

MARKS PUBLISHED FOR OPPOSITION

The following marks are published in compliance with section 12(a) of the Trademark Act of 1946. Applications for the registration of marks in more than one class have been filed as provided in section 30 of said act as amended by Public Law 772, 87th Congress, approved Oct. 9, 1962, 76 Stat. 769. Opposition under section 13 may be filed within thirty days of the date of this publication. See rules 2.101 to 2.105.

A separate fee of three hundred dollars (\$300.00) for opposing each mark in each class must accompany the opposition.

SECTION 1.— INTERNATIONAL CLASSIFICATION

The short titles associated below with the international class numbers are terms designed merely for quick identification and are not an official part of the international classification. The full names of international classes are given in section 6.1 of the trademark rules of practice.

The designation "U.S. Cl." appearing in this section refers to the U.S. class in effect prior to Sep. 1, 1973 rather than the international class which applies to applications filed on or after that date. For adoption of international classification see notice in the OFFICIAL GAZETTE of Jun. 26, 1973 (911 O.G. TM 210).

Application in more than one class

SN 76-701,896. PRIME FOCUS LIMITED, KHAR (W), MUMBAI 400054, INDIA, FILED 3-4-2010.



THE MARK CONSISTS OF A SHADED RECTANGLE. AT THE TOP OF THE RECTANGLE IS A DESIGN OF A MAN. UNDERNEATH THE DESIGN ARE THE WORDS "PRIME FOCUS", AND AT THE BOTTOM OF THE RECTANGLE, THE TERM "LET'S CREATE...".

CLASS 9—ELECTRICAL AND SCIENTIFIC APPARATUS

FOR PRE-RECORDED AUDIOCASSETTES AND VIDEOCASSETTES, COMPACT DISCS, ALL FEATURING FILMS AND MUSIC; LASER VIDEO DISCS AND DOWNLOADABLE VIDEO RECORDINGS ALL FEATURING FILMS AND MUSIC; MUSICAL SOUND RECORDINGS, VIDEO RECORDINGS AND AUDIO RECORDINGS FEATURING FILMS AND MUSIC; PHONOGRAPHIC RECORDINGS AND AUDIO DISCS ALL FEATURING FILMS AND MUSIC; PRE-RECORDED DVDS AND PRE-RECORDED DIGITAL AUDIO TAPES ALL IN THE FIELD OF FILMS AND MUSIC; SOFTWARE TO IMPROVE THE QUALITY OF FILMS, NAMELY, INTEGRATING TEXT, AUDIO, GRAPHICS, STILL IMAGES AND MOVING PICTURES; DIGITAL VIDEO AND AUDIO TAPE, CASSETTE AND DISC PLAYERS; JACKETS FOR VIDEO AND AUDIO CASSETTES, TAPES, AND DISCS (U.S. CLS. 21, 23, 26, 36 AND 38).

CLASS 35—ADVERTISING AND BUSINESS

FOR WEB-BASED MEDIA BUSINESS MANAGEMENT SERVICE DESIGNED TO HELP FILM STUDIOS, BROADCASTERS AND ADVERTISERS MORE EFFICIENTLY MANAGE THEIR CONTENT; PRODUCTION OF ADVERTISING MATTER (U.S. CLS. 100, 101 AND 102).

CLASS 41—EDUCATION AND ENTERTAINMENT

FOR MOTION PICTURE FILM AND MUSIC PRODUCTION; MOTION PICTURE FILM DISTRIBUTION; DISTRIBUTION OF MUSIC VIDEOS; DIGITAL IMAGING SERVICES FOR FILMS AND MEDIA PRODUCTS; MULTIMEDIA PUBLISHING SERVICES; EDITING OR RECORDING OF SOUNDS AND IMAGES; ENTERTAINMENT MEDIA PRODUCTION SERVICES FOR MOTION PICTURES, TELEVISION PROGRAMS AND INTERNET; FILM AND VIDEO PRODUCTION CONSULTING SERVICES; MEDIA PRODUCTION SERVICES, NAMELY, VIDEO AND FILM PRODUCTION; MULTIMEDIA ENTERTAINMENT SERVICES IN THE NATURE OF RECORDING, PRODUCTION AND POST-PRODUCTION SERVICES IN THE FIELDS OF MUSIC, VIDEO, AND FILMS, BROADCASTS, GAMING; PRODUCTION OF VIDEO AND CREATION OF VISUAL EFFECTS FOR OTHERS FOR USE IN DVDS, TELEVISION PROGRAMS AND ON WEB SITES; PRODUCTION OF VISUAL EFFECTS FOR VIDEOS, DVDS, TELEVISION AND FOR INTERNET WEB SITES; FILM EDITING; RENTAL OF AUDIO EQUIPMENT; RENTAL OF CAMERAS; SCRIPT WRITING SERVICES; RENTAL OF STAGE AND MOVIE EQUIPMENT, NAMELY, CAMERA EQUIPMENT, LIGHTING EQUIPMENT AND GRIP EQUIPMENT (U.S. CLS. 100, 101 AND 107).

CLASS 42—SCIENTIFIC AND COMPUTER SERVICES

FOR VISUAL DESIGN SERVICES IN THE NATURE OF DESIGNING VISUAL ELEMENTS FOR ON-LINE, BROADCAST, PRINT, AND ALL FORMATS OF MEDIA; WEBSITE DESIGN AND DEVELOPMENT FOR OTHERS; COMPUTER SOFTWARE DESIGN FOR THE FIELD OF MUSIC AND FILM; CONTENT CREATION FOR VIRTUAL WORLDS AND THREE DIMENSIONAL PLATFORMS; CREATING AN ON-LINE COMMUNITY FOR REGISTERED USERS TO PARTICIPATE IN COMPETITIONS, SHOWCASE THEIR SKILLS, GET FEEDBACK FROM THEIR PEERS, FORM VIRTUAL COMMUNITIES, ENGAGE IN SOCIAL NETWORKING AND IMPROVE THEIR TALENT; DIGITAL FORMATTING AND COMPRESSION OF MUSIC AND IMAGES, NAMELY, PRO-

CESSING OF DIGITAL MUSIC AND VIDEO IMAGES INTO DOWNLOADABLE PRODUCTS; INTERACTIVE HOSTING SERVICES WHICH ALLOW THE USER TO PUBLISH AND SHARE THEIR OWN CONTENT AND IMAGES ON-LINE; DESIGN AND CREATION OF COMPUTER-MODELED VERSIONS OF HUMAN BEINGS USING COMPUTER ANIMATION FOR USE IN MOVIES, TELEVISION, INTERNET, GAMES AND OTHER APPLICATIONS; DESIGN AND DEVELOPMENT OF MULTIMEDIA PRODUCTS; DESIGN OF VIRTUAL REALITY SOFTWARE; GRAPHIC ILLUSTRATION SERVICES FOR OTHERS; GRAPHIC DESIGN SERVICES; PRODUCT DEVELOPMENT IN THE FIELD OF FILM AND MUSIC; RESEARCH AND DEVELOPMENT AND CONSULTATION RELATED THERETO IN THE FIELD OF MUSIC AND MOVING IMAGES; SOFTWARE DEVELOPMENT AND PRODUCT DEVELOPMENT IN THE FIELD MUSIC AND MOVING IMAGES (U.S. CLS. 100 AND 101).

JANICE L. MCMORROW, EXAMINING ATTORNEY

SN 76-703,589. MIAMICA OF NEW YORK INC., A DIVISION OF SHALOM INTERNATIONAL, CORP., PERTH AMBOY, NJ. FILED 6-30-2010.

UPGRADE ME

THE MARK CONSISTS OF STANDARD CHARACTERS WITHOUT CLAIM TO ANY PARTICULAR FONT, STYLE, SIZE, OR COLOR.

CLASS 16—PAPER GOODS AND PRINTED MATTER

FOR PASSPORT CASES (U.S. CLS. 2, 5, 22, 23, 29, 37, 38 AND 50).

FIRST USE 0-0-2006; IN COMMERCE 0-0-2006.

CLASS 18—LEATHER GOODS

FOR LUGGAGE TAGS (U.S. CLS. 1, 2, 3, 22 AND 41).

FIRST USE 12-1-2006; IN COMMERCE 12-1-2006.

ADA HAN, EXAMINING ATTORNEY

SN 76-705,929. POWER-ONE, INC., CAMARILLO, CA. FILED 1-7-2011.

I-PWER

THE MARK CONSISTS OF STANDARD CHARACTERS WITHOUT CLAIM TO ANY PARTICULAR FONT, STYLE, SIZE, OR COLOR.

CLASS 9—ELECTRICAL AND SCIENTIFIC APPARATUS

FOR ELECTRONIC POWER SUPPLIES FOR SERVERS, ROUTERS, NETWORK SWITCHES, TELECOMMUNICATIONS EQUIPMENT, DATA COMMUNICATIONS EQUIPMENT, DISTRIBUTED POWER SYSTEMS, AND AUDIO/BROADCAST DEVICES; ELECTRONIC POWER CONVERTERS; ELECTRONIC POWER CONVERSION SYSTEMS, NAMELY, ELECTRONIC POWER CONVERTERS, POWER SUPPLIES, AND POINT-OF-LOAD VOLTAGE REGULATORS; ELECTRONIC POWER CONVERSION COMPONENTS, NAMELY, AC/DC AND DC/DC POWER CONVERTERS, FRONT ENDS IN THE NATURE OF HARDWARE COMPUTER INTERFACES FOR POWER SUPPLY AND POWER MANAGEMENT IN TELECOMMUNICATIONS, DATA COMMUNICATIONS, SERVERS, ROUTERS, SWITCHES, DISTRIBUTED POWER SYSTEMS, BOARD-MOUNTED POWER CONVERTERS, POINT OF LOAD VOLTAGE REGULATORS, RECTIFIERS AND INVERTERS; INTEGRATED CIRCUITS; COMPUTER SOFTWARE FOR MONITORING AND OPERATING ELECTRONIC POWER SUPPLIES AND POWER CONVERSION SYSTEMS; AND COMPUTER FIRMWARE FOR POWER CONVERSION SYSTEM DIAGNOSTICS AND CONFIGURATION, AND OPERATION, MANAGEMENT AND CONTROL OF ELECTRONIC CONVERSION COMPONENTS (U.S. CLS. 21, 23, 26, 36 AND 38).

CLASS 11—ENVIRONMENTAL CONTROL APPARATUS

FOR DC POWER PLANTS, NAMELY, ELECTRONIC POWER SHELVES AND SUBRACKS FOR ASSEMBLY OF DATA AND TELECOMMUNICATIONS POWER MANAGEMENT MODULES, RECTIFIERS, AND CONVERTERS (U.S. CLS. 13, 21, 23, 31 AND 34).

JANET LEE, EXAMINING ATTORNEY

SN 76-707,893. BUSINESS BROTHERS, INC., FORT LAUDERDALE, FL. FILED 6-8-2011.

SERVISTREE

THE MARK CONSISTS OF STANDARD CHARACTERS WITHOUT CLAIM TO ANY PARTICULAR FONT, STYLE, SIZE, OR COLOR.

CLASS 35—ADVERTISING AND BUSINESS

FOR BUSINESS ADVISORY SERVICES, CONSULTANCY AND INFORMATION; AND, ADVERTISING AND MARKETING SERVICES PROVIDED BY MEANS OF INDIRECT METHODS OF MARKETING COMMUNICATIONS, NAMELY, SOCIAL MEDIA, SEARCH ENGINE MARKETING, INQUIRY MARKETING, INTERNET MARKETING, MOBILE MARKETING, BLOGGING AND OTHER FORMS OF PASSIVE, SHARABLE, OR VIRAL COMMUNICATIONS CHANNELS (U.S. CLS. 100, 101 AND 102).

FIRST USE 11-19-2009; IN COMMERCE 11-19-2009.

CLASS 36—INSURANCE AND FINANCIAL

FOR UNDERWRITING INSURANCE SERVICES IN THE FIELD OF PRE-PAID LEGAL SERVICES; MERCHANT SERVICES, NAMELY, PAYMENT TRANSACTION PROCESSING SERVICES; PROVIDING ELECTRONIC PROCESSING OF ACH PAYMENTS VIA GLOBAL COMPUTER NETWORK; CASH ADVANCE SERVICES FOR BUSINESSES (U.S. CLS. 100, 101 AND 102).

FIRST USE 11-19-2009; IN COMMERCE 11-19-2009.

MATTHEW KLINE, EXAMINING ATTORNEY

SN 76-708,201. EWC CONTROLS, INC., ENGLISHTOWN, NJ.
FILED 7-1-2011.



OWNER OF U.S. REG. NO. 1,570,748.
THE MARK CONSISTS OF THE LETTERS "EWC" IN A
STYLIZED FONT WITH A CIRCLE CONTAINED WITHIN
THE CURVE OF THE LETTER "C".

**CLASS 9—ELECTRICAL AND SCIENTIFIC
APPARATUS**

FOR ELECTRONIC CONTROLS FOR ENVIRONMEN-
TAL HEATING AND COOLING APPARATUS (U.S. CLS.
21, 23, 26, 36 AND 38).

FIRST USE 1-1-1989; IN COMMERCE 1-1-1989.

**CLASS 11—ENVIRONMENTAL CONTROL AP-
PARATUS**

FOR ENVIRONMENTAL HEATING AND COOLING
APPARATUS, NAMELY, HEATING AND AIR CONDI-
TIONING ZONE DAMPERS (U.S. CLS. 13, 21, 23, 31 AND
34).

FIRST USE 1-1-1989; IN COMMERCE 1-1-1989.
TASHIA BUNCH, EXAMINING ATTORNEY

SN 76-708,610. CARTER GROUP LLC, THE, ADDISON, TX.
FILED 8-5-2011.



THE MARK CONSISTS OF STANDARD CHARACTERS
WITHOUT CLAIM TO ANY PARTICULAR FONT, STYLE,
SIZE, OR COLOR.

CLASS 35—ADVERTISING AND BUSINESS

FOR SOCIAL MEDIA STRATEGY AND MARKETING
CONSULTANCY SERVICES; CONSULTING RELATING
TO THE ADVERTISING AND MARKETING OF MOBILE
APPLICATIONS (U.S. CLS. 100, 101 AND 102).

FIRST USE 2-0-2011; IN COMMERCE 2-0-2011.

**CLASS 42—SCIENTIFIC AND COMPUTER
SERVICES**

FOR COMPUTER SOFTWARE DEVELOPMENT, PRO-
GRAMMING AND DESIGN FOR OTHERS IN THE
FIELD OF MOBILE APPLICATIONS AND CONSULTING
RELATING THERETO (U.S. CLS. 100 AND 101).

FIRST USE 2-0-2011; IN COMMERCE 2-0-2011.
ANDREW LEASER, EXAMINING ATTORNEY

SN 76-709,028. COMMONWEALTH OF PENNSYLVANIA,
DEPARTMENT OF AGRICULTURE, HARRISBURG, PA.
FILED 9-9-2011.



OWNER OF U.S. REG. NO. 2,839,853.
NO CLAIM IS MADE TO THE EXCLUSIVE RIGHT TO
USE "PA", APART FROM THE MARK AS SHOWN.

THE MARK CONSISTS OF A KEYSTONE OVER WHICH
A CHECK MARK IS IMPOSED, WITH THE CAPITAL
LETTERS "PA" IMMEDIATELY TO THE RIGHT OF THAT
CHECKED-KEYSTONE AND THE WORD "PREFERRED"
RUNNING IMMEDIATELY BENEATH THE CHECKED-
KEYSTONE AND "PA"

CLASS 29—MEATS AND PROCESSED FOODS

FOR MEAT, EGGS, MILK, PROCESSED FRUITS,
PROCESSED VEGETABLES (U.S. CL. 46).

FIRST USE 1-10-2004; IN COMMERCE 1-10-2004.

CLASS 30—STAPLE FOODS

FOR SALAD DRESSINGS (U.S. CL. 46).

FIRST USE 1-10-2004; IN COMMERCE 1-10-2004.

**CLASS 31—NATURAL AGRICULTURAL PRO-
DUCTS**

FOR RAW VEGETABLES, RAW FRUITS (U.S. CLS. 1
AND 46).

FIRST USE 1-10-2004; IN COMMERCE 1-10-2004.

CLASS 33—WINES AND SPIRITS

FOR WINES (U.S. CLS. 47 AND 49).

FIRST USE 1-10-2004; IN COMMERCE 1-10-2004.

ELLEN BURNS, EXAMINING ATTORNEY

SN 76-709,329. THE UNIVERSITY OF HOUSTON SYSTEM,
HOUSTON, TX. FILED 10-6-2011.



THE MARK CONSISTS OF STANDARD CHARACTERS
WITHOUT CLAIM TO ANY PARTICULAR FONT, STYLE,
SIZE, OR COLOR.

OWNER OF U.S. REG. NO. 2,359,695.

CLASS 16—PAPER GOODS AND PRINTED MATTER

FOR PRINT MATERIALS, NAMELY, MAGAZINES, PAMPHLETS AND BROCHURES IN THE FIELD OF RESEARCH, EDUCATION AND ATHLETICS, BUMPER STICKERS, PENS, PEN SETS, PENCILS, ERASERS, PENCIL TOPPERS, NAMELY, DECORATIVE PENCIL-TOPPERS, NAMELY, DECORATIVE PENCIL-TOP ORNAMENTS, LEAF BINDERS, BOOKMARKS, BOOK COVERS, PHOTOGRAPHIC ALBUMS, APPOINTMENT BOOKS, ART PHOTOGRAPHS, NAMELY, PHOTOGRAPHS THAT HAVE BEEN COMPUTER MANIPULATED AND ENHANCED TO CONTAIN GRAPHIC ELEMENTS, PHOTOS, ADDRESS BOOKS, PAPER BANNERS, PRINTED PAPER HANDHELD SIGNS, GIFT BAGS, PAPER SHOPPING BAGS, PLASTIC SHOPPING BAGS, MAGNETIC BOARDS, NOTEPADS, NOTE PAD HOLDERS, SCRAPBOOKS, CATALOGS IN THE FIELD OF ACADEMIC AND ATHLETIC COURSES AND ACADEMIC AND ATHLETIC GOODS, NEWSLETTERS IN THE FIELD OF RESEARCH, EDUCATION AND ATHLETICS, NOTEBOOKS, COMPOSITION BOOKS, PICTURE BOOKS, STATIONERY TYPE PORTFOLIOS, PAPER GIFT WRAP, CALENDARS, BLANK CARDS, PAPER GIFT CARDS, GREETING CARDS, BUSINESS CARDS, WRITING PAPER AND NOTE PAPER, POSTCARDS, DECALS, PAPER LABELS, BANK CHECKS, CHECKBOOK COVERS, RUBBER STAMPS, BOOKS IN THE FIELD OF RESEARCH, EDUCATION, AND ATHLETICS, BINDERS, LITHOGRAPHS AND PRINTS, PREPAID TELEPHONE CALLING CARDS, NOT MAGNETICALLY ENCODED, CREDIT CARDS WITHOUT MAGNETIC ENCODING, TRANSFERABLE TEMPORARY TATTOOS, STICKERS, POSTERS, PARTY GOODS, NAMELY, PAPER PARTY FAVORS, PAPER NAPKINS AND PAPER PARTY DECORATIONS, DESK ACCESSORIES, NAMELY, BASKETS, DESK PADS, FILE TRAYS, DESK ORGANIZERS, DESK PLANNERS, DESK-TOP REVOLVING ROTARY CARD FILES, DESK CALENDARS, PRINTED PAPER LABELS FOR BOTTLED WATER (U.S. CLS. 2, 5, 22, 23, 29, 37, 38 AND 50).

FIRST USE 11-6-1950; IN COMMERCE 11-6-1950.

CLASS 21—HOUSEWARES AND GLASS

FOR MUGS, CUPS, AND BOTTLE OPENERS (U.S. CLS. 2, 13, 23, 29, 30, 33, 40 AND 50).

FIRST USE 11-6-1950; IN COMMERCE 11-6-1950.

CLASS 25—CLOTHING

FOR CLOTHING, NAMELY, HATS, SHIRTS, PANTS, SWEAT PANTS, SWEAT SHIRTS, JACKETS, SOCKS, AND SWEATERS (U.S. CLS. 22 AND 39).

FIRST USE 11-6-1950; IN COMMERCE 11-6-1950.

CLASS 38—COMMUNICATION

FOR RADIO BROADCASTING AND RADIO PROGRAM BROADCASTING; COMMUNICATION SERVICES, NAMELY, TRANSMITTING STREAMED AUDIO MATERIAL THROUGH MEDIA OF CABLE AND SATELLITE SYSTEMS, THE INTERNET, AND PORTABLE AND WIRELESS DEVICES (U.S. CLS. 100, 101 AND 104).

FIRST USE 11-6-1950; IN COMMERCE 11-6-1950.

CLASS 41—EDUCATION AND ENTERTAINMENT

FOR EDUCATIONAL AND ENTERTAINMENT SERVICES, NAMELY, PROVIDING RADIO PROGRAMS IN THE FIELDS OF NEWS, WEATHER, BUSINESS, MUSIC, TRAFFIC, AND ACADEMICS (U.S. CLS. 100, 101 AND 107).

FIRST USE 11-6-1950; IN COMMERCE 11-6-1950.
LANA PHAM, EXAMINING ATTORNEY

SN 76-709,365. THE UNIVERSITY OF HOUSTON SYSTEM, HOUSTON, TX. FILED 10-12-2011.

KUHA

THE MARK CONSISTS OF STANDARD CHARACTERS WITHOUT CLAIM TO ANY PARTICULAR FONT, STYLE, SIZE, OR COLOR.

OWNER OF U.S. REG. NO. 2,359,695.

CLASS 16—PAPER GOODS AND PRINTED MATTER

FOR PRINT MATERIALS, NAMELY, MAGAZINES, PAMPHLETS AND BROCHURES IN THE FIELD OF RESEARCH, EDUCATION AND ATHLETICS, BUMPER STICKERS, PENS, PEN SETS, PENCILS, ERASERS, PENCIL TOPPERS, NAMELY, DECORATIVE PENCIL-TOP ORNAMENTS, LOOSE LEAF BINDERS, BOOKMARKS, BOOK COVERS, PHOTOGRAPHIC ALBUMS, APPOINTMENT BOOKS, ART PHOTOGRAPHS, NAMELY, PHOTOGRAPHS THAT HAVE BEEN COMPUTER MANIPULATED AND ENHANCED TO CONTAIN GRAPHIC ELEMENTS, PHOTOS, ADDRESS BOOKS, PAPER BANNERS, PRINTED PAPER HANDHELD SIGNS, GIFT BAGS, PAPER SHOPPING BAGS, PLASTIC SHOPPING BAGS, MAGNETIC BOARDS, NOTEPADS, NOTE PAD HOLDERS, SCRAPBOOKS, CATALOGS IN THE FIELD OF ACADEMIC AND ATHLETIC COURSES AND ACADEMIC AND ATHLETIC GOODS, NEWSLETTERS IN THE FIELD OF RESEARCH, EDUCATION AND ATHLETICS, NOTEBOOKS, COMPOSITION BOOKS, PICTURE BOOKS, STATIONERY TYPE PORTFOLIOS, PAPER GIFT WRAP, CALENDARS, BLANK CARDS, PAPER GIFT CARDS, GREETING CARDS, BUSINESS CARDS, WRITING PAPER AND NOTE PAPER, POSTCARDS, DECALS, PAPER LABELS, BANK CHECKS, CHECKBOOK COVERS, RUBBER STAMPS, BOOKS IN THE FIELD OF RESEARCH, EDUCATION, AND ATHLETICS, BINDERS, LITHOGRAPHS AND PRINTS, PREPAID TELEPHONE CALLING CARDS, NOT MAGNETICALLY ENCODED, CREDIT CARDS WITHOUT MAGNETIC ENCODING, TRANSFERABLE TEMPORARY TATTOOS, STICKERS, POSTERS, PARTY GOODS, NAMELY, PAPER PARTY FAVORS, PAPER NAPKINS AND PAPER PARTY DECORATIONS, DESK ACCESSORIES, NAMELY, BASKETS, DESK PADS, FILE TRAYS, DESK ORGANIZERS, DESK PLANNERS, DESK-TOP REVOLVING ROTARY CARD FILES, DESK CALENDARS, PRINTED PAPER LABELS FOR BOTTLED WATER (U.S. CLS. 2, 5, 22, 23, 29, 37, 38 AND 50).

FIRST USE 5-16-2011; IN COMMERCE 5-16-2011.

CLASS 25—CLOTHING

FOR CLOTHING, NAMELY, HATS, SHIRTS, PANTS, SWEAT PANTS, SWEAT SHIRTS, JACKETS, SOCKS, AND SWEATERS (U.S. CLS. 22 AND 39).

FIRST USE 5-16-2011; IN COMMERCE 5-16-2011.

CLASS 38—COMMUNICATION

FOR RADIO BROADCASTING AND RADIO PROGRAM BROADCASTING; COMMUNICATION SERVICES, NAMELY, TRANSMITTING STREAMED AUDIO MATERIAL THROUGH MEDIA OF CABLE AND SATELLITE SYSTEMS, THE INTERNET, AND PORTABLE AND WIRELESS DEVICES (U.S. CLS. 100, 101 AND 104).

FIRST USE 5-16-2011; IN COMMERCE 5-16-2011.

CLASS 41—EDUCATION AND ENTERTAINMENT

FOR EDUCATIONAL AND ENTERTAINMENT SERVICES, NAMELY, PROVIDING RADIO PROGRAMS IN THE FIELD OF NEWS, MUSIC, AND ACADEMIC DISCUSSIONS WITH FACULTY, MUSICIANS, SINGERS, AND MUSIC PROFESSIONALS (U.S. CLS. 100, 101 AND 107).

FIRST USE 5-16-2011; IN COMMERCE 5-16-2011.
LANA PHAM, EXAMINING ATTORNEY

SN 76-709,497. DONALDSON COMPANY, INC., MINNEAPOLIS, MN. FILED 10-24-2011.

TETRATEX CONTACT

THE MARK CONSISTS OF STANDARD CHARACTERS WITHOUT CLAIM TO ANY PARTICULAR FONT, STYLE, SIZE, OR COLOR.

OWNER OF U.S. REG. NOS. 1,278,010, 2,457,849 AND 3,779,963.

CLASS 11—ENVIRONMENTAL CONTROL APPARATUS

FOR FILTRATION MEDIA IN THE FORM OF A MEMBRANE OR MULTILAYER FABRIC FOR USE IN FILTERING GASES AND/OR LIQUIDS; MICROPOROUS MEMBRANES FOR THE VENTING, FILTRATION, STERILE FILTRATION AND PURIFICATION OF LIQUIDS AND GASES IN BREATHER VENT, GAS SENSOR, CHEMICAL VENTING, PROCESS CHEMICAL PURIFICATION, STERILE HYDROPHOBIC VENTING, AND ELECTRONIC AND COMPUTER AIR FILTER APPLICATIONS (U.S. CLS. 13, 21, 23, 31 AND 34).

CLASS 17—RUBBER GOODS

FOR MICROPOROUS SEMI-PERMEABLE POLYTETRAFLUOROETHYLENE (PTFE) MEMBRANES; PLASTIC IN THE FORM OF POROUS POLYTETRAFLUOROETHYLENE (PTFE) MEMBRANE SHEETS FOR USE IN MANUFACTURING, POLYMERIC FILTER MEDIA FOR DOMESTIC AND INDUSTRIAL FILTRATION (U.S. CLS. 1, 5, 12, 13, 35 AND 50).

ARETHA SOMERVILLE, EXAMINING ATTORNEY

SN 77-157,772. USFALCON, INC., MORRISVILLE, NC. FILED 4-16-2007.



THE MARK CONSISTS OF A BIRD IN FLIGHT WITH EXTENDED TALONS, WITH THE WORDING "USFALCON" BELOW THE BIRD.

CLASS 35—ADVERTISING AND BUSINESS

FOR TRANSPORTATION LOGISTICS SERVICES, NAMELY, ARRANGING THE TRANSPORTATION OF GOODS FOR OTHERS; BUSINESS ANALYTICAL SERVICES, NAMELY, BUSINESS APPRAISALS AND CONSULTATION (U.S. CLS. 100, 101 AND 102).

FIRST USE 3-17-2005; IN COMMERCE 3-17-2005.

CLASS 37—CONSTRUCTION AND REPAIR

FOR SECURITY EQUIPMENT INSTALLATION (U.S. CLS. 100, 103 AND 106).

FIRST USE 3-17-2005; IN COMMERCE 3-17-2005.

CLASS 42—SCIENTIFIC AND COMPUTER SERVICES

FOR INFORMATION TECHNOLOGY CONSULTATION; ENGINEERING (U.S. CLS. 100 AND 101).

FIRST USE 3-17-2005; IN COMMERCE 3-17-2005.

TEJBIR SINGH, EXAMINING ATTORNEY

SN 77-159,639. SOFAR S.P.A., TREZZANO ROSA (MI), ITALY, FILED 4-18-2007.



OWNER OF ERPN CMNTY TM OFC REG. NO. 005676101, DATED 1-8-2008, EXPIRES 1-8-2018.

THE MARK CONSISTS OF THE WORDS "ALF-X SOFAR" WITHIN A POLYGON, ALL ON A CONTRASTING BACKGROUND.

CLASS 9—ELECTRICAL AND SCIENTIFIC APPARATUS

FOR COMPUTER HARDWARE AND COMPUTER SOFTWARE ALL FOR USE WITH REMOTE TELE-SURGICAL PROCEDURES FOR TELE-OPERATING MANIPULATOR ARMS USING MOVE COMMANDS ISSUED BY HAPTIC MASTER ARMS GENERATING TACTILE FEEDBACK; COMPUTER HARDWARE AND COMPUTER SOFTWARE ALL FOR USE WITH REMOTE TELE-SURGICAL PROCEDURES FOR FILTERING AND GEOMETRICALLY TRANSFORMING MOVE COMMANDS ISSUED BY HAPTIC MASTER ARMS GENERATING TACTILE FEEDBACK AND SENSORS MOUNTED ON MANIPULATOR ARMS AND ON HAPTIC MASTER ARMS GENERATING TACTILE FEEDBACK; COMPUTER HARDWARE AND COMPUTER SOFTWARE ALL FOR USE WITH REMOTE TELE-SURGICAL PROCEDURES FOR DETECTING REAL TIME MOVEMENT OR PRESSURE BY SENSORS MOUNTED ON MANIPULATORS AND HAPTIC MASTER ARMS GENERATING TACTILE FEEDBACK; COMPUTER HARDWARE AND COMPUTER SOFTWARE ALL FOR USE WITH REMOTE TELE-SURGICAL PROCEDURES FOR SETTING-UP AND CALIBRATING SENSORS AND MANIPULATOR ARMS; COMPUTER HARDWARE AND COMPUTER SOFTWARE ALL FOR USE WITH REMOTE TELE-SURGICAL PROCEDURES FOR FACILITATING REAL-TIME COMMUNICATION BETWEEN COMPUTERS; COMPUTER HARDWARE AND COMPUTER SOFTWARE ALL FOR USE WITH REMOTE TELE-SURGICAL PROCEDURES FOR GRAPHICAL USER INTERFACES; COMPUTER HARDWARE AND COMPUTER SOFTWARE ALL FOR USE WITH REMOTE TELE-SURGICAL PROCEDURES FOR SIMULATING MANIPULATOR ARM BEHAVIOR AND SURGICAL INSTRUMENTS INTERACTION WITH TISSUES; COMPUTER HARDWARE AND COMPUTER SOFTWARE ALL FOR USE WITH REMOTE TELE-SURGICAL PROCEDURES FOR PROGRAMMING PROCEDURES TO CHANGE INSTRUMENTS, INSERTING INSTRUMENTS IN THE PATIENT BODY AND MANUALLY OPERATING MANIPULATING ARMS THROUGH SENSORY INFORMATION; COMPUTER HARDWARE AND COMPUTER SOFTWARE ALL FOR USE WITH REMOTE TELE-SURGICAL PROCEDURES FOR SIGNALING ABNORMAL FORCES APPLIED ON TISSUES, DETECTING ELECTRICAL AND MECHANICAL FAULTS AND SOFTWARE AND HARDWARE FAILURES, AND SIGNALING COLLISIONS BETWEEN MANIPULATOR ARMS AND BETWEEN THE ARM AND A HUMAN OPERATOR; COMPUTER HARDWARE AND COMPUTER SOFTWARE ALL FOR USE WITH REMOTE TELE-SURGICAL PROCEDURES FOR RECORDING IN REAL TIME DATA FROM SENSORS, MANIPULATOR ARMS AND HAPTIC MASTER ARMS GENERATING TACTILE FEEDBACK (U.S. CLS. 21, 23, 26, 36 AND 38).

CLASS 10—MEDICAL APPARATUS

FOR MEDICAL EQUIPMENT FOR USE IN REMOTE TELE-SURGICAL PROCEDURES, NAMELY, ROBOTIC MANIPULATOR ARMS MOUNTED ON A MOVABLE BASE, EQUIPPED WITH ACTUATORS FOR SURGICAL INSTRUMENTS AND WITH SENSORS FOR DETECTING PRESSURE OR FORCE, FOR DETECTING AND IDENTIFYING SURGICAL INSTRUMENTS, AND FOR DETECTING PERSONNEL SAFETY; MEDICAL EQUIPMENT FOR USE DURING SURGICAL PROCEDURES, NAMELY, HAPTIC MASTER ARMS WITH FOOT SWITCHES FOR GENERATING TACTILE FEEDBACK; MEDICAL ELECTRONIC EQUIPMENT AND SURGICAL INSTRUMENTS, NAMELY, SURGICAL DRAPES, TROCARS, MEDICAL BIOPSY BRUSHES, LAPAROSCOPES, ENDOSCOPES, ULTRASOUND PROBES, ELECTRO-CAUTERY TOOLS, CLIP APPLIERS AND CLIPS, TACK APPLIERS AND TACKS, CANNULAE, SCALPELS, SCALPEL BLADES, DISSECTORS, FORCEPS SCISSORS, CLAMPS, GRASPERS, STAPLERS, HEATERS AND CALIBRATORS, INSUFFLATORS, SUCTION PROBES, IRRIGATION PROBES, NEEDLE HOLDERS AND LIGATURE CARRIERS ALL FOR USE IN REMOTE SURGICAL PROCEDURES (U.S. CLS. 26, 39 AND 44).

CLASS 42—SCIENTIFIC AND COMPUTER SERVICES

FOR DESIGN AND DEVELOPMENT OF COMPUTER SOFTWARE USED IN THE MEDICAL AND SCIENTIFIC FIELDS AND USED WITH APPARATUS FOR REMOTE CONTROLLED SURGERY (U.S. CLS. 100 AND 101).
BERYL GARDNER, EXAMINING ATTORNEY

SN 77-183,297. JUMEIRAH INTERNATIONAL LLC, DUBAI, UNITED ARAB EMIR., FILED 5-17-2007.

TALISE

THE MARK CONSISTS OF STANDARD CHARACTERS WITHOUT CLAIM TO ANY PARTICULAR FONT, STYLE, SIZE, OR COLOR.

OWNER OF UNITED ARAB EMIR. REG. NO. 83641, DATED 8-23-2007, EXPIRES 11-7-2016.

OWNER OF UNITED ARAB EMIR. REG. NO. 91005, DATED 8-6-2008, EXPIRES 11-7-2016.

CLASS 3—COSMETICS AND CLEANING PREPARATIONS

FOR SOAPS; PERFUMES; AFTERSHAVE; AFTERSHAVE BALM; ESSENTIAL OILS; COSMETICS; PREPARATIONS FOR BATH AND SHOWER, NAMELY, BATH AND SHOWER GEL, BATH AND SHOWER FOAM, BATH SALTS; CREAMS AND LOTIONS FOR THE SKIN; ANTIPERSPIRANT SOAP; ANTIPERSPIRANTS; PERSONAL DEODORANTS; BEAUTY MASKS; BLEACHING PREPARATIONS FOR COSMETIC PURPOSES; BREATH FRESHENING SPRAYS; COSMETIC KITS COMPRISING OF EYE SHADOW, BLUSH, LIP GLOSS; COTTON STICKS AND COTTON WOOL FOR COSMETIC PURPOSES; COSMETIC CREAMS; DENTIFRICES; DEODORANT SOAP; DEPILATORIES; DISINFECTANT SOAP; COSMETIC DYES, NAMELY, HAIR DYES; EAU DE COLOGNE; EAU DE TOILETTE; ETHEREAL OILS IN THE NATURE OF ESSENTIAL OILS; EMERY PAPER FOR COSMETIC PURPOSES; EYEBROW COSMETICS; EYEBROW PENCILS; COSMETIC PREPARATIONS FOR EYELASHES, NAMELY, MASCARA; FALSE EYE LASHES; ADHESIVES FOR FIXING FALSE HAIR; FALSE NAILS; HAIR COLORANTS; HAIR LOTIONS; HAIR CARE PREPARATIONS; HAIRSPRAYS; HAIR WAVING PREPARATIONS, NAMELY, HAIR WAVING LOTION; INCENSE; SACHETS FOR PERFUMING LINEN; LIPSTICKS; LOTIONS FOR COSMETIC PURPOSES, NAMELY, HAND, BODY, FACE LOTION; TISSUES IMPREGNATED WITH COSMETIC LOTIONS; MAKE UP; MAKE UP POWDER; MAKE UP PREPARATIONS, NAMELY, FOUNDATIONS, EYE MAKE UP, BLUSH; MAKE UP REMOVING PREPARATIONS; MEDICATED SOAP; MOUSTACHE WAX; NON-MEDICATED MOUTH WASHES; NAIL CARE PREPARATIONS; NAIL POLISH; OILS FOR PERFUMES AND PERSONAL SCENTS; OILS FOR COSMETIC PURPOSES; HAIR STRAIGHTENING PREPARATIONS; COSMETIC PENCILS; PUMICE STONE FOR PERSONAL USE; SHAMPOOS; SHAVING PREPARATIONS; SHAVING SOAP; SHAVING GEL; SHAVING FOAM; SHAVING CREAM; COSMETIC PREPARATIONS FOR SKIN RENEWAL; SKIN WHITENING CREAMS; SUNSCREEN PREPARATIONS, NAMELY, SUNSCREEN CREAMS; COSMETIC SUN-TANNING PREPARATIONS; COTTON SWABS FOR COSMETIC PURPOSES; NON-MEDICATED TOILETRIES; MASSAGE OILS; FACIAL AND BODY MOISTURISERS; FACIAL AND BODY CLEANSERS; COSMETIC PREPARATIONS FOR TANNING THE SKIN; NAIL MANICURE AND PEDICURE PREPARATIONS, NAMELY, NAIL POLISH, NAIL POLISH REMOVER, NAIL CREAM; FACIAL AND BODY SCRUBS (U.S. CLS. 1, 4, 6, 50, 51 AND 52).

CLASS 44—MEDICAL, BEAUTY AND AGRICULTURAL SERVICES

FOR HYGIENIC AND BEAUTY CARE SERVICES, NAMELY, HAIR WASHING AND STYLING, PROVIDING SKIN AND FACIAL TREATMENTS, HAIR REMOVAL SERVICES; AROMATHERAPY SERVICES; PROVIDING TURKISH BATH FACILITIES; BEAUTY SALON SERVICES; HAIRDRESSING SALON SERVICES; MANICURING SERVICES; MASSAGE SERVICES; SAUNA SERVICES; HEALTH SPA SERVICES, NAMELY, COSMETIC BODY CARE SERVICES; HEALTH AND RELAXATION RESORT SERVICES, NAMELY, HEALTH SPA SERVICES FOR HEALTH AND WELLNESS OF THE BODY AND SPIRIT OFFERED AT A HEALTH RESORT; HEALTH AND MEDICAL INFORMATION SERVICES; FITNESS ASSESSMENT SERVICES FOR INDIVIDUALS TO HELP THEM MAKE HEALTH, WELLNESS AND NUTRITIONAL CHANGES IN THEIR DAILY LIVING TO IMPROVE HEALTH; DIETARY ADVICE; BEAUTY SERVICES, NAMELY, SKIN CARE SERVICES; COSMETIC TREATMENT SERVICES, NAMELY, MAKEUP APPLICATION SERVICES; PROVISION OF HUMAN TANNING SERVICES AND FACILITIES FOR COSMETIC PURPOSES; SALON SERVICES, NAMELY, PROVISION OF MANICURE AND PEDICURE SERVICES (U.S. CLS. 100 AND 101).

KATHERINE CHANG, EXAMINING ATTORNEY

SN 77-288,721. MOBERG DERMA AB, STOCKHOLM, SWEDEN, FILED 9-25-2007.

KAPROLAC

THE MARK CONSISTS OF STANDARD CHARACTERS WITHOUT CLAIM TO ANY PARTICULAR FONT, STYLE, SIZE, OR COLOR.

OWNER OF EUROPEAN UNION REG. NO. 004943213, DATED 4-17-2007, EXPIRES 3-7-2016.

SN 77-219,204. RICHTREE MARKET RESTAURANTS INC./RICHTREE RESTAURANTS DU MARCHE INC., ONTARIO, CANADA, FILED 6-29-2007.

FRESHNESS FOR ALL THE SENSES

THE MARK CONSISTS OF STANDARD CHARACTERS WITHOUT CLAIM TO ANY PARTICULAR FONT, STYLE, SIZE, OR COLOR.

PRIORITY CLAIMED UNDER SEC. 44(D) ON CANADA APPLICATION NO. 1,350,080, FILED 6-4-2007, REG. NO. TMA813,330, DATED 12-5-2011, EXPIRES 12-5-2026.

CLASS 35—ADVERTISING AND BUSINESS

FOR FRANCHISE SERVICES, NAMELY, OFFERING TECHNICAL AND BUSINESS MANAGEMENT ASSISTANCE IN THE ESTABLISHMENT AND OPERATION OF RESTAURANTS (U.S. CLS. 100, 101 AND 102).

CLASS 41—EDUCATION AND ENTERTAINMENT

FOR TRAINING SERVICES AND CONDUCTING SEMINARS IN THE FIELD OF RESTAURANTS (U.S. CLS. 100, 101 AND 107).

CLASS 43—HOTEL AND RESTAURANT SERVICES

FOR RESTAURANT, CATERING AND TAKE-OUT RESTAURANT SERVICES (U.S. CLS. 100 AND 101).
SKYE YOUNG, EXAMINING ATTORNEY

CLASS 3—COSMETICS AND CLEANING PREPARATIONS

FOR COSMETIC AND HYGIENIC PREPARATIONS, NAMELY, MAKE-UP, FACIAL CLEANSERS, SKIN CREAMS, SOAPS, DISINFECTANT SOAP, SHAMPOO, DEODORANTS FOR HYGIENIC PURPOSES, TOOTH-PASTES, FOOT-CLEANING PREPARATIONS, DEODORANTS FOR FEET, FOOT SPRAYS, EMOLLIENT CREAMS, COTTON STICKS FOR CLEANSING FOR COSMETIC PURPOSES, COTTON WOOL FOR COSMETIC PURPOSES, SHAVING CREAMS, AFTER-SHAVE PREPARATIONS, NAIL-CARE PREPARATIONS, NON-MEDICATED EMOLLIENT CREAMS FOR ANIMALS, SHAMPOO AND CONDITIONER FOR ANIMALS; PRE-MOISTENED WIPES FOR COSMETIC PURPOSES; ABSORBENT COTTON WOOL FOR COSMETIC PURPOSES (U.S. CLS. 1, 4, 6, 50, 51 AND 52).

CLASS 5—PHARMACEUTICALS

FOR PHARMACEUTICAL AND VETERINARY PREPARATIONS FOR THE TREATMENT OF DERMATOLOGICAL CONDITIONS AND/OR FUNGUS INFECTIONS; SANITARY PREPARATIONS FOR MEDICAL PURPOSES; COTTON STICKS FOR CLEANSING FOR MEDICAL PURPOSES; MEDICAL AND SURGICAL PLASTERS, DISINFECTANT PREPARATIONS, NAMELY, PHARMACEUTICAL PREPARATIONS WITH ANTIMICROBIAL, EMOLLIENT AND/OR CERATOLYTIC PROPERTIES, DERMATOLOGICAL PREPARATIONS, MEDICAL PREPARATIONS FOR THE TREATMENT OF DANDRUFF, DANDRUFF SHAMPOO, DANDRUFF CONDITIONER, MEDICAL PREPARATIONS FOR THE TREATMENT OF PSORIASIS, A TOPICAL ECZEMA, MEDICAL PREPARATIONS FOR THE TREATMENT AND PREVENTION OF ATHLETE'S FOOT, VAGINAL FUNGAL INFECTION AND OTHER FUNGAL INFECTIONS; MEDICATED PRE-MOISTENED WIPES, ABSORBENT COTTON WOOL FOR MEDICAL PURPOSES, BREAST PADS, TAMPONS, PLASTERS AND DRESSINGS PRE-TREATED WITH MEDICINES FOR THE TREATMENT AND PREVENTION OF FUNGAL INFECTIONS; MEDICATED BATH PREPARATIONS, DIAGNOSTIC PREPARATION FOR MEDICAL PURPOSES, MOUTHWASHES FOR MEDICAL PURPOSES, CHEWING GUM FOR MEDICAL PURPOSES, EMOLLIENT CREAMS FOR MEDICAL PURPOSES, SURGICAL COMPRESSES PRE-TREATED WITH PREPARATIONS FOR TREATING FUNGAL INFECTIONS; MEDICATED EMOLLIENT CREAMS FOR ANIMALS (U.S. CLS. 6, 18, 44, 46, 51 AND 52).

CLASS 10—MEDICAL APPARATUS

FOR MEDICAL APPARATUS AND INSTRUMENTS, NAMELY, MEDICAL DEVICES FOR THE APPLICATION OF MEDICINES FOR THE TREATMENT OR PREVENTION OF SKIN DISEASES AND INFECTIONS OF THE MUCOUS MEMBRANES, MEDICAL DEVICES FOR THE DOSING OF MEDICINES FOR THE TREATMENT OR PREVENTION OF SKIN DISEASES AND INFECTIONS OF THE MUCOUS MEMBRANES, SYRINGES FOR MEDICAL PURPOSES AND FOR INJECTIONS, IMPLANTS CONSISTING OF ARTIFICIAL MATERIALS, VAGINAL RINGS, VAGINAL SYRINGES, MEDICAL DEVICES FOR RETARDING THE EFFECT OF MEDICAL SUBSTANCES AND FOR DELIVERING MEDICINES TO THE BODY FOR THE TREATMENT OR PREVENTION OF SKIN DISEASES AND INFECTIONS OF THE MUCOUS MEMBRANES (U.S. CLS. 26, 39 AND 44).

PAUL E. FAHRENKOPF, EXAMINING ATTORNEY

SN 77-438,669. JUGGLE, LLC, BELLEVILLE, IL. FILED 4-3-2008.

JUGGLE

THE MARK CONSISTS OF STANDARD CHARACTERS WITHOUT CLAIM TO ANY PARTICULAR FONT, STYLE, SIZE, OR COLOR.

CLASS 35—ADVERTISING AND BUSINESS

FOR PROVIDING A WEB SITE WHERE USERS CAN POST RATINGS, REVIEWS AND RECOMMENDATIONS ON PRODUCTS AND SERVICES, AND PROVIDING CONSUMER PRODUCT INFORMATION VIA THE INTERNET (U.S. CLS. 100, 101 AND 102).

CLASS 38—COMMUNICATION

FOR PROVIDING ON-LINE ELECTRONIC BULLETIN BOARDS FOR TRANSMISSION OF MESSAGES AMONG USERS IN THE FIELD OF GENERAL INTEREST, AND CONCERNING RELATIONSHIPS TO PEOPLE, PLACES, THINGS AND ORGANIZATIONS; PROVIDING AN ON-LINE FORUM FOR TRANSMISSION OF MESSAGES AMONG COMPUTER USERS CONCERNING PEOPLE, PLACES, THINGS, EVENTS, EXPERIENCES, KNOWLEDGE, PRODUCTS, AND ADVERTISING; PROVIDING ON-LINE CHAT ROOMS AND ELECTRONIC BULLETIN BOARDS FOR TRANSMISSION OF MESSAGES AMONG USERS IN THE FIELD OF GENERAL INTEREST (U.S. CLS. 100, 101 AND 104).

CLASS 42—SCIENTIFIC AND COMPUTER SERVICES

FOR PROVIDING CUSTOMIZED ON-LINE WEB PAGES FEATURING USER-DEFINED INFORMATION, WHICH INCLUDES SEARCH ENGINES AND ON-LINE WEB LINKS TO OTHER WEB SITES; COMPUTER SERVICES IN THE NATURE OF CUSTOMIZED WEB PAGES FEATURING USER-DEFINED INFORMATION, PERSONAL PROFILES AND INFORMATION, INCLUDING INFORMATION ABOUT LIFE TIMELINES; COMPUTER SERVICES FOR AGGREGATING INFORMATION TO FACILITATE EASE OF ONLINE SEARCHING IN THE NATURE OF SEARCH ENGINE OPTIMIZATION; COMPUTER SERVICES IN THE NATURE OF CUSTOMIZED WEB PAGES FEATURING USER-DEFINED INFORMATION AND INFORMATION OBTAINED FROM OTHER WEBSITES INTO THEIR OWN WEBSITES; COMPUTER SERVICES, NAMELY, PROVIDING SEARCH ENGINES FOR OBTAINING DATA ON A GLOBAL COMPUTER NETWORK, PROVIDING A WEB SITE FEATURING TEMPORARY USE OF NON-DOWNLOADABLE SOFTWARE ALLOWING WEB SITE USERS TO SEARCH POSTED PROFILES OF OTHER INDIVIDUALS FOR INFORMATION PROVIDED IN SAID POSTING AND FOR ENABLING USERS TO SAVE, EDIT, ENHANCE AND REPUBLISH CONTENT FROM WEBSITE ONTO USERS PROFILE; COMPUTER SERVICE, NAMELY, ACTING AS AN APPLICATION SERVICE PROVIDER IN THE FIELD OF KNOWLEDGE MANAGEMENT TO HOST COMPUTER APPLICATION SOFTWARE FOR THE COLLECTION, EDITING, ORGANIZING, MODIFYING, BOOK MARKING, TRANSMISSION, STORAGE AND SHARING OF DATA AND INFORMATION; COMPUTER PROGRAMMING SERVICES FOR OTHERS THAT ENABLES CONSUMERS TO CREATE VERTICAL WEBSITES ON SEPARATE DOMAIN NAMES (U.S. CLS. 100 AND 101).

ANDREA K. NADELMAN, EXAMINING ATTORNEY

SN 77-446,422. LIDA KULUMCULUK SANAYI VE TICARET LTD., ISTANBUL, TURKEY, FILED 4-11-2008.

IDL INTERNATIONAL DIAMOND
LABORATORY

THE MARK CONSISTS OF STANDARD CHARACTERS WITHOUT CLAIM TO ANY PARTICULAR FONT, STYLE, SIZE, OR COLOR.

NO CLAIM IS MADE TO THE EXCLUSIVE RIGHT TO USE "INTERNATIONAL DIAMOND LABORATORY", APART FROM THE MARK AS SHOWN.

CLASS 14—JEWELRY

FOR PRECIOUS GEMSTONES; PRECIOUS STONES; DIAMONDS (U.S. CLS. 2, 27, 28 AND 50).

CLASS 16—PAPER GOODS AND PRINTED MATTER

FOR PAPER; PAPER AND CARDBOARD; CARDBOARD; PAPERBOARD; BOND PAPER; PUBLICATIONS, NAMELY, BROCHURES, BOOKLETS, AND TEACHING MATERIALS IN THE FIELD OF PRECIOUS GEMSTONES AND DIAMONDS; PUBLICATIONS, NAMELY, NEWSPAPERS, GENERAL FEATURE MAGAZINES AND NON-FICTION BOOKS IN THE FIELDS OF PRECIOUS GEMSTONES AND DIAMONDS; PRINTED CERTIFICATES; PRINTED CORRESPONDENCE COURSE MATERIALS IN THE FIELD OF PRECIOUS GEMSTONES AND DIAMONDS; PRINTED VISUALS IN THE NATURE OF PROMOTIONAL MATERIALS (U.S. CLS. 2, 5, 22, 23, 29, 37, 38 AND 50).

CLASS 35—ADVERTISING AND BUSINESS

FOR MEDIATION OF ADVERTISING; DISSEMINATION OF ADVERTISEMENTS; DISSEMINATION OF ADVERTISEMENTS AND OF ADVERTISING MATERIAL; DISSEMINATION OF ADVERTISING MATTER; ADVERTISING AND MARKETING; ADVERTISING, MARKETING AND PROMOTION SERVICES; DISSEMINATION OF ADVERTISING FOR OTHERS VIA THE INTERNET; INTERNET ADVERTISING SERVICES; PROVIDING INFORMATION ABOUT COMMERCIAL BUSINESS AND COMMERCIAL INFORMATION VIA THE GLOBAL COMPUTER NETWORK; MARKET STUDY AND ANALYSIS OF MARKET STUDIES; MARKET ANALYSIS; MARKET RESEARCH STUDIES; BUSINESS ORGANIZATIONAL CONSULTATION; DOCUMENT REPRODUCTION; COMPILATION AND SYSTEMATISATION OF INFORMATION IN DATABASES; PUBLICITY AND SALES PROMOTION RELATING TO GOODS AND SERVICES, OFFERED AND ORDERED BY TELECOMMUNICATION OR THE ELECTRONIC WAY (U.S. CLS. 100, 101 AND 102).

CLASS 41—EDUCATION AND ENTERTAINMENT

FOR EDUCATION SERVICES, NAMELY, PROVIDING TEACHING, CLASSES, SEMINARS, WORKSHOPS, INSTRUCTION AND COURSES IN THE FIELDS OF PRECIOUS GEMSTONES AND DIAMONDS; LIBRARIES; PUBLISHING OF BOOKS, MAGAZINES; PUBLISHING OF ELECTRONIC PUBLICATIONS; NEWSPAPER PUBLISHING; PUBLICATION AND EDITING OF PRINTED MATTER; WRITTEN TEXT EDITING (U.S. CLS. 100, 101 AND 107).

CLASS 42—SCIENTIFIC AND COMPUTER SERVICES

FOR TESTING, ANALYSIS AND EVALUATION OF THE GOODS AND SERVICES OF OTHERS FOR THE PURPOSE OF CERTIFICATION; QUALITY CONTROL FOR OTHERS; APPLICATION SERVICE PROVIDER (ASP) FEATURING SOFTWARE FOR USE IN THE FIELD OF DATABASES CONTAINING INFORMATION ABOUT PRECIOUS GEMSTONES AND DIAMONDS; PROVIDING SPECIFIC INFORMATION AS REQUESTED BY CUSTOMERS VIA THE INTERNET; PROVIDING QUALITY ASSURANCE SERVICES IN THE FIELD OF PRECIOUS GEMSTONES AND DIAMONDS (U.S. CLS. 100 AND 101).

JASON TURNER, EXAMINING ATTORNEY

SN 77-523,056. MUSIC IS MY BUSINESS, LLC, ATLANTA, GA. FILED 7-15-2008.

Music Is My Business

THE MARK CONSISTS OF STANDARD CHARACTERS WITHOUT CLAIM TO ANY PARTICULAR FONT, STYLE, SIZE, OR COLOR.

NO CLAIM IS MADE TO THE EXCLUSIVE RIGHT TO USE "MUSIC", APART FROM THE MARK AS SHOWN.

CLASS 9—ELECTRICAL AND SCIENTIFIC APPARATUS

FOR COMPUTER SOFTWARE FEATURING MUSICAL SOUND RECORDINGS AND MUSICAL VIDEO RECORDINGS; DIGITAL MEDIA, NAMELY, PRE-RECORDED VIDEO CASSETTES, DIGITAL VIDEO DISCS, DIGITAL VERSATILE DISCS, DOWNLOADABLE AUDIO AND VIDEO RECORDINGS, DVDS, AND HIGH DEFINITION DIGITAL DISKS FEATURING MUSIC; DOWNLOADABLE MP3 FILES, MP3 RECORDINGS, ON-LINE DISCUSSION BOARDS, WEBCASTS AND PODCASTS FEATURING MUSIC, AUDIO BOOKS AND NEWS BROADCASTS; DOWNLOADABLE MUSICAL SOUND RECORDINGS; DOWNLOADABLE VIDEO RECORDINGS FEATURING MUSIC; MUSICAL SOUND RECORDINGS; MUSICAL VIDEO RECORDINGS; PRE-RECORDED CDS FEATURING MUSIC; PRE-RECORDED CDS, VIDEO TAPES, LASER DISKS AND DVDS FEATURING MUSIC; PRE-RECORDED DIGITAL MEDIA FEATURING MUSIC; PRE-RECORDED ELECTRONIC MEDIA MUSIC; VIDEOTAPES AND VIDEO DISKS RECORDED WITH ANIMATION; VISUAL RECORDINGS AND AUDIOVISUAL RECORDINGS FEATURING MUSIC AND ANIMATION (U.S. CLS. 21, 23, 26, 36 AND 38).

FIRST USE 3-15-2005; IN COMMERCE 5-2-2005.

CLASS 25—CLOTHING

FOR ATHLETIC APPAREL, NAMELY, SHIRTS, PANTS, JACKETS, FOOTWEAR, HATS AND CAPS, ATHLETIC UNIFORMS; DENIM JACKETS; FOOTWEAR; FOOTWEAR FOR MEN AND WOMEN; HAT BANDS; HATS; HOODED SWEAT SHIRTS; JACKETS AND SOCKS; LEATHER JACKETS; LONG-SLEEVED SHIRTS; POLO SHIRTS; RAIN JACKETS; REVERSIBLE JACKETS; SHIRTS; SHORT-SLEEVED OR LONG-SLEEVED T-SHIRTS; SPORT SHIRTS; SPORTS JACKETS; SWEAT JACKETS; SWEAT SHIRTS; T-SHIRTS; TOBOGGAN HATS, PANTS AND CAPS; WEARABLE GARMENTS AND CLOTHING, NAMELY, SHIRTS; WRISTBANDS (U.S. CLS. 22 AND 39).

FIRST USE 3-15-2005; IN COMMERCE 5-2-2005.

CLASS 41—EDUCATION AND ENTERTAINMENT

FOR ARRANGING AND CONDUCTING NIGHTCLUB ENTERTAINMENT EVENTS; EDUCATIONAL AND ENTERTAINMENT SERVICES, NAMELY, PROVIDING MOTIVATIONAL AND EDUCATIONAL SPEAKERS; ENTERTAINMENT AND EDUCATIONAL SERVICES, NAMELY, PROVIDING ADVICE AND INFORMATION FOR MUSIC, VIDEO AND FILM CONCEPT AND SCRIPT DEVELOPMENT; ENTERTAINMENT IN THE NATURE OF LIVE PERFORMANCES BY RECORDING ARTISTS; ENTERTAINMENT, NAMELY, IN THE FIELD OF MOVIES, CABLE TELEVISION OR VIA THE WORLD WIDE WEB; ENTERTAINMENT IN THE NATURE OF THEATER PRODUCTIONS; ENTERTAINMENT IN THE NATURE OF VISUAL AND AUDIO PERFORMANCES, AND MUSICAL, VARIETY, NEWS AND COMEDY SHOWS; ENTERTAINMENT IN THE NATURE OF VISUAL AND AUDIO PERFORMANCES, NAMELY, MUSICAL BAND, ROCK GROUP, GYMNASIAC, DANCE, AND BALLET PERFORMANCES; ENTERTAINMENT IN THE NATURE OF LIVE PERFORMANCES BY MUSICAL ARTISTS AND MUSICAL BANDS; ENTERTAINMENT INFORMATION; ENTERTAINMENT SERVICES IN THE NATURE OF LIVE MUSICAL PERFORMANCES; ENTERTAINMENT SERVICES, NAMELY, PROVIDING A WEB SITE FEATURING PHOTOGRAPHIC, AUDIO, VIDEO AND PROSE PRESENTATIONS FEATURING MUSICAL CONTENT; ENTERTAINMENT SERVICES, NAMELY, CONDUCTING PARTIES; ENTERTAINMENT SERVICES, NAMELY, MULTIMEDIA PRODUCTION SERVICES; ENTERTAINMENT SERVICES, NAMELY, NON-DOWNLOADABLE RINGTONES, PRE-RECORDED MUSIC, VIDEO AND GRAPHICS PRESENTED TO MOBILE COMMUNICATIONS DEVICES VIA A GLOBAL COMPUTER NETWORK AND WIRELESS NETWORKS; PROVISION OF NON-DOWNLOADABLE FILMS AND MOVIES VIA A VIDEO-ON-DEMAND SERVICE; ENTERTAINMENT SERVICES, NAMELY, PROVIDING A WEB SITE FEATURING MUSICAL PERFORMANCES, MUSICAL VIDEOS, RELATED FILM CLIPS, PHOTOGRAPHS,

AND OTHER MULTIMEDIA MATERIALS; ENTERTAINMENT SERVICES, NAMELY, PROVIDING ON-LINE REVIEWS OF MUSIC AND TV AND FILM CONTENT; ENTERTAINMENT SERVICES, NAMELY, PROVIDING PRERECORDED MUSIC, INFORMATION IN THE FIELD OF MUSIC, AND COMMENTARY AND ARTICLES ABOUT MUSIC, ALL ON-LINE VIA A GLOBAL COMPUTER NETWORK; ENTERTAINMENT, NAMELY, LIVE MUSIC CONCERTS; ENTERTAINMENT, NAMELY, LIVE PERFORMANCES BY MUSICAL BANDS; ENTERTAINMENT, NAMELY, LIVE PERFORMANCES BY ROCK GROUPS; ENTERTAINMENT, NAMELY, PRODUCTION OF MUSIC AND FILM AND TV SHOWS AND ONLINE MUSIC, FILM AND VIDEO CONTENT AND TV PROGRAMS; FILM AND VIDEO FILM PRODUCTION; FILM AND VIDEO PRODUCTION; FILM DISTRIBUTION; FILM EDITING; FILM PRODUCTION; MEDIA PRODUCTION SERVICES, NAMELY, VIDEO AND FILM PRODUCTION; MOBILE MEDIA AND ENTERTAINMENT SERVICES IN THE NATURE OF CONTENT PREPARATION; MOBILE MEDIA AND ENTERTAINMENT SERVICES IN THE NATURE OF CONTENT PREPARATION, POST-PRODUCTION; MOTION PICTURE FILM PRODUCTION; MOTION PICTURE FILMS AND FILMS FOR TELEVISION FEATURING CHILDREN'S ENTERTAINMENT; MULTIMEDIA ENTERTAINMENT SERVICES IN THE NATURE OF RECORDING, PRODUCTION AND POST-PRODUCTION SERVICES IN THE FIELDS OF MUSIC, VIDEO, AND FILMS; MUSIC SELECTION SERVICES FOR USE IN TELEVISION, FILM, RADIO AND VIDEO GAMES; POST-PRODUCTION EDITING SERVICES IN THE FIELD OF MUSIC, VIDEOS AND FILMS; PRODUCTION OF FILMS; PROVIDING INFORMATION AND ARTICLES IN THE FIELD OF FILM, FILMMAKING, AND ENTERTAINMENT VIA A GLOBAL COMPUTER NETWORK; PROVIDING INFORMATION IN THE FIELD OF ENTERTAINMENT, FEATURING ANIMATION RENDERED BY MEANS OF A GLOBAL COMPUTER NETWORK; PROVIDING INFORMATION, NEWS AND COMMENTARY IN THE FIELD OF ENTERTAINMENT (U.S. CLS. 100, 101 AND 107).

FIRST USE 3-15-2005; IN COMMERCE 5-2-2005.

WILLIAM BRECKENFELD, EXAMINING ATTORNEY

SN 77-556,253. SHIRE PHARMACEUTICALS LIMITED, HAMPSHIRE, UNITED KINGDOM, FILED 8-26-2008.

BRAVE

THE MARK CONSISTS OF STANDARD CHARACTERS WITHOUT CLAIM TO ANY PARTICULAR FONT, STYLE, SIZE, OR COLOR.

OWNER OF GREAT BRITAIN REG. NO. 2496085, DATED 8-26-2008, EXPIRES 8-26-2018.

CLASS 9—ELECTRICAL AND SCIENTIFIC APPARATUS

FOR DOWNLOADABLE PUBLICATIONS, NAMELY, JOURNALS, NEWSLETTERS, BROCHURES, BOOKS AND PAMPHLETS RELATING TO PHARMACEUTICALS FOR THE TREATMENT OF HUMAN ATTENTION DEFICIT AND HYPERACTIVITY DISORDER, GASTROINTESTINAL DISEASES, OSTEOPOROSIS, AND RENAL DISEASES, AND FOR HUMAN GENETIC THERAPY (U.S. CLS. 21, 23, 26, 36 AND 38).

CLASS 16—PAPER GOODS AND PRINTED MATTER

FOR PRINTED MATTER, NAMELY, JOURNALS, NEWSLETTERS, BROCHURES, BOOKS AND PAMPHLETS, ALL IN THE PHARMACEUTICAL, MEDICAL AND HEALTHCARE FIELDS OF HUMAN ATTENTION DEFICIT AND HYPERACTIVITY DISORDER, GASTROINTESTINAL DISEASES, OSTEOPOROSIS, RENAL DISEASES, AND HUMAN GENETIC THERAPY; PRINTED INSTRUCTIONAL AND TEACHING MATERIAL IN THE PHARMACEUTICAL, MEDICAL AND HEALTHCARE FIELDS OF HUMAN ATTENTION DEFICIT AND HYPERACTIVITY DISORDER, GASTROINTESTINAL DISEASES, OSTEOPOROSIS, RENAL DISEASES, AND HUMAN GENETIC THERAPY (U.S. CLS. 2, 5, 22, 23, 29, 37, 38 AND 50).

CLASS 41—EDUCATION AND ENTERTAINMENT

FOR EDUCATIONAL SERVICES, NAMELY, CLASSES, SEMINARS, CONFERENCES AND LECTURES RELATING TO MEDICAL GOODS AND SERVICES AND HEALTHCARE GOODS AND SERVICES IN THE FIELDS OF HUMAN ATTENTION DEFICIT AND HYPERACTIVITY DISORDER, GASTROINTESTINAL DISEASES, OSTEOPOROSIS, RENAL DISEASES, AND HUMAN GENETIC THERAPY; TRAINING SERVICES RELATING TO MEDICAL GOODS AND SERVICES AND HEALTHCARE GOODS AND SERVICES IN THE FIELDS OF HUMAN ATTENTION DEFICIT AND HYPERACTIVITY DISORDER, GASTROINTESTINAL DISEASES, OSTEOPOROSIS, RENAL DISEASES, AND HUMAN GENETIC THERAPY; ARRANGING AND CONDUCTING EDUCATIONAL CONFERENCES AND SEMINARS RELATING TO MEDICAL GOODS AND SERVICES AND HEALTHCARE GOODS AND SERVICES IN THE FIELDS OF HUMAN ATTENTION DEFICIT AND HYPERACTIVITY DISORDER, GASTROINTESTINAL DISEASES, OSTEOPOROSIS, RENAL DISEASES, AND HUMAN GENETIC THERAPY (U.S. CLS. 100, 101 AND 107).

CLASS 42—SCIENTIFIC AND COMPUTER SERVICES

FOR PROVIDING MEDICAL RESEARCH INFORMATION AND SCIENTIFIC RESEARCH INFORMATION ABOUT PHARMACEUTICALS AND CLINICAL TRIALS IN THE FIELDS OF HUMAN ATTENTION DEFICIT AND HYPERACTIVITY DISORDER, GASTROINTESTINAL DISEASES, OSTEOPOROSIS, RENAL DISEASES, AND HUMAN GENETIC THERAPY; MEDICAL AND SCIENTIFIC RESEARCH, NAMELY, CONDUCTING CLINICAL TRIALS IN THE AFORESAID FIELDS; INFORMATION, CONSULTANCY AND ADVISORY SERVICES RELATING TO ALL THE AFORESAID SERVICES (U.S. CLS. 100 AND 101).

RON FAIRBANKS, EXAMINING ATTORNEY

SN 77-588,554. TBF GROUP, LLC, JERSEY CITY, NJ. FILED 10-8-2008.

frugal is the new black

THE MARK CONSISTS OF STANDARD CHARACTERS WITHOUT CLAIM TO ANY PARTICULAR FONT, STYLE, SIZE, OR COLOR.

CLASS 16—PAPER GOODS AND PRINTED MATTER

FOR PUBLICATIONS, NAMELY, BOOKS, ARTICLES, NEWSLETTERS, BROCHURES, AND PRINTED EDUCATIONAL MATERIALS IN THE FIELDS OF FASHION, RETAIL, TRENDS, CURRENT EVENTS, GENERAL FINANCIAL MATTERS, BUDGET MANAGEMENT, EXPENSE SAVING, AND COST INFORMATION ON THE GOODS AND SERVICES OF OTHERS (U.S. CLS. 2, 5, 22, 23, 29, 37, 38 AND 50).

CLASS 41—EDUCATION AND ENTERTAINMENT

FOR ONLINE PUBLICATIONS, NAMELY, ONLINE NEWSLETTERS, BLOGS, AND PROVIDING AN ELECTRONIC LIBRARY OF, AND LINKS TO, INFORMATION AND EDUCATIONAL MATERIALS IN THE FIELDS OF FASHION, RETAIL, TRENDS, CURRENT EVENTS, GENERAL FINANCIAL MATTERS, BUDGET MANAGEMENT, EXPENSE SAVING, AND COST INFORMATION ON THE GOODS AND SERVICES OF OTHERS; PROVIDING A WEBSITE FEATURING INFORMATION ON CURRENT EVENTS (U.S. CLS. 100, 101 AND 107).

CLASS 45—PERSONAL AND LEGAL SERVICES

FOR PROVIDING A WEBSITE FEATURING INFORMATION ON FASHION, AND FASHION TRENDS (U.S. CLS. 100 AND 101).

GIANCARLO CASTRO, EXAMINING ATTORNEY

CLASS 37—CONSTRUCTION AND REPAIR

FOR INSTALLATION, REPAIR AND MAINTENANCE OF COMPONENTS OF ENERGY SYSTEMS, NAMELY, SOLAR ENERGY SYSTEMS, WIND ENERGY SYSTEMS, BIOMASS ENERGY SYSTEMS, BIOGAS ENERGY SYSTEMS AND WAVE ENERGY SYSTEMS, NAMELY, TURBINES, GENERATORS, ENERGY STORAGE DEVICES, CONTROL INSTRUMENTATION, METERING INSTRUMENTATION AS WELL AS PARTS; ERECTION AND CONSTRUCTION OF SOLAR ENERGY PLANTS, WIND ENERGY PLANTS, BIOMASS ENERGY PLANTS, BIOGAS ENERGY PLANTS AND WAVE ENERGY PLANTS; CONSULTING IN THE FIELDS OF INSTALLATION, REPAIR AND MAINTENANCE OF ENERGY, NAMELY, SOLAR ENERGY SYSTEMS, WIND ENERGY SYSTEMS, BIOMASS ENERGY SYSTEMS, BIOGAS ENERGY SYSTEMS AND WAVE ENERGY SYSTEMS, NAMELY, TURBINES, GENERATORS, ENERGY STORAGE DEVICES, CONTROL INSTRUMENTATION, METERING INSTRUMENTATION AS WELL AS PARTS (U.S. CLS. 100, 103 AND 106).

CLASS 40—MATERIAL TREATMENT

FOR CONSULTING IN THE FIELD OF ENERGY GENERATED BY SOLAR ENERGY SYSTEMS, WIND ENERGY SYSTEMS, BIOMASS ENERGY SYSTEMS, BIOGAS ENERGY SYSTEMS AND WAVE ENERGY SYSTEMS COMPRISED OF TURBINES, GENERATORS, ENERGY STORAGE DEVICES, CONTROL INSTRUMENTATION, METERING INSTRUMENTATION AS WELL AS PARTS; CONSULTING IN THE FIELD OF ENERGY GENERATED BY COMPONENTS OF ENERGY SYSTEMS AND SOLAR ENERGY SYSTEMS, WIND ENERGY SYSTEMS, BIOMASS ENERGY SYSTEMS, BIOGAS ENERGY SYSTEMS AND WAVE ENERGY SYSTEMS COMPRISED OF TURBINES, GENERATORS, ENERGY STORAGE DEVICES, CONTROL INSTRUMENTATION, METERING INSTRUMENTATION AS WELL AS PARTS; CONSULTING IN THE FIELDS OF ERECTION AND CONSTRUCTION OF TURBINES, GENERATORS, ENERGY STORAGE DEVICES, CONTROL INSTRUMENTATION, METERING INSTRUMENTATION AS WELL AS PARTS (U.S. CLS. 100, 103 AND 106).

SN 77-604,634. ENXCO, INC., SAN DIEGO, CA. FILED 10-30-2008.



OWNER OF U.S. REG. NO. 2,643,299.

NO CLAIM IS MADE TO THE EXCLUSIVE RIGHT TO USE "COMPANY", APART FROM THE MARK AS SHOWN.

THE MARK CONSISTS OF THE WORD "ENXCO" IN LARGE BLOCK LETTERS, THE LETTER "X" IS PRESENTED LARGER THAN THE REST OF THE WORDING AND IS DISPLAYED WITH FOUR CURVED LINES ABOVE AND BELOW THE LETTER "X." THE WORDING "AN EDF EN COMPANY" IS PRESENTED BELOW "XCO" IN "ENXCO".

CLASS 42—SCIENTIFIC AND COMPUTER SERVICES

FOR DESIGN AND DEVELOPMENT OF COMPONENTS OF ENERGY SYSTEMS, NAMELY, DESIGN AND DEVELOPMENT OF SOLAR ENERGY SYSTEMS, WIND ENERGY SYSTEMS, BIOMASS ENERGY SYSTEMS, BIOGAS ENERGY SYSTEMS AND WAVE ENERGY SYSTEMS COMPRISED OF TURBINES, GENERATORS, ENERGY STORAGE DEVICES, CONTROL INSTRUMENTATION, METERING INSTRUMENTATION AS WELL AS PARTS AND ACCESSORIES; CONSULTING IN THE FIELDS OF DESIGN AND DEVELOPMENT OF ENERGY SYSTEMS, SOLAR ENERGY SYSTEMS, WIND ENERGY SYSTEMS, BIOMASS ENERGY SYSTEMS, BIOGAS ENERGY SYSTEMS AND WAVE ENERGY SYSTEMS COMPRISED OF TURBINES, GENERATORS, ENERGY STORAGE DEVICES, CONTROL INSTRUMENTATION, METERING INSTRUMENTATION AND PARTS AND ACCESSORIES THERETO (U.S. CLS. 100 AND 101).

RENEE SERVANCE, EXAMINING ATTORNEY

SN 77-616,078. INTERPRO MANUFACTURING LIMITED, KOWLOON BAY, HONG KONG, FILED 11-17-2008.

SN 77-709,851. AVEOS FLEET PERFORMANCE INC., SAINT-LAURENT, QUEBEC, CANADA, FILED 4-8-2009.

SIMPLY PET

PARTNERS IN PERFORMANCE

THE MARK CONSISTS OF STANDARD CHARACTERS WITHOUT CLAIM TO ANY PARTICULAR FONT, STYLE, SIZE, OR COLOR.

NO CLAIM IS MADE TO THE EXCLUSIVE RIGHT TO USE "PET", APART FROM THE MARK AS SHOWN.

CLASS 19—NON-METALLIC BUILDING MATERIALS

FOR PRE-FABRICATED DOG HOUSES (U.S. CLS. 1, 12, 33 AND 50).

CLASS 21—HOUSEWARES AND GLASS

FOR PET FOOD STORAGE CONTAINERS, WATER DISPENSERS FOR PETS, AND PET FEEDING DISHES (U.S. CLS. 2, 13, 23, 29, 30, 33, 40 AND 50).

SHAUNIA CARLYLE, EXAMINING ATTORNEY

THE MARK CONSISTS OF STANDARD CHARACTERS WITHOUT CLAIM TO ANY PARTICULAR FONT, STYLE, SIZE, OR COLOR.

PRIORITY CLAIMED UNDER SEC. 44(D) ON CANADA APPLICATION NO. 1413998, FILED 10-9-2008, REG. NO. TMA810,258, DATED 10-26-2011, EXPIRES 10-26-2026.

CLASS 16—PAPER GOODS AND PRINTED MATTER

FOR PRINTED TRAINING MATERIALS RELATING TO AIRCRAFT MAINTENANCE, REPAIR AND OVERHAUL (U.S. CLS. 2, 5, 22, 23, 29, 37, 38 AND 50).

CLASS 35—ADVERTISING AND BUSINESS

FOR BUSINESS MANAGEMENT SERVICES, NAMELY, ENGINE FLEET MANAGEMENT; SUPPLY CHAIN MANAGEMENT SERVICES (U.S. CLS. 100, 101 AND 102).

CLASS 37—CONSTRUCTION AND REPAIR

FOR AIRCRAFT AND AIRFRAME MAINTENANCE, REPAIR AND OVERHAUL SERVICES; AIRCRAFT CABIN CONVERSIONS AND MODIFICATIONS; AIRCRAFT ENGINE AND ENGINE PARTS AND COMPONENTS MAINTENANCE, REPAIR AND OVERHAUL SERVICES (U.S. CLS. 100, 103 AND 106).

CLASS 39—TRANSPORTATION AND STORAGE

FOR LEASING OF AIRCRAFT ENGINES AND PARTS (U.S. CLS. 100 AND 105).

CLASS 41—EDUCATION AND ENTERTAINMENT

FOR AIRCRAFT SAFETY AND MAINTENANCE TRAINING; TRAINING FOR MAINTENANCE, REPAIR AND OVERHAUL OF AIRCRAFT, AIRFRAMES, ENGINES AND ENGINE PARTS AND COMPONENTS (U.S. CLS. 100, 101 AND 107).

CLASS 42—SCIENTIFIC AND COMPUTER SERVICES

FOR TECHNICAL WRITING FOR OTHERS, NAMELY, CREATING CUSTOMIZED TRAINING MATERIALS RELATING TO AIRCRAFT MAINTENANCE, REPAIR AND OVERHAUL; AIRCRAFT WEIGHING SERVICES (U.S. CLS. 100 AND 101).

DANNEAN HETZEL, EXAMINING ATTORNEY

SN 77-630,163. DAVITA INC., DENVER, CO. FILED 12-10-2008.

EMPOWER

THE MARK CONSISTS OF STANDARD CHARACTERS WITHOUT CLAIM TO ANY PARTICULAR FONT, STYLE, SIZE, OR COLOR.

CLASS 14—JEWELRY

FOR ORNAMENTAL PINS (U.S. CLS. 2, 27, 28 AND 50).

CLASS 16—PAPER GOODS AND PRINTED MATTER

FOR PUBLICATIONS, NAMELY, PAMPHLETS AND BROCHURES IN THE FIELD OF CHRONIC KIDNEY DISEASE AND DIALYSIS (U.S. CLS. 2, 5, 22, 23, 29, 37, 38 AND 50).

CLASS 25—CLOTHING

FOR CLOTHING, NAMELY, SHIRTS AND HATS (U.S. CLS. 22 AND 39).

MEGHAN REINHART, EXAMINING ATTORNEY

SN 77-731,672. MUNICIPIO DE GUANAJUATO, GUANAJUATO, GUANAJUATO, MEXICO, FILED 5-7-2009.



PRIORITY CLAIMED UNDER SEC. 44(D) ON MEXICO APPLICATION NO. 980062, FILED 12-15-2008, REG. NO. 1085883, DATED 2-19-2009, EXPIRES 12-15-2018.

PRIORITY CLAIMED UNDER SEC. 44(D) ON MEXICO APPLICATION NO. 980063, FILED 12-15-2008, REG. NO. 1085883, DATED 2-19-2009, EXPIRES 12-15-2018.

PRIORITY CLAIMED UNDER SEC. 44(D) ON MEXICO APPLICATION NO. 980065, FILED 12-15-2008, REG. NO. 108883, DATED 2-19-2009, EXPIRES 12-15-2018.

NO CLAIM IS MADE TO THE EXCLUSIVE RIGHT TO USE "LAS MOMIAS DE GUANAJUATO" APART FROM THE MARK AS SHOWN IN RELATION TO BOOKS IN THE FIELD OF HISTORY AND ARCHEOLOGY, COMIC BOOKS, COMIC STRIPS, MAGAZINES FEATURING HISTORY AND ARCHEOLOGY, AND PAMPHLETS IN THE FIELD OF HISTORY AND ARCHEOLOGY, APART FROM THE MARK AS SHOWN.

THE MARK CONSISTS OF FIVE VERTICAL FIGURES, EACH HAVING A DOT ON TOP, SIMILAR TO FIVE LOWER CASE LETTERS "I", FOLLOWED BY THE STACKED WORDING "LAS MOMIAS" AND "DE GUANAJUATO" IN STYLIZED LETTERS, THERE IS A SINGLE HORIZONTAL LINE UNDER THE "O" IN "GUANAJUATO".

THE ENGLISH TRANSLATION OF THE WORDS "LAS MOMIAS DE" IN THE MARK IS "THE MUMMIES OF."

CLASS 16—PAPER GOODS AND PRINTED MATTER

FOR ADHESIVE LABELS; ADHESIVE-APPLYING MACHINES FOR HOME AND OFFICE USE; BOOK ENDS; BOOK HOLDERS; BOOK MARKERS; BOOKS IN THE FIELD OF HISTORY AND ARCHEOLOGY; CALENDARS; CASES FOR CHECKS; COASTERS OF PAPER; COMIC BOOKS; COMIC STRIPS; DOCUMENT PORTFOLIOS; ELECTRIC PENCIL SHARPENERS; ENTRY TICKETS; ENVELOPES; ERASERS; FOLDERS; GIFT WRAPPING PAPER; LETTER OPENERS; MAGAZINES FEATURING HISTORY AND ARCHEOLOGY; MECHANICAL PENCIL SHARPENERS; NEWSPAPERS; NOTE BOOKS; PAMPHLETS IN THE FIELD OF HISTORY AND ARCHEOLOGY; PAPER BAGS FOR PACKAGING; PAPER CUTTERS; PAPER NAPKINS; PAPER SHOPPING BAGS; PEN AND PENCIL CASES; PEN AND PENCIL HOLDERS; PEN CASES; PENCIL SHARPENERS; PENCILS; PENS; PHOTOGRAPH MOUNTS; PLASTIC BAGS FOR PACKAGING; POSTERS; PRINTED ADVERTISING BOARDS OF PAPER OR CARDBOARD; RUBBER STAMP; STICKERS; TABLE MATS OF PAPER (U.S. CLS. 2, 5, 22, 23, 29, 37, 38 AND 50).

CLASS 18—LEATHER GOODS

FOR ALL PURPOSE SPORT BAGS; ATHLETIC BAGS; BACKPACKS; BAGS FOR SPORTS; BEACH BAGS; BOOK BAGS; BRIEFCASES FOR DOCUMENTS; CARD WALLETS; CHANGE PURSES; HANDBAGS; LEATHER BAGS FOR MERCHANDISE PACKAGING; LEATHER SHOPPING BAGS; LUGGAGE AND TRUNKS; SUITCASES; UMBRELLAS AND PARASOLS; WALKING STICKS; WALLETS (U.S. CLS. 1, 2, 3, 22 AND 41).

CLASS 25—CLOTHING

FOR APRONS; BELTS; BERETS; BOXER BRIEFS; BOXER SHORTS; CAPS; FOOTWEAR; HATS; JACKETS; MASQUERADE COSTUMES AND MASKS SOLD IN CONNECTION THEREWITH; PAJAMAS; PANTS; RAINCOATS; SANDALS; SCARVES; SHIRTS; SHOES; SHORTS; SKIRTS; SLEEP MASKS; SLIPPERS; SNEAKERS; SOCKS; SWEATERS; T-SHIRTS; UNIFORMS; VESTS (U.S. CLS. 22 AND 39).

PAULA MAHONEY, EXAMINING ATTORNEY

SN 77-749,885. REALTY EXECUTIVES INTERNATIONAL, INC., PHOENIX, AZ. FILED 6-2-2009.

SEARCHHOMES.COM

THE MARK CONSISTS OF STANDARD CHARACTERS WITHOUT CLAIM TO ANY PARTICULAR FONT, STYLE, SIZE, OR COLOR.

SEC. 2(F).

CLASS 35—ADVERTISING AND BUSINESS

FOR PROVIDING COMPREHENSIVE COMMUNITY INFORMATION TO POTENTIAL HOME BUYERS, NAMELY, INFORMATION ABOUT DEMOGRAPHICS, TAXES AND SHOPPING (U.S. CLS. 100, 101 AND 102).

FIRST USE 9-26-2000; IN COMMERCE 9-26-2000.

CLASS 36—INSURANCE AND FINANCIAL

FOR PROVIDING MORTGAGE LENDING AND RATE INFORMATION (U.S. CLS. 100, 101 AND 102).

FIRST USE 9-26-2000; IN COMMERCE 9-26-2000.

CLASS 39—TRANSPORTATION AND STORAGE

FOR PROVIDING COMPREHENSIVE COMMUNITY INFORMATION TO POTENTIAL HOME BUYERS, NAMELY, INFORMATION ABOUT LOCAL UTILITIES, TRANSPORTATION, MOVING AND RELOCATION SERVICES IN THE NATURE OF MOVING VAN SERVICES (U.S. CLS. 100 AND 105).

FIRST USE 9-26-2000; IN COMMERCE 9-26-2000.

CLASS 41—EDUCATION AND ENTERTAINMENT

FOR PROVIDING COMPREHENSIVE COMMUNITY INFORMATION TO POTENTIAL HOME BUYERS, NAMELY, INFORMATION ABOUT SCHOOLS, ENTERTAINMENT, CULTURAL EVENTS, RECREATIONAL PARK SERVICES AND SPORTS (U.S. CLS. 100, 101 AND 107).

FIRST USE 9-26-2000; IN COMMERCE 9-26-2000.
JESSICA A. POWERS, EXAMINING ATTORNEY

SN 77-760,252. 1400446 ALBERTA LTD., EDMONTON, ALBERTA, CANADA, FILED 6-15-2009.



OWNER OF CANADA REG. NO. TMA813844, DATED 12-12-2011, EXPIRES 12-12-2026.

NO CLAIM IS MADE TO THE EXCLUSIVE RIGHT TO USE "STERLING", APART FROM THE MARK AS SHOWN.

THE MARK CONSISTS OF THE WORDS "METALSMITHS STERLING" WITH THE DESIGN OF A BUTTERFLY WITH A SHIELD IN THE CENTER AND THE STYLIZED LETTER "M" IN THE CENTER OF THE SHIELD AND A CROWN PLACED ABOVE THE SHIELD.

SEC. 2(F) AS TO "METALSMITHS".

CLASS 9—ELECTRICAL AND SCIENTIFIC APPARATUS

FOR SUNGLASSES (U.S. CLS. 21, 23, 26, 36 AND 38).

CLASS 14—JEWELRY

FOR JEWELRY, NAMELY, GOLD, GOLD PLATED OR STERLING SILVER PINS, BROOCHES, RINGS, EARRINGS CHARMS, BRACELETS, BANGLES, BANDS, NECKLACES, PENDANTS AND BODY JEWELRY, WITH OR WITHOUT BEADS, PEARLS, AND PRECIOUS AND SEMI-PRECIOUS GEMSTONES; WATCHES (U.S. CLS. 2, 27, 28 AND 50).

CLASS 18—LEATHER GOODS

FOR WALLET, PURSES AND HANDBAGS (U.S. CLS. 1, 2, 3, 22 AND 41).

JANICE KIM, EXAMINING ATTORNEY

SN 77-777,265. SAFARILAND, LLC, JACKSONVILLE, FL. FILED 7-9-2009.



OWNER OF U.S. REG. NOS. 1,808,879, 1,833,637 AND 1,873,761.

THE MARK CONSISTS OF THE STYLIZED IMAGE OF AN IMPALA.

CLASS 1—CHEMICALS

FOR FINGERPRINT DEVELOPING CHEMICALS, FINGERPRINT DUSTING POWDER, NARCOTIC IDENTIFICATION REAGENTS, ANALYTICAL REAGENTS FOR IN-LABORATORY AND FIELD USE (U.S. CLS. 1, 5, 6, 10, 26 AND 46).

CLASS 3—COSMETICS AND CLEANING PREPARATIONS

FOR DEGREASING PREPARATIONS AND CLEANERS FOR USE ON VEHICLES; FIREARM CLEANING PREPARATIONS IN THE NATURE OF SOLVENTS FOR REMOVING CARBON BUILDUP (U.S. CLS. 1, 4, 6, 50, 51 AND 52).

CLASS 4—LUBRICANTS AND FUELS

FOR FOOTPRINT IMPRESSION FORMULATIONS FOR FORENSIC USE, NAMELY, CHEMICAL BASED WAXES AND ORGANIC-BASE WAXES; GUN OIL; LUBRICATING OILS AND ALL PURPOSE LUBRICANTS (U.S. CLS. 1, 6 AND 15).

CLASS 5—PHARMACEUTICALS

FOR KITS CONTAINING MEDICAL DIAGNOSTIC REAGENTS FOR DRUG TESTING (U.S. CLS. 6, 18, 44, 46, 51 AND 52).

CLASS 6—METAL GOODS

FOR HANDCUFFS; HANDCUFF CASES; METAL LEG RESTRAINTS; METAL BUILDINGS IN THE NATURE OF STRUCTURAL STEEL GUARD BOOTHS AND FORTIFIED ARMORED POSITIONS; BULLET-RESISTANT MODULAR WALL SYSTEMS COMPRISED OF METAL MODULAR WALLS (U.S. CLS. 2, 12, 13, 14, 23, 25 AND 50).

CLASS 8—HAND TOOLS

FOR UTILITY KNIFE CASES; LEATHER TOOL BELTS; BATONS FOR SELF-DEFENSE; METAL TIPS FOR POLICE BATONS (U.S. CLS. 23, 28 AND 44).

CLASS 9—ELECTRICAL AND SCIENTIFIC APPARATUS

FOR BODY ARMOR; BALLISTIC VESTS; RADIO HOLDERS; CASSETTE RECORDER CASES; GAS MASK POUCHES; CONCEALED BULLET-RESISTANT PANELS USED IN BODY ARMOR; PORTABLE BALLISTIC SHIELDS; NIGHT VISION SCOPES; REFLECTIVE ULTRA-VIOLET IMAGING SYSTEMS COMPRISED OF NIGHT VISION SCOPES, SHORTWAVE ULTRA-VIOLET LIGHTS AND LENSES; SCALES; VHS TAPES, CDS AND DVDS FEATURING EDUCATIONAL TRAINING VIDEOS IN THE FIELDS OF MILITARY, PARAMILITARY AND POLICE WORK (U.S. CLS. 21, 23, 26, 36 AND 38).

CLASS 10—MEDICAL APPARATUS

FOR DISPOSABLE MASKS FOR MOUTH-TO-MOUTH RESUSCITATION; BLOOD DRAWING APPARATUS FOR USE IN DRUG TESTING KITS (U.S. CLS. 26, 39 AND 44).

CLASS 13—FIREARMS

FOR HOLSTERS; MILITARY AND POLICE DUTY GEAR, NAMELY, REVOLVER SPEEDLOADER HOLDERS; AMMO CADDIES; CARTRIDGE POUCHES; GUN CASES; CARTRIDGE BELTS; HOLSTER ADAPTERS; MAGAZINE HOLDERS FOR WEAPONS; NON-EXPLOSIVE DEFENSIVE WEAPONS IN THE NATURE OF AN IRRITANT PACKAGED IN AEROSOL CONTAINERS; KITS FOR CLEANING AND PRESERVING FIREARMS COMPOSED OF GUN CLEANING BRUSHES, CLOSER CUPS, AND DECAPPERS; SLINGS FOR CARRYING FIREARMS; CASES SOLD EMPTY FOR CANISTERS OF PEPPER GAS AND OTHER DEFENSIVE IRRITANTS (U.S. CLS. 2 AND 9).

CLASS 16—PAPER GOODS AND PRINTED MATTER

FOR POLICE NOTEBOOK AND CITATION HOLDERS; CASES FOR HOLDING IDENTIFICATION SUCH AS DRIVER'S LICENSES; FINGERPRINT KITS; PAPER TAGS, PAPER FLAGS AND MARKERS FOR EVIDENCE IDENTIFICATION; PRE-INKED FINGERPRINT PADS; FINGERPRINT PAPER; ADHESIVE-BACKED EVIDENCE TAPES AND LABELS (U.S. CLS. 2, 5, 22, 23, 29, 37, 38 AND 50).

CLASS 17—RUBBER GOODS

FOR PLASTIC EVIDENCE TAPE (U.S. CLS. 1, 5, 12, 13, 35 AND 50).

CLASS 18—LEATHER GOODS

FOR ALL-PURPOSE UTILITY BAGS AND GEAR BAGS (U.S. CLS. 1, 2, 3, 22 AND 41).

CLASS 20—FURNITURE AND ARTICLES NOT OTHERWISE CLASSIFIED

FOR NONMETAL KEY HOLDERS; PLASTIC HANDCUFF STRIP RESTRAINTS (U.S. CLS. 2, 13, 22, 25, 32 AND 50).

CLASS 22—CORDAGE AND FIBERS

FOR PLASTIC EVIDENCE BAGS (U.S. CLS. 1, 2, 7, 19, 22, 42 AND 50).

CLASS 25—CLOTHING

FOR GLOVES; APPAREL, NAMELY, SHIRTS, PANTS, COATS, JACKETS, HEADWEAR (U.S. CLS. 22 AND 39).
DANIEL CAPSHAW, EXAMINING ATTORNEY

SN 77-796,422. NATIONWIDE CREDIT, INC., KENNESAW, GA. FILED 8-4-2009.



OWNER OF U.S. REG. NOS. 1,932,669, 3,144,339 AND 3,429,456.

NO CLAIM IS MADE TO THE EXCLUSIVE RIGHT TO USE "CREDIT, INC.", APART FROM THE MARK AS SHOWN.

THE MARK CONSISTS OF AN ARC DESIGN AND THE WORDING "NCI NATIONWIDE CREDIT, INC."

SEC. 2(F) AS TO "NATIONWIDE CREDIT, INC."

CLASS 35—ADVERTISING AND BUSINESS

FOR BUSINESS PROCESS OUTSOURCING SERVICES IN THE FIELD OF DEBT COLLECTION; CUSTOMER RELATIONSHIP MANAGEMENT; BUSINESS CONSULTING SERVICES IN THE FIELD OF SPEND MANAGEMENT; MANAGEMENT OF TELEPHONE CALL CENTERS FOR OTHERS (U.S. CLS. 100, 101 AND 102).

FIRST USE 8-1-2000; IN COMMERCE 8-1-2000.

CLASS 36—INSURANCE AND FINANCIAL

FOR FINANCIAL SERVICES, NAMELY, COLLECTION AGENCIES, COLLECTION OF DEBT, CREDIT RECOVERY AND COLLECTION, DEBT RECOVERY AND COLLECTION AGENCIES, CONTINGENCY COLLECTION OF DEBTS, MORTGAGE DEBT COLLECTION SERVICES; FIRST PARTY BUSINESS DEBT COLLECTIONS (U.S. CLS. 100, 101 AND 102).

FIRST USE 8-1-2000; IN COMMERCE 8-1-2000.

CLASS 45—PERSONAL AND LEGAL SERVICES

FOR LEGAL SERVICES; SKIP TRACING SERVICES (U.S. CLS. 100 AND 101).

FIRST USE 8-1-2000; IN COMMERCE 8-1-2000.

VERNA BETH RIRIE, EXAMINING ATTORNEY

SN 77-845,920. ACCESS FLEET, INC., GARDNERVILLE, NV. FILED 10-9-2009.

ACCESS FLEET

THE MARK CONSISTS OF STANDARD CHARACTERS WITHOUT CLAIM TO ANY PARTICULAR FONT, STYLE, SIZE, OR COLOR.

NO CLAIM IS MADE TO THE EXCLUSIVE RIGHT TO USE "FLEET", APART FROM THE MARK AS SHOWN.

CLASS 35—ADVERTISING AND BUSINESS

FOR CUSTOMER RELATIONSHIP MANAGEMENT OF MERCHANT CLIENTS AND OF THE RELATIONSHIP BETWEEN MERCHANT CLIENTS AND CREDIT, DEBIT AND FLEET CARD ISSUERS AND PROCESSORS (U.S. CLS. 100, 101 AND 102).

FIRST USE 4-16-2007; IN COMMERCE 4-16-2007.

CLASS 36—INSURANCE AND FINANCIAL

FOR FINANCIAL MANAGEMENT OF MERCHANT CLIENTS AND OF THE RELATIONSHIP BETWEEN MERCHANT CLIENTS AND CREDIT, DEBIT AND FLEET CARD ISSUERS AND PROCESSORS (U.S. CLS. 100, 101 AND 102).

FIRST USE 4-16-2007; IN COMMERCE 4-16-2007.

ANDREW RHIM, EXAMINING ATTORNEY

SN 77-881,473. HOME FIELD GRILL LLC, DBA HOMEFIELD GRILL, ROUND ROCK, TX. FILED 11-27-2009.

SN 77-894,916. ZYNGA INC., SAN FRANCISCO, CA. FILED 12-16-2009.



The logo for HomeField grill features the word "HomeField" in a bold, black, sans-serif font, followed by "grill" in a smaller, black, cursive font. A stylized orange and yellow flame is positioned above the letter "i" in "grill". Below the text is a thick, black horizontal line that tapers at both ends, resembling a baseball bat.

NO CLAIM IS MADE TO THE EXCLUSIVE RIGHT TO USE "GRILL", APART FROM THE MARK AS SHOWN.

THE COLOR(S) BLACK, ORANGE, YELLOW IS/ARE CLAIMED AS A FEATURE OF THE MARK.

THE MARK CONSISTS OF THE STYLIZED WORDING "HOMEFIELD GRILL" APPEARING IN BLACK WITH A BLACK STYLIZED BASEBALL BAT RUNNING UNDERNEATH THE LENGTH OF THE WORDING. A FLAME DESIGN OUTLINED IN BLACK, WITH A GRADIENT FROM ORANGE TO YELLOW, APPEARS IN PLACE OF THE DOT IN THE "I" IN "GRILL".

CLASS 41—EDUCATION AND ENTERTAINMENT

FOR AMUSEMENT CENTERS (U.S. CLS. 100, 101 AND 107).

FIRST USE 6-25-2010; IN COMMERCE 6-25-2010.

CLASS 43—HOTEL AND RESTAURANT SERVICES

FOR BAR AND RESTAURANT SERVICES (U.S. CLS. 100 AND 101).

FIRST USE 6-25-2010; IN COMMERCE 6-25-2010.

AMY KERTGATE, EXAMINING ATTORNEY

SN 77-894,253. EVANS TIRE AND SERVICE CENTERS, ESCONDIDO, CA. FILED 12-16-2009.



The logo for Evans Tire & Service Centers features the words "EVANS TIRE" in large, bold, purple, sans-serif capital letters, with "& SERVICE CENTERS" in smaller, bold, purple, sans-serif capital letters below it. Underneath the text is the tagline "WHY SHOP ANYWHERE ELSE?" in a smaller, bold, black, sans-serif font.

NO CLAIM IS MADE TO THE EXCLUSIVE RIGHT TO USE "TIRE & SERVICE CENTERS", APART FROM THE MARK AS SHOWN.

THE COLOR(S) PURPLE AND BLACK IS/ARE CLAIMED AS A FEATURE OF THE MARK.

THE MARK CONSISTS OF "EVANS TIRE" IN BOLD BIG CAPITAL LETTERS OVER A SMALLER CAPITAL "& SERVICE CENTERS" FOLLOWED BY "WHY SHOP ANYWHERE ELSE" ON THE BOTTOM RIGHT CORNER. THE WORDING "EVANS TIRE & SERVICE CENTERS" APPEARS IN PURPLE. THE WORDING "WHY SHOP ANYWHERE ELSE" APPEARS IN BLACK.

CLASS 35—ADVERTISING AND BUSINESS

FOR RETAIL STORE SERVICES FEATURING AUTOMOBILE TIRES AND PARTS THAT ACCOMPANY TIRES (U.S. CLS. 100, 101 AND 102).

CLASS 37—CONSTRUCTION AND REPAIR

FOR REPAIR AND MAINTENANCE OF AUTOMOBILES (U.S. CLS. 100, 103 AND 106).

DORITT L. CARROLL, EXAMINING ATTORNEY

HOTEL WORLD

THE MARK CONSISTS OF STANDARD CHARACTERS WITHOUT CLAIM TO ANY PARTICULAR FONT, STYLE, SIZE, OR COLOR.

NO CLAIM IS MADE TO THE EXCLUSIVE RIGHT TO USE "HOTEL", APART FROM THE MARK AS SHOWN.

CLASS 9—ELECTRICAL AND SCIENTIFIC APPARATUS

FOR DOWNLOADABLE COMPUTER SOFTWARE FOR USE ON WIRELESS DEVICES AND COMPUTERS FOR TRANSMISSION OF INFORMATION IN THE FIELD OF SOCIAL NETWORKING, COMPUTER GAME SOFTWARE, VIDEO GAME SOFTWARE, AND GAME RELATED COMPUTER SOFTWARE APPLICATIONS FOR SOCIAL NETWORKING; INTERACTIVE VIDEO GAME PROGRAMS; DOWNLOADABLE ELECTRONIC GAME SOFTWARE AND GAME RELATED COMPUTER SOFTWARE APPLICATIONS FOR TRANSMISSION OF DATA AND INFORMATION IN THE FIELD OF SOCIAL NETWORKING THAT MAY BE ACCESSED VIA THE INTERNET, COMPUTERS AND WIRELESS DEVICES; COMPUTER SOFTWARE TO ENABLE UPLOADING, POSTING, SHOWING, DISPLAYING, TAGGING, BLOGGING, SHARING OR OTHERWISE PROVIDING ELECTRONIC MEDIA OR INFORMATION TO THIRD PARTIES IN THE FIELDS OF VIRTUAL COMMUNITIES, ELECTRONIC GAMING, ENTERTAINMENT, AND GENERAL INTEREST VIA THE INTERNET OR OTHER COMMUNICATIONS NETWORKS (U.S. CLS. 21, 23, 26, 36 AND 38).

CLASS 41—EDUCATION AND ENTERTAINMENT

FOR ENTERTAINMENT SERVICES, NAMELY, PROVIDING ON-LINE COMPUTER GAMES, ENHANCEMENTS FOR ON-LINE COMPUTER GAMES, GAME SOFTWARE APPLICATIONS FOR TRANSMISSION OF INFORMATION IN THE FIELD OF SOCIAL NETWORKING, PROVIDING REVIEWS OF COMPUTER GAMES, AND INFORMATION RELATING TO COMPUTER GAMES; PROVIDING AN INTERNET WEBSITE PORTAL IN THE FIELD OF COMPUTER GAMES AND GAMING; ENTERTAINMENT SERVICES, NAMELY, PROVIDING VIRTUAL ENVIRONMENTS IN WHICH USERS CAN INTERACT THROUGH SOCIAL GAMES FOR RECREATIONAL, LEISURE OR ENTERTAINMENT PURPOSES (U.S. CLS. 100, 101 AND 107).

KATHRYN COWARD, EXAMINING ATTORNEY

SN 77-895,673. IRVING TISSUE CORPORATION, DIEPPE, NEW BRUNSWICK, CANADA, FILED 12-17-2009.

RFPTREES.COM

THE MARK CONSISTS OF STANDARD CHARACTERS WITHOUT CLAIM TO ANY PARTICULAR FONT, STYLE, SIZE, OR COLOR.

PRIORITY CLAIMED UNDER SEC. 44(D) ON CANADA APPLICATION NO. 1462247, FILED 12-9-2009.

OWNER OF CANADA REG. NO. TMA812,191, DATED 11-21-2011, EXPIRES 11-21-2026.

CLASS 16—PAPER GOODS AND PRINTED MATTER

FOR FACIAL TISSUE, BATHROOM TISSUE, PAPER TOWELS, PAPER NAPKINS; PAPER AND DISPOSABLE DIAPERS (U.S. CLS. 2, 5, 22, 23, 29, 37, 38 AND 50).

CLASS 35—ADVERTISING AND BUSINESS

FOR ASSOCIATION SERVICES, NAMELY, PROMOTING THE INTERESTS OF THE FOREST, PAPER AND WOOD PRODUCTS INDUSTRY, AND PROMOTING PUBLIC AWARENESS OF ENVIRONMENTAL ISSUES AND INITIATIVES OF THE FOREST, PAPER AND WOOD PRODUCTS INDUSTRY (U.S. CLS. 100, 101 AND 102).

DARRYL SPRULL, EXAMINING ATTORNEY

SN 77-941,637. JENS STEENBERG, PINCHER CREEK, ALBERTA, CANADA, FILED 2-22-2010.



OWNER OF CANADA REG. NO. 801004, DATED 6-29-2011, EXPIRES 6-29-2026.

THE MARK CONSISTS OF THE WORDING "EARTH CONNECTING TO UNIVERSE" AND A DESIGN ELEMENT COMPRISING A GLOBE WITH PYRAMIDS ACROSS THE TOP ALL INSIDE OF A RECTANGLE.

SN 77-911,373. BEST OF ISRAEL TRAVEL LLC, SYOSSET, NY. FILED 1-13-2010.

THE BEST OF ISRAEL

THE MARK CONSISTS OF STANDARD CHARACTERS WITHOUT CLAIM TO ANY PARTICULAR FONT, STYLE, SIZE, OR COLOR.

NO CLAIM IS MADE TO THE EXCLUSIVE RIGHT TO USE "ISRAEL", APART FROM THE MARK AS SHOWN. SEC. 2(F).

CLASS 10—MEDICAL APPARATUS

FOR ALTERNATIVE MEDICAL DEVICE, NAMELY, A WOODEN PYRAMID THAT DIFFUSES AND EMITS POSITIVE AND CALMING WAVES WHICH IS USED IN THE FIELD OF PHYSICAL, MENTAL, EMOTIONAL, SPIRITUAL AND ENERGETIC HEALING (U.S. CLS. 26, 39 AND 44).

CLASS 44—MEDICAL, BEAUTY AND AGRICULTURAL SERVICES

FOR PROVIDING HEALTH CARE HEALING THERAPY IN THE FIELD OF PHYSICAL, MENTAL, EMOTIONAL, SPIRITUAL AND ENERGETIC HEALING (U.S. CLS. 100 AND 101).

LURIE KAUFMAN, EXAMINING ATTORNEY

CLASS 39—TRANSPORTATION AND STORAGE

FOR ORGANIZATION OF EXCURSIONS, SIGHTSEEING TOURS, HOLIDAYS, TOURS AND TRAVEL; PROVIDING INFORMATION, NEWS AND COMMENTARY IN THE FIELD OF TRAVEL; TRAVEL AND TOUR INFORMATION SERVICE; TRAVEL AND TOUR TICKET RESERVATION SERVICE (U.S. CLS. 100 AND 105).

FIRST USE 0-0-2006; IN COMMERCE 0-0-2006.

SN 77-943,773. TELEMUNDO NETWORK GROUP LLC, HIALEAH, FL. FILED 2-24-2010.

MUJER DE HOY**CLASS 41—EDUCATION AND ENTERTAINMENT**

FOR SPECIAL EVENT, PARTY AND WEDDING PLANNING, COORDINATION AND CONSULTATION SERVICES (U.S. CLS. 100, 101 AND 107).

FIRST USE 0-0-2006; IN COMMERCE 0-0-2006.

THE MARK CONSISTS OF STANDARD CHARACTERS WITHOUT CLAIM TO ANY PARTICULAR FONT, STYLE, SIZE, OR COLOR.

NO CLAIM IS MADE TO THE EXCLUSIVE RIGHT TO USE "MUJER", APART FROM THE MARK AS SHOWN.

THE ENGLISH TRANSLATION OF "MUJER DE HOY" IN THE MARK IS "TODAY'S WOMAN".

CLASS 43—HOTEL AND RESTAURANT SERVICES

FOR MAKING HOTEL RESERVATIONS FOR OTHERS; PROVIDING ADVICE TO TOURISTS AND BUSINESS TRAVELERS ON HOTEL AND RESTAURANT DESTINATIONS; TRAVEL AGENCY SERVICES, NAMELY, MAKING RESERVATIONS AND BOOKING FOR TEMPORARY LODGING (U.S. CLS. 100 AND 101).

FIRST USE 0-0-2006; IN COMMERCE 0-0-2006.

NICHOLAS COLEMAN, EXAMINING ATTORNEY

CLASS 9—ELECTRICAL AND SCIENTIFIC APPARATUS

FOR COMPUTER MOUSE; DECORATIVE MAGNETS; PRERECORDED DIGITAL VIDEO DISKS FEATURING TELEVISION PROGRAMS REGARDING CELEBRITY GOSSIP, FASHION, ROMANCE, AND BEAUTY AND HEALTH; SUNGLASSES (U.S. CLS. 21, 23, 26, 36 AND 38).

CLASS 16—PAPER GOODS AND PRINTED MATTER

FOR BANNERS OF PAPER; BUMPER STICKERS; CALENDARS; DIARIES; GENERAL PURPOSE PLASTIC BAGS; GIFT BAGS; NOTEBOOKS; NOTEPADS; PAPER BAGS; PENCILS; PENS; PHOTOGRAPH ALBUMS; POSTERS; PUBLICATIONS, NAMELY, BOOKS, NEWSLETTERS AND MAGAZINES IN THE FIELDS OF TELEVISION PROGRAMS REGARDING CELEBRITY GOSSIP, FASHION, ROMANCE, AND BEAUTY AND HEALTH; SCRAP BOOKS; STICKERS; STICKERS AND TRANSFERS (U.S. CLS. 2, 5, 22, 23, 29, 37, 38 AND 50).

CLASS 18—LEATHER GOODS

FOR BACKPACKS, BOOK BAGS, SPORTS BAGS, BUM BAGS, WALLETS AND HANDBAGS (U.S. CLS. 1, 2, 3, 22 AND 41).

DARRYL SPRUILL, EXAMINING ATTORNEY

SN 77-948,112. MXI CORP., RENO, NV. FILED 3-2-2010.



XOCAI
HEALTHY CHOCOLATE

SN 77-944,106. HELP AT HOME, INC., CHICAGO, IL. FILED 2-24-2010.



NO CLAIM IS MADE TO THE EXCLUSIVE RIGHT TO USE "HELP AT HOME INC.", APART FROM THE MARK AS SHOWN.

THE MARK CONSISTS OF THE DESIGN OF A HOUSE, WITH AN OUTLINE OF THE SUN IN THE BACKGROUND, AND THE WORDS "HELP AT HOME INC." INCORPORATED THEREIN.

CLASS 37—CONSTRUCTION AND REPAIR

FOR CLEANING OF RESIDENTIAL HOMES FOR PERSONS REQUIRING HOUSEHOLD ASSISTANCE; LAUNDRY SERVICES, IRONING (U.S. CLS. 100, 103 AND 106).

FIRST USE 5-10-2001; IN COMMERCE 5-10-2001.

CLASS 39—TRANSPORTATION AND STORAGE

FOR TRANSPORTATION OF PASSENGERS, NAMELY, ADULTS, ELDERLY, DISABLED, AND CHILDREN (U.S. CLS. 100 AND 105).

FIRST USE 5-10-2001; IN COMMERCE 5-10-2001.

CLASS 44—MEDICAL, BEAUTY AND AGRICULTURAL SERVICES

FOR HOME NURSING; HOME HEALTH AID NURSING AND HOME CERTIFIED NURSING SERVICES; HOSPICE SERVICE; PHYSICAL THERAPY; SPEECH THERAPY (U.S. CLS. 100 AND 101).

FIRST USE 5-10-2001; IN COMMERCE 5-10-2001.
TOBY BULLOFF, EXAMINING ATTORNEY

OWNER OF U.S. REG. NO. 3,940,089.
NO CLAIM IS MADE TO THE EXCLUSIVE RIGHT TO USE "HEALTHY CHOCOLATE", APART FROM THE MARK AS SHOWN.

THE MARK CONSISTS OF A COCOA BEAN AND THREE ACAI BERRIES ABOVE THE TEXT "XOCAI HEALTHY CHOCOLATE".

CLASS 30—STAPLE FOODS

FOR CHOCOLATE-BASED MEAL REPLACEMENT BARS (U.S. CL. 46).

CLASS 32—LIGHT BEVERAGES

FOR ENERGY DRINKS (U.S. CLS. 45, 46 AND 48).
APRIL HESIK, EXAMINING ATTORNEY

SN 77-950,613. KUBOTA CORPORATION, OSAKA, JAPAN, FILED 3-4-2010.

Kubota
For Earth, For Life

PRIORITY CLAIMED UNDER SEC. 44(D) ON JAPAN APPLICATION NO. 2010-015518, FILED 3-2-2010, REG. NO. 5459166, DATED 12-22-2011, EXPIRES 12-22-2021.

OWNER OF U.S. REG. NOS. 1,775,620, 2,916,907 AND OTHERS.

THE MARK CONSISTS OF THE WORD "KUBOTA" IN STYLIZED FORM BENEATH WHICH THE PHRASE "FOR EARTH, FOR LIFE" APPEARS.

CLASS 4—LUBRICANTS AND FUELS

FOR LUBRICATING OILS BEING INDUSTRIAL LUBRICANTS; LUBRICATING GREASES (U.S. CLS. 1, 6 AND 15).

CLASS 6—METAL GOODS

FOR PIPES OF CAST IRON; IRON PIPES; PIPES OF CAST STEEL; METAL ROLLERS FOR GLASS CONVEYANCE; METAL ROLLERS FOR STEEL PLATE CONVEYANCE; HEARTH MATERIALS FOR SLAB HEATING FURNACES, NAMELY, STEEL AND IRON SKID BUTTONS FOR RE-HEATING FURNACES; METAL REACTION TUBES; METAL ROLLERS FOR PAPER-MAKING; METAL JOINTS FOR PIPES; METAL VALVES, NOT BEING PARTS OF MACHINES; STEEL PIPES; DEFORMED PIPES AND TUBES, OF METAL; METAL PIPES; METAL VALVES NOT BEING PARTS OF MACHINES FOR WATER PIPES; CYLINDRICAL JOINTS, OF METAL, FOR PIPES; METAL ELBOWS FOR PIPES; METAL PIPES FOR PIPELINE; METAL BRANCH PIPES; METAL FLANGES; DRAIN PIPES OF METAL; WATER PIPES OF METAL; COLLECTING PIPES OF METAL; METAL MATERIALS FOR BUILDING AND CONSTRUCTION UTILIZING THERMAL EXPANSION MEMBERS FOR PREVENTION OF FIRE, DISASTER OR ACCIDENTS, NAMELY, MEMBERS FOR ATTACHMENT TO COLLECTING DRAINPIPES TO BLOCK DRAIN LINES; METAL TUBES IN THE NATURE OF PYROLYSIS TUBES FOR HYDROCARBON PRODUCTION; METAL TUBES IN THE NATURE OF REACTION TUBES FOR HYDROGEN PRODUCTION; CAST IRON STEELS; METAL SLUICE GATES EQUIPPED WITH DRAIN PUMPS; METAL TUBES FOR INDUSTRIAL USE, NAMELY, CAST STEEL CRACKING TUBES FOR PYROLYSIS FURNACES FOR USE IN PETROCHEMICAL INDUSTRY; METAL TUBES FOR INDUSTRIAL USE, NAMELY, CRACKING TUBES FOR INDUSTRIAL FURNACES (U.S. CLS. 2, 12, 13, 14, 23, 25 AND 50).

CLASS 7—MACHINERY

FOR POWER-OPERATED BLOWERS; PUMPS, NAMELY, VANE PUMPS, ROTARY PUMPS, MIXED FLOW PUMPS, AXIAL FLOW PUMPS, CENTRIFUGAL PUMPS AND VACUUM PUMPS FOR USE IN AGRICULTURAL IRRIGATION AND DRAINAGE, FOR USE IN WATERWORKS, FOR USE IN SEWAGE SYSTEM, FOR USE IN THERMAL POWER SYSTEM, FOR USE IN BUILDING AIR CONDITIONING AND FOR USE IN INDUSTRIAL WATERWORKS; PARTS, ACCESSORIES AND FITTINGS OF PUMPS, NAMELY, PUMP PACKINGS, PUMP BEARINGS, PUMP SLEEVES, PUMP CASINGS AND PUMP SLIDING MEMBERS; DRAIN PUMPS; SLURRY PUMPS; CENTRIFUGAL PUMPS; VACUUM PUMPS; PUMP IMPELLERS; BEARINGS AS PARTS OF MACHINES, NAMELY, PUMP BEARINGS; WATER-TIGHT PACKINGS FOR INSERTING BETWEEN A PUMP CASING AND PUMP BEARINGS AND FOR INSERTING IN A SPLIT PUMP CASING; LUBRICATION APPARATUS, NAMELY, LUBRICATION MACHINES; PUMP CONTROLLERS, NAMELY, PUMP CONTROL VALVES; WATER TURBINES FOR USE IN HYDRO-ELECTRIC POWER GENERATION; HYDRAULIC GENERATORS; POWER TRANSMISSION DEVICES, NAMELY, POWER TRANSMISSIONS FOR MACHINES; MILL ROLLS, NAMELY, ROUGHING WORK ROLLS AND PLATE MILL-WORK ROLLS FOR USE IN HOT STRIP MILLS, FINISHING WORK ROLLS FOR USE IN HOT STRIP MILLS, PINCH ROLLS FOR USE IN DOWN COILERS, INTERMEDIATE AND FINISHING ROLLS FOR USE IN HEAVY SECTION MILLS, ROUGHING ROLLS FOR USE IN MEDIUM AND LIGHT SECTION MILLS, FINISHING ROLLS FOR USE IN MEDIUM AND LIGHT SECTION MILLS, EDGER ROLLS, HORIZONTAL ROLLS FOR USE IN UNIVERSAL MILLS, AND VERTICAL ROLLS FOR USE IN UNIVERSAL MILLS; METAL-WORKING MACHINES, NAMELY, MILLS, BENDING MACHINES, BORING MACHINES, BROACHING MACHINES, CUTTING MACHINES, DRILLING MACHINES, GRINDING MACHINES, HORNING MACHINES, LAPPING MACHINES, MACHINING CENTERS, MILLING MACHINES, PERFORATING MACHINES, PLANING MACHINES, SHAPING MACHINES, SHEARING MACHINES, AND SLOTTING MACHINES; METALWORKING MACHINE TOOLS; METAL VALVES BEING MACHINE ELEMENTS NOT FOR LAND VEHICLES; WASTE COMPACTING MACHINES AND APPARATUS; WASTE CRUSHING MACHINES AND APPARATUS; WASTE SMASHING MACHINES AND APPARATUS; WASTE PROCESSING MACHINES AND APPARATUS FOR HOUSEHOLD USE, NAMELY, COMPOSTERS AND WASTE COMPACTORS; CERAMIC

MEMBRANE FILTRATION APPARATUS, ORGANIC MEMBRANE FILTRATION APPARATUS, AND MEMBRANE FILTRATION APPARATUS, NAMELY, FILTRATION APPARATUS FOR USE IN THE PURIFICATION OF WASTEWATER AND SEWAGE; FILTERS FOR MEMBRANE FILTRATION APPARATUS AND FILTER UNITS FOR MEMBRANE FILTRATION APPARATUS, NAMELY, FILTERS AND FILTER UNITS FOR FILTRATION APPARATUS FOR USE IN THE PURIFICATION OF WASTE WATER AND SEWAGE; FILTER CASINGS FOR FILTRATION APPARATUS FOR USE IN THE PURIFICATION OF WASTE WATER AND SEWAGE; REPLACEMENT MEMBRANE CARTRIDGES FOR MEMBRANE FILTRATION APPARATUS, NAMELY, REPLACEMENT MEMBRANE CARTRIDGES FOR FILTRATION APPARATUS FOR USE IN THE PURIFICATION OF WASTE WATER AND SEWAGE; REPLACEMENT MEMBRANES FOR MEMBRANE FILTRATION APPARATUS, NAMELY, REPLACEMENT MEMBRANES FOR FILTRATION APPARATUS FOR USE IN THE PURIFICATION OF WASTE WATER AND SEWAGE; AERATION TUBES, NAMELY, DIFFUSER TUBES, FOR MEMBRANE FILTRATION APPARATUS, NAMELY, AERATION TUBES FOR FILTRATION APPARATUS FOR USE IN THE PURIFICATION OF WASTE WATER AND SEWAGE; SLUDGE DEHYDRATION MACHINES, NAMELY, MACHINES THAT DEWATER SLUDGE BY COMPACTING THE WATER OR BY CENTRIFUGING THE WATER TO REDUCE THE WATER CONTENT AND VOLUME OF THE SLUDGE; WASTE DEHYDRATION MACHINES, NAMELY, MACHINES THAT DEWATER WASTE BY COMPACTING THE WATER OR BY CENTRIFUGING THE WATER TO REDUCE THE WATER CONTENT AND VOLUME OF THE WASTE; SLUDGE CONVEYORS BEING MACHINES; BLADES FOR WASTE CRUSHING MACHINES; WALK-BEHIND TRACTORS FOR AGRICULTURAL USE, NAMELY, TILLERS; COMBINE HARVESTERS; REAPERS AND BINDERS IN THE NATURE OF HAY BINDING MACHINES; HARVESTING MACHINES, NAMELY, HARVESTERS; POWER TILLERS; CULTIVATION CONTROL MACHINES IN THE NATURE OF POWER-OPERATED CULTIVATORS; THRESHING MACHINES; RICE HUSKERS; FERTILIZER DISTRIBUTING MACHINES IN THE NATURE OF FERTILIZER SPREADERS; REAPERS BEING AGRICULTURAL MACHINES; POWER MACHINES FOR MOWING; SOIL DISINFECTION MACHINES IN THE NATURE OF ATTACHMENTS FOR WORKING VEHICLES, NAMELY, TRACTORS AND TILLERS; DITCHERS BEING PLOUGHS; RIDGERS BEING PLOUGHS; TRANSPLANTING MACHINES, NAMELY, AUTOMATED TRANSPLANTING MACHINES FOR TRANSPLANTING SEEDLINGS; MULCH LAYING MACHINES; MULCH FILM REMOVING MACHINES; SOWERS BEING MACHINES; SOIL SCATTERING MACHINES FOR SEEDLING BOXES; INCUBATORS FOR GERMINATION OF SEEDS AND SEEDLINGS; CULTIVATORS BEING AGRICULTURAL MACHINES; WEEDING MACHINES; AGRICULTURAL MACHINES, NAMELY, BLIGHT PREVENTION MACHINES; VEGETABLE HARVESTING MACHINES IN THE NATURE OF HARVESTERS; VEGETABLE PROCESSING MACHINES, NAMELY, VEGETABLE CUTTING MACHINES, VEGETABLE SLICING MACHINES, VEGETABLE PEELING MACHINES, VEGETABLE GRATING MACHINES AND VEGETABLE SORTING MACHINES; VEGETABLE GRADERS, NAMELY, CARROT LENGTH GRADERS, ROTARY GRADER FOR SORTING VEGETABLES ACCORDING TO SIZE, ROLLER GRADERS FOR GRADING VEGETABLES BY DIAMETER, ELECTRONIC COLOR SORTERS, AND SPECIFIC GRAVITY SEPARATORS; FRUIT GRADERS, NAMELY, ELECTRONIC COLOR SORTERS, SPECIFIC GRAVITY SEPARATORS, AND ELECTRONICAL FRUIT GRADERS; CEREAL GRADERS BEING CEREAL GRATING MACHINES; FOREIGN MATTER SORTING MACHINES; VEGETABLE WASHING MACHINES; VEGETABLE TRIMMING MACHINES; VEGETABLE PACKING MACHINES; VEGETABLE BINDERS BEING MACHINES; NURSERY BOXES BEING PART OF TRANSPLANTING MACHINES; LAWNMOWERS BEING MACHINES; LAWN HUSBANDRY MACHINES, NAMELY, POWER SPRAYERS, ENGINE SET POWER SPRAYERS, BACKPACK POWER MIST SPRAYERS, BACKPACK POWER MIST/DUSTERS; BACKPACK POWER SPRAYERS, HIGH CLEARANCE BOOM SPRAYERS, STEREO SPRAYERS, NAMELY, SELF-PROPELLED ORCHARD SPRAYERS, BOOM SPRAYERS, CARPET DUSTERS, SOIL INJECTORS, SUPER SPOUTTERS, LOW-VOLUME SPRAYERS, SUPER SHUTTLES,

WATER PUMPS, BRUSHCUTTERS, STRING TRIMMERS, BLOWERS, GREEN INJECTORS, GREEN SPRAYERS, AND GREEN SPOUTERS; BACKHOES; CONSTRUCTION MACHINES, NAMELY, EXCAVATORS, BACKHOES, LOADERS, CONCRETE CRUSHERS, ASPHALT CRUSHERS, ROCK CRUSHERS AND DOZERS; PILE-DRIVERS; EARTH AUGERS; EARTH SCRAPERS; TAMPING MACHINES; CROP DRYING MACHINES; INDUSTRIAL RICE RINSING MACHINES; INDUSTRIAL FOOD INGREDIENT MIXERS; INDUSTRIAL RICE OR BARLEY POLISHING MACHINES; SKID-STEER LOADERS; WASHING MACHINES FOR AGRICULTURAL MACHINES; WAX-POLISHING MACHINES FOR AGRICULTURAL MACHINES; ENGINES, OTHER THAN FOR LAND VEHICLES; ENGINE GENERATORS; ENGINE COMPRESSORS; ENGINE-DRIVEN WELDING MACHINES; MACHINE SHAFTS BEING CAMSHAFTS; BEARINGS BEING MACHINE ELEMENTS NOT FOR LAND VEHICLES; SHAFT COUPLINGS OR CONNECTORS BEING MACHINE ELEMENTS NOT FOR LAND VEHICLES; REDUCTION GEARS BEING MACHINE ELEMENTS NOT FOR LAND VEHICLES; SPEED CHANGE GEARS BEING MACHINE ELEMENTS NOT FOR LAND VEHICLES; CAMS IN THE NATURE OF MACHINE ELEMENTS NOT FOR LAND VEHICLES; TOOTHED WHEELS IN THE NATURE OF GEARS BEING MACHINE ELEMENTS NOT FOR LAND VEHICLES; SPRINGS BEING MACHINE ELEMENTS NOT FOR LAND VEHICLES; SHOCK ABSORBERS BEING MACHINE ELEMENTS NOT FOR LAND VEHICLES; POWER TRANSMISSION BELTS BEING MACHINE ELEMENTS NOT FOR LAND VEHICLES; PARTS OF MOTORS AND ENGINES, NAMELY, ASSEMBLY PISTON RINGS, OIL SEALS, INLET VALVES, CYLINDER LINERS, RUBBER ABSORBERS, EXHAUST VALVES, LINER O-RINGS, ASSEMBLY CONNECTING RODS, ASSEMBLY FUEL FILTERS, GASKETS, CAMS, OIL FILTERS, AIR CLEANING ELEMENTS IN THE NATURE OF CARTRIDGES FOR AIR FILTERS FOR ENGINES FOR AGRICULTURAL MACHINES; WATER PUMPS BEING PARTS OF MACHINES, ENGINES OR MOTORS; CRANKCASES FOR MOTORS AND ENGINES; GEAR CASES FOR MOTORS AND ENGINES; CLUTCH HOUSINGS BEING MACHINE PARTS; CRANKSHAFTS FOR MACHINES AND ENGINES; CRANKCASES FOR MACHINES, MOTORS AND ENGINES; CONTROL VALVES FOR ENGINES; CYLINDER BLOCKS FOR ENGINES OTHER THAN FOR LAND VEHICLES; CYLINDER HEADS FOR ENGINES; GEARBOX CASINGS IN THE NATURE OF GEARBOXES OTHER THAN FOR LAND VEHICLES; COUNTER BALANCING WEIGHTS FOR ATTACHMENT TO THE FRONT END OR REAR END OF VEHICLES SUCH AS TRACTORS AND TRANSPORTATION VEHICLES AND MACHINES SUCH AS RICE TRANSPLANTING MACHINES AND TILLING MACHINES TO KEEP ANTEROPOSTERIOR WEIGHT BALANCE WHEN THEY ARE EQUIPPED WITH WORKING ATTACHMENTS SUCH AS FRONT-END LOADERS, BACKHOES, EARTH AUGERS, FERTILIZER APPLICATORS, SEED SOWERS AND WEED KILLER SPREADERS; PISTONS BEING PARTS OF MACHINES OR ENGINES; MACHINE FLY-WHEELS; METAL CAPS BEING PARTS OF MACHINES OR ENGINES; CRANKPIN BEARINGS BEING PARTS OF MACHINES OR ENGINES; MONOBLOCKS BEING PARTS OF ENGINES FOR AGRICULTURAL MACHINES; CYLINDER LINERS BEING PARTS OF MACHINES OR ENGINES; ROD HOUSINGS BEING MACHINE PARTS; CYLINDER HEAD COVERS FOR ENGINES; BEARING CASES BEING MACHINE PARTS; SPEED GOVERNORS FOR ENGINES; NOZZLE HOLDERS FOR ENGINES; FUEL PUMPS FOR ENGINES; WATER FLANGES FOR ENGINES; THERMOSTATS FOR ENGINES; EXHAUST MANIFOLD FOR ENGINES; CLUTCH HOUSINGS BEING MACHINE PARTS OTHER THAN FOR LAND VEHICLES; AXLE CASES FOR MACHINES BEING MACHINE PARTS; HYDRAULIC CYLINDERS; UNIVERSAL JOINTS BEING MACHINE PARTS; CEREAL PROCESSING MACHINES, NAMELY, BARLEY PRESS ROLLERS; CONFECTIONERY MAKING MACHINES; BAKERY MACHINES; FLOUR MILLS; RICE OR BARLEY POLISHING MACHINES; NOODLE MAKING MACHINES; BARLEY SPLITTING MACHINES; RICE MILLS OR RICE MILLING SYSTEMS, NAMELY, RICE MILLING MACHINES, ELECTRIC RICE MILLING MACHINES FOR HOUSEHOLD USE; MIXING MACHINES; COLOR SORTING MACHINES; ROLLS IN THE NATURE OF ROLLER CONVEYORS FOR GLASS CONVEYANCE; ROLLS IN THE NATURE OF ROLLER CONVEYORS

FOR STEEL PLATE CONVEYANCE; SUCTION ROLL SHELLS FOR PAPER MAKING MACHINES; FILLING MACHINES IN THE NATURE OF GAS FILLING DEVICES; FILLING MACHINES IN THE NATURE OF LIQUID FILLING DEVICES; APPARATUS FOR DISPOSING INCINERATED ASH IN INCINERATORS IN THE NATURE OF ATTACHMENTS FOR WORKING VEHICLES SUCH AS TRACTORS AND MACHINES SUCH AS TILLERS; WASTE LANDFILL INSTALLATIONS, NAMELY, WATER INTAKE UNITS, SEDIMENTATION UNITS, FILTRATION UNITS, TOXICS REMOVAL UNITS, EFFLUENT PURIFICATION UNITS AND DEHYDRATION UNITS, ALL BEING COMPONENTS OF WASTE LANDFILL; TOXICS REMOVAL APPARATUS FOR USE IN WASTE LANDFILL INSTALLATIONS, NAMELY, CALCIUM REMOVAL UNITS, CHROMIANCE CONTROL UNITS, HEAVY METAL REMOVAL UNITS, BORON ADSORPTION UNITS, DIOXIN DECOMPOSITION UNITS AND DESALINATION UNITS; PHOTOCHEMICAL DECOMPOSITION APPARATUS FOR USE IN WASTE LANDFILL INSTALLATIONS, NAMELY, CALCIUM REMOVAL UNITS, CHROMIANCE CONTROL UNITS, HEAVY METAL REMOVAL UNITS, BORON ADSORPTION UNITS, DIOXIN DECOMPOSITION UNITS AND DESALINATION UNITS; DESALINATION UNITS FOR USE IN WASTE LANDFILL INSTALLATIONS; CHELATING ADSORPTION TOWERS FOR USE IN WASTE LANDFILL INSTALLATIONS; CONTACT AERATORS FOR USE IN WASTE LANDFILL INSTALLATIONS; RICE MILLING MACHINES FOR HOUSEHOLD PURPOSES; CONVEYORS, NAMELY, APPARATUS FOR SLUDGE CONVEYANCE IN THE NATURE OF LOADERS FOR INCINERATORS; CONVEYORS, NAMELY, WASTE CONVEYORS FOR USE IN WASTE WATER TREATMENT INSTALLATIONS; MECHANICAL DISCHARGING HOPPERS FOR USE IN WASTE WATER TREATMENT INSTALLATIONS; CAMS BEING MACHINE ELEMENTS IN THE NATURE OF CAMSHAFTS FOR VEHICLE ENGINES (U.S. CLS. 13, 19, 21, 23, 31, 34 AND 35).

CLASS 9—ELECTRICAL AND SCIENTIFIC APPARATUS

FOR WIRELESS AND WIRED TELEMONITORING SYSTEMS FOR PUMPS CONSISTING OF COMPUTER HARDWARE AND COMPUTER SOFTWARE USED TO MONITOR THE STATUS OF MACHINERY; ELECTRIC CONTROL PANELS; SWITCHBOARDS; INTERNET COMMUNICATION EQUIPMENT, NAMELY, COMPUTER HARDWARE AND COMMUNICATION SOFTWARE FOR PROVIDING ACCESS TO THE INTERNET; TRANSMITTERS FOR TELECOMMUNICATION, NAMELY, RADIO AND TELEPHONE TRANSMITTERS; ELECTRICAL CONTROLLERS, NAMELY, ELECTRONIC REMOTE CONTROLLERS OF SIGNALS; RADIOTELEPHONY SETS; COMPUTERS; VENDING MACHINES; ELECTRONIC DISPLAY SCREENS FOR TRACTORS; ELECTRONIC DISPLAY SCREENS FOR AGRICULTURAL MACHINES; BATTERIES FOR AGRICULTURAL MACHINES; GAS FILLING DEVICES, NAMELY, GASOMETER AND GAS METERS; LIQUID FILLING DEVICES, NAMELY, LIQUID LEVEL SENSORS, AUTOMATIC LIQUID-LEVEL CONTROL MACHINES AND INSTRUMENTS; POWDER AND PARTICLE FEEDERS AND GRAVIMETRIC FEEDERS IN THE NATURE OF WEIGHING FEEDERS; HOPPER SCALES; BELT SCALES; CONVEYOR SCALES; PEDOMETERS; WEIGHING FEEDERS; PLATFORM SCALES; EXPLOSION-PROOF SCALES; WASTE WEIGHING SCALES; ELECTRONIC BALANCE SCALES; HOOK SCALES; TRUCK SCALES; WEIGHT SCALES; ELECTRONIC INDICATORS BEING A CONTROL CENTER OF WEIGHING SYSTEM AND FUNCTIONING AS AN AMPLIFIER THAT RECEIVES DATA OUTPUT FROM THE LOAD CELL; TICKET-VENDING MACHINES; RICE TASTE ANALYZERS THAT ANALYZE THE TASTE AND INGREDIENTS OF RICE AND HUSKED RICE BY EXPOSING A SAMPLE TO THE LIGHT; LOAD CELLS, NAMELY, ELECTRICAL TRANSDUCER; COMPUTER AIDED DESIGN APPARATUS, NAMELY, COMPUTERS AND COMPUTER SOFTWARE FOR USE WITH COMPUTER AIDED DESIGN AND COMPUTER HARDWARE; THERMOSTATS; MACHINES FOR QUALITY ASSESSMENT OF FRUITS AND VEGETABLES, NAMELY, INSTRUMENTS FOR MEASURING FRUIT AND VEGETABLE QUALITY PARAMETERS; INCINERATOR COMBUSTION CONTROL DEVICES, NAMELY, ELEC-

TRICAL CONTROLLING DEVICES; ATMOSPHERE CONTROL APPARATUS, NAMELY, CLIMATE CONTROL SYSTEMS CONSISTING OF DIGITAL THERMOSTATS, AND AIR CONDITIONING, HEATING, VENTILATION AND DRYING CONTROL DEVICES (U.S. CLS. 21, 23, 26, 36 AND 38).

CLASS 11—ENVIRONMENTAL CONTROL APPARATUS

FOR SLUDGE INCINERATORS; INCINERATORS; AIR PREHEATERS, NAMELY, HEATING UNITS FOR INCINERATORS, HEATING UNITS FOR ATMOSPHERE CONTROL APPARATUS; HEAT EXCHANGING APPARATUS BEING HEAT EXCHANGERS; HEAT EXCHANGERS FOR CHEMICAL PROCESSING; SLUDGE DRYING APPARATUS, NAMELY, DRYERS USED FOR THE DRYING OF SLUDGE BY STEAM, FIRE, COMPRESSED AIR AND COMPRESSED GASES; APPARATUS FOR DUMPING SLUDGE IN SLUDGE INCINERATORS, NAMELY, SCREW CONVEYORS, BELT CONVEYORS AND SKIP HOISTS; APPARATUS FOR COOLING WASTE GAS DISCHARGED FROM INCINERATORS, NAMELY, COOLING EQUIPMENT THAT COOLS THE WASTE GAS DISCHARGED FROM INCINERATORS BY SPRAYING WATER AND OTHER COOLANTS INTO THE GAS; APPARATUS FOR COLLECTING DUST IN WASTE GAS DISCHARGED FROM INCINERATORS, NAMELY, ELECTRIC DUST COLLECTORS AND BUG COLLECTORS; APPARATUS FOR TREATING WASTE GAS DISCHARGED FROM INCINERATORS, NAMELY, APPARATUS FOR REMOVING SULFUR OXIDES, HYDROCHLORIC ACIDS, DIOXINS AND OTHER HAZARDOUS SUBSTANCES IN THE WASTE GAS; APPARATUS FOR HUMIDIFYING INCINERATED ASH IN INCINERATORS, NAMELY, HUMIDIFIERS; APPARATUS FOR DISPOSING INCINERATED ASH IN INCINERATORS, NAMELY, APPARATUS FOR SOLIDIFYING THE INCINERATED ASH IN GLOBULAR FORM; PLUMBING FITTINGS, NAMELY, VALVES FOR WATER OR GAS PLUMBING; PLUMBING FITTINGS, NAMELY, VALVES FOR PIPELINE; WATER FOUNTAINS; MIST GENERATING APPARATUS IN THE NATURE OF MISTING SYSTEMS FOR OUTDOOR COOLING AND ORNAMENTAL MISTING SYSTEMS; AIR CONDITIONING APPARATUS; INDUSTRIAL AIR PURIFIERS; AIR-HEATERS, NAMELY, APPARATUS FOR HEATING COMBUSTION AIR IN THE INCINERATOR AND APPARATUS FOR HEATING AIR TAKEN INTO OR EXHAUSTED FROM THE AIR CONDITIONER; AIR REHEATERS, NAMELY, APPARATUS FOR REHEATING HEATED COMBUSTION AIR IN THE INCINERATOR AND APPARATUS FOR REHEATING HEATED AIR TAKEN INTO OR EXHAUSTED FROM THE AIR CONDITIONER; INDUSTRIAL WATER PURIFYING APPARATUS, SEWAGE WATER PURIFYING APPARATUS AND WASTE WATER PURIFYING APPARATUS; SEWAGE TREATMENT APPARATUS, NAMELY, SEWAGE TREATMENT PLANTS, THICKENING AND DEWATERING MACHINES FOR USE IN TREATMENT OF SEWAGE, SEWAGE TREATMENT TANKS, SEWAGE AGITATION AND AERATION TANKS, DUST ELIMINATORS, AND SEWAGE TREATMENT UNITS; APPARATUS FOR METHANE FERMENTATIVE TREATMENT OF ORGANIC EFFLUENT, NAMELY, METHANE FERMENTATIVE TREATMENT TANKS FOR USE IN TREATMENT OF LIQUIDS INCLUDING WATER, INDUSTRIAL EFFLUENT AND SEWAGE; APPARATUS FOR HOUSEHOLD PURPOSES, FOR FERMENTATIVE TREATMENT OF ORGANIC EFFLUENT, NAMELY, METHANE FERMENTATIVE TREATMENT TANKS FOR USE IN TREATMENT OF ORGANIC MATERIALS CONTAINED IN THE HOUSE EFFLUENT; APPARATUS FOR HOUSEHOLD PURPOSES, FOR TREATMENT OF EFFLUENT, NAMELY, TREATMENT TANKS FOR USE IN PURIFICATION OF HOUSEHOLD EFFLUENT; WASTE WATER TREATMENT TANKS FOR INDUSTRIAL PURPOSES IN THE NATURE OF WATER PURIFICATION TANKS; SEPTIC TANKS FOR INDUSTRIAL PURPOSES; APPARATUS FOR TREATMENT OF EXCRETA, NAMELY, BIOREACTOR FOR USE IN THE TREATMENT OF WASTE, ENVIRONMENTAL CONTROL APPARATUS IN THE NATURE OF PARTICLE ACTIVATORS FOR USE IN WASTE WATER TREATMENT; WASTE WATER TREATMENT TANKS FOR HOUSEHOLD PURPOSES IN THE NATURE OF WASTE WATER PURIFICATION UNITS; APPARATUS FOR TREATMENT OF DOMESTIC WASTE WATER IN THE NATURE OF WASTE WATER

PURIFICATION UNITS; WASTE WATER PURIFICATION UNITS IN THE NATURE OF DUST COLLECTING APPARATUS FOR USE IN TREATMENT OF WASTE WATER; WASTE WATER PURIFICATION UNITS IN THE NATURE OF DUST ELIMINATORS FOR USE IN WASTE WATER TREATMENT INSTALLATIONS, GRIT LIFTERS FOR USE IN WASTE WATER TREATMENT INSTALLATIONS, GRIT WASHERS FOR USE IN WASTE WATER TREATMENT INSTALLATIONS, GRIT COLLECTORS FOR USE IN WASTE WATER TREATMENT INSTALLATIONS, SCREEN RESIDUE WASHERS FOR USE IN WASTE WATER TREATMENT INSTALLATIONS, SCREEN RESIDUE DEHYDRATORS FOR USE IN WASTE WATER TREATMENT INSTALLATIONS; WASTE WATER TREATMENT APPARATUS IN THE NATURE OF SLUDGE COLLECTORS FOR USE IN WASTE WATER TREATMENT INSTALLATIONS; SCUM REMOVERS IN THE NATURE OF SCUM SEPARATORS AND SCUM SKIMMERS FOR THE CLEANING AND PURIFICATION OF LIQUIDS FOR USE IN WASTE WATER TREATMENT INSTALLATIONS; AIR DIFFUSERS FOR USE IN WASTE WATER TREATMENT INSTALLATIONS; WATER TREATMENT EQUIPMENT, NAMELY, STIRRERS FOR USE IN WASTE WATER TREATMENT INSTALLATIONS; CARRIERS OF MICROORGANISMS FOR USE IN WASTE WATER TREATMENT INSTALLATIONS, NAMELY, GRANULAR SUBSTANCES OR SMALL PIECES OF INORGANIC SUBSTANCES SUCH AS ANTHRACITE AND GRANULAR CERAMIC OR ORGANIC SUBSTANCES SUCH AS POLYETHYLENE AND POLYURETHANE USED AS CARRIERS TO WHICH MICROORGANISMS ARE ATTACHED; WATER TREATMENT EQUIPMENT, NAMELY, FLOCCULATION SETTLING BASINS FOR USE IN WASTE WATER TREATMENT INSTALLATIONS; WATER FILTERS IN THE NATURE OF SAND FILTERS FOR USE IN WASTE WATER TREATMENT INSTALLATIONS; WATER TREATMENT EQUIPMENT, NAMELY, FILTER BASINS FOR USE IN WASTE WATER TREATMENT INSTALLATIONS; WATER FILTERS IN THE NATURE OF OZONE-BIOLOGICAL ACTIVATED CARBON FILTERS FOR USE IN WASTE WATER TREATMENT INSTALLATIONS; WATER FILTERS IN THE NATURE OF STRAINERS BEING FILTERING APPARATUS FOR USE IN WASTE WATER TREATMENT INSTALLATIONS; CHLORINE DISINFECTION APPARATUS FOR USE IN WASTE WATER TREATMENT INSTALLATIONS; OZONE DISINFECTION APPARATUS IN THE NATURE OF OZONE SANITIZERS FOR USE IN WASTE WATER TREATMENT INSTALLATIONS; ULTRAVIOLET DISINFECTION APPARATUS IN THE NATURE OF ULTRAVIOLET STERILIZATION UNITS FOR USE IN WASTE WATER TREATMENT INSTALLATIONS; CHLORINE DIOXIDE DISINFECTION APPARATUS FOR USE IN WASTE WATER TREATMENT INSTALLATIONS; SLUDGE THICKENERS IN THE NATURE OF THICKENING MACHINES FOR THE TREATMENT OF WATER FOR USE IN WASTE WATER TREATMENT INSTALLATIONS; SLUDGE DEHYDRATORS FOR USE IN WASTE WATER TREATMENT INSTALLATIONS; WATER PURIFICATION TANKS IN THE NATURE OF DIGESTION TANK EQUIPMENT FOR USE IN WASTE WATER TREATMENT INSTALLATIONS; DEHYDRATION AND DRYING APPARATUS FOR USE IN WASTE WATER TREATMENT INSTALLATIONS; DEODORIZING UNITS UTILIZING MICROORGANISMS IN THE NATURE OF BIOLOGICAL DEODORIZATION APPARATUS FOR USE IN WASTE WATER TREATMENT INSTALLATIONS; ACTIVATED CARBON DEODORIZING UNITS IN THE NATURE OF BIOLOGICAL DEODORIZATION APPARATUS FOR USE IN WASTE WATER TREATMENT INSTALLATIONS; DEODORIZING UNITS UTILIZING CHEMICAL ACTION OF CHEMICALS IN THE NATURE OF BIOLOGICAL DEODORIZATION APPARATUS FOR USE IN WASTE WATER TREATMENT INSTALLATIONS; SOIL DEODORIZING UNITS IN THE NATURE OF BIOLOGICAL DEODORIZATION APPARATUS FOR USE IN WASTE WATER TREATMENT INSTALLATIONS; WATER PURIFICATION INSTALLATIONS; FILTRATION APPARATUS FOR USE IN WATER PURIFICATION INSTALLATIONS; CHEMICAL PRODUCTION APPARATUS IN THE NATURE OF CHEMICAL STERILIZATION UNITS, SLUDGE CLUMPING UNITS, AND WASHING UNITS FOR WASHING COMPONENTS OF WATER PURIFICATION INSTALLATIONS, FOR USE IN WATER PURIFICATION INSTALLATIONS; CHEMICAL FEEDING APPARATUS FOR USE IN WATER PURIFICATION INSTALLATIONS,

NAMELY, CHEMICALS FEEDING UNITS COMPRISING PRIMARILY OF CHEMICAL STORAGE TANKS AND PUMPS THAT FEED MEASURED AMOUNTS OF CHEMICALS IN THE WATER PURIFICATION INSTALLATION; WASTE LANDFILL INSTALLATIONS, NAMELY, WATER INTAKE UNITS, SEDIMENTATION UNITS, FILTRATION UNITS, TOXICS REMOVAL UNITS, EFFLUENT PURIFICATION UNITS AND DEHYDRATION UNITS, ALL BEING COMPONENTS OF WASTE LANDFILL; TOXICS REMOVAL APPARATUS FOR USE IN WASTE LANDFILL INSTALLATIONS, NAMELY, CALCIUM REMOVAL UNITS, CHROMINANCE CONTROL UNITS, HEAVY METAL REMOVAL UNITS, BORON ADSORPTION UNITS, DIOXIN DECOMPOSITION UNITS AND DESALINATION UNITS; PHOTOCHEMICAL DECOMPOSITION APPARATUS FOR USE IN WASTE LANDFILL INSTALLATIONS, NAMELY, CALCIUM REMOVAL UNITS, CHROMINANCE CONTROL UNITS, HEAVY METAL REMOVAL UNITS, BORON ADSORPTION UNITS, DIOXIN DECOMPOSITION UNITS AND DESALINATION UNITS; DESALINATION UNITS FOR USE IN WASTE LANDFILL INSTALLATIONS; CHELATING ADSORPTION TOWERS FOR USE IN WASTE LANDFILL INSTALLATIONS; CONTACT AERATORS FOR USE IN WASTE LANDFILL INSTALLATIONS; ELECTRIC RICE COOKERS; REFRIGERATING MACHINES, NAMELY, LOW TEMPERATURE STORAGES FOR CEREALS; INDUSTRIAL RICE COOKERS; INDUSTRIAL STIR FRYERS; APPARATUS FOR FERMENTATIVE TREATMENT OF ORGANIC WASTE FOR HOUSEHOLD PURPOSES, NAMELY, APPARATUS THAT FERMENT ORGANIC WASTE BY THE ACTION OF MICROORGANISMS; WASTE PROCESSING MACHINES AND APPARATUS, NAMELY, COMPOSTERS; APPARATUS FOR FERMENTATIVE TREATMENT OF ORGANIC WASTE FOR HOUSEHOLD PURPOSES, NAMELY, APPARATUS THAT FERMENT ORGANIC WASTE BY THE ACTION OF MICROORGANISMS; WASTE PROCESSING MACHINES AND APPARATUS FOR HOUSEHOLD USE, NAMELY, COMPOSTERS; SOIL DISINFECTION MACHINES IN THE NATURE OF ENVIRONMENTAL CONTROL APPARATUS, NAMELY, PARTICLE ACTIVATORS FOR USE IN SOIL REMEDIATION; APPARATUS FOR TREATING WASTE GAS DISCHARGED FROM INCINERATORS, NAMELY, APPARATUS FOR REMOVING SULFUR OXIDES, HYDROCHLORIC ACIDS, DIOXINS AND OTHER HAZARDOUS SUBSTANCE IN THE WASTE GAS; INDUSTRIAL HUMIDIFIERS, NAMELY, APPARATUS FOR HUMIDIFYING INCINERATED ASH IN INCINERATORS (U.S. CLS. 13, 21, 23, 31 AND 34).

CLASS 12—VEHICLES

FOR DRAINAGE PUMP TRUCKS; WATER PUMP TRUCKS; PUMP TRUCKS; FARM TRACTORS; LAWN TRACTORS; MULTIPURPOSE TRANSPORTATION VEHICLES, NAMELY, ALL-TERRAIN VEHICLES; TRANSPORTATION VEHICLES FOR CONSTRUCTION USE, NAMELY, WHEEL LOADERS; LAND VEHICLES FOR TRANSPORTATION OF CROPS OR MATERIALS; FORK LIFT TRUCKS; TRAILERS; ELECTRIC AUTOMOBILES; AUTOMOBILES; CARRIER TRICYCLES; ELECTRIC WHEELED PLATFORMS FOR TRANSPORT PURPOSES; TWO-WHEELED TROLLEYS; ROPEWAYS FOR CARGO AND FREIGHT HANDLING; UNLOADING TIPPLERS FOR TILTING RAILWAY FREIGHT CARS; PUSHER CARS FOR MINING; PULLER CARS FOR MINING; NON-ELECTRIC PRIME MOVERS FOR LAND VEHICLES, NAMELY, ENGINES FOR LAND VEHICLES, NOT INCLUDING THEIR PARTS; MACHINE ELEMENTS FOR LAND VEHICLES, NAMELY, DRIVE SHAFTS, AXLE BEARINGS, AXLES; ANTI-THEFT ALARMS FOR VEHICLES; THREE-WHEELED ELECTRIC VEHICLES; FOUR-WHEELED ELECTRIC VEHICLES; WHEEL-CHAIRS; AC MOTORS AND DC MOTORS FOR LAND VEHICLES, NOT INCLUDING THEIR PARTS; STEERING WHEELS FOR VEHICLES; VEHICLE SEATS; TIRES FOR VEHICLE WHEELS; STRUCTURAL PARTS FOR LAND VEHICLES, NAMELY, CRAWLER TRACKS; STRUCTURAL PARTS FOR LAND VEHICLES, NAMELY, CLUTCHES HOUSING FOR LAND VEHICLES; STRUCTURAL PARTS FOR LAND VEHICLES, NAMELY, AXLE CASES FOR VEHICLES; WHEEL RIMS; DRIVE SHAFTS, AXLES AND SPINDLES FOR LAND VEHICLES; MACHINE ELEMENTS FOR LAND VEHICLES IN THE NATURE OF BEARINGS, NAMELY, WHEEL BEARINGS AND AXLE BEARINGS; MACHINE

ELEMENTS FOR LAND VEHICLES IN THE NATURE OF SHAFT COUPLINGS AND CONNECTORS; MACHINE ELEMENTS FOR LAND VEHICLES IN THE NATURE OF SPEED CHANGE GEARS, NAMELY, GEAR SHIFTS; MACHINE ELEMENTS FOR LAND VEHICLES, NAMELY, TOOTHED WHEELS IN THE NATURE OF GEARS FOR VEHICLES; MACHINE ELEMENTS FOR LAND VEHICLES, NAMELY, SHOCK ABSORBING SPRINGS FOR MOTOR CARS; MACHINE ELEMENTS FOR LAND VEHICLES, NAMELY, SHOCK ABSORBERS FOR AUTOMOBILES; MACHINE ELEMENTS FOR LAND VEHICLES IN THE NATURE OF POWER TRANSMISSION BELTS FOR LAND VEHICLES; POWER TRANSMISSION AND GEARINGS FOR LAND VEHICLES; BRAKES FOR LAND VEHICLES; COUNTER BALANCING WEIGHTS FOR ATTACHMENT TO THE FRONT END OR REAR END OF VEHICLES SUCH AS TRACTORS AND TRANSPORTATION VEHICLES AND MACHINES TO KEEP ANTEROPOSTERIOR WEIGHT BALANCE WHEN THEY ARE EQUIPPED WITH WORKING ATTACHMENTS (U.S. CLS. 19, 21, 23, 31, 35 AND 44).

CLASS 17—RUBBER GOODS

FOR CHEMICAL FIBERS, NAMELY, POTASSIUM TITANATE FIBERS, CALCIUM TITANATE FIBERS, ALKALI METAL TITANATE FIBERS, ALKALI EARTH METAL TITANATE FIBERS, FIBERS OF ALKALI METAL SALT OF TITANIC ACID, AND FIBERS OF ALKALI EARTH METAL SALT OF TITANIC ACID FOR USE IN LININGS AND NOT FOR TEXTILE USE OR SPINNING USE (U.S. CLS. 1, 5, 12, 13, 35 AND 50).

CLASS 35—ADVERTISING AND BUSINESS

FOR WHOLESALE AND RETAIL STORE SERVICES AND ON-LINE WHOLESALE AND RETAIL STORE SERVICES FEATURING WALK-BEHIND TRACTORS FOR AGRICULTURAL USE; WHOLESALE AND RETAIL STORE SERVICES AND ON-LINE WHOLESALE AND RETAIL STORE SERVICES FEATURING COMBINE HARVESTERS; WHOLESALE AND RETAIL STORE SERVICES AND ON-LINE WHOLESALE AND RETAIL STORE SERVICES FEATURING REAPERS AND BINDERS, AND HAY BINDING MACHINES; WHOLESALE AND RETAIL STORE SERVICES AND ON-LINE WHOLESALE AND RETAIL STORE SERVICES FEATURING HARVESTING MACHINES; WHOLESALE AND RETAIL STORE SERVICES AND ON-LINE WHOLESALE AND RETAIL STORE SERVICES FEATURING RICE TRANSPLANTING MACHINES; WHOLESALE AND RETAIL STORE SERVICES AND ON-LINE WHOLESALE AND RETAIL STORE SERVICES FEATURING AGRICULTURAL MACHINES, IMPLEMENTS AND SUPPLIES; WHOLESALE AND RETAIL STORE SERVICES AND ON-LINE WHOLESALE AND RETAIL STORE SERVICES FEATURING CONSTRUCTION MACHINES AND APPARATUS; WHOLESALE AND RETAIL STORE SERVICES AND ON-LINE WHOLESALE AND RETAIL STORE SERVICES FEATURING LOADING-UNLOADING MACHINES AND APPARATUS; WHOLESALE AND RETAIL STORE SERVICES AND ON-LINE WHOLESALE AND RETAIL STORE SERVICES FEATURING CHEMICAL PROCESSING MACHINES AND APPARATUS; WHOLESALE AND RETAIL STORE SERVICES AND ON-LINE WHOLESALE AND RETAIL STORE SERVICES FEATURING FOOD AND BEVERAGE PROCESSING MACHINES AND APPARATUS; WHOLESALE AND RETAIL STORE SERVICES AND ON-LINE WHOLESALE AND RETAIL STORE SERVICES FEATURING PACKAGING AND WRAPPING MACHINES AND APPARATUS; WHOLESALE AND RETAIL STORE SERVICES AND ON-LINE WHOLESALE AND RETAIL STORE SERVICES FEATURING NON-ELECTRIC PRIME MOVERS, NOT FOR LAND VEHICLES; WHOLESALE AND RETAIL STORE SERVICES AND ON-LINE WHOLESALE AND RETAIL STORE SERVICES FEATURING MACHINE ELEMENTS, NOT FOR LAND VEHICLES; WHOLESALE AND RETAIL STORE SERVICES AND ON-LINE WHOLESALE AND RETAIL STORE SERVICES FEATURING LAWNMOWERS; WHOLESALE AND RETAIL STORE SERVICES AND ON-LINE WHOLESALE AND RETAIL STORE SERVICES FEATURING STARTERS FOR MOTORS AND ENGINES; WHOLESALE AND RETAIL STORE SERVICES AND ON-LINE WHOLESALE AND RETAIL STORE SERVICES

FEATURING AC MOTORS AND DC MOTORS, NOT INCLUDING THOSE FOR LAND VEHICLES BUT INCLUDING PARTS FOR ANY AC MOTORS AND DC MOTORS; WHOLESALE AND RETAIL STORE SERVICES AND ON-LINE WHOLESALE AND RETAIL STORE SERVICES FEATURING AC GENERATORS OR ALTERNATORS; WHOLESALE AND RETAIL STORE SERVICES AND ON-LINE WHOLESALE AND RETAIL STORE SERVICES FEATURING DC GENERATORS; WHOLESALE AND RETAIL STORE SERVICES AND ON-LINE WHOLESALE AND RETAIL STORE SERVICES FEATURING SKID-STEER LOADERS (U.S. CLS. 100, 101 AND 102).

SN 77-975,214. TORAY KABUSHIKI KAISHA (TORAY INDUSTRIES, INC.), TOKYO, JAPAN, FILED 2-23-2007.



CLASS 36—INSURANCE AND FINANCIAL

FOR LOANS AND DISCOUNT OF BILLS; LIFE INSURANCE BROKERAGE; LIFE INSURANCE UNDERWRITING; INSURANCE AGENCIES, NAMELY, AGENCIES FOR NON-LIFE INSURANCE; CLAIM ADJUSTMENT IN THE FIELD OF INSURANCE, NAMELY, CLAIM ADJUSTMENT FOR NON-LIFE INSURANCE; NON-LIFE INSURANCE UNDERWRITING, NAMELY, HEALTH, ACCIDENT AND FIRE INSURANCE UNDERWRITING; INSURANCE PREMIUM RATE COMPUTING (U.S. CLS. 100, 101 AND 102).

PRIORITY CLAIMED UNDER SEC. 44(D) ON JAPAN APPLICATION NO. 2007-008190, FILED 2-2-2007, REG. NO. 5102112, DATED 12-28-2007, EXPIRES 12-28-2017.

THE MARK CONSISTS OF TWO LEAVES WITH A LEAF DESIGN WHICH FORMS THE CURVE IN THE LETTER "R".

CLASS 22—CORDAGE AND FIBERS

FOR STAPLE FIBER; CARBON FIBER FOR TEXTILE USE; RAW FIBROUS TEXTILE MATERIALS IN THE FORM OF STAPLE AND FILAMENT; BELTS, NOT OF METAL, FOR WRAPPING AROUND TREE TRUNKS; SYNTHETIC FIBERS (U.S. CLS. 1, 2, 7, 19, 22, 42 AND 50).

CLASS 24—FABRICS

FOR TEXTILE PIECE GOODS, NAMELY, KNITTED, NETTED, WOVEN AND NON-WOVEN NAPKINS, PLACEMATS AND GIFT WRAP; FABRICS MADE WHOLLY OR PARTLY OF POLYPHENYLENE SULPHIDE FIBER; OIL-ABSORPTION CLOTH; SPUN AND BONDED POLYESTER CLOTH FABRICS (U.S. CLS. 42 AND 50).

CLASS 25—CLOTHING

FOR CLOTHING, NAMELY, HATS, PANTS AND SHIRTS (U.S. CLS. 22 AND 39).

GIANCARLO CASTRO, EXAMINING ATTORNEY

CLASS 37—CONSTRUCTION AND REPAIR

FOR REPAIR AND MAINTENANCE OF WALK-BEHIND TRACTORS FOR AGRICULTURAL USE; REPAIR AND MAINTENANCE OF COMBINE HARVESTERS; REPAIR AND MAINTENANCE OF RICE TRANSPLANTING MACHINES; REPAIR AND MAINTENANCE OF AGRICULTURAL MACHINES, IMPLEMENTS AND PARTS THEREFOR; REPAIR AND MAINTENANCE OF CONSTRUCTION MACHINES AND APPARATUS; REPAIR AND MAINTENANCE OF LOADING-UNLOADING MACHINES AND APPARATUS; REPAIR AND MAINTENANCE OF CHEMICAL PROCESSING MACHINES AND APPARATUS; REPAIR AND MAINTENANCE OF FOOD AND BEVERAGE PROCESSING MACHINES AND APPARATUS; REPAIR AND MAINTENANCE OF PACKAGING AND WRAPPING MACHINES AND APPARATUS; REPAIR AND MAINTENANCE OF NON-ELECTRIC MOTORS AND ENGINES, NOT FOR LAND VEHICLES; REPAIR AND MAINTENANCE OF MACHINE ELEMENTS FOR PNEUMATIC AND HYDRAULIC MACHINES, METALWORKING MACHINES, PETROCHEMICAL MACHINES, WASTE COMPACTING MACHINES, WASTE CRUSHING MACHINES, WASTE SMASHING MACHINES, WASTE PROCESSING MACHINES, DEHYDRATION MACHINES, AGRICULTURAL MACHINES, CONSTRUCTION MACHINES, RICE AND BARLEY POLISHING MACHINES, WASHING MACHINES, WAX-POLISHING MACHINES, WELDING MACHINES, CEREAL PROCESSING MACHINES, MIXING MACHINES, COLOR SORTING MACHINES, FILLING MACHINES, PACKAGING AND WRAPPING MACHINES, LOADING-UNLOADING MACHINES AND CHEMICAL PROCESSING MACHINES; REPAIR AND MAINTENANCE OF LAWNMOWERS; REPAIR AND MAINTENANCE OF STARTERS FOR MOTORS AND ENGINES; REPAIR AND MAINTENANCE OF AC MOTORS AND DC MOTORS AND PARTS THEREFOR, NOT INCLUDING THOSE FOR LAND VEHICLES; REPAIR AND MAINTENANCE OF AC GENERATORS AND ALTERNATORS; REPAIR AND MAINTENANCE OF DC GENERATORS; REPAIR AND MAINTENANCE OF SKID-STEER LOADERS (U.S. CLS. 100, 103 AND 106).

JAY BESCH, EXAMINING ATTORNEY

SN 78-798,676. ZYMO RESEARCH CORPORATION, IRVINE, CA. FILED 1-25-2006.



NO CLAIM IS MADE TO THE EXCLUSIVE RIGHT TO USE "RESEARCH", APART FROM THE MARK AS SHOWN.

CLASS 1—CHEMICALS

FOR FULL LINE OF BIOTECHNOLOGY RESEARCH PRODUCTS FOR RESEARCH USE ONLY, NAMELY, REAGENTS FOR NON-MEDICAL PURPOSES, CHEMICALS FOR USE IN INDUSTRY AND SCIENCE, BUFFER SOLUTIONS FOR USE IN ANALYTICAL CHEMISTRY, PROTEINS AND ENZYMES FOR SCIENTIFIC RESEARCH (E.G. ZYMOLYASE, PROTEINASE K, RNASE A) AND PHEROMONES (E.G. YEAST ALPHA-FACTOR AND "A" FACTOR) FOR USE IN EXPRESSION, AMPLIFICATION, MODIFICATION, PURIFICATION, ISOLATION, AND PREPARATION OF NUCLEIC ACIDS AND PROTEINS FOR SCIENTIFIC RESEARCH AND ANALYSIS; BIOLOGICAL SAMPLES, NAMELY, BACTERIA, YEAST, FUNGI, OR MAMMALIAN CELLS (E.G. MAMMALIAN CELL CULTURE LINES OR TISSUE SAMPLES) FOR SCIENTIFIC AND RESEARCH USE; ALL SOLD INDIVIDUALLY AND AS A PART OF KITS (U.S. CLS. 1, 5, 6, 10, 26 AND 46).

FIRST USE 9-1-1994; IN COMMERCE 9-1-1994.

CLASS 9—ELECTRICAL AND SCIENTIFIC APPARATUS

FOR FULL LINE OF BIOTECHNOLOGY RESEARCH PRODUCTS, INSTRUMENTS, AND DEVICES FOR RESEARCH USE ONLY, NAMELY, CHROMATOGRAPHIC COLUMNS, FOR USE IN EXPRESSION, AMPLIFICATION, MODIFICATION, PURIFICATION, ISOLATION, AND PREPARATION OF NUCLEIC ACIDS AND PROTEINS FOR SCIENTIFIC RESEARCH AND ANALYSIS, SOLD INDIVIDUALLY AND AS A PART OF KITS (U.S. CLS. 21, 23, 26, 36 AND 38).

FIRST USE 9-1-1994; IN COMMERCE 9-1-1994.
CHRIS WELLS, EXAMINING ATTORNEY

SN 79-044,199. RHEINMETALL AIR DEFENCE AG, SWITZERLAND, FILED 9-7-2007.

Oerlikon C-RAM

THE MARK CONSISTS OF STANDARD CHARACTERS WITHOUT CLAIM TO ANY PARTICULAR FONT, STYLE, SIZE, OR COLOR.

PRIORITY DATE OF 3-12-2007 IS CLAIMED.

OWNER OF INTERNATIONAL REGISTRATION 0938444 DATED 9-7-2007, EXPIRES 9-7-2017.

OWNER OF U.S. REG. NOS. 3,587,266 AND 3,924,812.

NO CLAIM IS MADE TO THE EXCLUSIVE RIGHT TO USE "C-RAM", APART FROM THE MARK AS SHOWN.

CLASS 9—ELECTRICAL AND SCIENTIFIC APPARATUS

FOR APPARATUS AND INSTRUMENTS FOR MEASUREMENT AND COMMAND TRANSMISSION, NAMELY, COMMUNICATIONS COMPUTERS, ELECTRONIC AND OPTICAL COMMUNICATIONS INSTRUMENTS AND COMPONENTS FOR EVALUATING AND TRANSMITTING CONTROL ORDERS TO FIRE-CONTROL RADARS AND WEAPONS (U.S. CLS. 21, 23, 26, 36 AND 38).

CLASS 13—FIREARMS

FOR CANNONS; WEAPON SYSTEMS, NAMELY, ANTI-AIRCRAFT GUNS WITH INTEGRATED FIRE-CONTROL RADARS (U.S. CLS. 2 AND 9).

ANNE E. GUSTASON, EXAMINING ATTORNEY

SN 79-046,830. RAINBOW S.R.L., ITALY, FILED 6-25-2007.



OWNER OF INTERNATIONAL REGISTRATION 0945033 DATED 6-25-2007, EXPIRES 6-25-2017.

THE MARK CONSISTS OF THE STYLIZED WORD "PIXIE", WITH A FLOWER DESIGN FORMING THE LETTER "X" IN "PIXIE".

CLASS 9—ELECTRICAL AND SCIENTIFIC APPARATUS

FOR VIDEO GAME CARTRIDGES AND CASSETTES, VIDEO GAME DISCS, VIDEO GAME MACHINES FOR USE WITH TELEVISIONS, VIDEO GAME SOFTWARE, CHILDREN'S EDUCATIONAL SOFTWARE, APPARATUS FOR TRANSMITTING AND REPRODUCING SOUND OR IMAGES, AUDIO CASSETTE RECORDERS, AUDIO TAPE RECORDERS, DVD PLAYERS, CALCULATORS, EYEGLASSES AND SUNGLASSES, CASES FOR SPECTACLES, EYE GLASS CHAINS, EYE GLASS CORDS, EYEGLASS FRAMES, BICYCLE HELMETS, WALKIE-TALKIES; MOTION PICTURE FILMS FEATURING ANIMATED CARTOONS (U.S. CLS. 21, 23, 26, 36 AND 38).

CLASS 14—JEWELRY

FOR COSTUME JEWELRY AND JEWELRY, NAMELY, BRACELETS, EARRINGS, EAR PENDANTS, NECKLACES, CHAINS, RINGS, BROOCHES, TIEPINS, TIE BARS, PENDANTS, COLLAR AND BRACELET CHARMS, CUFF LINKS, AND KEY RINGS OF PRECIOUS METAL; HOROLOGICAL AND CHRONOMETRIC INSTRUMENTS, NAMELY, WATCHES, CLOCKS, TABLE CLOCKS, STOPWATCHES, CHRONOMETERS, ALARM WATCHES, DIGITAL WATCHES, AND ANALOGUE WATCHES (U.S. CLS. 2, 27, 28 AND 50).

CLASS 15—MUSICAL INSTRUMENTS

FOR MUSICAL INSTRUMENTS (U.S. CLS. 2, 21 AND 36).

CLASS 16—PAPER GOODS AND PRINTED MATTER

FOR OFFICE REQUISITES, NAMELY, PEN OR PENCIL HOLDERS; PENCILS, PENCIL SHARPENERS, PEN AND PENCIL CASES AND BOXES, COLOUR PENCILS, BALL POINT PENS, FELT PENS; PRINTED MATTER, NAMELY, MAGAZINES FEATURING STORIES, GAMES AND ACTIVITIES BASED ON ANIMATED CARTOONS (U.S. CLS. 2, 5, 22, 23, 29, 37, 38 AND 50).

CLASS 18—LEATHER GOODS

FOR LEATHER AND IMITATION OF LEATHER, TRUNKS AND SUITCASES, UMBRELLAS, BEACH UMBRELLAS, WALKING STICKS, HAVERSACKS; BAGS, NAMELY, SPORT AND TRAVELLING BAGS; GARMENT BAGS FOR TRAVEL, SEA BAGS IN THE NATURE OF DUFFEL BAGS, BRIEFCASES, PURSES, SHOULDER BAGS, CARRY-ON BAGS, TOTE BAGS, BACKPACKS, SCHOOL BAGS, HANDBAGS, SACHEL BAGS, AND WAIST BAGS; WALLETS, WALLETS FOR KEEPING CREDIT CARDS, KEY CASES; LEATHER LEASHES FOR ANIMALS; BEAUTY CASES, NOT FITTED, IN THE NATURE OF COSMETIC CASES SOLD EMPTY (U.S. CLS. 1, 2, 3, 22 AND 41).

CLASS 24—FABRICS

FOR TOWELS; HAND TOWELS; BATH CLOTHS IN THE NATURE OF WASHCLOTHS, TEXTILE NAPKINS, PILLOWCASES (U.S. CLS. 42 AND 50).

CLASS 25—CLOTHING

FOR CLOTHING, NAMELY, SWEATERS, CARDIGANS, SLOPES CLOTHING IN THE NATURE OF PULLOVERS, HALLOWEEN COSTUMES, SUITS, TROUSERS, SHORTS, JUMPERS, RAINCOATS, SUITS AND DRESSES MADE OF LEATHER, STOCKINGS AND SOCKS, GARTER BELTS, OUTERWEAR, NAMELY, WIND-RESISTANT JACKETS, SKI TROUSERS, FUR COATS, OVERCOATS, JACKETS, INFANT WEAR, SKIRTS, DRESSES, UNDERSHIRTS, POLO SHIRTS, SPORT T-SHIRTS, BLOUSES, SHIRT COLLARS, SHIRTS, FOULARDS, BEACHWEAR, SWIMSUITS, BIKINIS, TRACKSUITS, UNDERWEAR, BRAS, BRASSIERES, CORSETS, FOUNDATION GARMENTS, BRIEFS AND BIKINI BRIEFS, VESTS, NIGHTGOWNS, NEGLIGEEES, PYJAMAS, GLOVES, SHAWLS, SCARVES, NECKTIES, BOW TIES, BELTS, HATS AND CAPS, SHOES, BOOTS, LACED BOOTS, LEATHER SHOES, RUBBER SHOES, RAIN SHOES, SPORT SHOES, SANDALS, SLIPPERS, SHOE SOLES; SHOE HEELS IN THE NATURE OF HEEL PIECES FOR SHOES; MOULDED SOLES FOR SHOES (U.S. CLS. 22 AND 39).

CLASS 28—TOYS AND SPORTING GOODS

FOR PLUSH TOYS, RUBBER TOYS, NAMELY, INFLATABLE THIN RUBBER TOYS, RUBBER BALLS, RUBBER CHARACTER TOYS, TOY ANIMALS; WOODEN TOYS, NAMELY, TOY VEHICLES, DOLLS, TOY BUILDING BLOCKS, PLASTIC TOYS, NAMELY, MODEL PLASTIC TOY FIGURINES, PLASTIC CHARACTER TOYS, PLASTIC TOY HOOPS, TOY TRUCKS, AND DOLLS; MUSICAL TOYS, PLAYING BALLS, TOY BUILDING BLOCKS, TOY SCOOTERS, DOLLS, DOLL'S ROOMS, CLOTHES FOR DOLLS, DOMINOES, BACKGAMMON GAMES, DICE, CHESS GAMES, EDUCATIONAL GAMES IN THE NATURE OF BOARD GAMES, CARD GAMES, AND DICE GAMES FOR TEACHING ARITHMETIC, READING SKILLS, LANGUAGES, GEOGRAPHY, SCIENCE, ASTROLOGY, ANATOMY, HISTORY, PHYSICS RULES OF THE ROAD, AND DRAWING, EQUIPMENT SOLD AS A UNIT FOR PLAYING MEMORY GAMES, PUZZLES; PARLOR GAMES, NAMELY, CHECKERS, CHESS, AND SEA BATTLE SIMULATION GAMES; BINGO, PARTY GAMES, NAMELY, GAMES WITH NUMBERED CARDS AND DISKS EXTRACTED ONE AT A TIME, AND GAMES WITH MASTER CHARTS DICE AND CARDS; HANDHELD UNITS FOR PLAYING VIDEO GAMES OTHER THAN THOSE ADAPTED FOR USE WITH AN EXTERNAL DISPLAY SCREEN, NAMELY, SUCH GAMES UNITS WITH ELECTRONIC MAGIC WRITING BOARDS AND SUCH GAME UNITS WITH ELECTRONIC KEYBOARD; GAMES WITH ELECTRONIC VIDEO, NAMELY, HANDHELD UNITS FOR PLAYING VIDEO GAMES OTHER THAN THOSE ADAPTED FOR USE WITH AN EXTERNAL DISPLAY MONITOR, BOARD GAMES WITH ELECTRONIC PENS, PLAYING CARDS; PUPPETS; ROLLER SKATES; RUBBER BALLS; SKATEBOARDS; SOCCER BALLS; TOY FIGURES; MUSIC BOX TOYS; TOY BUCKET AND SHOVEL SETS (U.S. CLS. 22, 23, 38 AND 50).

CLASS 30—STAPLE FOODS

FOR COCOA, SUGAR, RICE, FLOUR, PREPARATIONS MADE FROM CEREALS, NAMELY, BREAKFAST CEREALS, CEREAL BASED SNACK FOODS, ICES, NAMELY, ICE CREAM; HONEY; TREACLE (U.S. CL. 46).

CLASS 32—LIGHT BEVERAGES

FOR MINERAL AND AERATED WATERS; FRUIT DRINKS AND FRUIT JUICES; SYRUPS AND OTHER PREPARATIONS FOR MAKING BEVERAGES, NAMELY, CONCENTRATES, SYRUPS, OR POWDERS USED IN THE PREPARATION OF SOFT DRINKS AND FLAVOURED WATER (U.S. CLS. 45, 46 AND 48).

CLASS 41—EDUCATION AND ENTERTAINMENT

FOR PRODUCTION AND DISTRIBUTION OF MOTION PICTURES IN THE FORM OF SERIAL FILM AND ANIMATED CARTOONS; PRODUCTION OF RADIO PROGRAMS HAVING COMEDIC AND DRAMATIC PERFORMANCES FEATURING THE VOICES OF CARTOON CHARACTERS; PRODUCTION OF TELEVISION PROGRAMS FEATURING ANIMATED CARTOONS; ENTERTAINMENT IN THE NATURE OF VISUAL AND AUDIO PERFORMANCES, NAMELY, ANIMATED CARTOONS (U.S. CLS. 100, 101 AND 107).
KEVIN CORWIN, EXAMINING ATTORNEY

SN 79-058,144. PLUS LICENS AB, SWEDEN, FILED 10-25-2007.

MOSHIMOSHIKAWAI

THE MARK CONSISTS OF STANDARD CHARACTERS WITHOUT CLAIM TO ANY PARTICULAR FONT, STYLE, SIZE, OR COLOR.

PRIORITY DATE OF 4-25-2007 IS CLAIMED.
OWNER OF INTERNATIONAL REGISTRATION 0975527 DATED 10-25-2007, EXPIRES 10-25-2017.

THE ENGLISH TRANSLATION OF "MOSHIMOSHIKAWAI" IN THE MARK IS "HELLO CUTIE".

CLASS 3—COSMETICS AND CLEANING PREPARATIONS

FOR CLEANING, POLISHING, SCOURING AND ABRASIVE PREPARATIONS; PERFUMERY, ESSENTIAL OILS, COSMETICS, HAIR LOTIONS; DENTIFRICES; NON-MEDICATED TOILETRIES; PRODUCTS AND PREPARATIONS FOR THE CARE AND CLEANSING OF HAIR AND SKIN, NAMELY, SOAPS, SHOWER GELS, SHAMPOOS, HAIR CONDITIONERS; ADHESIVES FOR COSMETIC PURPOSES; AFTER-SHAVE LOTIONS; ANTIPERSPIRANTS; AROMATICS IN THE NATURE OF FRAGRANCES; BATH SALTS; COSMETIC PREPARATIONS FOR BATHS, NAMELY, BATH BEADS AND BATH FOAMS; BEAUTY MASKS; COLOR-REMOVING PREPARATIONS, NAMELY, HAIR COLOR REMOVERS; COSMETICS FOR ANIMALS; COTTON STICKS FOR COSMETIC PURPOSES; COTTON WOOL FOR COSMETIC PURPOSES; COSMETIC CREAMS; CREAMS FOR LEATHER; DENTURE CLEANING PREPARATIONS IN THE NATURE OF DENTURE POLISHES; PREPARATIONS FOR CLEANING DENTURES; PERSONAL DEODORANTS; LAUNDRY DETERGENTS; EAU DE COLOGNE; TOILET WATER; HAIR CREAM, HAIR GEL, AND HAIR MOISTENING PREPARATIONS, NAMELY, HAIR MOISTURIZERS; PERFUMES; LIPSTICKS; SKIN AND FACE CREAMS AND LOTIONS; FALSE NAILS; NAIL POLISHES AND VARNISHES AND THINNERS THEREFORE; SUN BLOCKS FOR COSMETIC PURPOSES; FOOD FLAVORINGS FOR CAKE, BEING ESSENTIAL OILS; CLEANSING MILK FOR TOILET PURPOSES; EYEBROW COSMETICS; EYEBROW PENCILS; FABRIC SOFTENERS FOR LAUNDRY USE; FALSE EYELASHES; HAIR DYES; HAIR SPRAY; HAIR WAVING PREPARATIONS; LOTIONS FOR COSMETIC PURPOSES; MAKE-UP; MAKE-UP POWDER; MAKE-UP PREPARATIONS; MAKE-UP REMOVING PREPARATIONS; MASCARA; NAIL CARE PREPARATIONS; COSMETIC PENCILS; POMADES FOR COSMETIC PURPOSES; FRAGRANCES IN THE NATURE OF POTPOURRIS; PUMICE STONE FOR PERSONAL USE; SCENTED WOOD; SHAMPOOS FOR PETS; SHOE CREAM; SHOE POLISH; SHOE WAX; SUN-TANNING PREPARATIONS; TISSUES IMPREGNATED WITH COSMETIC LOTIONS; VARNISH-REMOVING PREPARATIONS; DEPILATORY WAX; WAXES FOR LEATHER; DEPILATORY PREPARATIONS; INCENSE STICKS, NAMELY, JOSS STICKS; FRAGRANCES; DEODORANTS IN THE NATURE OF ANTIPERSPIRANTS (U.S. CLS. 1, 4, 6, 50, 51 AND 52).

CLASS 5—PHARMACEUTICALS

FOR SANITARY PREPARATIONS FOR MEDICAL USE; FOOD FOR BABIES; MEDICAL PLASTERS AND DRESSINGS; ABSORBENT COTTON FOR MEDICAL PURPOSES; ABSORBENT WADDING FOR MEDICAL PURPOSES; ADHESIVE PLASTER FOR MEDICAL PURPOSES; ADHESIVE TAPES FOR MEDICAL PURPOSES; AIR FRESHENING PREPARATIONS; AIR PURIFYING PREPARATIONS; ANIMAL WASHES FOR MEDICAL PURPOSES; COTTON IMPREGNATED WITH ANTISEPTIC; ANTISEPTICS; HYGIENIC BANDAGES FOR SKIN WOUNDS; MENSTRUATION BANDAGES; BANDAGES FOR DRESSINGS; THERAPEUTIC PREPARATIONS FOR THE BATH, NAMELY, MEDICATED BATH SALTS; BREAST-NURSING PADS; CHEWING GUM FOR MEDICAL PURPOSES; CONTACT LENS DISINFECTING, RINSING AND CLEANING PREPARATIONS; CONTACT LENS SOLUTIONS AND LUBRICANTS IN THE NATURE OF WETTING SOLUTION; COM PADS, NAMELY, COM RINGS FOR THE FEET; PHARMACEUTICAL PREPARATIONS FOR TREATING DANDRUFF; DOG LOTIONS FOR MEDICAL PURPOSES; DOG WASHES FOR MEDICAL PURPOSES; EYE-WASHES; FIRST-AID KITS, FILLED; REMEDIES FOR FOOT PERSPIRATION, NAMELY, MEDICATED FOOT POWDER; GAUZE FOR DRESSINGS; MENSTRUATION KNICKERS; SANITARY KNICKERS; TISSUES IMPREGNATED WITH PHARMACEUTICAL LOTIONS; LOTIONS FOR PHARMACEUTICAL PURPOSES; LOTIONS FOR VETERINARY PURPOSES; LOZENGES FOR MEDICAL PURPOSES; MEDICINAL HERBS; MEDICINAL OILS, NAMELY, CASTOR OILS; MEDICINAL TEA; MENSTRUATION

TAMPONS; OINTMENTS FOR PHARMACEUTICAL PURPOSES, NAMELY, ANTIBIOTIC OINTMENTS; MOUTHWASHES FOR PHARMACEUTICAL PURPOSES, NAMELY, MEDICATED MOUTHWASH; SANITARY PANTIES; SANITARY NAPKINS; SANITARY PADS; SANITARY PANTS; PANTY LINERS; REMEDIES FOR PERSPIRATION, NAMELY, MEDICATED BODY POWDER; SANITARY TOWELS; MEDICATED SUNBURN OINTMENTS; VITAMIN PREPARATIONS; MEDICATED SUN CARE PREPARATIONS, NAMELY, SUN BLOCKS FOR MEDICAL PURPOSES; HERB TEAS FOR MEDICAL PURPOSES (U.S. CLS. 6, 18, 44, 46, 51 AND 52).

CLASS 9—ELECTRICAL AND SCIENTIFIC APPARATUS

FOR BLANK MAGNETIC DATA CARRIERS AND PRE-RECORDED MAGNETIC DATA CARRIERS FEATURING AUDIO AND VIDEO RECORDINGS AND INTERACTIVE GAMES FEATURING CARTOON CHARACTERS; RECORDING DISCS, NAMELY, BLANK COMPACT DISCS; CALCULATING MACHINES; DATA PROCESSORS AND COMPUTERS; ABACUSES; AUDIO-VISUAL TEACHING APPARATUS, NAMELY, AUDIO AND VIDEO RECORDINGS FEATURING CARTOON CHARACTERS; BATTERIES; BATTERY BOXES; BATTERY CHARGERS; BINOCULARS; CALCULATORS; CAMERAS; CINEMATOGRAPHIC CAMERAS; LENSES FOR CAMERAS; AUDIO AND VIDEO TAPES, AND DISCS, NAMELY, AUDIO AND VIDEO TAPES AND AUDIO AND VIDEO RECORDINGS IN THE FORM OF DISCS, DVDS, DVD-ROM, CD-ROM, COMPACT DISCS, LASER DISCS, FLOPPY DISCS, HARD DISCS, OPTICAL DISKS, PRE-RECORDED MAGNETIC DATA CARRIERS, PHONOGRAPH RECORDS, MAGNETIC AND DIGITAL TAPES, WITH RECORDED ANIMATED CARTOONS; EYEGLOSS CHAINS; EXPOSED CINEMATOGRAPHIC FILM; TIME RECORDING DEVICE, NAMELY, TIME CLOCKS; COMPACT DISC PLAYERS; COMPACT DISCS FEATURING AUDIO AND VIDEO RECORDINGS AND INTERACTIVE GAMES FEATURING CARTOON CHARACTERS; READ-ONLY MEMORY COMPACT DISCS FEATURING AUDIO AND VIDEO RECORDINGS AND INTERACTIVE GAMES FEATURING CARTOON CHARACTERS; COMPUTER OPERATING PROGRAMS, RECORDED; COMPUTER PROGRAMS USED FOR EDUCATION AND ENTERTAINMENT, FEATURING CARTOON CHARACTERS; RECORDED COMPUTER SOFTWARE USED FOR EDUCATION AND ENTERTAINMENT FEATURING CARTOON CHARACTERS; COMPUTER; DATA PROCESSING APPARATUS, NAMELY, DATA PROCESSORS; ELECTRIC DOOR BELLS; ELECTRONIC POCKET TRANSLATORS; EXPOSED CAMERA FILMS; FLASHLIGHTS; FRAMES FOR PHOTOGRAPHIC TRANSPARENCIES IN THE NATURE OF SLIDE FILM MOUNTS; ELECTRONIC AMUSEMENT APPARATUS FOR USE WITH TELEVISION RECEIVERS ONLY, NAMELY, COMPUTER GAME HARDWARE AND PERIPHERALS; HAIR-CURLERS, ELECTRICALLY HEATED; MAGNETS; NEON SIGNS; NOTEBOOK COMPUTERS; PHONOGRAPH RECORDS FEATURING MUSIC AND CHILDREN STORIES; PHOTOCOPIERS; RADIOS; RECORD PLAYERS; MEASURING INSTRUMENTS IN THE NATURE OF GRADUATED RULERS; SCALES; ELECTRIC SOCKETS, ELECTRIC PLUGS AND OTHER CONTACTS IN THE NATURE OF ELECTRICAL CORDS; SOUND RECORDING APPARATUS; SOUND RECORDING DISCS IN THE NATURE OF COMPACT DISCS FEATURING MUSIC AND CHILDREN STORIES; SOUND REPRODUCTION APPARATUS; SOUND TRANSMITTING APPARATUS; SPECTACLE CASES; SPECTACLE FRAMES; SPECTACLE GLASSES; SPECTACLES; SUNGLASSES; SWIMMING BELTS, NAMELY, WEIGHT BELTS FOR DIVERS; SWIMMING JACKETS, NAMELY, LIFE JACKETS; ELECTRIC SWITCHES; TAPE RECORDERS; TELEPHONES APPARATUS, RECEIVERS, TRANSMITTERS, AND WIRES; TELESCOPES; TELEVISIONS; TELEVISION APPARATUS FOR PROJECTION PURPOSES; TEMPERATURE INDICATORS; ELECTRIC THERMOMETERS; BLANK VIDEO CASSETTES; VIDEO GAME CARTRIDGES; VIDEO RECORDINGS IN THE NATURE OF MAGNETIC DATA CARRIER FEATURING VIDEO GAMES; PRE-RECORDED VIDEOTAPES FEATURING AUDIO AND VIDEO RECORDINGS AND INTERACTIVE GAMES FEATURING CARTOON CHARACTERS; VIDEO SCREENS; WORD PROCESSORS; VIDEO COMPACT DISCS FEATURING AUDIO AND VIDEO RECORDINGS

AND INTERACTIVE GAMES FEATURING CARTOON CHARACTERS; DVD-DISCS FEATURING AUDIO AND VIDEO RECORDINGS AND INTERACTIVE GAMES FEATURING CARTOON CHARACTERS; VIDEO COMPACT DISCS FEATURING AUDIO AND VIDEO RECORDINGS AND INTERACTIVE GAMES FEATURING CARTOON CHARACTERS AND DIGITAL VERSATILE (VIDEO) DISC PLAYERS; KARAOKE MACHINES, NAMELY, AUDIO COMPONENTS FOR USE IN KARAOKE, NAMELY, COMPACT DISC PLAYERS, AUDIO AMPLIFIERS, AUDIO MIXERS, MICROPHONES, AUDIO SPEAKERS AND CABLE FOR USE WITH AUDIO COMPONENTS; HOLDERS, CARRIERS, CASES FOR AUDIO AND VIDEO CASSETTES, COMPACT DISCS; MOUSE PADS; TELEPHONES, WIRELESS TELEPHONES, MOBILE TELEPHONES; MOBILE PHONE CASES OR CASINGS; PAGERS; PAGER CASES OR CASING; BAGS, COVERINGS, CONTAINERS, CARRIERS AND HOLDERS FOR MOBILE TELEPHONES AND PAGERS; HEADPHONES; EARPHONES AND MICROPHONES/SPEAKER-PHONES FOR USE WITH MOBILE TELEPHONES; MOBILE PHONES; VIDEO GAME MACHINES FOR USE WITH TELEVISIONS; ELECTRONIC AGENDAS; ELECTRIC ALARM BELLS; BURGLAR ALARMS; BAROMETERS; ELECTRIC BUZZERS. COMPUTER CENTRAL PROCESSING UNITS; COMPUTER KEYBOARDS; COMPUTER MEMORIES; COMPUTER PERIPHERAL DEVICES; BLANK OPTICAL DATA CARRIERS AND PRERECORDED OPTICAL DATA CARRIERS FEATURING AUDIO AND VIDEO RECORDINGS AND INTERACTIVE GAMES FEATURING CARTOON CHARACTERS; BLANK OPTICAL DISCS AND PRE-RECORDED OPTICAL DISCS FEATURING AUDIO AND VIDEO RECORDINGS AND INTERACTIVE GAMES FEATURING CARTOON CHARACTERS; BLANK MAGNETIC DISKS AND PRE-RECORDED MAGNETIC DISKS FEATURING AUDIO AND VIDEO RECORDINGS AND INTERACTIVE GAMES FEATURING CARTOON CHARACTERS; ELECTRONIC NOTICE BOARDS; VISUAL DISPLAY UNITS IN THE NATURE OF ELECTRONIC PENS; EYEGLASS CORDS; PROTECTIVE EYEPIECES; EYE SHADES FOR PROTECTIVE PURPOSES; PHOTOGRAPHIC FILTERS; FLAT IRONS, ELECTRIC; FLOATS FOR BATHING AND SWIMMING, NAMELY, SWIM FLOATS FOR SAFETY PURPOSES; HAND-HELD PORTABLE TWO WAY RADIO TRANSCIVER; LENS HOODS; MAGNETIC TAPE UNITS FOR COMPUTERS; BLANK MAGNETIC TAPES FOR TAPE RECORDERS AND PRE-RECORDED MAGNETIC TAPES FOR TAPE RECORDERS FEATURING AUDIO AND VIDEO RECORDINGS AND INTERACTIVE GAMES FEATURING CARTOON CHARACTERS; MEASURING SPOONS; MICROPROCESSORS; COMPUTER HARDWARE MONITORS; DATA PROCESSING EQUIPMENT, NAMELY, COMPUTER MOUSE; PHOTOGRAPHIC SLIDES; BLANK SOUND RECORDING STRIPS; TELECOMMUNICATION TRANSMITTERS; VIDEO TELEPHONES; VIDEO RECORDERS; SOUND ALARMS, NAMELY, WHISTLE ALARMS; FLOATING DEVICES FOR SWIMMING, NAMELY, SWIM FLOATS FOR SAFETY PURPOSES; EAR PLUGS FOR SLEEPING; EAR PLUGS FOR DIVERS; EGG TIMERS; GOGGLES FOR SPORTS; PROTECTIVE HELMETS FOR SPORTS; COMPUTER GAME PROGRAMS; DOWNLOADABLE ELECTRONIC PUBLICATIONS IN THE NATURE OF BOOKS, MAGAZINES AND MANUALS IN THE NATURE OF PAMPHLETS, BROCHURES AND BOOKLETS, FEATURING CARTOON CHARACTERS AND ANIMATED CARTOONS, STORIES, GAMES, COMPETITIONS AND QUIZZES IN THE FIELD OF CARTOON ENTERTAINMENT, AND DOWNLOADABLE ELECTRONIC PUBLICATIONS, NAMELY, ELECTRONIC COLORING BOOKS AND POSTERS; DOWNLOADABLE COMPUTER SOFTWARE FEATURING INTERACTIVE GAMES, IMAGES, ANIMATED CHARACTERS, SCREEN SAVERS, AND MOBILE PHONE RING TONES ACCESSED VIA THE INTERNET AND WIRELESS DEVICES; PERSONAL STEREOs; WRIST RESTS FOR USE WITH COMPUTERS; STRAPS FOR PORTABLE TELEPHONES; STANDS FOR PORTABLE TELEPHONES; ANTENNA CAPS FOR PORTABLE PHONES; ELECTRONIC CIRCUITS AND CD-ROMS FEATURING SOFTWARE WHICH ENABLE THE RECORDING OF AUTOMATIC PROGRAMMED PLAYING FOR THE USE WITH ELECTRONIC MUSICAL INSTRUMENTS; CONTAINERS FOR CONTACT LENSES (U.S. CLS. 21, 23, 26, 36 AND 38).

CLASS 14—JEWELRY

FOR JEWELLERY; IMITATION JEWELLERY AND ORNAMENTS OF PRECIOUS METAL; PRECIOUS STONES; HOROLOGICAL AND CHRONOMETRIC INSTRUMENTS; BROOCHES; WATCH CHAINS; CHARMS; COLLECTIBLE COINS; COMMEMORATIVE TOKENS; CUFFLINKS; EARRINGS; GOLD THREAD; JEWELLERY CASES; NECKLACES; JEWELLERY PINS; JEWELLERY, NAMELY, RINGS; STATUES AND STATUETTES OF PRECIOUS METAL; TIE CLIPS; WATCH STRAPS, WATCH BANDS, WATCH CHAINS; WATCH CASES; STOP WATCHES; TIE PINS; MEDALS; KEY RINGS OF PRECIOUS METAL, TRINKETS IN THE NATURE OF RINGS, AND WATCH FOBS; KEY CHAINS AND KEY CASES/CARRIERS OF PRECIOUS METAL AND/OR PRECIOUS STONES; PENDANTS; BADGES OF PRECIOUS METAL; JEWELLERY, NAMELY, BRACELETS; ELECTRIC CLOCKS AND WATCHES; SUN DIALS; DIAMONDS; UNMANUFACTURED AND PROCESSED OR WORKED GOLD; UNMANUFACTURED AND PROCESSED OR WORKED SILVER; COSTUME JEWELLERY; SEMI-PRECIOUS STONES; WORKS OF ART OF PRECIOUS METAL; ALARM CLOCKS; CHENILLE CUFF LINKS; JEWELLERY AND ORNAMENTS OF PRECIOUS METAL FOR MOBILE PHONES (U.S. CLS. 2, 27, 28 AND 50).

CLASS 16—PAPER GOODS AND PRINTED MATTER

FOR BOOKBINDING MATERIALS; PHOTOGRAPHS; STATIONERY; ADHESIVES FOR STATIONERY OR HOUSEHOLD PURPOSES; PAINT BRUSHES; TYPEWRITERS AND OFFICE REQUISITES, NAMELY, STAPLERS; PLASTIC MATERIALS FOR PACKAGING, NAMELY, BUBBLE PACKS; PRINTERS' TYPES; PRINTING BLOCKS; CALENDARS; BOOKS, NAMELY, STORY BOOKS, CHILDREN'S ACTIVITY BOOKS, STICKER BOOKS, PICTURE BOOKS, PUZZLE BOOKS, CHILDREN'S NOVELTY BOOKS, POP-UP BOOKS; POSTCARDS; POSTERS; PRINTED PUBLICATIONS, NAMELY, MAGAZINES, MANUALS, PAMPHLETS, BROCHURES AND BOOKLETS FEATURING CARTOON CHARACTERS; GREETING CARDS; WRITING INSTRUMENTS; RUBBER STAMPS; INK STAMPS AND SEALS FOR OFFICES; STAMP PADS; STAMP INK PADS; PHOTO ALBUMS; PICTURE FRAMING MAT BOARDS; PICTURES OR PHOTOGRAPHS; PAINTERS' EASELS; OIL BLOTTING PAPER FOR SKINS; PHOTOGRAPH STANDS; FACIAL TISSUES; TOILET PAPER; NAPKINS OF PAPER FOR REMOVING MAKE UP; PAPER TOWELS; PLACE MATS AND COASTERS OF PAPER OR CARDBOARD; PACKING PAPER, WRAPPING PAPER AND PACKAGING MATERIALS, NAMELY, GIFT PAPER; GRAPHIC ART REPRODUCTIONS; PORTRAITS; LITHOGRAPHS; PENS, PENCILS, FOUNTAIN PENS, BALL PENS; PEN NIBS; PEN HOLDERS; PENCIL HOLDERS; INK REFILLS FOR PENS AND WRITING INSTRUMENTS; PENCIL LEADS; COLOR PENCILS; CRAYONS; PEN AND PENCIL CASES; PENCIL SHARPENERS; PENCIL SHARPENING MACHINES; PAPER CLIPS; PAPER WEIGHTS; PAPER PINS; PASTELS; PASTES AND GLUES FOR STATIONERY AND HOUSEHOLD PURPOSES; PAPIER MACHE; LETTER TRAYS AND RACKS; LETTER HOLDERS; LETTER OPENERS; ADHESIVE TAPES FOR STATIONERY OR HOUSEHOLD PURPOSES AND ADHESIVE TAPE DISPENSERS; DRAWING MATERIALS, NAMELY, DRAWING BOARDS, PENS AND INSTRUMENTS; DRAWING SETS COMPRISED OF PENS, PENCILS, AND DRAWING PAPER; STAMP AND COIN ALBUMS; PAPER BAGS FOR PACKAGING AND ENVELOPES; BLOTTERS; BOOKENDS; BOOKMARKS; DESK-MOUNTED CABINETS FOR STATIONERY; CANVAS FOR PAINTING; NOTE BOOKS; DIARIES; CARD FILES, WRITING PADS, MEMO PADS, WRITING PAPER; DRAWING PAPER; WRITING CASES IN THE NATURE OF PEN AND PENCIL CASES; CHALKS; BLACKBOARDS; POSTER BOARDS; PASSPORT HOLDERS; CHEQUE BOOKS HOLDERS; ELASTIC BANDS FOR OFFICES; PICTURES; STENCILS, ERASING PRODUCTS, NAMELY, ERASER DUSTING BRUSHES, ERASERS; ELECTRIC LETTER OPENERS; SHEET MUSIC; WIPE-OFF BOARDS; PARTY ORNAMENTS MADE OF PAPER AND/OR CARDBOARD; TISSUE PAPER; PAPER NAPKINS; COLORING BOOKS; BINDER PAPER; POCKET NOTEBOOKS; FELT TIPPED PENS; BLACK LEAD PENCIL SETS; COLOR

PENCIL SETS; RULERS, NAMELY, DRAFTING RULERS, DRAWING RULERS AND UNGRADUATED RULERS; WRITING MATS IN THE NATURE OF WRITING TABLETS; AUTOGRAPH BOOKS; BINDER CLIPS; STAPLERS; TAPE CUTTERS; CAUTION SIGNS, NAMELY, PRINTED PAPER SIGNS; PAPER SHREDDERS; PLASTIC COATING MACHINES, NAMELY, LAMINATING MACHINES FOR HOME AND OFFICE USE; ELECTRIC HEAT-SEALING PROTECTIVE WRAPPING MOUNTING APPARATUS FOR DOCUMENTS AND PHOTOGRAPHS, NAMELY, LAMINATING MACHINES FOR HOME AND OFFICE USE; DESKTOP BUSINESS CARD HOLDERS; DECORATIONS OF PAPER FOR LUNCH BOXES OR FOODSTUFFS; ALBUMS, NAMELY, DECALS AND STICKERS; BABIES' NAPKINS OF PAPER AND CELLULOSE WIPES; BAGS IN THE NATURE OF ENVELOPES AND POUCHES OF PAPER OR PLASTICS FOR PACKAGING; LOOSE-LEAF BINDERS; BOXES OF CARDBOARD OR PAPER; NOTE CARDS; HOLDERS AND CASES FOR STAMPS AND SEALS; COMIC BOOKS; COMPASSES FOR DRAWING; PAPER TAPES AND CARDS FOR THE RECORDAL OF COMPUTER PROGRAMMES; COPYING PAPER; DOCUMENT FILES; OFFICE REQUISITES, NAMELY, FINGER-STALLS; PAPER FLAGS; STATIONERY FOLDERS; FOLDERS FOR PAPERS; GUMMED TAPE FOR STATIONERY OR HOUSEHOLD USE; HANDKERCHIEFS OF PAPER; INDEX CARDS; INKING RIBBONS; PAPER FILE JACKETS; PAPER LABELS; MAPS; MUSICAL GREETING CARDS; DESK PADS. PAINT BOXES FOR USE IN SCHOOL; PAPER SHREDDERS FOR OFFICE USE; PENCIL LEAD HOLDERS; POSTAGE STAMPS; STICKERS; TABLE NAPKINS OF PAPER; PRINTED TICKETS; TYPEWRITER RIBBONS; ELECTRIC OR NON-ELECTRIC TYPEWRITERS; FOOD WRAPPERS; WRITING BRUSHES; WRITING CHALK; WRITING TABLETS; BOOK COVERS; COVERS OF PAPER FOR FLOWER POTS; PAPER CUTTERS; BIBS OF PAPER; BAGS FOR MICROWAVE COOKING; PAPER COFFEE FILTERS; BOOKLETS FEATURING ANIMATED CARTOONS IN THE FIELD OF STORIES BASED ON BOOK CHARACTERS; EMBROIDERY DESIGNS PATTERNS; LETTER OPENERS, NAMELY, PAPER KNIVES; TABLE CLOTHS OF PAPER; TABLE LINEN OF PAPER; SIGNBOARDS OF PAPER OR CARDBOARD; TAGS FOR INDEX CARDS; FACIAL BLOTTING PAPERS; STICKERS FOR PORTABLE TELEPHONE; FRAMES FOR PHOTOGRAPHS; LETTER RACKS (U.S. CLS. 2, 5, 22, 23, 29, 37, 38 AND 50).

CLASS 18—LEATHER GOODS

FOR ANIMAL SKINS AND HIDES; TRUNKS AND TRAVELLING BAGS; UMBRELLAS, PARASOLS AND WALKING STICKS; WHIPS, HARNESS AND SADDLERY; BAGS, NAMELY, TRUNKS, TOTE BAGS, CLUTCH BAGS, SHOULDER BAGS, MESSENGER BAGS, TROLLEY BAGS, GYM BAGS, WAIST BAGS, SHOE BAGS AND NURSERY BAGS; PURSES AND WALLETS; LEATHER POUCHES; ATTACHÉ CASES; BACKPACKS; GARMENT BAGS; SHOPPING BAGS OF LEATHER, IMITATIONS OF LEATHER, TEXTILE FABRIC, AND NYLON; BANDS OF LEATHER; LEATHER SHOULDER BELTS; BUSINESS CARD CASES; COLLARS FOR ANIMALS OR PETS; KEY CASES; VANITY CASES SOLD EMPTY; MUZZLES; SCHOOL SATCHELS; LEATHER STRAPS; SUITCASE HANDLES; SUITCASES; TRAVELLING SETS COMPRISED OF SUITCASES; UMBRELLA COVERS; UMBRELLA HANDLES; WALKING STICK SEATS; BEACH BAGS; BRIEFCASES; BOXES AND CASES, OF LEATHER AND LEATHER BOARD; HANDBAGS; MOUNTAINEERING STICKS; MUSIC CASES IN THE NATURE OF CARRYING CASES; NET BAGS FOR SHOPPING IN THE NATURE OF MESH SHOPPING BAGS; RUCKSACKS; SCHOOL BAGS; TOOL BAGS OF LEATHER AND IMITATIONS OF LEATHER SOLD EMPTY; VALISES; HUNTERS' GAME BAGS; BAGS IN THE NATURE OF ENVELOPES AND POUCHES OF LEATHER FOR PACKAGING; HANDBAG FRAMES; SLING BAGS FOR CARRYING INFANTS; WHEELED SHOPPING BAGS; TRUNKS, AND BAGS OF PAPER; TRUNKS, SHOPPING BAGS AND CARRYING CASES OF TEXTILE FABRIC; TRUNKS OF NYLON AND PLASTICS (U.S. CLS. 1, 2, 3, 22 AND 41).

CLASS 20—FURNITURE AND ARTICLES NOT OTHERWISE CLASSIFIED

FOR FURNITURE, MIRRORS, PICTURE FRAMES; AIR CUSHIONS, AIR MATTRESSES, AND AIR PILLOWS NOT FOR MEDICAL PURPOSES; SLEEPING BAGS; BEAD CURTAINS FOR DECORATION; BEDS FOR HOUSEHOLD PETS; BINS, NOT OF METAL; BOTTLE CLOSURES, NOT OF METAL; BOTTLE RACKS; CORKS FOR BOTTLES; FURNITURE CHESTS; WIND CHIMES; NON-METAL CLOTHES HOOKS; COAT HANGERS; COAT STANDS; PLASTIC STORAGE CONTAINERS FOR COMMERCIAL OR INDUSTRIAL USE; REUSABLE PLASTIC CONTAINER FOR TRANSPORTATION OF MERCHANDISE OR MATERIALS; CURTAIN HOLDERS, NAMELY, CURTAIN RINGS AND RODS; CURTAIN HOOKS; CURTAIN RAILS; CURTAIN RINGS; CURTAIN RODS; CURTAIN ROLLERS; CURTAIN TIE-BACKS; CUSHIONS; FIXED NON-METALLIC TOWEL DISPENSERS; PET KENNELS; EMBROIDERY FRAMES; NON-ELECTRIC FANS FOR PERSONAL USE; STATUES OF WOOD, WAX, PLASTER OR PLASTIC; FIRE SCREENS FOR DOMESTIC USE; FLOWER-POT PEDESTALS; FLOWER-STANDS; HAT STANDS; HIGH CHAIRS FOR BABIES; HOUSE NUMBERS, NOT OF METAL, NON LUMINOUS; NESTING BOXES FOR PETS; IDENTITY PLATES, NOT OF METAL; INDEX CABINETS; INFANT WALKERS; INFLATABLE PUBLICITY OBJECTS; LETTER BOXES NOT OF METAL; MAGAZINE RACKS; MATTRESSES; CONTAINERS OF PLASTIC FOR PACKAGING PURPOSES; PILLOWS; REGISTRATION PLATES, NAMELY, NOVELTY LICENSE PLATES NOT OF METAL; WOOD SIGNBOARDS; WOOD TOOL HANDLES; COMPUTER KEYBOARD TRAYS; WICKERWORK, NAMELY, WICKER FURNITURE; INFLATABLE HEADRESTS NOT FOR MEDICAL USE; DECORATIONS OF PLASTICS FOR FOODSTUFFS; DOORSTOPS OF WOOD; ARMCHAIRS; BAKER'S BREAD BASKETS, NOT OF METAL; BEDS; FURNITURE, NAMELY, BENCHES; BOXES OF WOOD OR PLASTIC; DISPLAY CASES OF WOOD OR PLASTIC; CHAIRS; CHESTS FOR TOYS; CORKS; BAMBOO CURTAINS; DECK CHAIRS; DESKS; FURNITURE, NAMELY, DINNER WAGONS; DRINKING STRAWS; FURNITURE IN THE NATURE OF HEAD-RESTS FOR CHAIRS; KEY CABINETS FEATURING A KEYBOARD FOR HANGING KEYS; LIBRARY SHELVES; NON-ELECTRIC LOCKS, NOT OF METAL; COAT RACKS; SAW HORSES; SCHOOL FURNITURE; SEATS; SOFAS; TABLES; TEA CARTS; TEA TROLLEYS; COMPUTER FURNITURE, NAMELY, TROLLEYS FOR COMPUTERS; UMBRELLA STANDS; COTS; CUPBOARDS; DISPLAY BOARDS; DRESSING TABLES; FOOTSTOOLS AND STOOLS; HAMPERS; NON-METAL CLOTHES HOOKS; CLOSET ACCESSORIES, NAMELY, SLIDING CLOTHES RAILS; LADDERS OF WOOD OR PLASTICS; MEDICINE CABINETS; REMOVABLE SINK MATS; NAME PLATES, NOT OF METAL; NUMBER PLATES, NOT OF METAL; PLAYPENS FOR BABIES; SCRATCHING POSTS FOR CATS; INDOOR WINDOW BLINDS; WORKS OF ART, FIGURINES AND STATUETTES AND SMALL GIFT PACKAGE DECORATIONS OR ORNAMENTS NOT BEING CHRISTMAS TREE ORNAMENTS, OF WOOD, CORK, REED, CANE, WICKER, HORN, BONE, IVORY, WHALEBONE, SHELL, AMBER, MOTHER-OF-PEARL, MEERSCHAUM AND SUBSTITUTES FOR THESE MATERIALS, OR OF WAX, PLASTER OR PLASTICS; NON-METAL BOTTLE CAPS; INFLATABLE SLEEPING BAG; INFLATABLE SOFA; INFLATABLE TABLE; WINDOW BLINDS OF TEXTILES; FRAMES FOR PHOTOGRAPHS (U.S. CLS. 2, 13, 22, 25, 32 AND 50).

CLASS 21—HOUSEWARES AND GLASS

FOR CONTAINERS, NOT OF PRECIOUS METAL OR COATED THEREWITH, FOR HOUSEHOLD AND KITCHEN USE; COMBS AND BATH SPONGES; HAIR BRUSHES; BRUSH-MAKING MATERIALS; ARTICLES FOR CLEANING PURPOSES, NAMELY, CLEANING CLOTHS AND CLEANING PADS; STEEL WOOL; UNWORKED OR SEMI-WORKED GLASS, NOT FOR CONSTRUCTION PURPOSES; BEVERAGE GLASSWARE, MUGS AND PLATES MADE OF PORCELAIN AND EARTHENWARE; PORTABLE BABY BATH TUBS; BREAD BASKETS FOR DOMESTIC USE; MUGS; NON-ELECTRIC FOOD BLENDERS; IRONING BOARDS; BOOTJACKS; BOTTLE OPENERS; STOPPERS FOR BOTTLES MADE OF/FROM CERAMICS, CHINA, GLASS,

CRYSTAL, EARTHENWARE, TERRA COTTA; BOTTLES SOLD EMPTY; BOWLS; SOAP BOXES; BREAD BOARDS; BUCKETS; TRAYS, NAMELY, MEAL TRAYS; CAGES FOR HOUSEHOLD PETS; CAKE MOULDS; WAFFLE MOULDS; CANDLE EXTINGUISHERS; CANDLE RINGS; CANDLESTICKS; CANDY BOXES; COMB CASES; CHINA ORNAMENTS; COOKING UTENSILS, NAMELY, CHOPSTICKS; CLOTHING STRETCHERS; CLOTHS FOR CLEANING; COASTERS NOT OF PAPER AND NOT BEING TABLE LINEN; COCKTAIL STIRRERS; WASHABLE COFFEE FILTERS NOT OF PAPER BEING PART OF NON-ELECTRIC COFFEE MAKERS; HAND-OPERATED COFFEE GRINDERS; NON-ELECTRIC COFFEE PERCOLATORS; COFFEE SERVICES; COFFEE POTS; ELECTRIC HAIR COMBS; COMBS FOR ANIMALS; PASTRY BAGS; COOKERY MOULDS; COOKING POTS; COOKING SKEWERS; PORTABLE COOLERS; FOOD COOLING RECEPTACLES CONTAINING HEAT EXCHANGE FLUIDS, FOR HOUSEHOLD PURPOSE; CORKSCREWS; COSMETIC UTENSILS, NAMELY, COSMETIC BRUSHES; COVERS FOR DISHES; COVERS FOR FLOWER POTS NOT OF PAPER; CROCKERY; CUPS; CUTTING BOARDS FOR THE KITCHEN; DECANTERS; DISHES FOR SOAP; SOAP DISPENSERS; DRINKING FLASKS; DRINKING GLASSES, TROUGHS, DRINKING VESSELS; CLOTHES DRYING RACKS; DUSTBINS; EGG CUPS; FLOWER POTS; FLY CATCHERS; GLOVES FOR HOUSEHOLD PURPOSES; GOBLETS; CHEESE GRATERS; NON-ELECTRIC GRIDDLES; HEAT-INSULATED CONTAINERS FOR FOOD OR BEVERAGES; HEATERS FOR FEEDING BOTTLES, NON-ELECTRIC; HOLDERS FOR FLOWERS AND PLANTS; HOT POTS; ICE BUCKETS; ICE CUBE MOULDS; IRONING BOARD COVERS; JUGS; NON-ELECTRIC KETTLES; KNIFE RESTS; KNOBS OF PORCELAIN; LAZY SUSANS; LUNCH BOXES; MENU CARD HOLDERS; MIXING SPOONS; MOPS; NAPKIN HOLDERS; NAPKIN RINGS; NOZZLES FOR WATERING CANS; PADS FOR CLEANING; PANS; PAPER PLATES; PASTRY CUTTERS; PEPPER MILLS; PERFUME, AROMATICS, ESSENTIAL OILS AND FRAGRANCE BURNERS; PERFUME SPRAYERS SOLD EMPTY; VAPORIZERS FOR PERFUME SOLD EMPTY; FITTED PICNIC BASKETS; NON-METAL PIGGY BANKS; POT LIDS; POTS; NON-ELECTRIC PRESSURE COOKERS; REFUSE BINS; SALT SHAKERS; PEPPER SHAKERS; SAUCEPANS; SAUCERS; SCOOPS; SCOURING PADS; SHAVING BRUSHES; SHOE BRUSHES; SHOE HORNS; SHOE TREES; SIEVES; SOAP HOLDERS; SOUP BOWLS; SPONGE HOLDERS; SPONGES FOR HOUSEHOLD PURPOSES; STANDS FOR SHAVING BRUSHES; STATUES OF PORCELAIN, TERRA-COTTA OR GLASS; STATUETTES OF PORCELAIN, TERRA COTTA OR GLASS; COOKING STRAINERS; SYRINGES FOR WATERING FLOWERS AND PLANTS; TABLEWARE, NAMELY, DISHES; TANKARDS; TEA BALLS; TEA CADDIES; TEA SERVICES; TEAPOTS; TOILET BRUSHES; TOILET CASES, NAMELY, FITTED VANITY CASES; TOILET PAPER HOLDERS; TOILET SPONGES; TOILET UTENSILS, NAMELY, TOILET BRUSHES; TOOTHBRUSHES; TOOTHBRUSHES, ELECTRIC; TOOTHPICK HOLDERS; TOOTHPICKS; TRASH CANS; LITTER TRAYS; TRAYS FOR DOMESTIC PURPOSES; TRIVETS; VACUUM BOTTLES; FITTED VANITY CASES; VASES; WAFFLE AND PANCAKE IRONS, NON-ELECTRIC; NON-ELECTRIC COOKERY AND BAKING IRONS, NAMELY, WAFFLE AND PANCAKE IRONS; WASHING BOARDS; WASH TUBS; WATERING CANS; WORKS OF ART, OF PORCELAIN, TERRA COTTA OR GLASS; DECORATIVE ORNAMENTS FOR WINDOWS OR DOORS MADE OF/ FROM CERAMICS, CHINA, GLASS, CRYSTAL, EARTHENWARE, TERRA COTTA OR PORCELAIN; HOUSEHOLD FOOD BOXES AND CONTAINERS NOT OF PRECIOUS METAL; FLOSS FOR DENTAL PURPOSES; CONTAINERS FOR AROMATICS AND FRAGRANCES SOLD EMPTY; REFRIGERATING BOTTLES, NAMELY, PORTABLE BEVERAGE COOLERS; BOXES OF GLASS; BROOMS; CAULDRONS; HAND-OPERATED CLEANING INSTRUMENTS, NAMELY, BROOMS; CLOTHES PEGS; NON-ELECTRIC PORTABLE COLD BOXES, NAMELY, PORTABLE COOLERS; COOKIE JARS; EYEBROW BRUSHES; BRUSHES FOR FOOTWEAR; FUNNELS; GARDENING GLOVES; GLASS FLASKS; INSULATING FLASKS; POWDER PUFFS; COCKTAIL SHAKERS; TEA-STRAINERS; MULTIPURPOSE SHEETS FOR HOUSEHOLD OR KITCHEN PURPOSES, NAMELY, COOKIE SHEETS; WHISKS; NON-ELECTRIC EGG BEATERS; VESSELS OF METAL FOR MAKING ICES AND ICED DRINKS; COOKIE CUTTERS; CRUETS; CRUET

STANDS; DUSTERS; COCKTAIL SHAKERS; POWDER COMPACTS SOLD EMPTY; TISSUE PAPER BOX COVERS OF WOOD OR PLASTIC; STANDS FOR TOOTH BRUSHES; HOUSEHOLD CONTAINERS OF PRECIOUS METAL; HOUSEHOLD UTENSILS OF PRECIOUS METAL, NAMELY, GRATERS; COFFEE SERVICES OF PRECIOUS METAL; COFFEEPOTS OF PRECIOUS METAL, NON-ELECTRIC; KITCHEN CONTAINERS OF PRECIOUS METAL; NAPKIN HOLDERS AND RINGS OF PRECIOUS METAL; POWDER COMPACTS OF PRECIOUS METAL SOLD EMPTY; LUNCH BAGS; DISH RACKS; SEALING CLIPS FOR BAGS; PLASTIC CONTAINERS FOR FRAGRANCES AND AROMATICS SOLD EMPTY (U.S. CLS. 2, 13, 23, 29, 30, 33, 40 AND 50).

CLASS 24—FABRICS

FOR TEXTILES AND TEXTILE GOODS, FABRICS, NAMELY, TOWELS; HANDKERCHIEFS; TEXTILE NAPKINS; BED AND TABLE COVERS; CLOTH BANNERS; BATH LINEN; BED LINEN; BEDSPREADS; BED BLANKETS; DISH CLOTHS; UNFITTED FURNITURE COVERINGS OF TEXTILE; COVERINGS OF PLASTIC FOR FURNITURE; COVERS FOR CUSHIONS; DOOR CURTAINS; FABRIC OF IMITATION ANIMAL SKINS; TOWELS; FABRIC FLAGS; TOILET GLOVES, NAMELY, BATH GLOVES; HOUSEHOLD LINEN; CLOTH LABELS; CLOTH NAPKINS FOR REMOVING MAKE-UP; TEXTILE PLACE MATS; MATTRESS COVERS; WASHING MITTS; MOSQUITO NETS; CURTAINS; PILLOWCASES; PLASTIC MATERIAL IN THE NATURE OF SUBSTITUTE FOR FABRICS, NAMELY, TEXTILE SUBSTITUTE MATERIALS MADE FROM SYNTHETIC MATERIALS; DUVET COVERS; QUILTS; TRAVELLING RUGS; TEXTILE BED SHEETS; SHROUDS; SILK FABRICS; TABLE LINEN; TABLE LINEN IN THE NATURE OF TABLE MATS; TEXTILE TABLE NAPKINS; TEXTILE TAPETRY; UPHOLSTERY FABRICS; WALL HANGINGS OF TEXTILE; TEXTILE TOILET SEAT COVERS; TEXTILE COVERINGS FOR LIDS FOR TOILET VESSELS; FABRIC CURTAIN HOLDERS AND TIEBACKS OF TEXTILE; TABLE LINEN, NAMELY, COASTERS; COTTON FABRICS; COVERLETS IN THE NATURE OF BEDSPREADS; FABRICS FOR TEXTILE USE; FACE TOWELS OF TEXTILE; FELT; CLOTH IN THE NATURE OF FRIEZE; HEMP BASE MIXED FABRICS; TABLE CLOTHS NOT OF PAPER; VELVET; WOOLLEN CLOTH; TISSUES OF TEXTILE FOR REMOVING MAKE-UP; NAME LABELS OF TEXTILE; WOVEN FABRIC LABELS (U.S. CLS. 42 AND 50).

CLASS 25—CLOTHING

FOR ARTICLES OF CLOTHING FOR ADULT AND CHILDREN, NAMELY, T-SHIRTS, TANK TOPS, SWEATERS, CARDIGANS, SWEATSHIRTS, TIGHTS, LEGGINGS, PULLOVERS, JEANS, TROUSERS, SHORTS, SKIRTS, BLOUSES, DRESSES, APRON DRESSES, RAIN COAT, SINGLET, JOGGING SUITS, CHILDREN'S OVERALLS; FOOTWEAR, HEADGEAR, NAMELY, HATS AND CAPS; APRONS; BEACH CLOTHES, NAMELY, SARONG, BEACH COVER UPS; SWIMWEAR, SWIMSUITS; WATERPROOF CLOTHING, NAMELY, RAIN COATS, JACKETS, TROUSERS, GLOVES, MITTENS AND HATS; GLOVES; MITTENS; BELTS; BABIES' CLOTHING, NAMELY, T-SHIRTS, BABY BODY SUITS, ROMPER, BABY BOOTIES, OVERALLS; BABIES' NAPKINS OF TEXTILES, NAMELY, CLOTH DIAPERS; BIBS, NOT OF PAPER; UNDERCLOTHING; SLEEP WEAR AND PYJAMAS; BATH ROBES; SUSPENDERS; SUN VISORS; BEREETS; BATHING AND SHOWER CAPS; MUFFS; EAR MUFFS; NECKWEAR, NECKTIES, CRAVATS, BOW TIES; SOCKS AND STOCKINGS, PANTY HOSES; GARTER BELTS, SOCKS, STOCKING AND PANTY HOSE SUSPENDERS; SHOES, SPORTS SHOES, SLIPPERS, BEACH SHOES; MASQUERADE COSTUMES; WORKING SLEEVES; KERCHIEFS; NECKERCHIEFS, NAMELY, BANDANAS; BATH SANDALS; BATH SLIPPERS; SKI BOOTS; BOOTS; SUSPENDERS, NAMELY, BRACES FOR CLOTHING; BRASSIERES; BREECHES FOR WEAR;

CAMISOLES; COATS; CUFFS; FUR STOLES; HEADBANDS; JACKETS; JERSEYS; JUMPERS; OUTER CLOTHING, NAMELY, OVERALLS, JACKETS, VESTS AND TROUSERS; OVERCOATS; PANTS; PARKAS; PULLOVERS; SANDALS; SCARVES; SHAWLS; SHIRTS; UNDERGARMENTS IN THE NATURE OF SLIPS; SMOCKS; SPATS; BOOTS FOR SPORTS; SPORTS JERSEYS; SUITS; BATHING SUITS; TEE-SHIRTS; TROUSERS; UNDERWEAR; UNIFORMS; VESTS; WET SUITS FOR WATER SKIING; WRISTBANDS; LINGERIE; GYM-NASTICS SHOES; SASHES FOR WEAR (U.S. CLS. 22 AND 39).

CLASS 28—TOYS AND SPORTING GOODS

FOR TOYS, GAMES AND PLAYTHINGS, NAMELY, PARTY GAMES, LOTTO GAMES, MEMORY GAMES AND CARD GAMES; DOLLS; PLUSH TOYS; TEDDY BEARS; TOY FIGURES AND PLAY SETS; PLAYGROUND BALLS AND BALLOONS; DECORATIONS AND ORNAMENTS FOR CHRISTMAS TREES; PARTY FAVORS IN THE NATURE OF SMALL TOYS; TOY VEHICLES; ELECTRIC TOY VEHICLES; SURFBOARDS; SNOW BOARDS; IN-LINE SKATES; ICE SKATES; SKATEBOARDS; ELBOW, WRIST, MOUTH AND SHIN GUARDS FOR ATHLETIC USE; TOY AIR PISTOLS; BACKGAMMON GAMES; BALLS FOR GAMES; BELLS FOR CHRISTMAS TREES; BILLIARD BALLS; BILLIARD TABLES; BUILDING BLOCKS; BOARD GAMES; EXPLOSIVE BONBONS, NAMELY, CHRISTMAS CRACKERS; SKATING BOOTS WITH SKATES ATTACHED; BOWLING APPARATUS AND MACHINERY; BUILDING GAMES; CANDLE HOLDERS FOR CHRISTMAS TREES; CHECKERBOARDS; CHECKERS GAMES; CHESS GAMES; CHESSBOARDS; CHRISTMAS TREES OF SYNTHETIC MATERIALS; CONJURING APPARATUS, NAMELY, MAGIC TRICKS; COSAQUES, NAMELY, TOY CRACKERS OR FIREWORKS; CUPS FOR DICE; DARTS; DICE; DOLLS' BEDS; DOLLS' CLOTHES; DOLLS' HOUSES; DOLLS' ROOMS; DOMINOES; DUMB-BELLS; ELBOW GUARDS FOR ATHLETIC USE; EXERCISE EQUIPMENT, NAMELY, CHEST EXPANDERS; FAIRGROUND RIDE APPARATUS, NAMELY, AMUSEMENT PARK RIDES; DOLLS' FEEDING BOTTLES; FISH HOOKS; FISHING TACKLE; FLIPPERS FOR SWIMMING; FLOATS FOR FISHING; FLYING DISCS; BATS FOR GAMES; APPARATUS FOR ELECTRONIC GAMES OTHER THAN THOSE ADAPTED FOR USE WITH TELEVISION RECEIVERS ONLY; GOLF BAGS; GOLF CLUBS; GOLF GLOVES; KITE REELS; KITES; KNEE GUARDS FOR ATHLETIC USE; MAH-JONG; MARBLES FOR GAMES; MARIONETTES; THEATRICAL MASKS; TOY MASKS; TOY MOBILES; SCALE MODEL VEHICLES; NOVELTIES FOR PARTIES IN THE NATURE OF SMALL PARTY FAVOR TOYS; PROTECTIVE PADDING, NAMELY, FOOTBALL SHOULDER PADS; PARLOUR GAMES; TOY PERCUSSION CAPS; TOY PISTOLS; PLAYGROUND BALLS; PUPPETS, RACKETS, NAMELY, TENNIS RACKETS; BABY RATTLES; RING GAMES; ROCKING HORSES; ROLLER SKATES; SAILBOARDS; SKIS; BOB-SLEIGHS; PLAYGROUND EQUIPMENT, NAMELY, SLIDES; BUBBLE MAKING WAND AND SOLUTION SETS; SPINNING TOPS; SPORTING ARTICLES, NAMELY, SPRING BOARDS; STATIONARY EXERCISE BICYCLES; PLAY SWIMMING POOLS; SWIMMING FLIPPERS; SWINGS; TABLES FOR TABLE TENNIS; TOYS FOR DOMESTIC PETS; WATER-SKIS; PLAY ARTICLES FOR SWIMMING, WATER GAMES, SPORTS AND ACTIVITIES, NAMELY, BALLS, BATH AND SWIM RING, INFLATABLE MATTRESS, ARM FLOAT BANDS, KICK BOARD AND BABY SWIM FLOAT, SWIM VEST ALL FOR RECREATIONAL USE; BEACH BALLS; AUTOMATIC COIN-OPERATED AMUSEMENT MACHINES; BAGS ESPECIALLY DESIGNED FOR SKIS AND SURFBOARDS; BINGO CARDS; TOY BUTTERFLY NETS; PLAYING CARDS; CONFETTI; IN-LINE ROLLER SKATES; JIGSAW PUZZLES; KALEIDOSCOPIES; MASTS FOR SAILBOARDS; SURFBOARDS; LANDING NETS FOR ANGLERS; RADIO-CONTROLLED TOY VEHICLES; ROULETTE WHEELS; SNOW GLOBES; SNOWSHOES; JAPANESE PLAYING CARDS; INFLATABLE SURF BOARDS (U.S. CLS. 22, 23, 38 AND 50).

CLASS 29—MEATS AND PROCESSED FOODS

FOR PRESERVED, DRIED AND COOKED FRUITS AND VEGETABLES; JELLIES, JAMS; MILK AND MILK PRODUCTS EXCLUDING ICE CREAM, ICE MILK AND FROZEN YOGURT; CHEESE, SNACKS IN THE NATURE OF CHEESE; DAIRY PRODUCTS EXCLUDING ICE CREAM, ICE MILK AND FROZEN YOGHURT; FROSTED FRUITS; FROZEN FRUITS; FRUIT CHIPS; MARMALADE; MILK BEVERAGES CONTAINING FRUITS; PREPARED NUTS; PEANUT BUTTER; PROCESSED PEANUTS; FRUIT PEEL; POTATO CHIPS; POTATO CRISPS; POTATO FRITTERS; TOFU; YOGURT; POTATO-BASED SNACK FOODS AND NUT-BASED SNACK FOODS, NAMELY, NUT BARS; PROCESSED, EDIBLE SEAWEEDS; CHOCOLATE NUT BUTTER; CRYSTALLIZED FRUITS; FRUIT JELLIES; FRUIT SALADS; CANNED FRUITS; RAISINS; PATES; PICKLES (U.S. CL. 46).

CLASS 30—STAPLE FOODS

FOR COFFEE; TEA; COCOA; SUGAR; RICE; TAPIOCA; SAGO; ARTIFICIAL COFFEE; BREAD; PASTRY AND CONFECTIONERY CHIPS FOR BAKING; EDIBLE ICES; HONEY; TREACLE; ICE; BISCUITS; CAKE MIX; EDIBLE DECORATIONS FOR CAKES; FLAVORINGS FOR CAKES OTHER THAN ESSENTIAL OILS; RICE CAKES; SWEETS AND CANDIES; CHOCOLATE; CHOCOLATE BEVERAGES WITH MILK; CHOCOLATE-BASED FOOD BEVERAGES NOT BEING DAIRY-BASED OR VEGETABLE BASED; CONFECTIONERY FOR DECORATING CHRISTMAS TREES; COCOA BEVERAGES WITH MILK; COCOA PRODUCTS, NAMELY, COCOA POWDER; COCOA-BASED BEVERAGES; COFFEE-BASED BEVERAGES; COFFEE FLAVORINGS OTHER THAN ESSENTIAL OILS; COFFEE SUBSTITUTES IN THE NATURE OF MIXTURES AND PREPARATIONS FOR USE AS SUBSTITUTES FOR COFFEE; COFFEE-BASED BEVERAGES; COOKIES; POPCORN; CORN FLAKES; ICE-CREAM; CUSTARD; BREAKFAST CEREALS, NAMELY, CEREAL FLAKES; FLAVORINGS, OTHER THAN ESSENTIAL OILS; CONFECTIONERY ICES; CONFECTIONERY, NAMELY, FRUIT JELLIES; GINGERBREAD; TABLE SYRUP; HERBAL INFUSIONS; KETCHUP; LIQUORICE; NON-MEDICATED LOZENGES; MEAT PIES; PANCAKES; PASTILLES; PASTRIES; PEPPER; PIZZAS; PUDDINGS; RAVIOLI; ROYAL JELLY FOR HUMAN CONSUMPTION; WASABI PASTE; SOY SAUCE; PASTAS, NOODLES AND VERMICELLI; UDON (JAPANESE STYLE NOODLES); SUSHI; VANILLA; WAFFLES; FROZEN YOGHURT; PRETZELS; ALMOND CAKE; AROMATIC PREPARATIONS FOR FOOD, NAMELY, SCENTED WATER FOR FLAVORING BEVERAGES; STARCH-BASED BINDING AGENTS FOR ICE CREAM; BREAD ROLLS; BUNS; CAKES; CARAMELS; CHEWING GUM, NOT FOR MEDICAL PURPOSES; CRACKERS; EDIBLE ICES; GOLDEN MAPLE SYRUP; ICE, NATURAL OR ARTIFICIAL; MACARONI; MARZIPAN; MAYONNAISE; PIES; RUSKS; SANDWICHES; TOMATO SAUCE; SEASONINGS; SHERBETS; SPAGHETTI; CANDY IN THE NATURE OF SWEETMEATS; TARTS; WHEAT FLOUR; SALAD DRESSINGS; FRUIT SAUCES EXCLUDING CRANBERRY SAUCE AND APPLESAUCE; SAUCE (U.S. CL. 46).

CLASS 32—LIGHT BEVERAGES

FOR BEERS; MINERAL AND AERATED WATERS; FRUIT DRINKS AND FRUIT JUICES; SYRUPS FOR MAKING BEVERAGES, FRUIT CONCENTRATES USED AS INGREDIENTS OF BEVERAGES; ISOTONIC BEVERAGES; NON-ALCOHOLIC FRUIT NECTARS; PASTILLES FOR EFFERVESCING BEVERAGES; POWDERS FOR EFFERVESCING BEVERAGES; SODA WATER; SYRUPS FOR BEVERAGES; TABLE WATERS; DRINKING WATERS; WHEY BEVERAGES; SOFT DRINKS; NON-ALCOHOLIC COCKTAILS AND APERITIFS (U.S. CLS. 45, 46 AND 48).

CLASS 35—ADVERTISING AND BUSINESS

FOR WHOLESALE AND RETAIL STORE SERVICES AND MAIL ORDER SERVICES FEATURING PARTY FAVORS AND FESTIVE DECORATIONS AND ORNAMENTS, GIFTS AND NOVELTY ITEMS, SOAPS, PERFUMERY, ESSENTIAL OILS, COSMETICS, HAIR CARE PRODUCTS, TOILETRIES, DENTIFRICES, PERSONAL HYGIENE PRODUCTS, MANICURE TOOLS, NAIL CARE PREPARATIONS, NAIL POLISH, NAIL VARNISH, FALSE NAILS, SANITARY PREPARATIONS, CANDLES, WICKS, SPILLS FOR LIGHTING, OILS FOR PAINTS, CUTLERY, CROCKERY, MANICURE SETS, SHAVING INSTRUMENTS, RAZORS, MACHINES AND MACHINE TOOLS FOR KITCHEN OR HOUSEHOLD PURPOSES, HAND-HELD TOOLS, FILMS, CAMERAS, PHOTO DISCS, VIDEO RECORDERS, AUDIO AND VISUAL PRODUCTS, AUDIO AND VIDEO TAPES, RECORDS AND DISCS, INSTRUMENTS AND APPARATUS FOR THE RECORDING, TRANSMITTING AND/OR REPRODUCTION OF SOUNDS AND/OR IMAGES, TELEVISIONS, VIDEO CASSETTE AND/OR DISC PLAYERS AND/OR RECORDERS, RADIOS, TELEPHONES, WIRELESS PHONES, MOBILE PHONES, MOBILE PHONE CASES, DECORATIONS AND STRAPS FOR PHONES, CALL INDICATORS, CALCULATING MACHINES, CALCULATORS, ELECTRONIC AND COMPUTER GAMES, CINEMATOGRAPHIC FILMS, LIGHTS, FANS, COOKING UTENSILS, CAKE AND PASTRY MOULDS, TOASTERS, OVENS, KITCHEN UTENSILS, UTENSILS AND CONTAINERS FOR SERVING OR STORING FOOD AND/OR BEVERAGES, CHOP STICKS, CUTTING INSTRUMENTS, PORCELAIN, CRYSTAL WARE, ENAMELWARE, SILVERWARE, GLASSWARE, TERRA COTTA WARE, EARTHENWARE, CERAMICS, HAIR DRYERS, LAMPS, LAMP SHADES AND PARTS AND FITTINGS THEREFORE, BABY CARRIAGES, BALLOONS, BICYCLE HORNS, CLOCKS AND WATCHES AND ACCESSORIES AND PARTS AND FITTINGS THEREFORE, JEWELLERY AND IMITATION JEWELLERY, ORNAMENTS, GOODS IN PRECIOUS METAL OR COATED THERewith, PICTURES, PHOTOGRAPHS, STATIONERY, PAPER AND CARDBOARD AND GOODS MADE FROM THESE MATERIALS, ARTISTS MATERIALS, PAINT BRUSHES, WRITING INSTRUMENTS, PRINTED MATTER, BOOKS, NEWSPAPERS, MAGAZINES AND PERIODICALS, GREETING AND CHRISTMAS CARDS, PLAYING CARDS, PACKING AND PACKAGING MATERIALS, PICTURE FRAMES AND STANDS, ADHESIVES FOR STATIONERY OR HOUSEHOLD PURPOSES, GOODS MADE OF LEATHER AND/OR IMITATIONS OF LEATHER, BAGS AND LUGGAGE, PURSES AND WALLETs, UMBRELLAS, WALKING STICKS, FURNITURE, MIRRORS, COAT HANGERS AND PEGS, BOXES AND CONTAINERS, NAME PLATES, SMALL HOUSEHOLD FITTINGS, HOUSEHOLD OR KITCHEN UTENSILS AND CONTAINERS, COMBS, SPONGES, BRUSHES, ARTICLES FOR CLEANING PURPOSES, SPECTACLES, SPECTACLE FRAMES AND SUNGLASSES AND CASES AND ACCESSORIES THEREFORE, TEXTILE AND TEXTILE GOODS, BEDDING, AND TABLE LINENS AND COVERS, NAPKINS, TABLE MATS, FURNITURE, HABERDASHERY, HANDKERCHIEFS, ARTICLES OF CLOTHING, FOOTWEAR AND HEADGEAR, BUTTONS, BADGES, RIBBONS AND BRAID, LACE AND EMBROIDERY, HAIR PINS AND ORNAMENTS, BRACES, SHOE ORNAMENTS, HAT ORNAMENTS, CARPETS, RUGS AND MATS, TOYS, GAMES AND PLAYTHINGS, DOLLS, FIGURINES, SPORTING ARTICLES, DECORATIONS FOR CHRISTMAS TREES, FOOD AND BEVERAGES, CONFECTIONERY AND MATCHES; ADVERTISING AND PROMOTIONAL SERVICES; ORGANIZATION OF EXHIBITIONS FOR COMMERCIAL OR ADVERTISING PURPOSES; PUBLICATION OF PUBLICITY TEXTS; SALES PROMOTION SERVICES FOR OTHERS; ADVERTISING AGENCIES; BUSINESS MANAGEMENT OF PERFORMING ARTISTS; IMPORT-EXPORT AGENCIES; COMPILATION AND SYSTEMIZATION OF INFORMATION INTO COMPUTER DATABASES; DIRECT MAIL ADVERTISING; BUSINESS MANAGEMENT OF HOTELS; MARKETING SERVICES, NAMELY, CONSUMER MARKETING RESEARCH; PREPARING AND PLACING OUTDOOR ADVERTISEMENTS FOR OTHERS; PERSONNEL RECRUITMENT; PUBLICITY AGENCIES; ADVERTISING SERVICES, NAMELY, PREPARING AND PLACING ADVERTISEMENTS FOR OTHERS ON RADIO, TELEVISION AND ON-LINE ON A COMPUTER NETWORK; PROCUREMENT SERVICES FOR OTHERS, NAMELY,

PURCHASING GOODS AND SERVICES FOR OTHER BUSINESSES IN THE NATURE OF TOYS, GAMES AND PLAYTHINGS, BOOKS AND CLOTHING, STATIONARY, AND PREPARATIONS FOR HAIR AND SKIN (U.S. CLS. 100, 101 AND 102).

CLASS 38—COMMUNICATION

FOR COMMUNICATIONS THROUGH MOBILE PHONES; TRANSMISSION OF MESSAGES WITH USE OF ELECTRONIC MEDIA; TRANSMISSION OF MESSAGES (U.S. CLS. 100, 101 AND 104).

CLASS 41—EDUCATION AND ENTERTAINMENT

FOR ENTERTAINMENT, NAMELY, PROVIDING NON-DOWNLOADABLE ON-LINE COMPUTER GAMES AND ONLINE INTERACTIVE DATABASE OF VIDEOS IN THE FIELD OF CHILDREN'S EDUCATION AND ENTERTAINMENT VIA THE INTERNET, VIDEO ON DEMAND, ELECTRONIC STREAMING, WEB-CASTING, MOBILE PHONES AND/OR TELEVISION; AMUSEMENT CENTERS; AMUSEMENT PARKS, PROVIDING THEME PARK SERVICES; AMUSEMENT ARCADE SERVICES; EDUCATIONAL SERVICES FOR CHILDREN, NAMELY, CONDUCTING CLASSES, SEMINARS, WORKSHOPS IN THE FIELD OF LANGUAGE, CULTURE, VISUAL ART BY MEANS OF TELEVISION, VIDEO RECORDINGS OR INTERNET; TELEVISION SHOW PRODUCTION; ENTERTAINMENT IN THE NATURE OF THEATER PRODUCTIONS; PRESENTATION OF LIVE SHOW PERFORMANCES AND LIVE COMEDY SHOWS; MUSIC HALLS; PROVISION OF CINEMA FACILITIES; PRODUCTION OF CABARETS; MOVIE STUDIOS; DISCOTHEQUE SERVICES; NIGHT CLUB SERVICES; PUBLICATION OF BOOKS, TEXTS, MAGAZINES, NEWSPAPERS AND PERIODICALS; LIBRARY SERVICES; PROVIDING FACILITIES FOR ENTERTAINMENT, NAMELY, GAME SHOWS, PROVIDING FACILITIES FOR EXHIBITIONS, PROVIDING SPORTS FACILITIES, AND PROVIDING FACILITIES FOR RECREATION ACTIVITIES; PROVISION OF INFORMATION RELATING TO EDUCATION, ENTERTAINMENT, AMUSEMENT, RECREATION, SPORTS AND CULTURE; TELEVISION AND RADIO ENTERTAINMENT, NAMELY, PRODUCTION OF RADIO AND TELEVISION PROGRAMS; FILM AND VIDEO FILM PRODUCTION; RENTAL OF CINE-FILMS, MOTION PICTURES, VIDEO TAPES, LASER DISCS, VIDEO DISCS AND DIGITAL VERSATILE VIDEO DISCS; NIGHT CLUBS FEATURING AUDIO AND VISUAL APPARATUS WITH SING ALONG DEVICES; ENTERTAINMENT SERVICES, NAMELY, LIVE PERFORMANCES AND PERSONAL APPEARANCES BY A COSTUMED CHARACTER AND LIVE PERFORMANCES AT STAGE SHOWS, AND TELEVISION AND MOVIE APPEARANCES BY A PROFESSIONAL ENTERTAINER; ORGANIZATION OF EXHIBITIONS FOR CULTURAL OR EDUCATIONAL PURPOSES; GAMING, NAMELY, CASINO SERVICES; PARTY PLANNING; ENTERTAINMENT IN THE NATURE OF THEATER PRODUCTIONS; DIGITAL IMAGING SERVICES; ELECTRONIC DESKTOP PUBLISHING FOR OTHERS; ENTERTAINMENT SERVICES, NAMELY, PROVIDING AN ONLINE COMPUTER GAME; PROVIDING ONLINE POKER GAMES, SIGN LANGUAGE INTERPRETATION; EDUCATIONAL AND TRAINING ADVICE SERVICES, NAMELY, VOCATIONAL GUIDANCE; MICROFILMING FOR OTHERS; MUSIC COMPOSITION SERVICES FOR OTHERS; NIGHT CLUBS; PHOTOGRAPHY; VIDEO TAPE FILM PRODUCTION; PROVIDING KARAOKE SERVICES; PROVIDING ON-LINE ELECTRONIC PUBLICATIONS, NOT DOWNLOADABLE, IN THE NATURE OF BOOKS AND MAGAZINES FEATURING CARTOON CHARACTERS IN THE FIELD OF CARTOON ENTERTAINMENT; PUBLICATION OF ELECTRONIC BOOKS AND JOURNALS ON-LINE; VIDEOTAPING (U.S. CLS. 100, 101 AND 107).

SUE LAWRENCE, EXAMINING ATTORNEY

SN 79-068,271. JARDINE LLOYD THOMPSON IRELAND; LIMITED, IRELAND, FILED 11-18-2008.

JLT

THE MARK CONSISTS OF STANDARD CHARACTERS WITHOUT CLAIM TO ANY PARTICULAR FONT, STYLE, SIZE, OR COLOR.

PRIORITY DATE OF 10-20-2008 IS CLAIMED.
OWNER OF INTERNATIONAL REGISTRATION 1001315 DATED 11-18-2008, EXPIRES 11-18-2018.
OWNER OF U.S. REG. NO. 3,173,687.

CLASS 35—ADVERTISING AND BUSINESS

FOR MARKETING AND PROMOTION SERVICES RELATING TO INSURANCE, REINSURANCE AND INSURANCE AND REINSURANCE BROKERS AND EMPLOYEE BENEFITS; BUSINESS MANAGEMENT AND ADMINISTRATION SERVICES RELATING TO INSURANCE AND INSURANCE BROKERS AND REINSURANCE AND REINSURANCE BROKERS; DATA PROCESSING SERVICES RELATING TO INSURANCE AND INSURANCE BROKERS AND REINSURANCE AND REINSURANCE BROKERS; DATA PROCESSING SERVICES RELATING TO PENSIONS ADMINISTRATION AND EMPLOYEE BENEFITS; BUSINESS MANAGEMENT SERVICES RELATING TO MANAGEMENT AND ADMINISTRATION OF PAYROLL AND PENSIONS FOR EMPLOYEES AND THIRD PARTY PENSION SCHEMES; ADMINISTRATION, MANAGEMENT, IMPLEMENTATION AND CO-ORDINATION OF HUMAN RESOURCES FOR OTHERS, NAMELY, HUMAN RESOURCES MANAGEMENT FOR OTHERS; BUSINESS ADMINISTRATION SERVICES FOR OTHERS IN THE FIELD OF HUMAN RESOURCES; DATABASE MANAGEMENT SERVICES; BUSINESS PROCESS OUTSOURCING SERVICES IN THE FIELD OF INSURANCE BROKERING AND EMPLOYEE BENEFITS, BUSINESS PROCESS OUTSOURCING IN THE FIELD OF PAYROLL AND PENSION PLANS; COMPUTERIZED FILE MANAGEMENT; ADVISORY SERVICES RELATING TO BUSINESS RISK MANAGEMENT; BUSINESS RISK MANAGEMENT SERVICES; BUSINESS MANAGEMENT AND ADMINISTRATION OF CAPTIVE INSURANCE COMPANIES FOR THIRD PARTIES; BUSINESS RESEARCH SERVICES FOR CLIENTS ENGAGED IN THE COLLECTION, STORAGE AND PROCESSING OF FINANCIAL INFORMATION; MANAGING GENERAL INSURANCE AGENTS AND UNDERWRITING INSURANCE AGENTS (U.S. CLS. 100, 101 AND 102).

CLASS 36—INSURANCE AND FINANCIAL

FOR FINANCIAL SERVICES, NAMELY, INVESTMENT OF FUNDS FOR THIRD PARTIES; ADMINISTRATION OF EMPLOYEE PENSION PLANS FOR THIRD PARTIES; FINANCIAL ADMINISTRATION OF RETIREMENT PENSION PLANS FOR THIRD PARTIES; FINANCIAL MANAGEMENT OF PENSION FUNDS, PENSION SCHEMES, MUTUAL FUNDS, INVESTMENT FUNDS AND UNIT TRUSTS; ACTUARIAL SERVICES; INSURANCE AND ASSURANCE SERVICES, NAMELY, INSURANCE BROKERING AND CONSULTATION FEATURING ADVISING ON INSURANCE RISKS, PLACING RISKS, PROCESSING AND ADMINISTRATION OF INSURANCE CLAIMS ON BEHALF OF CLIENTS, NAMELY, INSURANCE BROKERAGES SERVICES, PROVIDING INFORMATION IN INSURANCE MATTERS PERTAINING TO INSURANCE RISKS, AND PROCESSING AND ADMINISTRATION OF INSURANCE CLAIMS ON BEHALF OF CLIENTS; INSURANCE UNDERWRITING SERVICES IN THE FIELDS OF RETAIL, WHOLESAL, AND CORPORATE RISKS, NAMELY, ACCIDENT, FIRE, LIFE AND THEFT INSURANCE; INSURANCE SERVICES, NAMELY, INSURANCE AGENCY AND BROKERAGE SERVICES; INSURANCE

BROKERAGE AND REINSURANCE UNDERWRITING IN THE FIELDS OF MARINE, NON-MARINE AND AVIATION; INSURANCE BROKERAGE AND FISCAL VALUATION SERVICES; FINANCIAL PLANNING AND FINANCIAL ADVISORY SERVICES IN THE FIELD OF PENSIONS; ADMINISTRATION OF INSURANCE POLICIES AND INSURANCE CLAIMS ADMINISTRATION AND PROCESSING; CLAIMS ADJUSTMENT SERVICES FOR INSURANCE RELATED CLAIMS; INFORMATION, ADVISORY AND CONSULTANCY SERVICES IN THE FIELD OF THE AFORESAID SERVICES (U.S. CLS. 100, 101 AND 102).

REGINA DRUMMOND, EXAMINING ATTORNEY

SN 79-077,205. PRAMAC S.P.A., ITALY, FILED 10-2-2009.

PRAMAC

THE MARK CONSISTS OF STANDARD CHARACTERS WITHOUT CLAIM TO ANY PARTICULAR FONT, STYLE, SIZE, OR COLOR.

PRIORITY DATE OF 9-28-2009 IS CLAIMED.
OWNER OF INTERNATIONAL REGISTRATION 1024562 DATED 10-2-2009, EXPIRES 10-2-2019.

CLASS 7—MACHINERY

FOR LIFTING MACHINES AND APPARATUS, NAMELY, CAR LIFTS, ELEVATORS, LIFTING INSTALLATIONS FOR THE TRANSPORT OF PERSONS AND GOODS, MECHANICAL LIFTS; GENERATORS IN THE NATURE OF ELECTRICITY GENERATORS, NAMELY, ENGINE-DRIVEN ELECTRICAL POWER GENERATORS; CONVEYORS, NAMELY, PALLET CONVEYORS (U.S. CLS. 13, 19, 21, 23, 31, 34 AND 35).

CLASS 12—VEHICLES

FOR LIFTING CARS, LIFT CARS AND CONVEYING CARS, PALLET TRUCKS AND FORK-LIFT TRUCKS (U.S. CLS. 19, 21, 23, 31, 35 AND 44).

RAMONA ORTIGA, EXAMINING ATTORNEY

SN 79-079,012. GRAZIELLA PALETTA, ITALY, FILED 12-23-2009.

MY STAR

THE MARK CONSISTS OF STANDARD CHARACTERS WITHOUT CLAIM TO ANY PARTICULAR FONT, STYLE, SIZE, OR COLOR.

PRIORITY DATE OF 7-22-2009 IS CLAIMED.
OWNER OF INTERNATIONAL REGISTRATION 1029040 DATED 12-23-2009, EXPIRES 12-23-2019.

CLASS 14—JEWELRY

FOR PRECIOUS METALS AND THEIR ALLOYS AND GOODS IN PRECIOUS METALS OR COATED THEREWITH, NOT INCLUDED IN OTHER CLASSES, NAMELY, JEWELRY AND PRECIOUS STONES; HOROLOGICAL AND CHRONOMETRIC INSTRUMENTS (U.S. CLS. 2, 27, 28 AND 50).

CLASS 25—CLOTHING

FOR CLOTHING, NAMELY, SHIRTS, PANTS, JEANS, JACKETS, SKIRTS AND DRESSES, TEE SHIRTS, UNDERWEAR, CORSETS AND HATS; FOOTWEAR NOT INCLUDING CHILDREN'S SHOES AND SNEAKERS (U.S. CLS. 22 AND 39).

NAPOLEON SHARMA, EXAMINING ATTORNEY

SN 79-080,236. DAKTILIDIS, NIKOLAOS, GREECE, FILED 11-12-2009.



OWNER OF INTERNATIONAL REGISTRATION 1032326 DATED 11-12-2009, EXPIRES 11-12-2019.

THE MARK CONSISTS OF THE WORDING "CAVO PARADISO" WITH A DESIGN OF A STYLIZED FISH WEARING HEADPHONES, WITH BUBBLES TO ITS UPPER RIGHT.

THE ENGLISH TRANSLATION OF "CAVO PARADISO" IN THE MARK IS "PARADISE BAY".

CLASS 41—EDUCATION AND ENTERTAINMENT

FOR ENTERTAINMENT SERVICES, NAMELY, DISCOTHEQUE SERVICES, NIGHT CLUB SERVICES, LIVE MUSICAL PERFORMANCES, DJ COMPETITIONS (U.S. CLS. 100, 101 AND 107).

CLASS 43—HOTEL AND RESTAURANT SERVICES

FOR SERVICES FOR PROVIDING FOOD AND DRINK, NAMELY, BAR, CAFE (U.S. CLS. 100 AND 101).
JAMES A. RAUEN, EXAMINING ATTORNEY

SN 79-081,557. H-FARM S.P.A., ITALY, FILED 4-8-2010.

THOUNDS

THE MARK CONSISTS OF STANDARD CHARACTERS WITHOUT CLAIM TO ANY PARTICULAR FONT, STYLE, SIZE, OR COLOR.

PRIORITY DATE OF 12-22-2009 IS CLAIMED.
OWNER OF INTERNATIONAL REGISTRATION 1035927 DATED 4-8-2010, EXPIRES 4-8-2020.

THE WORDING "THOUNDS" IN THE MARK DOES NOT HAVE A MEANING IN A FOREIGN LANGUAGE.

CLASS 38—COMMUNICATION

FOR TELECOMMUNICATIONS, NAMELY, AUDIO AND VIDEO BROADCASTING SERVICES OVER THE INTERNET, AUDIO BROADCASTING, AUDIO TELECONFERENCING, BROADBAND RADIO COMMUNICATION SERVICES, BROADCAST COMMUNICATION SERVICES, NAMELY, TRANSMITTING E-MAILS, FAXES, TEXT MESSAGES AND TELEPHONE VOICE MESSAGES TO DESIGNATED RECIPIENTS FOR OTHERS, BROADCASTING OF RADIO AND TELEVISION PROGRAMMES, BROADCASTING OF VIDEO AND AUDIO PROGRAMMING OVER THE INTERNET, CHAT ROOM SERVICES FOR SOCIAL NETWORKING, VIDEO ON DEMAND TRANSMISSIONS, VIDEO BROADCASTING SERVICES OVER THE INTERNET OR OTHER COMMUNICATIONS NETWORK, NAMELY, ELECTRONICALLY TRANSMITTING VIDEO CLIPS, VIDEO BROADCASTING SERVICES OVER THE INTERNET OR OTHER COMMUNICATIONS NETWORK FEATURING THE UPLOADED, POSTED AND TAGGED VIDEOS OF OTHERS, VIDEO BROADCASTING SERVICES VIA THE INTERNET, WEB CASTING SERVICES, WEB CONFERENCING SERVICES, WEB MESSAGING, CHATROOM SERVICES FOR SOCIAL NETWORKING, PROVIDING ONLINE FORUMS IN THE NATURE OF CHAT ROOMS FOR SOCIAL NETWORKING (U.S. CLS. 100, 101 AND 104).

CLASS 41—EDUCATION AND ENTERTAINMENT

FOR EDUCATION SERVICES, NAMELY, ART EXHIBITIONS, AUDIO AND VIDEO RECORDING SERVICES, COMPUTER EDUCATION TRAINING, CONCERT BOOKING, DIGITAL VIDEO, AUDIO, AND MULTIMEDIA PUBLISHING SERVICES, DISCOTHEQUES, EDUCATION SERVICES, NAMELY, PROVIDING CLASSES, SEMINARS AND WORKSHOPS IN THE FIELD OF ENGINEERING, INTERACTION DESIGN, GRAPHIC DESIGN AND MUSIC; PROVIDING OF TRAINING, NAMELY, COMPUTER EDUCATION TRAINING, MUSIC INSTRUMENTS TRAINING, GENERAL MUSIC TRAINING; ENTERTAINMENT SERVICES IN THE NATURE OF LIVE MUSIC CONCERT, LIVE MUSIC PERFORMANCES BY A MUSICAL GROUP, ART PERFORMANCES IN THE NATURE OF THEATRICAL AND MUSICAL FLOOR SHOWS PROVIDED AT PERFORMANCE VENUES, ENTERTAINMENT IN THE NATURE OF ORCHESTRA PERFORMANCES; ORGANIZING COMMUNITY SPORTING AND CULTURAL ACTIVITIES (U.S. CLS. 100, 101 AND 107).

CLASS 45—PERSONAL AND LEGAL SERVICES

FOR LEGAL SERVICES; SECURITY GUARD SERVICES FOR THE PROTECTION OR PROPERTY AND INDIVIDUALS PERSONAL AND SOCIAL SERVICES RENDERED BY OTHERS TO MEET THE NEEDS OF INDIVIDUALS, NAMELY, DATING SERVICES PROVIDED THROUGH SOCIAL NETWORKING, CONCIERGE SERVICES FOR OTHERS COMPRISING MAKING REQUESTED PERSONAL ARRANGEMENTS AND RESERVATIONS AND PROVIDING CUSTOMER-SPECIFIC INFORMATION TO MEET INDIVIDUAL NEEDS RENDERED TOGETHER IN A APARTMENT COMPLEX, BUSINESS CONFERENCE, SHOPPING CENTER; CONSULTING IN THE FIELD OF PERSONAL RELATIONSHIPS, CONSULTING IN THE FIELD OF INTELLECTUAL PROPERTY LICENSING, CONSULTING SERVICES IN THE FIELD OF MAINTAINING THE SECURITY AND INTEGRITY OF DATABASES, DATING SERVICES (U.S. CLS. 100 AND 101).

CHARISMA HAMPTON, EXAMINING ATTORNEY

SN 79-081,939. EDUCINVEST, BELGIUM, FILED 3-4-2010.

Supinfo

OWNER OF INTERNATIONAL REGISTRATION 0968429
DATED 1-3-2008, EXPIRES 1-3-2018.

CLASS 16—PAPER GOODS AND PRINTED MATTER

FOR PAPER, CARDBOARD; BOOKBINDING MATERIAL; PHOTOGRAPHS, STATIONERY; ADHESIVES FOR STATIONERY OR HOUSEHOLD PURPOSES; PAINTBRUSHES; TYPEWRITERS; PLASTIC MATERIALS FOR PACKAGING, NAMELY, BAGS, SACHETS; PRINTERS' TYPE; PRINTING BLOCKS (U.S. CLS. 2, 5, 22, 23, 29, 37, 38 AND 50).

CLASS 38—COMMUNICATION

FOR COMMUNICATIONS BY COMPUTER TERMINALS (U.S. CLS. 100, 101 AND 104).

CLASS 41—EDUCATION AND ENTERTAINMENT

FOR PUBLICATION OF BOOKS; LENDING LIBRARIES; FILM PRODUCTION; RENTAL AND DISTRIBUTION OF FILMS; ARRANGING OF COMPETITIONS IN THE FIELD OF EDUCATION OR ENTERTAINMENT; ORGANISATION OF EXHIBITIONS FOR CULTURAL OR EDUCATIONAL PURPOSES; BOOKING OF SEATS FOR SHOWS (U.S. CLS. 100, 101 AND 107).

CLASS 42—SCIENTIFIC AND COMPUTER SERVICES

FOR SCIENTIFIC RESEARCH; COMPUTER PROGRAMMING (U.S. CLS. 100 AND 101).
YAT SYE, LEE, EXAMINING ATTORNEY

SN 79-082,093. FR L'OSTERIA GMBH, NÜRNBERG, FED REP GERMANY, FILED 11-16-2009.



OWNER OF INTERNATIONAL REGISTRATION 1037346
DATED 11-16-2009, EXPIRES 11-16-2019.

NO CLAIM IS MADE TO THE EXCLUSIVE RIGHT TO USE "L'OSTERIA" AND "PIZZA E PASTA", APART FROM THE MARK AS SHOWN.

THE COLOR(S) RED, GOLD, WHITE IS/ARE CLAIMED AS A FEATURE OF THE MARK.

THE COLOR RED APPEARS IN THE BANNER BACKGROUND AND THE COLOR GOLD APPEARS AS AN INSIDE BORDER AND THE BANNER HAS THE WHITE WORDING "L'OSTERIA". THE GOLD WORDING "PIZZA E PASTA" APPEARS BELOW THE BANNER.

THE ENGLISH TRANSLATION OF "L'OSTERIA" IN THE MARK IS TAVERN/RESTAURANT AND THE "E" MEANS AND.

CLASS 30—STAPLE FOODS

FOR PASTRIES; BREAD; ICE CREAM; PREPARATIONS MADE FROM CEREALS, NAMELY, CEREAL BASED SNACK FOOD; SPICES; COFFEE; CONFECTIONERY, NAMELY, FROZEN CONFECTIONERY AND CANDIES; CAKES; MACARONI; FARINACEOUS FOOD PASTES FOR HUMAN CONSUMPTION, NOODLES; PASTA; PIZZAS; DRESSINGS FOR SALAD, SANDWICHES; SAUCES; SPICES; SPAGHETTI; EDIBLE ICES, CONFECTIONS, NAMELY, CANDY; PASTA (U.S. CL. 46).

CLASS 35—ADVERTISING AND BUSINESS

FOR BUSINESS MANAGEMENT AND ORGANIZATION CONSULTANCY SERVICES; BUSINESS CONSULTANCY, NAMELY, BUSINESS ADVISORY SERVICES; ADVERTISING AGENCY SERVICES; BUSINESS MANAGEMENT FOR OTHERS; PUBLICATION OF PUBLICITY TEXTS; ASSISTANCE TO COMMERCIAL OR INDUSTRIAL FIRMS IN THE CONDUCT OF THEIR BUSINESS, NAMELY, PROVIDING OFFICE FUNCTIONS; BUSINESS INFORMATION SERVICES IN THE FIELD OF FRANCHISING; MARKETING RESEARCH; MARKET RESEARCH; AND PUBLIC RELATIONS; ORGANIZATION AND ARRANGING OF ADVERTISING EVENTS, NAMELY, ARRANGING AND CONDUCTING ADVERTISING CAMPAIGNS IN THE NATURE OF PROMOTING THE GOODS AND SERVICES OF OTHERS VIA A GLOBAL COMPUTER NETWORK IN THE FIELD OF FRANCHISING; BUSINESS ORGANIZATIONAL CONSULTANCY; PLANNING AND BUSINESS DEVELOPMENT CONSULTING SERVICES, NAMELY, MONITORING OF BUSINESS DEVELOPMENTS WITH REGARD TO ORGANIZATIONAL MATTERS; PLANNING OF ADVERTISING INITIATIVES, NAMELY, ARRANGING AND CONDUCTING ADVERTISING CAMPAIGNS IN THE NATURE OF PROMOTING THE GOODS AND SERVICES OF OTHERS VIA A GLOBAL COMPUTER NETWORK IN THE FIELD OF FRANCHISING; PRESENTATION OF COMPANIES ON THE INTERNET AND OTHER MEDIA, NAMELY, INTERNET PRESENTATION OF RESTAURANTS AND OTHER GASTRONOMICAL SERVICES, NAMELY, ON-LINE BUSINESS DIRECTORIES FEATURING RESTAURANTS AND OTHER GASTRONOMICAL SERVICES; GOOD AND SERVICE PRESENTATION, NAMELY, PROVIDING AN ON-LINE DIRECTORY INFORMATION SERVICE FEATURING INFORMATION REGARDING RESTAURANTS; ADVERTISING (U.S. CLS. 100, 101 AND 102).

CLASS 43—HOTEL AND RESTAURANT SERVICES

FOR BARS; OUTSIDE CATERING; CAFÉS; RESTAURANTS; RESTAURANT SERVICES (U.S. CLS. 100 AND 101).

RAMONA ORTIGA, EXAMINING ATTORNEY

SN 79-082,714. LAURIE ROBERTSON, UNITED KINGDOM, FILED 1-25-2010.



PRIORITY DATE OF 1-7-2010 IS CLAIMED.
OWNER OF INTERNATIONAL REGISTRATION 1039137
DATED 1-25-2010, EXPIRES 1-25-2020.

THE MARK CONSISTS OF THE WORDING "ANORAK" IN STYLIZED FONT, WITH THE CAPITAL LETTER "A" AND THE LETTERS "N", "O", "R", "A", "K" IN LOWER CASE, SURROUNDED BY AN OVAL FRAME.

CLASS 18—LEATHER GOODS

FOR BABY CARRYING BAGS, NAMELY, SLING BAGS FOR CARRYING INFANTS, BAGS WITH HARNESS FOR CARRYING INFANTS, SADDLEBAGS, CARRY-ALL BAGS USED FOR CAMPERS, ALL-PURPOSE SPORTS BAGS, BEACH BAGS, BEACH UMBRELLAS, ALL-PURPOSE BAGS USED BY CAMPERS, CASES THAT ARE NOT FITTED OR SHAPED FOR SPORTING ARTICLES, NAMELY, BAGS AND HOLD-ALLS FOR SPORTS CLOTHING, CARRIER BAGS, NAMELY, CARRIERS FOR SUITS, SHIRTS AND DRESSES, UNFITTED TRAVEL CASES, COMBINATION WALKING STICKS AND UMBRELLAS, DUFFEL BAGS, DIARY COVERS THAT ARE NOT ADAPTED, NAMELY, FLIGHT BAGS, GARDENING BAGS, NAMELY, ALL PURPOSE BAGS USED BY GARDENERS, HANDBAGS, JEWELRY ROLLS FOR TRAVEL, KEY CASES, LUGGAGE, LUGGAGE LABEL HOLDERS, MAKE-UP BAGS SOLD EMPTY, MAKE-UP CASES SOLD EMPTY, MOUNTAINEERING STICKS, NIGHTWEAR CASES, NAMELY, OVERNIGHT CASES, NOTE CASES, NAMELY, ATTACHE CASES, CARRYING CASES FOR DOCUMENTS, OVERNIGHT BAGS, OVERNIGHT CASES, BRIEFCASE-TYPE PORTFOLIOS, RUCKSACKS, SHOULDER BAGS, SPORT BAGS, OTHER THAN ADAPTED OR SHAPED TO CONTAIN SPECIFIC SPORTS APPARATUS, SPORTS BAGS, OTHER THAN SHAPED TO CONTAIN SPECIFIC APPARATUS USED IN PLAYING SPORTS, SUIT CARRIERS BEING TRAVELLING BAGS, SUNSHADES BEING PORTABLE, NAMELY, SUNSHADE PARASOLS, SUNSHADES IN THE NATURE OF UMBRELLAS, TOILETRY BAGS SOLD EMPTY, TOILETRY BAGS SOLD EMPTY, TRAVEL GARMENT COVERS, NAMELY, GARMENT BAGS FOR TRAVEL, TRAVELLING BAGS, UMBRELLAS, WAIST BAGS, WAIST POUCHES, WALKING-STICK SEATS, WALLET, WEEKEND BAGS, NAMELY, OVERNIGHT BAGS (U.S. CLS. 1, 2, 3, 22 AND 41).

CLASS 20—FURNITURE AND ARTICLES NOT OTHERWISE CLASSIFIED

FOR AIR CUSHIONS, NAMELY, PLASTIC CUSHIONING MATERIAL THAT CONTAINS ENCAPSULATED AIR CELLS, OTHER THAN FOR MEDICAL PURPOSES, INFLATABLE SLEEPING BAGS, AIR MATTRESSES BEING INFLATABLE FOR USE WHEN CAMPING, INFLATABLE PILLOWS, OTHER THAN FOR MEDICAL PURPOSES, ARTICLES MADE FROM PLASTIC MATERIALS, NAMELY, CAMPING EQUIPMENT, FURNITURE, PILLOWS OTHER THAN FOR MEDICAL PURPOSES, MATTRESSES AND SLEEPING BAGS, FITTED BAGS FOR SLEEPING BAGS SPECIFICALLY ADAPTED, BEACH CHAIRS, CAMPING FURNITURE, DECK CHAIRS, DECORATIONS OF PLASTIC MATERIALS FOR USE OF FESTIVE OCCASIONS, NAMELY, DECORATIONS OF PLASTIC FOR FOODSTUFF, GIFT PACKAGE DECORATIONS MADE OF PLASTIC, OUTDOOR HOLIDAY DECORATIONS MADE OF CLEAR OR TRANSLUCENT PVC OR POLYPROPYLENE DIE CUT FORMS HAVING HOLIDAY THEMED SHAPES AND ICONS, LAWN FURNITURE, INFLATABLE NECK SUPPORT CUSHIONS, OTHER THAN FOR MEDICAL PURPOSES, INFLATABLE FURNITURE, INFLATABLE PILLOWS OTHER THAN FOR MEDICAL USE FOR FITTING AROUND THE NECK, MATTRESSES FOR USE ON BEACHES, NAMELY, AIR MATTRESSES FOR USE WHEN CAMPING, MIRRORS FOR USE WHEN TRAVELLING, NAMELY, HAND-HELD MIRRORS, PILLOWS OTHER THAN FOR MEDICAL USE FOR FITTING AROUND THE NECK, PAPER BINS, NAMELY, NON-METAL BINS, PATIO FURNITURE, NON-METAL TENT PEGS, PICNIC BENCHES, PICNIC TABLES, PICNIC FURNITURE, NAMELY, FURNITURE FOR CAMPING, PORTABLE BEDS FOR PETS, PORTABLE BOXES AND CONTAINERS MADE OF PLASTIC, NAMELY, PACKAGING CONTAINERS OF PLASTIC, SEATS FOR CHILDREN, NAMELY, HIGH CHAIRS FOR BABIES, SLEEPING BAGS, SLEEPING MATS FOR CAMPING, STORING BOXES, NOT OF METAL, NAMELY, PLASTIC STORAGE BOXES, SUN LOUNGERS, NAMELY, LOUNGE CHAIRS, FURNITURE BEING INDOOR SUN

SCREENS NOT OF METAL OR TEXTILE, FURNITURE BEING PORTABLE OUTDOOR PRIVACY SCREENS, TABLES FOR USE IN GARDENS, FITTED TEXTILE COVERS FOR FURNITURE, TOY BOXES AND CHESTS, COMMERCIAL PACKAGING MATERIALS, NAMELY, CORRUGATED PLASTIC TRAYS AND THERMOFORMED PLASTIC TRAYS, TOOLS ACCESSORY STRAYS NOT MADE OF METAL SOLD EMPTY AND PARTS AND FITTINGS THEREOF, GLASS SURFACE FOR TABLES, SLEEPING BAGS FOR CAMPING (U.S. CLS. 2, 13, 22, 25, 32 AND 50).

CLASS 21—HOUSEWARES AND GLASS

FOR MUGS MADE OF CERAMIC, CHINA, DECORATED CHINA, POTTERY, EARTHENWARE AND PORCELAIN, PAPER AND PLASTIC CUPS, PLASTIC CONTAINERS FOR DOMESTIC USE AND INSULATED CONTAINERS FOR FOOD OR BEVERAGES FOR DOMESTIC USE, DRINKING CUPS, DRINKING FLASKS, FLASKS, GARDENING GLOVES, LUNCH BOXES, LUNCHEON BOXES, FITTED PICNIC BASKETS, LUNCH BOXES, CROCKERY FOR OUTDOOR USE, NAMELY, POYKE, PICNIC UTENSILS, NAMELY, UTENSILS FOR BARBECUES, NAMELY, FORKS, TONGS, TURNERS, PICNIC WARE, NAMELY, DISPOSABLE TABLE PLATES, DISPOSABLE DINNERWARE, NAMELY, PLATES, BOWLS AND SERVING TRAYS, PORTABLE COOKING KITS FOR OUTDOOR USE, PLASTICS TRAYS FOR DOMESTIC USE, NAMELY, TRAYS FOR DOMESTIC PURPOSES, NOT MADE OF METAL, PLATES, PLATES BEING DISHES, ALL-PURPOSE PORTABLE CONTAINERS FOR BEVERAGES FOR HOUSEHOLD OR KITCHEN USE, ALL-PURPOSE PORTABLE CONTAINERS FOR HOUSEHOLD USE, NON-ELECTRIC PORTABLE CHILLED BEVERAGE DISPENSERS, EARTHENWARE MUGS AND PLATES, BEVERAGE GLASSWARE, TEA SETS, WIPING CLOTH FOR HOUSEHOLD USE, NAMELY, CLEANING CLOTH, PICNIC BASKETS SOLD EMPTY (U.S. CLS. 2, 13, 23, 29, 30, 33, 40 AND 50).

CLASS 22—CORDAGE AND FIBERS

FOR AWNINGS FOR TENTS, AWNINGS OF TEXTILE, WAVY FIBER TEXTILES, TENTS, AWNINGS FOR CARAVANS, TENTS FOR CAMPING, TENTS FOR MOUNTAINEERING, TENTS FOR USE AS AN ADJUNCT TO VEHICLES, TENTS MADE OF TEXTILE MATERIALS, LAUNDRY BAGS AND LAUNDRY WASH BAGS (U.S. CLS. 1, 2, 7, 19, 22, 42 AND 50).

CLASS 24—FABRICS

FOR BATH LINEN EXCEPT CLOTHING, BATH TOWELS, BATHROOM FURNISHINGS OF TEXTILE, NAMELY, TEXTILES USED TO DECORATE BATHROOMS, BATHROOM LINEN, BEACH TOWELS, UNFITTED FURNITURE COVERS NOT OF PAPER AND USED ON BEAN BAGS, BED BLANKETS, BED COVERS, BED LINEN, BED QUILTS, BED SHEETS, FABRIC BED VALANCES, BEDROOM TEXTILE FABRICS, NAMELY, FABRICS USED TO DECORATE BEDROOMS, BEDSPREADS, COATED TEXTILES, NAMELY, TEXTILES WITH A COATING APPLIED TO THEM, COTTON FABRICS, UNFITTED FURNITURE COVERS OF TEXTILE, CURTAINS FOR WINDOWS, DINNER MATS OF PLASTICS MATERIAL, NAMELY, PLASTIC PLACE MAT, TEXTILE DINNER NAPKINS, DISH MATS, NAMELY, PLASTIC PLACE MATS, NON-PAPER DOILIES OF TEXTILE, CURTAINS OF TEXTILE OF OVER DOORS, FABRICS FOR TEXTILE USE, FACE CLOTHS OF TEXTILE, FACE CLOTHS OF TOWELLING, FACE FLANNELS IN THE FORM OF GLOVES, NAMELY, WASHING GLOVES, FACE TOWELS OF TEXTILE, FLOCKED FABRICS, NAMELY, FABRICS WITH SMALL TUFTS OF WOOL OR SIMILAR MATERIAL APPLIED TO THE FABRIC TO GIVE A RAISED PATTERN, FURNISHING FABRICS, FURNISHING FABRICS BEING TEXTILE PIECE GOODS, HAND TOWELS OF TEXTILE, HOUSEHOLD CLOTHS FOR DRYING DISHES, NAMELY, DISH CLOTH, HOUSEHOLD DISH CLOTH CLOTHES FOR DRYING GLASSES, TEXTILE FABRICS FOR USE IN MAKING CLOTHING AND HOUSEHOLD FURNISHINGS, KITCHEN LINEN, KITCHEN TOWELS OF TEXTILE, MATERIALS FOR SOFT FURNISHINGS, NAMELY, MATERIALS USED

TO DECORATE ROOMS, MATERIALS FOR UPHOLSTERY, NAMELY, MATERIALS USED TO COVER FURNITURE, MOQUETTES, NAMELY, CURTAINS, MOQUETTES, NAMELY, FABRIC CURTAINS, PILLOW-CASES, PILLOW COVERS, PLASTIC PLACE MATS, PRINTED FABRICS, NAMELY, FABRICS WITH PATTERNS PRINTED ON THEM, PRINTED TEXTILE PIECE GOODS, TEXTILE GOODS WITH PATTERNS PRINTED ON THEM, PYJAMA CASES, NAMELY, CASES FOR STORING PYJAMAS, QUILT COVERS, QUILTED BLANKETS FOR BEDDING, QUILTED TEXTILE ARTICLES OTHER THAN FOR INSULATION), NAMELY, ARTICLES OF TEXTILES FORMED BY COMBINING SEVERAL DIFFERENT TYPES OF TEXTILES, QUILTS, SHOWER CURTAINS, CURTAINS OF TEXTILE TABLE CLOTHS NOT OF PAPER, TABLE CLOTHS FOR HYGIENIC PURPOSES MADE OF NON-WOVEN MATERIALS, TABLE LINEN NOT OF PAPER, TABLE MATS NOT OF PAPER, TABLE MATS MADE OF TEXTILE MATERIALS, TABLE NAPKINS OF TEXTILE, TABLE PLACE SETTING MATS OF TEXTILE, FABRIC TABLE RUNNERS, TEA TOWELS, TEXTILE USED FOR DECORATING ROOMS, TABLES, BATHROOMS, FOR COVERING DUVETS AND AS BEDDING, TEXTILE HANDKERCHIEFS, TEXTILE NAPKINS BEING TABLE LINEN, TEXTILE BED SHEETS, TRAVELING BLANKETS, RUGS OR BLANKETS USED TO COVER LEGS, WHILST TRAVELING OR OTHERWISE, PLASTIC TABLE COVERS TO PREVENT DAMAGE FROM HOT DISHES, PLASTIC TABLE COVERS TO PROTECT THE SURFACE FROM SCRATCHING, DISH CLOTHS OF TEXTILE FOR DRYING, TABLE MATS OF PRECIOUS METAL, PLASTIC PLACE MATS, PORCELAIN PLACE MATS (U.S. CLS. 42 AND 50).

NAPOLÉON SHARMA, EXAMINING ATTORNEY

CLASS 16—PAPER GOODS AND PRINTED MATTER

FOR PRINTED MATTER AND PUBLICATIONS, NAMELY, BOOKS, HAND-OUTS, BOOKLETS, PAMPHLETS, BROCHURES, NEWSLETTERS, JOURNALS, AND MAGAZINES IN THE FIELDS OF FINANCE, BUSINESS, MARKET RESEARCH, MARKET ANALYSIS, INVESTMENT, SCIENCE, TECHNOLOGY AND BIOTECHNOLOGY; PRINTED PERIODICALS IN THE FIELDS OF FINANCE, BUSINESS, MARKET RESEARCH, MARKET ANALYSIS, INVESTMENT, SCIENCE, TECHNOLOGY AND BIOTECHNOLOGY; CATALOGUES IN THE FIELDS OF FINANCE, BUSINESS, MARKET RESEARCH, MARKET ANALYSIS, INVESTMENT, SCIENCE, TECHNOLOGY AND BIOTECHNOLOGY; PRINTED PROSPECTUSES IN THE FIELDS OF FINANCE, BUSINESS, MARKET RESEARCH, MARKET ANALYSIS, INVESTMENT, SCIENCE, TECHNOLOGY AND BIOTECHNOLOGY; POSTERS; CALENDARS; STICKERS; PRINTED PAPER SIGNS; BANNERS OF PAPER AND CARDBOARD; MAGAZINES IN THE FIELDS OF FINANCE, BUSINESS, MARKET RESEARCH, MARKET ANALYSIS, INVESTMENT, SCIENCE, TECHNOLOGY AND BIOTECHNOLOGY; BOOKLETS IN THE FIELDS OF FINANCE, BUSINESS, MARKET RESEARCH, MARKET ANALYSIS, INVESTMENT, SCIENCE, TECHNOLOGY AND BIOTECHNOLOGY; PAMPHLETS IN THE FIELDS OF FINANCE, BUSINESS, MARKET RESEARCH, MARKET ANALYSIS, INVESTMENT, SCIENCE, TECHNOLOGY AND BIOTECHNOLOGY; PRINTED FORMS; DIAGRAMS FOR CHARTING FINANCIAL INVESTMENTS; NEWSLETTERS IN THE FIELDS OF FINANCE, BUSINESS, MARKET RESEARCH, MARKET ANALYSIS, INVESTMENT, SCIENCE, TECHNOLOGY AND BIOTECHNOLOGY; PRINTED PUBLICATIONS RELATING TO FINANCIAL SERVICES; CARDBOARD AND CARDBOARD ARTICLES NAMELY, ADVERTISING SIGNS OF PAPER OR CARDBOARD; INSTRUCTIONAL AND TEACHING MATERIALS, NAMELY, BOOKS, HAND-OUTS, AND BOOKLETS IN THE FIELDS OF FINANCE, BUSINESS, MARKET RESEARCH, MARKET ANALYSIS, INVESTMENT, SCIENCE, TECHNOLOGY AND BIOTECHNOLOGY (U.S. CLS. 2, 5, 22, 23, 29, 37, 38 AND 50).

SN 79-085,877. EDISON INVESTMENT RESEARCH LIMITED, UNITED KINGDOM, FILED 4-27-2010.

EDISON INVESTMENT RESEARCH

THE MARK CONSISTS OF STANDARD CHARACTERS WITHOUT CLAIM TO ANY PARTICULAR FONT, STYLE, SIZE, OR COLOR.

PRIORITY DATE OF 3-23-2010 IS CLAIMED.

OWNER OF INTERNATIONAL REGISTRATION 1047109 DATED 4-27-2010, EXPIRES 4-27-2020.

NO CLAIM IS MADE TO THE EXCLUSIVE RIGHT TO USE "INVESTMENT RESEARCH", APART FROM THE MARK AS SHOWN.

CLASS 35—ADVERTISING AND BUSINESS

FOR BUSINESS ADMINISTRATION SERVICES; BUSINESS CONSULTING, NAMELY, BUSINESS DATA ANALYSIS; INFORMATION AND DATA COMPILING AND ANALYZING RELATING TO BUSINESS MANAGEMENT; DATA PROCESSING SERVICES; PROVISION OF BUSINESS INFORMATION; BUSINESS INVESTIGATIONS; BUSINESS CONSULTANCY; PROVISION OF ONLINE BUSINESS AND COMMERCIAL INFORMATION IN THE FIELDS OF FINANCE, BUSINESS, MARKET RESEARCH AND MARKET ANALYSIS FOR INVESTMENT PURPOSES, INVESTMENT, SCIENCE, TECHNOLOGY AND BIOTECHNOLOGY; BUSINESS MARKET RESEARCH AND MARKET ANALYSIS IN THE FIELDS OF INVESTMENT, SCIENCE, TECHNOLOGY AND BIOTECHNOLOGY; BUSINESS RESEARCH; MARKET RESEARCH AND MARKET ANALYSIS FOR INVESTMENT PURPOSES; PREPARATION OF BUSINESS REPORTS; PROVIDING MARKET ANALYSIS REPORTS; COMPILATION AND PROVISION OF BUSINESS INFORMATION; BUSINESS ACQUISITION AND MERGER CONSULTATION; SYSTEMIZATION AND COMPILATION OF BUSINESS INFORMATION, DATA, STATISTICS AND INDICES INTO COMPUTER DATABASE; COMPILATION OF BUSINESS STATISTICS AND COMMERCIAL INFORMATION IN THE FIELDS OF FINANCE, BUSINESS, MARKET RESEARCH AND MARKET ANALYSIS FOR INVESTMENT PURPOSES, INVESTMENT, SCIENCE, TECHNOLOGY AND BIOTECHNOLOGY; PROVISION OF BUSINESS INFORMATION RELATING TO JOINT VENTURES; ADVISORY SERVICES RELATING TO BUSINESS ACQUISITIONS; CONSULTATIONS RELATING TO BUSINESS ACQUISITIONS; ADVISORY SERVICES RELATING TO BUSINESS RISK MANAGEMENT; INFORMATION AND EXPERT OPINIONS RELATING TO COMPANIES AND BUSINESS; BUSINESS ADVISORY SERVICES, CONSULTANCY AND INFORMATION; ECONOMIC FORECASTING, IN PARTICULAR, AS REGARDS FINANCIAL MATTERS; ALL OF THE AFOREMENTIONED MARKET

RESEARCH AND MARKET ANALYSIS SERVICES EXCLUDE CONSUMER SURVEYS AND MARKETING POLLS (U.S. CLS. 100, 101 AND 102).

CLASS 36—INSURANCE AND FINANCIAL

FOR PROVISION OF FINANCIAL INFORMATION; FINANCIAL SERVICES, NAMELY, FINANCIAL ANALYSIS, FINANCE RESEARCH; GLOBAL INVESTMENT RESEARCH CONCERNING FINANCIAL INFORMATION AND FINANCIAL STATISTICS ABOUT COMPANIES PROVIDED TO CUSTOMERS TO ASSIST IN INVESTMENT DECISIONS; ANALYSIS OF FINANCIAL DATA OF COMPANIES AND MEASUREMENT OF FINANCIAL PERFORMANCE OF SUCH COMPANIES; PROVIDES FINANCIAL INFORMATION ABOUT COMPANIES TO ENABLE POTENTIAL INVESTORS TO DETERMINE WHETHER TO MAKE AN INVESTMENT IN SUCH COMPANIES; PROVIDES CLIENT COMPANIES WITH FINANCIAL INFORMATION AND INVESTMENT STATISTICS AS TO INVESTORS CONSIDERING INVESTING IN THOSE COMPANIES; FINANCE RESEARCH; INVESTMENT RESEARCH; ALL OF THE AFOREMENTIONED SERVICES EXCLUDE SERVICES RELATING TO PHILANTHROPIC AND/OR CHARITABLE FUNDRAISING ACTIVITIES (U.S. CLS. 100, 101 AND 102).

CLASS 41—EDUCATION AND ENTERTAINMENT

FOR EDUCATIONAL SERVICES, NAMELY, COURSES, WORKSHOPS, AND SEMINARS IN THE FIELDS OF FINANCE, BUSINESS, MARKET RESEARCH, MARKET ANALYSIS, INVESTMENT, SCIENCE, TECHNOLOGY AND BIOTECHNOLOGY; PROVIDING ONLINE NON-DOWNLOADABLE ELECTRONIC PUBLICATIONS, NAMELY, ARTICLES, BOOKS, MAGAZINES, AND BROCHURES IN THE FIELDS OF FINANCE, BUSINESS, MARKET RESEARCH, MARKET ANALYSIS, INVESTMENT, SCIENCE, TECHNOLOGY AND BIOTECHNOLOGY; ARRANGING AND CONDUCTING OF EDUCATIONAL BUSINESS CONFERENCES FOR COMPANIES AND POTENTIAL INVESTORS IN SUCH COMPANIES TO PROVIDE RELEVANT INVESTMENT INFORMATION AND SEMINARS IN THE FIELDS OF FINANCE, BUSINESS, MARKET RESEARCH, MARKET ANALYSIS, INVESTMENT, SCIENCE, TECHNOLOGY AND BIOTECHNOLOGY (U.S. CLS. 100, 101 AND 107).

CLASS 42—SCIENTIFIC AND COMPUTER SERVICES

FOR SCIENTIFIC AND TECHNOLOGICAL SERVICES, NAMELY, SCIENTIFIC RESEARCH, ANALYSIS, AND TESTING IN THE FIELDS OF FINANCE, BUSINESS, MARKET RESEARCH, MARKET ANALYSIS, INVESTMENT, SCIENCE, TECHNOLOGY AND BIOTECHNOLOGY WITH RESPECT TO INFORMATION ABOUT AND THE MERITS OF INDIVIDUAL TECHNOLOGICAL AND SCIENTIFIC PROGRAMS OF COMPANIES WHEN SUCH PROGRAMS ARE RELEVANT FOR INVESTMENT DECISIONS; SCIENTIFIC RESEARCH; SCIENTIFIC ANALYSIS IN THE FIELD OF FINANCE, BUSINESS, MARKET RESEARCH AND MARKET ANALYSIS; SCIENTIFIC TESTING IN THE FIELDS OF FINANCE, BUSINESS, MARKET RESEARCH, MARKET ANALYSIS, INVESTMENT, SCIENCE, TECHNOLOGY, AND BIOTECHNOLOGY WITH RESPECT TO INFORMATION ABOUT AND THE MERITS OF INDIVIDUAL TECHNOLOGICAL AND SCIENTIFIC PROGRAMS OF COMPANIES WHEN SUCH PROGRAMS ARE RELEVANT FOR INVESTMENT DECISIONS; SCIENTIFIC REPORTING, NAMELY, PROVIDING SCIENTIFIC INFORMATION REGARDING FINANCE, BUSINESS, MARKET RESEARCH, MARKET ANALYSIS, AND INVESTMENT; TECHNOLOGICAL RESEARCH, TECHNOLOGICAL ANALYSIS, AND TECHNOLOGICAL TESTING WITH RESPECT TO INFORMATION ABOUT AND THE MERITS OF INDIVIDUAL TECHNOLOGICAL AND SCIENTIFIC PROGRAMS OF COMPANIES WHEN SUCH PROGRAMS ARE RELEVANT FOR INVESTMENT DECISIONS; TECHNOLOGICAL REPORTING IN THE NATURE OF PROVIDING SCIENTIFIC INFORMATION INVOLVING TECHNOLOGICAL PROGRAMS OF COM-

PANIES; SCIENTIFIC RESEARCH SERVICES; INDUSTRIAL RESEARCH SERVICES IN THE FIELDS OF FINANCE, BUSINESS, MARKET RESEARCH, MARKET ANALYSIS, INVESTMENT, SCIENCE, TECHNOLOGY AND BIOTECHNOLOGY WHEN SUCH RESEARCH IS RELEVANT FOR INVESTMENT DECISIONS; ADVISORY SERVICES RELATING TO TECHNOLOGICAL RESEARCH IN THE FIELDS OF FINANCE, BUSINESS, MARKET RESEARCH, MARKET ANALYSIS, INVESTMENT, SCIENCE, TECHNOLOGY AND BIOTECHNOLOGY WHEN SUCH TECHNOLOGICAL RESEARCH IS RELEVANT FOR INVESTMENT DECISIONS; ADVISORY SERVICES RELATING TO SCIENTIFIC RESEARCH IN THE FIELDS OF FINANCE, BUSINESS, MARKET RESEARCH, MARKET ANALYSIS, INVESTMENT, SCIENCE, TECHNOLOGY AND BIOTECHNOLOGY FOR INVESTMENT PURPOSES; PROVIDING SCIENTIFIC INFORMATION BY PREPARING SCIENTIFIC REPORTS ANALYZING SCIENTIFIC PROGRAMS FOR INVESTMENT PURPOSES; PROVIDING TECHNICAL ADVICE BY PREPARING TECHNICAL REPORTS IN THE FIELDS OF FINANCE, BUSINESS, MARKET RESEARCH, MARKET ANALYSIS, INVESTMENT, SCIENCE, TECHNOLOGY, AND BIOTECHNOLOGY FOR INVESTMENT PURPOSES; PROVIDING TECHNOLOGICAL INFORMATION BY PREPARING TECHNOLOGICAL REPORTS IN THE FIELDS OF FINANCE, BUSINESS, MARKET RESEARCH, MARKET ANALYSIS, INVESTMENT, SCIENCE, TECHNOLOGY AND BIOTECHNOLOGY FOR INVESTMENT PURPOSES; PROVIDING SCIENTIFIC INFORMATION BY PREPARING REPORTS IN THE BIOTECHNOLOGY FIELD AND REPORTS RELATING TO CHEMICAL RESEARCH; PROFESSIONAL TECHNICAL CONSULTANCY RELATING TO DATA PROCESSING, NAMELY, TECHNICAL CONSULTING SERVICES RELATED TO DEVELOPMENT OF DATA PROCESSING PROGRAMS IN THE FIELDS OF BIOTECHNOLOGY, PHARMACEUTICAL RESEARCH AND DEVELOPMENT OF GENETIC SCIENCE, AND SCIENTIFIC AND CONSULTING RESEARCH FOR INVESTMENT PURPOSES; CONSULTANCY SERVICES RELATING TO TECHNOLOGICAL RESEARCH IN THE FIELDS OF FINANCE, BUSINESS, MARKET RESEARCH, MARKET ANALYSIS, AND INVESTMENT FOR INVESTMENT PURPOSES; TECHNICAL CONSULTANCY SERVICES FOR ANALYZING INFORMATION SYSTEMS; ALL OF THE AFOREMENTIONED MARKET RESEARCH AND MARKET ANALYSIS SERVICES EXCLUDE CONSUMER SURVEYS AND MARKETING POLLS (U.S. CLS. 100 AND 101).

YAT SYE, LEE, EXAMINING ATTORNEY

SN 79-087,049. DAFOLIA MANAGEMENT B.V., NETHERLANDS, FILED 9-3-2010.

DAFOLIA

THE MARK CONSISTS OF STANDARD CHARACTERS WITHOUT CLAIM TO ANY PARTICULAR FONT, STYLE, SIZE, OR COLOR.

PRIORITY DATE OF 3-3-2010 IS CLAIMED.

OWNER OF INTERNATIONAL REGISTRATION 1050315 DATED 9-3-2010, EXPIRES 9-3-2020.

CLASS 35—ADVERTISING AND BUSINESS

FOR ADVERTISING; BUSINESS MANAGEMENT; BUSINESS ADMINISTRATION; PROVIDING OFFICE FUNCTIONS (U.S. CLS. 100, 101 AND 102).

CLASS 36—INSURANCE AND FINANCIAL

FOR FINANCIAL AFFAIRS AND MONETARY AFFAIRS, NAMELY, FINANCIAL INFORMATION, MANAGEMENT AND ANALYSIS SERVICES; REAL ESTATE AFFAIRS, NAMELY, RENTAL PROPERTY MANAGEMENT, REAL ESTATE CONSULTANCY, REAL ESTATE FINANCING SERVICES, REAL ESTATE INVESTMENT SERVICES, REAL ESTATE MANAGEMENT SERVICES, FINANCING OF REAL ESTATE DEVELOPMENT AND CONSTRUCTION PROJECTS FOR COMMERCIAL, RESIDENTIAL AND HOTEL PROPERTIES (U.S. CLS. 100, 101 AND 102).

CLASS 42—SCIENTIFIC AND COMPUTER SERVICES

FOR DESIGN AND DEVELOPMENT OF COMPUTER HARDWARE AND SOFTWARE (U.S. CLS. 100 AND 101).

CLASS 45—PERSONAL AND LEGAL SERVICES

FOR LEGAL SERVICES; PERSONAL AND SOCIAL SERVICES RENDERED BY OTHERS TO MEET THE NEEDS OF INDIVIDUALS, NAMELY, INTERNET-BASED SOCIAL NETWORKING SERVICES, CASE MANAGEMENT SERVICES, NAMELY, COORDINATION OF LEGAL, SOCIAL AND PSYCHOLOGICAL SERVICES FOR SEXUAL ORIENTATION DISCRIMINATED PERSONS, ONLINE SOCIAL NETWORKING SERVICES PROVIDED THROUGH A COMMUNITY WEBSITE, ONLINE GAY, LESBIAN AND BISEXUAL SOCIAL NETWORKING SERVICES (U.S. CLS. 100 AND 101).
RAMONA ORTIGA, EXAMINING ATTORNEY

SN 79-087,601. RHOMBERG BAU GMBH, AUSTRIA, FILED 7-19-2010.

LIFECYCLE TOWER

THE MARK CONSISTS OF STANDARD CHARACTERS WITHOUT CLAIM TO ANY PARTICULAR FONT, STYLE, SIZE, OR COLOR.

PRIORITY DATE OF 7-19-2010 IS CLAIMED.

OWNER OF INTERNATIONAL REGISTRATION 1051840 DATED 7-19-2010, EXPIRES 7-19-2020.

NO CLAIM IS MADE TO THE EXCLUSIVE RIGHT TO USE "TOWER", APART FROM THE MARK AS SHOWN.

CLASS 19—NON-METALLIC BUILDING MATERIALS

FOR BUILDING MATERIALS, NAMELY, SEMI-WORKED WOOD, WOOD BOARDS, BUILDING GLASS, CONCRETE, AND DRYWALL FOR ENERGY EFFICIENT AND ENVIRONMENTALLY CONSCIOUS BUILDINGS (U.S. CLS. 1, 12, 33 AND 50).

CLASS 36—INSURANCE AND FINANCIAL

FOR FINANCIAL INFORMATION, MANAGEMENT AND ANALYSIS RELATING TO ENERGY EFFICIENT AND ENVIRONMENTALLY CONSCIOUS BUILDINGS (U.S. CLS. 100, 101 AND 102).

CLASS 37—CONSTRUCTION AND REPAIR

FOR BUILDING CONSTRUCTION AND REPAIR, BUILDING CONSTRUCTION SUPERVISION, CONSTRUCTION OF ENERGY EFFICIENT AND ENVIRONMENTALLY CONSCIOUS BUILDINGS, REAL ESTATE DEVELOPMENT AND CONSTRUCTION OF COMMERCIAL AND RESIDENTIAL PROPERTY (U.S. CLS. 100, 103 AND 106).

JIM RINGLE, EXAMINING ATTORNEY

SN 79-087,922. ARTEMIS GIDA SANAYI VE TICARET ANONIM SIRKETI, TURKEY, FILED 3-2-2010.

CLARITA'S WAY

OWNER OF INTERNATIONAL REGISTRATION 1052668 DATED 3-2-2010, EXPIRES 3-2-2020.

CLASS 16—PAPER GOODS AND PRINTED MATTER

FOR PAPER, CARDBOARD, TOWELS OF PAPER, TABLE NAPKINS OF PAPER, TOILET PAPERS, HANDKERCHIEFS OF PAPER, BABIES' DIAPERS OF PAPER AND CELLULOSE; BIBS OF PAPER, TABLE CLOTHS OF PAPER, PAPER PLACEMATS, AND PAPER MATS FOR GLASSES AND PLATES; VIGNETTING APPARATUS OF PAPER, WRAPPERS, NAMELY, BOTTLE WRAPPERS OF CARDBOARD OR PAPER, COIN WRAPPERS, FOOD WRAPPERS, BOXES OF PAPER OR CARDBOARD, PAPER OR CARDBOARD PACKINGS, PAPER BAGS; GARBAGE BAGS OF PAPER OR PLASTICS, COVERS, NAMELY, BOOK COVERS, DOCUMENT COVERS, PAPER TRAY COVERS, PLASTIC FOIL AND SHEETS FOR WRAPPING, PLASTIC FILM USED IN PRESERVING AND COOKING FOODS; PRINTING AND BINDING MATERIALS, NAMELY, BOOKBINDING MATERIALS, PRINTING TYPE, PRINTING CLICHÉS, ADHESIVES AND ADHESIVE TAPES FOR STATIONERY PURPOSES, PRINTED DOCUMENTS, NAMELY, PRINTED MATTER AND PRINTED PUBLICATIONS IN THE NATURE OF BOOKS, HAND-OUTS, WORKBOOKS IN THE FIELD OF KITCHEN, FOOD AND HEALTHY LIVING; NEWSPAPERS, MAGAZINES IN THE FIELD OF KITCHEN, FOOD AND HEALTHY LIVING; BOOKS IN THE FIELD OF KITCHEN, FOOD AND HEALTHY LIVING; BOOKS IN THE FIELD OF GUIDEBOOKS FEATURING KITCHEN, FOOD AND HEALTHY LIVING; CALENDARS, POSTERS, PICTURES, PLACARDS OF PAPER OR CARDBOARD, PHOTOGRAPHS, FRAMED OR UNFRAMED PAINTINGS, STICKERS AND SEALING STAMPS, WRITING PAPERS, STENCIL PAPERS, PARCHMENT PAPER, COPYING PAPERS, PAPERS AND ROLLS FOR WRITING AND CALCULATING MACHINES, CARDS, NAMELY, GREETING CARDS, NOTE CARDS, BUSINESS CARDS, CHRISTMAS CARDS, CORRESPONDENCE CARDS, CREDIT CARDS WITHOUT MAGNETIC CODING, BLANK CARDS, NOTEBOOKS, PAPER SHEETS, ENVELOPES; LABELS, NOT OF TEXTILE, NAMELY, ADDRESS LABELS, BARCODE LABELS, ADHESIVE LABELS, MAILING LABELS, SHIPPING LABELS; DOCUMENT FILES, ALBUMS, NAMELY, COIN ALBUMS, PHOTOGRAPH ALBUMS, STAMP ALBUMS, WEDDING ALBUMS, STICKER ALBUMS, EVENT ALBUMS; FOLDERS, COVERS FOR BOOKS AND NOTEBOOKS, MATERIALS FOR WRITING, DRAWING, PAINTING FOLDERS, COVERS FOR BOOKS AND NOTEBOOKS, MATERIALS FOR WRITING, DRAWING, PAINTING, NAMELY, PENCILS, PENS, FOUNTAIN PENS; MATERIALS FOR ARTISTS, NAMELY, PENCILS, FOUNTAIN PENS, PENS, PENCILS, DRAWING PENS AND THEIR NIBS, PAINTING PENS, PAINTBRUSHES, PALETTES FOR PAINTERS; OFFICE MACHINES, NAMELY, TYPEWRITERS, ELECTRIC TYPEWRITERS, ADDRESSING MACHINE; FRANKING MACHINES, DUPLICATORS, NAMELY, DUPLICATING MACHINES, DOCUMENT COVERING DEVICES, NAMELY, DOCUMENT LAMINATORS FOR OFFICE USE, INKING RIBBONS FOR COMPUTER PRINTERS AND TYPEWRITERS, OFFICE REQUISITES, EXCEPT FURNITURE, NAMELY, OFFICE BASKETS, PADS, PAPER KNIVES, PAPER CLASPS, PAPER-CLIPS, TYPEWRITER RIBBONS, CACHETS, STAMP PADS, INKING PADS, WRITING AND DRAWING INKS, INDIA INK, CORRECTING FLUIDS FOR TYPE, ERASERS, PENCIL SHARPENERS, ELECTRIC PENCIL SHARPENERS, PRINTED EDUCATIONAL MATERIALS, EXCEPT FOR DEVICES, NAMELY, PRINTED GAMES; PRINTED TEACHING MATERIALS IN THE FIELD OF KITCHEN, FOOD AND HEALTHY LIVING; MODELING CLAYS AND PASTES, TERRESTRIAL GLOBES, BLACKBOARDS; DRAWING SETS, NAMELY, RULERS SETS,

SET SQUARES SETS, AND PROTRACTORS SETS AND COMBINATIONS SETS THEREOF; CHALKS, LETTERS AND NUMBERS, BRUSHES AND ROLLERS FOR WHITEWASHING AND PAINTING, FILTER PAPERS; PAPER FILTERS, NAMELY, FILTER PAPER AND PAPER FILTERS FOR COFFEE MAKERS; SPOOLS MADE OF PAPER OR CARDBOARD FOR INKING RIBBONS, WRAPPING PAPER (U.S. CLS. 2, 5, 22, 23, 29, 37, 38 AND 50).

CLASS 41—EDUCATION AND ENTERTAINMENT

FOR EDUCATIONAL SERVICES, NAMELY, PROVIDING CLASSES AND WORKSHOPS IN THE FIELD OF KITCHEN, FOOD AND HEALTHY LIVING; ANIMAL TRAINING, ARRANGING OF SYMPOSIUMS, CONFERENCES, CONGRESSES, AND SEMINARS, CONDUCTING OF SYMPOSIUMS, CONFERENCES, CONGRESSES, AND SEMINARS IN THE FIELD OF KITCHEN, FOOD AND HEALTHY LIVING; PROVIDING MUSEUM FACILITIES, ARRANGING OF BEAUTY CONTESTS, ORGANIZATION OF DANCE SHOWS, ORGANIZATION OF DANCE COMPETITIONS, LIBRARY SERVICES; PUBLICATION OF MAGAZINES, BOOKS, NEWSPAPERS AND TEXTS; ORGANIZATION OF SPORTS EVENTS, NAMELY, ORGANIZATION OF COMPETITIONS, ENTERTAINMENT SERVICES, PROVIDING CASINO FACILITIES, PRODUCTION OF FILMS, RADIO AND TELEVISION PROGRAMMES, NAMELY, PRODUCTION OF RADIO AND TELEVISION PROGRAMMES, EXCEPT PROGRAMMES FOR ADVERTISEMENT PURPOSES, PRODUCTION OF VIDEOTAPE FILMS AND CINE-FILMS, RECORDING STUDIO SERVICES, DUBBING, RENTAL OF CINE-FILMS AND VIDEOTAPE FILMS, RENTAL OF MOVIE PROJECTORS AND ACCESSORIES, RENTAL OF SOUND RECORDINGS, RENTAL OF VIDEO CASSETTES, RENTAL OF VIDEO CASSETTE RECORDERS, FACILITIES OF ART, NAMELY, PROVIDING CINEMA FACILITIES, THEATRE SERVICES, NAMELY, THEATRE PRODUCTIONS, MOVIE THEATRE PRESENTATIONS AND CINEMA THEATRE SERVICES, ORCHESTRA SERVICES, ORGANIZATION OF CONCERTS, ORGANIZATION OF SHOWS, BOOKING OF SEATS FOR SHOWS, MODELLING FOR ARTISTS, RENTAL OF SHOW SCENERY, NEWS REPORTERS SERVICES, PHOTOGRAPHIC REPORTING SERVICES, PHOTOGRAPHY, MICRO-FILM SERVICES, NAMELY, FILM PRODUCTION; TRANSLATION SERVICES, NAMELY, SIGN LANGUAGE INTERPRETATION (U.S. CLS. 100, 101 AND 107).

PRISCILLA MILTON, EXAMINING ATTORNEY

CLASS 6—METAL GOODS

FOR PREFABRICATED BUILDINGS OF METAL; PREFABRICATED TRANSPORTABLE BUILDINGS OF METAL; BRACKETS OF METAL FOR BUILDING; FITTINGS OF METAL FOR BUILDINGS; WALL CLADDINGS OF METAL FOR BUILDING; METAL CLADDING FOR BUILDING AND CONSTRUCTION; REINFORCING MATERIALS OF METAL FOR BUILDING PURPOSES; METAL WALL FRAMING; BOARDS OF METAL, NAMELY, CEILING BOARDS AND FLOOR BOARDS; BUILDING PANELS OF METAL, NAMELY, CEILING PANELS, DOOR PANELS, FLOOR PANELS; ALUMINUM, NAMELY, ALUMINUM ALLOYS; PARTITIONS OF METAL; METAL PARTITIONS WITH FRAMES OF METAL; METAL PARTITION WALLS WITH FRAMES OF METAL; KNOBS OF METAL; STAIRCASES OF METAL; FITTINGS AND TIES OF METAL FOR FURNITURE; GRILLES OF METAL, NAMELY, GRATINGS OF METAL; RAILINGS OF METAL FOR FENCES AND BALCONIES; BARS FOR METAL RAILINGS; DOOR FRAMES OF METAL; WAINSCOTING OF METAL; LATHS OF METAL; CEILINGS OF METAL, NAMELY, CEILING PANELS; FLOORS OF METAL, NAMELY, FLOOR PANELS OF METAL; GATES OF METAL; POSTS OF METAL; GIRDERS OF METAL; WALLS OF METAL, NAMELY, WALL PANELS OF METAL; METAL SKIRTING, NAMELY, METAL SKIRTING BOARDS FOR WALLS AND FLOORS; DOORS OF METAL; DOOR STOPS OF METAL; RUNNERS OF METAL FOR SLIDING DOORS; DOOR FITTINGS OF METAL; DOOR PANELS OF METAL; DOOR HANDLES OF METAL; METAL DOOR BOLTS; DOOR CLOSERS, NON-ELECTRIC; DOOR OPENERS, NON-ELECTRIC; WINDOWS OF METAL; WINDOW FRAMES OF METAL; WINDOW-STOPS OF METAL; SASH PULLEYS OF METAL; FITTINGS OF METAL FOR WINDOWS; WINDOW FASTENERS OF METAL; CASEMENT WINDOWS OF METAL; SHUTTERS OF METAL; CHAIN LINK AND WIRE FENCES OF METAL (U.S. CLS. 2, 12, 13, 14, 23, 25 AND 50).

CLASS 19—NON-METALLIC BUILDING MATERIALS

FOR NON METALLIC BUILDINGS, NAMELY, TRANSPORTABLE BUILDINGS OF TIMBER AND PRECAST CONCRETE; NON-METALLIC TRANSPORTABLE BUILDINGS OF TIMBER AND PRECAST CONCRETE; CLADDINGS, NOT OF METAL, FOR CONSTRUCTION AND BUILDING; WALL CLADDINGS, NOT OF METAL, FOR CONSTRUCTION AND BUILDING; REINFORCING MATERIALS, NOT OF METAL, FOR BUILDING PURPOSES; WINDOW AND DOOR FRAMES, NOT OF METAL; NON-METALLIC DOOR, FLOOR, AND WINDOW PANELS; BUILDING PANELS, NOT OF METAL; PARTITIONS WALLS WITH FRAMES, NOT OF METAL; STAIRS NOT OF METAL; DOOR CASING, NOT OF METAL; WAINSCOTING, NOT OF METAL; LATHS, NOT OF METAL; WOODEN PALISADING CEILING PANELS, NOT OF METAL; FLOORS, NOT OF METAL; GATES, NOT OF METAL; POSTS, NOT OF METAL; GIRDERS, NOT OF METAL; NON-METALLIC SIDEWALL PANELS; WOODEN SKIRTING BOARDS FOR WALLS AND FLOORS; DOORS, NOT OF METAL; DOOR FRAMES, NOT OF METAL; DOOR CASINGS, NOT OF METAL; NON-METALLIC DOOR PANELS; NON-METALLIC WINDOWS; WINDOW FRAMES, NOT OF METAL; NON-METAL SKYLIGHTS; WINDOW SHUTTERS, NOT OF METAL; FENCES, NOT OF METAL; WOOD PANELLING; FURRINGS OF WOOD, NAMELY, WOOD TRIM, WOOD POSTS, AND WOOD BEAMS; PARQUET FLOORING; GLAZED PARTITIONS, NAMELY, GLAZED PANELS FOR BUILDING OR CONSTRUCTION PURPOSES; PLATE GLASS WINDOWS, FOR BUILDING; BUILDING GLASS (U.S. CLS. 1, 12, 33 AND 50).

SN 79-088,481. MONOBLOC PARTITION, FRANCE, FILED 9-16-2010.



PRIORITY DATE OF 3-26-2010 IS CLAIMED.
OWNER OF INTERNATIONAL REGISTRATION 1054339 DATED 9-16-2010, EXPIRES 9-16-2020.

THE COLOR(S) GRAY, BLACK AND WHITE IS/ARE CLAIMED AS A FEATURE OF THE MARK.

THE MARK CONSISTS OF THE STYLIZED LETTER "M" IN GRAY, BLACK AND WHITE WITHIN A BLACK SQUARE. THE LETTER "M" IN THE BLACK SQUARE APPEARS ABOVE AND TO THE RIGHT OF THE STYLIZED WORD "MECANALU". THE LETTER "M" IN THE STYLIZED WORD "MECANALU" IS GRAY AND BLACK, THE OTHER LETTERS ARE BLACK.

CLASS 37—CONSTRUCTION AND REPAIR

FOR BUILDING AND CONSTRUCTION SERVICES; CONSTRUCTION SERVICES, NAMELY, INSTALLATION, REMOVAL AND REFITTING OF PARTITIONS; CONSTRUCTION SERVICES, NAMELY, INSTALLATION, REMOVAL AND REFITTING OF OFFICE PARTITIONS; INSTALLATION OF INTERIOR DECOR ITEMS; INSTALLATION SERVICES OF DOORS AND WINDOWS; BUILDING INSULATING, NAMELY, INSTALLATION OF INSULATING MATERIALS; MAINTENANCE AND REPAIR OF PARTITIONS; MAINTENANCE AND REPAIR OF OFFICE PARTITIONS AND INTERIOR DECOR ITEMS (U.S. CLS. 100, 103 AND 106).
JESSICA FATHY, EXAMINING ATTORNEY

SN 79-088,567. RETARUS GMBH, FED REP GERMANY,
FILED 9-1-2010.

RETARUS

THE MARK CONSISTS OF STANDARD CHARACTERS WITHOUT CLAIM TO ANY PARTICULAR FONT, STYLE, SIZE, OR COLOR.

OWNER OF INTERNATIONAL REGISTRATION 0798347
DATED 11-25-2002, EXPIRES 11-25-2012.

CLASS 9—ELECTRICAL AND SCIENTIFIC APPARATUS

FOR DATA PROCESSING EQUIPMENT AND COMPUTERS; APPARATUS FOR RECORDING, TRANSMISSION, PROCESSING AND REPRODUCTION OF DATA ON DATA MEDIA; FAX MACHINES; COMPUTER NETWORK HUBS AND COMMUNICATION HUBS; TELECOMMUNICATION AND DATA EXCHANGE SYSTEMS COMPRISED OF DATA CENTERS WITH SERVERS, MODEMS SOFTWARE, GATEWAYS, DATABASES; FAX SYSTEMS COMPRISED OF SERVERS, FAX BOARDS, PRINTED CIRCUIT BOARD ASSEMBLIES, VOIP DEVICES USED IN CONJUNCTION WITH ELECTRONIC MAIL (U.S. CLS. 21, 23, 26, 36 AND 38).

CLASS 35—ADVERTISING AND BUSINESS

FOR ADVERTISING; PROVISION OF ADVERTISING SPACE ON THE INTERNET; MANAGEMENT AND COMPILATION OF COMPUTERIZED DATABASES; COMPILATION AND SYSTEMIZATION OF DATABASES CONTAINING INFORMATION RELATING TO DISTRIBUTION LISTS FOR SENDING OR RECEIVING FAXES, ELECTRONIC MAIL AND VIA SHORT TEXT MESSAGING (SMS); ADMINISTRATIVE AND ORGANISATIONAL MANAGEMENT OF PROJECTS FOR DATA PROCESSING SYSTEMS (U.S. CLS. 100, 101 AND 102).

CLASS 37—CONSTRUCTION AND REPAIR

FOR INSTALLATION AND MAINTENANCE OF DATA PROCESSING INSTALLATIONS, COMPUTER NETWORKS AND TELECOMMUNICATION OR DATA EXCHANGE SYSTEMS (U.S. CLS. 100, 103 AND 106).

CLASS 38—COMMUNICATION

FOR PROVIDING ELECTRONIC TELECOMMUNICATIONS CONNECTIONS TO FACILITATE ELECTRONIC MAIL AND ACCESS COMPUTER DATABASES; PROVISION OF ACCESS TO THE INTERNET; PROVIDING REMOTE ACCESS TO THE INTERNET TO ALLOW FOR MANAGEMENT OF TELECOMMUNICATIONS AND DATA EXCHANGE SYSTEMS; ELECTRONIC MAIL AND MESSAGING SERVICES, NAMELY, RECEPTION, RECORDING, TRANSFER AND CONVERSION OF DATA AND MESSAGES, IN PARTICULAR FAXES, ELECTRONIC MAIL, SHORT WRITTEN MESSAGES (SMS), STRUCTURED DATA AND VOICE MESSAGES; PROVISION OF NETWORKS FOR EXCHANGE OF

DATA AND MESSAGES; ELECTRONIC MESSAGING SYSTEM, NAMELY, ELECTRONIC QUEUING SERVICES; FACSIMILE TRANSMISSION ON DEMAND SERVICES; TELECOMMUNICATIONS SERVICES, NAMELY, PROVIDING ADVANCED CALLING FEATURES, NAMELY, TELEPHONE CALLBACK; PROVIDING TELECOMMUNICATIONS CONNECTIONS TO A GLOBAL COMPUTER NETWORK, NAMELY, CONNECTING INTERNAL ELECTRONIC MAILING SYSTEMS TO GLOBAL MEDIA SERVICES; PROVIDING MOBILE USER ACCESS TO A GLOBAL COMPUTER NETWORK; PROVISION AND OPERATION OF SECURE CONNECTIONS; PROVIDING AND OPERATING ELECTRONIC TELECOMMUNICATIONS SERVICES AND APPLICATIONS LINKED TO THE INTERNET; TELECOMMUNICATIONS SERVICES, NAMELY, ELECTRONIC EXCHANGE AND INTERCHANGE OF DATA STORED IN DATABASES ACCESSIBLE VIA TELECOMMUNICATION NETWORKS; PROVISION OF COMMUNICATION MEANS OR STANDARDS SUCH AS TELEPHONY, FAXING, SHORT WRITTEN MESSAGES (SMS), EDI AND DATA TRANSMISSION; CONSULTING IN THE FIELD OF ELECTRONIC COMMUNICATIONS; PROVISION OF MANAGED ACCESS TO THE INTERNET, NAMELY, PROVIDING INTERNET PROXIMITY SERVICES VIA WEB PROXY; FACSIMILE TRANSMISSION SERVICES; PROVIDING ONLINE FACSIMILE TRANSMISSION SERVICES; MESSAGE SENDING AND RECEIVING SERVICES, NAMELY, SENDING, PROVISION AND RECEPTION OF TELEPHONE AND ELECTRONIC CALLBACKS, ELECTRONIC MAIL, FAXES, AND SMS (U.S. CLS. 100, 101 AND 104).

CLASS 41—EDUCATION AND ENTERTAINMENT

FOR TRAINING SERVICES IN THE FIELD OF COMPUTING, COMPUTER DATA PROCESSING AND ELECTRONIC COMMUNICATION (U.S. CLS. 100, 101 AND 107).

CLASS 42—SCIENTIFIC AND COMPUTER SERVICES

FOR PROVISION OF MEMORY SPACE FOR INTERMEDIATE SAVING OF ELECTRONIC DATA AND MESSAGES; DEVELOPMENT, PLANNING AND TECHNICAL PROJECT MANAGEMENT, NAMELY, COMPUTER SOFTWARE AND HARDWARE CONSULTING AND SOLUTION DESIGN FOR DATA PROCESSING SYSTEMS AND IT INFRASTRUCTURE SOLUTIONS; OPERATION OF DATA PROCESSING INSTALLATIONS AND COMPUTER NETWORKS; DEVELOPMENT, PLANNING, INDIVIDUAL ADAPTATION, INSTALLATION AND IMPLEMENTATION OF SOFTWARE; TECHNICAL SUPPORT SERVICES, NAMELY, TROUBLESHOOTING IN THE NATURE OF DIAGNOSING COMPUTER HARDWARE, COMPUTER SOFTWARE AND COMPUTER NETWORK PROBLEMS; MAINTENANCE OF COMPUTER SOFTWARE RELATING TO COMPUTER SECURITY AND PREVENTION OF COMPUTER RISKS; ELECTRONIC DOCUMENT AND E-MAIL AUTHENTICATION SERVICES; DATA ENCRYPTION AND DECRYPTION SERVICES; PROVIDING ONLINE NON-DOWNLOADABLE SOFTWARE FOR PROTECTION OF ELECTRONIC MESSAGES AGAINST NON-AUTHORISED ACCESS, VIRUSES AND DATA LOSS; COMPUTER SERVICES, NAMELY, ON-LINE SCANNING, DETECTING, QUARANTINING AND ELIMINATING SPAM, VIRUSES, WORMS, TROJANS, SPYWARE, ADWARE, MALWARE AND UNAUTHORIZED DATA AND PROGRAMS ON COMPUTERS AND ELECTRONIC DEVICES; APPLICATION SERVICE PROVIDER (ASP) FEATURING SOFTWARE FOR USE IN PROVIDING TECHNICAL SUPPORT SERVICES IN THE NATURE OF DIAGNOSING COMPUTER SOFTWARE AND HARDWARE PROBLEMS; CONSULTING IN THE FIELD OF ELECTRONIC DATA PROCESSING; SECURITY CONTROL FOR DATA PROCESSING INSTALLATIONS, TELECOMMUNICATION SYSTEMS AND DATA EXCHANGE SYSTEMS; DATA ENCRYPTION SERVICES, NAMELY, PROTECTION OF DATA PROCESSING INSTALLATIONS, TELECOMMUNICATION SYSTEMS AND DATA EXCHANGE SYSTEMS BY MEANS OF ENCODING OF DATA, ELECTRONIC MESSAGES AND ACCESS CODES BY CRYPTOGRAPHIC AND TECHNICAL MEANS AND ALSO BY INSTALLA-

TION OF INTERLOCKING ACCESS TO DATA, TO COMPUTER NETWORKS AND COMPUTERS BY TECHNICAL MEANS; COMPUTER PROJECT MANAGEMENT SERVICES; COMPUTER AND IT INFRASTRUCTURE SECURITY CONSULTATION SERVICES, NAMELY, PROVISION AND DEVELOPMENT OF SOLUTIONS FOR REMOTE ACCESS TO ELECTRONIC MESSAGES, APPLICATIONS AND DATABASES VIA NETWORKED COMPUTERS AND HANDHELD COMPUTERS; PROVIDING A SECURED-ACCESS WEBSITE THAT GIVES REGISTERED INTERNET NETWORKED INSTITUTIONS THE ABILITY TO UPLOAD, VIEW, COPY, PRINT, DOWNLOAD AND SHARE DOCUMENTS AND IMAGES FOR THE PURPOSES OF INTERCHANGE AND STORAGE OF DATA, SENDING NEWSLETTERS, ELECTRONIC INVOICES FOR E-MAIL RETENTION; TECHNICAL CONSULTING SERVICES, NAMELY, DEVELOPMENT AND PROVISION OF ENTERPRISE RESOURCE MANAGEMENT AND CUSTOMER RELATIONSHIP MANAGEMENT SOLUTIONS ASSOCIATED WITH FAX SYSTEMS FOR DISPATCH, RECEPTION AND CONVERSION OF FAXES FOR DIFFERENT APPLICATIONS AND FOR CONNECTION OF INCOMPATIBLE SYSTEMS FOR FAX MACHINES TO COMPUTING SYSTEMS, ELECTRONIC AND TELEPHONE MESSAGING COMPATIBLE WITH FAXES; DEVELOPMENT OF NEW TECHNOLOGY FOR OTHERS OF FAX SYSTEMS FOR OFFICE USE; DEVELOPMENT OF NEW TECHNOLOGY FOR OTHERS OF FAX SYSTEMS FOR INTERNET AND INTRANET USE; GATEWAY SERVICES FOR CROSS-MEDIA APPLICATIONS, FOR EXAMPLE "FAX2MAIL" OR "MAIL2FAX"; DEVELOPMENT OF NEW TECHNOLOGY FOR OTHERS OF COMMUNICATIONS MEANS OR STANDARDS SUCH AS TELEPHONY, FAX, SHORT WRITTEN MESSAGES (SMS), EDI AND DATA TRANSMISSION; DEVELOPMENT AND PROVISION OF COMPUTER SOFTWARE AND HARDWARE FOR CONVERSION OF DATA AND INFORMATION TRANSMITTED ELECTRONICALLY BY DIFFERENT MEANS OF COMMUNICATION THROUGH PROVISION OF GATEWAYS BETWEEN DIFFERENT MEDIAS AND STANDARDS; TECHNICAL SUPPORT SERVICES, NAMELY, REMOTE ADMINISTRATION OF DATA PROCESSING COMPUTER PROGRAMS AND THE RESPECTIVE HARDWARE; COMPUTER VIRUS PROTECTION SERVICES, NAMELY, VIRUS DETECTION, PROVISION AND OPERATION OF SPAM PROTECTION FOR ELECTRONIC MAIL SYSTEMS; DESIGN AND DEVELOPMENT OF COMPUTER SERVERS, APPLICATIONS AND DATABASES LINKED TO THE INTERNET (U.S. CLS. 100 AND 101).

PAM WILLIS, EXAMINING ATTORNEY

SN 79-089,532. AGUSTAWESTLAND-POLITECNICO ADVANCED ROTORCRAFT CENTER SOCIETA' CONSORTILE A RESPONSABILITA' LIMITATA, ITALY, FILED 9-10-2010.



PRIORITY DATE OF 9-1-2010 IS CLAIMED.
OWNER OF INTERNATIONAL REGISTRATION 1057072 DATED 9-10-2010, EXPIRES 9-10-2020.

NO CLAIM IS MADE TO THE EXCLUSIVE RIGHT TO USE "COMPANY ADVANCED ROTORCRAFT CENTER" AND "POLITECNICO DI MILANO", APART FROM THE MARK AS SHOWN.

THE COLOR(S) BLACK, RED, WHITE, GREEN AND BLUE IS/ARE CLAIMED AS A FEATURE OF THE MARK.

THE MARK CONSISTS OF A DESIGN OF 3 SUPERIMPOSED HELICOPTERS IN RED, WHITE AND GREEN SURROUNDED BY A BLUE ELLIPSE. THIS ELLIPSE IS INTERRUPTED IN THE TOP LEFT BY THE WORDING "AGUSTA WESTLAND" IN BLUE EXCEPT THE FIRST "A" AND THE "W" WHICH ARE IN RED. BELOW THIS WORDING IS THE WORDING "A FINMECCANICA COM-

PANY" IN BLACK. TO THE TOP LEFT OF "AGUSTA" IS A HEMISPHERIC DESIGN MADE UP BY SEVEN SLICES IN RED AND BLACK. THE SAME ELLIPSE IS INTERRUPTED TO THE BOTTOM RIGHT BY THE WORDING "POLITECNICO DI MILANO" IN BLACK. TO THE LEFT OF THIS WORDING IS A BLACK CIRCULAR DESIGN CONSISTING OF A DRAWING OF GREEK PHILOSOPHERS AND STUDENTS AND THE WORDING "POLITECNICO" AT THE TOP AND "MILANO" AT THE BOTTOM. ABOVE THE HELICOPTER DESIGN BUT INSIDE THE ELLIPSE IS THE WORDING "ADVANCED ROTORCRAFT CENTER-AWPAC" IN BLUE.

THE ENGLISH TRANSLATION OF "POLITECNICO DI MILANO" IN THE MARK IS "POLYTECHNIC UNIVERSITY OF MILAN".

CLASS 9—ELECTRICAL AND SCIENTIFIC APPARATUS

FOR ELECTRICAL, ELECTRONIC, MEASURING, SIGNALING, SENSING AND CHECKING APPARATUS AND INSTRUMENTS FOR USE IN AIRCRAFT, ROTARY WING AIRCRAFT, HELICOPTERS, TILT ROTOR AIRCRAFT, NAMELY, FLIGHT MANAGEMENT SYSTEMS, FLIGHT SIMULATORS, AUTOMATIC FLIGHT CONTROL SYSTEMS, SENSORS AND INSTRUMENTS FOR NAVIGATION FOR HELICOPTERS AND AIRCRAFT; ELECTRONIC PUBLICATIONS, NAMELY, TRAINING AND TECHNICAL MANUALS FEATURING OPERATION OF HELICOPTERS AND AIRCRAFT, TRAINING AND TECHNICAL MANUALS FOR FLIGHT SIMULATION OF HELICOPTERS AND AIRCRAFT RECORDED ON COMPUTER MEDIA; COMPUTER SOFTWARE FOR USE IN THE OPERATION AND FLIGHT SIMULATION AND TESTING OF HELICOPTERS AND AIRCRAFT; COMMUNICATIONS APPARATUS AND INSTRUMENTS, NAMELY, ANTENNAS, TRANSMITTERS AND RECEIVERS; TESTING APPARATUS AND INSTRUMENTS, NAMELY, ELECTRONIC TESTERS OF PARTS AND COMPONENTS OF HELICOPTERS AND AIRCRAFT (U.S. CLS. 21, 23, 26, 36 AND 38).

CLASS 16—PAPER GOODS AND PRINTED MATTER

FOR PRINTED MATTER, NAMELY, TEACHING, TECHNICAL AND TRAINING MANUALS IN THE FIELD OF HELICOPTERS AND AIRCRAFT (U.S. CLS. 2, 5, 22, 23, 29, 37, 38 AND 50).

CLASS 41—EDUCATION AND ENTERTAINMENT

FOR TEACHING AND TRAINING SERVICES IN RESPECT OF THE USE, REPAIR, MAINTENANCE, INSTALLATION, AND CONSTRUCTION OF AIRCRAFT, ROTARY WING AIRCRAFT, HELICOPTERS AND TILT ROTOR AIRCRAFT (U.S. CLS. 100, 101 AND 107).

CLASS 42—SCIENTIFIC AND COMPUTER SERVICES

FOR DESIGN FOR OTHERS OF MISSION, AVIONICS, COMMUNICATION AND NAVIGATION SYSTEMS FOR HELICOPTERS AND AIRCRAFT; DESIGN FOR OTHERS OF COMPONENTS OF HELICOPTERS AND AIRCRAFT, NAMELY, SENSORS, SIGHTING AND TARGETING SYSTEMS, DYNAMIC COMPONENTS AND SYSTEMS, AVIONICS SUPPORT SYSTEMS, INTEGRATED LOGISTIC SUPPORT SYSTEMS AND ENGINES; TESTING OF AIRCRAFT, ROTARY WING AIRCRAFT, HELICOPTERS, TILT ROTOR AIRCRAFT OF OTHERS FOR THE PURPOSES OF FLIGHT (U.S. CLS. 100 AND 101).

WENDY JUN, EXAMINING ATTORNEY

SN 79-090,147. SELO MEDICAL GMBH, A-5585 UNTERBERG, AUSTRIA, FILED 9-14-2010.

SELO

THE MARK CONSISTS OF STANDARD CHARACTERS WITHOUT CLAIM TO ANY PARTICULAR FONT, STYLE, SIZE, OR COLOR.

PRIORITY DATE OF 6-4-2010 IS CLAIMED.

OWNER OF INTERNATIONAL REGISTRATION 1058761 DATED 9-14-2010, EXPIRES 9-14-2020.

CLASS 3—COSMETICS AND CLEANING PREPARATIONS

FOR PERFUMERY, COSMETICS (U.S. CLS. 1, 4, 6, 50, 51 AND 52).

CLASS 5—PHARMACEUTICALS

FOR PHARMACEUTICAL AND VETERINARY PREPARATIONS USED TO TREAT HERPES SIMPLEX INFECTIONS, GUM, LIP, TONGUE AND MOUTH DISEASE AND INFLAMMATIONS, GYNECOLOGICAL DISEASES AND DISORDERS, UTERINE INFLAMMATIONS, TOPICAL INFLAMMATIONS, INSECT BITES, SUNBURN AND DRY SKIN; DIETETIC FOODS ADAPTED FOR MEDICAL PURPOSES USED TO TREAT HERPES SIMPLEX INFECTIONS, GUM, LIP, TONGUE AND MOUTH DISEASE AND INFLAMMATIONS, GYNECOLOGICAL DISEASES AND DISORDERS, UTERINE INFLAMMATIONS, TOPICAL INFLAMMATIONS, INSECT BITES, SUNBURN AND DRY SKIN, FOOD FOR BABIES; NUTRITIONAL ADDITIVES FOR MEDICAL PURPOSES USED IN FOODS AND DIETARY SUPPLEMENTS FOR HUMAN CONSUMPTION USED TO TREAT HERPES SIMPLEX INFECTIONS, GUM, LIP, TONGUE AND MOUTH DISEASE AND INFLAMMATIONS, GYNECOLOGICAL DISEASES AND DISORDERS, UTERINE INFLAMMATIONS, TOPICAL INFLAMMATIONS, INSECT BITES, SUNBURN AND DRY SKIN; ALL GOODS MENTIONED BEFORE DO NOT INCLUDE PHARMACEUTICAL PREPARATIONS FOR THE TREATMENT OF RESPIRATORY DISEASES (U.S. CLS. 6, 18, 44, 46, 51 AND 52).

SCOTT BIBB, EXAMINING ATTORNEY

SN 79-090,328. SHANDA COMPUTER (SHANGHAI) CO., LTD., CHINA, FILED 11-12-2010.

Bambook

OWNER OF INTERNATIONAL REGISTRATION 1059394 DATED 11-12-2010, EXPIRES 11-12-2020.

THE MARK CONSISTS OF THE WORD "BAMBOOK" WITH A BAMBOO BRANCH RISING OUT OF THE SECOND LETTER "B".

CLASS 9—ELECTRICAL AND SCIENTIFIC APPARATUS

FOR DIGITAL MEDIA, NAMELY, CDS, DVDS; DOWNLOADABLE AUDIO FILES IN THE FIELD OF VIDEO GAMES, CULTURE, ART AND HISTORY; COMPUTER GAME PROGRAMS; COMPUTER GAME SOFTWARE DOWNLOADABLE FROM A GLOBAL COMPUTER NETWORK; DOWNLOADABLE COMPUTER PROGRAMS AND COMPUTER SOFTWARE FOR CONNECTIVITY BETWEEN COMPUTER GAME MACHINES; DOWNLOADABLE COMPUTER SOFTWARE FOR WORD PROCESSING; COMPUTERS; INTERACTIVE REMOTE CONTROL FOR VIDEO GAMES; APPARATUS FOR GAMES ADAPTED FOR USE WITH AN EXTERNAL DISPLAY SCREEN OR MONITOR; AMUSEMENT APPARATUS ADAPTED FOR USE WITH AN EXTERNAL DISPLAY OR MONITOR; VIDEO DISKS AND VIDEO TAPES WITH RECORDED ANIMATED CARTOONS; SOUND RECORDING DISCS (U.S. CLS. 21, 23, 26, 36 AND 38).

CLASS 41—EDUCATION AND ENTERTAINMENT

FOR ORGANIZATION OF EDUCATION OR ENTERTAINMENT COMPETITIONS IN THE FIELD OF GAMES FOR ADULTS AND CHILDREN TO BE PLAYED ELECTRONICALLY, NAMELY, ORGANIZING COMPETITIONS IN THE FIELD OF CULTURE, ART, MUSIC, SPORTS, TECHNOLOGY, MEDICINE AND MATH; EDUCATION INFORMATION; EDUCATIONAL SERVICES, NAMELY, CONDUCTING WORKSHOPS IN THE FIELD OF GAMES FOR ADULTS AND CHILDREN TO BE PLAYED ELECTRONICALLY, NAMELY, ELECTRONIC GAMES IN THE FIELD OF CULTURE, ART, MUSIC, SPORTS, TECHNOLOGY, MEDICINE AND MATH; PRODUCTION OF TELEVISION SHOWS; ENTERTAINMENT SERVICES, NAMELY, PROVIDING ON-LINE COMPUTER GAMES PROVIDED ON-LINE FROM COMPUTER NETWORK (U.S. CLS. 100, 101 AND 107).

KELLY TRUSILO, EXAMINING ATTORNEY

SN 79-090,531. KONGSBERG AUTOMOTIVE HOLDING ASA, NORWAY, FILED 10-8-2010.

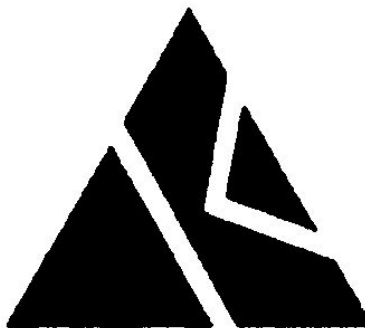

PRIORITY DATE OF 9-9-2010 IS CLAIMED.

OWNER OF INTERNATIONAL REGISTRATION 1059924 DATED 10-8-2010, EXPIRES 10-8-2020.

THE MARK CONSISTS OF A DESIGN HAVING AN OVERALL TRIANGLE SHAPE AND INCORPORATING A SMALLER TRIANGLE ON THE LOWER LEFT CORNER AND ANOTHER TRIANGLE ALONG THE RIGHT SIDE OF THE TRIANGLE.

CLASS 12—VEHICLES

FOR VEHICLES FOR LOCOMOTION BY LAND, AIR OR WATER, NAMELY, AUTOMOBILES, MOTORCYCLES, ALL-TERRAIN VEHICLES, TRUCKS, AIRCRAFT, HELICOPTERS, SHIPS, BOATS, RAIL LOCOMOTIVES, AND AGRICULTURAL AND CONSTRUCTION VEHICLES, NAMELY, TRACTORS AND TRUCKS (U.S. CLS. 19, 21, 23, 31, 35 AND 44).

CLASS 42—SCIENTIFIC AND COMPUTER SERVICES

FOR SCIENTIFIC AND TECHNOLOGICAL SERVICES, NAMELY, RESEARCH AND DESIGN RELATING TO VEHICLES FOR LOCOMOTION BY LAND, AIR OR WATER, NAMELY, AUTOMOBILES, MOTORCYCLES, ALL-TERRAIN VEHICLES, TRUCKS, AIRCRAFT, HELICOPTERS, SHIPS, BOATS, RAIL LOCOMOTIVES, AND AGRICULTURAL AND CONSTRUCTION VEHICLES, NAMELY, TRACTORS AND TRUCKS, AND ALSO RELATING TO STRUCTURAL PARTS FOR ALL OF THE FOREGOING VEHICLES (U.S. CLS. 100 AND 101).

DOMINIC FATHY, EXAMINING ATTORNEY

CLASS 38—COMMUNICATION

FOR ELECTRONIC EXCHANGE OF DATA STORED IN DATABASES ACCESSIBLE VIA TELECOMMUNICATION NETWORKS; ELECTRONIC DOCUMENT AND INFORMATION EXCHANGE SERVICES VIA TELECOMMUNICATION NETWORKS; ELECTRONIC BULLETIN BOARD SERVICES; TELECOMMUNICATIONS VIA COMPUTER TERMINALS, COMPUTER COMMUNICATION, RADIO, TELEGRAM, TELEPHONE; TELECOMMUNICATION SERVICES FOR THE CREATION AND MAINTENANCE OF FILES RELATING TO BRAND PROTECTION, TRACEABILITY PRODUCTS AND DOCUMENTS SECURITY; TRANSMISSION SERVICES, NAMELY, ELECTRONIC AND COMPUTER TRANSMISSION OF DATA, COMPUTER-ASSISTED SENDING OF MESSAGES, DATA, DOCUMENTS AND IMAGES; TRANSMISSION OF COMPUTER DATA VIA DATA EXCHANGE, TRANSMITTING OF INFORMATION CONTAINED IN DATA BANKS; PROVIDING USER ACCESS TO A GLOBAL COMPUTER NETWORK, NAMELY, INTERNET SERVICE PROVIDERS; PROVIDING USER ACCESS TO DATABASES AND THE INTERNET VIA TELECOMMUNICATIONS; PROVIDING USER ACCESS TO ELECTRONIC COMMUNICATION NETWORKS AND ELECTRONIC DATABASES; PROVIDING MULTIPLE USERS WITH ACCESS TO COMPUTER NETWORKS, WIRELESS NETWORKS AND THE INTERNET; PROVIDING ACCESS TO ON-LINE COMPUTER DATABASES, TO DATABASES THAT CAN BE USED ON-LINE; INFORMATION, ASSISTANCE AND ADVICE CONCERNING ALL THE AFOREMENTIONED SERVICES, INCLUDING SERVICES PROVIDED ON-LINE AND ON THE INTERNET AND ON EXTRANETS; ACCESS AND RENTAL OF ACCESS TIME TO THE INTERNET AND TO COMPUTER NETWORKS AND DATABASES (U.S. CLS. 100, 101 AND 104).

FRANK LATTUCA, EXAMINING ATTORNEY

SN 79-090,730. ADVANCED TRACK AND TRACE (ATT), FRANCE, FILED 8-13-2010.

SN 79-090,775. LENSWISTA AG, FED REP GERMANY, FILED 11-8-2010.

Razad

THE MARK CONSISTS OF STANDARD CHARACTERS WITHOUT CLAIM TO ANY PARTICULAR FONT, STYLE, SIZE, OR COLOR.

PRIORITY DATE OF 2-18-2010 IS CLAIMED.

OWNER OF INTERNATIONAL REGISTRATION 1060436 DATED 8-13-2010, EXPIRES 8-13-2020.

CLASS 35—ADVERTISING AND BUSINESS

FOR PHYSICAL AND ELECTRONIC REPRODUCTION OF DOCUMENTS; COMPILATION OF INFORMATION INTO COMPUTER DATABASES, SYSTEMIZATION OF INFORMATION INTO COMPUTER DATABASES, MANAGEMENT OF COMPUTERIZED FILES AND DATABASES, DATA SEARCH IN COMPUTER FILES, THE AFOREMENTIONED SERVICES BEING PROVIDED IN THE FIELD OF THE TRACEABILITY, AUTHENTICATION AND SECURING OF GOODS; BUSINESS MANAGEMENT ADVICE; COMMERCIAL AND INDUSTRIAL BUSINESS MANAGEMENT ASSISTANCE; COMMERCIAL MARKETING ADVICE; ADVICE IN THE FIELD OF MANAGING CUSTOMER RELATIONS FOR COMPANIES; ADVICE ON ADVERTISING AND COMMERCIAL COMMUNICATION; THE AFOREMENTIONED SERVICES BEING PROVIDED IN THE FIELD OF THE TRACEABILITY, AUTHENTICATION AND SECURING OF GOODS (U.S. CLS. 100, 101 AND 102).

LensWista

THE MARK CONSISTS OF STANDARD CHARACTERS WITHOUT CLAIM TO ANY PARTICULAR FONT, STYLE, SIZE, OR COLOR.

OWNER OF INTERNATIONAL REGISTRATION 1060577 DATED 11-8-2010, EXPIRES 11-8-2020.

THE WORDING "LENSWISTA" HAS NO MEANING IN A FOREIGN LANGUAGE.

CLASS 5—PHARMACEUTICALS

FOR MEDICINAL PREPARATIONS FOR THE TREATMENT OF EYE DISEASES AND AMETROPIA; CONTACT LENS DISINFECTANTS AND WETTING PREPARATIONS; CONTACT LENS SOLUTIONS; EYE WASHES; CHEMICAL PREPARATIONS FOR PHARMACEUTICAL OR MEDICAL PURPOSES, NAMELY, FOR THE TREATMENT OF EYE DISEASES, MYOPIA, ANTIMIOPIA, ASRIGMATISM AND PRESBYOPIA; DIAGNOSTIC PREPARATIONS FOR MEDICAL PURPOSES; GERMICIDES; PHARMACEUTICAL PREPARATIONS FOR THE TREATMENT OF EYE DISEASES AND AMETROPIA; ANTICRYPTOGAMIC PREPARATIONS; CONTACT LENS CLEANING PREPARATIONS; SURGING IMPLANTS COMPRISING LIVING TISSUES (U.S. CLS. 6, 18, 44, 46, 51 AND 52).

CLASS 9—ELECTRICAL AND SCIENTIFIC APPARATUS

FOR CONTACT LENSES, IN PARTICULAR CONTACT LENSES OF RUBBER WITH BIOCOMPATIBLE SURFACE LAYERS; CONTAINERS FOR CONTACT LENSES; EYEGLOSS LENSES; OPTICAL GOODS, NAMELY, OPTICAL GLASSES AND EYEGLOSS FRAMES; OPTICAL LENSES; PERMANENT LENSES, NAMELY, OPTICAL LENSES FOR SPHERICAL, TORIC AND MULTIFOCAL LENSES AND MAGNIFYING AND BANDAGE PURPOSES; OPHTHALMIC LENSES; INDICATOR LENSES, NAMELY, ANTI-REFLECTIVE LENSES; CASES FOR CONTACT LENSES (U.S. CLS. 21, 23, 26, 36 AND 38).

CLASS 10—MEDICAL APPARATUS

FOR SURGICAL IMPLANTS COMPRISING ARTIFICIAL MATERIAL; SURGICAL CUTLERY; MEDICAL NEEDLES; SUTURE MATERIALS; SURGICAL CATGUT; INTRAOCULAR LENSES FOR SURGICAL IMPLANTATION; NEEDLES FOR MEDICAL PURPOSES; SURGICAL APPARATUS FOR USE IN GENERAL SURGERY FOR MEDICAL OR VETERINARY PURPOSES (U.S. CLS. 26, 39 AND 44).

DAWN HAN, EXAMINING ATTORNEY

SN 79-090,864. BRIDGEDALE OUTDOOR LIMITED, IRELAND, FILED 10-25-2010.

MERINOFUSION

THE MARK CONSISTS OF STANDARD CHARACTERS WITHOUT CLAIM TO ANY PARTICULAR FONT, STYLE, SIZE, OR COLOR.

OWNER OF INTERNATIONAL REGISTRATION 1060717 DATED 10-25-2010, EXPIRES 10-25-2020.

CLASS 23—YARNS AND THREADS

FOR YARNS MADE IN WHOLE OR SIGNIFICANT PART OF MERINO WOOL; THREADS MADE IN WHOLE OR SIGNIFICANT PART OF MERINO WOOL; TEXTILE YARNS MADE IN WHOLE OR SIGNIFICANT PART OF MERINO WOOL; POLYPROPYLENE YARNS MADE IN WHOLE OR SIGNIFICANT PART OF MERINO WOOL (U.S. CL. 43).

CLASS 24—FABRICS

FOR TEXTILE AND TEXTILE GOODS MADE IN WHOLE OR SIGNIFICANT PART OF MERINO WOOL, NAMELY, TEXTILES FOR MAKING ARTICLES OF CLOTHING (U.S. CLS. 42 AND 50).

CLASS 25—CLOTHING

FOR CLOTHING, NAMELY, SOCKS, GLOVES, HATS, GAITERS AND BASE LAYERS ALL MADE IN WHOLE OR SIGNIFICANT PART OF MERINO WOOL (U.S. CLS. 22 AND 39).

DEIRDRE ROBERTSON, EXAMINING ATTORNEY

SN 79-091,221. DISPLAY S.R.L., ITALY, FILED 8-2-2010.



PRIORITY DATE OF 6-3-2010 IS CLAIMED.

OWNER OF INTERNATIONAL REGISTRATION 1061619 DATED 8-2-2010, EXPIRES 8-2-2020.

OWNER OF U.S. REG. NO. 3,627,227.

NO CLAIM IS MADE TO THE EXCLUSIVE RIGHT TO USE "SPORTS", APART FROM THE MARK AS SHOWN.

THE COLOR(S) BLUE, RED AND WHITE IS/ARE CLAIMED AS A FEATURE OF THE MARK.

THE MARK CONSISTS OF THE WORDING "CLUB DES SPORTS" IN WHITE ON A BLUE BACKGROUND. THE TERM "DES" APPEARS ROTATED VERTICALLY WITH EACH LETTER ON AN INDIVIDUAL RED RECTANGLE.

CLASS 9—ELECTRICAL AND SCIENTIFIC APPARATUS

FOR SPECTACLES, SUN GLASSES, FRAMES AND CASES FOR SPECTACLES AND SUN GLASSES (U.S. CLS. 21, 23, 26, 36 AND 38).

CLASS 14—JEWELRY

FOR PRECIOUS METALS AND THEIR ALLOYS AND GOODS IN PRECIOUS METALS OR COATED THEREWITH, NOT INCLUDED IN OTHER CLASSES, NAMELY, RINGS, NECKLACES, BRACELETS, BROOCHES, EARRINGS, TIE CLIPS, CUFF-LINKS, DIAMONDS, JEWELRY CASES MADE OF PRECIOUS METAL, WATCHES, CLOCKS, CHRONOMETERS, WATCH CASES, COSTUME JEWELRY; JEWELRY, PRECIOUS STONES; HOROLOGICAL AND CHRONOMETRIC INSTRUMENTS (U.S. CLS. 2, 27, 28 AND 50).

CLASS 28—TOYS AND SPORTING GOODS

FOR ARTICLES FOR GYMNASTIC AND SPORTS, NAMELY, BALLOONS, BASEBALLS, TABLE TENNIS TABLES, TENNIS TABLE RACKETS, TENNIS TABLE POST SETS, TENNIS TABLE PADDLES, TENNIS TABLE NETS, TENNIS TABLE BALLS, HOCKEY STICKS, BOWLING BALLS, SKIS, SOCCER BALLS, HAND BALLS, SOCCER BALL GOAL NETS, BASKET BALLS, GOLF BAGS, GOLF ACCESSORY POUCHES, GOLF CLUBS, CLIMBING SKINS FOR USE WITH TOURING SKIS, COVERS FOR SKI BINDINGS, PORTABLE SKI CARRIERS, SKI BAGS, SKI BINDINGS AND PARTS THEREOF, SKI BRAKES, SKI CASES, SKI COVERS, SKI EDGES, SKI POLES, SKI ROPES, SKI SCRAPERS, SKI STICKS, SKATEBOARDS, ICE SKATES, PLAYGROUND BALLS, BASEBALL GLOVES, SWIMMING AIDS, NAMELY, POOL RINGS AND ARM FLOATS FOR RECREATIONAL USE, SURF BOARDS, SWIM BOARDS FOR RECREATIONAL USE AND SWIM FINS (U.S. CLS. 22, 23, 38 AND 50).

CLASS 35—ADVERTISING AND BUSINESS

FOR RETAIL STORE SERVICES FOR THE BENEFIT OF OTHERS FEATURING SOAPS, PERFUMERY, ESSENTIAL OILS, COSMETICS, LEATHER AND IMITATIONS OF LEATHER, AND GOODS MADE OF LEATHER AND IMITATIONS OF LEATHER, ANIMAL SKINS, HIDES, TRUNKS AND TRAVELLING BAGS, UMBRELLAS, PARASOLS AND WALKING STICKS, WHIPS, HARNESS AND SADDLERY, CLOTHING, FOOTWEAR, HEADGEAR, SPECTACLES, SUN GLASSES, FRAMES AND CASES FOR SPECTACLES AND SUN GLASSES, PRECIOUS METALS AND THEIR ALLOYS AND GOODS IN PRECIOUS METALS OR COATED THEREWITH, NOT INCLUDED IN OTHER CLASSES, JEWELRY, PRECIOUS STONES, HOROLOGICAL AND CHRONOMETRIC INSTRUMENTS, ARTICLES FOR GYMNASTIC AND SPORTS, NOT INCLUDED IN OTHER CLASSES, NAMELY, SPORTING EQUIPMENT AND SPORT BAGS AND KNAPSACKS, ENABLING CUSTOMERS TO CONVENIENTLY VIEW AND PURCHASE THOSE GOODS; BUSINESS MANAGEMENT FOR FRANCHISING (U.S. CLS. 100, 101 AND 102).

JESSICA A. POWERS, EXAMINING ATTORNEY

SN 79-091,630. SORRENTINO BONAVENTURA, ITALY,
FILED 9-16-2010.



PRIORITY DATE OF 7-22-2010 IS CLAIMED.
OWNER OF INTERNATIONAL REGISTRATION 1062526
DATED 9-16-2010, EXPIRES 9-16-2020.
THE TRADEMARK CONSISTS OF THE WORDING "AG"
IN FANCY CHARACTER.

CLASS 9—ELECTRICAL AND SCIENTIFIC APPARATUS

FOR OPTICAL PRODUCTS, NAMELY, SPECTACLES AND SUNGLASSES, EYEGGLASS FRAMES, LENSES, AND CASES FOR SPECTACLES AND SUNGLASSES; SPORT GOGGLES FOR USE IN SKIING, SWIMMING, MOTORCYCLING; EYEGGLASS CHAINS (U.S. CLS. 21, 23, 26, 36 AND 38).

CLASS 18—LEATHER GOODS

FOR LEATHER AND IMITATIONS OF LEATHER SOLD IN BULK; LEATHER GOODS, NAMELY, HANDBAGS, PURSES, WALLETS, BRIEFCASES, TOILETRY CASES SOLD EMPTY, COSMETIC CASES SOLD EMPTY; ANIMAL SKINS, ANIMAL HIDES; HANDBAGS, LUGGAGE, SHOULDER BAGS, BEACH BAGS, CLUTCH BAGS, ALL PURPOSE SPORT BAGS, ATTACH CASES, SCHOOL BAGS, TOTE BAGS, CREDIT CARD CASES OF LEATHER, DOCUMENT CASES, COSMETIC CASES SOLD EMPTY, KEY CASES, KNAPSACKS, RUCKSACKS, BRIEFCASES, LUGGAGE TRUNKS, SUITCASES, UMBRELLAS, PARASOLS, WALKING STICKS (U.S. CLS. 1, 2, 3, 22 AND 41).

MATTHEW EINSTEIN, EXAMINING ATTORNEY

SN 79-091,757. INOUE HIROKI, JAPAN, AND ISHIZUKA HIROYUKI, JAPAN, FILED 7-30-2010.

THE MARK CONSISTS OF STANDARD CHARACTERS WITHOUT CLAIM TO ANY PARTICULAR FONT, STYLE, SIZE, OR COLOR.

PRIORITY DATE OF 6-21-2010 IS CLAIMED.
OWNER OF INTERNATIONAL REGISTRATION 1062856
DATED 7-30-2010, EXPIRES 7-30-2020.

CLASS 9—ELECTRICAL AND SCIENTIFIC APPARATUS

FOR ELECTRONIC PUBLICATIONS, NAMELY, BOOKS, MAGAZINES, MANUALS AND JOURNALS RECORDED ON COMPUTER MEDIA, FEATURING LEGAL MATTERS; PRE-RECORDED VIDEOTAPES, VIDEO DISCS, DVDS AND OTHER PRE-RECORDED MEDIA, NAMELY, PRE-RECORDED ELECTRONIC AND DIGITAL MEDIA, FEATURING LEGAL MATTERS; PRE-RECORDED RECORDS, NAMELY, PHONOGRAPH RECORDS, PRE-RECORDED CASSETTES, NAMELY, AUDIO CASSETTES AND VIDEO CASSETTES, AND COMPACT DISCS, FEATURING LEGAL MATTERS; PROJECTION FILM, NAMELY, MOTION PICTURE FILMS FEATURING LEGAL MATTERS; PHOTOGRAPHIC SLIDES; SLIDE FILM MOUNTS (U.S. CLS. 21, 23, 26, 36 AND 38).

CLASS 16—PAPER GOODS AND PRINTED MATTER

FOR PRINTED MATTER, NAMELY, PAPER SIGNS, BOOKS, MANUALS, CURRICULUM, NEWSLETTERS, INFORMATIONAL CARDS AND BROCHURES, IN THE FIELD OF LEGAL MATTERS; STATIONERY (U.S. CLS. 2, 5, 22, 23, 29, 37, 38 AND 50).

CLASS 35—ADVERTISING AND BUSINESS

FOR BUSINESS RESEARCH SERVICES, NAMELY, PROVIDING ANALYSIS OF BUSINESS STRATEGIES, AND CONSULTANCY SERVICES REGARDING BUSINESS STRATEGIES, NAMELY, TAX CONSULTANCY; PREPARING STATEMENTS OF ACCOUNTS, AUDITING STATEMENTS OF ACCOUNTS AND CERTIFYING STATEMENTS OF ACCOUNTS, NAMELY, ACCOUNTANCY SERVICES; BUSINESS MANAGEMENT AND BUSINESS MANAGEMENT ASSISTANCE; ADVISORY SERVICES RELATING TO BUSINESS RISK MANAGEMENT; CONSULTANCY SERVICES REGARDING BUSINESS STRATEGIES AND BRANDING STRATEGIES; BUSINESS CONSULTATION SERVICES; DOCUMENT REPRODUCTION; FILING OF DOCUMENTS OR ELECTROMAGNETIC RECORDED MEDIA; OFFERING BUSINESS MANAGEMENT ASSISTANCE, NAMELY, MANAGEMENT AND OPERATION ASSISTANCE TO COMMERCIAL BUSINESSES, REGARDING OPERATION OF COMPUTERS, TYPEWRITERS OR OTHER OFFICE MACHINES AND EQUIPMENT (U.S. CLS. 100, 101 AND 102).

CLASS 36—INSURANCE AND FINANCIAL

FOR DEBT MANAGEMENT SERVICES AND DEBT COLLECTION AGENCIES (U.S. CLS. 100, 101 AND 102).

CLASS 41—EDUCATION AND ENTERTAINMENT

FOR TEACHING, IN THE FIELD OF LEGAL MATTERS; ARRANGING, ORGANIZING AND CONDUCTING SEMINARS IN THE FIELD OF LEGAL MATTERS; ARRANGING, ORGANIZING AND CONDUCTING SYMPOSIA IN THE FIELD OF LEGAL MATTERS; ARRANGING, ORGANIZING AND CONDUCTING LECTURES IN THE FIELD OF LEGAL MATTERS; PUBLISHING THE NON-PUBLICITY TEXTS OF OTHERS FEATURING LEGAL INFORMATION; PUBLISHING OF ELECTRONIC PUBLICATIONS, NAMELY, BOOKS AND ON-LINE JOURNALS, NAMELY, BLOGS FEATURING LEGAL MATTERS; TRANSLATION SERVICES; LANGUAGE INTERPRETING; VIDEO PRODUCTION SERVICES FOR EDUCATIONAL AND CULTURAL PURPOSES, EXCLUDING VIDEOS FOR USE IN MOVIES, TELEVISION PROGRAMS AND ADVERTISEMENTS (U.S. CLS. 100, 101 AND 107).

CLASS 45—PERSONAL AND LEGAL SERVICES

FOR LEGAL SERVICES FOR LAWSUITS AND OTHER LEGAL MATTERS; LEGAL CONSULTATION IN THE AREA OF CORPORATE, MERGERS AND ACQUISITIONS, FINANCE, CORPORATE GOVERNANCE, COMPLIANCE, RESTRUCTURING, INSOLVENCY, INTELLECTUAL PROPERTY, INFORMATION TECHNOLOGY, ENTERTAINMENT, TAX, DISPUTE RESOLUTION, REAL ESTATE, ANTITRUST, ENVIRONMENTAL LAW, EMPLOYMENT AND LABOR, OVERSEAS SUPPORT SERVICES, CHINESE LAW AND PRO BONO; LEGAL CONSULTING AND LEGAL SERVICES IN THE FIELD OF CORPORATE, MERGERS AND ACQUISITIONS, FINANCE, CORPORATE GOVERNANCE, COMPLIANCE, RESTRUCTURING, INSOLVENCY, INTELLECTUAL PROPERTY, INFORMATION TECHNOLOGY, ENTERTAINMENT, TAX, DISPUTE RESOLUTION, REAL ESTATE, ANTITRUST, ENVIRONMENTAL LAW, EMPLOYMENT AND LABOR, OVERSEAS SUPPORT SERVICES, CHINESE LAW AND PRO BONO; LEGAL SERVICES, NAMELY, PROVIDING PROXY OR AGENCY SERVICES FOR LEGAL MATTERS CONCERNING CONTRACTS; LEGAL SERVICES, NAMELY, PROVIDING PROXY SERVICES FOR LEGAL MATTERS CONCERNING REGISTRATION OR DEPOSITION PROCEDURES; LEGAL SERVICES, NAMELY, CONSULTING ON OR ACTING AS PROXY FOR ADMINISTRATIVE LEGAL PROCEDURES; LEGAL SERVICES, NAMELY, PROVIDING PROXY SERVICES FOR LEGAL APPRAISAL PROCEDURES AND OTHER RELATED SERVICES CONCERNING INDUSTRIAL PROPERTY RIGHTS, NAMELY, PATENTS, COPYRIGHTS OR OTHER INTELLECTUAL PROPERTY RIGHTS; LEGAL SERVICES, NAMELY, PROVIDING PROXY FOR SOCIAL INSURANCE PROCEDURES; ARBITRATION SERVICES; MEDIATION; PROVIDING INFORMATION ON LAWS; LEGAL RESEARCH; PROVIDING INFORMATION, NAMELY, SERVICE OF ACTUAL LEGAL NOTICE, PUBLISHED IN NEWSPAPERS AND MAGAZINES; LEGAL SERVICES, NAMELY, EXECUTING WILLS AND TESTAMENTS; LEGAL SERVICES, NAMELY, ARRANGING IN THE NATURE OF PREPARING AND DRAFTING WILLS AND TESTAMENTS; LEGAL SERVICES, NAMELY, ACTING AS CUSTODIAN IN THE NATURE OF SERVING AS EXECUTORS AND ATTORNEYS, FOR WRITTEN WILLS AND TESTAMENTS; LEGAL SERVICES, NAMELY, CONSULTING IN THE FIELD OF PERSONAL LEGAL AFFAIRS; CONDUCTING BACKGROUND INVESTIGATIONS (U.S. CLS. 100 AND 101).

LIEF MARTIN, EXAMINING ATTORNEY

CLASS 6—METAL GOODS

FOR UNWROUGHT AND PARTLY WROUGHT COMMON METALS AND THEIR ALLOYS; ALUMINIUM AND ALUMINIUM ALLOYS; MAGNESIUM AND MAGNESIUM ALLOYS, ZIRCONIUM AND ZIRCONIUM ALLOYS, COPPER AND COPPER ALLOYS; ALL THE AFORESAID IN THE FORM OF SHEETS, INGOTS, WAFFLE INGOTS, BILLETS, PLATES, STRIPS, FOILS, LAMINATES, FLAKES, GRANULES, MOULDS, RODS, TUBES, FLEXIBLE TUBES, WIRES, EXTRUDED SHAPED SECTIONS, SLABS, CASTINGS, EXTRUDED BARS, FORGINGS, PANELS, CONTAINERS, PRESSURE CONTAINERS, CYLINDERS FOR PRESSURISED GASES; RAILROADS AND TRAMWAYS, NAMELY, METALLIC MATERIAL FOR RAILROAD AND TRAMWAY TRACKS (U.S. CLS. 2, 12, 13, 14, 23, 25 AND 50).

CLASS 12—VEHICLES

FOR ENGINES FOR LAND VEHICLES; CHASSIS AND BODIES ALL FOR VEHICLES FOR LOCOMOTION BY LAND, SEA OR AIR; STRUCTURAL PARTS AND FITTINGS FOR ALL THE AFORESAID GOODS; STRUCTURAL COMPONENTS FOR VEHICLES, NAMELY, FOR AIRCRAFT, AUTOMOBILES, BUSES, TRUCKS, TRAILERS, RAILWAY ENGINES, RAILWAY ROLLING STOCK, AND TRAMS, PARTICULARLY CHASSIS, BODIES, HOUSINGS AND MAJOR STRUCTURAL MEMBERS SUCH AS WINDOWS, DOORS, BEAMS, PANELS, CLADDINGS, CEILINGS, ROOFING, FLOORING AND SOFFITS; NON-METALLIC INTERNAL STRUCTURAL COMPONENTS FOR AIRCRAFT, AUTOMOBILES, BUSES, TRUCKS, TRAILERS, RAILWAY CARS, RAILWAY ENGINES AND RAILWAY ROLLING STOCK, AND TRAMS, NAMELY, STRUCTURAL MEMBERS SUCH AS WINDOWS, DOORS, BEAMS, PANELS MADE TO ORDER, PANELS SOLD AS BLANKS, CLADDINGS, CEILING, ROOFING, FLOORING AND SOFFITS (U.S. CLS. 19, 21, 23, 31, 35 AND 44).

CLASS 19—NON-METALLIC BUILDING MATERIALS

FOR LAMINATES, NAMELY, NON METALLIC LAMINATE FLOORING; NON-METALLIC BUILDING MATERIALS, NAMELY, RIGID MOLDED TUBES, NON-INSULATING RIGID TUBES AND RODS; BUILDING MATERIALS, NAMELY, COMPOSITE PANELS COMPOSED PRIMARILY OF NON-METAL MATERIALS (U.S. CLS. 1, 12, 33 AND 50).

LIEF MARTIN, EXAMINING ATTORNEY

SN 79-091,759. LUXFER GAS CYLINDERS LIMITED, UNITED KINGDOM, FILED 8-27-2010.

SN 79-091,787. FRANCO BIZZARO SRL, ITALY, FILED 11-10-2010.

**FRANCO BIZZARO FB**

THE MARK CONSISTS OF STANDARD CHARACTERS WITHOUT CLAIM TO ANY PARTICULAR FONT, STYLE, SIZE, OR COLOR.

PRIORITY DATE OF 10-12-2010 IS CLAIMED.

OWNER OF INTERNATIONAL REGISTRATION 1062989 DATED 11-10-2010, EXPIRES 11-10-2020.

THE NAME(S), PORTRAIT(S), AND/OR SIGNATURE(S) SHOWN IN THE MARK IDENTIFIES "FRANCO BIZZARO", WHOSE CONSENT(S) TO REGISTER IS MADE OF RECORD.

THE WORDING "FB" HAS NO MEANING IN A FOREIGN LANGUAGE.

PRIORITY DATE OF 5-7-2010 IS CLAIMED.
OWNER OF INTERNATIONAL REGISTRATION 1062861 DATED 8-27-2010, EXPIRES 8-27-2020.

THE MARK CONSISTS OF TWO CURVED DIAGONAL BANDS SUPERIMPOSED ON A SQUARE BACKGROUND.

CLASS 18—LEATHER GOODS

FOR UMBRELLA RINGS, HARNESSES AND SADDLERY, FRAMES FOR UMBRELLAS OR PARASOLS, NAMELY, UMBRELLA AND PARASOL RIBS, UMBRELLA STICKS, FRAMES FOR UMBRELLAS OR PARASOLS, HORSE COLLARS, HORSE BLANKETS, MUZZLES, COLLARS FOR ANIMALS, UMBRELLAS, PARTS OF RUBBER FOR STIRRUPS, STIRRUP LEATHERS STRAPS, WHIPS, FEED BAGS FOR ANIMALS, UMBRELLA COVERS, HORSE FLANKS AND SHANKS, NAMELY, HORSE PROTECTIVE PADDING, BRACES, AND LEG BOOTS FOR THE FLANKS AND LEGS; CLOTHING FOR PETS, COVERS FOR ANIMALS, HARNESS FOR ANIMALS, BACKPACKS, PARASOLS, UMBRELLA HANDLES, REINS, ATTACHÉ CASES, HANDBAGS, TRAVELLING BAGS, RIDING SADDLES, SADDLERY, DOG COLLARS, COVERS FOR HORSE-SADDLES, FURNITURE COVERINGS OF LEATHER, PADS FOR HORSE SADDLES, STIRRUPS, HORSESHOES (U.S. CLS. 1, 2, 3, 22 AND 41).

CLASS 20—FURNITURE AND ARTICLES NOT OTHERWISE CLASSIFIED

FOR STUFFED ANIMALS, BEDS FOR HOUSEHOLD PETS, NESTING BOXES FOR HOUSEHOLD PETS, KENNELS FOR HOUSEHOLD PETS, BENCHES, COTS, CRADLES, SIDEBOARDS, ARTIFICIAL BEEHIVE HONEYCOMBS, FURNITURE, CHAIRS, SEATS, EASY CHAIRS, DOG KENNELS, ARMCHAIRS, FURNITURE, NAMELY, SALES AND DISPLAY COUNTERS, TABLES; CUSHIONS, MATTRESSES, VATS NOT OF METAL, DIVANS, SCHOOL FURNITURE, CURTAIN HOLDERS NOT OF TEXTILE MATERIAL, BEDS, HAND-OPERATED NON-MECHANICAL REELS NOT OF METAL FOR FLEXIBLE HOSES; PET, PLASTIC AND WOOD CRATES, FURNITURE OF METAL, RATTAN, FURNITURE NON-METAL CASTERS, NOT OF METAL LECTERNS, DECORATIVE MOBILES, DESKS, PILLOWS, INFLATABLE PILLOWS, STRAW MATTRESSES, UMBRELLA STANDS, BEAD CURTAINS FOR DECORATION, PROTECTIVE PLASTIC HOOF PADS FOR HORSES FOR THE PROTECTION OF THE UNDERSIDE OF HORSES' HOOFS; SOFAS, SPRING MATTRESSES, DECK CHAIRS, NON-METAL TRESTLES FOR SUPPORTING TABLES, AIR MATTRESSES FOR USE WHEN CAMPING, FURNITURE; DINNER WAGONS; SLEEPING BAGS FOR CAMPING, FOOTSTOOLS, STOOLS, POLES, NOT OF METAL, BASKETS, NOT OF METAL, NAMELY, BAKER'S BREAD BASKETS AND BASKETS FOR TRANSPORTING GOODS FOR COMMERCIAL PURPOSES; LETTER BOXES, NOT OF METAL OR MASONRY, BAMBOO CURTAINS, CHESTS FOR TOYS, SAW HORSES, SCRATCHING POSTS FOR CATS, SHOULDER POLES, WIND CHIMES, WOVEN TIMBER WINDOW BLINDS, BOOK RESTS, PET CUSHIONS, INDOOR WINDOW BLINDS, TOWEL CLOSETS (U.S. CLS. 2, 13, 22, 25, 32 AND 50).

CLASS 24—FABRICS

FOR FABRIC OF IMITATION ANIMAL SKINS; UP-HOLSTERY FABRICS; BATH LINEN; BOLTING CLOTH, BUCKRAM, LINEN LINING FABRIC FOR SHOES, FABRIC TABLE RUNNERS, OILCLOTH FOR USE AS TABLECLOTHS, FELTS, BED COVERS, QUILTS, MATTRESS COVERS, FUTON TICKS, NAMELY, UNSTUFFED FUTON COVERS NOT OF PAPER, BED COVERS OF PAPER, TABLECLOTHS NOT OF PAPER, TRAVELLING RUGS, TEXTILE USED AS LINING FOR CLOTHING, TEXTILE FABRICS FOR THE MANUFACTURE OF CLOTHING, BED SHEETS, SHROUDS, CLOTH BUNTING, FELT AND NON-WOVEN TEXTILE FABRICS, NAMELY, DRUGGET, DOWN COVERLETS, NAMELY, EIDERDOWNS, CURTAIN TIE-BACKS IN THE NATURE OF TEXTILE CURTAIN HOLDERS, TOWELS, TRACED CLOTHS FOR EMBROIDERY, FUSTIAN, WASHING MITTS, COVERS FOR FURNITURE, BED LINEN, DIAPERED LINEN, HOUSEHOLD LINEN, TOWELS OF TEXTILE, FURNITURE COVERINGS OF PLASTIC, TABLE NAPKINS OF TEXTILE, SERVIETTES

OF TEXTILE, HANDKERCHIEFS OF TEXTILE, PILLOWCASES, DOOR CURTAINS, CURTAINS OF TEXTILE OR PLASTIC, CURTAINS MADE OF NET, CALICO, TABLE LINEN COASTERS, TABLEMATS NOT OF PAPER, NON-WOVEN TEXTILE FABRICS FOR THE MANUFACTURE OF CLOTHING, TISSUE OF TEXTILE FOR REMOVING MAKE-UP, WALL HANGINGS OF TEXTILE, PLACE MATS, NOT OF PAPER, BED BLANKETS, UNFITTED FABRIC FURNITURE COVERS, FITTED TOILET LID COVERS OF FABRIC, SHOWER CURTAINS OF TEXTILE OR PLASTIC (U.S. CLS. 42 AND 50).

CLASS 28—TOYS AND SPORTING GOODS

FOR TOYS FOR DOMESTIC PETS (U.S. CLS. 22, 23, 38 AND 50).
LOURDES AYALA, EXAMINING ATTORNEY

SN 79-092,121, TONI GARD FASHION GMBH, FED REP GERMANY, FILED 11-4-2010.

Förster & Johnsen

THE MARK CONSISTS OF STANDARD CHARACTERS WITHOUT CLAIM TO ANY PARTICULAR FONT, STYLE, SIZE, OR COLOR.

PRIORITY DATE OF 5-20-2010 IS CLAIMED.
OWNER OF INTERNATIONAL REGISTRATION 1063889 DATED 11-4-2010, EXPIRES 11-4-2020.

CLASS 3—COSMETICS AND CLEANING PREPARATIONS

FOR PERFUMERY; COSMETICS; ESSENTIAL OILS; PRODUCTS FOR BODY AND BEAUTY CARE, NAMELY, SOAPS, SHOWER GEL, SHAMPOOS, PERSONAL DEODORANTS, LOTIONS FOR COSMETIC PURPOSES, COSMETIC SKIN CREAMS, COSMETIC SUN-TANNING PREPARATIONS, AND NON-MEDICATED PREPARATIONS FOR THE CARE OF SKIN, HAIR AND SCALP; HAIR LOTIONS; DENTIFRICES (U.S. CLS. 1, 4, 6, 50, 51 AND 52).

CLASS 14—JEWELRY

FOR JEWELLERY; WATCHES; COSTUME JEWELLERY; CUFFLINKS; TIE PINS AND CLIPS; NECKLACES; EARRINGS; RINGS; BANGLES; BRACELETS; BROOCHES; WATCH CASES; KEY RINGS; ALL OF THE AFOREMENTIONED GOODS MADE OF PRECIOUS METALS AND THEIR ALLOYS AND PLATED THEREWITH (U.S. CLS. 2, 27, 28 AND 50).

CLASS 18—LEATHER GOODS

FOR UMBRELLAS AND PARASOLS; GOODS MADE OF LEATHER AND IMITATION LEATHER, NAMELY, BAGS, TRUNKS, SUITCASES, PURSES, WALLETS, KEY BAGS, HAND BAGS, AND BRIEFCASES; GOODS NOT MADE OF LEATHER, NAMELY, TRUNKS, SUITCASES, PURSES, WALLETS, KEY BAGS, HAND BAGS, AND BRIEFCASES (U.S. CLS. 1, 2, 3, 22 AND 41).
DAWN HAN, EXAMINING ATTORNEY

SN 79-092,133. ANDREAS EPSTEIN, 80538 MÜNCHEN, FED REP GERMANY, FILED 8-23-2010.

SN 79-092,228. ALEXANDER WEIS, FED REP GERMANY, FILED 10-27-2010.



PRIORITY DATE OF 2-23-2010 IS CLAIMED.
OWNER OF INTERNATIONAL REGISTRATION 1063919
DATED 8-23-2010, EXPIRES 8-23-2020.
THE WORD(S) "AEYO" HAS NO MEANING IN A
FOREIGN LANGUAGE

CLASS 7—MACHINERY

FOR BALL BEARINGS FOR SKATEBOARDS, INLINE SKATES, ROLLER SKATES AND KICKBOARDS (U.S. CLS. 13, 19, 21, 23, 31, 34 AND 35).

CLASS 12—VEHICLES

FOR APPARATUS FOR LOCOMOTION BY LAND, NAMELY, MOTORCYCLES, SCOOTERS, BICYCLES, MOUNTAIN BIKES; PARTS OF SCOOTERS AND BICYCLES, NAMELY, FRAMES, SADDLES, HANDLEBARS, HANDLEBAR STEMS, SADDLE PILLARS, BRACKETS, WHEELS, BOTTOM BRACKETS, PEDALS; ACCESSORIES FOR SCOOTERS AND BICYCLES, NAMELY, DRESS GUARDS FOR BICYCLES, CARRIERS IN THE NATURE OF BASKETS ADAPTED FOR BICYCLES, TRAINING WHEELS AND BICYCLE STANDS, BELLS, AIR PUMPS, PANNIERS BAGS, SAFETY SEATS FOR CHILDREN, SAFETY BARS AND PROTECTIVE COATINGS FOR CHAINS AND GEAR SHIFTS (U.S. CLS. 19, 21, 23, 31, 35 AND 44).

CLASS 25—CLOTHING

FOR CLOTHING, IN THE NATURE OF SPORTSWEAR, NAMELY, RAINWEAR; FOOTWEAR; HEADGEAR, IN PARTICULAR HATS, CAPS AND HEADBANDS; STOCKINGS; GLOVES AND SPATS, NAMELY, SHOE COVERS FOR USE WHEN WEARING SHOES (U.S. CLS. 22 AND 39).

CLASS 28—TOYS AND SPORTING GOODS

FOR GYMNASTIC AND SPORTING ARTICLES, NAMELY, INLINE SKATES, ROLLER SKATES, KICKBOARDS; SKATEBOARD WHEELS; AXLES AND SPACER RINGS FOR SKATEBOARDS, INLINE SKATES, ROLLER SKATES AND KICKBOARDS; PROTECTIVE PADDING FOR SKATEBOARDING, INLINE-SKATING AND ROLLER SKATING; WRIST GUARDS, KNEE GUARDS, ELBOW GUARDS AND PROTECTIVE GLOVES AS SPORTING ARTICLES, INCLUDED IN THIS CLASS; SPECIAL BAGS FOR SPORTS EQUIPMENT, NAMELY, BAGS SPECIALLY ADAPTED FOR SPORTS EQUIPMENT; WORKOUT APPARATUS AND SPORTING APPARATUS, NAMELY, INLINE SKATES, ROLLER SKATES AND KICKBOARDS (U.S. CLS. 22, 23, 38 AND 50).

MATTHEW EINSTEIN, EXAMINING ATTORNEY



BETH

PRIORITY DATE OF 9-9-2010 IS CLAIMED.
OWNER OF INTERNATIONAL REGISTRATION 1064141
DATED 10-27-2010, EXPIRES 10-27-2020.

THE MARK CONSISTS OF THE TERM "BETH" BELOW A DESIGN ELEMENT CONSISTING OF TWO CONCENTRIC CIRCLES, WITH THE INNERMOST CIRCLE BEING SHADED AND CONTAINING AN ARBITRARY DESIGN CONSISTING OF CURVED LINES RESEMBLING AN OUTLINED LETTER B AND WITH AN ARROW FORMING THE TIP OF THE MIDDLE HORIZONTAL LINE OF THE ARBITRARY DESIGN.

CLASS 6—METAL GOODS

FOR PREFABRICATED FILTER HOUSINGS, NAMELY, METAL FRAMEWORK STRUCTURES (U.S. CLS. 2, 12, 13, 14, 23, 25 AND 50).

CLASS 7—MACHINERY

FOR PNEUMATIC CONVEYORS MAINLY CONSISTING OF PRESSURE AND VACUUM GENERATORS, PIPELINES, DUST REMOVERS, DUST DISCHARGING APPARATUS; WASTE DISPOSAL INSTALLATIONS, NAMELY, FOOD WASTE DISPOSALS MAINLY CONSISTING OF PNEUMATIC CONVEYORS WITH PIPELINES AND VACUUM GENERATORS, WASTE COLLECTORS OF METAL OR PLASTIC AND WASTE GRINDERS FOR GARBAGE; DUST EXHAUSTING AND REMOVING INSTALLATIONS AND DE-DUSTING MACHINES CONSISTING OF DUST EXHAUSTING APPARATUS, NAMELY, VACUUM CLEANERS CONTAINING VACUUM NOZZLES WITH TUBES, PIPELINES, DUST REMOVERS AND VACUUM GENERATORS FOR INDUSTRIAL PURPOSES; ELECTRIC DUST REMOVING APPARATUS, NAMELY, VACUUM CLEANERS; ELECTRIC VACUUM CLEANERS; ELECTRICAL WATER PUMPS FOR WETTING DUST IN BUILDINGS (U.S. CLS. 13, 19, 21, 23, 31, 34 AND 35).

CLASS 11—ENVIRONMENTAL CONTROL APPARATUS

FOR VENTILATING INDUSTRIAL FANS; VENTILATION DEVICES, NAMELY, VENTILATING EXHAUST FANS, DRY AND WET ELECTROSTATIC PRECIPITATORS FOR CLEANING AIR (U.S. CLS. 13, 21, 23, 31 AND 34).

CLASS 37—CONSTRUCTION AND REPAIR

FOR MAINTENANCE AND REPAIR OF DUST EXHAUSTING AND DUST REMOVING EQUIPMENT, DE-DUSTING EQUIPMENT, DUST EXHAUSTING APPARATUS, DUST REMOVERS AND VACUUM GENERATORS, DUST REMOVING APPARATUS, VACUUM CLEANERS, DUST WETTERS, INDUSTRIAL FANS, PNEUMATIC CONVEYORS, PRESSURE AND VACUUM GENERATORS, DUST REMOVERS, DUST DISCHARGING APPARATUS, WASTE DISPOSAL EQUIPMENT, VACUUM GENERATORS, WASTE COLLECTORS AND WASTE GRINDERS (U.S. CLS. 100, 103 AND 106).

CLASS 42—SCIENTIFIC AND COMPUTER SERVICES

FOR TECHNICAL PLANNING, DEVELOPMENT AND DESIGN OF DUST EXHAUSTING AND DUST REMOVING EQUIPMENTS, DE-DUSTING EQUIPMENT DUST EXHAUSTING APPARATUS, DUST REMOVERS AND VACUUM GENERATORS, DUST REMOVING APPARATUS, VACUUM CLEANERS, DUST WETTERS, INDUSTRIAL FANS, PNEUMATIC CONVEYORS, PRESSURE AND VACUUM GENERATORS, DUST REMOVERS, DUST DISCHARGING APPARATUS, WASTE DISPOSAL EQUIPMENT, VACUUM GENERATORS, WASTE COLLECTORS AND WASTE GRINDERS (U.S. CLS. 100 AND 101).

KAREN SEVERSON, EXAMINING ATTORNEY

SN 79-092,256, HU VIBEKE SØRLIE/MONSTER FORMAT AS, OSLO, NORWAY, FILED 8-18-2010.



PRIORITY DATE OF 6-8-2010 IS CLAIMED.
OWNER OF INTERNATIONAL REGISTRATION 1064194 DATED 8-18-2010, EXPIRES 8-18-2020.
NO CLAIM IS MADE TO THE EXCLUSIVE RIGHT TO USE "ULTIMATE ENTERTAINER", APART FROM THE MARK AS SHOWN.

THE COLOR(S) BLACK, WHITE, GRAY AND PINK IS/ARE CLAIMED AS A FEATURE OF THE MARK.

THE MARK CONSISTS OF THE STYLIZED WORDING "THE ULTIMATE ENTERTAINER" IN BLACK, SUPERIMPOSED OVER A GLOBE. THE CONTINENTS ARE WHITE, PINK AND BLACK AND APPEAR TO BE LIGHTED AREAS WITHIN A GRID COVERING THE GLOBE. THE OCEANS ARE GRAY AND BLACK, AND APPEAR TO BE UNLIT. THE GLOBE FEATURES A PAIR OF HEADPHONES AND IS BACKLIT, WITH THE STRONGEST AREA OF LIGHT APPEARING TO THE UPPER LEFT. THE AREA AROUND THE GLOBE IS PINK, WHITE AND GRAY. THE GLOBE DESIGN APPEARS IN THE CENTER OF A BLACK SQUARE.

CLASS 9—ELECTRICAL AND SCIENTIFIC APPARATUS

FOR EXPOSED CINEMATOGRAPHIC FILMS; VIDEO DISCS AND VIDEO TAPES WITH RECORDED ANIMATED CARTOONS; PRERECORDED VIDEO TAPES FEATURING MUSIC FILMS; DOWNLOADABLE FILMS AND MOVIES FEATURING MUSIC PROVIDED VIA A VIDEO-ON-DEMAND SERVICES; COMPACT DISCS, VIDEO DISCS, AND CD-ROMS, ALL OF THE FOREGOING FEATURING MUSIC; ENTERTAINMENT APPARATUS FOR USE WITH TELEVISION RECEIVERS, NAMELY, A PORTABLE KARAOKE PLAYER AND RECORDER FEATURING A VIDEO RECORDER, MONITOR AND MICROPHONE; ELECTRONIC PUBLICATIONS, NAMELY BOOKS AND MAGAZINES RECORDED ON COMPUTER MEDIA, FEATURING MUSICAL SCORES AND COMPOSITIONS; ELECTRONIC VIDEO GAME CONSOLES ADAPTED FOR USE WITH AN EXTERNAL DISPLAY SCREEN OR MONITOR; INTERACTIVE GAMES FOR USE WITH TELEVISION RECEIVERS; INTERACTIVE VIDEO GAMES OF VIRTUAL REALITY COMPRISED OF COMPUTER HARDWARE FOR USE WITH AN EXTERNAL MONITOR AND SOFTWARE; TELEPHONES; CELL PHONES; BATTERY CHARGERS; BATTERY CHARGERS FOR CELL PHONES; HANDS-FREE DEVICES FOR MOBILE PHONES; DOWNLOADABLE ELECTRONIC GAMES FOR MOBILE PHONES; KARAOKE MACHINES (U.S. CLS. 21, 23, 26, 36 AND 38).

CLASS 16—PAPER GOODS AND PRINTED MATTER

FOR PRINTED MATTER, NAMELY, CALENDARS, AND BROCHURES AND NON-FICTION BOOKS ON THE SUBJECTS OF ARTISTS AND MUSIC; BOOK BINDING MATERIAL; PHOTOGRAPHS; STATIONERY; ADHESIVES FOR STATIONERY OR HOUSEHOLD PURPOSES; PRINTERS' TYPE; PRINTING BLOCKS (U.S. CLS. 2, 5, 22, 23, 29, 37, 38 AND 50).

CLASS 25—CLOTHING

FOR CLOTHING, NAMELY, PANTS, T-SHIRTS, JACKETS; FOOTWEAR; HEADWEAR (U.S. CLS. 22 AND 39).

CLASS 28—TOYS AND SPORTING GOODS

FOR GAMES AND PLAYTHINGS, NAMELY, BOARD GAMES, DOLLS, TOY ACTION FIGURES; CHRISTMAS TREE DECORATIONS EXCEPT ILLUMINATIONS AND CONFECTIONERY (U.S. CLS. 22, 23, 38 AND 50).

CLASS 38—COMMUNICATION

FOR TELECOMMUNICATIONS SERVICES, NAMELY, TELEVISION AND RADIO BROADCASTING (U.S. CLS. 100, 101 AND 104).

CLASS 41—EDUCATION AND ENTERTAINMENT

FOR ENTERTAINMENT SERVICES, NAMELY ON-GOING TELEVISION TALENT SHOWS AND ON-GOING TELEVISION SHOWS FEATURING ENTERTAINMENT NEWS, TELEVISION CLIPS AND CELEBRITY INTERVIEWS; MULTIMEDIA ENTERTAINMENT SERVICES, NAMELY, DEVELOPMENT AND PRODUCTION OF COMMERCIAL FILMS, TELEFILMS, CINEMATOGRAPHIC FILMS, AND TELEVISION PROGRAMS (U.S. CLS. 100, 101 AND 107).

JERI J. FICKES, EXAMINING ATTORNEY

SN 79-092,432. LUFTHANSA TECHNIK AG, FED REP GERMANY, FILED 8-12-2010.

nicemate

THE MARK CONSISTS OF STANDARD CHARACTERS WITHOUT CLAIM TO ANY PARTICULAR FONT, STYLE, SIZE, OR COLOR.

PRIORITY DATE OF 7-7-2010 IS CLAIMED.
OWNER OF INTERNATIONAL REGISTRATION 1064736 DATED 8-12-2010, EXPIRES 8-12-2020.
OWNER OF U.S. REG. NO. 3,488,796.

CLASS 9—ELECTRICAL AND SCIENTIFIC APPARATUS

FOR APPARATUS FOR RECORDING AND REPRODUCING SOUND AND IMAGES, FOR USE IN AIRCRAFT, IN AIRCRAFT MAINTENANCE, AND IN EQUIPPING THE CABINS OF AIRCRAFT FOR ENTERTAINMENT AND CABIN MANAGEMENT PURPOSES; COMPUTER HARDWARE FOR THE INPUT, STORAGE, PROCESSING, TRANSMISSION, AND OUTPUT OF DATA, FOR USE IN AIRCRAFT, IN AIRCRAFT MAINTENANCE, AND IN EQUIPPING THE CABINS OF AIRCRAFT FOR ENTERTAINMENT AND CABIN MANAGEMENT PURPOSES; COMPUTER SOFTWARE FOR THE COLLECTION, EDITING, ORGANIZING, MODIFYING, BOOK MARKING, TRANSMISSION, STORAGE AND SHARING OF DATA, FOR USE IN AIRCRAFT, IN AIRCRAFT MAINTENANCE, AND IN EQUIPPING THE CABINS OF AIRCRAFT FOR ENTERTAINMENT AND CABIN MANAGEMENT PURPOSES (U.S. CLS. 21, 23, 26, 36 AND 38).

CLASS 37—CONSTRUCTION AND REPAIR

FOR INSTALLATION, MAINTENANCE, AND REPAIR OF AIRCRAFT AND AIRCRAFT PARTS AND FITTINGS, AIRCRAFT ELECTRICAL SYSTEMS AND ELECTRONIC APPARATUS, AIRCRAFT DATA PROCESSING EQUIPMENT, AND AIRCRAFT COMPUTER HARDWARE, ALL FOR USE IN AIRCRAFT CABINS FOR ENTERTAINMENT AND CABIN MANAGEMENT PURPOSES (U.S. CLS. 100, 103 AND 106).

CLASS 42—SCIENTIFIC AND COMPUTER SERVICES

FOR DESIGN AND DEVELOPMENT OF COMPUTER HARDWARE AND SOFTWARE FOR USE IN AEROPLANES FOR ENTERTAINMENT, MAINTENANCE, AND CABIN MANAGEMENT PURPOSES; PLATFORM AS A SERVICE (PAAS) FEATURING COMPUTER SOFTWARE PLATFORMS ON THE INTERNET FOR DATA PROCESSING, DATABASE MANAGEMENT, AND DIAGNOSTICS, FOR USE IN THE REPAIR, MAINTENANCE, MONITORING, SERVICING, AND UPGRADING OF AEROPLANES (U.S. CLS. 100 AND 101).

NELSON SNYDER, EXAMINING ATTORNEY

SN 79-094,143. SHIMANO EUROPE B.V., NETHERLANDS, FILED 1-10-2011.

PRO THARSIS

THE MARK CONSISTS OF STANDARD CHARACTERS WITHOUT CLAIM TO ANY PARTICULAR FONT, STYLE, SIZE, OR COLOR.

PRIORITY DATE OF 7-13-2010 IS CLAIMED.
OWNER OF INTERNATIONAL REGISTRATION 1068648 DATED 1-10-2011, EXPIRES 1-10-2021.

NO CLAIM IS MADE TO THE EXCLUSIVE RIGHT TO USE "PRO", APART FROM THE MARK AS SHOWN.

CLASS 9—ELECTRICAL AND SCIENTIFIC APPARATUS

FOR BICYCLE COMPUTERS, BICYCLE ERGOMETERS, PROTECTIVE HELMETS, PROTECTIVE HELMETS FOR SPORTS; PROTECTIVE HELMETS FOR BICYCLISTS; SPECTACLES, SPORTS SPECTACLES, SUN GLASSES, EYE WEAR, EYE WEAR ACCESSORIES, NAMELY, SPECTACLE CORDS AND SPECTACLE CASES; SPEED INDICATORS, DISTANCE INDICATORS; HEART RATE MONITORS (U.S. CLS. 21, 23, 26, 36 AND 38).

CLASS 12—VEHICLES

FOR BICYCLES, BICYCLE PARTS AND BICYCLE ACCESSORIES, NAMELY, TYRES, BAR ENDS, TUBE PROTECTORS, TUBE SADDLE BAGS, BASKETS ADAPTED FOR CYCLES, BICYCLE CARRIERS, BICYCLE RACKS, FRAMES, CHAINS, CHAIN GUARDS, HUBS, LUGGAGE CARRIERS, EXTENDERS FOR LUGGAGE CARRIERS, PEDALS, PUMPS, PUMP HOSES, BRAKES, SPEEDS, CARRIER STRAPS, SPOKES, MUDGUARDS, MUDFLAPS, REARVIEW MIRRORS, HANDLEBARS, BICYCLE STANDS, HANDLEBAR EXPANDERS, HANDLEBAR RIBBONS, HANDLEBAR PINS, TUBE HOLDERS, TUBES, RIMS, FLAPS, FOOT HOOKS, FOOT PUMPS, FOOT SUPPORTS, FORKS, FREEWHEELS, WHEELS, BICYCLE CARRIERS FOR AUTOMOBILES, SADDLE CUSHIONS, SADDLE PIN BOLTS, SADDLE PINS, BOLT SETS, CRANK BOLTS, FILLING RINGS, CHAIN CLEANERS, SADDLES, SIDE WHEELS, BRAKE HANDLES, HANDLEBAR ADJUSTERS, BELLS, CHILD SEATS FOR BICYCLE, CHAIN-STAY PROTECTORS, CHAIN DEFLECTORS, SEAT PILLARS, SEAT PILLAR QUICK RELEASE, HEAD PARTS FOR FRAME FORK ASSEMBLY, SUSPENSION, HANDLEBAR STEMS, GRIPS FOR HANDLEBARS (U.S. CLS. 19, 21, 23, 31, 35 AND 44).

CLASS 25—CLOTHING

FOR CLOTHING, NAMELY, T-SHIRTS, POLO SHIRTS, COATS, JACKETS, UNDERWEAR; RAIN SUITS, RAINCOATS, RAIN PONCHOS; SPORTS CLOTHING, NAMELY, SPORTS SHIRTS, SPORTS PANTS, SPORTS SOCKS, THERMO SHIRTS AND THERMO PANTS; BICYCLE CLOTHING, NAMELY, BICYCLE SHIRTS, BICYCLE PANTS, BICYCLE PANTS WITH PADS, BICYCLE SOCKS; FOOTWEAR; OVERSHOES, BICYCLE SHOES, SMOCKS, BICYCLE RACING SHOES, WALKING SHOES, SHOE COVERS FOR USE WHEN WEARING SHOES; HEADGEAR, NAMELY, CAPS AND CYCLING CAPS; GLOVES, BICYCLE GLOVES, BICYCLE RACING GLOVES; SUSPENDERS, SOCKS, BICYCLE PANTS (U.S. CLS. 22 AND 39).

ALLISON HOLTZ, EXAMINING ATTORNEY

SN 79-094,864. RYTM-L SP. Z O.O., POLAND, FILED 12-28-2010.



OWNER OF INTERNATIONAL REGISTRATION 1070451 DATED 12-28-2010, EXPIRES 12-28-2020.

THE COLOR(S) YELLOW AND BLUE IS/ARE CLAIMED AS A FEATURE OF THE MARK.

THE MARK CONSISTS OF THE WORD "EXPERT" APPEARING IN YELLOW INSIDE A BLUE OVAL WITH THE YELLOW OUTLINE. ON THE TOP OF THE BLUE OVAL IS A YELLOW OVAL CONTAINING THE BLUE WORD "LINE". THE FIRST AND LAST LETTERS OF THE WORD "EXPERT" ARE CONNECTED WITH THE YELLOW OUTLINE.

CLASS 2—PAINTS

FOR PAINTS, LACQUERS, PRESERVATIVES, IN THE NATURE OF A COATING, AGAINST RUST AND AGAINST DETERIORATION OF WOOD IN AEROSOL FORM (U.S. CLS. 6, 11 AND 16).

CLASS 17—RUBBER GOODS

FOR PACKING, STOPPING AND INSULATING MATERIALS IN AEROSOL FORM, NAMELY, INSULATING MATERIALS, NAMELY, POLYURETHANE FOAM AND POLYETHYLENE FOAM, LOW-DENSITY POLYURETHANE PACKAGING FOAM, POLYURETHANE FOAM SHEETING FOR USE AS BUILDING INSULATION, SILICONE BASED SEALANTS AND ADHESIVES, SILICONE RUBBER, SILICONE-BASED SEALANTS AND ADHESIVES FOR CONSTRUCTION PARTICULARLY FOR USE IN GLAZING, SIDING AND TRIM, ADHESIVE SEALANTS FOR GENERAL USE, ACRYLIC BASED SEALANTS AND ADHESIVES, ACRYLIC-BASED SEALANTS AND ADHESIVES FOR CONSTRUCTION PARTICULARLY FOR USE IN GLAZING, SIDING AND TRIM, ADHESIVE SEALANT AND CAULKING COMPOUND, ADHESIVE SEALANTS FOR USE IN ROOFING, AIR DUCT ADHESIVE SEALANT COMPOUNDS FOR USE IN THE HEATING AND COOLING INDUSTRY, CONSTRUCTION MASTIC ADHESIVE FOR CEILING, WALL AND FLOOR TILES, WOOD PANEL AND ASPHALT, URETHANE-BASED SEALANTS AND ADHESIVES FOR CONSTRUCTION PARTICULARLY FOR USE IN GLAZING, SIDING AND TRIM (U.S. CLS. 1, 5, 12, 13, 35 AND 50).

CLASS 19—NON-METALLIC BUILDING MATERIALS

FOR NON-METALLIC BUILDING MATERIALS, NAMELY, ADHESIVE MORTAR FOR BUILDING PURPOSES, BITUMEN-BASED SEALANTS FOR ROOFING, MORTAR (U.S. CLS. 1, 12, 33 AND 50).
KATHERINE E. HALMEN, EXAMINING ATTORNEY

SN 79-095,571. CAROLINE RIJKSEN, CRANS-MONTANA, SWITZERLAND, AND LAURENT ZBINDEN, CRANS-MONANA, SWITZERLAND, FILED 2-18-2011.

DECHAMBY

THE MARK CONSISTS OF STANDARD CHARACTERS WITHOUT CLAIM TO ANY PARTICULAR FONT, STYLE, SIZE, OR COLOR.

PRIORITY DATE OF 8-20-2010 IS CLAIMED.
OWNER OF INTERNATIONAL REGISTRATION 1072550 DATED 2-18-2011, EXPIRES 2-18-2021.
THE WORDING "DECHAMBY" HAS NO MEANING IN A FOREIGN LANGUAGE.

CLASS 3—COSMETICS AND CLEANING PREPARATIONS

FOR PERFUMERY, SOAPS, COSMETICS (U.S. CLS. 1, 4, 6, 50, 51 AND 52).

CLASS 14—JEWELRY

FOR PRECIOUS METALS; JEWELRY, JEWELRY ARTICLES, NAMELY, RINGS OF PRECIOUS METAL, NECKLACES OF PRECIOUS METAL, BRACELETS OF PRECIOUS METAL AND TIE PINS OF PRECIOUS METAL; TIMEPIECES (U.S. CLS. 2, 27, 28 AND 50).

CLASS 18—LEATHER GOODS

FOR LEATHER AND IMITATION LEATHER, AND GOODS MADE OF LEATHER AND IMITATION LEATHER, NAMELY, BRIEFCASES, HANDBAGS, TRAVELING BAGS, UMBRELLAS, WALKING STICKS, SADDLERY (U.S. CLS. 1, 2, 3, 22 AND 41).

CLASS 21—HOUSEWARES AND GLASS

FOR GLASSWARE, NAMELY, BEVERAGE GLASSWARE AND GLASS VASES; PORCELAIN WARE, NAMELY, PLATES, BOWLS, CUPS, SAUCERS, SERVING PLATTERS, PITCHERS AND DISHES MADE OF PORCELAIN; EARTHENWARE MUGS AND PLATES FOR HOUSEHOLD AND KITCHEN USE (U.S. CLS. 2, 13, 23, 29, 30, 33, 40 AND 50).

CLASS 41—EDUCATION AND ENTERTAINMENT

FOR TEACHING IN THE FIELD OF VISUAL ARTS AND GRAPHIC ART DESIGN; CULTURAL ACTIVITIES, NAMELY, ORGANIZATION OF CULTURAL SHOWS (U.S. CLS. 100, 101 AND 107).
EVELYN BRADLEY, EXAMINING ATTORNEY

SN 79-095,662. JAMES JOHNSTON & COMPANY OF ELGIN LIMITED, UNITED KINGDOM, FILED 3-11-2011.



OWNER OF INTERNATIONAL REGISTRATION 1072745 DATED 3-11-2011, EXPIRES 3-11-2021.

THE COLOR(S) BLUE AND GOLD IS/ARE CLAIMED AS A FEATURE OF THE MARK.

THE MARK CONSISTS OF THE TERM "JOHNSTONSCASHMERE" WITH THE TERM "JOHNSTONS" IN BLUE AND THE TERM "CASHMERE" IN GOLD.
SEC. 2(F).

CLASS 24—FABRICS

FOR TEXTILE GOODS MADE IN WHOLE OR SUBSTANTIAL PART OF CASHMERE, NAMELY, TEXTILE FABRICS FOR MANUFACTURE OF CLOTHING, FOOTWEAR, HEADWEAR, CUSHIONS, AND CUSHION COVERS; TEXTILE GOODS MADE IN WHOLE OR SUBSTANTIAL PART OF CASHMERE, NAMELY, BED BLANKETS, BED COVERS, TRAVEL RUGS, NAMELY, LAP ROBES, TEXTILE WALL HANGINGS (U.S. CLS. 42 AND 50).

CLASS 25—CLOTHING

FOR CLOTHING MADE IN WHOLE OR SUBSTANTIAL PART OF CASHMERE, NAMELY, SWEATPANTS, SKIRTS, DRESSES, COATS, JACKETS, VESTS, WAISTCOATS, CAPES, SWEATERS, CARDIGANS, SOCKS, HOSIERY, SCARVES, SHAWLS, GLOVES, BELTS, TIES; FOOTWEAR MADE IN WHOLE OR SUBSTANTIAL PART OF CASHMERE, NAMELY, SLIPPERS; HEADGEAR MADE IN WHOLE OR SUBSTANTIAL PART OF CASHMERE, NAMELY, HATS, CAPS AND HEADBANDS (U.S. CLS. 22 AND 39).

JIM RINGLE, EXAMINING ATTORNEY

FLORENTINA BLANDU, EXAMINING ATTORNEY

SN 79-095,955. JE INTERNATIONAL GMBH, FED REP GERMANY, FILED 2-24-2011.

TRUE5STARS

THE MARK CONSISTS OF STANDARD CHARACTERS WITHOUT CLAIM TO ANY PARTICULAR FONT, STYLE, SIZE, OR COLOR.

PRIORITY DATE OF 8-30-2010 IS CLAIMED.

OWNER OF INTERNATIONAL REGISTRATION 1073462 DATED 2-24-2011, EXPIRES 2-24-2021.

SN 79-096,001. GENERADORES EUROPEOS, S.A.L., BERGONDO (A CORUÑA), SPAIN, FILED 12-16-2010.

CLASS 38—COMMUNICATION

FOR PROVIDING ACCESS TO DATABASES ON THE INTERNET (U.S. CLS. 100, 101 AND 104).

CLASS 43—HOTEL AND RESTAURANT SERVICES

FOR PROVIDING FOOD AND DRINK; PROVIDING TEMPORARY ACCOMMODATIONS; TRAVEL AGENCY SERVICES, NAMELY, MAKING RESERVATIONS AND BOOKINGS FOR TEMPORARY ACCOMMODATIONS; SERVICES FOR PROVIDING HOTELS AND ACCOMMODATION FOR OTHERS, NAMELY, PROVIDING INFORMATION REGARDING BOOKING AND PAYMENT INFORMATION IN CONNECTION WITH THE RESERVATION AND BOOKING OF ACCOMMODATION AND PROVIDING HOTEL REVIEWS BY TELEPHONE, FAX, POST, COURIER OR VIA COMPUTER NETWORKS AND GLOBAL COMMUNICATIONS NETWORKS; TRAVEL AGENCY SERVICES, NAMELY, MAKING RESERVATIONS AND BOOKINGS FOR RESTAURANTS AND MEALS; PROVIDING ACCOMMODATION INFORMATION, NAMELY, RATINGS OF THE QUALITY OF ACCOMMODATIONS WITH THE USE OF STARS, UNDER REVIEWS AND THE LIKE (U.S. CLS. 100 AND 101).
SHAILA SETTLES, EXAMINING ATTORNEY

SN 79-095,972. STRANGE LOVE PTY LTD, AUSTRALIA, FILED 1-13-2011.

DANA MATHERS

PRIORITY DATE OF 7-13-2010 IS CLAIMED.

OWNER OF INTERNATIONAL REGISTRATION 1073500 DATED 1-13-2011, EXPIRES 1-13-2021.

THE NAME(S), PORTRAIT(S), AND/OR SIGNATURE(S) SHOWN IN THE MARK IDENTIFIES DANA MATHERS, WHOSE CONSENT(S) TO REGISTER IS MADE OF RECORD.

CLASS 25—CLOTHING

FOR CLOTHING AND FASHION WEAR, NAMELY, DRESSES, BRIDAL DRESSES, EVENING WEAR DRESSES, COCKTAIL DRESSES, SKIRTS, BLOUSES, LINGERIE, CAMISOLES, JUMPERS, SHORTS, TROUSERS, PANTS, STOLIES, FASCINATORS, T-SHIRTS, SHIRTS, JACKETS, SUITS, COATS, JACKETS, PAJAMAS, SINGLET, SCARVES, BELTS, FOOTWEAR, NAMELY, SHOES, BOOTS, SANDALS AND SLIPPERS, AND HEADGEAR, NAMELY, HATS AND CAPS (U.S. CLS. 22 AND 39).

CLASS 42—SCIENTIFIC AND COMPUTER SERVICES

FOR DESIGN OF CLOTHING, FOOTWEAR, HEADGEAR, FASHION ACCESSORIES AND JEWELRY (U.S. CLS. 100 AND 101).



OWNER OF INTERNATIONAL REGISTRATION 1073561 DATED 12-16-2010, EXPIRES 12-16-2020.

THE COLOR(S) DARK BLUE AND LIGHT BLUE IS/ARE CLAIMED AS A FEATURE OF THE MARK.

THE MARK CONSISTS OF THE STYLIZED WORDING "GENESAL" APPEARING TO THE RIGHT OF THE DEPICTION OF A HEXAGON CONTAINING THREE INTERSECTING LINES. THE STYLIZED WORDING "GENESAL" APPEARS IN THE COLOR DARK BLUE. THE COLOR LIGHT BLUE APPEARS ON THE DEPICTION OF THE HEXAGON CONTAINING THREE INTERSECTING LINES.

CLASS 7—MACHINERY

FOR MACHINES AND MACHINE TOOLS, NAMELY, METALWORKING MACHINE TOOLS, MILLING CUTTERS, BROACHES, CHASERS, BELT SANDING MACHINES, MACHINES FOR MANUFACTURING SEMICONDUCTORS, METAL WORKING MACHINES; MOTORS OTHER THAN FOR LAND VEHICLES; MACHINE COUPLING AND TRANSMISSION COMPONENTS EXCLUDING THOSE FOR LAND VEHICLES; GENERATORS OF ELECTRICITY (U.S. CLS. 13, 19, 21, 23, 31, 34 AND 35).

CLASS 9—ELECTRICAL AND SCIENTIFIC APPARATUS

FOR ELECTRICAL CONDUCTORS; STATIC ENERGY CONVERTERS IN THE NATURE OF AN APPARATUS FOR CONVERTING STATIC ENERGY TO ELECTRICAL ENERGY, NAMELY, THERMOELECTRIC CONVERTERS, PHOTOVOLTAIC SOLAR MODULES; BATTERIES; ENERGY ACCUMULATORS, NAMELY, ELECTRIC ACCUMULATORS, BATTERIES; ELECTRIC BATTERIES; APPARATUS AND INSTRUMENTS FOR CONDUCTING, SWITCHING, TRANSFORMING, ACCUMULATING, REGULATING OR CONTROLLING ELECTRICITY, NAMELY, ELECTRIC CURRENT SWITCHES, ELECTRICAL RELAYS AND TRANSFORMERS, ELECTRICAL TRANSFORMERS, ELECTRIC ACCUMULATORS, ELECTRIC CONTROL PANELS, ELECTRICITY CONDUITS, ELECTRICITY LIMITERS, ELECTRICITY ADAPTERS (U.S. CLS. 21, 23, 26, 36 AND 38).

CLASS 35—ADVERTISING AND BUSINESS

FOR PROCUREMENT SERVICES FOR OTHERS, NAMELY, PURCHASING MACHINE TOOLS FOR THE GENERATION OF ELECTRICITY AND SPARE PARTS THEREFOR, ELECTRICITY GENERATORS, ELECTRICAL CONDUCTORS, BATTERIES, ENERGY ACCUMULATORS AND GENERATORS FOR THE PRODUCTION OF ELECTRICAL POWER; SALES PROMOTION FOR THIRD PARTIES; EXPORT AND IMPORT AGENCIES IN THE FIELD OF MACHINE TOOLS FOR THE GENERATION OF ELECTRICITY AND SPARE PARTS THEREFOR, ELECTRICITY GENERATORS, ELECTRICAL CONDUCTORS, BATTERIES, ENERGY ACCUMULATORS AND GENERATORS FOR THE PRODUCTION OF ELECTRICAL POWER; IMPORT-EXPORT AGENCIES IN THE FIELD OF ENERGY; ON-LINE WHOLESALE AND RETAIL STORE SERVICES FEATURING MACHINE TOOLS FOR THE GENERATION OF ELECTRICITY AND SPARE PARTS THEREFOR, ELECTRICITY GENERATORS, ELECTRICAL CONDUCTORS, BATTERIES, ENERGY ACCUMULATORS AND GENERATORS FOR THE PRODUCTION OF ELECTRICAL POWER; DEMONSTRATION OF GOODS; ADVERTISING; FRANCHISING SERVICES IN COMMERCIAL COMPANY OPERATIONAL OR MANAGEMENT ASSISTANCE, NAMELY, ASSISTANCE IN THE RUNNING OR MANAGEMENT OF INDUSTRIAL OR COMMERCIAL ENTERPRISES OF OTHERS; ORGANIZATION OF TRADE SHOWS AND EXHIBITIONS FOR COMMERCIAL OR ADVERTISING PURPOSES; COMMERCIAL BUSINESS MANAGEMENT, BUSINESS MANAGEMENT AND ORGANIZATION CONSULTANCY; PUBLICATION OF PUBLICITY TEXTS; PUBLIC RELATIONS (U.S. CLS. 100, 101 AND 102).

CLASS 40—MATERIAL TREATMENT

FOR TREATMENT OF MATERIALS, NAMELY, METAL TREATMENT, PAPER TREATMENT; RENTAL OF ELECTRIC POWER GENERATORS; CONSULTANCY SERVICES RELATING TO ENERGY PRODUCTION, NAMELY, CONSULTATION IN THE FIELD OF CUSTOM FABRICATION OF POWER GENERATION ENGINES, TECHNICAL CONSULTATION IN THE FIELD OF PRODUCTION OF SOLAR ENERGY, CONSULTING SERVICES IN THE FIELD OF PRODUCTION OF WIND ENERGY, PROVISION OF ADVICE AND CONSULTANCY IN RELATION TO THE PRODUCTION OF ENERGY, AND THE TREATMENT, RECYCLING, TRANSFORMATION AND INCINERATION OF WASTE; CUSTOM ASSEMBLING OF MATERIALS FOR OTHERS, NAMELY, ASSEMBLY OF PRODUCTS FOR OTHERS; PROVIDING MATERIAL TREATMENT INFORMATION; PARTS TOOLING SERVICES, NAMELY, MACHINING PARTS FOR OTHERS, METAL PARTS FABRICATION AND FINISHING SERVICES FOR OTHERS, FORGING OF METAL GOODS TO THE ORDER AND SPECIFICATION OF OTHERS; PRODUCTION OF ENERGY; GENERATION OF ELECTRICAL ENERGY FROM COMBUSTION OF SOLID WASTE, SOLAR ENERGY, WIND ENERGY, HYDRAULIC AND PHOTOVOLTAIC ENERGY (U.S. CLS. 100, 103 AND 106).

MICHAEL TANNER, EXAMINING ATTORNEY

SN 79-096,273. IASSET PTY LTD, AUSTRALIA, FILED 2-9-2011.

iasset  **com**

OWNER OF INTERNATIONAL REGISTRATION 1074161 DATED 2-9-2011, EXPIRES 2-9-2021.

NO CLAIM IS MADE TO THE EXCLUSIVE RIGHT TO USE "IASSET.COM", APART FROM THE MARK AS SHOWN.

THE COLOR(S) LIGHT BLUE AND DARK BLUE IS/ARE CLAIMED AS A FEATURE OF THE MARK.

THE MARK CONSISTS OF WORDING "IASSET.COM" WITH THE LETTER "I" IN LIGHT BLUE, THE WORDS "ASSET AND "COM" IN DARK BLUE, AND THE "DOT" BEING FORMED BY A DESIGN OF THE EARTH IN LIGHT AND DARK BLUE.

CLASS 9—ELECTRICAL AND SCIENTIFIC APPARATUS

FOR COMMUNICATION SOFTWARE FOR PRODUCT LIFECYCLE, ASSET, RENEWALS, ANNUITIES AND LICENSE MAINTENANCE AND MANAGEMENT; DOWNLOADABLE COMPUTER PROGRAMS AND RECORDED SOFTWARE DISTRIBUTED ONLINE, NAMELY, COMPUTER PROGRAMS AND RECORDED SOFTWARE FOR PRODUCT LIFECYCLE, ASSET, RENEWALS, ANNUITIES AND LICENSE MAINTENANCE AND MANAGEMENT; COMPUTER SOFTWARE FOR PRODUCT LIFECYCLE, ASSET, RENEWALS, ANNUITIES AND LICENSE MAINTENANCE AND MANAGEMENT; COMPUTER SOFTWARE FOR BUSINESS PURPOSES, NAMELY, FOR PRODUCT LIFECYCLE, ASSET, RENEWALS, ANNUITIES AND LICENSE MAINTENANCE AND MANAGEMENT; COMPUTER SOFTWARE PROGRAMS FOR PRODUCT LIFECYCLE, ASSET, RENEWALS, ANNUITIES AND LICENSE MAINTENANCE AND MANAGEMENT; DATA COMMUNICATIONS SOFTWARE FOR PRODUCT LIFECYCLE, ASSET, RENEWALS, ANNUITIES AND LICENSE MAINTENANCE AND MANAGEMENT; DATA PROCESSING SOFTWARE FOR, NAMELY, PRODUCT LIFECYCLE, ASSET, RENEWALS, ANNUITIES AND LICENSE MAINTENANCE AND MANAGEMENT; INTEGRATED SOFTWARE PACKAGES FOR PRODUCT LIFECYCLE, ASSET, RENEWALS, ANNUITIES AND LICENSE MAINTENANCE AND MANAGEMENT; NETWORK MANAGEMENT COMPUTER SOFTWARE (U.S. CLS. 21, 23, 26, 36 AND 38).

CLASS 35—ADVERTISING AND BUSINESS

FOR COMPUTERIZED DATABASE MANAGEMENT SERVICES AND DATA PROCESSING SERVICES FOR OTHERS NAMELY, COLLECTION AND SYSTEMIZATION OF INFORMATION IN COMPUTER DATABASES RELATED TO BUSINESS ASSETS VIA AN ONLINE/COMPUTER BASED ASSET REGISTER (U.S. CLS. 100, 101 AND 102).

CLASS 42—SCIENTIFIC AND COMPUTER SERVICES

FOR ADVISORY SERVICES RELATING TO COMPUTER SOFTWARE; COMPUTER SOFTWARE PROGRAMMING SERVICES; DESIGN AND DEVELOPMENT OF COMPUTER SOFTWARE FOR OTHERS; DESIGN OF COMPUTER SOFTWARE; DEVELOPMENT OF COMPUTER SOFTWARE; DEVELOPMENT OF COMPUTER SOFTWARE APPLICATION SOLUTIONS; DEVELOPMENT OF SOFTWARE; HOSTING OF SOFTWARE AS A SERVICE (SAAS) SERVICES, NAMELY HOSTING DATABASE SOFTWARE FOR PRODUCT LIFECYCLE, ASSET, RENEWALS, ANNUITIES AND LICENSE MAINTENANCE AND MANAGEMENT; ONLINE PROVISIONS OF NON-DOWNLOADABLE WEB-BASED SOFTWARE FOR PRODUCT LIFECYCLE, ASSET, RENEWALS, ANNUITIES AND LICENSE MAINTENANCE AND MANAGEMENT; SOFTWARE CREATION; SOFTWARE ENGINEERING; WRITING OF COMPUTER SOFTWARE (U.S. CLS. 100 AND 101).

DEBRA LEE, EXAMINING ATTORNEY

SN 79-096,293. UPM-KYMMENE CORPORATION, FI-00130 HELSINKI, FINLAND, FILED 3-29-2011.

UPM Mificel

THE MARK CONSISTS OF STANDARD CHARACTERS WITHOUT CLAIM TO ANY PARTICULAR FONT, STYLE, SIZE, OR COLOR.

PRIORITY DATE OF 3-9-2011 IS CLAIMED.

OWNER OF INTERNATIONAL REGISTRATION 1074205 DATED 3-29-2011, EXPIRES 3-29-2021.

OWNER OF U.S. REG. NOS. 3,223,380, 3,715,350 AND OTHERS.

THE WORD "MIFICEL" HAS NO MEANING IN A FOREIGN LANGUAGE.

CLASS 1—CHEMICALS

FOR CHEMICAL THICKENING AGENTS FOR INDUSTRIAL USE IN THE MANUFACTURE OF OIL AND GAS WELL DRILLING FLUIDS, COSMETICS, BEVERAGES, FOOD PRODUCTS AND FOOD SUPPLEMENTS; CHEMICALS FOR USE IN THE FIELD OF OIL EXPLORATION AND PRODUCTION, NAMELY, THICKENING AGENTS FOR USE IN THE OIL WELL AND GAS WELL INDUSTRY; CHEMICAL ADDITIVES FOR OIL WELL DRILLING FLUIDS, CHEMICALS FOR USE IN OIL DRILLING; SOIL CONDITIONERS, NAMELY, THICKENING AGENTS FOR USE IN AGRICULTURE, HORTICULTURE AND FORESTRY; CHEMICAL ADDITIVES FOR USE AS BINDING AGENTS IN FEED PELLETS; CELLULOSE FOR INDUSTRIAL PURPOSES; CONCRETE ADDITIVES, NAMELY, THICKENING AND BINDING AGENTS FOR MAKING CONCRETE (U.S. CLS. 1, 5, 6, 10, 26 AND 46).

CLASS 2—PAINTS

FOR THICKENING AGENTS FOR PAINTS AND LACQUERS (U.S. CLS. 6, 11 AND 16).

GILBERT SWIFT, EXAMINING ATTORNEY

SN 79-096,541. JULIUS BLUM GMBH, AUSTRIA, FILED 3-7-2011.

LEGRABOX

THE MARK CONSISTS OF STANDARD CHARACTERS WITHOUT CLAIM TO ANY PARTICULAR FONT, STYLE, SIZE, OR COLOR.

PRIORITY DATE OF 2-24-2011 IS CLAIMED.

OWNER OF INTERNATIONAL REGISTRATION 1074836 DATED 3-7-2011, EXPIRES 3-7-2021.

CLASS 6—METAL GOODS

FOR DRAWER COMPONENTS MADE OF METAL, NAMELY, COMMON METAL DRAWER PULLS, DRAWER SIDE WALLS, DRAWER REAR WALLS, DRAWER FRONT WALLS, DRAWER BOTTOMS, GALLERY RAILS, CONNECTORS FOR CONNECTING DRAWER WALLS, DRAWER RUNNERS (U.S. CLS. 2, 12, 13, 14, 23, 25 AND 50).

CLASS 20—FURNITURE AND ARTICLES NOT OTHERWISE CLASSIFIED

FOR DRAWERS; DRAWER COMPONENTS, NOT OF METAL, NAMELY, DRAWER PULLS OF PLASTIC OR WOOD, DRAWER SIDE WALLS, DRAWER REAR WALLS, DRAWER FRONT WALLS, DRAWER BOTTOMS, GALLERY RAILS, CONNECTORS FOR CONNECTING DRAWER WALLS (U.S. CLS. 2, 13, 22, 25, 32 AND 50).

TASNEEM HUSSAIN, EXAMINING ATTORNEY

SN 79-096,573. GARAGONON, GUILLAUME FRANCIS, PORTES-LÈS-VALENCE, FRANCE, AND BLANC, OLIVIER, SAINT-PÉRAY, FRANCE, FILED 12-13-2010.

LUCIDE

THE MARK CONSISTS OF STANDARD CHARACTERS WITHOUT CLAIM TO ANY PARTICULAR FONT, STYLE, SIZE, OR COLOR.

PRIORITY DATE OF 6-14-2010 IS CLAIMED.

OWNER OF INTERNATIONAL REGISTRATION 1074900 DATED 12-13-2010, EXPIRES 12-13-2020.

THE ENGLISH TRANSLATION OF "LUCIDE" IN THE MARK IS "LUCID".

CLASS 3—COSMETICS AND CLEANING PREPARATIONS

FOR PERFUMES, PERFUMERY, TOILET WATER, EAU DE PARFUM, ESSENTIAL OILS FOR PERSONAL USE, COSMETICS, MAKE-UP PREPARATIONS, HAIR AND BODY LOTIONS, SOAP, DENTIFRICES, DEODORANTS FOR PERSONAL USE, TISSUES IMPREGNATED WITH COSMETIC LOTIONS, SHOWER GELS, SHAMPOOS, BEAUTY CREAMS FOR USE ON THE BODY, SHAVING PREPARATIONS, SHAVING CREAMS, AFTER-SHAVE LOTIONS, AFTER-SHAVE BALMS, COSMETIC PREPARATIONS FOR BATHS, COSMETIC CREAMS, LOTIONS FOR COSMETIC PURPOSES, NON-MEDICATED TOILETRIES, BLEACHING PREPARATIONS AND OTHER SUBSTANCES FOR LAUNDRY USE, NAMELY, LAUNDRY SOAP AND POWDER, LAUNDRY BLEACH, LAUNDRY DETERGENT, LAUNDRY STARCH, LAUNDRY PRE-SOAK, FABRIC SOFTENER AND BLUING FOR LAUNDRY USE; PREPARATIONS FOR CLEANING, POLISHING AND DEGREASING FOR HOUSEHOLD USE; CLEANING PREPARATIONS, OILS FOR CLEANING PURPOSES, LEATHER PRESERVATIVES AS POLISHES, LEATHER BLEACHING PREPARATIONS, POLISHING CREAMS, CREAMS FOR LEATHER, SHOE CREAM, SHOE POLISH, SHOE WAX, SHOEMAKERS' WAX (U.S. CLS. 1, 4, 6, 50, 51 AND 52).

CLASS 6—METAL GOODS

FOR COMMON METALS AND THEIR ALLOYS; BUILDING MATERIALS OF METAL, NAMELY, SOFFITS, FASCIA, VENTS, TRIMS, FAÇADE, ARMORING WIRE, REINFORCEMENTS, STUDS, SHEETS, FRAMES, GUTTERS, SKIRTING, CLIPS, TRACKS AND SCREEDS; IRONMONGERY, NAMELY, SMALL ITEMS OF METAL HARDWARE, NAMELY, NUTS AND WASHERS, PULLERS, SPRINGS; METAL SAFES; GOODS OF COMMON METAL, NAMELY, FIGURINES, BOXES, BUCKLES, KEY RINGS, INGOTS, BASKETS, IDENTITY PLATES AND LOCKS; ORES OF METAL; METAL FASTENERS FOR BAGS AND POUCHES, METAL FASTENERS, NAMELY, METAL CLASPS FOR LEATHER OR IMITATION LEATHER GOODS, NAMELY, WALLETS, PURSES, CARD CASES, ATTACHE CASES, LEATHER KEY HOLDERS, HOLDERS FOR CHECKBOOKS, PASSPORT HOLDERS, CASES FOR PHOTOGRAPHS, AND CASES INTENDED TO CONTAIN TOILETRY ARTICLES SOLD EMPTY; BOXES OF COMMON METAL, BOX FASTENERS, NAMELY, METAL LOCKS; BOTTLE CAPS OF METAL, BOTTLE CLOSURES OF METAL, METAL KNOBS BEING HANDLES, METAL PADLOCKS, FERULES OF METAL FOR WALKING-STICKS AND UMBRELLAS, NAILS, METAL FASTENERS, NAMELY, NAILS, KNIFE HANDLES OF METAL, SIGNBOARDS OF METAL, FITTINGS OF METAL FOR FURNITURE, MONEY BOXES OF METAL, RIVETS OF METAL, METAL BELLS, HOOKS OF METAL FOR CLOTHES RAILS, DOOR HANDLES OF METAL (U.S. CLS. 2, 12, 13, 14, 23, 25 AND 50).

CLASS 9—ELECTRICAL AND SCIENTIFIC APPARATUS

FOR BLANK MAGNETIC DATA CARRIERS, BLANK RECORDING DISCS; CALCULATING MACHINES, SPECTACLE CASES, SUNGLASSES, SPORTS EYEWEAR, OPTICAL GLASSES, SPECTACLES, BINOCULARS, BINOCULAR CASES, TELESCOPES, PROTECTIVE HELMETS FOR SPORTS, RIDING CAPS FOR HORSEBACK RIDING; BLANK USB FLASH DRIVES, ELECTRONIC AGENDAS, HAND-HELD ELECTRONIC GAMES ADAPTED FOR USE WITH TELEVISION RECEIVERS ONLY, COMPUTER GAME PROGRAMS, COMPUTER MICE, COMPUTER MOUSE PADS, TEMPERATURE INDICATORS, RULERS, RANGE FINDERS, MEASURING RODS, DIRECTIONAL COMPASSES, MAGNIFYING GLASSES; DOG WHISTLES (U.S. CLS. 21, 23, 26, 36 AND 38).

CLASS 14—JEWELRY

FOR PRECIOUS METALS AND THEIR ALLOYS AND CHARMS MADE OF OR COATED WITH THESE MATERIALS, PRECIOUS STONES, JEWELRY, CHOKERS, BRACELETS, RINGS, EARRINGS, PENDANTS, BROOCHES, BADGES AS JEWELRY; CUFF LINKS, MEDALS, MEDALLIONS, TRINKETS, NAMELY, RINGS, TIE CLIPS, TIE PINS, CHAINS AS JEWELRY, BOXES OF PRECIOUS METAL, JEWELRY CASES, JEWEL AND WATCH CASES NOT OF PRECIOUS METAL; HOROLOGICAL AND CHRONOMETRIC INSTRUMENTS, WATCHES AND COMPONENT PARTS THEREOF; WATCHES, CHRONOMETERS, WRISTWATCHES, CLOCKS, SMALL CLOCKS, WATCH STRAPS, WATCH CLASPS, WATCH FACES; WATCH CASES, WATCH CHAINS, MOVEMENTS FOR CLOCKS AND WATCHES, CASES FOR CLOCK- AND WATCHMAKING, CASES FOR WATCHES, KEY RINGS TRINKETS OR FOBS OF PRECIOUS METAL; SCARF RINGS BEING JEWELRY (U.S. CLS. 2, 27, 28 AND 50).

CLASS 18—LEATHER GOODS

FOR LEATHER OR IMITATION LEATHER GOODS, NAMELY, SADDLERY ARTICLES, NAMELY, SADDLE TREES, BRIDLES AS HARNESSSES, BRIDOONS, BELTS AND LEATHER STRAPS AS SADDLERY, REINS, HORSESHOES, HORSE COLLARS, STIRRUPS, PARTS OF RUBBER FOR STIRRUPS, STIRRUP LEATHERS, HARNESS, HEAD-STALLS, HALTERS, FASTENINGS FOR SADDLES, LEATHER STRAPS, SHOULDER BELTS AS STRAPS OF LEATHER, KNEE-PADS FOR HORSES, BLINKERS AS RIDING TACK, HORSE BLANKETS, SADDLE CLOTHS FOR HORSES, RIDING SADDLE UNDERPADS, WHIPS, CAT O' NINE TAILS, RIDING CROPS, CONTAINERS FOR SADDLES, RIDING SADDLES, BITS FOR ANIMALS AS HARNESS, HARNESS FITTINGS; LEATHER STRAPS, BOXES OF LEATHER OR LEATHER BOARD, HAT BOXES OF LEATHER, HAT BOXES FOR TRAVEL NOT OF PAPER OR CARDBOARD BUT OF VULCANIZED FIBER, WALKING STICK, WALKING-STICK SEATS, SUITCASE HANDLES, COLLARS FOR ANIMALS, ANIMAL LEASHES, MUZZLES, BAGS FOR CARRYING ANIMALS, HARNESS FOR ANIMALS, ANIMAL SKINS, PELTS AND HIDES, LEATHER LEADS, LEATHER TWIST, NAMELY, LEATHER THREAD, LEATHER TRIMMINGS FOR FURNITURE, HUNTER'S GAME BAGS, LEATHER FOR FURNITURE MANUFACTURED INTO FURNITURE COVERINGS, MOLESKIN AS IMITATION LEATHER, SMALL BAGS AND BAGS MADE OF LEATHER FOR PACKAGING PURPOSES (U.S. CLS. 1, 2, 3, 22 AND 41).

CLASS 20—FURNITURE AND ARTICLES NOT OTHERWISE CLASSIFIED

FOR FURNITURE; FIGURINES AND BUSTS OF WOOD, CORK, REED, CANE, WICKER, HORN, BONE, IVORY, WHALEBONE, SHELL, AMBER, MOTHER-OF-PEARL, MEERSCHAUM, AND SUBSTITUTES FOR ALL THESE MATERIALS AND PLASTICS; FRAMES FOR PHOTOGRAPHS, PICTURE FRAMES, MOLDINGS FOR PICTURE FRAMES, CHESTS FOR TOYS, CHESTS AS FURNITURE, CUSHIONS, MOBILES AS DECORATIVE OBJECTS, DECORATIVE MOBILES PRODUCING SOUNDS, MATTRESSES, CUSHIONS AND BEDS FOR ANIMALS; WOODEN BOXES SOLD EMPTY FOR STORAGE OF PERSONAL ITEMS; PLASTIC CASES SOLD EMPTY CONTAINING A VIBRATING ALARM AS A REMINDER TO THE PATIENT TO TAKE MEDICATION; CORKS FOR BOTTLES; BOTTLE CAPS, NOT OF METAL; HIGH CHAIRS FOR BABIES, PLAYPENS FOR BABIES, MATS FOR INFANT PLAYPENS, CRADLES; COAT HANGERS; KNIFE HANDLES, NOT OF METAL; MIRRORS, HAND-HELD MIRRORS, SILVERED GLASS AS MIRRORS; FURNISHINGS, NAMELY, TABLETOPS, UMBRELLA STANDS, BOOK RESTS, MAGAZINE RACKS, HAT STANDS, CHAIRS, EASY CHAIRS, ARM-CHAIRS, SETTEES, DIVANS, SEATS, FOOTSTOOLS, SOFAS, POUFS, HEAD-RESTS, NAMELY, HEAD SUPPORTING PILLOWS, BEDS, CUPBOARDS; BINS, NOT OF METAL; BENCHES, SCREENS, DOORS FOR FURNITURE, WRITING DESKS, PLATE RACKS, GLASS DISPLAY CASES, BOOKCASE SHELVES AND SHELVING, COATSTANDS, BEDSTEADS OF WOOD, WOODEN FURNITURE PARTITIONS, SIDEBOARDS, DINNER WAGONS, INDEX CABINETS AS FURNITURE, TABLES, DRAUGHTMAN'S TABLES, WASHSTANDS, BUREAUX, NAMELY, WRITING DESKS, OFFICE FURNITURE, DESKS; WORKS OF ART OF WOOD, WAX, PLASTER OR PLASTIC; BUSTS, FIGURINES AND STATUES OF WOOD, WAX, PLASTER OR PLASTIC; BUSTS FOR TAILORS, NAMELY, MANNEQUINS; FRAMES FOR EMBROIDERY, KEYCABINETS FOR HANGING KEYS; TRAYS, NOT OF METAL; COAT HOOKS, NOT OF METAL; CLOTHES HOOKS, NOT OF METAL; DISPLAY BOARDS, SIGNBOARDS AND SIGNS OF WOOD OR OF PLASTIC MATERIALS; FANS FOR PERSONAL USE, NON-METALLIC BED; NON-METAL HANDLES FOR FURNITURE AND DOORS; COVERS FOR CLOTHING IN THE NATURE OF WARDROBE AND ARMOIRES; COVERS FOR CLOTHES, NAMELY, NON-METAL FABRIC STORAGE BIN ORGANIZERS; DISPLAY STANDS FOR NEWSPAPERS; MAIL BOXES NEITHER OF METAL NOR OF MASONRY; TAILORS' DUMMIES; BASKETS, NOT OF METAL, NAMELY, BASKETS FOR TRANSPORTING GOODS FOR COMMERCIAL PURPOSES; DOOR HANDLES, NOT OF METAL; DISPLAY STANDS; DESKS; RIVETS, NOT OF METAL; INDOOR TABLES FOR WINDOWS; WICKERWORK, NAMELY, TABLES AND DRAWER PULLS OF WICKER; BOTTLE RACKS (U.S. CLS. 2, 13, 22, 25, 32 AND 50).

CLASS 21—HOUSEWARES AND GLASS

FOR HOUSEHOLD OR KITCHEN CONTAINERS AND UTENSILS, NAMELY, SPATULAS; COMBS AND BATH SPONGES, COMB AND BRUSH CASES, HAIR BRUSHES, MATERIAL FOR BRUSH-MAKING; ARTICLES FOR CLEANING PURPOSES, NAMELY, CLEANING CLOTHS; UNWORKED OR SEMI-WORKED GLASS EXCEPT GLASS USED IN BUILDING; GLASSWARE FOR USE IN TABLE ART, NAMELY, DRINKING GLASSES, DECANTERS; GLASS TABLEWARE, NAMELY, GLASS BOWLS; PORCELAIN WARE FOR USE IN TABLE ART, NAMELY, BUSTS OF PORCELAIN; PORCELAIN TABLEWARE, NAMELY, PORCELAIN MUGS; EARTHENWARE FOR USE IN TABLE ART, NAMELY, BUSTS; ISOTHERMIC BAGS, NAMELY, INSULATED BAGS FOR BEVERAGES FOR DOMESTIC USE; ISOTHERMIC BAGS, NAMELY, INSULATED BAGS FOR BEVERAGES FOR DOMESTIC USE FOR FEEDING BOTTLES; TOILET BRUSHES, TOILET SPONGES, TOILETRY CASES SOLD EMPTY, TOILET UTENSILS, NAMELY, COSMETIC BRUSHES; FLOWER-POT COVERS, NOT OF PAPER; PLATES, BOWLS, EGG CUPS, FRUIT CUPS, POTS, DEMIJOHNS; BOXES FOR SWEETMEATS, NAMELY, PLASTIC CONTAINERS, NAMELY, CAKE BOXES FOR HOUSEHOLD USE; ICE PAILS, BUTTER COOLERS, SALAD BOWLS, SAUCERS, SOUP TUREENS, SUGAR BOWLS, TABLE CENTERPIECES, NAMELY, WORKS OF

ART MADE OF CHINA; DRINKING CUPS, COFFEE AND TEA SERVICES, NON-ELECTRIC COFFEE AND TEA MAKERS, DRINKING GLASSES, NAMELY, TUMBLERS, DISHES, DISH COVERS, CUPS, PORRINGERS AS SHALLOW BOWLS, CHOPSTICKS, BUTTER DISHES; HEATERS FOR FEEDING BOTTLES, NON-ELECTRIC; COOKIE JARS, SOAP BOXES, COFFEE AND TEA BOXES, METAL BOXES FOR DISPENSING PAPER TOWELS, GLASS BOXES, GLASS STOPPERS, CORK-SCREWS, CANDLE HOLDERS, CANDLESTICKS, NON-ELECTRIC CANDELABRAS, BOTTLES SOLD EMPTY, BOTTLE OPENERS; DOOR KNOBS MADE OF PORCELAIN; PERFUME BURNERS; COASTERS, NOT OF PAPER AND OTHER THAN TABLE LINEN; MENU CARD HOLDERS, BREAD BASKETS FOR DOMESTIC USE, KNIFE RESTS FOR THE TABLE, CRYSTAL AS BEVERAGE GLASSWARE; MIXING SPOONS; TOOTH-PICK HOLDERS, TRIVETS; SIGNBOARDS OF PORCELAIN OR GLASS; SPICE RACKS; SPONGE HOLDERS; WORKS OF ART, OF PORCELAIN, TERRA-COTTA OR GLASS; BUSTS, FIGURINES, STATUES AND STATUETTES OF PORCELAIN, TERRA-COTTA OR GLASS; FLOWER POTS, HOLDERS FOR FLOWERS; GARDENING GLOVES; NON-ELECTRIC PORTABLE COOLERS; HURRICANE LAMPS; VEGETABLE DISHES; LIQUEUR GLASS SETS, NAMELY, DECANTERS; MOSAICS OF GLASS, NOT FOR BUILDING, FITTED PICNIC BASKETS INCLUDING DISHES; SMALL BOTTLES SOLD EMPTY; PERFUME SPRAYERS, PERFUME VAPORIZERS SOLD EMPTY, TART SCOOPS, TRAYS FOR DOMESTIC PURPOSES, HAND-OPERATED PEPPER MILLS, PEPPER POTS, SALT CELLARS, DISHES FOR SOAP, TOWEL CLOSETS, TOWEL HOLDERS, NAMELY, RINGS AND BARS; POTTERY, NAMELY, CLAY POTS; POTS; POT LIDS; GLASS POWDER BOXES, NAPKIN RINGS; VASES; COMBS FOR ANIMALS, HORSE BRUSHES, MANGERS FOR ANIMALS, CURRY-COMBS, SHOE HORNS, SHOE BRUSHES, SHOE TREES; PIGGY BANKS, NOT OF METAL; HEAT INSULATED CONTAINERS FOR BEVERAGES; INSULATING FLASKS; REFRIGERATING BOTTLES SOLD EMPTY; MANUAL MIXERS IN THE NATURE OF COCKTAIL SHAKERS; GLASS CARAFES (U.S. CLS. 2, 13, 23, 29, 30, 33, 40 AND 50).

CLASS 25—CLOTHING

FOR CLOTHING FOR MEN, WOMEN AND CHILDREN, NAMELY, PAJAMAS, DRESSING GOWNS, NIGHTGOWNS, LAYETTES, PANTS, BATHING TRUNKS, BATHING SUITS, OVERALLS, BOAS, TEDDIES, PULLOVERS, SWEATERS, WAISTCOATS, KNIT TOPS, SHIRTS, SHIRT YOKES, SHIRT FRONTS, CHEMISETTES, COLLARS; READY-MADE CLOTHING, NAMELY, UNDERWEAR, BREECHES FOR WEAR, UNDERPANTS, SARIS, TEE-SHIRTS, TROUSERS, JACKETS, SUITS, UNIFORMS, COATS, GABARDINE SUITS; RAINCOATS, OVERCOATS, PARKAS, SKIRTS, DRESSES, BOOTS, HALF-BOOTS, ESPARTO SHOES OR SANDALS, BEACH SHOES, CLOGS, SPORTS FOOTWEAR, BOOT LINERS, NAMELY, INSOLES, FOOTWEAR, SLIPPERS, BATH SANDALS, BOOT UPPERS, IRON FITTINGS FOR FOOTWEAR; FASHIONABLE CLOTHING ACCESSORIES FOR MEN, WOMEN AND CHILDREN, NAMELY, HATS, CAPS, BONNETS, TOP HATS, GLOVES, MITTENS, FINGERLESS GLOVES, NECKTIES, BELTS, MONEY BELTS, SCARVES, ASCOTS, POCKET SQUARES, SASHES FOR WEAR, SHAWLS, STOCKINGS, SOCKS, TIGHTS, SUSPENDERS, BIBS NOT OF PAPER, HEADBANDS, LEATHER AND IMITATION LEATHER CLOTHING, NAMELY, JACKETS; FUR STOLS, FUR CLOAKS, PAREOS, APRONS (U.S. CLS. 22 AND 39).

CLASS 26—FANCY GOODS

FOR METAL CLASPS FOR BELTS (U.S. CLS. 37, 39, 40, 42 AND 50).

CLASS 35—ADVERTISING AND BUSINESS

FOR BUSINESS MANAGEMENT; BUSINESS ADMINISTRATION; OFFICE FUNCTIONS; ADVERTISING ESPECIALLY ADVERTISING BY ELECTRONIC MEANS ON GLOBAL COMPUTER NETWORKS SUCH AS THE INTERNET; ADVERTISING BY MAIL ORDER; PUBLICITY MATERIAL RENTAL; LEASING OF ADVERTISING SPACE; DISSEMINATION OF ADVERTISING MATTER; ADVERTISING MAILING ESPECIALLY ON GLOBAL COMPUTER NETWORKS SUCH AS THE INTERNET; COPYWRITING AND PUBLISHING ADVERTISING TEXTS; UPDATING OF ADVERTISING DOCUMENTS; PAGE LAYOUT SERVICES FOR ADVERTISING; OUTDOOR ADVERTISING, NAMELY, PRESENTATION AND DEMONSTRATION OF GOODS ON ALL MEANS OF COMMUNICATION; SALES PROMOTION FOR OTHERS; COMMERCIAL INFORMATION AND ADVICE TO CONSUMERS; SHOP-WINDOW DRESSING INCLUDING ON INTERNET SITES; BUSINESS MANAGEMENT OF PERFORMING ARTISTS; DOCUMENT REPRODUCTION; DISTRIBUTION OF SAMPLES; ORGANIZATION OF EXHIBITIONS FOR COMMERCIAL OR ADVERTISING PURPOSES; COMPUTERIZED FILE MANAGEMENT; IMPORT-EXPORT AGENCIES; MODELING FOR ADVERTISING OR SALES PROMOTION; PUBLIC RELATIONS; SPONSORSHIP SEARCH; NEWS CLIPPING SERVICES; BUSINESS EVALUATIONS; BUSINESS MANAGEMENT AND ORGANIZATION CONSULTANCY; INFORMATION OR ENQUIRIES ON BUSINESS AND MARKETING; ADMINISTRATIVE PROCESSING OF PURCHASE ORDERS; COMMERCIAL OR INDUSTRIAL MANAGEMENT ASSISTANCE, NAMELY, AID AND ASSISTANCE IN THE OPERATION, ORGANIZATION OR MANAGEMENT OF A COMMERCIAL UNDERTAKING; BUSINESS APPRAISALS; COMPILATION OF INFORMATION INTO COMPUTER DATABASES; BUSINESS INFORMATION; MARKETING RESEARCH; BUSINESS RESEARCH; MESSAGE TRANSCRIPTION; RETAIL STORE SERVICES FEATURING PERFUMES, PERFUMERY, TOILET WATER, EAU DE PARFUM, ESSENTIAL OILS FOR PERSONAL USE, COSMETICS, MAKE-UP PREPARATIONS, HAIR AND BODY LOTIONS, SOAP, DENTIFRICES, DEODORANTS FOR PERSONAL USE, TISSUES IMPREGNATED WITH COSMETIC LOTIONS, SHOWER GELS, SHAMPOOS, BEAUTY CREAMS FOR USE ON THE BODY, SHAVING PREPARATIONS, SHAVING CREAMS, AFTER-SHAVE LOTIONS, AFTER-SHAVE BALMS, COSMETIC PREPARATIONS FOR BATHS, COSMETIC CREAMS, LOTIONS FOR COSMETIC PURPOSES, TOILETRIES, BLEACHING PREPARATIONS AND OTHER SUBSTANCES FOR LAUNDRY USE, PREPARATIONS FOR CLEANING, POLISHING AND DEGREASING, CLEANING PRODUCTS, OILS FOR CLEANING PURPOSES, LEATHER PRESERVATIVES, LEATHER BLEACHING PREPARATIONS, POLISHING CREAMS, CREAMS FOR LEATHER, SHOE CREAM, SHOE POLISH, SHOE WAX, SHOEMAKERS' WAX, COMMON METALS AND THEIR ALLOYS, METAL BUILDING MATERIALS, IRONMONGERY AND SMALL ITEMS OF METAL HARDWARE, SAFES, ORES, METAL FASTENERS FOR BAGS AND POUCHES, METAL FASTENERS FOR LEATHER OR IMITATION LEATHER GOODS, NAMELY, WALLETS, PURSES, CARD CASES, ATTACHE CASES, LEATHER KEY HOLDERS, CHECK-BOOK HOLDERS, PASSPORT HOLDERS, CASES FOR PHOTOGRAPHS, CASES INTENDED TO CONTAIN TOILETRY ARTICLES SOLD EMPTY, BOXES OF COMMON METAL, BOX FASTENERS OF METAL, BOTTLE CAPS OF METAL, BOTTLE CLOSURES OF METAL, METAL KNOBS, PADLOCKS, FERRULES OF METAL FOR WALKING-STICKS AND UMBRELLAS, NAILS, KNIFE HANDLES OF METAL, SIGNBOARDS OF METAL, FITTINGS OF METAL FOR FURNITURE, MONEY BOXES OF METAL, RIVETS OF METAL, BELLS, HOOKS OF METAL FOR CLOTHES RAILS, DOOR HANDLES OF METAL, HAND-OPERATED HAND TOOLS AND IMPLEMENTS, NON-ELECTRIC CUTLERY, FORKS AND SPOONS, SIDE ARMS, OTHER THAN FIREARMS, RAZORS, SILVER PLATED KNIVES, FORKS AND SPOONS, POCKET KNIVES, PEN-KNIVES, HUNTING KNIVES, SHOE LASTS AS SHOEMAKERS' TOOLS, SCISSORS, HAND-OPERATED GARDEN TOOLS, SECATEURS, FLOWER CUTTERS, MANICURE AND PEDICURE SETS, SHAVING CASES, TWEEZERS, SUGAR TONGS, MAGNETIC RECORDING MEDIA, SOUND RECORDING DISKS, CALCULATING MACHINES, DATA PROCESSING EQUIPMENT AND COMPUTERS, SPECTACLE CASES, SUNGLASSES,

SPORTS EYEWEAR, OPTICAL GOODS, SPECTACLES, BINOCULARS, BINOCULAR CASES, SPYGLASSES, PROTECTIVE HELMETS FOR SPORTS, RIDING CAPS FOR HORSE-RIDING, USB FLASH DRIVES, ELECTRONIC AGENDAS, ELECTRONIC GAMES, COMPUTER GAME PROGRAMS, COMPUTER MICE, COMPUTER MOUSE PADS, TEMPERATURE INDICATORS, RULES AS MEASURING INSTRUMENTS, RULERS, DIRECTIONAL COMPASSES, LOUPES, DOG WHISTLES, MOBILE TELEPHONES, RANGE FINDERS, MEASURING RODS, LAMPS, ELECTRIC LAMPS, CHANDELIERS, FLOOR LAMPS, POCKET LAMPS, LIGHTS FOR CYCLES AND VEHICLES, LAMP SHADES, NIGHTLIGHTS, CEILING LIGHTS, FAUCETS, VEHICLES, APPARATUS FOR LOCOMOTION BY LAND, AIR OR WATER, BICYCLES, CYCLES, AUTOMOBILES, BOATS, YACHTS, BABY CARRIAGES, PRECIOUS METALS AND THEIR ALLOYS, PRECIOUS STONES, JEWELRY, CHOKERS AS NECKLACES, BRACELETS, RINGS, EARRINGS, PENDANTS, BROOCHES, BADGES AS JEWELRY, CUFF LINKS, MEDALS, MEDALLIONS, TRINKETS, TIE CLIPS, TIE PINS, CHAINS AS JEWELRY, BOXES OF PRECIOUS METAL, JEWELRY CASES, WATCH CASES NOT OF PRECIOUS METAL, JEWEL AND WATCH CASES NOT OF PRECIOUS METAL, HOROLOGICAL AND CHRONOMETRIC INSTRUMENTS, WATCHES AND COMPONENT PARTS THEREOF, CHRONOGRAPHS, CHRONOMETERS, WRISTWATCHES, CLOCKS, WALL CLOCKS, PENDULETTES, WATCH BANDS, WATCH CLASPS, WATCH DIALS, WATCH CASES, WATCH CHAINS, MOVEMENTS FOR CLOCKS AND WATCHES, CASES FOR CLOCK- AND WATCH-MAKING, PRESENTATION CASES, WATCH PRESENTATION CASES, KEY RINGS, MUSICAL INSTRUMENTS, MUSICAL BOXES, PAPER, CARDBOARD AND GOODS MADE FROM THESE MATERIALS, NAMELY, BOXES, BAGS, SMALL BAGS, ENVELOPES AND POUCHES FOR PACKAGING PURPOSES, WRAPPING PAPER, SCRAPBOOKS, PRINTED MATTER, TYPE FOR PRINTING PURPOSES, PRINTER'S TYPE AS NUMERALS AND LETTERS, PRINTING BLOCKS, ADDRESS STAMPS, BOOKBINDING ARTICLES, STATIONERY ARTICLES, DOCUMENT FILES AS STATIONERY, DIARIES, DIARY COVERS, ALMANACS, TEAR-OFF CALENDARS, PADS AS STATIONERY, PAPER SHEETS AS STATIONERY, DRAWING PADS, WRITING OR DRAWING BOOKS, CALENDARS, NOTE BOOKS, INDEXES, COVERS AS STATIONERY, BINDERS AS OFFICE SUPPLIES, PENCILS, PENCIL LEADS, PENCIL HOLDERS, PENCIL LEAD HOLDERS, FELT PENS, PENS, PENHOLDERS, DRAWING PENS, NIBS, BOXES FOR PENS, PASTELS AS CRAYONS, PENCIL SETS, DRAWING SETS, PENCIL HOLDERS, ANNOUNCEMENT CARDS, INDEX CARDS, WRITING PAPER, ENVELOPES, ADHESIVES GLUES FOR STATIONERY OR HOUSEHOLD PURPOSES, ARTISTS' MATERIALS, PAINTBRUSHES, SMALL BRUSHES, PAINTERS' EASELS, CANVAS FOR PAINTING, PALLETES FOR PAINTERS, PAINT BOXES AS ARTICLES FOR USE IN SCHOOL, GRAPHIC PRINTS, DRAWING INSTRUMENTS, DRAWING MATERIALS, PAPER CLIPS, TYPEWRITERS AND OFFICE REQUISITES EXCEPT FURNITURE, INSTRUCTIONAL OR TEACHING MATERIAL EXCEPT APPARATUS, PLASTIC MATERIALS FOR PACKAGING, CHECK-HOLDER CASES, EMBROIDERY DESIGNS, PRINTED MATTER, GRAPHIC REPRESENTATIONS AND REPRODUCTIONS, PHOTOGRAPHS, PHOTOGRAPH STANDS, PHOTO-ENGRAVINGS, ENGRAVINGS, PICTURES, PORTRAITS, POSTERS, BOOKS, BOOKLETS, MANUALS, CATALOGS, PAMPHLETS, PERIODICALS, PUBLICATIONS, PRINTED MATTER, PROSPECTUSES, NEWSPAPERS, REVIEWS, MAPS, MUSICAL VISITING CARDS, POSTCARDS, MONEY CLIPS, ADVERTISEMENT BOARDS OF PAPER OR CARDBOARD, SEALING STAMPS, SEALS, STAMPS FOR SEALS, STAMP CASES, SIGNBOARDS OF PAPER OR CARDBOARD, PAPER CUTTERS AS OFFICE REQUISITES, TABLE LINEN OF PAPER, TABLECLOTHS OF PAPER, TABLE NAPKINS OF PAPER, PLACE MATS OF PAPER, TABLECLOTHS OF PAPER, COASTERS OF PAPER, TABLEMATS OF PAPER, BIBS OF PAPER, HANDKERCHIEFS OF PAPER, FLOWER-POT COVERS OF PAPER, BOOKMARKERS, BOOKENDS, BOOKMARK, WRITING PADS, CARDBOARD HATBOXES, DUST JACKETS, LETTER TRAYS, ENGRAVINGS, LITHOGRAPHS, LITHOGRAPHIC WORKS OF ART, ATLASES, TICKETS, CARDBOARD ARTICLES, JACKETS FOR PAPERS, CHROMOS, PATTERNS FOR MAKING CLOTHES, PAPER FLAGS, PAPER PEN-

NANTS, SHIELDS AS PAPER SEALS, WRITING MATERIALS, WRITING INSTRUMENTS, HANDWRITING SPECIMENS FOR COPYING, INKSTANDS, SIGNBOARDS OF PAPER OR CARDBOARD, NON-TEXTILE LABELS, PAPER BOWS, PAPERWEIGHTS, ENGRAVING PLATES, DRAWING BOARDS, PLATES FOR ENGRAVINGS, BLUEPRINTS, STENCILS, DRAWING RULERS, PAINTING BOOKS, RUBBER ERASERS, BIRTHDAY BOOKS, STICKERS AS STATIONERY ITEMS, TIDIES, LEATHER OR IMITATION LEATHER GOODS EXCLUDING CASES ADAPTED TO THE PRODUCTS FOR WHICH THEY ARE INTENDED, NAMELY, HANDBAGS, TRAVELING BAGS, RUCKSACKS, SCHOOL BAGS AND SATCHELS, BEACH BAGS, SHOPPING BAGS, GARMENT BAGS FOR TRAVEL, SPORTS BAGS, DIAPER BAGS, PLAID BAGS, RETICULES, WHEELED BAGS, SLING BAGS FOR CARRYING INFANTS, WALLET, CARD CASES, ATTACHE CASES, KEY CASES, TIDIES MADE OF LEATHER, TRUNKS AND SUITCASES, TRAVELING TRUNKS, SETS AND CASES INTENDED TO CONTAIN TOILETRY ARTICLES SOLD EMPTY, POUCHES, SADDLERY ARTICLES, SADDLE TREES, BRIDLES, BRIDDOONS, BELTS AND LEATHER STRAPS, REINS, HORSESHOES, HORSE COLLARS, STIRRUPS, PARTS OF RUBBER FOR STIRRUPS, STIRRUP LEATHERS, HARNESS, REINS, HEAD-STALLS, HALTERS, FASTENINGS FOR SADDLES, LEATHER STRAPS, SHOULDER BELTS OF LEATHER, KNEE-PADS FOR HORSES, EYESHADES AS RIDING TACK, HORSE BLANKETS, COVERS FOR HORSE-SADDLES, RIDING SADDLE UNDERPADS, WHIPS, CAT O' NINE TAILS, RIDING CROPS, BOXES FOR SADDLES, RIDING SADDLES, BITS FOR ANIMALS, HARNESS FITTINGS, STRAPS, BOXES OF LEATHER OR LEATHER BOARD, HAT BOXES OF LEATHER, BOXES OF VULCANIZED FIBER, SUN UMBRELLAS, UMBRELLAS, PARASOLS, UMBRELLA RINGS, UMBRELLA COVERS, UMBRELLA STICKS, WALKING STICK AND UMBRELLA HANDLES, WALKING-STICK SEATS, SUITCASE HANDLES, COLLARS FOR ANIMALS, ANIMAL LEASHES, MUZZLES, COATS FOR ANIMALS, BAGS FOR ANIMALS, HARNESS FOR ANIMALS, ANIMAL SKINS, PELTS AND HIDES, BAGS FOR CAMPERS, LEATHER LEADS, LEATHER TRIMMINGS FOR FURNITURE, GAME BAGS, FURNITURE COVERINGS OF LEATHER, MOLESKIN AS IMITATION LEATHER, SMALL BAGS AND BAGS AS ENVELOPES AND POUCHES MADE OF LEATHER FOR PACKAGING PURPOSES, TOILETRY SETS AND TRAVELING SETS MADE OF TEXTILE MATERIALS, PLAID BAGS MADE OF TEXTILE MATERIALS, DIAPER BAGS MADE OF TEXTILE MATERIALS, FURNITURE, FRAMES FOR PHOTOGRAPHS, PICTURE FRAMES, MOLDINGS FOR PICTURE FRAMES, CHESTS FOR TOYS, BINS, NOT OF METAL, CUSHIONS, MOBILES AS DECORATIVE OBJECTS, DECORATIVE MOBILES PRODUCING SOUNDS, MATTRESSES, CUSHIONS AND BEDS FOR ANIMALS, WOODEN OR PLASTIC CASES AND BOXES, CORKS FOR BOTTLES, NON-METAL BOTTLE CAPS, HIGH CHAIRS FOR BABIES, PLAYPENS FOR BABIES, MATS FOR INFANT PLAYPENS, CRADLES, COAT HANGERS, HANDLES OF KNIVES, NON-METALLIC, MIRRORS, HAND-HELD MIRRORS, SILVERED GLASS, FURNISHINGS, TABLETOPS, UMBRELLA STANDS, BOOK RESTS, MAGAZINE RACKS, HAT STANDS, CHAIRS, EASY CHAIRS, ARMCHAIRS, SETTEES, DIVANS, SEATS, FOOTSTOOLS, SOFAS, POUFS, HEAD-RESTS, BEDS, CUPBOARDS, BINS, NOT OF METAL, BENCHES, SCREENS, DOORS FOR FURNITURE, WRITING DESKS, PLATE RACKS, GLASS DISPLAY CASES, BOOKCASE SHELVES AND SHELVING, COATSTANDS, BEDSTEADS OF WOOD, WOODEN FURNITURE PARTITIONS, SIDEBOARDS, DINNER WAGONS, INDEX CABINETS, TABLES, DRAUGHTMAN'S TABLES, WASHSTANDS, OFFICE FURNITURE, DESKS, WORKS OF ART OF WOOD, WAX, PLASTER OR PLASTIC, BUSTS, FIGURINES AND STATUES OF WOOD, WAX, PLASTER OR PLASTIC, BUSTS FOR TAILORS, FRAMES FOR EMBROIDERY, KEYBOARDS FOR HANGING KEYS, NON-METAL TRAYS, NON-METAL HOOKS FOR CLOTHES RAILS, NON-METAL CLOTHES HOOKS, DISPLAY BOARDS, SIGNBOARDS AND SIGNS OF WOOD OR OF PLASTIC MATERIALS, FANS FOR PERSONAL USE, NON-METALLIC BED, FURNITURE AND DOOR FITTINGS, COVERS FOR CLOTHING, NAMELY, A WARDROBE, COVERS FOR CLOTHES FOR STORAGE, DISPLAY STANDS FOR NEWSPAPERS, MAIL BOXES NEITHER OF METAL NOR OF MASONRY, TAILORS' DUMMIES, NON-METAL BASKETS,

NON-METAL DOOR HANDLES, DISPLAY STANDS, DESKS, NON-METAL RIVETS, INDOOR BLINDS FOR WINDOWS, BOTTLE RACKS, HOUSEHOLD OR KITCHEN UTENSILS AND CONTAINERS, COMBS AND SPONGES, COMB AND BRUSH CASES, BRUSHES EXCEPT PAINTBRUSHES, MATERIAL FOR BRUSH-MAKING, ARTICLES FOR CLEANING PURPOSES, UNWORKED OR SEMI-WORKED GLASS EXCEPT GLASS USED IN BUILDING, GLASSWARE FOR USE IN TABLE ART, NAMELY, DRINKING GLASSES, DECANTERS, GLASS TABLEWARE, PORCELAIN WARE FOR USE IN TABLE ART, TABLEWARE MADE OF PORCELAIN, EARTHENWARE FOR USE IN TABLE ART, ISOTHERMIC BAGS, ISOTHERMIC BAGS FOR FEEDING BOTTLES, TOILET BRUSHES, TOILET SPONGES, TOILET CASES, HOLDERS FOR FLOWERS, GARDENING GLOVES, NON-ELECTRIC PORTABLE COOLERS, HURRICANE LAMPS, TUMBLERS, VEGETABLE DISHES, LIQUEUR GLASS SETS, MOSAICS OF GLASS, NOT FOR BUILDING, FITTED PICNIC BASKETS INCLUDING DISHES, SMALL BOTTLES, PERFUME SPRAYERS, PERFUME VAPORIZERS, TART SCOOPS, TRAYS FOR DOMESTIC PURPOSES, HAND-OPERATED PEPPER MILLS, PEPPER POTS, SALT CELLARS, DISHES FOR SOAP, TOWEL HOLDERS, TOWEL HOLDERS AS RINGS AND BARS, POTTERY, POTS, POT LIDS, POWDER CASES, NAPKIN RINGS, VASES, COMBS FOR ANIMALS, HORSE BRUSHES, FEEDING TROUGHS FOR ANIMALS, CURRYCOMBS, SHOE-HORNS, SHOE BRUSHES, SHOE-TREES, NON-METAL PIGGY BANKS, HEAT INSULATED CONTAINERS FOR BEVERAGES, INSULATING FLASKS, REFRIGERATING BOTTLES, MANUAL MIXERS AS COCKTAIL SHAKERS, GLASSES AS RECEPTACLES, ROPES, STRINGS, NETS, TENTS, TARPAULINS SAILS, SACKS, RAW FIBROUS TEXTILE MATERIALS, FABRIC BAGS FOR PACKING, PACKAGING BAGS MADE OF TEXTILE MATERIALS, PLASTIC FIBERS FOR TEXTILE USE, TEXTILE FIBERS, SILK CLOTHS, WOVEN OR KNITTED FABRICS, NON-WOVEN FABRICS, TEXTILE MATERIAL FOR CLOTHING PURPOSES, BED AND TABLE COVERS, PLAID BLANKETS, CURTAINS OF TEXTILE OR PLASTIC, BLINDS, HOUSEHOLD LINEN, TABLE RUNNERS, COVERS FOR CUSHIONS, BED COVERS, BED LINEN, SHEETS, BATH LINEN EXCEPT CLOTHING, BATH SHEETS, FACE TOWELS, WASHING MITTS, GUEST TOWELS, TABLE LINEN NOT OF PAPER, TABLE NAPKINS OF TEXTILE, TABLEMATS NOT OF PAPER, HANDKERCHIEFS OF TEXTILE, LABELS OF CLOTH, SLEEPING BAGS AS SHEETING, CONTAINERS MADE OF TEXTILE MATERIALS, TIDIES MADE OF TEXTILE MATERIALS, UPHOLSTERY MATERIALS, FABRIC WITH MOTIFS DESIGNED FOR EMBROIDERY, COASTERS AS TABLE LINEN, FABRIC FOR BOOTS AND SHOES, TRAVELING RUGS, BED COVERS, LININGS AS TEXTILE, FLAGS NOT OF PAPER, DIAPERED LINEN, LINGERIE FABRIC, BED CLOTHES LINEN, UPHOLSTERY FABRICS, FURNITURE FABRICS, WALL HANGINGS OF TEXTILE, TABLECLOTHS NOT OF PAPER, TABLEMATS NOT OF PAPER, FABRICS FOR TEXTILE USE, SOFA THROWS, CLOTHING FOR MEN, WOMEN AND CHILDREN, PAJAMAS, HOUSECOATS, NIGHTSHIRTS, LAYETTES, DRESSING GOWNS, DRAWERS, BATHING TRUNKS, BATHING SUITS, SWIMSUITS, BLOUSES, BOAS, BODYSUITS, PULL-OVERS, SWEATERS, VESTS, KNITWEAR, SHIRTS, SHIRT YOKES, SHIRT FRONTS, CHEMISETTES, COLLARS, READY-MADE CLOTHING, UNDERCLOTHING, BRIEFS AND PANTS, PANTIES AND UNDERPANTS, UNDERWEAR, SARIS, TEE-SHIRTS TROUSERS, JACKETS, SUITS, UNIFORMS, COATS, GABARDINES, RAINCOATS, OVERCOATS, PARKAS, SKIRTS, DRESSES, BOOTS, HALF-BOOTS, ESPARTO SHOES OR SANDALS, BEACH SHOES, CLOGS, SPORTS FOOTWEAR, BOOT LINERS, FOOTWEAR, SLIPPERS, BATH SANDALS, BOOT UPPERS, IRON FITTINGS FOR FOOTWEAR, FASHIONABLE CLOTHING ACCESSORIES FOR MEN, WOMEN AND CHILDREN, NAMELY, HATS, CAPS, BONNETS, TOP HATS, GLOVES, MITTENS, FINGERLESS GLOVES, NECKTIES, BELTS, MONEY BELTS, SCARVES, ASCOTS, POCKET SQUARES, SASHES FOR WEAR, SHAWLS, STOCKINGS, SOCKS, TIGHTS, SUSPENDERS, BIBS, NOT OF PAPER, HEADBANDS, LEATHER AND IMITATION LEATHER CLOTHING, FUR STOLEES, FURS, SCARF RINGS, PAREOS, APRONS, LACE AND EMBROIDERY, RIBBONS AND BRAID, BUTTONS, SEQUINS, HOOKS AND EYES, PINS AND NEEDLES, ARTIFICIAL FLOWERS, SHOE FASTENERS, FASTENINGS FOR CLOTHING, FASTENINGS FOR

CLOTHES, SEWING BOXES, BUCKLES, SHOE BUCKLES, SNAP FASTENERS, FASTENINGS FOR SUSPENDERS, BROOCHES, BELT CLASPS, HAT ORNAMENTS, NOT OF PRECIOUS METAL, SHOE HOOKS, EYELETS FOR CLOTHING AND SHOES, SHOE ORNAMENTS NOT OF PRECIOUS METAL, HAIR ORNAMENTS, HAIR PINS, HAIR GRIPS, ZIP FASTENERS, FASTENINGS FOR CLOTHING, SLIDE LOCKS FOR BAGS, BADGES FOR WEAR, NOT OF PRECIOUS METAL, CARPETS, RUGS, MATS AND MATTING, LINOLEUM AND OTHER MATERIALS FOR COVERING EXISTING FLOORS, NON-TEXTILE WALL HANGINGS, BATH MATS, CARPETS AND RUGS, PAPER FOR WALL COVERINGS, WALLPAPER, CARPET UNDERLAY, GAMES, TOYS, GYMNASIAC AND SPORTING ARTICLES, DECORATIONS FOR CHRISTMAS TREES, PLAYING CARDS, CASES AND BOXES FOR PLAYING CARDS, MATS FOR GAMES, BOARD GAMES, COUNTERS FOR GAMES, TUMBLERS FOR DICE, DICE, ROCKING HORSES, GOLF GLOVES, RATTLES, PLUSH TOYS, TEDDY BEARS, PUZZLES, PARLOR GAMES, GAME BALLS, PLAY BALLS, MUSICAL MOBILES, PLAYING CARDS, BUILDING GAMES, CHECKERS, GOLF WITH OR WITHOUT ROLLERS, GOLF CLUBS, COVERS FOR DOLLS, DOLLS' CLOTHES, DOLLS' HOUSES, MARIONETTES, TOY MOBILES, TOY VEHICLES, ACTIVITY MATS, TOBACCO, SMOKERS' ARTICLES, MATCHES, MATCH BOXES, CIGAR BOXES AND CASES, CIGARETTE BOXES AND CASES, LIGHTERS FOR SMOKERS, ASHTRAYS FOR SMOKERS, CIGAR AND CIGARETTE CASES, CIGAR CUTTERS, TOBACCO JARS, SNUFF BOXES, NOT OF PRECIOUS METAL (U.S. CLS. 100, 101 AND 102).

TASNEEM HUSSAIN, EXAMINING ATTORNEY

SN 79-096,718. AKER MH AS, NORWAY, FILED 2-23-2011.

MyDrilling

THE MARK CONSISTS OF STANDARD CHARACTERS WITHOUT CLAIM TO ANY PARTICULAR FONT, STYLE, SIZE, OR COLOR.

PRIORITY DATE OF 8-27-2010 IS CLAIMED.
OWNER OF INTERNATIONAL REGISTRATION 1075253 DATED 2-23-2011, EXPIRES 2-23-2021.

CLASS 9—ELECTRICAL AND SCIENTIFIC APPARATUS

FOR APPARATUS AND INSTRUMENTS FOR CONDUCTING, SWITCHING, TRANSFORMING, ACCUMULATING, REGULATING OR CONTROLLING ELECTRICITY; APPARATUS FOR RECORDING, TRANSMISSION OR REPRODUCTION OF SOUND OR IMAGES; BLANK MAGNETIC DATA CARRIERS AND RECORDING DISCS; DATA PROCESSING EQUIPMENT AND COMPUTERS; COMPUTER SOFTWARE, DATABASES RECORDED ON COMPUTER MEDIA, SOFTWARE APPLICATIONS AND COMPUTER HARDWARE USED FOR SURVEILLANCE AND CONTROL OF ALL ACTIVITIES ON AN OIL RIG AND INDUSTRIAL PLANT; COMPUTER SOFTWARE DEVELOPMENT TOOLS FOR PROFESSIONAL NETWORKING, BUILDING PROFESSIONAL NETWORKING APPLICATIONS, AND FOR ALLOWING DATA RETRIEVAL, UPLOAD, ACCESS AND MANAGEMENT; COMPUTER SOFTWARE TO ENABLE UPLOADING, POSTING, SHOWING, DISPLAYING, TAGGING, BLOGGING, SHARING OR OTHERWISE PROVIDING ELECTRONIC MEDIA OR INFORMATION OVER THE INTERNET OR OTHER COMMUNICATIONS NETWORKS (U.S. CLS. 21, 23, 26, 36 AND 38).

CLASS 35—ADVERTISING AND BUSINESS

FOR ADVERTISING; BUSINESS MANAGEMENT; BUSINESS ADMINISTRATION; OFFICE FUNCTIONS (U.S. CLS. 100, 101 AND 102).

CLASS 38—COMMUNICATION

FOR TELECOMMUNICATIONS SERVICES, NAMELY, PROVIDING COMMUNICATION NETWORK TRANSMISSION SERVICES FOR ASSEMBLING AND SENDING INFORMATION AND SURVEILLANCE DATA FOR ALL OPERATIONS ON AN OILRIG AND INDUSTRIAL PLANT (U.S. CLS. 100, 101 AND 104).

CLASS 42—SCIENTIFIC AND COMPUTER SERVICES

FOR SCIENTIFIC AND TECHNOLOGICAL SERVICES, NAMELY, RESEARCH AND DESIGN IN THE FIELD OF THE SURVEILLANCE AND CONTROL OF ALL ACTIVITIES ON AN OIL RIG AND INDUSTRIAL PLANT; INDUSTRIAL ANALYSIS AND RESEARCH SERVICES IN THE FIELD OF OIL, OIL FIELDS AND OIL FIELD EXPLORATION; DESIGN AND DEVELOPMENT OF COMPUTER HARDWARE AND SOFTWARE; APPLICATION SERVICE PROVIDER FEATURING APPLICATION PROGRAMMING INTERFACE (API) FOR THIRD-PARTY SOFTWARE FOR PROFESSIONAL NETWORKING, BUILDING PROFESSIONAL NETWORKING APPLICATIONS, AND FOR ALLOWING DATA RETRIEVAL, UPLOAD, DOWNLOAD, ACCESS AND MANAGEMENT (U.S. CLS. 100 AND 101).

JOHN HWANG, EXAMINING ATTORNEY

SN 79-097,134. MAG. NIKOLAUS KIMLA UND UPTIME ITECHNOLGIES GMBH, AUSTRIA, FILED 10-13-2010.



PRIORITY DATE OF 10-13-2010 IS CLAIMED.
OWNER OF INTERNATIONAL REGISTRATION 1076472 DATED 10-13-2010, EXPIRES 10-13-2020.

THE COLOR(S) LIGHT BLUE AND ORANGE IS/ARE CLAIMED AS A FEATURE OF THE MARK.

THE MARK CONSISTS OF THE WORD "PIPELINER" IN LIGHT BLUE STYLIZED FONT WITH THE WORDING "THE UNIQUE SELLING POWER" IN ORANGE STYLIZED FONT BELOW THE WORD "PIPELINER" AND EXTENDING BEYOND THE LETTER "R" IN THE WORD "PIPELINER". THERE IS AN ABSTRACT DESIGN TO THE LEFT OF THE WORDING CONSISTING OF A DIAGONAL BAND COMPRISED OF FOUR LIGHT BLUE LINES, A CURVED BAND TO THE RIGHT OF THE DIAGONAL BAND COMPRISED OF FOUR LIGHT BLUE LINES AND A CURVED BAND ABOVE THE LOWER CURVED BAND COMPRISED OF FOUR ORANGE LINES. THE ABSTRACT DESIGN IS AIMED TO REPRESENT FOUR LETTERS "P" LEANING TO THE RIGHT AT AN ANGLE OF APPROXIMATELY 45 DEGREES AND TRYING TO ACHIEVE A THREE DIMENSIONAL EFFECT WHEREBY A TUBE IS VISIBLE LEFT TO THE LEFT OF THE FOUR ORANGE CURVED LINES.

CLASS 9—ELECTRICAL AND SCIENTIFIC APPARATUS

FOR SOFTWARE FOR THE MANAGEMENT OF THE ENTIRE SALES PROCESS BASED ON THE MANUAL OR ELECTRONIC INPUT OF VARIOUS CUSTOMER SPECIFIC DATA WHICH ARE GIVEN BY THE SOFTWARE AS WELL AS END USER SPECIFIC PRODUCT DETAILS AND SALES TEAM INFORMATION ENTERED INTO BY THE USER DURING THE INSTALLATION PROCESS OF THE SOFTWARE (U.S. CLS. 21, 23, 26, 36 AND 38).

CLASS 42—SCIENTIFIC AND COMPUTER SERVICES

FOR SOFTWARE DEVELOPMENT (U.S. CLS. 100 AND 101).

TINA BROWN, EXAMINING ATTORNEY

SN 79-097,150. AVIONS DE TRANSPORT REGIONAL, FRANCE, FILED 4-18-2011.

Propelling tomorrow's world

THE MARK CONSISTS OF STANDARD CHARACTERS WITHOUT CLAIM TO ANY PARTICULAR FONT, STYLE, SIZE, OR COLOR.

PRIORITY DATE OF 10-18-2010 IS CLAIMED.

OWNER OF INTERNATIONAL REGISTRATION 1076537 DATED 4-18-2011, EXPIRES 4-18-2021.

CLASS 12—VEHICLES

FOR AIR VEHICLES, NAMELY, AIRCRAFT, AIRPLANE, PLANE, SPACE VEHICLES, STRUCTURAL PARTS FOR AIRCRAFT (U.S. CLS. 19, 21, 23, 31, 35 AND 44).

CLASS 16—PAPER GOODS AND PRINTED MATTER

FOR PRINTED MATTER, NAMELY, NEWSPAPERS, CATALOGS, MAGAZINES, PRINTED PERIODICALS, TECHNICAL MANUALS ALL IN THE FIELD OF MOTORS AND ENGINES, AIRPLANES, AIRCRAFT AND SOFTWARE FOR THE AERONAUTICAL FIELD; PHOTOGRAPHS; SCHOOL SUPPLIES, NAMELY, WRITING AND DRAWING PAPER, NOTEBOOKS, DIARIES, EXERCISE BOOK, STICKERS AND AUTOGRAPHS; PAPER, PENCILS, PENCIL CASES, PENCIL HOLDERS AND PENCIL STANDS, PEN, ERASERS, DRAWING RULERS, PENCIL SHARPENERS; RING BINDER (U.S. CLS. 2, 5, 22, 23, 29, 37, 38 AND 50).

CLASS 37—CONSTRUCTION AND REPAIR

FOR MOTOR VEHICLE REPAIR, AIRPLANE MAINTENANCE AND REPAIR, PROVIDING INFORMATION ON REPAIR, CONSTRUCTION, AND MAINTENANCE OF AIRPLANES AND AIRCRAFT ENGINES; CUSTOM MANUFACTURE OF AIRPLANES (U.S. CLS. 100, 103 AND 106).

CLASS 39—TRANSPORTATION AND STORAGE

FOR AIR TRANSPORT, RENTAL OF WAREHOUSES, AIRPLANE CHARTERING, VEHICLE RENTAL, ARRANGEMENT OF TRAVEL TOURS, PASSENGER TRANSPORT, TRANSPORTATION INFORMATION, PACKAGING AND STORAGE OF STRUCTURAL PARTS OF AIRPLANES (U.S. CLS. 100 AND 105).

WILLIAM BRECKENFELD, EXAMINING ATTORNEY

SN 79-097,176. JAMES JOHNSTON & COMPANY OF ELGIN LIMITED, UNITED KINGDOM, FILED 3-16-2011.

JOHNSTONS OF ELGIN

THE MARK CONSISTS OF STANDARD CHARACTERS WITHOUT CLAIM TO ANY PARTICULAR FONT, STYLE, SIZE, OR COLOR.

OWNER OF INTERNATIONAL REGISTRATION 1076589 DATED 3-16-2011, EXPIRES 3-16-2021.

NO CLAIM IS MADE TO THE EXCLUSIVE RIGHT TO USE "OF ELGIN", APART FROM THE MARK AS SHOWN.

CLASS 24—FABRICS

FOR TEXTILE FABRICS FOR MANUFACTURE OF CLOTHING, FOOTWEAR, HEADWEAR; TEXTILE FABRICS FOR MANUFACTURE OF FURNITURE UPHOLSTERY, UNFITTED FABRIC FURNITURE COVERS, CURTAINS, DRAPERIES, CUSHIONS, AND CUSHION COVERS; TOWELS, TABLE NAPKINS OF TEXTILE, PLACE MATS OF TEXTILE MATERIAL, TEXTILE TABLE COVERS, BED SHEETS, PILLOW COVERS, BED BLANKETS, TRAVELLING RUGS, NAMELY, LAP ROBES; TEXTILE WALL HANGINGS (U.S. CLS. 42 AND 50).

CLASS 25—CLOTHING

FOR CLOTHING OF KNITTED AND WOVEN MATERIALS, NAMELY, PANTS, SHORTS, SWEATPANTS, SHIRTS, TEE-SHIRTS, SWEATSHIRTS, DRESSES, SKIRTS, BLOUSES, JACKETS, VESTS, COATS, CAPES, SWEATERS, CARDIGANS, GLOVES, SOCKS, HOSIERY, BELTS, SCARVES, SHAWLS, TIES; FOOTWEAR, NAMELY, SHOES, SLIPPERS, BOOTS AND BOOTIES; HEADGEAR, NAMELY, HATS, CAPS, HEADBANDS (U.S. CLS. 22 AND 39).

CLASS 27—FLOOR COVERINGS

FOR CARPETS, FLOOR COVERINGS, RUGS; CARPET TILES FOR COVERING FLOORS; FLOOR COVERINGS, NAMELY, FLOOR RUNNERS (U.S. CLS. 19, 20, 37, 42 AND 50).

JIM RINGLE, EXAMINING ATTORNEY

CLASS 35—ADVERTISING AND BUSINESS

FOR ADVERTISING, NAMELY, PROMOTION OF FINANCIAL AND INSURANCE SERVICES, ON BEHALF OF THIRD PARTIES; BUSINESS MANAGEMENT; BUSINESS ADMINISTRATION, NAMELY, DATA COMPILING AND ANALYZING IN THE FIELD OF INSURANCE, INSURANCE CLAIMS AUDITING SERVICES, INSURANCE LEAD COLLECTION AND MATCHING SERVICES, NAMELY, MATCHING CONSUMER REQUESTS FOR INSURANCE POLICY QUOTES COLLECTED OVER THE INTERNET TO PRE-QUALIFIED INSURANCE BROKERS, AGENTS AND AGENCIES INTERESTED IN THOSE REQUESTS, MANAGING THE OPERATIONS OF INSURANCE AGENCIES AND BROKERS ON AN OUTSOURCING BASIS, PROVIDING BUSINESS RESEARCH SERVICES, NAMELY, RESEARCHING DENTAL PATIENT INSURANCE INFORMATION FOR DENTAL OFFICES, PROVIDING HEALTH INSURANCE EXCHANGES IN THE NATURE OF A MARKETPLACE THAT OFFERS PURCHASERS OF HEALTH INSURANCE A VARIETY OF PLANS FROM DIFFERENT INSURANCE PROVIDERS, PROVIDING INSURANCE AGENT REFERRALS, PROVIDING STATISTICAL EVALUATION OF INSURANCE CLAIMS PERFORMANCE MEASURES FOR OTHERS; TRACKING AND MONITORING INSURANCE COMPLIANCE; OFFICE FUNCTIONS (U.S. CLS. 100, 101 AND 102).

CLASS 36—INSURANCE AND FINANCIAL

FOR INSURANCE, NAMELY, ADMINISTRATION OF EMPLOYEE WELFARE, BENEFIT AND HEALTH INSURANCE PLANS CONCERNING INSURANCE AND FINANCE, ADVISORY SERVICES IN THE FIELD OF EMPLOYEE BENEFITS FOR GROUP HEALTHCARE AND BUSINESS INSURANCE OFFERED TO EMPLOYEES IN ADDITION TO STANDARD BENEFITS SUCH AS MEDICAL, DENTAL, LIFE INSURANCE INCLUDING SHORT TERM DISABILITY, LONG TERM DISABILITY, CANCER INSURANCE, ACCIDENTAL DEATH AND DISMEMBERMENT, ASSESSING INSURANCE CLAIMS, BROKERAGE IN THE FIELD OF HEALTH AND DENTAL INSURANCE, CLAIMS ADJUSTMENT IN THE FIELD OF INSURANCE, CLAIMS ADMINISTRATION SERVICES IN THE FIELD OF HEALTH INSURANCE, CONSULTING AND INFORMATION CONCERNING INSURANCE, DENTAL HEALTH INSURANCE UNDERWRITING AND ADMINISTRATION, DENTAL HEALTH INSURANCE ADMINISTRATION, DESIGN AND DEVELOPMENT OF INSURANCE POLICIES FOR OTHERS, ELECTRONIC PROCESSING OF INSURANCE CLAIMS AND PAYMENT DATA, FINANCIAL EVALUATION FOR INSURANCE PURPOSES, HEALTH INSURANCE UNDERWRITING, HEALTHCARE INSURANCE SERVICES FOR LASIK SURGERY, INSURANCE ACTUARIAL SERVICES, INSURANCE ADMINISTRATION IN THE FIELD OF HEALTH AND DENTAL INSURANCE FOR EXPATS; PROVIDING THIRD-PARTY INSURANCE ADMINISTRATION IN THE FIELD OF HEALTH INSURANCE AND INTERNATIONAL HEALTH AND DENTAL INSURANCE FOR EXPATS; INSURANCE ADMINISTRATION; INSURANCE ADMINISTRATION SERVICES, NAMELY, ASSISTING OTHERS WITH COLLECTING INSURANCE PREMIUMS AND ASSISTING OTHERS WITH ADJUSTING INSURANCE CLAIMS; INSURANCE AGENCIES; INSURANCE AGENCIES IN THE FIELD OF HEALTH AND DENTAL INSURANCE FOR EXPATS; INSURANCE AGENCY AND BROKERAGE; INSURANCE AND FINANCIAL INFORMATION AND CONSULTANCY SERVICES; INSURANCE BROKERAGE; INSURANCE BROKERAGE IN THE FIELD OF HEALTH AND DENTAL INSURANCE FOR EXPATS; INSURANCE BROKERAGE SERVICES; INSURANCE CARRIER SERVICES; INSURANCE CLAIMS ADMINISTRATION; INSURANCE CLAIMS PROCESSING; INSURANCE CONSULTANCY; INSURANCE CONSULTATION; INSURANCE CONSULTING IN THE FIELD OF HEALTH AND DENTAL INSURANCE FOR EXPATS; INSURANCE INFORMATION; INSURANCE INFORMATION AND CONSULTANCY; INSURANCE PREMIUM RATE COMPUTING; INSURANCE SERVICES, NAMELY, PROVIDING INFORMATION AND ON-LINE COMPUTER DATABASES FOR THE PURPOSE OF REVIEW AND VERIFICATION OF MEDICAID AND MEDICARE ELIGIBILITY STATUS AND RELATED INFORMATION; INSURANCE SERVICES, NAMELY, PROVIDING INDEPENDENT SCORING SERVICE RELATED

SN 79-097.305. DKV GLOBALITY S.A., LUXEMBOURG, FILED 4-4-2011.



PRIORITY DATE OF 10-5-2010 IS CLAIMED.
OWNER OF INTERNATIONAL REGISTRATION 1076891 DATED 4-4-2011, EXPIRES 4-4-2021.

NO CLAIM IS MADE TO THE EXCLUSIVE RIGHT TO USE "HEALTHCARE SERVICE SATELLITES", APART FROM THE MARK AS SHOWN.

THE COLOR(S) LIGHT GREEN, DARK GREEN AND PURPLE IS/ARE CLAIMED AS A FEATURE OF THE MARK.

THE MARK CONSISTS OF THE WORDS "GLOBALITES HEALTHCARE SERVICE SATELLITES", WITH THE LETTER "O" IN "GLOBALITES" COMPRISING A PLANET DESIGN FEATURING A RING AND TWO ORBITING SPHERES. THE LETTERS "G", "L", "B", "A", "L", "I", "T", "E", AND "S" IN "GLOBALITES" ARE DARK GREEN, THE WORDING "HEALTHCARE SERVICE SATELLITES" IS PURPLE. THE PLANET DESIGN IS LIGHT GREEN ON THE UPPER RIGHT HALF OF THE ORB, DARK GREEN ON THE LOWER LEFT HALF OF THE ORB, AND THE RING AND ORBITING SPHERES ARE PURPLE. THE COLOR WHITE IS MERE BACKGROUND.

CLASS 10—MEDICAL APPARATUS

FOR MEDICAL, APPARATUS, NAMELY, STRETCHERS FOR PATIENT TRANSPORT (U.S. CLS. 26, 39 AND 44).

TO EXISTING MEDICAL SERVICES IN A SPECIFIC GEOGRAPHIC REGION FOR INSURANCE EVALUATION PURPOSES; INSURANCE SERVICES, NAMELY, UNDERWRITING HEALTH AND DENTAL INSURANCE; INSURANCE SERVICES, NAMELY, INSURANCE ELIGIBILITY REVIEW AND VERIFICATION AND CONSULTATION IN THE HEALTH AND DENTAL INDUSTRY; INSURANCE SERVICES, NAMELY, UNDERWRITING, ISSUANCE AND ADMINISTRATION OF HEALTH AND DENTAL INSURANCES; INSURANCE SERVICES, PROVIDING PREMIUM RATE QUOTES VIA ON-LINE, TELEPHONE AND MAIL MEANS; INSURANCE SUBROGATION; INSURANCE UNDERWRITING IN THE FIELD OF HEALTH AND DENTAL FOR EXPATS; INSURANCE UNDERWRITING SERVICES FOR ALL TYPES OF INSURANCE; INSURANCE UNDERWRITING CONSULTATION; MEDICAL INSURANCE CASE AND UTILIZATION REVIEW AND INSURANCE CLAIMS ADJUSTMENT SERVICES FOR HEALTHCARE PURCHASERS AND PAYORS AND PROVIDERS AND MEDICARE BENEFICIARIES; MEDICAL INSURANCE UNDERWRITING; PROCESSING, ADMINISTERING AND MANAGING EMPLOYEE BENEFIT PLANS CONCERNING INSURANCE AND FINANCE; PROVIDING A DATABASE FOR TRACKING, MONITORING, AND GENERATING REPORTS ON INFORMATION AND STATISTICS ABOUT PATIENT REIMBURSEMENT AND INSURANCE COVERAGE FOR PHARMACEUTICALS AND MEDICAL DEVICES; PROVIDING INFORMATION IN INSURANCE MATTERS; PROVIDING INFORMATION REGARDING POLICY RATES FOR ALL TYPES OF INSURANCE AND ELECTRONIC PROCESSING OF INSURANCE CLAIMS AND PAYMENT DATA OVER A WEB BASED COMPUTER NETWORK; UNDERWRITING INSURANCE FOR PRE-PAID HEALTH CARE (U.S. CLS. 100, 101 AND 102).

CLASS 39—TRANSPORTATION AND STORAGE

FOR TRANSPORT, NAMELY, AMBULANCE TRANSPORT, MEDICAL TRANSPORT SERVICES, PRE-PAID AIR AMBULANCE TRANSPORT SERVICES; CONSULTING SERVICES IN THE FIELD OF AIR MEDICAL OPERATIONS IN THE NATURE OF AIR MEDICAL TRANSPORT (U.S. CLS. 100 AND 105).

CLASS 44—MEDICAL, BEAUTY AND AGRICULTURAL SERVICES

FOR MEDICAL SERVICES (U.S. CLS. 100 AND 101).

CLASS 45—PERSONAL AND LEGAL SERVICES

FOR LEGAL SERVICES (U.S. CLS. 100 AND 101).
DOMINICK J. SALEMI, EXAMINING ATTORNEY

SN 79-097,536. FEDRIGONI S.P.A., ITALY, FILED 10-1-2010.



OWNER OF INTERNATIONAL REGISTRATION 0907976
DATED 6-16-2006, EXPIRES 6-16-2016.

THE MARK CONSISTS OF A SIGN REPRESENTING THE LETTER "C" IN FANCY CHARACTERS; INSIDE OF ITS CONCAVITY THERE IS THE FIGURE OF A STYLIZED SHIELD IN WHICH THERE IS THE FIGURE OF A STYLIZED LADDER AND OUTSIDE OF SAID SHIELD THERE ARE TWO STYLIZED, PARALLEL PARTS OF A BENDED LINE.

CLASS 16—PAPER GOODS AND PRINTED MATTER

FOR CARDBOARD, BOND PAPER, ILLUSTRATION PAPER, LINING PAPER, PADDING PAPER, PRINTING PAPER, REPRODUCTION PAPER, WRITING PAPER, PUBLICATION PAPER, COPY PAPER, CORRUGATED PAPER, PAPER FILES, CARD FILE, TYPEWRITER PAPER, COMPUTER PAPER, NEWSPRINT PAPER, PAPER ILLUSTRATION BOARDS, PAPERBOARD, PAPER BOXES, PAPER PADS, GREETING CARDS, BUSINESS CARDS, MAGNETIC BOARDS, ENVELOPES, LETTER OPENERS, STATIONERY IN THE NATURE OF STICKERS, PAPER BAGS, BOOK COVERS, BOOKKEEPING BOOKS, ADDRESS BOOKS, CHECK BOOK COVERS, NOTEBOOKS, EXERCISES BOOKS, DIARIES, CALENARS, ALMANACS, SCRAPBOOKS, POSTERS, FILE FOLDERS, HANGING FOLDERS, PRICE TICKETS, CATALOGUES IN THE FIELD OF PAPER PRODUCTS AND ART REPRODUCTIONS, PRINTED AND GRAPHIC ART REPRODUCTIONS, CARDBOARD LABELS, PAPER FILE JACKETS, PHOTOGRAPHS, NEWSPAPERS FOR GENERAL CIRCULATION, MAGAZINES IN THE FIELD OF PAPER PRODUCTS AND ART REPRODUCTIONS (U.S. CLS. 2, 5, 22, 23, 29, 37, 38 AND 50).

CLASS 41—EDUCATION AND ENTERTAINMENT

FOR EDUCATIONAL SERVICES, NAMELY, PROVIDING INSTRUCTION RELATING TO ARTS, CRAFTS AND GENERAL KNOWLEDGE, EDUCATIONAL DEMONSTRATIONS AND ENTERTAINMENT EXHIBITIONS IN THE NATURE OF PAPER AND PAPER PRODUCTS EXHIBITIONS, ART EXHIBITIONS, ARRANGING AND CONDUCTION OF EDUCATIONAL CONFERENCES, PUBLICATION OF BOOKS AND MAGAZINES, ORGANIZATION OF EXHIBITIONS FOR EDUCATIONAL, CULTURAL, SPORTING OR ENTERTAINMENT PURPOSES, EDUCATIONAL SERVICES IN THE NATURE OF FINE ARTS SCHOOLS, CONDUCTING WORKSHOPS AND SEMINARS IN FINE ARTS, INFORMATION ABOUT EDUCATION, TRAINING IN THE FIELD OF ARTS AND CRAFTS (U.S. CLS. 100, 101 AND 107).

LINDA ESTRADA, EXAMINING ATTORNEY

SN 79-097,553. NIMCO SCHOENBEDRIJVEN B.V., NETHERLANDS, FILED 5-4-2011.



PRIORITY DATE OF 12-13-2010 IS CLAIMED.
OWNER OF INTERNATIONAL REGISTRATION 1077620
DATED 5-4-2011, EXPIRES 5-4-2021.

THE MARK CONSISTS OF THE WORDING "MYWALKER" TO THE RIGHT OF A DESIGN OF TWO SHOE SOLES.

CLASS 10—MEDICAL APPARATUS

FOR ORTHOPEDIC FOOTWEAR (U.S. CLS. 26, 39 AND 44).

CLASS 25—CLOTHING

FOR FOOTWEAR (U.S. CLS. 22 AND 39).
DAVID HOFFMAN, EXAMINING ATTORNEY

SN 79-097,874. GIOBATTÀ E PIERO GARBELLOTO S.P.A., ITALY, FILED 3-30-2011.

The Experience

PRIORITY DATE OF 3-24-2011 IS CLAIMED.
OWNER OF INTERNATIONAL REGISTRATION 1078646
DATED 3-30-2011, EXPIRES 3-30-2021.

CLASS 6—METAL GOODS

FOR CASKS OF METAL (U.S. CLS. 2, 12, 13, 14, 23, 25 AND 50).

CLASS 20—FURNITURE AND ARTICLES NOT OTHERWISE CLASSIFIED

FOR CASKS OF WOOD (U.S. CLS. 2, 13, 22, 25, 32 AND 50).
CHRISTINE MARTIN, EXAMINING ATTORNEY

SN 79-097,954. IGELELEKTRONIK GMBH, FED REP GERMANY, FILED 3-25-2011.

MV-CS

THE MARK CONSISTS OF STANDARD CHARACTERS WITHOUT CLAIM TO ANY PARTICULAR FONT, STYLE, SIZE, OR COLOR.

PRIORITY DATE OF 9-27-2010 IS CLAIMED.
OWNER OF INTERNATIONAL REGISTRATION 1078900
DATED 3-25-2011, EXPIRES 3-25-2021.

CLASS 9—ELECTRICAL AND SCIENTIFIC APPARATUS

FOR SWITCHING, ADJUSTING AND CONTROL DEVICES, NAMELY, ELECTRONIC SWITCHING, ADJUSTING AND CONTROL DEVICES FOR ELECTRICITY; PROGRAMMABLE SWITCHING, ADJUSTING, CONTROL AND AUTOMATION DEVICES, NAMELY, ELECTRONIC PROGRAMMABLE SWITCHING, ADJUSTING AND CONTROL DEVICES FOR ELECTRICITY; ELECTRONIC COMPONENTS, NAMELY, SWITCHGEAR, SWITCHES; ELECTRONIC ASSEMBLIES FOR USE WITH MOTORS, PUMPS, FANS, COMPRESSORS, CHILLERS, SHREDDERS, MILLS, CRUSHERS, CONVEYOR BELTS, MILLING MACHINES, SAWS, MIXERS, BLOWER, SCREW CONVEYORS, CENTRIFUGE, CEMENT PUMPS; INDUSTRIAL ELECTRONICS DEVICES AND POWER ELECTRONICS DEVICES, INCLUDED IN THIS CLASS, NAMELY, ELECTRONIC CONTROL RELAYS AND TIME RELAYS, ELECTRONIC SWITCHING RELAYS, ELECTRONIC CONTACTORS (SWITCHES), ELECTRONIC TRIGGERS FOR PROTECTIVE SWITCHES IN THE NATURE OF POWER SWITCHES AND MOTOR PROTECTIVE SWITCHES; ELECTRIC PROTECTIVE SWITCHES OF ALL TYPES AND FOR

ALL VOLTAGES AND ALL CURRENT STRENGTHS INCLUDED IN THIS CLASS, NAMELY, POWER SWITCHES, POWER LINE SWITCHES, MOTOR SWITCHES, PLANT SWITCHES AND OVERVOLTAGE PROTECTIVE SWITCHES, OVER CURRENT PROTECTIVE SWITCHES, TEMPERATURE SWITCHES, TIME SWITCHES AND PROTECTIVE ELECTRIC RELAYS, CIRCUIT BREAKERS, CONTACTORS POWER SWITCHES, FUSES, OVERVOLTAGE DIVERTERS, ELECTRIC SWITCH ACTUATORS, ELECTRIC SWITCH CLOCKS NOT FOR CLOCK MECHANISMS, ELECTRIC POSITION SWITCHES, ELECTRIC SELECTOR SWITCHES, ELECTRIC SAFETY SWITCHES, SETS COMPRISED OF ELECTRIC PROTECTIVE SWITCHES OF ALL TYPES AND FOR ALL VOLTAGES AND ALL CURRENT STRENGTHS INCLUDED IN THIS CLASS; APPARATUS AND INSTRUMENTS FOR CONDUCTING, SWITCHING, CONVERTING, STORING, ADJUSTING AND CONTROLLING ELECTRICITY FOR MOTORS, PUMPS, FANS, COMPRESSORS, CHILLERS, SHREDDERS, MILLS, CRUSHERS, CONVEYOR BELTS, MILLING MACHINES, SAWS, MIXERS, BLOWER, SCREW CONVEYORS, CENTRIFUGE, CEMENT PUMPS; ELECTRICAL AND ELECTRONIC APPARATUS FOR PROTECTING PERSONS AND SYSTEMS AGAINST DAMAGE BY ELECTRIC CURRENTS, VOLTAGES AND ARCS, NAMELY, COMPONENTS IN THE NATURE OF PROTECTION RELAYS, FUSES, CIRCUIT BREAKERS; INSERTABLE AND EXTENDABLE UNITS FOR SWITCHING DEVICES IN POWER DISTRIBUTION SYSTEMS, NAMELY, DISTRIBUTION BOXES FOR ELECTRICAL POWER, POWER SUPPLIES, TRANSFORMERS, SWITCHES; ELECTRIC CONDUCTOR RAIL DISTRIBUTORS; POWER SUPPLIES; SWITCHING AND CONTROL DEVICES FOR ELECTRIC MOTORS, NAMELY, SMOOTH STARTERS, THYRISTOR CONTROLLERS, ELECTRICAL AND/OR ELECTRONIC DEVICES FOR ROTATIONAL SPEED CONTROL OF ELECTRIC MOTORS, IN THE NATURE OF FREQUENCY CONVERTERS FOR THREE-PHASE MOTORS; ELECTRICAL TRANSFORMERS, ELECTRICAL CHOKES INDUCTORS; DEVICES FOR POWER AND FREQUENCY CONVERSION, NAMELY, ELECTRICAL POWER CONVERTERS AND FREQUENCY CONVERTERS; ELECTRICAL SWITCH HOUSINGS OF METAL AND/OR SYNTHETIC MATERIAL; ELECTRICAL ALARMS FOR MONITORING AND SECURING ELECTRICAL SWITCH HOUSINGS; ELECTRICAL AND/OR ELECTRONIC DEVICES FOR PROTECTING CATHODES AGAINST CORROSION, NAMELY, CATHODIC CORROSION PROTECTION (U.S. CLS. 21, 23, 26, 36 AND 38).

CLASS 37—CONSTRUCTION AND REPAIR

FOR INSTALLATION, REPAIR, REFITTING MAINTENANCE AND REMOTE MAINTENANCE OF APPARATUS AND INSTRUMENTS FOR CONDUCTING, SWITCHING, CONVERTING, STORING, ADJUSTING AND CONTROLLING ELECTRICITY; INSTALLATION, REPAIR, REFITTING, MAINTENANCE AND REMOTE MAINTENANCE OF ELECTRONIC SWITCHING, ADJUSTING AND CONTROL DEVICES AND ELECTRONIC PROGRAMMABLE SWITCHING, ADJUSTING, CONTROL AND AUTOMATION DEVICES; INSTALLATION, REPAIR, REFITTING, MAINTENANCE AND REPORT MAINTENANCE OF INDUSTRIAL ELECTRONICS DEVICES AND POWER ELECTRONICS DEVICES; INSTALLATION, REPAIR, REFITTING, MAINTENANCE AND REMOTE MAINTENANCE OF SWITCHING AND CONTROL DEVICES FOR ELECTRIC MOTORS; INSTALLATION, REPAIR, REFITTING, MAINTENANCE AND REMOTE MAINTENANCE OF ELECTRICAL SWITCH HOUSINGS OF METAL AND/OR SYNTHETIC MATERIAL; INSTALLATION, REPAIR, REFITTING, MAINTENANCE AND REMOTE MAINTENANCE OF ELECTRICAL AND/OR ELECTRONIC DEVICES FOR PROTECTING CATHODES AGAINST CORROSION (U.S. CLS. 100, 103 AND 106).

KAELIE KUNG, EXAMINING ATTORNEY

SN 79-097,974. PEDRI JEAN-ROCH, PARIS, FRANCE, FILED 1-21-2011.

JOHN-ROCH

THE MARK CONSISTS OF STANDARD CHARACTERS WITHOUT CLAIM TO ANY PARTICULAR FONT, STYLE, SIZE, OR COLOR.

PRIORITY DATE OF 7-23-2010 IS CLAIMED.

OWNER OF INTERNATIONAL REGISTRATION 1078970 DATED 1-21-2011, EXPIRES 1-21-2021.

THE NAME(S), PORTRAIT(S), AND/OR SIGNATURE(S) SHOWN IN THE MARK IDENTIFIES JEAN-ROCH PEDRI, WHOSE CONSENT(S) TO REGISTER IS MADE OF RECORD.

CLASS 3—COSMETICS AND CLEANING PREPARATIONS

FOR BLEACHING PREPARATIONS AND DETERGENT FOR LAUNDRY USE; CLEANING, POLISHING, AND SCOURING PREPARATIONS; ABRASIVE LIQUIDS AND POWDERS FOR GENERAL PURPOSE CLEANING; SOAP FOR HOUSEHOLD AND PERSONAL USE; PERFUMERY, ESSENTIAL OILS, COSMETICS, HAIR LOTIONS; DENTIFRICES (U.S. CLS. 1, 4, 6, 50, 51 AND 52).

CLASS 9—ELECTRICAL AND SCIENTIFIC APPARATUS

FOR APPARATUS FOR RECORDING, TRANSMISSION OR REPRODUCTION OF SOUND OR IMAGES; PRERECORDED VIDEO TAPES FEATURING MUSIC; RECORDINGS FEATURING MUSIC, NAMELY, AUDIO DISCS, COMPACT DISCS, DIGITAL AUDIO DISCS, DIGITAL AUDIO COMPACT DISCS, AUDIO TAPES, AUDIO CASSETTES, VIDEO TAPES, VIDEO CASSETTES, MAGNETIC TAPES, AND MAGNETIC DISCS, ALL CONTAINING AUDIO OR VIDEO RECORDINGS FEATURING MUSIC; CABLES FOR CARRYING AUDIO AND VIDEO; OPTICAL DISCS CONTAINING AUDIO OR VIDEO RECORDINGS FEATURING MUSIC; COMPUTER PROGRAMS USED FOR DOWNLOADING MUSIC; COMPUTER SOFTWARE USED FOR PROCESSING DIGITAL MUSIC FILES; DOWNLOADABLE COMPUTER SOFTWARE USED FOR COMPOSING MUSIC; DOWNLOADABLE ELECTRONIC NEWSLETTERS FEATURING MUSIC REVIEWS AND NEWS IN THE NATURE OF CURRENT EVENTS IN THE MUSIC INDUSTRY; CD-ROMS FEATURING MUSIC; DVDS FEATURING MUSIC; DIGITAL MUSIC DOWNLOADABLE FROM THE INTERNET; DOWNLOADABLE MP3 FILES AND MP3 RECORDINGS FEATURING MUSIC; MP3 PLAYERS (U.S. CLS. 21, 23, 26, 36 AND 38).

CLASS 32—LIGHT BEVERAGES

FOR BEER; MINERAL AND AERATED WATERS; SOFT DRINKS; PREPARATIONS FOR MAKING BEVERAGES EXCEPT THOSE MADE WITH COFFEE, TEA OR COCOA AND MILK BEVERAGES, NAMELY, CONCENTRATES, SYRUPS OR POWDERS USED IN THE PREPARATION OF SOFT DRINKS; FRUIT DRINKS AND FRUIT JUICES; SYRUPS FOR MAKING FRUIT-FLAVORED DRINKS (U.S. CLS. 45, 46 AND 48).

CLASS 33—WINES AND SPIRITS

FOR ALCOHOLIC BEVERAGES EXCEPT BEERS (U.S. CLS. 47 AND 49).

CLASS 35—ADVERTISING AND BUSINESS

FOR ADVERTISING, PROMOTION AND MARKETING SERVICES; BUSINESS MANAGEMENT AND BUSINESS ADMINISTRATION; RETAIL STORE SERVICES IN THE FIELD OF SOUND RECORDING DISKS, COMPACT DISKS, AUDIO AND VIDEO CASSETTES, TAPES AND CARTRIDGES, MAGNETIC CASSETTES, TAPES, AND DISKS, ALL CONTAINING AUDIO OR VIDEO RECORDINGS, CABLES FOR CARRYING AUDIO AND VIDEO, CD-ROMS, AND MP3 PLAYERS; COMPILATION OF ADVERTISEMENTS FOR USE AS WEB PAGES ON THE INTERNET; RENTAL OF ADVERTISING SPACE ON WEB SITES FOR ADVERTISING THE GOODS AND SERVICES OF OTHERS; PROVIDING INFORMATION AND CONSULTING SERVICES IN THE FIELDS OF ADVERTISING, MARKETING, BUSINESS MANAGEMENT, BUSINESS ADMINISTRATION, RETAIL STORE SERVICES, AND RENTAL OF ADVERTISING SPACE ON WEB SITES (U.S. CLS. 100, 101 AND 102).

CLASS 38—COMMUNICATION

FOR TELECOMMUNICATION ACCESS SERVICES; COMMUNICATIONS VIA COMPUTER TERMINALS AND VIA FIBER-OPTIC NETWORKS; RADIO AND TELEPHONE COMMUNICATION; INTERNET BROADCASTING OF RADIO AND TELEVISION ENTERTAINMENT; AUDIO BROADCASTING OF MUSIC; NEWS AGENCY SERVICES FOR ELECTRONIC TRANSMISSION; ELECTRONIC TRANSMISSION OF DATA OR DOCUMENTS BY MEANS OF COMPUTER TERMINALS, RADIO, CABLE, SATELLITE, AND THE INTERNET; ELECTRONIC MAIL SERVICES (U.S. CLS. 100, 101 AND 104).

CLASS 41—EDUCATION AND ENTERTAINMENT

FOR TEACHING IN THE FIELD OF MUSIC; TRAINING SERVICES IN THE FIELD OF MUSIC; ENTERTAINMENT IN THE NATURE OF VISUAL AND AUDIO PERFORMANCES, AND MUSICAL, VARIETY, NEWS AND COMEDY SHOWS; ORGANIZING COMMUNITY SPORTING AND CULTURAL EVENTS; PROVIDING INFORMATION ON ENTERTAINMENT AND EDUCATION; PROVIDING RECREATION FACILITIES; ORGANIZATION OF SINGING AND DANCE COMPETITIONS; PUBLICATION OF BOOKS; LENDING LIBRARIES; EDUCATIONAL SERVICES, NAMELY, ARRANGING AND CONDUCTING OF EDUCATIONAL COLLOQUIUMS, CONFERENCES, AND CONGRESSES IN THE FIELD OF MUSIC; ORGANIZATION OF EXHIBITIONS FOR CULTURAL OR EDUCATIONAL PURPOSES; BOOKING OF SEATS FOR SHOWS; PRESENTATION OF LIVE SHOW PERFORMANCES OF VOCAL AND INSTRUMENTAL GROUPS; AUDIO AND VIDEO RECORDING SERVICES; PRODUCTION OF RADIO AND TELEVISION PROGRAMS; AUDIO AND VIDEO PRODUCTION OF AUDIO AND VIDEO RECORDINGS; PRODUCTION OF LIVE THEATER SHOWS, MUSICAL ENTERTAINMENT LIVE SHOWS, CONCERTS, VIDEOS, MULTIMEDIA VIDEOS AND RADIO AND TELEVISION PROGRAMS; CINEMA THEATERS; RECORDING STUDIO SERVICES; VIDEO AND TELEVISION SHOW PRODUCTION SERVICES; AUDIO RECORDING SERVICES; CINEMATOGRAPHIC SERVICES, NAMELY, MOVIE FILMING SERVICES; VIDEO AND TELEVISION FILMING SERVICES; MUSIC PUBLISHING SERVICES; PRODUCTION SERVICES FOR SOUND RECORDINGS, FILMS AND VIDEOS; ENTERTAINMENT SERVICES, NAMELY, PROVIDING NON-DOWNLOADABLE PLAYBACK OF MUSIC VIA GLOBAL COMMUNICATIONS NETWORKS; ENTERTAINMENT SERVICES, NAMELY, NON-DOWNLOADABLE PRE-RECORDED MUSIC PRESENTED TO MOBILE COMMUNICATIONS DEVICES VIA A GLOBAL COMPUTER NETWORK AND WIRELESS NETWORKS; PUBLISHING OF ELECTRONIC PUBLICATIONS, NAMELY, ON-LINE PUBLISHING OF NON-DOWNLOADABLE ELECTRONIC PUBLICATIONS; ARRANGING AND CONDUCTING NIGHTCLUB ENTERTAINMENT EVENTS; DISCOTHEQUE SERVICES (U.S. CLS. 100, 101 AND 107).

CLASS 43—HOTEL AND RESTAURANT SERVICES

FOR BAR SERVICES; CAFE AND COFFEE SHOP SERVICES, CAFETERIAS, HOTEL SERVICES, CATERING SERVICES (U.S. CLS. 100 AND 101).

KATHERINE STOIDES, EXAMINING ATTORNEY

CLASS 35—ADVERTISING AND BUSINESS

FOR DISSEMINATION OF ADVERTISING IN THE FIELD OF PHARMACEUTICAL PRODUCTS AND IN THE FIELD OF CONTRAST MEDIA FOR IN-VIVO IMAGING; ADVERTISING SERVICES IN THE FIELD OF PHARMACEUTICAL PRODUCTS AND IN THE FIELD OF CONTRAST MEDIA FOR IN-VIVO IMAGING, NAMELY, PROMOTING THE GOODS AND SERVICES OF OTHERS THROUGH THE DISSEMINATION OF PRINTED MATTER, NAMELY PAMPHLETS, MANUALS, AND LEAFLETS (U.S. CLS. 100, 101 AND 102).

CLASS 41—EDUCATION AND ENTERTAINMENT

FOR EDUCATIONAL SERVICES, NAMELY, CONDUCTING SEMINARS, CONFERENCES AND WORKSHOPS IN THE FIELD OF PHARMACEUTICAL PRODUCTS AND CONTRAST MEDIA FOR IN-VIVO IMAGING AND DISTRIBUTING COURSE MATERIALS IN CONNECTION THEREWITH (U.S. CLS. 100, 101 AND 107).

CLASS 42—SCIENTIFIC AND COMPUTER SERVICES

FOR MEDICAL AND SCIENTIFIC RESEARCH SERVICES PERTAINING TO THE DIAGNOSIS OF MEDICAL CONDITIONS IN INDIVIDUALS (U.S. CLS. 100 AND 101).

JEAN IM, EXAMINING ATTORNEY

SN 79-098,089. BRACCO S.P.A., ITALY, FILED 12-2-2010.



OWNER OF INTERNATIONAL REGISTRATION 0757487 DATED 4-9-2001, EXPIRES 4-9-2021.

OWNER OF U.S. REG. NO. 3,324,902.

NO CLAIM IS MADE TO THE EXCLUSIVE RIGHT TO USE "IMAGING", APART FROM THE MARK AS SHOWN.

THE COLOR(S) BLUE PANTONE (280) AND GREEN PANTONE (348) IS/ARE CLAIMED AS A FEATURE OF THE MARK.

THE MARK CONSISTS OF THE STYLIZED WORDING "BRACCO" IN GREEN PANTONE 348, "IMAGING" IN BLUE PANTONE 280, AND THE DESIGN OF A POLYGON COMPRISED OF LINES IN BLUE PANTONE 280 AND GREEN PANTONE 348.

CLASS 5—PHARMACEUTICALS

FOR PHARMACEUTICAL PREPARATIONS, NAMELY, CONTRAST MEDIA AND CONTRASTING AGENTS FOR DIAGNOSTIC AND IN-VIVO IMAGING (U.S. CLS. 6, 18, 44, 46, 51 AND 52).

CLASS 10—MEDICAL APPARATUS

FOR MEDICAL INSTRUMENTS AND APPARATUS FOR DIAGNOSTIC IMAGING PROCEDURES SUCH AS X-RAY, MAGNETIC RESONANCE, ULTRASOUND AND NUCLEAR MEDICINE, NAMELY, ULTRASONIC SURGICAL ASPIRATORS, ULTRASOUND IMAGING SCANNERS, INJECTION PUMPS, AND OTHER ELECTROMAGNETIC MEDICAL DIAGNOSTIC IMAGING APPARATUS, NAMELY, TUBES, CATHETERS AND GUIDEWIRES; AND PARTS AND FITTINGS FOR THE AFORESAID GOODS (U.S. CLS. 26, 39 AND 44).

CLASS 16—PAPER GOODS AND PRINTED MATTER

FOR PRINTED MATERIALS, NAMELY, PAMPHLETS, MANUALS, LEAFLETS RELATING TO PHARMACEUTICAL PRODUCTS AND IN-VIVO IMAGING SERVICES (U.S. CLS. 2, 5, 22, 23, 29, 37, 38 AND 50).

SN 79-098,135. MARS DRINKS UK LIMITED, UNITED KINGDOM, FILED 1-21-2011.

Foundry Blend

THE MARK CONSISTS OF STANDARD CHARACTERS WITHOUT CLAIM TO ANY PARTICULAR FONT, STYLE, SIZE, OR COLOR.

PRIORITY DATE OF 7-30-2010 IS CLAIMED.

OWNER OF INTERNATIONAL REGISTRATION 1079331 DATED 1-21-2011, EXPIRES 1-21-2021.

NO CLAIM IS MADE TO THE EXCLUSIVE RIGHT TO USE "BLEND", APART FROM THE MARK AS SHOWN.

CLASS 30—STAPLE FOODS

FOR COFFEE, ESPRESSO; TEA, NON-MEDICINAL HERBAL TEA; COCOA, HOT CHOCOLATE; ARTIFICIAL COFFEE, COFFEE SUBSTITUTES, CHICORY AND CHICORY MIXTURES, ALL FOR USE AS SUBSTITUTES FOR COFFEE; MIXTURES OF COFFEE AND CHICORY; WHOLE BEAN, GROUND AND ROASTED COFFEE; BEVERAGES, BEVERAGE MIXES, AND BEVERAGE CONCENTRATES BASED ON COFFEE, ESPRESSO, TEA, NON-MEDICINAL HERBAL TEA, COCOA, CHOCOLATE, ARTIFICIAL COFFEE, COFFEE SUBSTITUTES, AND CHICORY; COFFEE EXTRACTS, NON-MEDICINAL HERBAL TEA EXTRACTS, AND COCOA EXTRACTS, ALL FOR HUMAN CONSUMPTION; FLAVORING SYRUPS FOR BEVERAGES; FLAVORING POWDERS FOR TEA AND COFFEE-BASED BEVERAGES (U.S. CL. 46).

CLASS 35—ADVERTISING AND BUSINESS

FOR RETAIL STORE SERVICES, MAIL ORDER RETAIL SERVICES, CATALOGUE AND ONLINE RETAIL STORE SERVICES ALL FEATURING COFFEE, ESPRESSO, TEA, HERBAL TEA, COCOA, ARTIFICIAL COFFEE, COFFEE SUBSTITUTES, CHICORY AND CHICORY MIXES, WHOLE BEAN, GROUND AND ROASTED COFFEE, BEVERAGES, MIXES, EXTRACTS AND CONCENTRATES BASED ON COFFEE, ESPRESSO, TEA, HERBAL TEA, COCOA, CHOCOLATE, ARTIFICIAL COFFEE, COFFEE SUBSTITUTES AND CHICORY, FOOD AND BEVERAGES, FLAVOURING SYRUPS AND POWDERS FOR BEVERAGES, ELECTRIC AND NON-ELECTRIC COFFEE, ESPRESSO, TEA AND HOT CHOCOLATE BREWERS, MAKERS AND PREPARATION EQUIPMENT AND ACCESSORIES, BEVERAGE CUPS AND CONTAINERS (U.S. CLS. 100, 101 AND 102).

CLASS 43—HOTEL AND RESTAURANT SERVICES

FOR SERVICES FOR PROVIDING FOOD AND DRINK; RESTAURANT, CAFE, COFFEE SHOP, COFFEE BAR, TEA ROOM, CAFETERIA, CANTEEN, FAST FOOD, DELI, SNACK BAR, SELF-SERVICE RESTAURANT, CARRY-OUT RESTAURANT, DRIVE-THROUGH RESTAURANT SERVICES; CATERING SERVICES; FOOD AND BEVERAGE PREPARATION SERVICES; OFFICE AND INSTITUTIONAL COFFEE SUPPLY SERVICES FOR IMMEDIATE CONSUMPTION (U.S. CLS. 100 AND 101).

KAREN SEVERSON, EXAMINING ATTORNEY

SN 79-098,207. KONINKLIJKE PHILIPS ELECTRONICS N.V., NETHERLANDS, FILED 4-27-2011.

SURESUITE

THE MARK CONSISTS OF STANDARD CHARACTERS WITHOUT CLAIM TO ANY PARTICULAR FONT, STYLE, SIZE, OR COLOR.

PRIORITY DATE OF 11-1-2010 IS CLAIMED.

OWNER OF INTERNATIONAL REGISTRATION 1079542 DATED 4-27-2011, EXPIRES 4-27-2021.

CLASS 9—ELECTRICAL AND SCIENTIFIC APPARATUS

FOR SOFTWARE FOR MEDICAL APPLICATIONS, NAMELY, SOFTWARE FOR USE IN CONNECTION WITH THE IMPLANTATION OF AND USE IN CONTROLLING NEUROSTIMULATION PULSE GENERATORS AND PROBES FOR NEUROSTIMULATION (U.S. CLS. 21, 23, 26, 36 AND 38).

CLASS 10—MEDICAL APPARATUS

FOR SURGICAL AND MEDICAL APPARATUS AND INSTRUMENTS, NAMELY, IMPLANTABLE NEUROSTIMULATION PULSE GENERATORS AND PROBES FOR NEUROSTIMULATION (U.S. CLS. 26, 39 AND 44).

CLASS 44—MEDICAL, BEAUTY AND AGRICULTURAL SERVICES

FOR MEDICAL SERVICES (U.S. CLS. 100 AND 101).
JANICE L. MCMORROW, EXAMINING ATTORNEY

SN 79-098,238. NIVOLA LIBROS Y EDICIONES, S.L., SPAIN, FILED 3-3-2011.

"NIVOLA"

THE MARK CONSISTS OF STANDARD CHARACTERS WITHOUT CLAIM TO ANY PARTICULAR FONT, STYLE, SIZE, OR COLOR.

OWNER OF INTERNATIONAL REGISTRATION 1079618 DATED 3-3-2011, EXPIRES 3-3-2021.

CLASS 16—PAPER GOODS AND PRINTED MATTER

FOR BOOK BINDING MATERIALS; FICTION AND NON-FICTION BOOKS, MAGAZINES AND PUBLICATIONS ON A VARIETY OF TOPICS; PRINTED INSTRUCTIONAL AND TEACHING MATERIALS ON A VARIETY OF SUBJECTS (U.S. CLS. 2, 5, 22, 23, 29, 37, 38 AND 50).

CLASS 41—EDUCATION AND ENTERTAINMENT

FOR PUBLICATION OF TEXTS, BOOKS AND NEWSPAPERS (U.S. CLS. 100, 101 AND 107).

ELI HELLMAN, EXAMINING ATTORNEY

SN 79-098,256. JGMK TRADEMARK FOR FASHION B.V., NETHERLANDS, FILED 4-28-2011.

CIRCLE OF GENTLEMEN

THE MARK CONSISTS OF STANDARD CHARACTERS WITHOUT CLAIM TO ANY PARTICULAR FONT, STYLE, SIZE, OR COLOR.

OWNER OF INTERNATIONAL REGISTRATION 1079653 DATED 4-28-2011, EXPIRES 4-28-2021.

CLASS 14—JEWELRY

FOR CUFF LINKS, TIE PINS, ORNAMENTS, NAMELY, JEWELRY (U.S. CLS. 2, 27, 28 AND 50).

CLASS 18—LEATHER GOODS

FOR BELTS OF LEATHER, LEATHER AND IMITATION LEATHER BAGS, GARMENT BAGS FOR TRAVEL MADE OF LEATHER AND IMITATIONS OF LEATHER; WALLETS MADE OF LEATHER AND IMITATIONS OF LEATHER; UMBRELLAS (U.S. CLS. 1, 2, 3, 22 AND 41).

CLASS 25—CLOTHING

FOR CLOTHING, NAMELY, SHIRTS, T-SHIRTS, SWEATSHIRTS, JUMPERS, JERSEYS, PANTS, JEANS, TROUSERS, JACKETS, SUIT-JACKETS, COATS, SHAWLS, SCARVES, TIES, SOCKS AND GLOVES AND FOOTWEAR, HEADGEAR, NAMELY, HATS AND CAPS (U.S. CLS. 22 AND 39).

BERYL GARDNER, EXAMINING ATTORNEY

SN 79-098,272. ENEL S.P.A., ITALY, FILED 4-14-2011.



PRIORITY DATE OF 4-1-2011 IS CLAIMED.
OWNER OF INTERNATIONAL REGISTRATION 1079687
DATED 4-14-2011, EXPIRES 4-14-2021.

OWNER OF U.S. REG. NOS. 2,705,661, 3,850,200 AND OTHERS.

NO CLAIM IS MADE TO THE EXCLUSIVE RIGHT TO USE "CO2 NEUTRAL", APART FROM THE MARK AS SHOWN.

THE COLOR(S) BLUE, ORANGE AND WHITE IS/ARE CLAIMED AS A FEATURE OF THE MARK.

THE MARK CONSISTS OF THE WHITE LETTERS AND NUMBER "CO2" WITH THE NUMBER "2" WRITTEN IN SUBSCRIPT, UNDER "CO2" APPEARS THE WHITE WORD "NEUTRAL", WITH "CO2" AND "NEUTRAL" BOTH INSIDE A SQUARE IN BLUE COLOR THAT IS MORE NUANCED AND CLEAR AFTER THE LETTER AND NUMBER "O2"; BELOW THE BLUE SQUARE THERE IS THE EXPRESSION, IN BLUE COLOR, "BETTER LIFE ON THE PLANET" IN STANDARD LETTERING, WITH THE LETTER "B" IN STANDARD UPPERCASE CHARACTER; BELOW, THE WORD "ENEL", WRITTEN IN STANDARD CHARACTERS IN BLUE COLOR, WITH THE LETTER "E" IN UPPERCASE AND ON THE LEFT A STYLIZED TREE IN ORANGE COLOR; ALL OF THE ABOVE DESCRIBED ELEMENTS ARE INSIDE A WHITE RECTANGLE WITH A BLUE BORDER.

CLASS 9—ELECTRICAL AND SCIENTIFIC APPARATUS

FOR SCIENTIFIC, NAUTICAL, SURVEYING, PHOTOGRAPHIC, CINEMATOGRAPHIC, OPTICAL, WEIGHING, MEASURING, SIGNALLING, CHECKING, SUPERVISION, LIFE-SAVING AND TEACHING APPARATUS AND INSTRUMENTS, NAMELY, APPARATUS TO MEASURE AND ANALYZE CO2 EMISSIONS, COMPUTER SOFTWARE TO MEASURE AND ANALYZE CO2 EMISSIONS; APPARATUS AND INSTRUMENTS FOR CONDUCTING, SWITCHING, TRANSFORMING, ACCUMULATING, REGULATING OR CONTROLLING ELECTRICITY, NAMELY, HYDRO-ELECTRIC GENERATION SYSTEMS COMPRISED PRIMARILY OF POWER TRANSMISSION LINES AND ELECTRICITY CONDUITS AND CONDENSERS, AND ALSO COMPRISING PUMPS FOR GENERATING ELECTRICITY, WIND ENERGY TURBINES, AND ELECTRICAL GENERATORS, SOLD AS A UNIT; MATERIAL FOR ELECTRICITY MAINS, NAMELY, ELECTRICAL WIRES, INSULATED ELECTRIC WIRES; ELECTRICAL NETWORK APPARATUS CONSISTING OF REMOTE CONTROL AND COMPUTER DISC DRIVING APPARATUS OF ELECTRICAL PLANTS; ELECTRICAL TRANSMISSION SUBSTATIONS, NAMELY, ELECTRICAL PLANTS COMPRISING TRANSFORMERS, DISCONNECTION CIRCUIT BREAKERS AND OTHER ELECTRICAL CONTROL APPARATUS FOR OPERATING THE ELECTRICAL ENERGY TRANSMISSION FROM THE PRODUCTION PLANTS TO THE DISTRIBUTION PLANTS; BREAKERS, NAMELY, CIRCUIT BREAKERS, DISCONNECTION ELECTRICAL LINE BREAKERS; ELECTRIC CONTROL PANELS FOR CONTROLLING THE VARIOUS ON/OFF STEPS OF THE ELECTRICAL PLANTS AND THE RIGHT CIRCUITRY FUNCTIONING; APPARATUS FOR RECORDING, TRANSMISSION OR REPRODUCTION OF SOUND OR IMAGES; MAGNETIC DATA CARRIERS, NAMELY, MAGNETIC CARDS BEING BLANK RECORD DISCS AND PRE-RECORDED RECORD DISCS IN THE FIELD OF MEASUREMENT AND ANALYSIS OF CO2 EMISSIONS (U.S. CLS. 21, 23, 26, 36 AND 38).

CLASS 11—ENVIRONMENTAL CONTROL APPARATUS

FOR APPARATUS FOR LIGHTING, HEATING, STEAM GENERATING, COOKING, REFRIGERATING, DRYING, VENTILATING, WATER SUPPLY AND SANITARY PURPOSES, NAMELY, LIGHTING INSTALLATIONS, HEATING INSTALLATIONS, STEAM GENERATING SYSTEM, APPARATUS AND INSTRUMENTS FOR LIGHTING MONUMENTS, HISTORICAL MONUMENTS AND PLACES OF AMUSEMENT, NAMELY, LIGHT PROJECTORS, LAMPS (U.S. CLS. 13, 21, 23, 31 AND 34).

CLASS 16—PAPER GOODS AND PRINTED MATTER

FOR PAPER, CARDBOARD AND GOODS MADE FROM THESE MATERIALS, NOT INCLUDED IN OTHER CLASSES, NAMELY, PAPER AND CARDBOARD BOXES, PAPER AND CARDBOARD PLAY CARDS, STORAGE CONTAINERS OF PAPER AND CARDBOARD IN THE FIELD OF MEASUREMENT AND ANALYSIS OF CO2 EMISSIONS; BOOKBINDING MATERIAL; PHOTOGRAPHS; STATIONERY; ADHESIVES FOR STATIONERY OR HOUSEHOLD PURPOSES; PRINTERS' TYPE; PRINTING BLOCKS (U.S. CLS. 2, 5, 22, 23, 29, 37, 38 AND 50).

CLASS 35—ADVERTISING AND BUSINESS

FOR ADVERTISING; BUSINESS MANAGEMENT; BUSINESS ADMINISTRATION; PROVIDING OFFICE FUNCTIONS (U.S. CLS. 100, 101 AND 102).

CLASS 36—INSURANCE AND FINANCIAL

FOR INSURANCE, NAMELY, INSURANCE CONSULTATION SERVICES IN THE FIELD OF CO2 EMISSIONS; FINANCIAL AFFAIRS, NAMELY, FINANCIAL ANALYSIS AND CONSULTATION (U.S. CLS. 100, 101 AND 102).

CLASS 38—COMMUNICATION

FOR TELECOMMUNICATIONS, NAMELY, TRANSFER OF DATA BY TELECOMMUNICATION, PROVIDING INFORMATION ABOUT TELECOMMUNICATIONS IN THE FORM OF ELECTRONIC NEWSLETTERS, TELECOMMUNICATIONS CONSULTATION SERVICES VIA INTERNET IN THE FIELD OF REDUCTION OF CO2 EMISSIONS (U.S. CLS. 100, 101 AND 104).

CLASS 39—TRANSPORTATION AND STORAGE

FOR ELECTRIC ENERGY DISTRIBUTION (U.S. CLS. 100 AND 105).

CLASS 40—MATERIAL TREATMENT

FOR TREATMENT OF MATERIALS, NAMELY, GENERATION OF GAS AND ELECTRICITY (U.S. CLS. 100, 103 AND 106).

CLASS 41—EDUCATION AND ENTERTAINMENT

FOR EDUCATION SERVICES, NAMELY, PROVIDING CLASSES, WORKSHOPS, SEMINARS IN THE FIELD OF ANALYSIS, MEASUREMENT AND REDUCTION OF CO2 EMISSIONS; PROVIDING OF TRAINING IN THE FIELD OF ANALYSIS, MEASUREMENT AND REDUCTION OF CO2 EMISSIONS (U.S. CLS. 100, 101 AND 107).

CLASS 42—SCIENTIFIC AND COMPUTER SERVICES

FOR SCIENTIFIC AND TECHNOLOGICAL SERVICES, NAMELY, SCIENTIFIC RESEARCH, SCIENTIFIC ANALYSIS, SCIENTIFIC TESTING IN THE FIELD OF REDUCTION OF CO2 EMISSIONS AND RESEARCH AND DESIGN RELATING THERETO; INDUSTRIAL ANALYSIS AND RESEARCH SERVICES IN THE FIELD OF REDUCTION OF CO2 EMISSIONS; DESIGN AND DEVELOPMENT OF COMPUTER HARDWARE AND SOFTWARE (U.S. CLS. 100 AND 101).

KRISTIN CARLSON, EXAMINING ATTORNEY

SN 79-098,590. OHBABY LIMITED, NEW ZEALAND, FILED 5-17-2011.

OHbaby!

THE MARK CONSISTS OF STANDARD CHARACTERS WITHOUT CLAIM TO ANY PARTICULAR FONT, STYLE, SIZE, OR COLOR.

OWNER OF INTERNATIONAL REGISTRATION 1080474 DATED 5-17-2011, EXPIRES 5-17-2021.

CLASS 9—ELECTRICAL AND SCIENTIFIC APPARATUS

FOR ELECTRONIC PUBLICATIONS, NAMELY, MAGAZINES DOWNLOADED OVER THE INTERNET FEATURING INFORMATION AND ADVICE RELATING TO PREGNANCY, BIRTH, INFANTS, CHILDREN, MOTHERS AND FAMILIES (U.S. CLS. 21, 23, 26, 36 AND 38).

CLASS 16—PAPER GOODS AND PRINTED MATTER

FOR CHILDREN'S MAGAZINES; COVERS FOR BIRTH, PREGNANCY, CHILDREN, MOTHERS AND FAMILY GENERAL INTEREST MAGAZINES; MAGAZINES AS GENERAL INTEREST PERIODICALS FOR WOMEN AND FAMILIES; PERIODICAL MAGAZINES FEATURING INFORMATION AND ADVICE RELATING TO BIRTH, PREGNANCY, CHILDREN, MOTHERS AND FAMILIES (U.S. CLS. 2, 5, 22, 23, 29, 37, 38 AND 50).

WILLIAM ROSSMAN, EXAMINING ATTORNEY

SN 79-098,613. CORPORACIÓN INDUSTRIAL Z-MOBILE, S.L., SPAIN, FILED 3-23-2011.

VICTOR&VICENTE

THE MARK CONSISTS OF STANDARD CHARACTERS WITHOUT CLAIM TO ANY PARTICULAR FONT, STYLE, SIZE, OR COLOR.

PRIORITY DATE OF 10-11-2010 IS CLAIMED.

OWNER OF INTERNATIONAL REGISTRATION 1080549 DATED 3-23-2011, EXPIRES 3-23-2021.

THE NAMES SHOWN IN THE MARK DO NOT IDENTIFY PARTICULAR LIVING INDIVIDUALS.

CLASS 12—VEHICLES

FOR MOTORS AND ENGINES FOR LAND VEHICLES; INTERNAL COMBUSTION MOTORS AND ENGINES FOR LAND VEHICLES; ACCESSORIES FOR MOTORS AND ENGINES INCLUDED IN THIS CLASS, NAMELY, GEARBOXES FOR LAND VEHICLES; MOTORS AND ENGINE BLOCKS FOR LAND VEHICLES; ALL-TERRAIN VEHICLES, LAND VEHICLES; APPARATUS FOR LOCOMOTION BY LAND, AND PARTICULARLY, ELECTRIC VEHICLES (U.S. CLS. 19, 21, 23, 31, 35 AND 44).

CLASS 35—ADVERTISING AND BUSINESS

FOR WHOLESALE AND RETAIL STORE SERVICES FEATURING VEHICLES AND THE PARTS AND ACCESSORIES THEREOF; ADVERTISING SERVICES; IMPORT AND EXPORT AGENCIES IN THE FIELD OF VEHICLES IN GENERAL (U.S. CLS. 100, 101 AND 102).

CLASS 37—CONSTRUCTION AND REPAIR

FOR VEHICLE SERVICE STATIONS; SERVICES FOR THE PAINTING, POLISHING, REPAIR, GREASING, WASHING AND CLEANING OF VEHICLES AND TIRE REPAIR SERVICES (U.S. CLS. 100, 103 AND 106).

TINA BROWN, EXAMINING ATTORNEY

SN 79-098,755. ZAMIR TELECOM LIMITED, UNITED KINGDOM, FILED 1-28-2011.



OWNER OF INTERNATIONAL REGISTRATION 1080968 DATED 1-28-2011, EXPIRES 1-28-2021.

NO CLAIM IS MADE TO THE EXCLUSIVE RIGHT TO USE "CALL", APART FROM THE MARK AS SHOWN.

THE COLOR(S) NAVY BLUE, LIGHT BLUE, ORANGE AND WHITE IS/ARE CLAIMED AS A FEATURE OF THE MARK.

THE MARK CONSISTS OF THE WORDING "SIMPLE CALL" AND A DESIGN OF A TELEPHONE SUBSTITUTED FOR THE LETTER "I". THE WORDING "CALL" IS LIGHT BLUE, THE LETTERS "S", "M", "P", "L", "E" ARE NAVY BLUE, THE TELEPHONE IS ORANGE WITH A WHITE SCREEN AND WHITE BUTTONS AND OUTLINED IN NAVY BLUE AND WITH FOUR NAVY BLUE SEMI-CIRCLES ABOVE IT.

CLASS 35—ADVERTISING AND BUSINESS

FOR BUSINESS MANAGEMENT OF TELECOMMUNICATIONS NETWORKS FOR OTHERS, NAMELY, THE OPERATION AND ADMINISTRATION OF TELECOMMUNICATION AND COMPUTER SYSTEMS AND NETWORKS FOR OTHERS; BUSINESS MANAGEMENT OF COMPUTER NETWORKS FOR OTHERS; BUSINESS INFORMATION SERVICES, NAMELY, PROVIDING BUSINESS ADVICE AND INFORMATION; ADVERTISING, MARKETING AND PUBLICITY SERVICES; PROVISION OF SPACE ON WEBSITES FOR ADVERTISING GOODS AND SERVICES; BUSINESS CONSULTING SERVICES RELATING TO TELECOMMUNICATIONS NETWORKS, COMPUTER NETWORKS AND BUSINESS OPERATIONS; TELEMARKETING; ANALYSIS AND RETRIEVAL OF INFORMATION, NAMELY, PROVIDING INFORMATION AND ANALYSIS IN THE FIELD OF BUSINESS; PROVIDING BUSINESS CONSULTANCY, ADVICE AND INFORMATION (U.S. CLS. 100, 101 AND 102).

CLASS 38—COMMUNICATION

FOR TELECOMMUNICATIONS SERVICES, NAMELY, TELECOMMUNICATION ACCESS SERVICES, PROVIDING INTERNET ACCESS, PROVIDING ACCESS TO DATABASES, AND PROVIDING ON-LINE COMMUNICATIONS LINKS WHICH TRANSFER THE WEBSITE USER TO OTHER LOCAL AND GLOBAL WEB PAGES; TRANSMISSION OF DATABASE INFORMATION VIA TELECOMMUNICATIONS NETWORKS; BROADCASTING SERVICES, NAMELY, RADIO AND TELEVISION BROADCASTING; ELECTRONIC TRANSMISSION OF DATA, SOUND OR IMAGES BY TELEVISION AND VIDEO BROADCASTING; SATELLITE COMMUNICATION SERVICES; COMMUNICATIONS VIA TELEVISION AND RADIO TRANSMISSIONS; RENTAL AND LEASING OF COMMUNICATIONS APPARATUS; ELECTRONIC MAIL SERVICES; PROVISION OF ON-LINE COMMUNICATIONS LINKS WHICH TRANSFER THE USER TO OTHER LOCAL AND GLOBAL WEB PAGES; PROVIDING USER ACCESS TO THE INTERNET; PROVIDING TELECOMMUNICATION CONNECTIVITY SERVICES FOR THE TRANSFER OF MULTIMEDIA WORKS; DIGITAL BROADCASTING SERVICES, NAMELY, TRANSMISSION OF VOICE, DATA AND IMAGES VIA DIGITAL COMMUNICATIONS NETWORKS ELECTRONIC BULLETIN BOARD SERVICES; TRANSMISSION OF NEWS; INTERNET PORTAL SERVICES, NAMELY, TELECOMMUNICATIONS GATEWAY SERVICES; TELECOMMUNICATIONS CONSULTATION (U.S. CLS. 100, 101 AND 104).

JOHN DWYER, EXAMINING ATTORNEY

SN 79-098,758. S.N.R. ROULEMENTS, FRANCE, FILED 12-29-2010.



PRIORITY DATE OF 7-5-2010 IS CLAIMED.
OWNER OF INTERNATIONAL REGISTRATION 1080974 DATED 12-29-2010, EXPIRES 12-29-2020.
OWNER OF U.S. REG. NOS. 876,459 AND 891,535.
THE COLOR(S) BLUE AND YELLOW IS/ARE CLAIMED AS A FEATURE OF THE MARK.

THE MARK CONSISTS OF THE STYLIZED WORDING "NTN SNR" IN BLUE, WITH "SNR" INSIDE A YELLOW OVAL WHICH IN TURN IS WITHIN A BLUE RECTANGLE; THE COLOR WHITE REPRESENTS BACKGROUNDS, OUTLINING, SHADING AND/OR TRANSPARENT AREAS AND IS NOT PART OF THE MARK.

CLASS 7—MACHINERY

FOR MACHINES FOR MANUFACTURING BEARINGS; METALWORKING MACHINE TOOLS; COMPONENT MACHINE PARTS OF THESE MACHINES, NAMELY, BALL BEARINGS, ROLLER BEARINGS, THRUST BEARINGS, SMOOTH RINGS OR PLAIN BEARINGS, BALL CAGES, ROLLER CAGES OR NEEDLE ROLLER CAGES, BEARINGS FOR TRANSMISSION SHAFTS OTHER THAN FOR LAND VEHICLES; BEARINGS AS PART OF MACHINES; CRANES AS LIFTING AND HOISTING APPARATUS; WIND TURBINES; HYDRAULIC PILE EXTRACTORS; AGRICULTURAL MACHINES, NAMELY, REAPERS, DISK HARROWS, SEEDERS, CULTIPACKERS; LARGE AGRICULTURAL IMPLEMENTS AND COMPONENT PARTS OF THESE IMPLEMENTS, NAMELY, CULTIVATORS, HARVESTERS, INCORPORATORS, SEED DRILLS, HAY BALERS, COULTERS (U.S. CLS. 13, 19, 21, 23, 31, 34 AND 35).

CLASS 9—ELECTRICAL AND SCIENTIFIC APPARATUS

FOR SCIENTIFIC APPARATUS AND INSTRUMENTS, NAMELY, TESTING EQUIPMENT FOR MEASURING THE TEMPERATURE, WEIGHT, SPEED, PRESSURE, POSITION OR FORM OF WORKPIECES IN A MACHINE TOOL; ELECTRIC APPARATUS AND INSTRUMENTS, NAMELY, TESTING EQUIPMENT FOR MEASURING THE TEMPERATURE, WEIGHT, SPEED, PRESSURE, POSITION OR FORM OF WORKPIECES IN A MACHINE TOOL; OPTICAL APPARATUS AND INSTRUMENTS, NAMELY, TESTING EQUIPMENT FOR MEASURING THE TEMPERATURE, WEIGHT, SPEED, PRESSURE, POSITION OR FORM OF WORKPIECES IN A MACHINE TOOL; SCIENTIFIC APPARATUS, NAMELY, SENSING AND SIGNALING DEVICES FOR MEASUREMENT AND QUALITY CONTROL OF MATERIALS PROCESSING IN CONNECTION WITH ROLLING BEARINGS, THRUST BEARINGS, TRANSMISSION SHAFTS, BEARINGS AND COMPONENT PARTS OF MACHINES, MACHINE TOOLS AND LAND, AIR, SEA AND SPACE VEHICLES; DATA PROCESSORS AND COMPUTERS; COMPUTER SOFTWARE FOR MAINTAINING AND MONITORING MACHINES, ESPECIALLY FOR DATA MANAGEMENT; COMPUTER SOFTWARE, CD-ROMS, DVD-ROMS FOR TRAINING ON THE USE OF TECHNOLOGY AND PRODUCTS, NAMELY, ROLLING BEARINGS, THRUST BEARINGS, TRANSMISSION SHAFTS, BEARINGS AND COMPONENT PARTS OF MACHINES, MACHINE TOOLS AND LAND, AIR, SEA AND SPACE VEHICLES; GLOVES FOR PROTECTION AGAINST ACCIDENT; LASER THERMOMETERS, NOT FOR MEDICAL PURPOSES (U.S. CLS. 21, 23, 26, 36 AND 38).

CLASS 12—VEHICLES

FOR LAND VEHICLES, NAMELY, AUTOMOBILES, BUSES, TRUCKS, VANS, TRACTORS, LIFT TRUCKS AND TRAINS; AIR VEHICLES, NAMELY, AEROPLANES, AND SEAPLANES; SPACE VEHICLES; SEA VEHICLES, NAMELY, BOATS, CANOES, HYDROPLANES, SHIPS; COMPONENT PARTS OF THE AFOREMENTIONED LAND VEHICLES, NAMELY, TRANSMISSION SHAFTS (U.S. CLS. 19, 21, 23, 31, 35 AND 44).

JOHN DWYER, EXAMINING ATTORNEY

SN 79-098,761. DEALMARKET AG, SWITZERLAND, FILED 4-6-2011.

DEAL:MARKET

PRIORITY DATE OF 10-21-2010 IS CLAIMED.
OWNER OF INTERNATIONAL REGISTRATION 1080989
DATED 4-6-2011, EXPIRES 4-6-2021.

THE MARK CONSISTS OF THE WORDING "DEALMARKET" IN WHICH THE LETTER "M" IS BROKEN AND FORMED BY TWO SQUARES IN THE MIDDLE.

CLASS 35—ADVERTISING AND BUSINESS

FOR ADVERTISING AND MARKETING SERVICES; CONDUCTING, ARRANGING AND ORGANIZING TRADE SHOWS AND TRADE FAIRS FOR COMMERCIAL AND ADVERTISING PURPOSES; DISSEMINATION OF ADVERTISING MATTER; RENTAL OF ADVERTISING SPACE; SALES PROMOTION FOR OTHERS; SERVICES IN CONNECTION WITH A DATABASE, NAMELY, COMPILATION, ORGANIZATION AND SYSTEMATIZATION OF DATA; COMPILATION AND SYSTEMATIZATION OF DATA INTO COMPUTER DATABASES; PROVIDING INFORMATION, IN PARTICULAR ONLINE INFORMATION VIA A GLOBAL COMPUTER NETWORK, CONCERNING BUSINESS INFORMATION, BUSINESS TRANSACTIONS, THE PURCHASE AND SALE OF ENTERPRISES AND INVESTMENT POSSIBILITIES; COMPUTER FILE MANAGEMENT; BUSINESS MANAGEMENT SERVICES; BUSINESS MANAGEMENT AND ORGANIZATION CONSULTANCY; PROFESSIONAL BUSINESS CONSULTANCY; BUSINESS ADMINISTRATION; COMMERCIAL INFORMATION AGENCIES; BUSINESS RESEARCH UND INVESTIGATIONS; BUSINESS INFORMATION; BUSINESS APPRAISALS; AUCTIONEERING (U.S. CLS. 100, 101 AND 102).

CLASS 36—INSURANCE AND FINANCIAL

FOR FINANCIAL ANALYSES, NAMELY, OR PRIMARILY THIRD PARTY RELATED; CAPITAL INVESTMENTS SERVICES, NAMELY, OR PRIMARILY THIRD PARTY DRIVEN; FINANCIAL SERVICES, NAMELY, PROVIDING AN INTERNET WEBSITE PORTAL OFFERING INVESTMENT OPPORTUNITIES AND INFORMATION IN THE FIELDS OF FINANCE, PRIVATE EQUITY AND FINANCIAL INVESTMENTS; PROVIDING INFORMATION RELATED TO FINANCIAL INVESTMENTS AND OPPORTUNITIES VIA THE INTERNET; ONLINE FINANCIAL PLANNING SERVICES; ON-LINE TRADING OF FINANCIAL INSTRUMENTS, SHARES, OPTIONS AND OTHER DERIVATIVE PRODUCTS; REAL ESTATE SERVICES, NAMELY, PROVIDING INVESTMENT AND FINANCIAL INFORMATION AND OPPORTUNITIES WITHIN THE REAL ESTATE SECTOR (U.S. CLS. 100, 101 AND 102).

CLASS 38—COMMUNICATION

FOR ELECTRONIC BULLETIN BOARD SERVICES; PROVIDING ACCESS AND RENTAL OF ACCESS TIME TO GLOBAL COMPUTER NETWORKS FOR ELECTRONIC BUSINESS CONNECTIONS; RENTAL OF ACCESS TIME TO GLOBAL COMPUTER NETWORKS; PROVIDING ACCESS TO THE INTERNET; PROVIDING ACCESS TO GLOBAL COMPUTER NETWORKS; PROVIDING ACCESS TO ELECTRONIC DATABASES; PROVIDING INTERNET CHAT ROOMS; COMPILATION AND HANDLING OF DATA AND INFORMATION VIA GLOBAL COMPUTER NETWORKS; HANDLING OF FINANCIAL DATA AND FINANCIAL INFORMATION; PROVIDING ACCESS TO CUSTOMER DATABASES; PROVIDING FINANCIAL DATA CONTENT CALLABLE FROM THE INTERNET; PROVIDING ACCESS TO FINANCIAL INFORMATION FROM INTERNET DATABASES; TRANSMISSION OF CUSTOMER DATA AND INFORMATION ABOUT GLOBAL COMPUTER NETWORKS; FINANCIAL SERVICES IN CONNECTION WITH A DATABASE CONTAINING INVESTMENTS AND OPPORTUNITIES, NAMELY, RECEIPT OF ALL KIND OF MESSAGES OF DATABASE USERS AND FORWARDING TO OTHER DATABASE USERS; PROVIDING INTERNET PLATFORMS CONTAINING INVESTMENTS, MARKETING AND ADVERTISING OPPORTUNITIES (U.S. CLS. 100, 101 AND 104).

RAMONA ORTIGA, EXAMINING ATTORNEY

SN 79-098,803. PAPER C GMBH, FED REP GERMANY, FILED 1-18-2011.

PaperC

THE MARK CONSISTS OF STANDARD CHARACTERS WITHOUT CLAIM TO ANY PARTICULAR FONT, STYLE, SIZE, OR COLOR.

OWNER OF INTERNATIONAL REGISTRATION 1081097
DATED 1-18-2011, EXPIRES 1-18-2021.

CLASS 9—ELECTRICAL AND SCIENTIFIC APPARATUS

FOR MACHINE-READABLE DATA RECORDING CARRIER, NAMELY, BLANK MAGNETIC, ELECTRICAL AND OPTICAL DATA CARRIERS FOR RECORDING, REPRODUCTION, TRANSMISSION AND PROCESSING OF IMAGES AND DATA; BLANK TAPES FOR STORAGE OF COMPUTER DATA; DOWNLOADABLE COMPUTER SOFTWARE IN THE FIELD OF LITERATURE FOR USE IN THE QUERY, DISPLAY, EDITING, AND RELEASE OF MULTI-MEDIA BASED DATA IN COMPUTER NETWORKS SUCH AS THE INTERNET AND MOBILE ELECTRONIC DEVICES; DOWNLOADABLE ELECTRONIC PUBLICATIONS IN THE NATURE OF BOOKS IN THE FIELD OF SCIENCE AND MATH (U.S. CLS. 21, 23, 26, 36 AND 38).

CLASS 16—PAPER GOODS AND PRINTED MATTER

FOR PRINTED MATTER, NAMELY, BOOKS, JOURNALS AND TEXTBOOKS IN THE FIELD OF SCIENCE AND ENGLISH LITERATURE (U.S. CLS. 2, 5, 22, 23, 29, 37, 38 AND 50).

CLASS 35—ADVERTISING AND BUSINESS

FOR ADVERTISING, IN PARTICULAR ONLINE ADVERTISING IN A COMPUTER NETWORK, ADVERTISING THROUGH PRINT MEDIA AND VIA THE INTERNET, ADVERTISING PROVIDED VIA MOBILE COMMUNICATIONS NETWORKS; LEASING OF ADVERTISING SPACE IN THE INTERNET; BUSINESS MARKETING FOR OTHERS THROUGH DIGITAL NETWORKS, ADVERTISING FOR OTHERS PROVIDED VIA THE INTERNET; ORGANIZATION OF FAIRS FOR PROFESSIONAL AND ADVERTISING PURPOSES; BUSINESS MANAGEMENT; SYSTEMATIZATION AND COMPILATION OF DATA AND INFORMATION IN COMPUTER DATABASES (U.S. CLS. 100, 101 AND 102).

CLASS 38—COMMUNICATION

FOR TELECOMMUNICATIONS, IN PARTICULAR TRANSMISSION OF DATA AND INFORMATION BY COMPUTER AND ELECTRONIC COMMUNICATION MEANS; PROVISION OF TELECOMMUNICATIONS CONNECTIONS TO DATA IN THE INTERNET AND MOBILE INTERNET; PROVISION OF TELECOMMUNICATIONS CONNECTIONS TO DATA IN COMPUTER NETWORKS, NAMELY, TO INFORMATION, TEXT, DRAWINGS AND IMAGES OF GOODS AND SERVICES; PROVIDING ACCESS TO PLATFORMS ON THE INTERNET AS WELL AS ON THE MOBILE INTERNET; PROVIDING ACCESS TO CHATROOMS AND COMMUNITY FORUMS ON THE INTERNET INCLUDING MOBILE INTERNET; BROADCASTING AND TRANSMISSION OF INFORMATION AND DATA VIA COMPUTER NETWORKS AND VIA THE INTERNET, ALSO THE MOBILE INTERNET; LEASING OF ACCESS TIME TO DATABASES AND PROVISION OF ACCESS TO DATABASES (U.S. CLS. 100, 101 AND 104).

CLASS 42—SCIENTIFIC AND COMPUTER SERVICES

FOR COMPUTER PROGRAMMING; DESIGN OF COMPUTER SOFTWARE; DESIGN OF HOME PAGES AND WEB PAGES; MAINTENANCE SERVICE AND INSTALLATION OF COMPUTER SOFTWARE; COMPUTER SERVICES, NAMELY, CREATING INDEXES OF INFORMATION SITES AND OTHER RESOURCES AVAILABLE ON COMPUTER NETWORKS (U.S. CLS. 100 AND 101).

CLASS 45—PERSONAL AND LEGAL SERVICES

FOR EXPLOITATION OF COPYRIGHTS AND INDUSTRIAL PROPERTY RIGHTS FOR OTHERS VIA GRANTING OF LICENSES (U.S. CLS. 100 AND 101).
VERNA BETH RIRIE, EXAMINING ATTORNEY

SN 79-098,852. KONINKLIJKE PHILIPS ELECTRONICS N.V., EINDHOVEN, NETHERLANDS, FILED 5-20-2011.

FREESTREET

THE MARK CONSISTS OF STANDARD CHARACTERS WITHOUT CLAIM TO ANY PARTICULAR FONT, STYLE, SIZE, OR COLOR.
PRIORITY DATE OF 11-22-2010 IS CLAIMED.
OWNER OF INTERNATIONAL REGISTRATION 1081263 DATED 5-20-2011, EXPIRES 5-20-2021.

CLASS 9—ELECTRICAL AND SCIENTIFIC APPARATUS

FOR ELECTRONIC CONTROL APPARATUS AND SOFTWARE FOR LIGHTING SYSTEMS, ELECTRONIC BALLASTS FOR LIGHTING PURPOSES; LIGHT EMITTING DIODES (LEDS), LASER DIODES AND ZENER DIODES; ELECTRONIC OPTICAL CONTROL APPARATUS AND ELECTRONIC THERMAL CONTROL APPARATUS FOR LIGHTING SYSTEMS, ELECTRIC CIRCUITS FOR LIGHTING CONTROL SYSTEMS AND LIGHTING MANAGEMENT SYSTEMS (U.S. CLS. 21, 23, 26, 36 AND 38).

CLASS 11—ENVIRONMENTAL CONTROL APPARATUS

FOR APPARATUS FOR LIGHTING, NAMELY, LIGHTING INSTALLATIONS, ELECTRIC LAMPS, LIGHTING FIXTURES AND LIGHTING INSTALLATIONS; SOLID STATE LIGHTING AND ELECTRONIC LIGHTING COMPONENTS, IN PARTICULAR LED MODULES IN WHOLE OR IN PART CONSISTING OF INTEGRATED LEDS, OLEDS, POLYMER EMITTING DIODES; AND PARTS OF THE AFORESAID GOODS SOLD TOGETHER AS A UNIT (U.S. CLS. 13, 21, 23, 31 AND 34).

JANICE L. MCMORROW, EXAMINING ATTORNEY

SN 79-098,855. STUDIO HAMBURG DOCLIGHTS GMBH, FED REP GERMANY, FILED 3-3-2011.

Doclights

THE MARK CONSISTS OF STANDARD CHARACTERS WITHOUT CLAIM TO ANY PARTICULAR FONT, STYLE, SIZE, OR COLOR.

PRIORITY DATE OF 9-6-2010 IS CLAIMED.
OWNER OF INTERNATIONAL REGISTRATION 1081266 DATED 3-3-2011, EXPIRES 3-3-2021.

CLASS 9—ELECTRICAL AND SCIENTIFIC APPARATUS

FOR PRERECORDED DVDS FEATURING MOTION PICTURES AND TELEVISION PROGRAMS FEATURING ACTION, ADVENTURE, COMEDY, DRAMA, ANIMATION, DOCUMENTARIES ABOUT HISTORY, NATURE, WILDLIFE, TECHNOLOGY, BUSINESS, FINANCE, ENVIRONMENTAL ISSUES, GEOGRAPHY, MUSIC, ART, CULTURE, EDUCATION, POLITICS AND ONGOING REALITY-BASED STORIES ABOUT THE EXPERIENCES OF PEOPLE; PRERECORDED CDS FEATURING MUSIC; CAMERAS, LENSES FOR CAMERAS, PHOTOGRAPHIC CAMERA STANDS, AND MICROPHONES, APPARATUS FOR RECORDING, TRANSMISSION AND REPRODUCTION OF SOUND AND/OR IMAGES (U.S. CLS. 21, 23, 26, 36 AND 38).

CLASS 35—ADVERTISING AND BUSINESS

FOR BUSINESS MANAGEMENT; ORGANIZATIONAL CONSULTANCY IN THE FIELD OF TELEVISION AND RADIO PROGRAMS; BUSINESS ORGANIZATIONAL CONSULTANCY IN THE FIELD OF DEVELOPMENT, DESIGN, PRODUCTION AND BROADCASTING OF FILMS (U.S. CLS. 100, 101 AND 102).

CLASS 38—COMMUNICATION

FOR BROADCASTING OF TELEVISION PROGRAMS AND TELEVISION AND AUDIO BROADCASTS ON THE INTERNET AND OTHER AUDIO-VISUAL MEDIA; SIMULCASTING BROADCAST TELEVISION OVER GLOBAL COMMUNICATION NETWORKS, THE INTERNET AND WIRELESS NETWORKS (U.S. CLS. 100, 101 AND 104).

CLASS 40—MATERIAL TREATMENT

FOR PROCESSING OF CINEMATOGRAPHIC FILMS (U.S. CLS. 100, 103 AND 106).

CLASS 41—EDUCATION AND ENTERTAINMENT

FOR FILM PRODUCTION; ELECTRONIC EDITING OF FILMS BY COMPUTER; MOTION PICTURE STUDIOS, IN PARTICULAR STUDIOS FOR TELEVISION AND VIDEO PRODUCTION; RECORDING STUDIO SERVICES; DUBBING; PUBLICATION OF TEXT, GRAPHICS, IMAGES AND SOUND DATA WHICH CAN BE TRANSMITTED ELECTRONICALLY AND IS ACCESSIBLE VIA DATA NETWORKS OTHER THAN FOR ADVERTISING PURPOSES; PUBLICATION OF PRINTED MATTER IN THE NATURE OF ADVENTURE, COMEDY, DRAMA, HISTORY, NATURE, TECHNOLOGY, BUSINESS, GEOGRAPHY, MUSIC, ART, EDUCATION, POLITICS OTHER THAN FOR ADVERTISING PURPOSES; DIGITAL IMAGING SERVICES (U.S. CLS. 100, 101 AND 107).

CLASS 45—PERSONAL AND LEGAL SERVICES

FOR FILM, TELEVISION AND VIDEO LICENSING; LICENSING OF BOOKS CONTAINING SCREENPLAYS; LICENSING OF INTELLECTUAL PROPERTY (U.S. CLS. 100 AND 101).

RAMONA ORTIGA, EXAMINING ATTORNEY

SN 79-099,033. FOTONA D.D., SLOVENIA, FILED 5-30-2011.

TWINLIGHT

THE MARK CONSISTS OF STANDARD CHARACTERS WITHOUT CLAIM TO ANY PARTICULAR FONT, STYLE, SIZE, OR COLOR.

PRIORITY DATE OF 3-2-2011 IS CLAIMED.
OWNER OF INTERNATIONAL REGISTRATION 1081731 DATED 5-30-2011, EXPIRES 5-30-2021.

CLASS 10—MEDICAL APPARATUS

FOR SURGICAL, MEDICAL, DENTAL AND VETERINARY APPARATUS AND INSTRUMENTS FOR USE IN DERMATOLOGY PROCEDURES AND SURGERY, PLASTIC SURGERY PROCEDURES, TREATMENT OF SKIN IMPERFECTIONS, PHOTOCOAGULATION AND HEMOSTASIS, AND ENDODONTIC, PERIODONTIC, AESTHETIC DENTISTRY AND SURGERY; LASERS FOR SURGICAL, MEDICAL, DENTAL AND VETERINARY PURPOSES AND THEIR PARTS AND ACCESSORIES BELONGING TO THIS CLASS; TWO-WAVELENGTH LASERS FOR SURGICAL, MEDICAL, DENTAL AND VETERINARY PURPOSES; PARTS AND ACCESSORIES FOR TWO-WAVELENGTH LASERS FOR SURGICAL, MEDICAL, DENTAL AND VETERINARY PURPOSES, NAMELY, LASER HANDPIECES, LASER SCANNERS; LASER SYSTEM FOR MEDICAL, COSMETIC, DERMATOLOGICAL AND ESTHETICAL PROCEDURES COMPRISING LASER HEAD AND POWER SUPPLY; LASERS FOR SKIN REJUVENATION FOR MEDICAL PURPOSES, AND FOR THE COSMETIC TREATMENT OF THE FACE AND SKIN (U.S. CLS. 26, 39 AND 44).

CLASS 44—MEDICAL, BEAUTY AND AGRICULTURAL SERVICES

FOR MEDICAL SERVICES; VETERINARY SERVICES; HYGIENIC AND BEAUTY CARE FOR HUMAN BEINGS OR ANIMALS; BEAUTY SALONS; MASSAGE; PLASTIC SURGERY; DERMATOLOGICAL SERVICES; LASER SKIN REJUVENATION; PROVIDING INFORMATION ON LASER SKIN REJUVENATION; MEDICAL CONSULTANCY RELATING TO LASER SKIN REJUVENATION (U.S. CLS. 100 AND 101).

DAVID TOOLEY, EXAMINING ATTORNEY

SN 79-099,037. SIGVARIS AG, SWITZERLAND, FILED 5-31-2011.

SENSINNOV

THE MARK CONSISTS OF STANDARD CHARACTERS WITHOUT CLAIM TO ANY PARTICULAR FONT, STYLE, SIZE, OR COLOR.

PRIORITY DATE OF 2-17-2011 IS CLAIMED.
OWNER OF INTERNATIONAL REGISTRATION 1081751 DATED 5-31-2011, EXPIRES 5-31-2021.
OWNER OF U.S. REG. NO. 3,964,695.

CLASS 10—MEDICAL APPARATUS

FOR GARTERS AND GRIP-TOP BANDS AS PARTS OF MEDICAL COMPRESSION AND MEDICAL SUPPORT STOCKINGS (U.S. CLS. 26, 39 AND 44).

CLASS 25—CLOTHING

FOR GARTERS AND GRIP-TOP BANDS AS PARTS OF STOCKINGS (U.S. CLS. 22 AND 39).

SEAN CROWLEY, EXAMINING ATTORNEY

SN 79-099,152. MIROGLIO TEXTILE S.R.L., ITALY, FILED 5-3-2011.



PRIORITY DATE OF 4-27-2011 IS CLAIMED.
OWNER OF INTERNATIONAL REGISTRATION 1082072 DATED 5-3-2011, EXPIRES 5-3-2021.

THE MARK CONSISTS OF THE WORDING "NEWLIFE" IN STYLIZED FONT. A BOTTLE WITH THE BOTTOM HALF BROKEN INTO FRAGMENTS, APPEARS TO THE LEFT OF THE WORDING. TWO STYLIZED ARROWS, COMPRISING A PORTION OF THE UNIVERSAL RECYCLING SYMBOL, APPEAR TO THE RIGHT OF THE WORDING. A SERIES OF BOTTLE FRAGMENTS, CIRCLES, AND CURVED BANDS APPEARS BENEATH THE WORDING AND CONNECTS THE BOTTLE WITH THE ARROWS.

CLASS 23—YARNS AND THREADS

FOR YARNS AND THREADS, FOR TEXTILE USE (U.S. CL. 43).

CLASS 24—FABRICS

FOR TEXTILES AND TEXTILE GOODS, NAMELY, FABRICS FOR TEXTILE USE, TEXTILE LABELS, TEXTILE TABLE CLOTHS, TEXTILE FABRICS FOR THE MANUFACTURE OF CLOTHING (U.S. CLS. 42 AND 50).
LIEF MARTIN, EXAMINING ATTORNEY

SN 79-099,252. SIEMENS AKTIENGESELLSCHAFT, FED REP GERMANY, FILED 1-11-2011.

BaggageCube

THE MARK CONSISTS OF STANDARD CHARACTERS WITHOUT CLAIM TO ANY PARTICULAR FONT, STYLE, SIZE, OR COLOR.

PRIORITY DATE OF 9-3-2010 IS CLAIMED.
OWNER OF INTERNATIONAL REGISTRATION 1082275 DATED 1-11-2011, EXPIRES 1-11-2021.

CLASS 7—MACHINERY

FOR MACHINES, APPARATUS AND ACCESSORIES FOR BAGGAGE CONVEYING AND BAGGAGE HANDLING INSTALLATIONS, NAMELY, BAGGAGE CONVEYOR MACHINERY AND BAGGAGE HANDLING MACHINES; MACHINES FOR DISTRIBUTING, SORTING AND POSITIONING OF BAGGAGE AND OTHER PIECE GOODS; MECHANICAL BAGGAGE AND PIECE GOOD HANDLING SYSTEMS COMPRISED OF ELECTRICAL, ELECTRONIC, PNEUMATIC OR HYDRAULIC ROLLER CONVEYORS, ACCUMULATING ROLLER CONVEYORS, CHAIN CONVEYORS, CONTINUOUS CONVEYORS, WHEEL CONVEYORS, LOADING AND UNLOADING BELTS, LIFTS, BALL ROLLER TABLES, ROLLER TABLES, WORK TABLES, POWERED BENDS, INCLINED FEEDS, TRANSVERSE ROLLER TABLES, ROLLER AND CHAIN LIFT TABLES, TRANSVERSE TRAVELLING CARS AND TRAVELLING TRUCKS, ROTARY TABLES, SWIVELLING TABLES, ROTARY PLATES, SWIVEL DEFLECTORS, DEFLECTORS, TWO-WAY BARRIERS, CHAIN PUSHERS, CHAIN DELIVERY UNITS, CHAIN TRANSFER UNITS, INCLINED EJECTORS, PARALLEL PUSHERS, LOADING MACHINERY, LIFTING MACHINERY, LOADING UNITS WITH LIFTING MACHINERY, REMOVAL MACHINERY, CONTAINER STACKING AND UNSTACKING MACHINERY, PALLET DOUBLERS, PALLET MAGAZINES, PROFILE CHECKING MACHINES; REPLACEMENT PARTS FOR THE AFORESAID APPARATUS (U.S. CLS. 13, 19, 21, 23, 31, 34 AND 35).

CLASS 9—ELECTRICAL AND SCIENTIFIC APPARATUS

FOR ELECTRIC, SIGNALLING, MEASURING, METERING, REGISTERING, MONITORING, CONTROLLING, REGULATING AND SWITCHING APPARATUS FOR BAGGAGE CONVEYING AND BAGGAGE HANDLING INSTALLATIONS; ELECTRIC APPARATUS FOR THE INPUT, PROCESSING, TRANSMISSION, STORAGE AND OUTPUT OF DATA, FOR BAGGAGE CONVEYING AND BAGGAGE HANDLING INSTALLATIONS; DATA-PROCESSING PROGRAMS (U.S. CLS. 21, 23, 26, 36 AND 38).

CLASS 42—SCIENTIFIC AND COMPUTER SERVICES

FOR DEVELOPMENT AND CREATION OF CUSTOMIZED BAGGAGE CONVEYING AND BAGGAGE HANDLING INSTALLATIONS; DESIGN AND DEVELOPMENT OF COMPUTER HARDWARE AND SOFTWARE FOR USE IN BAGGAGE CONVEYING AND BAGGAGE HANDLING INSTALLATIONS; INSTALLATION, UPDATING AND MAINTENANCE OF SOFTWARE IN BAGGAGE CONVEYING AND BAGGAGE HANDLING INSTALLATIONS (U.S. CLS. 100 AND 101).
MICHAEL ENGEL, EXAMINING ATTORNEY

SN 79-099,334. UMICORE AG & CO. KG, FED REP GERMANY, FILED 3-9-2011.

Rigilit

THE MARK CONSISTS OF STANDARD CHARACTERS WITHOUT CLAIM TO ANY PARTICULAR FONT, STYLE, SIZE, OR COLOR.

PRIORITY DATE OF 9-15-2010 IS CLAIMED.
OWNER OF INTERNATIONAL REGISTRATION 1082476 DATED 3-9-2011, EXPIRES 3-9-2021.

CLASS 14—JEWELRY

FOR PRECIOUS METALS AND THEIR ALLOYS, UNWROUGHT OR SEMI-WROUGHT; OXIDE DISPERSION STRENGTHENED PLATINUM OR ALLOYS OF PLATINUM FOR USE IN ASSEMBLY PARTS, COMPONENTS AND SYSTEMS FOR HIGH TEMPERATURE APPLICATIONS (U.S. CLS. 2, 27, 28 AND 50).

CLASS 40—MATERIAL TREATMENT

FOR TREATMENT OF MATERIALS, NAMELY, PRECIOUS METALS AND THEIR ALLOYS INCLUDING DISPERSION STRENGTHENED PLATINUM OR ALLOYS OF PLATINUM, RELATED TO CUSTOM PRODUCTION OF BUILDING ELEMENTS, COMPONENTS AND SYSTEMS FOR HIGH TEMPERATURE APPLICATIONS FOR OTHERS (U.S. CLS. 100, 103 AND 106).

CLASS 42—SCIENTIFIC AND COMPUTER SERVICES

FOR CONSULTANCY IN THE FIELD OF MANUFACTURING TECHNOLOGY (U.S. CLS. 100 AND 101).
PAUL MORENO, EXAMINING ATTORNEY

SN 79-099,344. DANISCO A/S, DENMARK, FILED 5-12-2011.

OSMOAID

THE MARK CONSISTS OF STANDARD CHARACTERS WITHOUT CLAIM TO ANY PARTICULAR FONT, STYLE, SIZE, OR COLOR.

OWNER OF INTERNATIONAL REGISTRATION 1082502 DATED 5-12-2011, EXPIRES 5-12-2021.

CLASS 1—CHEMICALS

FOR CHEMICALS USED IN INDUSTRY, NAMELY, SWEETENERS FOR USE IN THE PRODUCTION OF FOODSTUFFS, FOOD SUPPLEMENTS AND BEVERAGES (U.S. CLS. 1, 5, 6, 10, 26 AND 46).

CLASS 5—PHARMACEUTICALS

FOR SUGAR AND ARTIFICIAL SWEETENERS FOR MEDICAL PURPOSES; DIETETIC SUGAR AND ARTIFICIAL SWEETENERS FOR MEDICAL USE; LAXATIVES FOR MEDICAL USE (U.S. CLS. 6, 18, 44, 46, 51 AND 52).
KRISTINA MORRIS, EXAMINING ATTORNEY

SN 79-099,361. ALLERION B.V., NETHERLANDS, FILED 1-28-2011.

SN 79-099,371. VRIENS FOOD & COMPANY B.V., NETHERLANDS, FILED 3-21-2011.



PRIORITY DATE OF 9-17-2010 IS CLAIMED.
OWNER OF INTERNATIONAL REGISTRATION 1082536
DATED 1-28-2011, EXPIRES 1-28-2021.
THE MARK CONSISTS OF THE STYLIZED LETTERS "JR".

CLASS 9—ELECTRICAL AND SCIENTIFIC APPARATUS

FOR COMPUTER SOFTWARE FOR THE DESIGN, TAILORING AND MANUFACTURE OF FOOTWEAR, CLOTHING AND HATS; COMPUTER TERMINALS THAT ALLOW CONSUMERS TO DESIGN FOOTWEAR, CLOTHING AND HATS AND SUBMIT ORDERS FOR FOOTWEAR, CLOTHING AND HATS (U.S. CLS. 21, 23, 26, 36 AND 38).

CLASS 25—CLOTHING

FOR CLOTHING, NAMELY, FOOTWEAR AND HATS (U.S. CLS. 22 AND 39).

CLASS 35—ADVERTISING AND BUSINESS

FOR RETAIL STORE SERVICES FEATURING CLOTHING, FOOTWEAR AND HATS; BUSINESS INTERMEDIARY SERVICES IN THE FIELD OF SELLING CLOTHING, FOOTWEAR AND HATS; WHOLESALE DISTRIBUTORSHIPS FEATURING CLOTHING, FOOTWEAR AND HATS; IMPORT AND EXPORTS AGENCY SERVICES IN THE FIELD OF CLOTHING, FOOTWEAR AND HATS; ON-LINE RETAIL STORE SERVICES FEATURING CLOTHING, FOOTWEAR AND HATS (U.S. CLS. 100, 101 AND 102).

CLASS 42—SCIENTIFIC AND COMPUTER SERVICES

FOR DESIGN OF FOOTWEAR, CLOTHING AND HATS FOR OTHERS; TAILORED DESIGN OF FOOTWEAR, CLOTHING AND HATS FOR OTHERS; DRESS DESIGN SERVICES FOR OTHERS CONCERNING THE TAILORING AND MANUFACTURE OF FOOTWEAR, CLOTHING AND HATS; APPLICATION SERVICE PROVIDER (ASP) FEATURING SOFTWARE FOR USE IN THE DESIGN, TAILORING AND MANUFACTURE OF FOOTWEAR, CLOTHING AND HATS (U.S. CLS. 100 AND 101).

EDWARD NELSON, EXAMINING ATTORNEY



PRIORITY DATE OF 9-27-2010 IS CLAIMED.
OWNER OF INTERNATIONAL REGISTRATION 1082566
DATED 3-21-2011, EXPIRES 3-21-2021.

THE COLOR(S) PURPLE, WHITE, RED, YELLOW AND ORANGE IS/ARE CLAIMED AS A FEATURE OF THE MARK.

THE MARK CONSISTS OF THE WORD "ACTIVAID" ON A RECTANGULAR BACKGROUND. "ACTIVAID" IS IN PURPLE WITH A WHITE, RED, YELLOW AND ORANGE BACKGROUND.

CLASS 3—COSMETICS AND CLEANING PREPARATIONS

FOR SOAPS; PERFUMERY, ESSENTIAL OILS, COSMETICS, SKINCARE PRODUCTS, NAMELY, COSMETIC PRODUCTS IN THE FORM OF AEROSOLS FOR SKINCARE; NON-MEDICATED SKIN CARE PREPARATIONS, NAMELY, GELS, SPRAYS, LOTIONS AND CREAMS; GELS, SPRAYS, LOTIONS AND CREAMS FOR TOPICAL TREATMENT OF SKIN FOR COSMETIC PURPOSES; NON-MEDICATED TRANSDERMAL GEL, SPRAY, LOTION AND CREAM FOR TOPICAL TREATMENT OF SKIN FOR COSMETIC PURPOSE (U.S. CLS. 1, 4, 6, 50, 51 AND 52).

CLASS 5—PHARMACEUTICALS

FOR PHARMACEUTICAL PRODUCTS FOR THE TREATMENT OF FATIGUE; MEDICATED SKIN CARE PREPARATIONS, NAMELY, GELS, SPRAYS, LOTIONS AND CREAMS FOR MEDICAL AND/OR THERAPEUTIC PURPOSES; MEDICATED SKIN CARE PREPARATIONS, NAMELY, GELS, SPRAYS, LOTIONS AND CREAMS FOR TOPICAL TREATMENT OF SKIN FOR MEDICAL AND/OR THERAPEUTIC PURPOSES; MEDICATED SKIN CARE PREPARATIONS, NAMELY, GELS, SPRAYS, LOTIONS AND CREAMS WITH A TRANSDERMAL THERAPEUTIC EFFECT FOR MEDICAL AND/OR THERAPEUTIC USE (U.S. CLS. 6, 18, 44, 46, 51 AND 52).

CLASS 35—ADVERTISING AND BUSINESS

FOR RETAIL STORE SERVICES FEATURING COSMETIC PRODUCTS AND PHARMACEUTICAL PRODUCTS EXCLUDING RETAIL SERVICES IN RELATION TO THE SALE OF VETERINARY PRODUCTS; RETAIL STORE SERVICES FEATURING COSMETIC PRODUCTS AND PHARMACEUTICAL PRODUCTS THROUGH DIRECT SALES BY A NETWORK OF DISTRIBUTORS EXCEPT THE AFOREMENTIONED RETAIL SERVICES IN RELATION TO THE SALE OF VETERINARY PRODUCTS; DIRECT MARKETING SERVICES TO ASSIST OTHERS, NOT IN RELATION TO THE SALE OF VETERINARY PRODUCTS (U.S. CLS. 100, 101 AND 102).

PAUL MORENO, EXAMINING ATTORNEY

SN 79-099,422. EUROFEEDBACK, FRANCE, FILED 6-22-2011.

SN 79-099,502. PHILIP MACKEN, MANLY, AUSTRALIA, AND VIRGINIA MACKEN, MANLY, AUSTRALIA, FILED 2-4-2011.

INNATIS

THE MARK CONSISTS OF STANDARD CHARACTERS WITHOUT CLAIM TO ANY PARTICULAR FONT, STYLE, SIZE, OR COLOR.

PRIORITY DATE OF 12-27-2010 IS CLAIMED.

OWNER OF INTERNATIONAL REGISTRATION 1082703 DATED 6-22-2011, EXPIRES 6-22-2021.

THE WORDING "INNATIS" HAS NO MEANING IN A FOREIGN LANGUAGE.

PRIORITY DATE OF 8-5-2010 IS CLAIMED.

OWNER OF INTERNATIONAL REGISTRATION 1082933 DATED 2-4-2011, EXPIRES 2-4-2021.

THE MARK CONSISTS OF THE WORD "SURFIVAL" IN A STYLIZED FONT WITH THE "F" FORMED BY A CROSS DESIGN SUPERIMPOSED OVER CURVING LINES.

CLASS 3—COSMETICS AND CLEANING PREPARATIONS

FOR COSMETICS; NON-MEDICATED CREAMS, MILKS, LOTIONS, GELS AND POWDERS FOR THE FACE, BODY AND HANDS; COSMETIC CREAMS, COSMETIC LOTIONS, MOISTURIZING CREAMS FOR FACE, BODY AND HAND CARE; PERFUMED MOISTURIZING CREAMS FOR FACE, BODY AND HAND CARE; SKIN CARE PREPARATIONS, NOT FOR MEDICAL PURPOSES; ANTI-WRINKLE CREAMS; PERFUMERY PRODUCTS, NAMELY, PERFUMERY AND PERSONAL BODY DEODORANTS, COSMETIC SKIN PREPARATIONS; HAIR CREAMS, HAIR LOTIONS, MAKE-UP PREPARATIONS, LIPSTICKS; COSMETIC SKIN LIGHTENING PREPARATIONS, DEPILATORY CREAMS; DEPILATORY PREPARATIONS; GELS, NAMELY, COSMETIC PREPARATIONS FOR SKIN CARE; NAIL CARE PREPARATIONS (U.S. CLS. 1, 4, 6, 50, 51 AND 52).

CLASS 8—HAND TOOLS

FOR ELECTRIC APPARATUS TO REMOVE HAIR AND PREVENT ITS REGROWTH, VIA A THERMAL EFFECT CAUSED BY THE EMISSION OF FLASHES OF LIGHT (U.S. CLS. 23, 28 AND 44).

CLASS 10—MEDICAL APPARATUS

FOR ELECTRIC PHOTOTHERAPY APPARATUS WHICH EMIT FLASHES OF LIGHT OR NON-PULSED LIGHT, IN PARTICULAR FOR THE TREATMENT OF SKIN OR VASCULAR BLEMISHES OR LESIONS; ELECTRIC SKIN TREATMENT APPARATUS WHICH EMIT FLASHES OF LIGHT OR NON-PULSED LIGHT FOR BIOSTIMULATION, PHOTOREJUVENATION OR PHOTOEPILATION (U.S. CLS. 26, 39 AND 44).

CLASS 44—MEDICAL, BEAUTY AND AGRICULTURAL SERVICES

FOR DERMATOLOGICAL SERVICES; HYGIENIC AND BEAUTY CARE FOR HUMAN BEINGS, NAMELY, BEAUTY SERVICES, HAIR REMOVAL AND PHOTOREJUVENATION BY EXPOSURE TO PULSED OR NON-PULSED LIGHT, TREATMENT OF STRETCH MARKS (U.S. CLS. 100 AND 101).

SEAN CROWLEY, EXAMINING ATTORNEY

CLASS 5—PHARMACEUTICALS

FOR MEDICATED LIP BALMS AND BALMS FOR THERAPEUTIC OR MEDICINAL PURPOSES; BANDAGES, NAMELY, SURGICAL BANDAGES, WOUND PROTECTION BANDAGES AND PRESSURE BANDAGES; ADHESIVE BANDS FOR THERAPEUTIC OR MEDICINAL PURPOSES, AND DRESSINGS FOR WOUNDS; ANTISEPTICS; DISINFECTANT CREAMS, DISINFECTANT POWDERS AND DISINFECTANT OINTMENTS FOR HYGIENIC PURPOSES; GERMICIDES; ABSORBENT COTTON FOR MEDICAL PURPOSES; ANALGESICS AND HEADACHE TABLETS; EYE WASHES; VITAMIN AND/OR MINERAL SUPPLEMENTS; LINT FOR THERAPEUTIC OR MEDICINAL PURPOSES; SEDATIVES; SALTS FOR MEDICAL PURPOSES AND SMELLING SALTS; IODINE PREPARATIONS; FIRST AID KITS, MEDICAL KITS AND SURVIVAL KITS CONTAINING MEDICATIONS; FIRST AID KITS, MEDICAL KITS AND SURVIVAL KITS CONTAINING MEDICATIONS FOR SURFERS AND RELATED ACCESSORIES SOLD THEREWITH (U.S. CLS. 6, 18, 44, 46, 51 AND 52).

CLASS 18—LEATHER GOODS

FOR LUGGAGE, SUITCASES AND BAGS, NAMELY, TRAVEL BAGS, TOTE BAGS, DAYPACKS, BACKPACKS, RUCKSACKS, SHOULDER BAGS, OVERNIGHT BAGS, MONEY BAGS, TRAVEL PACKS, SCHOOL PACKS, BRIEFCASES, TOILETRY BAGS SOLD EMPTY, WAIST BAGS AND ALL PURPOSE BAGS FOR SPORTING EQUIPMENT AND/OR SPORTING ARTICLES; WALLETS AND PURSES; POUCHES, NAMELY, POUCHES FOR FIRST AID ITEMS SOLD EMPTY AND POUCHES FOR SURFING ACCESSORIES SOLD EMPTY; LUGGAGE TAGS; UMBRELLAS; ACCESSORIES FOR THE AFORESAID GOODS SOLD THEREWITH (U.S. CLS. 1, 2, 3, 22 AND 41).

CLASS 25—CLOTHING

FOR CLOTHING, FOOTWEAR AND HEADGEAR, NAMELY, SHORTS, SHIRTS, T-SHIRTS, SINGLETs, SKIRTS, DRESSES, RAINCOATS, JACKETS, JUMPERS, SWIMSUITS, BOARD SHORTS, WETSUITS, RASH VESTS, HATS, CAPS, SUN VISORS, BEANIES, BOOTS, SHOES, SANDALS, THONGS, SLIPPERS AND SOCKS; NECKTIES; ACCESSORIES NAMELY SCARFS, BANDANAS AND TIES; MONEY BELTS (U.S. CLS. 22 AND 39).

JOHN WILKE, EXAMINING ATTORNEY

SN 79-099,570. TORO FERTILIZANTES S.L.U., SPAIN, FILED 4-4-2011.



OWNER OF INTERNATIONAL REGISTRATION 1083092 DATED 4-4-2011, EXPIRES 4-4-2021.

THE COLOR(S) RED, ORANGE AND BLACK IS/ARE CLAIMED AS A FEATURE OF THE MARK.

THE MARK CONSISTS OF THE BLACK WORDING "FERTORO" AND A RED AND ORANGE IMAGE OF A BULL.

THE ENGLISH TRANSLATION OF "TORO" IN THE MARK IS BULL.

CLASS 1—CHEMICALS

FOR CHEMICALS USED IN AGRICULTURE, HORTICULTURE AND FORESTRY EXCEPT FUNGICIDES, HERBICIDES, INSECTICIDES AND PARASITICIDES; FERTILIZERS (U.S. CLS. 1, 5, 6, 10, 26 AND 46).

CLASS 5—PHARMACEUTICALS

FOR PREPARATIONS FOR DESTROYING VERMIN; FUNGICIDES, HERBICIDES (U.S. CLS. 6, 18, 44, 46, 51 AND 52).

KRISTINA MORRIS, EXAMINING ATTORNEY

SN 79-099,624. STIBO A/S, DENMARK, FILED 6-7-2011.

MAGPEOPLE

THE MARK CONSISTS OF STANDARD CHARACTERS WITHOUT CLAIM TO ANY PARTICULAR FONT, STYLE, SIZE, OR COLOR.

PRIORITY DATE OF 12-13-2010 IS CLAIMED.

OWNER OF INTERNATIONAL REGISTRATION 1083245 DATED 6-7-2011, EXPIRES 6-7-2021.

CLASS 9—ELECTRICAL AND SCIENTIFIC APPARATUS

FOR COMPUTER SOFTWARE FOR USE IN CONNECTION WITH PRODUCTION, PUBLISHING AND DISTRIBUTION OF PRINTED AND DIGITAL MAGAZINES RECORDED ON TAPES, OPTICAL DISKS, MAGNETIC DISKS, SEMICONDUCTORBASED MEMORY; DOWNLOADABLE COMPUTER SOFTWARE FOR USE IN CONNECTION WITH PRODUCTION, PUBLISHING AND DISTRIBUTION OF PRINTED AND DIGITAL MAGAZINES; COMPUTER PROGRAMS FOR USE IN CONNECTION WITH PRODUCTION, PUBLISHING AND DISTRIBUTION OF PRINTED AND DIGITAL MAGAZINES RECORDED ON TAPES, OPTICAL DISKS, MAGNETIC DISKS, SEMICONDUCTORBASED MEMORY (U.S. CLS. 21, 23, 26, 36 AND 38).

CLASS 16—PAPER GOODS AND PRINTED MATTER

FOR PRINTED MATTER, NAMELY, MAGAZINES, PAPER SIGNS, BOOKS, MANUALS, CURRICULUM, NEWSLETTERS, INFORMATIONAL CARDS AND BROCHURES IN THE FIELD OF THE PRODUCTION, PUBLISHING AND DISTRIBUTION OF PRINTED AND DIGITAL MAGAZINES; BOOKBINDING MATERIAL; PHOTOGRAPHS; STATIONERY; ADHESIVES FOR STATIONERY OR HOUSEHOLD PURPOSES; INSTRUCTIONAL AND TEACHING MATERIALS, NAMELY, MAGAZINES, PAPER SIGNS, BOOKS, MANUALS, CURRICULUM, NEWSLETTERS, INFORMATIONAL CARDS AND BROCHURES IN THE FIELD OF THE PRODUCTION, PUBLISHING AND DISTRIBUTION OF PRINTED AND DIGITAL MAGAZINES; PLASTIC MATERIALS FOR PACKAGING, NAMELY, PLASTIC BAGS FOR PACKAGING; PRINTER'S TYPE, PRINTING BLOCKS (U.S. CLS. 2, 5, 22, 23, 29, 37, 38 AND 50).

CLASS 42—SCIENTIFIC AND COMPUTER SERVICES

FOR DESIGN, UPDATING, MAINTENANCE AND REPAIR OF COMPUTER SOFTWARE; COMPUTER PROGRAMMING, TECHNOLOGICAL CONSULTING REGARDING IMPLEMENTATION AND USE OF COMPUTER SOFTWARE AND COMPUTER PROGRAMS (U.S. CLS. 100 AND 101).

ROSELLE HERRERA, EXAMINING ATTORNEY

SN 79-099,629. LSCH, FRANCE, FILED 3-30-2011.

Dement

PRIORITY DATE OF 11-23-2010 IS CLAIMED. OWNER OF INTERNATIONAL REGISTRATION 1083264 DATED 3-30-2011, EXPIRES 3-30-2021.

THE MARK CONSISTS OF THE WORD "DEMENT" IN STYLIZED FONT.

THE WORD "DEMENT" CAN BE TRANSLATED FROM FRENCH INTO ENGLISH AS "MADNESS", "UNREASONABLENESS" AND/OR "EXTRAVAGANCE".

CLASS 25—CLOTHING

FOR WOMEN'S CLOTHING, NAMELY, DRESSES, SKIRTS, TOPS, PANTS, T-SHIRTS, SHIRTS, POLO SHIRTS, SWEATERS, JACKETS, COATS, CARDIGANS, AND GLOVES; WOMEN'S HEADGEAR FOR WEAR, NAMELY, HEADWEAR, HATS, CAPS, BERETS; WOMEN'S FOOTWEAR, EXCLUDING ORTHOPEDIC FOOTWEAR; WOMEN'S BELTS; TIGHTS; BABY DOLLS, NAMELY, PAJAMAS, T-SHIRTS AND TOPS; BUSTIERS; SLIPS; WOMEN'S UNDERWEAR; BREECHES FOR WEAR; BRASSIERES; WOMEN'S DRESSING GOWNS; WOMEN'S PAJAMAS; UNDERPANTS; WOMEN'S CLOTHING OF LEATHER, NAMELY, SKIRTS, TOPS, PANTS, JACKETS, COATS AND GLOVES; WOMEN'S CLOTHING OF IMITATIONS OF LEATHER, NAMELY, SKIRTS, TOPS, PANTS, JACKETS, COATS, AND GLOVES; ALL OF THE AFORESAID GOODS EXCLUDING SPORTS CLOTHING (U.S. CLS. 22 AND 39).

CLASS 26—FANCY GOODS

FOR LACE AND EMBROIDERY; RIBBONS; BRAIDS; HOOKS AND EYELETS; SILVER EMBROIDERY FOR GARMENTS; FASTENINGS FOR CLOTHING, NAMELY, BUTTONS; CORSET BUSKS, NAMELY, METAL CLASPS FOR CORSETS; HAIR BANDS; BARRETTES; BUCKLES FOR BELTS; BROOCHES FOR CLOTHING; BELT CLASPS; HAT ORNAMENTS, NOT OF PRECIOUS METAL; HAIR ORNAMENTS; FASTENINGS FOR CLOTHING, NAMELY, CLOSURE CLIPS, SNAP FASTENERS, BUTTONS, RIVETS, BUCKLES, RINGS AND LOCKS; HAIR NETS; ARTIFICIAL FLOWERS; NUMERALS AND LETTERS FOR MARKING LINEN, NUMERALS AND LETTERS MADE OF TEXTILE TO BE EMBROIDERED ON LINEN; HAT ORNAMENTS NOT OF PRECIOUS METAL; ORNAMENTAL NOVELTY BADGES; SHOE ORNAMENTS, NOT OF PRECIOUS METAL; LACE TRIMMINGS; SKIRT FLOUNCES, NAMELY, ORNAMENTAL MATERIALS OR FRILLS SEWN ONTO FABRIC FOR TRIMMING CLOTHING; SPANGLES FOR CLOTHING (U.S. CLS. 37, 39, 40, 42 AND 50).

FRANK LATTUCA, EXAMINING ATTORNEY

PRIORITY DATE OF 11-17-2010 IS CLAIMED.
OWNER OF INTERNATIONAL REGISTRATION 1083422
DATED 5-3-2011, EXPIRES 5-3-2021.

CLASS 20—FURNITURE AND ARTICLES NOT OTHERWISE CLASSIFIED

FOR FURNITURE, MIRRORS, PICTURE FRAMES (U.S. CLS. 2, 13, 22, 25, 32 AND 50).

CLASS 24—FABRICS

FOR TEXTILES AND TEXTILE GOODS, NOT INCLUDED IN OTHER CLASSES, NAMELY, FURNITURE UPHOLSTERY FABRIC, FURNITURE COVERINGS OF TEXTILE, LOOSE UNFITTED FABRIC COVERS FOR FURNITURE; BED AND TABLE COVERS OF TEXTILE FABRICS; UPHOLSTERY FABRICS; TEXTILE MATERIALS, NAMELY, VINYL-COATED POLYESTER FABRIC; NON-WOVEN TEXTILE FABRICS (U.S. CLS. 42 AND 50).

YAT SYE, LEE, EXAMINING ATTORNEY

SN 79-099,731. WERDOL BEHEERMAATSCHAPPIJ B.V.,
NETHERLANDS, FILED 5-13-2011.

EPIFANES 

PRIORITY DATE OF 2-1-2011 IS CLAIMED.
OWNER OF INTERNATIONAL REGISTRATION 1083390
DATED 5-13-2011, EXPIRES 5-13-2021.

OWNER OF U.S. REG. NO. 1,430,768.

THE MARK CONSISTS OF THE STYLIZED WORDING "EPIFANES" WITH A PEACOCK DESIGN TO THE RIGHT. THE WORDING "EPIFANES" HAS NO MEANING IN A FOREIGN LANGUAGE.

CLASS 2—PAINTS

FOR PAINTS, LACQUERS, VARNISHES, PAINT THINNERS (U.S. CLS. 6, 11 AND 16).

CLASS 3—COSMETICS AND CLEANING PREPARATIONS

FOR PREPARATIONS FOR CLEANING, POLISHING AND STAIN REMOVING AND ABRASIVE PREPARATIONS, SCOURING SOLUTIONS (U.S. CLS. 1, 4, 6, 50, 51 AND 52).

CLASS 35—ADVERTISING AND BUSINESS

FOR MEDIATION OF AGREEMENTS AND COMMERCIAL TRANSACTIONS FOR THE PURCHASE AND SALE OF PAINT PRODUCTS; WHOLESALE STORE AND RETAIL STORE SERVICES FEATURING PAINT PRODUCTS; EXPORT AND IMPORT AGENCIES IN THE FIELD OF PAINT PRODUCTS (U.S. CLS. 100, 101 AND 102).

DAVID HOFFMAN, EXAMINING ATTORNEY

SN 79-099,742. TRIP TRAP DENMARK A/S, DENMARK,
FILED 5-3-2011.

SunTexture

THE MARK CONSISTS OF STANDARD CHARACTERS WITHOUT CLAIM TO ANY PARTICULAR FONT, STYLE, SIZE, OR COLOR.

SN 79-099,898. RDPR LIMITED, UNITED KINGDOM, FILED
6-16-2011.

INDOLENT

THE MARK CONSISTS OF STANDARD CHARACTERS WITHOUT CLAIM TO ANY PARTICULAR FONT, STYLE, SIZE, OR COLOR.

PRIORITY DATE OF 3-17-2011 IS CLAIMED.

OWNER OF INTERNATIONAL REGISTRATION 1083885
DATED 6-16-2011, EXPIRES 6-16-2021.

CLASS 3—COSMETICS AND CLEANING PREPARATIONS

FOR PERFUMERY, ESSENTIAL OILS, COSMETICS, HAIR LOTIONS; DENTIFRICES; PERFUMES AND PERFUMERY PRODUCTS, NAMELY, COLOGNE, AFTERSHAVE AND FRAGRANCES; AROMATIC SUBSTANCES FOR USE IN THE MANUFACTURE OF PERFUMES, NAMELY, AROMATIC OILS AND AROMATIC ESSENTIAL OILS; FINE FRAGRANCE; PERFUMED BATH FOAM PREPARATIONS, NAMELY, PERFUMED BATH FOAM AND FOAM CLEANSERS FOR PERSONAL USE; PERFUMED BATH SALTS; PERFUMED BEAUTY MILKS, BATH MILKS AND CLEANSING MILKS; PERFUMED FACE AND BODY SPRAYS; PERFUMED SOAPS (U.S. CLS. 1, 4, 6, 50, 51 AND 52).

CLASS 4—LUBRICANTS AND FUELS

FOR PERFUMED CANDLES (U.S. CLS. 1, 6 AND 15).
SHAILA SETTLES, EXAMINING ATTORNEY

SN 79-100,076. KEMIRA OYJ, FINLAND, FILED 6-20-2011.

KEMTALO

THE MARK CONSISTS OF STANDARD CHARACTERS WITHOUT CLAIM TO ANY PARTICULAR FONT, STYLE, SIZE, OR COLOR.

PRIORITY DATE OF 5-30-2011 IS CLAIMED.

OWNER OF INTERNATIONAL REGISTRATION 1084334
DATED 6-20-2011, EXPIRES 6-20-2021.

THE WORDING "KEMTALO" HAS NO MEANING IN A FOREIGN LANGUAGE.

CLASS 1—CHEMICALS

FOR CHEMICALS AND ENZYMES USED IN THE SUGAR CANE AND SUGAR BEET PROCESSING INDUSTRY, AS WELL AS IN AGRICULTURE, HORTICULTURE AND FORESTRY; MANURES; CHEMICALS FOR PRESERVING FOODSTUFFS; CHEMICALS AND ENZYMES USED IN DIFFERENT PHASES OF SUGAR PROCESSING IN THE SUGAR CANE AND SUGAR BEET PROCESSING INDUSTRY; CHEMICALS AND ENZYMES USED IN DIFFERENT PHASES OF BIOETHANOL PROCESSING IN THE SUGAR CANE AND SUGAR BEET PROCESSING INDUSTRY (U.S. CLS. 1, 5, 6, 10, 26 AND 46).

CLASS 5—PHARMACEUTICALS

FOR ALL PURPOSE DISINFECTANTS; PREPARATIONS FOR DESTROYING VERMIN; BIOCIDES (U.S. CLS. 6, 18, 44, 46, 51 AND 52).

LINDA MICKLEBURGH, EXAMINING ATTORNEY

PLAYS; DOWNLOADABLE PROGRAMS FOR HAND-HELD GAMES WITH LIQUID CRYSTAL DISPLAYS (U.S. CLS. 21, 23, 26, 36 AND 38).

CLASS 28—TOYS AND SPORTING GOODS

FOR COIN-OPERATED ARCADE VIDEO GAME MACHINES; MAGNETIC CARD OPERATED ARCADE VIDEO GAME MACHINES; ARCADE VIDEO GAME MACHINES WITH MULTI-TERMINALS; CABINETS FOR ARCADE VIDEO GAME MACHINES; ARCADE VIDEO GAME MACHINES; SLOT MACHINES; CABINETS OF SLOT MACHINES; GAMING MACHINES OTHER THAN THOSE ADAPTED FOR USE WITH AN EXTERNAL DISPLAY SCREEN OR MONITOR; GAMING MACHINES WITH MULTI-TERMINALS OTHER THAN THOSE ADAPTED FOR USE WITH AN EXTERNAL DISPLAY SCREEN OR MONITOR; HAND-HELD GAMES WITH LIQUID CRYSTAL DISPLAYS (U.S. CLS. 22, 23, 38 AND 50).

EDWARD NELSON, EXAMINING ATTORNEY

SN 79-100,098. UNIVERSAL ENTERTAINMENT CORPORATION, TOKYO, JAPAN, FILED 5-25-2011.



PRIORITY DATE OF 5-12-2011 IS CLAIMED.
OWNER OF INTERNATIONAL REGISTRATION 1084383 DATED 5-25-2011, EXPIRES 5-25-2021.

THE MARK CONSISTS OF TWO CHERRIES ATTACHED TO A STEM WITH SUN RAYS APPEARING BEHIND THE CHERRIES, THE WORDS "CHERRY CHANCE" WITH AN IRREGULAR GEOMETRIC SHAPE IN THE BACKGROUND AND THE WORDS "HOT SEVEN" IN CURSIVE WRITING WITH FLAMES COMING FROM BEHIND THE WORDS.

CLASS 9—ELECTRICAL AND SCIENTIFIC APPARATUS

FOR ELECTRONIC CIRCUITS, OPTICAL DISKS, MAGNETIC TAPES, MAGNETIC DISKS, MAGNETIC CARDS, MAGNETO-OPTICAL DISKS, CD-ROMS, ROM-CARTRIDGES AND DVDS, ALL OF WHICH STORE PROGRAMS FOR ARCADE VIDEO GAME MACHINES; DOWNLOADABLE PROGRAMS FOR ARCADE VIDEO GAME MACHINES; GAMING MACHINES ADAPTED FOR USE WITH AN EXTERNAL DISPLAY SCREEN OR MONITOR; GAMING MACHINES WITH MULTI-TERMINALS ADAPTED FOR USE WITH AN EXTERNAL DISPLAY SCREEN OR MONITOR; ELECTRONIC CIRCUITS, OPTICAL DISKS, MAGNETIC TAPES, MAGNETIC DISKS, MAGNETO-OPTICAL DISKS, CD-ROMS, ROM-CARTRIDGES AND DVDS, ALL OF WHICH STORE PROGRAMS FOR GAMING MACHINES; DOWNLOADABLE PROGRAMS FOR GAMING MACHINES; ELECTRONIC CIRCUITS, OPTICAL DISKS, MAGNETIC TAPES, MAGNETIC DISKS, MAGNETO-OPTICAL DISKS, CD-ROMS, ROM-CARTRIDGES AND DVDS, ALL OF WHICH STORE PROGRAMS FOR SLOT MACHINES; APPARATUS FOR GAMES FOR HOME USE ADAPTED FOR USE WITH AN EXTERNAL DISPLAY SCREEN OR MONITOR; ELECTRONIC CIRCUITS, OPTICAL DISKS, MAGNETIC TAPES, MAGNETIC DISKS, MAGNETO-OPTICAL DISKS, CD-ROMS, ROM-CARTRIDGES AND DVDS, ALL OF WHICH STORE PROGRAMS FOR GAMES FOR HOME USE ADAPTED FOR USE WITH AN EXTERNAL DISPLAY SCREEN OR MONITOR; DOWNLOADABLE PROGRAMS FOR GAMES FOR HOME USE ADAPTED FOR USE WITH AN EXTERNAL DISPLAY SCREEN OR MONITOR; ELECTRONIC CIRCUITS, OPTICAL DISKS, MAGNETIC TAPES, MAGNETIC DISKS, MAGNETO-OPTICAL DISKS, CD-ROMS, ROM-CARTRIDGES AND DVDS, ALL OF WHICH STORE PROGRAMS FOR HAND-HELD GAMES WITH LIQUID CRYSTAL DIS-

SN 79-100,433. JUDO WASSERAUFBEREITUNG GMBH, FED REP GERMANY, FILED 5-11-2011.

i-lution

THE MARK CONSISTS OF STANDARD CHARACTERS WITHOUT CLAIM TO ANY PARTICULAR FONT, STYLE, SIZE, OR COLOR.

PRIORITY DATE OF 11-23-2010 IS CLAIMED.
OWNER OF INTERNATIONAL REGISTRATION 1085141 DATED 5-11-2011, EXPIRES 5-11-2021.

CLASS 9—ELECTRICAL AND SCIENTIFIC APPARATUS

FOR DOSING DEVICES, NAMELY, MECHANICAL DEVICES CONSISTING OF DISPENSERS HAVING PRESET PORTIONS OF FLUIDS OR AGENTS AND ATTACHED DOSING PUMPS, NOT FOR MEDICAL USE (U.S. CLS. 21, 23, 26, 36 AND 38).

CLASS 11—ENVIRONMENTAL CONTROL APPARATUS

FOR WATER PURIFICATION APPARATUS AND SYSTEM COMPRISED PRIMARILY OF WATER PURIFICATION INSTALLATIONS, SPECIFICALLY FOR THE ECO-FRIENDLY AND/OR CHEMICAL-FREE TREATMENT OF WATER; WATER SOFTENING UNITS; WATER CONDITIONING SYSTEMS COMPRISED PRIMARILY OF CONDITIONING UNITS; WATER FILTERS; DESALINATION SYSTEMS COMPRISED PRIMARILY OF DESALINATION UNITS; LIMESTONE PREVENTION SYSTEMS SUBSTANTIALLY CONSISTING OF WATER TREATMENT FILTRATION UNITS, REVERSE OSMOSIS UNITS, CHEMICAL STERILIZATION UNITS FOR PREVENTION OF LIMESCALE BUILD-UP (U.S. CLS. 13, 21, 23, 31 AND 34).

SAIMA MAKHDOOM, EXAMINING ATTORNEY

SN 79-100,760. GEA PROCESS ENGINEERING A/S, DENMARK, FILED 3-11-2011.

SANICOVER

THE MARK CONSISTS OF STANDARD CHARACTERS WITHOUT CLAIM TO ANY PARTICULAR FONT, STYLE, SIZE, OR COLOR.

OWNER OF INTERNATIONAL REGISTRATION 1085996 DATED 3-11-2011, EXPIRES 3-11-2021.

CLASS 6—METAL GOODS

FOR FLANGES OF METAL AND SIGHT HOLE COVERS OF METAL AND CLEANING HOLE COVERS OF METAL, ALL FOR USE IN INDUSTRIAL PROCESS EQUIPMENT AND RELATED DUCTING AND PIPING (U.S. CLS. 2, 12, 13, 14, 23, 25 AND 50).

CLASS 7—MACHINERY

FOR MACHINE PARTS, NAMELY, FLANGES AND SIGHT HOLE COVERS AND CLEANING HOLE COVERS (U.S. CLS. 13, 19, 21, 23, 31, 34 AND 35).

SETH A. RAPPAPORT, EXAMINING ATTORNEY

SN 79-100,829. DE BADEREAU THIERRY, FRANCE, FILED 6-16-2011.



PRIORITY DATE OF 3-25-2011 IS CLAIMED. OWNER OF INTERNATIONAL REGISTRATION 1086163 DATED 6-16-2011, EXPIRES 6-16-2021.

NO CLAIM IS MADE TO THE EXCLUSIVE RIGHT TO USE "ST BARTH", APART FROM THE MARK AS SHOWN.

THE MARK CONSISTS OF A SUNSET WITH THREE SEAGULLS OVER OCEAN WAVES ABOVE THE WORDING "FREE IN ST BARTH".

CLASS 9—ELECTRICAL AND SCIENTIFIC APPARATUS

FOR SCIENTIFIC, NAUTICAL, SURVEYING, PHOTOGRAPHIC, CINEMATOGRAPHIC AND OPTICAL APPARATUS AND INSTRUMENTS, NAMELY, CAMERAS, UNDERWATER HOUSINGS FOR CAMERAS, UNDERWATER ENCLOSURES FOR CAMERAS; OPTICAL APPARATUS AND INSTRUMENTS, NAMELY, SUNGLASSES, SPORTS GLASSES, OPTICAL GLASSES, EYEGLASS FRAMES, EYEGLASS CHAINS AND CORDS, EYEGLASS CASES, EYEGLASS LENSES, OPTICAL LENSES, CONTACT LENSES, CASES FOR CONTACT LENSES, BINOCULARS; APPARATUS FOR RECORDING, TRANSMITTING OR REPRODUCING SOUNDS OR IMAGES; PRERECORDED DATA MEDIA IN THE FIELD OF MUSIC AND MOVIES, NAMELY, DISKETTES, MAGNETIC TAPES, VIDEO AND AUDIO CASSETTES, CD-ROMS, DIGITAL VIDEO DISKS, DIGITAL VERSATILE DISKS (DVDs), MAGNETIC DISKS, OPTICAL DISKS, AUDIO-VIDEO COMPACT DISKS; TEACHING APPARATUS AND INSTRUMENTS, NAMELY, MICROSCOPES; APPARATUS AND INSTRUMENTS FOR DATA PROCESSING, NAMELY, COMPUTERS, DATA PROCESSORS (U.S. CLS. 21, 23, 26, 36 AND 38).

CLASS 14—JEWELRY

FOR JEWELRY, PRECIOUS STONES; HOROLOGICAL AND CHRONOMETRIC INSTRUMENTS; WATCH BANDS, WATCH CHAINS, WATCH CRYSTALS, CHRONOMETERS, CLOCK AND WATCH HANDS, CLOCK AND WATCH-MAKING PENDULUMS, DIALS FOR CLOCK-AND-WATCH-MAKING, CASES AND PRESENTATION CASES FOR TIMEPIECES; NECKLACES; COSTUME JEWELRY, CHARMS, KEY RINGS OF PRECIOUS METAL, FIGURINES OF PRECIOUS METAL, INSIGNIA OF PRECIOUS METAL, MEDALS, MEDALLIONS, PERSONAL ORNAMENTS OF PRECIOUS METAL, BEADS FOR USE IN THE MANUFACTURE OF JEWELRY, STATUES OF PRECIOUS METAL, STATUETTES OF PRECIOUS METAL AS ORNAMENTS OR TO BE ATTACHED TO MOBILE TELEPHONES (U.S. CLS. 2, 27, 28 AND 50).

CLASS 18—LEATHER GOODS

FOR LEATHER AND IMITATION LEATHER; GOODS MADE OF LEATHER OR IMITATION LEATHER, NAMELY, LUGGAGE EXCEPT BAGS OF TEXTILE FOR PACKAGING AND BAGS FOR THE TRANSPORT AND STORAGE OF MATERIALS IN BULK, TRAVEL BAGS, SPORTS BAGS EXCEPT FOR BAGS SPECIFICALLY DESIGNED TO HOLD THE SPORTS ARTICLES ARE MEANT TO CARRY, LEATHER GOODS IN THE NATURE OF LEATHER WALLETS, LEATHER POUCHES, UNFITTED VANITY CASES, TOILETRY CASES SOLD EMPTY, HANDBAGS, BEACH BAGS, BACKPACKS, TENNIS BAGS IN THE NATURE OF ALL-PURPOSE SPORT BAGS, GYM BAGS, HEALTH CLUB BAGS IN THE NATURE OF ALL-PURPOSE SPORT BAGS, SHOE BAGS FOR TRAVEL, ATTACHÉ CASES, SATCHELS, WALLETS, CREDIT CARD HOLDERS, PURSES, PURSES NOT OF PRECIOUS METAL, POUCHES FOR WEAR AROUND THE WAIST IN THE NATURE OF WAIST PACKS, POUCHES, NAMELY, LEATHER POUCHES, POUCHES FOR HOLDING KEYS; SKINS, HIDES AND PELTS; TRUNKS AND SUITCASES; UMBRELLAS, PARASOLS AND WALKING STICKS; WHIPS, HARNESS AND SADDLERY (U.S. CLS. 1, 2, 3, 22 AND 41).

CLASS 20—FURNITURE AND ARTICLES NOT OTHERWISE CLASSIFIED

FOR PILLOWS (U.S. CLS. 2, 13, 22, 25, 32 AND 50).

CLASS 24—FABRICS

FOR FABRICS FOR TEXTILE USE; HOUSEHOLD LINEN; BED LINEN, NAMELY, SHEETS, FITTED SHEETS, PILLOWCASES, BOLSTER COVERS, BED BLANKETS, BED COVERS, COMFORTERS, QUILT COVERS, EIDERDOWNS; TEXTILE CURTAINS, COVERS FOR CUSHIONS; TABLE LINEN, NAMELY, TABLE-CLOTHS OF TEXTILE, TEXTILE NAPKINS, TEXTILE TABLE MATS; BATH LINEN, NAMELY, WASHCLOTHS, FACE TOWELS OF TEXTILE, BATH TOWELS OF TEXTILE, BEACH TOWELS OF TEXTILE (U.S. CLS. 42 AND 50).

CLASS 25—CLOTHING

FOR CLOTHING, NAMELY, SKIRTS, DRESSES, LONG DRESSES, TROUSERS, JEANS, BERMUDA SHORTS, SHORTS, BOXER SHORTS, SINGLET, SHIRTS, T-SHIRTS, POLO SHIRTS, SPORT SHIRTS, LONG SLEEVE SHIRTS, SHORT SLEEVE SHIRTS, TOPS, TANK TOPS, CHASUBLES, BLOUSES, OVERALLS, SUITS, WAISTCOATS, PULL-OVERS, CARDIGANS, RAINCOATS, JACKETS, VESTS, COATS, DUFFLECOATS, OVERCOATS, TOPCOATS, BLOUSONS, BLAZERS, PARKAS, BATHING TRUNKS, BATHING SUITS, BATH ROBES, TIES, NECKTIES, SCARVES, SASHES FOR WEAR, BELTS, BRASSIERES, BREECHES FOR WEAR, SLIPS, PANTS, UNDERPANTS, STOCKINGS, TIGHTS, SOCKS, STOCKINGS, PAJAMAS, DRESSING GOWNS, GLOVES; FOOTWEAR; HEADGEAR, NAMELY, HATS, CAPS (U.S. CLS. 22 AND 39).

LEIGH LOWRY, EXAMINING ATTORNEY

SN 79-100,848. LATI INDUSTRIA TERMOPLASTICI S.P.A., ITALY, FILED 5-31-2011.

LATER

THE MARK CONSISTS OF STANDARD CHARACTERS WITHOUT CLAIM TO ANY PARTICULAR FONT, STYLE, SIZE, OR COLOR.

OWNER OF INTERNATIONAL REGISTRATION 0850425 DATED 9-23-2004, EXPIRES 9-23-2014.

CLASS 1—CHEMICALS

FOR UNPROCESSED POLYMERS FOR USE IN INDUSTRIAL MANUFACTURING (U.S. CLS. 1, 5, 6, 10, 26 AND 46).

CLASS 17—RUBBER GOODS

FOR PLASTIC IN EXTRUDED FORM FOR USE IN MANUFACTURE; SEMI-PROCESSED PLASTIC SUBSTANCES IN THE FORM OF PELLETS FOR USE IN INJECTION MOULDING APPLICATIONS (U.S. CLS. 1, 5, 12, 13, 35 AND 50).

CHRISIE B. KING, EXAMINING ATTORNEY

SN 79-100,878. DIC CORPORATION, JAPAN, FILED 4-15-2011.

DAICURE

THE MARK CONSISTS OF STANDARD CHARACTERS WITHOUT CLAIM TO ANY PARTICULAR FONT, STYLE, SIZE, OR COLOR.

OWNER OF INTERNATIONAL REGISTRATION 1086269 DATED 4-15-2011, EXPIRES 4-15-2021.

OWNER OF U.S. REG. NOS. 3,316,042 AND 3,342,722.

CLASS 1—CHEMICALS

FOR CHEMICAL AGENTS FOR COATING OF PAPER, METAL AND PLASTIC SURFACES; INDUSTRIAL CHEMICALS; ULTRAVIOLET CURABLE SYNTHETIC RESINS. UNPROCESSED; UNPROCESSED SYNTHETIC RESINS; UNPROCESSED PLASTICS; ADHESIVES FOR INDUSTRIAL PURPOSES (U.S. CLS. 1, 5, 6, 10, 26 AND 46).

CLASS 2—PAINTS

FOR PRINTING INKS, OTHER THAN "MIMEOGRAPHING INKS" (U.S. CLS. 6, 11 AND 16).

KATHERINE E. HALMEN, EXAMINING ATTORNEY

SN 79-101,265. YUHUAN CHANGFEI VALVE CO.,LTD, CHINA, FILED 7-26-2011.



CHANGFEI VALVE

OWNER OF INTERNATIONAL REGISTRATION 1087286 DATED 7-26-2011, EXPIRES 7-26-2021.

NO CLAIM IS MADE TO THE EXCLUSIVE RIGHT TO USE "VALVE", APART FROM THE MARK AS SHOWN.

THE MARK CONSISTS OF THE STYLIZED WORDING "CHANGFEI VALVE" WITH A DESIGN OF AN INCOMPLETE CIRCLE CONTAINING A CHEVRON DESIGN AND A SMALL SHADED CIRCLE.

CLASS 6—METAL GOODS

FOR VALVES OF METAL, NAMELY, METALLIC DRAIN TRAPS; GUTTER PIPES OF METAL; MANIFOLDS OF METAL FOR PIPELINES; METAL WASH DOWN SPRAY NOZZLES FOR COMMERCIAL AND INDUSTRIAL USE; WATER-PIPES OF METAL; DUCTS AND PIPES OF METAL FOR CENTRAL HEATING INSTALLATIONS; VALVES OF METAL OTHER THAN PARTS OF MACHINES; PIPEWORK OF METAL; CLIPS OF METAL FOR PIPES; WATER-PIPE VALVES OF METAL (U.S. CLS. 2, 12, 13, 14, 23, 25 AND 50).

CLASS 11—ENVIRONMENTAL CONTROL APPARATUS

FOR HYDRANTS; ANTI-SPLASH TAP NOZZLES; HEATING INSTALLATIONS; CENTRAL HEATING SLICES, NAMELY, HEAT PUMPS; WATER CONDUITS INSTALLATIONS, NAMELY, WATER PURIFICATION INSTALLATIONS; WATER-PIPES FOR SANITARY INSTALLATIONS, NAMELY, WATER-PIPES BEING PARTS OF SANITARY FACILITIES; HOT-WATER HEATING SETTING PIPE PARTS BEING PARTS OF HEATING INSTALLATIONS; WATER DISTRIBUTION INSTALLATIONS, NAMELY, WATER FAUCET SPOUT, WATER CLOSETS AND WATER FOUNTAINS; PLUMBING FITTINGS, NAMELY, DRAINS; PIPES BEING PARTS OF SANITARY FACILITIES (U.S. CLS. 13, 21, 23, 31 AND 34).

NATALIE POLZER, EXAMINING ATTORNEY

SN 79-101,299. OMORI TAKASHI, JAPAN, FILED 5-19-2011.

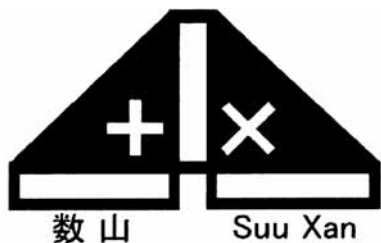

PRIORITY DATE OF 11-26-2010 IS CLAIMED.
OWNER OF INTERNATIONAL REGISTRATION 1087369
DATED 5-19-2011, EXPIRES 5-19-2021.

THE ENGLISH TRANSLATION OF THE WORD "SUU XAN" IN THE MARK IS "MOUNTAIN OF NUMBERS".

THE TRANSLITERATION OF THE NON-LATIN CHARACTERS IN THE MARK IS: "SUU XAN".

CLASS 9—ELECTRICAL AND SCIENTIFIC APPARATUS

FOR ELECTRONIC CIRCUITS AND CD-ROMS RECORDED WITH PROGRAMS FOR HAND-HELD GAMES WITH LIQUID CRYSTAL DISPLAYS; COMPUTER GAME PROGRAMS; COMPUTER GAME SOFTWARE; COMPUTER PUZZLE PROGRAMS; COMPUTER PUZZLE SOFTWARE; DOWNLOADABLE COMPUTER GAME PROGRAMS VIA A GLOBAL COMPUTER NETWORK AND WIRELESS DEVICES; DOWNLOADABLE COMPUTER GAME SOFTWARE VIA A GLOBAL COMPUTER NETWORK AND WIRELESS DEVICES; DOWNLOADABLE COMPUTER PUZZLE PROGRAMS VIA A GLOBAL COMPUTER NETWORK AND WIRELESS DEVICES; DOWNLOADABLE COMPUTER PUZZLE SOFTWARE VIA A GLOBAL COMPUTER NETWORK AND WIRELESS DEVICES; ELECTRONIC DOWNLOADABLE PUBLICATIONS, NAMELY, WORKBOOKS, BOOKS, MAGAZINES AND NEWSPAPERS IN THE FIELD OF PUZZLE; EDUCATIONAL ELECTRONIC DOWNLOADABLE PUBLICATIONS, NAMELY, PUZZLE WORKBOOKS, PUZZLE BOOKS AND PUZZLE MAGAZINES IN THE FIELD OF ARITHMETIC (U.S. CLS. 21, 23, 26, 36 AND 38).

CLASS 16—PAPER GOODS AND PRINTED MATTER

FOR PUBLICATIONS, NAMELY, WORKBOOKS, BOOKS, MAGAZINES AND NEWSPAPERS IN THE FIELD OF PUZZLE; EDUCATIONAL PUBLICATIONS, NAMELY, PUZZLE WORKBOOKS, PUZZLE BOOKS, PUZZLE MAGAZINES AND PRINTED PUZZLES IN THE FIELD OF ARITHMETIC; INDUSTRIAL PACKAGING CONTAINERS OF PAPER; PAPER AND CARDBOARD; STATIONERY (U.S. CLS. 2, 5, 22, 23, 29, 37, 38 AND 50).

ALEXANDER L. POWERS, EXAMINING ATTORNEY

SN 79-101,490. LED-LINEAR GMBH, FED REP GERMANY,
FILED 4-5-2011.

THE MARK CONSISTS OF STANDARD CHARACTERS WITHOUT CLAIM TO ANY PARTICULAR FONT, STYLE, SIZE, OR COLOR.

PRIORITY DATE OF 10-5-2010 IS CLAIMED.
OWNER OF INTERNATIONAL REGISTRATION 1087873
DATED 4-5-2011, EXPIRES 4-5-2021.

CLASS 9—ELECTRICAL AND SCIENTIFIC APPARATUS

FOR LIGHT-EMITTING DIODES, IN PARTICULAR LIGHT-EMITTING DIODES BEING LINED UP ON A BAND AND ELECTRICALLY CONNECTED AS PRE-CONFIGURED ELECTRONIC COMPONENT; ACCUMULATORS; ELECTRIC CABLES; CIRCUIT BOARDS, OPTICAL FIBERS; OPTICAL LAMPS, NAMELY, OPTICAL READERS; FRAMES SPECIFICALLY ADAPTED FOR PHOTOGRAPHIC TRANSPARENCIES AND ILLUMINATED ELECTRONIC SIGNS; ELECTRIC SWITCHES; ELECTRIC POWER SUPPLY UNITS, IN PARTICULAR LOW VOLTAGE POWER SUPPLIES; LIGHT-EMITTING DIODES FOR ILLUMINATION, IN PARTICULAR LIGHT-EMITTING DIODES BEING LINED UP ON A BAND AND ELECTRICALLY CONNECTED (U.S. CLS. 21, 23, 26, 36 AND 38).

CLASS 11—ENVIRONMENTAL CONTROL APPARATUS

FOR LIGHTS, NAMELY, LIGHTING FIXTURES, PORTABLE UTILITY LIGHTS, READING LIGHTS, ELECTRICAL LAMPS; MODULES FOR LIGHTS, IN PARTICULAR MODULES IN THE NATURE OF LIGHTING FIXTURES AND INSTALLATIONS FOR LIGHTS WHICH CAN BE LINED UP NEXT TO EACH OTHER (U.S. CLS. 13, 21, 23, 31 AND 34).

CLASS 38—COMMUNICATION

FOR TELECOMMUNICATION, NAMELY, LOCAL AND LONG DISTANCE TRANSMISSION OF VOICE, DATA, GRAPHICS AND VIDEO BY MEANS OF BROADBAND OPTICAL OR WIRELESS NETWORKS, PROVIDING INTERNET ACCESS VIA BROADBAND OPTICAL OR WIRELESS NETWORKS, WIRELESS TELEPHONE SERVICES; PROVIDING ACCESS TO INFORMATION ON THE INTERNET, NAMELY, PROVIDING MULTIPLE USER ACCESS TO PROPRIETARY COLLECTIONS OF INFORMATION BY MEANS OF GLOBAL COMPUTER INFORMATION NETWORKS; PROVIDING ACCESS TO E-COMMERCE PLATFORMS ON THE INTERNET, NAMELY, PROVIDING MULTIPLE USER ACCESS TO PROPRIETARY COLLECTIONS OF INFORMATION BY MEANS OF GLOBAL COMPUTER INFORMATION NETWORKS; PROVIDING TELECOMMUNICATION CHANNELS FOR TEleshopping SERVICES; PROVIDING E-MAIL SERVICES; PROVIDING USER ACCESS TO INFORMATION ON THE INTERNET, NAMELY, PROVIDING MULTIPLE USER ACCESS TO PROPRIETARY COLLECTIONS OF INFORMATION BY MEANS OF GLOBAL COMPUTER INFORMATION NETWORKS (U.S. CLS. 100, 101 AND 104).

NICHOLAS COLEMAN, EXAMINING ATTORNEY

SN 79-101,522. KLEROO, MONTESSON, FRANCE, FILED 7-8-2011.



PRIORITY DATE OF 2-4-2011 IS CLAIMED.
OWNER OF INTERNATIONAL REGISTRATION 1087953
DATED 7-8-2011, EXPIRES 7-8-2021.

OWNER OF U.S. REG. NO. 3,547,179.
NO CLAIM IS MADE TO THE EXCLUSIVE RIGHT TO USE "POOL", APART FROM THE MARK AS SHOWN.

THE MARK CONSISTS OF THE WORD "BIOCLIMATIC" WITH THREE STYLIZED GLOBES FORMING THE LETTER "O" AND THE WORDING "POOL BY KLEROO" APPEARING DIRECTLY UNDERNEATH WITH ALL APPEARING ON A RECTANGULAR CARRIER.

CLASS 7—MACHINERY

FOR ELECTRIC MOTORS FOR OPERATING COVERS AND SHELTERS FOR SWIMMING POOLS, PONDS AND SPAS (U.S. CLS. 13, 19, 21, 23, 31, 34 AND 35).

CLASS 9—ELECTRICAL AND SCIENTIFIC APPARATUS

FOR ELECTRIC OR ELECTRONIC APPARATUS FOR AUTOMATING SWIMMING POOL, POND AND SPA EQUIPMENT; ELECTRIC OR ELECTRONIC APPARATUS FOR CHECKING SWIMMING POOL, POND AND SPA WATER QUALITY; ELECTRIC OR ELECTRONIC ALARM AND MONITORING APPARATUS AND THEIR CONTROL DEVICES FOR SWIMMING POOLS, PONDS AND SPAS (U.S. CLS. 21, 23, 26, 36 AND 38).

CLASS 37—CONSTRUCTION AND REPAIR

FOR UPKEEP, REPAIR AND MAINTENANCE SERVICES FOR SWIMMING POOLS, PONDS, SPAS AND THEIR EQUIPMENT (U.S. CLS. 100, 103 AND 106).

JACLYN KIDWELL WALKER, EXAMINING ATTORNEY

CLASS 5—PHARMACEUTICALS

FOR PHARMACEUTICAL AND VETERINARY PREPARATIONS, NAMELY, MENSTRUAL SYMPTOM TREATMENT PREPARATIONS; SANITARY PREPARATIONS FOR MEDICAL PURPOSES, INCLUDING PREPARATIONS AND PRODUCTS FOR HEALTH CARE OR FOR HEALTH AND PERSONAL HYGIENE, NAMELY, VAGINAL MOISTURIZERS, VAGINAL ANTIFUNGALS, VAGINAL WASHES, BREAST PADS AND BREAST-NURSING PADS; SANITARY TOWELS, PANTY LINERS, TAMPONS, SANITARY PANTIES FOR MENSTRUATION; MEDICATED MOIST TOWELETTES FOR HYGIENE PURPOSES; DIAPERS FOR INCONTINENCE; INCONTINENCE PANTS; MEDICATED COTTON WOOL AND STICKS FOR BABY CARE, FOR FEMININE HYGIENE AND FOR INDIVIDUALS WITH INCONTINENCE; ABSORBENT COTTON FOR MEDICAL PURPOSES; FOOD FOR BABIES; MEDICAL PLASTERS, MATERIALS FOR DRESSINGS; DISINFECTANTS FOR HYGIENE PURPOSES (U.S. CLS. 6, 18, 44, 46, 51 AND 52).

CLASS 10—MEDICAL APPARATUS

FOR DRAW-SHEETS FOR SICK BEDS FOR MEDICAL AND SANITARY PURPOSES, DRAW-SHEETS FOR SICK BEDS OF PAPER AND CELLULOSE FOR CHANGING DIAPERS (U.S. CLS. 26, 39 AND 44).

SN 79-101,735. PANATHENA BVBA, BELGIUM, FILED 5-2-2011.

MAGICS

THE MARK CONSISTS OF STANDARD CHARACTERS WITHOUT CLAIM TO ANY PARTICULAR FONT, STYLE, SIZE, OR COLOR.

PRIORITY DATE OF 2-20-2011 IS CLAIMED.

OWNER OF INTERNATIONAL REGISTRATION 1088505 DATED 5-2-2011, EXPIRES 5-2-2021.

CLASS 3—COSMETICS AND CLEANING PREPARATIONS

FOR SOAPS FOR BABY CARE AND FOR FEMININE HYGIENE; HAIR LOTIONS, HAIR BALSAM, HAIR CONDITIONERS, HAIR SHampoos, HAIR GELS; SKIN CARE AND BODY CARE PRODUCTS, NAMELY, MOIST TOWELETTES FOR HYGIENE PURPOSES, HAND CREAMS, CREAMS FOR BABY CARE, FOR FEMININE HYGIENE AND FOR INDIVIDUALS WITH INCONTINENCE, FEMININE DEODORANT SPRAYS, FEMININE DEODORANT SUPPOSITORIES, FEMININE HYGIENE CLEANSING TOWELETTES, NON-MEDICATED FOOT LOTIONS, WIPES FOR BABY CARE, FOR FEMININE HYGIENE AND FOR INDIVIDUALS WITH INCONTINENCE; WIPES IMPREGNATED WITH CLEANSERS AND LOTIONS FOR THE SKIN, COTTON WOOL AND COTTON SWABS FOR PERSONAL HYGIENE, BODY LOTIONS FOR BABY CARE, FOR FEMININE HYGIENE AND FOR INDIVIDUALS WITH INCONTINENCE, AND FOR INDIVIDUALS WITH INCONTINENCE, BODY SHampoos FOR BABY CARE, FOR FEMININE HYGIENE AND FOR INDIVIDUALS WITH INCONTINENCE, HAND LOTIONS FOR BABY CARE, FOR FEMININE HYGIENE AND FOR INDIVIDUALS WITH INCONTINENCE, TALCUM POWDER, BUBBLE BATH; DENTIFRICES (U.S. CLS. 1, 4, 6, 50, 51 AND 52).

CLASS 16—PAPER GOODS AND PRINTED MATTER

FOR PAPER AND CELLULOSE GOODS, NAMELY, FACE TOWELS AND HAND TOWELS OF PAPER, TOWELETTES AND DRYING TOWELS FOR ABSORBING BODILY FLUIDS, WIPES NOT IMPREGNATED WITH CHEMICALS OR COMPOUNDS FOR USE WITHIN THE FIELD OF INCONTINENCE, FEMININE HYGIENE AND BABY CARE, DRYING TOWELS FOR USE WITHIN THE FIELD OF INCONTINENCE, FEMININE HYGIENE AND BABY CARE; BABIES' DISPOSABLE DIAPERS; DISPOSABLE PADS FOR DIAPER CHANGING, DISPOSABLE PANTS OF PAPER AND CELLULOSE FOR ABSORBING BODILY FLUIDS; MOIST TOWELETTES OF PAPER AND OF CELLULOSE (U.S. CLS. 2, 5, 22, 23, 29, 37, 38 AND 50).

CLASS 24—FABRICS

FOR FACE, HAND AND BODY TOWELS OF TEXTILES; BED SHEETS (U.S. CLS. 42 AND 50).

CLASS 25—CLOTHING

FOR CLOTHING, NAMELY, BRA PADS, BODILY FLUIDS ABSORBING UNDERWEAR, FLUID ABSORBING BRAS; BABIES' DIAPERS OF TEXTILE MATERIALS, DIAPERS AND BODILY FLUIDS ABSORBING PANTIES MADE OF TEXTILE MATERIALS; BIBS, NOT OF PAPER; HUMIDITY-ABSORBENT UNDERWEAR; CLOTHING INCORPORATING TEXTILE DIAPERS; CLOTHING INCORPORATING VAGINAL FLUIDS ABSORBING TEXTILE MATERIAL (U.S. CLS. 22 AND 39).

CLASS 35—ADVERTISING AND BUSINESS

FOR WHOLESALE AND RETAIL STORE SERVICES WITH REGARD TO FEMININE HYGIENE PRODUCTS, BABY CARE PRODUCTS, INCONTINENCE PRODUCTS, SANITARY PREPARATIONS AND MEDICAL PRODUCTS (U.S. CLS. 100, 101 AND 102).

JAMES STEIN, EXAMINING ATTORNEY

SN 79-101,909. INNO-MOTION AG, ZÜRICH, SWITZERLAND, FILED 7-18-2011.

LIMBIC

THE MARK CONSISTS OF STANDARD CHARACTERS WITHOUT CLAIM TO ANY PARTICULAR FONT, STYLE, SIZE, OR COLOR.

PRIORITY DATE OF 1-20-2011 IS CLAIMED.
OWNER OF INTERNATIONAL REGISTRATION 1088984 DATED 7-18-2011, EXPIRES 7-18-2021.

CLASS 10—MEDICAL APPARATUS

FOR FURNITURE ESPECIALLY MADE FOR MEDICAL AND THERAPEUTIC PURPOSES (U.S. CLS. 26, 39 AND 44).

CLASS 20—FURNITURE AND ARTICLES NOT OTHERWISE CLASSIFIED

FOR CHAIRS (SEATS), EASY CHAIRS AND SLEEPER BERTHS (U.S. CLS. 2, 13, 22, 25, 32 AND 50).

CLASS 28—TOYS AND SPORTING GOODS

FOR SPORTING AND FITNESS APPARATUS, NAMELY, A SPORTS TRAINING DEVICE TO IMPROVE STRENGTH, TONING, CONDITIONING, BALANCE, FLEXIBILITY, COORDINATION AND PROPRICEPTION AND FOR LOOSENING OF TENSION, FOR RELAXATION, AND FOR MOBILIZATION (U.S. CLS. 22, 23, 38 AND 50).

DOUGLAS LEE, EXAMINING ATTORNEY

SN 79-101,957. AB7 INDUSTRIES, FRANCE, FILED 7-26-2011.



PRIORITY DATE OF 5-11-2011 IS CLAIMED.
OWNER OF INTERNATIONAL REGISTRATION 1089113 DATED 7-26-2011, EXPIRES 7-26-2021.

NO CLAIM IS MADE TO THE EXCLUSIVE RIGHT TO USE "TECHNOLOGY", APART FROM THE MARK AS SHOWN.

THE MARK CONSISTS OF THE TERM "BORN WITH" IS SURROUNDED IN ITS UPPER PART BY TWO LINES OF HYPERBOLIC CURVES WHICH TOGETHER PROVIDE VISUAL FORM TO AN INCOMPLETE HEART. HYPERBOLIC LINE LYING ON THE RIGHT OF THE TERM "BORN WITH" HAS A LENGTH MORE IMPORTANT THAN OF THE LEFT OF THE TERM. THE WORD "TECHNOLOGY" IS LOCATED AT THE BOTTOM LINE HYPERBOLIC RIGHT. THE TWO HYPERBOLIC LINES ALMOST TOUCH IN THE UPPER PART, WHILE THEY DO NOT JOIN IN THEIR LOWER PART.

CLASS 5—PHARMACEUTICALS

FOR PHARMACEUTICAL AND VETERINARY PREPARATIONS FOR THE TREATMENT OF THE PAIN, PHARMACEUTICAL AND VETERINARY PREPARATIONS FOR THE TREATMENT OF PERSPIRATION, PHARMACEUTICAL AND VETERINARY PREPARATIONS FOR SKIN CARE, PHARMACEUTICAL AND VETERINARY PREPARATIONS FOR THE TREATMENT OF STRESS SYNDROMES AND FOR THE TREATMENT OF TIREDNESS; SANITARY PREPARATIONS FOR MEDICAL PURPOSES; DIETETIC FOODS ADAPTED FOR MEDICAL USE; FOOD FOR BABIES; MEDICAL PLASTERS AND BANDAGES FOR DRESSINGS; MATERIAL FOR DENTAL FILLINGS AND DENTAL IMPRESSIONS; DISINFECTANTS FOR SANITARY PURPOSES; PESTICIDES; HERBICIDES; MEDICATED BATH PREPARATIONS; SANITARY PADS, PANTIES OR TOWELS; CHEMICAL PREPARATIONS FOR MEDICAL OR PHARMACEUTICAL PURPOSES FOR THE TREATMENT OF THE PAIN, CHEMICAL PREPARATIONS FOR MEDICAL OR PHARMACEUTICAL PURPOSES FOR TREATMENT OF THE FEET, CHEMICAL PREPARATIONS FOR MEDICAL OR PHARMACEUTICAL PURPOSES FOR REDUCING PERSPIRATION, CHEMICAL PREPARATIONS FOR MEDICAL OR PHARMACEUTICAL PURPOSES FOR SKIN CARE; MEDICINAL HERBS; HERBS AND TEAS FOR MEDICINAL PURPOSES; PARASITICIDES; DIETETIC SUGAR FOR MEDICAL PURPOSES; ALLOYS OF PRECIOUS METALS FOR DENTAL PURPOSES (U.S. CLS. 6, 18, 44, 46, 51 AND 52).

CLASS 10—MEDICAL APPARATUS

FOR SURGICAL APPARATUS AND INSTRUMENTS FOR MEDICAL, DENTAL AND VETERINARY USE; ARTIFICIAL LIMBS, EYES AND TEETH; ORTHOPEDIC SUPPORTS; SUTURE MATERIALS; MEDICAL STOCKINGS FOR VARICES; FEEDING BOTTLES; FEEDING BOTTLE TEATS; CLOTHING ESPECIALLY FOR OPERATING ROOMS, NAMELY, SCRUB SUITS; MASSAGE APPARATUS, ESTHETIC MASSAGE APPARATUS; ARTIFICIAL LIMBS; SURGICAL IMPLANTS ARTIFICIAL COMPRISING ARTIFICIAL MATERIALS (U.S. CLS. 26, 39 AND 44).

JENNIFER VASQUEZ, EXAMINING ATTORNEY

SN 79-101,985. NEW YORKER S.H.K. JEANS GMBH & CO. KG, FED REP GERMANY, FILED 11-17-2010.

FISHBONE

THE MARK CONSISTS OF STANDARD CHARACTERS WITHOUT CLAIM TO ANY PARTICULAR FONT, STYLE, SIZE, OR COLOR.

OWNER OF INTERNATIONAL REGISTRATION 0726262 DATED 8-9-1999, EXPIRES 8-9-2019.

CLASS 3—COSMETICS AND CLEANING PREPARATIONS

FOR PRODUCTS FOR BEAUTY AND BODY CARE, NAMELY, SKIN SOAP, BODY SOAP, SHOWER GELS, BODY LOTIONS; PERFUMERY, NAMELY, PERFUMES, EAU DE PERFUME, EAU DE TOILETTE, DEODORANTS FOR PERSONAL USE; COSMETICS, NAMELY, EYE-SHADOW, FOUNDATION MAKE-UP, MAKE-UP CREAMS, MAKE-UP POWDERS, EYE-MAKEUP, NAIL POLISH REMOVER; LIPSTICKS; MAKE-UP (U.S. CLS. 1, 4, 6, 50, 51 AND 52).

CLASS 9—ELECTRICAL AND SCIENTIFIC APPARATUS

FOR EYE GLASSES AND THEIR PARTS, PARTICULARLY SUNGLASSES, SPORTS GLASSES, SKI GLASSES, FRAMES FOR EYE GLASSES, CASES FOR EYES GLASSES (U.S. CLS. 21, 23, 26, 36 AND 38).

CLASS 14—JEWELRY

FOR COSTUME JEWELLERY; HOROLOGICAL AND CHRONOMETRIC INSTRUMENTS; WATCH STRAPS (U.S. CLS. 2, 27, 28 AND 50).

CLASS 18—LEATHER GOODS

FOR BAGS, NAMELY, TRAVELLING BAGS, BACKPACKS, SHOULDER BAGS, HANDBAGS, PURSES, ALL-PURPOSE CARRYING BAGS; SPORTS BAGS, SCHOOL BAGS (U.S. CLS. 1, 2, 3, 22 AND 41).

CLASS 25—CLOTHING

FOR CLOTHING, NAMELY, LONG TROUSERS, JEANS, PANTS, SLACKS, SHORT TROUSERS, SHORTS, BOXER SHORTS, 3/4 LENGTH TROUSERS, SLACKS WITH STRAP UNDER FOOT, CULOTTES, BLOUSES, DRESSES, SWEATERS, SHIRTS, SHORT-SLEEVED SHIRTS, T-SHIRTS, LONG-SLEEVED SHIRTS, SOCKS; FOOTWEAR, HEADGEAR, NAMELY, HATS, CAPS, HEAD KERCHIEFS; OUTERWEAR FOR GENTLEMEN AND LADIES, NAMELY, WAISTCOATS, JACKETS, DENIM JACKETS, COATS, TUNICS, BLAZERS, LOUNGING JACKETS, BOMBER JACKETS, OVERALLS, DUNGAREES; UNDERWEAR; UNDERGARMENTS; BELTS, SCARVES, GLOVES, BATHING FASHION FOR GENTLEMEN AND LADIES, NAMELY, BEACHWEAR, SWIM WEAR, BATHING SUITS, SWIMSUITS AND BATHING TRUNKS; LEISURE AND CITY SHOES FOR GENTLEMEN AND LADIES (U.S. CLS. 22 AND 39).

SUZANNE BLANE, EXAMINING ATTORNEY

SN 79-102,041. NOVO NORDISK A/S, BAGSVAERD, DENMARK, FILED 7-11-2011.

DUAL

THE MARK CONSISTS OF STANDARD CHARACTERS WITHOUT CLAIM TO ANY PARTICULAR FONT, STYLE, SIZE, OR COLOR.

PRIORITY DATE OF 1-11-2011 IS CLAIMED.
OWNER OF INTERNATIONAL REGISTRATION 1089338 DATED 7-11-2011, EXPIRES 7-11-2021.

CLASS 16—PAPER GOODS AND PRINTED MATTER

FOR PUBLICATIONS, NAMELY, LEAFLETS, BOOKS, BOOKLETS, MAGAZINES AND NEWSLETTERS IN THE FIELD OF MEDICAL STUDIES AND RESEARCH REGARDING PHARMACEUTICAL PREPARATIONS FOR THE TREATMENT OF DIABETES (U.S. CLS. 2, 5, 22, 23, 29, 37, 38 AND 50).

CLASS 42—SCIENTIFIC AND COMPUTER SERVICES

FOR MEDICAL AND SCIENTIFIC RESEARCH, NAMELY, CONDUCTING CLINICAL TRIALS AND STUDIES FOR PHARMACEUTICAL PREPARATIONS RELATED TO THE TREATMENT OF DIABETES AND PROVIDING SCIENTIFIC INFORMATION ON THE EFFICACY OF PHARMACEUTICAL PREPARATIONS FOR THE TREATMENT OF DIABETES (U.S. CLS. 100 AND 101).

CLASS 44—MEDICAL, BEAUTY AND AGRICULTURAL SERVICES

FOR PROVIDING MEDICAL INFORMATION ON THE EFFICACY OF PHARMACEUTICAL PREPARATIONS FOR THE TREATMENT OF DIABETES (U.S. CLS. 100 AND 101).

FRED CARL, EXAMINING ATTORNEY

SN 79-102,356. S.A.G. SOLARSTROM AG, FED REP GERMANY, FILED 8-1-2011.



PRIORITY DATE OF 2-2-2011 IS CLAIMED.
OWNER OF INTERNATIONAL REGISTRATION 1090179 DATED 8-1-2011, EXPIRES 8-1-2021.

NO CLAIM IS MADE TO THE EXCLUSIVE RIGHT TO USE "SOLAR" AND "ACADEMY", APART FROM THE MARK AS SHOWN.

THE COLOR(S) BLACK AND RED IS/ARE CLAIMED AS A FEATURE OF THE MARK.

THE MARK CONSISTS OF THE WORDING "SOLAR ACADEMY" IN BLACK WITH THE "OLAR" IN "SOLAR" APPEARING SMALLER THAN THE LETTER "S", AND THE "A" IN "ACADEMY" APPEARING LARGER THAN THE LETTERS "CADEMY"; ABOVE THIS WORDING IS A HORIZONTAL BLACK LINE SEPARATING THE WORDING FROM A LETTER "A" COMPRISED OF A RED CURVED BAND THAT GIVES THE IMAGE OF A RISING SUN AND SERVES AS THE HORIZONTAL BAR IN THE LETTER "A" AND THE TRIANGULAR PORTION OF THE LETTER "A" APPEARING IN BLACK AND SITTING ON THE BLACK HORIZONTAL BLACK LINE.

CLASS 35—ADVERTISING AND BUSINESS

FOR DEVELOPMENT OF MARKET ANALYSES, STUDIES AND SURVEYS (U.S. CLS. 100, 101 AND 102).

CLASS 41—EDUCATION AND ENTERTAINMENT

FOR CONDUCTING TRAINING COURSES AND SEMINARS FOR FURTHER TRAINING AND CONTINUING EDUCATION IN THE FIELD OF ALTERNATIVE ENERGY GENERATION; EDUCATIONAL SERVICES, NAMELY, CONDUCTING OF CONVENTIONS AND CONGRESSES FOR EDUCATING THE PUBLIC ABOUT RENEWABLE ENERGY; PUBLISHING PUBLICATIONS IN THE RENEWABLE ENERGY SECTOR (U.S. CLS. 100, 101 AND 107).

CLASS 42—SCIENTIFIC AND COMPUTER SERVICES

FOR RESEARCH AND DEVELOPMENT OF ENVIRONMENTALLY FRIENDLY FORMS OF ENERGY (U.S. CLS. 100 AND 101).

SHAILA SETTLES, EXAMINING ATTORNEY

SN 79-102,485. SHENZHEN JUCHANG FASHION CO., LTD., SHENZHEN, CHINA, FILED 8-2-2011.



DONG PIN LANG

PRIORITY DATE OF 4-11-2011 IS CLAIMED.
OWNER OF INTERNATIONAL REGISTRATION 1090579
DATED 8-2-2011, EXPIRES 8-2-2021.

THE MARK CONSISTS OF THE WORDING "DONG PIN LANG" AND THE LETTERS "DP" IN STYLIZED FONT.

THE ENGLISH TRANSLATION OF "DONG PIN LANG" IN THE MARK IS "EAST", "TASTE" AND "CORRIDOR".

CLASS 18—LEATHER GOODS

FOR FUR; PURSES; HANDBAGS; SCHOOL BAGS; CARRY-ON BAGS; BACKPACKS AS RUCKSACKS; SUITCASES; LEATHER STRAPS; UMBRELLAS (U.S. CLS. 1, 2, 3, 22 AND 41).

CLASS 25—CLOTHING

FOR CLOTHING, NAMELY, SHIRTS, PANTS, COATS, DRESSES, SUITS, SWEATERS, LAYETTES AND SWIM-SUITS; WEDDING DRESS; SHOES; HATS; HOSIERY; GLOVES AS CLOTHING; NECKTIES; LEATHER BELT (U.S. CLS. 22 AND 39).

WILLIAM ROSSMAN, EXAMINING ATTORNEY

SN 79-102,486. BDP SICHERHEITSTECHNOLOGIEN GMBH, AUSTRIA, FILED 6-16-2011.



THE MARK CONSISTS OF STANDARD CHARACTERS WITHOUT CLAIM TO ANY PARTICULAR FONT, STYLE, SIZE, OR COLOR.

PRIORITY DATE OF 12-20-2010 IS CLAIMED.

OWNER OF INTERNATIONAL REGISTRATION 1090585
DATED 6-16-2011, EXPIRES 6-16-2021.

THE WORDING "AIRPIRB" HAS NO MEANING IN A FOREIGN LANGUAGE.

CLASS 9—ELECTRICAL AND SCIENTIFIC APPARATUS

FOR LIFE SAVING APPARATUS AND EQUIPMENT, NAMELY, LIFE SAVING RAFTS AND LIFE BOATS; LIFE BUOYS (U.S. CLS. 21, 23, 26, 36 AND 38).

CLASS 12—VEHICLES

FOR LAND VEHICLES; AIR VEHICLES, NAMELY, AEROPLANES, HELICOPTERS, UNMANNED AERIAL VEHICLES; WATER VEHICLES, NAMELY, BOATS; MARINE VEHICLES, NAMELY, RUN-ABOUTS; HYDROFOIL BOATS SUPPORTED BY SINGLE OR MULTI HULLS, AND STRUCTURAL PARTS THEREFOR; VEHICLES, NAMELY, AMPHIBIOUS VEHICLES, CARS, ELECTRIC VEHICLES, NAMELY, ELECTRIC AUTOMOBILES; LAND VEHICLES, RAIL VEHICLES, NAMELY, TRAINS; APPARATUS FOR LOCOMOTION BY LAND, AIR OR WATER, NAMELY, AUTOMOBILES, AIRPLANES AND BOATS (U.S. CLS. 19, 21, 23, 31, 35 AND 44).

CLASS 39—TRANSPORTATION AND STORAGE

FOR RESCUE OPERATIONS; SALVAGING OF APPARATUS FOR LOCOMOTION BY LAND, AIR OR WATER (U.S. CLS. 100 AND 105).

CLASS 42—SCIENTIFIC AND COMPUTER SERVICES

FOR ELECTRONIC DATA BACK-UP SERVICES FOR COMPUTER HARD DRIVE DATA (U.S. CLS. 100 AND 101).

LYDIA BELZER, EXAMINING ATTORNEY

SN 79-103,066. SALOMON SAS, FRANCE, FILED 8-5-2011.



PRIORITY DATE OF 7-4-2011 IS CLAIMED.

OWNER OF INTERNATIONAL REGISTRATION 1092092
DATED 8-5-2011, EXPIRES 8-5-2021.

OWNER OF U.S. REG. NOS. 1,443,897, 4,021,320 AND OTHERS.

THE MARK CONSISTS OF A SQUARE WITH ROUNDED CORNERS AND THE STYLIZED LETTER "S" LOCATED INSIDE.

CLASS 9—ELECTRICAL AND SCIENTIFIC APPARATUS

FOR EYEWEAR, SUNGLASSES, SKI MASKS, HELMETS, NAMELY, SKI AND SNOWBOARDING HELMETS, MEASURING APPARATUS FOR DETERMINING SKI AND SNOWBOARD BOOT SIZE, NAMELY, INSTRUMENTS FOR MEASURING WIDTH AND LENGTH OF A USER'S FOOT (U.S. CLS. 21, 23, 26, 36 AND 38).

CLASS 18—LEATHER GOODS

FOR LUGGAGE AND BAGS OF LEATHER OR IMITATION LEATHER AND OF CLOTH, NAMELY, BACKPACKS, SHOE BAGS FOR TRAVEL, TRAVEL BAGS, HANDBAGS, BELT BAGS, SHOULDER BAGS, TENNIS BAGS, BEACH BAGS, MOUNTAIN CLIMBING BAGS, HIKING BAGS, WHEELED BAGS AND PURSES (U.S. CLS. 1, 2, 3, 22 AND 41).

CLASS 25—CLOTHING

FOR CLOTHING AND SPORTSWEAR, EXCEPT FOR DIVING, NAMELY, PANTS, SHORTS, T-SHIRTS, SWEATSHIRTS, USED FOR SKIING AND TENNIS, OVER GARMENTS, NAMELY, JACKETS, WATER-PROOF CLOTHING, NAMELY JACKETS AND PANTS, WINDPROOF CLOTHING, NAMELY, JACKETS AND PANTS, UNDERCLOTHES, GLOVES AND MITTENS, HEADGEAR, NAMELY, CAPS, BASEBALL CAPS, BELTS, SKI SUITS, PARKAS, ANORAKS, SHIRTS, POLO SHIRTS, T-SHIRTS, SWEATSHIRTS, SHORTS, SKIRTS, BERMUDA SHORTS, TANK TOPS, SLACKS, SOCKS, FOOTWEAR, SPORTS FOOTWEAR, LEISURE FOOTWEAR, TENNIS FOOTWEAR, SKI AND AFTER-SKI FOOTWEAR, HIKING FOOTWEAR, MOUNTAIN FOOTWEAR, RUNNING FOOTWEAR, BOOTS, SANDALS (U.S. CLS. 22 AND 39).

CLASS 28—TOYS AND SPORTING GOODS

FOR SPORTING ARTICLES, NAMELY, SKIS, SKI BINDINGS, SNOWBOARDS, SNOWBOARD BINDINGS, SKI POLES, SNOWSHOES, SLALOM GATES AND MARKER POLES; PROTECTIVE PADDING FOR SPORTSWEAR, NAMELY, KNEE GUARDS FOR ATHLETIC USE, ELBOW GUARDS FOR ATHLETIC USE, AND BACK PROTECTORS FOR ATHLETIC USE (U.S. CLS. 22, 23, 38 AND 50).

CLASS 35—ADVERTISING AND BUSINESS

FOR ONLINE RETAIL STORE SERVICES PROVIDED OVER A GLOBAL COMPUTER NETWORK IN THE FIELD OF SPORTS AND LEISURE CLOTHING, SPORTS ARTICLES, EYEWEAR, SUNGLASSES, SKI MASKS, PROTECTIVE HELMETS FOR SPORTS, JEWELRY ARTICLES AND TIMEPIECES, SPORTS BAGS, TRAVEL BAGS, LEISURE BAGS, BACKPACKS, PURSES, PRINTED MATTER INCLUDING MAGAZINES, DVDS, CD-ROMS, VIDEOS, DCDS, CDS AND ELECTRONIC GAMES; ADVERTISING, SAMPLE AND PROSPECTUS DISTRIBUTION (U.S. CLS. 100, 101 AND 102).

LANA PHAM, EXAMINING ATTORNEY

SN 79-103,507. DSM IP ASSETS B.V., NL-6411 TE HEERLEN, NETHERLANDS, FILED 8-31-2011.

NATUFERM

THE MARK CONSISTS OF STANDARD CHARACTERS WITHOUT CLAIM TO ANY PARTICULAR FONT, STYLE, SIZE, OR COLOR.

PRIORITY DATE OF 5-12-2011 IS CLAIMED.
OWNER OF INTERNATIONAL REGISTRATION 1093166 DATED 8-31-2011, EXPIRES 8-31-2021.

CLASS 1—CHEMICALS

FOR CHEMICALS AND BIOCHEMICALS FOR USE IN THE BEVERAGE INDUSTRY; ENZYMES AND ENZYME PREPARATIONS FOR INDUSTRIAL USE, NAMELY, ENZYMES AND ENZYME PREPARATIONS FOR USE IN THE BEVERAGE INDUSTRY, IN THE FERMENTATION INDUSTRY, AND IN THE WINE MAKING INDUSTRY; CHEMICALS AND BIOCHEMICALS FOR THE PRESERVATION OF FOOD AND DRINK; CHEMICALS AND BIOCHEMICALS FOR USE IN WINE MAKING (U.S. CLS. 1, 5, 6, 10, 26 AND 46).

CLASS 30—STAPLE FOODS

FOR YEAST; YEAST EXTRACTS; YEAST PRODUCTS, NAMELY, YEAST POWDER; FRESH AND DRIED YEAST FOR MAKING WINE (U.S. CL. 46).
RICHARD WHITE, EXAMINING ATTORNEY

SN 79-103,647. MANIFATTURA LANE GAETANO MARZOTTO & FIGLI S.P.A., ITALY, FILED 8-23-2011.



PRIORITY DATE OF 7-8-2011 IS CLAIMED.
OWNER OF INTERNATIONAL REGISTRATION 1093509 DATED 8-23-2011, EXPIRES 8-23-2021.

OWNER OF U.S. REG. NOS. 1,575,066, 1,584,751 AND 3,605,151.

NO CLAIM IS MADE TO THE EXCLUSIVE RIGHT TO USE "1836" AND "GROUP", APART FROM THE MARK AS SHOWN.

THE MARK CONSISTS OF "1836" ABOVE THE WORD "MARZOTTO", BOTH OF WHICH ARE ABOVE A HORIZONTAL LINE. BELOW THE LINE IS THE WORD "GROUP". THE YEAR "1836" AND "MARZOTTO" ARE SUPERIMPOSED ABOVE A LETTER "M" IN STYLIZED FORM.

CLASS 23—YARNS AND THREADS

FOR YARNS AND THREADS, FOR TEXTILE USE (U.S. CL. 43).

CLASS 24—FABRICS

FOR WOOL YARN FABRICS, COTTON FABRICS, SILK FABRICS, AND FLAX FABRICS; HOUSEHOLD LINENS, TRAVELING RUGS, CURTAINS, BED COVERS, FABRIC TABLE COVERS, BED BLANKETS (U.S. CLS. 42 AND 50).

CLASS 25—CLOTHING

FOR CLOTHING, NAMELY, SUITS, OVERCOATS, GREATCOATS, RAINCOATS, MANTLES, JACKETS, TROUSERS, WAISTCOATS, BLUE JEANS, SHIRTS, PULLOVERS, SWEATERS, CARDIGANS, T-SHIRTS, UNDERCLOTHES, NAMELY, UNDERSHIRTS AND UNDERPANTS, STOCKINGS, SOCKS, BELTS, TIES, SCARVES, GLOVES; FOOTWEAR; HEADGEAR, NAMELY, CAPS, HATS (U.S. CLS. 22 AND 39).
SHANNON TWOHIG, EXAMINING ATTORNEY

SN 79-103,688. GRAND MARBLE, INC., KYOTO 601-8182, JAPAN, FILED 6-10-2011.

GRAND MARBLE

PRIORITY DATE OF 12-15-2010 IS CLAIMED.
OWNER OF INTERNATIONAL REGISTRATION 1093635 DATED 6-10-2011, EXPIRES 6-10-2021.

NO CLAIM IS MADE TO THE EXCLUSIVE RIGHT TO USE "MARBLE", APART FROM THE MARK AS SHOWN.

CLASS 30—STAPLE FOODS

FOR TEA; ICED TEA; TEA-BASED BEVERAGES; TEA-BASED BEVERAGES WITH MILK; RED TEA-BASED BEVERAGES; COFFEE; ARTIFICIAL COFFEE; CHICORY BASED COFFEE SUBSTITUTE; VEGETAL PREPARATIONS FOR USE AS COFFEE SUBSTITUTES; COFFEE-BASED BEVERAGES WITH MILK; COFFEE-BASED BEVERAGES; COCOA; CHOCOLATE BEVERAGES WITH MILK; CHOCOLATE-BASED BEVERAGES; COCOA BEVERAGES WITH MILK; COCOA BEVERAGES; COCOA PRODUCTS, NAMELY, COCOA SPREADS, COCOA MIXES, COCOA POWDERS; CONFECTIONERY, NAMELY, CHOCOLATE CONFECTIONS, CONFECTIONERY MADE OF SUGAR; FROZEN CONFECTIONS; ALMOND CONFECTIONERY, NAMELY, ALMOND CAKE, SUGAR-COATED ALMONDS; BISCUITS; CAKES; CANDY FOR FOOD; CARAMELS; CHEWING GUM, NOT FOR MEDICAL PURPOSES; CHIPS, NAMELY, CHOCOLATE CHIPS, CONFECTIONERY CHIPS FOR BAKING; CHOCOLATE; CONFECTIONERY FOR DECORATING CHRISTMAS TREES; COOKIES; CRACKERS; CUSTARD; EDIBLE DECORATIONS FOR CAKES; EDIBLE ICES; FONDANTS; FROZEN YOGHURT; FRUIT JELLIES CANDY; HALVAH; ICE CREAM; LIQUORICE; NON-MEDICATED LOZENGES; MACAROONS; MALT BISCUITS; CONFECTIONERY, NAMELY, PASTILLES; PASTRIES, NAMELY, PASTY; PEANUT CONFECTIONERY, NAMELY, PEANUT BRITTLE AND PEANUT BUTTER CONFECTIONERY CHIPS; PEPPERMINT SWEETS; PETIT-BEURRE BISCUITS; PETITS FOURS; PIES; POP-CORN; PRALINES; PUDDINGS; RICE CAKES; RUSKS; SHERBETS; STICK LIQUORICE; SUGAR CONFECTIONERY, NAMELY, CONFECTIONERY MADE OF SUGAR; TARTS; TORTILLAS; WAFFLES; SHRIMP FLAVORED CRACKER; BEAN JAM BUN; DANISH PASTRY; BUNS; BREAD ROLLS; GINGER BREAD; UNLEAVENED BREAD; BREAD, NAMELY, DANISH-STYLE LOAF OF BREAD; DANISH BREADS, NAMELY, DANISH PASTRIES AND DANISH; PASTRIES; BREAD; MARZIPAN; PANCAKES; SPONGE CAKE; MOON CAKE; CONDIMENTS OTHER THAN SPICES, NAMELY, PEPPER SAUCE, CHUTNEYS, PREPARED HORSERADISH, PICKLED GINGER; PROCESSED CEREALS; BREAD-CRUMBS; CAKE PASTE, NAMELY, CHOCOLATE PASTES FOR CAKES, CAKE ICING PASTES; CEREAL PREPARATIONS, NAMELY, READY TO EAT CEREAL DERIVED FOOD BARS, CEREAL BASED SNACK FOODS, AND BISCUITS, TARTS, AND CAKES MADE WITH CEREALS; CHIPS, NAMELY, CORN CHIPS, FLOUR-BASED CHIPS, AND GRAIN-BASED CHIPS; CORN FLAKES; CORN, ROASTED; COUSCOUS; FARINACEOUS FOOD PASTES FOR HUMAN CONSUMPTION; FARINACEOUS FOODS, NAMELY, PASTA, FLOUR-BASED GNOCCHI, RICE; GRUEL, WITH A MILK BASE, FOR FOOD, NAMELY, GRITS, OATMEAL; MACARONI; NOODLES; OAT FLAKES; OAT-BASED FOOD, NAMELY, OATMEAL AND ROLLED OATS; OATMEAL; PASTA; PASTRY; RIBBON VERMICELLI; SPAGHETTI; VERMICELLI; FINE NOODLES; INSTANT NOODLES; SPRING ROLL WRAPPER, NAMELY, WON TON WRAPPERS, PHYLLO DOUGH; RICE NOODLES; CRISPY RICE, NAMELY, RICE CAKES, RICE CRACKERS; CHINESE STUFFED DUMPLINGS (GYOZA, COOKED); SANDWICHES; CHINESE STEAMED DUMPLINGS (SHUMAI, COOKED); SUSHI; DUMPLINGS, NAMELY, FRIED BALLS OF BATTER MIX WITH SMALL PIECES OF OCTOPUS; STEAMED BUNS STUFFED WITH MINCED MEAT; SANDWICHES, NAMELY, HAMBURGERS; PIZZAS; PREPARED BOXED LUNCHES CONSISTING PRIMARILY OF RICE WITH ADDED MEAT, FISH OR VEGETABLES; SANDWICHES, NAMELY, HOT DOGS; MEAT PIES; RAVIOLI; QUICHES; SPRING ROLLS; TACOS; FRIED RICE; DUMPLINGS, NAMELY, CHINESE RICE DUMPLINGS WRAPPED IN BAMBOO OR REED LEAVES; YEAST POWDER; RICE, NAMELY, FERMENTED MALTED RICE; YEAST; FERMENTS FOR PASTES, NAMELY, YEAST EXTRACTS FOR FOOD; YEAST IN PILL FORM, NOT FOR MEDICAL USE; BAKING POWDER; LEAVEN, NAMELY, FOOD LEAVENING AGENTS (U.S. CL. 46).

CLASS 43—HOTEL AND RESTAURANT SERVICES

FOR PROVIDING TEMPORARY HOUSING ACCOMMODATION; PROVIDING FOODS AND BEVERAGES; BAR SERVICES; CAFES; CAFETERIAS; CANTEN SERVICES; FOOD AND DRINK CATERING; RESTAURANTS; SELF-SERVICE RESTAURANTS; SNACK-BARS; TEA HOUSE, NAMELY, TEA BARS AND TEA ROOMS (U.S. CLS. 100 AND 101).

MARK SHINER, EXAMINING ATTORNEY

SN 79-103,689. GRAND MARBLE, INC., JAPAN, FILED 6-10-2011.



PRIORITY DATE OF 12-15-2010 IS CLAIMED.
OWNER OF INTERNATIONAL REGISTRATION 1093636
DATED 6-10-2011, EXPIRES 6-10-2021.

CLASS 30—STAPLE FOODS

FOR TEA; ICED TEA; TEA-BASED BEVERAGES; TEA-BASED BEVERAGES WITH MILK; RED TEA-BASED BEVERAGES; COFFEE; ARTIFICIAL COFFEE; CHICORY BASED COFFEE SUBSTITUTE; VEGETAL PREPARATIONS FOR USE AS COFFEE SUBSTITUTES; COFFEE-BASED BEVERAGES WITH MILK; COFFEE-BASED BEVERAGES; COCOA; CHOCOLATE BEVERAGES WITH MILK; CHOCOLATE-BASED BEVERAGES; COCOA BEVERAGES WITH MILK; COCOA BEVERAGES; COCOA PRODUCTS, NAMELY, COCOA SPREADS, COCOA MIXES, COCOA POWDERS; CONFECTIONERY, NAMELY, CHOCOLATE CONFECTIONS, CONFECTIONERY MADE OF SUGAR; FROZEN CONFECTIONS; ALMOND CONFECTIONERY, NAMELY, ALMOND CAKE, SUGAR-COATED ALMONDS; BISCUITS; CAKES; CANDY FOR FOOD; CARAMELS; CHEWING GUM, NOT FOR MEDICAL PURPOSES; CHIPS, NAMELY, CHOCOLATE CHIPS, CONFECTIONERY CHIPS FOR BAKING; CHOCOLATE; CONFECTIONERY FOR DECORATING CHRISTMAS TREES; COOKIES; CRACKERS; CUSTARD; EDIBLE DECORATIONS FOR CAKES; EDIBLE ICES; FONDANTS; FROZEN YOGHURT; FRUIT JELLIES CANDY; HALVAH; ICE CREAM; LIQUORICE; NON-MEDICATED LOZENGES; MACAROONS; MALT BISCUITS; CONFECTIONERY, NAMELY, PASTILLES; PASTRIES, NAMELY, PASTY; PEANUT CONFECTIONERY, NAMELY, PEANUT BRITTLE AND PEANUT BUTTER CONFECTIONERY CHIPS; PEPPERMINT SWEETS; PETIT-BEURRE BISCUITS; PETITS FOURS; PIES; POP-CORN; PRALINES; PUDDINGS; RICE CAKES; RUSKS; SHERBETS; STICK LIQUORICE; SUGAR CONFECTIONERY, NAMELY, CONFECTIONERY MADE OF SUGAR; TARTS; TORTILLAS; WAFFLES; SHRIMP FLAVORED CRACKER; BEAN JAM BUN; DANISH PASTRY; BUNS; BREAD ROLLS; GINGER BREAD; UNLEAVENED BREAD; BREAD, NAMELY, DANISH-STYLE LOAF OF BREAD; DANISH BREADS, NAMELY, DANISH PASTRIES AND DANISH; PASTRIES; BREAD; MARZIPAN; PANCAKES; SPONGE CAKE; MOON CAKE; CONDIMENTS OTHER THAN SPICES, NAMELY, PEPPER SAUCE, CHUTNEYS, PREPARED HORSERADISH, PICKLED GINGER; PROCESSED CEREALS; BREAD-CRUMBS; CAKE PASTE, NAMELY, CHOCOLATE PASTES FOR CAKES, CAKE ICING PASTES; CEREAL PREPARATIONS, NAMELY, READY TO EAT CEREAL DERIVED FOOD BARS, CEREAL BASED SNACK FOODS, AND BISCUITS, TARTS, AND CAKES MADE

WITH CEREALS; CHIPS, NAMELY, CORN CHIPS, FLOUR-BASED CHIPS, AND GRAIN-BASED CHIPS; CORN FLAKES; CORN, ROASTED; COUSCOUS; FARINACEOUS FOOD PASTES FOR HUMAN CONSUMPTION; FARINACEOUS FOODS, NAMELY, PASTA, FLOUR-BASED GNOCCHI, RICE; GRUEL, WITH A MILK BASE, FOR FOOD, NAMELY, GRITS, OATMEAL; MACARONI; NOODLES; OAT FLAKES; OAT-BASED FOOD, NAMELY, OATMEAL AND ROLLED OATS; OATMEAL; PASTA; PASTRY; RIBBON VERMICELLI; SPAGHETTI; VERMICELLI; FINE NOODLES; INSTANT NOODLES; SPRING ROLL WRAPPER, NAMELY, WONTON WRAPPERS, PHYLLO DOUGH; RICE NOODLES; CRISPY RICE, NAMELY, RICE CAKES, RICE CRACKERS; CHINESE STUFFED DUMPLINGS (GYOZA, COOKED); SANDWICHES; CHINESE STEAMED DUMPLINGS (SHUMAI, COOKED); SUSHI; DUMPLINGS, NAMELY, FRIED BALLS OF BATTER MIX WITH SMALL PIECES OF OCTOPUS; STEAMED BUNS STUFFED WITH MINCED MEAT; SANDWICHES, NAMELY, HAMBURGERS; PIZZAS; PREPARED BOXED LUNCHES CONSISTING PRIMARILY OF RICE WITH ADDED MEAT FISH OR VEGETABLES; SANDWICHES, NAMELY, HOT DOGS; MEAT PIES; RAVIOLI; QUICHES; SPRING ROLLS; TACOS; FRIED RICE; DUMPLINGS, NAMELY, CHINESE RICE DUMPLINGS WRAPPED IN BAMBOO OR REED LEAVES; YEAST POWDER; RICE, NAMELY, FERMENTED MALTED RICE; YEAST; FERMENTS FOR PASTES, NAMELY, YEAST EXTRACTS FOR FOOD; YEAST IN PILL FORM, NOT FOR MEDICAL USE; BAKING POWDER; LEAVEN, NAMELY, FOOD LEAVENING AGENTS (U.S. CL. 46).

CLASS 43—HOTEL AND RESTAURANT SERVICES

FOR PROVIDING TEMPORARY HOUSING ACCOMMODATION; PROVIDING FOODS AND BEVERAGES; BAR SERVICES; CAFES; CAFETERIAS; CANTEN SERVICES; FOOD AND DRINK CATERING; RESTAURANTS; SELF-SERVICE RESTAURANTS; SNACK-BARS; TEA HOUSE, NAMELY TEA BARS AND TEA ROOMS (U.S. CLS. 100 AND 101).

MARK SHINER, EXAMINING ATTORNEY

SN 79-103,692. JETION SOLAR (EUROPE) LTD., LIECHTENSTEIN, FILED 5-10-2011.

FullCycle PV

THE MARK CONSISTS OF STANDARD CHARACTERS WITHOUT CLAIM TO ANY PARTICULAR FONT, STYLE, SIZE, OR COLOR.

PRIORITY DATE OF 11-23-2010 IS CLAIMED.

OWNER OF INTERNATIONAL REGISTRATION 1093642 DATED 5-10-2011, EXPIRES 5-10-2021.

NO CLAIM IS MADE TO THE EXCLUSIVE RIGHT TO USE "PV", APART FROM THE MARK AS SHOWN.

CLASS 9—ELECTRICAL AND SCIENTIFIC APPARATUS

FOR PHOTOVOLTAIC CELLS FOR ELECTRICITY GENERATION; PHOTOVOLTAIC CELLS ALSO INCLUDING A SOLAR THERMAL COLLECTOR SOLD AS A UNIT; PHOTOVOLTAIC SOLAR MODULES FOR ELECTRICITY GENERATION; PHOTOVOLTAIC CELLS FOR SOLAR COLLECTORS; SOLAR BATTERIES (U.S. CLS. 21, 23, 26, 36 AND 38).

CLASS 19—NON-METALLIC BUILDING MATERIALS

FOR NON-METAL ROOFS WITH INTEGRATED SOLAR CELLS (U.S. CLS. 1, 12, 33 AND 50).

CLASS 35—ADVERTISING AND BUSINESS

FOR RETAIL AND WHOLESALE STORE SERVICES FEATURING ROOFS WITH INTEGRATED SOLAR CELLS, SOLAR COLLECTORS AND MODULES FOR POWER GENERATION, SOLAR COLLECTORS AND MODULES FOR HEAT GENERATION, SOLAR BATTERIES, AND COMPONENTS FOR COLLECTORS AND MODULES OF THIS KIND; ARRANGING OF BUYING AND SELLING CONTRACTS FOR THIRD PARTIES WITH ELECTRICITY SUPPLIERS; ARRANGING CONTRACTS FOR OTHERS FOR THE BUYING AND SELLING OF COLLECTORS AND MODULES USED FOR ELECTRICITY GENERATION, HEAT GENERATION AND SOLAR FARMS (U.S. CLS. 100, 101 AND 102).

CLASS 37—CONSTRUCTION AND REPAIR

FOR INSTALLATION AND MAINTENANCE OF SOLAR INSTALLATIONS; CONSTRUCTION MANAGEMENT FOR SOLAR INSTALLATIONS AND SOLAR FARMS (U.S. CLS. 100, 103 AND 106).

ELLEN B. AWRICH, EXAMINING ATTORNEY

SN 79-104,024. SESDERMA, S.L., SPAIN, FILED 6-8-2011.

SES MENOSES

THE MARK CONSISTS OF STANDARD CHARACTERS WITHOUT CLAIM TO ANY PARTICULAR FONT, STYLE, SIZE, OR COLOR.

OWNER OF INTERNATIONAL REGISTRATION 1094509 DATED 6-8-2011, EXPIRES 6-8-2021.

OWNER OF U.S. REG. NOS. 2,483,289 AND 3,480,421.

CLASS 3—COSMETICS AND CLEANING PREPARATIONS

FOR COSMETICS; COSMETIC PREPARATIONS FOR SKIN CARE (U.S. CLS. 1, 4, 6, 50, 51 AND 52).

CLASS 5—PHARMACEUTICALS

FOR PHARMACEUTICAL PREPARATIONS FOR SKIN CARE; AND DIETETIC FOODS ADAPTED FOR MEDICAL USE (U.S. CLS. 6, 18, 44, 46, 51 AND 52).

PATRICIA EVANKO, EXAMINING ATTORNEY

SN 79-105,185. NIMCO SCHOENBEDRIJVEN B.V., NETHERLANDS, FILED 9-1-2011.



PRIORITY DATE OF 4-20-2011 IS CLAIMED.

OWNER OF INTERNATIONAL REGISTRATION 1097097 DATED 9-1-2011, EXPIRES 9-1-2021.

OWNER OF U.S. REG. NO. 3,776,803.

NO CLAIM IS MADE TO THE EXCLUSIVE RIGHT TO USE "STRETCHWALKER", APART FROM THE MARK AS SHOWN.

THE MARK CONSISTS OF THE WORD "STRETCHWALKER" TO THE RIGHT OF A DESIGN OF TWO SHOE SOLES.

CLASS 10—MEDICAL APPARATUS

FOR ORTHOPEDIC FOOTWEAR (U.S. CLS. 26, 39 AND 44).

CLASS 25—CLOTHING

FOR FOOTWEAR (U.S. CLS. 22 AND 39).
MICHAEL SOUDERS, EXAMINING ATTORNEY

SN 79-105,681. DANIELLE ROCHES, FRANCE, FILED 10-24-2011.

YOUTH REANIMATION

PRIORITY DATE OF 5-27-2011 IS CLAIMED.
OWNER OF INTERNATIONAL REGISTRATION 1098113
DATED 10-24-2011, EXPIRES 10-24-2021.

CLASS 3—COSMETICS AND CLEANING PREPARATIONS

FOR SOAP; PERFUMES, ESSENTIAL OILS, COSMETICS, HAIR LOTIONS; MAKE-UP REMOVING PRODUCTS; LIPSTICKS; BEAUTY MASKS (U.S. CLS. 1, 4, 6, 50, 51 AND 52).

CLASS 44—MEDICAL, BEAUTY AND AGRICULTURAL SERVICES

FOR HYGIENIC AND BEAUTY CARE FOR HUMAN BEINGS OR ANIMALS (U.S. CLS. 100 AND 101).
TOBY BULLOFF, EXAMINING ATTORNEY

SN 79-107,279. FABRIZIO ALIERI, ITALY, FILED 6-29-2011.



PRIORITY DATE OF 12-31-2010 IS CLAIMED.
OWNER OF INTERNATIONAL REGISTRATION 1101936
DATED 6-29-2011, EXPIRES 6-29-2021.

THE MARK CONSISTS OF A DESIGN OF A SQUARE WITH ROUNDED EDGES CONTAINING A DESIGN OF AN AIRPLANE.

CLASS 3—COSMETICS AND CLEANING PREPARATIONS

FOR SKIN SOAPS, DEODORANT SOAPS; PERFUMERIES, NAMELY, PERFUME, COLOGNE; COSMETICS, NAMELY, LIPSTICK, BLUSH, ROUGE, MAKEUP; HAIR CARE PRODUCTS, NAMELY, SHAMPOO, CONDITIONER, HAIR GEL; SKIN CARE AND BODY CARE PRODUCTS, NAMELY, SKIN CREAM, SKIN CONDITIONER, BODY MASKS, BODY OILS, BODY POWDER, DENTIFRICES, PRE-MOISTENED COSMETIC TISSUES; COSMETIC PRODUCTS IN THE FORM OF AEROSOLS FOR SKIN CARE (U.S. CLS. 1, 4, 6, 50, 51 AND 52).

CLASS 9—ELECTRICAL AND SCIENTIFIC APPARATUS

FOR MAGNETIC DATA MEDIA, NAMELY, BLANK MAGNETIC DISCS AND DATA CARRIERS, BLANK CD-ROMS, BLANK ELECTRONIC SMART CARDS; PLASTIC BARCODE LABELS; BAR CODE LABELS; MAGNETICALLY ENCODED DEBIT CARDS, BANK CARDS, CREDIT CARDS, PRE-PAYMENT CARDS, DISCOUNT CARDS AND PAYMENT CARDS; ELECTRONIC VERIFICATION APPARATUS IN THE NATURE OF COMPUTER HARDWARE AND SCANNERS FOR AUTHENTICATION OF DEBIT CARDS, BANK CARDS, PRE-PAYMENT CARDS AND DISCOUNT CARDS; COMPUTER SOFTWARE FOR ENCRYPTION; COMPUTER SOFTWARE ENABLING SMART CARDS TO CONNECT AND INTERFACE WITH COMPUTER TERMINALS AND CARD READERS; AUTOMATIC VENDING MACHINES AND MECHANISMS FOR COIN-OPERATED APPARATUS THAT DISPENSE FOOD, DRINKS, TOYS, NOVELTY ITEMS, LOTTERY TICKETS, SOUVENIRS; ELECTRONIC APPARATUS, NAMELY, CARD READERS FOR MAGNETICALLY ENCODED CARDS; BLANK ELECTRONIC CHIP CARDS; ELECTRIC AND ELECTRONIC APPARATUS IN THE NATURE OF COMPUTER HARDWARE AND DATA PROCESSORS FOR PROCESSING CONNECTING, STORING TRANSMITTING, RECOVERING AND RECEIVING DATA; DISTANCE WRITING AND RETRIEVING APPARATUS, NAMELY, RFID READERS AND RFID WRITERS, RFID CHIPS AND ANTENNAS; PRINTED HOLOGRAMS (U.S. CLS. 21, 23, 26, 36 AND 38).

CLASS 16—PAPER GOODS AND PRINTED MATTER

FOR ADDRESS LABELS; TEAR-OFF PAPER LABELS; PLASTIC LABELS; BLANK PLASTIC ADHESIVE LABELS; ADHESIVE BANDS FOR STATIONERY OR HOUSEHOLD PURPOSES; ADHESIVE NOTE PADS; ADHESIVES FOR STATIONERY AND HOUSEHOLD USE; GLUE FOR STATIONERY OR HOUSEHOLD PURPOSES; GLUES FOR OFFICE USE; STICKERS AND IRON-ON AND PLASTIC TRANSFERS; PAINT STICK MARKERS; DECALCOMANIAS; INK STAMPS; NUMBERING STAMPS; NOTE BOOKS; NOTE PAPERS; MEMO PADS; ILLUSTRATED NOTEPADS; PRINTING PAPER; DIGITAL PRINTING PAPER; LABEL PAPER; PRINTED PAPER LABELS; LAMINATED PAPER; PLASTIC COATED COPYING PAPER; LETTERHEAD PAPER; ADVERTISING PAMPHLETS; ADVERTISING SIGNS OF PAPER OR CARDBOARD; BANNERS OF PAPER; CARDBOARDS; COUPONS; PRE-CUT CARDS NOT MAGNETICALLY CODED FOR USE IN BUSINESS TRANSACTIONS; CARDS, NAMELY, DISCOUNT CARDS, VOUCHER CARDS, NOTE CARDS, BUSINESS CARDS, TRADING CARDS, CREDIT CARDS, DEBIT CARDS, PROMOTIONAL CARDS, PERFORATED CARDS, VOUCHER CARDS, REDEEMABLE CARDS, FIDELITY CARDS, ALL WITHOUT MAGNETIC CODING; PENS; GEL ROLLER PENS; BALLPOINT PENS; PENCILS; COLOR PENCILS; CRAYONS; PENCIL CASES AND BOXES; BINDING MATERIALS FOR BOOKS AND PAPERS; BOOKMARKERS; BOXES OF CARDBOARD OR PAPER; STORAGE CONTAINERS MADE OF PAPER; PACKING CARDBOARD; PAPER AND CARDBOARD; COLORBOARD; CELLOPHANE PAPER; PAPER AND CARTON SEALING TAPE; PAPER LABELS; PAPER FOR USE IN THE MANUFACTURE OF BAGS, SACS POUCHES AND ENVELOPES; PAPER IDENTIFICATION TAGS; PAPER STATIONERY; OFFICE STATIONERY; COVERS OF PAPER FOR PACKAGING; BOOK COVERS; PROTECTIVE COVERS MADE OF PLASTIC OR CARD-

BOARDS; FOLDERS FOR LETTERS; DOCUMENT COVERS; DOCUMENT FOLDERS IN THE FORM OF WALLS; COLLECTOR'S PHOTOGRAPHS OF PLAYERS; CORRUGATED BOARD AND PAPER CONTAINERS; HAND TOWELS OF PAPER; HANDKERCHIEFS OF PAPER; DATE STAMPS; DESK CALENDARS; ENGRAVINGS AND THEIR REPRODUCTIONS; GRAPHIC PRINTS AND REPRESENTATIONS; EMBROIDERY DESIGN PATTERNS PRINTED ON PAPER; GREETINGS CARDS AND POSTCARDS; ENTRY TICKETS; PASSENGER TICKETS; INFLIGHT MAGAZINES; BULLETIN BOARDS; NEWSPAPERS; PLASTIC BAGS FOR PACKAGING; PLASTIC OR PAPER BAGS FOR MERCHANDISE PACKAGING; PLASTIC ENVELOPES; PLASTIC POUCHES; PLASTIC PAGES FOR HOLDING LABELS, COUPONS, RECEIPTS, TRADING CARDS, VOUCHERS; PLASTIC FOILS; PLASTIC SHEETS FOR WRITING, PRINTING AND MARKING; PLASTIC TRANSPARENCIES; BROCHURES ABOUT TELECOMMUNICATIONS, INFORMATION TECHNOLOGY, SAFETY, NEWS, SPORTS, ENTERTAINMENT, CULTURE, BUSINESS AND FINANCE, WEATHER TRAVEL AND SHOPPING; EDUCATIONAL PUBLICATIONS IN THE FIELDS OF TELECOMMUNICATIONS, INFORMATION TECHNOLOGY, SAFETY, NEWS, SPORTS, ENTERTAINMENT, CULTURE, BUSINESS AND FINANCE, WEATHER TRAVEL AND SHOPPING, NAMELY, EDUCATIONAL LEARNING CARDS, FLASH CARDS, ACTIVITY CARDS, WORKBOOKS, TEXTBOOKS, ACTIVITY BOOKS, STORY BOOKS, PUZZLE BOOKS, PUZZLES, TEACHER GUIDES, MANUALS, POSTERS, COUPONS, HAND-OUTS, EDUCATIONAL CARD GAMES AND EDUCATIONAL BOOKLETS, GUIDE BOOKS, INFORMATIONAL FLYERS, PRINTED INFORMATIONAL CARDS, PRINTED PERIODICALS, CATALOGS ALL IN THE FIELDS OF TELECOMMUNICATIONS, INFORMATION TECHNOLOGY, SAFETY, NEWS, SPORTS, ENTERTAINMENT, CULTURE, BUSINESS AND FINANCE, WEATHER TRAVEL AND SHOPPING (U.S. CLS. 2, 5, 22, 23, 29, 37, 38 AND 50).

CLASS 18—LEATHER GOODS

FOR BACKPACKS; BOOK BAGS; SPORTS BAGS; WALLETS; KEY CASES; WALLETS WITH CARD COMPARTMENTS; HANDBAGS; POUCHES; PURSES; BUSINESS CARD CASES; CARRY-ALL BAGS; CARRYING CASES; CARRYING CASES FOR DOCUMENTS; COSMETIC BAGS AND CASES SOLD EMPTY; FOLDING BRIEFCASES; LEATHER AND IMITATION LEATHER BAGS; MULTI-PURPOSE PURSES; UMBRELLAS AND PARASOLS; SMALL SUITCASES; TRAVEL CASES (U.S. CLS. 1, 2, 3, 22 AND 41).

CLASS 21—HOUSEWARES AND GLASS

FOR DRINKING GLASSES; COFFEE CUPS, TEA CUPS AND MUGS, TEAPOTS AND WHISTLING KETTLES; TABLEWARE, NAMELY, COFFEE AND TEA SERVICES; CUPS AND PLATES OF PAPER OR PLASTIC, CERAMIC PLATES; GLASSWARE, GLASS DISHES, GLASS CARAFES; CORKSCREWS; DRINKING FLASKS FOR TRAVELERS; LUNCH BOXES; LIQUEUR SETS COMPRISED OF BOTTLE OPENERS, DRINKING GLASSES; ISOTHERMIC BAGS, NAMELY, THERMAL INSULATED BAGS FOR FOOD OR BEVERAGES; UPRIGHT SIGNBOARDS OF PORCELAIN OR GLASS; CANDLESTICKS NOT OF PRECIOUS METAL; PERFUME BURNERS; PERFUME SPRAYERS; PERFUME VAPORIZERS; APPLIANCES FOR REMOVING MAKE-UP; COSMETIC UTENSILS, NAMELY, BRUSHES, NON-WOVEN FABRIC COSMETIC WIPES; COSMETIC BRUSHES; HAIR, NAIL AND TOOTH BRUSHES; EYEBROW BRUSHES; COMBS; MANUAL TOOTHBRUSHES; ELECTRIC TOOTHBRUSHES; TOOTHBRUSHES CASES; SHAVING BRUSH STANDS; SHAVING BRUSHES; SOAP BOXES; SOAP DISPENSERS; SOAP HOLDERS; SHOE BRUSHES (U.S. CLS. 2, 13, 23, 29, 30, 33, 40 AND 50).

CLASS 25—CLOTHING

FOR HEADGEAR, NAMELY, CAPS, BASEBALL CAPS, CAP VISORS; CLOTHING, NAMELY, SHORT-SLEEVED OR LONG-SLEEVED T-SHIRTS, SHIRTS; CLOTHING MADE OF ARTIFICIAL LEATHER, NAMELY, JACKETS AND HEADWEAR; CLOTHING OF LEATHER, NAMELY, JACKETS AND HEADWEAR; WATERPROOF JACKETS AND PANTS; BEACHWEAR, BATHING COSTUMES; BEACH FOOTWEAR (U.S. CLS. 22 AND 39).

CLASS 32—LIGHT BEVERAGES

FOR SODA WATER, NAMELY, AERATED WATER; MINERAL AND CARBONATED WATERS; FLAVORED MINERAL WATER; ALCOHOL FREE APERITIFS; CONCENTRATED FRUIT JUICE; FRUIT BEVERAGES AND VEGETABLE JUICE BEVERAGES; FROZEN FRUIT-BASED BEVERAGES; NON-ALCOHOLIC COCKTAILS; COLAS; ISOTONIC BEVERAGES; BEER; TISANES IN THE NATURE OF NON-MEDICATED NON-TEA BASED BEVERAGES (U.S. CLS. 45, 46 AND 48).

CLASS 35—ADVERTISING AND BUSINESS

FOR ADVERTISING AND PUBLICITY SERVICES, NAMELY, PROMOTING THE GOODS, SERVICES, BRAND IDENTITY AND COMMERCIAL INFORMATION AND NEWS OF THIRD PARTIES THROUGH PRINT, AUDIO, VIDEO, DIGITAL AND ON-LINE MEDIUM; SERVICES COMPRISING THE RECORDING, TRANSCRIPTION, COMPOSITION, COMPILATION AND SYSTEMATIZATION OF WRITTEN COMMUNICATIONS AND RECORDINGS, AS WELL AS THE COMPI- LATION OF MATHEMATICAL OR STATISTICAL DATA; ADVERTISING, INCLUDING PROMOTION RELATING TO THE SALE OF ARTICLES AND SERVICES FOR THIRD PARTIES BY THE DISTRIBUTION OF ADVERTISING MATERIAL AND THE DISSEMINATION OF ADVERTISING MESSAGES ON COMPUTER NETWORKS; ADVERTISING AND COMMERCIAL INFORMATION SERVICES, VIA THE INTERNET; ADVERTISING SERVICES, NAMELY, PROVIDING ADVERTISING SPACE IN A PERIODICAL; ADMINISTRATION OF A DISCOUNT PROGRAM FOR ENABLING PARTICIPANTS TO OBTAIN DISCOUNTS ON GOODS AND SERVICES THROUGH USE OF DISCOUNT MEMBERSHIP CARDS AND COUPONS; PROMOTING THE GOODS AND SERVICES OF OTHERS THROUGH THE DISTRIBUTION OF DISCOUNT CARDS; PROMOTING THE GOODS AND SERVICES OF OTHERS BY PROVIDING A WEBSITE FEATURING COUPONS, REBATES, PRICE COMPARISON INFORMATION, PRODUCT REVIEWS, LINKS TO THE RETAIL WEBSITES OF OTHERS, AND DISCOUNT INFORMATION; COMPUTERIZED ON-LINE ORDERING FEATURING GENERAL MERCHANDISE AND GENERAL CONSUMER GOODS; BUSINESS INTERMEDIARY AND ADVISORY SERVICES IN THE FIELD OF SELLING PRODUCTS AND RENDERING SERVICES; COMMERCIAL ADMINISTRATION OF THE LICENSING OF THE GOODS AND SERVICES OF OTHERS; COMMERCIAL INFORMATION AND ADVICE FOR CONSUMERS, NAMELY, CONSUMER ADVICE SHOP; COMPILATION AND SYSTEMIZATION OF INFORMATION INTO COMPUTER DATABASES; COMPUTERIZED ON-LINE ORDERING SERVICES IN THE FIELD OF ADVERTISING AND SHOPPING INFORMATION IN BUSINESS MATTERS; DEVELOPMENT OF CONCEPTS FOR BUSINESS ECONOMY; CONSULTING SERVICES RELATING TO PUBLICITY; DEVELOPING PROMOTIONAL CAMPAIGNS FOR BUSINESS; CREATING, UPDATING, AND PLACING OF ADVERTISING MATERIAL; ISSUING AND UPDATING OF ADVERTISING TEXTS; DISSEMINATION OF ADVERTISING MATTER; DISTRIBUTION AND DISSEMINATION OF ADVERTISING MATERIALS, NAMELY, LEAFLETS, PROSPECTUSES, PRINTED MATERIAL, SAMPLES; DISTRIBUTION OF ADVERTISEMENTS AND COMMERCIAL ANNOUNCEMENTS; DISTRIBUTION OF PRODUCTS FOR ADVERTISING PURPOSES; DISSEMINATION OF ADVERTISING FOR OTHERS VIA THE INTERNET; ELECTRONIC BILLBOARD ADVERTISING; ON-LINE ADVERTISING ON COMPUTER COMMUNICATION NETWORKS; PROVISION OF ADVERTISING SPACE BY ELECTRONIC MEANS AND GLOBAL INFORMATION NETWORKS; INVOICING SERVICES IN THE FIELD OF ADVERTISING; ORGANISATION AND CONDUCTING OF PRODUCT PRESENTATIONS; ELEC-

TRONIC COMMERCE SERVICES, NAMELY, PROVIDING INFORMATION ABOUT PRODUCTS VIA TELECOMMUNICATION NETWORKS FOR ADVERTISING AND SALES PURPOSES; INVENTORYING MERCHANDISE; ISSUING OF DISCOUNT CERTIFICATES; NEGOTIATION AND CONCLUSION OF COMMERCIAL TRANSACTIONS FOR THIRD PARTIES VIA TELECOMMUNICATION SYSTEMS; ONLINE BUYERS GUIDE SERVICE PROVIDING INFORMATION IN THE FIELD OF TELECOMMUNICATIONS, INFORMATION TECHNOLOGY, SAFETY, NEWS, SPORTS, ENTERTAINMENT, CULTURE, BUSINESS AND FINANCE, WEATHER TRAVEL AND SHOPPING; PROMOTING THE GOODS AND SERVICES OF OTHERS THROUGH THE DISTRIBUTION OF DISCOUNT CARDS AND REDEEMABLE VOUCHERS; PROCESSING MANUFACTURER'S REBATES; PROCESSING MANUFACTURER'S COUPONS; PROMOTING THE SALE OF GOODS AND SERVICES OF OTHERS THROUGH THE DISTRIBUTION OF PRINTED MATERIAL; PROMOTING THE GOODS AND SERVICES OF OTHERS BY ARRANGING FOR SPONSORS TO AFFILIATE THEIR GOODS AND SERVICES WITH AN AWARDS PROGRAM; PROMOTION, ADVERTISING AND MARKETING OF ON-LINE WEBSITES; PROVIDING A WEB SITE WHICH FEATURES ADVERTISEMENTS FOR THE GOODS AND SERVICES OF OTHERS ON A GLOBAL COMPUTER NETWORK; PROVIDING BUSINESS INFORMATION, ALSO VIA INTERNET AND THE CABLE NETWORK; PROVIDING AN ON-LINE COMMERCIAL INFORMATION DIRECTORY ON THE INTERNET; PROVIDING INFORMATION ABOUT COMMERCIAL BUSINESS AND COMMERCIAL INFORMATION VIA THE GLOBAL COMPUTER NETWORK OR OTHER FORMS OF DATA TRANSFER; SPONSORSHIP SEARCH (U.S. CLS. 100, 101 AND 102).

ERNEST SHOSHO, EXAMINING ATTORNEY

SN 79-108,296. WOLFORD AKTIENGESELLSCHAFT, AUSTRIA, FILED 10-17-2011.

LEGCESSORIES

THE MARK CONSISTS OF STANDARD CHARACTERS WITHOUT CLAIM TO ANY PARTICULAR FONT, STYLE, SIZE, OR COLOR.

PRIORITY DATE OF 6-15-2011 IS CLAIMED.

OWNER OF INTERNATIONAL REGISTRATION 1104584 DATED 10-17-2011, EXPIRES 10-17-2021.

CLASS 25—CLOTHING

FOR LEGGINGS, HOSIERY (U.S. CLS. 22 AND 39).

CLASS 26—FANCY GOODS

FOR RIBBONS, FRINGES, LACES (U.S. CLS. 37, 39, 40, 42 AND 50).

KELLY TRUSILO, EXAMINING ATTORNEY

SN 79-975,068. GESSI S.P.A., ITALY, FILED 1-13-2011.

ISPA

THE MARK CONSISTS OF STANDARD CHARACTERS WITHOUT CLAIM TO ANY PARTICULAR FONT, STYLE, SIZE, OR COLOR.

PRIORITY DATE OF 7-22-2010 IS CLAIMED.

OWNER OF INTERNATIONAL REGISTRATION 1068839 DATED 1-13-2011, EXPIRES 1-13-2021.

CLASS 20—FURNITURE AND ARTICLES NOT OTHERWISE CLASSIFIED

FOR MIRRORS, NON-METAL CLOTHES HOOKS (U.S. CLS. 2, 13, 22, 25, 32 AND 50).

CLASS 21—HOUSEWARES AND GLASS

FOR BATHROOM ACCESSORIES, NAMELY, SOAP DISHES, SOAP DISPENSERS, LIQUID SOAP DISPENSERS, WALL-MOUNTED SOAP DISPENSERS, FREE-STANDING TOILET BRUSH HOLDERS, WALL-MOUNTED TOILET BRUSH HOLDERS, TOWEL RAILS AND RINGS, TOOTHBRUSH HOLDERS, TOILET PAPER DISPENSERS, TOILET BRUSHES, BATHROOM SPONGES; HOUSEWARE ITEMS, NAMELY, DISPENSERS FOR PAPER TOWELS (U.S. CLS. 2, 13, 23, 29, 30, 33, 40 AND 50).

SARA BENJAMIN, EXAMINING ATTORNEY

SN 85-008,348. ACCURISTIX INC., OAKVILLE, ONTARIO, CANADA, FILED 4-7-2010.

ADVANCING HEALTHCARE LOGISTICS

THE MARK CONSISTS OF STANDARD CHARACTERS WITHOUT CLAIM TO ANY PARTICULAR FONT, STYLE, SIZE, OR COLOR.

PRIORITY CLAIMED UNDER SEC. 44(D) ON CANADA APPLICATION NO. 1474687, FILED 3-26-2010.

NO CLAIM IS MADE TO THE EXCLUSIVE RIGHT TO USE "HEALTHCARE LOGISTICS", APART FROM THE MARK AS SHOWN.

CLASS 35—ADVERTISING AND BUSINESS

FOR THIRD PARTY LOGISTICS SERVICES PROVIDED TO HEALTHCARE MANUFACTURERS OR HEALTHCARE PRODUCT OWNERS, NAMELY, SUPPLY CHAIN DISTRIBUTION MANAGEMENT, ORDER MANAGEMENT AND CUSTOMER SERVICE, ORDER FULFILLMENT, PROVIDING A GUARANTEED PRICING PROGRAM AND ASSISTING WITH THE FORMATION, NEGOTIATION, AND MANAGEMENT OF CONTRACTS WITH PUBLIC SECTOR ENTITIES, INVOICING, ACCOUNTS RECEIVABLES MANAGEMENT, RETURNS AND RECALL MANAGEMENT, NAMELY, MANAGEMENT OF RECALLED MERCHANDISE AND TRANSPORTATION MANAGEMENT SERVICES, NAMELY, PLANNING AND COORDINATING TRANSPORTATION OF GOODS FOR OTHERS, ALL OF THE FOREGOING IN THE FIELDS OF HEALTHCARE, PHARMACEUTICALS, NARCOTICS AND CONTROLLED SUBSTANCES, BIOTECHNOLOGY, BIOPHARMACEUTICALS, NUTRITIONAL HEALTH PRODUCTS, DIAGNOSTIC, LABORATORY, MEDICAL DEVICES AND EQUIPMENT, CONSUMER HEALTH PRODUCTS, NATURAL HEALTH PRODUCTS, CLINICAL TRIAL AND SAP PRODUCTS, COSMETICS, BEAUTY SUPPLIES AND RELATED HEALTHCARE PRODUCTS (U.S. CLS. 100, 101 AND 102).

CLASS 39—TRANSPORTATION AND STORAGE

FOR WAREHOUSING SERVICES; AND REPACKAGING ARTICLES FOR TRANSPORTATION, ALL OF THE FOREGOING IN THE FIELDS OF HEALTHCARE, PHARMACEUTICALS, NARCOTICS AND CONTROLLED SUBSTANCES, BIOTECHNOLOGY, BIOPHARMACEUTICALS, NUTRITIONAL HEALTH PRODUCTS, DIAGNOSTIC, LABORATORY, MEDICAL DEVICES AND EQUIPMENT, CONSUMER HEALTH PRODUCTS, NATURAL HEALTH PRODUCTS, CLINICAL TRIAL AND SAP PRODUCTS, COSMETICS, BEAUTY SUPPLIES AND RELATED HEALTHCARE PRODUCTS (U.S. CLS. 100 AND 105).

CLASS 42—SCIENTIFIC AND COMPUTER SERVICES

FOR PROVIDING QUALITY ASSURANCE SERVICES IN THE FIELDS OF HEALTHCARE, PHARMACEUTICALS, NARCOTICS AND CONTROLLED SUBSTANCES, BIOTECHNOLOGY, BIOPHARMACEUTICALS, NUTRITIONAL HEALTH PRODUCTS, DIAGNOSTIC, LABORATORY, MEDICAL DEVICES AND EQUIPMENT, CONSUMER HEALTH PRODUCTS, NATURAL HEALTH PRODUCTS, CLINICAL TRIAL AND SAP PRODUCTS, COSMETICS, BEAUTY SUPPLIES AND RELATED HEALTHCARE PRODUCTS (U.S. CLS. 100 AND 101).
MARK T. MULLEN, EXAMINING ATTORNEY

SN 85-014,488. Y.S.PARK PROFESSIONAL INC., FORMERLY PARK WAY CO., LTD., SHINAGAWA-KU, TOKYO, JAPAN, FILED 4-15-2010.



OWNER OF JAPAN REG. NO. 5306923, DATED 3-5-2010, EXPIRES 3-5-2020.

OWNER OF U.S. REG. NO. 3,389,889.
NO CLAIM IS MADE TO THE EXCLUSIVE RIGHT TO USE "SUPER TOOL BEST PRO COLLECTION", APART FROM THE MARK AS SHOWN.

THE NAME(S), PORTRAIT(S), AND/OR SIGNATURE(S) SHOWN IN THE MARK IDENTIFIES "Y.S. PARK", WHOSE CONSENT(S) TO REGISTER IS MADE OF RECORD.

THE MARK CONSISTS OF THE MARK CONSISTS OF AN IMAGE OF A GLOBE INCLUDING LINES OF LATITUDE AND LINES OF LONGITUDE AND THE WORDING "Y.S.PARK SUPER TOOL BEST PRO COLLECTION" WITHIN THE BOUNDARIES OF THE GLOBE.

CLASS 8—HAND TOOLS

FOR HAIR CUTTING SCISSORS, RAZOR BLADES, STRAIGHT RAZORS (U.S. CLS. 23, 28 AND 44).

CLASS 11—ENVIRONMENTAL CONTROL APPARATUS

FOR HAIR DRYERS; CAPS FOR HAIR DRYERS, NAMELY, ION DIFFUSERS AND COVERS FOR THE HEADS OF HAIR DRYERS FOR HEAT PROTECTION (U.S. CLS. 13, 21, 23, 31 AND 34).

CLASS 21—HOUSEWARES AND GLASS

FOR COMBS, COMB CASES, HAIR BRUSHES (U.S. CLS. 2, 13, 23, 29, 30, 33, 40 AND 50).

CLASS 26—FANCY GOODS

FOR HAIR BANDS, HAIR PIN AND GRIPS (U.S. CLS. 37, 39, 40, 42 AND 50).
ZACHARY BELLO, EXAMINING ATTORNEY

SN 85-033,348. TRANS-HIGH CORPORATION, NEW YORK, NY. FILED 5-7-2010.

MEDICAL CANNABIS CUP

THE MARK CONSISTS OF STANDARD CHARACTERS WITHOUT CLAIM TO ANY PARTICULAR FONT, STYLE, SIZE, OR COLOR.

OWNER OF U.S. REG. NOS. 2,289,974 AND 2,581,279.
NO CLAIM IS MADE TO THE EXCLUSIVE RIGHT TO USE "MEDICAL CANNABIS" FOR THE GOODS IN CLASS 16 ONLY, APART FROM THE MARK AS SHOWN.

CLASS 16—PAPER GOODS AND PRINTED MATTER

FOR SERIES OF BOOKS ABOUT HEMP; POSTERS (U.S. CLS. 2, 5, 22, 23, 29, 37, 38 AND 50).

CLASS 25—CLOTHING

FOR T-SHIRTS, SWEATSHIRTS, CAPS (U.S. CLS. 22 AND 39).
LINDSEY RUBIN, EXAMINING ATTORNEY

SN 85-036,515. AQUAPAC INTERNATIONAL LIMITED, LONDON, UNITED KINGDOM, FILED 5-12-2010.

IMMERSE YOURSELF

THE MARK CONSISTS OF STANDARD CHARACTERS WITHOUT CLAIM TO ANY PARTICULAR FONT, STYLE, SIZE, OR COLOR.

OWNER OF ERPN CMNTY TM OFC REG. NO. 009094137, DATED 11-30-2010, EXPIRES 5-10-2020.

CLASS 9—ELECTRICAL AND SCIENTIFIC APPARATUS

FOR WATERPROOF TELEPHONES; WATERPROOF ENCLOSURES IN THE FORM OF CASES AND COVERS SPECIALLY DESIGNED FOR USE WITH RADIOS; WATERPROOF ELECTRONIC PERSONAL ORGANIZERS; WATERPROOF PERSONAL COMPUTERS; WATERPROOF COMPUTER DIGITAL MAPS, NAMELY, PRELOADED ELECTRONIC DEVICES FEATURING DIGITAL MAPS, AND GPS NAVIGATIONAL DEVICES; WATERPROOF AUDIO, VISUAL, VIDEO AND AUDIO-VIDEO MEDIA RECORDING AND PLAYBACK DEVICES, NAMELY, MP3 PLAYERS, COMPACT DISC PLAYERS, OPTICAL DISC PLAYERS, CASSETTE PLAYERS, CASSETTE RECORDERS, CAMERAS AND VIDEO RECORDERS; WATER AND SHOCK PROOF PROTECTIVE BAGS AND CARRYING CASES ALL SPECIALLY ADAPTED FOR USE WITH MOBILE PHONES AND OTHER ELECTRONIC GOODS USED IN OUTDOOR PURSUITS AND WATER SPORTS, NAMELY, RADIOS, CAMERAS, PERSONAL DIGITAL ASSISTANTS (PDA), MP3 PLAYERS, PORTABLE AND HANDHELD DIGITAL ELECTRONIC DEVICES FOR RECORDING, ORGANIZING, TRANSMITTING, MANIPULATING, AND REVIEWING AUDIO FILES, MOBILE PHONES, TELEPHONE AND PORTABLE ELECTRONIC COMMUNICATIONS DEVICES, CASSETTE RECORDERS, CASSETTE PLAYERS, CAMERAS, COMPACT DISC PLAYERS, VIDEO RECORDERS AND CAMCORDERS; SPECIALTY HOLSTERS FOR CARRYING CELLULAR PHONES, PAGERS, AND PERSONAL DIGITAL ASSISTANTS (U.S. CLS. 21, 23, 26, 36 AND 38).

CLASS 12—VEHICLES

FOR WATERPROOF CASES AND COVERS FOR THE ATTACHMENT OF PERSONAL ELECTRONIC DEVICES TO VEHICLES, NAMELY, BICYCLES, MOTORBIKES, CARS, VANS AND BOATS; WATERPROOF BAGS AND CASES SPECIALLY ADAPTED FOR ATTACHMENT OF PERSONAL ELECTRONIC DEVICES TO VEHICLES, NAMELY, BICYCLES, MOTORBIKES, CARS, VANS AND BOATS; RAIN-PROOF BAGS SPECIALLY ADAPTED FOR ATTACHMENT TO BICYCLES BY CYCLISTS AND BIKE PANNIER BAGS (U.S. CLS. 19, 21, 23, 31, 35 AND 44).

CLASS 16—PAPER GOODS AND PRINTED MATTER

FOR PLASTIC BAGS SPECIALLY ADAPTED FOR HOLDING MAPS AND DOCUMENTS; WATERPROOF DOCUMENT FOLDERS IN THE FORM OF WALLETS; WATERPROOF CHECKBOOK WALLETS; WATER AND RAIN-PROOF PLASTIC BAGS SPECIALLY ADAPTED FOR HOLDING WITH MAPS AND DOCUMENTS; RAIN-PROOF DOCUMENT FOLDERS IN THE FORM OF WALLETS; RAIN-PROOF CHECKBOOK WALLETS; MAPS; AND WATERPROOF PASSPORT HOLDERS IN THE NATURE OF WALLETS (U.S. CLS. 2, 5, 22, 23, 29, 37, 38 AND 50).

CLASS 18—LEATHER GOODS

FOR BAGS MADE OF VARIOUS MATERIALS, NAMELY, BAGS MADE OF LEATHER, IMITATION LEATHER, FABRIC, WATERPROOF FABRICS, CANVAS, PLASTIC, AND SEALABLE WATERPROOF MATERIAL INCLUDING HERMETICALLY SEALABLE BAGS, NAMELY, ALL-PURPOSE CARRYING BAGS, BEACH BAGS, BELT BAGS, CARRY-ALL BAGS, KEY BAGS, SPORTS BAGS, ATHLETIC BAGS, BABY BACKPACKS, BOOK BAGS, DUFFEL BAGS, GYM BAGS, COIN PURSES, KNAPSACKS, WAIST PACKS, GARMENT BAGS FOR TRAVEL, SHOE BAGS FOR TRAVEL, SCHOOL BAGS, SHOULDER BAGS, HANDBAGS, SATCHELS; SHOPPING BAGS OF CANVAS, LEATHER, MESH AND TEXTILE; TRAVELLING BAGS; UMBRELLAS; RUCKSACKS; BUM BAGS; WATERPROOF ALL PURPOSE SPORTS BAGS; TOTE BAGS; WATERPROOF ATTACHE CASES; WATERPROOF POCKET WALLETS; SPORT PACKS; SPECIALLY ADAPTED STRUCTURAL PARTS, FITTINGS AND FASTENINGS FOR ALL THE AFORESAID GOODS AND SOLD AS COMPONENT PARTS THEREWITH, NAMELY, HANDLES, STRAPS, BUCKLES, CLASPS AND ZIPPERS; PLASTIC WATER AND RAIN-PROOF BAGS SPECIALLY ADAPTED FOR HOLDING BOOKS; PLASTIC BAGS SPECIALLY ADAPTED FOR HOLDING BOOKS (U.S. CLS. 1, 2, 3, 22 AND 41).

FOR WATERPROOF FABRICS, NAMELY, POLYESTER, NYLON WEAVE AND COTTON FABRIC INCORPORATING A WATERPROOF PLASTIC MEMBRANE; WATERPROOF FABRICS FOR USE IN THE MANUFACTURE OF GLOVES; WATERPROOF FABRICS FOR USE IN THE MANUFACTURE OF HATS; WATERPROOF FABRICS FOR USE IN THE MANUFACTURE OF JACKETS; WATERPROOF FABRICS FOR USE IN THE MANUFACTURE OF TROUSERS; WATERPROOF TEXTILE FABRICS FOR MANUFACTURING PROTECTIVE BAGS, CARRYING CASES, CLOTHING, LUGGAGE; WOVEN FABRICS AND TEXTILE FABRICS, FOR THE MANUFACTURE OF CLOTHING, BAGS AND TENTS; SYNTHETIC FIBER FABRICS, NAMELY, PLASTIC SUBSTITUTES FOR USE AS FABRICS; TEXTILE TRAVELLING RUGS; WATERPROOF MATTRESS COVERS; MATTRESS COVERS (U.S. CLS. 42 AND 50).

CLASS 24—FABRICS

FOR RETAIL STORE SERVICES, ON-LINE RETAIL STORE SERVICES AVAILABLE THROUGH COMPUTER COMMUNICATIONS AND INTERACTIVE TELEVISION AND MAIL-ORDER SERVICES, ALL FEATURING WATERPROOF TELEPHONE AND COMMUNICATIONS APPARATUS, PERSONAL COMPUTERS, AUDIO, VISUAL, VIDEO AND AUDIO-VIDEO MEDIA RECORDING AND PLAYBACK DEVICES, BAGS MADE OF VARIOUS MATERIALS, BAGS, WATERPROOF BAGS, HERMETICALLY SEALABLE WATERPROOF BAGS, CASES, WALLETS, UMBRELLAS, RUCKSACKS, PANNIERS, APPARATUS FOR THE ATTACHMENT OF ELECTRONIC GOODS, BAGS AND CASES TO VEHICLES, FABRICS, TEXTILE TRAVELLING RUGS, WATERPROOF RUGS AND WATERPROOF MATTRESS COVERS; PROVIDING ON-LINE BUSINESS INFORMATION AND ADVICE RELATED TO RETAIL SALES SERVICES (U.S. CLS. 100, 101 AND 102).

CLASS 35—ADVERTISING AND BUSINESS

ALYSSA STEEL, EXAMINING ATTORNEY

SN 85-039,224. SOLFORCE SYSTEMS, INC., SANTA BARBARA, CA. FILED 5-14-2010.

SOLFORCE

THE MARK CONSISTS OF STANDARD CHARACTERS WITHOUT CLAIM TO ANY PARTICULAR FONT, STYLE, SIZE, OR COLOR.

CLASS 37—CONSTRUCTION AND REPAIR

FOR ELECTRICAL CONTRACTOR SERVICES; ELECTRICAL REPAIRS AND INSTALLATION OF ELECTRICAL SYSTEMS, SOLAR ENERGY BASED POWER PLANTS, RENEWABLE ENERGY SYSTEMS, PHOTOVOLTAIC INSTALLATIONS; INSTALLATION OF ELECTRICAL SYSTEMS, SOLAR ENERGY BASED POWER PLANTS, RENEWABLE ENERGY SYSTEMS, PHOTOVOLTAIC INSTALLATIONS; INSTALLATION OF ELECTRICAL AND GENERATING MACHINERY; INSTALLATION AND MAINTENANCE OF PHOTOVOLTAIC INSTALLATIONS; INSTALLATION AND MAINTENANCE OF SOLAR ENERGY BASED POWER PLANTS; INSTALLATION OF SOLAR ENERGY SYSTEMS AND ALTERNATIVE ENERGY PRODUCTS FOR RESIDENTIAL AND COMMERCIAL USE; REPAIR AND INSTALLATION SERVICES, NAMELY, THE INSTALLATION OF HEATING, COOLING AND ENVIRONMENTAL CONTROL SYSTEMS PRIMARILY USING SOLAR ENERGY, RENEWABLE ENERGY RESOURCES AND RAINWATER; CONSTRUCTION PROJECT MANAGEMENT SERVICES IN THE FIELD OF CONSTRUCTION OF RENEWABLE ENERGY AND ENERGY GENERATION EQUIPMENT SUPPORT STRUCTURES AND ANCILLARY STRUCTURES FOR SUPPORTING METEOROLOGICAL DATA GATHERING EQUIPMENT; HOME ENERGY ASSESSMENT SERVICES FOR THE PURPOSE OF DETERMINING HOME IMPROVEMENTS NEEDED TO IMPROVE ENERGY USE AND EFFICIENCY (U.S. CLS. 100, 103 AND 106).

FIRST USE 11-8-2007; IN COMMERCE 11-8-2007.

CLASS 40—MATERIAL TREATMENT

FOR TECHNICAL CONSULTATION IN THE FIELD OF PRODUCTION OF SOLAR ENERGY (U.S. CLS. 100, 103 AND 106).

FIRST USE 11-8-2007; IN COMMERCE 11-8-2007.

CLASS 42—SCIENTIFIC AND COMPUTER SERVICES

FOR CONSULTING SERVICES IN THE FIELDS OF ENERGY MEASUREMENT TO IMPROVE ENERGY EFFICIENCY; DESIGN OF SOLAR PHOTOVOLTAIC SYSTEMS; ELECTRONIC AND ELECTRICAL SYSTEMS DESIGN SERVICES; ENGINEERING SERVICES IN THE FIELD OF ENERGY EFFICIENCY; TECHNICAL PLANNING OF SOLAR ENERGY BASED POWER PLANTS; TECHNOLOGICAL CONSULTING SERVICES IN THE FIELD OF ALTERNATIVE ENERGY GENERATION; TECHNOLOGY PLANNING AND CONSULTING IN THE FIELD OF SOLAR ENERGY, SPECIFICALLY SPECIALIZING IN SUBSTRATES PRIMARILY OF CERAMIC, SILICON AND NON-METALS FOR ELECTRICAL OR THERMAL INSULATION OF SOLAR CELLS, PHOTOVOLTAIC CELLS, AND SOLAR COLLECTORS; AND SOLAR SYSTEMS (U.S. CLS. 100 AND 101).

FIRST USE 11-8-2007; IN COMMERCE 11-8-2007.

STEVEN JACKSON, EXAMINING ATTORNEY

SN 85-040,173. MOLECULAR DEVICES, LLC, SUNNYVALE, CA. FILED 5-17-2010.



The logo for Molecular Devices, featuring the word "Molecular" in a blue sans-serif font and "Devices" in a black sans-serif font.

OWNER OF U.S. REG. NOS. 1,607,261, 1,621,806 AND 3,458,076.

NO CLAIM IS MADE TO THE EXCLUSIVE RIGHT TO USE "DEVICES" IN INTERNATIONAL CLASS 9, AS TO "NON-MEDICAL RESEARCH, SCIENTIFIC AND PHARMACEUTICAL LABORATORY EQUIPMENT AND APPARATUS, NAMELY, FLUOROMETRIC IMAGING READERS,

MICROPLATE READERS, MICROARRAY ANALYSIS SCANNERS; ELECTROPHYSIOLOGY EQUIPMENT, NAMELY, MICROELECTRODE AMPLIFIERS; LABORATORY EQUIPMENT IN THE NATURE OF LIQUID HANDLING EQUIPMENT AND SUPERNATANT COLLECTION APPARATUS, NAMELY, CELL HARVESTERS, FRAMES, MACROWELL TUBES AND HOLDERS, HARVESTING PRESS, TRANSFER FORKS, CELL WASHERS, PLATE WASHERS, DISPENSERS", APART FROM THE MARK AS SHOWN.

THE COLOR(S) TEAL AND BLACK IS/ARE CLAIMED AS A FEATURE OF THE MARK.

THE MARK CONSISTS OF THE WORD "MOLECULAR" IN TEAL IN STYLIZED LETTERING, THE WORD "DEVICES" IN BLACK IN STYLIZED LETTERING.

SEC. 2(F) MOLECULAR DEVICES .

CLASS 1—CHEMICALS

FOR ASSAYS AND REAGENTS KITS COMPRISED OF ASSAYS, REAGENTS, PLATES, BUFFERS, ANTIBODIES, CALIBRATORS, CONJUGATES, WASH SOLUTION CONCENTRATE AND SUBSTRATE FOR USE IN SCIENTIFIC, PHARMACEUTICAL AND MEDICAL RESEARCH; QUANTITATIVE BIOLOGICAL ASSAYS AND GENETICALLY ENGINEERED BIOLOGICAL CELLS FOR BIOMEDICAL AND SCIENTIFIC RESEARCH (U.S. CLS. 1, 5, 6, 10, 26 AND 46).

CLASS 9—ELECTRICAL AND SCIENTIFIC APPARATUS

FOR NON-MEDICAL RESEARCH, SCIENTIFIC AND PHARMACEUTICAL LABORATORY EQUIPMENT AND APPARATUS, NAMELY, FLUOROMETRIC IMAGING READERS, MICROPLATE READERS, MICROARRAY ANALYSIS SCANNERS AND SOFTWARE FOR USE THEREWITH, NAMELY, OPERATING SOFTWARE, SOFTWARE FOR DATA WAREHOUSING, SOFTWARE FOR DATA ACQUISITION AND REPORTING, SOFTWARE FOR ADVANCED ANALYSIS AND VISUALIZATION, SOFTWARE FOR INSTRUMENT VALIDATION, AND OPERATING AND INSTRUCTION MANUALS RELATED TO ALL THE AFORESAID GOODS IN PRINTED FORMAT AND RECORDED ON COMPUTER MEDIA SOLD AS A UNIT THEREWITH; CALCULATION SOFTWARE FOR PERFORMING MATHEMATIC COMPUTATIONS, ANALYSIS, AND PRESENTATION OF DATA IN THE FIELD OF DRUG DISCOVERY AND LIFE SCIENCE RESEARCH, SOFTWARE TO CREATE AND APPLY MATHEMATICAL FORMULAS TO SPREADSHEETS IN THE FIELD OF DRUG DISCOVERY AND LIFE SCIENCE RESEARCH, AND OPERATING AND INSTRUCTION MANUALS RELATED TO ALL THE AFORESAID GOODS IN PRINTED FORMAT AND RECORDED ON COMPUTER MEDIA SOLD AS A UNIT THEREWITH; ELECTROPHYSIOLOGY EQUIPMENT, NAMELY, MICROELECTRODE AMPLIFIERS AND CELLULAR AND MOLECULAR DATA ACQUISITION SOFTWARE AND HARDWARE FOR DRUG DISCOVERY, AND OPERATING AND INSTRUCTION MANUALS RELATED TO ALL THE AFORESAID GOODS IN PRINTED FORMAT AND RECORDED ON COMPUTER MEDIA SOLD AS A UNIT THEREWITH; LABORATORY EQUIPMENT IN THE NATURE OF LIQUID HANDLING EQUIPMENT AND SUPERNATANT COLLECTION APPARATUS, NAMELY, CELL HARVESTERS, FRAMES, MACROWELL TUBES AND HOLDERS, HARVESTING PRESS, TRANSFER FORKS, CELL WASHERS, PLATE WASHERS, DISPENSERS AND RELATED OPERATING SOFTWARE, AND OPERATING AND INSTRUCTION MANUALS RELATED TO ALL THE AFORESAID GOODS IN PRINTED FORMAT AND RECORDED ON COMPUTER MEDIA SOLD AS A UNIT THEREWITH (U.S. CLS. 21, 23, 26, 36 AND 38).

CLASS 16—PAPER GOODS AND PRINTED MATTER

FOR PRINTED OPERATING AND INSTRUCTION MANUALS IN THE FIELD OF NON-MEDICAL RESEARCH, SCIENTIFIC AND PHARMACEUTICAL LABORATORY EQUIPMENT AND APPARATUS, NAMELY, FLUOROMETRIC IMAGING READERS, MICROPLATE READERS, MICROARRAY ANALYSIS SCANNERS AND SOFTWARE FOR USE THEREWITH, NAMELY, OPERATING SOFTWARE, SOFTWARE FOR DATA WAREHOUSING, SOFTWARE FOR DATA ACQUISITION AND REPORTING, SOFTWARE FOR ADVANCED ANALYSIS AND VISUALIZATION, SOFTWARE FOR INSTRUMENT VALIDATION, CALCULATION SOFTWARE FOR PERFORMING MATHEMATIC COMPUTATIONS, ANALYSIS AND PRESENTATION OF DATA IN THE FIELD OF DRUG DISCOVERY AND LIFE SCIENCE RESEARCH, AND SOFTWARE TO CREATE AND APPLY MATHEMATICAL FORMULAS TO SPREADSHEETS IN THE FIELD OF DRUG DISCOVERY AND LIFE SCIENCE RESEARCH, AND ELECTROPHYSIOLOGY EQUIPMENT, NAMELY, MICROELECTRODE AMPLIFIERS AND CELLULAR AND MOLECULAR DATA ACQUISITION SOFTWARE AND HARDWARE FOR DRUG DISCOVERY; PRINTED OPERATING AND INSTRUCTION MANUALS IN THE FIELD OF LABORATORY EQUIPMENT AND SUPERNATANT COLLECTION APPARATUS, NAMELY, CELL HARVESTERS, FRAMES, MACROWELL TUBES AND HOLDERS, HARVESTING PRESS, TRANSFER FORKS, CELL WASHERS, PLATE WASHERS, DISPENSERS AND RELATED OPERATING SOFTWARE (U.S. CLS. 2, 5, 22, 23, 29, 37, 38 AND 50).

TRACY FLETCHER, EXAMINING ATTORNEY

SN 85-040,479. MOLECULAR DEVICES, LLC, SUNNYVALE, CA. FILED 5-17-2010.



OWNER OF U.S. REG. NOS. 1,607,261, 3,458,076 AND OTHERS.

NO CLAIM IS MADE TO THE EXCLUSIVE RIGHT TO USE "DEVICES" IN INTERNATIONAL CLASS 9, AS TO "NON-MEDICAL RESEARCH, SCIENTIFIC AND PHARMACEUTICAL LABORATORY EQUIPMENT AND APPARATUS, NAMELY, FLUOROMETRIC IMAGING READERS, MICROPLATE READERS, MICROARRAY ANALYSIS SCANNERS; ELECTROPHYSIOLOGY EQUIPMENT, NAMELY, MICROELECTRODE AMPLIFIERS; LABORATORY EQUIPMENT IN THE NATURE OF LIQUID HANDLING EQUIPMENT AND SUPERNATANT COLLECTION APPARATUS, NAMELY, CELL HARVESTERS, FRAMES, MACROWELL TUBES AND HOLDERS, HARVESTING PRESS, TRANSFER FORKS, CELL WASHERS, PLATE WASHERS, DISPENSERS", APART FROM THE MARK AS SHOWN.

THE MARK CONSISTS OF THE WORDS "MOLECULAR DEVICES" IN STYLIZED LETTERING AND A CIRCLE AND SQUIGGLY LINE WITHIN A CIRCLE, AND ALL WITHIN A U SHAPED FIGURE.

SEC. 2(F) AS TO "MOLECULAR DEVICES".

CLASS 1—CHEMICALS

FOR ASSAYS AND REAGENTS KITS COMPRISED OF ASSAYS, REAGENTS, PLATES, BUFFERS, ANTIBODIES, CALIBRATORS, CONJUGATES, WASH SOLUTION CONCENTRATE AND SUBSTRATE FOR USE IN SCIENTIFIC, PHARMACEUTICAL AND MEDICAL RESEARCH; QUANTITATIVE BIOLOGICAL ASSAYS AND GENETICALLY ENGINEERED BIOLOGICAL CELLS FOR BIOMEDICAL AND SCIENTIFIC RESEARCH (U.S. CLS. 1, 5, 6, 10, 26 AND 46).

CLASS 9—ELECTRICAL AND SCIENTIFIC APPARATUS

FOR NON-MEDICAL RESEARCH, SCIENTIFIC AND PHARMACEUTICAL LABORATORY EQUIPMENT AND APPARATUS, NAMELY, FLUOROMETRIC IMAGING READERS, MICROPLATE READERS, MICROARRAY ANALYSIS SCANNERS AND SOFTWARE FOR USE THEREWITH, NAMELY, OPERATING SOFTWARE, SOFTWARE FOR DATA WAREHOUSING, SOFTWARE FOR DATA ACQUISITION AND REPORTING, SOFTWARE FOR ADVANCED ANALYSIS AND VISUALIZATION, SOFTWARE FOR INSTRUMENT VALIDATION, AND OPERATING AND INSTRUCTION MANUALS RELATED TO ALL THE AFORESAID GOODS IN PRINTED FORMAT AND RECORDED ON COMPUTER MEDIA SOLD AS A UNIT THEREWITH; CALCULATION SOFTWARE FOR PERFORMING MATHEMATIC COMPUTATIONS, ANALYSIS, AND PRESENTATION OF DATA IN THE FIELD OF DRUG DISCOVERY AND LIFE SCIENCE RESEARCH, SOFTWARE TO CREATE AND APPLY MATHEMATICAL FORMULAS TO SPREADSHEETS IN THE FIELD OF DRUG DISCOVERY AND LIFE SCIENCE RESEARCH, AND OPERATING AND INSTRUCTION MANUALS RELATED TO ALL THE AFORESAID GOODS IN PRINTED FORMAT AND RECORDED ON COMPUTER MEDIA SOLD AS A UNIT THEREWITH; ELECTROPHYSIOLOGY EQUIPMENT, NAMELY, MICROELECTRODE AMPLIFIERS AND CELLULAR AND MOLECULAR DATA ACQUISITION SOFTWARE AND HARDWARE FOR DRUG DISCOVERY, AND OPERATING AND INSTRUCTION MANUALS RELATED TO ALL THE AFORESAID GOODS IN PRINTED FORMAT AND RECORDED ON COMPUTER MEDIA SOLD AS A UNIT THEREWITH; LABORATORY EQUIPMENT IN THE NATURE OF LIQUID HANDLING EQUIPMENT AND SUPERNATANT COLLECTION APPARATUS, NAMELY, CELL HARVESTERS, FRAMES, MACROWELL TUBES AND HOLDERS, HARVESTING PRESS, TRANSFER FORKS, CELL WASHERS, PLATE WASHERS, DISPENSERS AND RELATED OPERATING SOFTWARE, AND OPERATING AND INSTRUCTION MANUALS RELATED TO ALL THE AFORESAID GOODS IN PRINTED FORMAT AND RECORDED ON COMPUTER MEDIA SOLD AS A UNIT THEREWITH (U.S. CLS. 21, 23, 26, 36 AND 38).

CLASS 16—PAPER GOODS AND PRINTED MATTER

FOR PRINTED OPERATING AND INSTRUCTION MANUALS IN THE FIELD OF NON-MEDICAL RESEARCH, SCIENTIFIC AND PHARMACEUTICAL LABORATORY EQUIPMENT AND APPARATUS, NAMELY, FLUOROMETRIC IMAGING READERS, MICROPLATE READERS, MICROARRAY ANALYSIS SCANNERS AND SOFTWARE FOR USE THEREWITH, NAMELY, OPERATING SOFTWARE, SOFTWARE FOR DATA WAREHOUSING, SOFTWARE FOR DATA ACQUISITION AND REPORTING, SOFTWARE FOR ADVANCED ANALYSIS AND VISUALIZATION, SOFTWARE FOR INSTRUMENT VALIDATION, CALCULATION SOFTWARE FOR PERFORMING MATHEMATIC COMPUTATIONS, ANALYSIS AND PRESENTATION OF DATA IN THE FIELD OF DRUG DISCOVERY AND LIFE SCIENCE RESEARCH, AND SOFTWARE TO CREATE AND APPLY MATHEMATICAL FORMULAS TO SPREADSHEETS IN THE FIELD OF DRUG DISCOVERY AND LIFE SCIENCE RESEARCH, AND ELECTROPHYSIOLOGY EQUIPMENT, NAMELY, MICROELECTRODE AMPLIFIERS AND CELLULAR AND MOLECULAR DATA ACQUISITION SOFTWARE AND HARDWARE FOR DRUG DISCOVERY; PRINTED OPERATING AND INSTRUCTION MANUALS IN THE FIELD OF LABORATORY EQUIPMENT AND SUPERNATANT COLLECTION APPARATUS, NAMELY, CELL HARVESTERS, FRAMES, MACROWELL TUBES AND HOLDERS, HARVESTING PRESS, TRANSFER FORKS, CELL WASHERS, PLATE WASHERS, DISPENSERS AND RELATED OPERATING SOFTWARE (U.S. CLS. 2, 5, 22, 23, 29, 37, 38 AND 50).

TRACY FLETCHER, EXAMINING ATTORNEY

SN 85-047,322. SAFARILAND, LLC, JACKSONVILLE, FL.
FILED 5-25-2010.

KLEENBORE

THE MARK CONSISTS OF STANDARD CHARACTERS WITHOUT CLAIM TO ANY PARTICULAR FONT, STYLE, SIZE, OR COLOR.

CLASS 3—COSMETICS AND CLEANING PREPARATIONS

FOR GUN-CLEANING PREPARATIONS (U.S. CLS. 1, 4, 6, 50, 51 AND 52).
FIRST USE 0-0-1977; IN COMMERCE 0-0-1977.

CLASS 11—ENVIRONMENTAL CONTROL APPARATUS

FOR BATTERY-OPERATED LIGHTS FOR GUN BORES (U.S. CLS. 13, 21, 23, 31 AND 34).
FIRST USE 1-0-1985; IN COMMERCE 1-0-1985.

CLASS 13—FIREARMS

FOR GUN-CLEANING BRUSHES; GUN-CLEANING CLOSER CAPS; GUN-CLEANING DECAPPERS; WIPING RODS FOR GUNS; KITS FOR CLEANING AND PRESERVING FIREARMS COMPOSED OF GUN CLEANING BRUSHES, CLOSER CUPS, CLEANING PREPARATIONS AND DECAPPERS (U.S. CLS. 2 AND 9).
FIRST USE 0-0-1977; IN COMMERCE 0-0-1977.

CLASS 21—HOUSEWARES AND GLASS

FOR GUN-CLEANING PATCHES AND RAGS (U.S. CLS. 2, 13, 23, 29, 30, 33, 40 AND 50).
FIRST USE 0-0-1977; IN COMMERCE 0-0-1977.
KYLE PEETE, EXAMINING ATTORNEY

SN 85-049,439. SAFARILAND, LLC, JACKSONVILLE, FL.
FILED 5-27-2010.



THE MARK CONSISTS OF THE WORD "KLEENBORE" ADJACENT TO THE STYLIZED IMAGE OF A GUN BARREL.

CLASS 3—COSMETICS AND CLEANING PREPARATIONS

FOR GUN-CLEANING PREPARATIONS (U.S. CLS. 1, 4, 6, 50, 51 AND 52).
FIRST USE 0-0-1977; IN COMMERCE 0-0-1977.

CLASS 11—ENVIRONMENTAL CONTROL APPARATUS

FOR BATTERY-OPERATED LIGHTS FOR GUN BORES (U.S. CLS. 13, 21, 23, 31 AND 34).
FIRST USE 1-0-1985; IN COMMERCE 1-0-1985.

CLASS 13—FIREARMS

FOR GUN-CLEANING BRUSHES; GUN-CLEANING CLOSER CAPS; GUN-CLEANING DECAPPERS; WIPING RODS FOR GUNS; KITS FOR CLEANING AND PRESERVING FIREARMS COMPOSED OF GUN CLEANING BRUSHES, CLOSER CUPS, CLEANING PREPARATIONS AND DECAPPERS (U.S. CLS. 2 AND 9).
FIRST USE 0-0-1977; IN COMMERCE 0-0-1977.

CLASS 21—HOUSEWARES AND GLASS

FOR GUN-CLEANING PATCHES AND RAGS (U.S. CLS. 2, 13, 23, 29, 30, 33, 40 AND 50).
FIRST USE 0-0-1977; IN COMMERCE 0-0-1977.
KYLE PEETE, EXAMINING ATTORNEY

SN 85-051,534. JYP ENTERTAINMENT CO., LTD., SEOUL, REPUBLIC OF KOREA, FILED 6-1-2010.

WONDER GIRLS

THE MARK CONSISTS OF STANDARD CHARACTERS WITHOUT CLAIM TO ANY PARTICULAR FONT, STYLE, SIZE, OR COLOR.

OWNER OF U.S. REG. NOS. 2,428,424, 3,804,795 AND 3,845,654.

CLASS 3—COSMETICS AND CLEANING PREPARATIONS

FOR EYEBROW PENCILS; EYEBROW COSMETICS; ROUGES; LIP LINER; LIPSTICKS; MASCARA; NAIL POLISH; PAINT AND VARNISH STRIPPING OR REMOVING PREPARATIONS; MAKE-UP FOUNDATIONS; COSMETICS AND MAKE-UP; HAIR COLORANTS; HAIR FIXERS; NON-MEDICATED BATH PREPARATIONS; BEAUTY CREAMS; BODY LOTIONS; BODY MILKS; BODY OILS; BODY CREAMS; BATH GELS; BATH LOTION; BATH BEADS; BATH OILS FOR COSMETIC PURPOSES; BATH FOAM; BABY OIL; BABY POWDER; CHEEK COLORS; BLUSHER; BLUSH PENCILS; SHOWER AND BATH GEL; SHOWER GELS; SHOWER CREAMS; SHOWER AND BATH FOAM; COSMETIC PREPARATIONS AGAINST SUNBURN; SUN-BLOCK LOTIONS; SUNSCREEN CREAMS; COSMETIC PREPARATIONS FOR EYE LASHES; SKIN LOTIONS; COSMETIC CREAMS FOR SKIN CARE; SKIN CREAMS; SKIN CLEANSERS; EYELINER; EYELINER PENCILS; EYE LOTIONS; EYE MAKE-UP REMOVERS; EYE SHADOWS; EYE CREAM; EYE PENCILS; AFTER SUN CREAMS; AFTER-SHAVE LOTIONS; AFTER-SHAVE EMULSIONS; AFTER-SHAVE CREAMS; TOILET WATER; LIP BRIGHTENERS; LIP NEUTRALIZERS; LIP CONDITIONERS; NON-MEDICATED LIP CARE PREPARATIONS; COSMETIC SUN-PROTECTING PREPARATIONS; COLD CREAMS; CLEANSING MILK; FOUNDATIONS; FOUNDATION CREAMS CREAMY FOUNDATION; FACE MILK AND LOTIONS; FACE AND BODY LOTIONS; FACE AND BODY MILK; LOTIONS FOR FACE AND BODY CARE; FACE AND BODY CREAMS; FACE POWDER PASTE; SKIN WHITENING CREAMS; HAND LOTIONS; HAIR LOTIONS; HAIR MOUSSE; HAIR STYLING SPRAY; HAIR SPRAY; HAIR CARE LOTIONS; OIL BATHS FOR HAIR CARE; HAIR CARE CREAMS; HAIR CREAMS; COSMETIC NOURISHING CREAMS; LOTIONS FOR COSMETIC PURPOSES; COSMETIC ROUGES; COSMETIC MASKS; NAIL VARNISH FOR COSMETIC PURPOSES; COSMETIC AFTER-SUN MILKS; LIQUID FOUNDATION; FACE POWDER; COSMETIC PENCILS; COSMETIC CLEANSING CREAMS; COSMETIC CREAMS; MAKE-UP POWDER; FACE CREAMS FOR COSMETIC USE; HAND CREAMS; MAKE-UP REMOVING LOTIONS; MAKE-UP REMOVING PREPARATIONS; SCENTED OILS USED TO PRODUCE AROMAS WHEN HEATED; FALSE EYELASHES;

ADHESIVES FOR AFFIXING FALSE EYELASHES; FALSE NAILS; TISSUES IMPREGNATED WITH COSMETIC LOTIONS; BEAUTY MASKS; COTTON STICKS FOR COSMETIC PURPOSES; SOAPS FOR HOUSEHOLD USE; SHAMPOOS; DISSOLVING PAPER SOAPS; CREAM SOAPS; HAND CLEANERS; PERFUMED SOAPS; HAIR RINSES; COSMETIC SOAPS (U.S. CLS. 1, 4, 6, 50, 51 AND 52).

CLASS 9—ELECTRICAL AND SCIENTIFIC APPARATUS

FOR CD PLAYERS; DVD PLAYERS; MP3 PLAYERS; RADIOTELEPHONY SETS; CELLULAR TELEPHONES; BLANK CD-ROMS FOR SOUND OR VIDEO RECORDING; AMUSEMENT APPARATUS ADAPTED FOR USE WITH TELEVISION RECEIVERS ONLY; VIRTUAL REALITY GAME SOFTWARE; COMPUTER PERIPHERAL DEVICES; PHONOGRAPH RECORDS FEATURING MUSIC; NEEDLES FOR RECORD PLAYERS; SPEED REGULATORS FOR RECORD PLAYERS, NAMELY, ELECTRONIC SPEED CONTROLLERS; TONE ARMS FOR RECORD PLAYERS; METRONOMES; HAND-OPERATED PHONOGRAPHS; MAGNETIC IDENTIFYING CARDS; PRE-PAID MAGNETICALLY ENCODED KEY CARDS; PRE-PAID MAGNETICALLY ENCODED RAILROAD TICKETS; MAGNETICALLY ENCODED TELEPHONE CALLING CARDS; MAGNETIC CARDS; MAGNETICALLY ENCODED CREDIT CARDS; EXPOSED X-RAY FILMS; EXPOSED SLIDE FILMS; EXPOSED CINEMATOGRAPHIC FILM; EXPOSED CAMERA FILMS; VIDEO DISKS AND VIDEO TAPES WITH RECORDED ANIMATED CARTOONS; EXPOSED SLIDE FILMS; DOWNLOADABLE VIRTUAL GOODS, NAMELY, COMPUTER PROGRAMS FEATURING ARTICLES OF CLOTHING AND JEWELRY FOR USE ON AVATARS AND IN ONLINE VIRTUAL WORLDS; DOWNLOADABLE VIRTUAL GOODS, NAMELY, COMPUTER PROGRAMS FEATURING AVATARS USED IN ONLINE VIRTUAL WORLDS; DOWNLOADABLE MP3 FILES, MP3 RECORDINGS, ON-LINE DISCUSSION BOARDS, WEBCASTS, WEBINARS AND PODCASTS FEATURING MUSIC, NEWS BROADCASTS, AND AUDIO BOOKS ABOUT MUSIC, MUSICAL EVENTS, PERFORMERS, FASHION, HEALTH, LEISURE, LIFESTYLE, AND CELEBRITIES (U.S. CLS. 21, 23, 26, 36 AND 38).

CLASS 16—PAPER GOODS AND PRINTED MATTER

FOR RUBBER ERASERS; NOTE BOOKS; FOUNTAIN PENS; MEMO PADS; STATIONERY; STICKERS; ADHESIVE TAPES FOR STATIONERY PURPOSES; GLUE FOR STATIONERY OR HOUSEHOLD USE; BALL PENS; FELT MARKING PENS; PHOTOGRAPHIC ALBUMS; PENCILS; SKETCHBOOKS; ELECTRIC PENCIL SHARPENERS; MECHANICAL PENCIL SHARPENERS; ADHESIVE NOTE PADS; ADHESIVE NOTE PAPER; CRAYONS; PASTEL CRAYONS; PENS; LETTER PAPER; WRITING INSTRUMENTS; WRITING CASES FOR HOLDING PENS AND PENCILS; PENCIL OR PEN BOXES; SCHOOL SUPPLY KITS CONTAINING VARIOUS COMBINATIONS OF SELECTED SCHOOL SUPPLIES, NAMELY, WRITING INSTRUMENTS, PENS, PENCILS, MECHANICAL PENCILS, ERASERS, MARKERS, CRAYONS, HIGHLIGHTER PENS, FOLDERS, NOTEBOOKS, PAPER, PROTRACTORS, PAPER CLIPS, PENCIL SHARPENERS, WRITING GRIPS, GLUE, AND BOOK MARKS; HIGHLIGHTER PENS; ADVERTISING PAMPHLETS AS GOODS IN TRADE; PICTURE POSTCARDS; CALENDARS; GREETING CARDS; POSTCARDS; DIARIES; POSTERS MADE OF PAPER; CATALOGUES IN THE FIELD OF MUSIC, MUSICAL EVENTS, PERFORMERS, FASHION, HEALTH, LEISURE, LIFESTYLE, AND CELEBRITIES; ENTRY TICKETS; PAMPHLETS IN THE FIELD OF MUSIC, MUSICAL EVENTS, PERFORMERS, FASHION, HEALTH, LEISURE, LIFESTYLE, AND CELEBRITIES; POSTERS; BROMIDE PRINTING PAPERS; PHOTOGRAPHS; PICTURE BOOKS; SONG BOOKS; CO-

MIC BOOKS; BOOKS IN THE FIELD OF MUSIC, MUSICAL EVENTS, PERFORMERS, FASHION, HEALTH, LEISURE, LIFESTYLE, AND CELEBRITIES; CARTOON STRIPS; MAGAZINES IN THE FIELD OF MUSIC, MUSICAL EVENTS, PERFORMERS, FASHION, HEALTH, LEISURE, LIFESTYLE, AND CELEBRITIES; PRINTED PERIODICALS IN THE NATURE OF MAGAZINES AND BOOKLETS IN THE FIELD OF MUSIC, MUSICAL EVENTS, PERFORMERS, FASHION, HEALTH, LEISURE, LIFESTYLE, AND CELEBRITIES; STUDY GUIDES (U.S. CLS. 2, 5, 22, 23, 29, 37, 38 AND 50).

CLASS 18—LEATHER GOODS

FOR TOILETRY BAGS SOLD EMPTY; COSMETIC BAGS SOLD EMPTY; COSMETIC CASES SOLD EMPTY; SHOPPING BAGS MADE OF SKIN; LEATHER HANDBAGS; SMALL BAGS FOR MEN; SMALL BAGS FOR WOMEN IN THE NATURE OF PURSES, SHOULDER BAGS, AND TOTE BAGS; BAGS FOR CLIMBERS IN THE NATURE OF AN ALL PURPOSE CARRYING BAG; RUCKSACKS FOR MOUNTAINEERS; BUSINESS CARD CASES; BOSTON BAGS; SMALL CLUTCH PURSES; VALISES; BAGS FOR SPORTS; TRAVELLING BAGS; PARASOLS; UMBRELLAS; LEATHER KEY CHAINS; LEATHER CASES FOR KEYS; IMITATION LEATHER KEY CHAINS (U.S. CLS. 1, 2, 3, 22 AND 41).

CLASS 28—TOYS AND SPORTING GOODS

FOR ARTIFICIAL CHRISTMAS TREES; BELLS FOR CHRISTMAS TREES; CHRISTMAS TREE ORNAMENTS; RUBBER CHARACTER TOYS; WAX DOLLS; MASCOT DOLLS; TOY BUILDING BLOCKS; DOLLS' CLOTHES; TEDDY BEARS; HAND-HELD GAMES WITH LIQUID CRYSTAL DISPLAYS; DARTS; ELECTRONIC GAMES OTHER THAN THOSE ADAPTED FOR USE WITH TELEVISION RECEIVERS ONLY; CHESSBOARDS; PUZZLES; BALLOONS; ROLLER SKATES; KNEE GUARDS FOR ATHLETIC USE; SNOW SHOES; BASEBALLS; IN-LINE SKATES; FOOTBALLS; BAGS FOR CLIMBERS SPECIALLY ADAPTED FOR HOLDING CLIMBING EQUIPMENT (U.S. CLS. 22, 23, 38 AND 50).

KATHRYN COWARD, EXAMINING ATTORNEY

SN 85-061,812. QUAD/GRAPHICS, INC., SUSSEX, WI. FILED 6-14-2010.

INNOVATIVE PEOPLE REDEFINING PRINT

THE MARK CONSISTS OF STANDARD CHARACTERS WITHOUT CLAIM TO ANY PARTICULAR FONT, STYLE, SIZE, OR COLOR.

CLASS 9—ELECTRICAL AND SCIENTIFIC APPARATUS

FOR COMPUTER SOFTWARE FOR PRINT PRODUCTION, GRAPHIC DESIGN, DIGITAL IMAGING, PREPRESS LAYOUT, COMMERCIAL PRINTING, DIGITAL AND DESKTOP PUBLISHING, AND WORKFLOW MANAGEMENT APPLICATIONS FOR THE PRINTING, PUBLISHING, ADVERTISING AND MARKETING INDUSTRIES (U.S. CLS. 21, 23, 26, 36 AND 38).

CLASS 35—ADVERTISING AND BUSINESS

FOR SORTING AND HANDLING OF MAIL; MAIL MONITORING AND TRACKING SERVICES; DIRECT MAIL CONSULTING SERVICES; BUSINESS SERVICES, NAMELY, ANALYSIS AND MANAGEMENT OF MAILING LISTS, CUSTOMER DATA AND MARKETING DATA; DEVELOPMENT OF MARKETING STRATEGIES AND CONCEPTS; ADVERTISING AND MARKETING SERVICES; BUSINESS MANAGEMENT SERVICES, NAMELY, PURCHASING OF PRINTING PAPER FOR OTHERS AND MANAGEMENT OF PRINTING PAPER INVENTORIES FOR OTHERS (U.S. CLS. 100, 101 AND 102).

CLASS 40—MATERIAL TREATMENT

FOR PRINTING SERVICES; PAPER DOCUMENT FINISHING SERVICES (U.S. CLS. 100, 103 AND 106).

CLASS 41—EDUCATION AND ENTERTAINMENT

FOR PHOTOGRAPHY SERVICES; DIGITAL IMAGING AND PRINT IMAGING SERVICES IN THE NATURE OF PHOTOGRAPHY, IMPOSITION, COLOR, PROOFING, LAYOUT DESIGN, PREPARATION OF PRINT PRODUCTION, PREPARATION OF CONTENT FOR PRINT PRODUCTION, PREPARATION OF FILES FOR PRINT PRODUCTION; DIGITAL PUBLISHING OF PRINTED AND DIGITAL PUBLICATIONS AND MATERIALS, NAMELY, MAGAZINES, CATALOGS, RETAIL INSERTS, DIRECTORIES, BOOKS, DIRECT MAIL PIECES, EMAIL ADVERTISEMENTS, ADVERTISEMENTS, INSERTS, ONSETS, SIGNAGE, PRINT ON DEMAND, BUSINESS COLLATERAL, NEWSPAPERS, WEBSITE CONTENT; DESKTOP PUBLISHING SERVICES (U.S. CLS. 100, 101 AND 107).

MICHAEL LITZAU, EXAMINING ATTORNEY

SN 85-065,042, FINNY'S GREENS, LLC, DBA TRAVELING DOG PRESS, TOPSAIL BEACH, NC. FILED 6-17-2010.

Jackson Goes

THE MARK CONSISTS OF STANDARD CHARACTERS WITHOUT CLAIM TO ANY PARTICULAR FONT, STYLE, SIZE, OR COLOR.

CLASS 16—PAPER GOODS AND PRINTED MATTER

FOR A SERIES OF EDUCATIONAL CHILDREN'S BOOKS AND PRINTED ITEMS BASED ON A TRAVELING DOG NAMED 'JACKSON', NAMELY, CHILDREN'S BOOKS, STATIONERY, PENCILS, PRINTED AWARD CERTIFICATES, EDUCATIONAL KITS SOLD IN THE FIELD AS A UNIT CONSISTING PRIMARILY OF EDUCATIONAL BOOKS AND FLASH CARDS, ART PRINTS ON CANVAS; GOODS BASED ON THE CHILDREN'S BOOK SERIES FEATURING A TRAVELING DOG NAMED 'JACKSON', NAMELY, CALENDARS, JOURNALS, STICKERS, CHILDREN'S ARTS AND CRAFTS PAPER KITS, NOTE CARDS, NOVELTY IDENTIFICATION DOCUMENTS IN THE NATURE OF IMITATION PASSPORTS, GIFT SETS CONSISTING OF BOOKS ABOUT A DOG NAMED 'JACKSON' AND A PLUSH DOLL (U.S. CLS. 2, 5, 22, 23, 29, 37, 38 AND 50). FIRST USE 2-23-2005; IN COMMERCE 2-23-2005.

CLASS 18—LEATHER GOODS

FOR GOODS BASED ON THE CHILDREN'S BOOK SERIES FEATURING A TRAVELING DOG NAMED 'JACKSON', NAMELY, LUGGAGE TAGS, ALL PURPOSE CARRYING BAGS (U.S. CLS. 1, 2, 3, 22 AND 41). FIRST USE 10-2-2010; IN COMMERCE 11-2-2010.

CLASS 28—TOYS AND SPORTING GOODS

FOR GOODS BASED ON THE CHILDREN'S BOOK SERIES FEATURING A TRAVELING DOG NAMED 'JACKSON', NAMELY, PLUSH DOLLS (U.S. CLS. 22, 23, 38 AND 50). FIRST USE 3-3-2010; IN COMMERCE 10-27-2010. ANNE MADDEN, EXAMINING ATTORNEY

SN 85-073,543. AGIGA TECH, INC., POWAY, CA. FILED 6-29-2010.

AgigaCAP

THE MARK CONSISTS OF STANDARD CHARACTERS WITHOUT CLAIM TO ANY PARTICULAR FONT, STYLE, SIZE, OR COLOR.

CLASS 9—ELECTRICAL AND SCIENTIFIC APPARATUS

FOR ENERGY PRODUCTS, NAMELY, SUPERCAPACITORS (U.S. CLS. 21, 23, 26, 36 AND 38).

CLASS 40—MATERIAL TREATMENT

FOR MANUFACTURING FOR OTHERS OF ENERGY PRODUCTS, NAMELY, SUPERCAPACITORS (U.S. CLS. 100, 103 AND 106). EVELYN BRADLEY, EXAMINING ATTORNEY

SN 85-073,936. CLAAS KGAA MBH, HARSEWINKEL, FED REP GERMANY, FILED 6-29-2010.



PRIORITY CLAIMED UNDER SEC. 44(D) ON FED REP GERMANY APPLICATION NO. 302010020994, FILED 6-14-2010, REG. NO. 009213836, DATED 12-6-2011, EXPIRES 6-14-2020.

THE MARK CONSISTS OF THE WORDING "ON TRACK" ABOVE WHICH APPEARS A SLANTED RECTANGLE TO THE RIGHT AND ABOVE APPEARS A REPRESENTATION OF A WRENCH ALL WITHIN A PARTIALLY SHADED SQUARE CONFIGURATION WITH A CURVED DESIGN. ABOVE THE WRENCH ARE THREE CURVED LINES DEPICTING A SOUND WAVE.

SN 85-073,955. CLAAS KGAA MBH, HARSEWINKEL, FED REP GERMANY, FILED 6-29-2010.

CLASS 7—MACHINERY

FOR AGRICULTURAL MACHINERY, NAMELY, COMBINE HARVESTERS, FORAGE HARVESTERS, BAILING PRESSES, MOWERS, AND SWATHERS; TENDERS AND PARTS AND COMPONENTS OF THE ABOVE (U.S. CLS. 13, 19, 21, 23, 31, 34 AND 35).

CLASS 9—ELECTRICAL AND SCIENTIFIC APPARATUS

FOR SCIENTIFIC-SURVEYING, ELECTRIC PHOTOGRAPHIC, OPTICAL WEIGHTING, MEASURING, SIGNALING, CONTROL APPARATUSES AND INSTRUMENTS, NAMELY, LASERS, SENSORS, SCALES AND CAMERAS; APPARATUS FOR RECORDING, TRANSMISSION AND REPRODUCTION OF SOUND AND IMAGES, NAMELY, SPEAKERS, RADIOS, RECEIVERS AND TRANSCEIVERS; CABLES, NAMELY, COAXIAL CABLES AND ELECTRICAL CABLES SWITCHES, NAMELY, ELECTRIC SWITCHES, AND ANTENNAS; MAGNETIC DATA CARRIERS, NAMELY, BLANK MAGNETIC DATA CARRIERS AND PRE-RECORDED MAGNETIC DATA CARRIERS FEATURING MAPS, AGRICULTURAL DATA AND AGRICULTURAL MACHINE INFORMATION; COMPUTING MACHINES AND PROCESSING DEVICES, NAMELY, COMPUTERS AND COMPUTER PROGRAMS FOR GLOBAL POSITIONING FOR USE IN HARVESTING, FOR USE IN MACHINE SERVING MANAGEMENT, LINKS, NAMELY, FUSIBLE LINKS, ELECTRICAL FUSES, AND TAPE MEASURES (U.S. CLS. 21, 23, 26, 36 AND 38).

CLASS 12—VEHICLES

FOR VEHICLES AND APPARATUS FOR TRANSPORT BY LAND, NAMELY, TRACTORS, TRAILERS FOR HAULING, HARVESTING PLANT MATERIAL, WAGONS, SELF-LOADING FORAGE WAGONS, SELF-LOADING FORAGE WAGONS FOR THE TRANSPORT OF HARVESTER PLAN MATERIALS; BRAKE LINES FOR VEHICLES, DRIVE GEARS, CLUTCHES FOR LAND VEHICLES, BRAKES FOR LAND VEHICLES (U.S. CLS. 19, 21, 23, 31, 35 AND 44).

CLASS 35—ADVERTISING AND BUSINESS

FOR RENDERING OF SERVICES IN THE AGRICULTURAL, GARDENING AND FORESTRY INDUSTRIES, NAMELY, CREATION OF MARKETING CONCEPTS FOR CONTRACTORS AND THE USE OF MACHINERY FOR MULTIPLE OPERATIONS; CREATION OF MARKETING CONCEPTS FOR COMPARING THE EFFICIENCY OF AGRICULTURAL MACHINERY; BUSINESS CONSULTATION RELATING TO METHODS AND SYSTEMS FOR PLANNING, ORGANIZING, LEADING AND CONTROLLING AGRICULTURAL OPERATIONS AND CONTRACTORS; BUSINESS CONSULTING RELATING TO THE OPTIMIZATION OF AGRICULTURAL MACHINE SYSTEMS AND TRANSPORT CHAINS FOR THE PURPOSE OF OPTIMIZING LOGISTICAL PROCESSES (U.S. CLS. 100, 101 AND 102).

CHERYL CLAYTON, EXAMINING ATTORNEY



PRIORITY CLAIMED UNDER SEC. 44(D) ON ERPNTY TM OFC APPLICATION NO. 009211657, FILED 6-14-2010, REG. NO. 009211657, DATED 12-13-2011, EXPIRES 6-14-2020.

THE MARK CONSISTS OF A SQUARE WITHIN WHICH THE WORD "EASY" APPEARS. AT THE TOP OF THE SQUARE THE WORDING "GO ON. GO EASY" APPEARS.

CLASS 7—MACHINERY

FOR AGRICULTURAL MACHINERY, NAMELY, COMBINE HARVESTERS, FORAGE HARVESTERS, BAILING PRESSES, MOWERS, AND SWATHERS; TENDERS AND PARTS AND COMPONENTS OF THE ABOVE (U.S. CLS. 13, 19, 21, 23, 31, 34 AND 35).

CLASS 9—ELECTRICAL AND SCIENTIFIC APPARATUS

FOR SCIENTIFIC-SURVEYING, ELECTRIC PHOTOGRAPHIC, OPTICAL WEIGHTING, MEASURING, SIGNALING, CONTROL APPARATUSES AND INSTRUMENTS, NAMELY, LASERS, SENSORS, SCALES AND CAMERAS; APPARATUS FOR RECORDING, TRANSMISSION AND REPRODUCTION OF SOUND AND IMAGES, NAMELY, SPEAKERS, RADIOS, RECEIVERS AND TRANSCEIVERS; CABLES, NAMELY, COAXIAL CABLES AND ELECTRICAL CABLES SWITCHES, NAMELY, ELECTRIC SWITCHES, AND ANTENNAS; MAGNETIC DATA CARRIERS, NAMELY, BLANK MAGNETIC DATA CARRIERS AND PRE-RECORDED MAGNETIC DATA CARRIERS FEATURING MAPS, AGRICULTURAL DATA AND AGRICULTURAL MACHINE INFORMATION; COMPUTING MACHINES AND PROCESSING DEVICES, NAMELY, COMPUTERS AND COMPUTER PROGRAMS FOR GLOBAL POSITIONING FOR USE IN HARVESTING, FOR USE IN MACHINE SERVING MANAGEMENT, LINKS, NAMELY, FUSIBLE LINKS, ELECTRICAL FUSES, AND TAPE MEASURES (U.S. CLS. 21, 23, 26, 36 AND 38).

CLASS 12—VEHICLES

FOR VEHICLES AND APPARATUS FOR TRANSPORT BY LAND, NAMELY, TRACTORS, TRAILERS FOR HAULING, HARVESTING PLANT MATERIAL, WAGONS, SELF-LOADING FORAGE WAGONS, SELF-LOADING FORAGE WAGONS FOR THE TRANSPORT OF HARVESTER PLAN MATERIALS; BRAKE LINES FOR VEHICLES, DRIVE GEARS, CLUTCHES FOR LAND VEHICLES, BRAKES FOR LAND VEHICLES (U.S. CLS. 19, 21, 23, 31, 35 AND 44).

CLASS 35—ADVERTISING AND BUSINESS

FOR RENDERING OF SERVICES IN THE AGRICULTURAL, GARDENING AND FORESTRY INDUSTRIES, NAMELY, CREATION OF MARKETING CONCEPTS FOR CONTRACTORS AND THE USE OF MACHINERY FOR MULTIPLE OPERATIONS; CREATION OF MARKETING CONCEPTS FOR COMPARING THE EFFICIENCY OF AGRICULTURAL MACHINERY; BUSINESS CONSULTATION RELATING TO METHODS AND SYSTEMS FOR PLANNING, ORGANIZING, LEADING AND CONTROLLING AGRICULTURAL OPERATIONS AND CONTRACTORS; BUSINESS CONSULTING RELATING TO THE OPTIMIZATION OF AGRICULTURAL MACHINE SYSTEMS AND TRANSPORT CHAINS FOR THE PURPOSE OF OPTIMIZING LOGISTICAL PROCESSES (U.S. CLS. 100, 101 AND 102).
CHERYL CLAYTON, EXAMINING ATTORNEY

SN 85-100,632. GENERAL DNA, INC., CARSON CITY, NV.
FILED 8-5-2010.

GENERAL DNA

THE MARK CONSISTS OF STANDARD CHARACTERS WITHOUT CLAIM TO ANY PARTICULAR FONT, STYLE, SIZE, OR COLOR.

NO CLAIM IS MADE TO THE EXCLUSIVE RIGHT TO USE "DNA", APART FROM THE MARK AS SHOWN.

CLASS 20—FURNITURE AND ARTICLES NOT OTHERWISE CLASSIFIED

FOR CONTAINERS FOR LONG-TERM STORAGE OF ORGANIC MATERIALS CONTAINING HUMAN DNA, NAMELY, NON-METAL AND PRIMARILY NON-METAL CONTAINERS FOR STORAGE OF HUMAN HAIR, NATURAL KERATIN FIBERS, TEETH AND BONE FOR MEDICAL AND SCIENTIFIC PURPOSES; NON-METAL AND PRIMARILY NON-METAL STORAGE DEVICES IN THE NATURE OF CONTAINERS FOR MEDICAL AND SCIENTIFIC USE, NAMELY, CAPSULES THAT PROTECT DNA MATERIAL FROM ENVIRONMENTAL INFLUENCES; NON-METAL AND PRIMARILY NON-METAL STORAGE DEVICES IN THE NATURE OF CONTAINERS FOR LONG-TERM CONSERVATION AND RECOVERY OF DNA FOR MEDICAL AND SCIENTIFIC PURPOSES; NON-METAL AND PRIMARILY NON-METAL STORAGE DEVICES FOR MEDICAL AND SCIENTIFIC USE, NAMELY, VESSELS THAT PROTECT DNA MATERIAL FROM ENVIRONMENTAL INFLUENCES; NON-METAL AND PRIMARILY NON-METAL STORAGE DEVICES FOR MEDICAL AND SCIENTIFIC USE, NAMELY, REPOSITORIES IN THE NATURE OF CONTAINERS FOR STORAGE AND PRESERVATION OF BIOLOGICAL MATERIALS (U.S. CLS. 2, 13, 22, 25, 32 AND 50).

CLASS 39—TRANSPORTATION AND STORAGE

FOR STORAGE, PROTECTION OF BIOLOGICAL MATERIALS, NAMELY, STORAGE OF HUMAN HAIR, NATURAL KERATIN FIBERS, TEETH AND BONE (U.S. CLS. 100 AND 105).

CLASS 44—MEDICAL, BEAUTY AND AGRICULTURAL SERVICES

FOR RECOVERY OF HUMAN DNA MATERIAL, NAMELY, COLLECTION OF HUMAN HAIR; PRESERVATION OF BIOLOGICAL MATERIALS, NAMELY, PRESERVATION OF HUMAN HAIR, NATURAL KERATIN FIBERS, TEETH AND BONE (U.S. CLS. 100 AND 101).

MICHELLE DUBOIS, EXAMINING ATTORNEY

SN 85-102,155. US AIRWAYS, INC., TEMPE, AZ. FILED 8-6-2010.

DIVIDEND MILES SHOPPING MALL

THE MARK CONSISTS OF STANDARD CHARACTERS WITHOUT CLAIM TO ANY PARTICULAR FONT, STYLE, SIZE, OR COLOR.

OWNER OF U.S. REG. NOS. 2,241,014, 2,269,473 AND 2,865,418.

NO CLAIM IS MADE TO THE EXCLUSIVE RIGHT TO USE "SHOPPING MALL", APART FROM THE MARK AS SHOWN.

CLASS 35—ADVERTISING AND BUSINESS

FOR ONLINE RETAIL STORE AND SHOPPING MALL SERVICES FEATURING A WIDE VARIETY OF CONSUMER GOODS AND SERVICES OF OTHERS OFFERED THROUGH A FREQUENT FLIER PROGRAM IN WHICH POINTS ARE ACCUMULATED TO EARN FREQUENT FLIER MILES BASED ON PURCHASES OF SUCH GOODS AND SERVICES (U.S. CLS. 100, 101 AND 102).
FIRST USE 10-16-2006; IN COMMERCE 10-16-2006.

CLASS 39—TRANSPORTATION AND STORAGE

FOR AIR TRANSPORTATION SERVICES FEATURING A SPECIALIZED FREQUENT FLIER PROGRAM (U.S. CLS. 100 AND 105).

FIRST USE 10-16-2006; IN COMMERCE 10-16-2006.
ALLISON HOLTZ, EXAMINING ATTORNEY

SN 85-105,721. LANGUES VIVANTES - INTERLINGUA, BRUSSELS, BELGIUM, FILED 8-12-2010.

EASY LANGUAGES

THE MARK CONSISTS OF STANDARD CHARACTERS WITHOUT CLAIM TO ANY PARTICULAR FONT, STYLE, SIZE, OR COLOR.

NO CLAIM IS MADE TO THE EXCLUSIVE RIGHT TO USE "LANGUAGES", APART FROM THE MARK AS SHOWN.

CLASS 39—TRANSPORTATION AND STORAGE

FOR PROVIDING TRAVEL PROGRAMS WORLDWIDE, NAMELY, ARRANGING TRAVEL TOURS EMPHASIZING CULTURAL IMMERSION AND USE OF LANGUAGE; AND TRANSPORTATION SERVICES, NAMELY, ARRANGEMENT OF TRAVEL ITINERARIES VIA TRAIN, BUS OR AIR, NAMELY, MAKING TICKET RESERVATIONS FOR OTHERS (U.S. CLS. 100 AND 105).
FIRST USE 7-3-2005; IN COMMERCE 7-3-2005.

CLASS 41—EDUCATION AND ENTERTAINMENT

FOR EDUCATIONAL SERVICES, NAMELY, PROVIDING COURSES OF INSTRUCTION INCLUDING THE DISTRIBUTION OF COURSE MATERIAL IN CONNECTION THEREWITH, CULTURAL IMMERSION, HOST-FAMILY OR RESIDENTIAL ACCOMMODATION, AND TRAVEL PROGRAMS WORLDWIDE; AND CONDUCTING GUIDED TOURS EMPHASIZING CULTURAL IMMERSION AND USE OF LANGUAGE, NAMELY, VISITS TO MONUMENTS, CULTURALLY SIGNIFICANT LOCATIONS, MUSEUMS, THEATRICAL PERFORMANCES, AND CULTURAL EVENTS SUCH AS FESTIVALS, COOKING LESSONS, WINE TASTINGS AND FOOD TASTINGS (U.S. CLS. 100, 101 AND 107).
FIRST USE 7-3-2005; IN COMMERCE 7-3-2005.
EUGENIA MARTIN, EXAMINING ATTORNEY

SN 85-111,023. TAIYO KOGYO CORPORATION, OSAKA, JAPAN, FILED 8-19-2010.



OWNER OF U.S. REG. NOS. 3,108,481 AND 3,390,517.
THE MARK CONSISTS OF THE WORD "BIRDAIR" WITHIN A RECTANGULAR DESIGN HAVING FIVE HORIZONTAL LINE FRAGMENTS.

CLASS 35—ADVERTISING AND BUSINESS

FOR DISTRIBUTORSHIP SERVICES IN THE FIELD OF FABRICATED FABRIC MEMBRANES (U.S. CLS. 100, 101 AND 102).
FIRST USE 11-29-2007; IN COMMERCE 11-29-2007.

CLASS 37—CONSTRUCTION AND REPAIR

FOR INSTALLATION AND MAINTENANCE OF BOTH STANDARD AND CUSTOM-MADE AIR-SUPPORTED, CABLE SUPPORTED OR RIGID FRAME-SUPPORTED ROOFS OR ROOF SECTIONS, SKYLIGHTS, AWNINGS AND COMMERCIAL UMBRELLAS, CONTAINING FABRIC-LIKE OR MEMBRANE-LIKE FLEXIBLE MATERIALS, INCLUDING METAL MATERIALS, AS AN INTEGRAL PART OF THE STRUCTURE; ROOF SERVICE CONTRACT SERVICE, NAMELY, REPLACEMENT OF DEFECTIVE OR DAMAGED ROOFS, CONSTRUCTION OF RIGID FRAME-SUPPORTED ROOFS OR ROOF SECTIONS AS PART OF A STRUCTURE; CONSTRUCTION PROJECT MANAGEMENT FOR OTHERS OF BOTH STANDARD AND CUSTOM-MADE AIR-SUPPORTED, CABLE SUPPORTED OR RIGID FRAME SUPPORTED ROOFS OR ROOF SECTIONS, SKYLIGHTS, AWNINGS AND COMMERCIAL UMBRELLAS, CONTAINING FABRIC-LIKE OR MEMBRANE-LIKE FLEXIBLE MATERIALS, INCLUDING METAL MATERIALS, AS AN INTEGRAL PART OF THE STRUCTURE (U.S. CLS. 100, 103 AND 106).
FIRST USE 11-29-2007; IN COMMERCE 11-29-2007.

CLASS 40—MATERIAL TREATMENT

FOR CUSTOM CONSTRUCTION OF BOTH STANDARD AND CUSTOM-MADE AIR-SUPPORTED, CABLE SUPPORTED SKYLIGHTS, AWNINGS AND COMMERCIAL UMBRELLAS, CONTAINING FABRIC-LIKE OR MEMBRANE-LIKE FLEXIBLE MATERIALS, INCLUDING METAL MATERIALS, AS AN INTEGRAL PART OF THE STRUCTURE (U.S. CLS. 100, 103 AND 106).
FIRST USE 11-29-2007; IN COMMERCE 11-29-2007.

CLASS 42—SCIENTIFIC AND COMPUTER SERVICES

FOR DESIGN, ENGINEERING, INSPECTION OF BOTH STANDARD AND CUSTOM-MADE AIR-SUPPORTED, CABLE SUPPORTED SKYLIGHTS, AWNINGS AND COMMERCIAL UMBRELLAS, CONTAINING FABRIC-LIKE OR MEMBRANE-LIKE FLEXIBLE MATERIALS, INCLUDING METAL MATERIALS, AS AN INTEGRAL PART OF THE STRUCTURE (U.S. CLS. 100 AND 101).
FIRST USE 11-29-2007; IN COMMERCE 11-29-2007.
NAPOLEON SHARMA, EXAMINING ATTORNEY

SN 85-112,455. GEKA GMBH, BECHHOFEN, FED REP GERMANY, FILED 8-20-2010.

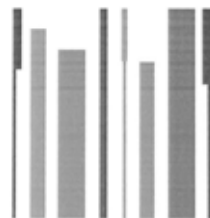

PRIORITY CLAIMED UNDER SEC. 44(D) ON ERPNCMNTY TM OFC APPLICATION NO. 008900524, FILED 2-22-2010, REG. NO. 008900524, DATED 9-14-2010, EXPIRES 2-22-2020.

THE MARK CONSISTS OF 8 SPACED-APART VERTICAL BANDS OF VARIOUS WIDTHS.

CLASS 3—COSMETICS AND CLEANING PREPARATIONS

FOR COSMETIC PADS FOR APPLYING COSMETICS; COMPLETE COSMETIC APPLICATION SYSTEMS IN THE NATURE OF PLASTIC COSMETIC CONTAINERS SOLD FILLED WITH COSMETIC FLUID OR COSMETICS (U.S. CLS. 1, 4, 6, 50, 51 AND 52).

CLASS 20—FURNITURE AND ARTICLES NOT OTHERWISE CLASSIFIED

FOR PLASTIC CONTAINERS FOR COSMETICS SOLD EMPTY AND PLASTIC CLOSURES THEREFOR; PLASTIC CONTAINER CLOSURES IN THE FORM OF SCREW-ON, SNAP-ON AND PUSH-ON CLOSURES FOR COSMETIC, TECHNICAL, PHARMACEUTICAL AND MEDICAL APPLICATIONS; COMPLETE COSMETICS APPLICATION SYSTEMS IN THE NATURE OF PLASTIC COSMETICS CONTAINERS SOLD EMPTY FOR COMMERCIAL PACKAGING, CONSISTING PRIMARILY OF AT LEAST ONE CONTAINER, AT LEAST ONE COSMETICS APPLICATOR, AND AT LEAST ONE MAKE-UP DOSING DEVICE IN THE NATURE OF A WIPER FOR THE DOSED DISPENSING OF COSMETIC LIQUIDS FROM THE CONTAINER TO THE APPLICATOR (U.S. CLS. 2, 13, 22, 25, 32 AND 50).

CLASS 21—HOUSEWARES AND GLASS

FOR BRUSHES, EXCLUDING PAINT BRUSHES, MADE OF PLASTIC OR FOAM FOR APPLYING, CLEANING AND REMOVING PURPOSES, FOR COSMETIC AND DENTAL APPLICATIONS; EYEBROW BRUSHES, EYELASH BRUSHES, MASCARA BRUSHES, HAIR FOR BRUSHES, ANIMAL BRISTLES FOR BRUSHES AND BRUSH GOODS, ELECTRIC BRUSHES THAT ARE NOT MACHINE PARTS, NAMELY, ELECTRIC COSMETIC BRUSHES, ELECTRIC LIP GLOSS BRUSHES, ELECTRIC TOOTHBRUSHES, AND ELECTRIC MASCARA BRUSHES; BRUSHES COMPRISING A WIRE CORE, NOT BEING MACHINE PARTS; NAIL BRUSHES, COSMETIC COMPACT CASES SOLD EMPTY, BRUSHES FOR APPLYING COSMETICS, NAMELY, APPLICATORS, COSMETIC ACCESSORIES, NAMELY, COSMETIC BRUSHES, HAIR BRUSHES, AND HAIR COMBS; AIDS FOR APPLYING COSMETICS, NAMELY, SPONGES, BRUSHES, SPATULAS, AND FACIAL BUFFING PADS; COSMETIC IMPLEMENTS FOR APPLYING HAIR DYES; PLASTIC CONTAINERS FOR COSMETICS FOR PERSONAL USE (U.S. CLS. 2, 13, 23, 29, 30, 33, 40 AND 50).

YAT SYE, LEE, EXAMINING ATTORNEY

SN 85-116,641. CVS PHARMACY, INC, WOONSOCKET, RI.
FILED 8-26-2010.

TOTAL HOME

THE MARK CONSISTS OF STANDARD CHARACTERS WITHOUT CLAIM TO ANY PARTICULAR FONT, STYLE, SIZE, OR COLOR.

NO CLAIM IS MADE TO THE EXCLUSIVE RIGHT TO USE "HOME", APART FROM THE MARK AS SHOWN.

CLASS 1—CHEMICALS

FOR POTTING SOIL (U.S. CLS. 1, 5, 6, 10, 26 AND 46).

CLASS 3—COSMETICS AND CLEANING PREPARATIONS

FOR WASHING PREPARATIONS AND LAUNDRY BLEACHES; DRAIN OPENERS; DISPOSABLE WIPES IMPREGNATED WITH CLEANING CHEMICALS OR COMPOUNDS FOR HOUSEHOLD USE; OVEN CLEANER; ALL-PURPOSE CLEANERS; CARPET CLEANERS; STAIN REMOVERS; LAUNDRY DETERGENTS; FABRIC SOFTENERS; SPRAY CLEANERS FOR INDUSTRIAL AND HOUSEHOLD APPLICATIONS SUCH AS STAIN REMOVAL AND ODOR ELIMINATION (U.S. CLS. 1, 4, 6, 50, 51 AND 52).

CLASS 4—LUBRICANTS AND FUELS

FOR CANDLES (U.S. CLS. 1, 6 AND 15).

CLASS 5—PHARMACEUTICALS

FOR ANTI-ANT AND ROACH SPRAYS AND BAITS; INSECT REPELLENTS; DISINFECTANT TOILET BOWL CLEANERS; DISINFECTANT BATHROOM CLEANERS; AIR FRESHENERS (U.S. CLS. 6, 18, 44, 46, 51 AND 52).

CLASS 6—METAL GOODS

FOR ALUMINUM FOIL (U.S. CLS. 2, 12, 13, 14, 23, 25 AND 50).

CLASS 7—MACHINERY

FOR ELECTRIC MIXERS FOR HOUSEHOLD PURPOSES AND ELECTRIC CAN OPENERS (U.S. CLS. 13, 19, 21, 23, 31, 34 AND 35).

CLASS 8—HAND TOOLS

FOR GARDENING SUPPLIES, NAMELY, GARDENING SHEARS AND SCISSORS, TROWELS, WEEDING FORKS, AND SPADES (U.S. CLS. 23, 28 AND 44).

CLASS 9—ELECTRICAL AND SCIENTIFIC APPARATUS

FOR BATTERIES (U.S. CLS. 21, 23, 26, 36 AND 38).

CLASS 11—ENVIRONMENTAL CONTROL APPARATUS

FOR LIGHT BULBS; FLASHLIGHTS; SMALL KITCHEN APPLIANCES, NAMELY, ELECTRIC COFFEE MAKERS, ELECTRIC TOASTERS, ELECTRIC RICE COOKERS, AND ELECTRIC WAFFLE IRONS (U.S. CLS. 13, 21, 23, 31 AND 34).

CLASS 16—PAPER GOODS AND PRINTED MATTER

FOR HOUSEHOLD PAPER PRODUCTS, NAMELY, TOILET PAPER, PAPER TOWELS AND PAPER NAPKINS; FACIAL TISSUE; SANDWICH BAGS; PLASTIC WRAP; PLASTIC TRASH BAGS; PHOTOGRAPH ALBUMS (U.S. CLS. 2, 5, 22, 23, 29, 37, 38 AND 50).

CLASS 18—LEATHER GOODS

FOR REUSABLE SHOPPING BAGS (U.S. CLS. 1, 2, 3, 22 AND 41).

CLASS 20—FURNITURE AND ARTICLES NOT OTHERWISE CLASSIFIED

FOR COAT HANGERS; FURNITURE; PICTURE FRAMES (U.S. CLS. 2, 13, 22, 25, 32 AND 50).

CLASS 21—HOUSEWARES AND GLASS

FOR RUBBER HOUSEHOLD GLOVES; MOPS AND BROOMS; DUSTERS; CLEANING SPONGES; DISPOSABLE LATEX GLOVES FOR GENERAL USE; DISPOSABLE DINNERWARE, NAMELY, PLASTIC AND PAPER CUPS AND PLATES; HOUSEHOLD CONTAINERS FOR FOOD (U.S. CLS. 2, 13, 23, 29, 30, 33, 40 AND 50).

CLASS 24—FABRICS

FOR KITCHEN TOWELS; BLANKET THROWS (U.S. CLS. 42 AND 50).

DEIRDRE ROBERTSON, EXAMINING ATTORNEY

SN 85-117,736. DGP AMERICAS, LLC, INDIANAPOLIS, IN.
FILED 8-27-2010.

INTELSIUS

THE MARK CONSISTS OF STANDARD CHARACTERS WITHOUT CLAIM TO ANY PARTICULAR FONT, STYLE, SIZE, OR COLOR.

CLASS 1—CHEMICALS

FOR KITS FOR THE COLLECTION AND TRANSPORTATION OF GENETIC SAMPLES COMPRISED PRIMARILY OF REAGENTS FOR CHEMICAL ANALYSIS, RESEARCH PURPOSES, AND SCIENTIFIC OR MEDICAL RESEARCH USE, AND ALSO CONTAINING PRESERVING SOLUTION, TRANSPORT PACKAGING, COLLECTION CONTAINERS, AND INSTRUCTIONS (U.S. CLS. 1, 5, 6, 10, 26 AND 46).

CLASS 16—PAPER GOODS AND PRINTED MATTER

FOR PACKAGING AND CONTAINERS FOR SHIPPING HEALTH, MEDICAL, BIOLOGICAL, AND BIOPHARMACEUTICAL SAMPLES MADE PRIMARILY OF CARDBOARD, BUT ALSO CONTAINING EXPANDED POLYSTYRENE; INSULATED PACKAGING AND SHIPPING CONTAINERS MADE PRIMARILY OF CARDBOARD, BUT ALSO CONTAINING EXPANDED POLYSTYRENE, FOR CRYOPRESERVING HEALTH, MEDICAL, BIOLOGICAL, AND BIOPHARMACEUTICAL SAMPLES; KITS COMPRISED OF TRANSPORT PACKAGING AND SHIPPING CONTAINERS CONSISTING PRIMARILY OF CARDBOARD, BUT ALSO CONTAINING EXPANDED POLYSTYRENE, AND ALSO CONTAINING PRESERVING SOLUTION, COLLECTION CONTAINERS, AND INSTRUCTIONS (U.S. CLS. 2, 5, 22, 23, 29, 37, 38 AND 50).

MARCIE MILONE, EXAMINING ATTORNEY

SN 85-119,818. ACCESS COMMUNICATIONS, LLC, BERKELEY HEIGHTS, NJ. FILED 8-31-2010.



The Access Group

NO CLAIM IS MADE TO THE EXCLUSIVE RIGHT TO USE "GROUP", APART FROM THE MARK AS SHOWN.

THE MARK CONSISTS OF A SQUARE CONTAINING STYLIZED CAPITAL LETTERS "A" AND "G", WITH THE WORDS "THE ACCESS GROUP" APPEARING BELOW THE SQUARE.

CLASS 35—ADVERTISING AND BUSINESS

FOR BUSINESS MANAGEMENT CONSULTING SERVICES, INCLUDING MANAGED MARKETS AND ALL PAYER CHANNEL CONSULTING SERVICES; STRATEGIC AND MANAGEMENT BUSINESS CONSULTING IN THE PHARMACEUTICAL, BIOTECHNOLOGY AND HEALTHCARE FIELDS (U.S. CLS. 100, 101 AND 102).

CLASS 38—COMMUNICATION

FOR COMMUNICATIONS SERVICES, NAMELY, TRANSMISSION OF VOICE, AUDIO, VISUAL IMAGES AND DATA BY TELECOMMUNICATIONS NETWORKS, WIRELESS COMMUNICATION NETWORKS, THE INTERNET, INFORMATION SERVICES NETWORKS AND DATA NETWORKS IN THE FIELD OF MANAGED HEALTHCARE MARKETS (U.S. CLS. 100, 101 AND 104).

CLASS 41—EDUCATION AND ENTERTAINMENT

FOR MEDICAL EDUCATION SERVICES, NAMELY, DEVELOPING AND DISSEMINATING TRAINING AND EDUCATIONAL MATERIALS, INCLUDING ACCREDITED MEDICAL EDUCATION CONTENT AND SERVICES, FOR USE BY CLIENTS IN THE PHARMACEUTICAL AND MEDICAL FIELDS FOR THE MARKETING AND SALES OF NEW DRUGS AND MEDICAL AND PHARMACEUTICAL ADVANCEMENTS; EDUCATIONAL SERVICES, NAMELY, PROVIDING STRATEGIC TRAINING PROGRAMS IN THE FIELDS OF MANAGED MARKETS AND MANAGED HEALTHCARE, INCLUDING ALL GOVERNMENT PAYER CHANNELS ADDRESSING REIMBURSEMENTS, MANAGED CARE, HEALTH CARE REFORM, EMPLOYER BENEFITS, SECONDARY INSURANCE, COMPARATIVE EFFECTIVENESS AND LONG TERM CARE (U.S. CLS. 100, 101 AND 107).

NICHOLAS ALTREE, EXAMINING ATTORNEY

SN 85-120,692. DAVE EDWARDS ENTERTAINMENT MEDIA LTD., CARMARTHENSHIRE, UNITED KINGDOM, FILED 9-1-2010.

ARTY and friends

THE MARK CONSISTS OF STANDARD CHARACTERS WITHOUT CLAIM TO ANY PARTICULAR FONT, STYLE, SIZE, OR COLOR.

PRIORITY CLAIMED UNDER SEC. 44(D) ON ERPNTY TM OFC APPLICATION NO. 008923881, FILED 3-3-2010, REG. NO. 008923881, DATED 8-24-2010, EXPIRES 3-3-2020.

CLASS 9—ELECTRICAL AND SCIENTIFIC APPARATUS

FOR TELEPHONES; COMPUTER GAMES PROGRAMS; ELECTRONIC GAME PROGRAMS; VIDEO GAME SOFTWARE; AMUSEMENT APPARATUS AND GAMES ADAPTED FOR USE WITH TELEVISION RECEIVERS OR WITH VIDEO OR COMPUTER MONITORS; AMUSEMENT MACHINES, NAMELY, HAND-HELD ELECTRONIC GAME UNITS ADAPTED FOR USE WITH AN EXTERNAL DISPLAY SCREEN OR MONITOR; CONSOLE GAMES APPARATUS, NAMELY, COMPUTER GAME CONSOLES FOR USE WITH AN EXTERNAL DISPLAY SCREEN OR MONITOR; DATA CARRIERS AND SOFTWARE FOR COMPUTER GAMES OR ELECTRONIC GAMES, NAMELY, CARDS OR DISKS, NAMELY, FLASH MEMORY CARDS; COMPUTER SOFTWARE FOR EDUCATIONAL GAMES FOR CHILDREN (U.S. CLS. 21, 23, 26, 36 AND 38).

CLASS 16—PAPER GOODS AND PRINTED MATTER

FOR PRINTED MATTER, NAMELY, GREETING CARDS, POSTERS, WRAPPING PAPER, DECALS, STICKERS AND TRADING CARDS; BOOKS AND MAGAZINES IN THE FIELD OF CHILDREN'S EDUCATION; PHOTOGRAPHS; STATIONERY; ADHESIVES FOR STATIONERY OR HOUSEHOLD PURPOSES; ARTISTS' MATERIALS, NAMELY, BRUSHES, PENCILS, GLUE FOR STATIONERY PURPOSES, STENCILS, MOLDING CLAY AND MODELING MATERIALS (U.S. CLS. 2, 5, 22, 23, 29, 37, 38 AND 50).

CLASS 28—TOYS AND SPORTING GOODS

FOR GAMES, NAMELY, BOARD GAMES, CARD GAMES, DRAWING GAMES, AND ELECTRONIC HANDHELD GAMES, NAMELY, HAND HELD UNITS FOR PLAYING ELECTRONIC GAMES OTHER THAN THOSE ADAPTED FOR USE WITH AN EXTERNAL DISPLAY SCREEN OR MONITOR; TOYS, NAMELY, PLUSH TOYS; BATHTUB TOYS; AND PLAYTHINGS, NAMELY, JIGSAWS AND MANIPULATIVE PUZZLES (U.S. CLS. 22, 23, 38 AND 50).

CLASS 41—EDUCATION AND ENTERTAINMENT

FOR ENTERTAINMENT SERVICES IN THE NATURE OF ON-GOING TELEVISION PROGRAMS IN THE FIELD OF CHILDREN'S ENTERTAINMENT FEATURING ANIMATED CARTOONS; FILM PRODUCTION FOR ENTERTAINMENT PURPOSES; PRODUCTION OF ENTERTAINMENT IN THE FORM OF A TELEVISION PROGRAM OR SERIES FEATURING CHILDREN'S EDUCATIONAL MATERIAL; PRODUCTION OF ENTERTAINMENT IN THE FORM OF SOUND AND VIDEO RECORDINGS; ELECTRONIC GAMES SERVICES PROVIDED BY MEANS OF THE INTERNET, NAMELY, PROVIDING ONLINE COMPUTER GAMES; ONLINE ELECTRONIC PUBLICATIONS, NAMELY, PROVIDING NON-DOWNLOADABLE ELECTRONIC PUBLICATIONS IN THE NATURE OF CARTOONS IN THE FIELD OF CHILDREN'S ENTERTAINMENT (U.S. CLS. 100, 101 AND 107).

SCOTT BIBB, EXAMINING ATTORNEY

SN 85-123,166. PARMAR, SANTOS, SAN LEANDRO, CA. FILED 9-3-2010.

SIKANDAR

THE MARK CONSISTS OF STANDARD CHARACTERS WITHOUT CLAIM TO ANY PARTICULAR FONT, STYLE, SIZE, OR COLOR.

CLASS 29—MEATS AND PROCESSED FOODS

FOR DRIED LENTILS; DRIED BEANS; PREPACKAGED MEALS CONSISTING PRIMARILY OF MEAT, FISH, POULTRY, OR VEGETABLES; FROZEN VEGETABLES; FROZEN MEATS; PICKLES; SNACK FOODS, NAMELY, FRUIT-BASED SNACK FOODS, NUT-BASED SNACK FOODS, POTATO-BASED SNACK FOODS, SOY-BASED SNACK FOODS, VEGETABLE-BASED SNACK FOODS, AND DAIRY-BASED SNACK FOODS EXCLUDING ICE CREAM, ICE MILK AND FROZEN YOGURT (U.S. CL. 46).

CLASS 30—STAPLE FOODS

FOR RICES; SPICES; PROCESSED HERBS; PREPACKAGED MEALS CONSISTING PRIMARILY OF PASTA OR RICE; TEA; COFFEE; FLOUR; MASALA POWDER AND SPICES; MASALA FOOD MIXES IN THE NATURE OF MIXES OF MASALA SPICES FOR USE IN COOKING FOOD; SNACK FOODS, NAMELY, CEREAL-BASED SNACK FOODS, CORN-BASED SNACK FOODS, GRAIN-BASED SNACK FOODS, MULTIGRAIN-BASED SNACK FOODS, RICE-BASED SNACK FOODS, WHEAT-BASED SNACK FOODS, RICE FLOUR-BASED SNACK FOODS (U.S. CL. 46).

CLASS 35—ADVERTISING AND BUSINESS

FOR RETAIL GROCERY STORES (U.S. CLS. 100, 101 AND 102).

LAURA HAMMEL, EXAMINING ATTORNEY

SN 85-124,797. SWING CORPORATION, OHTA-KU, JAPAN, FILED 9-8-2010.

SWING

THE MARK CONSISTS OF STANDARD CHARACTERS WITHOUT CLAIM TO ANY PARTICULAR FONT, STYLE, SIZE, OR COLOR.

OWNER OF JAPAN REG. NO. 5433689, DATED 8-19-2011, EXPIRES 8-19-2021.

CLASS 35—ADVERTISING AND BUSINESS

FOR OPERATION OF WATERWORKS FACILITIES AND SEWAGE FACILITIES FOR OTHERS; OPERATION OF SLUDGE DISPOSAL FACILITIES FOR OTHERS; OPERATION OF WASTE DISPOSAL FACILITIES FOR OTHERS (U.S. CLS. 100, 101 AND 102).

CLASS 37—CONSTRUCTION AND REPAIR

FOR CONSTRUCTION OF BUILDINGS; BUILDING CONSTRUCTION SUPERVISION; CONSTRUCTION CONSULTANCY SERVICES; CONSTRUCTION OF WATER TREATMENT FACILITIES; REPAIR AND MAINTENANCE OF WATER TREATMENT FACILITIES AND WATER TREATMENT APPARATUS; REPAIR AND MAINTENANCE OF WATERWORKS FACILITIES AND SEWAGE FACILITIES; REPAIR AND MAINTENANCE OF WASTEWATER TREATMENT APPARATUS; REPAIR AND MAINTENANCE OF SLUDGE DISPOSAL FACILITIES AND SLUDGE DISPOSAL EQUIPMENT; REPAIR AND MAINTENANCE OF WASTE DISPOSAL FACILITIES AND WASTE DISPOSAL MACHINES (U.S. CLS. 100, 103 AND 106).

CLASS 40—MATERIAL TREATMENT

FOR WATER TREATING; WATER TREATMENT AND PURIFICATION; DESTRUCTION OF WASTE AND TRASH; WASTE MANAGEMENT (U.S. CLS. 100, 103 AND 106).

CLASS 42—SCIENTIFIC AND COMPUTER SERVICES

FOR CONSTRUCTION DRAFTING; ARCHITECTURAL CONSULTATION; ENGINEERING; DESIGN AND ENGINEERING OF WATER TREATMENT FACILITIES; DESIGN AND ENGINEERING OF WATERWORKS FACILITIES AND SEWAGE PLANTS; DESIGN AND ENGINEERING OF SLUDGE DISPOSAL FACILITIES; DESIGN AND ENGINEERING OF WASTE DISPOSAL FACILITIES; DESIGNING OF WATER TREATMENT APPARATUS; DESIGNING OF WASTEWATER TREATMENT APPARATUS; DESIGNING OF SLUDGE DISPOSAL EQUIPMENT; DESIGNING OF WASTE DISPOSAL MACHINES; DESIGNING OF MACHINES, APPARATUS, INSTRUMENTS, AND PARTS THEREFOR OR SYSTEM COMPOSED OF SUCH MACHINES, APPARATUS AND INSTRUMENTS; ENVIRONMENTAL ASSESSMENT SERVICES (U.S. CLS. 100 AND 101).

CHRISIE B. KING, EXAMINING ATTORNEY

SN 85-125,381. CORVEL CORPORATION, IRVINE, CA. FILED 9-8-2010.

INSIGHT. IN TOUCH.

THE MARK CONSISTS OF STANDARD CHARACTERS WITHOUT CLAIM TO ANY PARTICULAR FONT, STYLE, SIZE, OR COLOR.

CLASS 35—ADVERTISING AND BUSINESS

FOR HEALTHCARE MANAGEMENT SERVICES, NAMELY, MEDICAL COST MANAGEMENT AND PROVIDING HEALTHCARE SERVICE QUALITY INFORMATION FOR BUSINESS PURPOSES, MEDICAL CASE MANAGEMENT IN THE NATURE OF MEDICAL REFERRALS, MEDICAL APPOINTMENT SCHEDULING SERVICES, MEDICAL PROVIDER REIMBURSEMENT REVIEW SERVICES, HEALTH CARE UTILIZATION AND REVIEW AND EMPLOYMENT COUNSELING; MEDICAL BILLING SUPPORT SERVICES, NAMELY, PERFORMING COST ANALYSES, BILLING SERVICES IN THE NATURE OF GENERATING AND TRACKING INVOICES, COMPUTERIZED FILE MANAGEMENT IN THE NATURE OF GENERATING AND MAINTAINING MEDICAL BILLING CASE FILES, PERSONNEL MANAGEMENT IN THE NATURE OF REPORTING EMPLOYEE ABSENCES; PATIENT CARE MANAGEMENT SERVICES RELATED TO PROVISION OF MEDICAL AND INJURY ASSESSMENT SERVICES, NAMELY, COST MANAGEMENT, MANAGED CARE PRE-CERTIFICATION SERVICES, COORDINATION OF SECOND OPINIONS IN THE NATURE OF APPOINTMENT SCHEDULING, COORDINATION OF MEDICAL EQUIPMENT RENTALS AND ANCILLARY SUPPLIES, BILL AUDIT AND REVIEW SERVICES; APPOINTMENT SCHEDULING SERVICES, NAMELY, SCHEDULING AND COORDINATING CHIROPRACTIC EXAMS, PHYSICAL THERAPY SESSIONS AND MEDICAL EXAMS AND APPOINTMENTS; HOSPITAL, MEDICAL FACILITY, MEDICAL AND THERAPY BILL AUDITING; ONLINE COST AND PRICE ANALYSIS, UTILIZATION AND REVIEW OF HEALTH CARE BILLS AND CLAIMS; PROMOTING THE GOODS OF OTHERS BY PROVIDING A WEB SITE FEATURING LINKS TO THE RETAIL WEB SITES OF OTHERS OFFERING DISCOUNTED PHARMACEUTICALS; MAIL ORDER AND RETAIL STORE SERVICES AND WHOLESALE ORDERING SERVICES FEATURING PHARMACEUTICALS; BUSINESS ADMINISTRATION IN THE HEALTHCARE FIELD, NAMELY, BUSINESS OPERATION, MANAGEMENT, PLANNING AND PROMOTION OF REGIONAL HEALTH CARE PROVIDER NETWORKS OF OTHERS; MEDICAL CASE MANAGEMENT FOR BUSINESS PURPOSES, NAMELY, ELECTRONIC DATA PROCESSING OF PATIENT HEALTH CARE INFORMATION; HEALTH CARE COST

REVIEW, NAMELY, MEDICAL PROVIDER REIMBURSEMENT REVIEW SERVICES; ACCOUNT AUDITING OF MEDICAL PROVIDER REIMBURSEMENT PROGRAMS OF OTHERS; HEALTH CARE COST REVIEW, NAMELY, MEDICAL AND THERAPY BILL AUDIT SERVICES; HOSPITAL INPATIENT AND OUTPATIENT AUTOMATED BILL REVIEW AND COST CONTAINMENT SERVICES; COMPUTERIZED MEDICAL REVIEW SERVICES, NAMELY, IDENTIFYING MEDICAL CLAIMS NEEDING MEDICAL COST MANAGEMENT OR REVIEW FOR OVER UTILIZATION OF MEDICAL SERVICES AND CASE BY CASE FEE NEGOTIATION SERVICES, FOR THIRD PARTIES; CASE BY CASE MEDICAL AND THERAPY FEE NEGOTIATION SERVICES, FOR THIRD PARTIES; MEDICAL AND THERAPY COST CONTAINMENT SERVICES; PROVIDING AN ON-LINE DIRECTORY INFORMATION SERVICE FEATURING INFORMATION RELATING TO HEALTH CARE PLANS, NAMELY, HEALTHCARE NETWORK CONTACT INFORMATION, LISTINGS OF PARTICIPATING HEALTH CARE PROVIDERS INCLUDING THEIR CREDENTIALS, AND LISTINGS OF PHARMACIES OFFERING DISCOUNT PRESCRIPTIONS; ONLINE PERSONNEL MANAGEMENT SERVICES, NAMELY, MANAGING EMPLOYEE DISABILITY, MEDICAL HISTORY AND VOCATIONAL RECORDS FOR BUSINESS PURPOSES; COMPUTERIZED ONLINE ORDERING SERVICES IN THE FIELD OF MEDICAL EQUIPMENT AND SUPPLIES FOR EMPLOYEE DISABILITY MANAGEMENT AND REHABILITATION; ASSET MANAGEMENT SERVICES, NAMELY, TRACKING AND MONITORING THE USE OF MEDICAL EQUIPMENT AND SUPPLIES BY DISABLED EMPLOYEES FOR COMMERCIAL, NON-MEDICAL PURPOSES; BUSINESS ADMINISTRATION FOR OTHERS IN THE HEALTHCARE FIELD, NAMELY, BUSINESS OPERATION, MANAGEMENT AND PLANNING OF REGIONAL HEALTH CARE NETWORKS OF PHYSICIANS, MEDICAL IMAGING SERVICES, PHYSICAL THERAPISTS, CHIROPRACTORS, HOSPITALS AND OTHER HEALTH CARE PROVIDERS; MANAGED CARE SERVICES, NAMELY, ELECTRONIC PROCESSING OF HEALTH CARE INFORMATION FOR OTHERS FOR THE PURPOSE OF FACILITATING AND COORDINATING PROVISION OF VOCATIONAL REHABILITATION SERVICES, EARLY HEALTH CARE INTERVENTION PROGRAMS AND LONG TERM HEALTH CARE PLANNING; HEALTH CARE COST REVIEW, NAMELY, MEDICAL PROVIDER REIMBURSEMENT REVIEW SERVICES AND PREFERRED PROVIDER ORGANIZATION BUSINESS MANAGEMENT SERVICES FOR WORKERS' COMPENSATION, AUTO LIABILITY AND GROUP HEALTH INSURANCE COVERAGES; MEDICAL COST MANAGEMENT, NAMELY, IN NETWORK AND OUT OF NETWORK MEDICAL BILL AUDIT SERVICE FOR ALL TYPES OF MEDICAL BILLS IN RELATION TO ESTABLISHED FEE SCHEDULES, USUAL AND CUSTOMARY COSTS AND PREFERRED PROVIDER ORGANIZATION DISCOUNTS; COMPUTERIZED MEDICAL REVIEW SERVICES, NAMELY, IDENTIFYING MEDICAL CLAIMS NEEDING MEDICAL COST MANAGEMENT OR REVIEW FOR OVER UTILIZATION OF MEDICAL SERVICES; RETROSPECTIVE UTILIZATION REVIEW SERVICES FOR ALL MEDICAL BILLS; MANAGED CARE SERVICES, NAMELY, COORDINATING NECESSARY MANAGED CARE REQUIREMENTS FOR INDIVIDUALS IN CONNECTION WITH SHORT AND LONG TERM DISABILITY, HEALTH, ACCIDENT, AUTO LIABILITY AND WORKERS' COMPENSATION INSURANCE CLAIMS (U.S. CLS. 100, 101 AND 102).

FIRST USE 7-31-2004; IN COMMERCE 7-31-2004.

CLASS 36—INSURANCE AND FINANCIAL

FOR ADMINISTERING PRE-NEGOTIATED PREFERRED PROVIDER RATES IN THE FIELD OF HEALTH CARE; ONLINE HEALTH INSURANCE CLAIMS MANAGEMENT, NAMELY, INSURANCE CLAIMS ADMINISTRATION AND PROCESSING; ONLINE MEDICAL BILL PAYMENT SERVICES; WORKERS' COMPENSATION CLAIM SUBMISSION AND FIRST NOTICE OF LOSS PROCESSING SERVICES; PROCESSING INFORMATION PROVIDED BY EMPLOYERS FOR WORKERS' COMPENSATION CLAIMS; CLAIMS ADMINISTRATION IN THE FIELD OF WORKERS' COMPENSATION, NAMELY, AUTOMATED PREPARATION AND COMPLETION OF CLAIMS (U.S. CLS. 100, 101 AND 102).

FIRST USE 7-31-2004; IN COMMERCE 7-31-2004.

CLASS 44—MEDICAL, BEAUTY AND AGRICULTURAL SERVICES

FOR MEDICAL DIAGNOSTIC TESTING, MONITORING AND REPORTING SERVICES; MEDICAL CASE MANAGEMENT SERVICES IN THE NATURE OF MAINTAINING PATIENT MEDICAL RECORDS AND FILES; MEDICAL CASE MANAGEMENT IN THE NATURE OF HEALTH CARE AND INFORMATION SERVICES PROVIDED VIA TELEPHONE OR OTHER MEANS OF TELECOMMUNICATION, NAMELY, PROVIDING AND ANALYZING PATIENT CARE INFORMATION AND PROVIDING MEDICAL INFORMATION AND MEDICAL ANALYSIS OF PATIENT CARE INFORMATION FOR THE PURPOSE OF COORDINATING MEDICAL CARE CONSISTENT WITH LEGAL CLAIMS AND MONITORING PATIENT CARE OUTCOMES (U.S. CLS. 100 AND 101).

FIRST USE 7-31-2004; IN COMMERCE 7-31-2004.

CLASS 45—PERSONAL AND LEGAL SERVICES

FOR PATIENT CASE MANAGEMENT SERVICES, NAMELY, COORDINATING NECESSARY MEDICAL SERVICES AND INSURANCE SERVICES FOR INJURED OR SICK PATIENTS (U.S. CLS. 100 AND 101).

FIRST USE 7-31-2004; IN COMMERCE 7-31-2004.
STEVEN PEREZ, EXAMINING ATTORNEY

SN 85-126,009. FUJIFILM CORPORATION, MINATO-KU, TOKYO, JAPAN, FILED 9-9-2010.

CELFOCUS

THE MARK CONSISTS OF STANDARD CHARACTERS WITHOUT CLAIM TO ANY PARTICULAR FONT, STYLE, SIZE, OR COLOR.

PRIORITY CLAIMED UNDER SEC. 44(D) ON JAPAN APPLICATION NO. 2010-029290, FILED 4-13-2010, REG. NO. 5353088, DATED 9-10-2010, EXPIRES 9-10-2020.

CLASS 1—CHEMICALS

FOR CHEMICAL POWDERS AND EMULSIFIERS FOR USE IN THE MANUFACTURE OF HEALTH FOODS AND SUPPLEMENTS; CHEMICAL POWDERS AND EMULSIFIERS FOR USE IN THE MANUFACTURE OF COSMETICS; CHEMICALS FOR USE IN THE MANUFACTURE OF PHARMACEUTICAL PREPARATIONS; CHEMICAL PREPARATIONS FOR GENERAL INDUSTRIAL MANUFACTURING (U.S. CLS. 1, 5, 6, 10, 26 AND 46).

CLASS 3—COSMETICS AND CLEANING PREPARATIONS

FOR COSMETICS; NON-MEDICATED TOILETRIES; SOAPS; DETERGENTS FOR HOUSEHOLD USE; DENTIFRICES, FRAGRANCES AND PERFUMERY, INCENSES; FALSE NAILS; FALSE EYELASHES; ANTI-STATIC PREPARATIONS FOR HOUSEHOLD PURPOSES; DEGREASING PREPARATIONS FOR HOUSEHOLD PURPOSES; RUST REMOVING PREPARATIONS; STAIN REMOVING PREPARATIONS; FABRIC SOFTENERS FOR LAUNDRY USE; LAUNDRY BLEACHES (U.S. CLS. 1, 4, 6, 50, 51 AND 52).

CLASS 5—PHARMACEUTICALS

FOR PHARMACEUTICAL PREPARATIONS, NAMELY, CENTRAL NERVOUS SYSTEM AGENTS, PERIPHERAL NERVOUS SYSTEM AGENTS, SENSORY ORGAN AGENTS, MISCELLANEOUS NERVOUS SYSTEM AND SENSORY ORGAN AGENTS, CARDIOVASCULAR AGENTS, RESPIRATORY ORGAN AGENTS, DIGESTIVE ORGAN AGENTS, HORMONES, UROGENITAL AND ANAL ORGAN AGENTS, EPIDERMIDES, DENTAL PREPARATIONS, MISCELLANEOUS ORGAN AGENTS, VITAMINS, NUTRIENTS, TONICS, BLOOD AND BODY FLUID AGENTS, DIALYSIS AGENTS, MISCELLANEOUS METABOLISM AGENTS, CELLULAR FUNCTION ACTIVATING AGENTS, ANTINEOPLASTICS, RADIOACTIVE DRUGS, ALLERGIC AGENTS, MISCELLANEOUS CELLULAR FUNCTION AGENTS, CRUDE DRUGS AND TRADITIONAL CHINESE MEDICINES, ANTIBIOTICS, CHEMOTHERAPEUTICS, BIOLOGICAL PREPARATIONS, PARASITICS (SYSTEMIC), PATHOGENIC ORGANISM AGENTS, DISPENSING MEDICINES, INTRACORPOREAL DIAGNOSTIC AGENTS, PUBLIC HEALTH AGENTS, EXTRACORPOREAL DIAGNOSTIC AGENTS, NON-MAIN THERAPEUTIC PURPOSE AGENTS, ALKALOIDAL NARCOTICS, NON-ALKALOIDAL NARCOTICS AND MISCELLANEOUS NARCOTICS; SANITARY PREPARATIONS FOR MEDICAL USE; SANITARY MASKS FOR MEDICAL PURPOSES; DRUG DELIVERY AGENTS IN THE FORM OF PHARMACEUTICAL WAFERS AND GELATIN-STARCH FILMS FOR PROVIDING CONTROLLED RELEASE OF THE ACTIVE INGREDIENTS FOR A WIDE VARIETY OF PHARMACEUTICALS; GAUZE; EMPTY CAPSULES FOR PHARMACEUTICALS; EYE PATCHES FOR MEDICAL PURPOSES; BANDAGES FOR SKIN WOUNDS FOR USE ON THE EAR; SANITARY PADS; MENSTRUATION TAMPONS; SANITARY NAPKINS; SANITARY PANTIES; COTTON FOR MEDICAL PURPOSES; BANDAGES FOR SKIN WOUNDS, MEDICAL PLASTERS, MEDICAL DRESSINGS; MEDICAL DRESSING IN LIQUID FORM, MEDICAL DRESSING CONTAINING COLLODION FOR PHARMACEUTICAL PURPOSES; BREAST-NURSING PADS; DENTAL COMPOSITE MATERIALS; INCONTINENCE DIAPERS; DIETIC LACTIC SUGAR FOR MEDICAL USE; POWDERED MILK FOR INFANTS; NUTRITIONAL SUPPLEMENTS IN TABLET FORM, CAPSULE FORM, SOFT CAPSULE FORM, FINE POWDER FORM, POWDER FORM, GRANULE FORM, PILL FORM, LIQUID FORM, PASTE FORM, GEL FORM, AND SOLID FORM CONTAINING ASTAXANTHIN AS A PRINCIPAL INGREDIENT; NUTRITIONAL SUPPLEMENTS IN TABLET FORM, CAPSULE FORM, SOFT CAPSULE FORM, FINE POWDER FORM, POWDER FORM, GRANULE FORM, PILL FORM, LIQUID FORM, PASTE FORM, GEL FORM, AND SOLID FORM CONTAINING CERAMIDE AS A PRINCIPAL INGREDIENT; NUTRITIONAL SUPPLEMENTS IN TABLET FORM, CAPSULE FORM, SOFT CAPSULE FORM, FINE POWDER FORM, POWDER FORM, GRANULE FORM, PILL FORM, LIQUID FORM, PASTE FORM, GEL FORM, AND SOLID FORM CONTAINING LYCOPENE AS A PRINCIPAL INGREDIENT; NUTRITIONAL SUPPLEMENTS IN TABLET FORM, CAPSULE FORM, SOFT CAPSULE FORM, FINE POWDER FORM, POWDER FORM, GRANULE FORM, PILL FORM, LIQUID FORM, PASTE FORM, GEL FORM, AND SOLID FORM CONTAINING VITAMIN E AS A PRINCIPAL INGREDIENT; NUTRITIONAL SUPPLEMENTS IN TABLET FORM, CAPSULE FORM, SOFT CAPSULE FORM, FINE POWDER FORM, POWDER FORM, GRANULE FORM, PILL FORM, LIQUID FORM, PASTE FORM, GEL FORM, AND SOLID FORM CONTAINING VITAMIN C AS A PRINCIPAL INGREDIENT; NUTRITIONAL SUPPLEMENTS IN TABLET FORM,

CAPSULE FORM, SOFT CAPSULE FORM, FINE POWDER FORM, POWDER FORM, GRANULE FORM, PILL FORM, LIQUID FORM, PASTE FORM, GEL FORM, AND SOLID FORM CONTAINING SELENIUM YEAST AS A PRINCIPAL INGREDIENT; NUTRITIONAL SUPPLEMENTS IN TABLET FORM, CAPSULE FORM, SOFT CAPSULE FORM, FINE POWDER FORM, POWDER FORM, GRANULE FORM, PILL FORM, LIQUID FORM, PASTE FORM, GEL FORM, AND SOLID FORM CONTAINING ZINC YEAST AS A PRINCIPAL INGREDIENT; NUTRITIONAL SUPPLEMENTS IN TABLET FORM, CAPSULE FORM, SOFT CAPSULE FORM, FINE POWDER FORM, POWDER FORM, GRANULE FORM, PILL FORM, LIQUID FORM, PASTE FORM, GEL FORM, AND SOLID FORM CONTAINING SALACIA EXTRACT POWDER AS A PRINCIPAL INGREDIENT; NUTRITIONAL SUPPLEMENTS IN TABLET FORM, CAPSULE FORM, SOFT CAPSULE FORM, FINE POWDER FORM, POWDER FORM, GRANULE FORM, PILL FORM, LIQUID FORM, PASTE FORM, GEL FORM, AND SOLID FORM CONTAINING CHITOSAN AS A PRINCIPAL INGREDIENT; NUTRITIONAL SUPPLEMENTS IN TABLET FORM, CAPSULE FORM, SOFT CAPSULE FORM, FINE POWDER FORM, POWDER FORM, GRANULE FORM, PILL FORM, LIQUID FORM, PASTE FORM, GEL FORM, AND SOLID FORM CONTAINING APPLE POLYPHENOL AS A PRINCIPAL INGREDIENT; NUTRITIONAL SUPPLEMENTS IN TABLET FORM, CAPSULE FORM, SOFT CAPSULE FORM, FINE POWDER FORM, POWDER FORM, GRANULE FORM, PILL FORM, LIQUID FORM, PASTE FORM, GEL FORM, AND SOLID FORM CONTAINING TEA CATECHIN AS A PRINCIPAL INGREDIENT; NUTRITIONAL SUPPLEMENTS IN TABLET FORM, CAPSULE FORM, SOFT CAPSULE FORM, FINE POWDER FORM, POWDER FORM, GRANULE FORM, PILL FORM, LIQUID FORM, PASTE FORM, GEL FORM, AND SOLID FORM CONTAINING CHROMIUM YEAST AS A PRINCIPAL INGREDIENT (U.S. CLS. 6, 18, 44, 46, 51 AND 52).

CLASS 35—ADVERTISING AND BUSINESS

FOR RETAIL STORE SERVICES OR WHOLESALE STORE SERVICES FOR PHARMACEUTICALS, SANITARY PREPARATIONS AND MEDICAL SUPPLIES; RETAIL STORE SERVICES OR WHOLESALE STORE SERVICES FEATURING COSMETICS AND TOILETRIES; RETAIL STORE SERVICES OR WHOLESALE STORE SERVICES FEATURING PROCESSED FOODS; ONLINE RETAIL STORE SERVICES AND WHOLESALE STORE SERVICES FEATURING PHARMACEUTICALS, SANITARY PREPARATIONS AND MEDICAL SUPPLIES; ONLINE RETAIL STORE SERVICES AND WHOLESALE STORE SERVICES FEATURING COSMETICS AND TOILETRIES; ONLINE RETAIL STORE SERVICES AND WHOLESALE STORE SERVICES FEATURING PROCESSED FOODS; ADVERTISING IN WEBSITES ON THE INTERNET; PROVIDING BUSINESSES INFORMATION THROUGH WEBSITES ON THE INTERNET; PROVIDING CONSUMER PRODUCTS INFORMATION THROUGH WEBSITES ON THE INTERNET (U.S. CLS. 100, 101 AND 102).

BARBARA BROWN, EXAMINING ATTORNEY

SN 85-126,437. MERIT TRAVEL VENTURES INC., TORONTO, ONTARIO, CANADA, FILED 9-9-2010.



NO CLAIM IS MADE TO THE EXCLUSIVE RIGHT TO USE "TRAVEL", APART FROM THE MARK AS SHOWN.

THE MARK CONSISTS OF THE WORDS "TRAVEL CUTS" IN ALL UPPER-CASE LETTERS, WRITTEN IN A SINGLE HORIZONTAL LINE. THE MARK INCLUDES A DESIGN ELEMENT TO THE LEFT OF THE WORDS. THE DESIGN ELEMENT CONSISTS OF FOUR OUTWARD-FACING ARROWHEADS POSITIONED ALONG THE CORNERS OF A BLANK SQUARE.

CLASS 35—ADVERTISING AND BUSINESS

FOR TRAVEL MANAGEMENT SERVICES (U.S. CLS. 100, 101 AND 102).

FIRST USE 0-0-1974; IN COMMERCE 8-0-2002.

CLASS 36—INSURANCE AND FINANCIAL

FOR INSURANCE AGENCY SERVICES IN THE FIELD OF TRAVEL INSURANCE (U.S. CLS. 100, 101 AND 102).

FIRST USE 0-0-1974; IN COMMERCE 8-0-2002.

CLASS 39—TRANSPORTATION AND STORAGE

FOR TRAVEL AGENCY SERVICES, NAMELY, MAKING AND CONFIRMING RESERVATIONS AND BOOKINGS FOR TRANSPORTATION BY AIR, LAND AND SEA TRAVEL; ARRANGING OF TOURS; CAR RENTAL BOOKING SERVICES; TRAVEL CONSULTING SERVICES; PROVIDING INFORMATION REGARDING TRAVEL AND BUDGET TRAVEL SERVICES; PROVIDING A WEBSITE FEATURING INFORMATION REGARDING TRAVEL AND BUDGET TRAVEL; TRAVEL PLANNING, NAMELY, PLANNING OF TRAVEL ITINERARIES; TRAVEL INFORMATION SERVICES, NAMELY, PROVIDING INFORMATION AND ADVICE REGARDING TRAVEL AND BUDGET TRAVEL (U.S. CLS. 100 AND 105).

FIRST USE 0-0-1974; IN COMMERCE 8-0-2002.

CLASS 41—EDUCATION AND ENTERTAINMENT

FOR ENTERTAINMENT AND EDUCATIONAL SERVICES, NAMELY, THE PRESENTATION OF ONGOING SHOWS, SLIDESHOW PRESENTATIONS AND LECTURES IN THE FIELD OF TRAVEL (U.S. CLS. 100, 101 AND 107).

FIRST USE 0-0-1974; IN COMMERCE 8-0-2002.

CLASS 43—HOTEL AND RESTAURANT SERVICES

FOR TRAVEL AGENCY SERVICES, NAMELY, ACCOMMODATION BOOKING SERVICES, NAMELY, AGENCY SERVICES FOR THE RESERVATION OF TEMPORARY ACCOMMODATION (U.S. CLS. 100 AND 101).

FIRST USE 0-0-1974; IN COMMERCE 8-0-2002.

ERIN FALK, EXAMINING ATTORNEY

SN 85-127,929. MATTEL, INC., EL SEGUNDO, CA. FILED 9-13-2010.

SO COOL. SO YOU.

THE MARK CONSISTS OF STANDARD CHARACTERS WITHOUT CLAIM TO ANY PARTICULAR FONT, STYLE, SIZE, OR COLOR.

CLASS 9—ELECTRICAL AND SCIENTIFIC APPARATUS

FOR ELECTRONIC DEVICES FEATURING VOICE RECORDATION AND RECOGNITION PROPERTIES (U.S. CLS. 21, 23, 26, 36 AND 38).

CLASS 28—TOYS AND SPORTING GOODS

FOR TOYS, GAMES AND PLAYTHINGS, NAMELY, TOY ROBOTS AND ACCESSORIES THEREFOR; TALKING DOLLS AND ACCESSORIES THEREFOR; ELECTRONIC ACTION TOYS WITH AUDIO RECORDING AND RECEIVING COMPONENTS (U.S. CLS. 22, 23, 38 AND 50).

RAUL CORDOVA, EXAMINING ATTORNEY

SN 85-133,349. DAUNAS, YVES, MENESTREAU EN VILLETTE, FRANCE, FILED 9-20-2010.

BAGAIR

THE MARK CONSISTS OF STANDARD CHARACTERS WITHOUT CLAIM TO ANY PARTICULAR FONT, STYLE, SIZE, OR COLOR.

OWNER OF FRANCE REG. NO. 013122419, DATED 9-24-2001, EXPIRES 9-24-2021.

CLASS 6—METAL GOODS

FOR LOCKS, NAMELY, METAL LOCKS AND LOCKS OF IRONMONGERY, METAL LOCKS FOR CHESTS, SAFES, AND WAREHOUSE DOORS, AND METAL DOOR AND WINDOW STOPS (U.S. CLS. 2, 12, 13, 14, 23, 25 AND 50).

CLASS 7—MACHINERY

FOR COMPRESSED AIR MACHINES, HYDRAULIC JACKS, NAMELY, JACKS FOR USE WITH MACHINES AND SAFETY JACKS FOR MACHINES, NAMELY, POWER OPERATED JACKS; MACHINE PARTS, NAMELY, BRAKES FOR ELEVATORS, HOISTS, WINCHES, AND ELECTRIC AND HYDRAULIC CABLE PULLEYS; HYDRAULIC, PNEUMATIC AND MECHANICAL DOOR AND WINDOW OPENERS AND CLOSERS; AND SHOCK ABSORBERS FOR MACHINES; MACHINE AND MECHANICAL PARTS FOR EMERGENCY RESCUE EQUIPMENT, NAMELY, HYDRAULIC VALVE ACTUATORS, LINEAR ACTUATORS, AND PNEUMATIC VALVE ACTUATORS FOR EMERGENCY RESCUE MACHINERY, ELECTRIC SAFETY JACKS FOR ELECTRIC MACHINES (U.S. CLS. 13, 19, 21, 23, 31, 34 AND 35).

CLASS 9—ELECTRICAL AND SCIENTIFIC APPARATUS

FOR ELECTRIC DOOR CLOSERS; ELECTRONIC CONTROLS FOR MACHINES, ENGINES AND MOTORS; SAFETY RELEASE DEVICES FOR ELECTRIC AND ELECTRONIC INSTRUMENTS, NAMELY, CIRCUIT BREAKERS AND ELECTRONIC CONTROLLERS; ALARM ACTUATOR RELEASE VALVES; ELECTRIC CIRCUIT BREAKER ACTUATORS (U.S. CLS. 21, 23, 26, 36 AND 38).

CLASS 12—VEHICLES

FOR ANTI-THEFT DEVICES FOR VEHICLES, NAMELY, ANTI-THEFT LOCKS FOR USE ON VEHICLES STEERING WHEELS, CIRCUIT BREAKERS, TRANSMISSIONS, GEAR BOXES, BRAKES AND ENGINES; COMPONENT PART FOR VEHICLES BRAKING SYSTEMS, NAMELY, BUFFERS AND DAMPERS AND MECHANICAL BLOCKING DEVICES FOR VEHICLE SEATS IN THE NATURE OF SEAT SAFETY HARNESSSES (U.S. CLS. 19, 21, 23, 31, 35 AND 44).

ADA HAN, EXAMINING ATTORNEY

SN 85-133,892. DIGEN PHARMACEUTICALS, GMBH, 1010 WIEN, AUSTRIA, FILED 9-20-2010.

HEALIANCE

THE MARK CONSISTS OF STANDARD CHARACTERS WITHOUT CLAIM TO ANY PARTICULAR FONT, STYLE, SIZE, OR COLOR.

OWNER OF ERPN CMNTY TM OFC REG. NO. 9373929, DATED 1-31-2011, EXPIRES 9-14-2020.

THE WORDING "HEALIANCE" HAS NO MEANING IN A FOREIGN LANGUAGE.

CLASS 1—CHEMICALS

FOR CHEMICAL ADDITIVES FOR USE IN THE MANUFACTURE OF PHARMACEUTICALS AND MEDICINES; ACTIVE CHEMICAL INGREDIENTS FOR USE IN THE MANUFACTURE OF PHARMACEUTICALS FOR TREATING AND PREVENTING DIABETES CAUSED ULCERS, SKIN ULCERS, PEPTIC ULCERS, STOMACH ULCERS, FOOT ULCERS, ISCHEMIC ULCERS, VENOUS ULCERS, VARICOSE ULCERS AND VASCULAR ULCERS; DIAGNOSTIC PREPARATIONS FOR CLINICAL OR MEDICAL LABORATORY USE; DIAGNOSTIC REAGENTS FOR CLINICAL OR MEDICAL LABORATORY USE; REAGENTS FOR SCIENTIFIC OR MEDICAL RESEARCH USE (U.S. CLS. 1, 5, 6, 10, 26 AND 46).

CLASS 5—PHARMACEUTICALS

FOR PHARMACEUTICALS PREPARATIONS, NAMELY, BIOLOGICAL AND BIOSIMILAR PREPARATIONS FOR USE IN THE TREATMENT AND PREVENTION OF DIABETES CAUSED ULCERS, SKIN ULCERS, PEPTIC ULCERS, STOMACH ULCERS, FOOT ULCERS, ISCHEMIC ULCERS, VENOUS ULCERS, VARICOSE ULCERS AND VASCULAR ULCERS; PHARMACEUTICAL PREPARATIONS FOR USE IN THE TREATMENT OF CANCER; NUTRACEUTICALS; PRENATAL VITAMINS; ANTIBACTERIAL PREPARATIONS; ANTIFUNGAL PREPARATIONS; ANTIVIRALS; ANTHELMINTICS; ANTIPROTOZOAL AGENTS; PHARMACEUTICAL PREPARATIONS FOR THE TREATMENT OF ULCERS AND GASTRO-INTESTINAL DISORDERS; PRESCRIPTION MEDICINES, NAMELY, PROKINETICS FOR ENHANCING GASTROINTESTINAL MOTILITY; EMETIC PREPARATIONS; EMETICS; ANALGESICS; ANTI-INFLAMMATORIES; ANTIHISTAMINES; PHARMACEUTICAL PREPARATIONS AND MEDICINES FOR TREATMENT OF HYPERTENSION AND FOR LOWERING LIPID LEVELS, NAMELY, VASODILATORS, VASOCONSTRICTORS, VASCULAR SEDATIVES; DIURETICS; PHARMACEUTICAL PREPARATIONS AND MEDICINES FOR CALCIUM METABOLISM REGULATION; PHARMACEUTICAL MEDICINES FOR INHIBITING PROSTATIC HYPERTROPHY; ANTIDEPRESSANTS (U.S. CLS. 6, 18, 44, 46, 51 AND 52).

CLASS 42—SCIENTIFIC AND COMPUTER SERVICES

FOR RESEARCH IN THE FIELD OF CHEMISTRY; BIOLOGICAL RESEARCH; PHARMACEUTICAL RESEARCH SERVICES (U.S. CLS. 100 AND 101).
BARBARA A. GOLD, EXAMINING ATTORNEY

SN 85-140,870. FABRIKA, INC., MIAMI, FL. FILED 9-29-2010.

FABRIKA

THE MARK CONSISTS OF STANDARD CHARACTERS WITHOUT CLAIM TO ANY PARTICULAR FONT, STYLE, SIZE, OR COLOR.

CLASS 35—ADVERTISING AND BUSINESS

FOR ADVERTISING AND PUBLICITY SERVICES, NAMELY, PROMOTING THE GOODS, SERVICES, BRAND IDENTITY AND COMMERCIAL INFORMATION AND NEWS OF THIRD PARTIES THROUGH PRINT, AUDIO, VIDEO, DIGITAL AND ON-LINE MEDIUM; ADVERTISING, PROMOTION, AND MARKETING SERVICES IN THE NATURE OF PRINT, AUDIO, VIDEO, DIGITAL AND ON-LINE MEDIUM PROMOTIONAL ACTIVITIES FOR THIRD PARTIES; ART GALLERIES; ART GALLERY SERVICES (U.S. CLS. 100, 101 AND 102).
FIRST USE 9-15-2001; IN COMMERCE 9-15-2001.

CLASS 41—EDUCATION AND ENTERTAINMENT

FOR PROVIDING FACILITIES FOR PRODUCING VIDEO, CINEMA AND PHOTOGRAPHY PRODUCTIONS; PROVIDING ON-LINE NEWSLETTERS IN THE FIELD OF ART, ART GALLERIES, MUSIC, SOCIAL FUNCTIONS, VIDEO WORK, PHOTOGRAPHY, CINEMA WORK, RECORDING WORK AND STUDIOS, AND SOCIAL EVENTS; RECORDING STUDIO SERVICES; RECORDING STUDIOS (U.S. CLS. 100, 101 AND 107).
FIRST USE 9-15-2001; IN COMMERCE 9-15-2001.
GEORGE LORENZO, EXAMINING ATTORNEY

SN 85-142,309. SEALED AIR CORPORATION (US), ELMWOOD PARK, NJ. FILED 9-30-2010.

CO-PACKER CONNECTION

THE MARK CONSISTS OF STANDARD CHARACTERS WITHOUT CLAIM TO ANY PARTICULAR FONT, STYLE, SIZE, OR COLOR.

CLASS 35—ADVERTISING AND BUSINESS

FOR ADVISORY SERVICES FOR IDENTIFICATION AND COMPILATION OF PERFORMANCE CAPABILITIES OF PACKAGING CONTRACT MANUFACTURERS WITH THE AID OF ELECTRONIC DATABASES, NAMELY, PROVIDING A SEARCHABLE INTERNET DATABASE OF PACKAGING CONTRACT MANUFACTURERS WITH THE PURPOSE OF MATCHING BUYERS WITH SELLERS OF PACKAGING SERVICES; ADVISORY SERVICES IN THE NATURE OF PROVIDING CONSUMER PRODUCT INFORMATION IN THE FIELD OF PACKAGING EQUIPMENT AND MARKET UPDATES UTILIZING MARKETING REPORTS AND STUDIES IN THE PACKAGING INDUSTRY AND COMMUNICATIONS IN THE NATURE OF MARKETING THE PACKAGING SERVICES OF OTHERS THROUGH ALL PUBLIC COMMUNICATIONS MEANS; CONSULTING SERVICES IN THE FIELD OF PACKAGING, NAMELY, IDENTIFICATION AND COMMUNICATION OF QUALIFICATIONS OF PACKAGING CONTRACT MANUFACTURERS IN THE NATURE OF CONNECTING BUYERS WITH SELLERS OF PACKAGING SERVICES BY MATCHING THE QUALIFICATIONS OF A SELLER WITH THE NEEDS OF THE BUYER (U.S. CLS. 100, 101 AND 102).

CLASS 42—SCIENTIFIC AND COMPUTER SERVICES

FOR CONSULTING SERVICES IN THE FIELD OF PACKAGING, NAMELY, IDENTIFICATION AND COMMUNICATION OF QUALIFICATIONS OF PACKAGING CONTRACT MANUFACTURERS IN THE NATURE OF EVALUATING PACKAGING CONTRACT MANUFACTURERS TO DETERMINE WHETHER THE ORGANIZATION CONFORMS TO PARTICULAR ESTABLISHED STANDARDS OR QUALIFICATIONS IN THE PACKAGING INDUSTRY (U.S. CLS. 100 AND 101).
CHRISTINA SOBRAL, EXAMINING ATTORNEY

SN 85-143,260. CASTLE & MOSEY II, LLC, CLARENCE, NY. FILED 10-1-2010.

NO CLAIM IS MADE TO THE EXCLUSIVE RIGHT TO USE "COMPANIES", APART FROM THE MARK AS SHOWN.

THE MARK CONSISTS OF THE WORD "THE" PLACED OVER THE COINED WORD "NORTHSTAR", ALL PLACED OVER THE WORD "COMPANIES", ALL IN STYLIZED LETTERING, WITH A SOLID FIVE-POINTED STAR PLACED TO THE UPPER RIGHT OF "THE" AND A SOLID HALF-ARC SYMBOL EXTENDING FROM "THE" TO THE LOWER LEFT OF "COMPANIES".

CLASS 35—ADVERTISING AND BUSINESS

FOR CUSTOMER TELESERVICING SERVICES, NAMELY, OPERATION OF TELEPHONE CALL CENTERS FOR OTHERS (U.S. CLS. 100, 101 AND 102).
FIRST USE 6-0-2005; IN COMMERCE 6-0-2005.

CLASS 36—INSURANCE AND FINANCIAL

FOR DEBT COLLECTION SERVICES (U.S. CLS. 100, 101 AND 102).
FIRST USE 6-0-2010; IN COMMERCE 6-0-2010.
LINDA ESTRADA, EXAMINING ATTORNEY

SN 85-148,208, EDENRED, 92240 MALAKOFF, FRANCE,
FILED 10-8-2010.



PRIORITY CLAIMED UNDER SEC. 44(D) ON FRANCE APPLICATION NO. 10/3732373, FILED 4-22-2010, REG. NO. 10/3732373, DATED 4-22-2010, EXPIRES 4-22-2020.

NO CLAIM IS MADE TO THE EXCLUSIVE RIGHT TO USE "THE TICKET COMPANY", APART FROM THE MARK AS SHOWN.

THE COLOR(S) BLUE AND RED IS/ARE CLAIMED AS A FEATURE OF THE MARK.

THE MARK CONSISTS OF A RED BALL ABOVE A BLUE SHADOW, ALL TO THE LEFT OF THE WORDS "THE TICKET COMPANY" IN BLUE.

CLASS 9—ELECTRICAL AND SCIENTIFIC APPARATUS

FOR ENCODED DISPOSABLE AND RECHARGEABLE MAGNETIC, OPTICAL, MEMORY AND ELECTRONIC CHIP CARDS WITH OR WITHOUT RADIO, INFRARED OR OTHER FREQUENCY CONTACT, FOR PREPAID OR POSTPAID USE, IN THE NATURE OF SMART CARDS CONTAINING PROGRAMMING FOR PHYSICAL ACCESS CONTROL, CONTROL OF ACCESS TO COMPUTER SYSTEMS, AND FOR CONTROLLING AND CHECKING LOYALTY CARDS; SOFTWARE FOR COMMERCIAL ORDER AND PURCHASE PROCESSING; SOFTWARE FOR PROVIDING ACCESS TO AN ELECTRONIC MESSAGING SERVICE; SOFTWARE FOR PROVIDING ACCESS TO A COMPUTER OR DATA TRANSMISSION NETWORK, IN PARTICULAR A WORLDWIDE COMMUNICATIONS NETWORK, SUCH AS THE INTERNET, OR A PRIVATE OR RESTRICTED ACCESS NETWORK, SUCH AS AN INTRANET; DOWNLOADABLE ELECTRONIC PUBLICATIONS IN THE NATURE OF PERIODICALS AND NEWSLETTERS IN THE FIELDS OF FINANCE; PREPAID ENCODED SMART CARDS DESIGNED TO ENHANCE INDIVIDUAL WELL-BEING AND THE PERFORMANCE OF ORGANIZATIONS (U.S. CLS. 21, 23, 26, 36 AND 38).

CLASS 16—PAPER GOODS AND PRINTED MATTER

FOR PRINTED TOKENS FOR USE AS VOUCHERS; CREDIT OR DEBIT CARDS NOT MAGNETICALLY CODED FOR USE IN BUSINESS TRANSACTIONS; COUPONS (U.S. CLS. 2, 5, 22, 23, 29, 37, 38 AND 50).

CLASS 35—ADVERTISING AND BUSINESS

FOR BUSINESS MANAGEMENT, NAMELY, ACCOUNTING AND BUSINESS ADMINISTRATION, BUSINESS DATA ANALYSIS, AND DATA PROCESSING OF DEMATERIALIZED AND SECURE COMMERCIAL INFORMATION RELATING TO THE FIELDS OF THE HOTEL INDUSTRY, RESTAURANTS AND OTHER FOOD PURVEYORS, COMMERCE, BUSINESS AND FINANCE; ADMINISTRATIVE PROCESSING OF PURCHASING ORDERS; BUSINESS ADMINISTRATION AND MANAGEMENT; BUSINESS ADMINISTRATION SERVICES FOR THE ACQUISITION OF GOODS OR SERVICES BY MEANS OF ELECTRONIC CARDS, COUPONS, VOUCHERS OR COUNTERMARKS; PROVIDING ADVICE, CONSULTANCY, INFORMATION, AND EXPERT ANALYSIS IN BUSINESS ORGANISATION AND MANAGEMENT; BUSINESS INFORMATION SERVICES RELATING TO THE DISSEMINATION AND USE OF PREPAID CARDS, GIFT CARDS AND OTHER PAYMENT VOUCHERS; PROVIDING BUSINESS ADMINISTRATIVE ADVICE FOR THE ORGANIZATION OF IN-COMPANY SAVINGS PLANS; PROVIDING STATISTICAL INFORMATION AND EVALUATION FOR BUSINESS OR COMMERCIAL PURPOSES; ADVERTISING, NAMELY, ADVERTISING ON ELECTRONIC AND COMPUTER MEDIA; ORGANISATION OF COMMERCIAL CUSTOMER LOYALTY BUILDING OPERATIONS FOR COMMERCIAL, PROMOTIONAL AND/OR ADVERTISING PURPOSES; PROVIDING ADVICE, ANALYSIS AND EXPERT CONSULTANCY IN THE BUSINESS APPRAISAL OF THE ADMINISTRATIVE MEANS NECESSARY FOR THE MANAGEMENT OF COMMERCIAL ORDERS, THE PROVISION OF MEALS, FOOD PRODUCTS AND DOMESTIC SERVICES (U.S. CLS. 100, 101 AND 102).

CLASS 36—INSURANCE AND FINANCIAL

FOR ADMINISTRATION OF EMPLOYEE FINANCIAL BENEFIT PLANS BY ARRANGING FOR PAYMENT OF THE PROVISION OF MEALS AND FOOD PRODUCTS AND ANY OTHER PRODUCT OR SERVICE BY ISSUING, COMPENSATING, AND REIMBURSING OTHERS FOR THE USE OF VOUCHERS, COUPONS, STUBS, PREPAID OR DEBIT-CREDIT CARDS OR ANY OTHER MEANS OF PAYMENT IN PARTICULAR BY COMPUTER NETWORK; CREDIT CARD SERVICES AND LOYALTY CARD SERVICES, NAMELY, PROVIDING CASH AND OTHER REBATES FOR CREDIT CARD USE AS PART OF A CUSTOMER LOYALTY PROGRAM; FINANCIAL MANAGEMENT OF FINANCIAL ADVANTAGES RELATING TO THE USE OF A LOYALTY CARD AND LOYALTY CARD SERVICES OTHER THAN FOR ADVERTISING PURPOSES ALLOWING THESE ADVANTAGES TO BE CAPITALISED; FINANCIAL AND MONETARY AFFAIRS, NAMELY, FINANCIAL INFORMATION, MANAGEMENT, AND ANALYSIS SERVICES; PROVIDING ADVICE, CONSULTANCY, INFORMATION AND EXPERT ANALYSIS IN THE FINANCIAL FIELD; FINANCING SERVICES FOR THE ACQUISITION OF GOODS OR SERVICES BY MEANS OF ELECTRONIC CARDS, COUPONS, VOUCHERS OR COUNTERMARKS; FINANCIAL ADMINISTRATION INVOLVING THE SETTING UP AND MANAGEMENT OF SAVE-AS-YOU-EARN PLANS; FINANCIAL ADVICE ON THE SETTING UP AND MANAGEMENT OF IN-COMPANY SAVINGS PLANS (U.S. CLS. 100, 101 AND 102).

CLASS 43—HOTEL AND RESTAURANT SERVICES

FOR INFORMATION SERVICES IN THE FIELDS OF HOTEL AND RESTAURANT ACCOMMODATIONS; NURSERIES, DAY NURSERIES, CHILDREN'S CRÈCHES (U.S. CLS. 100 AND 101).

ANN E. SAPPENFIELD, EXAMINING ATTORNEY

SN 85-148,423. INTERNATIONAL PARKING INSTITUTE, FREDERICKSBURG, VA. FILED 10-8-2010.

SN 85-148,884. SURF CREATURES, LLC, SANTA BARBARA, CA. FILED 10-8-2010.

INTERNATIONAL PARKING
INSTITUTE CONFERENCE & EXPO

SURF CREATURES

THE MARK CONSISTS OF STANDARD CHARACTERS WITHOUT CLAIM TO ANY PARTICULAR FONT, STYLE, SIZE, OR COLOR.

NO CLAIM IS MADE TO THE EXCLUSIVE RIGHT TO USE "INSTITUTE" AND "CONFERENCE & EXPO", APART FROM THE MARK AS SHOWN.

SEC. 2(F) AS TO "INTERNATIONAL PARKING INSTITUTE".

CLASS 35—ADVERTISING AND BUSINESS

FOR ARRANGING AND CONDUCTING TRADESHOWS IN THE FIELD OF PARKING AND PARKING OPERATIONS (U.S. CLS. 100, 101 AND 102).

FIRST USE 5-17-2009; IN COMMERCE 5-17-2009.

CLASS 41—EDUCATION AND ENTERTAINMENT

FOR ARRANGING AND CONDUCTING EDUCATIONAL CONFERENCES IN THE FIELD OF PARKING AND PARKING OPERATIONS (U.S. CLS. 100, 101 AND 107).

FIRST USE 5-17-2009; IN COMMERCE 5-17-2009.

LINDSEY RUBIN, EXAMINING ATTORNEY

SN 85-148,742. AMERICAN JEWISH CONGRESS, NEW YORK, NY. FILED 10-8-2010.

AMERICAN JEWISH CONGRESS

THE MARK CONSISTS OF STANDARD CHARACTERS WITHOUT CLAIM TO ANY PARTICULAR FONT, STYLE, SIZE, OR COLOR.

SEC. 2(F).

CLASS 35—ADVERTISING AND BUSINESS

FOR PUBLIC ADVOCACY TO PROMOTE AWARENESS OF JUDAISM (U.S. CLS. 100, 101 AND 102).

FIRST USE 0-0-1918; IN COMMERCE 0-0-1918.

CLASS 36—INSURANCE AND FINANCIAL

FOR CHARITABLE FUNDRAISING SERVICES (U.S. CLS. 100, 101 AND 102).

FIRST USE 0-0-1918; IN COMMERCE 0-0-1918.

REBECCA SMITH, EXAMINING ATTORNEY

THE MARK CONSISTS OF STANDARD CHARACTERS WITHOUT CLAIM TO ANY PARTICULAR FONT, STYLE, SIZE, OR COLOR.

CLASS 24—FABRICS

FOR HOME FURNISHINGS, NAMELY, FURNITURE UPHOLSTERY FABRICS; TAPESTRIES OF TEXTILE; UNFITTED FABRIC FURNITURE COVERS; BATH TOWELS; BEACH TOWELS; CHILDREN'S TOWELS; FACE TOWELS OF TEXTILES; HAND TOWELS; KITCHEN TOWELS; HOODED TOWELS; TOWEL SETS; TOWELS; BLANKET THROWS; BLANKETS FOR OUTDOOR USE; TEXTILE FABRICS FOR HOME AND COMMERCIAL INTERIORS; COTTON BASE MIXED FABRICS; COTTON FABRICS; GAUZE FABRIC; KNITTED FABRICS; MIXED FIBER FABRICS; NYLON FABRICS; POLYESTER FABRICS; RAYON FABRICS; LINEN FABRICS; SEMI-SYNTHETIC FIBER FABRICS; SYNTHETIC FIBER FABRICS; WOOLEN FABRICS; GIFT WRAP OF FABRIC; CURTAINS; DRAPERY; BATH LINEN; DISHCLOTHS; TEXTILE DRAPERIES; DRAPERIES; BED COVERS, PLASTIC TABLE COVERS, TEXTILE TABLE COVERS; SHOWER CURTAINS; WASHCLOTHS; CLOTH FLAGS; CLOTH PENNANTS; PLASTIC PLACE MATS; TEXTILE PLACE MATS; BEDDING, NAMELY, BED SHEETS, BED FLAT SHEETS, FITTED BED SHEET COVERS, BED BLANKETS, CHILDREN'S BED BLANKETS; BED SKIRTS, BED THROWS, BED LINEN, BED SPREADS, BED SHAMS, BED COMFORTERS, PILLOWCASES, PILLOW SHAMS, PILLOW COVERS, PILLOW CASES, PILLOW SLIPCOVERS; DUST RUFFLES; DUVETS; DUVET COVERS; QUILTS AND QUILT COVERS; CHILDREN'S BED SHEETS; CRIB BED SHEETS; CRIB BUMPER; CRIB BUMPER PADS; CRIB CANOPIES; AND CRIB COMFORTERS; MATTRESS COVERLETS; MATTRESS COVERS; MATTRESS PADS; FABRIC WINDOW COVERINGS AND TREATMENTS, NAMELY, CURTAINS, DRAPERIES, SHEERS, SWAGS AND VALANCES; BATH SHEETS; TABLE LINEN, NAMELY, TABLE CLOTHS, TABLE RUNNERS, CLOTH NAPKINS, PLACE MATS, AND COASTERS (U.S. CLS. 42 AND 50).

CLASS 25—CLOTHING

FOR CLOTHING, NAMELY BATHING SUITS, BELTS, BABY BIBS NOT OF PAPER, CLOTH BIBS, CHILDREN'S CLOTH EATING BIBS, BIKINIS, BLOUSES, BOTTOMS, BOXER SHORTS, CARGO PANTS, COATS, COVERALLS, BEACH COVER UPS, CROP TOPS, DRESSES, FLEECE TOPS, FLEECE PULLOVERS, HALTER TOPS, HATS, VISORS, BASEBALL CAPS, BEANIES, BONNETS, HEADBANDS, AND CAPS, HEADWEAR, HOSIERY, JACKETS, JEANS, JUMPERS, JERSEYS, KHAKI PANTS, LOUNGEWEAR, NIGHT SHIRTS, NIGHTGOWNS, OXFORD STYLE SHIRTS, OVERALLS, PAJAMAS, PANTS, POLO SHIRTS, PONCHOS, PULLOVERS, RAIN JACKETS, ROBES, SCARVES, SHIRTS, SHOES, SHORTS, SKIRTS, SLEEPWEAR, SOCKS, SPORTS SHIRTS, SWEATPANTS, SWEAT TOPS, SWEATSHIRTS, SWEATERS, SWIMWEAR, TANK TOPS, TIGHTS, T-SHIRTS, TOPS, TROUSERS, UNDERWEAR, UNDERGARMENTS, WALKING SHORTS, WIND RESISTANT JACKETS AND WIND SHIRTS, FOOTWEAR, SHOES, SANDALS, SLIPPERS, LEATHER BELTS, BEACHWEAR, NAMELY, SWIMWEAR, INFANT WEAR, NAMELY, SHIRTS, PANTS, SLEEPWEAR, TOPS, AND FOOTWEAR, BATHING COVER-UPS (U.S. CLS. 22 AND 39).

DANIEL CAPSHAW, EXAMINING ATTORNEY

SN 85-149,557. WILLOWSFORD, L.L.C., DALLAS, TX. FILED 10-11-2010.

SN 85-152,489. OUR TIME, WASHINGTON, DC. FILED 10-14-2010.

WILLOWSFORD

THE MARK CONSISTS OF STANDARD CHARACTERS WITHOUT CLAIM TO ANY PARTICULAR FONT, STYLE, SIZE, OR COLOR.

CLASS 35—ADVERTISING AND BUSINESS

FOR PROVIDING AN INTERACTIVE REAL ESTATE WEBSITE WHICH PROMOTES RESIDENTIAL HOUSING AND LIVING COMMUNITIES BY CONNECTING BUYERS AND SELLERS AND OFFERING PROSPECTIVE RESIDENTS PROPERTY AND HOME DESCRIPTIONS, PRICE, LOCATION, AND MAPS THAT WOULD BE INFLUENTIAL TO A PROSPECTIVE BUYER MAKING A BUYING DECISION; PROVIDING A WEBSITE FEATURING NEWS AND INFORMATION RELATING TO A RESIDENTIAL COMMUNITY'S FARMER'S MARKET; PROVIDING A WEBSITE FEATURING NEWS AND INFORMATION RELATING TO BUSINESS MANAGEMENT IN THE FIELD OF CONSERVING LAND FOR FISHING AND WILDLIFE; PROVIDING A WEBSITE FEATURING NEWS AND INFORMATION IN THE FIELD OF NATURAL RESOURCE MANAGEMENT; CHARITABLE SERVICES, NAMELY, ORGANIZING AND DEVELOPING PROJECTS TO PROMOTE PUBLIC AWARENESS OF AGRICULTURE AND THE CONSERVATION OF LAND, WILDLIFE AND NATURAL RESOURCES; REAL ESTATE MARKETING SERVICES, NAMELY, ONLINE SERVICES FEATURING THE PROMOTION OF RESIDENTIAL NEW CONSTRUCTION (U.S. CLS. 100, 101 AND 102).

CLASS 36—INSURANCE AND FINANCIAL

FOR REAL ESTATE SERVICES, NAMELY, BROKERAGE, LEASING AND MANAGEMENT OF RESIDENTIAL AND COMMERCIAL PROPERTY; REAL ESTATE PROPERTY MANAGEMENT; REAL ESTATE SERVICES, NAMELY, PROPERTY MANAGEMENT FOR HOMEOWNERS ASSOCIATION; RESIDENTIAL COMMUNITY PROPERTY MANAGEMENT SERVICES; REAL ESTATE LISTING SERVICES; LEASING OF REAL ESTATE TO OTHERS FOR THE PURPOSE OF CULTIVATING THE LAND (U.S. CLS. 100, 101 AND 102).

CLASS 37—CONSTRUCTION AND REPAIR

FOR CONSTRUCTION, REAL ESTATE AND LAND DEVELOPMENT SERVICES, NAMELY, CONSTRUCTION, PLANNING AND LAYING OUT OF RESIDENTIAL AND/OR COMMERCIAL COMMUNITIES HAVING AMENITIES INCLUDING SWIMMING POOLS, FITNESS FACILITIES, NATURE TRAILS, COMMUNITY CENTERS, COMMUNITY GARDENS AND OTHER OUTDOOR FACILITIES; SUBDIVIDING AND DEVELOPING REAL ESTATE PROPERTY FOR OTHERS; CONSULTATION IN BUILDING CONSTRUCTION SUPERVISION (U.S. CLS. 100, 103 AND 106).

CLASS 44—MEDICAL, BEAUTY AND AGRICULTURAL SERVICES

FOR PROVIDING A WEBSITE FEATURING NEWS AND INFORMATION RELATING TO AGRICULTURE (U.S. CLS. 100 AND 101).
DAWN FELDMAN, EXAMINING ATTORNEY

OUR TIME

THE MARK CONSISTS OF STANDARD CHARACTERS WITHOUT CLAIM TO ANY PARTICULAR FONT, STYLE, SIZE, OR COLOR.

CLASS 35—ADVERTISING AND BUSINESS

FOR PROVIDING INFORMATION TO AND FOR YOUNG PEOPLE AGES 18 TO 29 ABOUT THEIR COMMON ECONOMIC INTERESTS; PROVIDING INFORMATION TO AND FOR YOUNG PEOPLE AGES 18 TO 29 ABOUT THEIR COMMON CIVIC INTERESTS, NAMELY, INFORMATION REGARDING POLITICAL ISSUES, KNOWING HOW TO VOTE, AND KNOWING HOW TO REGISTER TO VOTE (U.S. CLS. 100, 101 AND 102).

FIRST USE 8-20-2010; IN COMMERCE 8-20-2010.

CLASS 41—EDUCATION AND ENTERTAINMENT

FOR EDUCATIONAL SERVICES, NAMELY, PROVIDING SEMINARS, CLASSES, WORKSHOPS AND PROGRAMS TO AND FOR YOUNG PEOPLE AGES 18 TO 29 ABOUT THEIR COMMON CIVIC AND ECONOMIC INTERESTS (U.S. CLS. 100, 101 AND 107).

FIRST USE 8-20-2010; IN COMMERCE 8-20-2010.
BRIAN CALLAGHAN, EXAMINING ATTORNEY

SN 85-152,786. THE AMERICAN SOCIETY FOR THE PREVENTION OF CRUELTY TO ANIMALS, NEW YORK, NY. FILED 10-14-2010.

ASPCA KIDS

THE MARK CONSISTS OF STANDARD CHARACTERS WITHOUT CLAIM TO ANY PARTICULAR FONT, STYLE, SIZE, OR COLOR.

OWNER OF U.S. REG. NO. 1,934,584.

NO CLAIM IS MADE TO THE EXCLUSIVE RIGHT TO USE "KIDS", APART FROM THE MARK AS SHOWN.

CLASS 16—PAPER GOODS AND PRINTED MATTER

FOR CHILDREN'S BOOKS, MAGAZINES, POSTERS AND BROCHURES; STATIONERY, NAMELY, PAPER, PENS, PENCILS, NOTEBOOKS, ENVELOPES, NOTE CARDS, GREETING CARDS, POSTCARDS, AND BINDERS; PAPER TOWELS (U.S. CLS. 2, 5, 22, 23, 29, 37, 38 AND 50).

FIRST USE 2-28-2009; IN COMMERCE 2-28-2009.

CLASS 38—COMMUNICATION

FOR PROVIDING ON-LINE FORUMS FOR TRANSMISSION OF MESSAGES TO, AND AMONG, CHILDREN COMPUTER USERS CONCERNING ANIMALS, ANIMAL ADOPTION, ANIMAL BEHAVIOR, ANIMAL CARE, ANIMAL CRUELTY, ANIMAL ENVIRONMENTS, ANIMAL PROTECTION, ANIMAL SHELTERS, ANIMAL WELFARE, ANIMAL VETERINARY SERVICES AND MEDICAL CARE, AND HUMANE ETHICS (U.S. CLS. 100, 101 AND 104).

FIRST USE 4-1-2010; IN COMMERCE 4-1-2010.

SN 85-152,795. THE AMERICAN SOCIETY FOR THE PREVENTION OF CRUELTY TO ANIMALS, NEW YORK, NY. FILED 10-14-2010.

ASPCA KIDS**CLASS 39—TRANSPORTATION AND STORAGE**

FOR PROVIDING A WEB SITE FEATURING INFORMATION FOR CHILDREN IN THE FIELD OF ANIMAL-RESCUE SERVICES (U.S. CLS. 100 AND 105).

FIRST USE 4-1-2010; IN COMMERCE 4-1-2010.

THE MARK CONSISTS OF STANDARD CHARACTERS WITHOUT CLAIM TO ANY PARTICULAR FONT, STYLE, SIZE, OR COLOR.

OWNER OF U.S. REG. NO. 1,934,584.

NO CLAIM IS MADE TO THE EXCLUSIVE RIGHT TO USE "KIDS", APART FROM THE MARK AS SHOWN.

CLASS 41—EDUCATION AND ENTERTAINMENT

FOR PROVIDING NON-DOWNLOADABLE ON-LINE COMPUTER, ELECTRONIC, AND VIDEO GAMES AND INTERACTIVE GAMES; PROVIDING A WEB SITE FEATURING ON-LINE PUBLICATIONS IN THE NATURE OF BROCHURES, FLYERS, ARTICLES, MAGAZINES AND FACT SHEETS FOR CHILDREN IN THE FIELDS OF ANIMALS, ANIMAL ADOPTION, ANIMAL BEHAVIOR, ANIMAL CARE, ANIMAL CRUELTY, ANIMAL ENVIRONMENTS, ANIMAL PROTECTION, ANIMAL SHELTERS, ANIMAL WELFARE, ANIMAL VETERINARY SERVICES AND MEDICAL CARE, AND HUMANE ETHICS; PROVIDING A WEB SITE THAT FEATURES INFORMAL INSTRUCTION FOR CHILDREN AND EDUCATIONAL ACTIVITIES FOR CHILDREN REGARDING ANIMALS, ANIMAL ADOPTION, ANIMAL BEHAVIOR, ANIMAL CARE, ANIMAL CRUELTY, ANIMAL ENVIRONMENTS, ANIMAL PROTECTION, ANIMAL SHELTERS, ANIMAL WELFARE, ANIMAL VETERINARY SERVICES AND MEDICAL CARE, AND HUMANE ETHICS; PROVIDING A WEB SITE THAT FEATURES INFORMAL INSTRUCTION FOR CHILDREN AND EDUCATIONAL ACTIVITIES FOR CHILDREN REGARDING ANIMALS, ANIMAL ADOPTION, ANIMAL BEHAVIOR, ANIMAL CARE, ANIMAL CRUELTY, ANIMAL ENVIRONMENTS, ANIMAL PROTECTION, ANIMAL SHELTERS, ANIMAL WELFARE, ANIMAL VETERINARY SERVICES AND MEDICAL CARE, AND HUMANE ETHICS; ENTERTAINMENT SERVICES, NAMELY, PROVIDING ON-LINE, EDUCATIONAL COMPUTER GAMES AND CARTOONS FOR CHILDREN IN THE FIELDS OF ANIMALS, ANIMAL ADOPTION, ANIMAL BEHAVIOR, ANIMAL CARE, ANIMAL CRUELTY, ANIMAL ENVIRONMENTS, ANIMAL PROTECTION, ANIMAL SHELTERS, ANIMAL WELFARE, ANIMAL VETERINARY SERVICES AND MEDICAL CARE, AND HUMANE ETHICS (U.S. CLS. 100, 101 AND 107).

FIRST USE 4-1-2010; IN COMMERCE 4-1-2010.

CLASS 3—COSMETICS AND CLEANING PREPARATIONS

FOR SHAMPOOS AND CONDITIONERS FOR PETS (U.S. CLS. 1, 4, 6, 50, 51 AND 52).

CLASS 6—METAL GOODS

FOR PET IDENTIFICATION BANDS OF COMMON METAL; CUSTOM ENGRAVED IDENTIFICATION TAGS OF COMMON METAL (U.S. CLS. 2, 12, 13, 14, 23, 25 AND 50).

CLASS 9—ELECTRICAL AND SCIENTIFIC APPARATUS

FOR DOWNLOADABLE CHILDREN'S BOOKS; LCD PICTURE FRAMES AND DIGITAL PHOTO FRAMES; DOWNLOADABLE COMPUTER GAME PROGRAMS AND INTERACTIVE COMPUTER GAME PROGRAMS; COMPACT DISCS FEATURING MUSIC, GAMES, AND EDUCATIONAL CONTENT IN THE FIELDS OF ANIMALS, ANIMAL ADOPTION, ANIMAL BEHAVIOR, ANIMAL CARE, ANIMAL CRUELTY, ANIMAL ENVIRONMENTS, ANIMAL PROTECTION, ANIMAL SHELTERS, ANIMAL WELFARE, ANIMAL VETERINARY SERVICES AND MEDICAL CARE, AND HUMANE ETHICS; DOWNLOADABLE PUBLICATIONS IN THE NATURE OF NEWSLETTERS, ARTICLES AND MONOGRAPHS FOR CHILDREN IN THE FIELDS OF ANIMALS, ANIMAL ADOPTION, ANIMAL BEHAVIOR, ANIMAL CARE, ANIMAL CRUELTY, ANIMAL ENVIRONMENTS, ANIMAL PROTECTION, ANIMAL SHELTERS, ANIMAL WELFARE, ANIMAL VETERINARY SERVICES AND MEDICAL CARE, VOLUNTEERING AND SERVICE WITH AND FOR ANIMALS, AND HUMANE ETHICS (U.S. CLS. 21, 23, 26, 36 AND 38).

CLASS 14—JEWELRY

FOR JEWELRY; PET JEWELRY (U.S. CLS. 2, 27, 28 AND 50).

CLASS 44—MEDICAL, BEAUTY AND AGRICULTURAL SERVICES

FOR PROVIDING A WEB SITE FEATURING INFORMATION FOR CHILDREN IN THE FIELDS OF ANIMAL SELECTION, ANIMAL GROOMING, ANIMAL HEALTH, ANIMAL NUTRITION, ANIMAL BEHAVIOR, ANIMAL MEDICAL CARE, ANIMAL VETERINARY SERVICES AND HUMANE VETERINARY ETHICS (U.S. CLS. 100 AND 101).

FIRST USE 4-1-2010; IN COMMERCE 4-1-2010.
BRENDAN REGAN, EXAMINING ATTORNEY

CLASS 18—LEATHER GOODS

FOR LUGGAGE; TOTE BAGS; PURSES; BACK PACKS; PET COLLAR ACCESSORIES, NAMELY, BOWS, CHARMS, BELLS, SAFETY LIGHTS, PENDANTS AND BLINKERS; PET COLLARS AND ANIMAL LEASHES; PET APPAREL; ANIMAL CARRIER BAGS MADE OUT OF NYLON, CANVAS, POLYESTER, COTTON AND VINYL; UMBRELLAS (U.S. CLS. 1, 2, 3, 22 AND 41).

CLASS 20—FURNITURE AND ARTICLES NOT OTHERWISE CLASSIFIED

FOR PET IDENTIFICATION BANDS OF PLASTIC, RUBBER, NYLON, COTTON, CANVAS AND VINYL; NON-METAL PET GATES; HOUSEHOLD PET BEDS; PET PILLOWS AND PILLOWS; WOODEN PRESSURE MOUNT PET GATES; NON-METAL IDENTIFICATION BRACELETS; LARGE OUTDOOR KENNELS; PLASTIC PORTABLE KENNELS; CRATE COVERS FOR PETS; PICTURE FRAMES (U.S. CLS. 2, 13, 22, 25, 32 AND 50).

CLASS 21—HOUSEWARES AND GLASS

FOR BATH AND GROOMING PRODUCTS FOR PETS, NAMELY, SPONGES, COMBS, AND BRUSHES; PET BRUSHES AND COMBS; PET FEEDING VESSELS; METAL AND NON-METAL PET FEEDING AND DRINKING BOWLS; CAGES FOR PETS; MUGS (U.S. CLS. 2, 13, 23, 29, 30, 33, 40 AND 50).

CLASS 24—FABRICS

FOR THROWS; BED THROWS; PILLOW COVERS AND CASES; TOWELS; HANDKERCHIEFS (U.S. CLS. 42 AND 50).

CLASS 25—CLOTHING

FOR MEDICAL SCRUBS NOT FOR MEDICAL USE; APPAREL FOR ADULTS, TEENS AND CHILDREN, NAMELY, T-SHIRTS, SHIRTS, BLOUSES, SWEAT SHIRTS, SCARVES, BANDANAS, TIES, JACKETS, COATS, SOCKS, UNDERGARMENTS, PANTS, SHORTS, SKIRTS, DRESSES, LEGGINGS, PAJAMAS, GLOVES, HATS, CAPS, BELTS, FOOTWEAR, JUMPERS, OVERALL SLEEPWEAR, ROMPERS AND ONE-PIECE GARMENTS FOR CHILDREN (U.S. CLS. 22 AND 39).

CLASS 26—FANCY GOODS

FOR BELT BUCKLES; LACES FOR FOOTWEAR (U.S. CLS. 37, 39, 40, 42 AND 50).

CLASS 28—TOYS AND SPORTING GOODS

FOR PET TOYS; TOYS AND GAMES, NAMELY, PLUSH DOLLS, MODELED PLASTIC TOY FIGURINES, ACTION FIGURES, BOARD GAMES, CARD GAMES, PUZZLES, AND INFLATABLE TOYS; HOBBY CRAFT KITS FOR DECORATING PET COLLARS, PET LEASHES, PET FOOD AND WATER BOWLS, TOTES, LUGGAGE, BACK PACKS, PET CARRIES AND PET KENNELS COMPRISING FABRIC, PAINT AND OTHER DECORATIVE MATERIALS (U.S. CLS. 22, 23, 38 AND 50).

CLASS 31—NATURAL AGRICULTURAL PRODUCTS

FOR PET FOODS; ORGANIC GARDENING KITS FOR INDOOR AND OUTDOOR PLANTING COMPOSED PRIMARILY OF ORGANIC AGRICULTURAL SEEDS, SEEDS FOR FRUITS AND VEGETABLES, SEEDS FOR FLOWERS, SEEDS FOR GRASSES, SEEDS FOR HERBS AND ALSO INCLUDING SOIL, PLANTING VESSELS, AND INSTRUCTIONS, SOLD AS A UNIT (U.S. CLS. 1 AND 46).

BRENDAN REGAN, EXAMINING ATTORNEY

SN 85-158,716. LAPORTE HOLDING, BIOT, FRANCE, FILED 10-22-2010.



PRIORITY CLAIMED UNDER SEC. 44(D) ON ERPN CMNTY TM OFC APPLICATION NO. 009456633, FILED 10-19-2010, REG. NO. 009456633, DATED 4-1-2011, EXPIRES 10-19-2020.

OWNER OF U.S. REG. NOS. 1,364,663 AND 1,706,940.

NO CLAIM IS MADE TO THE EXCLUSIVE RIGHT TO USE "ARCHERY" AND "SINCE 1927", APART FROM THE MARK AS SHOWN.

THE COLOR(S) RED, WHITE, BLACK AND GRAY IS/ARE CLAIMED AS A FEATURE OF THE MARK.

THE MARK CONSISTS OF WINGS IN BLACK AND SHADES OF GRAY; THE WORD "LAPORTE" IN RED AND OUTLINED IN WHITE AND BLACK, SUPERIMPOSED OVER THE WINGS; A RED ARCHER SILHOUETTE AND A BLACK AND WHITE TARGET INSIDE THE "O" IN "LAPORTE"; THE WORDING "ARCHERY" IN BLACK BELOW THE "O" IN "LAPORTE"; AND THE WORDING "SINCE 1927" IN BLACK BELOW THE LETTERS "R" AND "T" IN "LAPORTE".

CLASS 28—TOYS AND SPORTING GOODS

FOR APPARATUS FOR LAUNCHING TARGETS, NAMELY, TARGET LAUNCHERS FOR PLASTIC AND NON-PLASTIC ARCHERY TARGETS; PLASTIC ARCHERY TARGETS; ARCHERY IMPLEMENTS, NAMELY, ARM GUARDS, ARROW FLETCHING DEVICES, BOWS, BOW BAGS, BOW CASES, BOW STRING CHANGERS, BOW STRINGS, NON-TELESCOPIC BOW SIGHTS, OPEN BOW SIGHTS, BROAD HEADS, FINGER TABS, ARROW POINTS, STRINGERS AND QUIVERS (U.S. CLS. 22, 23, 38 AND 50).

CLASS 41—EDUCATION AND ENTERTAINMENT

FOR EDUCATION SERVICES, NAMELY, CLASSES AND SEMINARS IN THE FIELD OF ARCHERY; PRACTICAL TRAINING IN THE FIELD OF ARCHERY; ORGANIZING SPORTING AND CULTURAL ACTIVITIES; ENTERTAINMENT, NAMELY, TOURNAMENTS AND EXHIBITIONS IN THE FIELD OF ARCHERY; PROVIDING ENTERTAINMENT AND EDUCATION INFORMATION IN THE FIELD OF ARCHERY; PROVIDING RECREATION FACILITIES; PUBLICATION OF BOOKS; ORGANIZATION OF ENTERTAINMENT AND EDUCATION COMPETITIONS IN THE NATURE OF ARCHERY; ARRANGING AND CONDUCTING OF COLLOQUIUMS, CONFERENCES OR CONGRESSES IN THE FIELD OF ARCHERY; ORGANIZATION OF EXHIBITIONS FOR CULTURAL OR EDUCATIONAL PURPOSES; GAMES SERVICES PROVIDED ONLINE FROM A COMPUTER NETWORK, NAMELY, PROVIDING ONLINE VIDEO GAMES; PUBLICATION OF ELECTRONIC BOOKS AND JOURNALS ONLINE; RENTAL OF SPORTS EQUIPMENT EXCEPT VEHICLES; OPERATION OF SPORT CAMPS; ORGANIZATION OF SPORTS COMPETITIONS; PROVIDING OF SPORTS FACILITIES; TIMING OF SPORTS EVENTS; RENTAL OF STADIUM FACILITIES (U.S. CLS. 100, 101 AND 107).

JULIE GUTTADAURO, EXAMINING ATTORNEY

SN 85-159,392. TRAINING FOR WARRIORS LLC, FAIR-LAWN, NJ. FILED 10-22-2010.



NO CLAIM IS MADE TO THE EXCLUSIVE RIGHT TO USE "TRAINING", APART FROM THE MARK AS SHOWN. THE MARK CONSISTS OF THE WORDING "TFW" APPEARING ABOVE THE WORDING "TRAINING FOR WARRIORS". TO THE LEFT OF THE WORDING APPEARS A DESIGN OF THE ROMAN COLISEUM INSIDE A TRIANGLE WITH CURVED SIDES.

CLASS 9—ELECTRICAL AND SCIENTIFIC APPARATUS

FOR DIGITAL MEDIA, NAMELY, PRE-RECORDED VIDEO CASSETTES, DIGITAL VIDEO DISCS, DIGITAL VERSATILE DISCS, DOWNLOADABLE AUDIO AND VIDEO RECORDINGS, DVDS, AND HIGH DEFINITION DIGITAL DISCS FEATURING PHYSICAL FITNESS TRAINING (U.S. CLS. 21, 23, 26, 36 AND 38).

FIRST USE 10-1-2005; IN COMMERCE 10-1-2005.

CLASS 16—PAPER GOODS AND PRINTED MATTER

FOR A SERIES OF BOOKS AND WRITTEN ARTICLES IN THE FIELD OF PHYSICAL FITNESS TRAINING (U.S. CLS. 2, 5, 22, 23, 29, 37, 38 AND 50).

FIRST USE 8-31-2004; IN COMMERCE 8-31-2004.

CLASS 41—EDUCATION AND ENTERTAINMENT

FOR PERSONAL FITNESS TRAINING SERVICES AND CONSULTANCY; PHYSICAL FITNESS INSTRUCTION (U.S. CLS. 100, 101 AND 107).

FIRST USE 11-30-2005; IN COMMERCE 11-30-2005.

KATHERINE E. HALMEN, EXAMINING ATTORNEY

SN 85-160,094. PATIRE, TOM, WOODCLIFF LAKE, NJ. FILED 10-25-2010.

NURSE-SAFE

THE MARK CONSISTS OF STANDARD CHARACTERS WITHOUT CLAIM TO ANY PARTICULAR FONT, STYLE, SIZE, OR COLOR.

CLASS 25—CLOTHING

FOR CLOTHING, NAMELY, SHIRTS, GOLF SHIRTS, COLLARED SHIRTS, T-SHIRTS, SWEAT SHIRTS, TURTLENECK SWEATERS, MOCK TURTLENECK SWEATERS, SWEATERS, FOOTWEAR, BOOTS, HEADWEAR, HATS AND CAPS (U.S. CLS. 22 AND 39).

FIRST USE 2-12-2008; IN COMMERCE 2-12-2008.

CLASS 41—EDUCATION AND ENTERTAINMENT

FOR EDUCATIONAL SERVICES, NAMELY, PROVIDING INSTRUCTION, AND DEVELOPING AND CONDUCTING WORKSHOPS, PRESENTATIONS AND SEMINARS IN THE FIELD OF PERSONAL SAFETY FOR HEALTH CARE INDUSTRY PROFESSIONALS (U.S. CLS. 100, 101 AND 107).

FIRST USE 2-12-2008; IN COMMERCE 2-12-2008.

CORY BOONE, EXAMINING ATTORNEY

SN 85-164,188. GANIMEDES LTD., NICOSIA, CYPRUS, FILED 10-28-2010.

MCHAT

THE MARK CONSISTS OF STANDARD CHARACTERS WITHOUT CLAIM TO ANY PARTICULAR FONT, STYLE, SIZE, OR COLOR.

PRIORITY CLAIMED UNDER SEC. 44(D) ON ERPNCMNTY TM OFC APPLICATION NO. 009309212, FILED 8-11-2010, REG. NO. 009309212, DATED 8-30-2011, EXPIRES 8-30-2021.

THE WORDING "MCHAT" HAS NO MEANING IN A FOREIGN LANGUAGE.

CLASS 9—ELECTRICAL AND SCIENTIFIC APPARATUS

FOR COMPUTER SOFTWARE FEATURING DIGITAL MUSIC, AUDIO, VIDEO, TEXT, AND DATA INFORMATION DOWNLOADABLE FROM THE INTERNET AND OTHER REMOTE COMMUNICATIONS NETWORKS USED WITH PERSONAL DIGITAL ASSISTANTS, SMART PHONES AND PORTABLE TABLET COMPUTERS; DOWNLOADABLE DATA FILES FROM THE INTERNET AND OTHER REMOTE COMMUNICATIONS NETWORKS; INTER-ACTIVE SOCIAL NETWORKING SOFTWARE FOR USE ON PERSONAL DIGITAL ASSISTANTS, SMART PHONES AND PORTABLE TABLET COMPUTERS; ELECTRONIC COMMUNICATIONS DEVICES, NAMELY, PERSONAL DIGITAL ASSISTANTS, SMART PHONES AND PORTABLE TABLET COMPUTERS; ELECTRONIC WIRELESS DEVICES, NAMELY, PERSONAL DIGITAL ASSISTANTS, SMART PHONES AND PORTABLE TABLET COMPUTERS, FOR RECORDING, ORGANIZING, TRANSMITTING, MANIPULATING, AND REVIEWING TEXT, DATA, AND AUDIO FILES (U.S. CLS. 21, 23, 26, 36 AND 38).

CLASS 35—ADVERTISING AND BUSINESS

FOR PROVIDING ADVERTISING AVAILABLE ONLINE, ON COMPUTER DATABASES, THE INTERNET AND COMMUNICATIONS NETWORKS; PROMOTION OF GOODS AND SERVICES VIA AN ON-LINE SERVICE WITH LINKS TO THE WEBSITES AND ONLINE SERVICES OF OTHERS; ON-LINE RETAIL STORE SERVICES FEATURING PORTABLE APPLICATIONS COMPUTER SOFTWARE, COMPUTER GAMES AND ENTERTAINMENT SOFTWARE FOR PERSONAL DIGITAL ASSISTANTS, SMART PHONES AND PORTABLE TABLET COMPUTERS (U.S. CLS. 100, 101 AND 102).

CLASS 38—COMMUNICATION

FOR TELECOMMUNICATIONS, NAMELY, PROVIDING MULTIPLE-USER ACCESS TO THE INTERNET AND RADIO BROADCASTING SERVICES; PROVIDING ACCESS TO A WORLD WIDE COMPUTER FOR DOWNLOADING COMPUTER SOFTWARE AND INFORMATION IN THE NATURE OF ADVERTISING, NEWS AND MULTIMEDIA CONTENT; TRANSMISSION OF SOUND, VIDEO AND INFORMATION FROM WEB CAMS, VIDEO CAMERAS OR MOBILE PHONES, ALL FEATURING LIVE OR RECORDED MATERIALS; PROVIDING VOICE OVER IP SERVICES, AND PEER-TO-PEER COMMUNICATIONS, NAMELY, ELECTRONIC TRANSMISSION OF DATA AND DOCUMENTS OVER COMPUTER TERMINALS; PROVIDING A HIGH SPEED ACCESS TO AREA NETWORKS AND A GLOBAL COMPUTER INFORMATION NETWORK; PROVIDING MULTIPLE-USER ACCESS TO THE INTERNET AND GLOBAL COMPUTER NETWORKS; PROVIDING CHAT ROOM SERVICES AND ONLINE FORUMS FOR SOCIAL NETWORKING; PROVIDING CHAT ROOMS AND INTERACTIVE FORUMS FOR SOCIAL INTERACTION (U.S. CLS. 100, 101 AND 104).

CLASS 45—PERSONAL AND LEGAL SERVICES

FOR PROVIDING EXECUTIVE PROTECTION SERVICES, MONITORING BURGLARY AND SECURITY ALARMS; PROVIDING A SOCIAL NETWORKING WEB SITE FOR ENTERTAINMENT SERVICES (U.S. CLS. 100 AND 101).

DAVID C. REIHNER, EXAMINING ATTORNEY

SN 85-170,172. TYCO FIRE PRODUCTS, LP, LANSDALE, PA. FILED 11-5-2010.

G-FIRE

THE MARK CONSISTS OF STANDARD CHARACTERS WITHOUT CLAIM TO ANY PARTICULAR FONT, STYLE, SIZE, OR COLOR.

CLASS 6—METAL GOODS

FOR METAL PIPES AND METAL FITTINGS THEREFOR; METAL PIPE SUPPORTS; METAL COUPLINGS, NAMELY, COUPLINGS FOR FIRE HOSES, GROOVED COUPLINGS, HIGH-PRESSURE COUPLINGS, REDUCING COUPLINGS, FLEXIBLE COUPLINGS, RIGID COUPLINGS, PLAIN END COUPLINGS, TRANSITION COUPLINGS, FLANGE COUPLINGS, MECHANICAL OUTLET COUPLINGS ALL FOR USE WITH HYDRAULIC AND PNEUMATIC SYSTEMS; METAL COUPLING NUTS AND BOLTS; METAL PIPE COLLARS; METAL DRILL COLLARS; METAL GROOVED FLANGE ADAPTERS; METAL VALVES NOT BEING PARTS OF MACHINES, NAMELY, BUTTERFLY VALVES, GROOVED CHECK VALVES, BALL VALVES, FLOW CONTROL VALVES, CIRCUIT BALANCING VALVES; METAL FASTENERS, NAMELY, NUTS, BOLTS, SCREWS, ANCHORS, WASHERS, THREADED ROD CONNECTORS, SUPPORT BRACKETS, CLIPS, CLAMPS AND BANDS, ALL OF THE FOREGOING MADE OF METAL AND ALL FOR INDUSTRIAL USE (U.S. CLS. 2, 12, 13, 14, 23, 25 AND 50).

CLASS 9—ELECTRICAL AND SCIENTIFIC APPARATUS

FOR AUTOMATIC VALVES AND ELECTRIC ACTUATORS THEREFOR; ELECTRIC VALVE ACTUATORS FOR USE WITH AUTOMATIC VALVES (U.S. CLS. 21, 23, 26, 36 AND 38).

CLASS 17—RUBBER GOODS

FOR NON-METAL FLEXIBLE PIPES AND FITTINGS THEREFOR, ALL FOR USE WITH, OR BEING PARTS OF, FIRE-EXTINGUISHING SYSTEMS; NON-METAL COUPLINGS, NAMELY, COUPLINGS FOR FIRE HOSES, GROOVED COUPLINGS, HIGH-PRESSURE COUPLINGS, REDUCING COUPLINGS, FLEXIBLE COUPLINGS, RIGID COUPLINGS, PLAIN END COUPLINGS, TRANSITION COUPLINGS, FLANGE COUPLINGS, MECHANICAL OUTLET COUPLINGS ALL FOR USE WITH HYDRAULIC AND PNEUMATIC SYSTEMS; NON-METAL WASHERS OF RUBBER OR VULCANIZED FIBER; VALVES OF RUBBER OR VULCANIZED FIBER, NOT INCLUDING MACHINE ELEMENTS, NAMELY, BUTTERFLY VALVES, GROOVED CHECK VALVES, BALL VALVES, FLOW CONTROL VALVES, CIRCUIT BALANCING VALVES; NON-METAL PIPE STANDS, NAMELY, INSULATED PIPE SUPPORTS; NON-METAL GROOVED FLANGE ADAPTERS; NON-METAL PIPE CAPS; PIPE GASKETS; RINGS OF RUBBER FOR USE AS PIPE CONNECTION SEALS; NON-METAL FASTENERS, NAMELY, WASHERS MADE OF RUBBER OR VULCANIZED FIBER; NON-METAL THREADED ROD CONNECTORS; RUBBER BANDS FOR INDUSTRIAL USE (U.S. CLS. 1, 5, 12, 13, 35 AND 50).

KRISTIN CARLSON, EXAMINING ATTORNEY

SN 85-172,232. WILLOWSFORD, L.L.C., DALLAS, TX. FILED 11-9-2010.

WILLOWSFORD CONSERVANCY

THE MARK CONSISTS OF STANDARD CHARACTERS WITHOUT CLAIM TO ANY PARTICULAR FONT, STYLE, SIZE, OR COLOR.

NO CLAIM IS MADE TO THE EXCLUSIVE RIGHT TO USE "CONSERVANCY", APART FROM THE MARK AS SHOWN.

CLASS 16—PAPER GOODS AND PRINTED MATTER

FOR PUBLICATIONS, NAMELY, BOOKS, MAGAZINES, BROCHURES, AND FLYERS FEATURING INFORMATION ON THE ENVIRONMENT, COMMUNITY-SUPPORTED AGRICULTURE, FARMING, PHILANTHROPY, EDUCATION, NATURE, STEWARDSHIP, RESIDENTIAL COMMUNITY LIFESTYLE, AND THE CONSERVATION OF LAND, WILDLIFE AND NATURAL RESOURCES (U.S. CLS. 2, 5, 22, 23, 29, 37, 38 AND 50).

CLASS 35—ADVERTISING AND BUSINESS

FOR MANAGEMENT OF A LAND CONSERVANCY TO PRESERVE LAND, WILDLIFE AND NATURAL RESOURCES; PROVIDING FARMERS' MARKETS; CHARITABLE SERVICES, NAMELY, ORGANIZING AND DEVELOPING PROJECTS TO PROMOTE PUBLIC AWARENESS OF AGRICULTURE AND THE CONSERVATION OF LAND, WILDLIFE AND NATURAL RESOURCES (U.S. CLS. 100, 101 AND 102).

CLASS 36—INSURANCE AND FINANCIAL

FOR LEASING OF REAL ESTATE TO OTHERS FOR THE PURPOSE OF CULTIVATING THE LAND (U.S. CLS. 100, 101 AND 102).

CLASS 41—EDUCATION AND ENTERTAINMENT

FOR RECREATIONAL ACTIVITIES, NAMELY, PROVIDING A SYSTEM OF COMMUNITY AND NEIGHBORHOOD PARKS; PROVIDING FACILITIES FOR COMMUNITY SOCIALIZATION ACTIVITIES AND CULTURAL ACTIVITIES; ORGANIZATION OF VOLUNTEER ACTIVITIES, NAMELY, PROVIDING A VOLUNTEER PROGRAM FEATURING RECREATIONAL ACTIVITIES, ART EVENTS AND SPORTS EVENTS FOR RESIDENTS AND ORGANIZING COMMUNITY FESTIVALS; PROVIDING EDUCATIONAL SERVICES, NAMELY, CLASSES AND WORKSHOPS IN THE FIELD OF AGRICULTURE, GARDENING, AND THE MANAGEMENT AND CONSERVATION OF LAND, WILDLIFE AND NATURAL RESOURCES (U.S. CLS. 100, 101 AND 107).

DAWN FELDMAN, EXAMINING ATTORNEY

CLASS 38—COMMUNICATION

FOR TELECOMMUNICATIONS SERVICES, NAMELY, TRANSMISSION OF VOICE, DATA, GRAPHICS, IMAGES, AUDIO AND VIDEO BY MEANS OF TELECOMMUNICATIONS NETWORKS, WIRELESS COMMUNICATION NETWORKS, AND THE INTERNET; PROVIDING TELECOMMUNICATIONS-RELATED INFORMATION VIA THE INTERNET; COMMUNICATION VIA COMPUTER TERMINALS OR VIA OPTICAL FIBER NETWORKS; RADIO OR TELEPHONE COMMUNICATION; PORTABLE RADIO TELEPHONE SERVICES; PROVISION OF ACCESS TO A WORLD-WIDE IT NETWORK; ELECTRONIC DISPLAY SERVICES, NAMELY, ELECTRONIC TRANSMISSION OF MESSAGES, DATA AND DIGITAL FILES; PROVIDING TELECOMMUNICATION CONNECTION TO A WORLD-WIDE IT NETWORK; RENTAL OF TELECOMMUNICATIONS EQUIPMENT; RADIO OR TELEVISION PROGRAMS; TELECONFERENCE SERVICES; E-MAIL SERVICES (U.S. CLS. 100, 101 AND 104).

SN 85-172,320. BELLECORE, LLC, LOWELL, MA. FILED 11-9-2010.

BUFF OFF!

THE MARK CONSISTS OF STANDARD CHARACTERS WITHOUT CLAIM TO ANY PARTICULAR FONT, STYLE, SIZE, OR COLOR.

NO CLAIM IS MADE TO THE EXCLUSIVE RIGHT TO USE "BUFF" FOR INTERNATIONAL CLASS 10, APART FROM THE MARK AS SHOWN.

CLASS 10—MEDICAL APPARATUS

FOR MESSAGE APPARATUS, MOISTURIZING CREAM, INSTRUCTIONAL SOFTWARE AND MANUAL, AND MESSAGE KIT CARRYING CASE, ALL SOLD AS A UNIT (U.S. CLS. 26, 39 AND 44).

CLASS 25—CLOTHING

FOR CLOTHING, NAMELY, T-SHIRTS (U.S. CLS. 22 AND 39).

JULIE GUTTADAURO, EXAMINING ATTORNEY

SN 85-178,376. BULL S.A.S., F-78340 LES CLAYES SOU BOIS, FRANCE, FILED 11-16-2010.

EXTREME FACTORY

THE MARK CONSISTS OF STANDARD CHARACTERS WITHOUT CLAIM TO ANY PARTICULAR FONT, STYLE, SIZE, OR COLOR.

PRIORITY CLAIMED UNDER SEC. 44(D) ON FRANCE APPLICATION NO. 10/3774659, FILED 10-15-2010, REG. NO. 10/3774659, DATED 10-15-2010, EXPIRES 10-15-2020.

CLASS 42—SCIENTIFIC AND COMPUTER SERVICES

FOR SCIENTIFIC RESEARCH, CARRIED OUT BY ENGINEERS, IN THE FIELDS OF CLOUD COMPUTING, COMPUTER SIMULATION, COMPUTER HARDWARE, AND COMPUTER SOFTWARE; DESIGN AND DEVELOPMENT OF COMPUTERS AND SOFTWARE; CONSULTING SERVICES IN THE FIELDS OF COMPUTER HARDWARE AND SOFTWARE, CLOUD COMPUTING, COMPUTER SIMULATION, SOFTWARE AS A SERVICE (SAAS), AND HIGH PERFORMANCE COMPUTING; INTEGRATION SERVICES, NAMELY, COMPUTER SYSTEMS INTEGRATION SERVICES AND IT INTEGRATION SERVICES; INFORMATION TECHNOLOGY CONSULTATION IN THE FIELD OF OUTSOURCING TECHNOLOGY; PROVIDING VIRTUAL COMPUTER SYSTEMS AND VIRTUAL COMPUTER ENVIRONMENTS THROUGH CLOUD COMPUTING; CONCEPTION AND DEVELOPMENT OF IT SYSTEMS FOR THIRD PARTY APPLICATIONS; CONCEPTION AND DEVELOPMENT OF THIRD PARTY APPLICATIONS ON SHARED, DISTRIBUTED PLATFORMS; PROVIDING OF APPLICATIONS AND HOSTING OF APPLICATIONS ON SHARED PLATFORMS; RESEARCH AND DEVELOPMENT OF NEW PRODUCTS FOR THIRD PARTIES; TECHNICAL PROJECT STUDIES IN THE FIELDS OF INFORMATION TECHNOLOGY AND HIGH PERFORMANCE COMPUTING; ARCHITECTURE DESIGN SERVICES, CONSULTING IN THE FIELD OF ARCHITECTURE DESIGN, TECHNICAL CONSULTING SERVICES IN THE FIELD OF DATACENTER ARCHITECTURE; INSTALLATION, MAINTENANCE, UPDATING OR RENTAL OF SOFTWARE; COMPUTER PROGRAMMING; DATA AND IT PROGRAM CONVERSION OTHER THAN PHYSICAL CONVERSION; DOCUMENT CONVERSION FROM A PHYSICAL MEDIUM TO AN ELECTRONIC MEDIUM; ENGINEERING SERVICES (U.S. CLS. 100 AND 101).

FLORENTINA BLANDU, EXAMINING ATTORNEY

SN 85-183,177. AVATAR PROPERTIES INC., CORAL GABLES, FL. FILED 11-23-2010.



OWNER OF U.S. REG. NO. 2,377,808.
THE MARK CONSISTS OF STYLIZED "V" INCLUDING A CIRCLE LOCATED ABOVE AND IN THE MIDDLE OF THE EXTENDED ARMS OF THE LETTER.

CLASS 18—LEATHER GOODS

FOR GENERAL PURPOSE TOTE BAGS FOR TENNIS AND GOLF (U.S. CLS. 1, 2, 3, 22 AND 41).

CLASS 24—FABRICS

FOR TEXTILE FLAGS FOR GOLF CARTS (U.S. CLS. 42 AND 50).

CLASS 28—TOYS AND SPORTING GOODS

FOR GOLF BALLS, TENNIS BALLS, TOTE BAGS SPECIFICALLY ADAPTED FOR GOLF AND TENNIS EQUIPMENT (U.S. CLS. 22, 23, 38 AND 50).
ANDREW LEASER, EXAMINING ATTORNEY

SN 85-185,820. YING KEE TEA HOUSE (TRADEMARKS) LIMITED, SIU SAI WAN, HONG KONG, HONG KONG, FILED 11-28-2010.

英記茶莊
YING KEE TEA HOUSE

NO CLAIM IS MADE TO THE EXCLUSIVE RIGHT TO USE "TEA HOUSE" OR "THE NON-LATIN CHARACTERS THAT TRANSLITERATE TO CHA CHONG", APART FROM THE MARK AS SHOWN.

THE MARK CONSISTS OF CHINESE CHARACTERS ABOVE WORDING "YING KEE TEA HOUSE".

THE ENGLISH TRANSLATION OF "YING KEE" IN THE MARK IS YING'S, WHERE YING MEANS "A HERO", OR A PERSON'S FIRST NAME OR A SURNAME, AND "KEE" IS AN INDICATOR OF A POSSESSIVE NOUN, WHICH IS SHOWN IN ENGLISH AS 'S.

THE NON-LATIN CHARACTERS IN THE MARK TRANSLITERATE TO "YING KEE CHA CHONG" AND THIS MEANS "YING'S TEA HOUSE" IN ENGLISH.

CLASS 30—STAPLE FOODS

FOR TEA; ICED TEA; TEA-BASED BEVERAGES; TEA BAGS; NON-MEDICATED TEA BAGS; PACKAGED TEA OTHER THAN FOR MEDICINAL USE (U.S. CL. 46).

CLASS 35—ADVERTISING AND BUSINESS

FOR RETAIL AND WHOLESALING SERVICES, NAMELY, RETAIL STORE SERVICES, WHOLESALE DISTRIBUTORSHIP SERVICES FEATURING TEA AND TEA BEVERAGES; SALES PROMOTION SERVICES FOR TEA; PRESENTATION OF GOODS ON COMMUNICATION MEDIA, FOR RETAIL PURPOSES (U.S. CLS. 100, 101 AND 102).

RICHARD WHITE, EXAMINING ATTORNEY

SN 85-187,572. ZYNGA INC., SAN FRANCISCO, CA. FILED 11-30-2010.

CITYVILLE

THE MARK CONSISTS OF STANDARD CHARACTERS WITHOUT CLAIM TO ANY PARTICULAR FONT, STYLE, SIZE, OR COLOR.

PRIORITY CLAIMED UNDER SEC. 44(D) ON TRINIDAD/TOBAGO APPLICATION NO. 42723, FILED 9-14-2010.
OWNER OF U.S. REG. NO. 3,994,661.

CLASS 9—ELECTRICAL AND SCIENTIFIC APPARATUS

FOR COMPUTER GAME SOFTWARE; COMPUTER GAME PROGRAMS; ELECTRONIC GAME PROGRAMS; INTERACTIVE VIDEO GAME PROGRAMS; COMPUTER SOFTWARE PLATFORMS FOR SOCIAL NETWORKING, NAMELY, COMPUTER SOFTWARE TO ENABLE UPLOADING, POSTING, SHOWING, DISPLAYING, TAGGING, BLOGGING, SHARING OR OTHERWISE PROVIDING ELECTRONIC MEDIA OR INFORMATION IN THE FIELDS OF VIRTUAL COMMUNITIES, ELECTRONIC GAMING, ENTERTAINMENT, AND GENERAL INTEREST VIA THE INTERNET OR OTHER COMMUNICATIONS NETWORKS WITH THIRD PARTIES; MAGNETIC ENCODED GIFT CARDS (U.S. CLS. 21, 23, 26, 36 AND 38).

CLASS 41—EDUCATION AND ENTERTAINMENT

FOR ENTERTAINMENT SERVICES, NAMELY, PROVIDING ONLINE COMPUTER AND ELECTRONIC GAMES AND PROVIDING ENHANCEMENTS WITHIN ONLINE COMPUTER AND ELECTRONIC GAMES; ENTERTAINMENT SERVICES, NAMELY, PROVIDING ONLINE INFORMATION RELATING TO COMPUTER GAMES; ENTERTAINMENT SERVICES, NAMELY, PROVIDING VIRTUAL ENVIRONMENTS IN WHICH USERS CAN INTERACT THROUGH SOCIAL GAMES FOR RECREATIONAL, LEISURE OR ENTERTAINMENT PURPOSES (U.S. CLS. 100, 101 AND 107).

KATHERINE CHANG, EXAMINING ATTORNEY

SN 85-188,948. THE ORIGINAL BROOKLYN WATER BAGEL CO., INC., DELRAY BEACH, FL. FILED 12-2-2010.

**THE ORIGINAL BROOKLYN
WATER PIZZA & PASTA CO.**

THE MARK CONSISTS OF STANDARD CHARACTERS WITHOUT CLAIM TO ANY PARTICULAR FONT, STYLE, SIZE, OR COLOR.

OWNER OF U.S. REG. NO. 4,014,959.

NO CLAIM IS MADE TO THE EXCLUSIVE RIGHT TO USE "PIZZA & PASTA CO.", APART FROM THE MARK AS SHOWN.

SEC. 2(F).

CLASS 30—STAPLE FOODS

FOR PASTA; PIZZA; AND PIZZA DOUGH (U.S. CL. 46).

CLASS 43—HOTEL AND RESTAURANT SERVICES

FOR RESTAURANT SERVICES (U.S. CLS. 100 AND 101).

AMEEN IMAM, EXAMINING ATTORNEY

SN 85-195,831. ORRIGO, JAMES, MEDFORD, MA. FILED 12-11-2010.



THE MARK CONSISTS OF THE STYLIZED WORDING "LAD IN A BATTLE" AND THE SILHOUETTE OF A STANDING PERSON HOLDING A GUITAR BY A GUITAR STRAP, WITH THE PERSON FACING AWAY AND LOOKING TO THE LEFT.

CLASS 9—ELECTRICAL AND SCIENTIFIC APPARATUS

FOR AUDIO AND VIDEO RECORDINGS FEATURING MUSIC, ARTISTIC PERFORMANCES AND SELF IMPROVEMENT INSTRUCTION; DIGITAL MUSIC DOWNLOADABLE FROM THE INTERNET (U.S. CLS. 21, 23, 26, 36 AND 38).

FIRST USE 8-4-2010; IN COMMERCE 8-4-2010.

CLASS 25—CLOTHING

FOR CLOTHING AND APPAREL, NAMELY, T-SHIRTS, HOODED SWEAT SHIRTS, SWEAT SHIRTS, HATS, LONG-SLEEVE SHIRTS, SHORT-SLEEVE SHIRTS, POLO SHIRTS, SWEAT PANTS, AND TANK-TOPS (U.S. CLS. 22 AND 39).

FIRST USE 8-4-2010; IN COMMERCE 8-4-2010.

HOWARD B. LEVINE, EXAMINING ATTORNEY

SN 85-197,298. QVC, INC., WEST CHESTER, PA. FILED 12-14-2010.

HOME REFLECTIONS

THE MARK CONSISTS OF STANDARD CHARACTERS WITHOUT CLAIM TO ANY PARTICULAR FONT, STYLE, SIZE, OR COLOR.

OWNER OF U.S. REG. NO. 3,782,224.

NO CLAIM IS MADE TO THE EXCLUSIVE RIGHT TO USE "HOME", APART FROM THE MARK AS SHOWN.

CLASS 11—ENVIRONMENTAL CONTROL APPARATUS

FOR ELECTRIC LAMPS (U.S. CLS. 13, 21, 23, 31 AND 34).

FIRST USE 3-30-2010; IN COMMERCE 3-30-2010.

CLASS 20—FURNITURE AND ARTICLES NOT OTHERWISE CLASSIFIED

FOR FURNITURE (U.S. CLS. 2, 13, 22, 25, 32 AND 50).
FIRST USE 1-21-2010; IN COMMERCE 1-21-2010.

CLASS 27—FLOOR COVERINGS

FOR RUGS (U.S. CLS. 19, 20, 37, 42 AND 50).

FIRST USE 8-4-2010; IN COMMERCE 8-4-2010.

SUZANNE BLANE, EXAMINING ATTORNEY

SN 85-214,635. BLUE HIGHWAY, LLC, DBA A WELCH ALLYN COMPANY, SYRACUSE, NY. FILED 1-11-2011.

U2MD

THE MARK CONSISTS OF STANDARD CHARACTERS WITHOUT CLAIM TO ANY PARTICULAR FONT, STYLE, SIZE, OR COLOR.

CLASS 9—ELECTRICAL AND SCIENTIFIC APPARATUS

FOR COMPUTER SOFTWARE FOR CONTROLLING AND MANAGING PATIENT MEDICAL INFORMATION; SOFTWARE IN THE FIELD OF PATIENT MONITORING AND INFORMATION MANAGEMENT SYSTEMS FOR FACILITATING TRANSFER OF PATIENT-RELATED INFORMATION (U.S. CLS. 21, 23, 26, 36 AND 38).

CLASS 10—MEDICAL APPARATUS

FOR PATIENT MONITORING SENSORS (U.S. CLS. 26, 39 AND 44).

CLASS 42—SCIENTIFIC AND COMPUTER SERVICES

FOR SOFTWARE AS A SERVICE (SAAS) SERVICES FEATURING SOFTWARE IN THE FIELD OF PATIENT MONITORING AND INFORMATION MANAGEMENT SYSTEMS FOR FACILITATING TRANSFER OF PATIENT-RELATED INFORMATION (U.S. CLS. 100 AND 101).

FIRST USE 10-21-2010; IN COMMERCE 10-21-2010.
AISHA SALEM, EXAMINING ATTORNEY

SN 85-218,467. FINANCIAL INDUSTRY REGULATORY AUTHORITY, INC., WASHINGTON, DC. FILED 1-14-2011.

OTC BULLETIN BOARD

THE MARK CONSISTS OF STANDARD CHARACTERS WITHOUT CLAIM TO ANY PARTICULAR FONT, STYLE, SIZE, OR COLOR.
SEC. 2(F).

CLASS 35—ADVERTISING AND BUSINESS

FOR ON-LINE RETAIL STORE SERVICES FEATURING MARKET AND TRADING DATA REPORTS, COMPANY DIRECTORIES AND COMPANY PROFILES (U.S. CLS. 100, 101 AND 102).

FIRST USE 1-14-2000; IN COMMERCE 1-14-2000.

CLASS 36—INSURANCE AND FINANCIAL

FOR FINANCIAL SERVICES, NAMELY, PROVIDING AN ONLINE WEB SITE WITH QUOTATION AND TRADE INFORMATION FOR UNLISTED PUBLICLY TRADED EQUITY SECURITIES; PROVIDING AN ONLINE WEB SITE WITH FINANCIAL INVESTMENT AND MARKET INFORMATION; FINANCIAL SERVICES, NAMELY, PROVIDING FOR OTHERS A QUOTE SUBMISSION PLATFORM THAT ALLOWS USERS TO SUBMIT, UPDATE AND RECEIVE QUOTATIONS AND OTHER INDICATIONS OF TRADING INTEREST FOR INDIVIDUAL FINANCIAL SECURITIES ON A REAL-TIME BASIS (U.S. CLS. 100, 101 AND 102).

FIRST USE 10-31-1988; IN COMMERCE 5-24-1990.
LINDA M. KING, EXAMINING ATTORNEY

SN 85-222,614. CLAUDIO R. BALLARD, FORT LAUDERDALE, FL. FILED 1-20-2011.

ICONIC ULTIMATE BESPOKE

THE MARK CONSISTS OF STANDARD CHARACTERS WITHOUT CLAIM TO ANY PARTICULAR FONT, STYLE, SIZE, OR COLOR.

NO CLAIM IS MADE TO THE EXCLUSIVE RIGHT TO USE "ULTIMATE BESPOKE", APART FROM THE MARK AS SHOWN.

CLASS 35—ADVERTISING AND BUSINESS

FOR RETAIL DEALERSHIP SERVICES FEATURING LAND VEHICLES AND VEHICLE PARTS (U.S. CLS. 100, 101 AND 102).

CLASS 40—MATERIAL TREATMENT

FOR CUSTOM CONSTRUCTION AND ALTERATION OF LAND VEHICLES (U.S. CLS. 100, 103 AND 106).
BRIDGETT SMITH, EXAMINING ATTORNEY

SN 85-224,725. ENCHANTE ACCESSORIES INC., NEW YORK, NY. FILED 1-24-2011.

BELLE MAISON

THE MARK CONSISTS OF STANDARD CHARACTERS WITHOUT CLAIM TO ANY PARTICULAR FONT, STYLE, SIZE, OR COLOR.

THE ENGLISH TRANSLATION OF "BELLE MAISON" IS "BEAUTIFUL HOUSE".

CLASS 3—COSMETICS AND CLEANING PREPARATIONS

FOR HAND LOTION; BODY LOTION; HAND WASH, NAMELY, LIQUID HAND SOAP; SHOWER GEL; BUBBLE BATH; BATH SALTS; BATH FIZZES; BODY SCRUB; BODY SPLASH; LIP GLOSS; NAIL POLISH; EYE SHADOW; NON-ELECTRIC AIR DIFFUSERS COMPRISED OF REEDS AND ROOM FRAGRANCES IN THE NATURE OF SCENTED OILS IN A CONTAINER SOLD AS A UNIT; ROOM FRAGRANCES (U.S. CLS. 1, 4, 6, 50, 51 AND 52).

FIRST USE 8-0-2001; IN COMMERCE 8-0-2001.

CLASS 4—LUBRICANTS AND FUELS

FOR CANDLES (U.S. CLS. 1, 6 AND 15).
FIRST USE 1-7-2010; IN COMMERCE 1-7-2010.
ADA HAN, EXAMINING ATTORNEY

SN 85-226,701. PAYBOX BANK AG, VIENNA, AUSTRIA, FILED 1-26-2011.

PAYBOX

THE MARK CONSISTS OF STANDARD CHARACTERS WITHOUT CLAIM TO ANY PARTICULAR FONT, STYLE, SIZE, OR COLOR.

OWNER OF AUSTRIA REG. NO. 203693, DATED 5-17-2002, EXPIRES 5-31-2012.

CLASS 9—ELECTRICAL AND SCIENTIFIC APPARATUS

FOR APPARATUS FOR RECORDING, TRANSMITTING AND REPRODUCING SOUND AND/OR IMAGES, ESPECIALLY TELECOMMUNICATION APPARATUS; ELECTRONIC APPARATUS FOR DATA TRANSMISSION, ESPECIALLY FOR MAKING PAYMENTS OTHER THAN PAYMENTS IN CASH; CHIP CARDS, MAGNETIC CARDS AND MAGNETIC IDENTITY CARDS AND SMART CARDS, NAMELY, ELECTRONIC COMMUNICATIONS SYSTEMS COMPRISED OF COMPUTER HARDWARE AND SOFTWARE FOR THE TRANSMISSION OF DATA BETWEEN TWO POINTS; DATA PROCESSING COMPUTER PROGRAMS, ESPECIALLY FOR MAKING PAYMENTS OTHER THAN PAYMENTS IN CASH; AUTOMATIC VENDING MACHINES (U.S. CLS. 21, 23, 26, 36 AND 38).

CLASS 35—ADVERTISING AND BUSINESS

FOR DATA PROCESSING SERVICES, NAMELY, PROVIDING OR CARRYING OUT OF DATA PROCESSING, ESPECIALLY TO PROVIDE SERVICES FOR MAKING PAYMENTS OTHER THAN PAYMENTS IN CASH (U.S. CLS. 100, 101 AND 102).

CLASS 36—INSURANCE AND FINANCIAL

FOR CARRYING OUT OF PAYMENT PROCEDURES OTHER THAN IN CASH, NAMELY, PAYMENT PROCESSING SERVICES, NAMELY, CREDIT CARD AND DEBIT CARD TRANSACTION PROCESSING SERVICES; MONETARY TRANSACTIONS OTHER THAN IN CASH, NAMELY, BILL PAYMENT SERVICES THAT ARE CONDUCTED AND AUTHORIZED VIA MOBILE PHONES AND HANDHELD DEVICES, NAMELY, EXECUTION OF MOBILE PAYMENT SERVICES AND ACQUISITION AND TRANSFER OF MONETARY CLAIMS (U.S. CLS. 100, 101 AND 102).

CLASS 38—COMMUNICATION

FOR TELECOMMUNICATION SERVICES, NAMELY, TRANSMISSION OF VOICE, DATA, GRAPHICS, IMAGES, AUDIO AND VIDEO BY MEANS OF TELECOMMUNICATIONS NETWORKS, WIRELESS COMMUNICATION NETWORKS, AND THE INTERNET, NAMELY, PROVIDING OR CARRYING OUT OF TELECOMMUNICATION SERVICES, ESPECIALLY FOR MAKING PAYMENTS OTHER THAN PAYMENTS IN CASH (U.S. CLS. 100, 101 AND 104).

BENJAMIN OKEKE, EXAMINING ATTORNEY

SN 85-228,513. LIFE CARE COMPANIES LLC, DES MOINES, IA. FILED 1-28-2011.

LCS

THE MARK CONSISTS OF STANDARD CHARACTERS WITHOUT CLAIM TO ANY PARTICULAR FONT, STYLE, SIZE, OR COLOR.

CLASS 35—ADVERTISING AND BUSINESS

FOR BUSINESS MANAGEMENT OF RESIDENTIAL COMMUNITIES, CONTINUING CARE COMMUNITIES, ASSISTED LIVING COMMUNITIES AND RETIREMENT COMMUNITIES; BUSINESS DEVELOPMENT OF RESIDENTIAL, CONTINUING CARE, ASSISTED LIVING COMMUNITIES AND RETIREMENT COMMUNITIES; BUSINESS MANAGEMENT AND OPERATION OF CONTINUING CARE RETIREMENT COMMUNITIES (U.S. CLS. 100, 101 AND 102).

CLASS 36—INSURANCE AND FINANCIAL

FOR FINANCIAL MANAGEMENT OF RESIDENTIAL COMMUNITIES, CONTINUING CARE COMMUNITIES, ASSISTED LIVING COMMUNITIES AND RETIREMENT COMMUNITIES (U.S. CLS. 100, 101 AND 102).

CLASS 37—CONSTRUCTION AND REPAIR

FOR REAL ESTATE DEVELOPMENT OF RESIDENTIAL, CONTINUING CARE, ASSISTED LIVING COMMUNITIES AND RETIREMENT COMMUNITIES; PLANNING AND LAYING OUT RESIDENTIAL COMMUNITIES FOR OTHERS; REAL ESTATE DEVELOPMENT SERVICES IN THE FIELD OF CONTINUING CARE RETIREMENT COMMUNITIES (U.S. CLS. 100, 103 AND 106).

CLASS 41—EDUCATION AND ENTERTAINMENT

FOR CONDUCTING ADULT, PROFESSIONAL, NON-DENOMINATIONAL TRAINING PROGRAMS IN THE FIELDS OF HEALTH, FITNESS AND NUTRITION (U.S. CLS. 100, 101 AND 107).

CLASS 43—HOTEL AND RESTAURANT SERVICES

FOR RETIREMENT HOME SERVICES, NAMELY, RETIREMENT HOMES (U.S. CLS. 100 AND 101).

CLASS 44—MEDICAL, BEAUTY AND AGRICULTURAL SERVICES

FOR HOME HEALTH CARE SERVICES; MANAGED HEALTH CARE SERVICES; MEDICAL HEALTH SERVICES, NAMELY, MEDICAL SERVICES; RESIDENTIAL HEALTH CARE SERVICES, NAMELY, HOME HEALTH CARE SERVICES (U.S. CLS. 100 AND 101).

BRENDAN MCCAULEY, EXAMINING ATTORNEY

SN 85-228,604. SET FOR LIFE FINANCIAL, LLC, CHANDLER, AZ. FILED 1-28-2011.

SFL

THE MARK CONSISTS OF STANDARD CHARACTERS WITHOUT CLAIM TO ANY PARTICULAR FONT, STYLE, SIZE, OR COLOR.

CLASS 36—INSURANCE AND FINANCIAL

FOR PROVIDING A WEB-BASED ON-LINE PORTAL FEATURING FINANCIAL MANAGEMENT TOOLS, INFORMATION, RESOURCES, AND SERVICES, NAMELY, AN ONLINE PERSONAL FINANCIAL MANAGEMENT TOOL, WEALTH PLANNING, DEBT REDUCTION, SAVINGS, INVESTMENT INFORMATION, INSURANCE, NAMELY, UNDERWRITING LIFE INSURANCE AND ANNUITIES, TRUSTS AND WILLS, COLLEGE FINANCIAL PLANNING, FINANCIAL PLANNING FOR RETIREMENT, NAMELY, TAXED-ADVANTAGED PLANS, CREDIT SCORE MANAGEMENT, NAMELY, CONSUMER CREDIT CONSULTATION, AND FINANCIAL SERVICES, NAMELY, LOAN DEFAULT MITIGATION SERVICES, MORTGAGE FORECLOSURE SERVICES; PROVIDING FINANCIAL SERVICES, NAMELY, PROVIDING ELECTRONIC PROCESSING OF ACH AND MERCHANT SERVICES AND CREDIT CARD TRANSACTIONS AND ELECTRONIC PAYMENTS VIA A GLOBAL COMPUTER NETWORK; BANKING SERVICES AND ONLINE BANKING SERVICES, NAMELY, TELEPHONE, ONLINE, AND MOBILE DEVICE ACCOUNT MANAGEMENT, MONEY TRANSFER, AND BILL PAY, AND MOBILE AND WEB-BASED ACCESS TO PREPAID DEBIT CARD ACCOUNTS, ACCOUNT BALANCES, ONLINE PERSONAL FINANCIAL MANAGER, AND BUDGET AND SPENDING REPORTS; PROVIDING FINANCIAL INFORMATION (U.S. CLS. 100, 101 AND 102).

FIRST USE 9-0-2008; IN COMMERCE 9-0-2008.

CLASS 41—EDUCATION AND ENTERTAINMENT

FOR FINANCIAL LITERACY EDUCATION, NAMELY, PROVIDING TUTORING AND MENTORING IN THE FIELD OF FINANCE, AND EDUCATIONAL SERVICES, NAMELY, CONDUCTING CLASSES AND SEMINARS IN THE FIELD OF FINANCE AND LIVE AND ON-LINE SEMINARS, ALL IN THE FIELD OF FINANCIAL LITERACY EDUCATION (U.S. CLS. 100, 101 AND 107).

FIRST USE 9-0-2008; IN COMMERCE 9-0-2008.
SCOTT BIBB, EXAMINING ATTORNEY

SN 85-231,148. EDUCATIONAL RECORDS BUREAU, NEW YORK, NY. FILED 2-1-2011.

ISEE INDEPENDENT SCHOOL
ENTRANCE EXAM

OWNER OF U.S. REG. NO. 1,609,062.
THE MARK CONSISTS OF THE LETTERS "ISEE" PLACED TO THE LEFT OF THE WORDS "INDEPENDENT SCHOOL" WHICH APPEAR ABOVE THE WORDS "ENTRANCE EXAM".
SEC. 2(F) AS TO "INDEPENDENT SCHOOL ENTRANCE EXAM".

CLASS 16—PAPER GOODS AND PRINTED MATTER

FOR PRINTED PUBLICATIONS IN THE NATURE OF TEST BOOKLETS, TEST ANSWER SHEETS, MANUALS, PRACTICE BOOKLETS, TEST PREPARATION GUIDES, TEST SCORE REPORTS, INTERPRETATION GUIDES, STUDY GUIDES AND STUDENT GUIDES, INDIVIDUAL STUDENT REPORTS, CERTIFICATION FORMS AND REGISTRATION BOOKLETS IN THE FIELD OF STANDARDIZED TESTS FOR ELEMENTARY AND SECONDARY SCHOOL STUDENTS (U.S. CLS. 2, 5, 22, 23, 29, 37, 38 AND 50).

FIRST USE 2-23-2010, THE MARK WAS FIRST USED ANYWHERE IN A DIFFERENT FORM OTHER THAN THAT SOUGHT TO BE REGISTERED AT LEAST AS EARLY AS 10/00/1988; IN COMMERCE 2-23-2010, THE MARK WAS FIRST USED IN COMMERCE IN A DIFFERENT FORM OTHER THAN THAT SOUGHT TO BE REGISTERED AT LEAST AS EARLY AS 10/00/1988.

CLASS 41—EDUCATION AND ENTERTAINMENT

FOR DEVELOPING, ADMINISTERING AND SCORING EDUCATIONAL TESTS OF ELEMENTARY AND SECONDARY SCHOOL STUDENTS (U.S. CLS. 100, 101 AND 107).

FIRST USE 2-23-2010, THE MARK WAS FIRST USED ANYWHERE IN A DIFFERENT FORM OTHER THAN THAT SOUGHT TO BE REGISTERED AT LEAST AS EARLY AS 10/00/1988; IN COMMERCE 2-23-2010, THE MARK WAS FIRST USED IN COMMERCE IN A DIFFERENT FORM OTHER THAN THAT SOUGHT TO BE REGISTERED AT LEAST AS EARLY AS 10/00/1988.

ARETHA SOMERVILLE, EXAMINING ATTORNEY

SN 85-231,242. LOYALTY MEDIA GROUP LLC, ATLANTA, GA. FILED 2-1-2011.

LOYALTY LIVING ON
YESTERDAY ALWAYS LEADS TO
YESTERDAY

THE MARK CONSISTS OF STANDARD CHARACTERS WITHOUT CLAIM TO ANY PARTICULAR FONT, STYLE, SIZE, OR COLOR.

CLASS 9—ELECTRICAL AND SCIENTIFIC APPARATUS

FOR DVDS AND CDS IN THE FIELD OF ENTERTAINMENT, NAMELY, ANIMATION, DRAMA, COMEDY, SPORTS AND REALITY (U.S. CLS. 21, 23, 26, 36 AND 38).

CLASS 41—EDUCATION AND ENTERTAINMENT

FOR ENTERTAINMENT SERVICES, NAMELY, SCRIPT WRITING SERVICES; TELEVISION SHOW AND MOTION PICTURE FILM PRODUCTION, MUSIC PRODUCTION AND VIDEO PRODUCTION (U.S. CLS. 100, 101 AND 107).
JOHN GARTNER, EXAMINING ATTORNEY

SN 85-232,965. THE COMPETITIVENESS COMPANY LIMITED, KINGSTON 10, JAMAICA, FILED 2-3-2011.

SN 85-233,061. SCIENTIFIC BIO-LOGICS, INC., COSTA MESA, CA. FILED 2-3-2011.



OWNER OF JAMAICA REG. NO. 54,727, DATED 10-28-2010, EXPIRES 11-2-2019.

NO CLAIM IS MADE TO THE EXCLUSIVE RIGHT TO USE "JAMAICA TRAVELS", APART FROM THE MARK AS SHOWN.

THE COLOR(S) GREEN, RED, YELLOW, BLACK, BROWN AND TAN IS/ARE CLAIMED AS A FEATURE OF THE MARK.

THE MARK CONSISTS OF A STYLIZED LUGGAGE TAG IN TAN WITH A BROWN BORDER AND BROWN STRINGS. THE WORDS "MY JAMAICA" TRAVELS WITH A STYLIZED BIRD APPEAR ON THE TAG. THE WORD "MY" IS IN GREEN. THE "JAMAICA" IS IN RED. THE WORD "TRAVELS" IS IN GREEN. THE STYLIZED BIRD IS BLACK WITH GREEN AND YELLOW FEATHERS. THE WING FEATHERS ARE GREEN AND YELLOW IN ALTERNATING STRIPES. THE TAIL FEATHERS OF THE BIRD ARE BLACK.

CLASS 39—TRANSPORTATION AND STORAGE

FOR TRANSPORT AND STORAGE OF GOODS, PACKAGING ARTICLES FOR TRANSPORTATION; TRAVEL ARRANGEMENTS, NAMELY, COORDINATING TRAVEL ARRANGEMENTS FOR INDIVIDUALS AND FOR GROUPS, ARRANGING OF TOURS, TOURIST OFFICE SERVICES (U.S. CLS. 100 AND 105).

FIRST USE 11-0-2009; IN COMMERCE 11-0-2009.

CLASS 41—EDUCATION AND ENTERTAINMENT

FOR EDUCATION SERVICES, NAMELY, SEMINARS, WORKSHOPS, SYMPOSIA IN THE FIELD OF CULTURE, TOURISM, FOOD AND BEVERAGE, HOSPITALITY AND MANAGEMENT; PROVIDING OF TRAINING SERVICES IN THE FIELD OF CULTURAL TOURISM, FOOD AND BEVERAGE, HOSPITALITY AND MANAGEMENT; ENTERTAINMENT IN THE NATURE OF LIVE MUSICAL AND DRAMATIC PERFORMANCES, CONCERTS AND FASHION SHOWS; SPORTING AND CULTURAL ACTIVITIES, NAMELY, ORGANIZING COMMUNITY SPORTING AND CULTURAL EVENTS (U.S. CLS. 100, 101 AND 107).

FIRST USE 11-0-2009; IN COMMERCE 11-0-2009.

CLASS 43—HOTEL AND RESTAURANT SERVICES

FOR SERVICES FOR PROVIDING FOOD AND DRINK, TEMPORARY ACCOMMODATION, TOURIST HOMES (U.S. CLS. 100 AND 101).

FIRST USE 11-0-2009; IN COMMERCE 11-0-2009.
ASMAT KHAN, EXAMINING ATTORNEY

SCIENTIFIC BIO-LOGICS

THE MARK CONSISTS OF STANDARD CHARACTERS WITHOUT CLAIM TO ANY PARTICULAR FONT, STYLE, SIZE, OR COLOR.

NO CLAIM IS MADE TO THE EXCLUSIVE RIGHT TO USE "BIOLOGICS", APART FROM THE MARK AS SHOWN.

CLASS 5—PHARMACEUTICALS

FOR BIOLOGICAL PRODUCTS, NAMELY, NUTRITIONAL SUPPLEMENTS (U.S. CLS. 6, 18, 44, 46, 51 AND 52).

FIRST USE 2-15-1991; IN COMMERCE 2-15-1991.

CLASS 39—TRANSPORTATION AND STORAGE

FOR DISTRIBUTION SERVICES, NAMELY, PACKING FOR TRANSPORTATION, SHIPPING AND DELIVERY OF NUTRITIONAL SUPPLEMENTS, HOMEOPATHIC MEDICINES, AND SKIN CARE PRODUCTS (U.S. CLS. 100 AND 105).

FIRST USE 2-15-1991; IN COMMERCE 2-15-1991.

CHRISTOPHER BUONGIORNO, EXAMINING ATTORNEY

SN 85-233,140. SCIENTIFIC BIO-LOGICS, INC., COSTA MESA, CA. FILED 2-3-2011.



NO CLAIM IS MADE TO THE EXCLUSIVE RIGHT TO USE "BIOLOGICS, INC.", APART FROM THE MARK AS SHOWN.

THE MARK CONSISTS OF THE LETTER "S" IN AN OBLONG DESIGN WITH A WAVY LINE REPRESENTING A LEAF ON THE BOTTOM RIGHT SIDE OF THE LETTER "S"; THE WORDS "SCIENTIFIC BIO-LOGICS, INC." APPEAR IN THE MIDDLE AND TO THE RIGHT OF THE LETTER "S".

CLASS 5—PHARMACEUTICALS

FOR BIOLOGICAL PRODUCTS, NAMELY, NUTRITIONAL SUPPLEMENTS (U.S. CLS. 6, 18, 44, 46, 51 AND 52).

FIRST USE 2-15-1991; IN COMMERCE 2-15-1991.

CLASS 39—TRANSPORTATION AND STORAGE

FOR DISTRIBUTION SERVICES, NAMELY, PACKING FOR TRANSPORTATION, SHIPPING AND DELIVERY OF NUTRITIONAL SUPPLEMENTS, HOMEOPATHIC MEDICINES, AND SKIN CARE PRODUCTS (U.S. CLS. 100 AND 105).

FIRST USE 2-15-1991; IN COMMERCE 2-15-1991.

CHRISTOPHER BUONGIORNO, EXAMINING ATTORNEY

SN 85-235,226. RENOVA ENERGY CORPORATION, PALM DESERT, CA. FILED 2-6-2011.

SN 85-239,803. MULTI-HEALTH SYSTEMS INC., TORONTO, ONTARIO, CANADA, FILED 2-11-2011.

renova

THE MARK CONSISTS OF THE WORD "RENOVA" IN A STYLIZED FONT WITH THE LETTER "O" IN THE SHAPE OF A CIRCULAR ARROW.

CLASS 37—CONSTRUCTION AND REPAIR

FOR INSTALLATION OF SOLAR PHOTOVOLTAIC EQUIPMENT, EXCLUDING COMPUTER REPAIR SERVICES (U.S. CLS. 100, 103 AND 106).

FIRST USE 11-3-2007; IN COMMERCE 11-3-2007.

CLASS 41—EDUCATION AND ENTERTAINMENT

FOR EDUCATIONAL SERVICES, NAMELY, PROVIDING CLASSES, COURSES, SEMINARS, AND ON-SITE AND FIELD TRAINING REGARDING SOLAR PHOTOVOLTAIC PRINCIPLES, PRACTICES, AND TECHNOLOGIES (U.S. CLS. 100, 101 AND 107).

FIRST USE 11-3-2007; IN COMMERCE 11-3-2007.

CORY BOONE, EXAMINING ATTORNEY

EQ-i 2.0

SN 85-236,170. JOHNSTON, CHLOE, DEVON, PA. FILED 2-7-2011.



THE MARK CONSISTS OF INTERTWINED CURSIVE LETTERS "C", "J", AND "T". THERE IS ALSO A SMALL SUITCASE HANGING FROM THE BOTTOM OF THE CURSIVE "T".

CLASS 18—LEATHER GOODS

FOR LUGGAGE TAGS (U.S. CLS. 1, 2, 3, 22 AND 41).

CLASS 25—CLOTHING

FOR SCARVES (U.S. CLS. 22 AND 39).

CLASS 39—TRANSPORTATION AND STORAGE

FOR ARRANGING AND CONDUCTING SHOPPING TOURS (U.S. CLS. 100 AND 105).

DEIRDRE ROBERTSON, EXAMINING ATTORNEY

THE MARK CONSISTS OF STANDARD CHARACTERS WITHOUT CLAIM TO ANY PARTICULAR FONT, STYLE, SIZE, OR COLOR.

PRIORITY CLAIMED UNDER SEC. 44(D) ON CANADA APPLICATION NO. 1494639, FILED 9-3-2010, REG. NO. TMA805328, DATED 8-26-2011, EXPIRES 8-26-2026.

OWNER OF U.S. REG. NOS. 2,486,427, 2,888,154 AND 2,932,228.

CLASS 16—PAPER GOODS AND PRINTED MATTER

FOR A PSYCHOLOGICAL ASSESSMENT TOOL, NAMELY, PRINTED BOOKLETS, QUESTIONNAIRES, INTERVIEW FORMS, WORKBOOKS, SCORING FORMS, ANSWER KEYS, PROFILE SHEETS, REPORT FORMS AND MANUALS, ALL USED TO DETECT BEHAVIORAL DISORDERS AND AUTOMATICALLY GENERATE INTERPRETATION REPORTS AND TREATMENT MEASURES USING COMPUTER SOFTWARE AND WEB-BASED TECHNOLOGY (U.S. CLS. 2, 5, 22, 23, 29, 37, 38 AND 50).

CLASS 41—EDUCATION AND ENTERTAINMENT

FOR EDUCATIONAL TRAINING WORKSHOPS, IN THE FIELD OF PSYCHOLOGICAL TESTING, AND DISTRIBUTION OF COURSE AND EDUCATIONAL MATERIALS IN CONNECTION THEREWITH, NAMELY, COMPUTER SOFTWARE AND PRINTED BOOKLETS, QUESTIONNAIRES, INTERVIEW FORMS, WORKBOOKS, SCORING FORMS, ANSWER KEYS, PROFILE SHEETS, REPORT FORMS AND MANUALS (U.S. CLS. 100, 101 AND 107).

CLASS 44—MEDICAL, BEAUTY AND AGRICULTURAL SERVICES

FOR PSYCHOLOGICAL TESTING AND CONSULTATION SERVICES (U.S. CLS. 100 AND 101).

CURTIS FRENCH, EXAMINING ATTORNEY

SN 85-245,003. SANGHATA INSTITUTE FOR SOCIAL ENTREPRENEURSHIP AND INVESTMENT, NEW YORK, NY. FILED 2-17-2011.



NO CLAIM IS MADE TO THE EXCLUSIVE RIGHT TO USE "INSTITUTE FOR SOCIAL ENTREPRENEURSHIP AND INVESTMENT", APART FROM THE MARK AS SHOWN.

THE MARK CONSISTS OF THE FOLLOWING: A CONCENTRIC CIRCULAR DESIGN WITH A MULTITUDE OF SPOKES EMANATING FROM THE INTERIOR CIRCLE TO A SECOND OUTER CIRCLE. CIRCUMSCRIBING THE SECOND OUTER CIRCLE IS THE WORDING "SANGHATA INSTITUTE FOR SOCIAL ENTREPRENEURSHIP AND INVESTMENT" ALL ENCOMPASSED BY A THIRD OUTER CIRCLE.

THE ENGLISH TRANSLATION OF THE SANSKRIT TERM "SANGHATA" IN THE MARK IS "TRANSFORMING THROUGH JOINING AND CONNECTING".

CLASS 35—ADVERTISING AND BUSINESS

FOR ASSISTANCE WITH BUSINESS MANAGEMENT AND PLANNING; BUSINESS ADVICE AND INFORMATION; BUSINESS AND CONSULTATION SERVICES; PROMOTION OF BUSINESS ENTERPRISES IN LOW-INCOME COUNTRIES; ONLINE BUSINESS NETWORKING SERVICES, NAMELY, PROVIDING A GLOBAL NETWORK WHICH FACILITATES THE ASSOCIATION OF ENTREPRENEURS, MANAGEMENT TALENTS AND INVESTORS (U.S. CLS. 100, 101 AND 102).

CLASS 36—INSURANCE AND FINANCIAL

FOR FINANCIAL ADVICE (U.S. CLS. 100, 101 AND 102).

CLASS 41—EDUCATION AND ENTERTAINMENT

FOR EDUCATIONAL SERVICES, NAMELY, PROVIDING EDUCATIONAL AND TRAINING PROGRAMS AND FACILITIES IN THE FIELDS OF SOCIAL ENTREPRENEURSHIP, BUSINESS DEVELOPMENT, BUSINESS MANAGEMENT, BUSINESS CONSULTATION AND FINANCIAL ADVICE (U.S. CLS. 100, 101 AND 107).
WILLIAM P. SHANAHAN, EXAMINING ATTORNEY

SN 85-247,254. SAVANNAH BEE COMPANY, INC., SAVANNAH, GA. FILED 2-21-2011.



OWNER OF U.S. REG. NOS. 3,173,099 AND 3,293,961.

NO CLAIM IS MADE TO THE EXCLUSIVE RIGHT TO USE "SAVANNAH" AND "COMPANY", APART FROM THE MARK AS SHOWN.

THE MARK CONSISTS OF THE WORDS "SAVANNAH BEE COMPANY" IN A STYLIZED FONT AND STARTING FROM THE BOTTOM LEFT GOES CLOCKWISE TO THE BOTTOM RIGHT FORMING ALMOST A COMPLETE CIRCLE. WITHIN THE CIRCLE ARE THREE BEES WITH THEIR HEADS FACING INWARD TO CREATE A CIRCLE.

CLASS 3—COSMETICS AND CLEANING PREPARATIONS

FOR COSMETICS, PERSONAL CARE PRODUCTS, NAMELY, LIP BALM, TINTED LIP BALM, NON-MEDICATED HAND AND NAIL SALVE, HAND CREAM, HAND LOTION, HAND SOAP, BODY LOTION, BODY BUTTER, BODY WASH, FOOT LOTION, BODY SCRUB (U.S. CLS. 1, 4, 6, 50, 51 AND 52).

FIRST USE 1-1-2002; IN COMMERCE 1-1-2002.

CLASS 30—STAPLE FOODS

FOR HONEY (U.S. CL. 46).

FIRST USE 1-1-2002; IN COMMERCE 1-1-2002.

CLASS 35—ADVERTISING AND BUSINESS

FOR RETAIL STORE SERVICES, MAIL ORDER RETAIL SERVICES AND ONLINE RETAIL STORE SERVICES IN THE FIELDS OF PERSONAL CARE PRODUCTS, COSMETICS, HOME FRAGRANCE PRODUCTS AND ACCESSORIES AND HONEY (U.S. CLS. 100, 101 AND 102).

FIRST USE 1-1-2002; IN COMMERCE 1-1-2002.

KAPIL BHANOT, EXAMINING ATTORNEY

SN 85-250,088. CELSYA, LLC, LOS ANGELES, CA. FILED 2-23-2011.

CELSYA

THE MARK CONSISTS OF STANDARD CHARACTERS WITHOUT CLAIM TO ANY PARTICULAR FONT, STYLE, SIZE, OR COLOR.

CLASS 9—ELECTRICAL AND SCIENTIFIC APPARATUS

FOR MOBILE ELECTRONIC DEVICES USED FOR STORAGE, RETRIEVAL, AND TRANSMISSION OF PERSONAL HEALTH INFORMATION, NAMELY, BUT NOT LIMITED TO MEDICATIONS, DIAGNOSES, PROVIDERS, ADVANCE DIRECTIVES, MEDICAL ALERTS, MEDICAL HISTORY, TREATMENTS AND SURGERIES, AND EMERGENCY NOTIFICATION, FOR INDIVIDUALS, THEIR FAMILY MEMBERS, AND OTHERS; COMPUTER HARDWARE FOR WIRELESS CONTENT DELIVERY IN THE MEDICAL FIELD; WIRELESS COMMUNICATION DEVICE FEATURING VOICE, DATA AND IMAGE TRANSMISSION NAMELY, VOICE, TEXT AND PICTURE MESSAGING, A VIDEO AND STILL IMAGE CAMERA; WIRELESS COMMUNICATION DEVICES FOR VOICE, DATA OR IMAGE TRANSMISSION; COMPUTER SOFTWARE, NAMELY, AN APPLICATION ALLOWING CONSUMERS AND MEDICAL PROFESSIONALS TO UPDATE AND RECEIVE DATA STORED IN AN ENTERPRISE'S COMPUTER DATABASES IN REAL TIME, USING A MOBILE DEVICE, WITH FULL TELEPHONY INTEGRATION WITH THE TELEPHONE AND/OR SOFTWARE FEATURES OF THE MOBILE DEVICE; COMPUTER SOFTWARE FOR WIRELESS CONTENT DELIVERY; COMPUTER SOFTWARE FOR CONTROLLING AND MANAGING PATIENT MEDICAL INFORMATION; COMPUTER HARDWARE FOR RECEIVING, PROCESSING, TRANSMITTING AND DISPLAYING DATA AND CONTROLLING AND MANAGING PATIENT MEDICAL INFORMATION; COMPUTER SOFTWARE FOR RECEIVING, PROCESSING, TRANSMITTING AND DISPLAYING DATA AND CONTROLLING AND MANAGING PATIENT MEDICAL INFORMATION; COMPUTER OPERATING SOFTWARE FOR PATIENT SERVICES PORTALS IN THE HEALTHCARE INDUSTRY; COMPUTER HARDWARE AND SOFTWARE FOR CONTROLLING AND MANAGING MEDICAL SYSTEMS, TECHNOLOGY, DATA AND PATIENT RECORDS; COMPUTER APPLICATION SOFTWARE FOR MOBILE PHONES, MOBILE DEVICES, AND HANDHELD COMPUTERS, NAMELY, SOFTWARE FOR CONTROLLING AND MANAGING MEDICAL SYSTEMS, TECHNOLOGY, DATA AND PATIENT RECORDS; COMPUTER APPLICATION SOFTWARE FOR MOBILE PHONES, MOBILE DEVICES, AND HANDHELD COMPUTERS, NAMELY, SOFTWARE FOR INTERACTIVE MEDICAL MONITORING AND ALERT SERVICES AND FOR REMINDING CLIENTS OF MEDICAL INFORMATION, NAMELY, MEDICINAL DOSAGE, ALLERGIC SENSITIVITY, PRESCRIPTION REFILLS, AND MEDICAL APPOINTMENTS; PERSONAL DIGITAL ASSISTANTS (PDA); PROTECTIVE CARRYING CASES SPECIALLY ADAPTED FOR PERSONAL DIGITAL ASSISTANTS (PDA); SMARTPHONES; HANDHELD PERSONAL COMPUTERS; ACCESSORIES SPECIALLY ADAPTED FOR USE WITH MOBILE PHONES, MOBILE DEVICES, HANDHELD COMPUTERS, SMARTPHONES, AND PERSONAL DIGITAL ASSISTANTS (PDAS), NAMELY, BELT CLIPS, HOLSTERS, AND CARRYING CASES; PC TABLETS; TABLET COMPUTERS; COMPUTER SOFTWARE FOR THE TRANSMISSION OF AUDIO, VIDEO, AND AUDIO-VISUAL MATERIAL, SHORT MESSAGES, MULTIMEDIA MESSAGES, TEXT AND GRAPHICS TO WEBSITES, WIRELESS ACCESS POINT (WAP) WEBSITES, NAMELY, WEBSITES ACCESSIBLE BY WAP DEVICES, WIRELESS NETWORKS, MOBILE PHONES, MOBILE DEVICES, WAP PHONES, SMART PHONES, PDAS, HANDHELD COMPUTERS, LAPTOPS, MOBILE ELECTRONIC DEVICES, AND OTHER MOBILE ELECTRONIC HANDHELD DEVICES; RECEIVERS USED FOR CAPTURING AND TRANSMITTING ELECTRONIC SPORT, FITNESS, AND ACTIVITY DATA FROM AN ELECTRONIC SENSOR WHICH SENSES THE FITNESS DATA, NAMELY, DATA REGARDING TIME, PACE, SPEED, STEPS TAKEN, ATHLETIC SKILL, CALORIES BURNED, HEART AND BODY RATE, GLOBAL POSITIONING, DIRECTION, DISTANCE, ALTITUDE, NAVIGATIONAL AND WEATHER INFORMATION; RECEIVERS USED FOR CAPTURING AND TRANSMITTING ELECTRONIC MEDICAL DATA FROM AN ELECTRONIC SENSOR WHICH SENSES WEARER'S BLOOD PRESSURE, HEART AND BODY RATE, GLUCOSE LEVEL, OXYGEN LEVEL, VITAL SIGNS, WEIGHT, AND BODY TEMPERATURE; RECEIVERS USED FOR CAPTURING AND TRANSMITTING ELECTRONIC MEDICAL DATA FROM AN ELECTRONIC SENSOR FOR REMINDING WEARERS OF MEDI-

CAL INFORMATION, NAMELY, MEDICINAL DOSAGE, ALLERGIC SENSITIVITY, PRESCRIPTION REFILLS, AND MEDICAL APPOINTMENTS; ELECTRONIC MONITORING DEVICES INCORPORATING MICROPROCESSORS, DIGITAL DISPLAY, AND ACCELEROMETERS, FOR DETECTING, STORING, REPORTING, MONITORING, UPLOADING AND DOWNLOADING SPORT, FITNESS, AND ACTIVITY DATA TO THE INTERNET, AND COMMUNICATION WITH PERSONAL COMPUTERS, REGARDING TIME, PACE, SPEED, STEPS TAKEN, ATHLETIC SKILL, CALORIES BURNED, HEART AND BODY RATE, GLOBAL POSITIONING, DIRECTION, DISTANCE, ALTITUDE, NAVIGATIONAL AND WEATHER INFORMATION; COMPUTER SOFTWARE FOR FITNESS AND WEIGHT MANAGEMENT; CASES, STRAPS, WRIST AND ARM BANDS FOR ELECTRONIC MONITORING DEVICES; COMPUTER SOFTWARE FOR CAPTURING AND TRANSMITTING ELECTRONIC SPORT, FITNESS, AND ACTIVITY DATA FROM AN ELECTRONIC SENSOR WHICH SENSES THE FITNESS DATA, NAMELY, DATA REGARDING TIME, PACE, SPEED, STEPS TAKEN, ATHLETIC SKILL, CALORIES BURNED, HEART AND BODY RATE, GLOBAL POSITIONING, DIRECTION, DISTANCE, ALTITUDE, NAVIGATIONAL AND WEATHER INFORMATION; COMPUTER SOFTWARE FOR CAPTURING AND TRANSMITTING ELECTRONIC MEDICAL DATA FROM AN ELECTRONIC SENSOR WHICH SENSES WEARER'S BLOOD PRESSURE, HEART AND BODY RATE, GLUCOSE LEVEL, OXYGEN LEVEL, VITAL SIGNS, WEIGHT, AND BODY TEMPERATURE; COMPUTER SOFTWARE FOR CAPTURING AND TRANSMITTING ELECTRONIC MEDICAL DATA FROM AN ELECTRONIC SENSOR FOR REMINDING WEARERS OF MEDICAL INFORMATION, NAMELY, MEDICINAL DOSAGE, ALLERGIC SENSITIVITY, PRESCRIPTION REFILLS, AND MEDICAL APPOINTMENTS; COMPUTER APPLICATION SOFTWARE FOR MOBILE PHONES, MOBILE DEVICES, AND HANDHELD COMPUTERS FOR CAPTURING AND TRANSMITTING ELECTRONIC SPORT, FITNESS, AND ACTIVITY DATA FROM AN ELECTRONIC SENSOR WHICH SENSES THE FITNESS DATA, NAMELY, DATA REGARDING TIME, PACE, SPEED, STEPS TAKEN, ATHLETIC SKILL, CALORIES BURNED, HEART AND BODY RATE, GLOBAL POSITIONING, DIRECTION, DISTANCE, ALTITUDE, NAVIGATIONAL AND WEATHER INFORMATION; COMPUTER APPLICATION SOFTWARE FOR MOBILE PHONES, MOBILE DEVICES, AND HANDHELD COMPUTERS FOR CAPTURING AND TRANSMITTING ELECTRONIC MEDICAL DATA FROM AN ELECTRONIC SENSOR WHICH SENSES WEARER'S BLOOD PRESSURE, HEART AND BODY RATE, GLUCOSE LEVEL, OXYGEN LEVEL, VITAL SIGNS, WEIGHT, AND BODY TEMPERATURE; COMPUTER APPLICATION SOFTWARE FOR MOBILE PHONES, MOBILE DEVICES, AND HANDHELD COMPUTERS FOR CAPTURING AND TRANSMITTING ELECTRONIC MEDICAL DATA FROM AN ELECTRONIC SENSOR WHICH SENSES WEARER'S BLOOD PRESSURE, HEART AND BODY RATE, GLUCOSE LEVEL, OXYGEN LEVEL, VITAL SIGNS, WEIGHT, AND BODY TEMPERATURE; COMPUTER APPLICATION SOFTWARE FOR MOBILE PHONES, MOBILE DEVICES, AND HANDHELD COMPUTERS FOR CAPTURING AND TRANSMITTING ELECTRONIC MEDICAL DATA FROM AN ELECTRONIC SENSOR FOR REMINDING WEARERS OF MEDICAL INFORMATION, NAMELY, MEDICINAL DOSAGE, ALLERGIC SENSITIVITY, PRESCRIPTION REFILLS, AND MEDICAL APPOINTMENTS; COMPUTER APPLICATION SOFTWARE FOR MOBILE PHONES, MOBILE DEVICES, AND HANDHELD COMPUTERS, NAMELY, SOFTWARE FOR DATABASE MANAGEMENT, NAMELY, ELECTRONIC CAPTURE, STORAGE, RETRIEVAL, AND UPDATING OF PERSONAL HEALTH INFORMATION, NAMELY, BUT NOT LIMITED TO MEDICATIONS, DIAGNOSES, PROVIDERS, ADVANCE DIRECTIVES, MEDICAL ALERTS, MEDICAL HISTORY, TREATMENTS AND SURGERIES, AND EMERGENCY NOTIFICATION, FOR INDIVIDUALS, THEIR FAMILY MEMBERS, AND OTHERS WHO WISH TO BE INCLUDED IN THE DATABASE IN ORDER TO FACILITATE AND EFFECTUATE TRANSMISSION OF ACCURATE PATIENT INFORMATION VIA PHONE, EMAIL, AND OTHER CONDUITS FOR PURPOSES OF TREATMENT; COMPUTER SOFTWARE, NAMELY, SOFTWARE FOR DATABASE MANAGEMENT, NAMELY, ELECTRONIC CAPTURE, STORAGE, RETRIEVAL, AND UPDATING OF PERSONAL HEALTH INFORMATION, NAMELY, BUT NOT LIMITED TO MEDICATIONS, DIAGNOSES, PROVIDERS, ADVANCE DIRECTIVES, MEDICAL ALERTS, MEDICAL HISTORY, TREATMENTS AND SURGERIES, AND EMERGENCY NOTIFICATION, FOR INDIVIDUALS, THEIR FAMILY MEMBERS, AND OTHERS WHO WISH TO BE INCLUDED IN THE DATABASE IN ORDER TO FACIL-

ITATE AND EFFECTUATE TRANSMISSION OF ACCURATE PATIENT INFORMATION VIA PHONE, EMAIL, AND OTHER CONDUITS FOR PURPOSES OF TREATMENT (U.S. CLS. 21, 23, 26, 36 AND 38).

CLASS 44—MEDICAL, BEAUTY AND AGRICULTURAL SERVICES

FOR INTERACTIVE MEDICAL MONITORING AND ALERT SERVICE FOR REMINDING CLIENTS OF MEDICAL INFORMATION, NAMELY, MEDICINAL DOSAGE, ALLERGIC SENSITIVITY, PRESCRIPTION REFILLS, AND MEDICAL APPOINTMENTS; MEDICAL INFORMATION SERVICES, NAMELY, REPORTING OF CONSUMER AUTHORIZED CLINICAL TESTING RESULTS DIRECTLY TO THE PATIENT; MAINTAINING FILES AND RECORDS CONCERNING THE MEDICAL CONDITION OF INDIVIDUALS; PROVIDING AN INTERNET WEB SITE FOR MAINTAINING FILES AND RECORDS CONCERNING THE MEDICAL CONDITION OF INDIVIDUALS; MAINTAINING PATIENT MEDICAL RECORDS AND FILES; MAINTAINING PERSONAL MEDICAL HISTORY RECORDS AND FILES; MEDICAL AND PHARMACEUTICAL CONSULTATION; MEDICAL ASSISTANCE SERVICES PROVIDED VIA TELECOMMUNICATION AND GLOBAL COMPUTER NETWORKS FOR INDIVIDUALS WITH HEALTH PROBLEMS THROUGH THE USE OF WEARABLE MEDICAL DEVICES WITH AUTOMATED ALERT AND MONITORING CAPACITY; PROVIDING A WEB SITE FEATURING MEDICAL INFORMATION; PROVIDING A WEB SITE FEATURING INFORMATION ON HEALTH AND NUTRITION; PROVIDING AN INTERNET WEB SITE FOR MEDICAL PROFESSIONALS AND MEDICAL PATIENTS THAT ALLOWS FOR THE EXCHANGE OF INFORMATION FROM REMOTE LOCATIONS USING DEVICES THAT FEED INFORMATION TO THE WEB SITE THAT IS THEN PROCESSED AND CAN BE ACCESSED IN REAL-TIME BY USERS; PROVIDING AN INTERNET WEB SITE FOR MEDICAL PROFESSIONALS AND MEDICAL PATIENTS THAT ALLOWS FOR THE EXCHANGE OF INFORMATION FROM REMOTE LOCATIONS USING ELECTRONIC PATIENT MONITORING DEVICES THAT FEED INFORMATION TO THE WEB SITE THAT CAN BE ACCESSED IN REAL-TIME BY MEDICAL PROFESSIONALS FOR PURPOSES OF MONITORING AND DIAGNOSING MEDICAL CONDITIONS; HEALTH CARE SERVICES, NAMELY, PROVIDING A DATABASE IN THE FIELD OF CANCER, CARDIOVASCULAR, INTERNAL MEDICINE, PEDIATRICS, ORTHOPEDICS, SURGERY, KIDNEY DISEASE, AUTISM, MEDICATION MANAGEMENT, HEALTH COACHING, ORGAN TRANSPLANT, PALLIATIVE CARE, PAIN MANAGEMENT, GERIATRICS, OBSTETRICS, RADIOLOGY, AND WELLNESS AND FITNESS INFORMATION AND FEATURING INPUTTING AND COLLECTION OF DATA AND INFORMATION ALL FOR TREATMENT AND DIAGNOSTIC PURPOSES; PROVIDING AN INTERNET-BASED DATABASE OF PATIENT MEDICAL INFORMATION WHERE PATIENTS CAN INQUIRE ABOUT MEDICAL ISSUES, MEDICATIONS, DOSAGES, PRESCRIPTION REFILLS, AND MONITORING OF PATIENT VITAL SIGNS; PROVIDING AN INTERNET-BASED DATABASE OF PATIENT MEDICAL INFORMATION WHERE PATIENTS CAN INQUIRE ABOUT MEDICAL ISSUES AND PROCEDURES FROM OTHER PATIENTS AND CAN RELAY INFORMATION ABOUT THEIR MEDICAL EXPERIENCES FOR SUPPORT AND COMMUNITY; PROVIDING AN ON-LINE, PATIENT-INITIATED, PATIENT-AUTHORIZED, MEDICAL PROFILE AND MEDICAL RECORD ANALYSIS SERVICE DESIGNED TO PROVIDE PATIENTS WITH CUSTOM TAILORED INFORMATION ABOUT THE RANGE OF POSSIBLE DIAGNOSES AND THERAPIES ASSOCIATED WITH A DEFINED SET OF SYMPTOMS; PROVIDING ON-LINE MEDICAL RECORD ANALYSIS SERVICES DESIGNED TO PROVIDE PATIENTS WITH CUSTOM TAILORED INFORMATION ABOUT THE RANGE OF POSSIBLE DIAGNOSES AND THERAPIES ASSOCIATED WITH A DEFINED SET OF SYMPTOMS; PROVIDING AN ON-LINE COMPUTER DATABASE FEATURING INFORMATION REGARDING HEALTH; PROVIDING CUSTOMIZABLE PATIENT PLANS, NAMELY, WEBSITES FEATURING TREATMENT AND REHABILITATION PLANS FOR PATIENTS AND NON-DOWNLOADABLE EDUCATIONAL INFORMATION REGARDING RELATED HEALTH ISSUES; FACILITATING REMOTE INTERACTIONS BETWEEN PATIENTS AND

HEALTHCARE PROFESSIONALS, NAMELY, PROVIDING WEB-BASED PORTALS ACCESSIBLE BY PATIENTS AND HEALTHCARE PROVIDERS TO DISCUSS TREATMENT AND REHABILITATION PLANS FOR PATIENTS; PROVIDING CUSTOMIZABLE DATABASES OF PATIENT RECORDS; HEALTH CARE SERVICES, NAMELY, PROVIDING A DATABASE IN THE FIELD OF HEALTH RISK ASSESSMENT AND FEATURING INPUTTING AND COLLECTION OF DATA AND INFORMATION ALL FOR TREATMENT AND DIAGNOSTIC PURPOSES; HEALTH CARE SERVICES, NAMELY, PROVIDING RECOMMENDED HEALTH CARE-RELATED SCREENINGS AND OTHER HEALTH CARE-RELATED RECOMMENDATIONS BASED UPON FAMILY HISTORY, PATIENT HEALTH PROFILE, DEMOGRAPHICS, EATING HABITS, AND LIFESTYLE; PROVIDING HEALTH CARE CONSULTATION SERVICES OVER THE INTERNET; PROVISION OF MEDICAL SERVICES BY HEALTH CARE PROFESSIONALS VIA THE INTERNET OR TELECOMMUNICATION NETWORKS; PROVIDING MEDICAL PROFILES AND MEDICAL RECORD ANALYSIS AND ASSESSMENTS VIA A WEBSITE THAT ARE DESIGNED TO PROVIDE CUSTOM TAILORED OUTPUTS ABOUT RECOMMENDED RESOURCES AND TREATMENTS ASSOCIATED WITH A DEFINED SET OF SYMPTOMS AND CONCERNS; WEB-BASED CARDIOVASCULAR EXAMINATION AND ASSESSMENT FOR MEDICAL DIAGNOSTIC PURPOSES; WEB-BASED CARDIOVASCULAR ANALYSIS SERVICES FOR MEDICAL DIAGNOSTIC AND TREATMENT PURPOSES; PROVIDING AN INTERNET WEB SITE FOR TRACKING AND TRANSMITTING ELECTRONIC SPORT, FITNESS, AND ACTIVITY DATA, NAMELY, DATA REGARDING TIME, PACE, SPEED, STEPS TAKEN, ATHLETIC SKILL, CALORIES BURNED, HEART AND BODY RATE, GLOBAL POSITIONING, DIRECTION, DISTANCE, ALTITUDE, NAVIGATIONAL AND WEATHER INFORMATION; PROVIDING AN INTERNET WEB SITE FOR TRACKING AND TRANSMITTING ELECTRONIC MEDICAL DATA, NAMELY, BLOOD PRESSURE, HEART AND BODY RATE, GLUCOSE LEVEL, OXYGEN LEVEL, VITAL SIGNS, WEIGHT, AND BODY TEMPERATURE; PROVIDING AN INTERNET WEB SITE FOR TRACKING AND TRANSMITTING ELECTRONIC MEDICAL DATA, NAMELY, MEDICINAL DOSAGE, ALLERGIC SENSITIVITY, AND PRESCRIPTION REFILLS; PROVIDING AN INTERNET WEB SITE FOR FITNESS AND WEIGHT MANAGEMENT; PROVIDING AN INTERNET WEB SITE FOR STORAGE, RETRIEVAL, AND UPDATING OF PERSONAL HEALTH INFORMATION, NAMELY, BUT NOT LIMITED TO MEDICATIONS, DIAGNOSES, PROVIDERS, ADVANCE DIRECTIVES, MEDICAL ALERTS, MEDICAL HISTORY, TREATMENTS AND SURGERIES, AND EMERGENCY NOTIFICATION, FOR INDIVIDUALS, THEIR FAMILY MEMBERS, AND ANY OTHER PERSONS WHO WISH TO BE INCLUDED IN THE DATABASE IN ORDER TO FACILITATE AND EFFECTUATE TRANSMISSION OF ACCURATE PATIENT INFORMATION VIA PHONE, EMAIL, AND OTHER CONDUITS FOR PURPOSES OF TREATMENT (U.S. CLS. 100 AND 101).

DOMINICK J. SALEMI, EXAMINING ATTORNEY

SN 85-251,319. WIENER, DAVID S., DBA LCMS PLUS, INC., CHAPEL HILL, NC. AND WOOD, ALLISON E., DBA LCMS PLUS, INC., CHAPEL HILL, NC. FILED 2-24-2011.

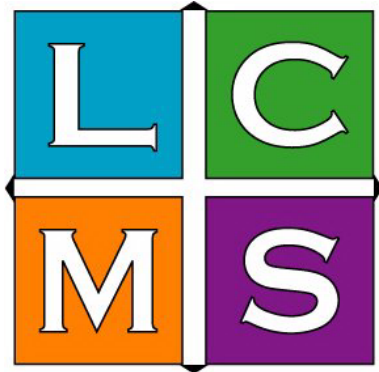

THE COLOR(S) BLACK, WHITE, CYAN, GREEN, ORANGE AND PURPLE IS/ARE CLAIMED AS A FEATURE OF THE MARK.

THE MARK CONSISTS OF FOUR UPPERCASE LETTERS IN WHITE WITH BLACK OUTLINING, FLOATING IN SEPARATE SQUARE COLOR BLOCKS OUTLINED IN BLACK WHICH TOGETHER CONSTITUTE A LARGER SQUARE: CAPITAL "L" IN TOP LEFT CORNER, CYAN BLOCK; CAPITAL "C" IN TOP RIGHT CORNER, GREEN BLOCK; CAPITAL "M" IN BOTTOM LEFT CORNER, ORANGE BLOCK; CAPITAL "S" IN BOTTOM RIGHT CORNER, PURPLE BLOCK. TWO WHITE PERPENDICULAR LINES BISECT THE BLOCKS, IN THE SHAPE OF A PLUS SIGN, WITH BLACK ARROWHEADS ON THE ENDPOINTS.

CLASS 9—ELECTRICAL AND SCIENTIFIC APPARATUS

FOR COMPUTER SOFTWARE PLATFORMS FOR USERS IN THE FIELD OF EDUCATION TO MANAGE CURRICULUM, NAMELY, TO DISSEMINATE, ADMINISTER AND MANAGE COURSE REGISTRATION INFORMATION, COURSE CONTENT, DIGITAL AND AUDIO COURSE CONTENT, VIDEO CONTENT, AUDIO CONTENT, CAMPUS EVENTS, CALENDARS, NEWS, SCHEDULES, DIRECTORIES, MAPS, DATA; COMPUTER SOFTWARE PLATFORMS FOR USERS IN THE FIELD OF EDUCATION TO MANAGE CURRICULUM, NAMELY, TO ALLOW FOR THE ADMINISTRATION AND MANAGEMENT OF EDUCATIONAL COURSES, BULLETIN BOARDS, CHAT ROOMS, EXAMS AND ASSESSMENTS, DATABASE RESOURCES AND SEARCHING, BROWSING, INDEXING, FILTERING AND RETRIEVAL OF DATA AND CONTENT OF COMPUTERS, COMPUTER NETWORKS AND THE INTERNET, BOTH ONLINE AND OFFLINE; COMPUTER SOFTWARE PLATFORMS FOR USERS IN THE FIELD OF EDUCATION TO MANAGE CURRICULUM, NAMELY, TO ENABLE STUDENTS TO REGISTER FOR COURSES, PLAN SCHEDULES, ENGAGE IN COMMUNITY AND SOCIAL ACTIVITIES, MANAGE MOBILE CONTENT, SEARCH IMAGE COLLECTIONS, SEARCH LIBRARY CATALOGS, AND ESTABLISH LIVE CONNECTIONS WITH OTHER STUDENTS AND VARIOUS UNIVERSITY DEPARTMENTS FOR LIVE CHAT, LIVE HELP, TROUBLESHOOTING, AND OTHER PURPOSES; COMPUTER SOFTWARE PLATFORMS FOR USERS IN THE FIELD OF EDUCATION TO MANAGE CURRICULUM, NAMELY, TO ENABLE EMPLOYEES TO PLAN SCHEDULES, ENGAGE IN EMPLOYMENT-RELATED COMMUNITY AND SOCIAL ACTIVITIES, MANAGE MOBILE CONTENT, AND ESTABLISH LIVE CONNECTIONS WITH OTHER EMPLOYEES AND OFFICES (U.S. CLS. 21, 23, 26, 36 AND 38).

CLASS 42—SCIENTIFIC AND COMPUTER SERVICES

FOR APPLICATION SERVICE PROVIDERS (ASP) FEATURING SOFTWARE FOR USERS IN THE FIELD OF EDUCATION TO MANAGE CURRICULUM, NAMELY, TO DISSEMINATE, ADMINISTER AND MANAGE COURSE REGISTRATION INFORMATION, COURSE CONTENT, DIGITAL AND AUDIO COURSE CONTENT, VIDEO CONTENT, AUDIO CONTENT, CAMPUS EVENTS, CALENDARS, NEWS, SCHEDULES, DIRECTORIES, MAPS, DATA, TO ALLOW FOR THE ADMINISTRATION AND MANAGEMENT OF EDUCATIONAL COURSES, BULLETIN BOARDS, CHAT ROOMS, EXAMS AND ASSESSMENTS, DATABASE RESOURCES AND SEARCHING, BROWSING, INDEXING, FILTERING AND RETRIEVAL OF DATA AND CONTENT OF COMPUTERS, COMPUTER NETWORKS AND THE INTERNET, BOTH ONLINE AND OFFLINE; COMPUTER SOFTWARE DEVELOPMENT AND COMPUTER PROGRAMMING DEVELOPMENT FOR OTHERS IN THE FIELD OF EDUCATION TO MANAGE CURRICULUM, NAMELY, TO CUSTOMIZE AND MODIFY TOOLS, APPLICATIONS AND FUNCTIONS TO ENABLE MORE ACCURATE COLLECTION, ASSESSMENT, TRACKING AND REPORTING OF DATA; APPLICATION SERVICE PROVIDERS (ASP) FEATURING SOFTWARE FOR USERS IN THE FIELD OF EDUCATION TO MANAGE CURRICULUM, NAMELY, TO ENABLE STUDENTS TO REGISTER FOR COURSES, PLAN SCHEDULES, ENGAGE IN COMMUNITY AND SOCIAL ACTIVITIES, MANAGE MOBILE CONTENT, SEARCH IMAGE COLLECTIONS, SEARCH LIBRARY CATALOGS, AND ESTABLISH LIVE CONNECTIONS WITH OTHER STUDENTS AND VARIOUS UNIVERSITY DEPARTMENTS FOR LIVE CHAT, LIVE HELP, TROUBLESHOOTING, AND OTHER PURPOSES; APPLICATION SERVICE PROVIDERS (ASP) FEATURING SOFTWARE FOR USERS IN THE FIELD OF EDUCATION TO MANAGE CURRICULUM, NAMELY, TO ENABLE EMPLOYEES TO PLAN SCHEDULES, ENGAGE IN EMPLOYMENT-RELATED COMMUNITY AND SOCIAL ACTIVITIES, MANAGE MOBILE CONTENT, AND ESTABLISH LIVE CONNECTIONS WITH OTHER EMPLOYEES AND OFFICES (U.S. CLS. 100 AND 101).

MARY BOAGNI, EXAMINING ATTORNEY

SN 85-252,584. SCHWARTZ, STEPHANIE, SOUTHPORT, CT. FILED 2-26-2011.

GRIN

THE MARK CONSISTS OF STANDARD CHARACTERS WITHOUT CLAIM TO ANY PARTICULAR FONT, STYLE, SIZE, OR COLOR.

CLASS 9—ELECTRICAL AND SCIENTIFIC APPARATUS

FOR DIGITAL MATERIALS, NAMELY, DOWNLOADABLE MULTIMEDIA FILES FEATURING TEXT, VIDEO, AUDIO, AND PHOTOGRAPHY IN THE AREA OF NON-PROFIT AND CHARITABLE ACTIVITY; DOWNLOADABLE PODCASTS IN THE FIELD OF CONTENT IN THE AREA OF NON-PROFIT AND CHARITABLE ACTIVITY; DOWNLOADABLE WEBCASTS IN THE FIELD OF CONTENT IN THE AREA OF NON-PROFIT AND CHARITABLE ACTIVITY; DOWNLOADABLE ELECTRONIC PUBLICATIONS IN THE NATURE OF WORKBOOKS, INSTRUCTIONAL BROCHURES AND, MAGAZINES IN THE FIELD OF CONTENT IN THE AREA OF NON-PROFIT AND CHARITABLE ACTIVITY; DOWNLOADABLE GRAPHICS FOR MOBILE PHONES ; DOWNLOADABLE FILMS AND TELEVISION PROGRAMS FEATURING CONTENT IN THE AREA OF NON-PROFIT AND CHARITABLE ACTIVITY PROVIDED VIA A VIDEO-ON-DEMAND SERVICE (U.S. CLS. 21, 23, 26, 36 AND 38).

CLASS 25—CLOTHING

FOR APPAREL, NAMELY, HEADWEAR, T-SHIRTS, SWEAT SHIRTS (U.S. CLS. 22 AND 39).

CLASS 35—ADVERTISING AND BUSINESS

FOR RETAIL STORE AND ON-LINE RETAIL STORE SERVICES FEATURING APPAREL, BOOKS AND PUBLICATIONS, BAGS AND LUGGAGE; PROMOTING PUBLIC AWARENESS OF NON-PROFIT, CHARITABLE, ENVIRONMENTAL AND HUMANITARIAN EFFORTS BY TEXT, VIDEO, AUDIO AND PHOTOGRAPHY ON A WEBSITE; ARRANGING AND CONDUCTING TRADE SHOWS AND TRADE FAIRS IN THE FIELD OF NON-PROFIT ACTIVITY (U.S. CLS. 100, 101 AND 102).

CLASS 38—COMMUNICATION

FOR TELEVISION BROADCASTING; CABLE TELEVISION BROADCASTING; INTERNET BROADCASTING SERVICES (U.S. CLS. 100, 101 AND 104).

CLASS 41—EDUCATION AND ENTERTAINMENT

FOR EDUCATIONAL SERVICES, NAMELY, HOSTING EDUCATIONAL SEMINARS IN THE FIELD OF NON-PROFIT, CHARITABLE, ENVIRONMENTAL AND HUMANITARIAN EFFORTS; AWARDS PROGRAMS FOR CORPORATIONS AND INDIVIDUALS WHO HAVE MADE A SIGNIFICANT CHARITABLE CONTRIBUTION; ORGANIZING PUBLIC FESTIVALS FEATURING A VARIETY OF ACTIVITIES, NAMELY, HERITAGE MARKETS, ETHNIC DANCES AND THE LIKE; ORGANIZATION OF EXHIBITIONS FOR CULTURAL AND EDUCATIONAL PURPOSES (U.S. CLS. 100, 101 AND 107).

SUSAN LESLIE DUBOIS, EXAMINING ATTORNEY

SN 85-253,176. WCI COMMUNITIES, LLC, BONITA SPRINGS, FL. FILED 2-28-2011.

MY WCI

THE MARK CONSISTS OF STANDARD CHARACTERS WITHOUT CLAIM TO ANY PARTICULAR FONT, STYLE, SIZE, OR COLOR.

OWNER OF U.S. REG. NOS. 2,561,231, 2,684,095 AND OTHERS.

CLASS 36—INSURANCE AND FINANCIAL

FOR REAL ESTATE SERVICES, NAMELY, PROVIDING INFORMATION ONLINE REGARDING HOME WARRANTY (U.S. CLS. 100, 101 AND 102).

CLASS 42—SCIENTIFIC AND COMPUTER SERVICES

FOR PROVIDING AN ONLINE, NON-DOWNLOADABLE SOFTWARE APPLICATION FOR HANDHELD COMPUTERS FEATURING LINKS TO INFORMATIONAL VIDEOS AND WEBSITES WITH INFORMATION IN RELATION TO NEW HOME CONSTRUCTION, TITLE, MORTGAGE AND INSURANCE, AND COMMUNITY AMENITIES; AND COMPUTER SERVICES, NAMELY, REMOTE MANAGEMENT OF ELECTRONIC HOME LIGHTING, HEATING, COOLING, AND SECURITY SYSTEMS (U.S. CLS. 100 AND 101).

BARBARA BROWN, EXAMINING ATTORNEY

SN 85-253,495. CAN MANUFACTURERS INSTITUTE, INC., WASHINGTON, DC. FILED 2-28-2011.

THE GREAT AMERICAN CAN ROUNDUP

THE MARK CONSISTS OF STANDARD CHARACTERS WITHOUT CLAIM TO ANY PARTICULAR FONT, STYLE, SIZE, OR COLOR.

NO CLAIM IS MADE TO THE EXCLUSIVE RIGHT TO USE "CAN", APART FROM THE MARK AS SHOWN.

CLASS 35—ADVERTISING AND BUSINESS

FOR PROMOTING COMMUNITY RECYCLING SUSTAINABILITY BY SPONSORING RECYCLING EVENTS; PROMOTING PUBLIC AWARENESS OF THE NEED TO RECYCLE AND THE BENEFITS OF RECYCLING; ASSOCIATION SERVICES, NAMELY, PROMOTING THE INTERESTS OF CAN MANUFACTURERS AND THEIR SUPPLIERS; PROVIDING CONSUMER PRODUCT INFORMATION REGARDING THE SUSTAINABILITY OF STEEL AND ALUMINUM AND PRODUCTS MADE OF THESE MATERIALS (U.S. CLS. 100, 101 AND 102).

CLASS 40—MATERIAL TREATMENT

FOR PROVIDING INFORMATION ABOUT THE IMPORTANCE OF RECYCLING; PROVIDING INFORMATION ABOUT STEEL AND ALUMINUM CAN RECYCLING AND THE SUSTAINABILITY BENEFITS OF RECYCLING; PROVIDING MANUFACTURING INFORMATION REGARDING THE SUSTAINABILITY OF STEEL AND ALUMINUM AND PRODUCTS MADE OF THESE MATERIALS (U.S. CLS. 100, 103 AND 106).

RUDY R. SINGLETON, EXAMINING ATTORNEY

SN 85-255,853. GRABOVOI, GRIGORI PETROVICH, MOSCOW, RUSSIAN FED., FILED 3-2-2011.

SN 85-258,158. SMARTRAY GMBH, WOLFRATSHAUSEN, FED REP GERMANY, FILED 3-4-2011.

Grigori Grabovoi



THE MARK CONSISTS OF STANDARD CHARACTERS WITHOUT CLAIM TO ANY PARTICULAR FONT, STYLE, SIZE, OR COLOR.

THE NAME(S), PORTRAIT(S), AND/OR SIGNATURE(S) SHOWN IN THE MARK IDENTIFIES "GRIGORI GRABOVOI", WHOSE CONSENT(S) TO REGISTER IS MADE OF RECORD.

CLASS 9—ELECTRICAL AND SCIENTIFIC APPARATUS

FOR DOWNLOADABLE ELECTRONIC PUBLICATIONS IN THE NATURE OF BOOKS AND NEWSLETTERS IN THE FIELD OF HOLISTIC MEDICINE, MENTAL AND SPIRITUAL TECHNOLOGIES; DVDS AND EDUCATIONAL COMPUTER SOFTWARE FEATURING INSTRUCTION IN THE FIELD OF CONCENTRATION EXERCISES, HOLISTIC MEDICINE AND MENTAL AND SPIRITUAL TECHNOLOGIES (U.S. CLS. 21, 23, 26, 36 AND 38).

CLASS 16—PAPER GOODS AND PRINTED MATTER

FOR PRINTED MATTER, NAMELY, BOOKS, MANUALS, CURRICULUM, NEWSLETTERS, AND BROCHURES IN THE FIELD OF CONCENTRATION EXERCISES, HOLISTIC MEDICINE AND MENTAL AND SPIRITUAL TECHNOLOGIES; PRINTED INSTRUCTIONAL, EDUCATIONAL, AND TEACHING MATERIALS IN THE FIELD OF CONCENTRATION EXERCISES, HOLISTIC MEDICINE AND MENTAL AND SPIRITUAL TECHNOLOGY (U.S. CLS. 2, 5, 22, 23, 29, 37, 38 AND 50).

CLASS 41—EDUCATION AND ENTERTAINMENT

FOR PROFESSIONAL COACHING SERVICES IN THE FIELD OF HOLISTIC MEDICINE, MENTAL AND SPIRITUAL TECHNOLOGIES; EDUCATION SERVICES, NAMELY, PROVIDING EDUCATIONAL WORKSHOPS AT ACADEMIES, AND PROVIDING CLASSES AND APPRENTICESHIPS, ALL IN THE FIELD OF HOLISTIC MEDICINE, MENTAL AND SPIRITUAL TECHNOLOGIES; EDUCATION IN THE FIELDS OF HOLISTIC MEDICINE, MENTAL AND SPIRITUAL TECHNOLOGIES RENDERED THROUGH CORRESPONDENCE COURSES; ORGANIZING ARRANGING AND CONDUCTING LECTURES, LIVE EDUCATION SEMINARS AND COACHING IN THE FIELD OF HOLISTIC MEDICINE; CONDUCTING WORKSHOPS AND SEMINARS IN THE FIELD OF HOLISTIC MEDICINE, MENTAL AND SPIRITUAL TECHNOLOGIES; PUBLISHING OF ELECTRONIC PUBLICATIONS (U.S. CLS. 100, 101 AND 107).
VERNA BETH RIRIE, EXAMINING ATTORNEY

OWNER OF ERPN CMNTY TM OFC REG. NO. 009268012, DATED 12-8-2010, EXPIRES 7-23-2020.

THE MARK CONSISTS OF SIX CHECK MARKS THAT BEGIN AT THE LEFT AND END AT A HIGHER POINT ON THE RIGHT THAT ALL OVERLAP IN EQUAL DISTANCE APART WITH EACH CHECK MARK WIDER THAN THE LAST.

CLASS 9—ELECTRICAL AND SCIENTIFIC APPARATUS

FOR SCIENTIFIC, NAUTICAL, SURVEYING, PHOTOGRAPHIC, CINEMATOGRAPHIC, OPTICAL, MEASURING, SIGNALING, CHECKING, SUPERVISION, LIFESAVING AND TEACHING APPARATUS AND INSTRUMENTS, NAMELY, OPTICAL SENSORS, CAMERAS, OPTICAL SCANNERS, TRACKING EQUIPMENT FOR TRACKING, INSPECTION, AND MONITORING OF CONTOURS AND SURFACES OF MATERIALS, QUALITY SURVEYING AND CONTROL EQUIPMENT FOR TRACKING, INSPECTION AND MONITORING OF CONTOURS AND SURFACES OF MATERIALS, SENSORS FOR CONTROL AND SURVEYING OF INDUSTRIAL MANUFACTURING PROCESSES, CONTACTLESS MEASUREMENT EQUIPMENT FOR MEASURING TRACKING, INSPECTION AND MONITORING OF CONTOURS AND SURFACES OF MATERIALS; PROCESSING HARDWARE FOR SCIENTIFIC, NAUTICAL, SURVEYING, PHOTOGRAPHIC, CINEMATOGRAPHIC, OPTICAL, MEASURING, SIGNALING, CHECKING, SUPERVISION, LIFESAVING AND TEACHING APPARATUS AND INSTRUMENTS FOR TRACKING, INSPECTION, AND MONITORING CONTOURS AND SURFACES OF MATERIALS; PROCESSING SOFTWARE FOR TRACKING, INSPECTION, AND MONITORING CONTOURS AND SURFACES OF MATERIALS FOR SCIENTIFIC, NAUTICAL, SURVEYING, PHOTOGRAPHIC, CINEMATOGRAPHIC, OPTICAL, MEASURING, SIGNALING, CHECKING, SUPERVISION, LIFESAVING AND TEACHING APPARATUS AND INSTRUMENTS; WEIGHING APPARATUS AND INSTRUMENTS; APPARATUS FOR RECORDING, TRANSMISSION OR REPRODUCTION OF SOUND OR IMAGES (U.S. CLS. 21, 23, 26, 36 AND 38).

CLASS 42—SCIENTIFIC AND COMPUTER SERVICES

FOR SCIENTIFIC AND TECHNOLOGICAL SERVICES, NAMELY, RESEARCH AND DESIGN IN THE FIELD OF OPTICAL SENSORS, CAMERAS, OPTICAL SCANNERS, TRACKING SYSTEMS, QUALITY SURVEYING AND CONTROL SYSTEMS, SENSORS AND SYSTEMS FOR CONTROL AND SURVEYING OF INDUSTRIAL MANUFACTURING PROCESSES, SYSTEMS FOR CONTACTLESS MEASUREMENT, PROCESSING HARDWARE AND SOFTWARE FOR THE AFOREMENTIONED GOODS; DESIGN AND DEVELOPMENT OF COMPUTER HARDWARE AND SOFTWARE (U.S. CLS. 100 AND 101).
KRISTINA MORRIS, EXAMINING ATTORNEY

SN 85-260,705. EQUIFAX INC., ATLANTA, GA. FILED 3-8-2011.

SMALL BUSINESS MARKET NAVIGATOR

THE MARK CONSISTS OF STANDARD CHARACTERS WITHOUT CLAIM TO ANY PARTICULAR FONT, STYLE, SIZE, OR COLOR.

NO CLAIM IS MADE TO THE EXCLUSIVE RIGHT TO USE "SMALL BUSINESS MARKET", APART FROM THE MARK AS SHOWN.

CLASS 35—ADVERTISING AND BUSINESS

FOR COMMERCIAL INFORMATION AGENCY SERVICES FOR BUSINESSES IN THE AREAS OF MARKETING AND CREDIT INFORMATION; MARKETING SERVICES, NAMELY, MARKET RESEARCH, MARKET DATA ANALYSIS, CONDUCTING AND ANALYZING MARKET SURVEY RESEARCH (U.S. CLS. 100, 101 AND 102).

CLASS 36—INSURANCE AND FINANCIAL

FOR FINANCIAL RISK MANAGEMENT CONSULTATION (U.S. CLS. 100, 101 AND 102).
DANIEL CAPSHAW, EXAMINING ATTORNEY

SN 85-261,871. CARL FREUDENBERG KG, D-69469 WEINHEIM, FED REP GERMANY, FILED 3-9-2011.

MICRO FRESH

THE MARK CONSISTS OF STANDARD CHARACTERS WITHOUT CLAIM TO ANY PARTICULAR FONT, STYLE, SIZE, OR COLOR.

OWNER OF FED REP GERMANY REG. NO. 302010068651, DATED 2-4-2011, EXPIRES 11-30-2021.

CLASS 7—MACHINERY

FOR FILTERS AS PARTS OF STATIONARY ENGINES AND HEAVY EQUIPMENT, NAMELY, AIR FILTERS AND FROM EXISTING SYSTEMS, COMPONENTS THEREOF AND THEIR ACCESSORIES (U.S. CLS. 13, 19, 21, 23, 31, 34 AND 35).

CLASS 11—ENVIRONMENTAL CONTROL APPARATUS

FOR FILTERS AS PARTS OF INDUSTRIAL PLANTS (U.S. CLS. 13, 21, 23, 31 AND 34).

CLASS 37—CONSTRUCTION AND REPAIR

FOR SERVICES IN THE FIELD OF FILTER TECHNOLOGY, NAMELY, INSTALLATION AND MAINTENANCE OF FILTRATION SYSTEMS AND PARTS OF FILTRATION SYSTEMS; MONITORING OF MAINTENANCE INTERVALS FOR FILTRATION SYSTEMS (U.S. CLS. 100, 103 AND 106).

CLASS 42—SCIENTIFIC AND COMPUTER SERVICES

FOR QUALITY EVALUATION OF FILTRATION SYSTEMS; TECHNICAL MONITORING OF FILTER INSTALLATIONS (U.S. CLS. 100 AND 101).
PAM WILLIS, EXAMINING ATTORNEY

SN 85-266,895. PATNI COMPUTER SYSTEMS LIMITED, ANDHERI (E), MUMBAI, INDIA, FILED 3-15-2011.

SPRINTEST

THE MARK CONSISTS OF STANDARD CHARACTERS WITHOUT CLAIM TO ANY PARTICULAR FONT, STYLE, SIZE, OR COLOR.

CLASS 9—ELECTRICAL AND SCIENTIFIC APPARATUS

FOR COMPUTER PROGRAMS FOR ANALYSIS AND TESTING OF COMPUTER SOFTWARE FOR UNIT, INTEGRATION, SYSTEM, AND ACCEPTANCE TESTING FOR SOFTWARE IN THE FIELDS OF BANKING, FINANCIAL SERVICES, INSURANCE, HEALTH CARE, MANUFACTURING, RETAIL, LOGISTICS, MEDIA, ENTERTAINMENT, COMMUNICATIONS, PRODUCT ENGINEERING AND INFORMATION TECHNOLOGY (U.S. CLS. 21, 23, 26, 36 AND 38).

CLASS 42—SCIENTIFIC AND COMPUTER SERVICES

FOR COMPUTER SERVICES, NAMELY, TESTING OF COMPUTER SOFTWARE FOR OTHERS, NAMELY, UNIT, INTEGRATION, SYSTEM, AND ACCEPTANCE TESTING FOR SOFTWARE IN THE FIELDS OF BANKING, FINANCIAL SERVICES, INSURANCE, HEALTH CARE, MANUFACTURING, RETAIL, LOGISTICS, MEDIA, ENTERTAINMENT, COMMUNICATIONS, PRODUCT ENGINEERING AND INFORMATION TECHNOLOGY (U.S. CLS. 100 AND 101).
ANN E. SAPPENFIELD, EXAMINING ATTORNEY

SN 85-270,301. RUITAI DIAMONDS LIMITED, KOWLOON, HONG KONG, FILED 3-18-2011.



THE MARK CONSISTS OF THE HIGHLY STYLIZED LETTERS "V" AND "K", COMPRISED OF A PAIR OF ABSTRACT TRIANGULAR SHAPES WITH A LOOP FORMED IN THE INSIDE OF EACH FORMED BY ONE SIDE, AND IN THE CENTER BETWEEN THE TWO DESIGNS, AN ABSTRACT DIAMOND SHAPE RISING FROM ONE OF THE TRIANGLES, WITH THREE LOOPS COMPRISING THE THREE TOP CORNERS OF THE DIAMOND.

CLASS 14—JEWELRY

FOR PRECIOUS METALS AND THEIR ALLOYS AND GOODS IN PRECIOUS METALS OR COATED THEREWITH, NOT INCLUDED IN OTHER CLASSES, NAMELY, RING, EARRINGS, PENDANT, BRACELET, BANGLE, CLASPS, NECKLACE, BROOCH, CHARMS, CUFFLINK, CROWNS, TIARAS, MINIATURE CROWNS AND TIARAS; JEWELLERY, PRECIOUS STONES; HOROLOGICAL AND CHRONOMETRIC INSTRUMENTS (U.S. CLS. 2, 27, 28 AND 50).

CLASS 16—PAPER GOODS AND PRINTED MATTER

FOR STATIONERY; PAPER MATERIALS FOR PACKAGING, NAMELY, CARDBOARD BOXES, POSTERS, PAMPHLETS FEATURING RING, EARRINGS, PENDANT, BRACELET, BANGLE, CLASPS, NECKLACE, BROOCH, CHARMS, CUFFLINK, CROWNS, TIARAS, MINIATURE CROWNS AND TIARAS, HOROLOGICAL AND CHRONOMETRIC INSTRUMENTS, POSTCARDS, CATALOGUES, LABELS NOT OF TEXTILE; PLASTIC MATERIALS FOR PACKAGING, NOT INCLUDED IN OTHER CLASS, NAMELY, ADHESIVE TAPES FOR STATIONERY PURPOSES, BAGS; PAPER, ADHESIVES FOR STATIONERY OR HOUSEHOLD PURPOSES; PAPER BAGS FOR WRAPPING AND PACKAGING PURPOSES; PAPER BOXES FOR PACKAGING (U.S. CLS. 2, 5, 22, 23, 29, 37, 38 AND 50).

CLASS 35—ADVERTISING AND BUSINESS

FOR RETAIL AND WHOLESALE STORE SERVICES FEATURING PRECIOUS METALS AND THEIR ALLOYS AND GOODS IN PRECIOUS METALS OR COATED THEREWITH, JEWELLERY, PRECIOUS STONES, HOROLOGICAL AND CHRONOMETRIC INSTRUMENTS; ADVERTISING; BUSINESS MANAGEMENT; BUSINESS ADMINISTRATION; OFFICE FUNCTIONS; SHOP WINDOW DRESSING; PUBLICATION OF PUBLICITY TEXT; DISTRIBUTION OF SAMPLES; DEMONSTRATION OF GOODS, NAMELY, PRODUCT DEMONSTRATIONS FEATURING RINGS, EARRINGS, PENDANT, BRACELET, BANGLE, CLASPS, NECKLACE, BROOCH, CHARMS, CUFFLINK, CROWNS, TIARAS, MINIATURE CROWNS AND TIARAS; ORGANIZATION OF TRADE FAIRS FOR COMMERCIAL OR ADVERTISING PURPOSES; EXPORT-IMPORT AGENCIES SERVICES FOR GOODS IN PRECIOUS METALS AND THEIR ALLOYS AND GOODS IN PRECIOUS METALS OR COATED THEREWITH, JEWELLERY, PRECIOUS STONES, HOROLOGICAL AND CHRONOMETRIC INSTRUMENTS (U.S. CLS. 100, 101 AND 102).

EUGENIA MARTIN, EXAMINING ATTORNEY

SN 85-270,449. PIZZA HUT, INC., PLANO, TX. FILED 3-18-2011.

SERVING PIZZAS. SAVING TREES.

THE MARK CONSISTS OF STANDARD CHARACTERS WITHOUT CLAIM TO ANY PARTICULAR FONT, STYLE, SIZE, OR COLOR.

NO CLAIM IS MADE TO THE EXCLUSIVE RIGHT TO USE "SERVING PIZZAS", APART FROM THE MARK AS SHOWN.

CLASS 16—PAPER GOODS AND PRINTED MATTER

FOR BOXES, CARTONS, STORAGE CONTAINERS, AND PACKAGING CONTAINERS MADE OF PAPER OR CARDBOARD (U.S. CLS. 2, 5, 22, 23, 29, 37, 38 AND 50).

CLASS 29—MEATS AND PROCESSED FOODS

FOR COOKED AND PREPARED CHICKEN (U.S. CL. 46).

CLASS 30—STAPLE FOODS

FOR PIZZA; PREPARED PASTA ENTREES (U.S. CL. 46).

CLASS 39—TRANSPORTATION AND STORAGE

FOR PIZZA, COOKED PASTA AND COOKED CHICKEN DELIVERY SERVICES (U.S. CLS. 100 AND 105).

CLASS 43—HOTEL AND RESTAURANT SERVICES

FOR RESTAURANT SERVICES (U.S. CLS. 100 AND 101).

MICHAEL KEATING, EXAMINING ATTORNEY

SN 85-271,276. CADAC (PTY) LTD, CONSTANTIA KLOOF, SOUTH AFRICA, FILED 3-18-2011.

CARRI CHEF DELUXE

THE MARK CONSISTS OF STANDARD CHARACTERS WITHOUT CLAIM TO ANY PARTICULAR FONT, STYLE, SIZE, OR COLOR.

NO CLAIM IS MADE TO THE EXCLUSIVE RIGHT TO USE "DELUXE", APART FROM THE MARK AS SHOWN.

CLASS 11—ENVIRONMENTAL CONTROL APPARATUS

FOR BARBECUES; GAS BARBECUE COOKERS; GAS BARBECUES; BARBECUE GRILLS AND PARTS AND ACCESSORIES THEREFOR, NAMELY, COOKING DISHES IN THE NATURE OF CONVECTION PLATES, HOT PLATES AND COOKTOPS; BARBECUES, GAS BARBECUE COOKERS, GAS BARBECUES, BARBECUE GRILLS AND PARTS AND ACCESSORIES THEREFOR, NAMELY, COOKING DISHES IN THE NATURE OF CONVECTION PLATES, HOT PLATES AND COOKTOPS, ALL SOLD AS A UNIT (U.S. CLS. 13, 21, 23, 31 AND 34).
FIRST USE 5-0-2004; IN COMMERCE 5-0-2004.

CLASS 21—HOUSEWARES AND GLASS

FOR COOKING DISHES; BURNER PANS IN THE NATURE OF STOVE BURNER COVERS (U.S. CLS. 2, 13, 23, 29, 30, 33, 40 AND 50).
FIRST USE 5-0-2004; IN COMMERCE 5-0-2004.
HAI-LY LAM, EXAMINING ATTORNEY

SN 85-272,163. COMITÉ INTERNATIONAL OLYMPIQUE, 1007 LAUSANNE, SWITZERLAND, FILED 3-21-2011.

 RIO 2016

OWNER OF SWITZERLAND REG. NO. 564080, DATED 11-2-2007, EXPIRES 5-25-2017.

THE MARK CONSISTS OF FIVE INTERLOCKING RINGS FOLLOWED BY "RIO", WHICH IS FOLLOWED BY "2016".

CLASS 1—CHEMICALS

FOR CHEMICALS FOR USE IN INDUSTRY AND SCIENCE, NAMELY, CHEMICAL ADDITIVES FOR USE IN THE PHARMACEUTICAL INDUSTRY AND THE FOOD INDUSTRY; UNPROCESSED ARTIFICIAL RESINS FOR USE IN MANUFACTURING PLASTICS, UNPROCESSED PLASTICS; MANURES; FIRE EXTINGUISHING COMPOSITIONS; TEMPERING AND SOLDERING PREPARATIONS; CHEMICAL SUBSTANCES FOR PRESERVING FOODSTUFFS; ADHESIVES USED IN INDUSTRY FOR THE BINDING OF BOOKS, FOR THE MANUFACTURE OF SURGICAL BANDAGES, AND ADHESIVES USED IN CONSTRUCTION; SYNTHETIC RESINS; THERMOPLASTIC AND THERMOSETTING SYNTHETIC RESINS ORGANIC MOLDING COMPOSITIONS, FOR GENERAL USE IN THE INDUSTRIAL ARTS; CHEMICAL INTERMEDIATES; ORGANOSILICONE COMPOUNDS, NAMELY, POLYSILOXANES AND SILANES IN THE FORM OF RESINS; CHEMICAL ANTIFOAMING AGENTS; CHEMICAL CATALYSTS FOR PAINTS; CHEMICALS FOR DEVELOPING AND FIXING X-RAY FILMS AND OTHER CHEMICALS ASSOCIATED WITH THE DEVELOPMENT OF SAID FILMS; CHEMICAL PHOSPHORS; CHEMICAL SUBSTANCES FOR USE AS NUCLEAR FISSIONABLE MATERIAL; ADHESIVE SUBSTANCES USED IN INDUSTRY; SOLDERING FLUXES AND PREPARATIONS; THERMOPLASTIC AND THERMOSETTING ADHESIVES; CHEMICALS, BIOCHEMICALS AND REAGENTS FOR USE IN INDUSTRY, SCIENCE AND RESEARCH FOR NON-MEDICAL PURPOSES; CHEMICAL PREPARATIONS, TEST KITS AND REAGENTS FOR ANALYSIS OR DIAGNOSIS USED FOR SCIENTIFIC PURPOSES, NAMELY, CHEMICAL PREPARATIONS FOR CELL SEPARATION AND CULTURE, NUCLEIC ACID PURIFICATION, NUCLEOTIDES, FLUORESCENT NUCLEOTIDES, OLIGONUCLEOTIDES, PEPTIDES, PROTEINS, AMINO ACIDS, ORGANIC MOLECULES, AND MARKERS FOR DNA/RNA SYNTHESIS. SUBSTANCES FOR SCIENTIFIC OR MEDICAL RESEARCH USE, NAMELY, REAGENTS FOR LUMINESCENCE, REAGENTS FOR GENE EXPRESSION QUANTIFICATION, REAGENTS FOR USE WITH THE POLYMERASE CHAIN REACTION PROCESS, REAGENTS FOR USE WITH THE ROLLING CIRCLE AMPLIFICATION PROCESS, REAGENTS FOR DNA CLONING AND VECTORS, MODIFYING AND RESTRICTION ENZYMES, REAGENTS FOR LABELING, SEQUENCING AND FRAGMENT ANALYSIS OF NUCLEIC ACIDS, PROTEINS AND CUSTOM SYNTHESIS, REAGENTS FOR RECOMBINANT PROTEIN EXPRESSION PURIFICATION; CHROMATOGRAPHY CHEMICALS; SUBSTANCES FOR SCIENTIFIC OR MEDICAL RESEARCH USE, NAMELY, REAGENTS FOR ELECTROPHORESIS, BIOINFORMATICS, SPECTROPHOTOMETRY AND FLUOROMETRY; RADIOCHEMICALS FOR SCIENTIFIC RESEARCH USE; SUBSTANCES FOR SCIENTIFIC OR MEDICAL RESEARCH USE, NAMELY, REAGENTS FOR SCINTILLATING PROXIMITY ASSAYS, HIGH THROUGH PUT SCREENING ASSAYS FOR DRUG DEVELOPMENT, REAGENTS FOR HIGH RESOLUTION LASER FLUORESCENCE CONFOCAL MICROSCOPY; SPECIALTY CHEMICALS FOR USE IN INDUSTRY, SCIENCE AND RESEARCH; CHEMICAL PREPARATIONS AND ADDITIVES FOR USE IN THE MANUFACTURE OF PHARMACEUTICAL PRODUCTS, AND DIAGNOSTIC PREPARATIONS AND SUBSTANCES; CHEMICAL TEST REAGENTS, SALINE SOLUTION AND REAGENT-COATED PAPER ALL FOR SCIENTIFIC AND LABORATORY USE; FISSIONABLE CHEMICAL ELEMENTS FOR SCIENTIFIC RESEARCH USE; RADIOACTIVE ELEMENTS AND ISOTOPES FOR INDUSTRIAL, SCIENTIFIC AND RESEARCH PURPOSES; CHEMICALS AND CHEMICAL COMPOSITIONS FOR USE IN THE TREATMENT OF WATER SYSTEMS, WASTE WATER TREATMENT SYSTEMS, COOLING WATER SYSTEMS, BOILER WATER AND STEAM GENERATING SYSTEMS, BOILER CONDENSATE SYSTEMS, FLUID SEPARATION SYSTEMS, WATER CLARIFICATION AND DEWATERING IN AQUEOUS SYSTEMS, CONDITIONING SYSTEMS, GAS CLEANING SYSTEMS, INDUSTRIAL PROCESS SYSTEMS, FUELS AND FUEL PROCESSING SYSTEMS, HYDROCARBON AND GAS PROCESSING SYSTEMS, OIL AND GAS PROCESSING AND PETROCHEMICAL SYSTEMS, PULP AND PAPER-MAKING SYSTEMS, METAL AND PLASTIC COATING SYSTEMS, METAL PROCESSING SYSTEMS; CHEMICAL PRODUCTS, NAMELY, CHEMICAL GASOLINE ADDI-

TIVES, DISTILLATE CHEMICAL AND DETERGENT FUEL ADDITIVES AND PERFORMANCE ADDITIVES FOR FUELS USED IN TURBINE ENGINES; BAGS OF CHEMICALLY-TREATED WATER-ABSORBING GRANULAR MATERIALS FOR PLACEMENT INTO FUEL TANKS; TEST KIT CONSISTING OF REAGENTS USED FOR DETERMINING THE PRESENCE OF ALGAE AND ACTIVE ORGANIC ORGANISMS IN DIESEL FUEL; POLYMERIC CHEMICALS USED TO DISPERSE PARTICULATE MATTER IN STEAM GENERATING EQUIPMENT; CHEMICALS AND CHEMICAL COMPOSITIONS AS ANTIFOULANTS AND DEMULSIFIERS IN COKE-MAKING AND BY-PRODUCT OPERATIONS OF IRON AND STEEL INDUSTRIES; CHEMICALS, CATALYSTS, AND UNWORKED PLASTICS FOR USE AS FILTERING MATERIAL, ACID GAS ELIMINATING FILTERS, AND ZINC OXIDE WHISKER CRYSTALS FILTERS; UNPROCESSED PLASTICS, NONE OF THE ABOVE COVERING PHOTOGRAPHIC, CINEMATOGRAPHIC OR OPTICAL GOODS; CHEMICAL ETCHING FLUIDS FOR DISSOLVING UNWANTED MATERIALS, NAMELY, METALS, SEMICONDUCTOR MATERIAL AND GLASS (U.S. CLS. 1, 5, 6, 10, 26 AND 46).

CLASS 2—PAINTS

FOR PAINTS, VARNISHES, LACQUERS; COATINGS IN THE NATURE OF PRESERVATIVES AGAINST RUST AND AGAINST DETERIORATION OF WOOD; COLORANTS; MORDANTS DYES; RAW NATURAL RESINS; METALS IN FOIL AND POWDER FORM FOR PAINTERS, DECORATORS, PRINTERS AND ARTISTS; CORROSION INHIBITANTS IN THE NATURE OF A COATING FOR USE IN THE METAL FINISHING INDUSTRY, NAMELY, A FINAL AQUEOUS ACIDIC RINSE; CORROSION INHIBITANTS IN THE NATURE OF A COATING FOR USE IN COOLING WATER SYSTEMS; CORROSION INHIBITANTS IN THE NATURE OF A COATING, NAMELY, RESINOUS COATINGS FOR METAL AND MASONRY SURFACES; COATING MATERIALS, NAMELY, COATINGS IN THE NATURE OF FLUIDS FOR PROTECTION AGAINST CHEMICALS, WEATHER DAMAGES, SCRATCHES, PAINT CHIPPING (U.S. CLS. 6, 11 AND 16).

CLASS 3—COSMETICS AND CLEANING PREPARATIONS

FOR BLEACHING PREPARATIONS AND OTHER DETERGENT SUBSTANCES FOR LAUNDRY USE, NAMELY, LAUNDRY BLEACH, LAUNDRY BLUEING, LAUNDRY DETERGENT, LAUNDRY PRE-SOAK, LAUNDRY SIZING, LAUNDRY SOAP, LAUNDRY STARCH FOR LAUNDRY USE; GENERAL PURPOSE CLEANING, POLISHING, SCOURING AND ABRASIVE PREPARATIONS; SOAPS; PERFUMERY, ESSENTIAL OILS, COSMETICS, HAIR LOTIONS; DENTIFRICES; CLEANING PREPARATIONS CONTAINING CHEMICALS AND CHEMICAL COMPOSITIONS FOR USE IN CLEANING STEEL, ALUMINIUM, GALVANIZED AND MIXED METAL SURFACES FOR GENERAL INDUSTRIAL USE IN THE MANUFACTURE OF METAL PRODUCTS; CLEANING AGENTS CONTAINING CHEMICALS AND CHEMICAL COMPOSITIONS FOR USE IN INDUSTRY TO REMOVE CONTAMINANTS FROM INDUSTRIAL PROCESS SYSTEMS; PAINT STRIPPERS CONTAINING CHEMICALS AND CHEMICAL COMPOSITIONS TO REMOVE PAINT FROM EQUIPMENT SURFACES IN PAINT SPRAY BOOTH OPERATIONS (U.S. CLS. 1, 4, 6, 50, 51 AND 52).

CLASS 5—PHARMACEUTICALS

FOR PHARMACEUTICAL PREPARATIONS FOR USE IN TREATING RESPIRATORY DISORDERS AND MASCULOSKELETAL SYSTEM DISORDERS; SANITARY PREPARATIONS FOR MEDICAL PURPOSES; DIETETIC FOOD AND BEVERAGES ADAPTED FOR MEDICAL USE, FOOD FOR BABIES; MEDICAL PLASTERS AND DRESSINGS; MATERIAL FOR STOPPING TEETH, DENTAL WAX; ALL PURPOSE DISINFECTANTS; PREPARATIONS FOR DESTROYING VERMIN; FUNGICIDES, HERBICIDES; PHARMACEUTICAL DIAGNOSTIC PREPARATIONS FOR MEDICAL PURPOSES; PHARMACEUTICAL SUBSTANCES FOR MEDICAL PURPOSES, NAMELY, FOR USE IN TREATING RESPIRATORY

DISORDERS AND MASCULOSKELETAL SYSTEM DISORDERS; DIAGNOSTIC REAGENTS AND PREPARATIONS FOR MEDICAL PURPOSES; DIAGNOSTIC RADIOPHARMACEUTICAL PREPARATIONS FOR CLINICAL, MEDICAL, SCIENTIFIC AND RESEARCH USE; RADIOPHARMACEUTICAL SOURCES AND STANDARDS FOR USE IN NUCLEAR MEDICINE; RADIOACTIVE PHARMACEUTICAL PREPARATIONS AND NON-RADIOACTIVE REAGENTS FOR PRODUCING RADIOPHARMACEUTICALS FOR IN VIVO DIAGNOSTIC OR THERAPEUTIC USE; PRE-FILLED VIALS CONTAINING MEDICAL DIAGNOSTIC REAGENTS; PRE-FILLED CARTRIDGES CONTAINING CHEMICAL REAGENTS FOR MEDICAL USE (U.S. CLS. 6, 18, 44, 46, 51 AND 52).

CLASS 7—MACHINERY

FOR MACHINES AND MACHINE TOOLS FOR CUTTING AND FORMING OF MATERIALS; MOTORS AND ENGINES NOT FOR LAND VEHICLES FOR GENERATING POWER AND ELECTRICITY; MACHINE COUPLINGS AND TRANSMISSION COMPONENTS NOT FOR LAND VEHICLES, NAMELY, SHAFTS AND GEAR BOXES; AGRICULTURAL IMPLEMENTS OTHER THAN HAND OPERATED IMPLEMENTS, NAMELY, INCORPORATORS AND SEED DRILLS; INCUBATORS FOR EGGS; APPARATUS, EQUIPMENT AND INSTRUMENTS FOR THE GENERATION OF POWER, NAMELY, ELECTRIC GENERATORS AND WIND POWERED ELECTRICITY GENERATORS; TURBINES; TURBINES FOR POWER GENERATION; WIND TURBINES FOR POWER GENERATION; WIND TURBINES IN ASSOCIATION WITH WIND FARMS, TURBINE GENERATING INSTALLATIONS, NAMELY, ELECTRIC POWER GENERATING INSTALLATIONS; ENGINES FOR THE GENERATION OF ELECTRICITY; AND PARTS AND FITTINGS FOR ALL THE AFORESAID; SOLAR-POWERED ELECTRICITY GENERATORS; DYNAMO ELECTRIC MACHINES, ELECTRIC MOTORS NOT FOR LAND VEHICLES, STEAM TURBINES, GAS TURBINES AND PARTS THEREOF, ELECTRIC GENERATORS AND THEIR PARTS, AIRCRAFT ENGINES, COMPRESSORS, NAMELY, AIR COMPRESSORS; WASHING MACHINES FOR CLOTHES, DISHWASHERS, GARBAGE DISPOSERS AND COMPACTORS; PUMPS, NAMELY, CENTRIFUGAL PUMPS, DIAPHRAGM PUMPS, BELLOW PUMPS AND ELECTRIC PROCESS AND TRANSFER PUMPS; MACHINE PARTS, NAMELY, FLUID SEPARATION CARTRIDGES AND PARTS THEREFORE, IN THE NATURE OF SEMI-PERMEABLE MEMBRANES; FILTER CARTRIDGES FOR VARIOUS INDUSTRIAL MACHINES FOR FILTRATION APPLICATIONS INCLUDING THE FILTRATION OF COATING SOLUTIONS FOR THE MANUFACTURE OF MAGNETIC TAPE AND THE FILTRATION OF PETROCHEMICALS, PORTABLE WATER, BEER IN THE BREWING INDUSTRY, AND OTHER SPECIALTY CHEMICALS; MACHINES FOR THE FEEDING AND APPLICATION OF CHEMICALS FOR INDUSTRIAL USE; AXIAL AND CENTRIFUGAL COMPRESSORS; RECIPROCATING COMPRESSORS; SCREW AND VANE COMPRESSORS; ROTARY, VACUUM, ELECTRIC, SUBMERSIBLE AND CENTRIFUGAL PUMPS; TURBOEXPANDERS, NAMELY, AIR AND ELECTRIC COMPRESSORS; CNG (COMPRESSED NATURAL GAS) REFUELING MACHINES FOR LAND VEHICLES AND INDUSTRIAL EQUIPMENT AND ACCESSORIES AND PARTS FOR ALL THE FOREGOING NAMELY, PUMPS, VALVES, FUEL FILTERS, FILTER CASINGS, DISTRIBUTOR ROTORS, BLADES, BEARINGS AND MECHANICAL SEALS; STEAM CONDENSERS; BOAT ENGINES; TURBOCHARGERS FOR ENGINES; FUEL INJECTORS; WELDING MACHINES, INDUSTRIAL ROBOTS, MACHINES FOR INSERTING ELECTRONIC COMPONENTS, DRY ETCHING MACHINERY, MICRO ELECTRIC-DISCHARGE MACHINES, OPTICAL DISC PRODUCTION MACHINES, PRECISION JOINING MACHINES, PROCESSING MACHINES FOR PRINTED WIRED BOARDS AND WELDING WIRE, PARTS MOUNTING MACHINES, SOLDERING MACHINES, SCREW FASTENING MACHINES, ELECTRIC POWER TOOLS, NAMELY, DRILLS, SAWS, STONE CUTTERS, TILE CUTTERS, POLISHERS, SOLDERING CHISELS, SANDERS, BLOWERS, ROTARY HAMMERS, GRINDERS, SCREW DRIVERS, WRENCHES, SHEARS; ELECTRIC MOTORS FOR MACHINES, ELECTRIC GENERATORS; ELEVATORS; LAUNDRY CENTERS, NAMELY, A CLOTHES

WASHER COMBINED WITH A CLOTHES DRYER; ELECTRIC CLOTHES WASHING MACHINES, ELECTRIC DISH WASHERS; ELECTRIC COMPRESSORS; PUMPS, NAMELY, ELECTRIC PUMPS; MIXING, CUTTING AND CHOPPING MACHINES, ELECTRIC FOOD BLENDING MACHINES, ELECTRIC JUICE EXTRACTORS, ELECTRIC FOOD PROCESSORS, ELECTRIC MEAT GRINDERS, ELECTRIC CAN OPENERS, ELECTRIC KNIFE SHARPENERS, ELECTRIC COFFEE MILLS, ELECTRIC ICE CRUSHERS, ELECTRIC WASTE PROCESSORS; POWER-OPERATED GARDEN TOOLS, NAMELY, HEDGE TRIMMERS, SHREDDERS, CHIPPERS, CULTIVATORS, LEAF BLOWERS, GRASS SHEARS; ELECTRIC LAWN MOWERS, POWER-OPERATED GARDEN SPRAYERS FOR DISINFECTANTS AND INSECTICIDES; ELECTRIC APPLIANCES FOR CLEANING, NAMELY, ELECTRIC VACUUM CLEANERS, ELECTRIC FLOOR POLISHERS; ELECTRIC WINDOW CLEANERS; ELECTRICITY GENERATORS FOR HOME USE, ARC, GAS AND PLASMA METAL CUTTING MACHINES; ELECTRIC FOOD BLENDERS, ELECTRIC JUICERS, ELECTRIC MIXERS, ELECTRIC FOOD PROCESSOR, ELECTRIC MEAT GRINDERS, ELECTRIC CAN OPENERS, ELECTRIC KNIFE SHARPENERS; FOOD WASTE DISPOSALS FOR KITCHENS (U.S. CLS. 13, 19, 21, 23, 31, 34 AND 35).

CLASS 9—ELECTRICAL AND SCIENTIFIC APPARATUS

FOR BLANK MAGNETIC DATA CARRIERS, BLANK RECORDING DISCS, NAMELY, COMPACT DISCS; CASH REGISTERS, CALCULATING MACHINES, DATA PROCESSING EQUIPMENT AND COMPUTERS; FIRE-EXTINGUISHING APPARATUS; PROTECTIVE HELMETS FOR SPORTS; GLASSES, SUNGLASSES, SPORTS GLASSES, NAMELY, SPORTS GOGGLES FOR USE IN SKIING, RACQUETBALL, SWIMMING; COMPUTER SOFTWARE FOR INDIVIDUAL AND MULTI-PLAYER NETWORK GAMES AND INTERACTIVE EVOLUTIVE SCENARIO GAMES; FUEL PUMPS FOR SERVICE STATIONS FOR FUELING AIRPLANE ENGINES; FUEL DISTRIBUTION EQUIPMENT, NAMELY, METERED FUEL PUMPS, ELECTRICAL FUEL LEVEL GAUGES, CONTROL VALVES FOR REGULATING THE FLOW OF GASES AND FUEL LINES; AUTOMATED FUEL STATION MANAGEMENT SYSTEMS, COMPRISED OF COMPUTER OPERATING SOFTWARE, METERED FUEL PUMPS, RATE CONTROL PANELS, FUEL LINES AND DISPENSING NOZZLES FOR FUELING LAND AND MARINE VEHICLES AND MARINE VEHICLES AND AIRCRAFT; GAS METERS; AUTOMATED RAILWAY TRACK SWITCH MACHINES; GLOBAL POSITION SYSTEM (GPS) BASED TRACKING AND MONITORING SYSTEMS FOR THE RAILROAD AND TRANSIT INDUSTRIES; ELECTRICAL DEVICES AND ELECTRICAL POWER DISTRIBUTION PRODUCTS, NAMELY, CAPACITORS, CIRCUIT BREAKERS, CIRCUIT BREAKER LOAD CENTERS, CIRCUIT CLOSERS, CIRCUIT INTERRUPTERS, COMMUTATORS, CONTACTORS, CURRENT RECTIFIERS, CURRENT LIMITERS, ELECTRIC CONTACTS, ELECTRIC COLLECTORS, ELECTRIC CONDUCTORS, ELECTRIC CONNECTORS, ELECTRIC CONTROLLERS, ELECTRIC INDUCTORS, ELECTRIC POWER SUPPLIES, ELECTRICITY DISTRIBUTION BOARDS AND BOXES, ELECTRICITY DISTRIBUTION CONSOLES, ELECTRICITY SWITCHBOARDS AND SWITCHBOXES; COMPUTER SOFTWARE FOR TROUBLESHOOTING AND MAINTAINING PROGRAMMABLE CONTROLLERS, FOR ANALYZING BLOOD VESSELS INCLUDING CARDIAC VESSELS WHICH ALSO PROVIDES CALCULATION FUNCTIONS WITH RESPECT TO BLOOD VESSELS, FOR USE WITH MEDICAL PATIENT MONITORING EQUIPMENT, FOR RECEIVING, PROCESSING, TRANSMITTING AND DISPLAYING DATA, FOR USE IN DEVELOPING PERSONALIZED ASSET ALLOCATION PROGRAMS, FOR USE ON-LINE TO ENABLE OFFICE EQUIPMENT DEALERS TO SUBMIT APPLICATIONS, MANAGE PORTFOLIOS AND COMMUNICATE WITH THE COMPANY, FOR USE IN ACCESSING MORTGAGE AND INSURANCE INFORMATION, FOR COLLECTING DATA INVOLVING VITAL MEDICAL SIGNS, FOR USE WITH ELECTRICAL POWER SYSTEMS ANALYSES AND INSTRUCTIONAL MANUAL SOLD AS A UNIT THEREWITH, FOR USE BY EMPLOYEES FOR FINANCIAL INSTITUTIONS FOR DETERMINING FINANCIAL INVESTMENTS FOR CLIENTS AND IN PROCESSING THE

SALE OF THE IDENTIFIED INVESTMENTS, FOR OBTAINING INFORMATION ON THE FLOOD-HAZARD STATUS OF REAL PROPERTY, FOR THE DEVELOPMENT OF GRAPHICAL USER INTERFACES AND DATA VISUALIZATION, FOR USE TO CALCULATE MORTGAGE PAYMENTS, FOR REGULATING AND MANAGING VEHICLE FLEET MAINTENANCE SERVICES, FOR USE IN CONNECTION WITH ACCESSING AND UTILIZING COMMERCIAL COMPUTER SERVICES, FOR USE BY CUSTOMERS TO OBTAIN LEASE PORTFOLIO INFORMATION, FOR A RADIOLOGY INFORMATION SYSTEM FOR USE BY RADIOLOGISTS AND RADIOLOGY DEPARTMENT IN THE DATABASE MANAGEMENT OF EMPLOYEE AND PATIENT INFORMATION, FOR PATIENT MONITORING AND ARCHIVAL PURPOSES, INSTALLED ON AND USED IN CONNECTION WITH PCS AND MEDICAL MONITORING EQUIPMENT, FOR GRAPHICAL USER INTERFACE, FOR USE IN SENDING ENCRYPTED AND COMPRESSED DATA OVER PAGING CARRIER SYSTEMS, FOR PROVIDING ACCESS TO WEBSITES WHERE BUYERS AND SELLERS CAN CONDUCT BUSINESS ELECTRONICALLY, AND FOR UNDERGROUND NAVIGATION, NAMELY, FOR NAVIGATION OF DOWN HOLE PROBE ASSEMBLY FOR OIL DRILLING AND DRILLING ASSEMBLIES FOR ROUTING UNDERGROUND UTILITIES; ELECTRICAL GOODS, ELECTRICAL POWER GENERATION AND DISTRIBUTION PRODUCTS AND ELECTRICAL VOLTAGE AND OVERVOLTAGE SURGE PRODUCTS, NAMELY, ARRESTERS, BUSWAYS, CAPACITORS, LIGHTING CONTACTORS, CONTROLLERS AND INPUT/OUTPUT DEVICES IN THE NATURE OF KEYBOARDS AND MONITORS, FUSES, LIGHTING CONTROLLERS, SWITCH BOXES, LEDS, NAMELY, LIGHT EMITTING DIODES, VOLTAGE REGULATORS FOR ELECTRIC POWER, VOLTAGE SURGE PROTECTORS, VOLTAGE SURGE SUPPRESSORS, VOLTMETERS, ELECTRICAL CIRCUIT BOARDS, RELAYS AND TIMERS, SOLENOIDS AND LIMIT SWITCHES, FULL-VOLTAGE MANUAL STARTERS, REDUCED VOLTAGE STARTERS, ELECTRICAL SWITCHES AND DISCONNECTS, CIRCUIT BOARD TERMINAL BLOCKS AND PUMPING PANELS, CIRCUIT BREAKERS AND DISCONNECTS, TRANSFORMERS, ELECTRICAL LIGHTING AND POWER CIRCUIT BOARDS, ELECTRICAL WIRES, CABLES, CORDS, AND CONDUCTORS, ELECTRICAL WIRING, LIGHTNING ARRESTERS, ELECTRICITY METERS, POWER METERS, GROUNDING RESISTORS, HUMIDITY AND TEMPERATURE SENSORS; BUILDING AND WOOD SENSORS, SPECIFICALLY SOUND WAVE AND VIBRATION SENSORS; INDUSTRIAL CALIBRATION SENSORS, SPECIFICALLY, PROXIMITY SENSORS; PUSH BUTTONS, MOTOR CONTROL CENTERS COMPRISED PRIMARILY OF PHYSICAL GROUPINGS OF COMBINATION STARTERS IN ONE ASSEMBLY; ELECTRICAL RESISTANCE HEATING WIRES AND ELECTRICAL CONTROLLERS THEREFOR AND VOLTAGE REGULATORS; SOFTWARE AND SOFTWARE PROGRAMS FOR DATA COLLECTION, DATA MANAGEMENT AND DATA ANALYSIS FOR USE IN INDUSTRIAL, RESEARCH, AND MEDICAL USE; APPARATUS FOR ELECTROPHORESIS NOT FOR MEDICAL USE; CHROMATOGRAPHY COLUMNS AND PUMPS; APPARATUS FOR BIOINFORMATICS SYSTEMS, NAMELY, COMPUTER HARDWARE AND SOFTWARE FOR PROCESSING BIOLOGICAL INFORMATION; APPARATUS FOR SCINTILLATION, NAMELY, SCINTILLATION COUNTER TO MEASURE BETA-EMITTING NUCLIDES; IMAGING APPARATUS FOR RADIOACTIVE AND LUMINESCENT EMISSIONS, NAMELY, CAMERAS AND SCANNERS; SYNTHESIS AND PURIFICATION INTEGRATED SYSTEMS, NAMELY, CHROMATOGRAPHY COLUMNS, CARTRIDGES, FRACTION COLLECTORS, MIXERS, MONITORS, PUMPS, RECORDERS AND ANALYSIS SOFTWARE; APPARATUS FOR MICROARRAYS, NAMELY, PROBES, SLIDES, BUFFERS, BACTERIAL CONTROLS, RACKS AND TRAYS; LASER BASED OPTICAL APPARATUS FOR DIGITAL IMAGING NOT FOR MEDICAL USE; LABORATORY ARTICLES, NAMELY, MICROARRAY SLIDES; LABORATORY GLASSWARE, VIALS AND MICROVIALS AND MICROTITRE PLATES; COMPUTER SOFTWARE FOR HOSPITAL OPERATING ROOM MANAGEMENT; COMPUTER SOFTWARE FOR CRITICAL CARE INFORMATION MANAGEMENT; INDUSTRIAL PROCESS CONTROL SOFTWARE; COMPUTER SOFTWARE PROGRAMS AND PROGRAM MANUALS SOLD AS A UNIT FOR USE IN FACTORY MANAGEMENT; GRAPHICAL USER INTERFACE

BASED COMPUTER PROGRAMS FOR CONTROLLING MACHINES IN INDUSTRIAL AUTOMATION APPLICATIONS; SOFTWARE FOR CREATING GRAPHICS DISPLAYS AND EDITING DYNAMIC DATA INTERFACES FOR REAL TIME GRAPHICS APPLICATIONS FOR INDUSTRIAL AND BUSINESS APPLICATIONS; COMMUNICATIONS SOFTWARE FOR CONNECTING COMPUTER NETWORK USERS; INDUSTRIAL PROCESS SOFTWARE FOR PLASTIC INJECTION MOLDING; SOFTWARE FOR CONTROL, MONITORING, SIMULATION, COMMUNICATIONS, DATA LOGGING AND COLLECTION, AND FACTORY AUTOMATION; SOFTWARE TO INTEGRATE MANUFACTURING MACHINE OPERATIONS, CONTROL PROCESSES, PROVIDE DATA FOR VISUALIZATION, TRACK PROBLEMS AND GENERATE PRODUCTION REPORTS; PACKAGED SOFTWARE FOR USE IN THE OPERATION AND PROGRAMMING OF GRINDING MACHINES IN THE MANUFACTURING INDUSTRY; INDUSTRIAL PROCESS CONTROL HARDWARE, NAMELY, COMPUTER MONITORS; LAPTOP COMPUTERS, ETHERNET CARDS AND CABLES; COMPUTER NETWORKING HARDWARE, MEMORY CARDS; MICROCHIPS; MICROPROCESSORS; COMPUTER NETWORK HUBS, SWITCHES AND ROUTERS, COMPUTER PERIPHERALS, DISPLAYS AND TERMINALS; COMPUTER WHITEBOARDS; SYSTEM BOARDS AND PROCESSORS; INDUSTRIAL PROCESS CONTROLLERS FEATURING CALL CONTROL, OPERATOR INTERFACE, GAGE INTERFACES AND DATA COLLECTORS; COMPUTER SOFTWARE FOR CONTROL AND MANUFACTURING APPLICATIONS, NAMELY, STATISTICAL PROCESS CONTROL, DATA COLLECTION, AND DISTRIBUTED NUMERICAL CONTROL; MANUFACTURING EXECUTION SYSTEMS AND DOCUMENT MANAGEMENT SOFTWARE; DIGITAL SIGNAL PROCESSING PRODUCTS AND SYSTEMS, NAMELY, INDUSTRIAL AUTOMATION CONTROLS AND PROGRAMMABLE LOGIC CONTROLLERS; MACHINE TOOLS, NAMELY, AN ADAPTIVE CONTROL PRODUCT IN THE NATURE OF AN EXTERNAL CONTROLLER TO OPTIMIZE MACHINE TOOL CUTTING PERFORMANCE OF ROUGH AND SEMI-ROUGH CUTS; DISTRIBUTED AND REMOTE INPUT/OUTPUT COMPUTER HARDWARE DEVICES, INPUT/OUTPUT MODULES, INTERFACE MODULES, POWER SUPPLIES AND MOUNTING HARDWARE THEREFOR; INTRUSION AND BURGLAR ALARM SYSTEMS, SECURITY DEVICES, NAMELY, PROGRAMMING LOGIC COMPUTERS, CONTROL PANELS, ELECTRONIC INTRUSION DETECTORS, ELECTRONIC GLASS-BREAK SENSORS, ELECTRONIC VIBRATION SENSORS, MAGNETIC CONTACTS FOR USE IN SECURITY SYSTEMS, ELECTRONIC SWITCH PLATES, ELECTRONIC MOTION SENSORS FOR ALARM SYSTEMS, ELECTRONIC MOTION SENSITIVE SWITCHES, HARD-WIRE SIRENS, AUDIO SPEAKERS, ELECTRONIC DRIVERS, ACCESS CONTROL AND ALARM MONITORING SYSTEMS; FIRE, HEAT AND SMOKE DETECTING AND ALARM UNITS; COMPUTER CARD OPERATED ACCESS CONTROL SYSTEMS; CARD READERS, CARD ENCODERS, AND ENCODED CARDS FOR USE WITH CARD OPERATED ACCESS CONTROL SYSTEMS; VIDEO CAMERAS; VIDEO OBJECT RECOGNIZERS; VIDEO OBJECT TRACKERS; VIDEO LICENSE PLATE READERS; VIDEO ALARM VERIFIERS; VIDEO FACE RECOGNIZERS; VIDEO VEHICLE RECOGNIZERS; VIDEO TRAFFIC DETECTORS; VIDEO ACCESS DOOR CONTROLLERS; VIDEO INTRUSION DETECTORS; PROCESSING HARDWARE AND SOFTWARE THAT ANALYZES DIGITAL VIDEO IMAGES TO AUTOMATICALLY EXTRACT, RECORD AND REPORT INTELLIGENCE, AND REMOTE VIDEO MONITORING SYSTEMS FOR SECURITY AND SURVEILLANCE APPLICATIONS; CENTRAL VIDEO MONITORS; VIDEO RECORDERS; CAMERAS; CLOSED CIRCUIT VIDEO SYSTEMS; CLOSED CIRCUIT VIDEO SYSTEM COMPRISING ONE OR MORE CAMERAS, AND A CAMERA HOUSING; SHORT RANGE, WIRELESS, RADIO FREQUENCY TRANSCIEVERS; POWER LINE TRANSCIEVERS; COMMUNICATION CONTROL HARDWARE FOR OPERATING CLOSED CIRCUIT CAMERA; COMMUNICATION CONTROL HARDWARE, NAMELY, KEYPAD CONTROLLERS, MATRIX SWITCHERS, MULTIPLEXERS, DIGITAL VIDEO RECORDERS, INTEGRATED PAN-TILT-ZOOM DOMES, REMOTE VIDEO CONTROLLERS, RECEIVERS, ELECTRONIC ALARM, MANAGEMENT CONTROLS AND TRIGGERS, AND VIDEO TRANSMISSION DEVICES SOLD SEPARATELY OR AS PART OF A SYSTEM FOR OPERATING CLOSED CIR-

CUIT CAMERAS; PERSONAL DIGITAL ASSISTANT DEVICES CONFIGURED FOR USE BY REAL ESTATE PROFESSIONALS; COMMUNICATIONS INTERFACE DEVICES FOR USE WITH PERSONAL DIGITAL ASSISTANT DEVICES, FIBER-OPTIC TRANSMISSION SYSTEMS, NAMELY, FIBER OPTIC TRANSMITTERS, RECEIVERS AND TRANSCIEVERS USED IN THE TRANSMISSION OF VIDEO, AUDIO, AND DATA SIGNALS OVER OPTICAL FIBER; ELECTRICAL SWITCHES; ELECTRO-MECHANICAL LOCKS; MAGNETIC LOCKS; ELECTRIC KEYS; HAND HELD ELECTRONIC HARDWARE FOR RECEIVING, CONTROLLING, STORING, MANIPULATING, DISPLAYING AND TRANSMITTING DATA AND FOR OPERATING ELECTRONIC LOCKS; ELECTRONIC ACCESS CARDS AND READERS AND ENCODERS THEREFORE; MAGNETIC ASSESS CARDS AND READERS AND ENCODERS THEREFORE; SMART ACCESS CARDS AND READERS AND ENCODERS THEREFORE; PROXIMITY CARDS AND READERS AND ENCODERS THEREFORE; ELECTRONIC KEY FOBS AND READERS AND ENCODERS THEREFORE; BAR CODE ACCESS CARDS AND READERS, ENCODERS; ACCESS KEYPADS; RADIO FREQUENCY TRACKING TAGS; TRACKING AND CONTROL SYSTEM COMPRISING ONE OR MORE RADIO FREQUENCY TAGS, TRANSCIEVERS, AND SENSORS USED TO DETERMINE AND MONITOR THE LOCATION AND MOVEMENT OF TANGIBLE ASSETS, INVENTORY AND INDIVIDUALS; INFRARED SENSORS; COMPUTER HARDWARE AND SOFTWARE FOR FACILITIES MANAGEMENT AND CONTROLLING FACILITY ACCESS SYSTEMS AND COMPONENTS THEREFORE, NAMELY, CONTROL PANELS, ACCESS CARD READERS, AND EQUIPMENT AND SYSTEMS FOR VIDEO IMAGING, VIDEO MONITORING, DIGITAL HARD DRIVE RECORDING, NETWORK TRANSMISSION AND REMOTE ACCESS; NETWORKED DIGITAL VIDEO STORAGE SERVERS FOR ACCESS CONTROL AND SURVEILLANCE APPLICATIONS, ALARM MONITORING AND SECURITY; COMPUTER SOFTWARE AND HARDWARE FOR CONTROLLING AND OPERATING SECURITY AND ACCESS SYSTEM COMPRISING LOCKS, DOORS, ACCESS, AND IDENTIFICATION; DEVICES AND SECURITY ENCLOSURES IN THE NATURE OF ELECTRONIC BOXES FOR SECURING KEYS; SURVEILLANCE EQUIPMENT SOLD INDIVIDUALLY AS COMPONENTS OR TOGETHER AS A SYSTEM COMPRISING ONE OR MORE SURVEILLANCE CAMERAS, COVERT CAMERAS, CLOSE CIRCUIT TELEVISION CAMERAS, CAMERA HOUSINGS, CAMERA MOUNTS, CAMERA LENSES, VIDEO MONITORS, VIDEO RECORDERS, DIGITAL RECORDERS, VIDEO STORAGE MEDIA, VIDEO SWITCHES, CONTROL PANELS, KEYPAD CONTROLLERS, JOYSTICK CONTROLLERS, ELECTRONIC DISPLAY INTERFACES FOR ALARMS AND ACCESS CONTROL EQUIPMENT, TRANSCIEVERS, RECEIVERS, TRANSMITTERS, SIGNAL PROCESSORS, MULTIPLEXERS, MATRIX SWITCHES, CONTROLLERS, CONTROL PANEL HOUSING, SWITCH HOUSING, TRANSFORMERS SWITCHES, SPLITTERS, COAXIAL CABLES, CONNECTORS, MOTION DETECTORS, MICROPHONES AND SPEAKERS; COMPUTER USER INTERFACE SOFTWARE AND CONTROL SOFTWARE FOR MANAGING SECURITY, FIRE AND ACCESS SYSTEMS; ELECTRIC LOCKS; HAND-HELD ELECTRONIC COMPUTER AND COMMUNICATION HARDWARE FOR RECEIVING, CONTROLLING, STORING, MANIPULATING, DISPLAYING AND TRANSMITTING DATA FOR OPERATING ELECTRONIC LOCKS, ELECTRONIC KEY FOBS, READERS AND ENCODERS; DATA PROCESSING SOFTWARE AND COMPUTER HARDWARE; POWER SUPPLIES, NAMELY, BATTERIES, VOLTAGE AND CURRENT REGULATORS AND TRANSFORMERS; CONTROL PANELS, NAMELY, ELECTRONIC APPARATUS ADAPTED TO ELECTRICALLY MONITOR A PRE-DETERMINED ACTIVITY AND ACTIVATE A BURGLAR ALARM; SIREN SPEAKERS; AND ELECTRONIC SIREN DRIVERS, NAMELY, TONE GENERATORS AND AMPLIFIERS ADAPTED TO BE USED FOR SIRENS; COMPUTER SOFTWARE FOR CONTROL COMMUNICATION HARDWARE FOR OPERATING AND CONTROLLING CLOSED CIRCUIT CAMERAS; SWITCH UNITS INCORPORATING MAGNETICALLY ACTUATED REED SWITCHES FOR USE IN BURGLARY AND FIRE SENSING ALARM SYSTEMS, IN INDUSTRIAL POSITION SENSING APPARATUS, IN REVOLUTION COUNTERS, IN EQUIPMENT CABINET SAFETY INTERLOCK SYSTEMS, IN INDUSTRIAL POSITION CONTROLLING

APPARATUS, IN ELECTRICAL CABLES AND IN PUMP AND VALVE CONTROLLING APPARATUS AND HOME SECURITY ALARM SYSTEMS; ELECTRICAL AND ELECTRONIC CHECKING APPARATUS, NAMELY, DETECTORS, SCANNERS AND MONITORS FOR SCREENING INDIVIDUALS, BAGGAGE, AND CARGO FOR THE PRESENCE OF PARTICULAR SUBSTANCES; ELECTRICAL AND ELECTRONIC CHECKING APPARATUS, NAMELY, DETECTORS, SCANNERS AND MONITORS FOR SCREENING INDIVIDUALS, BAGGAGE, AND CARGO FOR THE PRESENCE OF EXPLOSIVES AND/OR NARCOTICS; APPARATUS FOR DETECTING PRESENCE OF EXPLOSIVES AND OTHER CONTRABAND; TIME OR CONDITION SENSING APPARATUS FOR INITIATING AND CONTROLLING REGENERATION OR BACKWASH CYCLES FOR WATER TREATMENT EQUIPMENT; CONTROL VALVES FOR WATER CONDITIONING AND WATER FILTRATION EQUIPMENT; BIOREACTORS FOR CULTURING CELLS; PORTABLE ANALYTICAL INSTRUMENTS NAMELY, A PROBE WITH A MICROPROCESSOR BASED DATA CONVERSION LOGGER FOR MEASUREMENT OF ORGANIC AND INORGANIC CHEMICALS IN WATER; FILTERS AND FILTER HOUSINGS FOR LABORATORY USE; FLUID SEPARATION APPARATUS FOR LABORATORY USE; MEMBRANE FILTERS FOR LABORATORY USE; SILT DENSITY MEASURING DEVICE; DEIONIZATION UNITS FOR LABORATORY USE; FLUID FLOW CONTROL DEVICES, NAMELY, PUMPS, VALVES, FLOW METERS AND REGULATORS FOR LABORATORY USE; OZONE MONITORS; LABORATORY EQUIPMENT, NAMELY, POROUS MICROTITER PLATES FOR USE IN CELL BIOLOGY AND OTHER LIFE SCIENCE APPLICATIONS; ELECTRONIC WATER AND PROCESS TREATMENT CONTROLS, NAMELY, APPARATUS FOR USE IN THE TREATMENT OF COMMERCIAL AND INDUSTRIAL WATER SYSTEMS, BOILER WATER SYSTEMS, COOLING WATER SYSTEMS, AND CLOSED WATER SYSTEMS, PULP AND PAPER PROCESSING SYSTEMS, FUEL PROCESSING SYSTEMS, AND METAL PROCESSING SYSTEMS TO ANALYZE THE CHEMISTRY OF THE SYSTEM, DETERMINE THE PROPER TREATMENT PROGRAM, APPLY THE DESIRED TREATMENT AND MONITOR THE EFFECTIVENESS OF THE TREATMENT; COMPUTER SOFTWARE FOR DATA MANAGEMENT IN THE WATER TREATMENT AND PULP AND PAPER FIELDS; ELECTRONIC CONTROLLERS USED FOR PROCESSING INFORMATION IN THE WATER TREATMENT AND PULP AND PAPER FIELDS; APPARATUS FOR USE IN INDUSTRIAL WATER SYSTEMS TO MEASURE AND CONTROL PH AND CONDUCTIVITY; APPARATUS FOR FEEDING CHEMICAL TO AN INDUSTRIAL, COMMERCIAL OR MUNICIPAL WATER SYSTEM IN MEASURED AMOUNTS; ELECTRONIC TEST APPARATUS FOR USE IN WATER TREATMENT; LABORATORY TESTING EQUIPMENT—NAMELY, DEPOSITION AND CORROSION RATE TESTERS; MOBILE LABORATORY EQUIPPED WITH EQUIPMENT AND INSTRUMENTATION TO MONITOR AND MEASURE PH, CONDUCTIVITY, AND CHROMATE CONCENTRATION OF INDUSTRIAL AND DOMESTIC WATERS, TO CONDUCT INORGANIC ANALYSIS OF WATER AND TO CONDUCT MICROBIOLOGICAL TESTING OF WATER; ELECTRONIC AND ELECTROCHEMICAL PRODUCTS, NAMELY, FUEL CELLS; PHOTOVOLTAIC SOLAR CELLS AND CELL MODULES, PHOTOVOLTAIC SOLAR HYBRID MODULES, ELECTRONICAL SENSORS FOR MEASURING SOLAR RADIATION, SOLAR CELLS; APPARATUS FOR CONVERTING ELECTRONIC RADIATION TO ELECTRICAL ENERGY, NAMELY, PHOTOVOLTAIC SOLAR MODULES AND PARTS THEREFOR; PRINTERS, LASER PRINTERS, INK JET PRINTERS, MULTIFUNCTION AND ALL IN ONE PRINTERS; ELECTRONIC HAND-HELD UNITS FOR THE WIRELESS RECEIPT AND TRANSMISSION OF DATA THAT ENABLES THE USER TO KEEP TRACK OF OR MANAGE PERSONAL INFORMATION AND HAS THE CAPACITY TO TRANSMIT AND RECEIVE VOICE, IMAGE AND VIDEO COMMUNICATION; SOFTWARE FOR THE SYNCHRONIZATION OF DATA BETWEEN A REMOTE STATION OR UNIT AND A FIXED OR REMOTE STATION OR UNIT AND SOFTWARE WHICH ENABLES AND PROVIDES ONE-WAY AND TWO-WAY WIRELESS CONNECTIVITY TO DATA; PORTABLE DIGITAL ELECTRONIC DEVICES FOR RECORDING, ORGANIZING, TRANSMITTING, MANIPULATING, AND REVIEWING TEXT, DATA, IMAGE, AND AUDIO FILES AND OPERATING SOFTWARE THEREFOR; HAND-HELD ELECTRONIC DEVICES FOR THE WIRE-

LESS RECEIPT AND TRANSMISSION OF DATA; SOFTWARE FOR THE REDIRECTION OF MESSAGES, E-MAIL, AND OTHER DATA FROM A PERSONAL COMPUTER OR A SERVER TO ONE OR MORE HAND-HELD ELECTRONIC DEVICES; COMPUTER SOFTWARE AND PROGRAMS FOR MANAGEMENT AND OPERATION OF WIRELESS COMMUNICATION DEVICES; PORTABLE TELECOMMUNICATION INSTANT MESSAGING DEVICES; COMPUTER SOFTWARE FOR ACCESSING, SEARCHING, INDEXING AND RETRIEVING INFORMATION AND DATA FROM GLOBAL COMPUTER NETWORKS AND GLOBAL COMMUNICATION NETWORKS, AND FOR BROWSING AND NAVIGATING THROUGH WEB SITES ON SAID NETWORKS; COMPUTER SOFTWARE FOR SENDING AND RECEIVING SHORT MESSAGES AND ELECTRONIC MAIL AND FOR FILTERING NON-TEXT INFORMATION FROM THE DATA; HAND-HELD ELECTRONIC DEVICES FOR DATA, VOICE, IMAGE AND VIDEO COMMUNICATION; COMPUTER GAME SOFTWARE FOR MOBILE HANDSETS; ELECTRONIC GAME SOFTWARE FOR MOBILE HANDSETS; BATTERIES, DRY CELLS, RECHARGEABLE BATTERIES, BATTERY CHARGERS, STORAGE BATTERIES, SOLAR CELLS, FUEL CELLS; CARBON RODS FOR USE AS FUEL CELLS IN DRY BATTERIES, CARBON RODS FOR WELDING USE; WIRING APPARATUS, NAMELY, ELECTRICAL CONNECTORS, ELECTRIC CABLES, ELECTRICAL CONDUITS, FLOOR DUCTING ESPECIALLY FOR HOUSING ELECTRIC CABLES, BALLAST FOR DISCHARGE LAMPS, DIMMER SWITCHES, CIRCUIT BREAKERS, MAGNETIC CONTACTORS AND STARTERS, CIRCUIT PROTECTORS, SWITCH GEARS, ELECTRIC JUNCTION BOXES, APPLIANCE SWITCHES, OUTLET SOCKETS, ELECTRICAL PLUGS, INSULATING MATERIALS IN THE NATURE OF INSULATED ELECTRICAL CONNECTORS, WIRES AND CABLES, ELECTRIC TIME SWITCHES; VIDEO ENTRY PHONES, INTERCOM SYSTEMS, ELECTRIC DOOR CHIMES, ELECTRIC BUZZERS, FIRE ALARMS, GAS LEAKAGE ALARMS, BURGLAR ALARMS, PORTABLE EMERGENCY BUZZERS; ACOUSTIC MACHINES AND APPARATUS, NAMELY, RADIOS, CASSETTE TAPE PLAYERS AND RECORDERS, RADIO CASSETTE RECORDERS, PORTABLE CASSETTE TAPE PLAYERS, COMPACT DISC PLAYERS AND RECORDERS, MINI DISC PLAYERS AND RECORDERS, MINI DISC DECKS, DVD (DIGITAL VERSATILE DISC) AUDIO PLAYERS AND RECORDERS, SECURE DIGITAL PLAYERS AND RECORDERS, SECURE DIGITAL CARD, AUDIO SPEAKERS, STEREO TUNERS, AMPLIFIERS, STEREO COMPONENT SYSTEM COMPRISED OF TUNERS, AMPLIFIERS, AUDIO SPEAKERS, RECORD PLAYERS, GRAPHIC EQUALIZERS, RADIOS INCORPORATING CLOCKS, IC (INTEGRATED CIRCUIT) RECORDERS, DIGITAL SOUND PROCESSORS, HEADPHONES, EARPHONES, MICROPHONES, SING-ALONG CASSETTE PLAYERS AND RECORDERS IN THE NATURE OF KARAOKE PLAYERS, PRE-RECORDED COMPACT DISC FEATURING SPORTS, ELECTRIC MEGAPHONES, AUDIO AND VIDEO RECORDERS AND PLAYERS FOR LANGUAGE LABORATORIES, CAR AUDIO SYSTEMS COMPRISED OF STEREOS, SPEAKERS, AMPLIFIERS, EQUALIZERS, CROSSOVERS AND SPEAKER HOUSINGS, PUBLIC ADDRESS SYSTEMS, AUDIO MIXERS, AUDIO EQUIPMENT CLEANERS, NAMELY, MAGNETIC HEAD CLEANERS, AUDIO CABLES, VIDEO CABLES; AUDIO-VISUAL MACHINES AND APPARATUS, NAMELY, TELEVISION RECEIVERS, CATHODE RAY TUBE DISPLAYS, CATHODE RAY TUBES, TELEVISION SIGNAL IMAGE PICK UP TUBES, PLASMA TELEVISION RECEIVERS, PLASMA DISPLAYS, LCD (LIQUID CRYSTAL DISPLAY) TELEVISION RECEIVERS, LIQUID CRYSTAL DISPLAYS, COMBINED TELEVISION RECEIVER WITH VIDEO TAPE RECORDER, COMBINED TELEVISION RECEIVER WITH AUDIO AND VIDEO DISC PLAYER, ANTENNAS, TUNERS FOR SATELLITE BROADCASTING, TUNERS FOR TELEVISION, INTERNET DISPLAY TERMINALS, VIDEO PROJECTORS, VIDEO CASSETTE RECORDERS, CAMCORDERS, VIDEO CAMERAS, VIDEO PRINTERS, LASER DISC PLAYERS, VIDEO CD (COMPACT DISC) PLAYERS, VIDEO CDS (COMPACT DISC) FEATURING SPORTS, DVD (DIGITAL VERSATILE DISC) VIDEO PLAYERS AND RECORDERS, COLOR VIDEO SYSTEMS FOR LARGE-SCALE DISPLAY, COMPRISED OF VIDEO PROJECTOR, AUDIO SPEAKERS, CABLE TELEVISION SYSTEMS, NAMELY, CONVERTERS AND TRANSMITTERS, HARD DISK DRIVERS, VIDEO IMAGERS, ELEC-

TRIC OPTICAL DISPLAY BOARDS, MULTI-PURPOSE ELECTRIC DISPLAY SYSTEMS, COMPRISED OF LED (LIGHT EMITTING DIODES) MONITORS AND SCREENS, CLOSED CIRCUIT VIDEO EQUIPMENT SYSTEMS, COMPRISED OF CAMERAS AND MONITORS FOR VIDEO SURVEILLANCE, DVDS (DIGITAL VERSATILE DISC) FEATURING SPORTS, TELEVISION CAMERAS, VIDEO SWITCHERS, ELECTRONIC EDITING CONTROLLER, LIGHT EMITTING DIODE DISPLAY; OPTICAL-DISC MACHINES AND APPARATUS, NAMELY, OPTICAL DISC DRIVES, OPTICAL DISC RECORDERS, OPTICAL DISC PLAYERS, OPTICAL DISC CHANGERS, BLANK OPTICAL DISCS; COMMUNICATION MACHINES AND APPARATUS, NAMELY, FACSIMILE TRANSCIEVERS, TRANSCIEVERS, TELEPHONES, CELLULAR MOBILE TELEPHONES, CARRY CASE FOR CELLULAR MOBILE TELEPHONE, TELEPHONE ANSWERING MACHINES, PRIVATE AUTOMATIC BRANCH TELEPHONE SWITCHING APPARATUS, GLOBAL POSITIONING SYSTEM RECEIVERS, RADIO TELEPHONES, MARINE RADARS, RADIO PAGING RECEIVERS, MOBILE COMMUNICATION SYSTEMS AND MULTI-CHANNEL ACCESS RADIO SYSTEMS, COMPRISED OF RADIO EMITTERS, RADIO RECEIVERS, RADIO EMITTERS/RECEIVERS, RADIO REPEATERS, RADIO SIGNAL AMPLIFIERS, RADIO ANTENNAS, RADIO-TELEPHONES; ELECTRONIC TRAFFIC INFORMATION BOARDS, VIDEO TELECONFERENCING SYSTEMS, COMPRISED OF CAMERAS, TRANSMITTERS, RECEIVERS AND PLAYERS, PERSONAL HANDY-PHONE SYSTEMS, COMPRISED OF MOBILE TELEPHONES, PAGERS, LOCAL AREA NETWORK (LAN) HARDWARE AND OPERATING SOFTWARE, AV (AUDIO/VISUAL) ENCODERS AND DECODERS, IN-CAR NAVIGATION APPARATUS, ELECTRONIC APPARATUS FOR THE COLLECTION OF ROAD TOLLS, GPS (GLOBAL POSITIONING SYSTEM) ANTENNA; CHECKING AND SUPERVISING APPARATUS AND INSTRUMENTS, NAMELY, ELECTRIC DOOR OPENERS, COMMUNICATION AND MONITORING SYSTEM FOR APARTMENT BUILDINGS COMPRISED OF VIDEO CAMERAS, COMPUTER MONITORS, INTERCOMS, INTRUDER DETECTION SYSTEMS, COMPRISED OF BURGLAR ALARMS, VIDEO MONITORS, AUTOMATED CONTROL SYSTEM COMPRISED OF HARDWARE AND SOFTWARE FOR MONITORING AND CONTROLLING FUNCTIONS WITHIN BUILDINGS AND ELECTRIC MULTI-LAYER SECURITY APPLIANCES; AUTOMATIC CONTROLLING MACHINES AND INSTRUMENTS, NAMELY, ELECTRIC NOTICE BOARDS, TRAFFIC MANAGEMENT EQUIPMENT, NAMELY, DISPLAY MONITORS, COMPUTERS, AUTO COMPASSES, SOFTWARE TO MANAGE TRAFFIC, AUTOMATED TRAFFIC-SIGNAL CONTROL APPARATUS, BUS LOCATION SYSTEM, AND ULTRASONIC VEHICLE DETECTORS, ELECTRIC LIGHT DIMMERS, ELECTRIC DAYLIGHT SWITCHES, INVERTERS, PROGRAMMABLE LOGIC CONTROLLERS, TRANSFORMERS, POWER CAPACITORS; DATA PROCESSING EQUIPMENT, NAMELY, COMPUTERS AND COMPUTER PERIPHERAL DEVICES, COMPUTERS, WORD PROCESSORS, IMAGE SCANNERS FOR PERSONAL COMPUTER, PRINTERS, PC (PERSONAL COMPUTER) CARDS, COMPUTER KEYBOARDS, COMPUTER MOUSE, CD-ROM (COMPACT DISC-READ ONLY MEMORY) DRIVES, FLOPPY DISK DRIVES, ELECTRONIC AND MAGNETIC CARD READER AND WRITERS, BAR CODE READERS, TIME RECORDERS, MOBILE DATA TERMINAL, ELECTRONIC CASH REGISTERS, ELECTRONIC EQUIPMENT FOR POINT-OF-SALES (POS) SYSTEMS, NAMELY, POINT-OF-SALE TERMINALS, BAR CODE READERS, OPTICAL READERS, ADVERTISEMENT DISPLAY MONITORS, KEYBOARDS, PRINTERS, SCANNERS, RADIO TRANSMITTERS, RADIO RECEIVERS, COMPUTER HARDWARE, AND COMPUTER OPERATING SOFTWARE, DATA COLLECTION TERMINALS IN THE NATURE OF COMPUTER TERMINALS, PDA (PERSONAL DIGITAL ASSISTANTS), DVD-RAM/ROM (DIGITAL VERSATILE DISC-RANDOM ACCESS MEMORY/READ ONLY MEMORY) DRIVE, CAD/CAM (COMPUTER AIDED DESIGN/COMPUTER AIDED MANUFACTURING) DRIVES, HARD DISC DRIVES, ELECTRONIC CALCULATORS, UNINTERRUPTED POWER SUPPLIES FOR COMPUTERS AND COMMUNICATION AND BROADCASTING EQUIPMENT; EXTERNAL STORAGE MEDIA, NAMELY, BLANK VIDEO CASSETTE TAPES, HEAD CLEANING TAPES FOR AUDIO AND VIDEO RECORDERS, D-VHS (DATA VIDEO HOME SYSTEMS) TAPES FEATURING SPORTS,

AND COMPUTER PERIPHERALS; VIDEO CASSETTE TAPES FEATURING SPORTS, AUDIO CASSETTE TAPES FEATURING SPORTS, BLANK FLOPPY COMPUTER DISCS, OPTICAL DISCS FEATURING SPORTS, MINIDISCS FEATURING SPORTS, DVDS (DIGITAL VERSATILE DISCS) FEATURING SPORTS, IC (INTEGRATED CIRCUIT) MEMORY CARDS; WEIGHING AND MEASURING APPARATUS AND INSTRUMENTS, NAMELY, THERMOLUMINESCENCE DOSIMETERS, ELECTRONIC COUNTERS, AMMETERS, POWER CONSUMPTION METERS, CLAMP METERS, ELECTRIC LEAKAGE METERS, ELECTRIC INSULATION METERS, THERMOMETERS, MEASUREMENT SYSTEM PROCESSORS, MULTI-CIRCUIT TYPE ELECTRIC POWER MONITOR, ELECTRONIC MICRO-PRECISION MEASUREMENTS, STEP COUNTER, NAMELY, PEDOMETERS, AUDIO AND VIDEO SIGNAL ANALYZERS, OSCILLOSCOPES, MODULATORS, VOLTMETERS, AUDIO AND VIDEO SIGNAL DISTORTION METERS; ELECTRONIC SENSORS, NAMELY, PHOTOELECTRIC SENSOR, TEMPERATURE SENSORS, POSITION SENSORS, ANGULAR SPEED SENSORS, ROTATION SENSORS, ANGLE SENSORS, DEW SENSORS; ELECTRIC COMPONENTS, NAMELY, LIGHT EMITTING DIODES, LIQUID CRYSTALS DISPLAYS, LIQUID CRYSTAL DISPLAY MODULES, MAGNETRONS, DIODES, TRANSISTORS, THERMOSTATS, INTEGRATED CIRCUITS, LSI (LARGE SCALE INTEGRATION) CIRCUITS, SEMICONDUCTOR MEMORY DEVICES, ONE-CHIP MICROCOMPUTERS, ELECTRIC CONDENSER MICROPHONE, HALFTONE IMAGE PROCESSORS, THERMAL PRINTING HEADS FOR PRINTERS, MAGNETIC HEADS FOR AUDIO CASSETTE PLAYERS, PERMANENT MAGNETS, ELECTRICAL CONNECTORS, ELECTRIC RELAYS, LASERS FOR USE IN MANUFACTURING SEMICONDUCTORS, IMAGE SENSORS FOR CCDs (CHARGE COUPLED DEVICES), FILM CAPACITOR, ELECTRIC TUNER UNITS, ELECTRIC HIGH FREQUENCY UNITS, ELECTRIC COIN VALIDATING UNITS, ELECTRIC MONETARY BILL VALIDATING UNITS, VOLTAGE CONTROLLED OSCILLATORS, PPL (PHASE-LOCKED LOOP) SYNTHESIZER MODULES, ELECTRONIC WIRELESS COMMUNICATION MODULE UNIT, OPTICAL TRANSMISSION COMPONENTS, NAMELY, CONNECTORS FOR OPTICAL FIBER, PRINTED WIRING BOARDS IN THE NATURE OF CIRCUIT BOARDS, SPEAKER COMPONENTS, NAMELY, SPEAKER ENCLOSURES, SPEAKER DRIVERS, POWER SUPPLIES, AC (ALTERNATING CURRENT) ADAPTERS, CONVERGENCE MAGNETS, AND ELECTRICAL COIL INDUCTORS, CAPACITORS FOR ELECTRICAL APPLIANCES, FILTERS OF ELECTRIC SIGNALS, TRANSFORMERS, DEFLECTION YOKE THERMISTORS, VARISTORS, ACOUSTO-OPTIC DEVICES, NAMELY, RESISTORS, POTENTIOMETERS, ENCODERS, PRINTER UNITS, HYBRID IC (INTEGRATED CIRCUIT) CARDS, ELECTRONIC COMPONENTS, NAMELY, PIEZOELECTRIC SWITCHES, HEAT SINK WIRING BOARDS, TRANSPARENT TOUCH PANELS, ELECTRO LUMINESCENT DISPLAY UNITS, ELECTRO-MAGNETIC RESISTORS, THERMOMAGNETIC CUT-OFFS DEVICES; ELECTRIC UTENSILS FOR THE HOUSEHOLD, NAMELY, ELECTRIC FLAT IRONS, ELECTRIC HAIR CURLERS, ELECTRIC HAIR IRONS, ELECTRIC TIMERS AND ELECTRIC PANTS PRESSES; ELECTRIC ARC WELDERS, WELDING ELECTRODES; DATA PROCESSORS IN PARTICULAR FOR FINANCIAL APPLICATIONS; COMPUTER OPERATING PROGRAMS; COMPUTER HARDWARE AND SOFTWARE FOR THE DEVELOPMENT, MAINTENANCE AND USE OF LOCAL AND WIDE AREA COMPUTER NETWORKS; SYSTEMS FOR READING MEMORY CARDS AND SYSTEMS FOR READING DATA IN MEMORIES IN THE NATURE OF MEMORY READERS FOR READING INTEGRATED CIRCUIT MEMORIES AND BANKING CARD MEMORIES; CASH DISPENSERS; AUTOMATED BILLING MACHINES FOR PROCESSING ACCOUNTING INFORMATION; MAGNETICALLY ENCODED CARDS, NAMELY, MAGNETIC CARDS AND CARDS WITH INTEGRATED CIRCUITS, IN PARTICULAR, FOR FINANCIAL DEBIT AND CREDIT APPLICATIONS; ELECTRONIC CARD READER, PRINTERS FOR USE WITH DATA PROCESSING SYSTEMS AND FINANCIAL TRANSACTION SYSTEMS; ENCODERS AND DECODERS; MODEMS; ELECTRONIC DATA CARRIER CARDS, NAMELY, BLANK SMART CARDS, MAGNETIC CODED CARD READERS, ELECTRONIC DATA CARRIER CARD READERS, NAMELY, SMART CARD READERS, ELECTRONIC ENCRYPTION UNITS, COM-

PUTER HARDWARE, COMPUTER TERMINALS, COMPUTER SOFTWARE FOR DATA COLLECTION, DATABASE MANAGEMENT AND DATA ANALYSIS FOR USE IN CONNECTION WITH PROVIDING FINANCIAL, BANKING AND TELECOMMUNICATIONS SERVICES; ELECTRICAL AND ELECTRONIC GOODS, NAMELY, CALCULATING MACHINES, ELECTRONIC DAY PLANNERS; BANKING CARDS, NAMELY, CREDIT CARDS AND DEBIT CARDS USING MAGNETIC MEMORIES AND INTEGRATED CIRCUIT MEMORIES; BANKING CARDS, NAMELY, CREDIT CARDS AND DEBIT CARDS HAVING INTEGRATED CIRCUITS AND MICROPROCESSORS; MEMORY CARDS; AUTOMATIC CASH DISPENSERS; EQUIPMENT FOR DATA PROCESSORS AND COMPUTERS, NAMELY, CARDS EQUIPPED WITH MICROPROCESSORS AND INTEGRATED CIRCUITS; COMPUTER HARDWARE IN THE NATURE OF INTEGRATED CIRCUIT CARDS AND CARD READERS CONTAINING TRANSPONDERS AND OTHER PROXIMITY PAYMENT DEVICES; MOUSE PADS; FLUID CONTROL DEVICES, NAMELY, EXPANSION VALVES, FLOW METERS, PRESSURE SWITCHES, SEQUENCE TIMERS, REGULATORS, LEVELERS, EJECTORS, AND ELECTRICAL CONTROLS AND SWITCHES; ELECTRICAL INDUCTORS, ELECTRICAL TRANSFORMERS, ELECTRIC REGULATING AND CONTROLLING DEVICES, ELECTRIC MEASURING INSTRUMENTS, SWITCHBOARDS; ELECTRIC DEVICES FOR ATTRACTING AND KILLING INSECTS; ELECTROSTATIC EMISION CONTROL DEVICES, NAMELY, ELECTROSTATIC PRECIPITATORS FOR REDUCING PARTICULATE EMISSION IN INDUSTRIAL APPLICATIONS; ELECTRONIC NOTICE BOARDS (U.S. CLS. 21, 23, 26, 36 AND 38).

CLASS 11—ENVIRONMENTAL CONTROL APPARATUS

FOR SOLAR COLLECTORS, SOLAR HEAT COLLECTION PANELS; SOLAR LIGHT FIXTURES, NAMELY, INDOOR AND OUTDOOR SOLAR POWERED LIGHTING UNITS AND FIXTURES; SOLAR THERMAL INSTALLATIONS, NAMELY, SOLAR THERMAL MODULES; SOLAR WATER HEATERS; ROOFING, NOT OF METAL, INCORPORATING SOLAR CELLS; DOMESTIC ELECTRIC AND GAS COOKING APPLIANCES, NAMELY, COOKING RINGS, GAS AND ELECTRIC STOVES; GAS AND ELECTRIC OVENS AND COOK TOPS; HEAT EXCHANGERS FOR USE IN THE DISTRIBUTED RESIDENTIAL AND PORTABLE FUEL CELL POWER APPLICATIONS; CHEMICAL HEAVY WALL REACTORS AND NUCLEAR REACTORS AND ACCESSORIES AND COMPONENT PARTS THEREOF, NAMELY, HEAT PUMPS, STEAM VALVES AND VALVES FOR REGULATING THE FLOW OF GASES AND LIQUIDS; ELECTRIC LAMPS; ELECTRIC LIGHTING FIXTURES AND THEIR PARTS, NAMELY, LAMP-SHADES; ELECTRIC REFRIGERATORS, FREEZERS, AIR CONDITIONING APPARATUS; MICROWAVE OVENS FOR COOKING; WALL COOKING OVENS FOR DOMESTIC USE; ELECTRIC AND GAS FOOD WARMING DRAWERS; CONVECTION OVENS, ELECTRIC AND GAS COOK TOPS; ELECTRIC AND GAS COOKING OVENS AND RANGES; VENTILATION HOODS FOR STOVES; AND VENTILATING EXHAUST FANS; WATER FILTERS; WATER SOFTENING UNITS; CLOTHES DRYERS; ELECTRIC FANS, CEILING FANS, FLASH-LIGHTS; LAMPS AND LIGHTS FOR VEHICLES; ELECTRIC LIGHTS FOR CHRISTMAS TREES; FLUID SEPARATION UNITS; FLUID CONCENTRATION UNITS; FLUID RECYCLING UNITS; POLYMERIC MEMBRANE MATERIAL FOR USE IN THE SEPARATION OF FLUIDS; FILTER APPARATUS USED FOR FILTERING SOLIDS FROM GASES AND LIQUIDS OR FILTERING LIQUIDS FROM GASES, AND FOR FILTERING ONE IMMISCIBLE LIQUID FROM ANOTHER; SPIRALLY-WOUND ELEMENTS OR CARTRIDGES CONTAINED WITHIN A TUBULAR PLASTIC SLEEVE FOR CONCENTRATING PRODUCTS AND REMOVING IMPURITIES IN FLUID TREATMENT SYSTEMS; WATER CONDITIONING UNITS FOR RESIDENTIAL PURPOSES; WATER TREATMENT EQUIPMENT, NAMELY, REVERSE OSMOSIS MODULES AND MEMBRANES THEREFORE; WATER PURIFICATION UNITS AND SYSTEMS CONSISTING OF CLARIFIERS, ELECTRO-DEIONIZATION SYSTEMS, CONDENSATE POLISHERS, VACUUM DEGASIFICATION UNITS, ULTRA FILTRATION UNITS, ULTRAVIOLET STERILIZERS, ION EXCHANGERS, ACID AND CAUSTIC REGENERA-

TION SYSTEMS, REVERSE OSMOSIS SYSTEMS, FORCED DRAFT DECARBONATOR UNITS, FILTERS, CHEMICAL FEED SYSTEMS AND BULK STORAGE UNITS, SOLD WITH AUTOMATIC CONTROLS AND INSTRUMENTS TO MONITOR OPERATING PARAMETERS OF THE UNITS AND SYSTEMS ELECTRO-CHEMICAL LIQUID PURIFICATION UNITS FOR USE IN THE INDUSTRIAL, COMMERCIAL AND MUNICIPAL SECTORS; WATER FILTERING UNITS FOR DOMESTIC, COMMERCIAL AND INDUSTRIAL USE; WASTE WATER PURIFICATION UNITS; WATER PURIFYING UNITS FOR POTABLE WATER FOR DOMESTIC, COMMERCIAL AND INDUSTRIAL USE; FLUID SEPARATION UNITS, NAMELY, INDUSTRIAL FLUID FILTERS; RECYCLING UNITS, NAMELY, FLUID PURIFICATION UNITS; WATER TREATMENT EQUIPMENT, NAMELY, CARTRIDGE FILTRATION UNITS; WATER TREATMENT EQUIPMENT FOR HOUSEHOLD USE, NAMELY, WATER SOFTENERS AND WATER CONDITIONERS; MEDIA FILTERS AND DEPTH FILTERS FOR REMOVING SEDIMENTS, IRON, SULFUR, TASTES AND ODORS FROM WATER; REVERSE OSMOSIS WATER PURIFICATION UNITS; DEPTH FILTER UNITS AND DEPTH FILTER CARTRIDGES FOR LIQUID AND AIR FILTRATION FOR DOMESTIC, INDUSTRIAL, AND COMMERCIAL USE; DISPOSABLE CARTRIDGE FILTERS FOR INDUSTRIAL WATER FILTRATION; APPARATUS AND INSTALLATIONS FOR LIGHTING, NAMELY, INCANDESCENT LAMPS, GLOW SWITCH STARTERS, SCREW-IN FLUORESCENT LAMPS, FLUORESCENT LAMPS, TUNGSTEN HALOGEN LAMPS, FLASH LIGHTS, FLUORESCENT LANTERNS, LAMPS, FLUORESCENT LIGHTING FIXTURES, DYNAMO LIGHTS FOR BICYCLES, GERMICIDAL LAMPS FOR PURIFYING AIR, AND LIGHTING FIXTURES; APPARATUS AND INSTALLATIONS FOR COOKING, NAMELY, AUTOMATIC BREAD MAKERS FOR DOMESTIC USE, ELECTRIC KETTLE, ELECTRIC RICE COOKER, GAS FUELED RICE COOKERS, ELECTRIC SLOW COOKERS, ELECTRIC ROASTERS, OVENS FOR COOKING, ELECTRIC TOASTERS, ELECTRIC COFFEE MAKERS, ELECTRIC COOKING STOVES, ELECTRIC THERMO POTS, GAS COOKERS, INDUCTION HEATING HOBS, ELECTRIC BARBECUE GRIDDLES, MICROWAVE OVENS, GAS COOKING STOVES WITH OVENS, ELECTRIC FOOD-PANS, SINKS; APPARATUS AND INSTALLATIONS FOR REFRIGERATION AND FREEZING, NAMELY, REFRIGERATORS, FREEZERS, COLD AND HOT WATER DISPENSERS, FREEZING AND REFRIGERATING SHOWCASES, ELECTRIC WATER COOLERS, ELECTRIC ICE MAKERS; VENTILATING APPARATUS AND INSTRUMENTS, NAMELY, ELECTRIC FANS, VENTILATING FANS, ELECTRIC AIR PURIFIERS, EXTRACTION HOODS FOR COOKERS, ELECTRIC DEHUMIDIFIERS, ELECTRIC HUMIDIFIERS, BLOWING MACHINES IN THE NATURE OF ELECTRIC EXHAUST FANS, AIR CONDITIONING APPARATUS IN THE NATURE OF AIR CURTAINS, AIR HANDLING UNITS, CEILING FANS, ROOF VENTILATORS, AND PARTS AND FITTINGS THEREFOR, ALL INCLUDED IN THIS CLASS; APPARATUS AND INSTALLATIONS FOR HEATING, STEAM-GENERATING, DRYING, COOLING AND AIR-CONDITIONING, NAMELY, AIR CONDITIONERS, FAN COIL UNITS FOR AIR-CONDITIONING, EVAPORATIVE AIR REFRESHING APPARATUS, GAS AND ELECTRIC STOVES, ELECTRIC SPACE HEATERS, ELECTRIC BLANKETS, ELECTRICALLY HEATED FLOOR CARPETS, KEROSENE FAN HEATERS, ELECTRIC FOOT WARMERS (KOTATSU), GAS CORDLESS ROOM WARMERS; WATER SUPPLY APPARATUS, NAMELY, HOT WATER TANKS; INSTALLATIONS FOR SANITARY PURPOSES IN THE NATURE OF STEAM ROOMS, ELECTRIC BIDETS, TOILETS, WASHING TOILET SEATS, PORTABLE TOILETS, SEWAGE AERATION TREATMENT SYSTEMS, COMPRISED OF FILTERS AND GAS EXTRACTORS, WATER-PURIFIERS, INCINERATORS IN THE NATURE OF TRASH BURNERS, SAUNA BATHS, BATHTUBS, BATH INSTALLATIONS, ELECTRIC HOME SHOWER; WATER HEATERS, GAS INSTANTANEOUS WATER HEATERS; DRYERS, NAMELY, ELECTRIC DISH DRYERS, ELECTRIC HAIR DRYERS, CLOTHES DRYERS; METALLIC SINKS; ELECTRIC LAMPS; DRYERS FOR CLOTHES, ELECTRIC CLOTHES DRYERS (U.S. CLS. 13, 21, 23, 31 AND 34).

CLASS 12—VEHICLES

FOR VEHICLES; APPARATUS FOR LOCOMOTION BY LAND, AIR OR WATER, NAMELY, CARS, BUSES, COACHES, LIGHT LORRIES AND TRUCKS, VANS, MOTOR HOMES, MOTORBIKES, MOPEDS, SCOOTERS, BOATS, SHIPS, AIRPLANES, HELICOPTERS, LOCOMOTIVES, RAILWAY CARS; TIRES FOR VEHICLES; ELECTRIC MOTORS AND DIESEL ENGINES FOR LAND VEHICLES; BICYCLES, BICYCLE TIRES AND TUBES, AUTOMATIC GUIDED VEHICLES, ELECTRIC POWER ASSISTED BICYCLES (U.S. CLS. 19, 21, 23, 31, 35 AND 44).

CLASS 14—JEWELRY

FOR PRECIOUS METALS AND THEIR ALLOYS AND GOODS IN PRECIOUS METALS OR COATED THEREWITH, NAMELY, COMMEMORATIVE COINS AND MEDALS; JEWELRY, PRECIOUS STONES; HOROLOGICAL AND CHRONOMETRIC INSTRUMENTS, LAPEL PINS (U.S. CLS. 2, 27, 28 AND 50).

CLASS 32—LIGHT BEVERAGES

FOR BEERS; MINERAL AND AERATED WATERS AND OTHER NON-ALCOHOLIC DRINKS, NAMELY ALOE VERA DRINKS, COFFEE-FLAVORED SOFT DRINKS, SOFT DRINKS, ENERGY DRINKS, GUARANA DRINKS, ISOTONIC DRINKS, SPORTS DRINKS; FRUIT DRINKS AND FRUIT JUICES; SYRUPS FOR MAKING BEVERAGES AND OTHER PREPARATIONS FOR MAKING SOFT DRINKS, FRUIT DRINKS AND FRUIT JUICES BEVERAGES (U.S. CLS. 45, 46 AND 48).

CLASS 36—INSURANCE AND FINANCIAL

FOR INSURANCE CONSULTATION; FINANCIAL MANAGEMENT; MONETARY EXCHANGE; REAL ESTATE AFFAIRS, NAMELY, REAL ESTATE APPRAISAL, REAL ESTATE INVESTMENT; CREDIT CARD SERVICES; FINANCING OF SPORTING AND CULTURAL ACTIVITIES; RENTAL OF BUILDINGS AND OUTBUILDINGS DESIGNED FOR HOSTING BUSINESS ENTERTAINMENT; ASSET BASED AND PRIVATE LABEL FINANCING SERVICES; FINANCIAL ANALYSIS AND CONSULTATION; CREDIT CARD FINANCIAL SERVICES; CREDIT CARD SERVICES, NAMELY, EXTENSION OF CREDIT TO OTHERS; FINANCIAL ASSET MANAGEMENT FOR OTHERS; INSURANCE AND REINSURANCE SERVICES, NAMELY, UNDERWRITING SERVICES FOR ALL TYPES OF INSURANCE; EQUITY INVESTMENT SERVICES; INSURANCE UNDERWRITING SERVICES IN THE FIELD OF BONDS; FINANCIAL GUARANTEE ASSURANCE UNDERWRITING SERVICES; PERSONAL LOAN FINANCING; MORTGAGE BANKING SERVICES; ACQUISITION FINANCING SERVICES; COMMERCIAL FINANCING SERVICES; COMMERCIAL REAL ESTATE AGENCY SERVICES; MUTUAL FUND INVESTMENT; PRIVATE EQUITY AND DEBT INVESTMENT; CONSULTANCY, ADVISORY AND INFORMATION SERVICES RELATING TO ALL THE FOREGOING SERVICES; LEASING AND RENTAL OF MOBILE AND MODULAR BUILDINGS, INSURANCE BROKERAGE SERVICES, CREDIT AGENCY SERVICES IN THE FIELDS OF CONSUMER AND COMMERCIAL CREDIT, REAL ESTATE LOAN FINANCING SERVICES AND BANKING AND FINANCING SERVICES; COMPUTERIZED SERVICES IN CONNECTION WITH FINANCIAL AND MONETARY OPERATIONS RELATING TO ELECTRONIC COMMERCIAL TRANSACTIONS, NAMELY ELECTRONIC FUNDS TRANSFERS, ELECTRONIC DEBIT AND CREDIT CARD TRANSACTIONS; BANKING, NAMELY, BANK CARD SERVICES AND STORE ACCOUNT CARD SERVICES; FINANCIAL CLEARING-HOUSE SERVICES; ISSUING OF CHEQUES AND LETTERS OF CREDIT; FINANCIAL TRUST OPERATIONS; BILL PAYMENT SERVICES; DEBIT CARD SERVICES; CHARGE CARD SERVICES; PREPAID CARD SERVICES; ELECTRONIC CREDIT AND DEBIT TRANSACTIONS; ELECTRONIC FUNDS TRANSFER; SMART CARD AND ELECTRONIC CASH CARD SERVICES; ELECTRONIC CASH DISBURSEMENTS SERVICES; CASH REPLACEMENT RENDERED BY CREDIT CARD AND DEBIT CARDS; ELECTRONIC CASH TRANSACTIONS; CHEQUE VERIFICATION; CHEQUE CASHING; DEPOSIT ACCESS AND AUTOMATED TELL-

ER MACHINE SERVICES; PAYMENT PROCESSING SERVICES, NAMELY, CREDIT CARD AND DEBIT CARD TRANSACTION PROCESSING SERVICES; PROVIDING FINANCIAL INFORMATION VIA A GLOBAL COMPUTER NETWORK; FINANCIAL SPONSORSHIP OF MUSICAL CONCERTS AND FESTIVALS; INFORMATION SERVICES IN THE TOURIST FIELD, NAMELY, PROVIDING FINANCIAL INFORMATION IN REGARD TO FINANCIAL MATTERS FOR THE ASSISTANCE OF TOURISTS; PROVIDING INFORMATION RELATED TO COMMODITY TRADING (U.S. CLS. 100, 101 AND 102).

CLASS 37—CONSTRUCTION AND REPAIR

FOR BUILDING CONSTRUCTION; REPAIR, INSTALLATION AND MAINTENANCE OF COMPUTER SYSTEMS HARDWARE, COMPUTER NETWORK HARDWARE AND COMPUTER HARDWARE; INSTALLATION, REPAIR, REPLACEMENT, OVERHAUL AND MAINTENANCE OF POWER PLANTS, ENGINES, TURBINES, WIND TURBINES, MOTORS AND APPARATUS, EQUIPMENT AND INSTRUMENT FOR THE GENERATION OF POWER AND ELECTRICITY AND THEIR COMPONENT PARTS, FITTINGS AND ACCESSORIES; INSTALLATION, MAINTENANCE AND REPAIR SERVICES FOR COMPRESSORS AND PUMPS, NAMELY, MACHINE PUMPS AND COMPRESSORS, TURBO EXPANDERS, FUEL PUMPS AND FUEL DISTRIBUTION EQUIPMENT, CNG REFUELING EQUIPMENT, GAS TURBINES, STEAM TURBINES, AIR COOLED HEAT-EXCHANGERS, STEAM CONDENSERS, HEAVY WALL REACTORS AND TUBULAR REACTORS; OIL AND GAS PIPELINE MAINTENANCE AND REPAIR SERVICES; OIL WELL CASING, TUBING AND DRILL PIPE INSTALLATION; DIAGNOSTIC REPAIR AND MAINTENANCE SERVICES RENDERED IN THE REPAIR AND MAINTENANCE OF AIRCRAFT ENGINES, TURBINES, ELECTRICAL EQUIPMENT, MEDICAL EQUIPMENT, LOCOMOTIVES INCLUDING ACCESSORIES AND COMPONENT PARTS OF ALL THE FOREGOING; CHEMICAL CLEANING SERVICES FOR GLASS-LINED REACTOR VESSELS USED IN THE CHEMICAL AND PHARMACEUTICAL PROCESSING INDUSTRIES; MAINTENANCE SERVICES FOR HEAT TRANSFER SYSTEMS AND CONDENSERS; MAINTENANCE AND REPAIR SERVICES IN THE FIELD OF COMPUTERIZED COOLING SYSTEM EQUIPMENT, REPAIR AND MAINTENANCE OF MACHINERY, INSTRUMENTS, ELECTRICAL EQUIPMENT AND APPLIANCES, NAMELY, OIL AND GAS EQUIPMENT MAINTENANCE AND REPAIR SERVICES; INSTALLATION OF POINT OF SALE TERMINALS IN SHOPS; COMPUTER MAINTENANCE; ELECTRIC APPLIANCE INSTALLATION AND REPAIR, REPAIR OF RADIO RECEIVERS AND TELEVISION RECEIVERS, REPAIR AND MAINTENANCE OF ELECTRICAL COMMUNICATION APPARATUS AND INSTRUMENTS, REPAIR AND MAINTENANCE OF HOUSEHOLD ELECTRIC APPLIANCES, REPAIR AND MAINTENANCE OF ELECTRIC LIGHTING APPARATUS, REPAIR AND MAINTENANCE OF POWER DISTRIBUTION AND CONTROL APPARATUS, REPAIR AND MAINTENANCE OF ELECTRIC MOTORS, REPAIR AND MAINTENANCE OF MEASURING AND TESTING MACHINES AND INSTRUMENTS, REPAIR AND MAINTENANCE OF MEDICAL APPARATUS AND INSTRUMENTS, REPAIR AND MAINTENANCE OF METALWORKING MACHINES AND TOOLS, REPAIR AND MAINTENANCE OF COOKING APPLIANCES, REPAIR AND MAINTENANCE OF AUTOMATIC DISTRIBUTION MACHINES, REPAIR AND MAINTENANCE OF WATER PURIFYING APPARATUS, REPAIR AND MAINTENANCE OF MUSICAL INSTRUMENTS, WATCH AND CLOCK REPAIR AND MAINTENANCE, REPAIR AND MAINTENANCE OF GAS WATER HEATERS FOR HOUSEHOLD PURPOSES, REPAIR AND MAINTENANCE OF BATH EQUIPMENT, REPAIR OF TOILET STOOL UNITS WITH WASHING WATER SQUIRTING FEATURES, INSTALLATION, MAINTENANCE AND REPAIR OF COMPUTER HARDWARE, REPAIR AND MAINTENANCE OF AIR CONDITIONING APPARATUS, OFFICE MACHINES AND EQUIPMENT INSTALLATION, MAINTENANCE AND REPAIR, MACHINERY INSTALLATION, MAINTENANCE AND REPAIR, VEHICLE REPAIR, REPAIR AND MAINTENANCE OF ELECTRICAL COMMUNICATION APPARATUS AND INSTRUMENTS, REPAIR AND MAINTENANCE OF COMPUTERS, REPAIR AND MAINTENANCE OF ELECTRONIC PRINTERS, TELEPHONE

REPAIR, REPAIR AND MAINTENANCE OF CONSUMER ELECTRONICS AND TELECOMMUNICATIONS EQUIPMENT (U.S. CLS. 100, 103 AND 106).

CLASS 38—COMMUNICATION

FOR TELECOMMUNICATION SERVICES, NAMELY, LOCAL AND LONG DISTANCE TRANSMISSION OF VOICE, DATA, GRAPHICS BY MEANS OF TELEPHONE, TELEGRAPHIC, CABLE, AND SATELLITE TRANSMISSIONS; TELEVISION BROADCASTING; COMMUNICATIONS BY MOBILE TELEPHONES; COMMUNICATIONS BY ELECTRONIC COMPUTER TERMINALS; PROVIDING ACCESS TO DATABASES AND INTERNET RELATED TELECOMMUNICATIONS NETWORKS; COMMUNICATIONS BY A COMMUNICATIONS SYSTEM CONSISTING OF TELETYPEWRITERS CONNECTED TO A TELEPHONIC NETWORK TO SEND AND RECEIVE SIGNALS; COMMUNICATIONS BY TELEGRAPH; COMMUNICATIONS BY TELEPHONE; COMMUNICATIONS BY FACSIMILE; PAGING BY RADIO; COMMUNICATIONS BY TELECONFERENCING; CABLE TELEVISION BROADCASTING; RADIO BROADCASTING; PRESS AND INFORMATION AGENCY SERVICES, SPECIFICALLY, TRANSMISSION OF NEWS INCLUDING SPORTS RESULTS AND ENTERTAINMENT; OTHER MESSAGE TRANSMISSION SERVICES, SPECIFICALLY, DELIVERY OF MESSAGES BY ELECTRONIC MEANS; BROADCASTING OF A COMMERCIAL SITE ON THE INTERNET; STREAMING OF RADIO AND TELEVISION PROGRAMMING AND BROADCASTING SERVICES PROVIDED VIA THE INTERNET; ELECTRONIC MESSAGING; PROVIDING ACCESS TO COMPUTER BULLETIN BOARDS, AND REAL-TIME CHAT FORUMS FOR TRANSMISSION OF MESSAGES AMONG USERS CONCERNING SPORTS AND ENTERTAINMENT; TRANSMISSION OF MESSAGES AND IMAGES VIA COMPUTER; PROVIDING ACCESS TO TELECOMMUNICATIONS CHANNELS FOR HOME AND OFFICE TELESHOPPING SERVICES VIA COMPUTER AND/OR INTERACTIVE COMMUNICATIONS TECHNOLOGIES; TELECOMMUNICATION OF INFORMATION INCLUDING WEB PAGES, COMPUTER PROGRAMS AND ANY OTHER DATA, SPECIFICALLY, DATA TRANSMITTED BY ELECTRONIC COMMUNICATIONS NETWORK; ELECTRONIC MAIL SERVICES; PROVIDING USER ACCESS TO THE INTERNET; PROVIDING TELECOMMUNICATIONS CONNECTIONS TO THE INTERNET OR DATABASES; PROVIDING ACCESS TO DIGITAL MUSIC WEB SITES ON THE INTERNET; PROVIDING ACCESS TO MP3 WEB SITES ON THE INTERNET; DELIVERY OF DIGITAL MUSIC BY TELECOMMUNICATIONS; RENTAL OF ACCESS TIME TO A CENTRAL DATABASE AVAILABLE ON THE INTERNET; PROVIDING ACCESS TO SEARCH ENGINE DATABASES; MANAGEMENT OF CHAT FORUMS ON THE INTERNET FOR TRANSMISSION OF MESSAGES AMONG COMPUTER USERS CONCERNING SPORTS AND ENTERTAINMENT; RENTAL OF TELECOMMUNICATION LINES FOR ACCESS TIME TO A CENTRAL SERVER DATABASE; RENTAL OF TELECOMMUNICATION LINES FOR ACCESS TIME TO A COMPUTER DATABASE; SIMULTANEOUS BROADCASTING OF FILMS AND OF VIDEO AND SOUNDS RECORDINGS VIA ELECTRONIC COMMUNICATIONS NETWORKS; PROVIDING E-MAIL SERVICES; WIRELESS DATA MESSAGING SERVICE, PARTICULARLY SERVICE THAT ENABLE A USER TO SEND AND/OR RECEIVE MESSAGE THROUGH A WIRELESS DATA WORK; ONE-WAY AND TWO-WAY PAGING SERVICES; ELECTRONIC TRANSMISSION OF DATA, IMAGES, AUDIO, VIDEO AND DOCUMENTS, INCLUDING TEXT, CARDS, LETTERS, MESSAGES, MAIL, ANIMATIONS AND ELECTRONIC MAIL, OVER LOCAL OR GLOBAL COMMUNICATIONS NETWORKS, INCLUDING THE INTERNET, INTRANETS, EXTRANETS, TELEVISION, MOBILE COMMUNICATION, CELLULAR AND SATELLITE NETWORKS; ELECTRONIC TRANSMISSION OF COMPUTER SOFTWARE OVER LOCAL OR GLOBAL COMMUNICATIONS NETWORKS, INCLUDING THE INTERNET, INTRANETS, EXTRANETS, TELEVISION, MOBILE COMMUNICATION, CELLULAR, AND SATELLITE NETWORKS; PROVIDING ACCESS TO DATABASES AND LOCAL OR GLOBAL COMMUNICATIONS NETWORKS, NAMELY THE INTERNET, INTRANETS, EXTRANETS, TELEVISION, MOBILE COMMUNICATION, CELLULAR, AND SATELLITE NETWORKS; MESSAGE TRANSMISSION AND RELAY SERVICES,

NAMELY, ELECTRONIC TRANSMISSION OF MESSAGES; TELECOMMUNICATION SERVICES FOR THE DISSEMINATION OF INFORMATION BY MOBILE TELEPHONE, NAMELY, THE TRANSMISSION OF DATA TO MOBILE TELEPHONES; MOBILE TELEPHONE COMMUNICATION SERVICES; ELECTRONIC TRANSMISSION AND RECEPTION OF VOICE COMMUNICATION; COMMUNICATION SERVICES, NAMELY, TRANSMISSION OF DATA BY TELECOMMUNICATIONS NETWORKS, AND MULTIMEDIA COMMUNICATIONS NETWORKS; RENTAL OF ACCESS TIME TO GLOBAL COMPUTER NETWORKS; TRANSMISSION OF DATA, IMAGES, AUDIO, VIDEO AND DOCUMENTS, INCLUDING TEXT, ELECTRONIC CARDS, LETTERS, MESSAGES, E-MAIL, ANIMATIONS AND ELECTRONIC MAIL, OVER LOCAL OR GLOBAL COMMUNICATIONS NETWORKS, INCLUDING THE INTERNET, INTRANETS, EXTRANETS, TELEVISION, MOBILE COMMUNICATION, CELLULAR AND SATELLITE NETWORKS (U.S. CLS. 100, 101 AND 104).

CLASS 42—SCIENTIFIC AND COMPUTER SERVICES

FOR SCIENTIFIC AND TECHNOLOGICAL SERVICES AND RESEARCH AND DESIGN RELATING THERETO IN THE FIELD OF MEDICAL AND PHARMACO-TOXICOLOGICAL SCIENCE AND TESTING; INDUSTRIAL ANALYSIS AND RESEARCH SERVICES IN THE FIELD OF MEDICAL AND PHARMACO-TOXICOLOGICAL SCIENCE AND TESTING; LABORATORY ANALYSIS IN THE FIELD OF MEDICAL AND PHARMACO-TOXICOLOGICAL SCIENCE AND TESTING; DESIGN AND DEVELOPMENT OF COMPUTER HARDWARE AND SOFTWARE; SERVICES RELATING TO WIND AND WIND POWER, NAMELY, PROFESSIONAL ENGINEERING AND DESIGN CONSULTING SERVICES AND ENGINEERING SERVICES; DESIGN OF NEW PRODUCTS FOR OTHERS IN THE FIELD OF WIND POWER; INDUSTRIAL DESIGN SERVICES; DESIGN OF POWER, WIND POWER AND ELECTRIC POWER GENERATING EQUIPMENT AND INSTALLATIONS; ENGINEERING SERVICES, TECHNICAL CONSULTATION AND SCIENTIFIC RESEARCH SERVICES IN THE OIL AND GAS EXPLORATION INDUSTRIES; OIL AND GAS EXPLORATION SERVICES; GEOPHYSICAL EXPLORATION FOR THE OIL AND GAS INDUSTRIES; ANALYSIS OF OIL AND GAS FIELDS; OIL AND GAS PROSPECTING, NAMELY, WELL LOGGING AND TESTING; OIL AND GAS WELL TESTING; OIL AND GAS PIPELINE INSPECTION; REMOTE MONITORING AND DIAGNOSTIC SERVICES FOR COMPRESSORS, PUMPS, TURBOEXPANDERS, FUEL PUMPS AND FUEL DISTRIBUTION EQUIPMENT, CNG REFUELING EQUIPMENT, GAS TURBINES, STEAM TURBINES, AIR COOLED HEAT EXCHANGERS, STEAM CONDENSERS, HEAVY WALL REACTORS AND TUBULAR REACTORS; PLANNING, DESIGN AND MANAGEMENT OF INFORMATION TECHNOLOGY SYSTEMS IN THE FIELD OF GLOBAL RAILROAD AND TRANSIT INDUSTRIES; CONSULTATION, AND ADVISORY SERVICES RELATING TO ENGINEERING, DESIGN AND DEVELOPMENT PROBLEMS ENCOUNTERED BY UTILITY, INDUSTRIAL, AND COMMERCIAL COMPANIES, GOVERNMENTS, AND INDIVIDUALS; COMPUTER PROGRAMMING SERVICES FOR OTHERS; COMPUTER SOFTWARE DESIGN AND ANALYSIS SERVICES FOR OTHERS; COMPUTER CONSULTATION SERVICES, MAINTENANCE AND UPDATING OF COMPUTER SOFTWARE AND COMPUTER PROGRAMS FOR OTHERS; INSTALLATION OF COMPUTER SOFTWARE; COMPUTER SYSTEMS ANALYSIS AND DESIGN SERVICES FOR OTHERS; CONSULTANCY SERVICES RELATING TO CHEMICAL RESEARCH; CONSULTANCY SERVICES RELATING TO THE DISCOVERY AND EVALUATION OF DRUGS AND COMPOUNDS HAVING DIAGNOSTIC, PROPHYLACTIC AND/OR THERAPEUTIC PROPERTIES; MEDICAL AND SCIENTIFIC RESEARCH CONSULTANCY SERVICES RELATING TO METHODS FOR DIAGNOSIS USING LASER BASED OPTICAL SYSTEMS; DEVELOPMENT AND DESIGN OF HIGH THROUGH PUT SCREENING ASSAYS FOR DRUG DEVELOPMENT SERVICES; RESEARCH AND DEVELOPMENT IN THE BIOTECHNOLOGY FIELD; TECHNICAL SUPPORT SERVICES FOR FACTORY AUTOMATION SOFTWARE, NAMELY, PROVIDING MAINTENANCE OF COMPUTER SOFTWARE AND PROVIDING PERIODIC UPGRADES OF SOFTWARE;

CUSTOM DESIGN OF SECURITY ACCESS SYSTEMS; DESIGN AND CONSULTING SERVICES IN CONNECTION WITH THE CONFIGURATION OF SYSTEMS USED IN APPLICATIONS SUPPORTING FIBER OPTIC TECHNOLOGY; TECHNICAL SUPPORT, NAMELY, MONITORING OF NETWORK SYSTEMS; TECHNICAL CONSULTATION CONCERNING THE DESIGN AND DEVELOPMENT OF SECURITY AND ACCESS SYSTEMS; LABORATORY AND TESTING SERVICES FOR FLUID SEPARATION AND MEMBRANE TESTING; ENGINEERING AND CONSULTING SERVICES FOR THE DETECTION OF CONTAMINANTS IN WATER TREATMENT SYSTEMS, AQUEOUS SYSTEMS, COOLING WATER SYSTEMS, INDUSTRIAL BOILER WATER SYSTEMS, INDUSTRIAL WATER AND PROCESS SYSTEMS, INDUSTRIAL FUEL PROCESSING SYSTEMS, PULP AND PAPER MAKING SYSTEMS, AND METAL AND PLASTIC PROCESSING SYSTEMS; ENGINEERING SERVICES AND TECHNICAL SUPPORT SERVICES, NAMELY, DESIGN AND CONFIGURATION OF COMPUTER SOFTWARE AND HARDWARE SYSTEMS TO BE USED IN THE TREATMENT OF AQUEOUS SYSTEM AND IN THE TREATMENT OF PULP AND PAPER MAKING SYSTEMS, PETROLEUM AND PETROCHEMICAL PROCESSING SYSTEMS, AND METAL AND PLASTIC FINISHING OPERATIONS; PROGRAMMING FOR DATA PROCESSING MACHINES, NAMELY, PROGRAMMING OF ELECTRONIC MONEY MACHINES; RESEARCH AND INDUSTRIAL DEVELOPMENT IN THE FIELD OF COMPUTERS; TECHNICAL CONSULTATION IN THE FIELD OF COMPUTERS; CREATION AND MAINTENANCE OF COMPUTER DATA BASES AND COMPUTER PROGRAMS; HOSTING THE WEB SITES OF OTHERS ON A COMPUTER SERVER FOR A GLOBAL COMPUTER NETWORK; INSTALLATION OF COMPUTER SOFTWARE; MAINTENANCE OF COMPUTER SOFTWARE; PROVIDING SEARCH ENGINES FOR THE INTERNET; RECOVERY OF COMPUTER DATA; PRODUCT RESEARCH AND DEVELOPMENT FOR OTHERS; SURVEYING; UPDATING OF COMPUTER SOFTWARE; MAINTENANCE OF COMPUTER SOFTWARE; ENGINEERING, TESTING AND RESEARCH RELATING TO ELECTRIC MACHINES, APPARATUS AND INSTRUMENTS (U.S. CLS. 100 AND 101).

CLASS 43—HOTEL AND RESTAURANT SERVICES

FOR SERVING FOOD AND DRINKS; RESTAURANT SERVICES; WELCOMING SERVICES, NAMELY PROVIDING FOOD AND DRINK; CATERING SERVICES; BOOKING OF TEMPORARY ACCOMMODATION AND HOTEL ROOMS; BAR SERVICES; CAFÉS; RENTAL OF MEETING ROOMS, NAMELY, RENTAL OF ROOMS FOR SOCIAL FUNCTIONS; TOURIST HOMES; INFORMATION SERVICES IN THE TOURIST FIELD, NAMELY LODGING INFORMATION SERVICES; INFORMATION SERVICES IN THE TOURIST FIELD, NAMELY INFORMATION ON PROVISION OF FOOD AND DRINKS; SERVICES IN REGARD TO LODGING FOR THE ASSISTANCE OF TOURISTS IN THE NATURE OF TRAVEL AGENCY SERVICES, NAMELY, MAKING RESERVATIONS AND BOOKING FOR TEMPORARY LODGING; SERVICES IN REGARD TO PROVISION OF FOOD AND MEALS FOR THE ASSISTANCE OF TOURISTS, NAMELY, RESTAURANT RESERVATION SERVICES; TOURIST RESERVATION SERVICES, NAMELY HOTEL RESERVATION AND FOOD AND MEAL RESERVATION SERVICES; INFORMATION SERVICES IN THE TOURIST FIELD, NAMELY, RESERVATION INFORMATION CONCERNING HOTEL, LODGING, FOOD AND MEALS; TOURIST ASSISTANCE AND RESERVATION SERVICES, NAMELY, MAKING RESERVATIONS FOR HOTELS, LODGING, FOOD AND MEALS (U.S. CLS. 100 AND 101).

JEFFERY COWARD, EXAMINING ATTORNEY

SN 85-273,294. THE NORMAL BAR LLC, LA JOLLA, CA. FILED 3-22-2011.



THE COLOR(S) RED, BLACK, WHITE AND GRAY IS/ARE CLAIMED AS A FEATURE OF THE MARK.

THE MARK CONSISTS OF THE WORDING "THE NORMAL BAR" IN BLACK STYLIZED FONT WHERE THE WORD "THE" APPEARS CENTERED OVER THE LETTER "M" IN THE WORD "NORMAL". THERE IS A GRAY SILHOUETTE OF A WOMAN WITH RED SHOES HOLDING ON TO THE SIDE OF THE LETTER "N" IN THE WORD "NORMAL". THERE IS A RED HANDBAG TO THE LEFT OF THE WOMAN. THERE ARE FOUR BARS WHICH INCREASE IN SIZE FROM LEFT TO RIGHT TO THE RIGHT OF THE WORDING. THE LEFT BAR IS DARK GRAY WITH A BLACK TOP, THE SECOND BAR IS WHITE WITH A GRAY TOP, THE THIRD BAR IS RED WITH A RED TOP AND THE FOURTH BAR IS GRAY WITH A GRAY TOP AND A DARK GRAY RIGHT SIDE. THERE IS A GRAY SILHOUETTE OF A MAN WEARING A RED NECKTIE SITTING ON THE RED BAR. THERE IS A RED HORIZONTAL BAR OUTLINED IN BLACK WHICH EXTENDS FROM THE RIGHT OF THE WOMAN TO THE RIGHT OF BARS.

CLASS 16—PAPER GOODS AND PRINTED MATTER

FOR PRINTED PUBLICATIONS, NAMELY, BOOKS, MAGAZINES, JOURNALS, WORKBOOKS, MANUALS, HAND-OUTS, BROCHURES AND PRINTED SURVEY REPORTS IN THE FIELD OF PERSONAL RELATIONSHIPS, SOCIOLOGY AND PSYCHOLOGY (U.S. CLS. 2, 5, 22, 23, 29, 37, 38 AND 50).

CLASS 41—EDUCATION AND ENTERTAINMENT

FOR EDUCATIONAL SERVICES, NAMELY, INTERACTIVE WEBSITE BASED ONLINE AND LIVE CONFERENCES, SEMINARS, CLASSES, PRESENTATIONS AND SPEAKING LECTURES IN THE FIELD OF PERSONAL RELATIONSHIPS, SOCIOLOGY AND PSYCHOLOGY; PERSONAL COACHING IN THE FIELD OF PERSONAL RELATIONSHIPS, SOCIOLOGY AND PSYCHOLOGY, ANALYZING EDUCATIONAL DATA AND TEST SCORES FOR OTHERS; CONDUCTING SURVEYS FOR EDUCATIONAL RESEARCH (U.S. CLS. 100, 101 AND 107).

TINA BROWN, EXAMINING ATTORNEY

SN 85-275,052. CARTIHEAL (2009) LTD., ARIEL, ISRAEL, FILED 3-23-2011.



OWNER OF ISRAEL REG. NO. 229740, DATED 6-15-2011, EXPIRES 6-15-2021.

THE MARK CONSISTS OF THE WORD "CARTIHEAL" IN STYLIZED SCRIPT WITH AN OVAL SHAPED DESIGNED MADE OF LINES ABOVE THE LETTER "I" IN THE WORDING "CARTIHEAL".

CLASS 5—PHARMACEUTICALS

FOR MEDICAL IMPLANTS, NAMELY, BONE AND CARTILAGE IMPLANTS MADE OF BIOLOGICAL MATERIALS; SPINAL IMPLANTS MADE OF BIOLOGICAL MATERIALS (U.S. CLS. 6, 18, 44, 46, 51 AND 52).

CLASS 10—MEDICAL APPARATUS

FOR SURGICAL, MEDICAL, DENTAL AND VETERINARY APPARATUS AND INSTRUMENTS; ARTIFICIAL LIMBS, EYES AND TEETH; ORTHOPEDIC ARTICLES, NAMELY, BRACES, JOINT IMPLANTS, SHOE INSERTS, WRIST, NECK, BACK, ANKLE, KNEE AND ELBOW SUPPORTERS, PROTECTORS AND SPLINTS, PROSTHESIS; SURGICAL IMPLANTS COMPRISING ARTIFICIAL MATERIAL; MEDICAL IMPLANTS, NAMELY, BONE AND CARTILAGE IMPLANTS MADE OF ARTIFICIAL MATERIALS; SPINAL IMPLANTS MADE OF ARTIFICIAL MATERIALS; SUTURE MATERIALS; PARTS AND ACCESSORIES FOR THE AFOREMENTIONED GOODS (U.S. CLS. 26, 39 AND 44).

SAMUEL E. SHARPER JR., EXAMINING ATTORNEY

SN 85-275,369. SAFEWAY SAFETY STEP, LLC, FAIRFIELD, OH. FILED 3-24-2011.

SAFEWAY SAFETY STEP

THE MARK CONSISTS OF STANDARD CHARACTERS WITHOUT CLAIM TO ANY PARTICULAR FONT, STYLE, SIZE, OR COLOR.

OWNER OF U.S. REG. NO. 2,836,567.

NO CLAIM IS MADE TO THE EXCLUSIVE RIGHT TO USE "SAFETY STEP", APART FROM THE MARK AS SHOWN.

CLASS 11—ENVIRONMENTAL CONTROL APPARATUS

FOR BATHTUB SIDEWALL INSERT AND DOOR TO PERMIT EASE OF ACCESS (U.S. CLS. 13, 21, 23, 31 AND 34).

FIRST USE 1-31-2011; IN COMMERCE 1-31-2011.

CLASS 37—CONSTRUCTION AND REPAIR

FOR BATHTUB SIDEWALL INSERT AND DOOR INSTALLATION SERVICES (U.S. CLS. 100, 103 AND 106).

FIRST USE 1-31-2011; IN COMMERCE 1-31-2011.

TIMOTHY FINNEGAN, EXAMINING ATTORNEY

SN 85-275,397. DBT-CEV SAS, BREBIERES, FRANCE, FILED 3-24-2011.

DBT-USA

THE MARK CONSISTS OF STANDARD CHARACTERS WITHOUT CLAIM TO ANY PARTICULAR FONT, STYLE, SIZE, OR COLOR.

CLASS 9—ELECTRICAL AND SCIENTIFIC APPARATUS

FOR ELECTRIC VEHICLE CHARGING SUPPLY EQUIPMENT, NAMELY, LEVEL I, LEVEL II AND LEVEL III CHARGING STATIONS FOR CHARGING ELECTRIC VEHICLES FOR HOME, PRIVATE AND PUBLIC USE (U.S. CLS. 21, 23, 26, 36 AND 38).

CLASS 37—CONSTRUCTION AND REPAIR

FOR INSTALLATION SERVICES, REPAIR AND MAINTENANCE OF ELECTRIC VEHICLE SUPPLY EQUIPMENT (EVSE), NAMELY, INSTALLATION, MAINTENANCE AND REPAIR OF ELECTRIC COUPLINGS, CHARGERS FOR ELECTRIC VEHICLE BATTERIES, SUPPLY TERMINALS FOR ELECTRIC VEHICLES (EVSE), POWER DISTRIBUTION PANELS, AND ELECTRICAL CONNECTION BOXES FOR OTHERS; INSTALLATION, MAINTENANCE AND REPAIR OF ELECTRIC VEHICLE CHARGING STATIONS AND JUNCTION BOXES FOR OTHERS; INSTALLATION OF WIRING AND POWER SUPPLY EQUIPMENT FOR TRANSMISSION AND DISTRIBUTION OF ELECTRICITY FOR USE IN ELECTRIC VEHICLE CHARGING STATIONS (U.S. CLS. 100, 103 AND 106).

CLASS 42—SCIENTIFIC AND COMPUTER SERVICES

FOR PROVIDING AN ON-LINE SEARCHABLE DATABASE FEATURING ELECTRIC METER READING AND DATA ANALYSIS WITH RESPECT TO ELECTRIC VEHICLE CHARGING STATION USAGE AND THE NUMBER OF ELECTRIC VEHICLE CHARGING SESSIONS FOR USE BY CHARGING INFRASTRUCTURE SUPERVISORS FOR REMOTE ACCESS AND MAINTENANCE PURPOSES; CONSTRUCTION OF COMPATIBILITY TESTS IN THE NATURE OF TESTING, ANALYSIS, AND EVALUATION OF ELECTRIC VEHICLE CHARGING SYSTEMS WITH RESPECT TO LOCAL ELECTRIC GRID TECHNICAL REQUIREMENTS, POWER CONFIGURATION REQUIREMENTS AND INSTALLATION REQUIREMENTS TO ASSURE COMPLIANCE WITH INDUSTRY STANDARDS (U.S. CLS. 100 AND 101).

MICHAEL TANNER, EXAMINING ATTORNEY

SN 85-277,925. ASERIE, MARCUS L, DBA ZIPETEEZ LIMITED, LAKE SUCCESS, NY. FILED 3-26-2011.

ZIPETEEZ

THE MARK CONSISTS OF STANDARD CHARACTERS WITHOUT CLAIM TO ANY PARTICULAR FONT, STYLE, SIZE, OR COLOR.

CLASS 16—PAPER GOODS AND PRINTED MATTER

FOR ADDRESS BOOKS; ALMANACS; APPLIQUES IN THE FORM OF DECALS; APPOINTMENT BOOKS; ART PRINTS; ARTS AND CRAFT PAINT KITS; AUTOGRAPH BOOKS; BABY BOOKS; BALL POINT PENS; BASEBALL CARDS; BINDERS; BOOKENDS; BOOKMARKS; A SERIES OF FICTION BOOKS; BOOKS, MAGAZINES, NEWSLETTERS AND PRINTED PERIODICALS FEATURING INFORMATION ABOUT THEME PARK ATTRACTIONS AND STORIES, GAMES AND ACTIVITIES FOR CHILDREN; BUMPER STICKERS; CALENDARS; CARTOON STRIPS; CHRISTMAS CARDS; CHALK; CHILDREN'S ACTIVITY BOOKS; COASTERS MADE OF PAPER; COIN ALBUMS; COLORING BOOKS; COLOR PENCILS; COMIC BOOKS; COMIC STRIPS; COUPON BOOKS; DECALS; DECORATIVE PAPER CENTERPIECES; DIARIES; DISPOSABLE DIAPERS FOR BABIES; DRAWING RULERS; ENVELOPES; ERASERS; FELT PENS; FLASH CARDS; GIFT CARDS; GIFT WRAPPING PAPER; GREETING CARDS; GUEST BOOKS; MEMO PADS; MODELING CLAY; NEWSPAPERS; NOTE PAPER; NOTEBOOKS; NOTEBOOK PAPER; PAINTINGS; PAPER FLAGS; PAPER PARTY FAVORS; PAPER CAKE DECORATIONS; PAPER PARTY DECORATIONS; PAPER NAPKINS; PAPER PARTY BAGS; PAPERWEIGHTS; PAPER GIFT WRAP BOWS; PAPER PENNANTS; PAPER PLACE MATS; PAPER TABLE CLOTHS; PEN AND PENCIL HOLDERS; PENCILS; PENCIL SHARPENERS; PEN AND PENCIL CASES AND BOXES; PENS; PHOTOGRAPH ALBUMS; PHOTOGRAPHS; PHOTO-ENGRAVINGS; PICTORIAL PRINTS; PICTURE BOOKS; PORTRAITS; POSTCARDS; POSTERS; PRINTED AWARDS; PRINTED CERTIFICATES; PRINTED INVITATIONS; PRINTED MENUS; RECIPE BOOKS; RUBBER STAMPS; SCORE CARDS; STAMP ALBUMS; STATIONERY; STAPLERS; STICKERS; TRADING CARDS; UNGRADUATED RULERS; WRITING PAPER; WRITING IMPLEMENTS (U.S. CLS. 2, 5, 22, 23, 29, 37, 38 AND 50).

CLASS 41—EDUCATION AND ENTERTAINMENT

FOR PRODUCTION, PRESENTATION, DISTRIBUTION AND RENTAL OF MOTION PICTURE FILMS; PRODUCTION, PRESENTATION, DISTRIBUTION AND RENTAL OF TELEVISION AND RADIO PROGRAMS; PRODUCTION, PRESENTATION, DISTRIBUTION AND RENTAL OF SOUND AND VIDEO RECORDINGS; ENTERTAINMENT INFORMATION; PRODUCTION OF ENTERTAINMENT SHOWS AND INTERACTIVE PROGRAMS IN THE FIELD OF CHILDREN'S ENTERTAINMENT FOR DISTRIBUTION VIA TELEVISION, CABLE, SATELLITE, AUDIO AND VIDEO MEDIA, CARTRIDGES, LASER DISCS, COMPUTER DISCS AND ELECTRONIC MEANS; PRODUCTION AND PROVISION OF ENTERTAINMENT, NAMELY, CHILDREN'S ENTERTAINMENT IN THE NATURE OF AN ONGOING TELEVISION SERIES AND CURRENT EVENT NEWS AND INFORMATION VIA COMMUNICATION AND GLOBAL COMPUTER NETWORKS; AMUSEMENT PARK AND THEME PARK SERVICES; EDUCATIONAL AND ENTERTAINMENT SERVICES RENDERED IN OR RELATING TO THEME PARKS IN THE NATURE OF LIVE STAGE SHOWS; PRESENTATION OF LIVE PERFORMANCES IN THE NATURE OF LIVE DANCE AND MUSICAL PERFORMANCES; ENTERTAINMENT IN THE NATURE OF THEATER PRODUCTIONS; ENTERTAINER SERVICES, NAMELY, LIVE, TELEVISED AND MOVIE APPEARANCES BY A PROFESSIONAL ENTERTAINER; ON-LINE ENTERTAINMENT SERVICES, NAMELY, PROVIDING ON-LINE COMPUTER GAMES (U.S. CLS. 100, 101 AND 107).

Laurie Kaufman, Examining Attorney

SN 85-278,100. JEAN WATSON, LLC, BOULDER, CO. FILED 3-27-2011.

Jean Watson Touchstones**CLASS 28—TOYS AND SPORTING GOODS**

FOR TOYS, GAMES AND PLAYTHINGS, NAMELY, BOARD GAMES; ELECTRONIC GAME EQUIPMENT FOR PLAYING VIDEO GAMES, NAMELY, HAND HELD UNITS FOR PLAYING VIDEO GAMES OTHER THAN THOSE ADAPTED FOR USE WITH AN EXTERNAL DISPLAY SCREEN OR MONITOR; GAME CARDS; NON ELECTRIC HAND-HELD SKILL GAMES, SOFT DOLLS, NOT FOR ANIMALS; PUZZLES; TOY ACTION FIGURES, NOT FOR ANIMALS; BALLOONS AND YOYOS; PLUSH TOYS, NOT FOR ANIMALS; CHRISTMAS TREE DECORATIONS; TOY FIGURES ATTACHABLE TO PENCILS; PLUSH TOYS THAT CONNECT TO BELTS BY A HOOK; NON-ARTICULATED TOY PVC FIGURES; AND RUBBER BALLS; GYMNASTIC AND SPORTING ARTICLES EXCEPT CLOTHING, NAMELY, HEAVY DUTY PLAYGROUND EQUIPMENT, NAMELY, PLAY STRUCTURES, CLIMBING UNITS, SLIDES AND SLIDING POLES, SWINGS, SWING SETS, SEE SAWS, JUNGLE GYMS, ROCKING RIDING TOYS, CAROUSELS, PLATFORMS AND ROOFS, HANDRAILS, PLAY STAIRS AND STEPS, BRIDGES, TURNING BARS, STEERING WHEELS, BARRIERS, SHAPED SEATS, FREE STANDING PLAY ENCLOSURES, FREE STANDING PLAY STRUCTURES, TUNNEL AND TUBE UNITS, PLAY PANELS, LADDERS, TUNNEL STRUCTURES IN THE FORM OF CAPSULES, BALANCE BEAMS, AND PARALLEL BARS; HAND-HELD UNITS FOR PLAYING ELECTRONIC GAMES OTHER THAN THOSE ADAPTED FOR USE WITH AN EXTERNAL DISPLAY SCREEN OR MONITOR; CHRISTMAS STOCKINGS; CHRISTMAS TREE ORNAMENTS AND DECORATIONS; SNOW GLOBES (U.S. CLS. 22, 23, 38 AND 50).

THE MARK CONSISTS OF STANDARD CHARACTERS WITHOUT CLAIM TO ANY PARTICULAR FONT, STYLE, SIZE, OR COLOR.

THE NAME(S), PORTRAIT(S), AND/OR SIGNATURE(S) SHOWN IN THE MARK IDENTIFIES "JEAN WATSON", WHOSE CONSENT(S) TO REGISTER IS MADE OF RECORD.

CLASS 10—MEDICAL APPARATUS

FOR MEDICAL TREATMENT APPAREL; MEDICAL WEARING APPAREL, NAMELY, CAPS; MEDICAL WEARING APPAREL, NAMELY, SCRUB PANTS; MEDICAL WEARING APPAREL, NAMELY, SCRUB TOPS; MEDICAL WEARING APPAREL, NAMELY, SHOES; OPERATING ROOM APPAREL (U.S. CLS. 26, 39 AND 44).

FIRST USE 4-14-2011; IN COMMERCE 4-14-2011.

CLASS 25—CLOTHING

FOR NURSE'S APPAREL FOR NON-MEDICAL USE, NAMELY, TOPS AND PANTS, BLOUSES, DRESSES AND SKIRTS (U.S. CLS. 22 AND 39).

FIRST USE 4-14-2011; IN COMMERCE 4-14-2011.
ANGELA M. MICHELI, EXAMINING ATTORNEY

SN 85-279,857. SWEDISH LORRY PARTS AB, TULLINGE, SWEDEN, FILED 3-29-2011.

SN 85-280,220. SWEDISH LORRY PARTS AB, TULLINGE, SWEDEN, FILED 3-29-2011.



THE COLOR(S) BLUE AND YELLOW IS/ARE CLAIMED AS A FEATURE OF THE MARK.

THE MARK CONSISTS OF THE YELLOW LETTERS "S", "L" AND "P" ENCLOSED IN A BLUE SHIELD DESIGN OUTLINED IN YELLOW.

CLASS 7—MACHINERY

FOR STRUCTURAL REPLACEMENT PARTS FOR EARTH MOVING MACHINES, NAMELY, LOADERS, EXCAVATORS, BACKHOE LOADERS AND FOR MARINE AND INDUSTRIAL ENGINES (U.S. CLS. 13, 19, 21, 23, 31, 34 AND 35).

FIRST USE 1-1-1991; IN COMMERCE 1-1-1991.

CLASS 12—VEHICLES

FOR STRUCTURAL REPLACEMENT PARTS FOR HEAVY VEHICLES, NAMELY, TRUCKS, ARTICULATED TRUCKS, AND BUSES (U.S. CLS. 19, 21, 23, 31, 35 AND 44).

FIRST USE 1-1-1991; IN COMMERCE 1-1-1991.

CLASS 35—ADVERTISING AND BUSINESS

FOR DISTRIBUTORSHIPS IN THE FIELD OF REPLACEMENT PARTS FOR HEAVY VEHICLES, NAMELY, TRUCKS, BUSES, WHEEL LOADERS, ARTICULATED HAULERS, EXCAVATORS, BACKHOE LOADERS AND MARINE AND INDUSTRIAL ENGINES (U.S. CLS. 100, 101 AND 102).

FIRST USE 1-1-1991; IN COMMERCE 1-1-1991.

CLASS 39—TRANSPORTATION AND STORAGE

FOR WAREHOUSING SERVICES, NAMELY, STORAGE, DISTRIBUTION, PICK-UP, PACKING, AND SHIPPING OF REPLACEMENT PARTS SUITABLE FOR HEAVY VEHICLES, NAMELY, TRUCKS, BUSES, WHEEL LOADERS, ARTICULATED HAULERS, EXCAVATORS, BACKHOE LOADERS AND MARINE AND INDUSTRIAL ENGINES (U.S. CLS. 100 AND 105).

FIRST USE 1-1-1991; IN COMMERCE 1-1-1991.

TIMOTHY FINNEGAN, EXAMINING ATTORNEY

SLP

THE MARK CONSISTS OF STANDARD CHARACTERS WITHOUT CLAIM TO ANY PARTICULAR FONT, STYLE, SIZE, OR COLOR.

CLASS 7—MACHINERY

FOR STRUCTURAL REPLACEMENT PARTS FOR EARTH MOVING MACHINES, NAMELY, LOADERS, EXCAVATORS, BACKHOE LOADERS AND FOR MARINE AND INDUSTRIAL ENGINES (U.S. CLS. 13, 19, 21, 23, 31, 34 AND 35).

FIRST USE 1-1-1991; IN COMMERCE 1-1-1991.

CLASS 12—VEHICLES

FOR STRUCTURAL REPLACEMENT PARTS FOR HEAVY VEHICLES, NAMELY, TRUCKS, ARTICULATED TRUCKS, AND BUSES (U.S. CLS. 19, 21, 23, 31, 35 AND 44).

FIRST USE 1-1-1991; IN COMMERCE 1-1-1991.

CLASS 35—ADVERTISING AND BUSINESS

FOR DISTRIBUTORSHIPS IN THE FIELD OF REPLACEMENT PARTS FOR HEAVY VEHICLES, NAMELY, TRUCKS, BUSES, WHEEL LOADERS, ARTICULATED HAULERS, EXCAVATORS, BACKHOE LOADERS AND MARINE AND INDUSTRIAL ENGINES (U.S. CLS. 100, 101 AND 102).

FIRST USE 1-1-1991; IN COMMERCE 1-1-1991.

CLASS 39—TRANSPORTATION AND STORAGE

FOR WAREHOUSING SERVICES, NAMELY, STORAGE, DISTRIBUTION, PICK-UP, PACKING, AND SHIPPING OF REPLACEMENT PARTS SUITABLE FOR HEAVY VEHICLES, NAMELY, TRUCKS, BUSES, WHEEL LOADERS, ARTICULATED HAULERS, EXCAVATORS, BACKHOE LOADERS AND MARINE AND INDUSTRIAL ENGINES (U.S. CLS. 100 AND 105).

FIRST USE 1-1-1991; IN COMMERCE 1-1-1991.

TIMOTHY FINNEGAN, EXAMINING ATTORNEY

SN 85-280,309. SWEDISH LORRY PARTS AB, TULLINGE, SWEDEN, FILED 3-29-2011.

SWEDISH LORRY PARTS

THE MARK CONSISTS OF STANDARD CHARACTERS WITHOUT CLAIM TO ANY PARTICULAR FONT, STYLE, SIZE, OR COLOR.

NO CLAIM IS MADE TO THE EXCLUSIVE RIGHT TO USE "LORRY PARTS", APART FROM THE MARK AS SHOWN.

SEC. 2(F).

CLASS 7—MACHINERY

FOR STRUCTURAL REPLACEMENT PARTS FOR EARTH MOVING MACHINES, NAMELY, LOADERS, EXCAVATORS, BACKHOE LOADERS AND FOR MARINE AND INDUSTRIAL ENGINES (U.S. CLS. 13, 19, 21, 23, 31, 34 AND 35).

FIRST USE 1-1-1991; IN COMMERCE 1-1-1991.

CLASS 12—VEHICLES

FOR STRUCTURAL REPLACEMENT PARTS FOR HEAVY VEHICLES, NAMELY, TRUCKS, ARTICULATED TRUCKS, AND BUSES (U.S. CLS. 19, 21, 23, 31, 35 AND 44).

FIRST USE 1-1-1991; IN COMMERCE 1-1-1991.

CLASS 35—ADVERTISING AND BUSINESS

FOR DISTRIBUTORSHIPS IN THE FIELD OF REPLACEMENT PARTS FOR HEAVY VEHICLES, NAMELY, TRUCKS, BUSES, WHEEL LOADERS, ARTICULATED HAULERS, EXCAVATORS, BACKHOE LOADERS AND MARINE AND INDUSTRIAL ENGINES (U.S. CLS. 100, 101 AND 102).

FIRST USE 1-1-1991; IN COMMERCE 1-1-1991.

CLASS 39—TRANSPORTATION AND STORAGE

FOR WAREHOUSING SERVICES, NAMELY, STORAGE, DISTRIBUTION, PICK-UP, PACKING, AND SHIPPING OF REPLACEMENT PARTS SUITABLE FOR HEAVY VEHICLES, NAMELY, TRUCKS, BUSES, WHEEL LOADERS, ARTICULATED HAULERS, EXCAVATORS, BACKHOE LOADERS AND MARINE AND INDUSTRIAL ENGINES (U.S. CLS. 100 AND 105).

FIRST USE 1-1-1991; IN COMMERCE 1-1-1991.
TIMOTHY FINNEGAN, EXAMINING ATTORNEY

SN 85-280,707. HERITAGE SNACKS & FOOD CO.,LTD., KRATUMLOM, SAMPRAN, THAILAND, FILED 3-30-2011.

NUT WALKER

THE MARK CONSISTS OF STANDARD CHARACTERS WITHOUT CLAIM TO ANY PARTICULAR FONT, STYLE, SIZE, OR COLOR.

NO CLAIM IS MADE TO THE EXCLUSIVE RIGHT TO USE "NUT", APART FROM THE MARK AS SHOWN.

CLASS 29—MEATS AND PROCESSED FOODS

FOR SNACKS, NAMELY, DRIED, ROASTED, SALTED, AND SWEETENED NUTS; DRIED SOYBEANS, PROCESSED WATERMELON SEEDS AND PROCESSED PINE NUTS, PISTACHIO NUTS, MACADAMIA NUTS, CASHEW NUTS, PECAN NUTS, HAZEL NUTS AND ALMOND NUTS; PROCESSED FRUITS AND DRIED FRUITS; DRIED BEANS, PROCESSED PEAS (U.S. CL. 46).

FIRST USE 4-8-1992; IN COMMERCE 4-8-1992.

CLASS 30—STAPLE FOODS

FOR SNACKS, NAMELY, POPPED POPCORN; READY TO EAT PROCESSED FOODS, NAMELY, CRACKERS, PRETZELS, POPCORN, NAMELY, MICROWAVE POPCORN, POPPED POPCORN, PROCESSED UNPOPPED POPCORN, RICE, PROCESSED WHEAT AND PROCESSED CORN SNACKS, CANDY NUTS, NAMELY, CHOCOLATE-COVERED NUTS, CANDY, CHOCOLATE, CAKES AND BISCUITS, PROCESSED WHEAT CEREALS, PROCESSED RICE CEREALS, AND PROCESSED CORN CEREALS (U.S. CL. 46).

FIRST USE 4-8-1992; IN COMMERCE 4-8-1992.
WILLIAM VERHOSEK, EXAMINING ATTORNEY

SN 85-284,562. AGILE COMMUNICATION SYSTEMS, LLC, MORGAN HILL, CA. FILED 4-2-2011.

AGILE MILCOMS

THE MARK CONSISTS OF STANDARD CHARACTERS WITHOUT CLAIM TO ANY PARTICULAR FONT, STYLE, SIZE, OR COLOR.

NO CLAIM IS MADE TO THE EXCLUSIVE RIGHT TO USE "MILCOMS", APART FROM THE MARK AS SHOWN.

CLASS 37—CONSTRUCTION AND REPAIR

FOR MAINTENANCE SERVICES FOR MICROWAVE AND SATELLITE SYSTEMS, MICROWAVE AND SATELLITE GROUND STATION TERMINALS, AND REMOTE MICROWAVE AND SATELLITE COMMUNICATION TERMINALS (U.S. CLS. 100, 103 AND 106).

FIRST USE 11-12-2002; IN COMMERCE 11-12-2002.

CLASS 42—SCIENTIFIC AND COMPUTER SERVICES

FOR DESIGN AND IMPLEMENTATION OF MICROWAVE AND SATELLITE SYSTEMS, MICROWAVE AND SATELLITE GROUND STATION TERMINALS, AND REMOTE MICROWAVE AND SATELLITE COMMUNICATION TERMINALS (U.S. CLS. 100 AND 101).

FIRST USE 11-12-2002; IN COMMERCE 11-12-2002.
BRIAN PINO, EXAMINING ATTORNEY

SN 85-285,551. THRIFTY, INC., TULSA, OK. FILED 4-4-2011.



NO CLAIM IS MADE TO THE EXCLUSIVE RIGHT TO USE "TRY IT BEFORE YOU BUY IT", APART FROM THE MARK AS SHOWN.

THE MARK CONSISTS OF THE WORDING "TRY IT" CONTAINED WITHIN A CIRCLE TO THE LEFT OF AN EXCLAMATION POINT THAT HAS THE WORDING "BEFORE YOU BUY IT" CONTAINED WITHIN THE POINT OF THE EXCLAMATION POINT.

CLASS 35—ADVERTISING AND BUSINESS

FOR AUTOMOBILE DEALERSHIPS (U.S. CLS. 100, 101 AND 102).
FIRST USE 6-15-2010; IN COMMERCE 6-15-2010.

CLASS 39—TRANSPORTATION AND STORAGE

FOR LEASING OF AUTOMOBILES; LEASING OF MOTOR VEHICLES; RENTAL OF MOTOR VEHICLES (U.S. CLS. 100 AND 105).
FIRST USE 6-15-2010; IN COMMERCE 6-15-2010.
RUDY R. SINGLETON, EXAMINING ATTORNEY

SN 85-285,732. BIG OUTDOOR WORLD, LLC, CLARKSBURG, WV. FILED 4-4-2011.

BOWNAFIDE

THE MARK CONSISTS OF STANDARD CHARACTERS WITHOUT CLAIM TO ANY PARTICULAR FONT, STYLE, SIZE, OR COLOR.

CLASS 25—CLOTHING

FOR HUNTING AND OUTDOOR APPAREL, NAMELY, JACKETS, SHIRTS, HATS, PANTS, SWEATSHIRTS, AND VESTS, ALL OF WHICH ARE DESIGNED WITH AN ARCHERY OR BOWHUNTING-RELATED THEME (U.S. CLS. 22 AND 39).

CLASS 28—TOYS AND SPORTING GOODS

FOR ARCHERY ACCESSORIES, NAMELY, BROADHEADS, ARROW SHAFTS, AND FLETCHINGS (U.S. CLS. 22, 23, 38 AND 50).

CLASS 41—EDUCATION AND ENTERTAINMENT

FOR ENTERTAINMENT SERVICES, NAMELY, PRODUCTION OF VIDEOS AND TELEVISION SHOWS IN THE FIELDS OF ARCHERY AND ARCHERY-RELATED OUTDOOR ACTIVITIES (U.S. CLS. 100, 101 AND 107).
MARIA-VICTORIA SUAREZ, EXAMINING ATTORNEY

SN 85-286,831. PIZZA HUT, INC., PLANO, TX. FILED 4-5-2011.

SERVING WINGS. SAVING TREES.

THE MARK CONSISTS OF STANDARD CHARACTERS WITHOUT CLAIM TO ANY PARTICULAR FONT, STYLE, SIZE, OR COLOR.

NO CLAIM IS MADE TO THE EXCLUSIVE RIGHT TO USE "SERVING WINGS", APART FROM THE MARK AS SHOWN.

CLASS 16—PAPER GOODS AND PRINTED MATTER

FOR BOXES, CARTONS, STORAGE CONTAINERS, AND PACKAGING CONTAINERS MADE OF PAPER OR CARDBOARD (U.S. CLS. 2, 5, 22, 23, 29, 37, 38 AND 50).

CLASS 29—MEATS AND PROCESSED FOODS

FOR COOKED AND PREPARED CHICKEN (U.S. CL. 46).

CLASS 39—TRANSPORTATION AND STORAGE

FOR PIZZA, COOKED PASTA AND COOKED CHICKEN DELIVERY SERVICES (U.S. CLS. 100 AND 105).

CLASS 43—HOTEL AND RESTAURANT SERVICES

FOR RESTAURANT SERVICES (U.S. CLS. 100 AND 101).
MICHAEL KEATING, EXAMINING ATTORNEY

SN 85-286,837. PIZZA HUT, INC., PLANO, TX. FILED 4-5-2011.

SERVING PASTAS. SAVING TREES.

THE MARK CONSISTS OF STANDARD CHARACTERS WITHOUT CLAIM TO ANY PARTICULAR FONT, STYLE, SIZE, OR COLOR.

NO CLAIM IS MADE TO THE EXCLUSIVE RIGHT TO USE "SERVING PASTAS", APART FROM THE MARK AS SHOWN.

CLASS 16—PAPER GOODS AND PRINTED MATTER

FOR BOXES, CARTONS, STORAGE CONTAINERS, AND PACKAGING CONTAINERS MADE OF PAPER OR CARDBOARD (U.S. CLS. 2, 5, 22, 23, 29, 37, 38 AND 50).

CLASS 30—STAPLE FOODS

FOR PIZZA; PREPARED PASTA ENTREES (U.S. CL. 46).

CLASS 39—TRANSPORTATION AND STORAGE

FOR PIZZA, COOKED PASTA AND COOKED CHICKEN DELIVERY SERVICES (U.S. CLS. 100 AND 105).

CLASS 43—HOTEL AND RESTAURANT SERVICES

FOR RESTAURANT SERVICES (U.S. CLS. 100 AND 101).
MICHAEL KEATING, EXAMINING ATTORNEY

SN 85-287,563. BOSTON AND MAINE CORPORATION, BILLERICA, MA. FILED 4-6-2011.



NO CLAIM IS MADE TO THE EXCLUSIVE RIGHT TO USE "BOSTON AND MAINE", APART FROM THE MARK AS SHOWN.

THE MARK CONSISTS OF A ROUNDED BOTTOM AND A BANNER SHAPED TOP AND CONTAINS THE WORDS "BOSTON AND MAINE" AND AN ILLUSTRATION OF A REVOLUTIONARY MINUTEMAN. THE MINUTEMAN IS IN THE BOTTOM CENTER OF THE ROUNDED LOGO. A DRAPED BANNER RUNS ACROSS THE TOP, ABOVE THE MINUTEMAN WITH THE WORDS "BOSTON AND MAINE".

CLASS 25—CLOTHING

FOR SWEATSHIRTS, SHIRTS, HATS, HEADWEAR (U.S. CLS. 22 AND 39).

FIRST USE 12-1-2007; IN COMMERCE 12-1-2007.

CLASS 28—TOYS AND SPORTING GOODS

FOR TOY MODEL VEHICLES, TOY MODEL TRAINS, TOY MODEL TRAIN CARS, SCALE MODEL VEHICLES, SCALE MODEL TRAINS, SCALE MODEL TRAIN CARS (U.S. CLS. 22, 23, 38 AND 50).

BRIDGETT SMITH, EXAMINING ATTORNEY

SN 85-287,680. PHOTOCOLORZ INC., THOROLD, ONTARIO, CANADA, FILED 4-6-2011.

PHOTOCOLORZ

THE MARK CONSISTS OF STANDARD CHARACTERS WITHOUT CLAIM TO ANY PARTICULAR FONT, STYLE, SIZE, OR COLOR.

CLASS 9—ELECTRICAL AND SCIENTIFIC APPARATUS

FOR COMPUTER SOFTWARE FOR PROCESSING DIGITAL IMAGES; COMPUTER SOFTWARE FOR PROCESSING DIGITAL IMAGES THAT COVERTS DIGITAL PHOTOGRAPHS INTO COLOURABLE IMAGE OUTLINES WITH CAPABILITIES OF VIEWING, MANIPULATING, EDITING, MANAGING, ORGANIZING, AND PRINTING DIGITAL PHOTOGRAPHS; IMAGE CONVERSION SOFTWARE THAT CONVERTS DIGITAL PHOTOGRAPHS INTO COLOURABLE IMAGE OUTLINES, WITH CAPABILITIES OF VIEWING, MANIPULATING, EDITING, MANAGING, ORGANIZING, AND PRINTING DIGITAL PHOTOGRAPHS (U.S. CLS. 21, 23, 26, 36 AND 38).

FIRST USE 2-27-2010; IN COMMERCE 2-27-2010.

CLASS 16—PAPER GOODS AND PRINTED MATTER

FOR COLOURING BOOKS AND COLOURING BOOK SUPPLIES, NAMELY, COIL BINDING READY, PRINTABLE PAPER AND COVERS, SPIRAL PLASTIC BINDING COILS, CRAYONS (U.S. CLS. 2, 5, 22, 23, 29, 37, 38 AND 50).

FIRST USE 2-27-2010; IN COMMERCE 2-27-2010.
CHRISTINE COOPER, EXAMINING ATTORNEY

SN 85-287,730. KROMEK LIMITED, SEDGFIELD, UNITED KINGDOM, FILED 4-6-2011.

KROMEK ENABLED

THE MARK CONSISTS OF STANDARD CHARACTERS WITHOUT CLAIM TO ANY PARTICULAR FONT, STYLE, SIZE, OR COLOR.

PRIORITY CLAIMED UNDER SEC. 44(D) ON ERPN CMNTY TM OFC APPLICATION NO. 009869173, FILED 4-5-2011, REG. NO. 009869173, DATED 9-8-2011, EXPIRES 4-5-2021.

OWNER OF U.S. REG. NO. 3,930,541.

CLASS 1—CHEMICALS

FOR CHEMICALS FOR INDUSTRIAL USE; CADMIUM TELLURIDE CRYSTALS FOR INDUSTRIAL USE; CADMIUM TELLURIDE CRYSTALS; CADMIUM ZINC TELLURIDE CRYSTALS; RADIOGRAPHIC MATERIALS FOR USE IN IMAGING PROCESSES, NAMELY, CRYSTALS AND CHEMICALS FOR INDUSTRIAL USE; IMAGING MATERIALS, NAMELY, CRYSTALS AND CHEMICALS FOR INDUSTRIAL IMAGING USE; CRYSTALS FOR USE IN RADIATION DETECTION; CHEMICALS FOR USE IN SEMICONDUCTOR MANUFACTURE (U.S. CLS. 1, 5, 6, 10, 26 AND 46).

CLASS 9—ELECTRICAL AND SCIENTIFIC APPARATUS

FOR APPARATUS FOR RECORDING, TRANSMISSIONS OR REPRODUCTION OF IMAGES; DATA PROCESSING EQUIPMENT AND COMPUTERS; COMPUTER SOFTWARE FOR IMAGE ENHANCEMENT, IMAGE PROCESSING, SIGNAL PROCESSING AND DATABASE MANAGEMENT IN THE FIELDS OF SPECTROGRAPHY, X-RAY, GAMMA RAY AND NUCLEAR IMAGING; IMAGING APPARATUS AND INSTALLATIONS, NAMELY, X-RAY, GAMMA RAY AND NUCLEAR IMAGING APPARATUS AND DETECTORS FOR NON-MEDICAL USES; IMAGE SCANNERS; X-RAY ANALYZERS, SCANNERS AND IMAGING APPARATUS OTHER THAN FOR MEDICAL USE, NAMELY, APPARATUS FOR USE IN THE INSPECTION OF BAGGAGE, BEVERAGES, FOODSTUFFS, TOILETRIES, COSMETICS, ELECTRONIC ASSEMBLIES AND CONTAINERS BY MEANS OF X-RAYS AND APPARATUS FOR THE DETECTION OF NARCOTICS AND COUNTERFEIT GOODS; APPARATUS FOR USE IN THE INSPECTION OF BAGGAGE BY MEANS OF X-RAYS; APPARATUS FOR THE DETECTION OF EXPLOSIVES, NAMELY, NON-MEDICAL X-RAY ANALYZERS, SCANNERS AND IMAGING APPARATUS; CHROMATIC IMAGING DETECTORS; SEMICONDUCTORS AND SEMICONDUCTOR CHIPS; RADIOGRAPHIC APPARATUS, NAMELY, COMPUTED TOMOGRAPHY SCANNERS NOT FOR MEDICAL USE; LABORATORY EQUIPMENT, NAMELY, SPECTROSCOPIC APPARATUS; X-RAY SPECTROSCOPIC APPARATUS AND INSTRUMENTS FOR NON-MEDICAL USES; SPECTROGRAPHIC APPARATUS AND INSTRUMENTS; SCIENTIFIC APPARATUS, NAMELY, SPECTROMETERS; SPECTRAL IMAGING DETECTORS FOR NON-MEDICAL USES; COMPUTER OPERATING SOFTWARE FOR USE WITH X-RAY, SCANNING AND

IMAGING APPARATUS; APPARATUS AND INSTRUMENTS FOR RADIATION DETECTION ANALYSIS AND IMAGING; APPARATUS AND INSTRUMENTS FOR RADIATION DETECTION ANALYSIS AND IMAGING BASED ON THE CADMIUM TELLURIDE FAMILY OF MATERIALS FOR NON-MEDICAL USES; APPARATUS AND INSTRUMENTS CONTAINING METROLOGY AND SPECTROGRAPHIC CAPABILITY, NAMELY, SPECTROMETERS, NUCLEAR, X-RAY AND GAMMA RAY IMAGING APPARATUS AND DETECTORS; REPLACEMENT PARTS AND FITTINGS FOR SPECTROMETERS, NUCLEAR, X-RAY AND GAMMA RAY IMAGING APPARATUS AND DETECTORS FOR NON-MEDICAL USES AND NON-MEDICAL X-RAY APPARATUS USED FOR INSPECTION OF BAGGAGE, BEVERAGES, FOODSTUFFS, TOILETRIES, COSMETICS, ELECTRONIC ASSEMBLIES AND CONTAINERS AND FOR THE DETECTION OF EXPLOSIVES, NARCOTICS AND COUNTERFEIT GOODS; APPARATUS AND INSTRUMENTS CONTAINING METROLOGY AND SPECTROGRAPHIC CAPABILITY BASED ON THE CADMIUM TELLURIDE FAMILY OF MATERIALS, NAMELY, SPECTROMETERS, NUCLEAR, X-RAY AND GAMMA RAY IMAGING APPARATUS AND DETECTORS FOR NON-MEDICAL USES; REPLACEMENT PARTS AND FITTINGS FOR SPECTROMETERS, NUCLEAR, X-RAY AND GAMMA RAY IMAGING APPARATUS AND DETECTORS FOR NON-MEDICAL USES, AND NON-MEDICAL X-RAY APPARATUS USED FOR INSPECTION OF BAGGAGE, BEVERAGES, FOODSTUFFS, TOILETRIES, COSMETICS, ELECTRONIC ASSEMBLIES AND CONTAINERS AND FOR THE DETECTION OF EXPLOSIVES, NARCOTICS AND COUNTERFEIT GOODS (U.S. CLS. 21, 23, 26, 36 AND 38).

CLASS 10—MEDICAL APPARATUS

FOR SURGICAL, MEDICAL, DENTAL AND VETERINARY APPARATUS AND INSTRUMENTS, NAMELY, SPECTROMETERS, X-RAY, GAMMA RAY AND NUCLEAR IMAGING APPARATUS AND DETECTORS FOR MEDICAL USES; MEDICAL, DENTAL AND VETERINARY SCANNERS, NAMELY, MEDICAL IMAGING APPARATUS; X-RAY APPARATUS FOR MEDICAL USE; X-RAY SPECTROSCOPIC APPARATUS AND INSTRUMENTS FOR MEDICAL USE; X-RAY SCANNERS FOR MEDICAL USE; IMAGE PROCESSING APPARATUS FOR USE IN MEDICAL X-RAY DIAGNOSTICS; SPECTRAL IMAGING DETECTORS FOR MEDICAL USE; APPARATUS AND INSTRUMENTS FOR RADIATION DETECTION ANALYSIS AND IMAGING BASED ON THE CADMIUM TELLURIDE FAMILY OF MATERIALS FOR MEDICAL USE; RADIOGRAPHIC AND SPECTROGRAPHIC APPARATUS FOR MEDICAL USE; AND REPLACEMENT PARTS AND FITTINGS FOR MEDICAL IMAGING APPARATUS (U.S. CLS. 26, 39 AND 44).

CLASS 42—SCIENTIFIC AND COMPUTER SERVICES

FOR SCIENTIFIC RESEARCH; INDUSTRIAL ANALYSIS, NAMELY, ANALYSIS OF INDUSTRIAL FLUIDS, FOODSTUFFS, ALCOHOLIC AND NON-ALCOHOLIC BEVERAGES, TOILETRIES, COSMETICS, PERFUMES, AFTERSHAVES, PHARMACEUTICALS, CHEMICALS, NARCOTICS, DRUGS, REAGENTS, OILS AND ADDITIVES AND ELECTRONIC, HYDRAULIC AND MECHANICAL COMPONENTS, ASSEMBLIES AND EQUIPMENT; DESIGN AND DEVELOPMENT OF COMPUTER HARDWARE AND SOFTWARE INCLUDING SPECIFIC ALGORITHM DESIGN, TEST AND IMPLEMENTATION; DEVELOPMENT OF ALGORITHMS FOR USE IN IMAGING APPARATUS AND X-RAY SCANNERS; RESEARCH, DESIGN AND DEVELOPMENT OF APPARATUS AND INSTRUMENTS FOR USE IN X-RAY SCANNING AND IMAGING; DESIGN AND DEVELOPMENT OF SPECTROSCOPIC, SPECTROGRAPHIC, RADIOGRAPHIC, X-RAY AND IMAGING APPARATUS (U.S. CLS. 100 AND 101).

CLASS 44—MEDICAL, BEAUTY AND AGRICULTURAL SERVICES

FOR MEDICAL, VETERINARY AND DENTAL SERVICES; MEDICAL PROCESSES INVOLVING IMAGING DIAGNOSIS OR ANALYSIS OF SAMPLES, NAMELY, MEDICAL DIAGNOSTIC TESTING, MONITORING AND REPORTING SERVICES; DENTISTRY AND MEDICAL IMAGING FOR COSMETIC, REPAIR AND RECONSTRUCTION PURPOSES; X-RAY SERVICES, NAMELY, MEDICAL IMAGING SERVICES (U.S. CLS. 100 AND 101).

KRISTINA MORRIS, EXAMINING ATTORNEY

SN 85-288,208. SC EL PROPERTIES LLC, ANAHEIM, CA. FILED 4-6-2011.

SC EL PROPERTIES LLC

THE MARK CONSISTS OF STANDARD CHARACTERS WITHOUT CLAIM TO ANY PARTICULAR FONT, STYLE, SIZE, OR COLOR.

NO CLAIM IS MADE TO THE EXCLUSIVE RIGHT TO USE "PROPERTIES LLC", APART FROM THE MARK AS SHOWN.

CLASS 36—INSURANCE AND FINANCIAL

FOR REAL ESTATE ACQUISITION SERVICES; REAL ESTATE BROKERAGE (U.S. CLS. 100, 101 AND 102).

CLASS 37—CONSTRUCTION AND REPAIR

FOR REAL ESTATE DEVELOPMENT AND BUILDING CONSTRUCTION (U.S. CLS. 100, 103 AND 106).

STEVEN R. FINE, EXAMINING ATTORNEY

SN 85-288,213. SC EL PROPERTIES LLC, ANAHEIM, CA. FILED 4-6-2011.



NO CLAIM IS MADE TO THE EXCLUSIVE RIGHT TO USE "PROPERTIES LLC", APART FROM THE MARK AS SHOWN.

THE MARK CONSISTS OF THE LETTERS "S" "C" "E" "L", EACH WITHIN A BOX ABOVE THE WORDS "PROPERTIES LLC".

CLASS 36—INSURANCE AND FINANCIAL

FOR REAL ESTATE ACQUISITION SERVICES; REAL ESTATE BROKERAGE (U.S. CLS. 100, 101 AND 102).

CLASS 37—CONSTRUCTION AND REPAIR

FOR REAL ESTATE DEVELOPMENT AND BUILDING CONSTRUCTION (U.S. CLS. 100, 103 AND 106).

STEVEN R. FINE, EXAMINING ATTORNEY

SN 85-288,676. LANXESS DEUTSCHLAND GMBH, LEVERKUSEN, FED REP GERMANY, FILED 4-7-2011.

XAMOX

THE MARK CONSISTS OF STANDARD CHARACTERS WITHOUT CLAIM TO ANY PARTICULAR FONT, STYLE, SIZE, OR COLOR.

THE WORDING "XAMOX" HAS NO MEANING IN A FOREIGN LANGUAGE.

CLASS 2—PAINTS

FOR WOOD PRESERVATIVES, WOOD COATINGS AS PAINTS, STAINS AND VARNISHES, WOOD MORDANTS FOR USE IN THE WOOD INDUSTRY AND WOOD STAINS; PROTECTIVE PAINTS (U.S. CLS. 6, 11 AND 16).

CLASS 5—PHARMACEUTICALS

FOR PREPARATIONS FOR DESTROYING VERMIN ALL FOR AGRICULTURE, PUBLIC WORKS, COMMERCIAL AND DOMESTIC USE (U.S. CLS. 6, 18, 44, 46, 51 AND 52).

WILLIAM ROSSMAN, EXAMINING ATTORNEY

SN 85-289,300. JONES, SUZANNE MEREDITH, CENTENNIAL, CO. FILED 4-7-2011.

IZANAH

THE MARK CONSISTS OF STANDARD CHARACTERS WITHOUT CLAIM TO ANY PARTICULAR FONT, STYLE, SIZE, OR COLOR.

THE NAME(S), PORTRAIT(S), AND/OR SIGNATURE(S) SHOWN IN THE MARK IDENTIFIES SUZANNE MEREDITH JONES, WHOSE CONSENT(S) TO REGISTER IS MADE OF RECORD.

CLASS 9—ELECTRICAL AND SCIENTIFIC APPARATUS

FOR SERIES OF PRE-RECORDED COMPACT DISCS, VIDEO RECORDINGS AND ANALOG AND DIGITAL AUDIO TAPE CASSETTES FEATURING WORLD REGGAE; DOWNLOADABLE MUSICAL SOUND RECORDINGS; AND DOWNLOADABLE ELECTRONIC PUBLICATIONS IN THE NATURE OF BOOKS AND BLOGS IN THE FIELD OF NUTRITION, HEALTH, SPIRITUALITY AND RAW FOOD DIETS (U.S. CLS. 21, 23, 26, 36 AND 38).

FIRST USE 6-16-2010; IN COMMERCE 6-16-2010.

CLASS 16—PAPER GOODS AND PRINTED MATTER

FOR BOOKS IN THE FIELD OF NUTRITION, HEALTH, SPIRITUALITY AND RAW FOOD DIETS (U.S. CLS. 2, 5, 22, 23, 29, 37, 38 AND 50).

FIRST USE 6-16-2010; IN COMMERCE 6-16-2010.

CLASS 25—CLOTHING

FOR CLOTHING, NAMELY, LONG SLEEVE T-SHIRTS, SHORT SLEEVE T-SHIRTS, TANK TOPS, HOODED SWEATSHIRTS AND HATS (U.S. CLS. 22 AND 39).

CLASS 35—ADVERTISING AND BUSINESS

FOR PROVIDING MUSIC VIA A GLOBAL COMPUTER NETWORK, NAMELY, ON-LINE RETAIL STORE SERVICES FEATURING DOWNLOADABLE PRE-RECORDED MUSIC (U.S. CLS. 100, 101 AND 102).

FIRST USE 6-16-2010; IN COMMERCE 6-16-2010.

BRENDAN REGAN, EXAMINING ATTORNEY

SN 85-289,336. JONES, SUZANNE MEREDITH, CENTENNIAL, CO. FILED 4-7-2011.

IZANAH JONES

THE MARK CONSISTS OF STANDARD CHARACTERS WITHOUT CLAIM TO ANY PARTICULAR FONT, STYLE, SIZE, OR COLOR.

THE NAME(S), PORTRAIT(S), AND/OR SIGNATURE(S) SHOWN IN THE MARK IDENTIFIES SUZANNE MEREDITH JONES, WHOSE CONSENT(S) TO REGISTER IS MADE OF RECORD.

CLASS 9—ELECTRICAL AND SCIENTIFIC APPARATUS

FOR SERIES OF PRE-RECORDED COMPACT DISCS, VIDEO RECORDINGS AND ANALOG AND DIGITAL AUDIO TAPE CASSETTES FEATURING WORLD REGGAE; DOWNLOADABLE MUSICAL SOUND RECORDINGS; AND DOWNLOADABLE ELECTRONIC PUBLICATIONS IN THE NATURE OF BOOKS AND BLOGS IN THE FIELD OF NUTRITION, HEALTH, SPIRITUALITY AND RAW FOOD DIETS (U.S. CLS. 21, 23, 26, 36 AND 38).

FIRST USE 6-16-2010; IN COMMERCE 6-16-2010.

CLASS 16—PAPER GOODS AND PRINTED MATTER

FOR BOOKS IN THE FIELD OF NUTRITION, HEALTH, SPIRITUALITY AND RAW FOOD DIETS (U.S. CLS. 2, 5, 22, 23, 29, 37, 38 AND 50).

FIRST USE 6-16-2010; IN COMMERCE 6-16-2010.

CLASS 25—CLOTHING

FOR CLOTHING, NAMELY, LONG SLEEVE T-SHIRTS, SHORT SLEEVE T-SHIRTS, TANK TOPS, HOODED SWEATSHIRTS AND HATS (U.S. CLS. 22 AND 39).

CLASS 35—ADVERTISING AND BUSINESS

FOR PROVIDING MUSIC VIA A GLOBAL COMPUTER NETWORK, NAMELY, ON-LINE RETAIL STORE SERVICES FEATURING DOWNLOADABLE PRE-RECORDED MUSIC (U.S. CLS. 100, 101 AND 102).

FIRST USE 6-16-2010; IN COMMERCE 6-16-2010.

BRENDAN REGAN, EXAMINING ATTORNEY

SN 85-289,546. MINDER LLC, PORTLAND, OR. FILED 4-7-2011.

SN 85-290,893. QUOTIDIAN GROUP INC., DBA QUOTIDIAN GROUP INC, HENDERSON, NV. FILED 4-8-2011.

MINDER

THE MARK CONSISTS OF STANDARD CHARACTERS WITHOUT CLAIM TO ANY PARTICULAR FONT, STYLE, SIZE, OR COLOR.

CLASS 9—ELECTRICAL AND SCIENTIFIC APPARATUS

FOR DOWNLOADABLE SOFTWARE IN THE NATURE OF A MOBILE SOFTWARE APPLICATION AND SOFTWARE PLUG-IN APPLICATION FOR RECORDKEEPING, BILL PAYING, ORGANIZING AND ARCHIVING ONLINE FILES AND FOLDERS, AND PRODUCTIVITY MANAGEMENT IN THE NATURE OF A DATABASE FOR THE USER TO INPUT INFORMATION, LISTS, CALENDAR DATES, FILES AND DATA WHICH IS ORGANIZED INTO A SINGLE, RETRIEVABLE DATABASE (U.S. CLS. 21, 23, 26, 36 AND 38).

CLASS 16—PAPER GOODS AND PRINTED MATTER

FOR BINDERS; FILE FOLDERS; HANGING FOLDERS; ORGANIZATIONAL KITS CONTAINING PLANNING FILE FOLDERS, BINDERS, CALENDARS, FORM TEMPLATES AND PRINTED GUIDELINES FOR RECORDKEEPING ORGANIZATION; BOOKS IN THE FIELD OF ORGANIZATION AND RECORD KEEPING; INDEX DIVIDERS; A SERIES OF BOOKS, WRITTEN ARTICLES, HANDOUTS AND WORKSHEETS IN THE FIELD OF PERSONAL AND BUSINESS ORGANIZATION, RECORDKEEPING AND PROJECT MANAGEMENT (U.S. CLS. 2, 5, 22, 23, 29, 37, 38 AND 50).

CLASS 42—SCIENTIFIC AND COMPUTER SERVICES

FOR APPLICATION SERVICE PROVIDER, NAMELY, HOSTING, MANAGING, DEVELOPING, AND MAINTAINING APPLICATIONS, SOFTWARE, AND WEB SITES, IN THE FIELDS OF PERSONAL PRODUCTIVITY, DATA MANAGEMENT FOR WIRELESS DELIVERY OF CONTENT TO HANDHELD COMPUTERS, LAPTOPS AND MOBILE ELECTRONIC DEVICES; PROVIDING A WEB SITE FEATURING TECHNOLOGY IN THE NATURE OF NON-DOWNLOADABLE SOFTWARE THAT ENABLES PEOPLE TO ADMINISTER AND MANAGE INFORMATION MANAGEMENT PROJECTS, PROGRAMS, AND RECORDKEEPING; PROVIDING A WEBSITE THAT ENABLES USERS TO SUBSCRIBE TO COACHING, MENTORING, AND/OR EDUCATIONAL SERVICES; PROVIDING TEMPORARY USE OF ONLINE NON-DOWNLOADABLE SOFTWARE AND NON-DOWNLOADABLE SOFTWARE APPLICATIONS FOR DATABASE MANAGEMENT, RECORDKEEPING, AND PERSONAL AND BUSINESS ORGANIZATION AND MAINTENANCE; SOFTWARE AS A SERVICE (SAAS) SERVICES FEATURING SOFTWARE FOR RECORDKEEPING, DATABASE MANAGEMENT, ORGANIZATION, AND BILL PAYING (U.S. CLS. 100 AND 101).
ANDREA K. NADELMAN, EXAMINING ATTORNEY

TRIS

THE MARK CONSISTS OF STANDARD CHARACTERS WITHOUT CLAIM TO ANY PARTICULAR FONT, STYLE, SIZE, OR COLOR.

CLASS 9—ELECTRICAL AND SCIENTIFIC APPARATUS

FOR COMPUTER BAGS; COMPUTER CARRYING CASES; COMPUTER GAME CARTRIDGES; COMPUTER GAME DISCS; COMPUTER GAME PROGRAMS; COMPUTER GAME SOFTWARE; COMPUTER GAME SOFTWARE DOWNLOADABLE FROM A GLOBAL COMPUTER NETWORK; COMPUTER GAME SOFTWARE FOR GAMING MACHINES INCLUDING SLOT MACHINES OR VIDEO LOTTERY TERMINALS; COMPUTER GAME SOFTWARE FOR PERSONAL COMPUTERS AND HOME VIDEO GAME CONSOLES; COMPUTER GAME SOFTWARE FOR USE ON MOBILE AND CELLULAR PHONES; COMPUTER GAME SOFTWARE FOR USE WITH PERSONAL COMPUTERS, HOME VIDEO GAME CONSOLES USED WITH TELEVISIONS AND ARCADE-BASED VIDEO GAME CONSOLES; COMPUTER GRAPHICS SOFTWARE; COMPUTER SCREEN SAVER SOFTWARE; COMPUTER SOFTWARE AND FIRMWARE FOR GAMES OF CHANCE ON ANY COMPUTERIZED PLATFORM, INCLUDING DEDICATED GAMING CONSOLES, VIDEO BASED SLOT MACHINES, REEL BASED SLOT MACHINES, AND VIDEO LOTTERY TERMINALS; COMPUTER SOFTWARE FOR COMMUNICATING WITH USERS OF HAND-HELD COMPUTERS; COMPUTER-GAMING SOFTWARE; COMPUTERS; DOWNLOADABLE COMPUTER GAME PROGRAMS; DOWNLOADABLE COMPUTER GAME SOFTWARE VIA A GLOBAL COMPUTER NETWORK AND WIRELESS DEVICES; DOWNLOADABLE COMPUTER GRAPHICS; DOWNLOADABLE COMPUTER PROGRAMS FEATURING POSITIONABLE GAME PIECE FIGURES FOR USE IN THE FIELD OF COMPUTER GAMES; DOWNLOADABLE RING TONES, GRAPHICS AND MUSIC VIA A GLOBAL COMPUTER NETWORK AND WIRELESS DEVICES; DVDS FEATURING DRAMA ROMANCE AND FANTASY; ENTERTAINMENT SYSTEM COMPRISING A COMPUTER, MULTIPLE IMAGE DISPLAY SCREEN, MULTIPLE INPUT DEVICES AND A PRINTER; MOTION PICTURE FILMS ABOUT DRAMA ENTERTAINMENT AND FANTASY (U.S. CLS. 21, 23, 26, 36 AND 38).

CLASS 14—JEWELRY

FOR JEWELRY (U.S. CLS. 2, 27, 28 AND 50).

CLASS 16—PAPER GOODS AND PRINTED MATTER

FOR ADHESIVE-BACKED PHOTOGRAPHS; ART PRINTS COMPRISED OF DIGITAL ILLUSTRATIONS ORIGINATING FROM PHOTOGRAPHS; CALENDARS; GREETING CARDS; GREETINGS CARDS AND POSTCARDS; MOUNTED POSTERS; PAPER LETTERS AND NUMBER FOR USE IN MAKING WALL ART DECALS; PHOTOGRAPH MOUNTS; PHOTOGRAPH STANDS; PHOTOGRAPHIC ALBUMS; PHOTOGRAPHIC OR ART MOUNTS; PHOTOGRAPHIC PRINTS; PHOTOGRAPHS; PHOTOGRAPHS THAT HAVE BEEN COMPUTER MANIPULATED AND ENHANCED TO LOOK LIKE PAINTINGS; POSTER BOARD; POSTERS; POSTERS MADE OF PAPER; UNMOUNTED AND MOUNTED PHOTOGRAPHS; UNMOUNTED POSTERS; VINYL LETTERS AND NUMBERS FOR USE IN MAKING WALL ART DECALS (U.S. CLS. 2, 5, 22, 23, 29, 37, 38 AND 50).

CLASS 25—CLOTHING

FOR BASEBALL CAPS AND HATS; BELTS; BELTS FOR CLOTHING; CAPS; DRESS PANTS; DRESS SHIRTS; DRESSES; DRESSING GOWNS AND BATH ROBES; FOOTWEAR; HATS; HOODED PULLOVERS; HOODED SWEATSHIRTS; HOODS; JACKETS; LEATHER BELTS; T-SHIRTS; WAIST BELTS (U.S. CLS. 22 AND 39).

KAREN BRACEY, EXAMINING ATTORNEY

SN 85-291,428. CENTERSCOPE TECHNOLOGIES, INC., ELKRIDGE, MD. FILED 4-11-2011.



NO CLAIM IS MADE TO THE EXCLUSIVE RIGHT TO USE "INTERNATIONAL", APART FROM THE MARK AS SHOWN.

THE MARK CONSISTS OF THE WORDING "CSTI INTERNATIONAL" AS FOLLOWS: THE WORDING "CSTI" IN STYLIZED LOWERCASE LETTERS AND UNDER "CSTI", THE MARK CONSISTS OF THE WORDING "INTERNATIONAL". ABOVE "CSTI", IS A THREE QUARTER SIZE GLOBE WITH HORIZONTAL AND VERTICAL STRIPES.

CLASS 35—ADVERTISING AND BUSINESS

FOR BUSINESS SERVICES, NAMELY, FACILITIES MANAGEMENT OF TECHNICAL OPERATIONS (U.S. CLS. 100, 101 AND 102).

FIRST USE 3-5-2011; IN COMMERCE 3-5-2011.

CLASS 42—SCIENTIFIC AND COMPUTER SERVICES

FOR PRODUCT DEVELOPMENT AND ENGINEERING SERVICES FOR OTHERS; PROVIDING MANAGEMENT OF DEPLOYMENT CENTERS (U.S. CLS. 100 AND 101).

FIRST USE 3-5-2011; IN COMMERCE 3-5-2011.
LOURDES AYALA, EXAMINING ATTORNEY

SN 85-293,932. BABYBIRD LLC, COLUMBUS, OH. FILED 4-13-2011.

BABYBIRD

THE MARK CONSISTS OF STANDARD CHARACTERS WITHOUT CLAIM TO ANY PARTICULAR FONT, STYLE, SIZE, OR COLOR.

CLASS 25—CLOTHING

FOR CLOTHING FOR INFANTS, TODDLERS, AND CHILDREN, NAMELY, SHIRTS, LONG-SLEEVED SHIRTS, SHORT-SLEEVED SHIRTS, T-SHIRTS, SWEATSHIRTS, NIGHT SHIRTS, PANTS, SHORTS, SWEAT PANTS, SOCKS, BOOTIES, HATS, CAPS, ONE PIECE GARMENTS, CLOTH DIAPERS, PAJAMAS, SLEEPERS, CLOTH BIBS, BEACH WEAR, SWIMSUITS, COATS, JACKETS, DRESSES, JUMPERS, PULLOVERS, HOODED SWEATSHIRTS, SCARVES, SWEATERS, SKIRTS, UNDERPANTS, AND UNDERSHIRTS (U.S. CLS. 22 AND 39).

CLASS 35—ADVERTISING AND BUSINESS

FOR RETAIL STORE SERVICES AND ON-LINE RETAIL STORE SERVICES FEATURING CLOTHING, HEADGEAR, FOOTWEAR, AND CLOTHING ACCESSORIES FOR INFANTS, TODDLERS, AND CHILDREN (U.S. CLS. 100, 101 AND 102).

NATALIE POLZER, EXAMINING ATTORNEY

SN 85-294,556. REZOLVE GROUP, INC., BOSTON, MA. FILED 4-13-2011.

TuitionHelp

THE MARK CONSISTS OF STANDARD CHARACTERS WITHOUT CLAIM TO ANY PARTICULAR FONT, STYLE, SIZE, OR COLOR.

CLASS 35—ADVERTISING AND BUSINESS

FOR BUSINESS SERVICES, NAMELY, PROVIDING ASSISTANCE IN THE FORM OF CONSULTATION, MANAGEMENT AND OFFICE ADMINISTRATION SERVICES FOR TUITION REIMBURSEMENT PROGRAMS OF OTHERS (U.S. CLS. 100, 101 AND 102).

CLASS 36—INSURANCE AND FINANCIAL

FOR COLLEGE CONSULTING SERVICES, NAMELY, ASSISTING OTHERS IN APPLYING FOR TUITION REIMBURSEMENT AND COMPLETING THE APPLICATION PROCESS (U.S. CLS. 100, 101 AND 102).

KAREN BRACEY, EXAMINING ATTORNEY

SN 85-295,060. HERBALIFE INTERNATIONAL, INC., LOS ANGELES, CA. FILED 4-14-2011.

NUTRICION PARA EL DEPORTISTA 24 HORAS

THE MARK CONSISTS OF STANDARD CHARACTERS WITHOUT CLAIM TO ANY PARTICULAR FONT, STYLE, SIZE, OR COLOR.

THE ENGLISH TRANSLATION OF THE MARK IS "NUTRITION FOR THE 24 HOUR ATHLETE".

CLASS 5—PHARMACEUTICALS

FOR DIETARY AND NUTRITIONAL SUPPLEMENTS FOR SPORTS AND FITNESS (U.S. CLS. 6, 18, 44, 46, 51 AND 52).

FIRST USE 5-23-2011; IN COMMERCE 5-23-2011.

CLASS 32—LIGHT BEVERAGES

FOR PREPARATIONS FOR MAKING SPORTS AND FITNESS BEVERAGES (U.S. CLS. 45, 46 AND 48).

FIRST USE 5-23-2011; IN COMMERCE 5-23-2011.

KAREN K. BUSH, EXAMINING ATTORNEY

SN 85-296,319. MYL DIGITAL LIMITED, LONDON, UNITED KINGDOM, FILED 4-15-2011.

PUPPY CLUB

THE MARK CONSISTS OF STANDARD CHARACTERS WITHOUT CLAIM TO ANY PARTICULAR FONT, STYLE, SIZE, OR COLOR.

PRIORITY CLAIMED UNDER SEC. 44(D) ON UNITED KINGDOM APPLICATION NO. 2576054, FILED 3-23-2011.

OWNER OF UNITED KINGDOM REG. NO. 2576054, DATED 3-23-2011, EXPIRES 3-23-2021.

OWNER OF U.S. REG. NO. 4,093,045.

NO CLAIM IS MADE TO THE EXCLUSIVE RIGHT TO USE "PUPPY", APART FROM THE MARK AS SHOWN.

CLASS 9—ELECTRICAL AND SCIENTIFIC APPARATUS

FOR COMPUTER GAMES SOFTWARE; COMPUTER GAMES SOFTWARE FOR A VIRTUAL PET COMPUTER GAME AND OTHER ASSOCIATED VIRTUAL ACTIVITIES WITHIN THE FRAMEWORK OF THE GAME, NAMELY, SOCIAL NETWORKING; ENTERTAINMENT SOFTWARE, NAMELY, SOFTWARE FOR PLAYING COMPUTER GAMES; INTERACTIVE ENTERTAINMENT SOFTWARE FOR PLAYING COMPUTER GAMES; INTERACTIVE COMPUTER GAMES SOFTWARE; VIRTUAL REALITY GAMES SOFTWARE; DOWNLOADABLE COMPUTER SOFTWARE FOR PLAYING COMPUTER GAMES; DOWNLOADABLE ELECTRONIC PUBLICATIONS, NAMELY, NEWSLETTERS AND MAGAZINES IN THE FIELD OF COMPUTER GAMES (U.S. CLS. 21, 23, 26, 36 AND 38).

CLASS 41—EDUCATION AND ENTERTAINMENT

FOR ENTERTAINMENT SERVICES, NAMELY, PROVIDING NON-DOWNLOADABLE COMPUTER GAMES VIA THE INTERNET; ENTERTAINMENT SERVICES IN THE FORM OF THE PROVISION OF NON-DOWNLOADABLE COMPUTER GAMES VIA THE INTERNET; ENTERTAINMENT SERVICES IN THE FORM OF PROVIDING NON-DOWNLOADABLE ALTERNATE REALITY GAMES VIA THE INTERNET; ENTERTAINMENT SERVICES IN THE FORM OF PROVIDING TEMPORARY USE OF A NON-DOWNLOADABLE VIRTUAL PET COMPUTER GAME VIA THE INTERNET; ENTERTAINMENT SERVICES IN THE NATURE OF ORGANIZING COMPETITIONS AND GAMES IN THE FIELD OF COMPUTER GAMES (U.S. CLS. 100, 101 AND 107).

ANDREW RHIM, EXAMINING ATTORNEY

SN 85-297,632. ALADDIN TEMP-RITE LLC, HENDERSONVILLE, TN. FILED 4-18-2011.

ALADDIN TEMP-RITE

THE MARK CONSISTS OF STANDARD CHARACTERS WITHOUT CLAIM TO ANY PARTICULAR FONT, STYLE, SIZE, OR COLOR.

OWNER OF U.S. REG. NOS. 879,724, 3,521,387 AND OTHERS.

CLASS 11—ENVIRONMENTAL CONTROL APPARATUS

FOR ELECTROMAGNETIC INDUCTION HEATERS FOR HEATING AND WARMING FOOD; FOOD TRAY HEATING SYSTEMS, NAMELY, INDUCTION HEATERS, HEAT RETENTIVE FOOD TRAYS, AND INSULATED DOME COVERS; HEATED AND REFRIGERATED CABINET UNITS COMPRISED OF ELECTRICAL CIRCUIT BREAKERS, CONTROLLERS AND DISPLAY MONITORS FOR FOOD STORAGE, RETHERMALIZATION AND DISTRIBUTION; INDUCTION HEATERS AND ASSOCIATED METAL DISKS FOR USE IN HEATING THERMAL INSULATED DELIVERY BAGS DESIGNED TO KEEP FOOD WARM DURING TRANSPORT; CONVECTION OVENS; INDUCTION HEATERS FOR USE IN HEATING INSULATED PELLET BASES (U.S. CLS. 13, 21, 23, 31 AND 34).

FIRST USE 11-30-1995; IN COMMERCE 11-30-1995.

CLASS 12—VEHICLES

FOR RETHERMALIZATION AND MEAL DELIVERY CARTS FOR THE DELIVERY OF MEALS IN INSTITUTIONS (U.S. CLS. 19, 21, 23, 31, 35 AND 44).

FIRST USE 8-31-1979; IN COMMERCE 8-31-1979.

CLASS 16—PAPER GOODS AND PRINTED MATTER

FOR PAPER TRAY MATS (U.S. CLS. 2, 5, 22, 23, 29, 37, 38 AND 50).

FIRST USE 8-15-2002; IN COMMERCE 8-15-2002.

CURTIS FRENCH, EXAMINING ATTORNEY

SN 85-297,987. MARVELO MEDIA S.R.L., BUKAREST, ROMANIA, FILED 4-18-2011.



OWNER OF ERPN CMNTY TM OFC REG. NO. 008961708, DATED 9-2-2010, EXPIRES 3-17-2020.

THE MARK CONSISTS OF IMAGE OF A WOMAN SITTING INSIDE HEART WITH THE TERM "FLIRTFAIR".

CLASS 35—ADVERTISING AND BUSINESS

FOR ADVERTISING AND MARKETING; ADVERTISING ON THE INTERNET, FOR OTHERS; RENTAL OF ADVERTISING SPACE INCLUDING RENTAL OF ADVERTISING SPACE WITHIN AN ADVERTISING BANNER, INCLUDING ON THE INTERNET; BUSINESS MANAGEMENT SERVICES; BUSINESS ADMINISTRATION; OFFICE FUNCTIONS; ARRANGING OF COMMERCIAL AND BUSINESS CONTACTS, NAMELY, BUSINESS NETWORKING SERVICES; MARKET RESEARCH AND PUBLIC OPINION POLLING; PROVIDING AN INTERNET WEBSITE PORTAL FEATURING PROMOTION AND ADVERTISING FOR HOME SERVICE PROVIDERS AND PRODUCT MANUFACTURERS (U.S. CLS. 100, 101 AND 102).

CLASS 38—COMMUNICATION

FOR PROVIDING CHAT LINES UTILIZING THE INTERNET; PROVIDING INTERNET CHAT ROOMS; PROVIDING ON-LINE FORUMS FOR TRANSMISSION OF MESSAGES AMONG COMPUTER USERS; PROVIDING ACCESS TO A GLOBAL COMPUTER NETWORK FOR THE DOWNLOADING OF COMPUTER SOFTWARE, COMPUTER PROGRAMS AND INFORMATION; ELECTRONIC MAIL SERVICES; MAILBOX SERVICES, IN THE NATURE OF VOICE MAIL SERVICES; ELECTRONIC TRANSMISSION OF INFORMATION AND MESSAGES OF ALL KINDS IN THE FORM OF IMAGES AND SOUND ON THE INTERNET; MOBILE TELEPHONE SERVICES, INCLUDING TEXT MESSAGING AND VOICE MAIL SERVICES (U.S. CLS. 100, 101 AND 104).

CLASS 42—SCIENTIFIC AND COMPUTER SERVICES

FOR COMPUTER SERVICES, NAMELY, PROVIDING SEARCH PLATFORMS TO ALLOW USERS TO SHARE PERSONAL AND SOCIAL INTERESTS (U.S. CLS. 100 AND 101).

CLASS 45—PERSONAL AND LEGAL SERVICES

FOR DATING SERVICES, INCLUDING VIA THE INTERNET; PARTNERSHIP CONSULTANCY, NAMELY, CONSULTANCY RELATING TO MARRIAGE PARTNER INTRODUCTION; DATING SERVICES FEATURING CONDUCTING OF PARTNERSHIP ANALYSES AND PERSONALITY TESTS AND ANALYSIS OF PERSONAL PROFILES TO DETERMINE DATING OR MARRIAGE COMPATIBILITY, INCLUDING VIA THE INTERNET AND THROUGH PERSONAL CONSULTATION (U.S. CLS. 100 AND 101).

MELISSA VALLILLO, EXAMINING ATTORNEY

CLASS 1—CHEMICALS

FOR CHEMICAL ADDITIVES FOR ENGINE OIL, RADIATOR FLUIDS, VEHICLE FUELS AND TRANSMISSION FLUID; AUTOMOBILE TIRE INFLATOR SEALERS, DISK BRAKE ADHESIVE; FLUIDS FOR BRAKES AND POWER STEERING; DE-ICING FLUIDS FOR AUTOMOBILES, TRUCKS, AND VEHICLE ENGINES (U.S. CLS. 1, 5, 6, 10, 26 AND 46).

CLASS 2—PAINTS

FOR CORROSION INHIBITING PAINT TYPE SPRAY COATING FOR AUTOMOTIVE AND TRUCK BATTERIES; UNDERCOATING FOR VEHICLE CHASSIS (U.S. CLS. 6, 11 AND 16).

CLASS 3—COSMETICS AND CLEANING PREPARATIONS

FOR AUTOMOBILE CLEANING PREPARATIONS, NAMELY, CLEANERS FOR ENGINES, MOTORS, CARBURETORS, INJECTORS, BRAKES, GLASS, TIRES, CLUTCHES, CV JOINTS AND VEHICLE BODIES; AUTOMOBILE CLEANING PREPARATIONS, NAMELY, CLEANERS FOR USE IN CARBURETORS, AUTOMATIC CHOKES AND VARIOUS ENGINE PARTS AND COMPONENTS; AUTOMOBILE CLEANING PREPARATIONS FOR FUEL INJECTION SYSTEMS; INDUSTRIAL STRENGTH HAND CLEANERS (U.S. CLS. 1, 4, 6, 50, 51 AND 52).

CLASS 4—LUBRICANTS AND FUELS

FOR NON CHEMICAL ADDITIVES FOR ENGINE OIL, RADIATOR FLUIDS, VEHICLE FUELS AND TRANSMISSION FLUID; LUBRICATING GREASE FOR VEHICLES, NAMELY, GREASE FOR BRAKES AND POWER STEERING; AUTOMOTIVE LUBRICANTS, NAMELY, PENETRATING OIL, SILICONE SPRAY; AUTOMOTIVE LUBRICANTS, NAMELY, TUNE OIL FOR USE IN CARBURETORS, AUTOMATIC CHOKES, PCV SYSTEMS AND VARIOUS ENGINE PARTS AND COMPONENTS; PENETRATING OIL; ALL PURPOSE SILICONE SPRAY LUBRICANT (U.S. CLS. 1, 6 AND 15).

MARK SPARACINO, EXAMINING ATTORNEY

SN 85-299,015, UNITED WAY OF THE BAY AREA, SAN FRANCISCO, CA. FILED 4-19-2011.

MAKE IT BE

THE MARK CONSISTS OF STANDARD CHARACTERS WITHOUT CLAIM TO ANY PARTICULAR FONT, STYLE, SIZE, OR COLOR.

CLASS 35—ADVERTISING AND BUSINESS

FOR CHARITABLE SERVICES, NAMELY, PROMOTING PUBLIC AWARENESS OF POVERTY IN THE BAY AREA (U.S. CLS. 100, 101 AND 102).

FIRST USE 4-13-2011; IN COMMERCE 4-13-2011.

CLASS 36—INSURANCE AND FINANCIAL

FOR CHARITABLE FUNDRAISING SERVICES TO REDUCE POVERTY IN THE BAY AREA (U.S. CLS. 100, 101 AND 102).

FIRST USE 4-13-2011; IN COMMERCE 4-13-2011.
ALEX KEAM, EXAMINING ATTORNEY

SN 85-298,478, PIDILITE USA, INC., DBA CYCLO INDUSTRIES, INC., JUPITER, FL. FILED 4-19-2011.

BREAK-THRU

THE MARK CONSISTS OF STANDARD CHARACTERS WITHOUT CLAIM TO ANY PARTICULAR FONT, STYLE, SIZE, OR COLOR.

SN 85-299,026. KEY, SHAWN ROY, GAINESVILLE, VA. FILED 4-19-2011.

REIGN OF KINGS

THE MARK CONSISTS OF STANDARD CHARACTERS WITHOUT CLAIM TO ANY PARTICULAR FONT, STYLE, SIZE, OR COLOR.

CLASS 9—ELECTRICAL AND SCIENTIFIC APPARATUS

FOR COMPACT DISCS, AUDIO RECORDINGS, AND DOWNLOADABLE AUDIO FILES FEATURING MUSIC (U.S. CLS. 21, 23, 26, 36 AND 38). FIRST USE 12-26-2010; IN COMMERCE 12-26-2010.

CLASS 41—EDUCATION AND ENTERTAINMENT

FOR PROVIDING A WEBSITE FOR ENTERTAINMENT PURPOSES WHERE USERS CAN VIEW AND LISTEN TO AUDIO AND VIDEO FILES FEATURING MUSIC AND MUSICAL PERFORMANCES (U.S. CLS. 100, 101 AND 107).

FIRST USE 12-26-2010; IN COMMERCE 12-26-2010. ALEX KEAM, EXAMINING ATTORNEY

CLASS 41—EDUCATION AND ENTERTAINMENT

FOR DEVELOPMENT AND DISSEMINATION OF EDUCATIONAL MATERIALS FOR EDUCATORS IN THE FIELD OF ELEMENTARY, MIDDLE AND HIGH SCHOOL EDUCATION; EDUCATIONAL SERVICES, NAMELY, CURRICULUM DEVELOPMENT FOR EDUCATORS IN THE FIELD OF ELEMENTARY, MIDDLE AND HIGH SCHOOL EDUCATION; DEVELOPMENT AND DISSEMINATION OF TEACHING EFFECTIVENESS AND STUDENT ACHIEVEMENT ASSESSMENT MATERIALS FOR OTHERS IN THE FIELD OF ELEMENTARY, MIDDLE AND HIGH SCHOOL EDUCATION; EDUCATIONAL CONSULTING SERVICES PROVIDED TO OTHERS IN THE FIELDS OF ELEMENTARY, MIDDLE AND HIGH SCHOOL EDUCATION AND IMPROVING STUDENT LEARNING PERFORMANCE; AND DEVELOPMENT AND DISSEMINATION OF EDUCATIONAL MATERIALS IN THE NATURE OF RESEARCH-BASED STUDENT ACHIEVEMENT DIAGNOSTIC TOOLS IN THE FIELD OF ELEMENTARY, MIDDLE AND HIGH SCHOOL EDUCATION; EDUCATIONAL SERVICES, NAMELY, PROVIDING COURSES OF INSTRUCTION AT THE ELEMENTARY, MIDDLE SCHOOL AND HIGH SCHOOL LEVEL (U.S. CLS. 100, 101 AND 107).

AMY KERTGATE, EXAMINING ATTORNEY

SN 85-300,449. THE AUSTRALIAN WINE RESEARCH INSTITUTE LTD, URRBRAE SA, AUSTRALIA, FILED 4-20-2011.

SN 85-300,422. BASIS EDUCATIONAL GROUP, INC., TUCSON, AZ. FILED 4-20-2011.

BASIS EDUCATIONAL GROUP

THE MARK CONSISTS OF STANDARD CHARACTERS WITHOUT CLAIM TO ANY PARTICULAR FONT, STYLE, SIZE, OR COLOR.

NO CLAIM IS MADE TO THE EXCLUSIVE RIGHT TO USE "EDUCATIONAL GROUP", APART FROM THE MARK AS SHOWN.

CLASS 35—ADVERTISING AND BUSINESS

FOR BUSINESS MANAGEMENT AND OPERATION ASSISTANCE TO PUBLIC SCHOOLS, CHARTER SCHOOLS AND PRIVATE SCHOOLS; CONSULTATION SERVICES REGARDING BUSINESS MANAGEMENT AND OPERATION ASSISTANCE TO PUBLIC SCHOOLS, CHARTER SCHOOLS AND PRIVATE SCHOOLS IN THE FIELD OF ELEMENTARY, MIDDLE SCHOOL AND HIGH SCHOOL EDUCATION; EMPLOYMENT RECRUITING AND STAFFING SERVICES IN THE EDUCATIONAL FIELD (U.S. CLS. 100, 101 AND 102).



NO CLAIM IS MADE TO THE EXCLUSIVE RIGHT TO USE "CRISP AND LUSCIOUS", APART FROM THE MARK AS SHOWN.

THE MARK CONSISTS OF A RECTANGLE DIVIDED DIAGONALLY IN HALF, TO FORM TWO TRIANGLES. UNDER THE RECTANGLE ARE EVENLY SPACED VERTICAL LINES, SUGGESTING A RULER, WITH THE TERM "CRISP" UNDER THE LEFT END OF THE DESIGN AND THE TERM "LUSCIOUS" AT THE RIGHT END.

CLASS 35—ADVERTISING AND BUSINESS

FOR ADVERTISING, MARKETING AND PROMOTIONAL SERVICES; BUSINESS ADVICE AND CONSULTATION SERVICES; MARKET RESEARCH SERVICES; PROVISION OF INFORMATION IN RELATION TO THE AFORESAID SERVICES; ALL OF THE AFORESAID SERVICES INCLUDING SERVICES RELATED TO THE WINE AND BEVERAGE INDUSTRIES (U.S. CLS. 100, 101 AND 102).

CLASS 42—SCIENTIFIC AND COMPUTER SERVICES

SN 85-300,680. B. B. CRAFTS INC., ONTARIO, CA. FILED 4-21-2011.

FOR SCIENTIFIC RESEARCH CONSULTING SERVICES; RESEARCH AND DEVELOPMENT SERVICES IN THE FIELD OF NEW WINE AND BEVERAGE PRODUCTS FOR OTHERS; SCIENTIFIC ADVISORY SERVICES IN RELATION TO WINE AND BEVERAGES; COMPILATION OF SCIENTIFIC INFORMATION IN THE AREA OF WINE AND BEVERAGE RESEARCH; SCIENTIFIC DATA ANALYSIS SERVICES; CERTIFICATION SERVICES, NAMELY, TESTING, ANALYSIS, AND EVALUATION OF THE GOODS AND SERVICES OF OTHERS FOR THE PURPOSE OF CERTIFICATION IN THIS CLASS; CERTIFICATION OF QUALITY, AND STANDARD OF WINES, NAMELY, TESTING, ANALYSIS AND EVALUATION OF TYPES OF WINE FOR QUALITY AND STANDARD CERTIFICATION PURPOSES; BENCHMARKING SERVICES, NAMELY, ANALYSIS OF WINE TO DETERMINE ITS POSITION ON A STYLE SCALE; SCIENTIFIC TECHNICAL TESTING AND ANALYSIS SERVICES IN THE FIELD OF WINE AND BEVERAGES; PROVISION OF INFORMATION RELATING TO THE AFORESAID SERVICES; ALL OF THE AFORESAID SERVICES INCLUDING SERVICES RELATED TO THE WINE AND BEVERAGE INDUSTRIES (U.S. CLS. 100 AND 101).

SUE LAWRENCE, EXAMINING ATTORNEY

BBCRAFTS

THE MARK CONSISTS OF STANDARD CHARACTERS WITHOUT CLAIM TO ANY PARTICULAR FONT, STYLE, SIZE, OR COLOR.

CLASS 24—FABRICS

FOR TULLE AND FABRICS, NAMELY, FLAX FABRICS AND FABRICS FOR TEXTILE USE (U.S. CLS. 42 AND 50).

CLASS 28—TOYS AND SPORTING GOODS

FOR FABRIC RIBBONS (U.S. CLS. 22, 23, 38 AND 50).
SAMUEL E. SHARPER JR., EXAMINING ATTORNEY

SN 85-300,661. ALICIA ADAMS ALPACA INC., STANFORDVILLE, NY. FILED 4-21-2011.

ALICIA ADAMS ALPACA

THE MARK CONSISTS OF STANDARD CHARACTERS WITHOUT CLAIM TO ANY PARTICULAR FONT, STYLE, SIZE, OR COLOR.

NO CLAIM IS MADE TO THE EXCLUSIVE RIGHT TO USE "ALPACA", APART FROM THE MARK AS SHOWN.

THE NAME(S), PORTRAIT(S), AND/OR SIGNATURE(S) SHOWN IN THE MARK IDENTIFIES "ALICIA ADAMS", WHOSE CONSENT(S) TO REGISTER IS MADE OF RECORD.

CLASS 24—FABRICS

FOR TEXTILES MADE FROM ALPACA WOOL, NAMELY, THROWS, BED BLANKETS, LAP BLANKETS, AND BABY BLANKETS (U.S. CLS. 42 AND 50).

FIRST USE 11-1-2009; IN COMMERCE 11-1-2009.

CLASS 25—CLOTHING

FOR CLOTHING MADE PRIMARILY OF ALPACA WOOL, NAMELY, WRAPS, CAPES, SCARVES, GLOVES, HATS, SOCKS, SWEATERS, SKIRTS, JACKETS, COATS, TIES, AND INFANT WEAR (U.S. CLS. 22 AND 39).

FIRST USE 11-1-2009; IN COMMERCE 11-1-2009.

KELLY BOULTON, EXAMINING ATTORNEY

SN 85-301,144. WARRIOR RUGBY, LLC, OREM, UT. FILED 4-21-2011.



THE MARK CONSISTS OF A CREST WITH FOUR DIFFERENT PARTS CONTAINING DESIGNS. THE UPPER LEFT DESIGN IS A STYLIZED VERSION OF A TRIQUETRA. THE UPPER RIGHT DESIGN IS A STYLIZED, MAORI-INFLUENCED MASK. THE LOWER LEFT DESIGN IS A SERIES OF STARS RESEMBLING THOSE ON THE US FLAG. THE LOWER RIGHT DESIGN IS A SERIES OF STRIPES RESEMBLING THOSE ON THE US FLAG.

CLASS 9—ELECTRICAL AND SCIENTIFIC APPARATUS

FOR AUDIO RECORDINGS AND VIDEO RECORDINGS IN THE FIELD OF RUGBY; PRERECORDED CDS, DVDS, OPTICAL DISKS, VIDEO TAPES, AND DOWNLOADABLE AUDIO AND VIDEO FILES FEATURING THE SPORT OF RUGBY; DOWNLOADABLE COMPUTER SOFTWARE FOR VIEWING DATABASES OF INFORMATION, STATISTICAL INFORMATION, TRIVIA, POLLING INFORMATION, AND INTERACTIVE POLLING IN THE FIELD OF RUGBY PROVIDED OVER THE INTERNET; DOWNLOADABLE COMPUTER SOFTWARE FOR SCREENSAVERS, WALLPAPERS, BROWSERS, SKINS, AVATARS, AND CURSORS OVER THE INTERNET; DOWNLOADABLE ELECTRONIC PUBLICATIONS IN THE NATURE OF MAGAZINES, NEWSLETTERS, COLORING BOOKS, GAME SCHEDULES ALL IN THE FIELD OF RUGBY PROVIDED OVER THE INTERNET; DOWNLOADABLE CATALOGS PROVIDED OVER THE INTERNET FEATURING AN ARRAY OF RUGBY-THEMED PRODUCTS; COMPUTER ACCESSORIES, NAMELY, MOUSE PADS, COMPACT AND OPTICAL DISK CASES, COMPUTER CARRY-ON CASES, KEYBOARD WRIST PADS, RADIOS, TELEPHONES AND CELL PHONE ACCESSORIES, NAMELY, FACE PLATES AND CELL PHONE COVERS (U.S. CLS. 21, 23, 26, 36 AND 38).

CLASS 41—EDUCATION AND ENTERTAINMENT

FOR ENTERTAINMENT SERVICES IN THE NATURE OF RUGBY GAMES AND EXHIBITIONS; PROVIDING SPORTS AND ENTERTAINMENT INFORMATION VIA A GLOBAL COMPUTER NETWORK, WEBSITE, AND BY CABLE, SATELLITE, TELEVISION AND RADIO; ORGANIZING AND CONDUCTING ATHLETIC COMPETITIONS, NAMELY PROFESSIONAL RUGBY GAMES AND EXHIBITIONS; RUGBY FAN CLUB SERVICES; ENTERTAINMENT SERVICES, NAMELY MUSICAL AND DANCE PERFORMANCES PROVIDED DURING INTERVALS AT SPORTS EVENTS; PRODUCTION OF RADIO AND TELEVISION PROGRAMS; LIVE SHOWS FEATURING RUGBY GAMES, RUGBY EXHIBITIONS, RUGBY COMPETITIONS AND MUSICAL, COMEDY AND DANCE PERFORMANCES; SPORTING AND CULTURAL ACTIVITIES, NAMELY, SPORTS CAMPS; ORGANIZING SPORTING EVENTS, NAMELY, RUGBY GAMES BY SCHEDULING GAMES (U.S. CLS. 100, 101 AND 107).

MARK SHINER, EXAMINING ATTORNEY

SN 85-301,148. MCNEILLY, MICHAEL, BEVERLY HILLS, CA. FILED 4-21-2011.

CLASS 25—CLOTHING

FOR MEN'S WOMEN'S AND CHILDREN'S APPAREL AND FOOTWEAR, NAMELY, SHIRTS, SWEATSHIRTS, BLOUSES, SOCKS, SHOES, PANTS, SLACKS, GLOVES, BELTS, AND ATHLETIC UNIFORMS; MEN'S WOMEN'S AND CHILDREN'S CASUAL WEAR; MEN'S WOMEN'S AND CHILDREN'S SPORTS UNIFORMS, SPORT SOUVENIR SPORT JERSEYS; MEN'S WOMEN'S AND CHILDREN'S HATS AND CAPS; MEN'S WOMEN'S AND CHILDREN'S OUTERWEAR, NAMELY, COATS, RAINCOATS, PARKAS, AND JACKETS; MEN'S WOMEN'S AND CHILDREN'S SWIMWEAR (U.S. CLS. 22 AND 39).

BUBBLEHEAD

THE MARK CONSISTS OF STANDARD CHARACTERS WITHOUT CLAIM TO ANY PARTICULAR FONT, STYLE, SIZE, OR COLOR.

OWNER OF U.S. REG. NOS. 2,031,838 AND 2,449,347.

CLASS 35—ADVERTISING AND BUSINESS

FOR MARKETING SERVICES, NAMELY, PROMOTING THE GOODS AND SERVICES OF OTHERS BY ARRANGING FOR SPONSORS TO AFFILIATE THEIR GOODS AND SERVICES WITH VARIOUS RUGBY PERSONALITIES AND/OR THE SPORT OF RUGBY; DISSEMINATION OF ADVERTISING FOR OTHER VIA AN ON-LINE ELECTRONIC COMMUNICATIONS NETWORK; ASSOCIATION SERVICES, NAMELY, PROMOTING THE INTERESTS OF LEAGUE MEMBERS' RUGBY TEAMS AND THE GAME OF RUGBY; WHOLESALE AND RETAIL ON-LINE STORE, TELEPHONE AND ON-LINE ORDERING SERVICES, RETAIL STORE SERVICES, CATALOG ORDERING SERVICES, MAIL ORDER CATALOG SERVICES, ALL FEATURING AUDIO RECORDINGS AND VIDEO RECORDINGS IN THE FIELD OF RUGBY, CLOTHING AND COMPUTER ACCESSORIES; ASSOCIATION SERVICES, NAMELY, PROMOTING THE INTERESTS OF MEMBER RUGBY CLUBS, SCHEDULING GAMES, AND PROMOTING INTEREST IN RUGBY (U.S. CLS. 100, 101 AND 102).

CLASS 9—ELECTRICAL AND SCIENTIFIC APPARATUS

FOR DVDS FEATURING MUSIC, ANIMATION AND LIVE ACTION; AUDIO AND VIDEO RECORDINGS FEATURING MUSIC, ANIMATION AND LIVE ACTION; AUDIO AND VIDEO RECORDINGS FEATURING ANIMATED AND LIVE ACTION TELEVISION SHOWS, ANIMATED AND ACTION MOTION PICTURE FILMS, ANIMATED, ACTION AND DRAMA SHORT FILMS, AND AUDIO AND VIDEO CHILDREN'S STORYBOOKS; MOTION PICTURE FILMS IN THE FIELD OF ANIMATION, ANIMAL, ACTION AND ADVENTURE, DRAMA AND COMEDY; AUDIO AND VIDEO RECORDINGS IN THE NATURE OF COMPUTER GAME PROGRAMS AND ELECTRONIC GAME PROGRAMS; DOWNLOADABLE COMPUTER GAME PROGRAMS, DOWNLOADABLE ELECTRONIC GAME PROGRAMS; DVDS FEATURING GAME SOFTWARE; DOWNLOADABLE AUDIO AND VIDEO RECORDINGS FEATURING MUSIC, ANIMATION, ACTION AND ADVENTURE, DRAMA AND COMEDY FILMS, SHORT FILMS, AND TELEVISION SHOWS; DOWNLOADABLE ELECTRONIC PUBLICATIONS, NAMELY, NEWSLETTERS, NEWSPAPERS, AND MAGAZINES IN THE FIELD OF ENTERTAINMENT, ANIMATION, MOTION PICTURE FILMS, SHORT FILMS, TELEVISION SHOWS, COMEDY, SAFETY AND MUSIC (U.S. CLS. 21, 23, 26, 36 AND 38).

CLASS 16—PAPER GOODS AND PRINTED MATTER

FOR CARTOON PRINTS, CARTOON STRIPS, ANIMATION CELS, COMIC BOOKS, GRAPHIC NOVELS, COMICS, COMIC MAGAZINES, POSTERS, STICKERS, PRINTED PUBLICATIONS, NAMELY, NEWSLETTERS, NEWSPAPERS, AND MAGAZINES IN THE FIELD OF ENTERTAINMENT, ANIMATION, MOTION PICTURE FILMS, SHORT FILMS, TELEVISION SHOWS, COMEDY, SAFETY AND MUSIC; PRINTED AND PAPER GOODS, NAMELY, MURALS, POSTERS, ART PRINTS, ART PICTURES, STICKERS, NOTE CARDS, AND CALENDARS (U.S. CLS. 2, 5, 22, 23, 29, 37, 38 AND 50).

CLASS 25—CLOTHING

FOR CLOTHING, NAMELY, T-SHIRTS, SHIRTS, SWEATSHIRTS, TANK TOPS, TOPS, BOTTOMS, UNDERWEAR, SWIMWEAR, HEADWEAR, FOOTWEAR, JACKETS, VESTS, DRESSES, HALLOWEEN COSTUMES, MASQUERADE COSTUMES, SCARVES, BELTS, SKIRTS, BEACHWEAR, SKI WEAR, BOAS, LINGERIE (U.S. CLS. 22 AND 39).

CLASS 28—TOYS AND SPORTING GOODS

FOR PRINTED AND PAPER GOODS, NAMELY, CARD GAMES, BOARD GAMES, PAPER DOLLS, PAPER AIRPLANES, PAPER FACE MASKS, PRINTED POSITIONAL TOYS AND TOY FIGURES FOR USE IN PUZZLES AND GAMES (U.S. CLS. 22, 23, 38 AND 50).

JOHN HWANG, EXAMINING ATTORNEY

SN 85-301,949. THE DALLAS MORNING NEWS, INC., DALLAS, TX. FILED 4-22-2011.

MyMobileCE

THE MARK CONSISTS OF STANDARD CHARACTERS WITHOUT CLAIM TO ANY PARTICULAR FONT, STYLE, SIZE, OR COLOR.

CLASS 35—ADVERTISING AND BUSINESS

FOR ADVERTISING THE GOODS AND SERVICES OF OTHERS IN PRINT, ON TELEVISION OR RADIO, AND VIA THE INTERNET, MOBILE NETWORKS AND OTHER ELECTRONIC COMMUNICATIONS NETWORKS (U.S. CLS. 100, 101 AND 102).

CLASS 41—EDUCATION AND ENTERTAINMENT

FOR CONTINUING EDUCATION SERVICES, NAMELY, PROVIDING CONTINUING PROFESSIONAL EDUCATION SEMINARS AND TESTING FOR PROFESSIONALS IN THE FIELDS OF HEALTH CARE, MEDICAL, LEGAL, REAL ESTATE, ENGINEERING, ARCHITECTURAL DESIGN, EDUCATION, FINANCE, ACCOUNTING, JOURNALISM, TECHNICAL, COMPUTER, TECHNOLOGY, SCIENCE, PUBLIC ADMINISTRATION, PUBLIC SERVICE, COMMUNITY DEVELOPMENT, FUNDRAISING, INSURANCE, EMPLOYMENT, BUSINESS, EXECUTIVE, MANAGERIAL, INFORMATION MANAGEMENT, TRAVEL AND OTHER PROFESSIONAL FIELDS VIA THE INTERNET, MOBILE NETWORKS AND OTHER ELECTRONIC COMMUNICATIONS NETWORKS (U.S. CLS. 100, 101 AND 107).

JAY FLOWERS, EXAMINING ATTORNEY

SN 85-301,985. DIGITALGLOBE, INC., LONGMONT, CO. FILED 4-22-2011.

FIRSTWATCH

THE MARK CONSISTS OF STANDARD CHARACTERS WITHOUT CLAIM TO ANY PARTICULAR FONT, STYLE, SIZE, OR COLOR.

CLASS 38—COMMUNICATION

FOR PROVIDING EMAIL NOTIFICATION VIA THE INTERNET FOR REAL-TIME UPDATES IN THE FIELD OF GEOSPATIAL IMAGERY RELATING TO NATURAL OR MAN-MADE DISASTERS (U.S. CLS. 100, 101 AND 104).

CLASS 42—SCIENTIFIC AND COMPUTER SERVICES

FOR PROVIDING AN ON-LINE COMPUTER DATABASE IN THE FIELD OF GEOSPATIAL IMAGERY TO PROVIDE RAPID GEOSPATIAL IMAGERY-BASED ANALYSIS OF THE SCOPE, MAGNITUDE, AND INITIAL ASSESSMENT OF CRITICAL INFRASTRUCTURE FOLLOWING A NATURAL OR MAN-MADE DISASTER; PROVIDING SCIENTIFIC ANALYSIS REPORTS FROM GEOSPATIAL IMAGERY FOR RAPID INITIAL ASSESSMENT OF THE CONDITION OF KEY INFRASTRUCTURE NODES WITHIN THE ZONE ASSOCIATED WITH A NATURAL OR MAN-MADE DISASTER (U.S. CLS. 100 AND 101).

REBECCA EISINGER, EXAMINING ATTORNEY

SN 85-302,033. PARKER SYNERGIES LLC, WINDSOR, ONTARIO, CANADA, FILED 4-22-2011.

TRAINING IS MY WEAPON

THE MARK CONSISTS OF STANDARD CHARACTERS WITHOUT CLAIM TO ANY PARTICULAR FONT, STYLE, SIZE, OR COLOR.

CLASS 25—CLOTHING

FOR SHIRTS, JACKETS, PANTS, FOOTWEAR, HATS, GLOVES, SHORTS, DRESSES, SKIRTS, SOCKS, WRIST BANDS, HEAD BANDS (U.S. CLS. 22 AND 39).

CLASS 28—TOYS AND SPORTING GOODS

FOR ANKLE WEIGHTS FOR EXERCISE; ANKLE WEIGHTS FOR ATHLETIC USE; WRIST WEIGHTS FOR EXERCISE; WRIST WEIGHTS FOR ATHLETIC USE; LEG WEIGHTS FOR EXERCISE; LEG WEIGHTS FOR ATHLETIC USE; BAR-BELLS FOR WEIGHT LIFTING; DUMB-BELLS FOR WEIGHT LIFTING; EXERCISE WEIGHTS; WEIGHTS FOR ATHLETIC USE; EXERCISE AND FITNESS EQUIPMENT, NAMELY, WEIGHTS (U.S. CLS. 22, 23, 38 AND 50).

ODESSA BIBBINS, EXAMINING ATTORNEY

SN 85-302,055. CTI TOWERS, INC., FRANKLIN, MA. FILED 4-22-2011.

SN 85-302,552. INNSBROOK OWNERS' ASSOCIATION, INC., GLEN ALLEN, VA. FILED 4-22-2011.

CTI Towers

THE MARK CONSISTS OF STANDARD CHARACTERS WITHOUT CLAIM TO ANY PARTICULAR FONT, STYLE, SIZE, OR COLOR.

NO CLAIM IS MADE TO THE EXCLUSIVE RIGHT TO USE "TOWERS", APART FROM THE MARK AS SHOWN.

CLASS 35—ADVERTISING AND BUSINESS

FOR MANAGING AND OPERATING TELECOMMUNICATIONS TOWERS, DISTRIBUTED ANTENNA SYSTEMS AND PICOCELLS FOR OTHERS (U.S. CLS. 100, 101 AND 102).

CLASS 38—COMMUNICATION

FOR LEASING OF TELECOMMUNICATION FACILITIES AND EQUIPMENT, NAMELY, TELECOMMUNICATIONS TOWERS, DISTRIBUTED ANTENNA SYSTEMS AND PICOCELLS (U.S. CLS. 100, 101 AND 104).

KIMBERLY PERRY, EXAMINING ATTORNEY

SN 85-302,066. CTI TOWERS, INC., FRANKLIN, MA. FILED 4-22-2011.



CTI | TOWERS

NO CLAIM IS MADE TO THE EXCLUSIVE RIGHT TO USE "TOWERS", APART FROM THE MARK AS SHOWN.

THE MARK CONSISTS OF STYLIZED CAPITAL LETTERS "CTI TOWERS" WITH A VERTICAL LINE BETWEEN THE LETTERS "CTI" AND THE WORD "TOWERS". CENTERED ABOVE THE LETTERS IS A TOWER INSIDE A CIRCLE.

CLASS 35—ADVERTISING AND BUSINESS

FOR MANAGING AND OPERATING TELECOMMUNICATIONS TOWERS, DISTRIBUTED ANTENNA SYSTEMS AND PICOCELLS FOR OTHERS (U.S. CLS. 100, 101 AND 102).

CLASS 38—COMMUNICATION

FOR LEASING OF TELECOMMUNICATION FACILITIES AND EQUIPMENT, NAMELY, TELECOMMUNICATIONS TOWERS, DISTRIBUTED ANTENNA SYSTEMS AND PICOCELLS (U.S. CLS. 100, 101 AND 104).

KIMBERLY PERRY, EXAMINING ATTORNEY

INNSBROOK AFTER HOURS

THE MARK CONSISTS OF STANDARD CHARACTERS WITHOUT CLAIM TO ANY PARTICULAR FONT, STYLE, SIZE, OR COLOR.

CLASS 35—ADVERTISING AND BUSINESS

FOR BUSINESS SERVICES, NAMELY, OPERATING CONCERT VENUES FOR PUBLIC CONCERTS FOR OTHERS (U.S. CLS. 100, 101 AND 102).

FIRST USE 5-31-1985; IN COMMERCE 5-31-1985.

CLASS 41—EDUCATION AND ENTERTAINMENT

FOR ENTERTAINMENT SERVICES, NAMELY, ARRANGING AND CONDUCTING CONCERTS AND PRODUCTION OR CO-PRODUCTION OF CONCERTS FOR PUBLIC EXHIBITION AND VIEWING (U.S. CLS. 100, 101 AND 107).

FIRST USE 5-31-1985; IN COMMERCE 5-31-1985.
DANNEAN HETZEL, EXAMINING ATTORNEY

SN 85-302,588. PEACELOVE STUDIOS INC., PAWTUCKET, RI. FILED 4-22-2011.

CREATE PEACE OF MIND

THE MARK CONSISTS OF STANDARD CHARACTERS WITHOUT CLAIM TO ANY PARTICULAR FONT, STYLE, SIZE, OR COLOR.

CLASS 14—JEWELRY

FOR WATCHES, JEWELRY (U.S. CLS. 2, 27, 28 AND 50).

CLASS 16—PAPER GOODS AND PRINTED MATTER

FOR ARTWORK, NAMELY, PRINTS AND PAINTINGS; ART KITS TO CREATE PRINTS AND PAINTINGS; STATIONERY; NOTE CARDS; GREETING CARDS; PRINTED INVITATIONS; INVITATION CARDS; BLANK JOURNALS; DIARIES; SKETCH PADS (U.S. CLS. 2, 5, 22, 23, 29, 37, 38 AND 50).

CLASS 25—CLOTHING

FOR CLOTHING, NAMELY, T-SHIRTS, HOODED SWEATSHIRTS, JACKETS, AND HEADWEAR (U.S. CLS. 22 AND 39).

FIRST USE 3-24-2010; IN COMMERCE 3-24-2010.

CLASS 41—EDUCATION AND ENTERTAINMENT

FOR EDUCATIONAL SERVICES, NAMELY, CONDUCTING CLASSES, SEMINARS, CONFERENCES AND WORKSHOPS IN THE FIELD OF ART (U.S. CLS. 100, 101 AND 107).

FIRST USE 4-23-2010; IN COMMERCE 4-23-2010.
REBECCA EISINGER, EXAMINING ATTORNEY

SN 85-302,603. SEECHANGE HEALTH LLC, MINNETONKA, MN. FILED 4-22-2011.

SEECHANGE HEALTH SOLUTIONS

THE MARK CONSISTS OF STANDARD CHARACTERS WITHOUT CLAIM TO ANY PARTICULAR FONT, STYLE, SIZE, OR COLOR.

OWNER OF U.S. REG. NO. 3,842,381.

NO CLAIM IS MADE TO THE EXCLUSIVE RIGHT TO USE "HEALTH SOLUTIONS", APART FROM THE MARK AS SHOWN.

CLASS 9—ELECTRICAL AND SCIENTIFIC APPARATUS

FOR COMPUTER SOFTWARE FOR USE IN DATABASE MANAGEMENT, USE AS A SPREADSHEET AND WORD PROCESSING, AND DOWNLOADABLE ELECTRONIC FORMS, ALL FOR USE IN THE MEDICAL AND HEALTHCARE FIELDS (U.S. CLS. 21, 23, 26, 36 AND 38).

CLASS 35—ADVERTISING AND BUSINESS

FOR INSURANCE CLAIMS DATA BUSINESS ANALYSIS, RECORD-KEEPING SERVICES FOR USE IN RISK MANAGEMENT AND REGULATORY COMPLIANCE BY INSURERS AND PROFESSIONALS IN THE MEDICAL FIELD; PROVIDING AN INTERNET-BASED DATABASE OF PATIENT MEDICAL INFORMATION DESIGNED TO FACILITATE PATIENT-AUTHORIZED, HIPAA-COMPLIANT SHARING AND MAINTENANCE OF PATIENT MEDICAL INFORMATION AMONGST A PATIENT'S DOCTORS SUCH THAT THIS INFORMATION CAN BE DIRECTLY INSERTED INTO THE DOCTOR'S MEDICAL REPORTS AS A MEANS OF INCREASING MEDICAL RECORD GENERATION EFFICIENCY AND ACCURACY (U.S. CLS. 100, 101 AND 102).

CLASS 36—INSURANCE AND FINANCIAL

FOR INSURANCE ADMINISTRATION; INSURANCE CLAIMS ADMINISTRATION; INSURANCE CLAIMS PROCESSING; INSURANCE CONSULTANCY; INSURANCE CONSULTATION; INSURANCE INFORMATION; INSURANCE UNDERWRITING IN THE FIELD OF HEALTH; PROVIDING INFORMATION IN INSURANCE MATTERS; UNDERWRITING INSURANCE FOR PREPAID HEALTH CARE; HEALTH INSURANCE CLAIMS PROCESSING AND ADMINISTRATION, AND CLAIMS DATA FINANCIAL ANALYSIS; PHARMACY BENEFIT MANAGEMENT SERVICES; HEALTH INSURANCE ADMINISTRATION, NAMELY, ORGANIZING AND ADMINISTERING PROVIDER NETWORKS IN THE FIELD OF MEDICAL, DENTAL, PHARMACY, AND BEHAVIORAL HEALTH CARE; ADMINISTRATION SERVICES IN THE FIELD OF HEALTH CARE INSURANCE; PROVIDING INFORMATION REGARDING HEALTH CARE PROVIDER NETWORKS; ADMINISTRATION OF MEDICAL, DENTAL, PHARMACY, BEHAVIORAL HEALTH AND STOP-LOSS INSURANCE SERVICES, INCLUDING PRE-PAID HEALTH CARE PLANS, HEALTH CARE INDEMNITY PLANS, HEALTH CARE PREFERRED PROVIDER PLANS AND CONSUMER-DIRECTED HEALTH PLANS, FOR OTHERS; INSURANCE ADMINISTRATION IN THE FIELD OF HEALTH; INSURANCE UNDERWRITING IN THE FIELD OF HEALTH INSURANCE PRODUCTS WITH RELATED VALUE-BASED HEALTH PLANS AND PERSONAL HEALTH RECORDS (U.S. CLS. 100, 101 AND 102).

CLASS 42—SCIENTIFIC AND COMPUTER SERVICES

FOR PROVIDING AN INTERACTIVE WEBSITE FEATURING TEMPORARY USE OF NON-DOWNLOADABLE SOFTWARE ALLOWING WEBSITE USERS TO ENTER, ACCESS, TRACK, MONITOR AND GENERATE HEALTH AND MEDICAL INFORMATION AND REPORTS (U.S. CLS. 100 AND 101).

CLASS 44—MEDICAL, BEAUTY AND AGRICULTURAL SERVICES

FOR MAINTAINING FILES AND RECORDS CONCERNING THE MEDICAL CONDITION OF INDIVIDUALS; PROVIDING AN ON-LINE COMPUTER DATABASE AND INTERACTIVE WEBSITE FEATURING INFORMATION REGARDING HEALTHCARE (U.S. CLS. 100 AND 101).

JUSTINE D. PARKER, EXAMINING ATTORNEY

SN 85-302,608. SEECHANGE HEALTH LLC, MINNETONKA, MN. FILED 4-22-2011.

SEECHANGE

THE MARK CONSISTS OF STANDARD CHARACTERS WITHOUT CLAIM TO ANY PARTICULAR FONT, STYLE, SIZE, OR COLOR.

OWNER OF U.S. REG. NO. 3,842,381.

CLASS 9—ELECTRICAL AND SCIENTIFIC APPARATUS

FOR COMPUTER SOFTWARE FOR USE IN DATABASE MANAGEMENT, USE AS A SPREADSHEET AND WORD PROCESSING, AND DOWNLOADABLE ELECTRONIC FORMS, ALL FOR USE IN THE MEDICAL AND HEALTHCARE FIELDS (U.S. CLS. 21, 23, 26, 36 AND 38).

CLASS 42—SCIENTIFIC AND COMPUTER SERVICES

FOR PROVIDING AN INTERACTIVE WEBSITE FEATURING TEMPORARY USE OF NON-DOWNLOADABLE SOFTWARE ALLOWING WEBSITE USERS TO ENTER, ACCESS, TRACK, MONITOR AND GENERATE HEALTH AND MEDICAL INFORMATION AND REPORTS (U.S. CLS. 100 AND 101).

CLASS 44—MEDICAL, BEAUTY AND AGRICULTURAL SERVICES

FOR MAINTAINING FILES AND RECORDS CONCERNING THE MEDICAL CONDITION OF INDIVIDUALS; PROVIDING AN ON-LINE COMPUTER DATABASE AND INTERACTIVE WEBSITE FEATURING INFORMATION REGARDING HEALTHCARE (U.S. CLS. 100 AND 101).

JUSTINE D. PARKER, EXAMINING ATTORNEY

SN 85-302,684. BEYONCÉ, INC., NEW YORK, NY. FILED 4-22-2011.

**PARKWOOD MUSIC
ENTERTAINMENT**

THE MARK CONSISTS OF STANDARD CHARACTERS WITHOUT CLAIM TO ANY PARTICULAR FONT, STYLE, SIZE, OR COLOR.

OWNER OF U.S. REG. NO. 3,755,725.

NO CLAIM IS MADE TO THE EXCLUSIVE RIGHT TO USE "MUSIC ENTERTAINMENT", APART FROM THE MARK AS SHOWN.

CLASS 9—ELECTRICAL AND SCIENTIFIC APPARATUS

FOR MUSICAL SOUND RECORDINGS; MUSICAL VIDEO RECORDINGS; AUDIOVISUAL RECORDINGS FEATURING MUSIC AND MUSICAL BASED ENTERTAINMENT; DOWNLOADABLE MUSICAL SOUND AND DOWNLOADABLE AUDIOVISUAL RECORDINGS FEATURING MUSIC AND MUSICAL BASED ENTERTAINMENT; DOWNLOADABLE RINGTONES, GRAPHICS, SOUND, VIDEOS, GAMES AND MUSIC VIA A GLOBAL COMPUTER NETWORK AND WIRELESS DEVICES; PRE-RECORDED DVDS AND CDS FEATURING MUSIC, MUSICAL PERFORMANCES AND INFORMATION RELATING TO MUSIC AND MUSICAL ENTERTAINMENT; COMPUTER SOFTWARE FOR USE IN CONNECTION WITH THE PROVISION OF INFORMATION RELATING TO MUSIC AND MUSICAL ENTERTAINMENT THAT MAY BE DOWNLOADED FROM GLOBAL COMPUTER NETWORKS (U.S. CLS. 21, 23, 26, 36 AND 38).

CLASS 35—ADVERTISING AND BUSINESS

FOR PRODUCT MERCHANDISING; PROMOTION AND DISTRIBUTORSHIP IN THE FIELD OF SOUND AND/OR VISUAL RECORDINGS; MANAGEMENT OF PERFORMING ARTISTS; COMMERCIAL ADMINISTRATION OF LICENSING OF MUSICAL AND/OR LYRICAL WORKS; DISTRIBUTORSHIP SERVICES IN THE FIELD OF MUSIC AND AUDIO-VISUAL GOODS; DISTRIBUTORSHIP IN THE FIELD OF MUSICAL AND NON-MUSICAL SOUND RECORDINGS AND VIDEO RECORDINGS; ADVERTISING AND PROMOTIONAL SERVICES AND RELATED CONSULTING SERVICES; ADVERTISING AND PUBLICITY SERVICES; ASSOCIATION SERVICES, NAMELY, PROMOTING THE INTERESTS OF MUSICIANS, SINGERS, SONGWRITERS, MUSICAL PERFORMERS AND ARTISTS; COMPUTERIZED ONLINE ORDERING FEATURING GENERAL MERCHANDISE AND GENERAL CONSUMER GOODS; COMPUTERIZED ONLINE ORDERING SERVICES IN THE FIELD OF MUSIC AND ENTERTAINMENT; COMPUTERIZED ONLINE RETAIL STORE SERVICES IN THE FIELD OF MUSIC AND ENTERTAINMENT; MAIL ORDER CATALOG SERVICES FEATURING CD'S, DVD'S AND GENERAL MERCHANDISE; ONLINE RETAIL STORE SERVICES FEATURING DOWNLOADABLE PRE-RECORDED MUSIC AND AUDIO-VISUAL CONTENT AND GENERAL MERCHANDISE; ORGANIZATION OF PROMOTIONS USING AUDIO-VISUAL MEDIA; PROMOTING THE CONCERTS OF OTHERS; PROMOTING THE GOODS AND SERVICES OF OTHERS BY ARRANGING FOR SPONSORS TO AFFILIATE THEIR GOODS AND SERVICES WITH CONCERTS, MUSICAL AND RELATED EVENTS; MANAGEMENT SERVICES FOR PROFESSIONAL ARTISTS; TALENT AGENCY SERVICES; ADVERTISING, INCLUDING PROMOTION OF PRODUCTS AND SERVICES OF THIRD PARTIES THROUGH SPONSORING ARRANGEMENTS AND LICENSE AGREEMENTS RELATING TO MUSIC EVENTS (U.S. CLS. 100, 101 AND 102).

CLASS 38—COMMUNICATION

FOR TELECOMMUNICATIONS SERVICES, NAMELY, TRANSMISSION OF DIGITAL MUSIC (U.S. CLS. 100, 101 AND 104).

CLASS 41—EDUCATION AND ENTERTAINMENT

FOR RECORD PRODUCTION; AUDIO RECORDING AND PRODUCTION; RECORDING STUDIOS; ENTERTAINMENT SERVICES, NAMELY, PRODUCING MUSICAL AUDIO AND VIDEOTAPE RECORDINGS FOR OTHERS; VIDEOTAPE PRODUCTION; MUSIC PUBLISHING SERVICES; ENTERTAINMENT, NAMELY, PRODUCING LIVE MUSICAL PERFORMANCES; MUSICAL ENTERTAINMENT SERVICES, NAMELY, LIVE PERFORMANCES, CONCERTS AND SHOWS; PROVIDING ONLINE ENTERTAINMENT, NAMELY, PROVIDING NONDOWNLOADABLE, PRE-RECORDED OR LIVE SOUND AND AUDIOVISUAL RECORDINGS IN THE FIELD OF MUSIC AND MUSICAL BASED ENTERTAINMENT; PROVIDING A WEBSITE OVER A GLOBAL COMPUTER NETWORK FEATURING INFORMATION ON MUSICAL ARTISTS AND EVENTS; PROVIDING INFORMATION ABOUT PERFORMANCES TO BE GIVEN BY MUSICAL ARTISTS ON TOURS; ENTERTAINMENT SERVICES, NAMELY, PRODUCTION OF TOURS BY MUSICAL ARTISTS; PRODUCTION OF SOUND RECORDINGS; RECORDING STUDIO SERVICES; PROVISION OF STUDIO FOR AUDIO AND VISUAL RECORDING; PROVIDING A WEBSITE OVER A GLOBAL COMPUTER INFORMATION NETWORK FEATURING ENTERTAINMENT INFORMATION ON A RECORD LABEL, ITS ARTISTS, THE MUSIC FEATURED; ENTERTAINMENT SERVICES, NAMELY, PROVIDING ONLINE NON-DOWNLOADABLE PRERECORDED MUSICAL SOUND AND VIDEO RECORDINGS VIA A GLOBAL COMPUTER NETWORK; FAN CLUBS; ENTERTAINMENT SERVICES IN THE NATURE OF LIVE OR PRE-RECORDED PERFORMANCES RENDERED BY MUSICAL ARTISTS THROUGH THE MEDIUM OF TELEVISION, RADIO, AND AUDIO AND VIDEO RECORDINGS; ENTERTAINMENT SERVICES, NAMELY, PERFORMANCES BY MUSICAL ARTISTS RENDERED LIVE AND RECORDED FOR FUTURE DISTRIBUTION;

PROVIDING A WEB SITE FEATURING NON-DOWNLOADABLE MUSICAL PERFORMANCES, MUSICAL VIDEOS, PHOTOGRAPHS, AND OTHER MULTIMEDIA MATERIALS FEATURING MUSIC AND ENTERTAINMENT; ENTERTAINMENT SERVICES, NAMELY, PROVIDING PRERECORDED NON-DOWNLOADABLE MUSIC, INFORMATION IN THE FIELD OF MUSIC, AND COMMENTARY AND ARTICLES ABOUT MUSIC, ALL ONLINE VIA A GLOBAL COMPUTER NETWORK; ONLINE MUSIC SERVICES, NAMELY, PROVIDING ELECTRONIC LIBRARY SERVICES WHICH FEATURE MUSICAL AND NON-MUSICAL SOUND RECORDINGS VIA AN ONLINE COMPUTER NETWORK; PROVIDING AN ONLINE SEARCHABLE DATABASE FEATURING CATALOGED AND INDEXED RECORDED MUSIC AND SOUNDS (U.S. CLS. 100, 101 AND 107).

JORDAN BAKER, EXAMINING ATTORNEY

SN 85-302,878. SION MILOSKY, LLC, LOS ANGELES, CA. FILED 4-23-2011.

SION MILOSKY

THE MARK CONSISTS OF STANDARD CHARACTERS WITHOUT CLAIM TO ANY PARTICULAR FONT, STYLE, SIZE, OR COLOR.

THE NAME "SION MILOSKY" DOES NOT IDENTIFY A LIVING INDIVIDUAL.

CLASS 9—ELECTRICAL AND SCIENTIFIC APPARATUS

FOR DVD CASES AND SLEEVES, CD CASES AND SLEEVES, PRE-RECORDED VIDEO TAPES, CDS AND DVDS FEATURING SPORTS HIGHLIGHTS AND FOOTAGE, DECORATIVE REFRIGERATOR MAGNETS, SUNGLASSES AND SUNGLASS CASES (U.S. CLS. 21, 23, 26, 36 AND 38).

CLASS 16—PAPER GOODS AND PRINTED MATTER

FOR STICKERS, DECALS, PHOTOGRAPHS, BOOKS IN THE FIELD OF SURFING, PAPER BANNERS, POSTERS, NOTE PADS, NOTE CARDS, POST CARDS, STATIONERY, ENVELOPES, ADHESIVE NOTEPADS, FRAMED ART PRINTS, PRINTED TICKETS, BROCHURES ABOUT SURFING, EVENT PROGRAMS, PENCILS, PENS (U.S. CLS. 2, 5, 22, 23, 29, 37, 38 AND 50).

CLASS 36—INSURANCE AND FINANCIAL

FOR CHARITABLE FUNDRAISING SERVICES (U.S. CLS. 100, 101 AND 102).

CLASS 41—EDUCATION AND ENTERTAINMENT

FOR ENTERTAINMENT IN THE NATURE OF COMPETITIONS IN THE FIELD OF SURFING, EDUCATIONAL SERVICES, NAMELY, CONDUCTING PROGRAMS IN THE FIELD OF SURFING, ORGANIZING SPORTS EVENTS IN THE FIELD OF SURFING (U.S. CLS. 100, 101 AND 107).

CHRISTINA SOBRAL, EXAMINING ATTORNEY

SN 85-303,662. LFC ENTERPRISES, INC., IMMOKALEE, FL. FILED 4-25-2011.

refreshingly dependable
Lipoman

THE NAME(S), PORTRAIT(S), AND/OR SIGNATURE(S) SHOWN IN THE MARK DOES NOT IDENTIFY A PARTICULAR LIVING INDIVIDUAL.

THE MARK CONSISTS OF THE WORD "LIPMAN" WITH THE OPEN PORTION OF THE "P" REPLACED BY A STYLIZED TOMATO CENTERED OVER A LONG STEM THAT ENDS WITH A LEAF DESIGN, AND THE WORDS "REFRESHINGLY DEPENDABLE" APPEARING ABOVE AND TO THE RIGHT OF THE TOMATO DESIGN.

CLASS 35—ADVERTISING AND BUSINESS

FOR DISTRIBUTION AND SUPPLY SERVICES, NAMELY, WHOLESALE AND FOOD DISTRIBUTORSHIP SERVICES, NAMELY, WHOLESALE FOOD DISTRIBUTION OF FRESH FRUITS AND VEGETABLES INCLUDING SLICED AND DICED FRESH PRODUCE AT WHOLESALE FOR THE WHOLESALE AND QUICK SERVICE INDUSTRIES (U.S. CLS. 100, 101 AND 102).

FIRST USE 4-19-2011; IN COMMERCE 4-19-2011.

CLASS 39—TRANSPORTATION AND STORAGE

FOR PACKAGING AND RE-PACKAGING OF GOODS TO MEET RETAIL REQUIREMENTS AND FOR TRANSPORT PURPOSES, NAMELY, THE PACKING AND REPACKING OF FRESH FRUITS AND VEGETABLES INCLUDING SLICED AND DICED FRESH PRODUCE FOR THE WHOLESALE AND QUICK SERVICE INDUSTRIES (U.S. CLS. 100 AND 105).

FIRST USE 4-19-2011; IN COMMERCE 4-19-2011.

CLASS 44—MEDICAL, BEAUTY AND AGRICULTURAL SERVICES

FOR CONTRACT FARMING FOR OTHERS OF FRESH FRUITS AND VEGETABLES INCLUDING SLICED AND DICED FRESH PRODUCE FOR THE WHOLESALE AND QUICK SERVICE INDUSTRIES (U.S. CLS. 100 AND 101).

FIRST USE 4-19-2011; IN COMMERCE 4-19-2011.

JAMES STEIN, EXAMINING ATTORNEY

SN 85-304,001. MARSH & MCLENNAN COMPANIES, INC., NEW YORK, NY. FILED 4-25-2011.

PARTNERING FOR IMPACT

THE MARK CONSISTS OF STANDARD CHARACTERS WITHOUT CLAIM TO ANY PARTICULAR FONT, STYLE, SIZE, OR COLOR.

CLASS 35—ADVERTISING AND BUSINESS

FOR BUSINESS SERVICES PROVIDED BY A PARENT COMPANY COMBINING AND LEVERAGING EXPERTISE OF THE SERVICES OF ITS COMPONENT BUSINESSES OFFERING ADVICE AND SOLUTIONS IN THE AREAS OF RISK, STRATEGY, AND HUMAN CAPITAL, NAMELY, BUSINESS MANAGEMENT ADVISORY SERVICES, BUSINESS ADMINISTRATION ASSISTANCE, SPECIALIZED BUSINESS MANAGEMENT AND ECONOMIC CONSULTING SERVICES, BUSINESS RESEARCH AND ANALYSIS, PREPARING BUSINESS AND FINANCIAL REPORTS FOR OTHERS, CONDUCTING TRADE SHOWS IN THE FIELDS OF INSURANCE AND REINSURANCE, BUSINESS RISK, STRATEGY, AND HUMAN CAPITAL, CONDUCTING BUSINESS CONFERENCES, MANAGEMENT AND OPERATION ASSISTANCE TO COMMERCIAL BUSINESSES, AND BUSINESS ADVICE RELATING TO RISK, STRATEGY AND HUMAN CAPITAL, ALL OF THE FOREGOING SERVICES IN THE FIELDS OF RISK AND INSURANCE SERVICES AND CONSULTING SERVICES (U.S. CLS. 100, 101 AND 102).

CLASS 36—INSURANCE AND FINANCIAL

FOR SERVICES PROVIDED BY A PARENT COMPANY COMBINING AND LEVERAGING EXPERTISE OF THE SERVICES OF ITS COMPONENT BUSINESSES OFFERING ADVICE AND SOLUTIONS IN THE AREAS OF RISK, STRATEGY, AND HUMAN CAPITAL, NAMELY, SPECIALIZED FINANCIAL MANAGEMENT SERVICES, FINANCIAL RESEARCH AND ANALYSIS, OFFERING FINANCIAL INVESTMENT ADVICE RELATING TO THE AREAS OF RISK, STRATEGY, AND HUMAN CAPITAL, ALL OF THE FOREGOING SERVICES IN THE FIELDS OF RISK AND INSURANCE SERVICES AND CONSULTING SERVICES (U.S. CLS. 100, 101 AND 102).

TRACY FLETCHER, EXAMINING ATTORNEY

SN 85-304,002. SION MILOSKY, LLC, LOS ANGELES, CA. FILED 4-25-2011.

LIVE LIKE SION

THE MARK CONSISTS OF STANDARD CHARACTERS WITHOUT CLAIM TO ANY PARTICULAR FONT, STYLE, SIZE, OR COLOR.

CLASS 9—ELECTRICAL AND SCIENTIFIC APPARATUS

FOR DVD CASES AND SLEEVES, CD CASES AND SLEEVES, PRE-RECORDED VIDEO TAPES, CDS AND DVDS FEATURING SPORTS HIGHLIGHTS AND FOOTAGE, DECORATIVE REFRIGERATOR MAGNETS, SUNGLASSES AND SUNGLASS CASES (U.S. CLS. 21, 23, 26, 36 AND 38).

CLASS 16—PAPER GOODS AND PRINTED MATTER

FOR STICKERS, DECALS, PHOTOGRAPHS, BOOKS IN THE FIELD OF SURFING, PAPER BANNERS, POSTERS, NOTE PADS, NOTE CARDS, POST CARDS, STATIONERY, ENVELOPES, ADHESIVE NOTEPADS, FRAMED ART PRINTS, PRINTED TICKETS, BROCHURES ABOUT SURFING, PROGRAMS, PENCILS, PENS (U.S. CLS. 2, 5, 22, 23, 29, 37, 38 AND 50).

CLASS 25—CLOTHING

FOR MEN'S, WOMEN'S AND CHILDREN'S CLOTHING, HEADGEAR AND FOOTWEAR, NAMELY, SHORTS, SHIRTS, T-SHIRTS, TANK TOPS, POLO SHIRTS, TOPS, JACKETS, SWEATSHIRTS, SWEAT-PANTS, PANTS, LEGGINGS, BOTTOMS, SWIMWEAR, SWIM TRUNKS, BATHING SUITS, BIKINIS, COVER UPS, SOCKS, UNDERWEAR, BELTS, TIES, VESTS, SKIRTS, DRESSES, PAJAMAS, ROBES; HEADWEAR, NAMELY, HATS, CAPS AND VISORS; AND FOOTWEAR, NAMELY, SHOES, SANDALS, AND SLIPPERS (U.S. CLS. 22 AND 39).

CLASS 36—INSURANCE AND FINANCIAL

FOR CHARITABLE FUNDRAISING SERVICES (U.S. CLS. 100, 101 AND 102).

CLASS 41—EDUCATION AND ENTERTAINMENT

FOR ENTERTAINMENT IN THE NATURE OF COMPETITIONS IN THE FIELD OF SURFING, EDUCATIONAL SERVICES, NAMELY, CONDUCTING PROGRAMS IN THE FIELD OF SURFING, ORGANIZING SPORTS EVENTS IN THE FIELD OF SURFING (U.S. CLS. 100, 101 AND 107).

CHRISTINA SOBRAL, EXAMINING ATTORNEY

SN 85-304,633. COVIDIEN AG, NEUHAUSEN AM RHEINFALL, SWITZERLAND, FILED 4-26-2011.

COVIDIEN

THE MARK CONSISTS OF STANDARD CHARACTERS WITHOUT CLAIM TO ANY PARTICULAR FONT, STYLE, SIZE, OR COLOR.

OWNER OF SWITZERLAND REG. NO. 614291, DATED 4-18-2011, EXPIRES 4-8-2021.

OWNER OF U.S. REG. NOS. 3,728,373, 3,997,421 AND OTHERS.

CLASS 35—ADVERTISING AND BUSINESS

FOR PROMOTING PUBLIC AWARENESS OF ENVIRONMENTAL MATTERS; PROMOTING PUBLIC AWARENESS OF PROPER MEDICAL WASTE DISPOSAL; PROMOTING PUBLIC AWARENESS OF BARIATRIC MEDICAL PROCEDURES; PROMOTING PUBLIC AWARENESS OF INFECTION PREVENTION IN HOSPITALS (U.S. CLS. 100, 101 AND 102).

CLASS 36—INSURANCE AND FINANCIAL

FOR FINANCIAL SERVICES, NAMELY, PROVIDING CAPITAL TO COMPANIES IN THE HEALTHCARE FIELD; PROVIDING EXTENDED WARRANTIES FOR MEDICAL PRODUCTS; EXTENDED WARRANTY SERVICES, NAMELY, SERVICE CONTRACTS; CHARITABLE FOUNDATION SERVICES, NAMELY, PROVIDING FINANCIAL ASSISTANCE FOR PROGRAMS AND SERVICES OF OTHERS; CHARITABLE SERVICES IN THE FIELD OF MONETARY DONATIONS; FINANCIAL SPONSORSHIP OF SPORTING EVENTS, SYMPOSIUMS, EXPOSITIONS; PROVIDING EDUCATIONAL SCHOLARSHIPS AND SURGICAL FELLOWSHIPS; PROVIDING GRANTS FOR MEDICAL AND SCIENTIFIC EDUCATION AND RESEARCH; PROVIDING GRANTS TO ORGANIZATIONS DEDICATED TO INCREASING ACCESS TO QUALITY HEALTHCARE, PROVIDING GRANTS TO ORGANIZATIONS DEDICATED TO BENEFITING THE HEALTH OF PARTICULAR COMMUNITIES; PROVIDING GRANTS TO ORGANIZATIONS DEDICATED TO SUPPORTING THE DEVELOPMENT OF NEW TREATMENTS FOR OR NEW APPROACHES TO THE PREVENTION OF HEALTH PROBLEMS; PROVIDING GRANTS TO ORGANIZERS OF CONFERENCES AND MEETINGS IN THE MEDICAL FIELD; PROVIDING GRANTS TO TRAINING INSTITUTES IN THE MEDICAL FIELD (U.S. CLS. 100, 101 AND 102).

CLASS 37—CONSTRUCTION AND REPAIR

FOR PROVIDING INFORMATION REGARDING THE RISKS, PROPER USES AND DISPOSAL OF HAZARDOUS SUBSTANCES; TECHNICAL SUPPORT SERVICES, NAMELY, TROUBLESHOOTING IN THE NATURE OF REPAIR OF MEDICAL EQUIPMENT; MAINTENANCE AND REPAIR OF MEDICAL EQUIPMENT; PROVIDING TEMPORARY RENTAL OF MEDICAL EQUIPMENT (U.S. CLS. 100, 103 AND 106).

CLASS 38—COMMUNICATION

FOR PROVIDING ACCESS TO THE INTERNET IN WHICH USERS CAN ACCESS CLINICAL STUDIES, CASE STUDIES, WHITE PAPERS, AND REFERENCE GUIDES IN THE MEDICAL FIELD (U.S. CLS. 100, 101 AND 104).

CLASS 40—MATERIAL TREATMENT

FOR CUSTOM PHARMACEUTICAL MANUFACTURING SERVICES; RECYCLING OF MEDICAL PRODUCTS FOR THE RE-MANUFACTURE AND REUSE OF THE PRODUCTS (U.S. CLS. 100, 103 AND 106).

CLASS 41—EDUCATION AND ENTERTAINMENT

FOR EDUCATIONAL SERVICES, NAMELY, DEVELOPING, ARRANGING, AND CONDUCTING EDUCATIONAL CONFERENCES AND PROGRAMS AND PROVIDING COURSES OF INSTRUCTION IN THE FIELDS OF HUMAN HEALTH, HEALTHCARE, PHARMACEUTICALS, MEDICAL DEVICES, MEDICAL RESEARCH, SURGERY, MEDICAL SCIENCE AND MEDICINE; DISTRIBUTION OF COURSE MATERIALS IN CONNECTION THEREWITH; EDUCATIONAL SERVICES, NAMELY, MENTORING IN THE FIELD OF SURGERY AND WOUND-CARE MANAGEMENT; CONTINUING EDUCATION SERVICES, NAMELY, PROVIDING LIVE AND ON-LINE CONTINUING PROFESSIONAL EDUCATION SEMINARS IN THE MEDICAL FIELD; TRAINING IN THE USE OF MEDICAL EQUIPMENT; MEDICAL AND SURGICAL TRAINING AND TEACHING (U.S. CLS. 100, 101 AND 107).

CLASS 42—SCIENTIFIC AND COMPUTER SERVICES

FOR COMPUTER SERVICES, NAMELY, CREATING AN ONLINE COMMUNITY FOR PATIENTS AND HEALTH CARE PROFESSIONALS TO SHARE INFORMATION REGARDING MEDICAL PROCEDURES; PROVIDING AN INTERACTIVE WEBSITE THAT ENABLES USERS TO ACCESS CLINICAL STUDIES, WHITE PAPERS, AND REFERENCE GUIDES IN THE MEDICAL FIELD (U.S. CLS. 100 AND 101).

CLASS 44—MEDICAL, BEAUTY AND AGRICULTURAL SERVICES

FOR PROVIDING INFORMATION IN THE FIELD OF MINIMALLY INVASIVE SURGERY; PROVIDING MEDICAL INFORMATION; PROVIDING AN INTERNET WEBSITE FOR MEDICAL PROFESSIONALS AND PATIENTS FEATURING MEDICAL INFORMATION FROM REMOTE LOCATIONS VIA ELECTRONIC PATIENT MONITORING DEVICES THAT FEED INFORMATION TO THE WEBSITE THAT CAN BE ACCESSED IN REAL-TIME BY MEDICAL PROFESSIONALS FOR PURPOSES OF MONITORING AND DIAGNOSING MEDICAL CONDITIONS; PROVIDING INFORMATION IN THE FIELD OF BARIATRIC MEDICAL PROCEDURES; PROVIDING INFORMATION, ADVICE AND DATA ON MEDICAL IMAGING; PROVIDING MEDICAL INFORMATION, CONSULTANCY AND ADVISORY SERVICES; MEDICAL DIAGNOSTIC SERVICES; MEDICAL IMAGING SERVICES; CHARITABLE SERVICES IN THE FIELD OF MEDICINE AND MEDICAL PRODUCT DONATIONS; PHILANTHROPIC SERVICES CONCERNING MONETARY DONATIONS; PHILANTHROPIC SERVICES IN THE AREA OF MEDICINE AND MEDICAL PRODUCTS TO VICTIMS OF DISASTERS AND HUMANITARIAN CRISES; PHILANTHROPIC SERVICES IN THE AREA OF MEDICINE AND MEDICAL PRODUCTS FOR MEDICAL MISSIONS (U.S. CLS. 100 AND 101).

CLASS 45—PERSONAL AND LEGAL SERVICES

FOR PROVIDING INFORMATION CONCERNING MEDICAL PRODUCT SAFETY; PROVIDING PERSONAL SUPPORT SERVICES FOR PATIENTS AND THEIR FAMILIES, NAMELY, PROVIDING FOLLOW-UP INFORMATION TO PATIENTS AFTER SURGERY (U.S. CLS. 100 AND 101).

DANNEAN HETZEL, EXAMINING ATTORNEY

SN 85-305,010. MISSION OF MERMAIDS, LLC, NEW YORK, NY. FILED 4-26-2011.

MISSION OF MERMAIDS

THE MARK CONSISTS OF STANDARD CHARACTERS WITHOUT CLAIM TO ANY PARTICULAR FONT, STYLE, SIZE, OR COLOR.

CLASS 25—CLOTHING

FOR CLOTHING, NAMELY, T-SHIRTS; HEADWEAR, NAMELY, CAPS, HATS (U.S. CLS. 22 AND 39).

CLASS 41—EDUCATION AND ENTERTAINMENT

FOR MOTION FILM AND VIDEO FILM PRODUCTION, EDITING AND DISTRIBUTION (U.S. CLS. 100, 101 AND 107).

GRETTA YAO, EXAMINING ATTORNEY

SN 85-305,067. FREELANCE.MAN LIMITED, DOUGLAS, ISLE OF MAN, FILED 4-26-2011.

SN 85-305,096. MISSION OF MERMAIDS, LLC, NEW YORK, NY. FILED 4-26-2011.



NO CLAIM IS MADE TO THE EXCLUSIVE RIGHT TO USE "FREELANCE.COM", APART FROM THE MARK AS SHOWN.

THE COLOR(S) GRAY AND YELLOW IS/ARE CLAIMED AS A FEATURE OF THE MARK.

THE MARK CONSISTS OF THE WORDING "FREELANCE.COM" IN GRAY, WITH THE 'DOT' IN YELLOW; BELOW THIS IS THE WORDING "IT'S TIME TO WORK DIFFERENTLY" IN YELLOW; TO THE LEFT OF "FREELANCE.COM" IS A STYLIZED IMAGE OF A PERSON IN GRAY WITH A YELLOW CURVED LINE PARALLEL TO THE 'LEGS' OF THE PERSON AND A GRAY CURVED LINE PARTIALLY ENCLOSING THE FIGURE.

CLASS 35—ADVERTISING AND BUSINESS

FOR RESEARCH IN THE FIELD OF EMPLOYMENT, NAMELY, IDENTIFICATION OF JOB OPPORTUNITIES FOR QUALIFIED PERSONS AND CONTRACTORS; EMPLOYMENT COUNSELING AND RECRUITING; EMPLOYMENT STAFFING CONSULTATION SERVICES; TESTING TO DETERMINE INDIVIDUAL SKILLS AND QUALIFICATIONS FOR THE PURPOSE OF EMPLOYMENT; BUSINESS CONSULTATION AND BUSINESS MANAGEMENT IN A WIDE VARIETY OF FIELDS SUCH AS ENGINEERING, INFORMATION TECHNOLOGY, INDUSTRIAL SERVICES, TRAINING, COMMUNICATIONS, INSURANCE, STYLING, DATA PROCESSING, MEDICINE, SCIENCE, AVIATION, FINANCE, TOURISM; PROVIDING ONLINE INFORMATION IN THE FIELDS OF EMPLOYMENT PLACEMENT, EMPLOYMENT TESTING, CAREER SELECTION; PROVIDING ONLINE CAREER INFORMATION; PROVIDING ONLINE INFORMATION IN THE FIELDS OF BUSINESS MANAGEMENT AND BUSINESS CONSULTATION (U.S. CLS. 100, 101 AND 102).

CLASS 41—EDUCATION AND ENTERTAINMENT

FOR PROVIDING TRAINING IN THE FIELD OF CAREER SELECTION, PERSONAL AND PROFESSIONAL SKILLS SELF-ASSESSMENT AND JOB SEARCH STRATEGIES; CAREER COUNSELING; PROVIDING TRAINING FOR OTHERS IN THE FIELD OF EMPLOYMENT TESTING; PROFESSIONAL CONSULTATION IN THE FIELD OF TRAINING; PROVIDING ONLINE INFORMATION IN THE FIELD OF EMPLOYMENT TRAINING (U.S. CLS. 100, 101 AND 107).

CLASS 42—SCIENTIFIC AND COMPUTER SERVICES

FOR PROFESSIONAL CONSULTANCY IN INTELLECTUAL AND INDUSTRIAL FIELDS, NAMELY, INFORMATION TECHNOLOGY, ENGINEERING, PRODUCT DESIGN AND GRAPHIC DESIGN; PROVIDING ONLINE INFORMATION IN THE FIELDS OF INFORMATION TECHNOLOGY, ENGINEERING, PRODUCT DESIGN AND GRAPHIC DESIGN (U.S. CLS. 100 AND 101). ELLEN BURNS, EXAMINING ATTORNEY

SUSAN ROCKEFELLER DESIGNS

THE MARK CONSISTS OF STANDARD CHARACTERS WITHOUT CLAIM TO ANY PARTICULAR FONT, STYLE, SIZE, OR COLOR.

NO CLAIM IS MADE TO THE EXCLUSIVE RIGHT TO USE "DESIGNS", APART FROM THE MARK AS SHOWN.

THE NAME "SUSAN ROCKEFELLER" IDENTIFIES A LIVING INDIVIDUAL WHOSE CONSENT IS OF RECORD.

CLASS 14—JEWELRY

FOR JEWELRY (U.S. CLS. 2, 27, 28 AND 50).

CLASS 42—SCIENTIFIC AND COMPUTER SERVICES

FOR JEWELRY DESIGN SERVICES (U.S. CLS. 100 AND 101).

GRETTA YAO, EXAMINING ATTORNEY

SN 85-305,401. ADVENTURES IN MISSIONS, GAINESVILLE, GA. FILED 4-26-2011.

THE WORLD RACE

THE MARK CONSISTS OF STANDARD CHARACTERS WITHOUT CLAIM TO ANY PARTICULAR FONT, STYLE, SIZE, OR COLOR.

CLASS 39—TRANSPORTATION AND STORAGE

FOR ARRANGING, ORGANIZING AND CONDUCTING OVERSEAS TRIPS FOR THE PURPOSES OF CARRYING OUT CHRISTIAN EVANGELISTIC MINISTERIAL SERVICES (U.S. CLS. 100 AND 105).

FIRST USE 4-1-2005; IN COMMERCE 4-1-2005.

CLASS 41—EDUCATION AND ENTERTAINMENT

FOR EDUCATION SERVICES, NAMELY, PROVIDING CLASSES, SEMINARS, AND WORKSHOPS IN THE FIELD OF INTERNATIONAL CHRISTIAN MINISTERIAL AND EVANGELISM FOR THE PURPOSES OF TRAINING INDIVIDUALS TO CARRY OUT MINISTERIAL AND EVANGELISTIC SERVICES OVERSEAS (U.S. CLS. 100, 101 AND 107).

FIRST USE 4-1-2005; IN COMMERCE 4-1-2005.

CLASS 45—PERSONAL AND LEGAL SERVICES

FOR CHRISTIAN MINISTRY SERVICES; EVANGELISTIC AND MINISTERIAL SERVICES (U.S. CLS. 100 AND 101).

FIRST USE 4-1-2005; IN COMMERCE 4-1-2005.

GIANCARLO CASTRO, EXAMINING ATTORNEY

SN 85-306,394. BALLARD FISH & OYSTER CO., INC., TA
CHERRYSTONE AQUA-FARMS, CHERITON, VA. FILED
4-27-2011.

SN 85-307,297. PHOTOGRAPHIC RESEARCH ORGANIZA-
TION, INC., FAIRFIELD, CT. FILED 4-28-2011.

Watch House Point

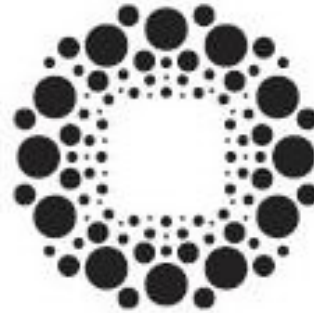

THE MARK CONSISTS OF STANDARD CHARACTERS
WITHOUT CLAIM TO ANY PARTICULAR FONT, STYLE,
SIZE, OR COLOR.

CLASS 29—MEATS AND PROCESSED FOODS

FOR SHELLFISH FOR HUMAN CONSUMPTION; OY-
STERS, NOT LIVE, FOR HUMAN CONSUMPTION (U.S.
CL. 46).

CLASS 31—NATURAL AGRICULTURAL PRO- DUCTS

FOR LIVE OYSTERS (U.S. CLS. 1 AND 46).
HOWARD SMIGA, EXAMINING ATTORNEY

OWNER OF U.S. REG. NOS. 17,756, 3,510,334 AND
OTHERS.

THE MARK CONSISTS OF A CIRCULAR RING MADE
OF CIRCLES OF VARYING SIZES WITH THE CIRCULAR
RING SURROUNDING A SQUARE.

CLASS 2—PAINTS

FOR COATINGS FOR OPTICAL LENSES AND BINO-
CULAR LENSES (U.S. CLS. 6, 11 AND 16).

CLASS 9—ELECTRICAL AND SCIENTIFIC APPARATUS

FOR TRIPODS FOR CAMERAS; TRIPOD BAGS,
MONOPODS; STUDIO LIGHTS FOR USE IN PHOTO-
GRAPHY, REFLECTORS, UMBRELLAS FOR CAMERAS,
LENS CAPS, LENS HOODS AND REMOTE RELEASES;
CAMERAS AND CAMERA EQUIPMENT, NAMELY,
STILL CAMERAS, CAMERA LENSES, EXPOSURE ME-
TERS, ELECTRONIC CAMERA FLASHES, ANTI-GLARE
FILTERS; AND BINOCULARS; DIGITAL PHOTOGRA-
PHY ACCESSORIES, NAMELY, COMPACT CAMERA
FLASHES, OPTICAL FILTERS, FLASH MEMORY
CARDS, BLANK CD-REWRITEABLE DISCS, BLANK
DVD REWRITEABLE DISCS, USB FLASH CARD READ-
ERS, AND CAMERA BATTERIES; AND MEDIA STO-
RAGE CASES, NAMELY, CD STORAGE WALLETS AND
FLASH MEMORY CARD STORAGE WALLETS FOR
STORING MEDIA THAT IS USED WITH DIGITAL
CAMERAS, COMPUTERS AND PRINTERS (U.S. CLS.
21, 23, 26, 36 AND 38).

CLASS 16—PAPER GOODS AND PRINTED MATTER

FOR PRINTING PAPER FOR USE WITH COMPUTER
PRINTERS (U.S. CLS. 2, 5, 22, 23, 29, 37, 38 AND 50).
DEZMONA MIZELLE, EXAMINING ATTORNEY

SN 85-306,473. SAN ANTONIO LIVESTOCK EXPOSITION,
INC., SAN ANTONIO, TX. FILED 4-27-2011.



THE MARK CONSISTS OF THE LETTER "S" DESIGNED
TO FORM A COWBOY HAT.

CLASS 14—JEWELRY

FOR JEWELRY (U.S. CLS. 2, 27, 28 AND 50).
FIRST USE 2-28-2003; IN COMMERCE 2-28-2003.

CLASS 26—FANCY GOODS

FOR BELT BUCKLES (U.S. CLS. 37, 39, 40, 42 AND 50).
FIRST USE 2-28-2003; IN COMMERCE 2-28-2003.
THEODORE MCBRIDE, EXAMINING ATTORNEY

SN 85-307,431. PORTE BROWN LLC, ELK GROVE VILLAGE,
IL. FILED 4-28-2011.

Porte Brown

THE MARK CONSISTS OF STANDARD CHARACTERS
WITHOUT CLAIM TO ANY PARTICULAR FONT, STYLE,
SIZE, OR COLOR.

CLASS 35—ADVERTISING AND BUSINESS

FOR AUDIT SUPPORT SERVICES, NAMELY, CONDUCTING FINANCIAL ACCOUNT AUDITS AND PROVIDING ADVICE ON GOVERNMENT AUDIT PROCESSES, POLICY AND STRATEGY; ACCOUNTING SERVICES, NAMELY, PREPARATION, ANALYSIS AND REVIEW OF FINANCIAL STATEMENTS FOR BUSINESSES AND GENERAL LEDGER MAINTENANCE IN THE NATURE OF BOOKKEEPING; TAX SERVICES, NAMELY, TAX PLANNING, TAX CONSULTATION, AND PREPARATION OF TAX RETURNS FOR INDIVIDUALS, BUSINESSES AND NON-PROFITS (U.S. CLS. 100, 101 AND 102).

FIRST USE 8-15-1974; IN COMMERCE 8-15-1974.

CLASS 36—INSURANCE AND FINANCIAL

FOR CONSULTING SERVICES, NAMELY, PREPARING FINANCIAL VALUATIONS OF COMPANIES AND ASSETS, FINANCIAL DUE DILIGENCE, AND PLANNING FOR ESTATES AND TRUSTS; FINANCIAL CONSULTING FOR RETIREMENT; HEALTH INSURANCE BENEFIT PLAN CONSULTING; WEALTH MANAGEMENT CONSULTING (U.S. CLS. 100, 101 AND 102).

FIRST USE 8-15-1974; IN COMMERCE 8-15-1974.

KATHERINE CHANG, EXAMINING ATTORNEY

CLASS 9—ELECTRICAL AND SCIENTIFIC APPARATUS

FOR AUDIO RECORDINGS AND VIDEO RECORDINGS IN THE FIELD OF RUGBY; PRERECORDED CDS, DVDS, AND HIGH DEFINITION DIGITAL DISCS FEATURING THE SPORT OF RUGBY; COMPUTER GAME SOFTWARE AND DISKS; VIDEO GAME SOFTWARE, VIDEO GAME CARTRIDGES, AND VIDEO GAME MACHINES FOR USE WITH EXTERNAL DISPLAY SCREEN OR MONITOR; COMPUTER SOFTWARE, NAMELY, SCREEN SAVERS FEATURING RUGBY THEMES; DOWNLOADABLE VIDEO RECORDINGS, VIDEO STREAM RECORDINGS, AND AUDIO RECORDINGS IN THE FIELD OF RUGBY PROVIDED OVER THE INTERNET; DOWNLOADABLE COMPUTER SOFTWARE FOR VIEWING DATABASES OF INFORMATION, STATISTICAL INFORMATION, TRIVIA, POLLING INFORMATION AND INTERACTIVE POLLING IN THE FIELD OF RUGBY PROVIDED OVER THE INTERNET; VIDEO GAMES FOR MOBILE DEVICES, PERSONAL COMPUTERS, CONSOLES, TABLETS; ELECTRONIC GAME PROGRAMS; DOWNLOADABLE ELECTRONIC GAME PROGRAMS; ELECTRONIC GAME SOFTWARE; COMPUTER GAME PROGRAMS; DOWNLOADABLE COMPUTER GAME PROGRAMS; INTERACTIVE GAME PROGRAMS; INTERACTIVE GAME SOFTWARE; APPARATUS FOR GAMES ADAPTED FOR USE WITH TELEVISION RECEIVERS; DOWNLOADABLE COMPUTER SOFTWARE FOR USE AS SCREENSAVERS, WALLPAPER, BROWSERS, SKINS, AVATARS AND CURSORS, PROVIDED OVER THE INTERNET; DOWNLOADABLE ELECTRONIC PUBLICATIONS IN THE NATURE OF MAGAZINES, NEWSLETTERS, COLORING BOOKS, GAME SCHEDULES ALL IN THE FIELD OF RUGBY PROVIDED OVER THE INTERNET; DOWNLOADABLE CATALOGS PROVIDED OVER THE INTERNET FEATURING AN ARRAY OF RUGBY-THEMED PRODUCTS (U.S. CLS. 21, 23, 26, 36 AND 38).

CLASS 16—PAPER GOODS AND PRINTED MATTER

FOR POSTERS, CALENDARS, TRADING CARDS, SERIES OF BOOKS RELATING TO RUGBY; MAGAZINES RELATING TO RUGBY; NEWSLETTERS RELATING TO RUGBY; PRINTED TICKETS TO SPORTS GAMES AND EVENTS; PICTORIAL PRINTS, PICTURE POSTCARDS, ART PICTURES, STATIONERY, ENVELOPES, STATIONERY-TYPE PORTFOLIOS; COLLECTIBLE TRADING CARDS; HOLDERS SPECIFICALLY ADAPTED FOR HOLDING COLLECTIBLE TRADING CARDS; SOUVENIR PROGRAMS FOR SPORTS EVENTS (U.S. CLS. 2, 5, 22, 23, 29, 37, 38 AND 50).

CLASS 18—LEATHER GOODS

FOR SOFT LUGGAGE AND BAGS, NAMELY, ATHLETIC, DUFFEL, TOTE, AND ALL-PURPOSE SPORTS BAGS, BACK PACKS, KNAPSACKS, WAIST PACKS, GYM BAGS, GARMENT BAGS FOR TRAVEL, WALLET, KEY CASES, LUGGAGE TAGS, BILLFOLDS AND UMBRELLAS (U.S. CLS. 1, 2, 3, 22 AND 41).

CLASS 25—CLOTHING

FOR MEN'S, WOMEN'S AND CHILDREN'S CASUAL WEAR, NAMELY, T-SHIRTS, SWEATSHIRTS, PANTS; MEN'S, WOMEN'S AND CHILDREN'S SPORTS UNIFORMS, NAMELY, SPORTS JERSEYS AND SOUVENIR SPORTS JERSEYS; MEN'S, WOMEN'S AND CHILDREN'S HATS AND CAPS; MEN'S, WOMEN'S AND CHILDREN'S OUTERWEAR, NAMELY, SWEATSHIRTS AND JACKETS; MEN'S WOMEN'S AND CHILDREN'S SWIMWEAR; MEN'S, WOMEN'S AND CHILDREN'S FOOTWEAR, NAMELY, SPORTS FOOTWEAR (U.S. CLS. 22 AND 39).

SN 85-307,872. RUGBY NATION, LLC, SEATTLE, WA. FILED 4-28-2011.

SEREVI

THE MARK CONSISTS OF STANDARD CHARACTERS WITHOUT CLAIM TO ANY PARTICULAR FONT, STYLE, SIZE, OR COLOR.

THE NAME(S), PORTRAIT(S), AND/OR SIGNATURE(S) SHOWN IN THE MARK IDENTIFIES WAISALE "SEREVI", WHOSE CONSENT(S) TO REGISTER IS MADE OF RECORD.

CLASS 28—TOYS AND SPORTING GOODS

FOR TOYS, GAMES AND SPORTING GOODS, NAMELY, RUGBY BALLS, HEAD GUARDS FOR RUGBY TRAINING PURPOSES, BLOCKING BAGS, CONES AND OTHER SPECIALLY ADAPTED EQUIPMENT USED FOR THE SPORT OF RUGBY (U.S. CLS. 22, 23, 38 AND 50).

CLASS 41—EDUCATION AND ENTERTAINMENT

FOR EDUCATION AND ENTERTAINMENT SERVICES IN THE NATURE OF ORGANIZING AND CONDUCTING PROFESSIONAL RUGBY GAMES AND EXHIBITIONS; PROVIDING SPORTS AND ENTERTAINMENT INFORMATION VIA A GLOBAL COMPUTER NETWORK OR A COMMERCIAL ON-LINE COMPUTER SERVICE OR BY CABLE, SATELLITE, TELEVISION AND RADIO; ARRANGING AND CONDUCTING ATHLETIC COMPETITIONS, NAMELY, PROFESSIONAL RUGBY GAMES AND EXHIBITIONS; RUGBY FAN CLUB SERVICES; ENTERTAINMENT SERVICES, NAMELY, LIVE MUSICAL AND DANCE PERFORMANCES PROVIDED DURING INTERVALS AT SPORTS EVENTS; EDUCATIONAL SERVICES, NAMELY, PHYSICAL EDUCATION PROGRAMS; PRODUCTION OF RADIO AND TELEVISION PROGRAMS; ENTERTAINMENT SERVICES, NAMELY, PERSONAL APPEARANCES BY A PROFESSIONAL RUGBY PLAYER PROMOTING INTEREST IN RUGBY (U.S. CLS. 100, 101 AND 107).

EMILY CHUO, EXAMINING ATTORNEY

CLASS 9—ELECTRICAL AND SCIENTIFIC APPARATUS

FOR AUDIO RECORDINGS AND VIDEO RECORDINGS IN THE FIELD OF RUGBY; PRERECORDED CDS, DVDS, AND HIGH DEFINITION DIGITAL DISCS FEATURING THE SPORT OF RUGBY; COMPUTER GAME SOFTWARE AND DISKS; VIDEO GAME SOFTWARE, VIDEO GAME CARTRIDGES, AND VIDEO GAME MACHINES FOR USE WITH EXTERNAL DISPLAY SCREEN OR MONITOR; COMPUTER SOFTWARE, NAMELY, SCREEN SAVERS FEATURING RUGBY THEMES; DOWNLOADABLE VIDEO RECORDINGS, VIDEO STREAM RECORDINGS, AND AUDIO RECORDINGS IN THE FIELD OF RUGBY PROVIDED OVER THE INTERNET; DOWNLOADABLE COMPUTER SOFTWARE FOR VIEWING DATABASES OF INFORMATION, STATISTICAL INFORMATION, TRIVIA, POLLING INFORMATION AND INTERACTIVE POLLING IN THE FIELD OF RUGBY PROVIDED OVER THE INTERNET; VIDEO GAMES FOR MOBILE DEVICES, PERSONAL COMPUTERS, CONSOLES, TABLETS; ELECTRONIC GAME PROGRAMS; DOWNLOADABLE ELECTRONIC GAME PROGRAMS; ELECTRONIC GAME SOFTWARE; COMPUTER GAME PROGRAMS; DOWNLOADABLE COMPUTER GAME PROGRAMS; INTERACTIVE GAME PROGRAMS; INTERACTIVE GAME SOFTWARE; APPARATUS FOR GAMES ADAPTED FOR USE WITH TELEVISION RECEIVERS; DOWNLOADABLE COMPUTER SOFTWARE FOR USE AS SCREENSAVERS, WALLPAPER, BROWSERS, SKINS, AVATARS AND CURSORS, PROVIDED OVER THE INTERNET; DOWNLOADABLE ELECTRONIC PUBLICATIONS IN THE NATURE OF MAGAZINES, NEWSLETTERS, COLORING BOOKS, GAME SCHEDULES ALL IN THE FIELD OF RUGBY PROVIDED OVER THE INTERNET; DOWNLOADABLE CATALOGS PROVIDED OVER THE INTERNET FEATURING AN ARRAY OF RUGBY-THEMED PRODUCTS (U.S. CLS. 21, 23, 26, 36 AND 38).

CLASS 16—PAPER GOODS AND PRINTED MATTER

FOR POSTERS, CALENDARS, TRADING CARDS, SERIES OF BOOKS RELATING TO RUGBY; MAGAZINES RELATING TO RUGBY; NEWSLETTERS RELATING TO RUGBY; PRINTED TICKETS TO SPORTS GAMES AND EVENTS; PICTORIAL PRINTS, PICTURE POSTCARDS, ART PICTURES, STATIONERY, ENVELOPES, STATIONERY-TYPE PORTFOLIOS; COLLECTIBLE TRADING CARDS; HOLDERS SPECIFICALLY ADAPTED FOR HOLDING COLLECTIBLE TRADING CARDS; SOUVENIR PROGRAMS FOR SPORTS EVENTS (U.S. CLS. 2, 5, 22, 23, 29, 37, 38 AND 50).

CLASS 18—LEATHER GOODS

FOR SOFT LUGGAGE AND BAGS, NAMELY, ATHLETIC, DUFFEL, TOTE, AND ALL-PURPOSE SPORTS BAGS, BACK PACKS, KNAPSACKS, WAIST PACKS, GYM BAGS, GARMENT BAGS FOR TRAVEL, WALLET, KEY CASES, LUGGAGE TAGS, BILLFOLDS AND UMBRELLAS (U.S. CLS. 1, 2, 3, 22 AND 41).

CLASS 25—CLOTHING

FOR MEN'S, WOMEN'S AND CHILDREN'S CASUAL WEAR, NAMELY, T-SHIRTS, SWEATSHIRTS, PANTS; MEN'S, WOMEN'S AND CHILDREN'S SPORTS UNIFORMS, NAMELY, SPORTS JERSEYS AND SOUVENIR SPORTS JERSEYS; MEN'S, WOMEN'S AND CHILDREN'S HATS AND CAPS; MEN'S, WOMEN'S AND CHILDREN'S OUTERWEAR, NAMELY, SWEATSHIRTS AND JACKETS; MEN'S WOMEN'S AND CHILDREN'S SWIMWEAR; MEN'S, WOMEN'S AND CHILDREN'S FOOTWEAR, NAMELY, SPORTS FOOTWEAR (U.S. CLS. 22 AND 39).

SN 85-307,890. RUGBY NATION, LLC, SEATTLE, WA.
FILED 4-28-2011.



THE NAME(S), PORTRAIT(S), AND/OR SIGNATURE(S) SHOWN IN THE MARK IDENTIFIES WAISALE "SEREVI", WHOSE CONSENT(S) TO REGISTER IS MADE OF RECORD.

THE MARK CONSISTS OF THE WORD "SEREVI" TOPPED ON THE UPPER RIGHT SIDE BY A CROWN OPEN AT THE TOP.

CLASS 28—TOYS AND SPORTING GOODS

FOR TOYS, GAMES AND SPORTING GOODS, NAMELY, RUGBY BALLS, HEAD GUARDS FOR RUGBY TRAINING PURPOSES, BLOCKING BAGS, CONES AND OTHER SPECIALLY ADAPTED EQUIPMENT USED FOR THE SPORT OF RUGBY (U.S. CLS. 22, 23, 38 AND 50).

CLASS 41—EDUCATION AND ENTERTAINMENT

FOR EDUCATION AND ENTERTAINMENT SERVICES IN THE NATURE OF ORGANIZING AND CONDUCTING PROFESSIONAL RUGBY GAMES AND EXHIBITIONS; PROVIDING SPORTS AND ENTERTAINMENT INFORMATION VIA A GLOBAL COMPUTER NETWORK OR A COMMERCIAL ON-LINE COMPUTER SERVICE OR BY CABLE, SATELLITE, TELEVISION AND RADIO; ARRANGING AND CONDUCTING ATHLETIC COMPETITIONS, NAMELY, PROFESSIONAL RUGBY GAMES AND EXHIBITIONS; RUGBY FAN CLUB SERVICES; ENTERTAINMENT SERVICES, NAMELY, LIVE MUSICAL AND DANCE PERFORMANCES PROVIDED DURING INTERVALS AT SPORTS EVENTS; EDUCATIONAL SERVICES, NAMELY, PHYSICAL EDUCATION PROGRAMS; PRODUCTION OF RADIO AND TELEVISION PROGRAMS; ENTERTAINMENT SERVICES, NAMELY, PERSONAL APPEARANCES BY A PROFESSIONAL RUGBY PLAYER PROMOTING INTEREST IN RUGBY (U.S. CLS. 100, 101 AND 107).

EMILY CHUO, EXAMINING ATTORNEY

CLASS 44—MEDICAL, BEAUTY AND AGRICULTURAL SERVICES

FOR PROVIDING PHARMACEUTICAL ADVICE AND ADVICE AND INFORMATION REGARDING THE TREATMENT OF HEALTH ISSUES; PROVIDING A WEBSITE FEATURING PHARMACEUTICAL ADVICE AND ADVICE AND INFORMATION REGARDING THE TREATMENT OF HEALTH ISSUES; PROVIDING A WEBSITE FEATURING MEDICAL INFORMATION; PHARMACEUTICAL ADVICE; MEDICAL INFORMATION; PROVIDING NEWS AND INFORMATION IN THE FIELD OF MEDICINE; PROVIDING INFORMATION RELATING TO DIAGNOSTIC, PROPHYLACTIC AND THERAPEUTIC PROPERTIES OF PHARMACEUTICALS; PROVIDING A WEBSITE FEATURING INFORMATION RELATING TO DIAGNOSTIC, PROPHYLACTIC AND THERAPEUTIC PROPERTIES OF PHARMACEUTICALS (U.S. CLS. 100 AND 101).

AMY KERTGATE, EXAMINING ATTORNEY

SN 85-308,225. HARRY BARKER, CHARLESTON, SC. FILED 4-29-2011.

Harry Barker

SN 85-308,173. BIOVAIL LABORATORIES INTERNATIONAL (BARBADOS) SRL, CHRIST CHURCH, BARBADOS, FILED 4-29-2011.



THE COLOR(S) GREEN, YELLOW, PINK, RED, PURPLE AND BLUE IS/ARE CLAIMED AS A FEATURE OF THE MARK.

THE MARK CONSISTS OF A STYLIZED WINDMILL HAVING SIX BLADES, ONE GREEN, ONE YELLOW, ONE PINK, ONE RED, ONE PURPLE AND ONE BLUE.

CLASS 5—PHARMACEUTICALS

FOR PHARMACEUTICAL PREPARATIONS FOR THE TREATMENT OF HUNTINGTON'S DISEASE; PHARMACEUTICAL PREPARATIONS FOR THE TREATMENT OF CHOREA; PHARMACEUTICAL PREPARATIONS FOR THE TREATMENT OF NEUROLOGICAL DISORDERS AND MOVEMENT DISORDERS (U.S. CLS. 6, 18, 44, 46, 51 AND 52).

THE MARK CONSISTS OF STANDARD CHARACTERS WITHOUT CLAIM TO ANY PARTICULAR FONT, STYLE, SIZE, OR COLOR.

OWNER OF U.S. REG. NO. 2,424,818.

THE NAME "HARRY BARKER" DOES NOT IDENTIFY A LIVING INDIVIDUAL.

CLASS 3—COSMETICS AND CLEANING PREPARATIONS

FOR PET CARE KITS COMPRISING SHAMPOO, CONDITIONER, BODY SPRAY; PET FRAGRANCES; PET ODOR REMOVERS; PET SHAMPOO; PET SHAMPOO AND CONDITIONER (U.S. CLS. 1, 4, 6, 50, 51 AND 52).

FIRST USE 0-0-2005; IN COMMERCE 0-0-2005.

CLASS 18—LEATHER GOODS

FOR ALL-PURPOSE CARRYING BAGS; ANIMAL CARRIERS; ANIMAL HARNESES; ANIMAL LEASHES; BEACH BAGS; CLOTHING FOR DOMESTIC PETS; COLLARS FOR PETS; DOG APPAREL; DOG COLLARS; DOG COLLARS AND LEADS; DOG LEASHES; PET ACCESSORIES, NAMELY, SPECIALLY DESIGNED CANVAS, VINYL OR LEATHER BAGS ATTACHED TO ANIMAL LEASHES FOR HOLDING SMALL ITEMS SUCH AS KEYS, CREDIT CARDS, MONEY OR DISPOSABLE BAGS FOR DISPOSING OF PET WASTE; PET CLOTHING; PET COLLAR ACCESSORIES, NAMELY, BOWS AND CHARMS; PET TAGS SPECIALLY ADAPTED FOR ATTACHING TO PET LEASHES OR COLLARS (U.S. CLS. 1, 2, 3, 22 AND 41).

FIRST USE 0-0-2000; IN COMMERCE 0-0-2000.

CLASS 20—FURNITURE AND ARTICLES NOT OTHERWISE CLASSIFIED

FOR DOG BEDS; PET CUSHIONS (U.S. CLS. 2, 13, 22, 25, 32 AND 50).

FIRST USE 0-0-2000; IN COMMERCE 0-0-2000.

CLASS 21—HOUSEWARES AND GLASS

FOR PET BRUSHES; PET FEEDING AND DRINKING BOWLS; PET TREAT JARS; PET WASTE MANAGEMENT KITS COMPRISING SCOOPS FOR PET WASTE DISPOSAL, PLASTIC BAGS AND LINERS, AND PORTABLE DISPENSERS FOR PLASTIC BAGS AND LINERS SOLD AS A UNIT (U.S. CLS. 2, 13, 23, 29, 30, 33, 40 AND 50).
FIRST USE 0-0-2000; IN COMMERCE 0-0-2000.

CLASS 24—FABRICS

FOR PET BLANKETS (U.S. CLS. 42 AND 50).
FIRST USE 0-0-2000; IN COMMERCE 0-0-2000.

CLASS 25—CLOTHING

FOR BATHROBES; HATS; JACKETS; SHIRTS AND SHORT-SLEEVED SHIRTS (U.S. CLS. 22 AND 39).
FIRST USE 0-0-2000; IN COMMERCE 0-0-2000.

CLASS 28—TOYS AND SPORTING GOODS

FOR PET TOYS (U.S. CLS. 22, 23, 38 AND 50).
FIRST USE 0-0-2000; IN COMMERCE 0-0-2000.

CLASS 31—NATURAL AGRICULTURAL PRODUCTS

FOR PET TREATS (U.S. CLS. 1 AND 46).
FIRST USE 0-0-2000; IN COMMERCE 0-0-2000.
ALLISON SCHRODY, EXAMINING ATTORNEY

SN 85-309,230. FLEXIONE A/S, 6650 BRØRUP, DENMARK,
FILED 4-30-2011.

AHCON

THE MARK CONSISTS OF STANDARD CHARACTERS WITHOUT CLAIM TO ANY PARTICULAR FONT, STYLE, SIZE, OR COLOR.

PRIORITY CLAIMED UNDER SEC. 44(D) ON DENMARK APPLICATION NO. VA201100939, FILED 3-29-2011, REG. NO. VR201101761, DATED 7-19-2011, EXPIRES 7-19-2021.

CLASS 7—MACHINERY

FOR MACHINES AND APPARATUS FOR USE IN REPAIRING, CHANGING, TRANSPORTING AND LIFTING TIRES, RIMS AND WHEELS, NAMELY, MECHANICAL AND HYDRAULIC LIFTS, ELEVATORS, HOISTS AND HYDRAULIC LIFT TABLES; HYDRAULIC AND PNEUMATIC MACHINES AND APPARATUS FOR REPAIRING, CHANGING, TRANSPORTING AND LIFTING TIRES, RIMS AND WHEELS, NAMELY, TIRE INFLATION MACHINES, TIRE MOUNTING MACHINES AND WHEEL CONVEYERS; HYDRAULIC CONTROLS FOR MACHINES AND MOTORS; AUTOMATED SUPPLY TABLES IN THE NATURE OF CONVEYOR LINES FOR HANDLING TIRES, RIMS AND WHEELS; BELT CONVEYORS; PUMPS FOR MACHINES; POWERED RAMPS FOR LOADING; COMPRESSED AIR PUMPS; ROLLER BEARINGS FOR MACHINES; MACHINE TABLES, NAMELY, TABLES SPECIALLY ADAPTED TO HOLD POWERED MACHINERY; TIRE SPREADERS AND POWER-OPERATED TIRE SPREADER LIFTS, HYDRAULIC TIRE BEAD BREAKERS; PUMPING STATIONS, NAMELY, AIR PUMPS AS PARTS OF MACHINES, MOTORS AND ENGINES; BLOWING MACHINES FOR THE COMPRESSION, FILLING, EXHAUSTION AND TRANSPORT OF GASES, NAMELY, AIR COMPRESSORS; CAR LIFTS; RUBBER FORMING MACHINES, NAMELY, VULCANIZATION MACHINE FOR REPAIR OF TIRES FOR LAND VEHICLES; VALVES BEING PART OF MACHINES; AIR COMPRESSORS FOR PUMPING TIRES (U.S. CLS. 13, 19, 21, 23, 31, 34 AND 35).

CLASS 9—ELECTRICAL AND SCIENTIFIC APPARATUS

FOR DATA PROCESSING EQUIPMENT AND COMPUTERS; FIRE-EXTINGUISHING APPARATUS; ELECTRIC BATTERIES FOR VEHICLES; CLOTHING FOR PROTECTION AGAINST ACCIDENTS, IRRADIATION AND FIRE; PROTECTION DEVICES FOR PERSONAL USE AGAINST ACCIDENTS, NAMELY, BODY PROTECTION SHIELDS AND SAFETY CAGES FOR WHEEL INFLATION; ELEVATOR OPERATING APPARATUS, NAMELY, ELECTRONIC CONTROLLER TO MANAGE THE POWER, MOVEMENT AND FUNCTIONS OF AN ELEVATOR; REMOTE CONTROLS FOR MECHANICAL AND HYDRAULIC LIFTS, TIRE INFLATION MACHINES AND CONVEYOR LINES; ELECTRIC INSTALLATIONS FOR THE REMOTE CONTROL OF INDUSTRIAL OPERATIONS; ELECTRICAL DISTRIBUTION BOXES AND CONNECTORS; SPEED INDICATORS; SLOPE INDICATORS; ELECTRIC CABLES AND ELECTRICITY CONDUITS; SHEATHS FOR ELECTRIC CABLES; ELECTRICAL POWER DISTRIBUTION BOARDS; ELECTRIC REGULATING APPARATUS, NAMELY, VOLTAGE REGULATORS FOR ELECTRIC POWER; COMPUTER MONITORS; ELECTRIC INVERTERS AND CONVERTERS; SAFETY TARPAULINS; CIRCUIT BREAKERS; PRESSURE GAUGES; COUNTERS FOR MEASURING THE NUMBER OF TIRE REVOLUTIONS; BALANCING APPARATUS, NAMELY, TIRE BALANCING MACHINES FOR LAND VEHICLES; MEASURING APPARATUS AND INSTRUMENTS, NAMELY, LASER DISTANCE METERS AND TIRE PRESSURE MEASURERS; ELECTRIC MEASURING APPARATUS AND INSTRUMENTS, NAMELY, DISTANCE MEASURING APPARATUS AND PRESSURE GAUGES; AUTOMATIC INDICATORS OF PRESSURE IN VEHICLE TIRES; COMPUTER PROGRAMS AND COMPUTER HARDWARE FOR USE IN MEASURING PRESSURE IN TIRES AND MEASURING BALANCE IN RIMS AND WHEELS (U.S. CLS. 21, 23, 26, 36 AND 38).

CLASS 12—VEHICLES

FOR VEHICLES, NAMELY, LAND VEHICLES; APPARATUS FOR LOCOMOTION BY LAND, NAMELY, MOTORIZED OR NON-MOTORIZED MOBILE CARTS AND TROLLEYS FOR TRANSPORTING AND MOVING TIRES, RIMS AND WHEELS; ELECTRIC LAND VEHICLES, NAMELY, MOBILE CARTS FOR TRANSPORTING AND MOVING TIRES, RIMS AND WHEELS; LIFTING TRUCKS, NAMELY, FORK LIFT TRUCKS; BALANCING WEIGHTS AND BLOCKS FOR RIMS AND WHEELS ON VEHICLES; TIRES, WHEEL RIMS AND WHEELS FOR VEHICLES; LUGGAGE CARRIERS FOR VEHICLES; TREADS FOR RETREADING VEHICLE TIRES; TRANS-

MISSION CHAINS FOR LAND VEHICLES; JET ENGINES FOR LAND VEHICLES; CABLE TRANSPORT APPARATUS AND INSTALLATIONS, NAMELY, CABLE CARS; THREE OR FOUR WHEELED MINI CARS; MINI TRANSPORT WAGONS; WHEELS FOR THREE OR FOUR WHEELED MINI CARS AND FOR MINI TRANSPORT CARTS; VEHICLE ACCESSORIES, NAMELY, AIR PUMPS FOR AUTOMOBILES; VEHICLE WHEEL TIRES; TWO-WHEELED TROLLEYS; TILTING CARTS; TROLLEYS; WHEELING DEVICES IN THE NATURE OF DOLLIES, CARTS AND WHEEL BARROWS FOR TRANSPORTING AND MOVING TIRES, RIMS AND WHEELS; PARTS AND FITTINGS FOR ALL THE AFORESAID GOODS, NOT INCLUDED IN OTHER CLASSES, NAMELY, TIRE INFLATORS AND TIRE PUMPS (U.S. CLS. 19, 21, 23, 31, 35 AND 44).

B. PARADEWELAI, EXAMINING ATTORNEY

SN 85-309,637. WEST CORPORATION, OMAHA, NE. FILED 5-2-2011.

THOR SHIELD

THE MARK CONSISTS OF STANDARD CHARACTERS WITHOUT CLAIM TO ANY PARTICULAR FONT, STYLE, SIZE, OR COLOR.

OWNER OF U.S. REG. NO. 3,571,519.

CLASS 35—ADVERTISING AND BUSINESS

FOR OPERATION AND MANAGEMENT OF TELEPHONE CALL CENTERS FOR OTHERS; LOGISTICS MANAGEMENT IN THE FIELD OF 911 EMERGENCY SERVICES (U.S. CLS. 100, 101 AND 102).

CLASS 45—PERSONAL AND LEGAL SERVICES

FOR MONITORING TELEPHONE CALLS FROM SUBSCRIBERS AND NOTIFYING EMERGENCY FACILITIES; PROVIDING CONSULTATION AND INFORMATION IN THE FIELD OF EMERGENCY RESPONSE FOR COMMUNITIES; EMERGENCY RESPONSE ALARM MONITORING SERVICES, NAMELY, MONITORING OF ALERT DEVICES BY A REMOTE MONITORING CENTER FOR THE DISPATCH OF EMERGENCY PUBLIC HEALTH AND SECURITY SERVICES AND NOTIFICATION TO THIRD PARTIES (U.S. CLS. 100 AND 101).

CHRISIE B. KING, EXAMINING ATTORNEY

SN 85-310,599. IFBYPHONE, INC., SKOKIE, IL. FILED 5-3-2011.

SOURCETRAK

THE MARK CONSISTS OF STANDARD CHARACTERS WITHOUT CLAIM TO ANY PARTICULAR FONT, STYLE, SIZE, OR COLOR.

CLASS 35—ADVERTISING AND BUSINESS

FOR BUSINESS MARKETING SERVICES FOR OTHERS, NAMELY, TRACKING AND MONITORING CALLS IN RESPONSE TO ADVERTISING AND MARKETING; MEASURING EFFECTIVENESS OF ADVERTISING AND MARKETING CAMPAIGNS BY ANALYZING ADVERTISING RESPONSES (U.S. CLS. 100, 101 AND 102).

FIRST USE 8-0-2010; IN COMMERCE 9-1-2010.

CLASS 38—COMMUNICATION

FOR TELECOMMUNICATIONS SERVICES, NAMELY, AUTOMATIC ROUTING OF CALLS TO THIRD PARTIES BASED ON MARKETING RESPONSES (U.S. CLS. 100, 101 AND 104).

FIRST USE 8-0-2010; IN COMMERCE 9-1-2010.

SUSAN LESLIE DUBOIS, EXAMINING ATTORNEY

SN 85-310,824. CHICAGO MERCANTILE EXCHANGE INC., CHICAGO, IL. FILED 5-3-2011.

CME POSITION INTELLIGENCE

THE MARK CONSISTS OF STANDARD CHARACTERS WITHOUT CLAIM TO ANY PARTICULAR FONT, STYLE, SIZE, OR COLOR.

OWNER OF U.S. REG. NOS. 2,973,035, 3,367,684 AND OTHERS.

CLASS 9—ELECTRICAL AND SCIENTIFIC APPARATUS

FOR COMPUTER SOFTWARE FOR USE IN TRADING, CLEARING, CONFIRMATION, AND FINANCIAL TRADING RISK MANAGEMENT FOR EXCHANGE MARKET TRANSACTIONS IN THE FIELD OF FUTURES, OPTIONS, SWAPS, AND OTHER DERIVATIVE CONTRACTS (U.S. CLS. 21, 23, 26, 36 AND 38).

CLASS 36—INSURANCE AND FINANCIAL

FOR PROVIDING EXCHANGE MARKETS FOR TRADING, CLEARING, CONFIRMATION AND FINANCIAL TRADING RISK MANAGEMENT IN THE FIELD OF FUTURES, OPTIONS, SWAPS, AND OTHER DERIVATIVE CONTRACTS (U.S. CLS. 100, 101 AND 102).

CLASS 42—SCIENTIFIC AND COMPUTER SERVICES

FOR PROVIDING TEMPORARY ON-LINE USE OF NON-DOWNLOADABLE SOFTWARE FOR TRADING, CLEARING, CONFIRMATION, AND FINANCIAL TRADING RISK MANAGEMENT FOR EXCHANGE MARKET TRANSACTIONS IN THE FIELD OF FUTURES, OPTIONS, SWAPS, AND OTHER DERIVATIVE CONTRACTS (U.S. CLS. 100 AND 101).

WILLIAM P. SHANAHAN, EXAMINING ATTORNEY

SN 85-310,978. IQOR TECHNOLOGIES, INC., NEW YORK, NY. FILED 5-3-2011.

SN 85-311,124. DESCHAMPS, PHILIPPE, PARIS, FRANCE, FILED 5-3-2011.

QORCO

THE MARK CONSISTS OF STANDARD CHARACTERS WITHOUT CLAIM TO ANY PARTICULAR FONT, STYLE, SIZE, OR COLOR.

CLASS 35—ADVERTISING AND BUSINESS

FOR ACCOUNTS RECEIVABLE SERVICES AND MANAGEMENT; OPERATION OF CALL CENTERS FOR OTHERS (U.S. CLS. 100, 101 AND 102).

CLASS 36—INSURANCE AND FINANCIAL

FOR DEBT COLLECTION SERVICES AND MANAGEMENT; FINANCIAL DEBT COLLECTIONS (U.S. CLS. 100, 101 AND 102).

KATHLEEN LORENZO, EXAMINING ATTORNEY

SN 85-310,982. IQOR TECHNOLOGIES, INC., NEW YORK, NY. FILED 5-3-2011.

QFIT

THE MARK CONSISTS OF STANDARD CHARACTERS WITHOUT CLAIM TO ANY PARTICULAR FONT, STYLE, SIZE, OR COLOR.

CLASS 35—ADVERTISING AND BUSINESS

FOR PROVIDING ONLINE EMPLOYMENT INFORMATION AND SERVICES IN THE FIELDS OF PSYCHOLOGICAL TESTING FOR THE SELECTION OF PERSONNEL (U.S. CLS. 100, 101 AND 102).

CLASS 42—SCIENTIFIC AND COMPUTER SERVICES

FOR COMPUTER SOFTWARE AND APPLICATION SERVICES PROVIDER, NAMELY, HOSTING, MANAGING, DEVELOPING, ANALYZING AND MAINTAINING APPLICATIONS, SOFTWARE AND WEB SITES FOR OTHERS THAT CONDUCT ONLINE PERSONAL LIFESTYLE PERFORMANCE ASSESSMENTS AND PROVIDE SKILL ENHANCEMENT PROGRAMS BASED ON SELECTED PRINCIPLES OF EMOTIONAL INTELLIGENCE AND TRACK PERFORMANCE, REWARDS AND INCENTIVE PROGRAMS IN THE FIELD OF EMPLOYMENT AND EMPLOYEE PERFORMANCE (U.S. CLS. 100 AND 101).

KATHLEEN LORENZO, EXAMINING ATTORNEY

SLAM JACK

THE MARK CONSISTS OF STANDARD CHARACTERS WITHOUT CLAIM TO ANY PARTICULAR FONT, STYLE, SIZE, OR COLOR.

CLASS 18—LEATHER GOODS

FOR LUGGAGE, NAMELY, TRAVEL BAGS, HANDBAGS, SCHOOL BAGS, SPORT BAGS, SUITCASES, BACKPACKS, WAIST PACKS, HUNTERS' GAME BAGS, KEY CASES, POCKET WALLETS, PURSES, AND UMBRELLAS (U.S. CLS. 1, 2, 3, 22 AND 41).

CLASS 25—CLOTHING

FOR CLOTHING, NAMELY, TEE-SHIRTS, SWEAT SHIRTS, SHIRTS, SLEEVELESS TOPS, PANTS, TROUSERS, JERSEYS, SHORTS, JACKETS, COATS, UNDERWEAR; GLOVES, CAPS, BELTS; FOOTWEAR (U.S. CLS. 22 AND 39).

CLASS 28—TOYS AND SPORTING GOODS

FOR TOYS AND GAMES, NAMELY, FIGURINES, DOLLS, FIGURES, CARTOON FIGURES; MODELS, NAMELY, MODEL VEHICLES, MODEL TRAINS, MODEL BOATS, AND MODEL AIRCRAFT; SPORT APPARATUS, NAMELY, PAINTBALL GUNS AND PAINTBALLS, TOY AIR PISTOLS, TARGETS, GLOVES FOR PAINTBALL, HOCKEY, AND BATTING; EXTREME SPORTS GOODS, NAMELY, SURF BOARDS, SAIL BOARDS, SKATEBOARDS, SNOWBOARDS, SKIS, WATER SKIS, SNOW SHOES, PROTECTIVE PADDING FOR PLAYING EXTREME SPORTS, NAMELY, SKATEBOARDING, SNOWBOARDING, PAINTBALLING, AND SKIING; RACKETS (U.S. CLS. 22, 23, 38 AND 50).

DAVID COLLIER, EXAMINING ATTORNEY

SN 85-312,525. WRIGHT EXPRESS CORPORATION, SOUTH PORTLAND, ME. FILED 5-4-2011.

WEXSMART

THE MARK CONSISTS OF STANDARD CHARACTERS WITHOUT CLAIM TO ANY PARTICULAR FONT, STYLE, SIZE, OR COLOR.

OWNER OF U.S. REG. NOS. 1,947,273, 2,218,706 AND 2,374,743.

CLASS 35—ADVERTISING AND BUSINESS

FOR TRACKING, LOCATING, AND MONITORING OF VEHICLES FOR COMMERCIAL PURPOSES (U.S. CLS. 100, 101 AND 102).

FIRST USE 5-1-2007; IN COMMERCE 5-1-2007.

CLASS 36—INSURANCE AND FINANCIAL

FOR COMMERCIAL FLEET CREDIT CARD SERVICES (U.S. CLS. 100, 101 AND 102).

FIRST USE 5-1-2007; IN COMMERCE 5-1-2007.

CLASS 37—CONSTRUCTION AND REPAIR

FOR VEHICLE MAINTENANCE AND CONSULTATION SERVICES, NAMELY, RECORD KEEPING OF VEHICLE MAINTENANCE USE, SAFETY, AND PERFORMANCE VIA A GLOBAL COMPUTER NETWORK; PROVIDING INFORMATION IN THE FIELDS OF SCHEDULED AUTOMOTIVE MAINTENANCE APPOINTMENTS AND AUTOMOTIVE MAINTENANCE NOTIFICATION; VEHICLE MAINTENANCE SERVICES, NAMELY, VEHICLE EMISSIONS MONITORING AND VEHICLE PERFORMANCE MONITORING VIA A GLOBAL INFORMATION NETWORK (U.S. CLS. 100, 103 AND 106).

FIRST USE 5-1-2007; IN COMMERCE 5-1-2007.

CLASS 42—SCIENTIFIC AND COMPUTER SERVICES

FOR AUTOMOTIVE DIAGNOSTIC SERVICES FEATURING COMPUTER SOFTWARE FOR USE BY INDEPENDENT AUTOMOTIVE REPAIR PERSONNEL VIA A GLOBAL COMPUTER NETWORK (U.S. CLS. 100 AND 101).

FIRST USE 5-1-2007; IN COMMERCE 5-1-2007.

CLASS 45—PERSONAL AND LEGAL SERVICES

FOR STOLEN VEHICLE RECOVERY SERVICES; FRAUD DETECTION AND PREVENTION SERVICES (U.S. CLS. 100 AND 101).

FIRST USE 5-1-2007; IN COMMERCE 5-1-2007.

KAPIL BHANOT, EXAMINING ATTORNEY

SN 85-313,542. IDL BIOTECH AB, BROMMA, SWEDEN, FILED 5-5-2011.

UBA

THE MARK CONSISTS OF STANDARD CHARACTERS WITHOUT CLAIM TO ANY PARTICULAR FONT, STYLE, SIZE, OR COLOR.

CLASS 1—CHEMICALS

FOR IN VITRO LABORATORY CHEMICAL TEST KITS FOR DETECTION OF URINARY BLADDER CANCER FOR LABORATORY USE; DIAGNOSTIC TEST KITS CONSISTING PRIMARILY OF DIAGNOSTIC PREPARATIONS FOR MEDICAL LABORATORY USE; CHEMICAL SUBSTANCES FOR NON-MEDICAL PURPOSES, NAMELY, FOR USE IN MEDICAL LABORATORY TESTING IN CONNECTION WITH URINARY BLADDER CANCER (U.S. CLS. 1, 5, 6, 10, 26 AND 46).

CLASS 5—PHARMACEUTICALS

FOR CHEMICAL REAGENTS FOR MEDICAL PURPOSES IN CONNECTION WITH URINARY BLADDER CANCER (U.S. CLS. 6, 18, 44, 46, 51 AND 52).

JILL C. ALT, EXAMINING ATTORNEY

SN 85-314,110. HONG KONG CITY TOYS FACTORY LIMITED, KOWLOON, HONG KONG, FILED 5-6-2011.

KIDS LE MONDE

THE MARK CONSISTS OF STANDARD CHARACTERS WITHOUT CLAIM TO ANY PARTICULAR FONT, STYLE, SIZE, OR COLOR.

NO CLAIM IS MADE TO THE EXCLUSIVE RIGHT TO USE "KIDS", APART FROM THE MARK AS SHOWN.

THE ENGLISH TRANSLATION OF "LE MONDE" IN THE MARK IS "THE WORLD".

CLASS 18—LEATHER GOODS

FOR PET PRODUCTS, NAMELY, CLOTHING FOR DOMESTIC PETS; COLLARS FOR DOMESTIC PETS; PET COLLAR ACCESSORIES, NAMELY, BOWS AND CHARMS; PET TAGS SPECIALLY ADAPTED FOR ATTACHING TO PET LEASHES OR COLLARS; PET HAIR ORNAMENTS; PET PRODUCTS IN THE NATURE OF A RESTRAINING DEVICE, NAMELY, TIE-OUT STAKES AND TIE-OUT CHAINS; PET PRODUCTS, NAMELY, PET RESTRAINING DEVICES CONSISTING OF LEASHES, COLLARS, HARNESSSES, MUZZLES, RESTRAINING STRAPS, AND LEASHES WITH LOCKING DEVICES; PET COLLAR ACCESSORIES, NAMELY, CHARMS (U.S. CLS. 1, 2, 3, 22 AND 41).

CLASS 25—CLOTHING

FOR JEANS, T-SHIRTS, SWEATERS, COATS, JACKETS, HOODED SWEATSHIRTS, SWEATSHIRTS, PANTS, SHOES, SOCKS, HATS, CAPS, AND SCARVES (U.S. CLS. 22 AND 39).

CLASS 28—TOYS AND SPORTING GOODS

FOR DOLLS, DOLL CLOTHING, DOLL ACCESSORIES, STUFFED DOLLS, PLASTIC DOLLS, STUFFED ANIMALS, PRESCHOOL TOYS (U.S. CLS. 22, 23, 38 AND 50).

JILL C. ALT, EXAMINING ATTORNEY

SN 85-315,309. JOHNSON & JOHNSON, NEW BRUNSWICK, NJ. FILED 5-9-2011.

LISTERINE RAPID CLEAN

THE MARK CONSISTS OF STANDARD CHARACTERS WITHOUT CLAIM TO ANY PARTICULAR FONT, STYLE, SIZE, OR COLOR.

OWNER OF U.S. REG. NOS. 118,052, 3,218,074 AND OTHERS.

NO CLAIM IS MADE TO THE EXCLUSIVE RIGHT TO USE "CLEAN", APART FROM THE MARK AS SHOWN.

CLASS 3—COSMETICS AND CLEANING PREPARATIONS

FOR NON-MEDICATED MOUTH RINSE; BREATH FRESHENER; DENTIFRICE (U.S. CLS. 1, 4, 6, 50, 51 AND 52).

CLASS 5—PHARMACEUTICALS

FOR MEDICATED MOUTH RINSE; MEDICATED BREATH FRESHENERS WITH FLUORIDE; MEDICATED DENTIFRICE WITH FLUORIDE (U.S. CLS. 6, 18, 44, 46, 51 AND 52).

LAURIE MAYES, EXAMINING ATTORNEY

SN 85-315,374. MICHAEL HOWARD, PARENT/LEGAL GUARDIAN OF CASSANDRA COLETTE HOWARD, NORTHPORT, NY. FILED 5-9-2011.



THAT PUP

THE MARK CONSISTS OF A STYLIZED DRAWING OF A DOG WITH THE WORDS "THAT PUP" BELOW THE STYLIZED DRAWING.

CLASS 9—ELECTRICAL AND SCIENTIFIC APPARATUS

FOR DECORATIVE MAGNETS (U.S. CLS. 21, 23, 26, 36 AND 38).

CLASS 16—PAPER GOODS AND PRINTED MATTER

FOR STICKERS (U.S. CLS. 2, 5, 22, 23, 29, 37, 38 AND 50).

CLASS 18—LEATHER GOODS

FOR BACKPACKS (U.S. CLS. 1, 2, 3, 22 AND 41).

CLASS 25—CLOTHING

FOR CLOTHING, NAMELY, SHIRTS AND HATS (U.S. CLS. 22 AND 39).

ANN E. SAPPENFIELD, EXAMINING ATTORNEY

SN 85-315,441. AMY GURVEY, UPPER MONTCLAIR, NJ. FILED 5-9-2011.

STICKETS

THE MARK CONSISTS OF STANDARD CHARACTERS WITHOUT CLAIM TO ANY PARTICULAR FONT, STYLE, SIZE, OR COLOR.

CLASS 9—ELECTRICAL AND SCIENTIFIC APPARATUS

FOR COMPUTER SOFTWARE AND HARDWARE FOR USE IN THE LIVE EVENT CONTENT DISTRIBUTION CYCLE BY: PRODUCERS/PROMOTERS/HOSTING VENUES, BROADCASTERS/ISPs/TRANSMITTERS, GLOBAL BRAND SPONSORS/ADVERTISERS, AND END-USER CONSUMERS, TO ENABLE END-TO-END MANAGEMENT OF EVENTS AND BROADCASTS INCLUDING SYSTEMS THAT ENABLE EVENT INTERACTION AND CONTENT TRANSMISSIONS IN CLOSE TO REAL TIME (U.S. CLS. 21, 23, 26, 36 AND 38).

CLASS 35—ADVERTISING AND BUSINESS

FOR AD SERVING, NAMELY, PLACING ADVERTISEMENTS ON WEBSITES FOR OTHERS USING SPECIALIZED COMPUTER SOFTWARE; ADVERTISING, PROMOTION, AND MARKETING SERVICES IN THE NATURE OF PLACING LOGOS, ICONS, SPONSOR MESSAGES AND/OR ADVERTISEMENTS ON ELECTRONIC INTERFACES, TICKETING INTERFACES, SCREENS, SUB-SCREENS AND WEBSITES FOR OTHERS TO ACCESS USING SPECIALIZED COMPUTER SOFTWARE (U.S. CLS. 100, 101 AND 102).

PAM WILLIS, EXAMINING ATTORNEY

SN 85-315,539. NYCO PRODUCTS CO., COUNTRYSIDE, IL. FILED 5-9-2011.



NO CLAIM IS MADE TO THE EXCLUSIVE RIGHT TO USE "PORTABLE DISPENSING SYSTEM", APART FROM THE MARK AS SHOWN.

THE MARK CONSISTS OF THE WORD MARK "EZ2MIX" APPEARS ABOVE THE WORDS "PORTABLE DISPENSING SYSTEM", WHICH IS POSITIONED OVER A BAR. THE DOT IN THE "I" IN "MIX" IS IN THE FORM OF A DROP OF LIQUID.

CLASS 1—CHEMICALS

FOR CHEMICAL PREPARATIONS FOR CLEANING PURPOSES FOR INDUSTRIAL USE; DEGREASING SOLUTIONS FOR INDUSTRIAL USE ON FLOORS, WALLS, EQUIPMENT, AND OTHER SURFACES (U.S. CLS. 1, 5, 6, 10, 26 AND 46).

FIRST USE 1-5-2011; IN COMMERCE 1-5-2011.

CLASS 21—HOUSEWARES AND GLASS

FOR DISPENSERS INCORPORATING DILUTION UNITS FOR MIXING WATER WITH CLEANING PREPARATIONS AND DEGREASING SOLUTIONS (U.S. CLS. 2, 13, 23, 29, 30, 33, 40 AND 50).

FIRST USE 1-5-2011; IN COMMERCE 1-5-2011.

REBECCA EISINGER, EXAMINING ATTORNEY

SN 85-315,652. HRBA GROUP, INC., MARBLEHEAD, MA.
FILED 5-9-2011.

ProSential

THE MARK CONSISTS OF THE WORD "PROSENTIAL" WITH A STYLIZED DIRECTIONAL ARROW DESIGN OVER THE LETTER "I".

CLASS 35—ADVERTISING AND BUSINESS

FOR PAYROLL ADMINISTRATION AND MANAGEMENT SERVICES; ADMINISTRATION OF BUSINESS PAYROLL FOR OTHERS; HUMAN RESOURCES MANAGEMENT AND CONSULTATION (U.S. CLS. 100, 101 AND 102).

CLASS 36—INSURANCE AND FINANCIAL

FOR PROCESSING, ADMINISTERING AND MANAGING EMPLOYEE BENEFIT PLANS CONCERNING INSURANCE AND FINANCE (U.S. CLS. 100, 101 AND 102).

LINDA E. BLOHM, EXAMINING ATTORNEY

SN 85-316,958. DAVID S. HYATT, WEST HARTFORD, CT.
FILED 5-10-2011.

YAADPRIDE

THE MARK CONSISTS OF STANDARD CHARACTERS WITHOUT CLAIM TO ANY PARTICULAR FONT, STYLE, SIZE, OR COLOR.

CLASS 25—CLOTHING

FOR CLOTHING, NAMELY, SHIRTS, SWEATSHIRTS, SWEAT JACKETS, JACKETS, UNDERGARMENTS, SLEEPWEAR, HATS, AND WRIST AND HEADBANDS (U.S. CLS. 22 AND 39).

CLASS 35—ADVERTISING AND BUSINESS

FOR ON-LINE RETAIL STORE SERVICES FEATURING CLOTHING (U.S. CLS. 100, 101 AND 102).
SUNG IN, EXAMINING ATTORNEY

SN 85-317,714. REPUBLIC OF KOREA (NATIONAL FISHERIES RESEARCH AND DEVELOPMENT INSTITUTE), BUSAN, REPUBLIC OF KOREA, FILED 5-11-2011.

Halibut
KingNupchi

NO CLAIM IS MADE TO THE EXCLUSIVE RIGHT TO USE "HALIBUT", APART FROM THE MARK AS SHOWN.

THE NAME "KING NUPCHI" DOES NOT IDENTIFY A LIVING INDIVIDUAL.

THE MARK CONSISTS OF THE WORDS "HALIBUT KINGNUPCHI".

CLASS 29—MEATS AND PROCESSED FOODS

FOR FISH, NAMELY, HALIBUT (U.S. CL. 46).

CLASS 31—NATURAL AGRICULTURAL PRODUCTS

FOR LIVE FISH, NAMELY, HALIBUT (U.S. CLS. 1 AND 46).

SHAUNIA CARLYLE, EXAMINING ATTORNEY

SN 85-317,726. DIMEXON INTERNATIONAL HOLDING B.V., UTRECHT, NETHERLANDS, FILED 5-11-2011.

DIMEXON.

PRIORITY CLAIMED UNDER SEC. 44(D) ON ERPNCMNTY TM OFC APPLICATION NO. 009923426, FILED 4-27-2011.

THE COLOR(S) GREY AND ROSE IS/ARE CLAIMED AS A FEATURE OF THE MARK.

THE MARK CONSISTS OF THE TEXT "DIMEXON" IN THE COLOR GREY IN A STYLIZED FORMAT FOLLOWED BY A PUNCTUATION PERIOD IN THE COLOR ROSE.

CLASS 14—JEWELRY

FOR PRECIOUS METALS AND THEIR ALLOYS AND GOODS IN PRECIOUS METALS OR COATED THEREWITH, NOT INCLUDED IN OTHER CLASSES, NAMELY, JEWELRY, WORKS OF ART OF PRECIOUS METALS AND BOXES OF PRECIOUS METALS FOR JEWELRY; JEWELLERY, PRECIOUS STONES; HOROLOGICAL AND CHRONOMETRIC INSTRUMENTS (U.S. CLS. 2, 27, 28 AND 50).

CLASS 35—ADVERTISING AND BUSINESS

FOR RETAIL STORE, ON-LINE RETAIL STORE AND MAIL ORDER SERVICES FEATURING PRECIOUS METALS AND THEIR ALLOYS AND GOODS IN PRECIOUS METALS OR COATED THEREWITH, NAMELY, JEWELLERY, WORKS OF ART OF PRECIOUS METALS AND BOXES OF PRECIOUS METALS FOR JEWELRY, PRECIOUS STONES, AND HOROLOGICAL AND CHRONOMETRIC INSTRUMENTS (U.S. CLS. 100, 101 AND 102).
HAI-LY LAM, EXAMINING ATTORNEY

SN 85-317,971. ASIA PACIFIC LAND LIMITED, HONG KONG, HONG KONG, FILED 5-11-2011.

APL

THE MARK CONSISTS OF STANDARD CHARACTERS WITHOUT CLAIM TO ANY PARTICULAR FONT, STYLE, SIZE, OR COLOR.

CLASS 35—ADVERTISING AND BUSINESS

FOR ADVERTISING; MARKETING, NAMELY, PROMOTING OR ADVERTISING THE GOODS AND SERVICES OF OTHERS; COMMERCIAL AND BUSINESS MANAGEMENT; BUSINESS PLANNING AND MANAGEMENT OF BUILDINGS; BUSINESS MANAGEMENT OF REAL ESTATE FOR OTHERS; BUSINESS MANAGEMENT AND BUSINESS ADMINISTRATION; BUSINESS RESEARCH; BUSINESS MANAGEMENT AND BUSINESS ADMINISTRATION FOR BUSINESSES OF REAL ESTATE, RESIDENTIAL, INDUSTRIAL AND COMMERCIAL PROPERTIES, OFFICES, BUSINESS CENTERS, DEPARTMENTAL STORES, SHOPPING CENTERS, RETAIL AND WHOLESALE OUTLETS, TEMPORARY ACCOMMODATION, HOTELS, MOTELS, RESORTS, SERVICE APARTMENTS, BUILDINGS, HOUSES, CONDOMINIUMS, APARTMENTS, FLATS, WAREHOUSES, FACTORIES AND DEVELOPMENTS; ORGANIZATION OF EXHIBITIONS FOR BUSINESS AND COMMERCIAL PURPOSES; BUSINESS MANAGEMENT IN RELATION TO COMMERCIAL PROPERTY; THE BRINGING TOGETHER, FOR THE BENEFIT OF OTHERS, OF A VARIETY OF GOODS, ENABLING CUSTOMERS TO CONVENIENTLY VIEW AND PURCHASE THOSE GOODS IN THE FIELD OF REAL ESTATE; COMPILATION OF MAILING LISTS; DIRECT MAIL ADVERTISING; BUSINESS MERCHANDISING DISPLAY SERVICES; PUBLICITY SERVICES; MARKETING AND PROMOTIONAL SERVICES, MARKET ANALYSIS AND RESEARCH; ORGANIZATION OF BUSINESS COMPETITIONS; PROJECT MANAGEMENT SERVICES FOR OTHERS FOR BUSINESS PURPOSES IN THE FIELD OF REAL ESTATE; TURNKEY RETAIL START-UP SERVICES, NAMELY, COORDINATION AND ASSUMPTION OF RESPONSIBILITY FOR ALL ASPECTS OF THE STORE-OPENING PROCESS OF OTHERS; ADVISORY AND CONSULTANCY SERVICES RELATING TO THE AFORESAID (U.S. CLS. 100, 101 AND 102).

FIRST USE 12-0-1994; IN COMMERCE 12-0-1994.

CLASS 36—INSURANCE AND FINANCIAL

FOR FUND MANAGEMENT; FUND INVESTMENT; INTERNATIONAL FUND INVESTMENT; FINANCIAL SERVICES, NAMELY, INVESTMENT ADVICE, INVESTMENT MANAGEMENT, INVESTMENT CONSULTATION AND INVESTMENT OF FUNDS FOR OTHERS, INCLUDING PRIVATE AND PUBLIC EQUITY AND DEBT INVESTMENT SERVICES; REAL ESTATE FINANCING; REAL ESTATE EQUITY SHARING, NAMELY, MANAGING AND ARRANGING FOR CO-OWNERSHIP OF REAL ESTATE; DEVELOPING AND ORGANIZING SECURITIZATION FINANCIAL STRUCTURES, NAMELY, ADMINISTERING THE ISSUANCE, UNDERWRITING AND DISTRIBUTION OF SECURITIES; FINANCIAL EVALUATION OF REAL ESTATE; CAPITAL INVESTMENT; REAL ESTATE INVESTMENT; ADMINISTRATION OF TRUSTS, NAMELY, INVESTMENT AND TRUST COMPANY SERVICES; CORPORATE TRUSTS SERVICES, NAMELY, INVESTMENT AND TRUST COMPANY SERVICES; FINANCIAL TRUST MANAGEMENT; INVESTMENT TRUST MANAGEMENT; INVESTMENT TRUST SERVICES, NAMELY, INVESTMENT AND TRUST COMPANY SERVICES; PRIVATE CLIENT UNIT INVESTMENT TRUST MANAGEMENT SERVICES; PROPERTY UNIT TRUST, NAMELY, REAL ESTATE INVESTMENT TRUST SERVICES; UNIT INVESTMENT TRUST MANAGEMENT AND UNIT TRUST SERVICES, NAMELY, FINANCIAL TRUST OPERATIONS; REAL ESTATE TRUSTEE SERVICES; ACQUISITION OF REAL

ESTATE; REAL ESTATE MANAGEMENT OF BUILDING DEVELOPMENTS; LEASING OF BUILDINGS; REAL ESTATE MANAGEMENT OF THE BUILDINGS; ENVIRONMENT; ADVISORY AND INFORMATION SERVICES RELATING TO REAL ESTATE BROKERAGE; REAL ESTATE AFFAIRS, NAMELY, RENTAL BROKERAGE, LEASING AND MANAGEMENT OF COMMERCIAL PROPERTY, OFFICES AND OFFICE SPACE; REAL ESTATE AGENCY SERVICES; LETTING AND LEASING OF REAL ESTATE, RESIDENTIAL, INDUSTRIAL AND COMMERCIAL PROPERTIES, OFFICES, BUSINESS CENTERS, DEPARTMENTAL STORES, SHOPPING CENTERS, RETAIL AND WHOLESALE OUTLETS, SERVICE APARTMENTS, BUILDINGS, HOUSES, CONDOMINIUMS, APARTMENTS, FLATS, WAREHOUSES, FACTORIES AND DEVELOPMENTS; REAL ESTATE MANAGEMENT AND VALUATION; FINANCIAL ASSET MANAGEMENT; CAPITAL FUND MANAGEMENT, CORPORATE FUND MANAGEMENT, FINANCIAL FUND MANAGEMENT AND INVESTMENT FUND MANAGEMENT; UNIT INVESTMENT TRUST FUND INVESTMENT SERVICES; FINANCIAL MARKET INFORMATION SERVICES; ORGANIZATION OF STOCK EXCHANGES FOR THE BENEFIT OF THE TRADE OF STOCKS AND OTHER FINANCIAL VALUES; CORPORATE FINANCE, NAMELY, CONSULTATION IN THE FIELD OF ASSET SALES; SECURITIES BROKERAGE; MANAGEMENT OF SECURITIES PORTFOLIOS; FINANCIAL SERVICES, NAMELY, DEALING IN SECURITIES AS A MARKET MAKER AND IN TRADING COMMODITIES, SECURITIES, OPTIONS, FUTURES, EQUITIES AND FIXED INCOME PRODUCTS IN THE U.S. AND OVERSEAS MARKET SECURITIES; TRADING IN SECURITIES; SECURITIES INVESTMENT SERVICES, NAMELY, MANAGEMENT AND BROKERAGE IN THE FIELDS OF STOCKS, BONDS, OPTIONS, COMMODITIES, FUTURES AND OTHER SECURITIES, AND THE INVESTMENT OF FUNDS OF OTHERS; STOCKS AND BONDS BROKERAGE; BUSINESS TRUST SERVICES, NAMELY, FINANCIAL TRUST PLANNING; CORPORATE TRUST MANAGEMENT AND FINANCIAL TRUST MANAGEMENT SERVICES; SURETY SERVICES; TRUSTEESHIP REPRESENTATIVES; TRUST SERVICES, NAMELY, INVESTMENT AND TRUST COMPANY SERVICES; REAL ESTATE INVESTMENT TRUST MANAGEMENT SERVICES; ESTABLISHMENT OF REAL ESTATE INVESTMENT TRUSTS; FINANCIAL ADVISORY, MANAGEMENT AND CONSULTANCY SERVICES; FINANCIAL EVALUATION AND ANALYSIS; FINANCIAL UNDERWRITING, NAMELY, ADMINISTERING THE ISSUANCE, UNDERWRITING AND DISTRIBUTION OF SECURITIES; FINANCING SERVICES; CREDIT SERVICES, NAMELY, CREDIT AGENCIES FEATURING CREDIT PROCESSING, NAMELY, CREDIT CHECKING, CREDIT ANALYZING, AND FINANCIAL REPORTING SERVICES; FINANCIAL GUARANTEE SERVICES; PRIVATE PLACEMENT OF FUNDS AND SECURITIES; ADVISORY AND CONSULTANCY SERVICES RELATING TO THE AFORESAID (U.S. CLS. 100, 101 AND 102).

FIRST USE 12-0-1994; IN COMMERCE 12-0-1994.

CLASS 37—CONSTRUCTION AND REPAIR

FOR REAL ESTATE DEVELOPMENT; LAND DEVELOPMENT SERVICES, NAMELY, PLANNING AND LAYING OUT OF RESIDENTIAL AND/OR COMMERCIAL COMMUNITIES; BUILDING CONSTRUCTION SERVICES; CONSTRUCTION, RENOVATION, REFURBISHMENT, MAINTENANCE AND REPAIR OF REAL ESTATE, RESIDENTIAL, INDUSTRIAL AND COMMERCIAL PROPERTIES, OFFICES, BUSINESS CENTERS, DEPARTMENTAL STORES, SHOPPING CENTERS, RETAIL AND WHOLESALE OUTLETS, TEMPORARY ACCOMMODATION, HOTELS, MOTELS, RESORTS, SERVICE APARTMENTS, BUILDINGS, HOUSES, CONDOMINIUMS, APARTMENTS, FLATS, WAREHOUSES, FACTORIES AND DEVELOPMENTS; REAL ESTATE DEVELOPMENT; REAL ESTATE SITE SELECTION; ADVISORY AND CONSULTANCY SERVICES RELATING TO THE AFORESAID (U.S. CLS. 100, 103 AND 106).

FIRST USE 12-0-1994; IN COMMERCE 12-0-1994.
KELLY BOULTON, EXAMINING ATTORNEY

SN 85-318,415. PLY GEM INDUSTRIES, INC., CARY, NC. FILED 5-11-2011.

DESIGNED EXTERIOR

THE MARK CONSISTS OF STANDARD CHARACTERS WITHOUT CLAIM TO ANY PARTICULAR FONT, STYLE, SIZE, OR COLOR.

CLASS 6—METAL GOODS

FOR METAL BUILDING MATERIALS, NAMELY, SOFFITS, FASCIA, TRIM, TRIM SHEET, SHUTTERS, SIDING, ROOF VENTS FOR HEATING, COOLING AND VENTILATION IN RESIDENTIAL AND COMMERCIAL BUILDINGS, GUTTER COIL, GUTTERS AND GUTTER GUARDS, ENTRY AND PATIO DOORS, WINDOWS (U.S. CLS. 2, 12, 13, 14, 23, 25 AND 50).

CLASS 19—NON-METALLIC BUILDING MATERIALS

FOR NON-METAL BUILDING MATERIALS, NAMELY, MANUFACTURED STONE AND BRICK VENEER FOR USE ON INTERIOR AND EXTERIOR WALLS, FLOORS AND SURFACES, VINYL SIDING, POLYPROPYLENE SIDING, NON-METAL BUILDING PRODUCTS, NAMELY, SOFFIT, FASCIA, SHUTTERS, SIDING, TRIM, AND MOUNTS IN THE NATURE OF NON-METAL STRUCTURES FOR MOUNTING ELECTRICAL OUTLETS, FACETS, LIGHT FIXTURES AND METERS; NON-METAL BUILDING PRODUCTS, NAMELY, NON-METAL VENTS FOR DRYERS, FOUNDATIONS, RANGE HOODS, ROOFS AND GABLES FOR HEATING, COOLING AND VENTILATION; NON-METAL FENCE PANELS, SLATS AND PICKETS, NON-METAL FENCE POSTS, NON-METAL RAILINGS FOR FENCES, NON-METAL WINDOWS, NON-METAL PATIO DOORS AND VINYL PATIO DOORS (U.S. CLS. 1, 12, 33 AND 50).

CLASS 42—SCIENTIFIC AND COMPUTER SERVICES

FOR HOME EXTERIOR ARCHITECTURAL DESIGN AND CONSULTING SERVICES (U.S. CLS. 100 AND 101). KATHERINE CONNOLLY, EXAMINING ATTORNEY

SN 85-318,463. SPORTS CONCUSSION INSTITUTE, LOS ANGELES, CA. FILED 5-11-2011.

**CERTIFIED SPORTS
CONCUSSION MANAGEMENT
(CSCM)**

THE MARK CONSISTS OF STANDARD CHARACTERS WITHOUT CLAIM TO ANY PARTICULAR FONT, STYLE, SIZE, OR COLOR.

NO CLAIM IS MADE TO THE EXCLUSIVE RIGHT TO USE "CERTIFIED SPORTS CONCUSSION MANAGEMENT", APART FROM THE MARK AS SHOWN.

CLASS 41—EDUCATION AND ENTERTAINMENT

FOR EDUCATIONAL EXAMINATION; EDUCATIONAL SERVICES, NAMELY, CONDUCTING CLASSES, SEMINARS, CONFERENCES, AND WORKSHOPS IN THE FIELD OF CONCUSSIONS AND INJURIES (U.S. CLS. 100, 101 AND 107).

CLASS 44—MEDICAL, BEAUTY AND AGRICULTURAL SERVICES

FOR HEALTH CARE SERVICES (U.S. CLS. 100 AND 101). NELSON SNYDER, EXAMINING ATTORNEY

SN 85-318,702. QUERCEGEN TECHNOLOGIES HOLDINGS LLC, SUDBURY, MA. FILED 5-11-2011.

JUICE@TEA

NO CLAIM IS MADE TO THE EXCLUSIVE RIGHT TO USE "TEA", APART FROM THE MARK AS SHOWN.

THE MARK CONSISTS OF THE TERMS "JUICE" AND "TEA" WITH A LOWER CASE "E" IN A CIRCLE IN BETWEEN THE TWO TERMS.

CLASS 5—PHARMACEUTICALS

FOR DIETETIC FOOD SUPPLEMENTS, FOOD AND NUTRITIONAL SUPPLEMENTS, VITAMINS, MINERAL SUPPLEMENTS, HERBAL SUPPLEMENTS; DIETARY SUPPLEMENTAL DRINKS; DIETARY SUPPLEMENTS; HOMEOPATHIC SUPPLEMENTS; MEAL REPLACEMENT AND DIETARY SUPPLEMENT DRINK MIXES; MEAL REPLACEMENT BARS; MEAL REPLACEMENT DRINKS; NUTRACEUTICALS FOR USE AS A DIETARY SUPPLEMENT; NUTRITIONAL ADDITIVES FOR MEDICAL PURPOSES FOR USE IN FOODS AND DIETARY SUPPLEMENTS FOR HUMAN CONSUMPTION; NUTRITIONAL DRINK MIX FOR USE AS A MEAL REPLACEMENT; SOY PROTEIN FOR USE AS A NUTRITIONAL INGREDIENT; MEDICATED CONFECTIONERY, MEDICATED CHEWING GUM; HERBAL TEA FOR MEDICAL PURPOSES; MEDICATED BEVERAGES; NUTRITIONALLY FORTIFIED BEVERAGES; ALL OF THE AFOREMENTIONED GOODS CONTAIN TEA OR EXTRACTS OF SAME (U.S. CLS. 6, 18, 44, 46, 51 AND 52).

CLASS 32—LIGHT BEVERAGES

FOR BREWED MALT-BASED ALCOHOLIC BEVERAGES IN THE NATURE OF A BEER, PREPARATIONS FOR MAKING MALT BEVERAGES; NON-ALCOHOLIC FRUIT JUICE BEVERAGES; AERATED WATERS, TABLE WATERS, MINERAL WATERS; FRUIT JUICES, FRUIT BEVERAGES, NON-ALCOHOLIC BEVERAGES, NAMELY, SPORTS DRINKS, SOFT DRINKS, CARBONATED BEVERAGES AND SOY-BASED BEVERAGES NOT BEING MILK SUBSTITUTES; ENERGY DRINKS; PREPARATIONS FOR MAKING FRUIT BEVERAGES, ENERGY DRINKS, SOFT DRINKS, SPORTS BEVERAGES AND NON-ALCOHOLIC BEVERAGES WITH TEA FLAVOR; NON-ALCOHOLIC MALT BEVERAGES; PREPARATIONS FOR MAKING MALT BEVERAGES; NON-ALCOHOLIC FRUIT JUICE-BASED BEVERAGES; ALL OF THE AFOREMENTIONED GOODS CONTAIN TEA OR EXTRACTS OF SAME (U.S. CLS. 45, 46 AND 48).

BRIDGETT SMITH, EXAMINING ATTORNEY

SN 85-318,706. QUERCEGEN TECHNOLOGIES HOLDINGS LLC, SUDBURY, MA. FILED 5-11-2011.

JUICY TEA

THE MARK CONSISTS OF STANDARD CHARACTERS WITHOUT CLAIM TO ANY PARTICULAR FONT, STYLE, SIZE, OR COLOR.

NO CLAIM IS MADE TO THE EXCLUSIVE RIGHT TO USE "TEA", APART FROM THE MARK AS SHOWN.

CLASS 5—PHARMACEUTICALS

FOR DIETETIC FOOD SUPPLEMENTS, FOOD AND NUTRITIONAL SUPPLEMENTS, VITAMINS, MINERAL SUPPLEMENTS, HERBAL SUPPLEMENTS; DIETARY SUPPLEMENTAL DRINKS; DIETARY SUPPLEMENTS; HOMEOPATHIC SUPPLEMENTS; MEAL REPLACEMENT AND DIETARY SUPPLEMENT DRINK MIXES; MEAL REPLACEMENT BARS; MEAL REPLACEMENT DRINKS; NUTRACEUTICALS FOR USE AS A DIETARY SUPPLEMENT; NUTRITIONAL ADDITIVES FOR MEDICAL PURPOSES FOR USE IN FOODS AND DIETARY SUPPLEMENTS FOR HUMAN CONSUMPTION; NUTRITIONAL DRINK MIX FOR USE AS A MEAL REPLACEMENT; SOY PROTEIN FOR USE AS A NUTRITIONAL INGREDIENT; MEDICATED CONFECTIONERY, MEDICATED CHEWING GUM; HERBAL TEA FOR MEDICINAL PURPOSES; MEDICATED BEVERAGES; NUTRITIONALLY FORTIFIED BEVERAGES; ALL OF THE AFOREMENTIONED GOODS CONTAIN TEA OR EXTRACTS OF SAME (U.S. CLS. 6, 18, 44, 46, 51 AND 52).

CLASS 32—LIGHT BEVERAGES

FOR BREWED MALT-BASED ALCOHOLIC BEVERAGES IN THE NATURE OF A BEER, PREPARATIONS FOR MAKING MALTED BEVERAGES; NON-ALCOHOLIC FRUIT JUICE BEVERAGES; AERATED WATERS, TABLE WATERS, MINERAL WATERS; FRUIT JUICES, FRUIT BEVERAGES, NON-ALCOHOLIC BEVERAGES, NAMELY, SPORTS DRINKS, SOFT DRINKS, CARBONATED BEVERAGES AND SOY-BASED BEVERAGES NOT BEING MILK SUBSTITUTES; ENERGY DRINKS; PREPARATIONS FOR MAKING FRUIT BEVERAGES, ENERGY DRINKS, SOFT DRINKS, SPORTS BEVERAGES AND NON-ALCOHOLIC BEVERAGES WITH TEA FLAVOR; NON-ALCOHOLIC MALT BEVERAGES; PREPARATIONS FOR MAKING MALTED BEVERAGES; NON-ALCOHOLIC FRUIT JUICE-BASED BEVERAGES; ALL OF THE AFOREMENTIONED GOODS CONTAIN TEA OR EXTRACTS OF SAME (U.S. CLS. 45, 46 AND 48).

BRIDGETT SMITH, EXAMINING ATTORNEY

SN 85-319,904. RCG ENTERPRISES, LLC, LAS VEGAS, NV. FILED 5-13-2011.

Django Reinhardt

THE MARK CONSISTS OF STANDARD CHARACTERS WITHOUT CLAIM TO ANY PARTICULAR FONT, STYLE, SIZE, OR COLOR.

THE NAME(S), PORTRAIT(S), AND/OR SIGNATURE(S) SHOWN IN THE MARK DOES NOT IDENTIFY A PARTICULAR LIVING INDIVIDUAL.

CLASS 9—ELECTRICAL AND SCIENTIFIC APPARATUS

FOR DIGITAL MUSIC DOWNLOADABLE FROM THE INTERNET; DOWNLOADABLE MP3 FILES, MP3 RECORDINGS, ON-LINE DISCUSSION BOARDS, WEBCASTS, WEBINARS AND PODCASTS FEATURING MUSIC, AUDIO BOOKS IN THE FIELD OF INSTRUCTION OF THE GYPSY JAZZ TECHNIQUE, AND NEWS BROADCASTS; DOWNLOADABLE MUSICAL SOUND RECORDINGS; DOWNLOADABLE RING TONES, GRAPHICS AND MUSIC VIA A GLOBAL COMPUTER NETWORK AND WIRELESS DEVICES; DOWNLOADABLE VIDEO RECORDINGS FEATURING MUSIC IN THE STYLE OF MUSICAL ARTISTS; DOWNLOADABLE MUSIC VIA THE INTERNET AND WIRELESS DEVICES; MUSICAL RECORDINGS; MUSICAL SOUND RECORDINGS; MUSICAL VIDEO RECORDINGS; PRE-RECORDED VIDEO TAPES FEATURING MUSIC; SOUND RECORDINGS FEATURING GYPSY JAZZ; VIDEO RECORDINGS FEATURING GYPSY JAZZ (U.S. CLS. 21, 23, 26, 36 AND 38).

CLASS 15—MUSICAL INSTRUMENTS

FOR CARRYING CASES FOR MUSICAL INSTRUMENTS; MUSICAL BOXES; MUSICAL INSTRUMENT ACCESSORIES, NAMELY, STANDS, CASES, CARRYING BAGS AND STORAGE BAGS; MUSICAL INSTRUMENT STRINGS; MUSICAL INSTRUMENTS, NAMELY, GUITARS; STRINGS FOR MUSICAL INSTRUMENTS (U.S. CLS. 2, 21 AND 36).

CLASS 25—CLOTHING

FOR BASEBALL CAPS; BASEBALL CAPS AND HATS; HOODED SWEAT SHIRTS; T-SHIRTS; TEE SHIRTS; TURTLE NECK SHIRTS (U.S. CLS. 22 AND 39).

CLASS 41—EDUCATION AND ENTERTAINMENT

FOR EDUCATIONAL AND ENTERTAINMENT SERVICES, NAMELY, CONDUCTING DEMONSTRATIONS IN THE FIELD OF JAZZ AND DISTRIBUTION OF COURSE MATERIALS IN CONNECTION THEREWITH, AND EDUCATION CONSULTING RELATED THERETO; EDUCATIONAL SERVICES, NAMELY, PROVIDING ONLINE INSTRUCTION IN THE FIELD OF JAZZ VIA AN ONLINE WEBSITE; ENTERTAINMENT AND EDUCATION SERVICES IN THE NATURE OF LIVE DANCE AND MUSICAL PERFORMANCES; ENTERTAINMENT AND EDUCATIONAL SERVICES, NAMELY, PROVIDING ADVICE AND INFORMATION FOR MUSIC, VIDEO AND FILM CONCEPT AND SCRIPT DEVELOPMENT; ENTERTAINMENT AND EDUCATIONAL SERVICES, NAMELY, THE PRESENTATION OF SEMINARS, WORKSHOPS AND PANEL DISCUSSIONS, AND ONGOING TELEVISION AND RADIO SHOWS ALL IN THE FIELD OF GYPSY JAZZ; ENTERTAINMENT IN THE NATURE OF AN ON-GOING SPECIAL VARIETY, NEWS, MUSIC OR COMEDY SHOW FEATURING HISTORY OF MUSICAL ARTISTS AND JAZZ BROADCAST OVER TELEVISION, SATELLITE, AUDIO, AND VIDEO MEDIA; ENTERTAINMENT IN THE NATURE OF VISUAL AND AUDIO PERFORMANCES BY MUSICIANS PLAYING JAZZ IN THE STYLE OF GYPSY JAZZ; ENTERTAINMENT IN THE NATURE OF VISUAL AND AUDIO PERFORMANCES, AND MUSICAL, VARIETY, NEWS AND COMEDY SHOWS; ENTERTAINMENT IN THE NATURE OF TRIBUTE CONCERTS; ENTERTAINMENT INFORMATION SERVICES, NAMELY, PROVIDING INFORMATION AND NEWS RELEASES ABOUT A MUSICAL ARTIST; ENTERTAINMENT SERVICES BY A MUSICAL ARTIST AND PRODUCER, NAMELY, MUSICAL COMPOSITION FOR OTHERS AND PRODUCTION OF MUSICAL SOUND RECORDINGS; ENTERTAINMENT SERVICES IN THE NATURE OF LIVE MUSICAL PERFORMANCES; ENTERTAINMENT SERVICES IN THE NATURE OF PRESENTING LIVE MUSICAL PERFORMANCES; ENTERTAINMENT SERVICES IN THE NATURE OF RECORDING, PRODUCTION AND POST-PRODUCTION SERVICES IN THE FIELD OF MUSIC; ENTERTAINMENT SERVICES, NAMELY, THE PRESENTATION OF LIVE CHRISTMAS MUSICAL PRODUCTIONS; ENTERTAINMENT, NAMELY, LIVE MUSIC

CONCERTS; ENTERTAINMENT, NAMELY, LIVE PERFORMANCES BY A MUSICAL BAND; ENTERTAINMENT, NAMELY, LIVE PERFORMANCES BY MUSICAL BANDS; LIVE PERFORMANCES BY A MUSICAL GROUP; MOTION PICTURE SONG PRODUCTION; MULTIMEDIA ENTERTAINMENT SERVICES IN THE NATURE OR RECORDING, PRODUCTION AND POST-PRODUCTION SERVICES IN THE FIELDS OF MUSIC, VIDEO, AND FILMS; MUSIC SELECTION SERVICES FOR USE IN TELEVISION, FILM, RADIO AND VIDEO GAMES; MUSIC VIDEO PRODUCTION; PLANNING ARRANGEMENT OF SHOWING MOVIES, SHOWS, PLAYS OR MUSICAL PERFORMANCES; PRESENTATION OF MUSICAL PERFORMANCE; PRODUCTION OF MUSICAL SOUND RECORDING; PRODUCTION OF MUSICAL VIDEOS; PRODUCTION OF SOUND AND MUSIC VIDEO RECORDINGS; PROVISION OF INFORMATION RELATING TO DISTRIBUTION OF TELEVISION SHOWS, MOTION PICTURE FILM AND RADIO SHOWS; PROVISION OF INFORMATION RELATING TO TELEVISION, MOTION PICTURE FILM, AUDIO AND RADIO PRODUCTION; THEATRICAL AND MUSICAL FLOOR SHOWS PROVIDED AT DISCOTHEQUES AND NIGHTCLUBS; THEATRICAL AND MUSICAL FLOOR SHOWS PROVIDED AT PERFORMANCE VENUES (U.S. CLS. 100, 101 AND 107).

CLASS 45—PERSONAL AND LEGAL SERVICES

FOR LICENSING OF THE USE OF MUSICAL ARTISTS, RELATING TO, RECORDING, DOWNLOADABLE DIGITAL MEDIA FILES, MUSICAL EDUCATIONAL AND ENTERTAINMENT SERVICES, MUSICAL INSTRUMENTS AND MUSICAL INSTRUMENT ACCESSORIES, CLOTHING, MUSICAL AND THEATRICAL PERFORMANCES AND EVENTS, AND FILM FEATURING, NAMELY, THE MUSIC AND/OR THEIR HISTORY AND LIFE STORY (U.S. CLS. 100 AND 101).

INGA ERVIN, EXAMINING ATTORNEY

SN 85-320,419. RACING TO REGISTER, MALVERN, PA. FILED 5-13-2011.

RACING TO REGISTER

THE MARK CONSISTS OF STANDARD CHARACTERS WITHOUT CLAIM TO ANY PARTICULAR FONT, STYLE, SIZE, OR COLOR.

CLASS 25—CLOTHING

FOR CLOTHING, NAMELY, T-SHIRTS, HATS, SWEATSHIRTS, TANK TOPS, JERSEYS, SHORTS, JACKETS, CAPS, VISORS, HEADBANDS, WRISTBANDS, UNIFORMS, PANTS, SOCKS (U.S. CLS. 22 AND 39).

FIRST USE 3-0-2010; IN COMMERCE 3-0-2010.

CLASS 35—ADVERTISING AND BUSINESS

FOR PROMOTING PUBLIC AWARENESS OF THE NEED FOR BONE MARROW AND BLOOD STEM CELL DONORS; BONE MARROW AND BLOOD STEM CELL DONOR RECRUITMENT SERVICES, NAMELY, PROMOTING PUBLIC AWARENESS OF THE NEED FOR BONE MARROW AND BLOOD STEM CELL DONORS (U.S. CLS. 100, 101 AND 102).

FIRST USE 9-1-2009; IN COMMERCE 9-1-2009.

CLASS 36—INSURANCE AND FINANCIAL

FOR CHARITABLE FUNDRAISING SERVICES (U.S. CLS. 100, 101 AND 102).

FIRST USE 9-1-2009; IN COMMERCE 9-1-2009.

CHRISTINE MARTIN, EXAMINING ATTORNEY

SN 85-320,601. THE RUSSIAN SCHOOL OF MATHEMATICS, INC., NEWTON, MA. FILED 5-13-2011.



NO CLAIM IS MADE TO THE EXCLUSIVE RIGHT TO USE "RUSSIAN SCHOOL OF MATHEMATICS", APART FROM THE MARK AS SHOWN.

THE COLOR(S) BLUE AND GREEN IS/ARE CLAIMED AS A FEATURE OF THE MARK.

THE MARK CONSISTS OF THE LETTERS "RSM" IN BLUE WITH A BLUE SINE WAVE ORIGINATING FROM THE LEFT LEG OF THE LETTER "M" AND SITTING ON AN X AND Y AXIS DEPICTED IN GREEN, THE WORDS "RUSSIAN SCHOOL OF MATHEMATICS" APPEARS IN BLUE UNDERNEATH "RSM".

CLASS 16—PAPER GOODS AND PRINTED MATTER

FOR EDUCATIONAL PUBLICATIONS, NAMELY, WORKBOOKS, WORKSHEETS, AND BINDERS IN THE FIELDS OF MATHEMATICS (U.S. CLS. 2, 5, 22, 23, 29, 37, 38 AND 50).

CLASS 41—EDUCATION AND ENTERTAINMENT

FOR EDUCATION SERVICES, NAMELY, PROVIDING MENTORING, TUTORING, CLASSES, SEMINARS AND WORKSHOPS IN THE FIELD OF MATHEMATICS (U.S. CLS. 100, 101 AND 107).

FIRST USE 3-1-2011; IN COMMERCE 3-1-2011.

JEFF DEFORD, EXAMINING ATTORNEY

SN 85-322,047. BOREALIS TECHNICAL LIMITED, GIBRALTAR, GIBRALTAR, FILED 5-16-2011.

Driving Aerospace

THE MARK CONSISTS OF STANDARD CHARACTERS WITHOUT CLAIM TO ANY PARTICULAR FONT, STYLE, SIZE, OR COLOR.

NO CLAIM IS MADE TO THE EXCLUSIVE RIGHT TO USE "AEROSPACE", APART FROM THE MARK AS SHOWN.

CLASS 7—MACHINERY

FOR ELECTRIC MOTORS FOR MACHINES (U.S. CLS. 13, 19, 21, 23, 31, 34 AND 35).

FIRST USE 6-13-2009; IN COMMERCE 6-13-2009.

CLASS 9—ELECTRICAL AND SCIENTIFIC APPARATUS

FOR ELECTRIC CONTROL PANELS (U.S. CLS. 21, 23, 26, 36 AND 38).
FIRST USE 6-13-2009; IN COMMERCE 6-13-2009.
CURTIS FRENCH, EXAMINING ATTORNEY

SN 85-322,107. BOREALIS TECHNICAL LIMITED, GIBRALTAR, GIBRALTAR, FILED 5-16-2011.



THE COLOR(S) BLACK AND YELLOW IS/ARE CLAIMED AS A FEATURE OF THE MARK.
THE MARK CONSISTS OF BLACK SILHOUETTE OF AIRCRAFT WITH ARROW POINTING FORWARDS AND BACKWARDS ON YELLOW FIELD.

CLASS 7—MACHINERY

FOR ELECTRIC MOTORS FOR MACHINES (U.S. CLS. 13, 19, 21, 23, 31, 34 AND 35).
FIRST USE 6-13-2009; IN COMMERCE 6-13-2009.

CLASS 9—ELECTRICAL AND SCIENTIFIC APPARATUS

FOR ELECTRIC CONTROL PANELS (U.S. CLS. 21, 23, 26, 36 AND 38).
FIRST USE 6-13-2009; IN COMMERCE 6-13-2009.
CURTIS FRENCH, EXAMINING ATTORNEY

SN 85-322,286. BOUCARD, JOHN, DANVILLE, CA. FILED 5-16-2011.

PAPERCLIX

THE MARK CONSISTS OF STANDARD CHARACTERS WITHOUT CLAIM TO ANY PARTICULAR FONT, STYLE, SIZE, OR COLOR.

CLASS 9—ELECTRICAL AND SCIENTIFIC APPARATUS

FOR COMPUTER SOFTWARE THAT ALLOWS USERS TO ACTIVATE AND ACCESS COLLECTIONS OF RELEVANT DIGITAL CONTENT ASSOCIATED WITH A PHYSICAL PRODUCT (U.S. CLS. 21, 23, 26, 36 AND 38).

CLASS 16—PAPER GOODS AND PRINTED MATTER

FOR PHOTOGRAPH ALBUMS; SCRAPBOOKS; PHOTOS; GREETING CARDS; INVITATION CARDS; CALENDARS; BUSINESS CARDS; STICKERS; STORY BOOKS; POSTERS; DRAWING PADS; COLORING BOOKS; STATIONERY; DRY ERASE WRITING BOARDS AND WRITING SURFACES; STICK-ON WHITEBOARDS AND DRY-ERASE BOARDS (U.S. CLS. 2, 5, 22, 23, 29, 37, 38 AND 50).

CLASS 20—FURNITURE AND ARTICLES NOT OTHERWISE CLASSIFIED

FOR DISPLAY BOARDS; SIGNBOARDS OF WOOD OR PLASTICS (U.S. CLS. 2, 13, 22, 25, 32 AND 50).

CLASS 28—TOYS AND SPORTING GOODS

FOR TOY BUILDING BLOCKS; TOY BUILDING BLOCKS CAPABLE OF INTERCONNECTION; EDUCATIONAL TOYS IN THE NATURE OF AN ILLUSTRATED, INTERACTIVE WALL MAPS AND GENERAL PICTURE DIAGRAMS; ELECTRONIC LEARNING TOYS; CHILDREN'S MULTIPLE ACTIVITY TOYS; CHILDREN'S MULTIPLE ACTIVITY TOYS SOLD AS A UNIT WITH PRINTED BOOKS; CHILDREN'S ACTIVITY TABLES CONTAINING MANIPULATIVE TOYS WHICH CONVERT TO EASELS; TOY MODEL HOBBY CRAFT KITS; DRAWING TOYS (U.S. CLS. 22, 23, 38 AND 50).

CLASS 42—SCIENTIFIC AND COMPUTER SERVICES

FOR PROVIDING A WEB SITE FEATURING NON-DOWNLOADABLE SOFTWARE THAT ENABLES USERS TO UPLOAD, AGGREGATE AND CURATE COLLECTIONS OF RELEVANT DIGITAL CONTENT ASSOCIATED WITH A PHYSICAL PRODUCT (U.S. CLS. 100 AND 101).

LINDA POWELL, EXAMINING ATTORNEY

SN 85-323,372. AMERICAN INTERNATIONAL INDUSTRIES, COMMERCE, CA. FILED 5-17-2011.

3 SECOND

THE MARK CONSISTS OF STANDARD CHARACTERS WITHOUT CLAIM TO ANY PARTICULAR FONT, STYLE, SIZE, OR COLOR.

CLASS 3—COSMETICS AND CLEANING PREPARATIONS

FOR COSMETIC PREPARATIONS FOR THE EYE, ARTIFICIAL EYELASHES, ARTIFICIAL INDIVIDUAL EYELASHES, ADHESIVES FOR AFFIXING ARTIFICIAL EYELASHES, ADHESIVES FOR AFFIXING INDIVIDUAL ARTIFICIAL EYELASHES, EYELASH ADHESIVE REMOVER, EYEBROW GEL, EYEBROW COSMETICS, EYEBROW PENCIL (U.S. CLS. 1, 4, 6, 50, 51 AND 52).

CLASS 8—HAND TOOLS

FOR ARTIFICIAL EYELASH APPLICATORS IN THE NATURE OF A TWEEZER TOOL, EYELASH CURLER, TWEEZERS, EYEBROW TRIMMER (U.S. CLS. 23, 28 AND 44).

SHAILA SETTLES, EXAMINING ATTORNEY

SN 85-325,875. ALLDRIVE BRAND, S.L., 28010 MADRID, SPAIN, FILED 5-20-2011.

 The logo for AllDRIVE features the word "AllDRIVE" in a purple, sans-serif font. The letter "A" is stylized with a vertical bar extending upwards from its top, creating a unique graphic element.

PRIORITY CLAIMED UNDER SEC. 44(D) ON ERPN CMNTY TM OFC APPLICATION NO. 9961426, FILED 5-12-2011, REG. NO. 009961426, DATED 10-17-2011, EXPIRES 5-12-2021.

THE COLOR(S) MAUVE IS/ARE CLAIMED AS A FEATURE OF THE MARK.

THE MARK CONSISTS OF THE STYLIZED WORD "ALLDRIVE" APPEARING IN MAUVE.

CLASS 9—ELECTRICAL AND SCIENTIFIC APPARATUS

FOR CENTRAL PROCESSING UNITS FOR PROCESSING INFORMATION, DATA, SOUND OR IMAGES; COMPUTER SOFTWARE FOR USE IN THE ENCRYPTION AND DECRYPTION OF DIGITAL FILES, INCLUDING AUDIO, VIDEO, TEXT, BINARY, STILL IMAGES, GRAPHICS AND MULTIMEDIA FILES; COMPUTER SOFTWARE FOR PROCESSING DIGITAL IMAGES; COMPUTER SOFTWARE TO ENHANCE THE AUDIO-VISUAL CAPABILITIES OF MULTIMEDIA APPLICATIONS, NAMELY, FOR THE INTEGRATION OF TEXT, AUDIO, GRAPHICS, STILL IMAGES AND MOVING PICTURES (U.S. CLS. 21, 23, 26, 36 AND 38).

CLASS 42—SCIENTIFIC AND COMPUTER SERVICES

FOR COMPUTER SERVICES, NAMELY, DIGITAL FORMATTING AND COMPRESSION OF MUSIC AND VIDEO IMAGES INTO DOWNLOADABLE MEDIA; COMPUTER SERVICES, NAMELY, INTERACTIVE HOSTING SERVICES WHICH ALLOW THE USER TO PUBLISH AND SHARE THEIR OWN CONTENT AND IMAGES ON-LINE; DEVELOPMENT AND DESIGN OF DIGITAL SOUND AND IMAGE CARRIERS; IMAGE PROCESSING SOFTWARE DESIGN; COMPUTER SOFTWARE DESIGN, COMPUTER PROGRAMMING, AND MAINTENANCE OF COMPUTER SOFTWARE (U.S. CLS. 100 AND 101).

CURTIS FRENCH, EXAMINING ATTORNEY

SN 85-327,354. JIC FOODS, LLC, HAWTHORNE, CA. FILED 5-23-2011.

 The logo for sansai features the word "sansai" in a white, lowercase, sans-serif font. The text is set within a red rounded rectangle. A small green leaf-like shape is positioned in the upper right corner of the red rectangle.

OWNER OF U.S. REG. NOS. 3,219,349 AND 3,382,708. THE COLOR(S) RED, WHITE AND GREEN IS/ARE CLAIMED AS A FEATURE OF THE MARK.

THE MARK CONSISTS OF THE WORD "SANSAI" IN WHITE LOWERCASE FONT WITHIN A RED RECTANGLE HAVING ROUNDED EDGES, CONNECTED TO THE "I" IN "SANSAI" IN THE UPPER RIGHT CORNER OF THE MARK, IS A SMALL GREEN LEAF-LIKE SHAPE.

THE ENGLISH TRANSLATION OF "SANSAI" IN THE MARK IS "WILD MOUNTAIN VEGETABLE".

CLASS 29—MEATS AND PROCESSED FOODS

FOR SALADS EXCEPT MACARONI, RICE, AND PASTA SALAD; SOUPS; COMBINATION MEAL CONSISTING PRIMARILY OF A MEAT OR VEGETABLE-BASED ENTREE AND A SOUP OR SALAD FOR CONSUMPTION ON OR OFF THE PREMISES; SHRIMP AND VEGETABLE TEMPURA; STEAMED EDAMAME; PREPARED FOOD PACKAGES COMPOSED OF MEAT, POULTRY, FISH, SEAFOOD, EGG AND/OR VEGETABLES AND ALSO INCLUDING SAUCES OR SEASONINGS, READY TO BE EATEN AS A MEAL (U.S. CL. 46).

CLASS 30—STAPLE FOODS

FOR SPRING ROLLS; POTSTICKERS; SUSHI; PASTA SALAD AND RICE NOODLE SALAD, SANDWICHES (U.S. CL. 46).

CLASS 43—HOTEL AND RESTAURANT SERVICES

FOR RESTAURANT SERVICES, TAKEOUT RESTAURANT SERVICES AND CATERING SERVICES (U.S. CLS. 100 AND 101).

WON TEAK OH, EXAMINING ATTORNEY

SN 85-327,625. THE ADVISORY BOARD COMPANY, WASHINGTON, DC. FILED 5-23-2011.

 The logo is a stylized, bold, black letter "A". The top-left corner of the letter is missing, creating a unique, geometric shape.

THE MARK CONSISTS OF A STYLIZED "A" MISSING THE UPPER LEFT PART OF THE LETTER.

CLASS 9—ELECTRICAL AND SCIENTIFIC APPARATUS

FOR DOWNLOADABLE ELECTRONIC PUBLICATIONS IN THE FIELDS OF HEALTH CARE, EDUCATION AND PERSONNEL MANAGEMENT, NAMELY BRIEFINGS, REPORTS, SYNDICATED COLUMNS AND PRINTED DOCUMENTATION AND RESULTS REGARDING RESEARCH STUDIES (U.S. CLS. 21, 23, 26, 36 AND 38).

CLASS 16—PAPER GOODS AND PRINTED MATTER

FOR PRINTED PUBLICATIONS, IN THE FIELDS OF HEALTH CARE, EDUCATION AND PERSONNEL MANAGEMENT, NAMELY BRIEFINGS, REPORTS, SYNDICATED COLUMNS AND PRINTED DOCUMENTATION AND RESULTS REGARDING RESEARCH STUDIES (U.S. CLS. 2, 5, 22, 23, 29, 37, 38 AND 50).

CLASS 35—ADVERTISING AND BUSINESS

FOR BUSINESS CONSULTING, RESEARCH, MANAGEMENT AND ADVISORY SERVICES FOR OTHERS IN THE FIELDS OF OPERATIONAL AND MANAGEMENT PRACTICES, ADMINISTRATION AND SYSTEMS; HEALTH CARE FACILITY MANAGEMENT CONSULTATION AND BUSINESS RESEARCH FOR OTHERS CONCERNING THE MANAGEMENT OF HEALTH CARE FACILITIES, EDUCATIONAL INSTITUTES AND OTHER BUSINESS ENTITIES; INTERIM MANAGEMENT AND CONSULTATION SERVICES FOR HEALTH CARE PROVIDERS AND MANAGED CARE PROVIDER ORGANIZATIONS; BUSINESS CONSULTING AND RESEARCH SERVICES FOR OTHERS; BUSINESS CONSULTING AND RESEARCH SERVICES FOR OTHERS IN THE FIELDS OF HOSPITAL AND HEALTH CARE SYSTEM OPERATIONS AND MANAGEMENT, AND HOSPITAL AND MEDICAL COST MANAGEMENT; BUSINESS CONSULTING, RESEARCH AND ADVISORY SERVICES IN THE FIELD OF PHYSICIAN PERFORMANCE MANAGEMENT; PROFESSIONAL SERVICES IN THE FIELD OF HEALTH CARE, NAMELY, NURSING INFORMATICS IN THE NATURE OF PROVIDING RESEARCH AND INFORMATION IN THE FIELD OF NURSING MANAGEMENT FOR MEASURING AND EVALUATING BUSINESS AND ORGANIZATIONAL PERFORMANCE, PROMOTING THE ATTAINMENT OF SET WORKLOAD MANAGEMENT GOALS AND OUTCOMES, IMPROVING BUSINESS PRACTICES, AND FACILITATING PREPARATION FOR BUSINESS AND ORGANIZATIONAL ACCREDITATION; BUSINESS SERVICES, NAMELY, BUSINESS CONSULTATION IN THE FIELD OF BEST PRACTICES FOR HEALTH CARE FACILITY MANAGEMENT, HOSPITAL AND HEALTH CARE SYSTEM OPERATIONS AND MANAGEMENT, HOSPITAL AND MEDICAL COST MANAGEMENT, PHYSICIAN, NURSE AND MEDICAL PRACTITIONER MANAGEMENT, WORKLOAD MANAGEMENT, PERSONNEL MANAGEMENT, AND MANAGEMENT OF EDUCATIONAL INSTITUTES AND OTHER BUSINESS ENTITIES; PERSONNEL MANAGEMENT CONSULTATION; BUSINESS RESEARCH AND SURVEYS; BUSINESS RESEARCH CONSULTATION (U.S. CLS. 100, 101 AND 102).

CLASS 41—EDUCATION AND ENTERTAINMENT

FOR BUSINESS EDUCATION AND TRAINING SERVICES, NAMELY, CONDUCTING WORKSHOPS, SEMINARS AND PROGRAMS IN THE FIELD OF BEST PRACTICES FOR HEALTH CARE FACILITY MANAGEMENT, HOSPITAL AND HEALTH CARE SYSTEM OPERATIONS AND MANAGEMENT, HOSPITAL AND MEDICAL COST MANAGEMENT, PHYSICIAN, NURSE AND MEDICAL PRACTITIONER MANAGEMENT, WORKLOAD MANAGEMENT, PERSONNEL MANAGEMENT, MANAGEMENT OF EDUCATIONAL INSTITUTES AND OTHER BUSINESS ENTITIES, AND PERSONNEL MANAGEMENT CONSULTATION (U.S. CLS. 100, 101 AND 107).

FRED CARL, EXAMINING ATTORNEY

SN 85-327,706. VONAGE MARKETING LLC, HOLMDEL, NJ.
FILED 5-23-2011.



OWNER OF U.S. REG. NOS. 3,440,689, 3,681,594 AND 3,687,598.

THE MARK CONSISTS OF A STYLIZED "V" WITH A DOT.

CLASS 9—ELECTRICAL AND SCIENTIFIC APPARATUS

FOR (BASED ON INTENT TO USE) COMPUTER TELEPHONY SOFTWARE, NAMELY, SOFTWARE APPLICATIONS FOR ESTABLISHING AND PERFORMING PHONE CALLS, VIDEO CONFERENCING AND VIRTUAL VIDEO CONFERENCING OVER A VARIETY OF NETWORKS IN THE NATURE OF THE INTERNET; COMPUTER SOFTWARE AND HARDWARE FOR PROVIDING TRANSMISSION AND EXCHANGE OF VOICE, VIDEO, DATA, IMAGES AND GRAPHICS IN THE FIELDS OF TELECOMMUNICATIONS, VIDEO CONFERENCING AND VIRTUAL VIDEO CONFERENCING; DOWNLOADABLE SOFTWARE FOR USE WITH WIRELESS TELECOMMUNICATIONS DEVICES TO PROVIDE WIRELESS TRANSMISSION OF E-MAIL, TEXT, MUSIC, VIDEO, STILL IMAGES, INFORMATION, DATA, VIDEO CONFERENCING, VIRTUAL VIDEO CONFERENCING AND OTHER CONTENT VIA THE INTERNET AND VIA WIRELESS LOCAL AREA NETWORK DEVICES; (BASED ON USE IN COMMERCE) COMPUTER AND TELECOMMUNICATIONS NETWORK HUBS, SWITCHES AND ROUTERS; COMPUTER HARDWARE AND COMMUNICATIONS SOFTWARE FOR USE IN CONNECTING TELECOMMUNICATIONS EQUIPMENT, TELEPHONES, COMPUTERS, WIRED AND WIRELESS COMPUTER NETWORKS; (BASED ON USE IN COMMERCE) HARDWARE FOR TELECOMMUNICATIONS FOR CONNECTING DEVICES VIA IN-HOME PHONE AND ELECTRICAL WIRING, NAMELY, COMPUTER NETWORK HUBS, COMPUTER SWITCHES AND COMPUTER ROUTERS DESIGNED TO PROVIDE IN-HOME VOICE OVER INTERNET PROTOCOL (VOIP) COMMUNICATIONS; (BASED ON USE IN COMMERCE) DOWNLOADABLE SOFTWARE FOR USE WITH WIRELESS TELECOMMUNICATIONS DEVICES TO PROVIDE WIRELESS TRANSMISSION OF VOICE AND OTHER CONTENT VIA THE INTERNET AND VIA WIRELESS LOCAL AREA NETWORK DEVICES (U.S. CLS. 21, 23, 26, 36 AND 38).

FIRST USE 6-29-2006; IN COMMERCE 6-29-2006.

CLASS 38—COMMUNICATION

FOR (BASED ON INTENT TO USE) TELECONFERENCING SERVICES; VIDEO CONFERENCING AND VIRTUAL VIDEO CONFERENCING SERVICES; (BASED ON USE IN COMMERCE) TELEPHONY COMMUNICATIONS SERVICES (U.S. CLS. 100, 101 AND 104).

FIRST USE 6-29-2006; IN COMMERCE 6-29-2006.
VERNA BETH RIRIE, EXAMINING ATTORNEY

SN 85-329,158. OXFORD BIOMEDICA PLC, OXFORD OX4 4GA, UNITED KINGDOM, FILED 5-24-2011.

SN 85-329,697. GOEO, NEW YORK, NY. FILED 5-25-2011.

Go Humane. Go Healthy. Go Green.

PROCASTAT

THE MARK CONSISTS OF STANDARD CHARACTERS WITHOUT CLAIM TO ANY PARTICULAR FONT, STYLE, SIZE, OR COLOR.

OWNER OF ERPN CMNTY TM OFC REG. NO. 597286, DATED 11-17-1999, EXPIRES 8-5-2017.
OWNER OF U.S. REG. NO. 3,029,338.

CLASS 5—PHARMACEUTICALS

FOR (BASED ON 44(E)) (BASED ON INTENT TO USE) GENE THERAPY PRODUCTS, NAMELY, PHARMACEUTICAL PREPARATION VECTORS FOR USE IN GENE THERAPY, CLINICAL MEDICAL REAGENTS, THERAPEUTIC COMPOSITIONS CONTAINING VECTORS FOR GENE THERAPY FOR USE IN THE TREATMENT OF CANCER, NEUROLOGICAL, OCULAR, HEARING, BALANCE AND AUTO-IMMUNE DISORDERS; (BASED ON INTENT TO USE) PHARMACEUTICAL PREPARATIONS CONTAINING NUCLEIC ACIDS FOR USE IN THE TREATMENT OF VIRAL AND BACTERIAL INFECTIONS, CANCER, HIV AND AIDS-RELATED INFECTIONS AND BODILY CONDITIONS ASSOCIATED WITH IMPAIRED IMMUNOSYSTEMS, SINGLE GENE DISORDERS, HEMOPHILIA, BLOOD DISORDERS, VASCULAR DISORDERS AND DISORDERS ARISING FROM INAPPROPRIATE VASCULARIZATION, DISEASES OF THE NERVOUS SYSTEM, CARDIAC, OCULAR, HEARING AND BALANCE DISORDERS, INFLAMMATORY AND AUTO-IMMUNE DISEASES; PHARMACEUTICAL PREPARATIONS AND VACCINES FOR USE IN THE TREATMENT OF CANCER, SINGLE GENE DISORDERS, HEMOPHILIA, BLOOD DISORDERS, VASCULAR DISORDERS AND DISORDERS ARISING FROM INAPPROPRIATE VASCULARIZATION, DISEASES OF THE NERVOUS SYSTEM, CARDIAC, NEUROLOGICAL, OCULAR, HEARING, BALANCE AND AUTO-IMMUNE DISORDERS, INFLAMMATORY AND AUTO-IMMUNE DISEASES; ENZYMES AND ENZYMIC PREPARATIONS FOR MEDICAL USE IN THE TREATMENT OF BACTERIAL INFECTIONS; RETRO VIRAL VECTOR PREPARATIONS FOR MEDICAL USE IN THE TREATMENT OF CANCER; AND CHEMOTHERAPEUTICS FOR MEDICAL USE; (BASED ON 44(E)) ENZYMES AND ENZYME PREPARATIONS FOR GENE THERAPY PURPOSES, RETRO VIRAL VECTOR AND RETRO VIRAL VECTOR MANUFACTURING PREPARATIONS, ALL FOR THE FIELD OF GENE THERAPY, FOR THE TREATMENT OF PROSTATE CANCER, WITH THE EXCLUSION OF PRODUCTS INTENDED FOR THE TREATMENT OF CARDIOVASCULAR DISEASES (U.S. CLS. 6, 18, 44, 46, 51 AND 52).

CLASS 10—MEDICAL APPARATUS

FOR (BASED ON 44(E)) (BASED ON INTENT TO USE) INSTRUMENTS AND APPARATUS FOR THE ADMINISTRATION OF GENE THERAPY PRODUCTS, NAMELY, VIALS, SYRINGES, INJECTORS, PUMPS, CATHETERS, INDWELLING CATHETERS AND TUBES; AND SURGICAL AND MEDICAL APPARATUS AND INSTRUMENTS, NAMELY, SCALPELS, KNIVES, FORCEPS AND SURGICAL CLIPS;(BASED ON 44(E)); SURGICAL INSTRUMENTS (U.S. CLS. 26, 39 AND 44).
CHRISTINE COOPER, EXAMINING ATTORNEY

THE MARK CONSISTS OF STANDARD CHARACTERS WITHOUT CLAIM TO ANY PARTICULAR FONT, STYLE, SIZE, OR COLOR.

CLASS 35—ADVERTISING AND BUSINESS

FOR PROVIDING ONLINE CONSUMER INFORMATION VIA THE INTERNET CONCERNING THE ENVIRONMENTAL PRESERVATION BENEFITS OF PURSUING ETHICAL OMNIVORISM (U.S. CLS. 100, 101 AND 102).

FIRST USE 5-20-2011; IN COMMERCE 5-20-2011.

CLASS 44—MEDICAL, BEAUTY AND AGRICULTURAL SERVICES

FOR PROVIDING ONLINE INFORMATION VIA THE INTERNET IN THE FIELD OF ADOPTING HEALTHY LIVING AND LIFESTYLE WELLNESS RELATING TO ETHICAL OMNIVORISM; PROVIDING ONLINE INFORMATION VIA THE INTERNET CONCERNING THE PHYSICAL AND PSYCHOLOGICAL WELL - BEING OF ANIMALS AS A REASON FOR PURSUING ETHICAL OMNIVORISM (U.S. CLS. 100 AND 101).

FIRST USE 5-20-2011; IN COMMERCE 5-20-2011.

ANDREW RHIM, EXAMINING ATTORNEY

SN 85-329,736. GOEO, NEW YORK, NY. FILED 5-25-2011.

GoEO

THE MARK CONSISTS OF STANDARD CHARACTERS WITHOUT CLAIM TO ANY PARTICULAR FONT, STYLE, SIZE, OR COLOR.

CLASS 35—ADVERTISING AND BUSINESS

FOR PROVIDING ONLINE CONSUMER INFORMATION VIA THE INTERNET CONCERNING THE ENVIRONMENTAL PRESERVATION BENEFITS OF PURSUING ETHICAL OMNIVORISM (U.S. CLS. 100, 101 AND 102).

FIRST USE 5-20-2011; IN COMMERCE 5-20-2011.

CLASS 44—MEDICAL, BEAUTY AND AGRICULTURAL SERVICES

FOR PROVIDING ONLINE INFORMATION VIA THE INTERNET IN THE FIELD OF ADOPTING HEALTHY LIVING AND LIFESTYLE WELLNESS RELATING TO ETHICAL OMNIVORISM; PROVIDING ONLINE INFORMATION VIA THE INTERNET CONCERNING THE PHYSICAL AND PSYCHOLOGICAL WELL - BEING OF ANIMALS AS A REASON FOR PURSUING ETHICAL OMNIVORISM (U.S. CLS. 100 AND 101).

FIRST USE 5-20-2011; IN COMMERCE 5-20-2011.

ANDREW RHIM, EXAMINING ATTORNEY

SN 85-330,203. 4LIFE TRADEMARKS, LLC, SANDY, UT.
FILED 5-25-2011.



OWNER OF U.S. REG. NOS. 2,475,300, 3,922,645 AND OTHERS.

THE MARK CONSISTS OF "4LIFE" IN STYLIZED LETTERING WITH A SUN-LIKE DESIGN USED FOR THE DOT OF THE "I".

CLASS 5—PHARMACEUTICALS

FOR DIETARY AND NUTRITIONAL SUPPLEMENTS IN THE FORM OF CAPSULES, LIQUIDS, POWDERS, AND TABLETS CONTAINING HERBS; DIETARY AND NUTRITIONAL SUPPLEMENTS IN THE FORM OF CAPSULES, LIQUIDS, POWDERS, AND TABLETS CONTAINING EXTRACTS FROM HERBS (U.S. CLS. 6, 18, 44, 46, 51 AND 52).

FIRST USE 4-30-2000; IN COMMERCE 4-30-2000.

CLASS 30—STAPLE FOODS

FOR PLANT-BASED PROCESSED FOODS, NAMELY, PLANT BASED FOOD BEVERAGES CONTAINING HERBS; AND PLANT-BASED HEALTH FOODS, NAMELY, PROCESSED PLANT-BASED FOOD IN THE NATURE OF PROCESSED HERBS TO BE USED AS A BREAKFAST FOOD, SNACK FOOD OR INGREDIENT FOR MAKING OTHER FOODS (U.S. CL. 46).

FIRST USE 8-4-2009; IN COMMERCE 8-4-2009.
DOUGLAS LEE, EXAMINING ATTORNEY

SN 85-330,431. CARMELITA RESOURCES, LLC, SANGER, CA. FILED 5-25-2011.



THE MARK CONSISTS OF A STYLIZED VERSION OF A HUMAN FORMED BY A PLANT, HAVING TWO UPPER ARMS REACHING UPWARD AND OUTWARD WITH THREE DIFFERENT SIZED LEAF SHAPES EMANATING FROM THE RIGHT ARM, THE LOWER BODY ENDS IN A POINT, AND THE BODY HAS A SEPARATE CIRCULAR HEAD.

CLASS 19—NON-METALLIC BUILDING MATERIALS

FOR CONSTRUCTION MATERIALS, NAMELY, ASPHALT, CONCRETE, READY MIX CONCRETE, ROCKS AND GRAVEL (U.S. CLS. 1, 12, 33 AND 50).

CLASS 37—CONSTRUCTION AND REPAIR

FOR SAND AND GRAVEL EXCAVATION; MINING EXTRACTION (U.S. CLS. 100, 103 AND 106).

CLASS 40—MATERIAL TREATMENT

FOR SAND AND GRAVEL AGGREGATE PROCESSING; MANUFACTURING FOR OTHERS OF ASPHALTIC CONCRETE; MANUFACTURING FOR OTHERS OF PORTLAND CEMENT READY-MIX CONCRETE; RECYCLING OF ASPHALT AND CONCRETE MATERIAL (U.S. CLS. 100, 103 AND 106).

ANTHONY RINKER, EXAMINING ATTORNEY

SN 85-330,954. BRAZELL, ROBERT, SALT LAKE CITY, UT.
FILED 5-26-2011.

Idiot Economy

THE MARK CONSISTS OF STANDARD CHARACTERS WITHOUT CLAIM TO ANY PARTICULAR FONT, STYLE, SIZE, OR COLOR.

CLASS 16—PAPER GOODS AND PRINTED MATTER

FOR BOOKS, MAGAZINES, BROCHURES AND PAMPHLETS, AND OTHER PRINTED MATERIALS (U.S. CLS. 2, 5, 22, 23, 29, 37, 38 AND 50).

CLASS 38—COMMUNICATION

FOR PROVIDING AN ON-LINE FORUM FOR TRANSMISSION OF MESSAGES AMONG COMPUTER USERS CONCERNING THE BUYING, SELLING AND EXCHANGE OF USEFUL IDEAS (U.S. CLS. 100, 101 AND 104).

DOMINICK J. SALEMI, EXAMINING ATTORNEY

SN 85-330,959. M.C. GILL CORPORATION, EL MONTE, CA.
FILED 5-26-2011.

GILLINER

THE MARK CONSISTS OF STANDARD CHARACTERS WITHOUT CLAIM TO ANY PARTICULAR FONT, STYLE, SIZE, OR COLOR.

CLASS 17—RUBBER GOODS

FOR LAMINATES, PARTICULARLY A FIBERGLASS POLYESTER LAMINATE USED AS A STRUCTURAL MATERIAL IN THE MANUFACTURE OF FUEL TANKS; LAMINATES, PARTICULARLY A FIBERGLASS POLYESTER LAMINATE USED AS A STRUCTURAL MATERIAL IN THE MANUFACTURE OF CARGO BAY WALL LININGS (U.S. CLS. 1, 5, 12, 13, 35 AND 50).

FIRST USE 4-14-1960; IN COMMERCE 4-14-1960.

CLASS 19—NON-METALLIC BUILDING MATERIALS

FOR LAMINATES, PARTICULARLY A FIBERGLASS POLYESTER LAMINATE USED AS A STRUCTURAL MATERIAL, NAMELY, AS LAMINATE FLOORING (U.S. CLS. 1, 12, 33 AND 50).

FIRST USE 4-14-1960; IN COMMERCE 4-14-1960.

LINDSEY RUBIN, EXAMINING ATTORNEY

SN 85-331,227. AZARA HEALTHCARE, LLC, BURLINGTON, MA. FILED 5-26-2011.

AZARA

THE MARK CONSISTS OF STANDARD CHARACTERS WITHOUT CLAIM TO ANY PARTICULAR FONT, STYLE, SIZE, OR COLOR.

CLASS 35—ADVERTISING AND BUSINESS

FOR BUSINESS MANAGEMENT SERVICES, NAMELY, HEALTH CARE PRACTICE MANAGEMENT (U.S. CLS. 100, 101 AND 102).

CLASS 36—INSURANCE AND FINANCIAL

FOR FINANCIAL INFORMATION SERVICES IN THE FIELD OF HEALTH CARE FINANCIAL DATA (U.S. CLS. 100, 101 AND 102).

CLASS 42—SCIENTIFIC AND COMPUTER SERVICES

FOR APPLICATION SERVICE PROVIDER, NAMELY, HOSTING, MANAGING, DEVELOPING, AND MAINTAINING APPLICATIONS, SOFTWARE, AND WEB SITES, IN THE FIELDS OF REPORTING, ANALYZING HEALTH CARE, MEDICAL PRACTICE, AND HEALTH CARE FINANCIAL INFORMATION; APPLICATION SERVICE PROVIDER FEATURING DATABASE MANAGEMENT SOFTWARE IN THE NATURE OF ELECTRONIC MEDICAL RECORDS SOFTWARE, ELECTRONIC HEALTH RECORD SOFTWARE AND HEALTH CARE PRACTICE MANAGEMENT SOFTWARE (U.S. CLS. 100 AND 101).

TRACY WHITTAKER-BROWN, EXAMINING ATTORNEY

SN 85-331,791. BART-PLANGE, SELINA, NEW YORK, NY. FILED 5-26-2011.

MIMI PLANGE

THE MARK CONSISTS OF STANDARD CHARACTERS WITHOUT CLAIM TO ANY PARTICULAR FONT, STYLE, SIZE, OR COLOR.

THE NAME(S), PORTRAIT(S), AND/OR SIGNATURE(S) SHOWN IN THE MARK DOES NOT IDENTIFY A PARTICULAR LIVING INDIVIDUAL.

CLASS 14—JEWELRY

FOR BEADS FOR USE IN THE MANUFACTURE OF JEWELRY; BRACELETS; BROOCHES; CHARMS; COSTUME JEWELRY; DIAMOND JEWELRY; GEMSTONE JEWELRY; JEWELRY BROOCHES; JEWELRY CHAINS; JEWELRY FOR ATTACHMENT TO CLOTHING; JEWELRY WATCHES; JEWELRY, NAMELY, AMULETS; JEWELRY, NAMELY, ANKLETS; JEWELRY, NAMELY, STONE PENDANTS; LEATHER JEWELRY AND ACCESSORY BOXES; PRECIOUS AND SEMI-PRECIOUS CRYSTAL STONES AND BEADS FOR USE IN JEWELRY; RINGS; RINGS BEING JEWELRY; TIMEPIECES; WATCHES AND JEWELRY (U.S. CLS. 2, 27, 28 AND 50).

FIRST USE 2-15-2011; IN COMMERCE 2-15-2011.

CLASS 18—LEATHER GOODS

FOR HANDBAGS, PURSES AND WALLETS; LEATHER BAGS AND WALLETS; LEATHER HANDBAGS; LEATHER PURSES; LUGGAGE; UMBRELLAS AND PARASOLS (U.S. CLS. 1, 2, 3, 22 AND 41).

FIRST USE 2-15-2011; IN COMMERCE 2-15-2011.

CLASS 25—CLOTHING

FOR A-SHIRTS; BELTS; BLOUSES; BOTTOMS; CAMISOLES; CARDIGANS; CAT SUITS; CLOTHING, NAMELY, WRAP-AROUNDS; CORSETS; COVERUPS; DRESS SUITS; DRESSES; EYESHADES; FOOTWEAR; FOUNDATION GARMENTS; GARTERS; GLOVES AS CLOTHING; HATS; HEADBANDS; HEADWEAR; HOODS; HOSIERY; JACKETS; JUMP SUITS; LEATHER BELTS; LEATHER HEADWEAR; LEATHER SKIRTS; LEG WARMERS; LEGGINGS; LINGERIE; LOUNGEWEAR; MUFFLERS; MUFFS; NECKWEAR; PANTS; RAINWEAR; ROBES; SCARVES; SHAWLS AND HEAD-SCARVES; SHOES; SHOULDER WRAPS; SKIRT SUITS; SKIRTS AND DRESSES; SKIWEAR; SLEEPWEAR; SLIPPERS; SLIPS; SOCKS AND STOCKINGS; STOLERS; SUITS; SUSPENDERS; SWEATERS; SWIM SUITS; SWIMWEAR; T-SHIRTS; TIES; TIGHTS; TOPS; TUXEDOS; UNDERGARMENTS; UNDERWEAR; VESTS; WEARABLE GARMENTS AND CLOTHING, NAMELY, SHIRTS; WEDDING GOWNS; WRAPS (U.S. CLS. 22 AND 39).

FIRST USE 2-15-2011; IN COMMERCE 2-15-2011.

ALLISON SCHRODY, EXAMINING ATTORNEY

SN 85-331,864. COLLEGENET, INC., PORTLAND, OR. FILED 5-26-2011.

APPLYCAM

THE MARK CONSISTS OF STANDARD CHARACTERS WITHOUT CLAIM TO ANY PARTICULAR FONT, STYLE, SIZE, OR COLOR.

CLASS 38—COMMUNICATION

FOR PROVIDING ACCESS TO AN INTERACTIVE COMPUTER DATABASE IN THE FIELD OF SCHOOLS, COLLEGES, UNIVERSITIES, GRADUATE PROGRAMS, PROFESSIONAL PROGRAMS OR STUDY-ABROAD PROGRAMS AND OTHER EDUCATIONAL FACILITIES; TELECOMMUNICATIONS ROUTING SERVICES (U.S. CLS. 100, 101 AND 104).

CLASS 42—SCIENTIFIC AND COMPUTER SERVICES

FOR COMPUTER SERVICES, NAMELY, APPLICATION SERVICE PROVIDER FEATURING SOFTWARE FOR USE IN SEARCHING, PREPARATION, SUBMISSION AND PROCESSING OF FORMS FEATURING VIDEO, SOUND, MESSAGES AND DATA FOR BUSINESS, GOVERNMENT, EDUCATION INSTITUTIONS AND NON-PROFIT ENTITIES; PROVIDING ONLINE, NON-DOWNLOADABLE SOFTWARE TOOLS THAT ENABLE USERS TO CREATE, UPLOAD AND SHARE VIDEOS, SOUND, MESSAGES AND DATA; APPLICATION SERVICE PROVIDER SERVICES FEATURING SOFTWARE TOOLS FOR ON-LINE ACTIVITIES, NAMELY, SERVICES THAT ENABLE EDUCATIONAL INSTITUTIONS TO CREATE ELECTRONIC FORMS, TO CREATE RELATED ON-LINE FORM PROCESSING SERVICES THAT ALLOW OTHERS TO SUBMIT THE ELECTRONIC FORMS FOR PROCESSING AND TO RECEIVE INFORMATION ABOUT THE FORMS AND THEIR PROCESSING; APPLICATION SERVICE PROVIDER SERVICES FEATURING SOFTWARE TOOLS FOR ON-LINE ACTIVITIES, NAMELY, TOOLS USED TO ASSESS, PLAN FOR AND MANAGE FACILITY AND CAMPUS CAPACITY, SCHEDULING, SPACE AND RESOURCES; COMPUTER SERVICES, NAMELY, SOFTWARE DEVELOPMENT SERVICES FOR WORK FLOW AND TRANSACTION MANAGEMENT SOFTWARE TOOLS AND APPLICATIONS FOR USE WITH A LOCAL AREA NETWORK, WIDE-AREA NETWORK AND GLOBAL COMPUTER NETWORK; APPLICATION SERVICE PROVIDER SERVICES FEATURING SOFTWARE TOOLS FOR ON-LINE ACTIVITIES, NAMELY, SEARCHING, FORM PROCESSING, DOCUMENT MANAGEMENT PROCESSING (U.S. CLS. 100 AND 101).

SAMUEL E. SHARPER JR., EXAMINING ATTORNEY

SN 85-334,391. PARKER RANCH, INC., KAMUELA, HI. FILED 5-31-2011.

BORN AND RAISED ON HAWAIIAN GRASS

THE MARK CONSISTS OF STANDARD CHARACTERS WITHOUT CLAIM TO ANY PARTICULAR FONT, STYLE, SIZE, OR COLOR.

CLASS 29—MEATS AND PROCESSED FOODS

FOR BEEF (U.S. CL. 46).

CLASS 44—MEDICAL, BEAUTY AND AGRICULTURAL SERVICES

FOR ANIMAL HUSBANDRY (U.S. CLS. 100 AND 101). DAVID I, EXAMINING ATTORNEY

SN 85-335,082. TIGERS POLYMER CORPORATION, TOYONAKA-SHI, OSAKA, JAPAN, FILED 6-1-2011.

SN 85-334,256. BAGOوبا, INC., NEW YORK, NY. FILED 5-31-2011.

WeChi

THE MARK CONSISTS OF STANDARD CHARACTERS WITHOUT CLAIM TO ANY PARTICULAR FONT, STYLE, SIZE, OR COLOR.

CLASS 41—EDUCATION AND ENTERTAINMENT

FOR ENTERTAINMENT SERVICES, NAMELY, PROVIDING ONLINE ELECTRONIC GAMES; ENTERTAINMENT SERVICES, NAMELY, PROVIDING VIRTUAL ENVIRONMENTS IN WHICH USERS CAN INTERACT FOR RECREATIONAL, LEISURE OR ENTERTAINMENT PURPOSES (U.S. CLS. 100, 101 AND 107).

CLASS 45—PERSONAL AND LEGAL SERVICES

FOR ON-LINE SOCIAL NETWORKING SERVICES (U.S. CLS. 100 AND 101). DAVID MURRAY, EXAMINING ATTORNEY

TIGERFLEX

THE MARK CONSISTS OF STANDARD CHARACTERS WITHOUT CLAIM TO ANY PARTICULAR FONT, STYLE, SIZE, OR COLOR.

OWNER OF U.S. REG. NO. 1,007,392.

CLASS 9—ELECTRICAL AND SCIENTIFIC APPARATUS

FOR ELECTRICAL CONDUITS, UNDERGROUND CONDUITS FOR ELECTRICAL POWER CABLES, SIGNAL CABLES OR OPTIC FIBER CABLES; PROTECTIVE CABLE SHEATHS FOR ELECTRICAL POWER CABLES, SIGNAL CABLES OR OPTIC FIBER CABLES; CABLES, NAMELY, ELECTRICAL CABLES AND CABLES FOR ELECTRICAL OR OPTICAL SIGNAL TRANSMISSION (U.S. CLS. 21, 23, 26, 36 AND 38).

FIRST USE 3-8-1996; IN COMMERCE 3-8-1996.

CLASS 17—RUBBER GOODS

FOR HOSES, NAMELY, PLASTIC AND RUBBER HOSES FOR FOOD TRANSFER SYSTEMS, HEAT PROTECTOR, HOT WATER CIRCULATORS, HOT AIR TRANSFER SYSTEMS, WATER, OIL OR SLURRY DELIVERY SYSTEMS, POWDER, GRAIN OR PELLET TRANSFER SYSTEMS, CIVIL ENGINEERING, INDUSTRIAL PLANTS, AUTOMOBILES, VACUUM CLEANERS, WASHING MACHINES, AIR CONDITIONERS; TUBES, NAMELY, PLASTIC TUBES FOR LABORATORY APPARATUS AND INSTRUMENTS, VENDING MACHINES, SEMICONDUCTOR MANUFACTURING EQUIPMENTS, FOOD TRANSFER SYSTEMS, HEAT PROTECTOR, HOT WATER CIRCULATOR, HOT AIR TRANSFER SYSTEMS, WATER, OIL OR SLURRY DELIVERY SYSTEMS, OFFICE MACHINES, WASHING MACHINES, AIR CONDITIONERS AND RUBBER TUBES (U.S. CLS. 1, 5, 12, 13, 35 AND 50).

FIRST USE 4-0-1974; IN COMMERCE 4-0-1974.

JUSTINE D. PARKER, EXAMINING ATTORNEY

SN 85-336,076. THE OMNIA GROUP, INC., TAMPA, FL.
FILED 6-2-2011.



OWNER OF U.S. REG. NO. 2,124,963.

THE MARK CONSISTS OF THE LETTER "O", WHICH IS THE FIRST LETTER OF THE WORD OMNIA, WHICH IS PART OF OUR COMPANY NAME, WITH AN IMAGE WITHIN THE LETTER "O". THE IMAGE IS A COMBINATION OF THREE GEOMETRIC SHAPES REPRESENTING A PERSON; TWO SIDEWAY LETTER V'S WITH A FILLED-IN CIRCLE ABOVE THEM.

CLASS 16—PAPER GOODS AND PRINTED MATTER

FOR PUBLICATIONS, NAMELY, BROCHURES, BOOKLETS, AND TEACHING MATERIALS IN THE FIELD OF PERSONALITY TESTING (U.S. CLS. 2, 5, 22, 23, 29, 37, 38 AND 50).

FIRST USE 1-1-2010; IN COMMERCE 1-1-2010.

CLASS 35—ADVERTISING AND BUSINESS

FOR BUSINESS CONSULTING SERVICES IN THE FIELD OF PERSONALITY TESTING; PERSONALITY TESTING FOR BUSINESS PURPOSES (U.S. CLS. 100, 101 AND 102).

FIRST USE 7-1-2010; IN COMMERCE 7-1-2010.

CLASS 41—EDUCATION AND ENTERTAINMENT

FOR EDUCATIONAL SERVICES, NAMELY, CONDUCTING CONFERENCES, SEMINARS, WORKSHOPS IN THE FIELD OF PERSONALITY TESTING AND DISTRIBUTION OF PRINTED MATERIALS IN CONNECTION THEREWITH IN HARD COPY OR ELECTRONIC FORMAT ON THE SAME TOPICS (U.S. CLS. 100, 101 AND 107).

FIRST USE 1-1-2011; IN COMMERCE 1-1-2011.

AISHA CLARKE, EXAMINING ATTORNEY

SN 85-336,133. BAD MEETS EVIL, LLC, NEW YORK, NY.
FILED 6-2-2011.

BAD MEETS EVIL

THE MARK CONSISTS OF STANDARD CHARACTERS WITHOUT CLAIM TO ANY PARTICULAR FONT, STYLE, SIZE, OR COLOR.

CLASS 25—CLOTHING

FOR CLOTHING, NAMELY, SUITS, SPORTS JACKETS, BLAZERS, JACKETS, COATS, OVER COATS, TRENCH COATS, SPORT COATS, RAINCOATS, SHIRTS, TIES, BELTS, JERSEYS, T-SHIRTS, TOPS, VESTS, SWEATERS, PANTS, TROUSERS, JEANS, SHORTS, SWEATSHIRTS, SWEATPANTS, WARM UP SUITS, CAPS, HATS, VISORS, SWEAT BANDS, HEADBANDS, BANDANAS, SCARVES, HOSIERY, SOCKS, FOOTWEAR, UNDERWEAR, BRIEFS, BOXER SHORTS, UNDERSHIRTS, TANK TOPS, ROBES, PAJAMAS, PAJAMA PANTS, PAJAMA TOPS, SLEEP SHIRTS, SWIMSUITS, GLOVES (U.S. CLS. 22 AND 39).

CLASS 41—EDUCATION AND ENTERTAINMENT

FOR ENTERTAINMENT SERVICES IN THE NATURE OF LIVE MUSICAL PERFORMANCES; MUSIC PRODUCTION; MUSIC VIDEO PRODUCTION; ENTERTAINMENT SERVICES IN THE NATURE OF RECORDING, PRODUCTION AND POST-PRODUCTION SERVICES IN THE FIELD OF MUSIC (U.S. CLS. 100, 101 AND 107).

LOURDES AYALA, EXAMINING ATTORNEY

SN 85-337,058. SLESSOR, DONALD BRUCE, KESWICK, CANADA, FILED 6-3-2011.

SPIRIT YOUR REALITY

THE MARK CONSISTS OF STANDARD CHARACTERS WITHOUT CLAIM TO ANY PARTICULAR FONT, STYLE, SIZE, OR COLOR.

CLASS 16—PAPER GOODS AND PRINTED MATTER

FOR PRINTED EDUCATIONAL MATERIALS IN THE FIELD OF LIFE AND SPIRIT ENHANCEMENT (U.S. CLS. 2, 5, 22, 23, 29, 37, 38 AND 50).

CLASS 41—EDUCATION AND ENTERTAINMENT

FOR EDUCATIONAL SERVICES, NAMELY, PROVIDING ONLINE CLASSES AND SEMINARS IN THE FIELD OF LIFE COACHING AND SPIRITUAL ENHANCEMENT AND DISTRIBUTION OF PRINTED COURSE MATERIALS IN CONNECTION THEREWITH; PROVIDING EDUCATIONAL COURSES IN THE FIELD OF LIFE COACHING AND SPIRITUAL ENHANCEMENT OFFERED THROUGH ONLINE, NON-DOWNLOADABLE VIDEOS (U.S. CLS. 100, 101 AND 107).

JASON TURNER, EXAMINING ATTORNEY

SN 85-337,275. COLUMBIA UNIVERSITY PRESS, NEW YORK, NY. FILED 6-3-2011.

Wallflower Press

THE MARK CONSISTS OF STANDARD CHARACTERS WITHOUT CLAIM TO ANY PARTICULAR FONT, STYLE, SIZE, OR COLOR.

NO CLAIM IS MADE TO THE EXCLUSIVE RIGHT TO USE "PRESS", APART FROM THE MARK AS SHOWN.

CLASS 9—ELECTRICAL AND SCIENTIFIC APPARATUS

FOR DOWNLOADABLE ELECTRONIC PUBLICATIONS IN THE NATURE OF SCHOLARLY AND REFERENCE BOOKS CONTAINING GENERAL INFORMATION ON FILM, TV, VIDEO, DIRECTORS, PERFORMERS, CAMERA TECHNIQUES AND POPULAR CULTURE; BOOKS, PAMPHLETS ALL BEING OF A TRADE, SCHOLARLY AND PROFESSIONAL NATURE; DOWNLOADABLE ELECTRONIC PUBLICATIONS IN THE NATURE OF BOOKS AND PAMPHLETS, ALL BEING OF A TRADE, SCHOLARLY AND PROFESSIONAL NATURE IN THE FIELD OF FILM, TV, VIDEO, DIRECTORS, PERFORMERS, CAMERA TECHNIQUES AND POPULAR CULTURE (U.S. CLS. 21, 23, 26, 36 AND 38).

CLASS 41—EDUCATION AND ENTERTAINMENT

FOR ONLINE ELECTRONIC PUBLISHING SERVICES, NAMELY, PROVIDING A WEBSITE FEATURING NON-DOWNLOADABLE PUBLICATIONS IN THE NATURE OF IN THE NATURE OF SCHOLARLY AND REFERENCE BOOKS CONTAINING GENERAL INFORMATION ON FILM, TV, VIDEO, DIRECTORS, PERFORMERS, CAMERA TECHNIQUES AND POPULAR CULTURE; PROVIDING A WEBSITE FEATURING NON-DOWNLOADABLE PUBLICATIONS IN THE NATURE OF BOOKS, PAMPHLETS, ALL BEING OF A TRADE, SCHOLARLY AND PROFESSIONAL NATURE IN THE FIELD OF FILM, TV, VIDEO, DIRECTORS, PERFORMERS, CAMERA TECHNIQUES AND POPULAR CULTURE (U.S. CLS. 100, 101 AND 107).

THEODORE MCBRIDE, EXAMINING ATTORNEY

SN 85-337,637. PPG INDUSTRIES OHIO, INC., CLEVELAND, OH. FILED 6-3-2011.

BRINGING INNOVATION TO THE
SURFACE

THE MARK CONSISTS OF STANDARD CHARACTERS WITHOUT CLAIM TO ANY PARTICULAR FONT, STYLE, SIZE, OR COLOR.

CLASS 1—CHEMICALS

FOR ADHESIVES FOR INDUSTRIAL USE; SILICON DIOXIDE FOR USE IN THE FURTHER MANUFACTURE OF GOODS; CHEMICAL COMPOUNDS USED TO PRETREAT METAL SURFACES TO IMPROVE THE ADHESION OF COATINGS AND IMPROVE CORROSION RESISTANCE; CHEMICALS FOR WATER AND WASTE-WATER TREATMENT; OPTICAL MONOMER FOR THE MANUFACTURE OF LENSES AND LENS BLANKS (U.S. CLS. 1, 5, 6, 10, 26 AND 46).

CLASS 2—PAINTS

FOR PAINTS AND PIGMENTS (U.S. CLS. 6, 11 AND 16).

CLASS 12—VEHICLES

FOR VEHICLE PARTS, NAMELY, WINDOWS FOR LAND, SEA AND AIR VEHICLES (U.S. CLS. 19, 21, 23, 31, 35 AND 44).

CLASS 17—RUBBER GOODS

FOR PLASTIC MICROPOROUS SHEETS FOR GENERAL USE; ADHESIVE SEALANT AND CAULKING COMPOUND (U.S. CLS. 1, 5, 12, 13, 35 AND 50).

CLASS 19—NON-METALLIC BUILDING MATERIALS

FOR BUILDING GLASS, NAMELY, FLAT, FLOAT AND SHEET GLASS (U.S. CLS. 1, 12, 33 AND 50).

CLASS 21—HOUSEWARES AND GLASS

FOR FIBERGLASS OTHER THAN FOR INSULATION OR TEXTILE USE (U.S. CLS. 2, 13, 23, 29, 30, 33, 40 AND 50).

CLASS 35—ADVERTISING AND BUSINESS

FOR BUSINESS MANAGEMENT AND CONSULTING SERVICES AND PROVIDING INFORMATION IN THE FIELDS OF THE GLASS, FIBERGLASS, CHEMICAL, COATING AND EYEGLASS LENS INDUSTRIES (U.S. CLS. 100, 101 AND 102).

CHARLES L. JENKINS, EXAMINING ATTORNEY

SN 85-338,524. ALLIED DOMECQ SPIRITS & WINE LIMITED, LONDON, UNITED KINGDOM, FILED 6-6-2011.

LONG JOHN

THE MARK CONSISTS OF STANDARD CHARACTERS WITHOUT CLAIM TO ANY PARTICULAR FONT, STYLE, SIZE, OR COLOR.

PRIORITY CLAIMED UNDER SEC. 44(D) ON ERP CMNTY TM OFC APPLICATION NO. 009772633, FILED 3-1-2011, REG. NO. 009772633, DATED 7-13-2011, EXPIRES 7-13-2021.

CLASS 32—LIGHT BEVERAGES

FOR BEERS; MINERAL AND AERATED WATERS AND OTHER NON-ALCOHOLIC DRINKS; FRUIT DRINKS AND FRUIT JUICES; SYRUPS AND OTHER PREPARATIONS FOR MAKING BEVERAGES (U.S. CLS. 45, 46 AND 48).

CLASS 33—WINES AND SPIRITS

FOR ALCOHOLIC BEVERAGES EXCEPT BEERS (U.S. CLS. 47 AND 49).
JILL C. ALT, EXAMINING ATTORNEY

SN 85-339,167. CONVATEC INC., SKILLMAN, NJ. FILED 6-6-2011.

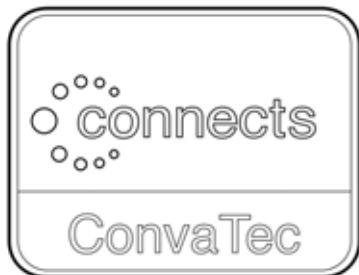

OWNER OF U.S. REG. NOS. 3,696,709 AND 3,901,205.
THE MARK CONSISTS OF THE DESIGN OF A SQUARE FEATURING AN UPPER SECTION INCLUDING A DESIGN OF MULTIPLE CIRCLES FORMING A LARGER CIRCLE AND INTERSECTING WITH THE WORD "CONNECTS", AND A LOWER SECTION INCLUDING THE WORD "CONVATEC".

CLASS 41—EDUCATION AND ENTERTAINMENT

FOR PROVIDING A LIVE FORUM IN THE NATURE OF WORKSHOPS FOR NURSES TO DISCUSS ISSUES RELATING TO THE CARE OF PATIENTS (U.S. CLS. 100, 101 AND 107).

CLASS 42—SCIENTIFIC AND COMPUTER SERVICES

FOR CREATING AN ONLINE COMMUNITY FOR REGISTERED USERS, NAMELY, NURSES, TO PARTICIPATE IN DISCUSSIONS, GET FEEDBACK FROM THEIR PEERS, FORM VIRTUAL COMMUNITIES, AND ENGAGE IN SOCIAL NETWORKING (U.S. CLS. 100 AND 101).

KEVIN DINALLO, EXAMINING ATTORNEY

SN 85-339,198. BRETTFORD MANUFACTURING, INC., FRANKLIN PARK, IL. FILED 6-6-2011.

EDU 2.0 LEARNING IS SOCIAL

THE MARK CONSISTS OF STANDARD CHARACTERS WITHOUT CLAIM TO ANY PARTICULAR FONT, STYLE, SIZE, OR COLOR.

NO CLAIM IS MADE TO THE EXCLUSIVE RIGHT TO USE "EDU", APART FROM THE MARK AS SHOWN.

CLASS 9—ELECTRICAL AND SCIENTIFIC APPARATUS

FOR MOBILE CARTS SPECIFICALLY ADAPTED FOR CHARGING AND SYNCHRONIZING ELECTRONIC DEVICES; MOBILE COMPUTERIZED INTERACTIVE WHITEBOARDS (U.S. CLS. 21, 23, 26, 36 AND 38).

CLASS 16—PAPER GOODS AND PRINTED MATTER

FOR MOBILE INTERACTIVE WHITEBOARDS IN THE NATURE OF DRY ERASE BOARDS (U.S. CLS. 2, 5, 22, 23, 29, 37, 38 AND 50).

CLASS 20—FURNITURE AND ARTICLES NOT OTHERWISE CLASSIFIED

FOR EDUCATIONAL FURNITURE, NAMELY MOBILE PRESENTATION LECTERNS; MOBILE INSTRUCTOR DESKS WITH SUPPORT FOR TECHNOLOGY; MOBILE TABLES FOR COMPUTERS AND STUDENT INTERACTION; MODULAR SOFT SEATING WITH POWER; CAFE TABLES; STUDENT CHAIRS AND CAFE CHAIRS (U.S. CLS. 2, 13, 22, 25, 32 AND 50).

JANICE L. MCMORROW, EXAMINING ATTORNEY

SN 85-339,589. BNP MEDIA II, LLC, TROY, MI. FILED 6-7-2011.



NO CLAIM IS MADE TO THE EXCLUSIVE RIGHT TO USE "VIRTUAL GREEN EXPO", APART FROM THE MARK AS SHOWN.

THE MARK CONSISTS OF THE WORD "VIRTUAL" DISPOSED HORIZONTALLY ON A FIRST LINE, THE WORD "GREEN" IN A STYLIZED FONT DISPOSED HORIZONTALLY ON A SECOND LINE BELOW THE FIRST LINE, AND WHEREIN THE WORDS "VIRTUAL" AND "GREEN" ARE SLIGHTLY OFFSET FROM EACH OTHER AND THE WORD "VIRTUAL" SLIGHTLY OVERLAPS THE TOP PORTION OF THE WORD "GREEN". THE MARK FURTHER CONSISTS OF THE WORD "EXPO" DISPOSED VERTICALLY AT THE END OF THE WORD "GREEN", AND AN ILLUSTRATION OF A GLOBE DISPOSED IN THE BACKGROUND BEHIND A PORTION OF THE WORD "GREEN".

CLASS 35—ADVERTISING AND BUSINESS

FOR ARRANGING AND CONDUCTING ONLINE TRADESHOW EXHIBITIONS IN THE FIELD OF SUSTAINABLE BUILDING (U.S. CLS. 100, 101 AND 102).

CLASS 41—EDUCATION AND ENTERTAINMENT

FOR EDUCATION SERVICES, NAMELY, PROVIDING ONLINE CONFERENCES AND WEBINARS IN THE FIELD OF SUSTAINABLE BUILDING (U.S. CLS. 100, 101 AND 107).

WILLIAM VERHOSEK, EXAMINING ATTORNEY

SN 85-341,704. AGRIAN INC., FRESNO, CA. FILED 6-8-2011.

AGRIAN AUTO DATA

THE MARK CONSISTS OF STANDARD CHARACTERS WITHOUT CLAIM TO ANY PARTICULAR FONT, STYLE, SIZE, OR COLOR.

OWNER OF U.S. REG. NOS. 3,714,405, 3,717,773 AND 3,730,741.

NO CLAIM IS MADE TO THE EXCLUSIVE RIGHT TO USE "AUTO" AND "DATA", APART FROM THE MARK AS SHOWN.

THE WORDING "AGRIAN" HAS NO MEANING IN A FOREIGN LANGUAGE.

CLASS 9—ELECTRICAL AND SCIENTIFIC APPARATUS

FOR COMPUTER SOFTWARE FOR TRACKING, MANAGEMENT AND ANALYSIS OF CHEMICAL AND FERTILIZER AND FIELD DATA IN THE FIELD OF AGRICULTURE (U.S. CLS. 21, 23, 26, 36 AND 38).

FIRST USE 5-18-2011; IN COMMERCE 5-18-2011.

CLASS 35—ADVERTISING AND BUSINESS

FOR COMMERCIAL INFORMATION IN THE FIELD OF TRACKING, LOCATING AND MONITORING THE GEOGRAPHIC LOCATION OF VEHICLES, MACHINERY, ELECTRONIC EQUIPMENT AND ASSETS IN THE FIELD OF AGRICULTURE (U.S. CLS. 100, 101 AND 102).

FIRST USE 5-18-2011; IN COMMERCE 5-18-2011.

CLASS 42—SCIENTIFIC AND COMPUTER SERVICES

FOR COMPUTER SERVICES, NAMELY, PROVIDING DATABASE SERVERS TO OTHERS FOR ELECTRONIC GATHERING, ANALYZING AND FORMATTING DATA TO TRACK, LOCATE, MONITOR AND LOG OPERATIONS FOR ANALYSIS OF ASSETS AND FIELD DATA IN THE FIELD OF AGRICULTURE SERVERS TO OTHERS (U.S. CLS. 100 AND 101).

FIRST USE 5-18-2011; IN COMMERCE 5-18-2011.

PAUL MORENO, EXAMINING ATTORNEY

SN 85-341,968. THREEJOY ASSOCIATES, INC., CHAMPAIGN, IL. FILED 6-9-2011.

THREEJOY

THE MARK CONSISTS OF STANDARD CHARACTERS WITHOUT CLAIM TO ANY PARTICULAR FONT, STYLE, SIZE, OR COLOR.

CLASS 35—ADVERTISING AND BUSINESS

FOR BUSINESS CONSULTING IN THE FIELD OF ORGANIZATIONAL, CONCEPTUAL AND MOTIVATIONAL CHANGE DESIGN, PLANNING, IMPLEMENTATION AND MANAGEMENT (U.S. CLS. 100, 101 AND 102).

FIRST USE 8-11-2010; IN COMMERCE 8-11-2010.

CLASS 41—EDUCATION AND ENTERTAINMENT

FOR EDUCATIONAL SERVICES, NAMELY, CLASSES, SEMINARS AND WORKSHOPS IN THE FIELD OF ORGANIZATIONAL, CONCEPTUAL AND MOTIVATIONAL CHANGE DESIGN, PLANNING, IMPLEMENTATION AND MANAGEMENT; LEADERSHIP AND EXECUTIVE COACHING; BUSINESS TRAINING IN THE NATURE OF STAFF TRAINING AND DEVELOPMENT; STUDENT PROGRAM ASSESSMENT CLASSES AND PROGRAMS VIA CLASSROOM INSTRUCTION AND VIA A GLOBAL COMMUNICATIONS NETWORK; CURRICULUM PLANNING AND DEVELOPMENT FOR EDUCATORS (U.S. CLS. 100, 101 AND 107).

FIRST USE 8-11-2010; IN COMMERCE 8-11-2010.

BRIAN CALLAGHAN, EXAMINING ATTORNEY

SN 85-341,988. THREEJOY ASSOCIATES, INC., CHAMPAIGN, IL. FILED 6-9-2011.



THE MARK CONSISTS OF THREE FISH SWIMMING.

CLASS 35—ADVERTISING AND BUSINESS

FOR BUSINESS CONSULTING IN THE FIELD OF ORGANIZATIONAL, CONCEPTUAL AND MOTIVATIONAL CHANGE DESIGN, PLANNING, IMPLEMENTATION AND MANAGEMENT (U.S. CLS. 100, 101 AND 102).

FIRST USE 8-11-2010; IN COMMERCE 8-11-2010.

CLASS 41—EDUCATION AND ENTERTAINMENT

FOR EDUCATIONAL SERVICES, NAMELY, CLASSES, SEMINARS AND WORKSHOPS IN THE FIELD OF ORGANIZATIONAL, CONCEPTUAL AND MOTIVATIONAL CHANGE DESIGN, PLANNING, IMPLEMENTATION AND MANAGEMENT; LEADERSHIP AND EXECUTIVE COACHING; BUSINESS TRAINING IN THE NATURE OF STAFF TRAINING AND DEVELOPMENT; STUDENT PROGRAM ASSESSMENT CLASSES AND PROGRAMS VIA CLASSROOM INSTRUCTION AND VIA A GLOBAL COMMUNICATIONS NETWORK; CURRICULUM PLANNING AND DEVELOPMENT FOR EDUCATORS (U.S. CLS. 100, 101 AND 107).

FIRST USE 8-11-2010; IN COMMERCE 8-11-2010.

BRIAN CALLAGHAN, EXAMINING ATTORNEY

SN 85-342,426. KEELER LIMITED, WINDSOR, BERKSHIRE, UNITED KINGDOM, FILED 6-9-2011.

KAT

THE MARK CONSISTS OF STANDARD CHARACTERS WITHOUT CLAIM TO ANY PARTICULAR FONT, STYLE, SIZE, OR COLOR.

PRIORITY CLAIMED UNDER SEC. 44(D) ON UNITED KINGDOM APPLICATION NO. 2579962, FILED 5-3-2011, REG. NO. 2579962, DATED 5-3-2011, EXPIRES 5-3-2021.

CLASS 9—ELECTRICAL AND SCIENTIFIC APPARATUS

FOR OPTICAL LENSES; OPTICAL TONOMETERS FOR LABORATORY USE; CASES ADAPTED FOR CARRYING THE AFORESAID GOODS; PARTS AND FITTINGS FOR ALL THE AFORESAID GOODS (U.S. CLS. 21, 23, 26, 36 AND 38).

CLASS 10—MEDICAL APPARATUS

FOR TONOMETERS; TONOMETER PRISMS; APPLICATION TONOMETERS; PARTS AND FITTINGS FOR ALL THE AFORESAID GOODS (U.S. CLS. 26, 39 AND 44).
FLORENTINA BLANDU, EXAMINING ATTORNEY

SN 85-342,444. WIND OPERATIONS WORLDWIDE S.P.A., MILANO (MI), ITALY, FILED 6-9-2011.



PRIORITY CLAIMED UNDER SEC. 44(D) ON ERP N CMNTY TM OFC APPLICATION NO. 009945759, FILED 5-6-2011, REG. NO. 9945759, DATED 10-13-2011, EXPIRES 5-6-2021.

THE COLOR(S) LIGHT BLUE, ORANGE AND RED IS/ ARE CLAIMED AS A FEATURE OF THE MARK.

THE MARK CONSISTS OF THE WORD "WOW" IN CAPITAL LETTERS; THE TWO LETTERS "W" APPEARING IN THE MARK ARE LIGHT BLUE AND THE LETTER "O" IS FORMED BY TWO STYLIZED CRESCENTS THAT ARE FACING EACH OTHER, ONE IN ORANGE AND ONE IN RED.

CLASS 35—ADVERTISING AND BUSINESS

FOR CONSULTANCY IN THE FIELD OF ENERGY ECONOMICS, NAMELY, CONSULTING SERVICES IN THE FIELD OF ENERGY USAGE MANAGEMENT AND ENERGY EFFICIENCY (U.S. CLS. 100, 101 AND 102).

CLASS 36—INSURANCE AND FINANCIAL

FOR FINANCIAL CONSULTANCY IN THE FIELD OF ENERGY; CONSULTANCY IN THE FIELD OF ENERGY ECONOMICS, NAMELY, CONSULTING RELATING TO THE FINANCING OF ENERGY PROJECTS AND ENERGY PRODUCTS (U.S. CLS. 100, 101 AND 102).

CLASS 39—TRANSPORTATION AND STORAGE

FOR SUPPLY AND DISTRIBUTION OF ELECTRICAL ENERGY (U.S. CLS. 100 AND 105).

CLASS 40—MATERIAL TREATMENT

FOR ENERGY PRODUCTION (U.S. CLS. 100, 103 AND 106).

CLASS 42—SCIENTIFIC AND COMPUTER SERVICES

FOR ENGINEERING SERVICES IN THE FIELD OF ELECTRICAL ENERGY AND NATURAL GAS PRODUCTION (U.S. CLS. 100 AND 101).

MICHAEL KEATING, EXAMINING ATTORNEY

SN 85-343,312. EHAPPYLIFE, LLC, DBA VIZMARKET, BONITA SPRINGS, FL. FILED 6-10-2011.

VIZMARKET

THE MARK CONSISTS OF STANDARD CHARACTERS WITHOUT CLAIM TO ANY PARTICULAR FONT, STYLE, SIZE, OR COLOR.

CLASS 35—ADVERTISING AND BUSINESS

FOR PROVIDING AN ON-LINE SEARCHABLE DATABASE FEATURING INFORMATION IN BUSINESS MATTERS REGARDING COMMERCIAL AND NON-COMMERCIAL BUSINESSES AND PROFESSIONALS; PROMOTIONAL MARKETING SERVICES USING AUDIOVISUAL MEDIA, AND ONLINE ADVERTISING AND MARKETING SERVICES (U.S. CLS. 100, 101 AND 102).

CLASS 41—EDUCATION AND ENTERTAINMENT

FOR MUSIC COMPOSITION AND PRODUCTION SERVICES (U.S. CLS. 100, 101 AND 107).

DEIRDRE ROBERTSON, EXAMINING ATTORNEY

SN 85-343,341. WILLSON, LAURA, SPOKANE, WA. FILED 6-10-2011.

PEACOCK VIRTUAL SOLUTIONS

THE MARK CONSISTS OF STANDARD CHARACTERS WITHOUT CLAIM TO ANY PARTICULAR FONT, STYLE, SIZE, OR COLOR.

NO CLAIM IS MADE TO THE EXCLUSIVE RIGHT TO USE "VIRTUAL SOLUTIONS", APART FROM THE MARK AS SHOWN.

CLASS 35—ADVERTISING AND BUSINESS

FOR PROVIDING VIRTUAL ON-LINE OFFICE SUPPORT STAFF SERVICES FOR BUSINESSES AND INDIVIDUALS IN HOME OFFICES AND IN BUSINESS OFFICES, NAMELY, CONSULTANCY AND ADVISORY SERVICES IN THE FIELDS OF DEVELOPMENT OF BUSINESS PLANS AND ADVERTISING CAMPAIGNS TO ACHIEVE BUSINESS GOALS, DEVELOPMENT OF BUSINESS STRATEGIES, AND ASSISTING OTHERS WITH THE DEVELOPMENT OF MARKETING STRATEGIES; BUSINESS CONSULTANCY SERVICES, NAMELY, ASSISTING BUSINESSES WITH THE DEVELOPMENT OF CREATIVE BUSINESS IDEAS; MEDIA MONITORING SERVICES, NAMELY, PROVIDING ANALYSIS OF MEDIA CONTENT FOR BUSINESS PURPOSES ON CUSTOMER SPECIFIED TOPICS OF SOCIAL MEDIA; SPECIAL EVENT PLANNING FOR BUSINESS PURPOSES; SECRETARIAL AND CLERICAL SERVICES, NAMELY, BUDGETING, BOOKKEEPING, PREPARATION AND FILING OF CLAIMS, PREPARATION AND FILING OF FORMS, BILL PAYING, ORGANIZING AND PROCESSING PAPERWORK, APPOINTMENT SCHEDULING SERVICES, ANSWERING TELEPHONES, CHECKING MESSAGES, MAIL SORTING, MAIL HANDLING AND MAIL RECEIVING (U.S. CLS. 100, 101 AND 102).

FIRST USE 6-22-2004; IN COMMERCE 6-22-2004.

CLASS 42—SCIENTIFIC AND COMPUTER SERVICES

FOR CREATION, DESIGN, DEVELOPMENT AND MAINTENANCE OF WEB SITES FOR THIRD PARTIES; TECHNICAL SUPPORT SERVICES, NAMELY, TROUBLESHOOTING OF DATA BASES AND SPREAD-SHEET APPLICATIONS; SOCIAL MEDIA MANAGEMENT, NAMELY, ASSISTING OTHERS IN CREATING AND UPLOADING ITEMS TO SOCIAL WEBSITES (U.S. CLS. 100 AND 101).

FIRST USE 6-22-2004; IN COMMERCE 6-22-2004.
JACLYN KIDWELL WALKER, EXAMINING ATTORNEY

CLASS 9—ELECTRICAL AND SCIENTIFIC APPARATUS

FOR PRE-RECORDED DVDS, CDS, VIDEO DISCS, VIDEO TAPES, DOWNLOADABLE VIDEO PROVIDED VIA STREAMING VIDEO IN THE FIELD OF BOXING, SOCCER, BASEBALL AND OTHER SPORTS; DOWNLOADABLE ELECTRONIC PUBLICATIONS, NAMELY, MAGAZINES, IN THE FIELD OF BOXING, SOCCER, BASEBALL AND OTHER SPORTS; COMPUTER GAME SOFTWARE FOR PERSONAL COMPUTERS AND VIDEO GAME CONSOLES FEATURING BOXING, SOCCER, BASEBALL AND OTHER SPORTS (U.S. CLS. 21, 23, 26, 36 AND 38).

CLASS 25—CLOTHING

FOR WEARING APPAREL, NAMELY, WARM-UP SUITS, SWEATSHIRTS, TEE-SHIRTS; MUSCLE SHIRTS; SPORTS SHIRTS; TANK TOPS; BATHING SUITS; BEACH WEAR; JOGGING SUITS; SHORTS; SHIRTS; GLOVES; UNDERWEAR; JERSEYS; HEADWEAR; FOOTWEAR, BELTS, SOCKS, HATS; CAPS; ATHLETIC WEAR, PERFORMANCE ATHLETIC WEAR, WORKOUT AND SPORTS APPAREL, NAMELY, SHORTS AND SHIRTS (U.S. CLS. 22 AND 39).

SN 85-343,536. BABY BULL, LLC, HOUSTON, TX. FILED 6-10-2011.



THE COLOR(S) BLUE, SPECIFICALLY PANTONE 300M BLUE IS/ARE CLAIMED AS A FEATURE OF THE MARK.

THE MARK CONSISTS OF THE HEAD, ARCHED NECK AND HORNS OF A BULL, WITH THE HEAD AND NECK DONE IN AN OUTLINE STYLE WITH THE OUTLINE, FEATURES AND FOLDS OF SKIN IN BLUE, SPECIFICALLY PANTONE 300M BLUE AND THE HORNS DONE PRIMARILY IN SOLID BLUE, SPECIFICALLY PANTONE 300M BLUE WITH A STREAK OF NEGATIVE SPACE RUNNING UP THE LENGTH OF THE HORN.

CLASS 41—EDUCATION AND ENTERTAINMENT

FOR ENTERTAINMENT, NAMELY, A CONTINUING PROGRAM FEATURING NEWS, SPORTS, TALK AND INTERVIEWS ABOUT SPORTS DELIVERED BY TELEVISION, RADIO, SATELLITE AND A GLOBAL COMMUNICATIONS NETWORK; PRODUCTION OF A CONTINUOUS AUDIO OR VIDEO PROGRAM TO BROADCAST OVER TELEVISION, RADIO, SATELLITE, AND VIA A GLOBAL COMMUNICATIONS NETWORK; ATHLETIC TRAINING SERVICES; INSTRUCTION IN THE FIELD OF BOXING, SOCCER, BASEBALL AND OTHER SPORTS; PERSONAL COACHING SERVICES IN THE FIELD OF BOXING, SOCCER, BASEBALL AND OTHER SPORTS; PHYSICAL FITNESS TRAINING SERVICES; SPORTS TRAINING SERVICES; TRAINING SERVICES IN THE FIELD OF BOXING, SOCCER, BASEBALL AND OTHER SPORTS; SPORT CAMPS; ENTERTAINMENT SERVICES, NAMELY, ORGANIZING AND PROMOTING BOXING, FIGHTING, SOCCER, BASEBALL, AND OTHER SPORT EVENTS; AND PRODUCTION AND DISTRIBUTION OF BOXING, SOCCER, BASEBALL AND OTHER SPORTS EXHIBITIONS FOR TELEVISION, RADIO, AND ONLINE BROADCASTS; ENTERTAINMENT SERVICES, NAMELY, PERSONAL APPEARANCES BY A CELEBRITY AND SPORTS STAR; ENTERTAINMENT SERVICES, NAMELY, PRODUCTION OF RECORDED DVDS, CDS, VIDEO DISCS, VIDEO TAPES, DOWNLOADABLE VIDEO, AND STREAMING VIDEO IN THE FIELD OF BOXING, SOCCER, BASEBALL AND OTHER SPORTS; PUBLISHING OF DOWNLOADABLE ELECTRONIC PUBLICATIONS; PRODUCTION OF COMPUTER GAME SOFTWARE FOR PERSONAL COMPUTERS AND VIDEO GAME CONSOLES FEATURING BOXING, SOCCER, BASEBALL AND OTHER SPORTS (U.S. CLS. 100, 101 AND 107).

PAM WILLIS, EXAMINING ATTORNEY

SN 85-344,838. BROWN & YELLOW INTERNATIONAL HOLDINGS LLC, NEW YORK, NY. FILED 6-13-2011.

SN 85-344,933. AIR FORCE HERITAGE FLIGHT FOUNDATION, HOUSTON, TX. FILED 6-13-2011.

AIR FORCE HERITAGE FLIGHT FOUNDATION



THE COLOR(S) YELLOW, BROWN, WHITE, BLACK, GRAY AND ORANGE IS/ARE CLAIMED AS A FEATURE OF THE MARK.

THE MARK CONSISTS OF A CHARACTER WITH A YELLOW BODY OUTLINED IN ORANGE, A CHARACTER WITH A BROWN BODY OUTLINED IN BLACK, SIDE BY SIDE, WITH THE WORDS "PEE & POO SAVE THE WORLD!" BELOW THEIR FIGURES, "PEE" AND "POO" AND "SAVE THE WORLD!" IN WHITE OUTLINED IN BROWN AND SURROUNDED BY A GRAY CLOUD, AND THE "&" SYMBOL IN ORANGE.

CLASS 9—ELECTRICAL AND SCIENTIFIC APPARATUS

FOR COMPUTER GAME PROGRAMMES DOWNLOADABLE VIA THE INTERNET; COMPUTER GAME SOFTWARE; COMPUTER GAME SOFTWARE FOR USE WITH PERSONAL COMPUTERS, HOME VIDEO GAME CONSOLES USED WITH TELEVISIONS AND ARCADE-BASED VIDEO GAME CONSOLES; COMPUTER SOFTWARE AND FIRMWARE FOR GAMES OF CHANCE ON ANY COMPUTERIZED PLATFORM, INCLUDING DEDICATED GAMING CONSOLES, VIDEO BASED SLOT MACHINES, REEL BASED SLOT MACHINES, AND VIDEO LOTTERY TERMINALS; COMPUTER SOFTWARE, NAMELY, GAME ENGINE SOFTWARE FOR VIDEO GAME DEVELOPMENT AND OPERATION; DOWNLOADABLE COMPUTER GAME PROGRAMS; DOWNLOADABLE ELECTRONIC GAME PROGRAMS; DOWNLOADABLE MULTIMEDIA FILE CONTAINING ARTWORK, TEXT, AUDIO, VIDEO, GAMES, AND INTERNET WEB LINKS RELATING TO VARIOUS ANIMATED CHARACTERS (U.S. CLS. 21, 23, 26, 36 AND 38).

CLASS 42—SCIENTIFIC AND COMPUTER SERVICES

FOR DESIGNING AND DEVELOPING COMPUTER GAME SOFTWARE AND VIDEO GAME SOFTWARE FOR USE WITH COMPUTERS, VIDEO GAME PROGRAM SYSTEMS AND COMPUTER NETWORKS (U.S. CLS. 100 AND 101).

MARTHA SANTOMARTINO, EXAMINING ATTORNEY

THE MARK CONSISTS OF STANDARD CHARACTERS WITHOUT CLAIM TO ANY PARTICULAR FONT, STYLE, SIZE, OR COLOR.

NO CLAIM IS MADE TO THE EXCLUSIVE RIGHT TO USE "AIR FORCE" AND "FOUNDATION", APART FROM THE MARK AS SHOWN.

CLASS 25—CLOTHING

FOR ARTICLES OF CLOTHING, NAMELY, SHIRTS, COATS, JACKETS, TROUSERS, SWEATSHIRTS; JEANS; T-SHIRTS, VESTS, SHORTS; UNDERWEAR; SLEEPWEAR; SKIRTS; BLOUSES; OVERCOATS; RAINWEAR; WATERPROOF CLOTHING IN THE NATURE OF RAINCOATS, PONCHOS, AND WATERPROOF TROUSERS; SWEATERS; PULLOVERS; CARDIGANS; TIES; BELTS; SCARVES; SPORTS CLOTHING, NAMELY, RUNNING GEAR IN THE NATURE OF RUNNING SHOES, RUNNING JACKETS, RUNNING PANTS, AND RUNNING VESTS; ATHLETIC WEAR IN THE NATURE OF ARTICLES OF FOOTWEAR FOR ATHLETICS, NAMELY, ATHLETICS SOCKS, ATHLETICS SHOES, ATHLETICS SHOES FOR BASKETBALL, ATHLETICS SHORTS, AND ATHLETICS VESTS; EXERCISE WEAR IN THE NATURE OF EXERCISE PANTS, EXERCISE SHIRTS, TOPS FOR USE IN EXERCISE, AND JERSEYS; FOOTWEAR; SHOES; BOOTS; BOOTS FOR SPORTS; CAPS; HATS; HEADGEAR, NAMELY, BASEBALL CAPS; BODY SUITS; SOCKS; GLOVES; AIR CREW FLIGHT SUITS WITH BOOTS; GLOVES (U.S. CLS. 22 AND 39).

CLASS 35—ADVERTISING AND BUSINESS

FOR PROMOTING PUBLIC INTEREST IN AIRCRAFT, AIR SHOWS, AIRCRAFT EXHIBITIONS AND AERIAL DEMONSTRATIONS; PROMOTING PUBLIC INTEREST IN HISTORICAL MILITARY AIRCRAFT; RETAIL STORE SERVICES AND ONLINE RETAIL STORE SERVICES FEATURING AIRCRAFT MEMORABILIA AND SOUVENIRS (U.S. CLS. 100, 101 AND 102).

CLASS 41—EDUCATION AND ENTERTAINMENT

FOR ENTERTAINMENT AND EDUCATIONAL SERVICES, NAMELY, ORGANIZING AND PROVIDING AIR SHOWS, AIRCRAFT EXHIBITIONS AND AERIAL DEMONSTRATIONS; ENTERTAINMENT AND EDUCATIONAL SERVICES, NAMELY, MAINTAINING A MUSEUM FEATURING HISTORICAL MILITARY AIRCRAFT AND PRESERVING AND DISPLAYING SUCH AIRCRAFT (U.S. CLS. 100, 101 AND 107).

BARBARA BROWN, EXAMINING ATTORNEY

SN 85-345,063. GREASY COMB, LLC, LA HABRA, CA. FILED 6-13-2011.

Fiction BMX

THE MARK CONSISTS OF STANDARD CHARACTERS WITHOUT CLAIM TO ANY PARTICULAR FONT, STYLE, SIZE, OR COLOR.

NO CLAIM IS MADE TO THE EXCLUSIVE RIGHT TO USE "BMX", APART FROM THE MARK AS SHOWN.

CLASS 12—VEHICLES

FOR BICYCLES; BICYCLE PARTS, NAMELY, FRAME, FORK, HEADSETS THAT PROVIDE A ROTATABLE INTERFACE BETWEEN THE BICYCLE FORK AND THE BICYCLE FRAME; BICYCLE PARTS, NAMELY, HANDLEBARS; BICYCLE PARTS, NAMELY, HANDLE BAR ENDS; BICYCLE PARTS, NAMELY, HANDLE BAR STEMS; BICYCLE BRAKES; BICYCLE PARTS, NAMELY, BRAKE LEVERS AND BRAKE WIRE SOLD AS INTEGRAL COMPONENT PARTS OF BICYCLE BRAKES; BICYCLE PARTS, NAMELY, BOTTOM BRACKETS THAT PROVIDE A ROTATABLE INTERFACE BETWEEN THE BICYCLE FRAME AND THE BICYCLE CRANKS; BICYCLE PARTS, NAMELY, CRANKS WHICH ARE SOLD AS INTEGRAL COMPONENTS OF BICYCLES AND LEVERAGE THE PROPULSION MECHANISM TO ENABLE ROTATION OF THE DRIVE-TRAIN; BICYCLE CHAINS; BICYCLE PARTS, NAMELY, PEGS SOLD AS INTEGRAL COMPONENTS OF BICYCLES, WHICH FASTEN TO THE AXLE OF BICYCLE WHEELS; BICYCLE PARTS, NAMELY, HUBS THAT PROVIDE A POINT OF ROTATION FOR BICYCLE WHEELS; BICYCLE WHEEL RIMS; BICYCLE PARTS, NAMELY, RIM STRIPS IN THE NATURE OF A BARRIER BETWEEN THE NIPPLES THAT PROTRUDE FROM THE BICYCLE WHEEL RIM AND THE BICYCLE INNER TUBE; BICYCLE TIRES; INNER TUBES FOR BICYCLES; BICYCLE SADDLES; BICYCLE PARTS, NAMELY, SEAT CLAMPS SOLD AS INTEGRAL COMPONENTS OF BICYCLE FRAMES, WHICH IMPEDE THE MOVEMENT OF THE SEAT POST; BICYCLE PARTS, NAMELY, BRAKE WIRE DETANGLERS SOLD AS AN INTEGRAL COMPONENTS OF BICYCLES AND, SPECIFICALLY, ARE PARTS OF HEAD SET SYSTEMS THAT ALLOW THE ROTATION OF BICYCLE HANDLEBARS, FORKS, AND FRONT WHEELS WITHOUT INTERFERING WITH BICYCLE BRAKING SYSTEMS (U.S. CLS. 19, 21, 23, 31, 35 AND 44).

CLASS 25—CLOTHING

FOR CLOTHING, NAMELY, SWEATSHIRTS, SHIRTS, SOCKS AND HATS (U.S. CLS. 22 AND 39).
 MAUREEN DALL, EXAMINING ATTORNEY

SN 85-345,348. D'ARCO, DANIEL, POTTSVILLE, PA. FILED 6-14-2011.



THE COLOR(S) BLACK, BLUE, PURPLE, GREEN AND GRAY IS/ARE CLAIMED AS A FEATURE OF THE MARK. THE MARK CONSISTS OF A GLOBE HAVING CONTI-

NENTS RENDERED IN GREEN AND GRAY, AND WATER RENDERED IN BLUE AND GRAY; A PURPLE GEM SITS AT THE TOP OF THE GLOBE, FLANKED BY A REPRESENTATION OF A PYRAMID ON ONE SIDE AND A CATHEDRAL ON THE OTHER SIDE, BOTH RENDERED IN PURPLE AND BLACK; THE LITERAL ELEMENT "TOOM", IS RENDERED IN A GRAY, STYLIZED, ARCHED FONT NEAR THE TOP OF THE MARK, AGAINST A BLACK BACKGROUND; BETWEEN THE LITERAL ELEMENT AND THE GLOBE IS A SHIMMERING PURPLE AREA.

CLASS 25—CLOTHING

FOR CAPS, HATS, HEAD WEAR, SHORTS, T-SHIRTS, SLEEPWEAR, SWEATPANTS, TIES, UNDERWEAR, SHOES (U.S. CLS. 22 AND 39).

CLASS 41—EDUCATION AND ENTERTAINMENT

FOR ENTERTAINMENT SERVICES, NAMELY, PRODUCTION AND DISTRIBUTION OF MOTION PICTURES; SCRIPT DEVELOPMENT, NAMELY, SCRIPTWRITING SERVICES; ENTERTAINMENT INFORMATION, NAMELY, PROVIDING ONLINE NEWS AND INFORMATION RELATED TO MOTION PICTURES, SCIENCE FICTION TOPICS AND COMPUTER GAMING; CONSULTING IN THE FIELD OF MOTION PICTURE PRODUCTION (U.S. CLS. 100, 101 AND 107).
 SANI KHOURI, EXAMINING ATTORNEY

SN 85-345,908. HMSHOST CORPORATION, BETHESDA, MD. FILED 6-14-2011.



NO CLAIM IS MADE TO THE EXCLUSIVE RIGHT TO USE "BAKERY & CAFE", APART FROM THE MARK AS SHOWN.

THE COLOR(S) GREEN, BLACK, AND GRAY IS/ARE CLAIMED AS A FEATURE OF THE MARK.

THE MARK CONSISTS OF AN IMAGE OF A GREEN PEAR WITH GRAY SHADING AND A GRAY AND BLACK LEAF HANGING FROM A GRAY AND BLACK TWIG. THE BLACK WORDING "DÉLICE MAISON" APPEARS BENEATH THE IMAGE AND THE BLACK WORDING "BAKERY & CAFE" APPEARS BENEATH THE WORDING "DÉLICE MAISON".

THE ENGLISH TRANSLATION OF "DÉLICE MAISON" IN THE MARK IS "DELICIOUS HOUSE".

CLASS 35—ADVERTISING AND BUSINESS

FOR RETAIL BAKERY SHOPS (U.S. CLS. 100, 101 AND 102).

CLASS 43—HOTEL AND RESTAURANT SERVICES

FOR RESTAURANT SERVICES; CAFE SERVICES (U.S. CLS. 100 AND 101).
 KIM MONINGHOFF, EXAMINING ATTORNEY

SN 85-346,985. MERCK SHARP & DOHME CORP., WHITEHOUSE STATION, NJ. FILED 6-15-2011.

MERCK

THE MARK CONSISTS OF STANDARD CHARACTERS WITHOUT CLAIM TO ANY PARTICULAR FONT, STYLE, SIZE, OR COLOR.

OWNER OF U.S. REG. NOS. 108,566, 2,874,178 AND OTHERS.
SEC. 2(F).

CLASS 5—PHARMACEUTICALS

FOR MEDICATED SUPPLEMENTS FOR FOODSTUFFS FOR ANIMALS (U.S. CLS. 6, 18, 44, 46, 51 AND 52).

CLASS 10—MEDICAL APPARATUS

FOR MEDICAL X-RAY APPARATUS FOR USE IN AUTHENTICATING EQUINE IDENTIFICATION INFORMATION VIA A GLOBAL COMPUTER NETWORK (U.S. CLS. 26, 39 AND 44).

CLASS 35—ADVERTISING AND BUSINESS

FOR OPERATION OF TELEPHONE CALL CENTERS FOR VETERINARIANS, PROVIDING MEDICAL REFERRAL SERVICES IN THE NATURE OF ON-CALL VETERINARY PROFESSIONALS WHO REFER PET OWNERS TO EMERGENCY VETERINARIANS AND CLINICS (U.S. CLS. 100, 101 AND 102).

CLASS 41—EDUCATION AND ENTERTAINMENT

FOR PROVIDING ON-LINE ARTICLES AND NEWSLETTERS FOR VETERINARY PROFESSIONALS AND PET OWNERS VIA A GLOBAL COMPUTER NETWORK (U.S. CLS. 100, 101 AND 107).

CLASS 44—MEDICAL, BEAUTY AND AGRICULTURAL SERVICES

FOR HEALTHCARE SERVICES, NAMELY, HEALTH MANAGEMENT PROGRAM FOR EQUINE, PROVIDING A DATABASE IN THE FIELD OF EQUINE HEALTH MANAGEMENT FEATURING INPUTTING AND COLLECTION OF DATA AND INFORMATION ALL FOR EQUINE TREATMENT AND DIAGNOSTIC PURPOSES OFFERED VIA A GLOBAL COMPUTER NETWORK (U.S. CLS. 100 AND 101).

JENNIFER WILLISTON, EXAMINING ATTORNEY

SN 85-348,007. TORAY KABUSHIKI KAISHA (TORAY INDUSTRIES, INC.), TOKYO, JAPAN, FILED 6-16-2011.

TAFOP

THE MARK CONSISTS OF STANDARD CHARACTERS WITHOUT CLAIM TO ANY PARTICULAR FONT, STYLE, SIZE, OR COLOR.

PRIORITY CLAIMED UNDER SEC. 44(D) ON JAPAN APPLICATION NO. 2011-041291, FILED 6-15-2011, REG. NO. 5458373, DATED 12-16-2011, EXPIRES 12-16-2021.

CLASS 1—CHEMICALS

FOR ADHESIVES AND GLUES FOR INDUSTRIAL USE (U.S. CLS. 1, 5, 6, 10, 26 AND 46).

CLASS 17—RUBBER GOODS

FOR ADHESIVE TAPES FOR USE IN PROCESSING SEMICONDUCTORS (U.S. CLS. 1, 5, 12, 13, 35 AND 50).
KATHERINE CHANG, EXAMINING ATTORNEY

SN 85-348,419. COMPLIANCE IMPLEMENTATION SERVICES, AKA CIS, MEDIA, PA. FILED 6-16-2011.

CalcPartner

THE MARK CONSISTS OF A NON-COLOR/BLACK AND/OR WHITE VERSION OF THE NAME "CALCPARTNER". THE "C" AND "P" ARE BOTH CAPITALIZED, WHILE THE REST OF THE LETTERS ARE LOWERCASED.

CLASS 9—ELECTRICAL AND SCIENTIFIC APPARATUS

FOR COMPUTER SOFTWARE FOR PERFORMING GOVERNMENT PRICING CALCULATIONS IN THE PHARMACEUTICAL INDUSTRY FOR USE BY GOVERNMENT SUBSIDIZED DRUG PROGRAM ANALYSTS; COMPUTER SOFTWARE FOR PRESERVING AND INDEXING GOVERNMENT PRICING CALCULATIONS IN THE PHARMACEUTICAL INDUSTRY FOR USE BY GOVERNMENT SUBSIDIZED DRUG PROGRAM ANALYSTS; COMPUTER DATABASE SOFTWARE FOR USE IN THE PHARMACEUTICAL INDUSTRY TO MAINTAIN TEN-YEAR HISTORIES OF DATA, LOGIC, AUDITS, AND PRICING RUNS; COMPUTER SOFTWARE FOR GENERATING REPORTS, VIEWING, SORTING, AND FILTERING CALCULATIONS IN THE PHARMACEUTICAL INDUSTRY FOR USE BY GOVERNMENT SUBSIDIZED DRUG PROGRAM ANALYSTS; COMPUTER SOFTWARE FOR CONDUCTING AND PRESERVING PRICING CALCULATIONS RELATED TO THE GOVERNMENT SUBSIDIZED DRUG PROGRAMS FOR USE IN THE PHARMACEUTICAL INDUSTRY BY GOVERNMENT SUBSIDIZED DRUG PROGRAM ANALYSTS (U.S. CLS. 21, 23, 26, 36 AND 38).
FIRST USE 9-11-2007; IN COMMERCE 10-1-2008.

CLASS 42—SCIENTIFIC AND COMPUTER SERVICES

FOR PROVIDING TEMPORARY USE OF ON-LINE NON-DOWNLOADABLE SOFTWARE FOR PERFORMING GOVERNMENT PRICING CALCULATIONS IN THE PHARMACEUTICAL INDUSTRY FOR USE BY GOVERNMENT SUBSIDIZED DRUG PROGRAM ANALYSTS; PROVIDING TEMPORARY USE OF ON-LINE NON-DOWNLOADABLE SOFTWARE FOR PRESERVING AND INDEXING GOVERNMENT PRICING CALCULATIONS IN THE PHARMACEUTICAL INDUSTRY FOR USE BY GOVERNMENT SUBSIDIZED DRUG PROGRAM ANALYSTS; PROVIDING TEMPORARY USE OF ON-LINE NON-DOWNLOADABLE DATABASE SOFTWARE FOR USE IN THE PHARMACEUTICAL INDUSTRY TO MAINTAIN TEN-YEAR HISTORIES OF DATA, LOGIC, AUDITS, AND PRICING RUNS; PROVIDING TEMPORARY USE OF ON-LINE NON-DOWNLOADABLE SOFTWARE FOR GENERATING REPORTS, VIEWING, SORTING, AND FILTERING CALCULATIONS IN THE PHARMACEUTICAL INDUSTRY FOR USE BY GOVERNMENT SUBSIDIZED DRUG PROGRAM ANALYSTS; PROVIDING TEMPORARY USE OF ON-LINE NON-DOWNLOADABLE SOFTWARE FOR CONDUCTING AND PRESERVING PRICING CALCULATIONS RELATED TO THE GOVERNMENT SUBSIDIZED DRUG PROGRAMS FOR USE IN THE PHARMACEUTICAL INDUSTRY BY GOVERNMENT SUBSIDIZED DRUG PROGRAM ANALYSTS (U.S. CLS. 100 AND 101).

FIRST USE 9-11-2007; IN COMMERCE 10-1-2008.
MARK SHINER, EXAMINING ATTORNEY

SN 85-348,973. UNIQUE SOLUTIONS DESIGN, LTD., DARTMOUTH, NOVA SCOTIA, CANADA, FILED 6-17-2011.

UNIQUE SOLUTIONS

THE MARK CONSISTS OF STANDARD CHARACTERS WITHOUT CLAIM TO ANY PARTICULAR FONT, STYLE, SIZE, OR COLOR.

CLASS 9—ELECTRICAL AND SCIENTIFIC APPARATUS

FOR MEASURABLE DATA SCANNERS FOR MERCHANDISING, VIRTUAL FITTING, BIOMEASUREMENT, FITNESS AND HEALTH (U.S. CLS. 21, 23, 26, 36 AND 38).

FIRST USE 4-28-2003; IN COMMERCE 4-28-2003.

CLASS 42—SCIENTIFIC AND COMPUTER SERVICES

FOR APPLICATION SERVICE PROVIDER (ASP), FEATURING SOFTWARE FOR USE IN PROVIDING RECOMMENDATIONS BASED ON MEASURABLE DATA IN THE FIELDS OF MERCHANDISING, VIRTUAL FITTING, BIOMEASUREMENT, FITNESS AND HEALTH (U.S. CLS. 100 AND 101).

FIRST USE 4-28-2003; IN COMMERCE 4-28-2003.
PAM WILLIS, EXAMINING ATTORNEY

SN 85-349,148. UNITEDHEALTH GROUP INCORPORATED, MINNETONKA, MN. FILED 6-17-2011.

UNITEDHEALTHCARE
RXSUPPLEMENT

THE MARK CONSISTS OF STANDARD CHARACTERS WITHOUT CLAIM TO ANY PARTICULAR FONT, STYLE, SIZE, OR COLOR.

OWNER OF U.S. REG. NOS. 1,967,622, 3,861,423 AND OTHERS.

NO CLAIM IS MADE TO THE EXCLUSIVE RIGHT TO USE "RXSUPPLEMENT", APART FROM THE MARK AS SHOWN.

CLASS 35—ADVERTISING AND BUSINESS

FOR ADMINISTRATION OF PHARMACY REIMBURSEMENT PROGRAMS AND SERVICES; HEALTH CARE COST MANAGEMENT SERVICES FOR PHARMACY BENEFIT AND PRESCRIPTION DRUG BENEFIT PLANS OF OTHERS; DRUG UTILIZATION REVIEW SERVICES; HEALTH CARE COST MANAGEMENT SERVICES FOR GOVERNMENT SPONSORED HEALTH CARE BENEFIT PROGRAMS (U.S. CLS. 100, 101 AND 102).

CLASS 36—INSURANCE AND FINANCIAL

FOR ADMINISTRATION OF PRESCRIPTION DRUG BENEFIT PROGRAMS; ADMINISTRATION OF PHARMACY BENEFIT PROGRAMS; PRESCRIPTION DRUG AND PHARMACY BENEFIT CLAIMS PROCESSING SERVICES; NETWORK PHARMACY BENEFIT MANAGEMENT SERVICES; ORGANIZING AND ADMINISTERING PREFERRED PROVIDER PLANS FOR A NETWORK OF PHARMACY PROVIDERS; PROVIDING ON-LINE INFORMATION IN THE FIELD OF MEDICARE PHARMACY BENEFITS; PRESCRIPTION DRUG INSURANCE UNDERWRITING FOR MEDICARE BENEFICIARIES (U.S. CLS. 100, 101 AND 102).

HELENE LIWINSKI, EXAMINING ATTORNEY

SN 85-350,170. PROSPECTS SOFTWARE INC., MONTREAL, CANADA, FILED 6-20-2011.

MLS-TOUCH

THE MARK CONSISTS OF STANDARD CHARACTERS WITHOUT CLAIM TO ANY PARTICULAR FONT, STYLE, SIZE, OR COLOR.

CLASS 9—ELECTRICAL AND SCIENTIFIC APPARATUS

FOR COMPUTER SOFTWARE FOR USE IN THE REAL ESTATE INDUSTRY THAT PROVIDES REAL ESTATE LISTINGS, MAPS, INFORMATION ON REAL ESTATE SALES AND CUSTOMER RELATIONSHIP MANAGEMENT (CRM), THAT MAY BE DOWNLOADED FROM A GLOBAL COMPUTER NETWORK (U.S. CLS. 21, 23, 26, 36 AND 38).

CLASS 42—SCIENTIFIC AND COMPUTER SERVICES

FOR PROVIDING A WEB SITE FEATURING TEMPORARY USE OF NON-DOWNLOADABLE SOFTWARE FOR USE IN THE REAL ESTATE INDUSTRY THAT PROVIDES REAL ESTATE LISTINGS, MAPS, INFORMATION ON REAL ESTATE SALES AND CUSTOMER RELATIONSHIP MANAGEMENT (CRM) (U.S. CLS. 100 AND 101).

KIM SAITO, EXAMINING ATTORNEY

SN 85-350,347. VOLVO CAR CORPORATION, AKA VOLVO PERSONVAGNAR AB, GOTEBORG, SWEDEN, FILED 6-20-2011.

CLASS 39—TRANSPORTATION AND STORAGE

FOR COMPUTER SERVICES, NAMELY, ELECTRONIC STORAGE OF INFORMATION, DOCUMENTS AND CONTENT FROM DATABASES, NEWSPAPERS, PERIODICALS, JOURNALS, DISSERTATIONS AND OTHER PUBLICATIONS (U.S. CLS. 100 AND 105).

CLASS 42—SCIENTIFIC AND COMPUTER SERVICES

FOR PROVIDING SEARCH ENGINES FOR RETRIEVAL OF INFORMATION, DOCUMENTS AND CONTENT FROM DATABASES, NEWSPAPERS, PERIODICALS, JOURNALS, DISSERTATIONS AND OTHER PUBLICATIONS ON A GLOBAL COMPUTER NETWORK (U.S. CLS. 100 AND 101).

VIVIAN MICZNIK FIRST, EXAMINING ATTORNEY

DESIGNED AROUND YOU

THE MARK CONSISTS OF STANDARD CHARACTERS WITHOUT CLAIM TO ANY PARTICULAR FONT, STYLE, SIZE, OR COLOR.

PRIORITY CLAIMED UNDER SEC. 44(D) ON SWEDEN APPLICATION NO. 2011/04871, FILED 6-8-2011, REG. NO. 501014, DATED 10-7-2011, EXPIRES 10-7-2021.

CLASS 12—VEHICLES

FOR LAND VEHICLES AND STRUCTURAL PARTS THEREFOR (U.S. CLS. 19, 21, 23, 31, 35 AND 44).

CLASS 35—ADVERTISING AND BUSINESS

FOR PROMOTING THE SALE OF GOODS AND SERVICES OF OTHERS THROUGH DISTRIBUTION OF PRINTED AND AUDIOVISUAL MATERIALS IN THE FIELD OF MOTOR VEHICLES AND BY RENDERING SALES PROMOTION ADVICE; ADVERTISING AND PROMOTIONAL SERVICES IN THE FIELD OF MOTOR VEHICLES (U.S. CLS. 100, 101 AND 102).

KATHLEEN LORENZO, EXAMINING ATTORNEY

SN 85-351,158. PROQUEST LLC, ANN ARBOR, MI. FILED 6-20-2011.



The logo for ProQuest, featuring the word "ProQuest" in a serif font. The letter "Q" is stylized with a long, wavy tail that extends below the baseline and curves back up to the right. A thin, horizontal arc underlines the letters "PRO" and "UEST".

OWNER OF U.S. REG. NOS. 1,656,697, 2,468,946 AND 2,751,655.

THE MARK CONSISTS OF THE WORD "PROQUEST" CONTAINING A CAPITAL "P" AND A STYLIZED CAPITAL "Q" THAT HAS AN ELONGATED WAVY TAIL. THE REMAINING LETTERS ARE IN LOWER CASE, AND THERE IS A THIN UNDERLINING ARC BENEATH THE "PRO" AND "UEST" PORTIONS OF THE MARK.

CLASS 38—COMMUNICATION

FOR COMPUTER SERVICES, NAMELY, ELECTRONIC TRANSMISSION OF INFORMATION, DOCUMENTS AND CONTENT FROM DATABASES, NEWSPAPERS, PERIODICALS, JOURNALS, DISSERTATIONS AND OTHER PUBLICATIONS (U.S. CLS. 100, 101 AND 104).

SN 85-351,428. HERBACEOUS ACRES INCORPORATED, UPPER MARLBORO, MD. FILED 6-21-2011.



NO CLAIM IS MADE TO THE EXCLUSIVE RIGHT TO USE "HERBACEOUS", APART FROM THE MARK AS SHOWN.

THE COLOR(S) GREEN, BLACK, BROWN AND GREY IS/ARE CLAIMED AS A FEATURE OF THE MARK.

THE MARK CONSISTS OF THE WORDS "HERBACEOUS ACRES" IN ARIAL BLACK TYPE FONT IN A HALF CIRCLE IN THE COLOR BLACK. UNDER THE LETTERING IS A YOUNG MUSTARD TREE IN THE COLORS GREEN, BROWN, GREY AND BLACK. THE TREE IS CASTING A GREY SHADOW BEHIND AND TO THE LEFT. THE TREE IS CENTERED BELOW "HERBACEOUS ACRES" LETTERING.

CLASS 3—COSMETICS AND CLEANING PREPARATIONS

FOR NON-MEDICATED HERBAL BODY CARE PRODUCTS, NAMELY, BODY OILS, SALVES, AND LIP BALMS (U.S. CLS. 1, 4, 6, 50, 51 AND 52).

FIRST USE 2-10-2009; IN COMMERCE 6-30-2011.

CLASS 4—LUBRICANTS AND FUELS

FOR AROMATHERAPY FRAGRANCE CANDLES; CANDLES; CANDLES FOR LIGHTING; SCENTED CANDLES (U.S. CLS. 1, 6 AND 15).

FIRST USE 2-10-2009; IN COMMERCE 6-30-2011.

CLASS 30—STAPLE FOODS

FOR HERBAL INFUSIONS (U.S. CL. 46).

FIRST USE 2-10-2009; IN COMMERCE 6-30-2011.

CLASS 31—NATURAL AGRICULTURAL PRODUCTS

FOR FRESH CULINARY HERBS (U.S. CLS. 1 AND 46).
FIRST USE 2-10-2009; IN COMMERCE 6-30-2011.
RUDY R. SINGLETON, EXAMINING ATTORNEY

SN 85-351,755. COVIDIEN AG, NEUHAUSEN AM RHEINFALL, SWITZERLAND, FILED 6-21-2011.

CHEMOPLUS

THE MARK CONSISTS OF STANDARD CHARACTERS WITHOUT CLAIM TO ANY PARTICULAR FONT, STYLE, SIZE, OR COLOR.

OWNER OF U.S. REG. NO. 1,631,472.

SN 85-351,480. INTERQUIM S.A., BARCELONA, SPAIN, FILED 6-21-2011.

CITROSTEROL

THE MARK CONSISTS OF STANDARD CHARACTERS WITHOUT CLAIM TO ANY PARTICULAR FONT, STYLE, SIZE, OR COLOR.

CLASS 5—PHARMACEUTICALS

FOR DIETETIC SUBSTANCES ADAPTED FOR MEDICAL USE, NAMELY, DIETETIC SUGAR, DIETETIC FOODS ADAPTED FOR MEDICAL USE, FOOD FOR BABIES; NUTRITIONAL SUPPLEMENTS AND ADDITIVES FOR MEDICAL PURPOSES FOR USE IN FOODS WITH ANTIOXIDANT PROPERTIES AND/OR CARDIOVASCULAR PROTECTION PROPERTIES AND DIETARY SUPPLEMENTS FOR HUMAN CONSUMPTION; NUTRACEUTICAL PRODUCTS FOR USE AS A DIETARY SUPPLEMENTS, PROMOTING DIGESTION, HAVING CARDIOVASCULAR PROTECTION PROPERTIES AND/OR ANTIOXIDANT PROPERTIES; ALL THE AFOREMENTIONED CONTAINING NATURAL EXTRACTS OF CITRUS FRUITS (U.S. CLS. 6, 18, 44, 46, 51 AND 52).

CLASS 29—MEATS AND PROCESSED FOODS

FOR MEAT, FISH, POULTRY AND GAME; MEAT EXTRACTS; PRESERVED, FROZEN, DRIED AND COOKED FRUITS AND VEGETABLES; JELLIES, JAMS, COMPOTES; EGGS, MILK AND MILK PRODUCTS EXCLUDING ICE CREAM, ICE MILK, AND FROZEN YOGURT; EDIBLE OILS AND FATS, ALL OF THE AFOREMENTIONED PRODUCTS CONTAINING NATURAL EXTRACTS OF CITRUS FRUITS (U.S. CL. 46).

CLASS 32—LIGHT BEVERAGES

FOR BEERS; MINERAL AND AERATED WATERS AND OTHER NON-ALCOHOLIC DRINKS, NAMELY, ENERGY SHOTS, SPORT DRINKS, SOFT DRINKS; FRUIT DRINKS AND FRUIT JUICES; SYRUPS AND OTHER PREPARATIONS IN THE NATURE OF POWDERS, CONCENTRATES FOR MAKING BEVERAGES BEING FRUIT DRINKS, ENERGY DRINKS, SPORT DRINKS, SOFT DRINKS WHICH HAVE AN ADDED HEALTH COMPONENT, SUCH AS NATURAL EXTRACTS OF CITRUS FRUITS BUT NOT FOR MEDICAL PURPOSES (U.S. CLS. 45, 46 AND 48).
JACLYN KIDWELL WALKER, EXAMINING ATTORNEY

CLASS 9—ELECTRICAL AND SCIENTIFIC APPARATUS

FOR SAFETY GLASSES AND GOGGLES FOR MEDICAL USE (U.S. CLS. 21, 23, 26, 36 AND 38).

CLASS 10—MEDICAL APPARATUS

FOR GLOVES FOR MEDICAL USE; MEDICAL GOWNS AND COATS; IV BAG SEALS; MEDICAL WASTE BAGS, BAGS TO TRANSPORT CHEMOTHERAPY DRUGS (U.S. CLS. 26, 39 AND 44).

CLASS 27—FLOOR COVERINGS

FOR CONTAMINATION CONTROL FLOOR MATS FOR MEDICAL USE; ABSORBENT FLOOR PADS (U.S. CLS. 19, 20, 37, 42 AND 50).
DANNEAN HETZEL, EXAMINING ATTORNEY

SN 85-351,847. PERSHING INVESTMENTS LLC, NEWARK, DE. FILED 6-21-2011.

CORESTONE

THE MARK CONSISTS OF STANDARD CHARACTERS WITHOUT CLAIM TO ANY PARTICULAR FONT, STYLE, SIZE, OR COLOR.

CLASS 16—PAPER GOODS AND PRINTED MATTER

FOR PRINTED BANK CHECKS, CHECKBOOK REGISTERS, CHECKBOOK COVERS AND CHECKING DEPOSIT SLIPS; PRINTED PUBLICATIONS, NAMELY, INVESTOR-TARGETED BROCHURES AND PRODUCT OVERVIEW FACT SHEETS; BULLETINS AND NEWSLETTERS IN THE FIELD OF ASSET MANAGEMENT AND INVESTMENT PROFESSIONAL COMMUNICATIONS (U.S. CLS. 2, 5, 22, 23, 29, 37, 38 AND 50).

CLASS 36—INSURANCE AND FINANCIAL

FOR FINANCIAL SERVICES, NAMELY, ASSET MANAGEMENT ACCOUNTS COMPRISED OF CHECKING ACCOUNT SERVICES, INVESTMENT MANAGEMENT SERVICES, MARGIN LENDING SERVICES, DEBIT AND CREDIT CARD SERVICES, AND AUTOMATIC BILL PAYING SERVICES FOR BROKERAGE ACCOUNT ASSETS AND ASSETS HELD IN MONEY-MARKET FUNDS AND MARGIN ACCOUNTS (U.S. CLS. 100, 101 AND 102).
KAREN BRACEY, EXAMINING ATTORNEY

SN 85-351,866. PERSHING INVESTMENTS LLC, NEWARK, DE. FILED 6-21-2011.

CORESTONE ACCOUNT

THE MARK CONSISTS OF STANDARD CHARACTERS WITHOUT CLAIM TO ANY PARTICULAR FONT, STYLE, SIZE, OR COLOR.

NO CLAIM IS MADE TO THE EXCLUSIVE RIGHT TO USE "ACCOUNT", APART FROM THE MARK AS SHOWN.

CLASS 16—PAPER GOODS AND PRINTED MATTER

FOR PRINTED BANK CHECKS, CHECKBOOK REGISTERS, CHECKBOOK COVERS AND CHECKING DEPOSIT SLIPS; PRINTED PUBLICATIONS, NAMELY, INVESTOR-TARGETED BROCHURES AND PRODUCT OVERVIEW FACT SHEETS; BULLETINS AND NEWSLETTERS IN THE FIELD OF ASSET MANAGEMENT AND INVESTMENT PROFESSIONAL COMMUNICATIONS (U.S. CLS. 2, 5, 22, 23, 29, 37, 38 AND 50).

CLASS 36—INSURANCE AND FINANCIAL

FOR FINANCIAL SERVICES, NAMELY, ASSET MANAGEMENT ACCOUNTS COMPRISED OF CHECKING ACCOUNT SERVICES, INVESTMENT MANAGEMENT SERVICES, MARGIN LENDING SERVICES, DEBIT AND CREDIT CARD SERVICES, AND AUTOMATIC BILL PAYING SERVICES FOR BROKERAGE ACCOUNT ASSETS AND ASSETS HELD IN MONEY-MARKET FUNDS AND MARGIN ACCOUNTS (U.S. CLS. 100, 101 AND 102).
KAREN BRACEY, EXAMINING ATTORNEY

SN 85-352,342. HC SOLAR POWER CO., LTD., ZHEJIANG PROVINCE, CHINA, FILED 6-21-2011.



NO CLAIM IS MADE TO THE EXCLUSIVE RIGHT TO USE "SOLAR", APART FROM THE MARK AS SHOWN.

THE MARK CONSISTS OF THE WORDING "HC SOLAR THE BRIGHTER SIDE OF LIFE" WITH AN ARROW DESIGN TO THE LEFT OF THE WORDING.

CLASS 9—ELECTRICAL AND SCIENTIFIC APPARATUS

FOR GALVANIC CELLS; SINGLE CRYSTAL SILICON WAFERS; SILICON EXTENDING SLICE, NAMELY, WAFERS BEING SILICON EXTENDING SLICE; POLY-SILICON WAFERS; SEMICONDUCTOR APPARATUS; SOLAR BATTERIES; JUNCTION BOXES; ACCUMULATORS, ELECTRIC; BATTERY CHARGERS; CHIPS, NAMELY, INTEGRATED CIRCUITS FOR USE AS COMPONENTS OF SOLAR MODULE MANUFACTURING MACHINES; INVERTERS; ELECTRICAL CELL SWITCHES; ALTERNATING CURRENT CONTROLLER; DIRECT CURRENT CONTROLLER FOR CONTROLLING ELECTRICITY; LIGHTNING PROTECTION JUNCTION BOX; PRESERVING-HEAT BOX OF STORAGE BATTERY; ELECTRIC POWER DISTRIBUTION EQUIPMENT; LIGHTNING PROTECTION BOX FOR LIMITING LIGHTNING IMPULSE HIGH-VOLTAGE VOLTAGE AND ELECTRICAL APPARATUS FAULT, NAMELY, VOLTAGE SURGE PROTECTORS AND SUPPRESSORS FOR LIGHTNING PROTECTION (U.S. CLS. 21, 23, 26, 36 AND 38).

CLASS 11—ENVIRONMENTAL CONTROL APPARATUS

FOR STREET LAMPS; SOLAR COLLECTORS; SUN ENERGY WATER HEATER; LIGHTING APPARATUS AND EQUIPMENT, NAMELY, LIGHTING INSTALLATIONS; WATER HEATERS; PORTABLE ELECTRIC POCKET WARMERS; SOLAR FURNACES; SOLAR ENERGY COLLECTORS; BATHROOM HEATER, NAMELY, ELECTRIC HEATING DRYERS FOR BATHROOMS FOR HOUSEHOLD PURPOSES, NAMELY, ELECTRIC BATHROOM HEATERS, ELECTRIC BATHROOM FAN DRYER, ELECTRIC WATER HEATER; LAMP MANTLES (U.S. CLS. 13, 21, 23, 31 AND 34).

CLASS 19—NON-METALLIC BUILDING MATERIALS

FOR ROOFING BOARD, NOT OF METAL, COMPOSED OF SOLAR CELLS; LIGHTING SLABS; TILES, NOT OF METAL; BUILDINGS, NOT OF METAL; CEMENT; LUMBER; POLES, NOT OF METAL, FOR ELECTRIC POWER LINES; CONCRETE BUILDING ELEMENTS; FELT FOR BUILDING; WOODEN FLOOR (U.S. CLS. 1, 12, 33 AND 50).

SHAILA SETTLES, EXAMINING ATTORNEY

SN 85-352,644. WHAT'S COOKING GOOD LOOKING, LLC, GREENWICH, CT. FILED 6-22-2011.

WHAT'S COOKING GOOD LOOKING

THE MARK CONSISTS OF STANDARD CHARACTERS WITHOUT CLAIM TO ANY PARTICULAR FONT, STYLE, SIZE, OR COLOR.

CLASS 43—HOTEL AND RESTAURANT SERVICES

FOR PROVIDING A WEBSITE FEATURING INFORMATION ABOUT COOKING AND FEATURING HEALTHY RECIPES (U.S. CLS. 100 AND 101).

CLASS 44—MEDICAL, BEAUTY AND AGRICULTURAL SERVICES

FOR PROVIDING A WEBSITE FEATURING INFORMATION ABOUT NUTRITION, HEALTH AND WELLNESS (U.S. CLS. 100 AND 101).

ELISSA GARBER KON, EXAMINING ATTORNEY

SN 85-352,835. STRIDE TOOL INC., ELLICOTTVILLE, NY.
FILED 6-22-2011.

PROFESSIONALS' CHOICE

THE MARK CONSISTS OF STANDARD CHARACTERS WITHOUT CLAIM TO ANY PARTICULAR FONT, STYLE, SIZE, OR COLOR.

CLASS 7—MACHINERY

FOR TOOLS, NAMELY, POWER-OPERATED TOOLS FOR PAINTING AND DRYWALL, NAMELY, SPRAY PAINT SYSTEMS COMPRISED OF PUMPS, PUMP CONTROLLERS, NOZZLES, TUBING AND VALVES; TIPS FOR PAINT SPRAY GUNS; PAINT SPRAY GUNS; POWER-OPERATED TEXTURE GUNS AND ACCESSORIES SPECIFICALLY DESIGNED THEREFOR, NAMELY, TEXTURE BRUSHES AND TEXTURE SPRAYERS, AND STRUCTURAL PARTS THEREFOR; POWER-OPERATED HOPPER GUNS; POWER-OPERATED AIRLESS TEXTURE SPRAYER SYSTEMS COMPRISED OF SPRAYERS, HOSES, AND STRUCTURAL PARTS THEREOF; ELECTRIC SAWS (U.S. CLS. 13, 19, 21, 23, 31, 34 AND 35).

CLASS 8—HAND TOOLS

FOR TOOLS, NAMELY, HAND-OPERATED TOOLS FOR PAINTING AND DRYWALL, NAMELY, PAINT SCRAPERS, PAINT TRIM GUIDES, DRAW TAPE REELS, SCRAPERS, SANDERS, PUTTY KNIVES; HAND TOOLS FOR SKIMMING WALL REPAIRS IN SMALL OR TIGHT AREAS WITH JOINT COMPOUND, PUTTY OR SMOOTHING VINYL LETTERING; SANDING SPONGES, RUBBING BRICKS FOR SANDING, ROLLERS AND BRUSHES FOR APPLYING ADHESIVES; HAND-OPERATED CUTTING TOOLS; HAND OPERATED CUTTING TOOLS, NAMELY, BOX CUTTERS; KNIVES; HAND-OPERATED TEXTURE GUNS AND ACCESSORIES SPECIFICALLY DESIGNED THEREFOR, NAMELY, TEXTURE BRUSHES AND TEXTURE SPRAYERS, AND STRUCTURAL PARTS THEREFOR; HAND-OPERATED HOPPER GUNS; DRYWALL TOOLS, NAMELY, HAND TOOL FOR AIDING THE LIFTING AND CARRYING OF DRYWALL, MANUAL HOISTS; HAND SAWS; DRYWALL TOOLS, NAMELY, PLASTER MUD PANS, HAND TOOL TO REMOVE EXCESS MUD IN THE NATURE OF PUTTY KNIVES, SCRAPERS, JOINT KNIVES, AND SPATULAS; HAND-OPERATED DRYWALL TOOLS, NAMELY, DRYWALL SAWS, STRIPPERS, HAMMERS, CUTTERS, LIFTERS AND RASPS (U.S. CLS. 23, 28 AND 44).

CLASS 16—PAPER GOODS AND PRINTED MATTER

FOR TOOLS, NAMELY, TOOLS FOR PAINTING, NAMELY, PAINT APPLICATORS, PAINT APPLICATORS IN THE NATURE OF SPONGES, PAINT TRAY LINERS OF PAPER OR PLASTIC, PAINT TRAYS, AND ROLLERS AND BRUSHES FOR APPLYING PAINT (U.S. CLS. 2, 5, 22, 23, 29, 37, 38 AND 50).

CLASS 17—RUBBER GOODS

FOR PAINT SHIELDS, NAMELY, SHEETS OF ADHESIVE PLASTIC FILM USED TO COVER AND PROTECT OBJECTS WHILE PAINTING (U.S. CLS. 1, 5, 12, 13, 35 AND 50).

CLASS 19—NON-METALLIC BUILDING MATERIALS

FOR TOOLS, NAMELY, DRYWALL TOOLS, NAMELY, DRYWALL CORNER BEADS NOT OF METAL (U.S. CLS. 1, 12, 33 AND 50).

NICHOLAS COLEMAN, EXAMINING ATTORNEY

SN 85-352,906. FANLAND, INC., LANSDALE, PA. FILED 6-22-2011.

FanLand

THE MARK CONSISTS OF STANDARD CHARACTERS WITHOUT CLAIM TO ANY PARTICULAR FONT, STYLE, SIZE, OR COLOR.

CLASS 35—ADVERTISING AND BUSINESS

FOR PROVIDING A WEBSITE FEATURING AN ONLINE MARKETPLACE FOR CONNECTING BUYERS AND SELLERS OF TICKETS FOR SPORTS EVENTS; PROVIDING AN ONLINE MARKETPLACE FOR CONNECTING BUYERS AND SELLERS OF SPORTS TEAM APPAREL AND SPORTS TEAM MERCHANDISE WHICH FEATURES PRICE COMPARISON INFORMATION (U.S. CLS. 100, 101 AND 102).

CLASS 38—COMMUNICATION

FOR INTERNET DESTINATION TO BETTER CONNECT INTERNET USERS WITH THEIR FAVORITE SPORTS TEAMS, NAMELY PROVIDING AN ONLINE CHAT ROOM AND ELECTRONIC BULLETIN BOARD FOR TRANSMISSION OF MESSAGES AND IMAGES AMONG USERS IN THE FIELD OF SPORTS AND SPORTS TEAMS (U.S. CLS. 100, 101 AND 104).

CLASS 41—EDUCATION AND ENTERTAINMENT

FOR PROVIDING INFORMATION AND NEWS VIA THE INTERNET, WIRELESS NETWORKS AND MOBILE DEVICES IN THE FIELD OF SPORTS AND SPORTS TEAMS (U.S. CLS. 100, 101 AND 107).

ELLEN PERKINS, EXAMINING ATTORNEY

SN 85-354,434. EST 19XX, LLC, NEW YORK, NY. FILED 6-23-2011.

MGK

THE MARK CONSISTS OF STANDARD CHARACTERS WITHOUT CLAIM TO ANY PARTICULAR FONT, STYLE, SIZE, OR COLOR.

CLASS 25—CLOTHING

FOR CLOTHING FOR MEN, WOMEN AND CHILDREN, NAMELY, SHORT-SLEEVED OR LONG-SLEEVED T-SHIRTS; T-SHIRTS, SWEATERS, COATS, SPORTS JACKETS, SPORTS JERSEYS, SPORTS SHIRTS, HATS, SWEATSHIRTS, SHORTS AND PANTS (U.S. CLS. 22 AND 39).

FIRST USE 12-1-2005; IN COMMERCE 1-15-2011.

CLASS 41—EDUCATION AND ENTERTAINMENT

FOR ENTERTAINMENT SERVICES IN THE NATURE OF LIVE MUSICAL PERFORMANCES; ENTERTAINMENT, NAMELY, LIVE MUSIC CONCERTS; PRODUCTION OF AUDIO RECORDING (U.S. CLS. 100, 101 AND 107).

FIRST USE 12-1-2005; IN COMMERCE 10-1-2009.
CAROLYN CATALDO, EXAMINING ATTORNEY

SN 85-357,091. SCHOELS, KRISTEN MICHELLE, NEW YORK, NY. FILED 6-27-2011.

Young Married Chic

THE MARK CONSISTS OF STANDARD CHARACTERS WITHOUT CLAIM TO ANY PARTICULAR FONT, STYLE, SIZE, OR COLOR.

CLASS 41—EDUCATION AND ENTERTAINMENT

FOR ON-LINE JOURNALS, NAMELY, BLOGS FEATURING DAILY RECIPES, HOME DECOR INSPIRATION, TRAVEL ARTICLES AND ENTERTAINING IDEAS; PROVIDING A WEBSITE FEATURING BLOGS AND NON-DOWNLOADABLE PUBLICATIONS IN THE NATURE OF ARTICLES IN THE FIELD(S) OF FOOD, FASHION, HOME DECOR AND ENTERTAINING IDEAS (U.S. CLS. 100, 101 AND 107).

FIRST USE 1-1-2009; IN COMMERCE 1-1-2010.

CLASS 42—SCIENTIFIC AND COMPUTER SERVICES

FOR PROVIDING CUSTOMIZED ON-LINE WEB PAGES AND DATA FEEDS FEATURING USER-DEFINED INFORMATION, WHICH INCLUDES BLOG POSTS, NEW MEDIA CONTENT, OTHER ON-LINE CONTENT, AND ON-LINE WEB LINKS TO OTHER WEBSITES (U.S. CLS. 100 AND 101).

FIRST USE 1-1-2009; IN COMMERCE 1-1-2010.
KAPIL BHANOT, EXAMINING ATTORNEY

SN 85-357,316. PRIDESTAFF, INC., FRESNO, CA. FILED 6-27-2011.

INNOVATIONS

THE MARK CONSISTS OF STANDARD CHARACTERS WITHOUT CLAIM TO ANY PARTICULAR FONT, STYLE, SIZE, OR COLOR.

CLASS 16—PAPER GOODS AND PRINTED MATTER

FOR PRINT NEWSLETTERS COVERING TOPICS OF INTEREST TO EMPLOYERS IN THE FIELD OF HUMAN RESOURCES, INCLUDING BUT NOT LIMITED TO STAFFING, TRAINING, RECRUITING, LEGAL COMPLIANCE, AND PERSONNEL MANAGEMENT (U.S. CLS. 2, 5, 22, 23, 29, 37, 38 AND 50).

FIRST USE 8-0-2006; IN COMMERCE 8-0-2006.

CLASS 41—EDUCATION AND ENTERTAINMENT

FOR NON-DOWNLOADABLE ELECTRONIC NEWSLETTERS COVERING TOPICS OF INTEREST TO EMPLOYERS IN THE FIELD OF HUMAN RESOURCES, INCLUDING BUT NOT LIMITED TO STAFFING, TRAINING, RECRUITING, LEGAL COMPLIANCE, AND PERSONNEL MANAGEMENT; EDUCATIONAL SERVICES IN THE FORM OF WEBINARS COVERING TOPICS OF INTEREST TO EMPLOYERS IN THE FIELD OF HUMAN RESOURCES, INCLUDING BUT NOT LIMITED TO STAFFING, TRAINING, RECRUITING, LEGAL COMPLIANCE, AND PERSONNEL MANAGEMENT (U.S. CLS. 100, 101 AND 107).

FIRST USE 8-0-2006; IN COMMERCE 8-0-2006.
KAREN SEVERSON, EXAMINING ATTORNEY

SN 85-357,444. VISIONARY INTEGRATION PROFESSIONALS, LLC, FOLSOM, CA. FILED 6-27-2011.



OWNER OF U.S. REG. NO. 3,486,907.

NO CLAIM IS MADE TO THE EXCLUSIVE RIGHT TO USE "INTEGRATION PROFESSIONALS", APART FROM THE MARK AS SHOWN.

THE MARK CONSISTS OF AN UPPER CASE "V" IN A FANCIFUL FONT WITH THE LOWER CASE LETTER "I" INTEGRATED INTO THE RIGHT SIDE OF THE "V" WHERE THE DOT OF THE "I" APPEARS OVER THE "V" AND THE LOWER PART OF THE "I" APPEARS BELOW THE "V". A LOWER CASE "P" TO THE RIGHT OF THE LOWER PART OF THE "I". A VERTICAL LINE BETWEEN THE "P" FROM THE WORDS "VISIONARY INTEGRATION PROFESSIONALS" WHERE "VISIONARY" IS IN LARGER FONT THAN "INTEGRATION PROFESSIONALS" AND "INTEGRATION PROFESSIONALS" IS BELOW AND EXTENDS PAST THE TERM "VISIONARY".

CLASS 35—ADVERTISING AND BUSINESS

FOR BUSINESS MANAGEMENT SERVICES RELATING TO STRATEGIC BUSINESS PLANNING, PROJECT MANAGEMENT, PROJECT OVERSIGHT, BUSINESS CASE ANALYSIS AND FEASIBILITY STUDIES, ACQUISITION AND PROCUREMENT, ORGANIZATIONAL CHANGE, AND PROCESS IMPROVEMENT (U.S. CLS. 100, 101 AND 102).

FIRST USE 10-0-2009; IN COMMERCE 10-0-2009.

CLASS 37—CONSTRUCTION AND REPAIR

FOR MAINTENANCE OF COMPUTER HARDWARE SYSTEMS (U.S. CLS. 100, 103 AND 106).

FIRST USE 10-0-2009; IN COMMERCE 10-0-2009.

CLASS 38—COMMUNICATION

FOR TELECOMMUNICATION CONSULTATION IN THE NATURE OF TECHNICAL CONSULTING IN THE FIELD OF AUDIO, TEXT AND VISUAL DATA TRANSMISSION AND COMMUNICATION (U.S. CLS. 100, 101 AND 104).

FIRST USE 10-0-2009; IN COMMERCE 10-0-2009.

CLASS 41—EDUCATION AND ENTERTAINMENT

FOR COMPUTER EDUCATION TRAINING SERVICES (U.S. CLS. 100, 101 AND 107).

FIRST USE 10-0-2009; IN COMMERCE 10-0-2009.

CLASS 42—SCIENTIFIC AND COMPUTER SERVICES

FOR TECHNOLOGY SERVICES, NAMELY, COMPUTER SOFTWARE DEVELOPMENT AND INTEGRATION OF COMPUTER SYSTEMS AND NETWORKS, COMPUTER SOFTWARE APPLICATION PERFORMANCE TESTING, NAMELY, LOAD TESTING, SYSTEM TESTING, AND ENHANCEMENTS PERFORMANCE TESTING, DATA WAREHOUSING, CUSTOMIZATION OF COMPUTER SOFTWARE, COMPUTER SOFTWARE TESTING, AND MAINTENANCE OF COMPUTER SOFTWARE (U.S. CLS. 100 AND 101).

FIRST USE 10-0-2009; IN COMMERCE 10-0-2009.

YAT SYE, LEE, EXAMINING ATTORNEY

SN 85-359,317. PETERSON FARMS, INC., SHELBY, MI. FILED 6-29-2011.

ORCHARD ORIGINALS

THE MARK CONSISTS OF STANDARD CHARACTERS WITHOUT CLAIM TO ANY PARTICULAR FONT, STYLE, SIZE, OR COLOR.

CLASS 29—MEATS AND PROCESSED FOODS

FOR FRUIT-BASED FILLING FOR PIES (U.S. CL. 46). FIRST USE 5-0-2011; IN COMMERCE 5-0-2011.

CLASS 32—LIGHT BEVERAGES

FOR FROZEN FRUIT SMOOTHIES MIX (U.S. CLS. 45, 46 AND 48).

FIRST USE 5-0-2011; IN COMMERCE 5-0-2011.

GIANCARLO CASTRO, EXAMINING ATTORNEY

SN 85-360,592. OPTICAL FUSION, INC., PALO ALTO, CA. FILED 6-30-2011.

VIDEO MONET

THE MARK CONSISTS OF STANDARD CHARACTERS WITHOUT CLAIM TO ANY PARTICULAR FONT, STYLE, SIZE, OR COLOR.

NO CLAIM IS MADE TO THE EXCLUSIVE RIGHT TO USE "VIDEO", APART FROM THE MARK AS SHOWN.

CLASS 9—ELECTRICAL AND SCIENTIFIC APPARATUS

FOR COMPUTER SOFTWARE FOR CONTROLLING THE OPERATION OF AUDIO AND VIDEO DEVICES; COMPUTER SOFTWARE FOR INTERCONNECTING, INTEGRATING, SECURING, MANAGING, MONITORING, AND OPERATING VIDEO CONFERENCING SYSTEMS; COMPUTER SOFTWARE FOR ENABLING MULTI-LOCATION VIDEO CONFERENCING; COMPUTER SOFTWARE WHICH ALLOWS USERS TO PARTICIPATE IN WEB-BASED MEETINGS (U.S. CLS. 21, 23, 26, 36 AND 38).

CLASS 38—COMMUNICATION

FOR TELECONFERENCING AND VIDEO CONFERENCING SERVICES; WEB-BASED MULTIMEDIA TELECONFERENCING SERVICES (U.S. CLS. 100, 101 AND 104).

CLASS 42—SCIENTIFIC AND COMPUTER SERVICES

FOR TEMPORARY USE OF NON-DOWNLOADABLE COMPUTER SOFTWARE FOR CONTROLLING THE OPERATION OF AUDIO AND VIDEO DEVICES, FOR INTERCONNECTING, INTEGRATING, SECURING, MANAGING, MONITORING, AND OPERATING VIDEO CONFERENCING SYSTEMS, FOR ENABLING MULTI-LOCATION VIDEO CONFERENCING, AND FOR ENABLING USERS TO PARTICIPATE IN WEB-BASED MEETINGS; VIDEO CONFERENCING PLANNING, DESIGN, AND IMPLEMENTATION SERVICES, NAMELY, PLANNING, DESIGN, AND IMPLEMENTATION OF SOFTWARE FOR VIDEO CONFERENCING; TECHNICAL SUPPORT SERVICES FOR COMPUTER NETWORKS AND VIDEO CONFERENCING SOLUTIONS, NAMELY, DIAGNOSING COMPUTER HARDWARE AND SOFTWARE PROBLEMS; COMPUTER SERVICES, NAMELY, NETWORK AND VIDEO CONFERENCING SOLUTION MANAGEMENT IN THE NATURE OF TROUBLESHOOTING SYSTEMS OR SOFTWARE PROBLEMS AND MONITORING SERVICES, NAMELY, TROUBLESHOOTING OF COMPUTER SOFTWARE PROBLEMS, MONITORING OF NETWORK SYSTEMS, REMOTE COMPUTER NETWORK TECHNICAL MONITORING AND SOFTWARE MAINTENANCE SERVICES, MONITORING OF COMPUTER SYSTEMS OF OTHERS FOR TECHNICAL PURPOSES AND PROVIDING BACK-UP COMPUTER PROGRAMS AND FACILITIES, COMPUTER MONITORING SERVICE WHICH TRACKS APPLICATION SOFTWARE PERFORMANCES, PERFORMS PERIODIC MAINTENANCE, AND PROVIDES REPORTS AND ALERTS CONCERNING SUCH PERFORMANCE (U.S. CLS. 100 AND 101).

KATHERINE CONNOLLY, EXAMINING ATTORNEY

SN 85-361,245. EYES 4 LIVES, INC., WEST COVINA, CA. FILED 6-30-2011.

Dr. i-Coach

THE MARK CONSISTS OF STANDARD CHARACTERS WITHOUT CLAIM TO ANY PARTICULAR FONT, STYLE, SIZE, OR COLOR.

CLASS 9—ELECTRICAL AND SCIENTIFIC APPARATUS

FOR ELECTRONIC DEVICES THAT MINIMIZE COMPUTER VISION SYNDROME AND THE PROGRESSION OF NEARSIGHTEDNESS BY CORRECTING IMPROPER ELECTRONIC USAGE HABITS (U.S. CLS. 21, 23, 26, 36 AND 38).

FIRST USE 6-30-2011; IN COMMERCE 6-30-2011.

CLASS 35—ADVERTISING AND BUSINESS

FOR ON-LINE RETAIL STORE SERVICES FEATURING ELECTRONIC DEVICES THAT MINIMIZE COMPUTER VISION SYNDROME CVS AND THE PROGRESSION OF NEARSIGHTEDNESS BY CORRECTING IMPROPER ELECTRONIC USAGE HABITS (U.S. CLS. 100, 101 AND 102).

FIRST USE 6-30-2011; IN COMMERCE 6-30-2011.

JOHN WILKE, EXAMINING ATTORNEY

SN 85-361,263. EYES 4 LIVES, INC., WEST COVINA, CA. FILED 6-30-2011.



THE COLOR(S) WHITE, ORANGE, BLACK AND GRAY IS/ARE CLAIMED AS A FEATURE OF THE MARK.

THE MARK CONSISTS OF A GRAPHICAL DEPICTION OF A HUMAN EYE IN WHITE ON AN ORANGE BACKGROUND OVER THE LITERAL ELEMENT "DR. I-COACH" IN BLACK WITH A SQUARE ORANGE DOT OVER THE "I" ON A GRAY BACKGROUND ALL WITHIN A RECTANGLE OUTLINED IN BLACK WITH A BLACK LINE BETWEEN THE UPPER ORANGE AND LOWER GRAY SECTIONS OF THE RECTANGLE.

CLASS 9—ELECTRICAL AND SCIENTIFIC APPARATUS

FOR ELECTRONIC DEVICES THAT MINIMIZE COMPUTER VISION SYNDROME AND THE PROGRESSION OF NEARSIGHTEDNESS BY CORRECTING IMPROPER ELECTRONIC USAGE HABITS (U.S. CLS. 21, 23, 26, 36 AND 38).

FIRST USE 6-30-2011; IN COMMERCE 6-30-2011.

CLASS 35—ADVERTISING AND BUSINESS

FOR ON-LINE RETAIL STORE SERVICES FEATURING ELECTRONIC DEVICES THAT MINIMIZE COMPUTER VISION SYNDROME CVS AND THE PROGRESSION OF NEARSIGHTEDNESS BY CORRECTING IMPROPER ELECTRONIC USAGE HABITS (U.S. CLS. 100, 101 AND 102).

FIRST USE 6-30-2011; IN COMMERCE 6-30-2011.

JOHN WILKE, EXAMINING ATTORNEY

SN 85-361,933. DO-KYUN KIM, SEOUL, REPUBLIC OF KOREA, FILED 7-1-2011.

TOM N TOMS COFFEE

THE MARK CONSISTS OF STANDARD CHARACTERS WITHOUT CLAIM TO ANY PARTICULAR FONT, STYLE, SIZE, OR COLOR.

OWNER OF U.S. REG. NO. 3,530,315.

NO CLAIM IS MADE TO THE EXCLUSIVE RIGHT TO USE "COFFEE", APART FROM THE MARK AS SHOWN.

THE NAME(S), PORTRAIT(S), AND/OR SIGNATURE(S) SHOWN IN THE MARK DOES NOT IDENTIFY A PARTICULAR LIVING INDIVIDUAL.

CLASS 21—HOUSEWARES AND GLASS

FOR MUGS; INSULATED COFFEE CUPS; INSULATED BEVERAGE CUPS; CUPS; DISHES; PAPER PLATES; REUSABLE NON-PAPER COFFEE FILTERS; COASTERS NOT OF PAPER AND NOT BEING TABLE LINEN; THERMAL INSULATED BOTTLES; INSULATED VACUUM BOTTLES; NON-ELECTRIC COFFEE MAKERS; HAND-OPERATED COFFEE GRINDERS AND COFFEE MILLS; NON-ELECTRIC COFFEEPOTS OF PRECIOUS METAL; NON-ELECTRIC TEAPOTS; BEVERAGE GLASSWARE; DINNERWARE, NAMELY, PLATS AND BOWLS; STORAGE CONTAINERS FOR HOUSEHOLD USE FOR FOOD (U.S. CLS. 2, 13, 23, 29, 30, 33, 40 AND 50).

FIRST USE 12-15-1999; IN COMMERCE 12-1-2010.

CLASS 29—MEATS AND PROCESSED FOODS

FOR MILK; CHOCOLATE FLAVORED MILK; STRAWBERRY FLAVORED MILK; COFFEE FLAVORED MILK; MILK-BASED FOOD BEVERAGES CONTAINING COFFEE; MILK SHAKES; FLAVORING SYRUPS; LIQUID AND POWDERED BEVERAGE MIXES USED TO MAKE MILK-BASED FOOD BEVERAGES, NAMELY, MILK-BASED BEVERAGES CONTAINING COFFEE; DAIRY-BASED FOOD BEVERAGES; SOY-BASED FOOD BEVERAGE USED AS A MILK SUBSTITUTE; CRYSTALLIZED FRUITS; FERMENTED VEGETABLE FOODS, NAMELY, KIMCHI; POTATO FLAKES; FRUIT CHIPS; SOYA MILK (U.S. CL. 46).

CLASS 30—STAPLE FOODS

FOR COFFEE; ARTIFICIAL COFFEE; COFFEE SUBSTITUTES; COFFEE BEVERAGES WITH MILK; UNROASTED COFFEE; COFFEE-BASED BEVERAGES; COCOA; COCOA-BASED BEVERAGES; COCOA PRODUCTS, NAMELY, COCOA POWDER, COCOA SPREADS AND COCOA MIXES; COCOA BEVERAGES WITH MILK; CHOCOLATE; CHOCOLATE BEVERAGES WITH MILK; CHOCOLATE-BASED BEVERAGES; TEA; TEA-BASED BEVERAGES; ICED TEA; SHERBETS ICES; ICE CREAM; HONEY; PASTRIES; PIES; COFFEE-BASED FOOD FLAVORINGS; SUGAR; PASTA; PANCAKES; NOODLES; DESSERT PUDDINGS; PIZZAS; POPCORN; CRACKERS; CUSTARD; COOKIES; CORN FLAKES; BISCUITS; BREAD; BUNS; CAKES; SANDWICHES; SPAGHETTI; TACOS; CANDY; SPICES; WAFFLES; AROMATIC SPICES FOR FOOD; DRESSINGS FOR SALAD; PRETZELS; BAGELS (U.S. CL. 46).

FIRST USE 12-15-1999; IN COMMERCE 12-1-2010.

MARGERY A. TIERNEY, EXAMINING ATTORNEY

SN 85-362,033. C & F FOODS, INC., CITY OF INDUSTRY, CA.
FILED 7-1-2011.

NATURE'S WILD GRAINS

THE MARK CONSISTS OF STANDARD CHARACTERS WITHOUT CLAIM TO ANY PARTICULAR FONT, STYLE, SIZE, OR COLOR.

NO CLAIM IS MADE TO THE EXCLUSIVE RIGHT TO USE "WILD GRAINS", APART FROM THE MARK AS SHOWN.

CLASS 29—MEATS AND PROCESSED FOODS

FOR AGRICULTURAL PRODUCTS, NAMELY, DRIED BEANS (U.S. CL. 46).

CLASS 30—STAPLE FOODS

FOR RICE MADE FROM WILD GRAINS (U.S. CL. 46).
ALICIA COLLINS, EXAMINING ATTORNEY

SN 85-363,537. ENGINEERING SYSTEMS INC., AURORA, IL. FILED 7-5-2011.



OWNER OF U.S. REG. NOS. 3,991,330, 4,025,000 AND OTHERS.

THE MARK CONSISTS OF AN OPEN BOX GRID WITH AN UPWARD WAVY LINE THAT BEGINS AT A POINT AND GETS THICKER AS IT PROGRESSES FROM BOTTOM LEFT TO TOP RIGHT AND ENDS IN A ROUNDED TIP WITH THE WORDS "ESI" IN STYLIZED FORMAT IN THE LOWER RIGHT CORNER.

CLASS 42—SCIENTIFIC AND COMPUTER SERVICES

FOR TECHNICAL CONSULTATION IN THE FIELD OF ENGINEERING; SCIENTIFIC AND ENGINEERING RESEARCH SERVICES FOR OTHERS; TECHNICAL CONSULTATION AND SCIENTIFIC RESEARCH RELATED TO THE INVESTIGATION, ANALYSIS AND PREVENTION OF ENGINEERING AND SCIENTIFIC MATERIALS, PERFORMANCE OR DESIGN FAILURES; SCIENTIFIC RESEARCH AND TECHNICAL CONSULTATION IN THE FIELD OF PRODUCT DEVELOPMENT RELATED TO CONSUMER GOODS; AND CONSUMER PRODUCT SAFETY TESTING AND CONSULTATION (U.S. CLS. 100 AND 101).

FIRST USE 9-1-2010. THE MARK WAS FIRST USED ANYWHERE IN A DIFFERENT FORM OTHER THAN THAT SOUGHT TO BE REGISTERED AT LEAST AS EARLY AS 03/01/2001; IN COMMERCE 9-30-2010. THE MARK WAS FIRST USED IN COMMERCE IN A DIFFERENT FORM OTHER THAN THAT SOUGHT TO BE REGISTERED AT LEAST AS EARLY AS 03/01/2001.

CLASS 45—PERSONAL AND LEGAL SERVICES

FOR TECHNICAL CONSULTATION IN THE FIELD OF REGULATORY COMPLIANCE (U.S. CLS. 100 AND 101).

FIRST USE 9-1-2010; IN COMMERCE 9-30-2010.
TRACY WHITTAKER-BROWN, EXAMINING ATTORNEY

SN 85-363,839. HEWLETT-PACKARD DEVELOPMENT COMPANY, L.P., HOUSTON, TX. FILED 7-6-2011.

PIVOT

THE MARK CONSISTS OF STANDARD CHARACTERS WITHOUT CLAIM TO ANY PARTICULAR FONT, STYLE, SIZE, OR COLOR.

CLASS 9—ELECTRICAL AND SCIENTIFIC APPARATUS

FOR DOWNLOADABLE ELECTRONIC PUBLICATIONS, NAMELY, ARTICLES IN THE FIELD OF MOBILE APPLICATIONS (U.S. CLS. 21, 23, 26, 36 AND 38).

CLASS 41—EDUCATION AND ENTERTAINMENT

FOR PROVIDING ONLINE NON-DOWNLOADABLE PUBLICATIONS IN THE NATURE OF ARTICLES IN THE FIELD OF MOBILE APPLICATIONS (U.S. CLS. 100, 101 AND 107).

LAURIE MAYES, EXAMINING ATTORNEY

SN 85-365,062. PAUL STUART, INC., NEW YORK, NY. FILED 7-7-2011.

STUART II BY PAUL STUART

THE MARK CONSISTS OF STANDARD CHARACTERS WITHOUT CLAIM TO ANY PARTICULAR FONT, STYLE, SIZE, OR COLOR.

OWNER OF U.S. REG. NOS. 994,756, 1,176,308 AND 3,408,400.

THE NAME "PAUL STUART" DOES NOT IDENTIFY A LIVING INDIVIDUAL.

CLASS 18—LEATHER GOODS

FOR PURSES; BAGS FOR SPORTS; BUSINESS AND CREDIT CARD CASES; HANDBAGS; OPERA BAGS; BOSTON BAGS; POUCHES; WALLETS; TRAVEL BAGS; ATTACHE CASES; CARD CASES; UMBRELLAS; UNFITTED BAGS FOR TOILETRY KITS SOLD EMPTY; LUGGAGE; LEATHER KEY CHAINS; SACKS OF LEATHER FOR PACKAGING; CANES; PARASOLS; WALKING STICKS (U.S. CLS. 1, 2, 3, 22 AND 41).

CLASS 25—CLOTHING

FOR UNIFORMS; FOOTWEAR; SHOES; OUTER CLOTHING, NAMELY, COATS, AND COATS AND JACKETS MADE OF LEATHER AND SUEDE; GOLF WEAR, NAMELY, GOLF SHIRTS, GOLF RAINWEAR, GOLF SHOES; MEN'S WEARING APPAREL, NAMELY, RAINCOATS, AND WOMEN'S WEARING APPAREL, NAMELY, RAINCOATS, DRESSES, SKIRTS, SHOES, SANDALS, BOOTS AND HATS; NECK WEAR; BODY SHIRTS; UNDER SHIRTS; SWEAT SHIRTS; SPORT SHIRTS; UNDERPANTS; SHORTS; DRESS SHIRTS; POLO SHIRTS; T-SHIRTS; SWEATERS; BELTS; SUSPENDERS; SCARVES; GLOVES; MITTENS; HATS AND CAPS; SLEEPWEAR; SWIMWEAR; WALKING SHORTS; SUITS; OVERCOATS; SPORT JACKETS; VESTS; TROUSERS; RAINWEAR; NIGHT WEAR; HOSIERY; UNDERWEAR; LEATHER SHOES; LOW SHOES; LACE BOOTS; SANDALS FOR BATH; SLIPPERS FOR BATH; HALF-BOOTS; SANDALS; SLIPPERS; OVERSHOES; RAIN SHOES; BOOTS; LONG BOOTS; NECKTIES; SHAWLS; STOCKINGS; TIGHTS; SOCKS (U.S. CLS. 22 AND 39).

MICHAEL ENGEL, EXAMINING ATTORNEY

SN 85-367,288. LEDTRONICS, INC., TORRANCE, CA. FILED 7-9-2011.

CREATING THE FUTURE OF LIGHT SINCE 1983

THE MARK CONSISTS OF STANDARD CHARACTERS WITHOUT CLAIM TO ANY PARTICULAR FONT, STYLE, SIZE, OR COLOR.

NO CLAIM IS MADE TO THE EXCLUSIVE RIGHT TO USE "SINCE 1983", APART FROM THE MARK AS SHOWN.

CLASS 6—METAL GOODS

FOR METAL KEY CHAINS (U.S. CLS. 2, 12, 13, 14, 23, 25 AND 50).

CLASS 9—ELECTRICAL AND SCIENTIFIC APPARATUS

FOR ELECTRONIC LED SIGNS; LED CIRCUIT BOARDS; LED VEHICLE TRAFFIC SIGNALS; LIGHT EMITTING DIODE (LED) DISPLAYS; LIGHT EMITTING DIODES (LEDS); PORTABLE LED SAFETY LIGHTING DEVICES FOR PERSONAL USE FOR SAFETY PURPOSES (U.S. CLS. 21, 23, 26, 36 AND 38).

CLASS 11—ENVIRONMENTAL CONTROL APPARATUS

FOR LED (LIGHT EMITTING DIODE) LIGHTING FIXTURES; LED (LIGHT EMITTING DIODES) LIGHTING FIXTURES FOR USE IN DISPLAY, COMMERCIAL, INDUSTRIAL, RESIDENTIAL, AND ARCHITECTURAL ACCENT LIGHTING APPLICATIONS; LED LANDSCAPE LIGHTS; LED LIGHT APPARATUS THAT CLIPS ON TO A HANDBAG, USED TO ILLUMINATE A HANDBAG; LED LIGHT ASSEMBLIES FOR STREET LIGHTS, SIGNS, COMMERCIAL LIGHTING, AUTOMOBILES, BUILDINGS, AND OTHER ARCHITECTURAL USES; LED LIGHT BULBS; LED LIGHT MACHINES; LED LIGHTING FIXTURES FOR INDOOR AND OUTDOOR LIGHTING APPLICATIONS; LED LIGHTING SYSTEMS, NAMELY, LED MODULES, POWER SUPPLIES, AND WIRING; LED LIGHTS FOR LIGHTING PURPOSES INCORPORATED INTO KEY CHAINS, SMALL TOYS OR OTHER SIMILAR PERSONAL ITEMS; LED LIGHTS FOR STRINGS, FLOWERS, BRANCHES AND OTHER ORNAMENTAL DECORATIONS; LED LUMINAIRES; LIGHT EMITTING DIODE (LED) PLANT GROW LIGHT; LIGHTS FOR USE IN ILLUMINATING SIGNS AND DISPLAYS; LUMINAIRES, USING LIGHT EMITTING DIODES (LEDS) AS A LIGHT SOURCE, FOR STREET OR ROADWAY LIGHTING; OPTICAL LENS COVERS THAT IMPROVE LIGHT OUTPUT AND UNIFORMITY AND PROTECT THE LED, SOLD AS A FEATURE OF AN LED LIGHTING SYSTEM; TOOLS, COMPONENTS AND SUPPLIES FOR USE IN MAKING SIGNS, NAMELY, LED BULBS, LAMPS AND FIXTURES; LED STREET LIGHTS; LED STREET LIGHT BULBS; LED TUBE LIGHTS; LED TUBE LIGHT BULBS; LED TUBE LIGHT FIXTURES (U.S. CLS. 13, 21, 23, 31 AND 34).

CLASS 40—MATERIAL TREATMENT

FOR CUSTOM MANUFACTURE OF LIGHT EMITTING DIODE (LED) DEVICES; MANUFACTURE OF LIGHT EMITTING DIODE (LED) DEVICES, NAMELY, ARRAYS, CLUSTERS AND DISPLAYS OF LED DEVICES FOR INSTRUMENTATION, INDICATION AND ILLUMINATION WITHIN THE VISIBLE LIGHT AND INFRARED SPECTRUM TO ORDER AND/OR SPECIFICATION OF OTHERS (U.S. CLS. 100, 103 AND 106).

SN 85-366,495. ENGINEERING SYSTEMS INC., AURORA, IL. FILED 7-8-2011.



OWNER OF U.S. REG. NOS. 3,991,330, 4,025,000 AND OTHERS.

NO CLAIM IS MADE TO THE EXCLUSIVE RIGHT TO USE "ENGINEERING AND SCIENTIFIC INVESTIGATION", APART FROM THE MARK AS SHOWN.

THE MARK CONSISTS OF AN OPEN BOX GRID WITH AN UPWARD WAVY LINE THAT BEGINS AT A POINT AND GETS THICKER AS IT PROGRESSES FROM BOTTOM LEFT TO TOP RIGHT AND ENDS IN A ROUNDED TIP WITH THE WORDS "ESI ENGINEERING AND SCIENTIFIC INVESTIGATION" IN STYLIZED FORMAT IN THE LOWER RIGHT CORNER.

CLASS 42—SCIENTIFIC AND COMPUTER SERVICES

FOR TECHNICAL CONSULTATION IN THE FIELD OF ENGINEERING; SCIENTIFIC AND ENGINEERING RESEARCH SERVICES FOR OTHERS; TECHNICAL CONSULTATION AND SCIENTIFIC RESEARCH RELATED TO THE INVESTIGATION, ANALYSIS AND PREVENTION OF ENGINEERING AND SCIENTIFIC MATERIALS, PERFORMANCE OR DESIGN FAILURES; SCIENTIFIC RESEARCH AND TECHNICAL CONSULTATION IN THE FIELD OF PRODUCT DEVELOPMENT RELATED TO CONSUMER GOODS; AND CONSUMER PRODUCT SAFETY TESTING AND CONSULTATION (U.S. CLS. 100 AND 101).

FIRST USE 9-1-2010; IN COMMERCE 10-31-2010.

CLASS 45—PERSONAL AND LEGAL SERVICES

FOR TECHNICAL CONSULTATION IN THE FIELD OF REGULATORY COMPLIANCE (U.S. CLS. 100 AND 101).

FIRST USE 9-1-2010; IN COMMERCE 9-30-2010.

TRACY WHITTAKER-BROWN, EXAMINING ATTORNEY

CLASS 42—SCIENTIFIC AND COMPUTER SERVICES

FOR DESIGN FOR OTHERS IN THE FIELD OF LIGHT EMITTING DIODE (LED) DEVICES, LIGHTS, DISPLAYS, ARRAYS, CLUSTERS AND FIXTURES (U.S. CLS. 100 AND 101).

C. DIONNE CLYBURN, EXAMINING ATTORNEY

SN 85-369,405. RIQUE, CHRISTI-ANN, BROOKLYN, NY. FILED 7-12-2011.

KIMMEY LEXX

THE MARK CONSISTS OF STANDARD CHARACTERS WITHOUT CLAIM TO ANY PARTICULAR FONT, STYLE, SIZE, OR COLOR.

THE NAME "KIMMEY LEXX" IDENTIFIES A PSEUDONYM/STAGE NAME/NICKNAME OF "CHRISTI-ANN RIQUE", A LIVING INDIVIDUAL WHOSE CONSENT IS OF RECORD.

CLASS 9—ELECTRICAL AND SCIENTIFIC APPARATUS

FOR PRE-RECORDED CDS FEATURING MUSIC; PRE-RECORDED DIGITAL MEDIA FEATURING MUSIC AND PRE-RECORDED DIGITAL MEDIA FEATURING AUDIO VISUAL WORKS CONTAINING MUSICAL VIDEOS AND MUSICAL PERFORMANCES; PRE-RECORDED ELECTRONIC AND DIGITAL MEDIA FEATURING MUSIC AND VIDEO RECORDINGS FEATURING MUSIC VIDEOS AND MUSICAL PERFORMANCES (U.S. CLS. 21, 23, 26, 36 AND 38).

CLASS 41—EDUCATION AND ENTERTAINMENT

FOR ENTERTAINMENT IN THE NATURE OF LIVE PERFORMANCES BY AN INDIVIDUAL FEATURING MUSIC; ENTERTAINMENT SERVICES IN THE NATURE OF LIVE MUSICAL PERFORMANCES (U.S. CLS. 100, 101 AND 107).

KATHLEEN M. VANSTON, EXAMINING ATTORNEY

SN 85-369,695. SALT TABLE LLC, SAVANNAH, GA. FILED 7-12-2011.

the salt table

THE MARK CONSISTS OF STANDARD CHARACTERS WITHOUT CLAIM TO ANY PARTICULAR FONT, STYLE, SIZE, OR COLOR.

NO CLAIM IS MADE TO THE EXCLUSIVE RIGHT TO USE "SALT", APART FROM THE MARK AS SHOWN.

CLASS 30—STAPLE FOODS

FOR FOOD FLAVORINGS; POPCORN; SALT; SPICE BLENDS; SPICES; TEA; VANILLA; VINEGAR (U.S. CL. 46).

FIRST USE 12-1-2009; IN COMMERCE 12-1-2009.

CLASS 35—ADVERTISING AND BUSINESS

FOR RETAIL STORE AND ON-LINE RETAIL STORE SERVICES FEATURING SALTS, SPICES, TEAS, FOOD OILS, BLENDS, VANILLAS, VINEGARS, AND POPCORN (U.S. CLS. 100, 101 AND 102).

FIRST USE 12-1-2009; IN COMMERCE 12-1-2009.

WILLIAM BRECKENFELD, EXAMINING ATTORNEY

SN 85-369,940. SUMITOMO ELECTRIC INDUSTRIES, LTD., OSAKA-SHI, OSAKA, JAPAN, FILED 7-13-2011.

Geocloid

THE MARK CONSISTS OF STANDARD CHARACTERS WITHOUT CLAIM TO ANY PARTICULAR FONT, STYLE, SIZE, OR COLOR.

OWNER OF JAPAN REG. NO. 5450615, DATED 11-11-2011, EXPIRES 11-11-2021.

CLASS 7—MACHINERY

FOR OIL PUMP ROTORS AS PARTS OF MOTORS AND ENGINES (U.S. CLS. 13, 19, 21, 23, 31, 34 AND 35).

CLASS 12—VEHICLES

FOR VEHICLE TRANSMISSION COMPONENTS, NAMELY, OIL PUMP ROTORS (U.S. CLS. 19, 21, 23, 31, 35 AND 44).

MARK SHINER, EXAMINING ATTORNEY

SN 85-371,616. PHILADELPHIA UNIVERSITY, PHILADELPHIA, PA. FILED 7-14-2011.

PHILAU

THE MARK CONSISTS OF STANDARD CHARACTERS WITHOUT CLAIM TO ANY PARTICULAR FONT, STYLE, SIZE, OR COLOR.

CLASS 16—PAPER GOODS AND PRINTED MATTER

FOR DECALS, PAPER COASTERS, PAPER NAPKINS, BALL POINT AND FOUNTAIN PENS, LEAD PENCILS, STATIONERY, FILE FOLDERS, NOTEBOOKS, LOOSE LEAF BINDERS, SCHOOL YEARBOOKS, SCHOOL DIRECTORIES AND POSTCARDS (U.S. CLS. 2, 5, 22, 23, 29, 37, 38 AND 50).

CLASS 18—LEATHER GOODS

FOR UMBRELLAS; BACKPACKS, BOOK BAGS, AND SPORTS BAGS (U.S. CLS. 1, 2, 3, 22 AND 41).

CLASS 21—HOUSEWARES AND GLASS

FOR DRINKING GLASSES, MUGS, CUPS; DECORATIVE PLATES; COASTERS NOT OF PAPER AND NOT BEING TABLE LINEN; INSULATION SLEEVE HOLDERS FOR CANNED AND BOTTLED DRINKS; SERVING TRAYS NOT OF PRECIOUS METAL; AND WASTEBASKETS (U.S. CLS. 2, 13, 23, 29, 30, 33, 40 AND 50).

CLASS 25—CLOTHING

FOR CLOTHING, NAMELY, DECORATIVE T-SHIRTS, SWEATERS, JACKETS, SWEATSHIRTS, SWEATPANTS, SHORTS, TIES, CAPS, HATS, SUN VISORS, HEADBANDS, WRISTBANDS, SOCKS, RAIN PONCHOS, BELTS AND SUSPENDERS (U.S. CLS. 22 AND 39).
TINA L. SNAPP, EXAMINING ATTORNEY

SN 85-371,716. PHILADELPHIA UNIVERSITY, PHILADELPHIA, PA. FILED 7-14-2011.

POWERED TO DO

THE MARK CONSISTS OF STANDARD CHARACTERS WITHOUT CLAIM TO ANY PARTICULAR FONT, STYLE, SIZE, OR COLOR.
OWNER OF U.S. REG. NO. 3,563,820.

CLASS 16—PAPER GOODS AND PRINTED MATTER

FOR DECALS, PAPER COASTERS, PAPER NAPKINS, BALL POINT AND FOUNTAIN PENS, LEAD PENCILS, STATIONERY, FILE FOLDERS, NOTEBOOKS, LOOSE LEAF BINDERS, SCHOOL YEARBOOKS, SCHOOL DIRECTORIES AND POSTCARDS (U.S. CLS. 2, 5, 22, 23, 29, 37, 38 AND 50).

CLASS 18—LEATHER GOODS

FOR UMBRELLAS; BACKPACKS, BOOK BAGS, AND SPORTS BAGS (U.S. CLS. 1, 2, 3, 22 AND 41).

CLASS 21—HOUSEWARES AND GLASS

FOR DRINKING GLASSES, MUGS, CUPS; DECORATIVE PLATES; COASTERS NOT OF PAPER AND NOT BEING TABLE LINEN; INSULATION SLEEVE HOLDERS FOR CANNED AND BOTTLED DRINKS; SERVING TRAYS NOT OF PRECIOUS METAL; AND WASTEBASKETS (U.S. CLS. 2, 13, 23, 29, 30, 33, 40 AND 50).

CLASS 25—CLOTHING

FOR CLOTHING, NAMELY, DECORATIVE T-SHIRTS, SWEATERS, JACKETS, SWEATSHIRTS, SWEATPANTS, SHORTS, TIES, CAPS, HATS, SUN VISORS, HEADBANDS, WRISTBANDS, SOCKS, RAIN PONCHOS, BELTS AND SUSPENDERS (U.S. CLS. 22 AND 39).
TINA L. SNAPP, EXAMINING ATTORNEY

SN 85-371,724. PHILADELPHIA UNIVERSITY, PHILADELPHIA, PA. FILED 7-14-2011.

**POWERED TO DO WHAT'S NOW,
POWERED TO DO WHAT'S NEXT**

THE MARK CONSISTS OF STANDARD CHARACTERS WITHOUT CLAIM TO ANY PARTICULAR FONT, STYLE, SIZE, OR COLOR.

CLASS 16—PAPER GOODS AND PRINTED MATTER

FOR DECALS, PAPER COASTERS, PAPER NAPKINS, BALL POINT AND FOUNTAIN PENS, LEAD PENCILS, STATIONERY, FILE FOLDERS, NOTEBOOKS, LOOSE LEAF BINDERS, SCHOOL YEARBOOKS, SCHOOL DIRECTORIES AND POSTCARDS (U.S. CLS. 2, 5, 22, 23, 29, 37, 38 AND 50).

CLASS 18—LEATHER GOODS

FOR UMBRELLAS; BACKPACKS, BOOK BAGS, AND SPORTS BAGS (U.S. CLS. 1, 2, 3, 22 AND 41).

CLASS 21—HOUSEWARES AND GLASS

FOR DRINKING GLASSES, MUGS, CUPS; DECORATIVE PLATES; COASTERS NOT OF PAPER AND NOT BEING TABLE LINEN; INSULATION SLEEVE HOLDERS FOR CANNED AND BOTTLED DRINKS; SERVING TRAYS NOT OF PRECIOUS METAL; AND WASTEBASKETS (U.S. CLS. 2, 13, 23, 29, 30, 33, 40 AND 50).

CLASS 25—CLOTHING

FOR CLOTHING, NAMELY, DECORATIVE T-SHIRTS, SWEATERS, JACKETS, SWEATSHIRTS, SWEATPANTS, SHORTS, TIES, CAPS, HATS, SUN VISORS, HEADBANDS, WRISTBANDS, SOCKS, RAIN PONCHOS, BELTS AND SUSPENDERS (U.S. CLS. 22 AND 39).
TINA L. SNAPP, EXAMINING ATTORNEY

SN 85-371,740. TRULITE GLASS & ALUMINUM SOLUTIONS, LLC, TAMARAC, FL. FILED 7-14-2011.

GLASS & ALUMINUM SOLUTIONS

NO CLAIM IS MADE TO THE EXCLUSIVE RIGHT TO USE "GLASS & ALUMINUM SOLUTIONS", APART FROM THE MARK AS SHOWN.

THE MARK CONSISTS OF A DOUBLE "V" DESIGN FOLLOWED BY THE WORDS "TRULITE GLASS & ALUMINUM SOLUTIONS".

CLASS 6—METAL GOODS

FOR METAL BUILDING PRODUCTS, NAMELY, GLASS FRAMING SYSTEMS, CONSISTING PRIMARILY OF SPACER BARS, CURTAIN WALLS, ENTRANCE DOORS AND WINDOWS, FRAMES AND MULLIONS FOR USE IN RESIDENTIAL, RETAIL, INDUSTRIAL AND COMMERCIAL BUILDINGS, STOREFRONTS AND ENTRANCEWAYS (U.S. CLS. 2, 12, 13, 14, 23, 25 AND 50).

HOWARD B. LEVINE, EXAMINING ATTORNEY

SN 85-373,025. SMART PLANET TECHNOLOGIES, INC., IRVINE, CA. FILED 7-15-2011.

CLASS 19—NON-METALLIC BUILDING MATERIALS

FOR BUILDING MATERIALS AND ARCHITECTURAL PRODUCTS, NAMELY, COMMON SHEET GLASS, LAMINATED FLAT GLASS, WIRE GLASS, NAMELY, A SAFETY GLASS WITH REINFORCING METAL WIRE, INSULATED GLASS, HEAT-TREATED GLASS, NON-METAL SPANDREL, GLASS HANDRAILS, CLAD AND GLASS DOORS (U.S. CLS. 1, 12, 33 AND 50).

EARTHDISPLAY

THE MARK CONSISTS OF STANDARD CHARACTERS WITHOUT CLAIM TO ANY PARTICULAR FONT, STYLE, SIZE, OR COLOR.

CLASS 35—ADVERTISING AND BUSINESS

FOR DISTRIBUTORSHIP SERVICES IN THE FIELD OF GLASS, METAL AND NON-METAL GLASS-RELATED PRODUCTS AND METAL AND NON-METAL ARCHITECTURAL PRODUCTS (U.S. CLS. 100, 101 AND 102).

CLASS 16—PAPER GOODS AND PRINTED MATTER

FOR PANELS MADE OF COMPOSITE MATERIAL CONTAINING PRIMARILY PAPER AND MINERALS FOR APPLICATION OF PRINTED MEDIA FOR USE IN SIGNAGE APPLICATIONS (U.S. CLS. 2, 5, 22, 23, 29, 37, 38 AND 50).

CLASS 37—CONSTRUCTION AND REPAIR

FOR INSTALLATION OF CUSTOM SKYLIGHT SYSTEMS, COMMERCIAL AND RESIDENTIAL GLASS PRODUCTS (U.S. CLS. 100, 103 AND 106).

CLASS 17—RUBBER GOODS

FOR PACKAGING MATERIAL MADE FROM MINERAL-BASED PLASTIC SUBSTITUTES (U.S. CLS. 1, 5, 12, 13, 35 AND 50).

CLASS 40—MATERIAL TREATMENT

FOR MANUFACTURING OF BUILDING PRODUCTS FOR OTHERS, NAMELY, ALUMINUM FRAMING SYSTEMS FOR GLASS, STOREFRONTS, CURTAIN WALLS, DOORS AND WINDOWS FOR OTHERS; FABRICATION OF GLASS PRODUCTS FOR OTHERS, NAMELY, INSULATED, LAMINATED, TEMPERED, DECORATIVE, BULLET AND BLAST RESISTANT GLASS, AND MIRRORS (U.S. CLS. 100, 103 AND 106).

AMY HELLA, EXAMINING ATTORNEY

TINA MAI, EXAMINING ATTORNEY

SN 85-374,748. S.D. WARREN COMPANY, BOSTON, MA. FILED 7-19-2011.

SN 85-372,879. CLARENCE L. SMITH II, DBA ACTIVE FAITH SPORTS, MISSOURI CITY, TX. FILED 7-15-2011.

In Jesus Name I Play**OFF REGISTER**

THE MARK CONSISTS OF STANDARD CHARACTERS WITHOUT CLAIM TO ANY PARTICULAR FONT, STYLE, SIZE, OR COLOR.

THE MARK CONSISTS OF STANDARD CHARACTERS WITHOUT CLAIM TO ANY PARTICULAR FONT, STYLE, SIZE, OR COLOR.

CLASS 14—JEWELRY

FOR RUBBER OR SILICON WRISTBANDS IN THE NATURE OF A BRACELET (U.S. CLS. 2, 27, 28 AND 50). FIRST USE 1-30-2010; IN COMMERCE 2-15-2010.

CLASS 16—PAPER GOODS AND PRINTED MATTER

FOR PRINTED MATERIALS, NAMELY, BROCHURES IN THE FIELDS OF PAPER AND PRINTING (U.S. CLS. 2, 5, 22, 23, 29, 37, 38 AND 50). FIRST USE 3-8-2011; IN COMMERCE 3-8-2011.

CLASS 25—CLOTHING

FOR ATHLETIC APPAREL, NAMELY, SHIRTS, PANTS, JACKETS, FOOTWEAR, HATS AND CAPS, ATHLETIC UNIFORMS; HOODED SWEATSHIRTS; MOISTURE-WICKING SPORTS PANTS; MOISTURE-WICKING SPORTS SHIRTS; TRACK PANTS; WRISTBANDS; YOGA PANTS (U.S. CLS. 22 AND 39). FIRST USE 1-30-2010; IN COMMERCE 4-15-2010.

CLASS 40—MATERIAL TREATMENT

FOR PROVIDING A WEBSITE FEATURING NON-DOWNLOADABLE VIDEOS IN THE FIELDS OF MANUFACTURING OF PAPER, THE PRINTING PROCESS OF PAPER AND PRINTING (U.S. CLS. 100, 103 AND 106). FIRST USE 10-27-2010; IN COMMERCE 11-19-2010.

CLASS 41—EDUCATION AND ENTERTAINMENT

FOR PRODUCTION OF HUMOROUS VIDEOS FOR THE INTERNET; PRODUCTION AND DISTRIBUTION OF VIDEOS IN THE FIELDS OF MANUFACTURING OF PAPER, THE PRINTING PROCESS OF PAPER AND PRINTING (U.S. CLS. 100, 101 AND 107).

FIRST USE 10-27-2010; IN COMMERCE 11-19-2010.
KEVON CHISOLM, EXAMINING ATTORNEY

SN 85-378,628. PORTER, HEATHER, DUBAI, UNITED ARAB EMIR., FILED 7-22-2011.

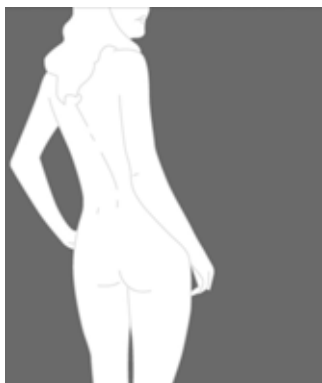

THE MARK CONSISTS OF A GRAPHIC IMAGE OF A BACK OF A WOMAN'S BODY.

CLASS 3—COSMETICS AND CLEANING PREPARATIONS

FOR SKIN AND FACE CREAMS AND LOTIONS (U.S. CLS. 1, 4, 6, 50, 51 AND 52).

CLASS 16—PAPER GOODS AND PRINTED MATTER

FOR BOOKS IN THE FIELD OF HEALTH AND FITNESS (U.S. CLS. 2, 5, 22, 23, 29, 37, 38 AND 50).

CLASS 41—EDUCATION AND ENTERTAINMENT

FOR ENTERTAINMENT SERVICES, NAMELY, PROVIDING ON-GOING TELEVISION PROGRAMS IN THE FIELD OF HEALTH AND FITNESS (U.S. CLS. 100, 101 AND 107).

DOMINIC FATHY, EXAMINING ATTORNEY

SN 85-378,706. PETROTECHNICAL DATA SYSTEMS AMERICAN HOLDING LLC, ZUID HOLLAND, NETHERLANDS, FILED 7-22-2011.

DRILLING ENTERPRISE

THE MARK CONSISTS OF STANDARD CHARACTERS WITHOUT CLAIM TO ANY PARTICULAR FONT, STYLE, SIZE, OR COLOR.

NO CLAIM IS MADE TO THE EXCLUSIVE RIGHT TO USE "DRILLING", APART FROM THE MARK AS SHOWN.

CLASS 9—ELECTRICAL AND SCIENTIFIC APPARATUS

FOR COMPUTER SOFTWARE FOR ACCESSING INFORMATION DIRECTORIES THAT MAY BE DOWNLOADED FROM A GLOBAL COMPUTER NETWORK; COMPUTER SOFTWARE FOR DATA MANAGEMENT IN THE OIL AND GAS PRODUCTION SECTOR THAT MAY BE DOWNLOADED FROM A GLOBAL COMPUTER NETWORK; DOWNLOADABLE SOFTWARE FOR DATA MANAGEMENT IN THE OIL AND GAS PRODUCTION SECTOR; ELECTRONIC SOFTWARE UPDATES, NAMELY, DOWNLOADABLE COMPUTER SOFTWARE AND ASSOCIATED DATA FILES FOR UPDATING COMPUTER SOFTWARE IN THE FIELDS OF DATA MANAGEMENT IN THE OIL AND GAS PRODUCTION SECTOR, PROVIDED VIA COMPUTER AND COMMUNICATION NETWORKS (U.S. CLS. 21, 23, 26, 36 AND 38).

CLASS 42—SCIENTIFIC AND COMPUTER SERVICES

FOR PROVIDING NON-DOWNLOADABLE ONLINE COMPUTER SOFTWARE FOR CREATING WORKFLOW SOLUTIONS; PROVIDING NON-DOWNLOADABLE ONLINE COMPUTER SOFTWARE FOR ACCESSING INFORMATION DIRECTORIES; PROVIDING NON-DOWNLOADABLE ONLINE COMPUTER SOFTWARE FOR DATA MANAGEMENT IN THE OIL AND GAS PRODUCTION SECTOR (U.S. CLS. 100 AND 101).

BRIAN NEVILLE, EXAMINING ATTORNEY

SN 85-380,255. NATOLI ENGINEERING COMPANY, INC., ST. CHARLES, MO. FILED 7-25-2011.

NATOLI

THE MARK CONSISTS OF STANDARD CHARACTERS WITHOUT CLAIM TO ANY PARTICULAR FONT, STYLE, SIZE, OR COLOR.
SEC. 2(F).

CLASS 35—ADVERTISING AND BUSINESS

FOR DISTRIBUTORSHIPS AND ONLINE RETAIL STORE SERVICES IN THE FIELD OF TABLET COMPRESSION TOOLING FOR PHARMACEUTICAL, NUTRITIONAL, CONFECTIONARY, INDUSTRIAL AND VETERINARY INDUSTRIES (U.S. CLS. 100, 101 AND 102).

FIRST USE 0-0-1973; IN COMMERCE 0-0-1973.

CLASS 37—CONSTRUCTION AND REPAIR

FOR TECHNICAL SUPPORT AND TROUBLESHOOTING IN THE FIELD OF TABLET COMPRESSION TOOLING REPAIR AND INSTALLATION FOR PHARMACEUTICAL, NUTRITIONAL, CONFECTIONARY, INDUSTRIAL AND VETERINARY INDUSTRIES (U.S. CLS. 100, 103 AND 106).

FIRST USE 0-0-1973; IN COMMERCE 0-0-1973.

CLASS 41—EDUCATION AND ENTERTAINMENT

FOR TECHNICAL TRAINING IN THE FIELD OF TABLET COMPRESSION TOOLING FOR PHARMACEUTICAL, NUTRITIONAL, CONFECTIONARY, INDUSTRIAL AND VETERINARY INDUSTRIES (U.S. CLS. 100, 101 AND 107).

FIRST USE 0-0-1973; IN COMMERCE 0-0-1973.

CLASS 42—SCIENTIFIC AND COMPUTER SERVICES

FOR TECHNICAL SUPPORT AND TROUBLESHOOTING IN THE FIELD OF SOFTWARE RELATING TO TABLET COMPRESSION TOOLING FOR PHARMACEUTICAL, NUTRITIONAL, CONFECTIONARY, INDUSTRIAL AND VETERINARY INDUSTRIES (U.S. CLS. 100 AND 101).

FIRST USE 0-0-1993; IN COMMERCE 0-0-1993.
JANET LEE, EXAMINING ATTORNEY

SN 85-381,891. THE NEW TEACHER PROJECT, INC., BROOKLYN, NY. FILED 7-27-2011.

TNTP

THE MARK CONSISTS OF STANDARD CHARACTERS WITHOUT CLAIM TO ANY PARTICULAR FONT, STYLE, SIZE, OR COLOR.

SN 85-381,395. UNIVERSITH OF NAVARRA, BARCELONA, SPAIN, FILED 7-26-2011.

**IME INSTITUTE FOR MEDIA
AND ENTERTAINMENT**

THE MARK CONSISTS OF STANDARD CHARACTERS WITHOUT CLAIM TO ANY PARTICULAR FONT, STYLE, SIZE, OR COLOR.

NO CLAIM IS MADE TO THE EXCLUSIVE RIGHT TO USE "INSTITUTE" FOR INTERNATIONAL CLASS 41, APART FROM THE MARK AS SHOWN.

SEC. 2(F) AS TO "INSTITUTE FOR MEDIA AND ENTERTAINMENT".

CLASS 9—ELECTRICAL AND SCIENTIFIC APPARATUS

FOR ELECTRONIC PUBLICATIONS, NAMELY, DOWNLOADABLE RESEARCH PAPERS, REPORTS, ARTICLES AND BOOKS ALL IN THE FIELDS OF BUSINESS MANAGEMENT AND ADMINISTRATION, ACCOUNTING, BUSINESS ETHICS, ECONOMICS, INFORMATION TECHNOLOGIES, AND BUSINESS STRATEGY RELATING TO MEDIA AND ENTERTAINMENT (U.S. CLS. 21, 23, 26, 36 AND 38).

FIRST USE 1-1-2004; IN COMMERCE 1-1-2004.

CLASS 16—PAPER GOODS AND PRINTED MATTER

FOR PUBLICATIONS AND INSTRUCTIONAL AND TEACHING MATERIALS, NAMELY, RESEARCH PAPERS, REPORTS, ARTICLES AND BOOKS, ALL IN THE FIELDS OF BUSINESS MANAGEMENT AND ADMINISTRATION, ACCOUNTING, BUSINESS ETHICS, ECONOMICS, INFORMATION TECHNOLOGIES, AND BUSINESS STRATEGY RELATING TO MEDIA AND ENTERTAINMENT (U.S. CLS. 2, 5, 22, 23, 29, 37, 38 AND 50).

FIRST USE 1-1-2004; IN COMMERCE 1-1-2004.

CLASS 41—EDUCATION AND ENTERTAINMENT

FOR EDUCATIONAL SERVICES, NAMELY, ARRANGING AND CONDUCTING COURSE COLLOQUIUMS, CONFERENCES, SEMINARS, WORKSHOPS AND POST GRADUATE COURSES ALL IN THE FIELDS OF BUSINESS MANAGEMENT AND ADMINISTRATION, ACCOUNTING, BUSINESS ETHICS, ECONOMICS, INFORMATION TECHNOLOGIES, AND BUSINESS STRATEGY RELATING TO MEDIA AND ENTERTAINMENT (U.S. CLS. 100, 101 AND 107).

FIRST USE 1-1-2004; IN COMMERCE 1-1-2004.
JULIE GUTTADAURO, EXAMINING ATTORNEY

CLASS 35—ADVERTISING AND BUSINESS

FOR EMPLOYMENT SERVICES, NAMELY, RECRUITING INDIVIDUALS TO TEACH CLASSES IN PRIMARY AND SECONDARY PUBLIC SCHOOLS IN THE FIELDS OF READING, WRITING, SPELLING, GRAMMAR, LANGUAGES, GEOGRAPHY, SOCIAL STUDIES, MATHEMATICS, SCIENCE, NUTRITION, HEALTH, PHYSICAL EDUCATION, COMPUTER AND INFORMATION TECHNOLOGY, MUSIC, ART AND LITERATURE; CONSULTING SERVICES PROVIDED TO PRIMARY AND SECONDARY PUBLIC SCHOOLS IN THE FIELD OF RECRUITING AND HIRING OF INDIVIDUALS TO TEACH CLASSES; PERSONNEL MANAGEMENT SERVICES, NAMELY, DESIGNING AND IMPLEMENTING HIGH-QUALITY TEACHER EVALUATION SYSTEMS AND POLICIES AND PRACTICES TO MANAGE TEACHER PERFORMANCE AT THE STATE, DISTRICT AND SCHOOL LEVELS, CONDUCTING RESEARCH ON PROCESSES THAT UNDERMINE A STRONG TEACHER WORKFORCE, AND DEVELOPING TOOLS AND SYSTEMS TO ADVANCE AND SUPPORT EFFECTIVE TEACHING (U.S. CLS. 100, 101 AND 102).

CLASS 41—EDUCATION AND ENTERTAINMENT

FOR PROVIDING TRAINING IN THE FIELD OF PERSONNEL MANAGEMENT TO IMPLEMENT HIGH-QUALITY TEACHER EVALUATION SYSTEMS AND POLICIES AND PRACTICES TO MANAGE TEACHER PERFORMANCE; EDUCATIONAL SERVICES, NAMELY, TRAINING INDIVIDUALS TO TEACH CLASSES IN PRIMARY AND SECONDARY PUBLIC SCHOOLS IN THE FIELDS OF READING, WRITING, SPELLING, GRAMMAR, LANGUAGES, GEOGRAPHY, SOCIAL STUDIES, MATHEMATICS, SCIENCE, NUTRITION, HEALTH, PHYSICAL EDUCATION, COMPUTER AND INFORMATION TECHNOLOGY, MUSIC, ART AND LITERATURE; CONSULTING SERVICES PROVIDED TO PRIMARY AND SECONDARY PUBLIC SCHOOLS IN THE FIELD OF TRAINING INDIVIDUALS TO TEACH CLASSES (U.S. CLS. 100, 101 AND 107).

CURTIS FRENCH, EXAMINING ATTORNEY

SN 85-381,895. THE NEW TEACHER PROJECT, INC., BROOKLYN, NY. FILED 7-27-2011.

THE NEW TEACHER PROJECT

THE MARK CONSISTS OF STANDARD CHARACTERS WITHOUT CLAIM TO ANY PARTICULAR FONT, STYLE, SIZE, OR COLOR.

OWNER OF U.S. REG. NO. 3,467,854.
SEC. 2(F).

CLASS 35—ADVERTISING AND BUSINESS

FOR PERSONNEL MANAGEMENT SERVICES, NAMELY, DESIGNING AND IMPLEMENTING HIGH-QUALITY TEACHER EVALUATION SYSTEMS AND POLICIES AND PRACTICES TO MANAGE TEACHER PERFORMANCE AT THE STATE, DISTRICT AND SCHOOL LEVELS, CONDUCTING RESEARCH ON PROCESSES THAT UNDERMINE A STRONG TEACHER WORKFORCE, AND DEVELOPING TOOLS AND SYSTEMS TO ADVANCE AND SUPPORT EFFECTIVE TEACHING (U.S. CLS. 100, 101 AND 102).

FIRST USE 1-1-2010; IN COMMERCE 1-1-2010.

CLASS 41—EDUCATION AND ENTERTAINMENT

FOR PROVIDING TRAINING IN THE FIELD OF PERSONNEL MANAGEMENT TO IMPLEMENT HIGH-QUALITY TEACHER EVALUATION SYSTEMS AND POLICIES AND PRACTICES TO MANAGE TEACHER PERFORMANCE (U.S. CLS. 100, 101 AND 107).

FIRST USE 1-1-2010; IN COMMERCE 1-1-2010.
CURTIS FRENCH, EXAMINING ATTORNEY

SN 85-382,512. SAM BROWN SALES COMPANY, SOUTH-FIELD, MI. FILED 7-27-2011.

DEXTATRON

THE MARK CONSISTS OF STANDARD CHARACTERS WITHOUT CLAIM TO ANY PARTICULAR FONT, STYLE, SIZE, OR COLOR.

CLASS 9—ELECTRICAL AND SCIENTIFIC APPARATUS

FOR DISPOSABLE PROTECTIVE PLASTIC GLOVES FOR LABORATORY USE (U.S. CLS. 21, 23, 26, 36 AND 38).

FIRST USE 7-13-2011; IN COMMERCE 7-13-2011.

CLASS 10—MEDICAL APPARATUS

FOR DENTAL GLOVES (U.S. CLS. 26, 39 AND 44).
FIRST USE 7-13-2011; IN COMMERCE 7-13-2011.

CLASS 21—HOUSEWARES AND GLASS

FOR DISPOSABLE PLASTIC GLOVES FOR HOME USE AND DISPOSABLE PLASTIC GLOVES FOR GENERAL USE (U.S. CLS. 2, 13, 23, 29, 30, 33, 40 AND 50).

FIRST USE 7-13-2011; IN COMMERCE 7-13-2011.
DAVID C. REIHNER, EXAMINING ATTORNEY

SN 85-384,110. BLIZZARD ENTERTAINMENT, INC., IRVINE, CA. FILED 7-28-2011.

MISTS OF PANDARIA

THE MARK CONSISTS OF STANDARD CHARACTERS WITHOUT CLAIM TO ANY PARTICULAR FONT, STYLE, SIZE, OR COLOR.

CLASS 9—ELECTRICAL AND SCIENTIFIC APPARATUS

FOR COMPUTER GAME SOFTWARE; COMPUTER GAME DISCS; COMPUTER GAME SOFTWARE AND RELATED INSTRUCTION MANUALS AND GUIDES SOLD TOGETHER AS A UNIT; DOWNLOADABLE COMPUTER GAME SOFTWARE; COMPUTER GAME SOFTWARE DOWNLOADABLE FROM A GLOBAL COMPUTER NETWORK; DOWNLOADABLE ELECTRONIC GAMES VIA THE INTERNET AND WIRELESS DEVICES; INTERACTIVE MULTIMEDIA COMPUTER GAME PROGRAM; MOUSEPADS (U.S. CLS. 21, 23, 26, 36 AND 38).

CLASS 41—EDUCATION AND ENTERTAINMENT

FOR ENTERTAINMENT SERVICES, NAMELY, PROVIDING ON-LINE COMPUTER GAMES; PROVIDING COMPUTER GAMES THAT MAY BE ACCESSED VIA A GLOBAL COMPUTER NETWORK; PROVIDING ONLINE NEWS AND INFORMATION IN THE FIELD OF COMPUTER GAMES; ENTERTAINMENT SERVICES, NAMELY, CONDUCTING CONTESTS ONLINE AND PROVIDING A WEBSITE FOR ORGANIZING, PLANNING AND EXECUTING EXHIBITIONS AND SPECIAL EVENTS BETWEEN COMPUTER GAME PLAYERS AND INTEREST GROUPS FOR ENTERTAINMENT PURPOSES (U.S. CLS. 100, 101 AND 107).

ANTHONY RINKER, EXAMINING ATTORNEY

SN 85-384,655. BLACKARD, SANDRA RUTH, DBA LANGUAGE OF LISTENING, ROUND ROCK, TX. FILED 7-29-2011.

LANGUAGE OF LISTENING

THE MARK CONSISTS OF STANDARD CHARACTERS WITHOUT CLAIM TO ANY PARTICULAR FONT, STYLE, SIZE, OR COLOR.

OWNER OF U.S. REG. NO. 2,194,077.

CLASS 41—EDUCATION AND ENTERTAINMENT

FOR PROVIDING EDUCATIONAL INSTRUCTION AND CLASSES IN THE FIELDS OF INTERPERSONAL AND INTRAPERSONAL COMMUNICATION, AND PARENTAL TRAINING VIA GLOBAL COMPUTER AND COMMUNICATIONS NETWORKS; PROVIDING LIVE AND ONLINE INSTRUCTION AND CLASSES IN THE FIELDS OF INTERPERSONAL AND INTRAPERSONAL COMMUNICATION, AND PARENTAL TRAINING, AND DISTRIBUTION OF EDUCATIONAL MATERIALS IN CONNECTION THEREWITH (U.S. CLS. 100, 101 AND 107).

FIRST USE 3-10-1998; IN COMMERCE 3-10-1998.

CLASS 45—PERSONAL AND LEGAL SERVICES

FOR PROVIDING CONSULTING SERVICES IN THE FIELD OF PARENTING CONCERNING INTRAFAMILY RELATIONSHIPS AND THE FIELD OF PERSONAL GROWTH; PROVIDING A WEB SITE FEATURING INFORMATION AND CONTENT IN THE FIELD OF PARENTING CONCERNING INTRAFAMILY RELATIONSHIPS AND THE FIELD OF PERSONAL GROWTH (U.S. CLS. 100 AND 101).

FIRST USE 3-10-1998; IN COMMERCE 3-10-1998.
ALYSSA STEEL, EXAMINING ATTORNEY

SN 85-384,845. BLACKARD, SANDRA RUTH, DBA LANGUAGE OF LISTENING, ROUND ROCK, TX. FILED 7-29-2011.

SAY WHAT YOU SEE

THE MARK CONSISTS OF STANDARD CHARACTERS WITHOUT CLAIM TO ANY PARTICULAR FONT, STYLE, SIZE, OR COLOR.

OWNER OF U.S. REG. NO. 3,273,822.

CLASS 9—ELECTRICAL AND SCIENTIFIC APPARATUS

FOR PRE-RECORDED ELECTRONIC AND DIGITAL MEDIA FEATURING INSTRUCTION IN THE FIELDS OF INTERPERSONAL COMMUNICATION, PARENTING SKILLS, AND PERSONAL GROWTH (U.S. CLS. 21, 23, 26, 36 AND 38).

FIRST USE 1-10-2004; IN COMMERCE 5-22-2005.

CLASS 41—EDUCATION AND ENTERTAINMENT

FOR PROVIDING EDUCATIONAL INSTRUCTION AND CLASSES IN THE FIELDS OF INTERPERSONAL AND INTRAPERSONAL COMMUNICATION, AND PARENTAL TRAINING VIA GLOBAL COMPUTER AND COMMUNICATIONS NETWORKS; PROVIDING LIVE AND ONLINE INSTRUCTION AND CLASSES IN THE FIELDS OF INTERPERSONAL AND INTRAPERSONAL COMMUNICATION, AND PARENTAL TRAINING, AND DISTRIBUTION OF EDUCATIONAL MATERIALS IN CONNECTION THEREWITH (U.S. CLS. 100, 101 AND 107).

FIRST USE 1-10-2004; IN COMMERCE 5-22-2005.
ALYSSA STEEL, EXAMINING ATTORNEY

SN 85-387,064. EXCELLIGENCE LEARNING CORPORATION, DBA DISCOUNT SCHOOL SUPPLY, MONTEREY, CA. FILED 8-2-2011.

Excellerations

THE MARK CONSISTS OF STANDARD CHARACTERS WITHOUT CLAIM TO ANY PARTICULAR FONT, STYLE, SIZE, OR COLOR.

CLASS 15—MUSICAL INSTRUMENTS

FOR EDUCATIONAL PRODUCTS INTENDED TO DEVELOP YOUNG CHILDREN'S COGNITIVE AND CREATIVE ABILITIES IN THE SUBJECT AREA OF MUSIC, NAMELY, MUSICAL INSTRUMENTS (U.S. CLS. 2, 21 AND 36).

CLASS 16—PAPER GOODS AND PRINTED MATTER

FOR EDUCATIONAL PRODUCTS INTENDED TO DEVELOP YOUNG CHILDREN'S COGNITIVE AND CREATIVE ABILITIES IN THE SUBJECT AREAS OF MATH, LANGUAGE, LITERACY, SCIENCE, SOCIAL STUDIES, MUSIC, DRAMATIC PLAY, AND ARTS AND CRAFTS, NAMELY, FLASH CARDS, CURRICULUM-BASED CHILDREN'S ARTS AND CRAFT KITS, PRINTED WALL CHARTS, PRINTED WALL CHARTS FEATURING POCKETS, AND POSTERS (U.S. CLS. 2, 5, 22, 23, 29, 37, 38 AND 50).

CLASS 25—CLOTHING

FOR EDUCATIONAL PRODUCTS INTENDED TO DEVELOP YOUNG CHILDREN'S COGNITIVE AND CREATIVE ABILITIES IN THE SUBJECT AREAS OF MATH, LANGUAGE, LITERACY, SCIENCE, SOCIAL STUDIES, MUSIC, DRAMATIC PLAY, AND ARTS AND CRAFTS, NAMELY, WEARABLE ACTIVITY VESTS AND APRONS (U.S. CLS. 22 AND 39).

CLASS 28—TOYS AND SPORTING GOODS

FOR EDUCATIONAL PRODUCTS AND TOYS INTENDED TO DEVELOP YOUNG CHILDREN'S COGNITIVE AND CREATIVE ABILITIES IN THE SUBJECT AREAS OF MATH, LANGUAGE, LITERACY, SCIENCE, SOCIAL STUDIES, MUSIC, DRAMATIC PLAY, AND ARTS AND CRAFTS, NAMELY, CARD GAMES, PUZZLES, FLOOR PUZZLES, BOARD GAMES, TABLE TOP MULTIPLE ACTIVITY SETS, TOY SCIENCE KITS, PLUSH TOYS, DOLLS, PUPPETS, TABLE TOP AND STANDING PUPPET THEATERS, PLASTIC AND WOOD FIGURES, ROLE PLAYING TOOLS AND PLAY SETS; EDUCATIONAL PRODUCTS AND EQUIPMENT INTENDED TO DEVELOP YOUNG CHILDREN'S FINE AND GROSS MOTOR SKILLS, NAMELY, BLOCKS AND CONSTRUCTION TOYS, TOY VEHICLES, LACING TOOLS, PLASTIC MANIPULATIVES, TABLE TOP MULTIPLE ACTIVITY SETS, TOYS AND SEWN ARTICLES THAT TEACH BUTTONING, LACING AND OTHER DRESSING SKILLS, EQUIPMENT FOR DEVELOPING BALANCE AND COORDINATION, NAMELY, BALANCE BEAMS, OBSTACLE COURSE SETS, PLASTIC HOOPS, AND STEPPING STONES, PLAY TENTS, PLAY TUNNELS, PLAY YARDS, STREAMERS, PLAY PARACHUTES, PLAY SCARVES, BEAN BAGS, PLAY BALLS, AIMING AND TOSsing TOYS, TOY SAND AND WATER TABLES, SAND AND WATER PLAY TOYS, NAMELY, BUCKETS, FUNNELS, SAND MOLDS, SCOOPS, SHOVELS, AND FLOATING TOYS (U.S. CLS. 22, 23, 38 AND 50).

PATRICIA EVANKO, EXAMINING ATTORNEY

SN 85-387,171. NATIONAL WOMEN'S LAW CENTER, WASHINGTON, DC. FILED 8-2-2011.

**DON'T DISCOUNT WOMEN
SOCIAL SECURITY IS WOMEN'S
SECURITY.**

THE MARK CONSISTS OF STANDARD CHARACTERS WITHOUT CLAIM TO ANY PARTICULAR FONT, STYLE, SIZE, OR COLOR.

CLASS 9—ELECTRICAL AND SCIENTIFIC APPARATUS

FOR DOWNLOADABLE EDUCATIONAL WEBINARS FEATURING INSTRUCTION IN THE FIELD OF LAWS, POLICIES, AND PROPOSED LEGISLATION AND POLICIES REGARDING ECONOMIC OPPORTUNITY AND FAIRNESS FOR WOMEN, GIRLS AND FAMILIES; DOWNLOADABLE FACT SHEETS FEATURING INFORMATION ABOUT LAWS, POLICIES, AND PROPOSED LEGISLATION AND POLICIES REGARDING ECONOMIC OPPORTUNITY AND FAIRNESS FOR WOMEN, GIRLS AND FAMILIES (U.S. CLS. 21, 23, 26, 36 AND 38).

CLASS 35—ADVERTISING AND BUSINESS

FOR PROMOTING PUBLIC AWARENESS OF LAWS, POLICIES, AND PROPOSED LEGISLATION AND POLICIES REGARDING ECONOMIC OPPORTUNITY AND FAIRNESS FOR WOMEN, GIRLS AND FAMILIES (U.S. CLS. 100, 101 AND 102).

CLASS 45—PERSONAL AND LEGAL SERVICES

FOR PROVIDING A WEBSITE FEATURING INFORMATION IN THE FIELD OF LAWS, LEGAL POLICIES, AND PROPOSED LEGISLATION AND LEGAL POLICIES REGARDING ECONOMIC OPPORTUNITY AND FAIRNESS FOR WOMEN, GIRLS AND FAMILIES; PROVIDING INFORMATION AND NEWS IN THE FIELD OF LAWS, LEGAL POLICIES, PROPOSED LEGISLATION AND PROPOSED LEGAL POLICIES REGARDING ECONOMIC OPPORTUNITY AND FAIRNESS FOR WOMEN, GIRLS AND FAMILIES VIA ELECTRONIC MAIL (U.S. CLS. 100 AND 101).

JOHN E. MICHOS, EXAMINING ATTORNEY

SN 85-387,218. NATIONAL WOMEN'S LAW CENTER, WASHINGTON, DC. FILED 8-2-2011.

**DON'T DISCOUNT WOMEN
DEMAND FAIR CHANGE NOT
SPARE CHANGE.**

THE MARK CONSISTS OF STANDARD CHARACTERS WITHOUT CLAIM TO ANY PARTICULAR FONT, STYLE, SIZE, OR COLOR.

CLASS 9—ELECTRICAL AND SCIENTIFIC APPARATUS

FOR DOWNLOADABLE EDUCATIONAL WEBINARS FEATURING INSTRUCTION IN THE FIELD OF LAWS, POLICIES, AND PROPOSED LEGISLATION AND POLICIES REGARDING ECONOMIC OPPORTUNITY AND FAIRNESS FOR WOMEN, GIRLS AND FAMILIES; DOWNLOADABLE FACT SHEETS FEATURING INFORMATION ABOUT LAWS, POLICIES, AND PROPOSED LEGISLATION AND POLICIES REGARDING ECONOMIC OPPORTUNITY AND FAIRNESS FOR WOMEN, GIRLS AND FAMILIES (U.S. CLS. 21, 23, 26, 36 AND 38).

CLASS 35—ADVERTISING AND BUSINESS

FOR PROMOTING PUBLIC AWARENESS OF LAWS, POLICIES, AND PROPOSED LEGISLATION AND POLICIES REGARDING ECONOMIC OPPORTUNITY AND FAIRNESS FOR WOMEN, GIRLS AND FAMILIES (U.S. CLS. 100, 101 AND 102).

CLASS 45—PERSONAL AND LEGAL SERVICES

FOR PROVIDING A WEBSITE FEATURING INFORMATION IN THE FIELD OF LAWS, LEGAL POLICIES, AND PROPOSED LEGISLATION AND LEGAL POLICIES REGARDING ECONOMIC OPPORTUNITY AND FAIRNESS FOR WOMEN, GIRLS AND FAMILIES; PROVIDING INFORMATION AND NEWS IN THE FIELD OF LAWS, LEGAL POLICIES, PROPOSED LEGISLATION AND PROPOSED LEGAL POLICIES REGARDING ECONOMIC OPPORTUNITY AND FAIRNESS FOR WOMEN, GIRLS AND FAMILIES VIA ELECTRONIC MAIL (U.S. CLS. 100 AND 101).

JOHN E. MICHOS, EXAMINING ATTORNEY

SN 85-388,942. ABSOLUTELY GOLF & TRAVEL, LLC, DARIEN, CT. FILED 8-3-2011.

ABSOLUTELY GOLF

THE MARK CONSISTS OF STANDARD CHARACTERS WITHOUT CLAIM TO ANY PARTICULAR FONT, STYLE, SIZE, OR COLOR.

NO CLAIM IS MADE TO THE EXCLUSIVE RIGHT TO USE "GOLF", APART FROM THE MARK AS SHOWN.

CLASS 39—TRANSPORTATION AND STORAGE

FOR ARRANGING AND COORDINATING TRAVEL ARRANGEMENTS FOR INDIVIDUALS AND GROUPS, NAMELY, FOR GOLFING OUTINGS; MAKING RESERVATIONS FOR TRANSPORTATION, ORGANIZING, AND ARRANGING TRAVEL ACTIVITIES, NAMELY, TOURS, TRAVEL TO EVENTS AND TRAVEL TO ATTRACTIONS; ORGANIZATION OF TRAVEL; PROVIDING A WEBSITE FEATURING TRAVEL INFORMATION AND PROVIDING LINKS TO WEBSITES OF OTHERS FEATURING TRAVEL INFORMATION; PROVIDING INFORMATION VIA A WEBSITE IN THE FIELD OF TRAVEL; TRAVEL AGENCY SERVICES, NAMELY, MAKING RESERVATIONS AND BOOKINGS FOR TRANSPORTATION; TRAVEL AND TOUR INFORMATION SERVICE; TRAVEL AND TOUR TICKET RESERVATION SERVICE; TRAVEL BOOKING AGENCIES; TRAVEL GUIDE AND TRAVEL INFORMATION SERVICES (U.S. CLS. 100 AND 105).

FIRST USE 5-9-2001; IN COMMERCE 7-12-2001.

CLASS 43—HOTEL AND RESTAURANT SERVICES

FOR PROVIDING INFORMATION CONCERNING HOTEL ACCOMMODATIONS FOR USE BY TRAVELERS; PROVIDING TRAVEL LODGING INFORMATION SERVICES FOR TEMPORARY LODGINGS, AND TRAVEL LODGING BOOKING AGENCY SERVICES FOR TEMPORARY LODGING FOR TRAVELERS; TRAVEL AGENCY SERVICES, NAMELY, MAKING RESERVATIONS AND BOOKING FOR TEMPORARY LODGING; TRAVEL LODGING AND ACCOMMODATION INFORMATION SERVICES, NAMELY, PROVIDING TRAVEL ACCOMMODATION INFORMATION FOR TEMPORARY LODGINGS FOR USE IN PLANNING AND REPORTING ON CORPORATE TRAVEL (U.S. CLS. 100 AND 101).

FIRST USE 5-9-2001; IN COMMERCE 7-12-2001.
CAROLINE WOOD, EXAMINING ATTORNEY

SN 85-390,872. FOCUSRITE AUDIO ENGINEERING LIMITED, WYCOMBE, BUCKINGHAMSHIRE, UNITED KINGDOM, FILED 8-5-2011.

VRM

THE MARK CONSISTS OF STANDARD CHARACTERS WITHOUT CLAIM TO ANY PARTICULAR FONT, STYLE, SIZE, OR COLOR.

PRIORITY CLAIMED UNDER SEC. 44(D) ON ERPN CMNTY TM OFC APPLICATION NO. 009721291, FILED 2-8-2011, REG. NO. 009721291, DATED 6-17-2011, EXPIRES 2-8-2021.

CLASS 9—ELECTRICAL AND SCIENTIFIC APPARATUS

FOR APPARATUS AND INSTRUMENTS FOR RECORDING, TRANSMISSION, OR REPRODUCTION OF SOUND OR IMAGES; APPARATUS AND INSTRUMENTS FOR AMPLIFICATION OF SOUND, NAMELY, AMPLIFIERS; AUDIO ELECTRICAL AND ELECTRONIC APPARATUS AND INSTRUMENTS, NAMELY, AMPLIFIERS, AUDIO RECEIVERS, DIGITAL SIGNAL PROCESSORS, ANALOGUE SIGNAL PROCESSORS; SOUND RECORDING APPARATUS, NAMELY, SOUND-RECORDING CONSOLES; SOUND PROCESSING APPARATUS, NAMELY, ELECTRONIC SOUND PROCESSING APPARATUS, AMPLIFIERS, AUDIO RECEIVERS, DIGITAL SIGNAL PROCESSORS, ANALOGUE SIGNAL PROCESSORS; LOUDSPEAKERS; SOUND EQUALIZERS; MIDI CONTROLLERS; STRUCTURAL PARTS AND STRUCTURAL FITTINGS FOR ALL THE AFORESAID GOODS (U.S. CLS. 21, 23, 26, 36 AND 38).

CLASS 15—MUSICAL INSTRUMENTS

FOR MUSICAL INSTRUMENTS; ELECTRONIC MUSICAL KEYBOARDS (U.S. CLS. 2, 21 AND 36).
SETH A. RAPPAPORT, EXAMINING ATTORNEY

SN 85-391,750. WRIGHT, MICHAEL S., DBA WRIGHT, MICHAEL S., MONTCLAIR, NJ. FILED 8-8-2011.

Space in Conflict

THE MARK CONSISTS OF STANDARD CHARACTERS WITHOUT CLAIM TO ANY PARTICULAR FONT, STYLE, SIZE, OR COLOR.

NO CLAIM IS MADE TO THE EXCLUSIVE RIGHT TO USE "CONFLICT", APART FROM THE MARK AS SHOWN.

CLASS 41—EDUCATION AND ENTERTAINMENT

FOR CONFLICT RESOLUTION SERVICES, NAMELY, PROVIDING PROFESSIONAL AND PERSONAL COACHING SERVICES, CLASSES, TRAININGS, WORKSHOPS, AND CONFERENCES FOR INDIVIDUALS, GROUPS OF INDIVIDUALS, ORGANIZATIONS AND ENTERPRISES IN THE FIELD OF CONFLICT RESOLUTION AND DISTRIBUTION OF COURSE MATERIALS IN CONNECTION THEREWITH (U.S. CLS. 100, 101 AND 107).

FIRST USE 7-28-2011; IN COMMERCE 7-28-2011.

CLASS 45—PERSONAL AND LEGAL SERVICES

FOR CONFLICT RESOLUTION SERVICES IN THE NATURE OF LEGAL SERVICES, NAMELY, PROVIDING CUSTOMIZED DOCUMENTATION, INFORMATION, COUNSELING, ADVICE AND CONSULTATION SERVICES IN ALL AREAS OF CONFLICT RESOLUTION, AND PROVIDING ALTERNATIVE DISPUTE RESOLUTION SERVICES SUCH AS MEDIATION, NEGOTIATION, AND FACILITATION TO MANAGE AND RESOLVE CONFLICTS (U.S. CLS. 100 AND 101).

FIRST USE 7-28-2011; IN COMMERCE 7-28-2011.
EMILY CHUO, EXAMINING ATTORNEY

SN 85-391,794. THE SMITH ADVISORY GROUP, LLC, WESTFIELD, IN. FILED 8-8-2011.

Investing Sense

THE MARK CONSISTS OF STANDARD CHARACTERS WITHOUT CLAIM TO ANY PARTICULAR FONT, STYLE, SIZE, OR COLOR.

NO CLAIM IS MADE TO THE EXCLUSIVE RIGHT TO USE "INVESTING", APART FROM THE MARK AS SHOWN.

CLASS 16—PAPER GOODS AND PRINTED MATTER

FOR PUBLICATIONS, NAMELY, BROCHURES, BOOKLETS, AND TEACHING MATERIALS IN THE FIELD OF FINANCIAL PLANNING AND INVESTING (U.S. CLS. 2, 5, 22, 23, 29, 37, 38 AND 50).

CLASS 36—INSURANCE AND FINANCIAL

FOR FINANCIAL PLANNING AND INVESTMENT ADVISORY SERVICES (U.S. CLS. 100, 101 AND 102).
MARC LEIPZIG, EXAMINING ATTORNEY

SN 85-393,308. API CULTURE HAUTES LAURENTIDES INC., FERME-NEUVE QC, CANADA, FILED 8-9-2011.

SN 85-396,525. ROADNET TECHNOLOGIES, INC., BALTIMORE, RI. FILED 8-12-2011.



NO CLAIM IS MADE TO THE EXCLUSIVE RIGHT TO USE "MIELS", APART FROM THE MARK AS SHOWN. THE MARK CONSISTS OF DESIGN OF THE TOP OF A MOUNTAIN AND WORDS "MIELS D'ANICET". THE ENGLISH TRANSLATION OF "MIELS D'" IN THE MARK IS "HONEY OF".

CLASS 3—COSMETICS AND CLEANING PREPARATIONS

FOR SOAP, LIP BALMS, BODY CREAM, BUBBLE BATH, SHAMPOOS (U.S. CLS. 1, 4, 6, 50, 51 AND 52).

CLASS 30—STAPLE FOODS

FOR HONEY, ROYAL JELLY FOR FOOD PURPOSES, PROPOLIS FOR FOOD PURPOSES, BEESWAX, SPICE BREAD, COOKIES, HONEY MUSTARD, VINAIGRETTE, NOUGAT, CHOCOLATE, CANDIES, SPREAD CONTAINING HONEY AND NUTS, CAKES (U.S. CL. 46).
CHERYL CLAYTON, EXAMINING ATTORNEY

SN 85-395,160. WINE TABLE, LLC, MOUND, MN. FILED 8-11-2011.



NO CLAIM IS MADE TO THE EXCLUSIVE RIGHT TO USE ".COM", APART FROM THE MARK AS SHOWN.

THE MARK CONSISTS OF TWO RECTANGULAR BOXES ON THE LEFT WITH ONE OVERLAPPING THE OTHER WITH A "W" IN THE CENTER OF THE TWO RECTANGLES AS WELL AS A "T" IN THE FORM OF A CORK SCREW JUST BELOW THE "W". TO THE RIGHT OF THE TWO RECTANGULAR BOXES ARE THE WORDS "WINETABLE.COM YOUR SEAT IS WAITING."

CLASS 43—HOTEL AND RESTAURANT SERVICES

FOR PROVIDING A WEBSITE WHERE GENERAL USERS AND SOMMELIERS CAN POST RATINGS, REVIEWS AND RECOMMENDATIONS ON WINES FOR WINE APPRECIATION PURPOSES (U.S. CLS. 100 AND 101).

CLASS 45—PERSONAL AND LEGAL SERVICES

FOR ONLINE SOCIAL NETWORKING SERVICES (U.S. CLS. 100 AND 101).
WILLIAM BRECKENFELD, EXAMINING ATTORNEY

HOW TO DELIVER

THE MARK CONSISTS OF STANDARD CHARACTERS WITHOUT CLAIM TO ANY PARTICULAR FONT, STYLE, SIZE, OR COLOR.

CLASS 9—ELECTRICAL AND SCIENTIFIC APPARATUS

FOR COMPUTER HARDWARE AND SOFTWARE, AND COMPUTER PERIPHERALS FOR LOADING, PROSPECTIVE AND REAL TIME ROUTING, SCHEDULING, DISPATCHING AND TRACKING OF MOBILE ASSETS, AND PLANNING, ANALYZING, OPTIMIZING AND REPORTING OF LOADING, PROSPECTIVE AND REAL TIME ROUTING, SCHEDULING, DISPATCHING AND TRACKING OF MOBILE ASSETS; COMPUTER HARDWARE AND SOFTWARE, AND COMPUTER PERIPHERALS FOR GPS-BASED ONBOARD MONITORING AND DIAGNOSTICS OF VEHICLES AND VEHICLE OPERATORS, AND MAPPING, TRACKING AND REPORTING OF VEHICLE OPERATING AND USAGE PARAMETERS (U.S. CLS. 21, 23, 26, 36 AND 38).
FIRST USE 5-16-2011; IN COMMERCE 5-16-2011.

CLASS 35—ADVERTISING AND BUSINESS

FOR BUSINESS CONSULTANCY SERVICES IN THE FIELD OF PROSPECTIVE AND REAL TIME ROUTING, SCHEDULING, DISPATCHING AND TRACKING OF MOBILE ASSETS; LOGISTICS MANAGEMENT OF MOBILE ASSETS, NAMELY, PLANNING, ANALYZING, OPTIMIZING, AND REPORTING OF LOADING, PROSPECTIVE AND REALTIME ROUTING, SCHEDULING, DISPATCHING, AND TRACKING OF MOBILE ASSETS FOR OTHERS; TELEMATICS SERVICES, NAMELY, GPS-BASED ONBOARD MONITORING OF VEHICLES AND VEHICLE OPERATORS FOR BUSINESS PURPOSES; TRACKING AND REPORTING OF VEHICLE OPERATING AND USAGE PARAMETERS FOR OTHERS FOR BUSINESS PURPOSES (U.S. CLS. 100, 101 AND 102).
FIRST USE 5-16-2011; IN COMMERCE 5-16-2011.

CLASS 42—SCIENTIFIC AND COMPUTER SERVICES

FOR SOFTWARE AS A SERVICE (SAAS) SERVICES FEATURING SOFTWARE FOR PROSPECTIVE AND REAL TIME ROUTING, SCHEDULING, DISPATCHING AND TRACKING OF MOBILE ASSETS, AND PLANNING, ANALYZING, OPTIMIZING AND REPORTING OF PROSPECTIVE AND REAL TIME ROUTING, SCHEDULING, DISPATCHING AND TRACKING OF MOBILE ASSETS; SOFTWARE AS A SERVICE (SAAS) SERVICES FEATURING SOFTWARE FOR GPS-BASED ONBOARD MONITORING AND DIAGNOSTICS OF VEHICLES AND VEHICLE OPERATORS, AND MAPPING, TRACKING AND REPORTING OF VEHICLE OPERATING AND USAGE PARAMETERS; MAPPING OF VEHICLE OPERATING AND USAGE PARAMETERS FOR OTHERS (U.S. CLS. 100 AND 101).
FIRST USE 5-16-2011; IN COMMERCE 5-16-2011.
MICHELLE DUBOIS, EXAMINING ATTORNEY

SN 85-396,630. ROADNET TECHNOLOGIES, INC., BALTIMORE, MD. FILED 8-12-2011.

CLASS 42—SCIENTIFIC AND COMPUTER SERVICES

FOR SOFTWARE AS A SERVICE (SAAS) SERVICES FEATURING SOFTWARE FOR PROSPECTIVE AND REAL TIME ROUTING, SCHEDULING, DISPATCHING AND TRACKING OF MOBILE ASSETS, AND PLANNING, ANALYZING, OPTIMIZING AND REPORTING OF PROSPECTIVE AND REAL TIME ROUTING, SCHEDULING, DISPATCHING AND TRACKING OF MOBILE ASSETS; SOFTWARE AS A SERVICE (SAAS) SERVICES FEATURING SOFTWARE FOR GPS-BASED ONBOARD MONITORING AND DIAGNOSTICS OF VEHICLES AND VEHICLE OPERATORS, AND MAPPING, TRACKING AND REPORTING OF VEHICLE OPERATING AND USAGE PARAMETERS; MAPPING OF VEHICLE OPERATING AND USAGE PARAMETERS FOR OTHERS (U.S. CLS. 100 AND 101).

FIRST USE 5-16-2011; IN COMMERCE 5-16-2011.
MICHELLE DUBOIS, EXAMINING ATTORNEY

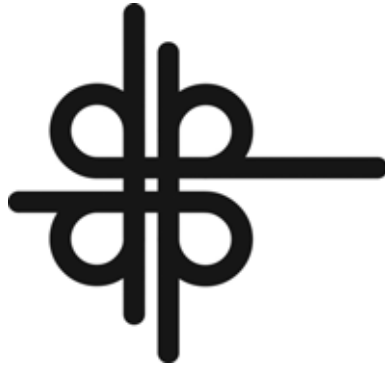

SN 85-396,699. ROADNET TECHNOLOGIES, INC., BALTIMORE, MD. FILED 8-12-2011.

ROADNET TECHNOLOGIES

THE MARK CONSISTS OF LINES LOOPED INTO A CLOVERLEAF DESIGN WITH A LINE EXTENDING TO THE RIGHT AND A LINE EXTENDING TO THE LEFT AND TWO LINES EXTENDING TO THE TOP AND BOTTOM WHICH TOGETHER RESEMBLE A HIGHWAY INTERCHANGE.

THE MARK CONSISTS OF STANDARD CHARACTERS WITHOUT CLAIM TO ANY PARTICULAR FONT, STYLE, SIZE, OR COLOR.

OWNER OF U.S. REG. NOS. 3,346,214, 3,442,891 AND OTHERS.

NO CLAIM IS MADE TO THE EXCLUSIVE RIGHT TO USE "TECHNOLOGIES", APART FROM THE MARK AS SHOWN.

CLASS 9—ELECTRICAL AND SCIENTIFIC APPARATUS

FOR COMPUTER HARDWARE AND SOFTWARE, AND COMPUTER PERIPHERALS FOR LOADING, PROSPECTIVE AND REAL TIME ROUTING, SCHEDULING, DISPATCHING AND TRACKING OF MOBILE ASSETS, AND PLANNING, ANALYZING, OPTIMIZING AND REPORTING OF LOADING, PROSPECTIVE AND REAL TIME ROUTING, SCHEDULING, DISPATCHING AND TRACKING OF MOBILE ASSETS; COMPUTER HARDWARE AND SOFTWARE, AND COMPUTER PERIPHERALS FOR GPS-BASED ONBOARD MONITORING AND DIAGNOSTICS OF VEHICLES AND VEHICLE OPERATORS, AND MAPPING, TRACKING AND REPORTING OF VEHICLE OPERATING AND USAGE PARAMETERS (U.S. CLS. 21, 23, 26, 36 AND 38).

FIRST USE 5-16-2011; IN COMMERCE 5-16-2011.

CLASS 9—ELECTRICAL AND SCIENTIFIC APPARATUS

FOR COMPUTER HARDWARE AND SOFTWARE, AND COMPUTER PERIPHERALS FOR LOADING, PROSPECTIVE AND REAL TIME ROUTING, SCHEDULING, DISPATCHING AND TRACKING OF MOBILE ASSETS, AND PLANNING, ANALYZING, OPTIMIZING AND REPORTING OF LOADING, PROSPECTIVE AND REAL TIME ROUTING, SCHEDULING, DISPATCHING AND TRACKING OF MOBILE ASSETS; COMPUTER HARDWARE AND SOFTWARE, AND COMPUTER PERIPHERALS FOR GPS-BASED ONBOARD MONITORING AND DIAGNOSTICS OF VEHICLES AND VEHICLE OPERATORS, AND MAPPING, TRACKING AND REPORTING OF VEHICLE OPERATING AND USAGE PARAMETERS (U.S. CLS. 21, 23, 26, 36 AND 38).

FIRST USE 5-16-2011; IN COMMERCE 5-16-2011.

CLASS 35—ADVERTISING AND BUSINESS

FOR BUSINESS CONSULTANCY SERVICES IN THE FIELD OF PROSPECTIVE AND REAL TIME ROUTING, SCHEDULING, DISPATCHING AND TRACKING OF MOBILE ASSETS; LOGISTICS MANAGEMENT OF MOBILE ASSETS, NAMELY, PLANNING, ANALYZING, OPTIMIZING, AND REPORTING OF LOADING, PROSPECTIVE AND REALTIME ROUTING, SCHEDULING, DISPATCHING, AND TRACKING OF MOBILE ASSETS FOR OTHERS; TELEMATICS SERVICES, NAMELY, GPS-BASED ONBOARD MONITORING OF VEHICLES AND VEHICLE OPERATORS FOR BUSINESS PURPOSES; TRACKING AND REPORTING OF VEHICLE OPERATING AND USAGE PARAMETERS FOR OTHERS FOR BUSINESS PURPOSES (U.S. CLS. 100, 101 AND 102).

FIRST USE 5-16-2011; IN COMMERCE 5-16-2011.

CLASS 35—ADVERTISING AND BUSINESS

FOR BUSINESS CONSULTANCY SERVICES IN THE FIELD OF PROSPECTIVE AND REAL TIME ROUTING, SCHEDULING, DISPATCHING AND TRACKING OF MOBILE ASSETS; LOGISTICS MANAGEMENT OF MOBILE ASSETS, NAMELY, PLANNING, ANALYZING, OPTIMIZING, AND REPORTING OF LOADING, PROSPECTIVE AND REALTIME ROUTING, SCHEDULING, DISPATCHING, AND TRACKING OF MOBILE ASSETS FOR OTHERS; TELEMATICS SERVICES, NAMELY, GPS-BASED ONBOARD MONITORING OF VEHICLES AND VEHICLE OPERATORS FOR BUSINESS PURPOSES; TRACKING AND REPORTING OF VEHICLE OPERATING AND USAGE PARAMETERS FOR OTHERS FOR BUSINESS PURPOSES (U.S. CLS. 100, 101 AND 102).

FIRST USE 5-16-2011; IN COMMERCE 5-16-2011.

CLASS 42—SCIENTIFIC AND COMPUTER SERVICES

FOR SOFTWARE AS A SERVICE (SAAS) SERVICES FEATURING SOFTWARE FOR PROSPECTIVE AND REAL TIME ROUTING, SCHEDULING, DISPATCHING AND TRACKING OF MOBILE ASSETS, AND PLANNING, ANALYZING, OPTIMIZING AND REPORTING OF PROSPECTIVE AND REAL TIME ROUTING, SCHEDULING, DISPATCHING AND TRACKING OF MOBILE ASSETS; SOFTWARE AS A SERVICE (SAAS) SERVICES FEATURING SOFTWARE FOR GPS-BASED ONBOARD MONITORING AND DIAGNOSTICS OF VEHICLES AND VEHICLE OPERATORS, AND MAPPING, TRACKING AND REPORTING OF VEHICLE OPERATING AND USAGE PARAMETERS; MAPPING OF VEHICLE OPERATING AND USAGE PARAMETERS FOR OTHERS (U.S. CLS. 100 AND 101).

FIRST USE 5-16-2011; IN COMMERCE 5-16-2011.
MICHELLE DUBOIS, EXAMINING ATTORNEY

CLASS 42—SCIENTIFIC AND COMPUTER SERVICES

FOR SOFTWARE AS A SERVICE (SAAS) SERVICES FEATURING SOFTWARE FOR PROSPECTIVE AND REAL TIME ROUTING, SCHEDULING, DISPATCHING AND TRACKING OF MOBILE ASSETS, AND PLANNING, ANALYZING, OPTIMIZING AND REPORTING OF PROSPECTIVE AND REAL TIME ROUTING, SCHEDULING, DISPATCHING AND TRACKING OF MOBILE ASSETS; SOFTWARE AS A SERVICE (SAAS) SERVICES FEATURING SOFTWARE FOR GPS-BASED ONBOARD MONITORING AND DIAGNOSTICS OF VEHICLES AND VEHICLE OPERATORS, AND MAPPING, TRACKING AND REPORTING OF VEHICLE OPERATING AND USAGE PARAMETERS; MAPPING OF VEHICLE OPERATING AND USAGE PARAMETERS FOR OTHERS (U.S. CLS. 100 AND 101).

FIRST USE 5-16-2011; IN COMMERCE 5-16-2011.
MICHELLE DUBOIS, EXAMINING ATTORNEY

SN 85-396,792. ROADNET TECHNOLOGIES, INC., BALTIMORE, MD. FILED 8-12-2011.



OWNER OF U.S. REG. NOS. 3,346,214, 3,442,891 AND OTHERS.

NO CLAIM IS MADE TO THE EXCLUSIVE RIGHT TO USE "TECHNOLOGIES", APART FROM THE MARK AS SHOWN.

THE MARK CONSISTS OF LINES LOOPED INTO A CLOVERLEAF DESIGN WITH A LINE EXTENDING TO THE RIGHT AND A LINE EXTENDING TO THE LEFT AND TWO LINES EXTENDING TO THE TOP AND BOTTOM WHICH TOGETHER RESEMBLE A HIGHWAY INTERCHANGE. THE WORDS "ROADNET TECHNOLOGIES" APPEAR TO THE LOWER RIGHT OF THE DESIGN.

CLASS 9—ELECTRICAL AND SCIENTIFIC APPARATUS

FOR COMPUTER HARDWARE AND SOFTWARE, AND COMPUTER PERIPHERALS FOR LOADING, PROSPECTIVE AND REAL TIME ROUTING, SCHEDULING, DISPATCHING AND TRACKING OF MOBILE ASSETS, AND PLANNING, ANALYZING, OPTIMIZING AND REPORTING OF LOADING, PROSPECTIVE AND REAL TIME ROUTING, SCHEDULING, DISPATCHING AND TRACKING OF MOBILE ASSETS; COMPUTER HARDWARE AND SOFTWARE, AND COMPUTER PERIPHERALS FOR GPS-BASED ONBOARD MONITORING AND DIAGNOSTICS OF VEHICLES AND VEHICLE OPERATORS, AND MAPPING, TRACKING AND REPORTING OF VEHICLE OPERATING AND USAGE PARAMETERS (U.S. CLS. 21, 23, 26, 36 AND 38).

FIRST USE 5-16-2011; IN COMMERCE 5-16-2011.

CLASS 35—ADVERTISING AND BUSINESS

FOR BUSINESS CONSULTANCY SERVICES IN THE FIELD OF PROSPECTIVE AND REAL TIME ROUTING, SCHEDULING, DISPATCHING AND TRACKING OF MOBILE ASSETS; LOGISTICS MANAGEMENT OF MOBILE ASSETS, NAMELY, PLANNING, ANALYZING, OPTIMIZING, AND REPORTING OF LOADING, PROSPECTIVE AND REAL TIME ROUTING, SCHEDULING, DISPATCHING, AND TRACKING OF MOBILE ASSETS FOR OTHERS; TELEMATICS SERVICES, NAMELY, GPS-BASED ONBOARD MONITORING OF VEHICLES AND VEHICLE OPERATORS FOR BUSINESS PURPOSES; TRACKING AND REPORTING OF VEHICLE OPERATING AND USAGE PARAMETERS FOR OTHERS FOR BUSINESS PURPOSES (U.S. CLS. 100, 101 AND 102).

FIRST USE 5-16-2011; IN COMMERCE 5-16-2011.

SN 85-396,982. ROADNET TECHNOLOGIES, INC., BALTIMORE, MD. FILED 8-12-2011.



OWNER OF U.S. REG. NOS. 3,346,214, 3,442,891 AND OTHERS.

NO CLAIM IS MADE TO THE EXCLUSIVE RIGHT TO USE "TECHNOLOGIES", APART FROM THE MARK AS SHOWN.

THE MARK CONSISTS OF LINES LOOPED INTO A CLOVERLEAF DESIGN WITH A LINE EXTENDING TO THE RIGHT AND A LINE EXTENDING TO THE LEFT AND TWO LINES EXTENDING TO THE TOP AND BOTTOM WHICH TOGETHER RESEMBLE A HIGHWAY INTERCHANGE. THE WORDS "ROADNET TECHNOLOGIES" AND "HOW TO DELIVER" APPEAR TO THE LOWER RIGHT OF THE DESIGN.

CLASS 9—ELECTRICAL AND SCIENTIFIC APPARATUS

FOR COMPUTER HARDWARE AND SOFTWARE, AND COMPUTER PERIPHERALS FOR LOADING, PROSPECTIVE AND REAL TIME ROUTING, SCHEDULING, DISPATCHING AND TRACKING OF MOBILE ASSETS, AND PLANNING, ANALYZING, OPTIMIZING AND REPORTING OF LOADING, PROSPECTIVE AND REAL TIME ROUTING, SCHEDULING, DISPATCHING AND TRACKING OF MOBILE ASSETS; COMPUTER HARDWARE AND SOFTWARE, AND COMPUTER PERIPHERALS FOR GPS-BASED ONBOARD MONITORING AND DIAGNOSTICS OF VEHICLES AND VEHICLE OPERATORS, AND MAPPING, TRACKING AND REPORTING OF VEHICLE OPERATING AND USAGE PARAMETERS (U.S. CLS. 21, 23, 26, 36 AND 38).

FIRST USE 5-16-2011; IN COMMERCE 5-16-2011.

CLASS 35—ADVERTISING AND BUSINESS

FOR BUSINESS CONSULTANCY SERVICES IN THE FIELD OF PROSPECTIVE AND REAL TIME ROUTING, SCHEDULING, DISPATCHING AND TRACKING OF MOBILE ASSETS; LOGISTICS MANAGEMENT OF MOBILE ASSETS, NAMELY, PLANNING, ANALYZING, OPTIMIZING, AND REPORTING OF LOADING, PROSPECTIVE AND REALTIME ROUTING, SCHEDULING, DISPATCHING, AND TRACKING OF MOBILE ASSETS FOR OTHERS; TELEMATICS SERVICES, NAMELY, GPS-BASED ONBOARD MONITORING OF VEHICLES AND VEHICLE OPERATORS FOR BUSINESS PURPOSES; TRACKING AND REPORTING OF VEHICLE OPERATING AND USAGE PARAMETERS FOR OTHERS FOR BUSINESS PURPOSES (U.S. CLS. 100, 101 AND 102).
FIRST USE 5-16-2011; IN COMMERCE 5-16-2011.

CLASS 42—SCIENTIFIC AND COMPUTER SERVICES

FOR SOFTWARE AS A SERVICE (SAAS) SERVICES FEATURING SOFTWARE FOR PROSPECTIVE AND REAL TIME ROUTING, SCHEDULING, DISPATCHING AND TRACKING OF MOBILE ASSETS, AND PLANNING, ANALYZING, OPTIMIZING AND REPORTING OF PROSPECTIVE AND REAL TIME ROUTING, SCHEDULING, DISPATCHING AND TRACKING OF MOBILE ASSETS; SOFTWARE AS A SERVICE (SAAS) SERVICES FEATURING SOFTWARE FOR GPS-BASED ONBOARD MONITORING AND DIAGNOSTICS OF VEHICLES AND VEHICLE OPERATORS, AND MAPPING, TRACKING AND REPORTING OF VEHICLE OPERATING AND USAGE PARAMETERS; MAPPING OF VEHICLE OPERATING AND USAGE PARAMETERS FOR OTHERS (U.S. CLS. 100 AND 101).

FIRST USE 5-16-2011; IN COMMERCE 5-16-2011.
MICHELLE DUBOIS, EXAMINING ATTORNEY

SN 85-397,288. LUITPOLD PHARMACEUTICALS, INC., SHIRLEY, NY. FILED 8-13-2011.

REGENCY DENTAL

THE MARK CONSISTS OF STANDARD CHARACTERS WITHOUT CLAIM TO ANY PARTICULAR FONT, STYLE, SIZE, OR COLOR.

NO CLAIM IS MADE TO THE EXCLUSIVE RIGHT TO USE "DENTAL", APART FROM THE MARK AS SHOWN.

CLASS 5—PHARMACEUTICALS

FOR PHARMACEUTICAL PREPARATIONS FOR THE TREATMENT OF PAIN; MEMBRANES AND OTHER DRESSINGS USED FOR DENTAL, PERIODONTAL AND ORTHOPEDIC APPLICATIONS; GROWTH FACTOR ENHANCED PHARMACEUTICAL PREPARATIONS FOR THE TREATMENT OF PERIODONTAL AND CRANIO-MAXILLOFACIAL (CMIF) BONE AND SOFT TISSUE DEFECTS, NAMELY, BONE AND TISSUE DEFECTS OF THE HEAD, JAW, AND FACE AND RELATED TO WOUND HEALING AND TISSUE REPAIR; NATURAL BONE MATERIAL FOR USE IN PERIODONTAL, MAXILLOFACIAL, DENTAL AND ORAL SURGERY AND PROCEDURES, NAMELY, HYDROXYAPATITE FROM AN ORGANIC BOVINE OR EQUINE BONE; COLLAGEN MEMBRANES FOR GUIDED BONE AND TISSUE REGENERATION FOR DENTAL, PERIODONTAL AND ORTHOPEDIC APPLICATIONS (U.S. CLS. 6, 18, 44, 46, 51 AND 52).

CLASS 10—MEDICAL APPARATUS

FOR ARTIFICIAL HUMAN BONE MATERIAL FOR USE IN PERIODONTAL, NAMELY, HYDROXYAPATITE FROM ANORGANIC BOVINE OR EQUINE BONE; SYNTHETIC COLLAGEN MEMBRANES FOR GUIDED BONE AND TISSUE REGENERATION FOR DENTAL, PERIODONTAL AND ORTHOPEDIC APPLICATIONS (U.S. CLS. 26, 39 AND 44).

STEVEN JACKSON, EXAMINING ATTORNEY

SN 85-397,762. ABE'S GARDEN, INC., NASHVILLE, TN. FILED 8-15-2011.

ABE'S GARDEN

THE MARK CONSISTS OF STANDARD CHARACTERS WITHOUT CLAIM TO ANY PARTICULAR FONT, STYLE, SIZE, OR COLOR.

THE NAME(S), PORTRAIT(S), AND/OR SIGNATURE(S) SHOWN IN THE MARK DOES NOT IDENTIFY A PARTICULAR LIVING INDIVIDUAL.

CLASS 41—EDUCATION AND ENTERTAINMENT

FOR HEALTHCARE TRAINING IN THE FIELD OF ALZHEIMER'S DISEASE AND DEMENTIA (U.S. CLS. 100, 101 AND 107).

FIRST USE 1-0-2008; IN COMMERCE 1-0-2008.

CLASS 42—SCIENTIFIC AND COMPUTER SERVICES

FOR MEDICAL RESEARCH IN THE FIELD OF ALZHEIMER'S DISEASE AND DEMENTIA (U.S. CLS. 100 AND 101).

FIRST USE 1-0-2008; IN COMMERCE 1-0-2008.

CLASS 43—HOTEL AND RESTAURANT SERVICES

FOR PROVIDING INDEPENDENT LIVING RESIDENCES AND LIVING FACILITIES; PROVIDING ASSISTED LIVING FACILITIES (U.S. CLS. 100 AND 101).

FIRST USE 1-0-2008; IN COMMERCE 1-0-2008.

CLASS 44—MEDICAL, BEAUTY AND AGRICULTURAL SERVICES

FOR NURSING CARE AND HEALTHCARE SERVICES (U.S. CLS. 100 AND 101).

FIRST USE 1-0-2008; IN COMMERCE 1-0-2008.

WILLIAM BRECKENFELD, EXAMINING ATTORNEY

SN 85-397,866. KEYENCE CORPORATION, OSAKA, JAPAN. FILED 8-15-2011.



OWNER OF U.S. REG. NOS. 2,623,682 AND 2,820,614.

THE MARK CONSISTS OF THE STYLIZED WORD "KEY-ENCE" WHERE THE LETTER "K" HAS A STYLIZED SHADED TRIANGLE DESIGN.

CLASS 7—MACHINERY

FOR MOTORS, ELECTRIC, OTHER THAN FOR LAND VEHICLES; LASER MARKING MACHINES; LASER BEAM MACHINES FOR ENGRAVING NON-ERASABLE CHARACTERS AND CUTTING; PLASTIC PROCESSING MACHINES, NAMELY, EXTRUDERS, STRAND PELLETIZERS AND SELF-THREADING PELLETIZERS, INJECTION MOLDING MACHINES; PRINTING MACHINES FOR COMMERCIAL OR INDUSTRIAL USE; PRINTING MACHINES FOR USE ON SHEET METAL; INDUSTRIAL INK JET PRINTING MACHINES; THREE DIMENSIONAL PRINTING AND MODEL BUILDING MACHINES; THREE DIMENSIONAL MODELING MACHINES (U.S. CLS. 13, 19, 21, 23, 31, 34 AND 35).

CLASS 11—ENVIRONMENTAL CONTROL APPARATUS

FOR AIR FILTERING APPARATUS NAMELY, AIR FILTERING INSTALLATIONS, AIR FILTERS FOR DOMESTIC OR INDUSTRIAL INSTALLATIONS; AIR CLEANING APPARATUS, NAMELY, AIR CLEANING UNITS CONTAINING AN AIR FILTER, ULTRAVIOLET LIGHTS AND A PHOTOCATALYTIC FILTER; IONIZATION APPARATUS FOR THE TREATMENT OF AIR; LIGHTING APPARATUS, NAMELY, LIGHT FIXTURES; LIGHTING APPARATUS FOR OPTICAL SENSORS, IMAGE PROCESSING SENSORS, MICROSCOPES AND BAR CODE READERS; ULTRAVIOLET RAY LAMPS, NOT FOR MEDICAL PURPOSES (U.S. CLS. 13, 21, 23, 31 AND 34).

ALAIN LAPTER, EXAMINING ATTORNEY

SN 85-398,490, THE MCGRAW-HILL COMPANIES, INC., NEW YORK, NY. FILED 8-15-2011.

MCGRAW-HILL CONSTRUCTION

THE MARK CONSISTS OF STANDARD CHARACTERS WITHOUT CLAIM TO ANY PARTICULAR FONT, STYLE, SIZE, OR COLOR.

OWNER OF U.S. REG. NOS. 1,350,345, 3,324,383 AND OTHERS.

NO CLAIM IS MADE TO THE EXCLUSIVE RIGHT TO USE "CONSTRUCTION", APART FROM THE MARK AS SHOWN.

CLASS 35—ADVERTISING AND BUSINESS

FOR (BASED ON USE IN COMMERCE) ARRANGING AND CONDUCTING BUSINESS CONFERENCES IN THE FIELDS OF DESIGN, ARCHITECTURE, AND ENGINEERING AND THE DESIGN, ARCHITECTURE, AND ENGINEERING INDUSTRIES; PROVIDING MARKET RESEARCH RELATING TO THE CONSTRUCTION AND DESIGN INDUSTRIES (U.S. CLS. 100, 101 AND 102).

FIRST USE 0-0-2002; IN COMMERCE 0-0-2002.

CLASS 37—CONSTRUCTION AND REPAIR

FOR (BASED ON USE IN COMMERCE) PROVIDING ON-LINE NEWS AND INFORMATION ABOUT BUILDING CONSTRUCTION AND THE BUILDING CONSTRUCTION INDUSTRIES; PROVIDING ON-LINE INFORMATION ABOUT BUILDING CONSTRUCTION PROJECTS (U.S. CLS. 100, 103 AND 106).

FIRST USE 0-0-2002; IN COMMERCE 0-0-2002.

CLASS 41—EDUCATION AND ENTERTAINMENT

FOR (BASED ON INTENT TO USE) ARRANGING AND CONDUCTING EDUCATIONAL CONFERENCES IN THE FIELDS OF DESIGN, ARCHITECTURE, AND ENGINEERING AND THE DESIGN, ARCHITECTURE, AND ENGINEERING INDUSTRIES (U.S. CLS. 100, 101 AND 107).

CLASS 42—SCIENTIFIC AND COMPUTER SERVICES

FOR (BASED ON INTENT TO USE) PROVIDING ON-LINE NEWS AND INFORMATION ABOUT INTERIOR AND ARCHITECTURAL DESIGN AND THE DESIGN INDUSTRIES; PROVIDING ON-LINE INFORMATION ABOUT TOOLS AND EQUIPMENT FOR USE IN ARCHITECTURAL DESIGN, ENGINEERING, AND CONSTRUCTION INDUSTRIES (U.S. CLS. 100 AND 101).

SHARON MEIER, EXAMINING ATTORNEY

SN 85-398,770, I-APP SERVICES, LLC, DBA I-APP, RESTON, VA. FILED 8-16-2011.



NO CLAIM IS MADE TO THE EXCLUSIVE RIGHT TO USE "I-APP", APART FROM THE MARK AS SHOWN.

THE COLOR(S) BLACK, WHITE AND RED IS/ARE CLAIMED AS A FEATURE OF THE MARK.

THE MARK CONSISTS OF A BOX COMPRISED OF TWO FREE-FLOATING BLACK DIAMONDS WITH WHITE DIAMONDS IN THE MIDDLE WITH A FREE-FLOATING RED DIAMOND ON TOP WITH A WHITE DIAMOND IN THE MIDDLE TO THE LEFT OF THE WORDS "I-APP" IN BLACK, ALL ON A WHITE BACKGROUND.

CLASS 35—ADVERTISING AND BUSINESS

FOR VALUE-ADDED RESELLER AND RELATED BUSINESS CONSULTING SERVICES, NAMELY, DISTRIBUTORSHIP SERVICES FEATURING BUSINESS INTELLIGENCE APPLICATIONS AND ENTERPRISE RESOURCE PLANNING SOFTWARE (U.S. CLS. 100, 101 AND 102).

FIRST USE 7-5-2004; IN COMMERCE 7-5-2004.

CLASS 42—SCIENTIFIC AND COMPUTER SERVICES

FOR SOFTWARE CONSULTING SERVICES IN THE FIELD OF BUSINESS INTELLIGENCE APPLICATIONS AND ENTERPRISE RESOURCE PLANNING SOFTWARE; COMPUTER PROGRAMMING AND SOFTWARE DESIGN; TECHNICAL SUPPORT SERVICES, NAMELY, REMOTE ADMINISTRATION AND MANAGEMENT OF IN-HOUSE AND HOSTED DATACENTER DEVICES, DATABASES AND SOFTWARE APPLICATIONS (U.S. CLS. 100 AND 101).

FIRST USE 7-5-2004; IN COMMERCE 7-5-2004.
JOHN HWANG, EXAMINING ATTORNEY

SN 85-398,853. LOVEURNS LLC, TRAVERSE CITY, MI.
FILED 8-16-2011.

SN 85-400,471. MILWAUKEE SCHOOL OF ENGINEERING
(MSOE), MILWAUKEE, WI. FILED 8-17-2011.



THE MARK CONSISTS OF A STYLIZED HEART CONTAINED WITHIN A BOX, FOLLOWED BY THE PHRASE "LOVEURNS".

CLASS 14—JEWELRY

FOR JEWELRY AND JEWELRY CASES (U.S. CLS. 2, 27, 28 AND 50).
FIRST USE 6-25-2011; IN COMMERCE 6-25-2011.

CLASS 20—FURNITURE AND ARTICLES NOT OTHERWISE CLASSIFIED

FOR FUNERARY URNS, NAMELY, CREMATION URNS, KEEPSAKE URNS, DECORATIVE URNS, AND MEMORIAL URNS; DECORATIVE WOODEN CASES, DISPLAY CASES AND BAGS FOR STORING THEREFORE; TEA LIGHTS (U.S. CLS. 2, 13, 22, 25, 32 AND 50).
FIRST USE 6-25-2011; IN COMMERCE 6-25-2011.
MICHELE SWAIN, EXAMINING ATTORNEY

SN 85-398,985. AMAZON TECHNOLOGIES, INC., RENO, NV.
FILED 8-16-2011.

BETTERIZER

THE MARK CONSISTS OF STANDARD CHARACTERS WITHOUT CLAIM TO ANY PARTICULAR FONT, STYLE, SIZE, OR COLOR.

CLASS 35—ADVERTISING AND BUSINESS

FOR PROVIDING CONSUMERS PERSONALIZED PRODUCT RECOMMENDATIONS VIA THE INTERNET, NAMELY, COMPARISON INFORMATION FOR A WIDE VARIETY OF PRODUCTS BASED ON PRODUCT CHARACTERISTICS AND PERSONAL PREFERENCES (U.S. CLS. 100, 101 AND 102).

CLASS 42—SCIENTIFIC AND COMPUTER SERVICES

FOR PROVIDING TEMPORARY USE OF AN ON-LINE NON-DOWNLOADABLE SOFTWARE TOOL IN THE FIELD OF CONSUMER PRODUCT INFORMATION FOR USE IN DISPLAYING THE FEATURES OF DIFFERENT PRODUCTS AND SERVICES TO BE EVALUATED BY A SPECIFIC CUSTOMER IN ORDER TO PROVIDE THAT SPECIFIC CUSTOMER WITH MORE PERSONALIZED PRODUCT RECOMMENDATIONS (U.S. CLS. 100 AND 101).
DANIEL CAPSHAW, EXAMINING ATTORNEY

WISCONSIN STEM PATHWAYS

THE MARK CONSISTS OF STANDARD CHARACTERS WITHOUT CLAIM TO ANY PARTICULAR FONT, STYLE, SIZE, OR COLOR.

NO CLAIM IS MADE TO THE EXCLUSIVE RIGHT TO USE "WISCONSIN STEM", APART FROM THE MARK AS SHOWN.

CLASS 9—ELECTRICAL AND SCIENTIFIC APPARATUS

FOR DOWNLOADABLE ELECTRONIC PUBLICATIONS IN THE NATURE OF PERIODICALS, MAGAZINES, PAMPHLETS, AND BROCHURES IN THE FIELDS OF TECHNOLOGY, SCIENCE, MATHEMATICS, ENGINEERING, AND BIOMEDICINE (U.S. CLS. 21, 23, 26, 36 AND 38).

CLASS 16—PAPER GOODS AND PRINTED MATTER

FOR PRINTED EDUCATIONAL RESOURCE MATERIALS, CASE STUDIES, BEST PRACTICES, INTERVIEWS, AND FEATURES IN THE NATURE OF PERIODICALS, MAGAZINES, PAMPHLETS, AND BROCHURES IN THE FIELDS OF TECHNOLOGY, SCIENCE, MATHEMATICS, ENGINEERING, AND BIOMEDICINE; PRINTED EDUCATIONAL RESOURCE MATERIALS TO PROMOTE AWARENESS, PROVIDE ASSISTANCE, AND STRENGTHEN PARTNERSHIPS FOR K-12 EDUCATION AMONG EDUCATORS, PARENTS, AND INDUSTRY REPRESENTATIVES IN THE NATURE OF PERIODICALS, MAGAZINES, PAMPHLETS, AND BROCHURES IN THE FIELDS OF TECHNOLOGY, SCIENCE, MATHEMATICS, ENGINEERING, AND BIOMEDICINE (U.S. CLS. 2, 5, 22, 23, 29, 37, 38 AND 50).

CLASS 41—EDUCATION AND ENTERTAINMENT

FOR PROVIDING ON-LINE PUBLICATIONS IN THE NATURE OF PERIODICALS, MAGAZINES, PAMPHLETS, AND BROCHURES IN THE FIELDS OF TECHNOLOGY, SCIENCE, MATHEMATICS, ENGINEERING, AND BIOMEDICINE (U.S. CLS. 100, 101 AND 107).
DOUGLAS LEE, EXAMINING ATTORNEY

SN 85-400,759. HAPPYCOW, INC., SANTA MONICA, CA.
FILED 8-17-2011.

HappyCow

THE MARK CONSISTS OF STANDARD CHARACTERS WITHOUT CLAIM TO ANY PARTICULAR FONT, STYLE, SIZE, OR COLOR.

CLASS 35—ADVERTISING AND BUSINESS

FOR PROVIDING AN ONLINE SEARCHABLE BUSINESS DIRECTORY FEATURING A VEGETARIAN DINING GUIDE AND DIRECTORY OF NATURAL HEALTH FOOD STORES AND BUSINESSES THAT OFFER HEALTHY, CONSCIENTIOUS CHOICES FOR PEOPLE ON A PLANT-BASED DIET, IN THE NATURE OF NUTRITION AND HEALTH TIPS, VEGAN RECIPES, RAW FOODS, VEGANISM AND OTHER VEGETARIAN ORIENTED TOPICS VIA A GLOBAL COMMUNICATIONS NETWORK; PROVIDING A WEBSITE WHERE USERS CAN POST RATINGS, REVIEWS AND RECOMMENDATIONS ON RESTAURANTS, FOOD MARKETS, GROCERY STORES, SERVICE PROVIDERS, AND OTHER RESOURCES RELATED TO THE VEGETARIAN, VEGAN, AND ENVIRONMENTALLY CONSCIOUS LIFESTYLES; PROVIDING A WEBSITE FEATURING BUSINESS DIRECTORY COMPILATIONS, RANKINGS, RATINGS, REVIEWS, REFERRALS AND RECOMMENDATIONS RELATING TO BUSINESS ORGANIZATIONS, SERVICE PROVIDERS, AND SELLERS AND RE-SELLERS OF PRODUCTS USING A GLOBAL COMPUTER NETWORK AND PROVIDED TO A SOCIAL NETWORK OF PARTICIPATING USERS (U.S. CLS. 100, 101 AND 102).

FIRST USE 11-30-1999; IN COMMERCE 11-30-1999.

CLASS 41—EDUCATION AND ENTERTAINMENT

FOR ELECTRONIC PUBLISHING SERVICES, NAMELY, ONLINE PUBLICATION OF VIDEO, TEXT AND GRAPHIC WORKS IN THE NATURE OF NEWSLETTERS, WEBLOGS, VIDEO WEBLOGS AND ONLINE EDITION NEWSPAPERS IN THE FIELD OF VEGETARIAN, VEGAN, ORGANIC, NATURAL, SUSTAINABLE, ANIMAL RIGHTS, RAW FOODS, AND ENVIRONMENTALLY CONSCIOUS LIFESTYLES; ENTERTAINMENT AND EDUCATIONAL SERVICES, NAMELY, PRESENTATION OF PRE-RECORDED VIDEOS AND DISPLAYING OF EXHIBITS FEATURING TEXT AND GRAPHICS ALL IN THE FIELD OF HEALTHY DIETARY CHOICES, ANIMAL RIGHTS, AND CONSCIENTIOUS LIVING; PROVIDING INFORMATION, NEWS AND EDITORIAL COMMENTARY IN THE FIELD OF CURRENT EVENTS RELATING TO ANIMAL RIGHTS, SUSTAINABLE LIVING, VEGANISM, VEGETARIANISM AND ISSUES RELEVANT TO THOSE ON A PLANT BASED DIET (U.S. CLS. 100, 101 AND 107).

FIRST USE 11-30-1999; IN COMMERCE 11-30-1999.
ALYSSA STEEL, EXAMINING ATTORNEY

SN 85-402,754. GOLDLINE INTERNATIONAL, INC., SANTA MONICA, CA. FILED 8-19-2011.

Goldline 
INTERNATIONAL, INC.

OWNER OF U.S. REG. NOS. 1,039,862, 1,512,052 AND OTHERS.

NO CLAIM IS MADE TO THE EXCLUSIVE RIGHT TO USE "INTERNATIONAL, INC.", APART FROM THE MARK AS SHOWN.

THE COLOR(S) YELLOW, BLACK AND WHITE IS/ARE CLAIMED AS A FEATURE OF THE MARK.

THE MARK CONSISTS OF THREE DIMENSIONAL IMAGE OF THREE CONTIGUOUS STACKS OF RECTANGULAR BLOCKS IN THE COLORS YELLOW AND WHITE: FROM LEFT TO RIGHT, THE FIRST STACK CONSISTS OF FOUR BLOCKS; THE SECOND STACK CONSISTS OF SIX BLOCKS; AND THE THIRD STACK CONSISTS OF EIGHT BLOCKS. THE IMAGE APPEARS THREE DIMENSIONAL BECAUSE THE TOP AND LEFT SIDES CONSIST OF A THICKER YELLOW OUTLINE. THE IMAGE IS NOT SHADED. THE WORDS "GOLDLINE INTERNATIONAL, INC." IN BLACK APPEAR TO THE LEFT OF THE STACKED BLOCKS WITH A BLACK HORIZONTAL LINE BELOW THE WORDING.

CLASS 14—JEWELRY

FOR GOLD AND OTHER PRECIOUS METALS, THEIR ALLOYS, AND INGOTS MADE THEREFROM; GOLD AND SILVER COINS; COLLECTIBLE AND COMMEMORATIVE COINS (U.S. CLS. 2, 27, 28 AND 50).

FIRST USE 6-1-1995; IN COMMERCE 6-1-1995.

CLASS 36—INSURANCE AND FINANCIAL

FOR PROVIDING FINANCIAL INFORMATION IN THE FIELD OF PRICING AND MARKET VALUES OF COINS INCLUDING THOSE COMPRISING PRECIOUS METALS, AND FINANCIAL INFORMATION CONCERNING THE FIELD OF TRADING IN GOLD AND OTHER PRECIOUS METALS; PROVIDING A WEBSITE FEATURING INFORMATION AND NEWS IN THE FIELD OF FINANCES, ECONOMICS AND THE TRADING OF PRECIOUS METALS; FINANCIAL SERVICES, NAMELY, PRECIOUS METAL INVESTMENTS (U.S. CLS. 100, 101 AND 102).

FIRST USE 6-1-1995; IN COMMERCE 6-1-1995.

CLASS 39—TRANSPORTATION AND STORAGE

FOR STORAGE OF PRECIOUS METALS (U.S. CLS. 100 AND 105).

FIRST USE 6-1-1995; IN COMMERCE 6-1-1995.

CLASS 41—EDUCATION AND ENTERTAINMENT

FOR EDUCATIONAL AND ENTERTAINMENT SERVICES, NAMELY, A CONTINUING PROGRAM ABOUT FINANCES, ECONOMICS AND PRECIOUS METALS ACCESSIBLE BY RADIO, SATELLITE, AUDIO AND COMPUTER NETWORKS (U.S. CLS. 100, 101 AND 107).

FIRST USE 6-1-1995; IN COMMERCE 6-1-1995.

LINDA ESTRADA, EXAMINING ATTORNEY

SN 85-403,544. FLYROD COMBAT LLC, BOCA RATON, FL. FILED 8-22-2011.

FlyRod Combat

THE MARK CONSISTS OF STANDARD CHARACTERS WITHOUT CLAIM TO ANY PARTICULAR FONT, STYLE, SIZE, OR COLOR.

NO CLAIM IS MADE TO THE EXCLUSIVE RIGHT TO USE "FLYROD", APART FROM THE MARK AS SHOWN.

CLASS 9—ELECTRICAL AND SCIENTIFIC APPARATUS

FOR DIGITAL MEDIA, NAMELY, PRE-RECORDED CDS, DVDS, DOWNLOADABLE AUDIO FILES FEATURING INFORMATION AND VIDEOS ABOUT FLY FISHING (U.S. CLS. 21, 23, 26, 36 AND 38).

CLASS 16—PAPER GOODS AND PRINTED MATTER

FOR DECALS; STICKERS (U.S. CLS. 2, 5, 22, 23, 29, 37, 38 AND 50).

CLASS 25—CLOTHING

FOR BEANIES; BOOTS; CAPS; HATS; HEAD SCARVES; JACKETS; PANTS; SANDALS; SHIRTS; SHIRTS AND SHORT-SLEEVED SHIRTS; SHOES; SHORT-SLEEVED OR LONG-SLEEVED T-SHIRTS; SHORTS; SOCKS (U.S. CLS. 22 AND 39).

CLASS 35—ADVERTISING AND BUSINESS

FOR ADVERTISING AND MARKETING SERVICES, NAMELY, PROMOTING THE GOODS AND SERVICES OF OTHERS (U.S. CLS. 100, 101 AND 102).

CLASS 41—EDUCATION AND ENTERTAINMENT

FOR ENTERTAINMENT AND EDUCATIONAL SERVICES, NAMELY, THE PRESENTATION OF SEMINARS, LECTURES, WORKSHOPS AND PANEL DISCUSSIONS, AND ONGOING TELEVISION AND RADIO TALK SHOWS ALL IN THE FIELD OF PUBLIC INTEREST CONCERNING FLY FISHING (U.S. CLS. 100, 101 AND 107).

FRANK LATTUCA, EXAMINING ATTORNEY

SN 85-403,617. COTTAGE HOME INC., CAPE NEDDICK, ME. FILED 8-22-2011.

COTTAGE  HOME

THE MARK CONSISTS OF THE WORDS "COTTAGE HOME" WITH AN IMAGE OF THREE LEAVES SET BETWEEN THE TWO WORDS.

SEC. 2(F) AS TO "COTTAGE HOME".

CLASS 11—ENVIRONMENTAL CONTROL APPARATUS

FOR LAMPS; CHANDELIERS; ELECTRIC LIGHTING FIXTURES, NAMELY, SCONCES; AND LANTERNS (U.S. CLS. 13, 21, 23, 31 AND 34).

FIRST USE 10-1-2002; IN COMMERCE 11-1-2002.

CLASS 20—FURNITURE AND ARTICLES NOT OTHERWISE CLASSIFIED

FOR FURNITURE, NAMELY, CUSTOM FURNITURE, PAINTED FURNITURE, FURNITURE MADE FROM RECLAIMED WOOD, FURNITURE WITH FITTED FABRIC SLIPCOVERS, FURNITURE MADE FROM WICKER; BEDROOM FURNITURE, LIVING ROOM FURNITURE, OUTDOOR FURNITURE; AND PATIO FURNITURE; BENCHES; STOOLS; COUCHES; SOFAS; TABLES, NAMELY, TRESTLE TABLES, PEDESTAL TABLES, BEDSIDE TABLES, CONSOLE TABLES, DINING ROOM TABLES, DISPLAY TABLES, DRESSING TABLES, DROP LEAF TABLES, END TABLES, AND OCCASIONAL TABLES; CHAIRS, NAMELY, DINING CHAIRS, LOUNGE CHAIRS, ROCKING CHAIRS, AND RECLINING CHAIRS; ACCENT PILLOWS; WALL PLAQUES MADE OF PLASTIC OR WOOD; MIRRORS; AND PICTURE FRAMES (U.S. CLS. 2, 13, 22, 25, 32 AND 50).

FIRST USE 10-1-2002; IN COMMERCE 11-1-2002.

CLASS 27—FLOOR COVERINGS

FOR AREA RUGS AND CARPETS (U.S. CLS. 19, 20, 37, 42 AND 50).

FIRST USE 10-1-2002; IN COMMERCE 11-1-2002.

CLASS 42—SCIENTIFIC AND COMPUTER SERVICES

FOR INTERIOR DESIGN SERVICES, NAMELY, SPACE PLANNING, FURNITURE SELECTION AND MATERIAL AND SURFACE SELECTION, ROOM DESIGN, INTERIOR DECORATION CONSULTATION, COLOR ANALYSIS FOR PURPOSES OF INTERIOR DESIGN, AND DESIGN OF SPECIALTY INTERIOR AND EXTERIOR ENVIRONMENT SETTINGS (U.S. CLS. 100 AND 101).

FIRST USE 10-1-2002; IN COMMERCE 11-1-2002.

TIMOTHY FINNEGAN, EXAMINING ATTORNEY

SN 85-403,834. HERRELL, STEVE, NORTHAMPTON, MA. AND HERRELL, JUDY, NORTHAMPTON, MA. FILED 8-22-2011.



OWNER OF U.S. REG. NO. 1,373,919.

NO CLAIM IS MADE TO THE EXCLUSIVE RIGHT TO USE THE ICE CREAM SUNDAE DESIGN, APART FROM THE MARK AS SHOWN.

THE COLOR(S) YELLOW, RED, WHITE, BROWN, PINK, BLACK, BLUE, GRAY, SILVER, AND BEIGE IS/ARE CLAIMED AS A FEATURE OF THE MARK.

THE MARK CONSISTS OF THE RIGHT PROFILE OF A SMILING YELLOW AND WHITE POLAR BEAR OUTLINED IN BROWN WITH BLACK CLAWS ON ALL FOUR PAWS, BLACK NOSE, BLACK EYEBROWS, BLACK EYES, BLACK EARS, BLACK MOUTH, WEARING A RED AND WHITE CHECKED KERCHIEF OUTLINED IN BROWN AROUND HIS NECK. THERE IS WHITE HIGHLIGHTING ON THE BEAR'S CLAWS AND NOSE. THE BEAR IS HOLDING IN HIS RIGHT FRONT PAW A TRIPLE-LAYERED ICE CREAM SUNDAE IN A LIGHT BLUE AND WHITE STRIPED CUP WITH GRAY SHADING. THE SUNDAE HAS A RED CHERRY ON TOP WITH BLACK SHADING AND A TOP LAYER OF WHITE WHIPPED CREAM WITH GRAY OUTLINING AND SHADOWING. BELOW THE WHIPPED CREAM ARE THREE SCOOPS OF ICE CREAM INTENDED TO REPRESENT VANILLA AND CHOCOLATE ICE CREAM AND RASPBERRY SHERBET COVERED IN CHOCOLATE HOT FUDGE SAUCE. ONE SCOOP IS BEIGE, ONE SCOOP IS BROWN, ONE SCOOP IS PINK AND THE HOT FUDGE SAUCE IS BLACK. THE BEAR'S OTHER FRONT PAW GRIPS A SILVER AND WHITE SPOON OUTLINED IN BLUE. THE REMAINDER OF WHITE IN THE DRAWING REPRESENTS A TRANSPARENT BACKGROUND THAT IS NOT PART OF THE MARK.

CLASS 30—STAPLE FOODS

FOR ICE CREAM, ICE CREAM-BASED CONFECTIONS, SAUCES, CHOCOLATE TOPPING, MARSHMALLOW TOPPING, CARAMEL TOPPING, AND CANDY SPRINKLES FOR CONSUMPTION ON OR OFF BRICKS-AND-MORTAR RETAIL PREMISES AND FOR WHOLESALE DISTRIBUTION (U.S. CL. 46).

FIRST USE 7-1-2011; IN COMMERCE 7-1-2011.

CLASS 43—HOTEL AND RESTAURANT SERVICES

FOR ICE CREAM PARLOR SERVICES (U.S. CLS. 100 AND 101).
FIRST USE 7-1-2011; IN COMMERCE 7-1-2011.
KIM MONINGHOFF, EXAMINING ATTORNEY

SN 85-404,167. RECREATIONAL EQUIPMENT, INC., KENT, WA. FILED 8-22-2011.

ROVA

THE MARK CONSISTS OF STANDARD CHARACTERS WITHOUT CLAIM TO ANY PARTICULAR FONT, STYLE, SIZE, OR COLOR.

THE ENGLISH TRANSLATION OF "ROVA" IS "TURNIP".

CLASS 5—PHARMACEUTICALS

FOR FIRST AID KITS; MEDICATED SUN SCREEN; INSECT REPELLENTS (U.S. CLS. 6, 18, 44, 46, 51 AND 52).

CLASS 8—HAND TOOLS

FOR KNIVES; FORKS; SPOONS; WOODEN COOKING SPOONS; MULTI-FUNCTION HAND TOOLS COMPRISED OF KNIVES, CAN OPENERS, SCREWDRIVERS, TWEEZERS, FILES, AND PLIERS (U.S. CLS. 23, 28 AND 44).

CLASS 9—ELECTRICAL AND SCIENTIFIC APPARATUS

FOR BINOCULARS; SPOTTING SCOPES; COMPUTER BAGS (U.S. CLS. 21, 23, 26, 36 AND 38).

CLASS 11—ENVIRONMENTAL CONTROL APPARATUS

FOR FLASHLIGHTS; LANTERNS; OUTDOOR PORTABLE LIGHTING PRODUCTS, NAMELY, HEADLAMPS (U.S. CLS. 13, 21, 23, 31 AND 34).

CLASS 16—PAPER GOODS AND PRINTED MATTER

FOR LUNCH BAGS (U.S. CLS. 2, 5, 22, 23, 29, 37, 38 AND 50).

CLASS 18—LEATHER GOODS

FOR SPORTS PACKS; BACKPACKS; SHOULDER BAGS; WATERPROOF SPORTS BAGS; MESSENGER BAGS; SCHOOL BAGS; TRAVEL BAGS; KNAPSACKS; TOTE BAGS; RUCKSACKS; FANNY PACKS; DUFFEL BAGS; BUSINESS CASES; ALL-PURPOSE CARRYING BAGS; PACKS FOR CARRYING HYDRATION, NAMELY, PERSONAL FLUID HYDRATION SYSTEMS COMPRISING A FLUID RESERVOIR, A DELIVERY TUBE, A MOUTHPIECE AND A CARRYING PACK; OVERNIGHT CASES; MESH SHOPPING BAGS; TEXTILE SHOPPING BAGS; HARNESS STRAPS; BRIEFCASES; LUGGAGE; DAY PACKS; ATTACHE CASES; HANDBAGS; BABY AND CHILD CARRIERS WORN ON THE BODY; BACKPACK COVERS; ACCESSORY POUCHES, NAMELY, POUCHES FOR HOLDING KEYS, LIP BALM, AND OTHER PERSONAL ITEMS; TRAVEL ACCESSORIES, NAMELY, JEWELRY AND COSMETIC BAGS FOR TRAVEL, SOLD EMPTY; GYM BAGS; WALLETS; PURSES; WHEELED DUFFEL BAGS; CLIMBING PACKS; HIKING STICKS; WALKING STICKS; STRAPS, NAMELY, SHOULDER STRAPS AND CARRYALL STRAPS; STUFF SACKS (U.S. CLS. 1, 2, 3, 22 AND 41).

CLASS 20—FURNITURE AND ARTICLES NOT OTHERWISE CLASSIFIED

FOR SLEEPING BAGS; PILLOWS; SLEEPING BAG PADS; INFLATABLE MATTRESSES FOR USE WHEN CAMPING; SLEEPING BAG LINERS; FURNITURE; CAMP CHAIRS; CAMP COTS; CAMP TABLES; CAMP KITCHENS, NAMELY, PORTABLE CAMP KITCHENS COMPRISED PRIMARILY OF CAMPING FURNITURE AND ALSO CONTAINING SINKS AND STORAGE SPACE; STOOLS; LOUNGERS, NAMELY, LOUNGE CHAIRS (U.S. CLS. 2, 13, 22, 25, 32 AND 50).

CLASS 21—HOUSEWARES AND GLASS

FOR POTS; PANS; MESS KITS COMPRISED OF PLATES, BOWLS, CUPS, KNIVES, SPOONS, FORKS, AND CONTAINERS FOR FOOD STORAGE; COOKING UTENSILS AND ACCESSORIES, NAMELY, WIRE BASKETS, WHISKS, SIEVES, TONGS, SPATULAS, MIXING SPOONS, SLOTTED SPOONS, SERVING SPOONS; WATER BOTTLES, NAMELY, ALUMINUM, PLASTIC, AND STAINLESS STEEL WATER BOTTLES SOLD EMPTY; WATER CONTAINERS, NAMELY, JUGS; CUPS; MUGS; INSULATED MUGS; NON-ELECTRIC COFFEE PRESSES; NON-ELECTRIC COFFEE PERCOLATORS; CHOPSTICKS; PLATES; BOWLS; HOUSEHOLD FOOD STORAGE CONTAINERS; PORTABLE COOLERS; INSULATED BAGS FOR FOOD OR BEVERAGE FOR DOMESTIC USE; COOKWARE SETS COMPRISED OF POTS, PANS, LIDS, AND COOKING UTENSILS (U.S. CLS. 2, 13, 23, 29, 30, 33, 40 AND 50).

CLASS 22—CORDAGE AND FIBERS

FOR TENTS; PORTABLE FABRIC SHELTERS; FABRIC CANOPIES; RAIN FLIES FOR TENTS; FABRIC TENT LINERS; FABRIC TENT COVERS; FABRIC GROUND CLOTHS FOR PROTECTING TENT FLOORS; MAINTENANCE KITS FOR TENTS CONSISTING OF PATCHES AND SEALANTS; UNFITTED TARPS; AWNINGS; HAMMOCKS (U.S. CLS. 1, 2, 7, 19, 22, 42 AND 50).

CLASS 25—CLOTHING

FOR SHIRTS; JERSEYS; T-SHIRTS; SHORTS; SOCKS; SWEATERS; TIGHTS; RAINCOATS; SKIRTS; BRAS; SPORTS BRAS; GLOVES; MITTENS; SCARVES; UNDERWEAR; BIB OVERALLS; CHILDREN'S BIB OVERALLS; GAITERS; PANTS; FOOTWEAR; BELTS; JACKETS; HEADWEAR; HATS; CAPS; SLEEPWEAR; TANK TOPS; VESTS; SUSPENDERS; PULLOVERS; INFANT SUITS, NAMELY, INFANT SNOWSUITS AND INFANT WEAR; DRESSES; CAPRIS; SWIMSUITS; SWEATSHIRTS; WATER SHORTS; BOARD SHORTS; SWIM COVERUPS; RASH GUARDS; FLIP FLOPS (U.S. CLS. 22 AND 39).

ESTHER BELENKER, EXAMINING ATTORNEY

SN 85-404,443. NATIONAL OVARIAN CANCER COALITION, INC., PLEASANTON, CA. FILED 8-23-2011.

TEAL INITIATIVE

THE MARK CONSISTS OF STANDARD CHARACTERS WITHOUT CLAIM TO ANY PARTICULAR FONT, STYLE, SIZE, OR COLOR.

NO CLAIM IS MADE TO THE EXCLUSIVE RIGHT TO USE "INITIATIVE", APART FROM THE MARK AS SHOWN.

CLASS 35—ADVERTISING AND BUSINESS

FOR ASSOCIATION SERVICES, NAMELY, PROMOTING THE INTERESTS OF THOSE WITH OVARIAN CANCER (U.S. CLS. 100, 101 AND 102).

FIRST USE 11-0-2009; IN COMMERCE 11-0-2009.

CLASS 44—MEDICAL, BEAUTY AND AGRICULTURAL SERVICES

FOR PROVIDING MEDICAL INFORMATION REGARDING OVARIAN CANCER TREATMENT AND THE DETECTION AND MANAGEMENT OF RELATED SYMPTOMS IN ORDER TO IMPROVE THE SURVIVAL RATE AND QUALITY OF LIFE FOR WOMEN WITH OVARIAN CANCER (U.S. CLS. 100 AND 101).

FIRST USE 11-0-2009; IN COMMERCE 11-0-2009.

CLASS 45—PERSONAL AND LEGAL SERVICES

FOR PROVIDING INFORMATION ABOUT HOW TO DEAL WITH AND PROCESS PERSONAL EMOTIONS RELATED TO OVARIAN CANCER TREATMENT IN ORDER TO IMPROVE THE SURVIVAL RATE AND QUALITY OF LIFE FOR WOMEN WITH OVARIAN CANCER (U.S. CLS. 100 AND 101).

FIRST USE 11-0-2009; IN COMMERCE 11-0-2009.

RON FAIRBANKS, EXAMINING ATTORNEY

SN 85-404,683. TRANSNET LIMITED, JOHANNESBURG, GAUTENG, SOUTH AFRICA, FILED 8-23-2011.



THE MARK CONSISTS OF AN OVAL CONTAINING A STYLIZED CURSIVE CAPITAL LETTER "B" WITH LINES OF THE BOTTOM AND TOP OF THE LETTER FORMING SEMI-CIRCLES AROUND LETTER.

CLASS 35—ADVERTISING AND BUSINESS

FOR ADVERTISING, PUBLICITY, PUBLIC RELATIONS, MARKETING AND PROMOTIONAL SERVICES (U.S. CLS. 100, 101 AND 102).

CLASS 39—TRANSPORTATION AND STORAGE

FOR TRANSPORTATION OF PASSENGERS AND GOODS BY RAIL, AIR, ROAD AND SEA; RAILWAY TRANSPORTATION, NAMELY, PASSENGER TRANSPORTATION, AND TRANSPORTATION OF GOODS AND STORAGE OF GOODS, INCLUDING CARS AND VEHICLES; WAREHOUSE STORAGE OF GOODS; TOURISM AND TRAVEL SERVICES, NAMELY, TRAVEL ARRANGEMENT, TRAVEL INFORMATION, MAKING RESERVATIONS AND BOOKINGS FOR TRANSPORTATION, INCLUDING TRAVEL RESERVATION, TICKET BOOKING SERVICES FOR TRAVEL; ARRANGING AND BOOKING OF TRAVEL PACKAGES INCORPORATING TRAIN JOURNEYS; PROVIDING ADVICE AND INFORMATION ABOUT AND ORGANIZATION OF TOURS AND EXCURSIONS (U.S. CLS. 100 AND 105).

ANTHONY RINKER, EXAMINING ATTORNEY

SN 85-405,393. WAKO, INC., DBA WAKO, INC., TOKYO, JAPAN, FILED 8-23-2011.



OWNER OF JAPAN REG. NO. 5429325, DATED 7-29-2011, EXPIRES 7-29-2021.

THE MARK CONSISTS OF A PERFUME BOTTLE DRAWN IN A PEN AND INK STYLE. THE BOTTLE IS A CIRCULAR SHAPE WITH A BASE AND A SMALL MOUTH WITH CRYSTAL STYLE SPHERICAL CAP. THE MOUTH OF THE BOTTLE IS WRAPPED WITH TASSELS THAT HANG TO THE RIGHT. THE FRONT OF THE BOTTLE HAS A CIRCULAR FLORAL DESIGN.

CLASS 18—LEATHER GOODS

FOR CARGO BAGS, HAND BAGS, COSMETIC BAGS, UMBRELLAS, TRAVELING LEATHER CASES (U.S. CLS. 1, 2, 3, 22 AND 41).

CLASS 25—CLOTHING

FOR WOMEN'S CLOTHING, NAMELY, DRESSES, SKIRTS, PANTS, TOPS, COATS, JACKETS, GARTERS, SUSPENDERS, WAIST BANDS, BELTS, FOOTWEAR, SPORTSWEAR, NAMELY, TOPS, PANTS JACKETS, SPORTS SHOES (U.S. CLS. 22 AND 39).

RAUL CORDOVA, EXAMINING ATTORNEY

SN 85-407,608. KIMBERLY J. CASPARE, DOCTOR OF PHYSICAL THERAPY, PLLC, NEW YORK, NY. FILED 8-25-2011.

**PHLEX HEALTH AND WELLNESS
STUDIO**

THE MARK CONSISTS OF STANDARD CHARACTERS WITHOUT CLAIM TO ANY PARTICULAR FONT, STYLE, SIZE, OR COLOR.

NO CLAIM IS MADE TO THE EXCLUSIVE RIGHT TO USE "HEALTH AND WELLNESS STUDIO", APART FROM THE MARK AS SHOWN.

CLASS 41—EDUCATION AND ENTERTAINMENT

FOR PHYSICAL FITNESS STUDIO SERVICES, NAMELY, PROVIDING EXERCISE CLASSES, BODY SCULPTING CLASSES, GROUP EXERCISE FITNESS CLASSES, INDIVIDUAL TRAINING EXERCISE SESSIONS, YOGA CLASSES AND PILATES CLASSES; PROVIDING EDUCATIONAL SERVICES, NAMELY, CONDUCTING TRAINING SESSIONS, WORKSHOPS AND SEMINARS IN THE FIELD OF NUTRITION (U.S. CLS. 100, 101 AND 107).
FIRST USE 5-16-2011; IN COMMERCE 5-16-2011.

CLASS 44—MEDICAL, BEAUTY AND AGRICULTURAL SERVICES

FOR PHYSICAL THERAPY, MESSAGE THERAPY SERVICES, ACUPUNCTURE AND PROVIDING INFORMATION IN THE FIELD OF NUTRITION (U.S. CLS. 100 AND 101).

FIRST USE 5-16-2011; IN COMMERCE 5-16-2011.
MICHAEL LITZAU, EXAMINING ATTORNEY

SN 85-407,757. INTERNATIONAL BACCALAUREATE ORGANIZATION (IBO), LE GRAND-SACONNEX, SWITZERLAND, FILED 8-25-2011.



OWNER OF U.S. REG. NOS. 3,643,634 AND 3,655,038.
THE MARK CONSISTS OF THE LETTERING "IB" INSIDE A CIRCLE DESIGN THAT IS PARTIALLY SHADED IN A CRESCENT SHAPE.

CLASS 14—JEWELRY

FOR PRECIOUS METALS AND THEIR ALLOYS AND GOODS MADE OF OR COATED WITH THESE MATERIALS NOT INCLUDED IN OTHER CLASSES, NAMELY, MEDALLIONS, KEY RINGS; JEWELLERY (U.S. CLS. 2, 27, 28 AND 50).

FIRST USE 4-0-2007; IN COMMERCE 4-0-2007.

CLASS 16—PAPER GOODS AND PRINTED MATTER

FOR PAPER, CARDBOARD; NOTE PADS; ADHESIVE NOTE PADS; CALENDARS; PRINTED TIMETABLES; PRINTED PUBLICATIONS, NAMELY, NEWSLETTERS, PERIODICALS, BOOKLETS, BROCHURES, CATALOGS, BOOKS AND MAGAZINES ON THE SUBJECT OF TEACHER TRAINING, EDUCATION, EDUCATIONAL EXAM PREPARATION, AND TECHNICAL SUBJECT GUIDES FOR ELEMENTARY, MIDDLE AND SECONDARY SCHOOL TEACHERS; PERSONAL ORGANIZERS; NEWSPAPERS; POSTERS; PHOTOGRAPHS; STATIONERY; PENS; PEN CASES; PLASTIC AND PAPER PACKAGING MATERIALS, NAMELY, PLASTIC AND/OR PAPER BAGS AND SACKS FOR WRAPPING (U.S. CLS. 2, 5, 22, 23, 29, 37, 38 AND 50).

FIRST USE 4-0-2007; IN COMMERCE 4-0-2007.

CLASS 18—LEATHER GOODS

FOR SCHOOL BAGS, RUCKSACKS, TRAVELLING BAGS, SPORTS BAGS (U.S. CLS. 1, 2, 3, 22 AND 41).

FIRST USE 4-0-2007; IN COMMERCE 4-0-2007.

CLASS 25—CLOTHING

FOR CLOTHING, NAMELY, T-SHIRTS, PULLOVERS, STOLE; HEADGEAR, NAMELY, HATS AND CAPS (U.S. CLS. 22 AND 39).

FIRST USE 4-0-2007; IN COMMERCE 4-0-2007.

CLASS 41—EDUCATION AND ENTERTAINMENT

FOR EDUCATIONAL SERVICES, NAMELY, PROVIDING TRAINING FOR TEACHERS IN THE FIELD OF PRIMARY AND SECONDARY EDUCATION, AND PROVIDING SEMINARS AND COURSES OF INSTRUCTION AT THE PRIMARY AND SECONDARY LEVELS FOR STUDENTS AGED THREE TO NINETEEN, AND DISTRIBUTING COURSE MATERIAL IN CONNECTION THEREWITH; EDUCATIONAL EXAMINATIONS; BOARDING SCHOOLS (U.S. CLS. 100, 101 AND 107).

FIRST USE 4-0-2007; IN COMMERCE 4-0-2007.

VERNA BETH RIRIE, EXAMINING ATTORNEY

SN 85-407,789. GILLIAM, JOSANNE, LAKE MARY, FL. FILED 8-25-2011.

**TRASH K.O.P.S. KEEP OUR
PLANET SAFE**

THE MARK CONSISTS OF STANDARD CHARACTERS WITHOUT CLAIM TO ANY PARTICULAR FONT, STYLE, SIZE, OR COLOR.

CLASS 25—CLOTHING

FOR CLOTHING, NAMELY, T-SHIRTS, HOODED SWEATSHIRTS, AND HATS (U.S. CLS. 22 AND 39).

CLASS 41—EDUCATION AND ENTERTAINMENT

FOR PROVIDING A WEBSITE FEATURING EDUCATIONAL RESOURCES IN THE NATURE OF NON-DOWNLOADABLE PUBLICATIONS IN THE FIELD OF RECYCLING (U.S. CLS. 100, 101 AND 107).

BARBARA BROWN, EXAMINING ATTORNEY

SN 85-407,820. FOOTAGE FIRM, INC., RESTON, VA. FILED 8-25-2011.

VIDEO BLOCKS

THE MARK CONSISTS OF STANDARD CHARACTERS WITHOUT CLAIM TO ANY PARTICULAR FONT, STYLE, SIZE, OR COLOR.

NO CLAIM IS MADE TO THE EXCLUSIVE RIGHT TO USE "VIDEO", APART FROM THE MARK AS SHOWN.

CLASS 9—ELECTRICAL AND SCIENTIFIC APPARATUS

FOR DOWNLOADABLE MULTIMEDIA FILES FEATURING STOCK VIDEO CLIPS, STOCK PHOTOS, STOCK MUSIC RECORDINGS, LOOPING BACKGROUNDS AND SPECIAL EFFECTS (U.S. CLS. 21, 23, 26, 36 AND 38).

FIRST USE 1-1-2009; IN COMMERCE 4-6-2009.

CLASS 41—EDUCATION AND ENTERTAINMENT

FOR TRAINING SERVICES IN THE FIELD OF VIDEO EDITING; PROVIDING ON-LINE TRAINING COURSES, SEMINARS, TUTORIALS AND WORKSHOPS IN THE FIELD OF VIDEO EDITING (U.S. CLS. 100, 101 AND 107).

FIRST USE 1-1-2009; IN COMMERCE 4-6-2009.
ANGELA M. MICHELL, EXAMINING ATTORNEY

SN 85-408,143. NIKKATSU CORPORATION, TOKYO, JAPAN, FILED 8-26-2011.



THE MARK CONSISTS OF THE WORDING "SUSHI TYPHOON" STYLIZED AND PLACED IN THE CENTER WITH WINGS AFFIXED TO AND PROTRUDING FROM THE RIGHT AND LEFT SIDE OF THE "SUSHI TYPHOON" WORDING.

CLASS 25—CLOTHING

FOR T-SHIRTS (U.S. CLS. 22 AND 39).

CLASS 28—TOYS AND SPORTING GOODS

FOR APPARATUS FOR ELECTRONIC GAMES OTHER THAN THOSE ADAPTED FOR USE WITH AN EXTERNAL DISPLAY SCREEN OR MONITOR; ARCADE GAME MACHINES; ARCADE-TYPE ELECTRONIC VIDEO GAMES; COIN-OPERATED VIDEO GAMES; COIN-OPERATED VIDEO GAMES AND GAME PROGRAMS THEREOF SOLD AS A SINGLE UNIT; HAND-HELD UNITS FOR PLAYING VIDEO GAMES OTHER THAN THOSE ADAPTED FOR USE WITH AN EXTERNAL DISPLAY SCREEN OR MONITOR; HAND-HELD GAMES WITH LIQUID CRYSTAL DISPLAYS; JAPANESE DICE GAMES (SUGOROKU); KARUTA PLAYING CARDS (JAPANESE CARD GAME); PLAYING CARDS AND CARD GAMES; ROLE PLAYING GAMES; TRADING CARD GAMES (U.S. CLS. 22, 23, 38 AND 50).

ANDREA HACK, EXAMINING ATTORNEY

SN 85-408,659. AMERICAN MEDICAL MEDIA, INC., IRVINE, CA. FILED 8-26-2011.



NO CLAIM IS MADE TO THE EXCLUSIVE RIGHT TO USE "THE PHYSICIAN'S GUIDE", APART FROM THE MARK AS SHOWN.

THE MARK CONSISTS OF THE UPPER CASE LETTERS "PG" IN ENCASED IN A SQUARE AND THE WORDS THE PHYSICIAN'S GUIDE IN LOWER CASE BESIDE THE SQUARE.

CLASS 35—ADVERTISING AND BUSINESS

FOR PROVIDING A WEBSITE CONNECTING SELLERS AND BUYERS OF USED MEDICAL DEVICES (U.S. CLS. 100, 101 AND 102).

FIRST USE 8-22-2011; IN COMMERCE 8-22-2011.

CLASS 41—EDUCATION AND ENTERTAINMENT

FOR PROVIDING A WEBSITE FEATURING EDUCATIONAL INFORMATION FOR PHYSICIANS ABOUT PROFESSIONAL MEETINGS AND CONFERENCES IN THE FIELD OF DERMATOLOGY, PLASTIC SURGERY AND AESTHETIC MEDICINE (U.S. CLS. 100, 101 AND 107).

CLASS 44—MEDICAL, BEAUTY AND AGRICULTURAL SERVICES

FOR PROVIDING A WEBSITE FEATURING INFORMATION REGARDING MEDICAL DEVICES USED IN PLASTIC AND DERMATOLOGICAL SURGERY (U.S. CLS. 100 AND 101).

FIRST USE 8-22-2011; IN COMMERCE 8-22-2011.
DEZMONA MIZELLE, EXAMINING ATTORNEY

SN 85-408,731. HOMER T. HAYWARD LUMBER COMPANY, INC., MONTEREY, CA. FILED 8-26-2011.

HAYWARD HEALTHY HOME

THE MARK CONSISTS OF STANDARD CHARACTERS WITHOUT CLAIM TO ANY PARTICULAR FONT, STYLE, SIZE, OR COLOR.

OWNER OF U.S. REG. NOS. 2,876,392 AND 3,779,203.
NO CLAIM IS MADE TO THE EXCLUSIVE RIGHT TO USE "HOME" IN INTERNATIONAL CLASSES 6 AND 19 AND "HEALTHY HOME" IN INTERNATIONAL CLASS 37, APART FROM THE MARK AS SHOWN.

CLASS 6—METAL GOODS

FOR METAL BUILDING MATERIALS, NAMELY, FLASHING, FASCIA, CEILING BOARDS, FLOOR BOARDS (U.S. CLS. 2, 12, 13, 14, 23, 25 AND 50).

CLASS 19—NON-METALLIC BUILDING MATERIALS

FOR NON-METAL BUILDING MATERIALS, NAMELY, FLY ASH, SEMI-WORKED WOODS, STONE, TIMBER, GLASS (U.S. CLS. 1, 12, 33 AND 50).

CLASS 37—CONSTRUCTION AND REPAIR

FOR CONSULTATION SERVICES IN THE FIELD OF CONSTRUCTION OF ENVIRONMENTALLY-CONSCIOUS BUILDINGS (U.S. CLS. 100, 103 AND 106).
WILLIAM BRECKENFELD, EXAMINING ATTORNEY

SN 85-409,323. STRATEGIC PLANNING SERVICES, L.L.C., REISTERSTOWN, MD. FILED 8-29-2011.

THE WEALTHFACTOR ADVANTAGE

THE MARK CONSISTS OF STANDARD CHARACTERS WITHOUT CLAIM TO ANY PARTICULAR FONT, STYLE, SIZE, OR COLOR.

CLASS 35—ADVERTISING AND BUSINESS

FOR BUSINESS SUCCESSION PLANNING (U.S. CLS. 100, 101 AND 102).
FIRST USE 8-25-2011; IN COMMERCE 8-25-2011.

CLASS 36—INSURANCE AND FINANCIAL

FOR INVESTMENT ADVISORY SERVICES; FINANCIAL SERVICES, NAMELY, WEALTH MANAGEMENT SERVICES; FINANCIAL PLANNING; FINANCIAL PLANNING FOR RETIREMENT; LIFE INSURANCE COUNSELING; EXECUTIVE BENEFITS CONSULTING SERVICES IN THE FIELD OF INSURANCE AND FINANCIAL BENEFITS; FINANCIAL TRUST AND ESTATE PLANNING AND ADVISORY SERVICES; ADVISORY SERVICES IN THE FIELD OF EMPLOYEE BENEFITS FOR GROUP HEALTHCARE AND BUSINESS INSURANCE OFFERED TO EMPLOYEES IN ADDITION TO STANDARD BENEFITS SUCH AS MEDICAL, DENTAL, LIFE INSURANCE INCLUDING SHORT TERM DISABILITY, LONG TERM DISABILITY, AND CHARITABLE GIVING STRATEGIES THROUGH FINANCIAL AND ESTATE PLANNING (U.S. CLS. 100, 101 AND 102).
FIRST USE 8-25-2011; IN COMMERCE 8-25-2011.
BARBARA RUTLAND, EXAMINING ATTORNEY

SN 85-409,595. NEPHRON PHARMACEUTICALS CORPORATION, ORLANDO, FL. FILED 8-29-2011.



NO CLAIM IS MADE TO THE EXCLUSIVE RIGHT TO USE "PHARMACEUTICALS CORPORATION", APART FROM THE MARK AS SHOWN.

THE MARK CONSISTS OF THE PHRASE "NEPHRON PHARMACEUTICALS CORPORATION" NEXT TO A DESIGN COMPRISING BEAKERS.

CLASS 5—PHARMACEUTICALS

FOR (BASED ON USE IN COMMERCE) INHALED PHARMACEUTICAL PREPARATIONS FOR THE TREATMENT OF RESPIRATORY DISEASES AND DISORDERS; (BASED ON INTENT TO USE) PHARMACEUTICAL PREPARATIONS FOR THE TREATMENT AND PREVENTION OF OTIC DISEASES AND CONDITIONS AND EYE DISEASES AND CONDITIONS (U.S. CLS. 6, 18, 44, 46, 51 AND 52).
FIRST USE 9-30-1997; IN COMMERCE 9-30-1997.

CLASS 10—MEDICAL APPARATUS

FOR NEBULIZER FOR ADMINISTERING MEDICATION IN THE FORM OF A MIST INHALED INTO THE LUNGS, FOR TREATMENT OF RESPIRATORY DISEASES (U.S. CLS. 26, 39 AND 44).
ERNEST SHOSHO, EXAMINING ATTORNEY

SN 85-410,113. ASSA ABLOY AB, STOCKHOLM, SWEDEN, FILED 8-29-2011.



THE COLOR(S) RED, DARK RED, AND WHITE IS/ARE CLAIMED AS A FEATURE OF THE MARK.

THE MARK CONSISTS OF THE OUTLINE OF TWO HANDS IN WHITE SHAKING WITHIN A SOLID RED CIRCLE OUTLINED IN DARK RED.

CLASS 9—ELECTRICAL AND SCIENTIFIC APPARATUS

FOR COMPUTER SOFTWARE FOR ISSUING AND MANAGING ENCRYPTED AND DIGITALLY SIGNED AND AUTHENTICATED IDENTITY REPRESENTATION DATA FOR USE IN THE FIELD OF PHYSICAL AND LOGICAL ACCESS CONTROL, STORED VALUE TRANSACTIONS, TRANSACTIONS INVOLVING SECURE IDENTITY, AND TRANSACTIONS INVOLVING BIOMETRIC DATA; COMPUTER SOFTWARE FOR GENERATING AND MANAGING SECURE IDENTITY REPRESENTATION DATA (U.S. CLS. 21, 23, 26, 36 AND 38).

CLASS 42—SCIENTIFIC AND COMPUTER SERVICES

FOR DATA ENCRYPTION SERVICES FOR IDENTITY REPRESENTATION DATA FOR OTHERS (U.S. CLS. 100 AND 101).

CLASS 45—PERSONAL AND LEGAL SERVICES

FOR DATA LIFECYCLE MANAGEMENT SERVICES FOR OTHERS, NAMELY, ISSUANCE, TRACKING, REVOKING, VALIDATING AND AUTHENTICATING DIGITAL CERTIFICATES AND DIGITAL CREDENTIALS; DIGITAL SIGNATURE AUTHENTICATION SERVICES FOR IDENTITY REPRESENTATION DATA FOR OTHERS, NAMELY, ISSUANCE, TRACKING, REVOKING, VALIDATING AND AUTHENTICATING DIGITAL CERTIFICATES AND DIGITAL CREDENTIALS; PROVIDING FOR OTHERS ENCRYPTED AND DIGITALLY SIGNED AND AUTHENTICATED IDENTITY REPRESENTATION DATA FOR USE IN ELECTRONIC PHYSICAL ACCESS CONTROL AND LOGICAL ACCESS CONTROL STORED VALUE TRANSACTIONS, TRANSACTIONS INVOLVING SECURE IDENTITY, AND TRANSACTIONS INVOLVING BIOMETRIC DATA, NAMELY, ISSUANCE, TRACKING, REVOKING, VALIDATING AND AUTHENTICATING DIGITAL CERTIFICATES AND DIGITAL CREDENTIALS (U.S. CLS. 100 AND 101).

JAMES STEIN, EXAMINING ATTORNEY

SN 85-410,409. NADA TESORO ESPERANZA, SAN DIEGO, CA. FILED 8-30-2011.

OMSHANTEA FOR THE YOGA SOUL

THE MARK CONSISTS OF STANDARD CHARACTERS WITHOUT CLAIM TO ANY PARTICULAR FONT, STYLE, SIZE, OR COLOR.

CLASS 16—PAPER GOODS AND PRINTED MATTER

FOR BOOKS IN THE FIELD OF INSPIRATIONAL AND UPLIFTING PERSONAL YOGA STORIES; SERIES OF BOOKS IN THE FIELD OF INSPIRATIONAL AND UPLIFTING PERSONAL YOGA STORIES (U.S. CLS. 2, 5, 22, 23, 29, 37, 38 AND 50).

CLASS 41—EDUCATION AND ENTERTAINMENT

FOR ON-LINE JOURNALS, NAMELY, BLOGS IN THE FIELDS OF INSPIRATIONAL AND UPLIFTING PERSONAL YOGA STORIES, YOGA TIPS, YOGA INFORMATION AND YOGA INFORMATION IN THE NATURE OF GENERAL DISCUSSION ABOUT YOGA PRODUCTS; PROVIDING INFORMATION IN THE FIELDS OF YOGA INSTRUCTION AND YOGA TIPS (U.S. CLS. 100, 101 AND 107).

DORITT L. CARROLL, EXAMINING ATTORNEY

SN 85-411,100. WEISS, YINON, CAMBRIDGE, MA. FILED 8-30-2011.

MilitaryToBusiness

THE MARK CONSISTS OF STANDARD CHARACTERS WITHOUT CLAIM TO ANY PARTICULAR FONT, STYLE, SIZE, OR COLOR.

CLASS 35—ADVERTISING AND BUSINESS

FOR CONSULTING SERVICES RELATED TO PRIVATE SECTOR EMPLOYMENT HIRING, RECRUITING, PLACEMENT, STAFFING AND CAREER NETWORKING SERVICES (U.S. CLS. 100, 101 AND 102).

FIRST USE 4-5-2009; IN COMMERCE 5-15-2011.

CLASS 41—EDUCATION AND ENTERTAINMENT

FOR CONSULTING SERVICES RELATED TO CAREER COUNSELING SERVICES IN THE NATURE OF PROVIDING ADVICE CONCERNING EDUCATION OPTIONS TO PURSUE PRIVATE SECTOR CAREER OPPORTUNITIES (U.S. CLS. 100, 101 AND 107).

FIRST USE 4-5-2009; IN COMMERCE 5-15-2011.

MARILYN IZZI, EXAMINING ATTORNEY

SN 85-412,372. NEXTCELL MEDICAL COMPANY, PITTSBURGH, PA. FILED 8-31-2011.

NEXTCELL

THE MARK CONSISTS OF STANDARD CHARACTERS WITHOUT CLAIM TO ANY PARTICULAR FONT, STYLE, SIZE, OR COLOR.

CLASS 3—COSMETICS AND CLEANING PREPARATIONS

FOR SKIN CARE PRODUCTS, NAMELY, NON-MEDICATED SKIN CARE PREPARATIONS, NON-MEDICATED SKIN CREAMS AND LOTIONS (U.S. CLS. 1, 4, 6, 50, 51 AND 52).

CLASS 5—PHARMACEUTICALS

FOR DIETARY SUPPLEMENTS; VITAMIN SUPPLEMENTS; MEDICATED SKIN CARE PREPARATIONS (U.S. CLS. 6, 18, 44, 46, 51 AND 52).

CLASS 35—ADVERTISING AND BUSINESS

FOR DISTRIBUTORSHIP SERVICES IN THE FIELD OF DIETARY SUPPLEMENTS, SKIN CARE PREPARATIONS, VITAMIN SUPPLEMENTS (U.S. CLS. 100, 101 AND 102).

DAVID ELTON, EXAMINING ATTORNEY

SN 85-412,893. FEAR OF GOD, LLC, STUDIO CITY, CA. FILED 9-1-2011.



THE MARK CONSISTS OF CUSTOM FONT: "FEAR OF GOD".

CLASS 14—JEWELRY

FOR (BASED ON USE IN COMMERCE) BRACELETS; JEWELRY, NAMELY, BRACELETS, WRISTBANDS AND NECKLACES THAT ALSO PROVIDES NOTIFICATION TO THE WEARER OF A PENDING MEDICAL RELATED TASK; JEWELRY, NAMELY, CROSSES (BASED ON INTENT TO USE) CHARMS FOR COLLAR JEWELRY AND BRACELET; COSTUME JEWELRY; HAIR JEWELRY IN THE NATURE OF JEWELRY FOR USE IN THE HAIR; INEXPENSIVE NON-JEWELRY WATCHES; JEWELRY; JEWELRY CHAINS; JEWELRY FOR ATTACHMENT TO CLOTHING; JEWELRY WATCHES; JEWELRY, NAMELY, ANKLETS; JEWELRY, NAMELY, MAGNETIC NECKLACES; LEATHER JEWELRY AND ACCESSORY BOXES; PET JEWELRY; PLASTIC BRACELETS IN THE NATURE OF JEWELRY; PRECIOUS AND SEMI-PRECIOUS CRYSTAL STONES AND BEADS FOR USE IN JEWELRY; RINGS; RINGS BEING JEWELRY; STAINLESS STEEL JEWELRY BRACELETS; WATCHES AND JEWELRY; WATCHES, CLOCKS, JEWELRY AND IMITATION JEWELRY; WOMEN'S JEWELRY (U.S. CLS. 2, 27, 28 AND 50).

FIRST USE 4-1-2011; IN COMMERCE 4-1-2011.

CLASS 25—CLOTHING

FOR (BASED ON USE IN COMMERCE) BELTS FOR CLOTHING; TOPS; WEARABLE GARMENTS AND CLOTHING, NAMELY, SHIRTS (BASED ON INTENT TO USE) ADULT NOVELTY GAG CLOTHING ITEM, NAMELY, SOCKS; BELTS; BOTTOMS; CLOTHING EXTENSION USED TO EXTEND THE NORMAL SIZE RANGE OF CLOTHING ITEMS TO ACCOMMODATE PREGNANCY SIZE CHANGES; CLOTHING FOR BABIES, TODDLERS AND CHILDREN, TREATED WITH FIRE AND HEAT RETARDANTS, NAMELY, PAJAMAS, JACKETS, SHIRTS, PANTS, JUMPERS; CLOTHING ITEMS, NAMELY, ADHESIVE POCKETS THAT MAY BE AFFIXED DIRECTLY TO THE BODY AS A DECORATIVE PIECE OF CLOTHING WITH UTILITY; CLOTHING ITEMS, NAMELY, ADHESIVE POCKETS THAT MAY BE AFFIXED DIRECTLY TO THE INSIDE OF CLOTHING FOR STORAGE AND SAFEKEEPING OF PERSONAL ITEMS; CLOTHING, NAMELY, KHAKIS; EYESHADES; GLOVES AS CLOTHING; INFANT AND TODDLER ONE PIECE CLOTHING; JACKETS; JERSEYS; LEATHER BELTS; MATERNITY CLOTHING, NAMELY, SHIRTS, PANTS, SHORTS, TOPS, SWEATER; SHORT SETS; TIES; WOMEN'S CLOTHING, NAMELY, SHIRTS, DRESSES, SKIRTS, BLOUSES; WRAPS (U.S. CLS. 22 AND 39).

FIRST USE 4-1-2011; IN COMMERCE 4-1-2011.

CHARLOTTE CORWIN, EXAMINING ATTORNEY

SN 85-412,915. NEXTCELL MEDICAL COMPANY, PITTSBURGH, PA. FILED 9-1-2011.



THE MARK CONSISTS OF THE WORD "NEXTCELL" WITH AN ARROW FORMING PART OF THE LETTERS "X" AND "T" IN THE WORD.

CLASS 3—COSMETICS AND CLEANING PREPARATIONS

FOR SKIN CARE PRODUCTS, NAMELY, NON-MEDICATED SKIN CARE PREPARATIONS, NON-MEDICATED SKIN CREAMS AND LOTIONS (U.S. CLS. 1, 4, 6, 50, 51 AND 52).

CLASS 5—PHARMACEUTICALS

FOR DIETARY SUPPLEMENTS; VITAMIN SUPPLEMENTS; MEDICATED SKIN CARE PREPARATIONS (U.S. CLS. 6, 18, 44, 46, 51 AND 52).

CLASS 35—ADVERTISING AND BUSINESS

FOR DISTRIBUTORSHIP SERVICES IN THE FIELD OF DIETARY SUPPLEMENTS, SKIN CARE PREPARATIONS, VITAMIN SUPPLEMENTS (U.S. CLS. 100, 101 AND 102).

DAVID ELTON, EXAMINING ATTORNEY

SN 85-413,593. THE HAPPIEST BABY, INC., LOS ANGELES, CA. FILED 9-1-2011.

SN 85-413,934. THE REGULATORY FUNDAMENTALS GROUP LLC, NEW YORK, NY. FILED 9-2-2011.

THE HAPPIEST BABY

THE MARK CONSISTS OF STANDARD CHARACTERS WITHOUT CLAIM TO ANY PARTICULAR FONT, STYLE, SIZE, OR COLOR.

OWNER OF U.S. REG. NOS. 3,318,991, 3,434,465 AND 3,851,032.

NO CLAIM IS MADE TO THE EXCLUSIVE RIGHT TO USE "BABY", APART FROM THE MARK AS SHOWN.

CLASS 20—FURNITURE AND ARTICLES NOT OTHERWISE CLASSIFIED

FOR FURNITURE, CRIBS, DRESSERS, FURNITURE CHESTS, TOY CHESTS, CHANGING TABLES, CHAIRS, TABLES, DESKS, AND BEDS (U.S. CLS. 2, 13, 22, 25, 32 AND 50).

CLASS 28—TOYS AND SPORTING GOODS

FOR BABY SWINGS (U.S. CLS. 22, 23, 38 AND 50).
WILLIAM JACKSON, EXAMINING ATTORNEY

RFG REGISTRATION PRO

THE MARK CONSISTS OF STANDARD CHARACTERS WITHOUT CLAIM TO ANY PARTICULAR FONT, STYLE, SIZE, OR COLOR.

NO CLAIM IS MADE TO THE EXCLUSIVE RIGHT TO USE "REGISTRATION PRO", APART FROM THE MARK AS SHOWN.

CLASS 35—ADVERTISING AND BUSINESS

FOR BUSINESS RISK MANAGEMENT CONSULTING (U.S. CLS. 100, 101 AND 102).
FIRST USE 7-29-2011; IN COMMERCE 7-29-2011.

CLASS 45—PERSONAL AND LEGAL SERVICES

FOR REGULATORY COMPLIANCE CONSULTING FOR BUSINESS; TRACKING AND MONITORING REGULATORY REQUIREMENTS FOR BUSINESS FOR REGULATORY COMPLIANCE PURPOSES (U.S. CLS. 100 AND 101).
FIRST USE 7-29-2011; IN COMMERCE 7-29-2011.
H. M. FISHER, EXAMINING ATTORNEY

SN 85-413,898. THE REGULATORY FUNDAMENTALS GROUP LLC, NEW YORK, NY. FILED 9-2-2011.

SN 85-413,957. THE REGULATORY FUNDAMENTALS GROUP LLC, NEW YORK, NY. FILED 9-2-2011.

RFG PATHFINDER

THE MARK CONSISTS OF STANDARD CHARACTERS WITHOUT CLAIM TO ANY PARTICULAR FONT, STYLE, SIZE, OR COLOR.

CLASS 35—ADVERTISING AND BUSINESS

FOR BUSINESS RISK MANAGEMENT CONSULTING (U.S. CLS. 100, 101 AND 102).
FIRST USE 8-8-2011; IN COMMERCE 8-8-2011.

CLASS 45—PERSONAL AND LEGAL SERVICES

FOR REGULATORY COMPLIANCE CONSULTING FOR BUSINESS; TRACKING AND MONITORING REGULATORY REQUIREMENTS FOR BUSINESS FOR REGULATORY COMPLIANCE PURPOSES (U.S. CLS. 100 AND 101).
FIRST USE 8-8-2011; IN COMMERCE 8-8-2011.
H. M. FISHER, EXAMINING ATTORNEY

RFG WATCH

THE MARK CONSISTS OF STANDARD CHARACTERS WITHOUT CLAIM TO ANY PARTICULAR FONT, STYLE, SIZE, OR COLOR.

NO CLAIM IS MADE TO THE EXCLUSIVE RIGHT TO USE "WATCH", APART FROM THE MARK AS SHOWN.

CLASS 35—ADVERTISING AND BUSINESS

FOR BUSINESS RISK MANAGEMENT CONSULTING (U.S. CLS. 100, 101 AND 102).
FIRST USE 7-29-2011; IN COMMERCE 7-29-2011.

CLASS 45—PERSONAL AND LEGAL SERVICES

FOR REGULATORY COMPLIANCE CONSULTING FOR BUSINESS; TRACKING AND MONITORING REGULATORY REQUIREMENTS FOR BUSINESS FOR REGULATORY COMPLIANCE PURPOSES (U.S. CLS. 100 AND 101).
FIRST USE 7-29-2011; IN COMMERCE 7-29-2011.
H. M. FISHER, EXAMINING ATTORNEY

SN 85-415,547. DELTA DENTAL OF VIRGINIA, ROANOKE, VA. FILED 9-6-2011.

SN 85-415,573. JOHN C. SCHOEB, CHARLOTTESVILLE, VA. FILED 9-6-2011.

THAT'S THE TROOTH

THE MARK CONSISTS OF STANDARD CHARACTERS WITHOUT CLAIM TO ANY PARTICULAR FONT, STYLE, SIZE, OR COLOR.

CLASS 36—INSURANCE AND FINANCIAL

FOR DENTAL INSURANCE UNDERWRITING AND ADMINISTRATION (U.S. CLS. 100, 101 AND 102).
FIRST USE 8-5-2011; IN COMMERCE 9-3-2011.

CLASS 44—MEDICAL, BEAUTY AND AGRICULTURAL SERVICES

FOR PROVIDING INFORMATION REGARDING ORAL DISEASE AND ITS CAUSES, SYMPTOMS, AND PREVENTION (U.S. CLS. 100 AND 101).
FIRST USE 8-5-2011; IN COMMERCE 9-3-2011.
LAURIE KAUFMAN, EXAMINING ATTORNEY

SN 85-415,569. DELTA DENTAL OF VIRGINIA, ROANOKE, VA. FILED 9-6-2011.

LEARN THE TROOTH

THE MARK CONSISTS OF STANDARD CHARACTERS WITHOUT CLAIM TO ANY PARTICULAR FONT, STYLE, SIZE, OR COLOR.

CLASS 36—INSURANCE AND FINANCIAL

FOR DENTAL INSURANCE UNDERWRITING AND ADMINISTRATION (U.S. CLS. 100, 101 AND 102).
FIRST USE 8-5-2011; IN COMMERCE 9-3-2011.

CLASS 44—MEDICAL, BEAUTY AND AGRICULTURAL SERVICES

FOR PROVIDING INFORMATION REGARDING ORAL DISEASE AND ITS CAUSES, SYMPTOMS, AND PREVENTION (U.S. CLS. 100 AND 101).
FIRST USE 8-5-2011; IN COMMERCE 9-3-2011.
LAURIE KAUFMAN, EXAMINING ATTORNEY

SHOW US YOUR PHONE

THE MARK CONSISTS OF STANDARD CHARACTERS WITHOUT CLAIM TO ANY PARTICULAR FONT, STYLE, SIZE, OR COLOR.

CLASS 30—STAPLE FOODS

FOR PIZZA; PIZZAS MADE TO ORDER FOR CONSUMPTION ON OR OFF THE PREMISES; HOT PIZZAS MADE TO ORDER FOR CONSUMPTION ON OR OFF THE PREMISES; HOT BREAD STICKS FOR CONSUMPTION ON OR OFF THE PREMISES; FRESH BAKED DUMPLING-LIKE DOUGH BALLS FOR CONSUMPTION ON OR OFF THE PREMISES; CAKES, COOKIES AND PIES (U.S. CL. 46).

CLASS 39—TRANSPORTATION AND STORAGE

FOR PIZZA DELIVERY SERVICES (U.S. CLS. 100 AND 105).

CLASS 43—HOTEL AND RESTAURANT SERVICES

FOR RESTAURANT SERVICES AND CARRYOUT RESTAURANT SERVICES (U.S. CLS. 100 AND 101).
RON FAIRBANKS, EXAMINING ATTORNEY

SN 85-415,799. JOHN C. SCHOEB, CHARLOTTESVILLE, VA. FILED 9-6-2011.

SHOW ME YOUR PHONE

THE MARK CONSISTS OF STANDARD CHARACTERS WITHOUT CLAIM TO ANY PARTICULAR FONT, STYLE, SIZE, OR COLOR.

CLASS 30—STAPLE FOODS

FOR PIZZA; PIZZAS MADE TO ORDER FOR CONSUMPTION ON OR OFF THE PREMISES; HOT PIZZAS MADE TO ORDER FOR CONSUMPTION ON OR OFF THE PREMISES; HOT BREAD STICKS FOR CONSUMPTION ON OR OFF THE PREMISES; FRESH BAKED DUMPLING-LIKE DOUGH BALLS FOR CONSUMPTION ON OR OFF THE PREMISES; CAKES, COOKIES AND PIES (U.S. CL. 46).

CLASS 39—TRANSPORTATION AND STORAGE

FOR PIZZA DELIVERY SERVICES (U.S. CLS. 100 AND 105).

CLASS 43—HOTEL AND RESTAURANT SERVICES

FOR RESTAURANT SERVICES AND CARRYOUT RESTAURANT SERVICES (U.S. CLS. 100 AND 101).
RON FAIRBANKS, EXAMINING ATTORNEY

SN 85-416,556. GEO CARE, INC., BOCA RATON, FL. FILED 9-7-2011.



THE MARK CONSISTS OF THE WORD "GEO" IN BOLD-FACE WITH A GLOBAL MAP INSIDE THE LETTER "O" OF "GEO" AND THE STYLIZED WORD "CARE" IS BELOW THE LETTER "O" OF THE WORD "GEO".

CLASS 43—HOTEL AND RESTAURANT SERVICES

FOR PROVIDING CORRECTIONS SERVICES, NAMELY, SHORT- AND LONG-TERM RESIDENTIAL SERVICES TO HELP COURT-ORDERED YOUTHS, PRISONERS AND DETAINEES (U.S. CLS. 100 AND 101).
FIRST USE 9-0-2005; IN COMMERCE 9-0-2005.

CLASS 44—MEDICAL, BEAUTY AND AGRICULTURAL SERVICES

FOR REHABILITATIVE SERVICES AND TREATMENT PROGRAMS FOR JUVENILES, PRISONERS AND DETAINEES, NAMELY, PROVIDING MENTAL REHABILITATIVE SERVICES AND BEHAVIORAL HEALTH SERVICES (U.S. CLS. 100 AND 101).
FIRST USE 9-0-2005; IN COMMERCE 9-0-2005.
AMY ALFIERI, EXAMINING ATTORNEY

SN 85-416,560. GEO CARE, INC., BOCA RATON, FL. FILED 9-7-2011.



NO CLAIM IS MADE TO THE EXCLUSIVE RIGHT TO USE "GROUP COMPANY", APART FROM THE MARK AS SHOWN.

THE MARK CONSISTS OF THE WORD "ABRAXAS" IN BOLD-FACE LETTERS WITH THE WORD "A GEO GROUP COMPANY" UNDERNEATH THE WORD "ABRAXAS" AND OFFSET TO THE RIGHT. THERE IS A GLOBAL MAP DEPICTED INSIDE THE LETTER "O" OF WORD "GEO".

CLASS 43—HOTEL AND RESTAURANT SERVICES

FOR PROVIDING SHORT AND LONG-TERM RESIDENTIAL SERVICES TO HELP COURT-ORDERED YOUTHFUL MALE AND FEMALE OFFENDERS (U.S. CLS. 100 AND 101).
FIRST USE 3-7-2011; IN COMMERCE 3-7-2011.

CLASS 44—MEDICAL, BEAUTY AND AGRICULTURAL SERVICES

FOR REHABILITATIVE PATIENT CARE SERVICES WHICH INCLUDES INPATIENT CARE FOR YOUTHFUL MALE AND FEMALE OFFENDERS, NAMELY, BEHAVIORAL HEALTH SERVICES (U.S. CLS. 100 AND 101).
FIRST USE 3-7-2011; IN COMMERCE 3-7-2011.
AMY ALFIERI, EXAMINING ATTORNEY

SN 85-416,645. ASIAALUM HOLDINGS LIMITED, ROAD TOWN, TORTOLA, BR.VIRGIN ISLANDS, FILED 9-7-2011.



THE MARK CONSISTS OF A SQUARE CONTAINING A TRIANGLE, THE LETTERS "AAG", AND TWO CHINESE CHARACTERS THAT TRANSLITERATE INTO "YA LÜ".

THE NON-LATIN CHARACTERS IN THE MARK TRANSLITERATE TO "YA LÜ" AND THIS HAS NO MEANING IN A FOREIGN LANGUAGE.

CLASS 6—METAL GOODS

FOR COMMON METALS AND THEIR ALLOYS INCLUDING STAINLESS STEEL; ALUMINUM FOILS; ALUMINUM INGOTS; ARMOUR PLATE AND ARMOUR PLATING; BARS FOR METAL RAILINGS; METAL BIRD BATHS; METAL BUILDING MATERIALS, NAMELY, CEILING BOARDS AND FLOOR BOARDS; METAL BOTTLE CAPS; BOTTLE CLOSURES OF METAL; METAL BOTTLE STOPPERS; METAL CAPSULE CLOSURES FOR BOTTLES AND FLEXIBLE METAL FOILS FOR PACKAGING USED AS BOTTLE CAPS; METAL CONTAINERS FOR COMPRESSED GAS OR LIQUID AIR; BOXES OF COMMON METAL; BRAZING ALLOYS; CABANAS OF METAL; METAL CASEMENT WINDOWS; METAL CEILING MEDALLIONS; METAL CEILING TILES AND PANELS; METAL COVERINGS FOR CEILINGS; METAL CHESTS; METAL CLADDING FOR CONSTRUCTION AND BUILDING; METAL CLOSURES FOR CONTAINERS; COMMON METALS, UNWROUGHT AND SEMI-WORKED, FOR FURTHER MANUFACTURE; CONTAINERS OF METAL FOR CHEMICALS, COMPRESSED GASES AND LIQUIDS; METAL CONTAINERS FOR THE STORAGE AND TRANSPORTATION OF GOODS; METAL DOORS; DOOR CASINGS OF METAL; DOOR FITTINGS OF METAL; DOOR FRAMES OF METAL; METAL HARDWARE, NAMELY, SPRINGS; DOOR STOPS OF METAL; METAL FENCES AND GATES; METAL BUILDING FLASHING; METAL FOILS FOR WRAPPING AND PACKAGING; METAL FRAMES FOR BUILDING; FRAMEWORK OF METAL; FURNITURE FITTINGS OF METAL; METAL GREENHOUSE FRAMES; METAL HOUSE NUMBERS; IDENTITY PLATES OF COMMON METAL; INGOTS OF COMMON METAL; METAL LADDERS; METAL LATCH BAR; METAL LETTER BOXES; LININGS OF METAL FOR BUILDING PURPOSES; METAL EXTERIOR BLINDS; INDUSTRIAL PACKAGING CONTAINERS OF METAL; METAL PIPES AND METAL FITTINGS THEREFOR; PIPEWORK OF METAL INCLUDING THOSE FROM ALLOY STEEL AND TITANIUM; METAL LICENSE PLATES; METAL POLES; MATERIALS OF METAL FOR RAILWAY CONSTRUCTION; REINFORCING MATERIALS OF METAL FOR BUILDING PURPOSES; METAL RODS FOR BRAZING AND WELDING; METAL

ROOF FLASHING; METAL ROOFING; METAL ROOFING PANELS AND TILES; EXTERIOR METAL SHUTTERS, INTERIOR METAL SHUTTERS, AND METAL WINDOW SHUTTERS; UPRIGHT SIGNBOARDS OF COMMON METAL; NON-LUMINOUS AND NON-MECHANICAL METAL SIGNS; METAL ROAD SIGNS, NON-LUMINOUS AND NON-MECHANICAL; METAL STORAGE TANKS AND ROOFS THEREFOR; METAL TILES; METAL TILES FOR WALLS, CEILINGS, OR FLOORS; METAL TUBS; METAL TUBES; METAL WATER PIPES; METAL WINDOWS; WINDOW FITTINGS OF METAL; WINDOW FRAMES OF METAL; WINDOW STOPS OF METAL; ANCHORS; METAL CONCRETE CONSTRUCTION HARDWARE, NAMELY, ANCHORS AND METAL CHANNELS FOR USE IN OR EMBEDDED IN CONCRETE; AND BUILDING FASTENERS OF METAL, NAMELY, NAILS, SCREWS, BOLTS, NUTS, RIVETS, MASONRY ANCHORS, CONCRETE ANCHORS, AND WASHERS (U.S. CLS. 2, 12, 13, 14, 23, 25 AND 50).

CLASS 12—VEHICLES

FOR RAILWAY CARS; RAILWAY BOGIES; AUTOMOTIVE AFTERMARKET ACCESSORIES, NAMELY, VEHICLE CUSTOM GRILLS; AMBULANCES; AUTOMOTIVE BODIES; BODIES FOR VEHICLES; AUTOMOBILE HOODS; VEHICLE HOODS; BICYCLE FRAMES; BICYCLE HANDLEBARS; CAMPER; SELF-PROPELLED ELECTRIC VEHICLES; FERRY BOATS; MOTORIZED GOLF CARTS; LIFTING CARS; LORRIES; MILITARY VEHICLES FOR TRANSPORT; BUSES; MOTOR CARS FOR LAND TRANSPORT; MOTOR COACHES; MOTOR HOMES; MOTORCYCLES; REFRIGERATED VEHICLES; MOTORIZED SCOOTERS; SKI LIFTS; TRAILERS; TRUCKS; FITTED VEHICLE COVERS; MOTORIZED LUGGAGE CARTS; VEHICLES FOR LOCOMOTION BY LAND, AIR, WATER OR RAIL, NAMELY, SHIPS, BOATS, AIRPLANES, LAND VEHICLES, AND RAIL VEHICLES, NAMELY, TRAINS AND STRUCTURAL PARTS THEREFOR (U.S. CLS. 19, 21, 23, 31, 35 AND 44).
DOMINICK J. SALEMI, EXAMINING ATTORNEY

SN 85-417,074. CYDESIGN LABS, INC., PALO ALTO, CA. FILED 9-7-2011.

CYDESIGN

THE MARK CONSISTS OF STANDARD CHARACTERS WITHOUT CLAIM TO ANY PARTICULAR FONT, STYLE, SIZE, OR COLOR.

CLASS 9—ELECTRICAL AND SCIENTIFIC APPARATUS

FOR COMPUTER SOFTWARE, NAMELY, COMPUTER AIDED DESIGN SOFTWARE FOR USE IN THE DESIGN OF CYBER-ELECTROMECHANICAL SYSTEMS; COMPUTER SOFTWARE THAT PROVIDES WEB-BASED ACCESS TO APPLICATIONS AND SERVICES THROUGH A WEB OPERATING SYSTEM OR PORTAL INTERFACE (U.S. CLS. 21, 23, 26, 36 AND 38).

CLASS 42—SCIENTIFIC AND COMPUTER SERVICES

FOR SOFTWARE AS A SERVICE (SAAS) SERVICES, NAMELY, HOSTING SOFTWARE FOR USE BY OTHERS IN THE DESIGN OF CYBER-ELECTROMECHANICAL SYSTEMS (U.S. CLS. 100 AND 101).
MICHAEL LITZAU, EXAMINING ATTORNEY

SN 85-417,298. ALBENDESIGN LLC, SANTA CRUZ, CA. FILED 9-8-2011.

SEA CHANGE DESIGN PROCESS

THE MARK CONSISTS OF STANDARD CHARACTERS WITHOUT CLAIM TO ANY PARTICULAR FONT, STYLE, SIZE, OR COLOR.

NO CLAIM IS MADE TO THE EXCLUSIVE RIGHT TO USE "DESIGN PROCESS", APART FROM THE MARK AS SHOWN.

CLASS 35—ADVERTISING AND BUSINESS

FOR BUSINESS MANAGEMENT CONSULTING SERVICES; BUSINESS CONSULTING USING TRANSFORMATIVE DESIGN THINKING, TOOLS, AND TECHNIQUES TO SUPPORT AND ENCOURAGE TRANSFORMATIONS IN LEADERS, ORGANIZATIONS, CIVIC SOCIETY AND THE ENVIRONMENT; BUSINESS CONSULTING SERVICES IN THE FIELD OF ORGANIZATIONAL CHANGE MANAGEMENT; CONSULTING SERVICES IN THE FIELD OF BUSINESS ORGANIZATIONAL DESIGN AND BUSINESS DEVELOPMENT SERVICES; BUSINESS STRATEGY PLANNING AND DEVELOPMENT CONSULTING; CREATIVE MARKETING DESIGN SERVICES (U.S. CLS. 100, 101 AND 102).
FIRST USE 7-1-2001; IN COMMERCE 7-1-2001.

CLASS 41—EDUCATION AND ENTERTAINMENT

FOR EDUCATIONAL SERVICES, NAMELY, EXECUTIVE COACHING; PERSONAL COACHING SERVICES USING DESIGN TECHNIQUES TO PROMOTE CREATIVITY AND PROBLEM SOLVING IN THE FIELD OF ORGANIZATIONAL DEVELOPMENT; BUSINESS TRAINING IN THE FIELD OF LEADERSHIP DEVELOPMENT AND TEAM COACHING IN THE FIELD OF ORGANIZATIONAL DEVELOPMENT; EDUCATIONAL SERVICES, NAMELY, SEMINARS, COURSES AND WORKSHOPS IN THE FIELD OF PERSONAL, CULTURAL AND ORGANIZATIONAL TRANSFORMATION REGARDING PERSONAL AND ORGANIZATIONAL DEVELOPMENT (U.S. CLS. 100, 101 AND 107).

FIRST USE 7-1-2001; IN COMMERCE 7-1-2001.
RAMONA ORTIGA, EXAMINING ATTORNEY

SN 85-417,447. DELTA DENTAL OF VIRGINIA, ROANOKE, VA. FILED 9-8-2011.

THAT'S THE TROUTH

CLASS 36—INSURANCE AND FINANCIAL

FOR DENTAL INSURANCE UNDERWRITING AND ADMINISTRATION (U.S. CLS. 100, 101 AND 102).
FIRST USE 8-5-2011; IN COMMERCE 9-3-2011.

CLASS 44—MEDICAL, BEAUTY AND AGRICULTURAL SERVICES

FOR PROVIDING INFORMATION REGARDING ORAL DISEASE AND ITS CAUSES, SYMPTOMS, AND PREVENTION (U.S. CLS. 100 AND 101).
FIRST USE 8-5-2011; IN COMMERCE 9-3-2011.
LAURIE KAUFMAN, EXAMINING ATTORNEY

SN 85-417,673. MERCK KGAA, 64293 DARMSTADT, FED REP GERMANY, FILED 9-8-2011.

APURA

THE MARK CONSISTS OF STANDARD CHARACTERS WITHOUT CLAIM TO ANY PARTICULAR FONT, STYLE, SIZE, OR COLOR.

OWNER OF FED REP GERMANY REG. NO. 30093018, DATED 3-15-2001, EXPIRES 12-31-2020.

CLASS 1—CHEMICALS

FOR CHEMICALS USED IN INDUSTRY AND SCIENCE (U.S. CLS. 1, 5, 6, 10, 26 AND 46).

CLASS 9—ELECTRICAL AND SCIENTIFIC APPARATUS

FOR APPARATUS AND INSTRUMENTS FOR WATER DETERMINATION, NAMELY, LABORATORY EQUIPMENT IN THE NATURE OF TITRATORS, COULOMETERS (U.S. CLS. 21, 23, 26, 36 AND 38).

ALLISON SCHRODY, EXAMINING ATTORNEY

SN 85-417,763. CIRQUE DU SOLEIL HOLDING USA, INC., GRAND DUCHY OF LUXEMBOURG, LUXEMBOURG, FILED 9-8-2011.

AMALUNA CIRQUE DU SOLEIL

THE MARK CONSISTS OF STANDARD CHARACTERS WITHOUT CLAIM TO ANY PARTICULAR FONT, STYLE, SIZE, OR COLOR.

OWNER OF U.S. REG. NOS. 1,884,981, 1,887,187 AND 1,925,400.

THE WORDING "AMALUNA" HAS NO MEANING IN A FOREIGN LANGUAGE. THE ENGLISH TRANSLATION OF "CIRQUE DU SOLEIL" IN THE MARK IS "CIRCUS OF THE SUN".

CLASS 6—METAL GOODS

FOR METAL KEY CHAINS, METAL KEY RINGS (U.S. CLS. 2, 12, 13, 14, 23, 25 AND 50).

CLASS 9—ELECTRICAL AND SCIENTIFIC APPARATUS

FOR PRE-RECORDED MEDIA FOR THE STORAGE AND REPRODUCTION OF SOUND AND/OR VIDEO, FEATURING MUSIC AND/OR THEATRICAL OR DRAMATIC PERFORMANCES, NAMELY, AUDIO DISCS, VIDEO DISCS, COMPACT DISCS, DIGITAL VERSATILE DISKS, INTERACTIVE COMPACT DISCS, DISKETTES, MOTION PICTURE FILMS FEATURING MUSICAL, THEATRICAL AND DRAMATIC PERFORMANCES; CASES FOR HOLDING COMPACT DISCS AND DIGITAL VERSATILE DISKS; DECORATIVE MAGNETS; ENTERTAINMENT AND EDUCATIONAL SOFTWARE, NAMELY, MULTIMEDIA INTERACTIVE COMPUTER GAME SOFTWARE, MULTIMEDIA SOFTWARE RECORDED ON CD-ROM AND OTHER READ-ONLY FORMATS FEATURING ENTERTAINMENT AND/OR EDUCATION IN THE FIELDS OF MUSIC, DRAMA AND VARIETY ACTS; MUSIC, SOUND AND VIDEO RECORDING MEDIA, DOWNLOADABLE MUSIC, SOUND AND VIDEO RECORDING MEDIA; CARRYING CASES AND PROTECTIVE COVERS FOR PAGERS, PHONES, PDAS (PERSONAL DIGITAL ASSISTANTS), TABLET COMPUTERS AND MP3 PLAYERS; CELLULAR PHONE ACCESSORY CHARMS; VIDEO, COMPUTER AND ELECTRONIC GAMES (U.S. CLS. 21, 23, 26, 36 AND 38).

CLASS 14—JEWELRY

FOR JEWELRY; FINE AND COSTUME JEWELRY, NAMELY, PINS AND ORNAMENTAL PINS, BROOCHES, EARRINGS, BRACELETS, NECKLACES, RINGS, PENDANTS, CHARMS, TIE CLIPS; KEY RINGS AND KEY CHAINS OF PRECIOUS METAL OR COATED THEREWITH (U.S. CLS. 2, 27, 28 AND 50).

CLASS 16—PAPER GOODS AND PRINTED MATTER

FOR PAPER GOODS, NAMELY, MAGAZINES, BROCHURES, SOUVENIR PROGRAMS, BOOKS AND COMMEMORATIVE BOOKS REGARDING CIRCUSES, ENTERTAINMENT AND THE ARTS; POSTERS, LITHOGRAPHS, CALENDARS, DIARIES, MEMO PADS, DECALOMANIAS, COLORING BOOKS, PAINTING AND COLORING SETS FOR CHILDREN, COMIC BOOKS, STICKER BOOKS, SCRAP BOOKS, ADDRESS BOOKS, BOOKMARKS, LETTER OPENERS, PHOTO ALBUMS, APPOINTMENT BOOKS, LOOSE-LEAFS BINDERS, PAPER AND PLASTIC BAGS FOR SHOPPING, FOR PACKAGING, GENERAL PURPOSE BAGS, MERCHANDISE BAGS; PLASTIC REUSABLE TOTE BAGS; PLASTIC REUSABLE GIFT BAGS, FABRIC GIFT BAGS; STATIONERY; FRAMED PICTURES, PAINTINGS; PENS, PENCILS, DESK SETS, PEN AND PENCIL SETS; PRINTED PUBLICATIONS RELATED TO MUSIC; BOOK ENDS; PENCIL CASES; PAPERWEIGHTS; GREETING CARDS, POST CARDS, NOTE CARDS, PICTURES; AGENDAS, NOTE BOOKS, NOTE PADS (U.S. CLS. 2, 5, 22, 23, 29, 37, 38 AND 50).

CLASS 18—LEATHER GOODS

FOR BAGS AND CASES, NAMELY, TOTE BAGS, SPORTS BAGS, TRAVEL BAGS, LUGGAGE, SUITCASES, GARMENT BAGS FOR TRAVEL, TRUNKS, ATTACHE CASES, CLUTCH BAGS, HAND BAGS, SHOPPING BAGS, MESSENGER BAGS, WALLETS, PURSES, KNAPSACKS, BACK PACKS, FANNY PACKS, GYM BAGS, KEY CASES, COIN PURSES, COMBINATION WALLETS FOR CARRYING KEYS AND COINS, LEATHER AND IMITATION LEATHER ID HOLDERS, NAMELY, NAME CARD CASES; COSMETIC BAGS SOLD EMPTY, UMBRELLAS (U.S. CLS. 1, 2, 3, 22 AND 41).

CLASS 20—FURNITURE AND ARTICLES NOT OTHERWISE CLASSIFIED

FOR KEY CHAINS AND KEY RINGS NOT OF METAL (U.S. CLS. 2, 13, 22, 25, 32 AND 50).

CLASS 21—HOUSEWARES AND GLASS

FOR HOUSEHOLD AND NOVELTY ITEMS, NAMELY, MUGS, DRINKING CUPS, DRINKING GLASSES, BEVERAGE WARE, DECORATIVE AND COMMEMORATIVE PLATES AND BOWLS, DISHWARE; THEATRICAL MASKS FOR DECORATIVE PURPOSES (U.S. CLS. 2, 13, 23, 29, 30, 33, 40 AND 50).

CLASS 25—CLOTHING

FOR CLOTHING, WEARING APPAREL AND ACCESSORIES, NAMELY, SHIRTS, SWEATSHIRTS, T-SHIRTS, JERSEYS, SWEATERS, CARDIGANS, TANK TOPS, HALTER TOPS, PANTS, SWEAT PANTS, SHORTS, CAMISOLES; LADIES' AND MEN'S LINGERIE; LADIES' AND MEN'S UNDERWEAR NAMELY, BRIEFS, BOXER SHORTS, BOY SHORTS, THONGS, G-STRINGS, BRAS, TEDDIES, MERRY WIDOWS, BODY STOCKINGS, CORSETS, SLIPS, GARTER BELTS, SARONGS; SLEEPWEAR, NAMELY, BATHROBES, NIGHT SHIRTS, PAJAMAS, SLEEPING GOWNS; KIMONOS; COATS, JACKETS, VESTS, DRESSES, SKIRTS, BLOUSES, ROMPERS, SWIMWEAR; RAINWEAR, NAMELY, RAINCOATS, RAIN BONNETS, RAIN BOOTS, AND RAIN CAPES; TIES, ASCOTS, BELTS, SCARVES; FOOTWEAR, NAMELY, SHOES, BOOTS, SOCKS, TIGHTS AND STOCKINGS; HEADGEAR, NAMELY, HATS, CAPS AND BEANIES; APRONS; MASQUERADE COSTUMES (U.S. CLS. 22 AND 39).

CLASS 28—TOYS AND SPORTING GOODS

FOR GAMES, TOYS AND PLAYTHINGS, NAMELY, JUGGLING BALLS, JUGGLING PLATES, JUGGLING PINS, DIABOLOS, FLOWER STICKS, JUGGLING STICKS, JUGGLING SCARVES, JUGGLING RINGS, SKIPPING ROPES, JIGSAW PUZZLES, 3-D PUZZLES, MUSICAL RAINSTICKS, PLAYING CARDS, SPIN TOYS, TOY MOBILES, RETURN TOPS, DOLLS AND ACCESSORIES THEREFOR, MECHANICAL ACTION TOYS, SOAP BUBBLES, KITES, SPORTS BALLS, PLAYGROUND BALLS, RUBBER ACTION BOUNCING BALLS, BEACH BALLS; CHRISTMAS TREE DECORATIONS; FACE MASKS AND COSTUME MASKS; PUPPETS; CLOWN NOSES (U.S. CLS. 22, 23, 38 AND 50).
ROBIN CHOSID, EXAMINING ATTORNEY

SN 85-418,148. POLITICO LLC, ARLINGTON, VA. FILED 9-8-2011.

EL POLITICO

THE MARK CONSISTS OF STANDARD CHARACTERS WITHOUT CLAIM TO ANY PARTICULAR FONT, STYLE, SIZE, OR COLOR.

OWNER OF U.S. REG. NOS. 3,665,798, 4,013,952 AND OTHERS.

THE ENGLISH TRANSLATION OF "EL POLITICO" IN THE MARK IS "THE POLITICO".

CLASS 16—PAPER GOODS AND PRINTED MATTER

FOR NEWSPAPER REPORTING ON THE ACTIVITIES OF THE LEGISLATIVE AND EXECUTIVE BRANCHES OF THE FEDERAL GOVERNMENT, OFFICIALS AND EMPLOYEES OF THE EXECUTIVE AND LEGISLATIVE BRANCHES OF THE FEDERAL GOVERNMENT, MEMBERS OF CONGRESS AND THEIR CAMPAIGNS, AND OTHER MATTERS OF INTEREST TO PEOPLE WHO WORK FOR OR WITH THE FEDERAL GOVERNMENT (U.S. CLS. 2, 5, 22, 23, 29, 37, 38 AND 50).

CLASS 41—EDUCATION AND ENTERTAINMENT

FOR PROVIDING NEWS AND INFORMATION VIA THE INTERNET IN THE NATURE OF CURRENT EVENT REPORTING ABOUT THE ACTIVITIES OF THE LEGISLATIVE AND EXECUTIVE BRANCHES OF THE FEDERAL GOVERNMENT, OFFICIALS AND EMPLOYEES OF THE EXECUTIVE AND LEGISLATIVE BRANCHES OF THE FEDERAL GOVERNMENT, MEMBERS OF CONGRESS AND THEIR CAMPAIGNS, AND OTHER MATTERS OF INTEREST TO PEOPLE WHO WORK FOR OR WITH THE FEDERAL GOVERNMENT (U.S. CLS. 100, 101 AND 107).

CAROLINE WOOD, EXAMINING ATTORNEY

SN 85-418,397. MÜNCH MOTORRAD TECHNIK (MMT) GMBH, WÜRZBURG, FED REP GERMANY, FILED 9-9-2011.

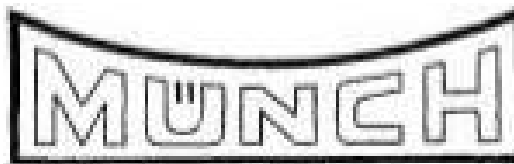

OWNER OF FED REP GERMANY REG. NO. 919298, DATED 6-10-1974, RENEWED AS REG. NO. 919298, DATED 1-19-2004, EXPIRES 1-31-2014.

OWNER OF U.S. REG. NO. 2,998,482.

THE MARK CONSISTS OF THE WORD "MÜNCH" IN A RECTANGLE WHOSE TOP SIDE IS CONCAVE, WITH THE LETTERS OF THE WORD "MÜNCH" FOLLOWING THE CURVATURE OF THE CONCAVE TOP SIDE.

CLASS 7—MACHINERY

FOR PARTS FOR TWO-WHEELED MOTOR VEHICLES AND MOTORCYCLES, NAMELY, OIL COOLERS IN THE NATURE OF VEHICLE ENGINE PARTS (U.S. CLS. 13, 19, 21, 23, 31, 34 AND 35).

CLASS 9—ELECTRICAL AND SCIENTIFIC APPARATUS

FOR BATTERIES FOR VEHICLES (U.S. CLS. 21, 23, 26, 36 AND 38).

CLASS 11—ENVIRONMENTAL CONTROL APPARATUS

FOR HEADLAMPS, NAMELY, AUTOMOTIVE HEADLAMPS, OUTDOOR PORTABLE LIGHTING PRODUCTS NAMELY HEADLAMPS (U.S. CLS. 13, 21, 23, 31 AND 34).

CLASS 12—VEHICLES

FOR TWO-WHEELED MOTOR VEHICLES, MOTORCYCLES AND PARTS FOR THESE GOODS, NAMELY VEHICLE ROLL BARS, LUGGAGE CARRIERS FOR VEHICLES, BENCHES FOR VEHICLES IN THE NATURE OF RETRACTABLE TAILGATE BENCHES, TYRES, BRAKES FOR VEHICLES, MOTORCYCLE DRIVE CHAINS AND DRIVE SHAFTS FOR LAND VEHICLES, HANDLEBARS (U.S. CLS. 19, 21, 23, 31, 35 AND 44).
KATHERINE E. HALMEN, EXAMINING ATTORNEY

SN 85-419,214. OMBU INC., BERKELEY, CA. FILED 9-9-2011.

OMBU

THE MARK CONSISTS OF STANDARD CHARACTERS WITHOUT CLAIM TO ANY PARTICULAR FONT, STYLE, SIZE, OR COLOR.

CLASS 9—ELECTRICAL AND SCIENTIFIC APPARATUS

FOR COMPUTER APPLICATIONS, NAMELY, COMPUTER APPLICATION SOFTWARE FOR EXCHANGING, DISTRIBUTING, PUSHING, COLLECTING, MANAGING, TRANSMITTING OR OTHERWISE SENDING DATA, PERSONAL INFORMATION, GENERAL INTEREST INFORMATION, MESSAGES, DIGITAL CONTENT, MEDIA CONTENT, SOFTWARE APPLICATIONS, CALENDAR EVENTS, SOCIAL MEDIA INFORMATION, COUPONS, AND MARKETING AND PROMOTIONAL INFORMATION TO, BETWEEN AND AMONG COMPUTING, ELECTRONIC AND MOBILE DEVICES; COMPUTER SOFTWARE PLATFORMS, APPLICATION PROGRAMMING INTERFACE (API) SOFTWARE, AND SOFTWARE DEVELOPMENT KITS (SDKS) FOR USE IN BUILDING SOFTWARE APPLICATIONS (U.S. CLS. 21, 23, 26, 36 AND 38).

CLASS 42—SCIENTIFIC AND COMPUTER SERVICES

FOR SOFTWARE AS A SERVICE (SAAS) SERVICES FEATURING SOFTWARE FOR EXCHANGING, DISTRIBUTING, PUSHING, COLLECTING, MANAGING, TRANSMITTING OR OTHERWISE SENDING DATA, PERSONAL INFORMATION, GENERAL INTEREST INFORMATION, MESSAGES, DIGITAL CONTENT, MEDIA CONTENT, SOFTWARE APPLICATIONS, CALENDAR EVENTS, SOCIAL MEDIA INFORMATION, COUPONS, AND MARKETING AND PROMOTIONAL INFORMATION TO, BETWEEN AND AMONG COMPUTING, ELECTRONIC AND MOBILE DEVICES; APPLICATION SERVICE PROVIDER (ASP) FEATURING APPLICATION PROGRAMMING INTERFACE (API) AND SOFTWARE DEVELOPMENT KITS (SDKS) SOFTWARE FOR USE IN BUILDING SOFTWARE APPLICATIONS; PROVIDING AN INTERACTIVE WEBSITE THAT ENABLES OTHERS TO MANAGE THEIR PERSONAL DIGITAL IDENTITY, NAMELY, PROVIDING AN INTERACTIVE WEBSITE FEATURING TECHNOLOGY THAT ALLOWS USERS TO SEARCH, EXCHANGE, DISTRIBUTE, COLLECT, MANAGE, TRANSMIT OR OTHERWISE SEND DATA, PERSONAL INFORMATION, GENERAL INTEREST INFORMATION, MESSAGES, DIGITAL CONTENT, MEDIA CONTENT, SOFTWARE APPLICATIONS, CALENDAR EVENTS, SOCIAL MEDIA INFORMATION, COUPONS, MARKETING, AND PROMOTIONAL INFORMATION (U.S. CLS. 100 AND 101).

MICHELLE DUBOIS, EXAMINING ATTORNEY

SN 85-419,251. THE RANCH STEAKHOUSE AND SALOON, INC., ANAHEIM, CA. FILED 9-9-2011.

THE RANCH



THE MARK CONSISTS OF THE WORDS "THE RANCH" ABOVE A STYLIZED COW'S SKULL WITH HORNS.

CLASS 21—HOUSEWARES AND GLASS

FOR WINE GLASSES; MUGS; CORKSCREWS; COASTERS, NOT OF PAPER AND NOT BEING TABLE LINEN; BOTTLE STOPPERS SPECIALLY ADAPTED FOR USE WITH WINE BOTTLES (U.S. CLS. 2, 13, 23, 29, 30, 33, 40 AND 50).

CLASS 24—FABRICS

FOR TABLE LINEN, NAMELY, COASTERS (U.S. CLS. 42 AND 50).

CLASS 25—CLOTHING

FOR HATS AND SHIRTS (U.S. CLS. 22 AND 39).

CLASS 41—EDUCATION AND ENTERTAINMENT

FOR ENTERTAINMENT SERVICES IN THE NATURE OF LIVE MUSICAL PERFORMANCES; EDUCATION SERVICES, NAMELY, PROVIDING CLASSES AND INSTRUCTION IN THE FIELD OF FOOD AND WINE (U.S. CLS. 100, 101 AND 107).

CLASS 43—HOTEL AND RESTAURANT SERVICES

FOR RESTAURANT AND BAR SERVICES (U.S. CLS. 100 AND 101).

MARY BOAGNI, EXAMINING ATTORNEY

SN 85-419,400. SITV, INC., GLENDALE, CA. FILED 9-9-2011.



NO CLAIM IS MADE TO THE EXCLUSIVE RIGHT TO USE "HD", APART FROM THE MARK AS SHOWN.

THE MARK CONSISTS OF THE LETTERS "NU" SURROUNDED BY A PARALLELOGRAM, FOLLOWED BY THE LETTERS "VO" SURROUNDED BY A PARALLELOGRAM, FOLLOWED BY "HD" IN SMALLER LETTERS SURROUNDED BY A PARALLELOGRAM.

THE WORDING "NUVO" HAS NO MEANING IN A FOREIGN LANGUAGE.

CLASS 38—COMMUNICATION

FOR BROADCASTING PROGRAMS VIA A GLOBAL COMPUTER NETWORK; CABLE TELEVISION BROADCASTING; COMMUNICATION SERVICES, NAMELY, TRANSMISSION OF VOICE, AUDIO, VISUAL IMAGES AND DATA BY TELECOMMUNICATIONS NETWORKS, WIRELESS COMMUNICATION NETWORKS, THE INTERNET, INFORMATION SERVICES NETWORKS AND DATA NETWORKS; MOBILE MEDIA SERVICES IN THE NATURE OF ELECTRONIC TRANSMISSION OF ENTERTAINMENT MEDIA CONTENT; SATELLITE TELEVISION BROADCASTING; TELEVISION BROADCASTING; VIDEO TRANSMISSION OVER DIGITAL NETWORKS (U.S. CLS. 100, 101 AND 104).

CLASS 41—EDUCATION AND ENTERTAINMENT

FOR ENTERTAINMENT IN THE NATURE OF ONGOING TELEVISION PROGRAMS IN THE FIELD OF MUSIC, ENTERTAINMENT, NEWS, REALITY AND GENERAL INTEREST TOPICS; ENTERTAINMENT SERVICES, NAMELY, PROVIDING A WEB SITE FEATURING PHOTOGRAPHIC, AUDIO, VIDEO AND PROSE PRESENTATIONS FEATURING MUSIC, ENTERTAINMENT, NEWS, REALITY AND GENERAL INTEREST TOPICS; ENTERTAINMENT SERVICES, NAMELY, THE PROVISION OF CONTINUING PROGRAMS, SEGMENTS AND SHOWS FEATURING MUSIC, ENTERTAINMENT, NEWS, REALITY AND GENERAL INTEREST TOPICS DELIVERED BY CABLE AND SATELLITE TELEVISION, ONLINE AND WIRELESS NETWORKS; PROVIDING INFORMATION, NEWS AND COMMENTARY IN THE FIELD OF ENTERTAINMENT (U.S. CLS. 100, 101 AND 107).

MARGARET POWER, EXAMINING ATTORNEY

SN 85-419,401. SITV, INC., GLENDALE, CA. FILED 9-9-2011.

nuvo

THE MARK CONSISTS OF STANDARD CHARACTERS WITHOUT CLAIM TO ANY PARTICULAR FONT, STYLE, SIZE, OR COLOR.

THE WORDING "NUVO" HAS NO MEANING IN A FOREIGN LANGUAGE.

CLASS 38—COMMUNICATION

FOR BROADCASTING PROGRAMS VIA A GLOBAL COMPUTER NETWORK; CABLE TELEVISION BROADCASTING; COMMUNICATION SERVICES, NAMELY, TRANSMISSION OF VOICE, AUDIO, VISUAL IMAGES AND DATA BY TELECOMMUNICATIONS NETWORKS, WIRELESS COMMUNICATION NETWORKS, THE INTERNET, INFORMATION SERVICES NETWORKS AND DATA NETWORKS; MOBILE MEDIA SERVICES IN THE NATURE OF ELECTRONIC TRANSMISSION OF ENTERTAINMENT MEDIA CONTENT; SATELLITE TELEVISION BROADCASTING; TELEVISION BROADCASTING; VIDEO TRANSMISSION OVER DIGITAL NETWORKS (U.S. CLS. 100, 101 AND 104).

CLASS 41—EDUCATION AND ENTERTAINMENT

FOR ENTERTAINMENT IN THE NATURE OF ONGOING TELEVISION PROGRAMS IN THE FIELD OF MUSIC, ENTERTAINMENT, NEWS, REALITY AND GENERAL INTEREST TOPICS; ENTERTAINMENT SERVICES, NAMELY, PROVIDING A WEB SITE FEATURING PHOTOGRAPHIC, AUDIO, VIDEO AND PROSE PRESENTATIONS FEATURING MUSIC, ENTERTAINMENT, NEWS, REALITY AND GENERAL INTEREST TOPICS; ENTERTAINMENT SERVICES, NAMELY, THE PROVISION OF CONTINUING PROGRAMS, SEGMENTS AND SHOWS FEATURING MUSIC, ENTERTAINMENT, NEWS, REALITY AND GENERAL INTEREST TOPICS DELIVERED BY CABLE AND SATELLITE TELEVISION, ONLINE AND WIRELESS NETWORKS; PROVIDING INFORMATION, NEWS AND COMMENTARY IN THE FIELD OF ENTERTAINMENT (U.S. CLS. 100, 101 AND 107).

MARGARET POWER, EXAMINING ATTORNEY

SN 85-420,748. AMERICAN LABORATORY PRODUCTS COMPANY, LTD., SALEM, NH. FILED 9-12-2011.

ALPCO DIAGNOSTICS

THE MARK CONSISTS OF STANDARD CHARACTERS WITHOUT CLAIM TO ANY PARTICULAR FONT, STYLE, SIZE, OR COLOR.

NO CLAIM IS MADE TO THE EXCLUSIVE RIGHT TO USE "DIAGNOSTICS", APART FROM THE MARK AS SHOWN.

CLASS 1—CHEMICALS

FOR IMMUNOASSAY KITS COMPRISED OF ANTIGENS, ANTIBODIES, AND REAGENTS FOR SCIENTIFIC RESEARCH; IMMUNOASSAY KITS COMPRISED OF ANTIGENS AND REAGENTS FOR SCIENTIFIC RESEARCH; IMMUNOASSAY KITS COMPRISED OF ANTIBODIES AND REAGENTS FOR SCIENTIFIC RESEARCH; ASSAY KITS COMPRISED OF ANTIGENS, ANTIBODIES, AND REAGENTS FOR SCIENTIFIC RESEARCH; ASSAY KITS COMPRISED OF ANTIGENS AND REAGENTS FOR SCIENTIFIC RESEARCH; ASSAY KITS COMPRISED OF ANTIBODIES AND REAGENTS FOR SCIENTIFIC RESEARCH (U.S. CLS. 1, 5, 6, 10, 26 AND 46).

FIRST USE 8-0-1999; IN COMMERCE 8-0-1999.

CLASS 5—PHARMACEUTICALS

FOR IMMUNOASSAY KITS COMPRISED OF ANTIGENS, ANTIBODIES, AND REAGENTS FOR MEDICAL DIAGNOSTIC USE; IMMUNOASSAY KITS COMPRISED OF ANTIGENS AND REAGENTS FOR MEDICAL DIAGNOSTIC USE; IMMUNOASSAY KITS COMPRISED OF ANTIBODIES AND REAGENTS FOR MEDICAL DIAGNOSTIC USE; ASSAY KITS COMPRISED OF ANTIGENS, ANTIBODIES, AND REAGENTS FOR MEDICAL DIAGNOSTIC USE; ASSAY KITS COMPRISED OF ANTIGENS AND REAGENTS FOR MEDICAL DIAGNOSTIC USE; ASSAY KITS COMPRISED OF ANTIBODIES AND REAGENTS FOR MEDICAL DIAGNOSTIC USE (U.S. CLS. 6, 18, 44, 46, 51 AND 52).

FIRST USE 8-0-2007; IN COMMERCE 8-0-2007.

TASHIA BUNCH, EXAMINING ATTORNEY

SN 85-420,750. AMERICAN LABORATORY PRODUCTS COMPANY, LTD., SALEM, NH. FILED 9-12-2011.

ALPCO IMMUNOASSAYS

THE MARK CONSISTS OF STANDARD CHARACTERS WITHOUT CLAIM TO ANY PARTICULAR FONT, STYLE, SIZE, OR COLOR.

NO CLAIM IS MADE TO THE EXCLUSIVE RIGHT TO USE "IMMUNOASSAYS", APART FROM THE MARK AS SHOWN.

CLASS 1—CHEMICALS

FOR IMMUNOASSAY KITS COMPRISED OF ANTIGENS, ANTIBODIES, AND REAGENTS FOR SCIENTIFIC RESEARCH; IMMUNOASSAY KITS COMPRISED OF ANTIGENS AND REAGENTS FOR SCIENTIFIC RESEARCH; IMMUNOASSAY KITS COMPRISED OF ANTIBODIES AND REAGENTS FOR SCIENTIFIC RESEARCH; ASSAY KITS COMPRISED OF ANTIGENS, ANTIBODIES, AND REAGENTS FOR SCIENTIFIC RESEARCH; ASSAY KITS COMPRISED OF ANTIGENS AND REAGENTS FOR SCIENTIFIC RESEARCH; ASSAY KITS COMPRISED OF ANTIBODIES AND REAGENTS FOR SCIENTIFIC RESEARCH (U.S. CLS. 1, 5, 6, 10, 26 AND 46).

FIRST USE 8-0-2007; IN COMMERCE 8-0-2007.

CLASS 5—PHARMACEUTICALS

FOR IMMUNOASSAY KITS COMPRISED OF ANTIGENS, ANTIBODIES, AND REAGENTS FOR MEDICAL DIAGNOSTIC USE; IMMUNOASSAY KITS COMPRISED OF ANTIGENS AND REAGENTS FOR MEDICAL DIAGNOSTIC USE; IMMUNOASSAY KITS COMPRISED OF ANTIBODIES AND REAGENTS FOR MEDICAL DIAGNOSTIC USE; ASSAY KITS COMPRISED OF ANTIGENS, ANTIBODIES, AND REAGENTS FOR MEDICAL DIAGNOSTIC USE; ASSAY KITS COMPRISED OF ANTIGENS AND REAGENTS FOR MEDICAL DIAGNOSTIC USE; ASSAY KITS COMPRISED OF ANTIBODIES AND REAGENTS FOR MEDICAL DIAGNOSTIC USE (U.S. CLS. 6, 18, 44, 46, 51 AND 52).

FIRST USE 8-0-2007; IN COMMERCE 8-0-2007.

TASHIA BUNCH, EXAMINING ATTORNEY

SN 85-420,994. INTELICA COMMERCIAL REAL ESTATE COMPANY, ST. LOUIS, MO. FILED 9-13-2011.

INTELICA CRE

THE MARK CONSISTS OF STANDARD CHARACTERS WITHOUT CLAIM TO ANY PARTICULAR FONT, STYLE, SIZE, OR COLOR.

NO CLAIM IS MADE TO THE EXCLUSIVE RIGHT TO USE "CRE", APART FROM THE MARK AS SHOWN.

THE WORDING "INTELICA" HAS NO MEANING IN A FOREIGN LANGUAGE.

CLASS 36—INSURANCE AND FINANCIAL

FOR COMMERCIAL REAL ESTATE AGENCY SERVICES; REAL ESTATE MANAGEMENT SERVICES (U.S. CLS. 100, 101 AND 102).

CLASS 37—CONSTRUCTION AND REPAIR

FOR COMMERCIAL REAL ESTATE DEVELOPMENT (U.S. CLS. 100, 103 AND 106).

LINDA ESTRADA, EXAMINING ATTORNEY

SN 85-421,056. AMERICAN LABORATORY PRODUCTS COMPANY, LTD., SALEM, NH. FILED 9-13-2011.

ALPCO

THE MARK CONSISTS OF STANDARD CHARACTERS WITHOUT CLAIM TO ANY PARTICULAR FONT, STYLE, SIZE, OR COLOR.

CLASS 1—CHEMICALS

FOR IMMUNOASSAY KITS COMPRISED OF ANTIGENS, ANTIBODIES, AND REAGENTS FOR SCIENTIFIC RESEARCH; IMMUNOASSAY KITS COMPRISED OF ANTIGENS AND REAGENTS FOR SCIENTIFIC RESEARCH; IMMUNOASSAY KITS COMPRISED OF ANTIBODIES AND REAGENTS FOR SCIENTIFIC RESEARCH; ASSAY KITS COMPRISED OF ANTIGENS, ANTIBODIES, AND REAGENTS FOR SCIENTIFIC RESEARCH; ASSAY KITS COMPRISED OF ANTIGENS AND REAGENTS FOR SCIENTIFIC RESEARCH; ASSAY KITS COMPRISED OF ANTIBODIES AND REAGENTS FOR SCIENTIFIC RESEARCH; ASSAY KITS COMPRISED OF ANTIBODIES AND REAGENTS FOR SCIENTIFIC RESEARCH (U.S. CLS. 1, 5, 6, 10, 26 AND 46).

FIRST USE 8-0-1999; IN COMMERCE 8-0-1999.

CLASS 5—PHARMACEUTICALS

FOR IMMUNOASSAY KITS COMPRISED OF ANTIGENS, ANTIBODIES, AND REAGENTS FOR MEDICAL DIAGNOSTIC USE; IMMUNOASSAY KITS COMPRISED OF ANTIGENS AND REAGENTS FOR MEDICAL DIAGNOSTIC USE; IMMUNOASSAY KITS COMPRISED OF ANTIBODIES AND REAGENTS FOR MEDICAL DIAGNOSTIC USE; ASSAY KITS COMPRISED OF ANTIGENS, ANTIBODIES, AND REAGENTS FOR MEDICAL DIAGNOSTIC USE; ASSAY KITS COMPRISED OF ANTIGENS AND REAGENTS FOR MEDICAL DIAGNOSTIC USE; ASSAY KITS COMPRISED OF ANTIBODIES AND REAGENTS FOR MEDICAL DIAGNOSTIC USE (U.S. CLS. 6, 18, 44, 46, 51 AND 52).

FIRST USE 8-0-2007; IN COMMERCE 8-0-2007.

TASHIA BUNCH, EXAMINING ATTORNEY

SN 85-421,231. PEABODY ENERGY CORPORATION, ST. LOUIS, MO. FILED 9-13-2011.

The logo for Peabody Energy features the word "Peabody" in a large, bold, blue sans-serif font. Below it, the word "ENERGY" is written in a smaller, blue, all-caps sans-serif font. To the left of "ENERGY" are four vertical blue bars of varying heights, resembling a stylized bar chart or a logo element.

NO CLAIM IS MADE TO THE EXCLUSIVE RIGHT TO USE "ENERGY", APART FROM THE MARK AS SHOWN.

THE COLOR(S) BLUE IS/ARE CLAIMED AS A FEATURE OF THE MARK.

THE MARK CONSISTS OF THE WORDS "PEABODY ENERGY" IN BLUE WITH A LONG RECTANGLE HAVING A CURVED EDGE ON THE LEFT AND FOUR SUCCESSIVELY SMALLER RECTANGLES ON THE RIGHT HAND SIDE, ALL UNDER THE FIRST HALF OF THE TERM "PEABODY".

CLASS 4—LUBRICANTS AND FUELS

FOR COAL (U.S. CLS. 1, 6 AND 15).

FIRST USE 5-3-2011; IN COMMERCE 5-3-2011.

CLASS 35—ADVERTISING AND BUSINESS

FOR PROMOTING THE INTERESTS OF THE COAL INDUSTRY BY DISSEMINATING CONSUMER AND INDUSTRY INFORMATION ABOUT COAL AND OTHER ENERGY SOURCES (U.S. CLS. 100, 101 AND 102).

FIRST USE 5-3-2011; IN COMMERCE 5-3-2011.
COLLEEN KEARNEY, EXAMINING ATTORNEY

CLASS 41—EDUCATION AND ENTERTAINMENT

FOR EDUCATIONAL AND ENTERTAINMENT SERVICES, NAMELY, PROVIDING MOTIVATIONAL SPEAKING SERVICES IN THE FIELD OF PERSONAL IMPROVEMENT, COMMUNICATION SKILLS AND MARKETING STRATEGIES (U.S. CLS. 100, 101 AND 107).

TRACY CROSS, EXAMINING ATTORNEY

SN 85-421,453. EMBRIA HEALTH SCIENCES, L.L.C., ANKENY, IA. FILED 9-13-2011.

SN 85-422,172. JAGGED PEAK, INC., TAMPA, FL. FILED 9-14-2011.

ACTS LIKE A MULTIVITAMIN
FOR YOUR IMMUNE SYSTEM

THE MARK CONSISTS OF STANDARD CHARACTERS WITHOUT CLAIM TO ANY PARTICULAR FONT, STYLE, SIZE, OR COLOR.

CLASS 1—CHEMICALS

FOR RAW MATERIALS FOR HUMAN AND ANIMAL HEALTH, NAMELY, CHEMICALS FOR USE IN THE MANUFACTURE OF DIETARY AND NUTRITIONAL SUPPLEMENTS, FOODS STUFFS AND BEVERAGES (U.S. CLS. 1, 5, 6, 10, 26 AND 46).

CLASS 5—PHARMACEUTICALS

FOR DIETARY SUPPLEMENTS, FOOD SUPPLEMENTS AND NUTRITIONAL SUPPLEMENTS (U.S. CLS. 6, 18, 44, 46, 51 AND 52).

CLASS 32—LIGHT BEVERAGES

FOR PREPARATIONS FOR MAKING FRUIT DRINKS, SPORTS DRINKS OR ENERGY DRINKS (U.S. CLS. 45, 46 AND 48).

SUNG IN, EXAMINING ATTORNEY

SN 85-421,767. DBC, LLC, LEHI, UT. FILED 9-13-2011.

DREAM ATROPHY

THE MARK CONSISTS OF STANDARD CHARACTERS WITHOUT CLAIM TO ANY PARTICULAR FONT, STYLE, SIZE, OR COLOR.

CLASS 16—PAPER GOODS AND PRINTED MATTER

FOR PRINTED MATTER, NAMELY, INSTRUCTIONAL AND MOTIVATIONAL BOOKLETS AND BROCHURES IN THE FIELD OF PERSONAL IMPROVEMENT; MOTIVATIONAL PRINTS AND CARDS (U.S. CLS. 2, 5, 22, 23, 29, 37, 38 AND 50).



THE MARK CONSISTS OF THE WORDING "FLEXNET" UNDERNEATH THE IMAGE OF A THREE DIMENSIONAL BOX WITH THE OUTLINE OF A HUMAN HAND ON THE LEFT AND RIGHT SIDES OF THE BOX.

CLASS 35—ADVERTISING AND BUSINESS

FOR BUSINESS SERVICES, NAMELY, PROVIDING ORDER FULFILLMENT AND SUPPLY CHAIN DISTRIBUTION SERVICES THROUGH THE USE OF A NETWORK OF WAREHOUSES; LOGISTICS SERVICES, NAMELY, SUPPLY CHAIN LOGISTICS AND REVERSE LOGISTICS SERVICES (U.S. CLS. 100, 101 AND 102).

FIRST USE 9-11-2011; IN COMMERCE 9-11-2011.

CLASS 39—TRANSPORTATION AND STORAGE

FOR ADVISORY AND CONSULTATION SERVICES IN THE FIELD OF WAREHOUSE STORAGE AND PACKAGING ARTICLES FOR TRANSPORTATION; WAREHOUSE STORAGE OF GOODS AND PACKAGING ARTICLES FOR TRANSPORTATION; FREIGHT FORWARDING (U.S. CLS. 100 AND 105).

FIRST USE 9-11-2011; IN COMMERCE 9-11-2011.
DAVID C. REIHNER, EXAMINING ATTORNEY

SN 85-422,571. CAP LOG GROUP, LLC, DAVIS, CA. FILED 9-14-2011.

TRACE AND TRUST

THE MARK CONSISTS OF STANDARD CHARACTERS WITHOUT CLAIM TO ANY PARTICULAR FONT, STYLE, SIZE, OR COLOR.

NO CLAIM IS MADE TO THE EXCLUSIVE RIGHT TO USE "TRACE", APART FROM THE MARK AS SHOWN.

CLASS 9—ELECTRICAL AND SCIENTIFIC APPARATUS

FOR COMPUTER SOFTWARE FOR USE IN PROVIDING AND OBTAINING INFORMATION ABOUT THE SOURCE OF FOOD AND FOOD PRODUCTS (U.S. CLS. 21, 23, 26, 36 AND 38).

FIRST USE 11-20-2010; IN COMMERCE 11-20-2010.

CLASS 35—ADVERTISING AND BUSINESS

FOR PROVIDING CONSUMER INFORMATION ABOUT THE SOURCE OF FOOD AND FOOD PRODUCTS; PROMOTING THE GOODS AND SERVICES OF OTHERS BY PROVIDING A WEBSITE FEATURING INFORMATION REGARDING THE SOURCE OR ORIGIN OF FOOD AND FOOD PRODUCTS; PROMOTING THE FOOD PRODUCTS AND COMMERCIAL FOOD SERVICES OF OTHERS (U.S. CLS. 100, 101 AND 102).

FIRST USE 11-20-2010; IN COMMERCE 11-20-2010.

CLASS 42—SCIENTIFIC AND COMPUTER SERVICES

FOR APPLICATION SERVICE PROVIDER (ASP) FEATURING SOFTWARE FOR USE BY CONSUMERS TO OBTAIN DETAILED INFORMATION REGARDING THE SOURCE OR ORIGIN OF FOOD AND FOOD PRODUCTS; PROVIDING A WEBSITE FEATURING ONLINE NON-DOWNLOADABLE SOFTWARE THAT ENABLES USERS TO OBTAIN DETAILED INFORMATION REGARDING THE SOURCE OR ORIGIN OF FOOD AND FOOD PRODUCTS; PROVIDING AN ONLINE NON-DOWNLOADABLE INTERNET-BASED SYSTEM APPLICATION FEATURING TECHNOLOGY ENABLING USERS TO OBTAIN DETAILED INFORMATION REGARDING THE SOURCE OR ORIGIN OF FOOD AND FOOD PRODUCTS (U.S. CLS. 100 AND 101).

FIRST USE 11-20-2010; IN COMMERCE 11-20-2010.
SUNG IN, EXAMINING ATTORNEY

SN 85-422,855. HEUSER HEALTH & FITNESS CENTER LLC, LOUISVILLE, KY. FILED 9-14-2011.



NO CLAIM IS MADE TO THE EXCLUSIVE RIGHT TO USE "CLINIC", APART FROM THE MARK AS SHOWN.

THE MARK CONSISTS OF THE WORDS "THE HEUSER CLINIC" APPEARING IN AN ARCHED FORM OVER A DESIGN ELEMENT CONSISTING OF A STYLIZED STICK FIGURE REPRESENTING A PERSON, WHICH APPEARS TO BE STANDING UPON THE WORDS "THE SCIENCE OF FITNESS".

CLASS 41—EDUCATION AND ENTERTAINMENT

FOR PROVIDING ASSISTANCE, PERSONAL TRAINING AND PHYSICAL FITNESS CONSULTATION TO CORPORATE CLIENTS TO HELP THEIR EMPLOYEES MAKE PHYSICAL FITNESS, STRENGTH, CONDITIONING, AND EXERCISE ALTERATIONS IN THEIR DAILY LIVING; PROVIDING ASSISTANCE, PERSONAL TRAINING AND PHYSICAL FITNESS CONSULTATION TO INDIVIDUALS TO HELP THEM MAKE PHYSICAL FITNESS, STRENGTH, CONDITIONING, AND EXERCISE IMPROVEMENT IN THEIR DAILY LIVING (U.S. CLS. 100, 101 AND 107).

FIRST USE 9-30-2002; IN COMMERCE 9-30-2002.

CLASS 44—MEDICAL, BEAUTY AND AGRICULTURAL SERVICES

FOR PROVIDING A WEBSITE FEATURING INFORMATION ABOUT HEALTH, WELLNESS AND NUTRITION; PROVIDING HEALTHY LIFESTYLE AND NUTRITION SERVICES, NAMELY, PERSONAL ASSESSMENTS, PERSONALIZED ROUTINES, MAINTENANCE SCHEDULES, AND COUNSELING; PROVIDING INFORMATION ABOUT DIETARY SUPPLEMENTS AND NUTRITION (U.S. CLS. 100 AND 101).

FIRST USE 9-30-2002; IN COMMERCE 9-30-2002.
RAMONA ORTIGA, EXAMINING ATTORNEY

SN 85-423,009. PACIFIC INSTITUTE OF CULINARY ARTS INC., VANCOUVER, BC, CANADA, FILED 9-14-2011.



OWNER OF CANADA REG. NO. TMA483,766, DATED 10-8-1997, EXPIRES 10-8-2012.

OWNER OF U.S. REG. NO. 3,130,796.

NO CLAIM IS MADE TO THE EXCLUSIVE RIGHT TO USE "INSTITUTE OF CULINARY ARTS", APART FROM THE MARK AS SHOWN.

THE MARK CONSISTS OF THE WORDS "PACIFIC INSTITUTE" DISPLAYED ABOVE THE WORD "OF" WHICH IS DISPLAYED ABOVE "CULINARY ARTS".

CLASS 41—EDUCATION AND ENTERTAINMENT

FOR EDUCATIONAL SERVICES, NAMELY, CONDUCTING COURSES OF INSTRUCTION, SEMINARS AND DEMONSTRATIONS IN THE FIELD OF CULINARY ARTS AND THE MANAGEMENT AND OPERATION OF RESTAURANTS (U.S. CLS. 100, 101 AND 107).

CLASS 43—HOTEL AND RESTAURANT SERVICES

FOR PROVIDING ON-LINE INFORMATION RELATING TO FOOD, BEVERAGE, COOKING, BAKING AND RECIPES (U.S. CLS. 100 AND 101).

REGINA DRUMMOND, EXAMINING ATTORNEY

SN 85-423,463. PACIFIC IMMUNOLOGY, DBA PACIFIC IMMUNOLOGY CORP., RAMONA, CA. FILED 9-15-2011.

PACIFIC IMMUNOLOGY

THE MARK CONSISTS OF STANDARD CHARACTERS WITHOUT CLAIM TO ANY PARTICULAR FONT, STYLE, SIZE, OR COLOR.

NO CLAIM IS MADE TO THE EXCLUSIVE RIGHT TO USE "IMMUNOLOGY", APART FROM THE MARK AS SHOWN.

CLASS 1—CHEMICALS

FOR ADJUVANTS FOR USE IN THE MANUFACTURE OF ANTIBODIES; BIOCHEMICALS, NAMELY, POLYCLONAL AND MONOCLONAL ANTIBODIES FOR IN VITRO SCIENTIFIC RESEARCH (U.S. CLS. 1, 5, 6, 10, 26 AND 46).

FIRST USE 6-1-2003; IN COMMERCE 6-1-2003.

CLASS 40—MATERIAL TREATMENT

FOR BIOMANUFACTURING FOR OTHERS, NAMELY, MANUFACTURING OF ANTIBODIES USING BIOLOGICAL ORGANISMS IN THE MANUFACTURING PROCESS; BIOMANUFACTURING SERVICES FOR OTHERS, NAMELY, MANUFACTURING ANTIBODIES TO THE ORDER AND SPECIFICATION OF OTHERS; MANUFACTURE OF PEPTIDES, ADJUVANTS AND IMMUNOASSAYS TO ORDER AND/OR SPECIFICATION OF OTHERS (U.S. CLS. 100, 103 AND 106).

FIRST USE 6-1-2003; IN COMMERCE 6-1-2003.

CLASS 42—SCIENTIFIC AND COMPUTER SERVICES

FOR BIOCHEMICAL LABORATORY SERVICES, NAMELY, ISOLATING, PURIFYING AND TESTING ANTIBODIES (U.S. CLS. 100 AND 101).

FIRST USE 6-1-2003; IN COMMERCE 6-1-2003.

MARK SPARACINO, EXAMINING ATTORNEY

SN 85-423,788. ICELOUNGE MEDIA, INC., NEW YORK, NY. FILED 9-15-2011.

Last Try

THE MARK CONSISTS OF STANDARD CHARACTERS WITHOUT CLAIM TO ANY PARTICULAR FONT, STYLE, SIZE, OR COLOR.

CLASS 35—ADVERTISING AND BUSINESS

FOR ADVERTISING, DISTRIBUTION OF ADVERTISING MATERIALS, AND PROMOTIONAL SERVICES, NAMELY, PROMOTING THE GOODS AND SERVICES OF OTHERS RELATING TO EXTREME SPORTS, INCLUDING SKATING AND SKATEBOARDING, AND URBAN YOUTH CULTURE, THROUGH ONLINE COMMUNITIES AND SHARING OF MULTIMEDIA, DIGITAL VIDEO, DIGITAL AUDIO, AND USER-GENERATED CONTENT VIA THE INTERNET, MOBILE PLATFORMS AND OTHER COMMUNICATIONS NETWORKS; PROVIDING A WEBSITE WHERE ADVERTISERS, MARKETERS, AND CONTENT PROVIDERS CAN REACH, ENGAGE, AND INTERACT WITH ONLINE USERS FOR THE PURPOSES OF PROMOTION OR ADVERTISING (U.S. CLS. 100, 101 AND 102).

FIRST USE 1-7-2011; IN COMMERCE 1-7-2011.

CLASS 38—COMMUNICATION

FOR AUDIO AND VIDEO BROADCASTING AND WEBCASTING SERVICES OVER THE INTERNET, MOBILE PLATFORMS OR OTHER COMMUNICATIONS NETWORKS, IN THE FIELDS OF EXTREME SPORTS, INCLUDING SKATING AND SKATEBOARDING, AND URBAN YOUTH CULTURE; TRANSMISSION OF DATA AND CONTENT VIA THE INTERNET, MOBILE PLATFORMS AND OTHER COMMUNICATIONS NETWORKS, NAMELY, ELECTRONICALLY TRANSMITTING INFORMATION, AUDIO, AND VIDEO CLIPS, IN THE FIELDS OF EXTREME SPORTS, INCLUDING SKATING AND SKATEBOARDING, AND URBAN YOUTH CULTURE; PROVIDING ON-LINE FORUMS AND ON-LINE CHAT ROOMS FOR THE TRANSMISSION OF MESSAGES, COMMENTS, MULTIMEDIA CONTENT, VIDEOS, MOVIES, PICTURES, IMAGES, TEXT, PHOTOS, USER-GENERATED CONTENT, AUDIO CONTENT, AND INFORMATION VIA THE INTERNET, MOBILE PLATFORMS AND OTHER COMMUNICATION NETWORKS, IN THE FIELDS OF EXTREME SPORTS, INCLUDING SKATING AND SKATEBOARDING, AND URBAN YOUTH CULTURE; PROVIDING ON-LINE COMMUNITY FORUMS FOR USERS TO POST, SEARCH, WATCH, SHARE, CRITIQUE, RATE, AND COMMENT ON, VIDEOS AND OTHER MULTIMEDIA CONTENT VIA THE INTERNET, MOBILE PLATFORMS AND OTHER COMMUNICATIONS NETWORK, IN THE FIELDS OF EXTREME SPORTS, INCLUDING SKATING AND SKATEBOARDING, AND URBAN YOUTH CULTURE (U.S. CLS. 100, 101 AND 104).

FIRST USE 1-7-2011; IN COMMERCE 1-7-2011.

CLASS 45—PERSONAL AND LEGAL SERVICES

FOR INTERNET AND MOBILE PLATFORMS BASED ON-LINE SOCIAL NETWORKING SERVICES FOR COMMUNITIES OF EXTREME SPORTS ENTHUSIASTS, INCLUDING SKATERS AND SKATEBOARDERS, AND URBAN YOUTH (U.S. CLS. 100 AND 101).

FIRST USE 1-7-2011; IN COMMERCE 1-7-2011.

ROBERT STRUCK, EXAMINING ATTORNEY

SN 85-423,990. UNITED LACROSSE LLC, LITTLE SILVER, NJ. FILED 9-15-2011.



THE MARK CONSISTS OF THE STYLIZED LETTER "U" WITH A STYLIZED LACROSSE STICK AND BALL WITHIN SAID LETTER.

CLASS 25—CLOTHING

FOR HATS; JACKETS; SHORTS; SOCKS; SPORTS JERSEYS; T-SHIRTS (U.S. CLS. 22 AND 39).
FIRST USE 9-12-2010; IN COMMERCE 9-12-2010.

CLASS 41—EDUCATION AND ENTERTAINMENT

FOR EDUCATIONAL SERVICES, NAMELY, CONDUCTING CLASSES IN THE FIELDS OF LACROSSE AND DISTRIBUTION OF TRAINING MATERIALS IN CONNECTION THEREWITH; OPERATION OF SPORTS CAMPS; ORGANIZING, ARRANGING, AND CONDUCTING LACROSSE EVENTS; TRAINING SERVICES IN THE FIELD OF LACROSSE (U.S. CLS. 100, 101 AND 107).
FIRST USE 9-12-2010; IN COMMERCE 9-12-2010.
DOMINICK J. SALEMI, EXAMINING ATTORNEY

SN 85-424,489. TNG WORLDWIDE, INC., FARMINGTON HILLS, MI. FILED 9-16-2011.

HAIR CARE SIMPLIFIED

THE MARK CONSISTS OF STANDARD CHARACTERS WITHOUT CLAIM TO ANY PARTICULAR FONT, STYLE, SIZE, OR COLOR.

NO CLAIM IS MADE TO THE EXCLUSIVE RIGHT TO USE "HAIR CARE", APART FROM THE MARK AS SHOWN.

CLASS 3—COSMETICS AND CLEANING PREPARATIONS

FOR HAIR CARE PREPARATIONS; NON-MEDICATED LEAVE-IN TREATMENT FOR HAIR; CONDITIONERS; HAIR CARE PREPARATIONS; HAIR CONDITIONERS; HAIR MASKS; HAIR SPRAY; HAIR SPRAYS; HAIRSPRAY; SHAMPOO-CONDITIONERS; SHAMPOOS (U.S. CLS. 1, 4, 6, 50, 51 AND 52).

CLASS 35—ADVERTISING AND BUSINESS

FOR RETAIL STORE, MAIL ORDER CATALOG, AND ONLINE ORDERING SERVICES FEATURING BEAUTY PRODUCTS (U.S. CLS. 100, 101 AND 102).
FIRST USE 10-1-2010; IN COMMERCE 10-1-2010.
ANDREW LEASER, EXAMINING ATTORNEY

SN 85-424,775. TOM O'GRADY, MERCER ISLAND, WA. AND MOLLY O'GRADY, MERCER ISLAND, WA. FILED 9-16-2011.

Teeing Off From the Bow

THE MARK CONSISTS OF STANDARD CHARACTERS WITHOUT CLAIM TO ANY PARTICULAR FONT, STYLE, SIZE, OR COLOR.

CLASS 39—TRANSPORTATION AND STORAGE

FOR PROVIDING INFORMATION, NEWS AND COMMENTARY IN THE FIELD OF TRAVEL (U.S. CLS. 100 AND 105).

CLASS 41—EDUCATION AND ENTERTAINMENT

FOR PROVIDING INFORMATION, NEWS AND COMMENTARY IN THE FIELD OF RECREATION AND LEISURE ACTIVITIES (U.S. CLS. 100, 101 AND 107).
ANN E. SAPPENFIELD, EXAMINING ATTORNEY

SN 85-425,654. STEED HAMMOND PAUL INC., DBA SHP LEADING DESIGN, CINCINNATI, OH. FILED 9-19-2011.



THE MARK CONSISTS OF STANDARD CHARACTERS WITHOUT CLAIM TO ANY PARTICULAR FONT, STYLE, SIZE, OR COLOR.

CLASS 9—ELECTRICAL AND SCIENTIFIC APPARATUS

FOR COMPUTER APPLICATION SOFTWARE FOR MOBILE PHONES, NAMELY, A FLASHCARD STUDY APPLICATION THAT ASSISTS INDIVIDUALS WHO ARE STUDYING FOR A CERTIFICATION EXAM IN THE FIELD OF ENVIRONMENTAL DESIGN, CONSTRUCTION, AND OPERATION OF BUILDINGS AND REAL ESTATE AND THE MAINTENANCE THEREOF; DOWNLOADABLE COMPUTER APPLICATION SOFTWARE FOR MOBILE PHONES, NAMELY, A FLASHCARD STUDY APPLICATION THAT ASSISTS INDIVIDUALS WHO ARE STUDYING FOR A CERTIFICATION EXAM IN THE FIELD OF ENVIRONMENTAL DESIGN, CONSTRUCTION, AND OPERATION OF BUILDINGS AND REAL ESTATE AND THE MAINTENANCE (U.S. CLS. 21, 23, 26, 36 AND 38).
FIRST USE 7-7-2009; IN COMMERCE 7-7-2009.

CLASS 35—ADVERTISING AND BUSINESS

FOR BUSINESS SERVICES, NAMELY, FACILITIES MANAGEMENT OF TECHNICAL OPERATIONS; WRITING OF GRANT PROPOSALS FOR EDUCATIONAL INSTITUTIONS, NON-PROFIT ORGANIZATIONS, AND FOR PRIVATE DEVELOPMENT AND RESEARCH ORGANIZATIONS; ENERGY AUDITING; CONSULTATION IN THE FIELD OF ENERGY EFFICIENCY (U.S. CLS. 100, 101 AND 102).

FIRST USE 3-0-2008; IN COMMERCE 3-0-2008.

CLASS 37—CONSTRUCTION AND REPAIR

FOR BUILDING CONSTRUCTION SERVICES, INCLUDING BUILDING CONSTRUCTION SUPERVISION, CONSULTATION AND PLANNING SERVICES (U.S. CLS. 100, 103 AND 106).

FIRST USE 3-0-2008; IN COMMERCE 3-0-2008.

CLASS 42—SCIENTIFIC AND COMPUTER SERVICES

FOR ENGINEERING SERVICES FOR FACILITY MANAGEMENT; ARCHITECTURAL AND ENGINEERING SERVICES, INCLUDING ARCHITECTURAL DESIGN, ARCHITECTURAL DESIGN CONSULTING SERVICES, SUSTAINABLE BUILDING DESIGN AND SUSTAINABLE BUILDING DESIGN CONSULTATION, RESEARCH BASED ARCHITECTURAL DESIGN SOLUTIONS FOR THE BUILT INDUSTRY, AND COMPUTER MODELING SERVICES, NAMELY, COMPUTER SIMULATION OF BUILDINGS FROM COMPUTER PROGRAMS FOR OTHERS; INTERIOR DESIGN SERVICES (U.S. CLS. 100 AND 101).

FIRST USE 3-0-2008; IN COMMERCE 3-0-2008.

HAI-LY LAM, EXAMINING ATTORNEY

SN 85-426,177. CQUOTIENT, INC., CAMBRIDGE, MA. FILED 9-19-2011.

SHOPPING GENOME

THE MARK CONSISTS OF STANDARD CHARACTERS WITHOUT CLAIM TO ANY PARTICULAR FONT, STYLE, SIZE, OR COLOR.

NO CLAIM IS MADE TO THE EXCLUSIVE RIGHT TO USE "SHOPPING", APART FROM THE MARK AS SHOWN.

CLASS 9—ELECTRICAL AND SCIENTIFIC APPARATUS

FOR COMPUTER SOFTWARE FOR USE IN ANALYZING BUSINESS AND RETAIL MARKET DATA IN THE FIELD OF BUSINESS AND RETAIL MARKET ANALYTICS (U.S. CLS. 21, 23, 26, 36 AND 38).

CLASS 35—ADVERTISING AND BUSINESS

FOR CONSUMER STRATEGY BUSINESS CONSULTING IN THE FIELDS OF MARKETING, SALES, OPERATION, AND PRODUCT DESIGN PARTICULARLY SPECIALIZING IN THE USE OF ANALYTIC MODELS FOR THE UNDERSTANDING AND PREDICTING OF CONSUMER, BUSINESS, AND RETAIL MARKET TRENDS AND ACTIONS (U.S. CLS. 100, 101 AND 102).

CLASS 42—SCIENTIFIC AND COMPUTER SERVICES

FOR SOFTWARE AS A SERVICE (SAAS) SERVICES FEATURING SOFTWARE FOR USE IN ANALYZING BUSINESS AND RETAIL MARKET DATA IN THE FIELD OF BUSINESS AND RETAIL MARKET ANALYTICS (U.S. CLS. 100 AND 101).

CURTIS FRENCH, EXAMINING ATTORNEY

SN 85-426,181. CQUOTIENT, INC., CAMBRIDGE, MA. FILED 9-19-2011.

SHOPPER GENOME

THE MARK CONSISTS OF STANDARD CHARACTERS WITHOUT CLAIM TO ANY PARTICULAR FONT, STYLE, SIZE, OR COLOR.

NO CLAIM IS MADE TO THE EXCLUSIVE RIGHT TO USE "SHOPPER", APART FROM THE MARK AS SHOWN.

CLASS 9—ELECTRICAL AND SCIENTIFIC APPARATUS

FOR COMPUTER SOFTWARE FOR USE IN ANALYZING BUSINESS AND RETAIL MARKET DATA IN THE FIELD OF BUSINESS AND RETAIL MARKET ANALYTICS (U.S. CLS. 21, 23, 26, 36 AND 38).

CLASS 35—ADVERTISING AND BUSINESS

FOR CONSUMER STRATEGY BUSINESS CONSULTING IN THE FIELDS OF MARKETING, SALES, OPERATION, AND PRODUCT DESIGN PARTICULARLY SPECIALIZING IN THE USE OF ANALYTIC MODELS FOR THE UNDERSTANDING AND PREDICTING OF CONSUMER, BUSINESS, AND RETAIL MARKET TRENDS AND ACTIONS (U.S. CLS. 100, 101 AND 102).

CLASS 42—SCIENTIFIC AND COMPUTER SERVICES

FOR SOFTWARE AS A SERVICE (SAAS) SERVICES FEATURING SOFTWARE FOR USE IN ANALYZING BUSINESS AND RETAIL MARKET DATA IN THE FIELD OF BUSINESS AND RETAIL MARKET ANALYTICS (U.S. CLS. 100 AND 101).

CURTIS FRENCH, EXAMINING ATTORNEY

SN 85-426,224. MONAVIE LLC, SOUTH JORDAN, UT. FILED 9-19-2011.

COMMUNITY COMMERCE

THE MARK CONSISTS OF STANDARD CHARACTERS WITHOUT CLAIM TO ANY PARTICULAR FONT, STYLE, SIZE, OR COLOR.

NO CLAIM IS MADE TO THE EXCLUSIVE RIGHT TO USE "COMMERCE", APART FROM THE MARK AS SHOWN.

CLASS 41—EDUCATION AND ENTERTAINMENT

FOR EDUCATION SERVICES, NAMELY, PROVIDING SEMINARS IN THE FIELD OF NUTRITION AND WELLNESS; EDUCATIONAL SERVICES, NAMELY, CONDUCTING INFORMAL ON-LINE PROGRAMS IN THE FIELDS OF NUTRITION AND WELLNESS, AND PRINTABLE MATERIALS DISTRIBUTED THEREWITH; EDUCATIONAL SERVICES, NAMELY, CONDUCTING SEMINARS IN THE FIELDS OF NUTRITION AND WELLNESS AND DISTRIBUTION OF TRAINING MATERIALS IN CONNECTION THEREWITH; EDUCATIONAL SERVICES, NAMELY, PROVIDING ON-LINE SEMINARS IN THE FIELD OF NUTRITION AND WELLNESS; PROVIDING A WEB SITE THAT FEATURES INFORMAL INSTRUCTION ON NUTRITION AND WELLNESS (U.S. CLS. 100, 101 AND 107).

CLASS 44—MEDICAL, BEAUTY AND AGRICULTURAL SERVICES

FOR DIETARY AND NUTRITIONAL GUIDANCE; PROVIDING A WEB SITE FEATURING INFORMATION ON HEALTH AND NUTRITION; PROVIDING A WEBSITE FEATURING INFORMATION ABOUT HEALTH, WELLNESS AND NUTRITION; PROVIDING AN ON-LINE COMPUTER DATABASE FEATURING INFORMATION REGARDING HEALTH AND NUTRITION; PROVIDING ASSISTANCE, FITNESS EVALUATION AND CONSULTATION TO INDIVIDUALS TO HELP THEM MAKE HEALTH, WELLNESS AND NUTRITIONAL CHANGES IN THEIR DAILY LIVING TO IMPROVE HEALTH; PROVIDING INFORMATION ABOUT DIETARY SUPPLEMENTS AND NUTRITION (U.S. CLS. 100 AND 101).

DAWN HAN, EXAMINING ATTORNEY

SN 85-426,605. TAYLOR, ROBERT, MELBOURNE, FL. FILED 9-20-2011.

NOT A HEARING AID

THE MARK CONSISTS OF STANDARD CHARACTERS WITHOUT CLAIM TO ANY PARTICULAR FONT, STYLE, SIZE, OR COLOR.

CLASS 9—ELECTRICAL AND SCIENTIFIC APPARATUS

FOR SOUND AMPLIFIERS; ELECTRICAL HEARING APPARATUS, NAMELY, NON-MEDICAL PERSONAL SOUND AMPLIFICATION DEVICES; HANDHELD ELECTRONIC UNITS FOR ADJUSTING SOUND LEVELS IN HEARING AIDS; EARPHONES AND HEADPHONES (U.S. CLS. 21, 23, 26, 36 AND 38).

CLASS 10—MEDICAL APPARATUS

FOR ELECTRICAL APPARATUS, NAMELY, MEDICAL PERSONAL SOUND AMPLIFICATION DEVICES; ELECTRICAL APPARATUS, NAMELY, MEDICAL PERSONAL SOUND AMPLIFICATION DEVICES WORN ON THE BODY (U.S. CLS. 26, 39 AND 44).

LINDA E. BLOHM, EXAMINING ATTORNEY

SN 85-427,149. FRANKLINCovey, CO., SALT LAKE CITY, UT. FILED 9-20-2011.



OWNER OF U.S. REG. NOS. 2,531,872, 3,579,646 AND OTHERS.

THE COLOR(S) PURPLE AND GREY IS/ARE CLAIMED AS A FEATURE OF THE MARK.

THE MARK CONSISTS OF THE FOLLOWING THE WORDING "FRANKLINCovey" IN PURPLE TITLE CASE LETTERING WITH NO SPACE, BELOW WHICH APPEARS THE WORDING "EXCELERATORS" IN LOWER CASE, WITH THE TERM "EXCEL" IN PURPLE AND THE LETTERS "ERATORS" IN GREY, WITH THE RIGHT-LEANING LINE IN THE LETTER "X" TOPPED BY AN ARROW, ALSO IN PURPLE.

CLASS 9—ELECTRICAL AND SCIENTIFIC APPARATUS

FOR DOWNLOADABLE WEBINARS IN THE FIELD OF PROFESSIONAL AND PERSONAL PRODUCTIVITY, LEADERSHIP, MANAGEMENT, EDUCATION, SALES, COMMUNICATION, PROFESSIONAL AND PERSONAL ASSESSMENT DEVELOPMENT, MEASUREMENT AND ORGANIZATION THROUGH TIME MANAGEMENT AND COMMUNICATION; DOWNLOADABLE SOFTWARE IN THE NATURE OF A MOBILE APPLICATION FOR WIRELESS CONTENT DELIVERY AND MOBILE INFORMATION ACCESS FOR TASK DELEGATION, REPORTING, EVENT SCHEDULING, CALENDARING AND TIME MANAGEMENT ALL IN THE FIELD OF PERSONAL AND BUSINESS PRODUCTIVITY, LEADERSHIP, MANAGEMENT, AND PROFESSIONAL AND PERSONAL DEVELOPMENT; CDS AND DVDS FEATURING INFORMATION IN THE FIELD OF PROFESSIONAL AND PERSONAL PRODUCTIVITY, LEADERSHIP, MANAGEMENT, EDUCATION, SALES, ORGANIZATIONAL COMMUNICATION, PROFESSIONAL AND PERSONAL ASSESSMENT DEVELOPMENT, MEASUREMENT AND ORGANIZATION THROUGH TIME MANAGEMENT AND COMMUNICATION (U.S. CLS. 21, 23, 26, 36 AND 38).

CLASS 41—EDUCATION AND ENTERTAINMENT

FOR EDUCATION SERVICES, NAMELY, PROVIDING LIVE AND ON-LINE CLASSES, SEMINARS, WORKSHOPS IN THE FIELD OF PROFESSIONAL AND PERSONAL PRODUCTIVITY, LEADERSHIP, MANAGEMENT, EDUCATION, SALES, COMMUNICATION, PROFESSIONAL AND PERSONAL DEVELOPMENT, MEASUREMENT AND ORGANIZATION THROUGH TIME MANAGEMENT AND COMMUNICATION (U.S. CLS. 100, 101 AND 107).

EDWARD FENNESSY, EXAMINING ATTORNEY

SN 85-427,680. JOERNS LLC, STEVENS POINT, WI. FILED 9-20-2011.



THE MARK CONSISTS OF STANDARD CHARACTERS WITHOUT CLAIM TO ANY PARTICULAR FONT, STYLE, SIZE, OR COLOR.

OWNER OF U.S. REG. NOS. 3,599,428, 3,632,247 AND OTHERS.

CLASS 10—MEDICAL APPARATUS

FOR AIR INFLATED MATTRESSES AND MATTRESS PADS AND AIR INFLATING DEVICES NAMELY, INFLATION PUMPS AND ELECTRONIC CONTROL UNITS, SOLD TOGETHER AS A UNIT, FOR PREVENTION OF BED SORES; BODY SUPPORT PADS AND CUSHIONS FOR THERAPEUTIC MEDICAL USE; MATTRESSES FOR THERAPEUTIC PRESSURE RELIEF; MATTRESSES FOR MEDICAL USE (U.S. CLS. 26, 39 AND 44).

CLASS 20—FURNITURE AND ARTICLES NOT OTHERWISE CLASSIFIED

FOR HOSPITAL BEDS (U.S. CLS. 2, 13, 22, 25, 32 AND 50).

CLASS 44—MEDICAL, BEAUTY AND AGRICULTURAL SERVICES

FOR RENTAL OF BEDS MADE FOR MEDICAL PURPOSES, RENTAL OF MATTRESSES MADE FOR MEDICAL PURPOSES (U.S. CLS. 100 AND 101).
BRIAN CALLAGHAN, EXAMINING ATTORNEY

SN 85-427,817. YEARBOOK MACHINE LIMITED, LONDON, UNITED KINGDOM, FILED 9-21-2011.

YEARBOOK MACHINE

THE MARK CONSISTS OF STANDARD CHARACTERS WITHOUT CLAIM TO ANY PARTICULAR FONT, STYLE, SIZE, OR COLOR.

OWNER OF UNITED KINGDOM REG. NO. 2564448, DATED 11-17-2010, EXPIRES 11-17-2020.

NO CLAIM IS MADE TO THE EXCLUSIVE RIGHT TO USE "YEARBOOK", APART FROM THE MARK AS SHOWN.

CLASS 16—PAPER GOODS AND PRINTED MATTER

FOR (BASED ON 44(E)) BOOK COVERS; NEWSLETTERS IN THE FIELD OF CREATING YEARBOOKS, YEARBOOK LAYOUT, DESIGN, COMPILATION; PRINTED MATERIALS, NAMELY, WRITTEN ARTICLES IN THE FIELD OF CREATING YEARBOOKS, YEARBOOK LAYOUT, DESIGN, COMPILATION (U.S. CLS. 2, 5, 22, 23, 29, 37, 38 AND 50).

CLASS 38—COMMUNICATION

FOR (BASED ON 44(E)) COMMUNICATION SERVICES, NAMELY, ELECTRONIC TRANSMISSION OF DATA AND DOCUMENTS AMONG USERS OF COMPUTERS; COMMUNICATION SERVICES, NAMELY, PROVIDING ELECTRONIC TRANSMISSION OF INFORMATION STORED IN A DATABASE VIA INTERACTIVELY COMMUNICATING COMPUTER SYSTEMS; ELECTRONIC MAIL AND MESSAGING SERVICES; ELECTRONIC TRANSMISSION OF MAIL AND MESSAGES; PROVIDING ON-LINE CHAT ROOMS FOR SOCIAL NETWORKING; PROVIDING ON-LINE FORUMS FOR TRANSMISSION OF MESSAGES AMONG COMPUTER USERS; TRANSMISSION OF SOUND, VIDEO AND INFORMATION; VIDEO BROADCASTING SERVICES OVER THE INTERNET OR OTHER COMMUNICATIONS NETWORK FEATURING THE UPLOADED, POSTED AND TAGGED VIDEOS OF OTHERS (U.S. CLS. 100, 101 AND 104).

CLASS 41—EDUCATION AND ENTERTAINMENT

FOR (BASED ON 44(E)) BOOK PUBLISHING; PROVIDING ENTERTAINMENT INFORMATION SERVICES IN THE FORM OF ON-LINE COMPUTER DATABASES FEATURING INFORMATION REGARDING YEARBOOKS, SPECIFICALLY, THE CREATION, LAYOUT, DESIGN AND COMPILATION OF YEARBOOKS, FOR USE BY SECONDARY COLLEGIATE, SOCIAL AND COMMUNITY INTEREST GROUPS; PUBLISHING OF BOOKS, E-BOOKS, AUDIO BOOKS, MUSIC AND ILLUSTRATIONS (U.S. CLS. 100, 101 AND 107).

CLASS 42—SCIENTIFIC AND COMPUTER SERVICES

FOR (BASED ON USE IN COMMERCE) COMPUTER SERVICES, NAMELY, INTERACTIVE HOSTING SERVICES WHICH ALLOW THE USER TO PUBLISH AND SHARE THEIR OWN CONTENT AND IMAGES ON-LINE; COMPUTER SERVICES, NAMELY, PROVIDING AN INTERACTIVE WEB SITE FEATURING TECHNOLOGY THAT ALLOWS USERS TO CREATE THEIR OWN BOOKS; PEER-TO-BROWSER PHOTO SHARING SERVICES, NAMELY, PROVIDING A WEBSITE FEATURING TECHNOLOGY ENABLING USERS TO UPLOAD, VIEW, AND DOWNLOAD DIGITAL PHOTOS; PROVIDING A WEB-BASED SERVICE FEATURING TECHNOLOGY THAT ENABLES USERS TO MANAGE THE PRODUCTION AND PUBLICATION OF ELECTRONIC BOOKS (E-BOOKS) AND RELATED DIGITAL CONTENT AND OFFER THEM FOR SALE TO THE GENERAL PUBLIC (U.S. CLS. 100 AND 101).

FIRST USE 0-0-2009; IN COMMERCE 0-0-2009.
TRICIA SONNEBORN, EXAMINING ATTORNEY

SN 85-427,898. MEDAXIOM CARDIOLOGY, LLC, NEPTUNE BEACH, FL. FILED 9-21-2011.

**THINK TRANSFORMING
HEALTHCARE WITH INNOVATION
AND KNOWLEDGE SHARING**

THE MARK CONSISTS OF STANDARD CHARACTERS WITHOUT CLAIM TO ANY PARTICULAR FONT, STYLE, SIZE, OR COLOR.

CLASS 35—ADVERTISING AND BUSINESS

FOR BUSINESS CONSULTATION IN THE FIELD OF MEDICINE (U.S. CLS. 100, 101 AND 102).

FIRST USE 7-1-2011; IN COMMERCE 7-1-2011.

CLASS 44—MEDICAL, BEAUTY AND AGRICULTURAL SERVICES

FOR THINK TANK SERVICES IN THE NATURE OF CONSULTATION SERVICES IN THE FIELD OF MEDICINE (U.S. CLS. 100 AND 101).

FIRST USE 7-1-2011; IN COMMERCE 7-1-2011.
 NAPOLEON SHARMA, EXAMINING ATTORNEY

SN 85-428,567. CHATVIBES LTD., TEL AVIV, ISRAEL, FILED 9-21-2011.

CHATVIBES

THE MARK CONSISTS OF STANDARD CHARACTERS WITHOUT CLAIM TO ANY PARTICULAR FONT, STYLE, SIZE, OR COLOR.

CLASS 9—ELECTRICAL AND SCIENTIFIC APPARATUS

FOR DOWNLOADABLE COMPUTER SOFTWARE FOR USE IN TELECOMMUNICATIONS AND VOICE OVER INTERNET PROTOCOL (VOIP) APPLICATIONS, DATA TRANSMISSION AND INSTANT MESSAGING SERVICES PROVIDED BY MEANS OF SOCIAL MEDIA (U.S. CLS. 21, 23, 26, 36 AND 38).

FIRST USE 11-17-2010; IN COMMERCE 11-17-2010.

CLASS 42—SCIENTIFIC AND COMPUTER SERVICES

FOR COMPUTER SERVICES AND SOFTWARE DEVELOPMENT FOR OTHERS, NAMELY, DESIGN FOR OTHERS OF COMPUTER SOFTWARE AND HARDWARE FOR USE IN TELECOMMUNICATIONS AND VOICE OVER INTERNET PROTOCOL (VOIP) APPLICATIONS, DATA TRANSMISSION AND INSTANT MESSAGING SERVICES (U.S. CLS. 100 AND 101).

FIRST USE 11-17-2010; IN COMMERCE 11-17-2010.

JOHN WILKE, EXAMINING ATTORNEY

ONE TWO FREE

THE MARK CONSISTS OF STANDARD CHARACTERS WITHOUT CLAIM TO ANY PARTICULAR FONT, STYLE, SIZE, OR COLOR.

CLASS 7—MACHINERY

FOR HOUSEHOLD AND KITCHEN MACHINES AND EQUIPMENT, NAMELY, ELECTRIC KITCHEN MACHINES AND EQUIPMENT, NAMELY, DISHWASHERS; STRUCTURAL PARTS OF ALL AFOREMENTIONED GOODS (U.S. CLS. 13, 19, 21, 23, 31, 34 AND 35).

CLASS 11—ENVIRONMENTAL CONTROL APPARATUS

FOR HOUSEHOLD AND KITCHEN MACHINES AND EQUIPMENT, NAMELY, HEATING, STEAM PRODUCING, AND COOKING DEVICES, NAMELY, COOKING, BAKING, FRYING, GRILLING, TOASTING, THAWING, AND HOT-KEEPING APPARATUS, NAMELY, DOMESTIC COOKING OVENS, ELECTRIC AND GAS RANGES, COOKTOPS, WARMING DRAWERS SOLD AS PARTS OF OVENS, RANGES AND COOKTOPS, MICROWAVE APPLIANCES, NAMELY, MICROWAVE OVENS, ELECTRIC BEVERAGE MAKING MACHINES, NAMELY, ELECTRIC COFFEE MAKERS, ELECTRIC ESPRESSO MACHINES, TEMPERATURE CONTROLLED BEVERAGE DISPENSERS; COOLING DEVICES, NAMELY, REFRIGERATORS, FREEZERS, COMBINATION REFRIGERATOR-FREEZERS, DEEP FREEZERS, ICE MAKING MACHINES, ICE-CREAM MAKERS AND FREEZERS; VENTILATION DEVICES, NAMELY, VENTILATORS SOLD AS PARTS OF HOODS FOR RANGES, OVENS AND COOKTOPS, GREASE FILTER DEVICES SOLD AS PARTS OF HOODS FOR RANGES, OVENS AND COOKTOPS; EXTRACTOR DEVICES, NAMELY, EXTRACTOR HOODS; AIR CONDITIONING DEVICES AND DEVICES TO IMPROVE AIR QUALITY, NAMELY, AIR HUMIDIFIERS, PIPES BEING PARTS OF SANITARY FACILITIES; WARM WATER DEVICES, NAMELY, STORAGE WATER HEATERS AND CONTINUOUS FLOW WATER HEATERS; KITCHEN SINKS; HEAT PUMPS; STRUCTURAL PARTS OF ALL AFOREMENTIONED GOODS (U.S. CLS. 13, 21, 23, 31 AND 34).

CLASS 35—ADVERTISING AND BUSINESS

FOR RETAIL STORE SERVICES AND ONLINE STORE SERVICES IN THE FIELD OF HOME APPLIANCES (U.S. CLS. 100, 101 AND 102).

ELI HELLMAN, EXAMINING ATTORNEY

SN 85-429,151. BREYNER, CHAPONNAY, FRANCE, FILED 9-22-2011.

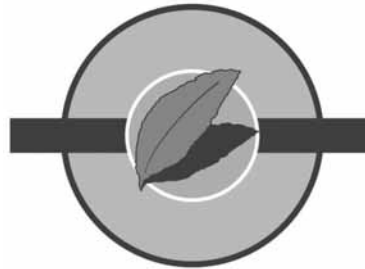

OWNER OF FRANCE REG. NO. 053385185, DATED 10-11-2005, EXPIRES 10-10-2015.

THE MARK CONSISTS OF TWO CONCENTRIC CIRCLES WITH A LEAF DESIGN INSIDE THE INNER CIRCLE. THERE IS A RECTANGULAR BAND CUTTING THROUGH THE MIDDLE OF THE CIRCLES.

CLASS 20—FURNITURE AND ARTICLES NOT OTHERWISE CLASSIFIED

FOR FURNITURE; MIRRORS, PICTURE FRAMES; BEDDING, NAMELY, BEDS, BED FRAMES, MATTRESSES, MATTRESS FOUNDATIONS, PILLOWS, AND BOLSTERS; WORKS OF ART MADE OF WOOD, CORK, REED, WICKER, CANE, HORN, BONE, IVORY, WHALEBONE, SHELL, AMBER, MOTHER-OF-PEARL AND MEERSCHAUM, IMITATIONS OF THE FOREGOING MATERIALS, OR OF PLASTIC; PACKAGING CONTAINERS OF PLASTIC (U.S. CLS. 2, 13, 22, 25, 32 AND 50).

CLASS 22—CORDAGE AND FIBERS

FOR ROPES NEITHER MADE OF RUBBER, NOR INTENDED AS STRINGS FOR RACKETS OR MUSICAL INSTRUMENTS, STRING, FISHING NETS, CAMOUFLAGE NETS, TENTS, TARPAULINS, SAILS; TEXTILE BAGS AND POUCHES FOR PACKAGING; PADDING AND STUFFING MATERIALS EXCEPT OF RUBBER OR PLASTIC; RAW FIBROUS TEXTILE MATERIALS; TEXTILE FIBERS AND PLASTIC FIBERS FOR TEXTILE USE (U.S. CLS. 1, 2, 7, 19, 22, 42 AND 50).

CLASS 24—FABRICS

FOR FABRICS FOR TEXTILE USE; ELASTIC WOVEN FABRICS; TEXTILE LABELS; LINGERIE FABRIC; HOUSEHOLD, BED AND TABLE LINEN EXCEPT FOR TABLE LINEN OF PAPER; BED AND PLASTIC TABLE COVERS AND TRAVELLING BLANKETS (U.S. CLS. 42 AND 50).

SHAUNIA CARLYLE, EXAMINING ATTORNEY

SN 85-429,254. KING'S RIB BUSTER, EDMOND, OK. FILED 9-22-2011.



NO CLAIM IS MADE TO THE EXCLUSIVE RIGHT TO USE "RIB", APART FROM THE MARK AS SHOWN.

THE MARK CONSISTS OF A CROWN WITH 5 POINTS. THE STYLIZED TEXT "KING'S" IS WRITTEN ON THE CROWN AND THE STYLIZED TEXT "RIB BUSTER" IS WRITTEN BELOW.

CLASS 29—MEATS AND PROCESSED FOODS

FOR FRUIT PRESERVES; ONION RINGS (U.S. CL. 46).

CLASS 30—STAPLE FOODS

FOR BARBECUE SAUCE; SPICE RUBS (U.S. CL. 46).
DAVID MURRAY, EXAMINING ATTORNEY

SN 85-429,289. DIAMOND WIPES, CHINO, CA. FILED 9-22-2011.

TRAVEL LITE

THE MARK CONSISTS OF STANDARD CHARACTERS WITHOUT CLAIM TO ANY PARTICULAR FONT, STYLE, SIZE, OR COLOR.

NO CLAIM IS MADE TO THE EXCLUSIVE RIGHT TO USE "TRAVEL", APART FROM THE MARK AS SHOWN.

CLASS 3—COSMETICS AND CLEANING PREPARATIONS

FOR AROMATIC BODY CARE PRODUCTS, NAMELY, BODY LOTION, SHOWER GEL, CUTICLE CREAM, SHAMPOO, CONDITIONER, NON-MEDICATED LIP BALM, SOAP, BODY POLISH, BODY AND FOOT SCRUB AND NON-MEDICATED FOOT CREAM; BABY WIPES; BATH AND SHOWER GELS AND SALTS NOT FOR MEDICAL PURPOSES; BATH GEL; BATH GELS; BATH SOAPS IN LIQUID, SOLID OR GEL FORM; BEAUTY GELS; COSMETIC MASSAGE CREAMS; DISPOSABLE WIPES IMPREGNATED WITH CLEANING CHEMICALS OR COMPOUNDS FOR INDUSTRIAL AND COMMERCIAL USE; DISPOSABLE WIPES IMPREGNATED WITH CLEANSING CHEMICALS OR COMPOUNDS FOR PERSONAL HYGIENE; DISPOSABLE WIPES IMPREGNATED WITH CLEANSING COMPOUNDS FOR USE ON RAILINGS, PANELS, COUNTERTOPS, DESKTOPS, AND TOILET SEATS; ESSENTIAL OILS; ESSENTIAL OILS FOR AROMATHERAPY USE; ESSENTIAL OILS FOR PERSONAL USE; LIQUID BATH SOAPS; LIQUID SOAPS FOR HANDS, FACE AND BODY; MASSAGE CREAMS; MASSAGE GELS OTHER THAN FOR MEDICAL PURPOSES; MASSAGE LOTIONS; MASSAGE OIL; MASSAGE OILS; NAIL GEL; NATURAL ESSENTIAL OILS; NON-MEDICATED SKIN CARE PREPARATIONS, NAMELY, CREAMS, LOTIONS, GELS, TONERS, CLEANSERS AND PEELS; NON-MEDICATED SKIN CREAMS WITH ESSENTIAL OILS FOR USE IN AROMATHERAPY; NON-MEDICATED SKIN TONERS; PRE-MOISTENED COSMETIC WIPES; SHOWER AND BATH GEL; SKIN CREAMS IN LIQUID AND IN SOLID FORM; SKIN CREAMS IN LIQUID AND SOLID; SKIN CREAMS IN LIQUID AND SOLID FORM; SKIN MOISTURIZING GEL; SKIN TONERS; WASHING-UP LIQUIDS; WIPES IMPREGNATED WITH A SKIN CLEANSER (U.S. CLS. 1, 4, 6, 50, 51 AND 52).

CLASS 5—PHARMACEUTICALS

FOR ANTISEPTIC WIPES; DISPOSABLE SANITIZING WIPES; DISPOSABLE WIPES IMPREGNATED WITH DISINFECTING CHEMICALS OR COMPOUNDS THEREFOR FOR USE IN HOSPITALS, OFFICES, HOTELS, AND MOTELS; DISPOSABLE WIPES IMPREGNATED WITH DISINFECTING CHEMICALS OR COMPOUNDS THEREFOR FOR USE ON RAILINGS, PANELS, COUNTERTOPS, DESKTOPS, AND TOILET SEATS; MEDICATED PRE-MOISTENED WIPES; PRE-MOISTENED MEDICATED WIPES; SANITIZING WIPES (U.S. CLS. 6, 18, 44, 46, 51 AND 52).

KATHLEEN KOLACZ, EXAMINING ATTORNEY

SN 85-429,483. HUFFY CORPORATION, CENTERVILLE, OH. FILED 9-22-2011.

HUFFY

THE MARK CONSISTS OF STANDARD CHARACTERS WITHOUT CLAIM TO ANY PARTICULAR FONT, STYLE, SIZE, OR COLOR.

OWNER OF U.S. REG. NOS. 540,150, 2,352,005 AND OTHERS.

CLASS 6—METAL GOODS

FOR METAL BICYCLE STORAGE RACKS; BICYCLE LOCKS; METAL BICYCLE STORAGE HOOKS (U.S. CLS. 2, 12, 13, 14, 23, 25 AND 50).

CLASS 9—ELECTRICAL AND SCIENTIFIC APPARATUS

FOR BICYCLE HELMETS; ARTICLES OF PROTECTIVE CLOTHING FOR WEAR BY CYCLISTS FOR PROTECTION AGAINST ACCIDENT OR INJURY, NAMELY, KNEE PADS, ELBOW PADS, AND BIKING GLOVES; CYCLE COMPUTERS, SPEEDOMETERS, ODOMETERS (U.S. CLS. 21, 23, 26, 36 AND 38).

CLASS 11—ENVIRONMENTAL CONTROL APPARATUS

FOR BICYCLE REFLECTORS; BICYCLE LIGHTS; BICYCLE LIGHT SYSTEMS COMPRISING HEADLIGHTS, TAILLIGHTS, BLINKERS, LIGHTED FRAME PADS, LIGHTED HANDLEBAR PLAQUES, AND LIGHTED HANDLEBAR PADS (U.S. CLS. 13, 21, 23, 31 AND 34).

CLASS 12—VEHICLES

FOR BICYCLE SADDLES, BICYCLE SADDLE COVERS, BICYCLE PUMPS, TIRE INFLATORS, AIR PUMPS FOR TWO-WHEELED MOTOR VEHICLES OR BICYCLES, BICYCLE PEDALS, WATER BOTTLE CAGES FOR BICYCLES, BICYCLE MIRRORS, BICYCLE HANDLEBAR GRIPS, TIRES, INNER TUBES FOR BICYCLES; BICYCLE PARTS, NAMELY, TUBES AND CONNECTORS FOR BICYCLE FRAMES; KICKSTANDS, BICYCLE TRAINING WHEELS, BICYCLE HORNS, BICYCLE BELLS, PANNIER BAGS FOR BICYCLES, FITTED BICYCLE COVERS, MUD GUARDS FOR BICYCLES, BICYCLE FENDERS; CHILDREN'S NOVELTY BIKE ACCESSORIES, NAMELY, HORNS, BELLS, BASKETS, MIRRORS, HANDLEBAR BAGS, HANDLEBAR PLAQUES, AND HANDLEBAR CASES (U.S. CLS. 19, 21, 23, 31, 35 AND 44).

CLASS 21—HOUSEWARES AND GLASS

FOR EMPTY WATERS BOTTLES FOR BICYCLES (U.S. CLS. 2, 13, 23, 29, 30, 33, 40 AND 50).
GRETTA YAO, EXAMINING ATTORNEY

SN 85-429,508. SXSXW, INC., AUSTIN, TX. FILED 9-22-2011.

SXSXW ACCELERATOR

THE MARK CONSISTS OF STANDARD CHARACTERS WITHOUT CLAIM TO ANY PARTICULAR FONT, STYLE, SIZE, OR COLOR.

OWNER OF U.S. REG. NOS. 2,043,596, 3,773,290 AND OTHERS.

CLASS 35—ADVERTISING AND BUSINESS

FOR ORGANIZING AND CONDUCTING BUSINESS COMPETITIONS FOR START-UP AND EMERGING COMPANIES IN THE FIELD OF INNOVATIVE ONLINE TECHNOLOGIES (U.S. CLS. 100, 101 AND 102).

FIRST USE 12-1-2008; IN COMMERCE 12-1-2008.

CLASS 41—EDUCATION AND ENTERTAINMENT

FOR EDUCATIONAL AND ENTERTAINMENT SERVICES, NAMELY, CONDUCTING LIVE COMPETITIONS BETWEEN BUSINESSES IN THE FIELD OF INNOVATIVE ONLINE TECHNOLOGIES FOR PURPOSES OF ENTERTAINMENT AND EDUCATION (U.S. CLS. 100, 101 AND 107).

FIRST USE 12-1-2008; IN COMMERCE 12-1-2008.

KATHERINE E. HALMEN, EXAMINING ATTORNEY

SN 85-429,752. MIRAE ASSET GLOBAL INVESTMENTS (USA) LLC, NEW YORK, NY. FILED 9-22-2011.

Emerging Markets Insight

THE MARK CONSISTS OF STANDARD CHARACTERS WITHOUT CLAIM TO ANY PARTICULAR FONT, STYLE, SIZE, OR COLOR.

NO CLAIM IS MADE TO THE EXCLUSIVE RIGHT TO USE "EMERGING MARKETS", APART FROM THE MARK AS SHOWN.

CLASS 9—ELECTRICAL AND SCIENTIFIC APPARATUS

FOR DOWNLOADABLE ELECTRONIC PUBLICATIONS IN THE NATURE OF OFFERING FINANCIAL INFORMATION AND ADVICE IN THE FIELD OF INVESTMENTS, BUSINESS AND FINANCE; ELECTRONIC PUBLICATIONS, NAMELY, E-ZINES FEATURING INFORMATIONAL PIECES IN THE FIELD OF INVESTMENTS, BUSINESS AND FINANCE RECORDED ON COMPUTER MEDIA (U.S. CLS. 21, 23, 26, 36 AND 38).

FIRST USE 9-22-2011; IN COMMERCE 9-22-2011.

CLASS 16—PAPER GOODS AND PRINTED MATTER

FOR NEWSLETTERS, BROCHURES, AND MAGAZINES IN THE FIELDS OF SECURITIES, OPTIONS, BONDS AND OTHER FINANCIAL INSTRUMENTS; PRINTED MATTER, NAMELY, NEWSPAPERS, PHOTOGRAPHS, MAGAZINES, BOOKS, PRINTED PERIODICALS, NEWSLETTERS, AND BROCHURES ALL IN THE FIELDS OF SECURITIES, OPTIONS AND OTHER FINANCIAL INSTRUMENTS (U.S. CLS. 2, 5, 22, 23, 29, 37, 38 AND 50).

FIRST USE 9-22-2011; IN COMMERCE 9-22-2011.

CHRISTINA SOBRAL, EXAMINING ATTORNEY

SN 85-430,303. RNK, LLC, MT. VERNON, NY. FILED 9-23-2011.

RNK DISTRIBUTING

THE MARK CONSISTS OF STANDARD CHARACTERS WITHOUT CLAIM TO ANY PARTICULAR FONT, STYLE, SIZE, OR COLOR.

NO CLAIM IS MADE TO THE EXCLUSIVE RIGHT TO USE "DISTRIBUTING", APART FROM THE MARK AS SHOWN.

CLASS 9—ELECTRICAL AND SCIENTIFIC APPARATUS

FOR COMPUTER SOFTWARE FOR DESIGNING AND CREATING EMBROIDERY DESIGNS (U.S. CLS. 21, 23, 26, 36 AND 38).

CLASS 16—PAPER GOODS AND PRINTED MATTER

FOR PAPER USED AS A BACKING FOR STABILIZING EMBROIDERY; ADHESIVE COATED PAPER FOR MAKING TEMPLATES FOR EMBROIDERY; SELF-ADHESIVE EMBROIDERY DESIGN PLACEMENT PAPER; PLASTIC FILM USED AS A TOPPING OR STABILIZER FOR EMBROIDERY NOT FOR COMMERCIAL OR INDUSTRIAL PURPOSES; ADHESIVE URETHANE FILM FOR APPLICATION BY HEAT FOR ADHERING PATCHES, APPLIQUES, EMBROIDERIES AND THE LIKE TO FABRIC NOT FOR COMMERCIAL OR INDUSTRIAL PURPOSES; HEAT FUSIBLE SHEETS IN THE NATURE OF PAPER HAVING AN ADHESIVE COATED SURFACE FOR AFFIXING APPLIQUES (U.S. CLS. 2, 5, 22, 23, 29, 37, 38 AND 50).

CLASS 17—RUBBER GOODS

FOR PLASTIC FILM USED AS A TOPPING OR STABILIZER FOR EMBROIDERY FOR COMMERCIAL OR INDUSTRIAL PURPOSES; ADHESIVE URETHANE FILM FOR APPLICATION BY HEAT FOR ADHERING PATCHES, APPLIQUES, EMBROIDERIES AND THE LIKE TO FABRIC FOR COMMERCIAL OR INDUSTRIAL PURPOSES (U.S. CLS. 1, 5, 12, 13, 35 AND 50).

CLASS 22—CORDAGE AND FIBERS

FOR FUSIBLE POLYESTER BATTING USED AS A QUILT BACKING FOR FABRIC (U.S. CLS. 1, 2, 7, 19, 22, 42 AND 50).

CLASS 23—YARNS AND THREADS

FOR EMBROIDERY THREAD, EMBROIDERY YARN; KIT FOR MAKING FABRIC RESEMBLING KNITTING COMPRISING YARN AND A WASHAWAY PAPER BACKING MATERIAL INTO WHICH THE YARN IS TO BE SEWN (U.S. CL. 43).

CLASS 24—FABRICS

FOR FABRIC USED AS A BACKING FOR STABILIZING EMBROIDERY; ADHESIVE FABRIC FOR APPLICATION BY HEAT FOR ADHERING PATCHES, APPLIQUES, EMBROIDERIES, AND THE LIKE TO FABRIC; HEAT SENSITIVE SHAPE RETAINING FABRIC LINERS FOR IMPARTING STIFFNESS TO ARTICLES MADE OF FABRIC (U.S. CLS. 42 AND 50).
ANDREA BUTLER, EXAMINING ATTORNEY

SN 85-430,701. SCVNGR, INC., CAMBRIDGE, MA. FILED 9-23-2011.

LEVELUP

THE MARK CONSISTS OF STANDARD CHARACTERS WITHOUT CLAIM TO ANY PARTICULAR FONT, STYLE, SIZE, OR COLOR.

OWNER OF U.S. REG. NOS. 4,050,829 AND 4,050,830.

CLASS 9—ELECTRICAL AND SCIENTIFIC APPARATUS

FOR COMPUTER APPLICATION SOFTWARE FOR MOBILE PHONES, PORTABLE ELECTRONIC DEVICES, AND WIRELESS DEVICES, NAMELY, SOFTWARE THAT PROVIDES AN ELECTRONIC FINANCIAL PLATFORM THAT ACCOMMODATES MULTIPLE TYPES OF PAYMENT AND DEBT TRANSACTIONS, INCLUDING USE OF VISUALIZED PAYMENT CODES AT THE POINT OF SALE, AND SOFTWARE FOR PAYMENT AND PAYMENT MANAGEMENT INTEGRATING USER IDENTIFICATION, DISCOUNTS AND PROMOTIONS; ELECTRONIC AND MAGNETIC ID CARDS FOR USE IN CONNECTION WITH PAYMENT FOR GOODS AND SERVICES (U.S. CLS. 21, 23, 26, 36 AND 38).

FIRST USE 7-14-2011; IN COMMERCE 7-14-2011.

CLASS 36—INSURANCE AND FINANCIAL

FOR FINANCIAL TRANSACTION SERVICES, NAMELY, PROVIDING COMMERCIAL TRANSACTIONS AND PAYMENT OPTIONS; FINANCIAL TRANSACTION SERVICES, NAMELY, PROVIDING COMMERCIAL TRANSACTIONS AND PAYMENT OPTIONS THAT USE VISUALIZED PAYMENT CODES AT THE POINT OF SALE; FINANCIAL TRANSACTION SERVICES, NAMELY, PROVIDING COMMERCIAL TRANSACTIONS AND PAYMENT OPTIONS USING A MOBILE DEVICE AT THE POINT OF SALE; FINANCIAL TRANSACTION SERVICES, NAMELY, PROVIDING COMMERCIAL TRANSACTIONS AND PAYMENT OPTIONS INTEGRATING CUSTOMER IDENTIFICATION, DISCOUNTS, AND PROMOTIONS; LOYALTY COUPON PAYMENT PROCESSING SERVICES (U.S. CLS. 100, 101 AND 102).

FIRST USE 7-14-2011; IN COMMERCE 7-14-2011.
SARA BENJAMIN, EXAMINING ATTORNEY

SN 85-431,423. SIRACUSA MANAGEMENT S.A., PANAMA CITY, PANAMA, FILED 9-25-2011.

VPORN

THE MARK CONSISTS OF STANDARD CHARACTERS WITHOUT CLAIM TO ANY PARTICULAR FONT, STYLE, SIZE, OR COLOR.

CLASS 9—ELECTRICAL AND SCIENTIFIC APPARATUS

FOR DIGITAL MEDIA, NAMELY, DVDS AND DOWNLOADABLE VIDEO FILES FEATURING ADULT ENTERTAINMENT; DOWNLOADABLE ADULT-THEMED IMAGES, AUDIO AND FILMS PROVIDED VIA A VIDEO-ON-DEMAND SERVICE (U.S. CLS. 21, 23, 26, 36 AND 38).

CLASS 38—COMMUNICATION

FOR AUDIO AND VIDEO BROADCASTING SERVICES, NAMELY, PROVISION OF TELECOMMUNICATIONS ACCESS TO PHOTOGRAPHS, VIDEO, AUDIO AND OTHER MULTIMEDIA CONTENT FEATURING ADULT ENTERTAINMENT AND RELATED THEMES, ALL PROVIDED VIA AN ON-DEMAND SERVICE OVER THE INTERNET OR OTHER COMMUNICATION NETWORK; AUDIO AND VIDEO BROADCASTING SERVICES, FEATURING THE UPLOADED, POSTED AND TAGGED ADULT-THEMED INFORMATION, PHOTOGRAPHS, AUDIO, AND VIDEO CLIPS OF OTHERS; ELECTRONICALLY TRANSMITTING ADULT-THEMED INFORMATION, PHOTOGRAPHS, AUDIO, AND VIDEO CLIPS; PROVIDING ACCESS TO DATA ON THE INTERNET IN THE FIELD OF ADULT-THEMED INFORMATION, PHOTOGRAPHS, AUDIO, AND VIDEO; PROVIDING ON-LINE FORUMS, CHAT ROOMS, AND LISTSERVICES FOR TRANSMISSION OF MESSAGES AMONG COMPUTER USERS IN THE FIELD OF ADULT-THEMED ENTERTAINMENT; PROVIDING ON-LINE CHAT ROOMS AND ELECTRONIC BULLETIN BOARDS FOR TRANSMISSION OF MESSAGES AMONG USERS IN THE FIELD OF ADULT-THEMED INTERESTS; STREAMING OF AUDIO, VISUAL AND AUDIO-VISUAL MATERIAL VIA A GLOBAL COMPUTER NETWORK OR OTHER COMMUNICATION NETWORK; INTERACTIVE ELECTRONIC DELIVERY OF PHOTOGRAPHS, AUDIO AND VIDEO OVER DIGITAL NETWORKS (U.S. CLS. 100, 101 AND 104).

CLASS 41—EDUCATION AND ENTERTAINMENT

FOR ENTERTAINMENT AND EDUCATION SERVICES, NAMELY, PROVIDING AN ONLINE WEB SITE FEATURING INFORMATION AND NON-DOWNLOADABLE PHOTOGRAPHS, AUDIO, VIDEOS AND MULTIMEDIA MATERIALS IN THE FIELD OF ADULT ENTERTAINMENT (U.S. CLS. 100, 101 AND 107).

CLASS 42—SCIENTIFIC AND COMPUTER SERVICES

FOR PROVIDING A WEB SITE THAT GIVES COMPUTER USERS THE ABILITY TO UPLOAD, POST, SHOW, DISPLAY AND TAG ADULT-THEMED INFORMATION, PHOTOGRAPHS, AUDIO, AND VIDEO CLIPS (U.S. CLS. 100 AND 101).

JAMES GRIFFIN, EXAMINING ATTORNEY

SN 85-431,586. CELESTINA, DANIEL, PALM DESERT, CA. FILED 9-26-2011.



NO CLAIM IS MADE TO THE EXCLUSIVE RIGHT TO USE "ULTIMATE KARAOKE CHAMPIONSHIPS" WITH RESPECT TO THE GOODS AND SERVICES IN CLASSES 9 AND 41, APART FROM THE MARK AS SHOWN.

THE STIPPLING IS FOR SHADING PURPOSES ONLY.

THE MARK CONSISTS OF THE STYLIZED TEXT "ULTIMATE KARAOKE CHAMPIONSHIPS" WITH EACH WORD STACKED UPON THE NEXT. ON EACH SIDE OF THE TEXT ARE VERTICAL BARS RESEMBLING BASE LEVELS. UNDER "CHAMPIONSHIPS" IS A MIRROR IMAGE OF THE WORD.

CLASS 9—ELECTRICAL AND SCIENTIFIC APPARATUS

FOR VIDEO RECORDINGS FEATURING KARAOKE COMPETITIONS (U.S. CLS. 21, 23, 26, 36 AND 38).

CLASS 25—CLOTHING

FOR HATS; JACKETS; SHIRTS; WRISTBANDS (U.S. CLS. 22 AND 39).

CLASS 41—EDUCATION AND ENTERTAINMENT

FOR ENTERTAINMENT IN THE NATURE OF COMPETITIONS IN THE FIELD OF KARAOKE (U.S. CLS. 100, 101 AND 107).

MICHELE SWAIN, EXAMINING ATTORNEY

SN 85-432,024. LOWELL INTERNATIONAL COMPANY, FRANKLIN PARK, IL. FILED 9-26-2011.

Happy Fruits

THE MARK CONSISTS OF STANDARD CHARACTERS WITHOUT CLAIM TO ANY PARTICULAR FONT, STYLE, SIZE, OR COLOR.

NO CLAIM IS MADE TO THE EXCLUSIVE RIGHT TO USE "FRUITS", APART FROM THE MARK AS SHOWN.

CLASS 29—MEATS AND PROCESSED FOODS

FOR FROZEN FRUITS; FRUIT PRESERVES (U.S. CL. 46).

CLASS 32—LIGHT BEVERAGES

FOR FRUIT BEVERAGES; FRUIT DRINKS; FRUIT JUICES; FRUIT NECTARS; SYRUPS FOR MAKING FRUIT-FLAVORED DRINKS (U.S. CLS. 45, 46 AND 48).

KATHLEEN KOLACZ, EXAMINING ATTORNEY

SN 85-432,214. KABUSHIKI KAISHA SEGA D/B/A SEGA CORPORATION, TOKYO, JAPAN, FILED 9-26-2011.



OWNER OF U.S. REG. NO. 3,257,282.

THE MARK CONSISTS OF THE WORD "YAKUZA" IN STYLIZED FONT OVER THE WORDS "DEAD SOULS" IN SMALLER TYPE, WITH A LONG HYPHEN ON EITHER SIDE.

THE ENGLISH TRANSLATION OF "YAKUZA" IN THE MARK IS "A LOOSE ALLIANCE OF JAPANESE CRIMINAL ORGANIZATIONS AND CRIMINAL ENTERPRISES; A JAPANESE GANGSTER; OR JAPANESE MAFIA".

CLASS 9—ELECTRICAL AND SCIENTIFIC APPARATUS

FOR VIDEO GAME SOFTWARE; COMPUTER GAME PROGRAMS; DOWNLOADABLE GRAPHICS, IMAGES AND MOVING IMAGES FOR COMPUTERS OR MOBILE PHONES FEATURING SCENES AND CHARACTERS BASED ON COMPUTER AND VIDEO GAMES (U.S. CLS. 21, 23, 26, 36 AND 38).

SN 85-432,340. PROSPECT PARK NETWORKS, LLC, LOS ANGELES, CA. FILED 9-26-2011.

CLASS 41—EDUCATION AND ENTERTAINMENT

FOR ENTERTAINMENT SERVICES, NAMELY, PROVIDING ON-LINE VIDEO GAMES AND ON-LINE COMPUTER GAMES; PROVIDING INFORMATION ABOUT ONLINE VIDEO AND COMPUTER GAMES; PROVIDING NON-DOWNLOADABLE ON-LINE GRAPHICS, MOVING IMAGES, IMAGES BY COMPUTER NETWORKS OR MOBILE PHONES FEATURING SCENES AND CHARACTERS BASED ON COMPUTER AND VIDEO GAMES (U.S. CLS. 100, 101 AND 107).

ELI HELLMAN, EXAMINING ATTORNEY

TOLN

THE MARK CONSISTS OF STANDARD CHARACTERS WITHOUT CLAIM TO ANY PARTICULAR FONT, STYLE, SIZE, OR COLOR.

SN 85-432,220. WACO FILTERS CORPORATION, NORRISTOWN, PA. FILED 9-26-2011.

WACO FILTERS

THE MARK CONSISTS OF STANDARD CHARACTERS WITHOUT CLAIM TO ANY PARTICULAR FONT, STYLE, SIZE, OR COLOR.

NO CLAIM IS MADE TO THE EXCLUSIVE RIGHT TO USE "FILTERS", APART FROM THE MARK AS SHOWN.

CLASS 7—MACHINERY

FOR GAS FILTERS FOR COMMERCIAL AND INDUSTRIAL APPLICATIONS; FILTERS FOR COMMERCIAL AND INDUSTRIAL MACHINES; FUEL AND OIL FILTERS (U.S. CLS. 13, 19, 21, 23, 31, 34 AND 35).

FIRST USE 8-1-2011; IN COMMERCE 8-1-2011.

CLASS 11—ENVIRONMENTAL CONTROL APPARATUS

FOR AIR FILTERS FOR COMMERCIAL AND INDUSTRIAL APPLICATIONS; WATER FILTERS (U.S. CLS. 13, 21, 23, 31 AND 34).

FIRST USE 8-1-2011; IN COMMERCE 8-1-2011.

CLASS 35—ADVERTISING AND BUSINESS

FOR DISTRIBUTORSHIP SERVICES FOR FILTRATION PRODUCTS (U.S. CLS. 100, 101 AND 102).

FIRST USE 8-1-2011; IN COMMERCE 8-1-2011.

CLASS 37—CONSTRUCTION AND REPAIR

FOR INSTALLATION AND MAINTENANCE OF FILTRATION PRODUCTS (U.S. CLS. 100, 103 AND 106).

FIRST USE 8-1-2011; IN COMMERCE 8-1-2011.

CHRISTINE MARTIN, EXAMINING ATTORNEY

CLASS 9—ELECTRICAL AND SCIENTIFIC APPARATUS

FOR DOWNLOADABLE AUDIO-VISUAL CONTENT IN THE FIELDS OF NEWS, CURRENT EVENTS, ENTERTAINMENT, SPORTS, COMEDY, DRAMA, SOAP OPERAS, ANIMATION, MUSIC, AND MUSIC VIDEOS; COMPUTER APPLICATION SOFTWARE FOR MOBILE PHONES AND OTHER ELECTRONIC DEVICES FOR DOWNLOADING PRE-RECORDED AUDIO-VISUAL RECORDINGS FEATURING TELEVISION PROGRAMS AND MULTIMEDIA ENTERTAINMENT CONTENT FEATURING NEWS, CURRENT EVENTS, ENTERTAINMENT, SPORTS, COMEDY, DRAMA, SOAP OPERAS, ANIMATION, MUSIC, AND MUSIC VIDEOS, AND ALSO FOR THE DISTRIBUTION OF MULTIMEDIA CONTENT CONTAINING TEXT, GRAPHICS, IMAGES, AUDIO AND VIDEO IN THE FIELD OF TELEVISION PROGRAMS AND MULTIMEDIA ENTERTAINMENT CONTENT FEATURING NEWS, CURRENT EVENTS, ENTERTAINMENT, SPORTS, COMEDY, DRAMA, SOAP OPERAS, ANIMATION, MUSIC, AND MUSIC VIDEOS; COMPUTER SOFTWARE FOR DOWNLOADING PRE-RECORDED AUDIO-VISUAL AND MULTIMEDIA ENTERTAINMENT CONTENT; AND ALSO FOR THE DISTRIBUTION OF MULTIMEDIA CONTENT; COMPUTER SOFTWARE FOR STREAMING AUDIO-VISUAL CONTENT VIA THE INTERNET AND TO MOBILE DIGITAL ELECTRONIC DEVICES; DOWNLOADABLE COMPUTER SOFTWARE FOR STREAMING AUDIOVISUAL CONTENT; SOFTWARE TOOLS FOR EDITING OF AUDIO-VISUAL CONTENT; VIDEO SEARCH AND ANNOTATION SOFTWARE; CONTENT PROTECTION SOFTWARE FOR SECURE VIDEO AND MULTIMEDIA STORAGE; AD TRACKING AND OPTIMIZATION SOFTWARE; SOFTWARE PLATFORMS FOR PROVIDING PROGRAMMATIC INTERFACES FOR THIRD PARTIES TO ACCESS WEBSITE CONTENT AND DATA FOR WEB DEVELOPMENT AND WEBSITE APPLICATION DEVELOPMENT; COVERS FOR PERSONAL DIGITAL ASSISTANTS AND CELL PHONES; COMPUTER GAME SOFTWARE; DOWNLOADABLE ELECTRONIC GAMES FOR USE WITH PERSONAL COMPUTERS, MOBILE PHONES, AND OTHER ELECTRONIC DEVICES (U.S. CLS. 21, 23, 26, 36 AND 38).

CLASS 35—ADVERTISING AND BUSINESS

FOR BUSINESS TO BUSINESS ADVERTISING; ON-LINE BANNER ADVERTISING AND MARKETING SERVICES; ONLINE RETAIL SHOPPING SITE SERVICES FEATURING STREAMING OR DOWNLOADABLE AUDIO-VISUAL CONTENT FEATURING NEWS, CURRENT EVENTS, ENTERTAINMENT, SPORTS, COMEDY, DRAMA, SOAP OPERAS, ANIMATION, MUSIC, AND MUSIC VIDEOS (U.S. CLS. 100, 101 AND 102).

CLASS 38—COMMUNICATION

FOR BROADCASTING AND STREAMING OF AUDIO-VISUAL CONTENT FEATURING NEWS, CURRENT EVENTS, ENTERTAINMENT, SPORTS, COMEDY, DRAMA, SOAP OPERAS, ANIMATION, MUSIC, AND MUSIC VIDEOS VIA A GLOBAL COMPUTER NETWORK; TRANSMISSION OF DOWNLOADABLE AUDIO-VISUAL CONTENT IN THE NATURE OF FULL-LENGTH, PARTIAL-LENGTH, AND CLIPS FOR MOTION PICTURES, TELEVISION PROGRAMMING, VIDEOS, MUSIC VIDEOS, AND MUSIC; PROVIDING ACCESS TO ONLINE FORUMS, CHAT ROOMS, AND BLOGS OVER THE INTERNET; PROVIDING ONLINE ELECTRONIC BULLETIN BOARDS FOR TRANSMISSION OF MESSAGES AMONG USERS IN THE FIELD OF GENERAL INTERESTS; WEB MESSAGING SERVICES; VIDEO ON DEMAND TRANSMISSION SERVICES; PROVIDING ONLINE FORUMS FOR TRANSMISSION OF MESSAGES FEATURING NEWS, CURRENT EVENTS, ENTERTAINMENT, SPORTS, COMEDY, DRAMA, SOAP OPERAS, ANIMATION, MUSIC, AND MUSIC VIDEOS (U.S. CLS. 100, 101 AND 104).

CLASS 41—EDUCATION AND ENTERTAINMENT

FOR PROVIDING AUDIO-VISUAL CONTENT AND OTHER MULTIMEDIA CONTENT FEATURING NEWS, CURRENT EVENTS, ENTERTAINMENT, SPORTS, COMEDY, DRAMA, SOAP OPERAS, ANIMATION, MUSIC, AND MUSIC VIDEOS, DISTRIBUTED VIA VARIOUS PLATFORMS ACROSS MULTIPLE FORMS OF TRANSMISSION MEDIA; PROVIDING INFORMATION VIA VARIOUS PLATFORMS ACROSS MULTIPLE FORMS OF TRANSMISSION MEDIA ON THE SUBJECTS OF MOTION PICTURES, TELEVISION PROGRAMMING, VIDEOS, MUSIC VIDEOS, AND MUSIC; PROVIDING ONLINE INTERACTIVE RESOURCE AND PROGRAMMING GUIDES ON THE SUBJECTS OF MOTION PICTURES, TELEVISION PROGRAMMING, VIDEOS, MUSIC VIDEOS, AND MUSIC TAILORED TO VIEWERS' PROGRAMMING PREFERENCES; PRODUCTION OF TELEVISION PROGRAMS AND MULTIMEDIA ENTERTAINMENT CONTENT FEATURING NEWS, CURRENT EVENTS, ENTERTAINMENT, SPORTS, COMEDY, DRAMA, SOAP OPERAS, ANIMATION, MUSIC, AND MUSIC VIDEOS, FOR DISTRIBUTION VIA VARIOUS PLATFORMS ACROSS MULTIPLE FORMS OF TRANSMISSION MEDIA; PRODUCTION AND RENTAL OF AUDIO-VISUAL WORKS, SPECIFICALLY MOTION PICTURES, TELEVISION PROGRAMMING, VIDEOS, MUSIC VIDEOS, AND MUSIC, FOR STREAMING OR DOWNLOADING FEATURING NEWS, CURRENT EVENTS, ENTERTAINMENT, SPORTS, COMEDY, DRAMA, SOAP OPERAS, ANIMATION, MUSIC, AND MUSIC VIDEOS; PROVIDING BLOGS IN THE NATURE OF AN ONLINE JOURNAL OVER THE INTERNET FEATURING NEWS, CURRENT EVENTS, ENTERTAINMENT, SPORTS, COMEDY, DRAMA, SOAP OPERAS, ANIMATION, MUSIC, AND MUSIC VIDEOS; PROVIDING A WEBSITE FEATURING AUDIO-VISUAL CONTENT, SPECIFICALLY MOTION PICTURES, TELEVISION PROGRAMMING, VIDEOS, MUSIC VIDEOS, AND MUSIC, AND VIDEO CLIPS, AUDIO CLIPS, MUSIC CLIPS, FILM CLIPS, AND PHOTOGRAPHS FEATURING NEWS, CURRENT EVENTS, ENTERTAINMENT, SPORTS, COMEDY, DRAMA, SOAP OPERAS, ANIMATION, MUSIC, AND MUSIC VIDEOS (U.S. CLS. 100, 101 AND 107).

CLASS 42—SCIENTIFIC AND COMPUTER SERVICES

FOR HOSTING OF DIGITAL CONTENT ON THE INTERNET; HOSTING AND MAINTAINING AN ONLINE COMMUNITY FEATURING AUDIO-VISUAL CONTENT IN THE FIELDS OF NEWS, CURRENT EVENTS, ENTERTAINMENT, SPORTS, COMEDY, DRAMA, SOAP OPERAS, ANIMATION, MUSIC, AND MUSIC VIDEOS; PROVIDING PROGRAMMATIC INTERFACES FOR THIRD PARTIES TO ACCESS WEBSITE CONTENT AND DATA FOR WEB DEVELOPMENT AND WEBSITE APPLICATION DEVELOPMENT (U.S. CLS. 100 AND 101).

DAVID TAYLOR, EXAMINING ATTORNEY

SN 85-432,657. HEALTHLOOP, INC., SAN FRANCISCO, CA. FILED 9-27-2011.

MEDICAL MICRO-VISIT

THE MARK CONSISTS OF STANDARD CHARACTERS WITHOUT CLAIM TO ANY PARTICULAR FONT, STYLE, SIZE, OR COLOR.

NO CLAIM IS MADE TO THE EXCLUSIVE RIGHT TO USE "MEDICAL", APART FROM THE MARK AS SHOWN.

CLASS 38—COMMUNICATION

FOR INFORMATION SERVICES IN THE FIELD OF HEALTHCARE, NAMELY, PROVIDING A MESSAGE SENDING AND RECEIVING SERVICE FEATURING RECEIVING AND FORWARDING COMMUNICATIONS BETWEEN PATIENTS AND HEALTHCARE PROVIDERS USING A WEBSITE ACCESSIBLE OVER A GLOBAL COMPUTER NETWORK (U.S. CLS. 100, 101 AND 104).

CLASS 39—TRANSPORTATION AND STORAGE

FOR INFORMATION SERVICES IN THE FIELD OF HEALTHCARE, NAMELY, ELECTRONIC STORAGE OF COMMUNICATION MESSAGES BETWEEN PATIENTS AND HEALTHCARE PROVIDERS USING A WEBSITE ACCESSIBLE OVER A GLOBAL COMPUTER NETWORK (U.S. CLS. 100 AND 105).

CLASS 44—MEDICAL, BEAUTY AND AGRICULTURAL SERVICES

FOR MEDICAL INFORMATION SERVICES IN THE FIELD OF HEALTHCARE, NAMELY, REPORTING OF CONSUMER AUTHORIZED CLINICAL TESTING RESULTS DIRECTLY TO THE PATIENT BY HEALTHCARE PROVIDERS USING A WEBSITE ACCESSIBLE OVER A GLOBAL COMPUTER NETWORK (U.S. CLS. 100 AND 101).

EMILY CHUO, EXAMINING ATTORNEY

SN 85-432,739. BRACEWELL & GIULIANI LLP, HOUSTON, TX. FILED 9-27-2011.

THE MARK CONSISTS OF THE WORD "BASIS" ABOVE THE WORD "POINTS" WITH A HORIZONTAL LINE SITUATED ABOVE AND BELOW BOTH WORDS.

CLASS 41—EDUCATION AND ENTERTAINMENT

FOR ON-LINE JOURNALS, NAMELY, BLOGS FEATURING LEGISLATIVE AND LEGAL ISSUES AND COMMENTARY ON RESTRUCTURING AND DISTRESSED DEBT PROVIDED TO CORPORATIONS, CORPORATE EXECUTIVES, AND INVESTING AND RESTRUCTURING PROFESSIONALS (U.S. CLS. 100, 101 AND 107).

FIRST USE 6-7-2010; IN COMMERCE 6-7-2010.

CLASS 45—PERSONAL AND LEGAL SERVICES

FOR INFORMATION AND NEWS IN THE FIELD OF LAW PROVIDED TO CORPORATIONS, CORPORATE EXECUTIVES, AND INVESTING AND RESTRUCTURING PROFESSIONALS (U.S. CLS. 100 AND 101).

FIRST USE 6-7-2010; IN COMMERCE 6-7-2010.

JENNIFER WILLISTON, EXAMINING ATTORNEY

SN 85-432,748. HARSCO TECHNOLOGIES LLC, FAIRMONT, MN. FILED 9-27-2011.

IRON HORSE

THE MARK CONSISTS OF STANDARD CHARACTERS WITHOUT CLAIM TO ANY PARTICULAR FONT, STYLE, SIZE, OR COLOR.

CLASS 3—COSMETICS AND CLEANING PREPARATIONS

FOR SLAG PRODUCTS, NAMELY, ABRASIVES IN THE FORM OF BLAST GRIT AND FRICTION GRANULES FOR USE IN FINISHING, CLEANING AND ABRADING SURFACES OF ALL KINDS (U.S. CLS. 1, 4, 6, 50, 51 AND 52).

CLASS 19—NON-METALLIC BUILDING MATERIALS

FOR NON-METAL ROOFING GRANULES COMPRISED PRIMARILY OF COPPER SLAG FOR THE MANUFACTURE OF SHINGLES, SHEETING AND OTHER ROOFING SURFACES (U.S. CLS. 1, 12, 33 AND 50).

JENNIFER MARTIN, EXAMINING ATTORNEY

SN 85-432,891. JEWISH LEARNING VENTURE, INC., MEL-ROSE PARK, PA. FILED 9-27-2011.

**Jewish Learning Venture**

NO CLAIM IS MADE TO THE EXCLUSIVE RIGHT TO USE "JEWISH LEARNING VENTURE", APART FROM THE MARK AS SHOWN.

THE COLOR(S) ORANGE AND GREY IS/ARE CLAIMED AS A FEATURE OF THE MARK.

THE MARK CONSISTS OF THE STYLIZED WORDING "JEWISH LEARNING VENTURE" SHOWN IN INITIAL CAPITAL LETTER FORMAT IN THE COLOR GREY. ABOVE THE LITERAL PORTION IS A DESIGN WHICH IS REMINISCENT OF THE LETTER "L" ROTATED ON A 45° ANGLE. THE DESIGN IS SHOWN IN THE COLOR ORANGE AND OUTLINED IN THE COLOR GREY.

CLASS 35—ADVERTISING AND BUSINESS

FOR PROMOTING THE INTERESTS OF THE JEWISH COMMUNITY (U.S. CLS. 100, 101 AND 102).

FIRST USE 9-21-2011; IN COMMERCE 9-21-2011.

CLASS 41—EDUCATION AND ENTERTAINMENT

FOR JEWISH COMMUNITY OUTREACH SERVICES, NAMELY, PROVIDING EDUCATIONAL PROGRAMS IN THE FIELD OF JEWISH COMMUNITY PRACTICES; AND JEWISH RELIGIOUS EDUCATIONAL SERVICES, NAMELY, WORKSHOPS, CONFERENCES, CONSULTATION, COACHING AND MENTORING TO INDIVIDUALS AND INSTITUTIONS (U.S. CLS. 100, 101 AND 107).

FIRST USE 9-21-2011; IN COMMERCE 9-21-2011.

GEOFFREY FOSDICK, EXAMINING ATTORNEY

SN 85-433,051. PHARMACY AND HEALTHCARE COMMUNICATIONS, LLC, PLAINSBORO, NJ. FILED 9-27-2011.

PHARMACY CAREERS

THE MARK CONSISTS OF STANDARD CHARACTERS WITHOUT CLAIM TO ANY PARTICULAR FONT, STYLE, SIZE, OR COLOR.

OWNER OF U.S. REG. NO. 3,072,255.

SEC. 2(F).

CLASS 16—PAPER GOODS AND PRINTED MATTER

FOR PUBLICATIONS, NAMELY, MAGAZINES AND SUPPLEMENTS TO THE FOREGOING IN THE FIELD OF PHARMACY (U.S. CLS. 2, 5, 22, 23, 29, 37, 38 AND 50).

FIRST USE 4-1-2000; IN COMMERCE 4-1-2000.

CLASS 35—ADVERTISING AND BUSINESS

FOR ADVERTISING, MARKETING, AND PROMOTING THE GOODS AND SERVICES OF OTHERS VIA PROVIDING SPACE IN MAGAZINES AND SUPPLEMENTS TO THE FOREGOING (U.S. CLS. 100, 101 AND 102).

FIRST USE 4-1-2000; IN COMMERCE 4-1-2000.

CLASS 41—EDUCATION AND ENTERTAINMENT

FOR NON-DOWNLOADABLE ELECTRONIC PUBLICATIONS IN THE NATURE OF MAGAZINES AND SUPPLEMENTS TO THE FOREGOING IN THE FIELD OF PHARMACY (U.S. CLS. 100, 101 AND 107).

FIRST USE 4-1-2000; IN COMMERCE 4-1-2000.

AMY KELLY, EXAMINING ATTORNEY

SN 85-433,094. ADVANCE MAGAZINE PUBLISHERS INC., NEW YORK, NY. FILED 9-27-2011.

SN 85-434,152. WHITE, DANIEL, AUSTIN, TX. FILED 9-28-2011.

THE CARTOON BANK

THE MARK CONSISTS OF STANDARD CHARACTERS WITHOUT CLAIM TO ANY PARTICULAR FONT, STYLE, SIZE, OR COLOR.

OWNER OF U.S. REG. NO. 3,033,725.
NO CLAIM IS MADE TO THE EXCLUSIVE RIGHT TO USE "CARTOON", APART FROM THE MARK AS SHOWN.

CLASS 35—ADVERTISING AND BUSINESS

FOR ONLINE STORE SERVICES FEATURING FRAMED AND UNFRAMED CARTOON PRINTS, MAGAZINE COVERS AND PHOTOS, APPAREL, BOOKS, STATIONERY, NOTE CARDS (U.S. CLS. 100, 101 AND 102).

FIRST USE 9-1-1998; IN COMMERCE 9-1-1998.

CLASS 45—PERSONAL AND LEGAL SERVICES

FOR ONLINE LICENSING OF CARTOONS AND MAGAZINE COVERS (U.S. CLS. 100 AND 101).
FIRST USE 9-1-1998; IN COMMERCE 9-1-1998.
TRACY FLETCHER, EXAMINING ATTORNEY



THE COLOR(S) BLUE, ORANGE, WHITE AND GREY IS/ ARE CLAIMED AS A FEATURE OF THE MARK.

THE MARK CONSISTS OF THE TERM "HI" AND AN EXCLAMATION POINT IN WHITE STYLIZED LETTERS. THE LETTERING APPEARS ON AN ORANGE SQUARE WITH ROUNDED CORNERS WITH A POINTED SHAPE ON THE BOTTOM LEFT SIDE OF THE ORANGE SQUARE. BEHIND THE ORANGE SQUARE IS A BLUE SQUARE WITH ROUNDED CORNERS WITH A GREY SHADOW ON THE BOTTOM AND RIGHT SIDE.

CLASS 9—ELECTRICAL AND SCIENTIFIC APPARATUS

FOR COMPUTER APPLICATION SOFTWARE FOR MOBILE PHONES, NAMELY, SOFTWARE FOR MOBILE BASED RELATIONSHIP BUILDING AND FOR THE PURPOSE OF MEETING NEW PEOPLE AND MAKING FRIENDS WITHIN A SPECIFIC GEOGRAPHIC LOCATION AND/OR COMMUNITY (U.S. CLS. 21, 23, 26, 36 AND 38).

CLASS 25—CLOTHING

FOR T-SHIRTS; HATS (U.S. CLS. 22 AND 39).

CLASS 45—PERSONAL AND LEGAL SERVICES

FOR PROVIDING AN INTERACTIVE WEBSITE FEATURING INFORMATION AND CONTENT IN THE FIELD OF PERSONAL RELATIONSHIPS AND FOR THE PURPOSE OF MEETING NEW PEOPLE AND MAKING FRIENDS WITHIN A SPECIFIC GEOGRAPHIC LOCATION AND/OR COMMUNITY (U.S. CLS. 100 AND 101).

DOMINIC J. FERRAIUOLO, EXAMINING ATTORNEY

SN 85-434,097. VALEN TECHNOLOGIES, INC., DENVER, CO. FILED 9-28-2011.

VALEN

THE MARK CONSISTS OF STANDARD CHARACTERS WITHOUT CLAIM TO ANY PARTICULAR FONT, STYLE, SIZE, OR COLOR.

OWNER OF U.S. REG. NO. 3,830,145.
SEC. 2(F).

CLASS 35—ADVERTISING AND BUSINESS

FOR DATA COMPILING AND ANALYZING IN THE FIELD OF INSURANCE (U.S. CLS. 100, 101 AND 102).
FIRST USE 10-15-2002; IN COMMERCE 10-15-2002.

CLASS 42—SCIENTIFIC AND COMPUTER SERVICES

FOR APPLICATION SERVICE PROVIDER (ASP) FEATURING SOFTWARE FOR USE IN ANALYTICAL AND STATISTICAL MODELS FOR THE UNDERSTANDING AND PREDICTING OF UNDERWRITING TRENDS, ACTIONS AND OPTIMIZING PREMIUM AUDIT PROCESSES; COMPUTER SITE DESIGN (U.S. CLS. 100 AND 101).

FIRST USE 10-15-2002; IN COMMERCE 10-15-2002.
BRENDAN REGAN, EXAMINING ATTORNEY

SN 85-434,341. SANJAY NAMBIAR, LOS ANGELES, CA. FILED 9-28-2011.

A Little Zen for Little Ones

THE MARK CONSISTS OF STANDARD CHARACTERS WITHOUT CLAIM TO ANY PARTICULAR FONT, STYLE, SIZE, OR COLOR.

CLASS 16—PAPER GOODS AND PRINTED MATTER

FOR CHILDREN'S ACTIVITY BOOKS; CHILDREN'S BOOKS; CHILDREN'S INTERACTIVE EDUCATIONAL BOOKS; CHILDREN'S STORYBOOKS; CHILDREN'S WALL STICKERS AND MURALS; CHILDREN'S ARTS AND CRAFTS PAPER KITS; COLORING BOOKS; FLIP BOOKS; PERSONALIZED COLORING BOOKS FOR CHILDREN; PICTURE BOOKS; PRINTED CHILDREN'S COLORING PAGES; RELIGIOUS BOOKS; STORY BOOKS; TALKING CHILDREN'S BOOKS (U.S. CLS. 2, 5, 22, 23, 29, 37, 38 AND 50).

FIRST USE 9-1-2011; IN COMMERCE 9-1-2011.

CLASS 41—EDUCATION AND ENTERTAINMENT

FOR BOOK AND REVIEW PUBLISHING; BOOK PUBLISHING; CHILDREN'S ENTERTAINMENT AND AMUSEMENT CENTERS, NAMELY, INTERACTIVE PLAY AREAS; DESKTOP PUBLISHING FOR OTHERS; DIGITAL VIDEO, AUDIO, AND MULTIMEDIA PUBLISHING SERVICES; EDUCATIONAL AND ENTERTAINMENT SERVICES, NAMELY, PROVIDING ON-LINE INTERACTIVE CHILDREN'S STORIES; ELECTRONIC DESKTOP PUBLISHING; MAGAZINE PUBLISHING; MULTIMEDIA PUBLISHING OF BOOKS, MAGAZINES, JOURNALS, SOFTWARE, GAMES, MUSIC, AND ELECTRONIC PUBLICATIONS; MUSIC PUBLISHING SERVICES; NEWSPAPER PUBLISHING; ONLINE ELECTRONIC PUBLISHING OF BOOKS AND PERIODICALS; ONLINE ELECTRONIC PUBLISHING OF TEXT AND GRAPHIC WORKS OF OTHERS FEATURING INFORMATION REGARDING SECURITIES MARKET SERVICES AND SECURITIES TRADING ACTIVITY, INFORMATION REGARDING PUBLICLY-TRADED COMPANIES AND OTHER FINANCIAL AND BUSINESS INFORMATION; PROVIDING A WEB SITE FEATURING ON-LINE PUBLICATIONS IN THE FIELD OF NEWS ARTICLES FOR CHILDREN; PROVIDING A WEBSITE FEATURING INFORMATION IN THE FIELDS OF EDUCATION AND ENTERTAINMENT FOR CHILDREN; PROVIDING ADVICE AND INFORMATION IN THE FIELD OF EDUCATIONAL AND ENTERTAINMENT ACTIVITIES AND EVENTS FOR CHILDREN; PROVIDING INFORMATION RELATING TO EDUCATION SERVICES FOR CHILDREN; PROVISION OF INFORMATION RELATING TO MULTIMEDIA PUBLISHING; PROVISION OF INFORMATION RELATING TO PUBLISHING OF ELECTRONIC PUBLICATIONS; PUBLISHING OF BOOKS AND REVIEWS; PUBLISHING OF BOOKS, E-BOOKS, AUDIO BOOKS, MUSIC AND ILLUSTRATIONS; PUBLISHING OF BOOKS, MAGAZINES; PUBLISHING OF ELECTRONIC PUBLICATIONS; PUBLISHING OF REVIEWS; PUBLISHING OF WEB MAGAZINES (U.S. CLS. 100, 101 AND 107).

FIRST USE 9-1-2011; IN COMMERCE 9-1-2011.

MATTHEW PAPPAS, EXAMINING ATTORNEY

SN 85-435,157. RADIO CITY TRADEMARKS, LLC, NEW YORK, NY. FILED 9-29-2011.

ROCKETTE

THE MARK CONSISTS OF STANDARD CHARACTERS WITHOUT CLAIM TO ANY PARTICULAR FONT, STYLE, SIZE, OR COLOR.

OWNER OF U.S. REG. NOS. 1,209,117, 2,283,460 AND 2,567,658.

CLASS 25—CLOTHING

FOR CLOTHING, NAMELY, T-SHIRTS (U.S. CLS. 22 AND 39).

FIRST USE 9-19-1986; IN COMMERCE 9-19-1986.

CLASS 28—TOYS AND SPORTING GOODS

FOR TOYS, NAMELY, DOLLS AND STUFFED ANIMALS (U.S. CLS. 22, 23, 38 AND 50).

FIRST USE 0-0-1996; IN COMMERCE 0-0-1996.

CLASS 41—EDUCATION AND ENTERTAINMENT

FOR EDUCATION SERVICES, NAMELY, PROVIDING CLASSES AND INSTRUCTION IN THE FIELD OF DANCE; ENTERTAINMENT SERVICES IN THE NATURE OF LIVE STAGE PERFORMANCES, THEATRICAL PRODUCTIONS, AND CONCERTS, AND LIVE, TELEVISED AND MOVIE APPEARANCES BY PROFESSIONAL DANCERS AND ENTERTAINERS (U.S. CLS. 100, 101 AND 107).

FIRST USE 0-0-1994; IN COMMERCE 0-0-1994.

VIVIAN MICZNIK FIRST, EXAMINING ATTORNEY

SN 85-435,267. ADVANCE MAGAZINE PUBLISHERS INC., NEW YORK, NY. FILED 9-29-2011.

CONDE NAST STORE

THE MARK CONSISTS OF STANDARD CHARACTERS WITHOUT CLAIM TO ANY PARTICULAR FONT, STYLE, SIZE, OR COLOR.

OWNER OF U.S. REG. NOS. 1,568,296, 2,761,342 AND 3,102,717.

NO CLAIM IS MADE TO THE EXCLUSIVE RIGHT TO USE "STORE", APART FROM THE MARK AS SHOWN.

CLASS 35—ADVERTISING AND BUSINESS

FOR ONLINE STORE SERVICES FEATURING FRAMED AND UNFRAMED PRINTS, MAGAZINE COVERS AND PHOTOS, BOOKS, STATIONERY AND NOTE CARDS (U.S. CLS. 100, 101 AND 102).

FIRST USE 3-1-2007; IN COMMERCE 3-1-2007.

CLASS 45—PERSONAL AND LEGAL SERVICES

FOR ONLINE LICENSING OF CARTOON IMAGES (U.S. CLS. 100 AND 101).

FIRST USE 3-1-2007; IN COMMERCE 3-1-2007.

TRACY FLETCHER, EXAMINING ATTORNEY

SN 85-436,002. JOHNSON CONTROLS TECHNOLOGY COMPANY, HOLLAND, MI. FILED 9-30-2011.

LIVE GUIDE

THE MARK CONSISTS OF STANDARD CHARACTERS WITHOUT CLAIM TO ANY PARTICULAR FONT, STYLE, SIZE, OR COLOR.

CLASS 9—ELECTRICAL AND SCIENTIFIC APPARATUS

FOR COMPUTER SOFTWARE FOR THE COLLECTION, TRANSMISSION, STORAGE, SHARING, DIAGNOSIS AND REPORTING OF DATA AND INFORMATION RELATED TO BUILDING ENVIRONMENT, ACCESS AND SECURITY SYSTEMS; COMPUTER SOFTWARE FOR THE MEASUREMENT AND VERIFICATION OF CARBON DIOXIDE AND OTHER GREENHOUSE GAS EMISSION OFFSETS; COMPUTER SOFTWARE FOR USE IN DETERMINING ENERGY CONSUMPTION AND PEAK DEMAND SAVINGS; SOFTWARE FOR CONTROLLING BUILDING ENVIRONMENT, ACCESS AND SECURITY SYSTEMS (U.S. CLS. 21, 23, 26, 36 AND 38).

CLASS 35—ADVERTISING AND BUSINESS

FOR CUSTOMER SERVICE MANAGEMENT FOR OTHERS RELATING TO BUILDING ENVIRONMENT MANAGEMENT AND ENERGY USAGE; ENERGY USAGE MANAGEMENT AND CONSULTING SERVICES IN THE FIELD OF ENVIRONMENTAL EMISSIONS MANAGEMENT, NAMELY, ADVISING BUSINESSES AND INDIVIDUALS ON ISSUES OF MANAGING EMISSIONS FOR BUSINESS PURPOSES (U.S. CLS. 100, 101 AND 102).

CLASS 37—CONSTRUCTION AND REPAIR

FOR MAINTENANCE AND REPAIR OF HEATING, VENTILATING, REFRIGERATING, AIR-CONDITIONING AND LIGHTING APPARATUSES AND ACCESS AND SECURITY SYSTEMS (U.S. CLS. 100, 103 AND 106).

CLASS 41—EDUCATION AND ENTERTAINMENT

FOR TRAINING IN THE FIELD OF HOW TO USE BUILDING MANAGEMENT SOFTWARE RELATING TO BUILDING ENVIRONMENT AND EMERY USAGE (U.S. CLS. 100, 101 AND 107).

CLASS 42—SCIENTIFIC AND COMPUTER SERVICES

FOR MAINTENANCE AND REPAIR OF COMPUTER SOFTWARE (U.S. CLS. 100 AND 101).

LAURIE MAYES, EXAMINING ATTORNEY

SN 85-436,322. WAUKESHA-PEARCE INDUSTRIES, INC., HOUSTON, TX. FILED 9-30-2011.

POWERED BY SOLUTIONS

THE MARK CONSISTS OF STANDARD CHARACTERS WITHOUT CLAIM TO ANY PARTICULAR FONT, STYLE, SIZE, OR COLOR.

CLASS 7—MACHINERY

FOR GAS AND DIESEL ENGINES NOT FOR LAND VEHICLES, AIR COMPRESSORS, HYDRAULIC PUMPS AND PACKAGED ENGINE UNITS COMPRISED OF ENGINE-DRIVEN COMPRESSORS FOR MACHINES, ENGINE-DRIVEN HYDRAULIC PUMPS AND ENGINE-DRIVEN BLOWERS; ELECTRIC GENERATORS AND ENGINE-DRIVEN ELECTRIC GENERATORS, GAS AND DIESEL INDUSTRIAL ENGINES, COMPRESSORS FOR REFRIGERATION AND AIR-CONDITIONERS, FLUID PUMP FOR MACHINES, AND PACKAGED ENGINE UNITS, COMPRISING ENGINE-DRIVEN COMPRESSORS FOR MACHINES, HYDRAULIC PUMPS, AND POWER OPERATED BLOWERS ALL FOR INDUSTRIAL USE; CATALYTIC CONVERTERS FOR TREATING EXHAUST GASES (U.S. CLS. 13, 19, 21, 23, 31, 34 AND 35).

CLASS 35—ADVERTISING AND BUSINESS

FOR DISTRIBUTORSHIP SERVICES IN THE FIELD OF ENGINES, PACKAGED ENGINE UNITS COMPRISING ENGINE-DRIVEN COMPRESSORS, BLOWERS, GENERATORS AND PUMPS, TRUCK EXCAVATORS, MATERIAL PROCESSORS, DEMOLITION TOOLS, BREAKERS, DEBRIS HANDLING AND GROUNDS MAINTENANCE EQUIPMENT, TILLER/CULTIVATORS, MOWERS, TRUCK LOADERS, COMPACTION EQUIPMENT, OFF-ROAD DUMP TRUCKS, OFF-ROAD WATER TRUCKS, DOZERS, EXCAVATORS AND ATTACHMENTS, GRAPPLERS, PAVING EQUIPMENT, SOIL STABILIZERS AND ASPHALT RECLAIMING EQUIPMENT, PROCESSORS, SHEARS, HYDRAULIC BREAKERS, MINI HYDRAULIC EXCAVATORS, MOTOR GRADERS, TELESCOPIC BOOM EXCAVATORS, TRUCK MOUNTED EXCAVATORS, TRUCK MOUNTED STREET AND DRAINAGE CLEANING EQUIPMENT, WHEEL LOADERS, DEMOLITION EQUIPMENT, SCRAP AND TIMBER HANDLING EQUIPMENT, AND BULK HANDLING EQUIPMENT (U.S. CLS. 100, 101 AND 102).

CLASS 36—INSURANCE AND FINANCIAL

FOR EQUIPMENT FINANCING SERVICES (U.S. CLS. 100, 101 AND 102).

CLASS 37—CONSTRUCTION AND REPAIR

FOR MAINTENANCE AND REPAIR OF PACKAGED ENGINE UNITS COMPRISED OF ENGINE-DRIVEN COMPRESSORS, GENERATORS, BLOWERS, AND PUMPS; MAINTENANCE, REPAIR AND RENTAL OF CONSTRUCTION EQUIPMENT, NAMELY, COMPACTION EQUIPMENT, CRANES, CRAWLER DOZERS, EXCAVATORS AND ATTACHMENTS, GRAPPLERS, PAVING EQUIPMENT, SOIL STABILIZERS AND ASPHALT RECLAIMING EQUIPMENT, PROCESSORS, SHEARS, HYDRAULIC BREAKERS, LIGHT CONSTRUCTION EQUIPMENT, BACKHOE LOADERS, MINI HYDRAULIC EXCAVATORS, SKID STEER LOADERS, MOTOR GRADERS, TELESCOPIC BOOM EXCAVATORS, TRUCK MOUNTED EXCAVATORS, TRUCK MOUNTED STREET AND DRAINAGE CLEANING EQUIPMENT, WHEEL LOADERS, DEMOLITION EQUIPMENT, SCRAP AND TIMBER HANDLING EQUIPMENT, AND BULK HANDLING EQUIPMENT (U.S. CLS. 100, 103 AND 106).

CLASS 39—TRANSPORTATION AND STORAGE

FOR RENTAL OF OFF-ROAD DUMP TRUCKS AND OFF-ROAD WATER TRUCKS (U.S. CLS. 100 AND 105).

ROBERT STRUCK, EXAMINING ATTORNEY

SN 85-436,466. ENDOCARE, INC., CHADDS FORD, PA.
FILED 9-30-2011.



THE MARK CONSISTS OF A STYLIZED GRAPHIC OF A LOWER CASE "E" WITH A CURVED LINE MAKING UP A PORTION OF THE "E" AND EXTENDING BEYOND THE "E".

CLASS 10—MEDICAL APPARATUS

FOR MEDICAL DEVICES AND INSTRUMENTS FOR USE IN SURGICAL APPLICATIONS, NAMELY, CRYOSURGICAL SYSTEMS, CRYOSURGICAL PROBES, AND UROLOGICAL STENT DEVICES (U.S. CLS. 26, 39 AND 44).

FIRST USE 1-0-2003; IN COMMERCE 1-0-2003.

CLASS 41—EDUCATION AND ENTERTAINMENT

FOR EDUCATIONAL SERVICES, NAMELY, CONDUCTING CLASSES, SEMINARS, CONFERENCES AND WORKSHOPS IN THE FIELD OF MEDICAL AND SURGICAL DEVICES AND TECHNIQUES; PROVIDING CONTINUING EDUCATION COURSES, NAMELY, TRAINING AND EDUCATIONAL SERVICES IN THE FIELD OF MEDICAL AND SURGICAL DEVICES AND TECHNIQUES (U.S. CLS. 100, 101 AND 107).

FIRST USE 1-0-2003; IN COMMERCE 1-0-2003.

CLASS 44—MEDICAL, BEAUTY AND AGRICULTURAL SERVICES

FOR PROVIDING ONLINE MEDICAL INFORMATION ON THE SUBJECT OF PHARMACEUTICALS AND HEALTHCARE (U.S. CLS. 100 AND 101).

FIRST USE 1-0-2003; IN COMMERCE 1-0-2003.
NAKIA HENRY, EXAMINING ATTORNEY

SN 85-436,935. HELIX STUDIOS, INC, SAN DIEGO, CA.
FILED 9-30-2011.

HELIXSTUDIOS

THE MARK CONSISTS OF THE STYLIZED WORDING "HELIXSTUDIOS".

CLASS 9—ELECTRICAL AND SCIENTIFIC APPARATUS

FOR DVDS FEATURING ADULT-THEMED VIDEOS (U.S. CLS. 21, 23, 26, 36 AND 38).

FIRST USE 9-1-2003; IN COMMERCE 9-1-2003.

CLASS 38—COMMUNICATION

FOR STREAMING OF AUDIO, VISUAL AND AUDIO-VISUAL MATERIAL VIA A GLOBAL COMPUTER NETWORK (U.S. CLS. 100, 101 AND 104).

FIRST USE 9-1-2003; IN COMMERCE 9-1-2003.
MEGHAN REINHART, EXAMINING ATTORNEY

SN 85-437,315. RESOURCE COMPLIANCE TECHNOLOGIES, INC., MOBILE, AL. FILED 10-2-2011.



NO CLAIM IS MADE TO THE EXCLUSIVE RIGHT TO USE "GREEN", APART FROM THE MARK AS SHOWN.

THE COLOR(S) GREEN AND WHITE IS/ARE CLAIMED AS A FEATURE OF THE MARK.

THE MARK CONSISTS OF THE STYLIZED WORDS "NATURE'S GREEN". THE TERM "NATURE'S" APPEARS IN GREEN ABOVE THREE GREEN ARROWS DRAWN TO LOOK LIKE LEAVES WHICH ARE FORMING A CIRCLE. A WHITE LINE APPEARS THROUGH THE MIDDLE OF EACH LEAF. THE TERM "GREEN" APPEARS BELOW THE THREE GREEN ARROWS.

CLASS 2—PAINTS

FOR PAINTS, VARNISHES, LACQUERS; PRESERVATIVES AGAINST RUST IN THE NATURE OF COATINGS AND PRESERVATIVES AGAINST DETERIORATION OF WOOD; COLORANTS; MORDANT DYES; RAW NATURAL RESINS; METALS IN FOIL AND POWDER FORM FOR PAINTERS, DECORATORS, PRINTERS AND ARTISTS; CONCRETE SEALERS IN THE FORM OF A COATING (U.S. CLS. 6, 11 AND 16).

FIRST USE 1-0-2011; IN COMMERCE 1-0-2011.

CLASS 3—COSMETICS AND CLEANING PREPARATIONS

FOR BLEACHING PREPARATIONS FOR LAUNDRY USE; SUBSTANCES FOR LAUNDRY USE, NAMELY, DETERGENTS; CLEANING, POLISHING, SCOURING AND ABRASIVE PREPARATIONS; SOAPS; PERFUMERY, ESSENTIAL OILS, COSMETICS, HAIR LOTIONS; DENTIFRICES; CLEANING PREPARATIONS; GLASS CLEANERS (U.S. CLS. 1, 4, 6, 50, 51 AND 52).

FIRST USE 1-0-2011; IN COMMERCE 1-0-2011.
THOMAS MANOR, EXAMINING ATTORNEY

SN 85-437,405. MONTEVERDI, ERIKA M., REDWOOD CITY, CA. FILED 10-3-2011.

SN 85-437,661. RB MILESTONE GROUP, LLC, NEW YORK, NY. FILED 10-3-2011.

BabyCucina

HiAlpha

THE MARK CONSISTS OF STANDARD CHARACTERS WITHOUT CLAIM TO ANY PARTICULAR FONT, STYLE, SIZE, OR COLOR.

THE ENGLISH TRANSLATION OF "CUCINA" IN THE MARK IS "KITCHEN".

CLASS 5—PHARMACEUTICALS

FOR BABY FOODS (U.S. CLS. 6, 18, 44, 46, 51 AND 52).

CLASS 16—PAPER GOODS AND PRINTED MATTER

FOR RECIPE BOOKS (U.S. CLS. 2, 5, 22, 23, 29, 37, 38 AND 50).

JORDAN BAKER, EXAMINING ATTORNEY

THE MARK CONSISTS OF STANDARD CHARACTERS WITHOUT CLAIM TO ANY PARTICULAR FONT, STYLE, SIZE, OR COLOR.

CLASS 35—ADVERTISING AND BUSINESS

FOR ORGANIZING CONFERENCES IN THE FIELD OF INVESTMENT, FOR BUSINESS PURPOSES (U.S. CLS. 100, 101 AND 102).

FIRST USE 11-26-2011; IN COMMERCE 11-26-2011.

CLASS 45—PERSONAL AND LEGAL SERVICES

FOR ONLINE SOCIAL NETWORK FOR INVESTMENT PROFESSIONALS (U.S. CLS. 100 AND 101).

FIRST USE 10-25-2011; IN COMMERCE 10-25-2011.

ZACHARY BELLO, EXAMINING ATTORNEY

SN 85-437,444. DECLAIRE, JEFFREY M.D., ROCHESTER HILLS, MI. FILED 10-3-2011.

SN 85-437,950. MENASHA CORPORATION, NEENAH, WI. FILED 10-3-2011.

MOVESTRONG

RETAIL INTEGRATION INSTITUTE

THE MARK CONSISTS OF STANDARD CHARACTERS WITHOUT CLAIM TO ANY PARTICULAR FONT, STYLE, SIZE, OR COLOR.

CLASS 16—PAPER GOODS AND PRINTED MATTER

FOR A SERIES OF BOOKS, WRITTEN ARTICLES, HANDOUTS AND WORKSHEETS IN THE FIELD OF HEALTH; EDUCATIONAL KITS SOLD AS A UNIT IN THE FIELD OF FITNESS CONSISTING PRIMARILY OF WORKSHEETS, BOOKS, PICTURES, FITNESS EQUIPMENT AND ALSO INCLUDING DVDS (U.S. CLS. 2, 5, 22, 23, 29, 37, 38 AND 50).

CLASS 25—CLOTHING

FOR ATHLETIC APPAREL, NAMELY, SHIRTS, PANTS, JACKETS, FOOTWEAR, HATS AND CAPS, ATHLETIC UNIFORMS (U.S. CLS. 22 AND 39).

CLASS 28—TOYS AND SPORTING GOODS

FOR PHYSICAL FITNESS EQUIPMENT, NAMELY, YOGA MATS, RESISTANT BANDS, EXERCISE TUBING (U.S. CLS. 22, 23, 38 AND 50).

MICHELE SWAIN, EXAMINING ATTORNEY

THE MARK CONSISTS OF STANDARD CHARACTERS WITHOUT CLAIM TO ANY PARTICULAR FONT, STYLE, SIZE, OR COLOR.

OWNER OF U.S. REG. NO. 3,008,078.

SEC. 2(F).

CLASS 35—ADVERTISING AND BUSINESS

FOR BUSINESS CONSULTATION SERVICES FOR RETAILING COMPANIES IN THE AREAS OF PRODUCT DEMAND, MARKETING, MANUFACTURING, PURCHASING, DISTRIBUTION, PACKAGING, TRANSPORTATION AND LOGISTICS; AND STATISTICAL ANALYSIS AND FINANCIAL STATEMENT ANALYSIS RENDERED IN CONNECTION THEREWITH; PROMOTING THE SALE OF GOODS OF OTHERS THROUGH THE CREATION, ASSEMBLY, AND DISTRIBUTION OF PROMOTIONAL DISPLAYS AND PROMOTIONAL MATERIALS (U.S. CLS. 100, 101 AND 102).

FIRST USE 7-10-2004; IN COMMERCE 7-10-2004.

CLASS 39—TRANSPORTATION AND STORAGE

FOR PACKAGING ARTICLES TO THE ORDER AND SPECIFICATION OF OTHERS (U.S. CLS. 100 AND 105).

FIRST USE 7-10-2004; IN COMMERCE 7-10-2004.

MATTHEW EINSTEIN, EXAMINING ATTORNEY

SN 85-438,554. WEAR SAFE (M) SDN BHD, SELANGOR DARUL EHSAN, MALAYSIA, FILED 10-4-2011.

SN 85-438,680. INNOVATIVE HEALTH SERVICES OF AMERICA, INC., BUFFALO, NY. FILED 10-4-2011.

INTOUCH ASSURE

THE MARK CONSISTS OF STANDARD CHARACTERS WITHOUT CLAIM TO ANY PARTICULAR FONT, STYLE, SIZE, OR COLOR.

CLASS 9—ELECTRICAL AND SCIENTIFIC APPARATUS

FOR PROTECTIVE FACE MASKS NOT FOR MEDICAL PURPOSES; PROTECTING FACE MASKS FOR LABORATORY USE (U.S. CLS. 21, 23, 26, 36 AND 38).

CLASS 10—MEDICAL APPARATUS

FOR HAND HYGIENE PRODUCTS, NAMELY, MEDICAL GLOVES FOR PROTECTIVE PURPOSES; SURGICAL FACE MASKS; SANITARY FACE MASKS FOR MEDICAL PURPOSES; FACE MASKS FOR USE BY HEALTH CARE PROVIDERS IN THE HEALTHCARE INDUSTRY (U.S. CLS. 26, 39 AND 44).

FIRST USE 5-9-2011; IN COMMERCE 5-9-2011.

COURTNEY ALVAREZ, EXAMINING ATTORNEY

SN 85-438,676. THE FUNDING FARM, BRANDON, SD. FILED 10-4-2011.

THE FUNDING FARM

THE MARK CONSISTS OF STANDARD CHARACTERS WITHOUT CLAIM TO ANY PARTICULAR FONT, STYLE, SIZE, OR COLOR.

NO CLAIM IS MADE TO THE EXCLUSIVE RIGHT TO USE "FUNDING", APART FROM THE MARK AS SHOWN.

CLASS 35—ADVERTISING AND BUSINESS

FOR BUSINESS PLANNING; MANAGEMENT CONSULTING AND ADVISORY SERVICES IN THE AREA OF CORPORATE GROWTH STRATEGY; BUSINESS SERVICES, NAMELY, MATCHING POTENTIAL PRIVATE INVESTORS WITH ENTREPRENEURS NEEDING FUNDING (U.S. CLS. 100, 101 AND 102).

FIRST USE 9-1-2011; IN COMMERCE 9-1-2011.

CLASS 36—INSURANCE AND FINANCIAL

FOR VENTURE CAPITAL FUNDING SERVICES TO EMERGING AND START-UP COMPANIES (U.S. CLS. 100, 101 AND 102).

FIRST USE 9-1-2011; IN COMMERCE 9-1-2011.

BARNEY CHARLON, EXAMINING ATTORNEY



INNOVATIVE HEALTH
SERVICES OF AMERICA

NO CLAIM IS MADE TO THE EXCLUSIVE RIGHT TO USE "HEALTH SERVICES OF AMERICA", APART FROM THE MARK AS SHOWN.

THE COLOR(S) GREEN, RED AND WHITE IS/ARE CLAIMED AS A FEATURE OF THE MARK.

THE MARK CONSISTS OF TWO PERPENDICULAR GREEN ADHESIVE BANDAGES CROSSING EACH OTHER AT THE CENTER, SITUATED WITHIN A DARKER GREEN CIRCLE WITH WHITE INTERIOR, WHICH ITSELF IS SITUATED IMMEDIATELY ABOVE THE WORDS "INNOVATIVE HEALTH SERVICES OF AMERICA" COLORED RED.

CLASS 35—ADVERTISING AND BUSINESS

FOR RETAIL PHARMACY SERVICES; BUSINESS MANAGEMENT AND CONSULTING SERVICES FOR THE HEALTH CARE INDUSTRY, NAMELY, CUSTOMER SERVICE, ACCOUNTING SERVICES, PROCEDURE CODING SERVICES, BILLING SERVICES, HUMAN RESOURCE ADMINISTRATIVE SERVICES AND MARKETING SERVICES (U.S. CLS. 100, 101 AND 102).

CLASS 44—MEDICAL, BEAUTY AND AGRICULTURAL SERVICES

FOR URGENT MEDICAL CARE CENTERS; HOME HEALTH CARE SERVICES (U.S. CLS. 100 AND 101).

SKYE YOUNG, EXAMINING ATTORNEY

SN 85-438,772. PANLINE U.S.A. INC., NORTHVALE, NJ. FILED 10-4-2011.

MIX & MAKEUP

THE MARK CONSISTS OF STANDARD CHARACTERS WITHOUT CLAIM TO ANY PARTICULAR FONT, STYLE, SIZE, OR COLOR.

NO CLAIM IS MADE TO THE EXCLUSIVE RIGHT TO USE "MAKEUP", APART FROM THE MARK AS SHOWN.

CLASS 3—COSMETICS AND CLEANING PREPARATIONS

FOR COSMETICS AND NON-MEDICATED SKIN CARE PREPARATIONS FOR GIRLS; NAIL POLISH (U.S. CLS. 1, 4, 6, 50, 51 AND 52).

CLASS 8—HAND TOOLS

FOR MANICURE AND PEDICURE SETS FOR GIRLS (U.S. CLS. 23, 28 AND 44).

CLASS 28—TOYS AND SPORTING GOODS

FOR DO-IT-YOURSELF HOBBY CRAFT KIT FOR MAKING CHILDREN'S PLAY COSMETICS AND CHILDREN'S PLAY BEAUTY CARE GOODS (U.S. CLS. 22, 23, 38 AND 50).

AMY KERTGATE, EXAMINING ATTORNEY

SN 85-439,041. SINHA, DIPESH, NEW YORK, NY. FILED 10-4-2011.

Inky Jack

THE MARK CONSISTS OF STANDARD CHARACTERS WITHOUT CLAIM TO ANY PARTICULAR FONT, STYLE, SIZE, OR COLOR.

CLASS 9—ELECTRICAL AND SCIENTIFIC APPARATUS

FOR AUDIO AND VIDEO RECORDINGS FEATURING MUSIC AND ARTISTIC PERFORMANCES; DOWNLOADABLE MUSICAL SOUND RECORDINGS (U.S. CLS. 21, 23, 26, 36 AND 38).

FIRST USE 9-10-2010; IN COMMERCE 9-29-2011.

CLASS 25—CLOTHING

FOR HOODED SWEAT SHIRTS; SHIRTS AND SHORT-SLEEVED SHIRTS (U.S. CLS. 22 AND 39).

FIRST USE 9-10-2010; IN COMMERCE 9-29-2011.

CLASS 41—EDUCATION AND ENTERTAINMENT

FOR COMPOSITION OF MUSIC FOR OTHERS; ENTERTAINMENT IN THE NATURE OF VISUAL AND AUDIO PERFORMANCES BY A MUSICAL BAND; ENTERTAINMENT SERVICES BY A MUSICAL ARTIST AND PRODUCER, NAMELY, MUSICAL COMPOSITION FOR OTHERS AND PRODUCTION OF MUSICAL SOUND RECORDINGS; ENTERTAINMENT, NAMELY, LIVE MUSIC CONCERTS; PRODUCTION OF MUSICAL SOUND RECORDING; PRODUCTION OF SOUND AND MUSIC VIDEO RECORDINGS (U.S. CLS. 100, 101 AND 107).

FIRST USE 9-10-2010; IN COMMERCE 9-29-2011.
GENE MACIOL, EXAMINING ATTORNEY

SN 85-438,805. GANDAYA LIMITADA, SANTIAGO, CHILE, FILED 10-4-2011.



THE MARK CONSISTS OF A DRAWING OF A PERSON WITH LONG HAIR. THE WORD "GANDAYA" TO THE RIGHT OF THE PERSON WITH A DRAWING OF TWO LEAVES APPEARING AT THE END OF "GANDAYA".

THE ENGLISH TRANSLATION OF THE WORD "GANDAYA" IN THE MARK IS "CAREFREE LIFESTYLE".

CLASS 9—ELECTRICAL AND SCIENTIFIC APPARATUS

FOR ANTI-GLARE GLASSES; CASES FOR EYEGLASSES AND SUNGLASSES; EYEGLASS CHAINS AND CORDS; EYEGLASS FRAMES; GOGGLES FOR SPORTS; HEADPHONES; LOUDSPEAKERS; PERSONAL STEREOS; PROTECTIVE HELMETS; PROTECTIVE HELMETS FOR SPORTS; RIDING HELMETS; SAFETY HELMETS; SPECTACLE CASES; SPECTACLE FRAMES; SPECTACLE GLASSES; SUNGLASS CHAINS AND CORDS; SUNGLASSES; SURVEYORS' LEVELS (U.S. CLS. 21, 23, 26, 36 AND 38).

CLASS 18—LEATHER GOODS

FOR BACKPACKS; BAGS FOR CLIMBERS IN THE NATURE OF ALL-PURPOSE CARRYING BAGS; BAGS FOR SPORTS; BEACH BAGS; HANDBAGS; POCKET WALLETS; SCHOOL BAGS; SCHOOL SATCHELS; SUITCASES; TRAVELING BAGS (U.S. CLS. 1, 2, 3, 22 AND 41).

CLASS 25—CLOTHING

FOR BALACLAVAS; BATHING SUITS; BEACHWEAR; BELTS; BIKINIS; BOOTS; CAPS; CLOTHING OF LEATHER AND OF IMITATIONS OF LEATHER, NAMELY, COATS, JACKETS, STUFF JACKETS, VESTS, SHIRTS, BELTS, MONEY BELTS, GLOVES, MITTENS, TROUSERS, PANTS, SHORTS, DRESSES, SKIRTS, CAPS AND HATS; COATS; DRESSES; EAR MUFFS; FOOTWEAR; GLOVES; HATS; HEADBANDS; HOSIERY; JACKETS; JERSEYS; MITTENS; MONEY BELTS; NECKERCHIEFS; OVERCOATS; PARKAS; POCKET SQUARES; PULLOVERS; RAIN COATS; SHIRT FRONTS; SHIRT YOKES; SHIRTS; SHORTS; SINGLETTS; SKIRTS; SLIPPERS; SOCKS; STUFF JACKETS; SWEATERS; SWEATSHIRTS; SWIM SUITS; T-SHIRTS; TIGHTS; TROUSERS; UNDERWEAR; VESTS; VISORS (U.S. CLS. 22 AND 39).

GENE MACIOL, EXAMINING ATTORNEY

SN 85-439,547. R.J. DUNHAM & COMPANY, INC., PLANO, TX. FILED 10-5-2011.



NO CLAIM IS MADE TO THE EXCLUSIVE RIGHT TO USE "BOOKS", APART FROM THE MARK AS SHOWN.

THE MARK CONSISTS OF THE WORDS "DUNHAM BOOKS." THE WORD "DUNHAM" APPEARS IN THICK, SANS SERIF TYPEFACE; THE WORD "BOOKS" APPEARS IN SMALLER, THINNER ITALICIZED TYPE, WHICH IS RIGHT-JUSTIFIED BELOW THE WORD "DUNHAM." A CAPITAL LETTER "D" IS CENTERED ON THE LETTERS "U" AND "H" IN "DUNHAM" AND APPEARS ABOVE THE WORD "DUNHAM." THE LETTER "D" APPEARS IN A STYLIZED SANS SERIF TYPEFACE, AND IS ANGLED UP TO THE RIGHT. THE LETTER "D" FORMS A BOOK: THE VERTICAL LINE IN THE "D" IS THE SPINE OF THE BOOK, AND THE CURVED LINE IN THE "D" FORMS AN OUTLINE OF THE PAGES IN THE BOOK, AS IF VIEWED FROM ABOVE.

CLASS 16—PAPER GOODS AND PRINTED MATTER

FOR BOOKS ON A VARIETY OF TOPICS (U.S. CLS. 2, 5, 22, 23, 29, 37, 38 AND 50).
FIRST USE 7-1-2006; IN COMMERCE 7-1-2006.

CLASS 41—EDUCATION AND ENTERTAINMENT

FOR BOOK PUBLISHING (U.S. CLS. 100, 101 AND 107).
FIRST USE 7-1-2006; IN COMMERCE 7-1-2006.
ROBERT STRUCK, EXAMINING ATTORNEY

SN 85-439,593. PRESIDENT AND FELLOWS OF HARVARD COLLEGE, CAMBRIDGE, MA. FILED 10-5-2011.



OWNER OF U.S. REG. NOS. 1,605,026, 2,112,010 AND OTHERS.

THE MARK CONSISTS OF A SHIELD SHAPED DESIGN WITH AN UPPERMOST FIELD CONTAINING THE LETTERS "VE RI TAS" WITHIN A SERIES OF THREE OPEN BOOK SHAPED DEVICES. IN THE LOWER FIELD OF THE DESIGN CONSISTS THREE FIVE-PETALED LEAVES, TWO OF WHICH ARE POSITIONED IN THE UPPER RIGHT-HAND CORNER, AND ONE OF WHICH IS POSITIONED IN THE LOWER LEFT-HAND CORNER, WITH A STEPPED LINE CUTTING ACROSS THE SHIELD DIAGONALLY.

"VERITAS" TRANSLATED INTO ENGLISH MEANS "TRUTH."

CLASS 25—CLOTHING

FOR CLOTHING, NAMELY, T-SHIRTS, SWEAT-SHIRTS, HATS, VESTS, INFANT ONE PIECE CLOTHING (U.S. CLS. 22 AND 39).

FIRST USE 0-0-1994; IN COMMERCE 0-0-1994.

CLASS 41—EDUCATION AND ENTERTAINMENT

FOR EDUCATIONAL SERVICES, NAMELY, PROVIDING COURSES OF INSTRUCTION AND TRAINING AT THE UNIVERSITY LEVEL IN THE FIELD OF EDUCATION (U.S. CLS. 100, 101 AND 107).

FIRST USE 0-0-1937; IN COMMERCE 0-0-1937.

PAUL E. FAHRENKOPF, EXAMINING ATTORNEY

SN 85-439,649. SWENDELL LLC, DBA DEERDUMMY.COM, MAPLE LAKE, MN. FILED 10-5-2011.



NO CLAIM IS MADE TO THE EXCLUSIVE RIGHT TO USE "DEER", APART FROM THE MARK AS SHOWN.

THE STIPPLING IS FOR SHADING PURPOSES ONLY.
THE MARK CONSISTS OF THE WORDING "DEER DUMMY" ALONG WITH A MOUNTED DEER BUCK AND A BUTCHER KNIFE.

CLASS 8—HAND TOOLS

FOR BUTCHER KNIVES (U.S. CLS. 23, 28 AND 44).
FIRST USE 6-13-2011; IN COMMERCE 6-13-2011.

CLASS 30—STAPLE FOODS

FOR FOOD SEASONINGS (U.S. CL. 46).
FIRST USE 6-13-2011; IN COMMERCE 6-13-2011.
ADA HAN, EXAMINING ATTORNEY

SN 85-439,767. LITTLE AMERICAN BUSINESSES, INC., COSTA MESA, CA. FILED 10-5-2011.

SEED PEOPLE'S MARKET

THE MARK CONSISTS OF STANDARD CHARACTERS WITHOUT CLAIM TO ANY PARTICULAR FONT, STYLE, SIZE, OR COLOR.

OWNER OF U.S. REG. NO. 3,724,954.

NO CLAIM IS MADE TO THE EXCLUSIVE RIGHT TO USE "MARKET", APART FROM THE MARK AS SHOWN.

CLASS 35—ADVERTISING AND BUSINESS

FOR RETAIL STORES FEATURING SPECIALTY PRODUCTS, NAMELY, FOODS AND BEVERAGES, GROCERIES, FINE ART, ARTISAN CRAFTS, BOOKS, FURNITURE, HOUSEWARES, APPAREL AND ACCESSORIES, ART SUPPLIES, LOTIONS AND SOAPS, JEWELRY AND BEADS, AND ENVIRONMENTALLY SUSTAINABLE PRODUCTS, NAMELY, FOODS AND BEVERAGES, FURNITURE, HOUSEWARES, FABRICS, APPAREL AND ACCESSORIES, AND LOTIONS AND SOAPS; RETAIL STORE AND RETAIL OUTLET SERVICES, NAMELY, BUSINESS MANAGEMENT OF RETAIL STORES FOR OTHERS AND ADVERTISING AND MARKETING FOR RETAIL STORES (U.S. CLS. 100, 101 AND 102).

FIRST USE 3-20-2009; IN COMMERCE 3-20-2009.

CLASS 36—INSURANCE AND FINANCIAL

FOR LEASING OF RETAIL STORE SPACE; FINANCIAL MANAGEMENT OF RETAIL STORES FOR OTHERS (U.S. CLS. 100, 101 AND 102).

FIRST USE 3-20-2009; IN COMMERCE 3-20-2009.

MICHELE SWAIN, EXAMINING ATTORNEY

SN 85-441,295. HU-FRIEDY MFG. CO., LLC, CHICAGO, IL.
FILED 10-6-2011.

HOW THE BEST PERFORM

THE MARK CONSISTS OF STANDARD CHARACTERS WITHOUT CLAIM TO ANY PARTICULAR FONT, STYLE, SIZE, OR COLOR.

CLASS 3—COSMETICS AND CLEANING PREPARATIONS

FOR DENTAL INSTRUMENT CLEANING SOLUTIONS AND SOAKING SOLUTIONS, POWDERS, AND POWDER PACKETS FOR CLEANING PURPOSES (U.S. CLS. 1, 4, 6, 50, 51 AND 52).

CLASS 4—LUBRICANTS AND FUELS

FOR DENTAL INSTRUMENT LUBRICATING OILS (U.S. CLS. 1, 6 AND 15).

CLASS 10—MEDICAL APPARATUS

FOR DENTAL, ENDODONTIC, PERIODONTAL AND ORTHODONTIC INSTRUMENTS AND ACCESSORIES FOR USE THEREWITH, NAMELY HAND-HELD CURTTES, FORCEPS, BURNISHERS, CARVERS, ELEVATORS, PLUGGERS, SPREADERS, EXCAVATORS, SCALERS, PROBES, EXPLORERS, MIRRORS, RON-GEURS, SCISSORS, DRESSING PLIERS, ULTRASONIC SCALER INSERTS AND CASSETTES (U.S. CLS. 26, 39 AND 44).

CLASS 35—ADVERTISING AND BUSINESS

FOR ONLINE RETAIL STORE SERVICES AND RETAIL SERVICES BY DIRECT SOLICITATION BY SALES AGENTS, ALL FEATURING DENTAL, ENDODONTIC, PERIODONTAL, AND ORTHODONTIC INSTRUMENTS AND ACCESSORIES FOR USE THEREWITH (U.S. CLS. 100, 101 AND 102).

ALEX KEAM, EXAMINING ATTORNEY

SN 85-441,644. SYLVIA MILLER, JERSEY CITY, NJ. FILED 10-7-2011.

ASTROLOGY FROM THE STARS

THE MARK CONSISTS OF STANDARD CHARACTERS WITHOUT CLAIM TO ANY PARTICULAR FONT, STYLE, SIZE, OR COLOR.

CLASS 28—TOYS AND SPORTING GOODS

FOR BOARD GAMES (U.S. CLS. 22, 23, 38 AND 50).

CLASS 41—EDUCATION AND ENTERTAINMENT

FOR ENTERTAINMENT SERVICES, NAMELY, PROVIDING ON-LINE COMPUTER GAMES (U.S. CLS. 100, 101 AND 107).

VIVIAN MICZNIK FIRST, EXAMINING ATTORNEY

SN 85-441,726. FILTER-ALL, INC., MAGNOLIA, TX. FILED 10-7-2011.



THE MARK CONSISTS OF A DROP OF LIQUID PASSING THROUGH THE BODY OF A SQUARE OF MATERIAL WHEREIN THE LIQUID IS MORE DARKLY SHADED ABOVE THE SQUARE OF MATERIAL IN RELATION TO THE SHADING BELOW THE SQUARE OF MATERIAL.

CLASS 11—ENVIRONMENTAL CONTROL APPARATUS

FOR AIR FILTERS FOR INDUSTRIAL INSTALLATIONS; FIBROUS FILTERING MEDIA FOR GENERAL INDUSTRIAL USE IN THE PURIFICATION OF AIR AND INDUSTRIAL FLUIDS; FILTERING UNITS FOR SEPARATION OF LIQUIDS FOR INDUSTRIAL USE; FILTERS FOR AIR CONDITIONING; FILTERS MADE OF FIBER FOR WATER FILTRATION; FILTRATION UNITS FOR FILTERING AND TREATING COOKING OIL BEING PART OF COMMERCIAL DEEP FRYERS, AND PARTS THEREFOR; FILTERS FOR EDIBLE OILS AND SHORTENING FOR USE IN THE COMMERCIAL FOOD INDUSTRY; AND WATER FILTERS (U.S. CLS. 13, 21, 23, 31 AND 34).

FIRST USE 6-22-1994; IN COMMERCE 6-22-1994.

CLASS 35—ADVERTISING AND BUSINESS

FOR RETAIL AND WHOLESALE STORE SERVICES IN THE FIELD OF FILTERING; AND RETAIL AND WHOLESALE STORE SERVICES THROUGH DIRECT SOLICITATION BY DISTRIBUTORS DIRECTED TO END-USERS IN THE FIELD OF FILTERING (U.S. CLS. 100, 101 AND 102).

FIRST USE 6-22-1994; IN COMMERCE 6-22-1994.
FRANK LATTUCA, EXAMINING ATTORNEY

SN 85-441,729. WESTLAKE REED LESKOSKY, LTD., CLEVELAND, OH. FILED 10-7-2011.

RECOOL

THE MARK CONSISTS OF STANDARD CHARACTERS WITHOUT CLAIM TO ANY PARTICULAR FONT, STYLE, SIZE, OR COLOR.

CLASS 35—ADVERTISING AND BUSINESS

FOR ADVERTISING SERVICES, NAMELY, DISSEMINATION OF ARCHITECTURAL, ENGINEERING AND CONSTRUCTION PRODUCTS ADVERTISING FOR OTHERS VIA AN ON-LINE ELECTRONIC COMMUNICATIONS NETWORK; PROVIDING INFORMATION AND ADVICE TO CONSUMERS REGARDING THE SELECTION FOR PURCHASE OF ARCHITECTURAL, ENGINEERING AND CONSTRUCTION PRODUCTS AND SERVICES; COMPUTERIZED ON-LINE RETAIL STORE SERVICES FEATURING ARCHITECTURAL, ENGINEERING AND CONSTRUCTION PRODUCTS AND SERVICES (U.S. CLS. 100, 101 AND 102).

CLASS 38—COMMUNICATION

FOR PROVIDING ONLINE FACILITIES FOR REAL-TIME INTERACTION WITH OTHER COMPUTER USERS AND ELECTRONIC TRANSMISSION OF MESSAGES AMONG COMPUTER USERS IN THE ARCHITECTURAL, ENGINEERING AND CONSTRUCTION FIELDS; PROVIDING ONLINE VIDEO AND AUDIO BROADCASTING IN THE FIELDS OF ARCHITECTURAL, ENGINEERING AND CONSTRUCTION (U.S. CLS. 100, 101 AND 104).

CLASS 41—EDUCATION AND ENTERTAINMENT

FOR PROVIDING EDITORIAL CONTENT TO CONSUMERS IN THE FIELDS OF ARCHITECTURAL, ENGINEERING AND CONSTRUCTION, NAMELY, PROVIDING ONLINE PUBLICATIONS IN THE NATURE OF ARTICLES AND NEWSLETTERS CONTAINING EDITORIAL REPORTING ON ARCHITECTURAL, ENGINEERING AND CONSTRUCTION PRODUCTS AND SERVICES (U.S. CLS. 100, 101 AND 107).

CLASS 42—SCIENTIFIC AND COMPUTER SERVICES

FOR COMPUTER SERVICES, NAMELY, PROVIDING SEARCH ENGINES FOR LOCATING INFORMATION, RESOURCES AND THE WEBSITES OF OTHERS ON A GLOBAL COMPUTER NETWORK (U.S. CLS. 100 AND 101).

MARILYN IZZI, EXAMINING ATTORNEY

SN 85-441,795. ST. AMBROSE UNIVERSITY, DAVENPORT, IA. FILED 10-7-2011.



The logo for StAmbrose University features the word "StAmbrose" in a large, bold, serif font, with "University" in a smaller, bold, serif font directly below it. The "St" is smaller and positioned to the left of "Ambrose".

OWNER OF U.S. REG. NOS. 3,744,574, 3,760,570 AND OTHERS.

NO CLAIM IS MADE TO THE EXCLUSIVE RIGHT TO USE "UNIVERSITY", APART FROM THE MARK AS SHOWN.

THE MARK CONSISTS OF THE WORDS "ST AMBROSE UNIVERSITY", WITH THE WORD "UNIVERSITY" WRITTEN UNDER "ST AMBROSE". THE "T" IN "ST" IS CONNECTED TO THE UPPER PART OF THE CAPITAL LETTER "S".

CLASS 25—CLOTHING

FOR CLOTHING, NAMELY, SWEATERS, POLO SHIRTS, T-SHIRTS, AND JACKETS (U.S. CLS. 22 AND 39).

FIRST USE 8-31-2008; IN COMMERCE 8-31-2008.

CLASS 41—EDUCATION AND ENTERTAINMENT

FOR EDUCATIONAL SERVICES, NAMELY, PROVIDING COURSES OF INSTRUCTION AT THE COLLEGE LEVEL; ORGANIZING COLLEGE AND UNIVERSITY SPORTING EXHIBITIONS AND EVENTS; PROVIDING RECREATIONAL SPORTING ACTIVITIES (U.S. CLS. 100, 101 AND 107).

FIRST USE 7-1-2008; IN COMMERCE 7-1-2008.

KRISTIN DAHLING, EXAMINING ATTORNEY

SN 85-441,806. KLAUS INVESTMENTS, L.L.C., DANA POINT, CA. FILED 10-7-2011.

KEYEDIN SOLUTIONS

THE MARK CONSISTS OF STANDARD CHARACTERS WITHOUT CLAIM TO ANY PARTICULAR FONT, STYLE, SIZE, OR COLOR.

NO CLAIM IS MADE TO THE EXCLUSIVE RIGHT TO USE "SOLUTIONS", APART FROM THE MARK AS SHOWN.

CLASS 9—ELECTRICAL AND SCIENTIFIC APPARATUS

FOR COMPUTER SOFTWARE FOR USE IN DATA MANAGEMENT, SALES PROCESS MANAGEMENT, PRODUCT ENGINEERING MANAGEMENT, PURCHASE MANAGEMENT, MATERIALS MANAGEMENT, PROJECT MANAGEMENT, FINANCE MANAGEMENT; COMPUTER SOFTWARE FOR USE IN THE COLLECTION, PROCESSING, STORING, ANALYSIS, REPORTING AND COMMUNICATION OF DATA; COMPUTER SOFTWARE FOR USE IN WORKFORCE AND MOBILE WORKFORCE MANAGEMENT, BUSINESS PROCESS MANAGEMENT, CUSTOMER RELATIONSHIP MANAGEMENT, ENTERPRISE RESOURCE MANAGEMENT, ENTERPRISE CONTENT MANAGEMENT, ECOMMERCE AND ASSET MANAGEMENT (U.S. CLS. 21, 23, 26, 36 AND 38).

CLASS 35—ADVERTISING AND BUSINESS

FOR RESELLER SERVICES, NAMELY, DISTRIBUTORSHIP SERVICES IN THE FIELD OF COMPUTER SOFTWARE (U.S. CLS. 100, 101 AND 102).

CLASS 42—SCIENTIFIC AND COMPUTER SERVICES

FOR PROVIDING TEMPORARY USE OF NONDOWNLOADABLE ENTERPRISE SOFTWARE FOR USE IN DATA MANAGEMENT, SALES PROCESS MANAGEMENT, PRODUCT ENGINEERING MANAGEMENT, PURCHASE MANAGEMENT, MATERIALS MANAGEMENT PROJECT MANAGEMENT, FINANCE MANAGEMENT; PROVIDING TEMPORARY USE OF NONDOWNLOADABLE ENTERPRISE SOFTWARE FOR USE IN THE COLLECTION, PROCESSING, STORING, ANALYSIS, REPORTING AND COMMUNICATION OF DATA; SOFTWARE AS A SERVICE (SAAS), NAMELY, HOSTING SOFTWARE FOR USE IN WORKFORCE AND MOBILE WORKFORCE MANAGEMENT, BUSINESS PROCESS MANAGEMENT, CUSTOMER RELATIONSHIP MANAGEMENT, ENTERPRISE RESOURCE MANAGEMENT, ENTERPRISE CONTENT MANAGEMENT, ECOMMERCE AND ASSET MANAGEMENT; COMPUTER SERVICES FOR OTHERS IN THE FIELD OF DESIGN, SELECTION, IMPLEMENTATION AND USE OF COMPUTER HARDWARE, COMPUTER SOFTWARE AND NETWORKING SYSTEMS; CUSTOM SOFTWARE APPLICATION DEVELOPMENT SERVICES; COMPUTER SOFTWARE UPDATING AND INSTALLATION FOR OTHERS; TECHNICAL SUPPORT SERVICES, NAMELY, TROUBLESHOOTING OF COMPUTER HARDWARE AND SOFTWARE PROBLEMS; COMPUTER SOFTWARE DEVELOPMENT FOR OTHERS (U.S. CLS. 100 AND 101).
FRANK LATTUCA, EXAMINING ATTORNEY

SN 85-441,814. MORADA BAY, INC., ISLAMORADA, FL. FILED 10-7-2011.

MORADA BAY

THE MARK CONSISTS OF STANDARD CHARACTERS WITHOUT CLAIM TO ANY PARTICULAR FONT, STYLE, SIZE, OR COLOR.

CLASS 25—CLOTHING

FOR SHIRTS, SHORT-SLEEVED SHIRTS, T-SHIRTS, HATS, BASEBALL CAPS (U.S. CLS. 22 AND 39).
FIRST USE 3-18-1997; IN COMMERCE 6-17-1997.

CLASS 43—HOTEL AND RESTAURANT SERVICES

FOR RESTAURANT AND CAFE SERVICES, BAR SERVICES (U.S. CLS. 100 AND 101).
FIRST USE 3-18-1997; IN COMMERCE 6-13-1997.
FRANK LATTUCA, EXAMINING ATTORNEY

SN 85-441,963. COMMONWEALTH WHOLESALE DISTRIBUTORS LLC, OLIVE HILL, KY. FILED 10-7-2011.

RED DEVIL'S

THE MARK CONSISTS OF STANDARD CHARACTERS WITHOUT CLAIM TO ANY PARTICULAR FONT, STYLE, SIZE, OR COLOR.

OWNER OF U.S. REG. NO. 580,415.

CLASS 4—LUBRICANTS AND FUELS

FOR BUTANE FUEL; BUTANE GAS CARTRIDGES SOLD FILLED; CANDLES; CANISTERS CONTAINING BUTANE FUEL; CHARCOAL LIGHTER FLUID; LAMP WICKS; LIGHTER FLUID; SOLID FIRE STARTERS; WICKS FOR CANDLES (U.S. CLS. 1, 6 AND 15).

CLASS 5—PHARMACEUTICALS

FOR AIR FRESHENERS; CARPET FRESHENERS AND ODOR ELIMINATORS (U.S. CLS. 6, 18, 44, 46, 51 AND 52).

CLASS 34—SMOKERS' ARTICLES

FOR ASHTRAYS; CIGAR AND CIGARETTE BOXES; CIGAR CASES; CIGAR CUTTERS; CIGAR HOLDERS; CIGAR HUMIDIFIERS; CIGAR LIGHTERS; CIGAR TUBES; CIGAR WRAPS; CIGARETTE CASES; CIGARETTE FILTERS; CIGARETTE HOLDERS; CIGARETTE LIGHTERS NOT FOR LAND VEHICLES; CIGARETTE ROLLING MACHINES; CIGARETTE ROLLING PAPERS; CIGARETTE TUBES; CIGARETTES; CIGARS; FILTER TIPS; FLINTS AND FIRESTONES; LIGHTER FLINTS; PIPE POUCHES; PIPE TAMPERS; PIPE TOBACCO; SMOKER'S ARTICLES, NAMELY, FILTER TUBES; SMOKERS' ARTICLES, NAMELY, CIGAR GLUE; SMOKERS' ARTICLES, NAMELY, CONTAINMENT CLIPS USED TO KEEP A CIGAR FROM FALLING APART; SMOKERS' ARTICLES, NAMELY, KEYSTONES FOR PIPES; SMOKING PIPE CLEANERS; SMOKING PIPES; TOBACCO FILTERS; TOBACCO PIPE CLEANERS; TOBACCO PIPES; TOBACCO WATER PIPES; TOBACCO, CIGARS AND CIGARETTES; WICKS FOR LIGHTERS (U.S. CLS. 2, 8, 9 AND 17).

CURTIS FRENCH, EXAMINING ATTORNEY

SN 85-442,503. ART RESEARCH AND TECHNOLOGY, L.L.C., PHOENIX, AZ. FILED 10-7-2011.

ANZU

THE MARK CONSISTS OF STANDARD CHARACTERS WITHOUT CLAIM TO ANY PARTICULAR FONT, STYLE, SIZE, OR COLOR.

THE ENGLISH TRANSLATION OF "ANZU" IN THE MARK IS "APRICOT".

CLASS 9—ELECTRICAL AND SCIENTIFIC APPARATUS

FOR COMPUTER SOFTWARE FOR ACCESSING DIGITAL FILES, NAMELY, USER-GENERATED CONTENT AND OTHER DIGITAL FILES IN THE FIELD OF BUSINESS AND SOCIAL NETWORKING (U.S. CLS. 21, 23, 26, 36 AND 38).

CLASS 35—ADVERTISING AND BUSINESS

FOR PROMOTING THE GOODS AND SERVICES OF OTHERS VIA A COMPUTER NETWORK; PROVIDING AN ON-LINE SEARCHABLE DATABASE FEATURING DIGITAL FILES, NAMELY, USER-GENERATED CONTENT AND OTHER DIGITAL FILES IN THE FIELD OF BUSINESS (U.S. CLS. 100, 101 AND 102).

CLASS 38—COMMUNICATION

FOR PROVIDING MULTIPLE-USER ACCESS TO A COMPUTER NETWORK (U.S. CLS. 100, 101 AND 104).

CLASS 42—SCIENTIFIC AND COMPUTER SERVICES

FOR PROVIDING TEMPORARY USE OF NON-DOWNLOADABLE COMPUTER SOFTWARE THAT ALLOWS USERS TO ACCESS DIGITAL FILES, NAMELY, USER-GENERATED CONTENT AND OTHER DIGITAL FILES IN THE FIELD OF BUSINESS AND SOCIAL NETWORKING VIA A COMPUTER NETWORK (U.S. CLS. 100 AND 101).

CLASS 45—PERSONAL AND LEGAL SERVICES

FOR PROVIDING AN ON-LINE SEARCHABLE DATABASE FEATURING DIGITAL FILES, NAMELY, USER-GENERATED CONTENT AND OTHER DIGITAL FILES IN THE FIELD OF SOCIAL NETWORKING (U.S. CLS. 100 AND 101).

RONALD MCMORROW, EXAMINING ATTORNEY

SN 85-443,211. THE ASSOCIATION OF POOL AND SPA PROFESSIONALS, ALEXANDRIA, VA. FILED 10-10-2011.

APSP THE ASSOCIATION OF POOL & SPA PROFESSIONALS

THE MARK CONSISTS OF STANDARD CHARACTERS WITHOUT CLAIM TO ANY PARTICULAR FONT, STYLE, SIZE, OR COLOR.

OWNER OF U.S. REG. NO. 3,361,075.

NO CLAIM IS MADE TO THE EXCLUSIVE RIGHT TO USE "THE ASSOCIATION OF POOL & SPA PROFESSIONALS", APART FROM THE MARK AS SHOWN.

CLASS 9—ELECTRICAL AND SCIENTIFIC APPARATUS

FOR ELECTRONIC PUBLICATIONS IN THE NATURE OF BOOKS, MAGAZINES, MANUALS, TEXTBOOKS, WORKBOOKS, NEWSLETTERS, BROCHURES, EDUCATIONAL COURSE MATERIALS, INFORMATION BULLETINS, AND CURRICULUM OUTLINES IN THE FIELD OF POOL AND SPA TECHNOLOGY THAT ARE DOWNLOADABLE FROM THE INTERNET; DOWNLOADABLE MULTIMEDIA FILES CONTAINING ARTWORK, TEXT, AUDIO, VIDEO, AND INTERNET WEB LINKS IN THE NATURE OF STANDARDS, GUIDELINES, REFERENCE MATERIALS, GLOSSARIES, PRESENTATIONS, FORMS, PHOTOGRAPHIC IMAGES, CHARTS, DIAGRAMS, TABLES, ILLUSTRATIONS, GRAPHICS, EXAMINATIONS, QUIZZES, SURVEYS, AND ASSESSMENTS RELATING TO THE FIELD OF POOL AND SPA TECHNOLOGY THAT ARE DOWNLOADABLE FROM THE INTERNET; ELECTRONIC PUBLICATIONS RECORDED ON CD-ROM, AUDIO-TAPE AND VIDEOTAPE, NAMELY, BOOKS, MAGAZINES, MANUALS, TEXTBOOKS, WORKBOOKS, NEWSLETTERS, BROCHURES, EDUCATIONAL COURSE MATERIALS, INFORMATION BULLETINS, AND CURRICULUM OUTLINES IN THE FIELD OF POOL AND SPA TECHNOLOGY; DIGITAL MATERIALS, NAMELY, CD-ROMS, AUDIOTAPES AND VIDEOTAPES FEATURING STANDARDS, GUIDELINES, REFERENCE MATERIALS, GLOSSARIES, PRESENTATIONS, FORMS, PHOTOGRAPHIC IMAGES, CHARTS, DIAGRAMS, TABLES, ILLUSTRATIONS, GRAPHICS, EXAMINATIONS, QUIZZES, SURVEYS, AND ASSESSMENTS RELATING TO THE FIELD OF POOL AND SPA TECHNOLOGY (U.S. CLS. 21, 23, 26, 36 AND 38).

CLASS 16—PAPER GOODS AND PRINTED MATTER

FOR PRINT PUBLICATIONS, NAMELY, BOOKS, MAGAZINES, NEWSLETTER, EDUCATIONAL COURSE MATERIALS AND REFERENCE BOOKS AND GUIDES IN THE FIELD OF POOL AND SPA TECHNOLOGY (U.S. CLS. 2, 5, 22, 23, 29, 37, 38 AND 50).

CLASS 35—ADVERTISING AND BUSINESS

FOR TRADE ASSOCIATION SERVICES, NAMELY, PROMOTING THE INTERESTS OF POOL AND SPA PROFESSIONALS; TRADE ASSOCIATION SERVICES, NAMELY, POLITICAL ADVOCACY SERVICES AT ALL LEVELS OF GOVERNMENT PROMOTING PUBLIC AWARENESS OF ISSUES RELATING TO POOLS AND SPAS AND PROFESSIONALS IN THE POOL AND SPA INDUSTRY (U.S. CLS. 100, 101 AND 102).

CLASS 41—EDUCATION AND ENTERTAINMENT

FOR EDUCATIONAL SERVICES, NAMELY, CONDUCTING CLASSES AND SEMINARS IN THE FIELD OF POOL AND SPA TECHNOLOGY (U.S. CLS. 100, 101 AND 107).

JAY BESCH, EXAMINING ATTORNEY

SN 85-442,931. BERKELEY BIONICS, INC., BERKELEY, CA. FILED 10-9-2011.

EKSO BIONICS

THE MARK CONSISTS OF STANDARD CHARACTERS WITHOUT CLAIM TO ANY PARTICULAR FONT, STYLE, SIZE, OR COLOR.

NO CLAIM IS MADE TO THE EXCLUSIVE RIGHT TO USE "BIONICS", APART FROM THE MARK AS SHOWN.

CLASS 9—ELECTRICAL AND SCIENTIFIC APPARATUS

FOR ROBOTIC NON-MEDICAL EXOSKELETON SYSTEMS WORN BY HUMANS COMPRISING WEARABLE SUPPORTS, BRACES, AND PLATFORMS FOR THE PURPOSE OF ASSISTING HUMAN LOCOMOTION, LIFTING, CARRYING, AND TRANSPORTING LOADS FOR THE PERSON WEARING THE PRODUCT; BODY ARMOR, NAMELY, BULLET-PROOF VESTS, AND BALLISTIC PLATES FOR USE WITH BULLET-PROOF VESTS AND PROTECTIVE CLOTHING (U.S. CLS. 21, 23, 26, 36 AND 38).

CLASS 10—MEDICAL APPARATUS

FOR HUMAN EXOSKELETON SYSTEMS FOR MEDICAL USE CONSISTING OF WEARABLE SUPPORTS AND BRACES FOR USE IN ASSISTING HUMAN LOCOMOTION; ORTHOPEDIC BRACES, ARTIFICIAL LIMBS; ORTHOTICS FOR LIMBS, HANDS, AND FEET; MEDICAL, REHABILITATIVE, THERAPEUTIC AND PHYSICAL THERAPY DEVICES RELATED TO HUMAN INJURY OR MOBILITY, NAMELY, GAIT TRAINERS (U.S. CLS. 26, 39 AND 44).

AMY KELLY, EXAMINING ATTORNEY

SN 85-443,814. CU DIRECT CORPORATION, ONTARIO, CA.
FILED 10-10-2011.

CARZINGA

THE MARK CONSISTS OF STANDARD CHARACTERS WITHOUT CLAIM TO ANY PARTICULAR FONT, STYLE, SIZE, OR COLOR.

CLASS 35—ADVERTISING AND BUSINESS

FOR ONLINE RETAIL STORE SERVICES FEATURING MOTORIZED AND RECREATIONAL VEHICLES; PROVIDING INFORMATION ABOUT MOTORIZED AND RECREATIONAL VEHICLES FOR SALE BY MEANS OF THE INTERNET; PROVIDING INFORMATION ABOUT VEHICLE SPECIFICATIONS, SELECTION, AVAILABILITY, PRICING VEHICLE COMPARISONS, VALUATIONS AND PHOTOGRAPHS OF MOTORIZED AND RECREATIONAL VEHICLES BY MEANS OF THE INTERNET; PROVIDING INFORMATION VIA THE INTERNET RELATED TO THE PURCHASING OF MOTORIZED AND RECREATIONAL VEHICLES (U.S. CLS. 100, 101 AND 102).

CLASS 36—INSURANCE AND FINANCIAL

FOR PROVIDING INFORMATION ABOUT MOTORIZED AND RECREATIONAL VEHICLE FINANCING, INSURANCE, WARRANTIES, AND APPRAISALS BY MEANS OF THE INTERNET; PROVIDING FINANCING, INSURANCE, WARRANTY AND APPRAISAL SERVICES FOR MOTORIZED AND RECREATIONAL VEHICLES BY MEANS OF THE INTERNET; PROVIDING INFORMATION VIA THE INTERNET RELATED TO THE FINANCING OF MOTORIZED AND RECREATIONAL VEHICLES (U.S. CLS. 100, 101 AND 102).

RONALD MCMORROW, EXAMINING ATTORNEY

SN 85-443,870. CORADALE, LLC, NAPA, CA. FILED 10-10-2011.

BESPOKE COLLECTION

THE MARK CONSISTS OF STANDARD CHARACTERS WITHOUT CLAIM TO ANY PARTICULAR FONT, STYLE, SIZE, OR COLOR.

NO CLAIM IS MADE TO THE EXCLUSIVE RIGHT TO USE "COLLECTION", APART FROM THE MARK AS SHOWN.

CLASS 32—LIGHT BEVERAGES

FOR BREWED MALT-BASED ALCOHOLIC BEVERAGE IN THE NATURE OF A BEER; COCONUT-BASED NON-ALCOHOLIC BEVERAGES; ESSENCES FOR MAKING NON-ALCOHOLIC BEVERAGES; FRUIT BEVERAGES; GRAPE JUICE BEVERAGES; ISOTONIC NON-ALCOHOLIC DRINKS; KVASS; NON-ALCOHOLIC BEER; NON-ALCOHOLIC BEVERAGES CONTAINING FRUIT JUICES; NON-ALCOHOLIC BEVERAGES WITH TEA FLAVOR; NON-ALCOHOLIC BEVERAGES, NAMELY, CARBONATED BEVERAGES; NON-ALCOHOLIC CIDER; NON-ALCOHOLIC COCKTAIL BASES; NON-ALCOHOLIC COCKTAIL MIXES; NON-ALCOHOLIC COCKTAILS; NON-ALCOHOLIC COCKTAILS, NAMELY, MOCKTAILS; NON-ALCOHOLIC CORDIALS; NON-ALCOHOLIC DRINKS, NAMELY, ENERGY SHOTS; NON-ALCOHOLIC FRUIT EXTRACTS USED IN THE PREPARATION OF BEVERAGES; NON-ALCOHOLIC FRUIT JUICE BEVERAGES; NON-ALCOHOLIC HONEY-BASED BEVERAGES; NON-ALCOHOLIC MALT BEVERAGE; NON-ALCOHOLIC MALT COOLERS; NON-ALCOHOLIC RICE-BASED BEVERAGES NOT BEING MILK SUBSTITUTES; NON-ALCOHOLIZED WINES; NON-CARBONATED, NON-ALCOHOLIC FROZEN FLAVORED BEVERAGES; PREPARED ENTREES CONSISTING OF FRUIT DRINKS AND FRUIT JUICES, FRUIT-BASED BEVERAGES, NON-ALCOHOLIC BEVERAGES CONTAINING FRUIT JUICES, NON-ALCOHOLIC FRUIT EXTRACTS USED IN THE PREPARATION OF BEVERAGES, NON-ALCOHOLIC FRUIT JUICE BEVERAGES, VEGETABLE JUICES, VEGETABLE-FRUIT JUICES AND SMOOTHIES; PUNCH; SYRUPS FOR MAKING NON-ALCOHOLIC BEVERAGES (U.S. CLS. 45, 46 AND 48).

CLASS 33—WINES AND SPIRITS

FOR APERITIFS; APERITIFS WITH A WINE BASE; CHAMPAGNE; DISTILLED SPIRITS; SPARKLING WINES; WINES (U.S. CLS. 47 AND 49).

CLASS 35—ADVERTISING AND BUSINESS

FOR ART GALLERIES; ART GALLERY SERVICES; BUSINESS CONSULTATION IN THE FIELD OF IMPORTING, EXPORTING, PRODUCING, MANUFACTURING, PACKAGING, DISTRIBUTING, MARKETING, AND PRIVATE LABELING OF ALCOHOLIC BEVERAGES AND NON-ALCOHOLIC BEVERAGES, PROMOTING THE SALE OF ALCOHOLIC BEVERAGES OF OTHERS THROUGH THE DISTRIBUTION OF PRINTED PROMOTIONAL MATERIALS; DEMONSTRATION OF GOODS; DISTRIBUTORSHIPS IN THE FIELD OF WINE; EXPORT AGENCY SERVICES FOR THE GOODS OF OTHERS; EXPORT AND IMPORT AGENCIES; IMPORT AGENCY SERVICES IN THE FIELD OF ALCOHOLIC BEVERAGES; IMPORT-EXPORT AGENCIES IN THE FIELD OF ALCOHOLIC BEVERAGES; ON-LINE ART GALLERIES; ON-LINE WHOLESALE AND RETAIL STORE SERVICES FEATURING WINES; PRODUCT DEMONSTRATION; RETAIL SHOPS FEATURING ART; RETAIL STORE AND ON-LINE RETAIL STORE SERVICES FEATURING ALCOHOLIC BEVERAGES; RETAIL STORE SERVICES FEATURING ALCOHOLIC BEVERAGES; RETAIL STORES FEATURING ART, FURNITURE AND WINE; RETAIL ALCOHOLIC AND NON-ALCOHOLIC BEVERAGES, ART AND FURNITURE STORES (U.S. CLS. 100, 101 AND 102).

CLASS 41—EDUCATION AND ENTERTAINMENT

FOR EDUCATION SERVICES, NAMELY, PROVIDING LIVE AND ON-LINE COURSES AND SEMINARS IN THE FIELD OF WINE SELECTION, EVALUATION, AND ETIQUETTE; TRAINING PERTAINING TO PROMOTION AND MARKETING OF WINE; MUSEUM SERVICES AND EDUCATIONAL SERVICES IN THE NATURE OF WINE TASTING DEMONSTRATIONS; EDUCATION SERVICES, NAMELY, PROVIDING COURSES AND SEMINARS IN THE FIELD OF WINE SELECTION, EVALUATION, AND ETIQUETTE; TRAINING PERTAINING TO PROMOTION AND MARKETING OF WINE; MUSEUM SERVICES AND EDUCATIONAL SERVICES IN THE NATURE OF WINE TASTING DE-

MONSTRATIONS; EDUCATIONAL SERVICES, NAMELY, CONDUCTING PROGRAMS IN THE FIELD OF WINE, EDUCATIONAL SERVICES, NAMELY, COURSES AND SEMINARS PERTAINING TO WINE SELECTION, EVALUATION, AND ETIQUETTE; TRAINING PERTAINING TO PROMOTION AND MARKETING OF WINE; MUSEUM SERVICES AND EDUCATIONAL SERVICES IN THE NATURE OF WINE TASTING DEMONSTRATIONS; GUIDED TOURS OF WINERY, MUSEUMS; MUSEUM CURATOR SERVICES; MUSEUM SERVICES; MUSEUM SERVICES, NAMELY, EXHIBITING TO THE PUBLIC A HISTORICAL SITE; MUSEUMS; PROVIDING EDUCATIONAL DEMONSTRATIONS; RUNNING OF MUSEUMS (U.S. CLS. 100, 101 AND 107).
ANTHONY RINKER, EXAMINING ATTORNEY

SN 85-443,938. BAILEY, JOSEPH, MYRTLE BEACH, SC. FILED 10-11-2011.

iBalance

THE MARK CONSISTS OF STANDARD CHARACTERS WITHOUT CLAIM TO ANY PARTICULAR FONT, STYLE, SIZE, OR COLOR.

CLASS 25—CLOTHING

FOR CLOTHING, NAMELY, GOLF SHIRTS, HATS, JERSEYS, JOGGING SUITS, SKI JACKETS, HOODED SWEATSHIRTS, GLOVES, SKI SUITS, T-SHIRTS (U.S. CLS. 22 AND 39).

CLASS 35—ADVERTISING AND BUSINESS

FOR RETAIL STORE SERVICES FEATURING ARCH SUPPORTS FOR BOOTS AND SHOES, CLOTHING, SWEAT TOWELS, AND SKI SUITS (U.S. CLS. 100, 101 AND 102).

JANICE KIM, EXAMINING ATTORNEY

SN 85-444,101. SEMGROUP CORPORATION, TULSA, OK. FILED 10-11-2011.

ROSE ROCK MIDSTREAM

THE MARK CONSISTS OF STANDARD CHARACTERS WITHOUT CLAIM TO ANY PARTICULAR FONT, STYLE, SIZE, OR COLOR.

NO CLAIM IS MADE TO THE EXCLUSIVE RIGHT TO USE "MIDSTREAM", APART FROM THE MARK AS SHOWN.

CLASS 37—CONSTRUCTION AND REPAIR

FOR GATHERING IN THE NATURE OF DRILLING AND PUMPING OF PETROLEUM PRODUCTS AND CONDENSATES; INSTALLATION AND MAINTENANCE OF CONDENSATE, CRUDE OIL, AND PETROLEUM PRODUCT PIPELINE (U.S. CLS. 100, 103 AND 106).

CLASS 39—TRANSPORTATION AND STORAGE

FOR TRANSMISSION THROUGH PIPELINE, TRUCK, AND TANKER OF PETROLEUM PRODUCTS AND CONDENSATES; TERMINALING SERVICES IN THE NATURE OF PROVIDING PIPELINES TO ENABLE THE TRANSFER OF PETROLEUM PRODUCTS INTO AND OUT OF PIPELINE SYSTEMS; TRANSPORTATION OF PETROLEUM PRODUCTS AND CONDENSATES FOR OTHERS; STORAGE AND HANDLING OF PETROLEUM PRODUCTS AND CONDENSATES; TRANSPORTATION OF PETROLEUM PRODUCTS AND CONDENSATES THROUGH PIPELINES; TRANSPORTATION AND STORAGE OF CRUDE OIL AND CONDENSATES; RENTAL OF SERVICE VEHICLES FOR THE RETRIEVAL, TRANSPORTATION, AND DELIVERY OF CRUDE OIL (U.S. CLS. 100 AND 105).

CLASS 40—MATERIAL TREATMENT

FOR PROCESSING OF CRUDE OIL, LIQUID PETROLEUM GAS, AND CONDENSATES (U.S. CLS. 100, 103 AND 106).

CORY BOONE, EXAMINING ATTORNEY

SN 85-444,135. SEER HEALTH LLC, ALPHARETTA, GA. FILED 10-11-2011.

SEERSPHERE

THE MARK CONSISTS OF STANDARD CHARACTERS WITHOUT CLAIM TO ANY PARTICULAR FONT, STYLE, SIZE, OR COLOR.

CLASS 35—ADVERTISING AND BUSINESS

FOR OUTSOURCING SERVICES IN THE FIELD OF HEALTHCARE ADMINISTRATION (U.S. CLS. 100, 101 AND 102).

CLASS 42—SCIENTIFIC AND COMPUTER SERVICES

FOR MANAGEMENT CONSULTING SERVICES FOR SUPPORTING CLINICAL QUALITY ASSURANCE MANAGEMENT ACTIVITIES IN THE FIELD OF HEALTHCARE; AND SOFTWARE AS A SERVICE (SAAS) SERVICES FEATURING SOFTWARE FOR SUPPORTING CLINICAL QUALITY ASSURANCE MANAGEMENT ACTIVITIES IN THE FIELD OF HEALTHCARE (U.S. CLS. 100 AND 101).

ODESSA BIBBINS, EXAMINING ATTORNEY

SN 85-444,210. AQUION, INC., ELK GROVE VILLAGE, IL.
FILED 10-11-2011.

OWNER OF U.S. REG. NOS. 715,436, 2,633,085 AND OTHERS.

THE MARK CONSISTS OF THE STYLIZED WORD "RAINSOFT" WITH A TEARDROP SHAPED FIGURE IN THE MIDDLE OF THE "S".

CLASS 3—COSMETICS AND CLEANING PREPARATIONS

FOR SOAPS AND DETERGENTS, NAMELY SKIN BAR SOAP, LIQUID HAND SOAP, HAIR SHAMPOO, AUTOMATIC DISHWASHER DETERGENT, LIQUID DISH SOAP AND LAUNDRY DETERGENT (U.S. CLS. 1, 4, 6, 50, 51 AND 52).

FIRST USE 9-1-2004; IN COMMERCE 9-1-2004.

CLASS 6—METAL GOODS

FOR WATER-RETAINING METAL TANK USED IN ASSOCIATION WITH WATER TREATMENT EQUIPMENT (U.S. CLS. 2, 12, 13, 14, 23, 25 AND 50).

FIRST USE 8-1-2000; IN COMMERCE 8-1-2000.

CLASS 7—MACHINERY

FOR CHEMICAL FEED PUMPS (U.S. CLS. 13, 19, 21, 23, 31, 34 AND 35).

FIRST USE 8-1-2000; IN COMMERCE 8-1-2000.

CLASS 11—ENVIRONMENTAL CONTROL APPARATUS

FOR WATER TREATMENT EQUIPMENT, NAMELY, WATER SOFTENERS AND WATER FILTERS; WATER FILTERS, NAMELY, IRON FILTERS, SEDIMENT FILTERS, REVERSE OSMOSIS FILTERS, TASTE AND ODOR FILTERS; WATER TREATMENT EQUIPMENT, NAMELY, ACID NEUTRALIZING UNITS, WATER PURIFIERS, AND FAUCETS WHICH METER THE FLOW OF WATER; ELECTRICAL ULTRAVIOLET LIGHT FOR USE WITH OR AS WATER PURIFICATION UNITS; WATER SOFTENING CONDITIONING UNITS, PRIMARILY FOR DOMESTIC USE; WATER CONDITIONING SYSTEMS COMPOSED PRIMARILY OF WATER FILTRATION UNITS AND WATER CONDITIONING UNITS FOR DOMESTIC, COMMERCIAL, AND INDUSTRIAL USE (U.S. CLS. 13, 21, 23, 31 AND 34).

FIRST USE 8-1-2000; IN COMMERCE 8-1-2000.

TRICIA SONNEBORN, EXAMINING ATTORNEY

SN 85-444,347. UNION SQUARE OPTICAL, INC., NEW YORK, NY. FILED 10-11-2011.



OWNER OF U.S. REG. NO. 4,076,050.

NO CLAIM IS MADE TO THE EXCLUSIVE RIGHT TO USE "OPTICAL", APART FROM THE MARK AS SHOWN.

THE MARK CONSISTS OF THE WORDING "UNION SQUARE OPTICAL" AND A STYLIZED IMAGE OF EYEGLASSES.

CLASS 35—ADVERTISING AND BUSINESS

FOR RETAIL STORE SERVICES FEATURING OPTICAL GOODS CONSISTING OF VARIOUS BRANDS OF EYEGGLASS LENSES AND FRAMES, SUNGLASSES AND CONTACT LENSES (U.S. CLS. 100, 101 AND 102).

FIRST USE 4-0-1992; IN COMMERCE 4-0-1992.

CLASS 44—MEDICAL, BEAUTY AND AGRICULTURAL SERVICES

FOR OPTICIAN SERVICES; OPTOMETRIC SERVICES (U.S. CLS. 100 AND 101).

FIRST USE 4-0-1992; IN COMMERCE 4-0-1992.

ANDREA HACK, EXAMINING ATTORNEY

SN 85-444,349. LIVING INTENTIONALLY FOR EXCELLENCE, LLC, FLINT, MI. FILED 10-11-2011.



THE MARK CONSISTS OF A MISCHIEVOUS CHARACTER OF A BOY WITH WAVY HAIR AND TOOTHY GRIN.

CLASS 9—ELECTRICAL AND SCIENTIFIC APPARATUS

FOR PRE-RECORDED AUDIO CASSETTES AND PRE-RECORDED DIGITAL AUDIO AND VIDEO DISKS FEATURING MOTIVATIONAL AND SELF-IMPROVEMENT INSTRUCTION (U.S. CLS. 21, 23, 26, 36 AND 38).

CLASS 16—PAPER GOODS AND PRINTED MATTER

FOR BOOKS, PRINTED LECTURES, PRINTED LESSONS AND PRINTED EDUCATIONAL MATERIALS, ALL IN THE FIELD OF MOTIVATIONAL AND SELF-IMPROVEMENT INSTRUCTION (U.S. CLS. 2, 5, 22, 23, 29, 37, 38 AND 50).

CLASS 41—EDUCATION AND ENTERTAINMENT

FOR EDUCATIONAL SERVICES, NAMELY, CONDUCTING SEMINARS IN THE FIELD OF MOTIVATIONAL AND SELF-IMPROVEMENT INSTRUCTION AND ON-LINE PUBLICATION OF BOOKS, LECTURES, LESSONS AND EDUCATIONAL MATERIALS IN THE FIELD OF MOTIVATIONAL AND SELF-IMPROVEMENT INSTRUCTION (U.S. CLS. 100, 101 AND 107).

JOHN E. MICHOS, EXAMINING ATTORNEY

SN 85-444,364. SEMGROUP CORPORATION, TULSA, OK.
FILED 10-11-2011.

ROSE ROCK
Midstream

NO CLAIM IS MADE TO THE EXCLUSIVE RIGHT TO USE "MIDSTREAM", APART FROM THE MARK AS SHOWN.

THE MARK CONSISTS OF THE STYLIZED WORDS "ROSE ROCK MIDSTREAM" OVER A DOUBLE UNDERLINE.

CLASS 37—CONSTRUCTION AND REPAIR

FOR GATHERING IN THE NATURE OF DRILLING AND PUMPING OF PETROLEUM PRODUCTS AND CONDENSATES; INSTALLATION AND MAINTENANCE OF CONDENSATE, CRUDE OIL, AND PETROLEUM PRODUCT PIPELINE (U.S. CLS. 100, 103 AND 106).

CLASS 39—TRANSPORTATION AND STORAGE

FOR TRANSMISSION THROUGH PIPELINE, TRUCK, AND TANKER OF PETROLEUM PRODUCTS AND CONDENSATES; TERMINALING SERVICES IN THE NATURE OF PROVIDING PIPELINES TO ENABLE THE TRANSFER OF PETROLEUM PRODUCTS INTO AND OUT OF PIPELINE SYSTEMS; TRANSPORTATION OF PETROLEUM PRODUCTS AND CONDENSATES FOR OTHERS; STORAGE AND HANDLING OF PETROLEUM PRODUCTS AND CONDENSATES; TRANSPORTATION OF PETROLEUM PRODUCTS AND CONDENSATES THROUGH PIPELINES; TRANSPORTATION AND STORAGE OF CRUDE OIL AND CONDENSATES; RENTAL OF SERVICE VEHICLES FOR THE RETRIEVAL, TRANSPORTATION, AND DELIVERY OF CRUDE OIL (U.S. CLS. 100 AND 105).

CLASS 40—MATERIAL TREATMENT

FOR PROCESSING OF CRUDE OIL, LIQUID PETROLEUM GAS, AND CONDENSATES (U.S. CLS. 100, 103 AND 106).

CORY BOONE, EXAMINING ATTORNEY

SN 85-444,424. NEOWIZ INTERNET CORPORATION,
SEOUL, REPUBLIC OF KOREA, FILED 10-11-2011.

DUELPOKER

THE MARK CONSISTS OF STANDARD CHARACTERS WITHOUT CLAIM TO ANY PARTICULAR FONT, STYLE, SIZE, OR COLOR.

CLASS 9—ELECTRICAL AND SCIENTIFIC APPARATUS

FOR RECORDED COMPUTER GAME SOFTWARE; DOWNLOADABLE COMPUTER GAMES PROGRAMS; COMPUTER SOFTWARE FOR WIRELESS CONTENT DELIVERY; DOWNLOADABLE COMPUTER GAME SOFTWARE FOR WIRELESS DEVICES, NAMELY, MOBILE PHONE, SMART PHONE, AND TABLET COMPUTERS (U.S. CLS. 21, 23, 26, 36 AND 38).

CLASS 41—EDUCATION AND ENTERTAINMENT

FOR ENTERTAINMENT SERVICES, NAMELY, PROVIDING ON-LINE COMPUTER GAMES; ELECTRONIC GAME SERVICES PROVIDED VIA INTERNET; ENTERTAINMENT SERVICES, NAMELY, PROVIDING TEMPORARY USE OF NON-DOWNLOADABLE COMPUTER GAMES ACCESSED AND PLAYED VIA MOBILE AND CELLULAR PHONES AND OTHER WIRELESS DEVICES (U.S. CLS. 100, 101 AND 107).

MARC LEIPZIG, EXAMINING ATTORNEY

SN 85-444,443. NEOWIZ INTERNET CORPORATION,
SEOUL, REPUBLIC OF KOREA, FILED 10-11-2011.

TINY WORLD

THE MARK CONSISTS OF STANDARD CHARACTERS WITHOUT CLAIM TO ANY PARTICULAR FONT, STYLE, SIZE, OR COLOR.

CLASS 9—ELECTRICAL AND SCIENTIFIC APPARATUS

FOR RECORDED COMPUTER GAME SOFTWARE; DOWNLOADABLE COMPUTER GAMES PROGRAMS; COMPUTER SOFTWARE FOR WIRELESS CONTENT DELIVERY; DOWNLOADABLE COMPUTER GAME SOFTWARE FOR WIRELESS DEVICES, NAMELY, MOBILE PHONE, SMART PHONE, AND TABLET COMPUTERS (U.S. CLS. 21, 23, 26, 36 AND 38).

CLASS 41—EDUCATION AND ENTERTAINMENT

FOR ENTERTAINMENT SERVICES, NAMELY, PROVIDING ON-LINE COMPUTER GAMES; ELECTRONIC GAME SERVICES PROVIDED VIA INTERNET; ENTERTAINMENT SERVICES, NAMELY, PROVIDING TEMPORARY USE OF NON-DOWNLOADABLE COMPUTER GAMES ACCESSED AND PLAYED VIA MOBILE AND CELLULAR PHONES AND OTHER WIRELESS DEVICES (U.S. CLS. 100, 101 AND 107).

MARC LEIPZIG, EXAMINING ATTORNEY

SN 85-444,730. AMERICAN ACADEMY OF OPHTHALMOLOGY, INC., SAN FRANCISCO, CA. FILED 10-11-2011.

THE EYE M.D. ASSOCIATION

THE MARK CONSISTS OF STANDARD CHARACTERS WITHOUT CLAIM TO ANY PARTICULAR FONT, STYLE, SIZE, OR COLOR.

OWNER OF U.S. REG. NOS. 2,763,591, 2,831,310 AND OTHERS.

NO CLAIM IS MADE TO THE EXCLUSIVE RIGHT TO USE "ASSOCIATION", APART FROM THE MARK AS SHOWN.

SEC. 2(F).

CLASS 38—COMMUNICATION

FOR PROVIDING AN ON-LINE FORUM IN WHICH USERS CAN PARTICIPATE IN DISCUSSIONS ABOUT PROMOTING THE INTERESTS OF OPHTHALMOLOGISTS AND OTHERS IN THE FIELDS OF EYE CARE AND OPHTHALMOLOGY; PROVIDING ONLINE FORUMS FOR TRANSMISSION OF MESSAGES AMONG COMPUTER USERS (U.S. CLS. 100, 101 AND 104).

FIRST USE 2-2-2010; IN COMMERCE 2-2-2010.

CLASS 42—SCIENTIFIC AND COMPUTER SERVICES

FOR COMPUTER SERVICES, NAMELY, CREATING AN ON-LINE INTERACTIVE COMMUNITY FOR REGISTERED USERS TO POST COMMENTS, IMAGES, ELECTRONIC MEDIA, AND INFORMATION OF EDUCATIONAL, INSTRUCTIONAL, AND GENERAL NATURE, ALL RELATED TO EYE CARE AND OPHTHALMOLOGY (U.S. CLS. 100 AND 101).

FIRST USE 2-2-2010; IN COMMERCE 2-2-2010.

LINDA POWELL, EXAMINING ATTORNEY

CLASS 29—MEATS AND PROCESSED FOODS

FOR TINS, JARS, MUGS, TRAYS, AND TUBS SOLD FILLED WITH PROCESSED NUTS, NUT-BASED SNACK FOODS, NAMELY, NUT CLUSTERS, DRIED FRUITS, OR TRAIL MIX CONSISTING PRIMARILY OF PROCESSED NUTS, SEEDS, DRIED FRUIT AND ALSO INCLUDING CHOCOLATE (U.S. CL. 46).

FIRST USE 11-30-2011; IN COMMERCE 11-30-2011.

CLASS 30—STAPLE FOODS

FOR TINS, JARS, MUGS, TRAYS, AND TUBS SOLD FILLED WITH CANDIES, PRETZELS, CHOCOLATE COVERED PRETZELS, YOGURT-COVERED PRETZELS, CHOCOLATES, PEANUT BRITTLE, CHOCOLATE COVERED NUTS, CANDIED NUTS, OR TOFFEES; GROUND COFFEE AND BREWED COFFEE FOR CONSUMPTION ON OR OFF THE PREMISES (U.S. CL. 46).

FIRST USE 11-30-2011; IN COMMERCE 11-30-2011.

MARY ROSSMAN, EXAMINING ATTORNEY

SN 85-444,894. PEELER, BRIAN, LOS ANGELES, CA. FILED 10-11-2011.

Peelerbuilt

THE MARK CONSISTS OF THE STYLIZED TEXT "PEELERBUILT" WITH A LINE UNDER.

CLASS 37—CONSTRUCTION AND REPAIR

FOR GENERAL CONSTRUCTION CONTRACTING (U.S. CLS. 100, 103 AND 106).

FIRST USE 1-1-2008; IN COMMERCE 1-1-2008.

CLASS 41—EDUCATION AND ENTERTAINMENT

FOR PERSONAL FITNESS TRAINING SERVICES AND CONSULTANCY; PERSONAL TRAINING SERVICES, NAMELY, STRENGTH AND CONDITIONING TRAINING; PHYSICAL FITNESS CONDITIONING CLASSES (U.S. CLS. 100, 101 AND 107).

FIRST USE 1-1-2008; IN COMMERCE 1-1-2008.

TARAH HARDY, EXAMINING ATTORNEY

SN 85-444,944. FLEET WHOLESALE SUPPLY CO., INC., APPLETON, WI. FILED 10-11-2011.



NO CLAIM IS MADE TO THE EXCLUSIVE RIGHT TO USE "MARKET", APART FROM THE MARK AS SHOWN.

CLASS 29—MEATS AND PROCESSED FOODS

FOR TINS, JARS, MUGS, TRAYS, AND TUBS SOLD FILLED WITH PROCESSED NUTS, NUT-BASED SNACK FOODS, NAMELY, NUT CLUSTERS, DRIED FRUITS, OR TRAIL MIX CONSISTING PRIMARILY OF PROCESSED NUTS, SEEDS, DRIED FRUIT AND ALSO INCLUDING CHOCOLATE (U.S. CL. 46).

FIRST USE 11-30-2011; IN COMMERCE 11-30-2011.

CLASS 30—STAPLE FOODS

FOR TINS, JARS, MUGS, TRAYS, AND TUBS SOLD FILLED WITH CANDIES, PRETZELS, CHOCOLATE COVERED PRETZELS, YOGURT-COVERED PRETZELS, CHOCOLATES, PEANUT BRITTLE, CHOCOLATE COVERED NUTS, CANDIED NUTS, OR TOFFEES; GROUND COFFEE AND BREWED COFFEE FOR CONSUMPTION ON OR OFF THE PREMISES (U.S. CL. 46).

FIRST USE 11-30-2011; IN COMMERCE 11-30-2011.

MARY ROSSMAN, EXAMINING ATTORNEY

SN 85-444,943. FLEET WHOLESALE SUPPLY CO., INC., APPLETON, WI. FILED 10-11-2011.

MAE'S CORNER MARKET

THE MARK CONSISTS OF STANDARD CHARACTERS WITHOUT CLAIM TO ANY PARTICULAR FONT, STYLE, SIZE, OR COLOR.

NO CLAIM IS MADE TO THE EXCLUSIVE RIGHT TO USE "MARKET", APART FROM THE MARK AS SHOWN.

SN 85-445,033. GAUKEL, LARRY, PEACHLAND, CANADA, FILED 10-12-2011.

SN 85-445,071. NORMAN LOVE CONFECTIONS, INC., FORT MYERS, FL. FILED 10-12-2011.

HARVEY THE HECKLER

THE MARK CONSISTS OF STANDARD CHARACTERS WITHOUT CLAIM TO ANY PARTICULAR FONT, STYLE, SIZE, OR COLOR.

CLASS 25—CLOTHING

FOR CLOTHING, NAMELY, TOPS, BOTTOMS, BASEBALL CAPS, SHIRTS, HEADWEAR, TEE SHIRTS, SOCKS, JACKETS, COATS, SWEATSHIRTS, HOODED SWEATSHIRTS, UNDERWEAR (U.S. CLS. 22 AND 39).

CLASS 28—TOYS AND SPORTING GOODS

FOR GOLF BALLS, GOLF TEES (U.S. CLS. 22, 23, 38 AND 50).
RAUL CORDOVA, EXAMINING ATTORNEY

SN 85-445,042. SUNSHINE SPORTS & MARKETING LLC, DBA SUNSHINE SPORTS, MOSCOW, ID. FILED 10-12-2011.



NO CLAIM IS MADE TO THE EXCLUSIVE RIGHT TO USE "SPORTS & MARKETING LLC", APART FROM THE MARK AS SHOWN.

THE COLOR(S) RED, BLUE, YELLOW, BLACK AND WHITE IS/ARE CLAIMED AS A FEATURE OF THE MARK.

THE MARK CONSISTS OF A ROUND YELLOW FACE OF THE SUN, WITH BLUE AND WHITE EYES AND BLACK SUNGLASSES, RED MOUTH-SMILING, AND THE ENTIRE FACE TRIMMED IN BLACK, YELLOW RAYS EMITTING FROM THE SUN, WITH THE RED LETTERS "SUNSHINE SPORTS" TRIMMED IN YELLOW, A YELLOW "&" SYMBOL, BLUE LETTERS "MARKETING" TRIMMED IN WHITE WITH THE YELLOW LETTERS "LLC".

CLASS 12—VEHICLES

FOR AUTOMOBILE WINDSHIELD SUNSHADES (U.S. CLS. 19, 21, 23, 31, 35 AND 44).
FIRST USE 10-1-2004; IN COMMERCE 10-1-2004.

CLASS 14—JEWELRY

FOR COLLECTIBLE COINS (U.S. CLS. 2, 27, 28 AND 50).
FIRST USE 10-1-2004; IN COMMERCE 10-1-2004.

CLASS 28—TOYS AND SPORTING GOODS

FOR DIVOT REPAIR TOOLS (U.S. CLS. 22, 23, 38 AND 50).
FIRST USE 1-1-2006; IN COMMERCE 1-1-2006.
MARK T. MULLEN, EXAMINING ATTORNEY

ARTISAN GELATO BY NORMAN LOVE

THE MARK CONSISTS OF STANDARD CHARACTERS WITHOUT CLAIM TO ANY PARTICULAR FONT, STYLE, SIZE, OR COLOR.

OWNER OF U.S. REG. NOS. 3,026,858, 3,141,215 AND OTHERS.

NO CLAIM IS MADE TO THE EXCLUSIVE RIGHT TO USE "ARTISAN GELATO", APART FROM THE MARK AS SHOWN.

THE NAME "NORMAN LOVE" IDENTIFIES A LIVING INDIVIDUAL WHOSE CONSENT IS OF RECORD.

CLASS 30—STAPLE FOODS

FOR GELATO, ICE CREAM, GELATO SUNDAES, WAFFLES, CREPES, CAKES, ICE CREAM CAKES, COOKIES, ITALIAN COOKIES, COFFEE, COFFEE-BASED BEVERAGES, BAKERY DESSERTS, ICE CREAM DESSERTS, CANDY AND CHOCOLATES (U.S. CL. 46).

CLASS 35—ADVERTISING AND BUSINESS

FOR RETAIL STORE SERVICES FOR GELATO, ICE CREAM, GELATO SUNDAES, GELATO SHAKES, WAFFLES, CREPES, CAKES, ICE CREAM CAKES, COOKIES, ITALIAN COOKIES, COFFEE, COFFEE-BASED BEVERAGES, BAKERY DESSERTS, ICE CREAM DESSERTS, CANDY AND CHOCOLATES; PASTRY AND DESSERT SHOP SERVICES; RETAIL STORE SERVICES FEATURING ICE CREAM FOR CONSUMPTION OFF THE PREMISES (U.S. CLS. 100, 101 AND 102).

CLASS 43—HOTEL AND RESTAURANT SERVICES

FOR RESTAURANT SERVICES; ICE CREAM PARLORS; ICE CREAM SHOP SERVICES IN THE NATURE OF A RESTAURANT (U.S. CLS. 100 AND 101).

JAMES LOVELACE, EXAMINING ATTORNEY

SN 85-445,097. AKOO INTERNATIONAL, INC., ROSEMONT, IL. FILED 10-12-2011.

AKOO HOOKS YOU UP

THE MARK CONSISTS OF STANDARD CHARACTERS WITHOUT CLAIM TO ANY PARTICULAR FONT, STYLE, SIZE, OR COLOR.

OWNER OF U.S. REG. NO. 3,218,620.

CLASS 38—COMMUNICATION

FOR BROADCASTING SERVICES, NAMELY, TRANSMISSION OF PRERECORDED DIGITAL AUDIO PROGRAMMING, DIGITAL VIDEO PROGRAMMING, ADVERTISING PROGRAMS, TRIVIA GAMES, CONTESTS, AND/OR SWEEPSTAKES (U.S. CLS. 100, 101 AND 104).

CLASS 41—EDUCATION AND ENTERTAINMENT

FOR ENTERTAINMENT SERVICES, NAMELY, PROVIDING PRERECORDED MUSIC PROGRAMMING, PRERECORDED VIDEO PROGRAMMING, ADVERTISING PROGRAMS, AND/OR TRIVIA GAMES, CONDUCTING CONTESTS, AND PROVIDING PRERECORDED AUDIO AND VIDEO PROGRAMMING ACCORDING TO CONSUMER PREFERENCES; SWEEPSTAKE SERVICES (U.S. CLS. 100, 101 AND 107).
ALLISON HOLTZ, EXAMINING ATTORNEY

SN 85-445,100. AKOO INTERNATIONAL, INC., ROSEMONT, IL. FILED 10-12-2011.

AKOO ... HOOK ME UP

THE MARK CONSISTS OF STANDARD CHARACTERS WITHOUT CLAIM TO ANY PARTICULAR FONT, STYLE, SIZE, OR COLOR.

CLASS 38—COMMUNICATION

FOR BROADCASTING SERVICES, NAMELY, TRANSMISSION OF PRERECORDED DIGITAL AUDIO PROGRAMMING, DIGITAL VIDEO PROGRAMMING, ADVERTISING PROGRAMS, TRIVIA GAMES, CONTESTS, AND/OR SWEEPSTAKES (U.S. CLS. 100, 101 AND 104).

CLASS 41—EDUCATION AND ENTERTAINMENT

FOR ENTERTAINMENT SERVICES, NAMELY, PROVIDING PRERECORDED MUSIC PROGRAMMING, PRERECORDED VIDEO PROGRAMMING, ADVERTISING PROGRAMS, AND/OR TRIVIA GAMES, CONDUCTING CONTESTS, AND PROVIDING PRERECORDED AUDIO AND VIDEO PROGRAMMING ACCORDING TO CONSUMER PREFERENCES; SWEEPSTAKE SERVICES (U.S. CLS. 100, 101 AND 107).
ALLISON HOLTZ, EXAMINING ATTORNEY

SN 85-445,131. SEARS BRANDS, LLC, HOFFMAN ESTATES, IL. FILED 10-12-2011.

SHOW US WHAT YOU GOT

THE MARK CONSISTS OF STANDARD CHARACTERS WITHOUT CLAIM TO ANY PARTICULAR FONT, STYLE, SIZE, OR COLOR.

CLASS 35—ADVERTISING AND BUSINESS

FOR RETAIL STORE SERVICES AND ONLINE RETAIL STORE SERVICES FEATURING APPAREL (U.S. CLS. 100, 101 AND 102).
FIRST USE 7-0-2011; IN COMMERCE 7-0-2011.

CLASS 41—EDUCATION AND ENTERTAINMENT

FOR ENTERTAINMENT AND CONTEST SERVICES, NAMELY, CONDUCTING A CONTEST IN WHICH PARTICIPANTS SUBMIT VIDEOS TO COMPETE TO BE SELECTED TO PARTICIPATE IN A FASHION-RELATED ADVERTISING CAMPAIGN; PROVIDING A WEBSITE FOR ENTERTAINMENT PURPOSES WHERE USERS CAN VIEW AND VOTE FOR VIDEOS SUBMITTED BY CONTEST PARTICIPANTS; ON-LINE JOURNALS, NAMELY, BLOGS IN THE FIELD OF FASHION AND STYLE (U.S. CLS. 100, 101 AND 107).

FIRST USE 7-0-2011; IN COMMERCE 7-0-2011.
HEATHER BIDDULPH, EXAMINING ATTORNEY

SN 85-445,152. ENTERASYS NETWORKS, INC., ANDOVER, MA. FILED 10-12-2011.

OneFabric

THE MARK CONSISTS OF STANDARD CHARACTERS WITHOUT CLAIM TO ANY PARTICULAR FONT, STYLE, SIZE, OR COLOR.

CLASS 9—ELECTRICAL AND SCIENTIFIC APPARATUS

FOR COMPUTER HARDWARE AND SOFTWARE FOR USE IN INTERCONNECTING, MANAGING AND OPERATING LOCAL, WIDE AREA, GLOBAL AND OPTICAL NETWORKS (U.S. CLS. 21, 23, 26, 36 AND 38).

CLASS 37—CONSTRUCTION AND REPAIR

FOR PROVIDING INSTALLATION, MAINTENANCE, AND REPAIR SERVICES FOR COMPUTER NETWORKS AND NETWORKING HARDWARE; UPDATING OF COMPUTER HARDWARE (U.S. CLS. 100, 103 AND 106).

CLASS 42—SCIENTIFIC AND COMPUTER SERVICES

FOR CUSTOMER SUPPORT SERVICES IN CONNECTION WITH COMPUTER HARDWARE AND SOFTWARE FOR USE IN INTERCONNECTING, MANAGING, AND OPERATING LOCAL, WIDE AREA, GLOBAL AND OPTICAL NETWORKS, NAMELY, COMPUTER NETWORK DESIGN, COMPUTER CONSULTATION SERVICES, UPDATING OF COMPUTER SOFTWARE, COMPUTER SYSTEMS ANALYSIS, AND ENGINEERING SERVICES (U.S. CLS. 100 AND 101).

RUDY R. SINGLETON, EXAMINING ATTORNEY

SN 85-445,250. BATH & BODY WORKS BRAND MANAGEMENT, INC., REYNOLDSBURG, OH. FILED 10-12-2011.

SUNRISE LAGOON

THE MARK CONSISTS OF STANDARD CHARACTERS WITHOUT CLAIM TO ANY PARTICULAR FONT, STYLE, SIZE, OR COLOR.

CLASS 3—COSMETICS AND CLEANING PREPARATIONS

FOR FRAGRANCE EMITTING WICKS FOR ROOM FRAGRANCE, FRAGRANCES FOR AUTOMOBILES, FRAGRANCES FOR PERSONAL USE, ROOM FRAGRANCE REFILLS FOR ELECTRIC AND NON-ELECTRIC ROOM FRAGRANCE DISPENSERS, ROOM FRAGRANCES, SCENTED LINEN SPRAYS, SCENTED OILS USED TO PRODUCE AROMAS WHEN HEATED, SCENTED ROOM SPRAYS, HOME FRAGRANCE OILS AND FRAGRANCE REEDS SOLD AS A UNIT (U.S. CLS. 1, 4, 6, 50, 51 AND 52).

CLASS 4—LUBRICANTS AND FUELS

FOR CANDLES (U.S. CLS. 1, 6 AND 15).
LOURDES AYALA, EXAMINING ATTORNEY

SN 85-445,252. JONES, JOHN, UNION, MO. FILED 10-12-2011.

**The Lack of Education
Breeds Discrimination,
Don't Discriminate Educate!**

THE MARK CONSISTS OF STANDARD CHARACTERS WITHOUT CLAIM TO ANY PARTICULAR FONT, STYLE, SIZE, OR COLOR.

CLASS 16—PAPER GOODS AND PRINTED MATTER

FOR BINDERS; BUMPER STICKERS; INK PENS; PAPER; POSTERS (U.S. CLS. 2, 5, 22, 23, 29, 37, 38 AND 50).

CLASS 25—CLOTHING

FOR HATS; JACKETS; SWEATERS; T-SHIRTS (U.S. CLS. 22 AND 39).
SEAN CROWLEY, EXAMINING ATTORNEY

SN 85-445,255. BATH & BODY WORKS BRAND MANAGEMENT, INC., REYNOLDSBURG, OH. FILED 10-12-2011.

MALIBU SMASH

THE MARK CONSISTS OF STANDARD CHARACTERS WITHOUT CLAIM TO ANY PARTICULAR FONT, STYLE, SIZE, OR COLOR.

CLASS 3—COSMETICS AND CLEANING PREPARATIONS

FOR FRAGRANCE EMITTING WICKS FOR ROOM FRAGRANCE, FRAGRANCES FOR AUTOMOBILES, FRAGRANCES FOR PERSONAL USE, ROOM FRAGRANCE REFILLS FOR ELECTRIC AND NON-ELECTRIC ROOM FRAGRANCE DISPENSERS, ROOM FRAGRANCES, SCENTED LINEN SPRAYS, SCENTED OILS USED TO PRODUCE AROMAS WHEN HEATED, SCENTED ROOM SPRAYS, HOME FRAGRANCE OILS AND FRAGRANCE REEDS SOLD AS A UNIT (U.S. CLS. 1, 4, 6, 50, 51 AND 52).

CLASS 4—LUBRICANTS AND FUELS

FOR CANDLES (U.S. CLS. 1, 6 AND 15).
LOURDES AYALA, EXAMINING ATTORNEY

SN 85-445,275. TELESTAR CONSULTING INC., BEVERLY HILLS, CA. FILED 10-12-2011.



THE STIPPLING IS FOR SHADING PURPOSES ONLY. THE COLOR(S) GREEN IS/ARE CLAIMED AS A FEATURE OF THE MARK. THE MARK CONSISTS OF THE GREEN TEXT "NATURE-PLAY" WRITTEN IN THE SHAPE OF LEAVES OR A VINE.

CLASS 2—PAINTS

FOR FINGER PAINTS (U.S. CLS. 6, 11 AND 16).
FIRST USE 5-1-2011; IN COMMERCE 5-1-2011.

CLASS 16—PAPER GOODS AND PRINTED MATTER

FOR CARTOON PRINTS; COLOR PENCILS; COLORING BOOKS; CRAYONS; GLUE FOR STATIONERY OR HOUSEHOLD USE; MARKERS (U.S. CLS. 2, 5, 22, 23, 29, 37, 38 AND 50).
FIRST USE 5-1-2011; IN COMMERCE 5-1-2011.
TOBY BULLOFF, EXAMINING ATTORNEY

SN 85-445,290. KEVIN FORD, GRAHAM, GAUTENG, SOUTH AFRICA, FILED 10-12-2011.

B BIZPOOL

THE MARK CONSISTS OF A STYLIZED B SURROUNDED BY CIRCULAR ARROWS FOLLOWED BY BIZ-POOL IN CAPITAL LETTERS.

CLASS 9—ELECTRICAL AND SCIENTIFIC APPARATUS

FOR COMPUTER SOFTWARE FOR THE COLLECTION, EDITING, ORGANIZING, MODIFYING, BOOK MARKING, TRANSMISSION, STORAGE AND SHARING OF DATA AND INFORMATION IN THE FIELDS OF BUSINESS, MARKETING OF GOODS AND SERVICES, COMMUNITY NETWORKING, RECRUITMENT AND EMPLOYMENT (U.S. CLS. 21, 23, 26, 36 AND 38).

CLASS 42—SCIENTIFIC AND COMPUTER SERVICES

SN 85-445,428. PURCHASING POWER, LLC, ATLANTA, GA. FILED 10-12-2011.

FOR PROVIDING TEMPORARY USE OF ON-LINE NON-DOWNLOADABLE SOFTWARE FOR ALLOWING WEB SITE USERS TO COMMUNICATE INFORMATION OF GENERAL INTEREST FOR PURPOSES OF BUSINESS, MARKETING OF GOODS AND SERVICES, COMMUNITY NETWORKING, RECRUITMENT AND EMPLOYMENT; PROVIDING A WEBSITE FEATURING TEMPORARY USE OF NON-DOWNLOADABLE SOFTWARE ENABLING USERS TO SEARCH, LOCATE AND COMMUNICATE WITH OTHERS VIA ELECTRONIC COMMUNICATIONS NETWORKS (U.S. CLS. 100 AND 101).

CHARLES L. JENKINS, EXAMINING ATTORNEY



SN 85-445,341. THE NORTH FACE APPAREL CORP., WILMINGTON, DE. FILED 10-12-2011.

**ATHLETE TESTED.
COMPETITION PROVEN.**

THE MARK CONSISTS OF STANDARD CHARACTERS WITHOUT CLAIM TO ANY PARTICULAR FONT, STYLE, SIZE, OR COLOR.

CLASS 18—LEATHER GOODS

FOR BACKPACKS; DAYPACKS; FANNY PACKS; LUMBAR PACKS; SPORTS PACKS (U.S. CLS. 1, 2, 3, 22 AND 41).

CLASS 20—FURNITURE AND ARTICLES NOT OTHERWISE CLASSIFIED

FOR SLEEPING BAG LINERS; SLEEPING BAG PADS; SLEEPING BAGS (U.S. CLS. 2, 13, 22, 25, 32 AND 50).

CLASS 22—CORDAGE AND FIBERS

FOR TENT FLIES; TENTS (U.S. CLS. 1, 2, 7, 19, 22, 42 AND 50).

CLASS 25—CLOTHING

FOR BOTTOMS; COATS; FOOTWEAR; GLOVES; HEAD WEAR; JACKETS; OUTER JACKETS; RAIN WEAR; SKI BIBS; SKI GLOVES; SKI PANTS; SKI SUITS; SNOW BOARDING SUITS; SNOW PANTS; SNOW SUITS; TOPS (U.S. CLS. 22 AND 39).
CAROLINE WOOD, EXAMINING ATTORNEY

OWNER OF U.S. REG. NO. 3,478,873.
THE MARK CONSISTS OF AN ABSTRACT DRAWING OF A PERSON WITH ARMS RAISED IN FRONT OF A CIRCLE SHAPE.

CLASS 35—ADVERTISING AND BUSINESS

FOR COMPUTERIZED ON-LINE RETAIL STORE SERVICES FEATURING A WIDE VARIETY OF CONSUMER GOODS OF OTHERS; ORGANIZING, ADMINISTERING AND PROVIDING EMPLOYEE AND MEMBER INCENTIVE AND LOYALTY PROGRAMS FOR OTHERS TO IMPROVE EMPLOYEE AND MEMBER ACQUISITION, RETENTION, PERFORMANCE AND LOYALTY BY ALLOWING EMPLOYEES AND MEMBERS TO PURCHASE A WIDE VARIETY OF CONSUMER GOODS OF OTHERS, NAMELY, COMPUTER SYSTEMS, COMPUTER COMPONENTS, COMPUTER SOFTWARE, INTERNET ACCESS PLANS, COMPUTER PERIPHERALS, PRINTERS, TELEVISIONS, VIDEOCASSETTE RECORDERS, DIGITAL VIDEO DISC PLAYERS AND RECORDERS, DIGITAL VIDEO RECORDERS, AUDIO RECEIVERS, AMPLIFIERS, AUDIO SPEAKERS, PORTABLE AUDIO EQUIPMENT, CELLULAR TELEPHONES, PERSONAL DIGITAL ASSISTANTS, DIGITAL CAMERAS, DIGITAL VIDEO CAMCORDERS, HOUSEHOLD APPLIANCES, FITNESS EQUIPMENT, INDOOR FURNITURE, OUTDOOR FURNITURE, AND POWER TOOLS THROUGH A PAYROLL DEDUCTION PLAN; PROMOTING THE GOODS AND SERVICES OF OTHERS VIA PAYROLL DEDUCTION PURCHASE PLANS, PAYROLL DISTRIBUTION PURCHASE PROGRAMS AND PAYROLL ALLOTMENT PURCHASE PROGRAMS (U.S. CLS. 100, 101 AND 102).
FIRST USE 3-1-2008; IN COMMERCE 3-15-2008.

CLASS 36—INSURANCE AND FINANCIAL

FOR ORGANIZING, ADMINISTERING AND PROVIDING EMPLOYEE PAYROLL DEDUCTION PLANS, PAYROLL DISTRIBUTION PURCHASE PROGRAMS AND PAYROLL ALLOTMENT PURCHASE PROGRAMS FOR OTHERS THAT PERMIT EMPLOYEES OR ORGANIZATION MEMBERS TO PURCHASE A WIDE VARIETY OF CONSUMER GOODS OF OTHERS VIA EMPLOYEE PAYROLL DEDUCTIONS, PAYROLL DISTRIBUTION AND PAYROLL ALLOTMENT (U.S. CLS. 100, 101 AND 102).
FIRST USE 3-1-2008; IN COMMERCE 3-15-2008.
NATALIE POLZER, EXAMINING ATTORNEY

SN 85-445,464. COHEN, AMANDA, NEW YORK, NY. FILED 10-12-2011.

Dirt Candy

THE MARK CONSISTS OF STANDARD CHARACTERS WITHOUT CLAIM TO ANY PARTICULAR FONT, STYLE, SIZE, OR COLOR.

CLASS 25—CLOTHING

FOR APRONS; CHILDREN'S AND INFANT'S APPAREL, NAMELY, JUMPERS, OVERALL SLEEPWEAR, PAJAMAS, ROMPERS AND ONE-PIECE GARMENTS; GLOVES; HATS; PANTS; SCARVES; SHIRTS; SOCKS (U.S. CLS. 22 AND 39).

FIRST USE 9-1-2008; IN COMMERCE 9-1-2008.

CLASS 41—EDUCATION AND ENTERTAINMENT

FOR PROVIDING A WEBSITE FEATURING BLOGS AND NON-DOWNLOADABLE PUBLICATIONS IN THE NATURE OF JOURNALS, REVIEWS, LISTINGS, POSTS AND OTHER MEDIA CONTENT IN THE FIELD(S) OF FOOD, FOOD SERVICES, RESTAURANTS AND OTHER CULINARY EXPERIENCES (U.S. CLS. 100, 101 AND 107).

FIRST USE 9-1-2008; IN COMMERCE 9-1-2008.

CLASS 43—HOTEL AND RESTAURANT SERVICES

FOR CATERING; PROVIDING A DATABASE IN THE FIELD OF RECIPES AND COOKING INFORMATION; RESTAURANT; RESTAURANT AND CAFE SERVICES (U.S. CLS. 100 AND 101).

FIRST USE 9-1-2008; IN COMMERCE 9-1-2008.

SUSAN LESLIE DUBOIS, EXAMINING ATTORNEY

SN 85-445,480. HLT INTERNATIONAL IP LLC, MCLEAN, VA. FILED 10-12-2011.

HILTON GRAND VACATIONS

THE MARK CONSISTS OF STANDARD CHARACTERS WITHOUT CLAIM TO ANY PARTICULAR FONT, STYLE, SIZE, OR COLOR.

OWNER OF U.S. REG. NOS. 788,856, 2,478,190 AND OTHERS.

NO CLAIM IS MADE TO THE EXCLUSIVE RIGHT TO USE "VACATIONS", APART FROM THE MARK AS SHOWN.

CLASS 36—INSURANCE AND FINANCIAL

FOR VACATION REAL ESTATE TIME SHARE SERVICES (U.S. CLS. 100, 101 AND 102).

FIRST USE 2-12-2007; IN COMMERCE 2-12-2007.

CLASS 43—HOTEL AND RESTAURANT SERVICES

FOR HOTEL SERVICES; RESTAURANT, CATERING, BAR AND COCKTAIL LOUNGE SERVICES; RESORT LODGING SERVICES; PROVISION OF GENERAL PURPOSE FACILITIES FOR MEETINGS, CONFERENCES AND EXHIBITIONS; PROVISION OF BANQUETING AND SOCIAL FUNCTION FACILITIES FOR SPECIAL OCCASIONS; AND RESERVATION SERVICE FOR HOTEL ACCOMMODATIONS FOR OTHERS (U.S. CLS. 100 AND 101).

FIRST USE 2-12-2007; IN COMMERCE 2-12-2007.

ALLISON HOLTZ, EXAMINING ATTORNEY

SN 85-445,488. CURTIS INSTITUTE OF MUSIC, THE, PHILADELPHIA, PA. FILED 10-12-2011.

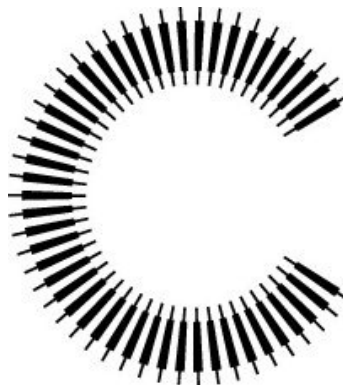

THE MARK CONSISTS OF A STYLIZED DESIGN OF THE LETTER "C" COMPRISED OF BLACK AND WHITE PIANO KEYS.

CLASS 9—ELECTRICAL AND SCIENTIFIC APPARATUS

FOR CDS AND DVDS FEATURING RECORDED MUSIC; COMPUTER APPLICATION SOFTWARE FOR MOBILE PHONES, NAMELY, SOFTWARE FOR PROVIDING INFORMATION ON CLASSICAL MUSICAL PERFORMERS AND PERFORMANCES OF CLASSICAL MUSIC; DIGITAL MUSIC DOWNLOADABLE FROM THE INTERNET (U.S. CLS. 21, 23, 26, 36 AND 38).

FIRST USE 5-0-2009; IN COMMERCE 5-0-2009.

CLASS 16—PAPER GOODS AND PRINTED MATTER

FOR NOTE CARDS, DECORATIVE STICKERS, BUMPER STICKERS, BLANK WRITING JOURNALS (U.S. CLS. 2, 5, 22, 23, 29, 37, 38 AND 50).

FIRST USE 5-0-2009; IN COMMERCE 5-0-2009.

CLASS 18—LEATHER GOODS

FOR TOTE BAGS AND MESSENGER BAGS (U.S. CLS. 1, 2, 3, 22 AND 41).

FIRST USE 5-0-2009; IN COMMERCE 5-0-2009.

CLASS 21—HOUSEWARES AND GLASS

FOR MUGS AND REUSABLE ALUMINUM WATER BOTTLES SOLD EMPTY (U.S. CLS. 2, 13, 23, 29, 30, 33, 40 AND 50).

FIRST USE 5-0-2009; IN COMMERCE 5-0-2009.

CLASS 25—CLOTHING

FOR CLOTHING, NAMELY TEE-SHIRTS, SWEAT-SHIRTS, HATS AND INFANT BODY SUITS (U.S. CLS. 22 AND 39).

FIRST USE 5-0-2009; IN COMMERCE 5-0-2009.

CLASS 41—EDUCATION AND ENTERTAINMENT

FOR INSTRUCTIONAL AND EDUCATIONAL PROGRAMS IN OPERA AND VOCAL AND INSTRUMENTAL CLASSICAL MUSIC LEADING TO UNDERGRADUATE AND GRADUATE DEGREES AND PROFESSIONAL STUDIES CERTIFICATES; ENTERTAINMENT SERVICES IN THE NATURE OF LIVE MUSICAL PERFORMANCES; PROVIDING A WEBSITE FEATURING INFORMATION IN THE FIELD OF CLASSICAL MUSIC AND PROVIDING NON-DOWNLOADABLE PRE-RECORDED MUSIC ACCESSED BY MOBILE COMMUNICATIONS DEVICES VIA A GLOBAL COMPUTER NETWORK AND WIRELESS NETWORKS (U.S. CLS. 100, 101 AND 107).

FIRST USE 5-0-2009; IN COMMERCE 5-0-2009.

DEIRDRE ROBERTSON, EXAMINING ATTORNEY

SN 85-445,643. THE BRADFORD EXCHANGE CHECK COMPANY, LTD., NILES, IL. FILED 10-12-2011.

ARTFUL IMPRESSIONS

THE MARK CONSISTS OF STANDARD CHARACTERS WITHOUT CLAIM TO ANY PARTICULAR FONT, STYLE, SIZE, OR COLOR.

CLASS 16—PAPER GOODS AND PRINTED MATTER

FOR ADDRESS LABELS; ADDRESS STAMPS; ANNOUNCEMENT CARDS; BLANK JOURNALS; BOOK MARKS; BOOK PLATES; BUSINESS CARDS; CALENDARS; CHECKBOOK COVERS; COASTERS OF PAPER; PAPER GIFT CARDS; HOLIDAY CARDS; GREETING CARDS; INK STAMPS; MEMO PADS; NOTE CARDS; NOTE PAPER; PAPER EMBOSSERS; PAPER GIFT TAGS; PAPER LABELS; PAPER NAPKINS; PAPER PICTURE MOUNTS; PICTURE CARDS; PRINTED INVITATIONS; PRINTED RECIPE CARDS; STATIONERY; GIFT WRAPPING PAPER; WRITING INSTRUMENTS, NAMELY, PENS, PENCILS, AND MARKERS (U.S. CLS. 2, 5, 22, 23, 29, 37, 38 AND 50).

CLASS 18—LEATHER GOODS

FOR CARD WALLETS; LUGGAGE TAGS (U.S. CLS. 1, 2, 3, 22 AND 41).

CLASS 35—ADVERTISING AND BUSINESS

FOR MAIL ORDER SERVICES AND ON-LINE RETAIL STORE SERVICES PROVIDED BY MEANS OF A GLOBAL COMPUTER NETWORK, IN THE FIELD OF STATIONERY (U.S. CLS. 100, 101 AND 102).

JOHN GARTNER, EXAMINING ATTORNEY

SN 85-445,663. HEALY, MICHAEL, UXBRIDGE, MA. FILED 10-12-2011.

LOX

THE MARK CONSISTS OF STANDARD CHARACTERS WITHOUT CLAIM TO ANY PARTICULAR FONT, STYLE, SIZE, OR COLOR.

CLASS 3—COSMETICS AND CLEANING PREPARATIONS

FOR BATH AND SHOWER GELS AND SALTS NOT FOR MEDICAL PURPOSES; BATH OILS AND BATH SALTS; BODY LOTIONS; EYE SHADOW; LIP BALM; LIP GLOSS; NAIL POLISH (U.S. CLS. 1, 4, 6, 50, 51 AND 52).

CLASS 14—JEWELRY

FOR COSTUME JEWELRY; JEWELRY AND IMITATION JEWELRY (U.S. CLS. 2, 27, 28 AND 50).

CLASS 16—PAPER GOODS AND PRINTED MATTER

FOR ADDRESS BOOKS AND DIARIES; GIFT WRAP PAPER; GREETING CARDS; PHOTOGRAPH ALBUMS; SCRAPBOOKS; STATIONERY (U.S. CLS. 2, 5, 22, 23, 29, 37, 38 AND 50).

CLASS 18—LEATHER GOODS

FOR ALL-PURPOSE CARRYING BAGS; ATHLETIC BAGS; BABY CARRYING BAGS; BACKPACKS, BOOK BAGS, SPORTS BAGS, BUM BAGS, WALLETS AND HANDBAGS; BEACH BAGS; COSMETIC BAGS SOLD EMPTY (U.S. CLS. 1, 2, 3, 22 AND 41).

CLASS 24—FABRICS

FOR TOWELS (U.S. CLS. 42 AND 50).

CLASS 25—CLOTHING

FOR CAPS; CHILDREN'S AND INFANT'S APPAREL, NAMELY, JUMPERS, OVERALL SLEEPWEAR, PAJAMAS, ROMPERS AND ONE-PIECE GARMENTS; LOUNGEWEAR; SLEEPWEAR; UNDERWEAR (U.S. CLS. 22 AND 39).

BRENDAN REGAN, EXAMINING ATTORNEY

SN 85-445,687. MARS HILL CHURCH, SEATTLE, WA. FILED 10-12-2011.

Re:Sound

THE MARK CONSISTS OF STANDARD CHARACTERS WITHOUT CLAIM TO ANY PARTICULAR FONT, STYLE, SIZE, OR COLOR.

CLASS 9—ELECTRICAL AND SCIENTIFIC APPARATUS

FOR (BASED ON USE IN COMMERCE) SOUND RECORDINGS FEATURING MUSIC; DIGITAL MEDIA, NAMELY, PRE-RECORDED CDS, DOWNLOADABLE AUDIO AND VIDEO RECORDINGS FEATURING MUSIC (U.S. CLS. 21, 23, 26, 36 AND 38).

FIRST USE 6-7-2009; IN COMMERCE 6-7-2009.

CLASS 35—ADVERTISING AND BUSINESS

FOR (BASED ON USE IN COMMERCE) ONLINE RETAIL STORE SERVICES FEATURING SOUND RECORDINGS, DIGITAL MEDIA AND MERCHANDISE (U.S. CLS. 100, 101 AND 102).

FIRST USE 6-7-2009; IN COMMERCE 6-7-2009.

CLASS 45—PERSONAL AND LEGAL SERVICES

FOR (BASED ON INTENT TO USE) LICENSING OF SOUND RECORDINGS AND DIGITAL MEDIA (U.S. CLS. 100 AND 101).

RONALD MCMORROW, EXAMINING ATTORNEY

SN 85-445,722. THE CULT WINE GROUP, INC., DBA E VINO, OWINGS MILLS, MD. FILED 10-12-2011.



NO CLAIM IS MADE TO THE EXCLUSIVE RIGHT TO USE "VINO", APART FROM THE MARK AS SHOWN.

THE MARK CONSISTS OF THE LETTER "E" AND THE WORD "VINO" IN CURSIVE WRITING. A DRAWING OF A WINE GLASS IS INCORPORATED AS PART OF THE BOTTOM OF THE LETTER "E".

CLASS 11—ENVIRONMENTAL CONTROL APPARATUS

FOR REFRIGERATED BEVERAGE DISPENSING UNITS (U.S. CLS. 13, 21, 23, 31 AND 34).

CLASS 33—WINES AND SPIRITS

FOR WINES (U.S. CLS. 47 AND 49).

CLASS 43—HOTEL AND RESTAURANT SERVICES

FOR RENTAL OF DRINK DISPENSING MACHINES (U.S. CLS. 100 AND 101).

BENJAMIN OKEKE, EXAMINING ATTORNEY

SN 85-446,139. SUAZO, HENRY M., BROOKLYN, NY. AND SUAZO, EMERSON, BROOKLYN, NY. FILED 10-13-2011.

cr8tive

THE MARK CONSISTS OF STANDARD CHARACTERS WITHOUT CLAIM TO ANY PARTICULAR FONT, STYLE, SIZE, OR COLOR.

CLASS 25—CLOTHING

FOR SHORT-SLEEVED OR LONG-SLEEVED T-SHIRTS (U.S. CLS. 22 AND 39).

CLASS 35—ADVERTISING AND BUSINESS

FOR ADVERTISING AND PUBLICITY SERVICES, NAMELY, PROMOTING THE GOODS, SERVICES, BRAND IDENTITY AND COMMERCIAL INFORMATION AND NEWS OF THIRD PARTIES THROUGH PRINT, AUDIO, VIDEO, DIGITAL AND ON-LINE MEDIUM (U.S. CLS. 100, 101 AND 102).

MICHAEL ENGEL, EXAMINING ATTORNEY

SN 85-446,156. KOLEV, NIKOLAY, BELLEVUE, WA. AND STELIYANOVA, KREMENA, BELLEVUE, WA. FILED 10-13-2011.

KERA

THE MARK CONSISTS OF STANDARD CHARACTERS WITHOUT CLAIM TO ANY PARTICULAR FONT, STYLE, SIZE, OR COLOR.

CLASS 25—CLOTHING

FOR CARDIGANS; COATS FOR MEN AND WOMEN; FOOTWEAR FOR MEN AND WOMEN; JEANS; MEN'S AND WOMEN'S JACKETS, COATS, TROUSERS, VESTS; MEN'S SUITS, WOMEN'S SUITS; NECKTIES; OVERCOATS; PANTS; PULLOVERS; RAINCOATS; SWEATERS; WOMEN'S CEREMONIAL DRESSES; WOMEN'S CLOTHING, NAMELY, SHIRTS, DRESSES, SKIRTS, BLOUSES; WOMEN'S UNDERWEAR (U.S. CLS. 22 AND 39).

CLASS 35—ADVERTISING AND BUSINESS

FOR WHOLESALE AND RETAIL STORE SERVICES AND ON-LINE RETAIL AND WHOLESALE STORE SERVICES FEATURING FOOTWEAR, UNDERWEAR, CLOTHS, NECKTIES, OVERCOATS, RAINCOATS, SHIRTS, JEANS, JACKETS (U.S. CLS. 100, 101 AND 102).

SANI KHOURI, EXAMINING ATTORNEY

SN 85-446,235. CRYTEK GMBH, FRANKFURT AM MAIN, FED REP GERMANY, FILED 10-13-2011.



OWNER OF ERPN CMNTY TM OFC REG. NO. 009837196, DATED 8-4-2011, EXPIRES 3-24-2021.

THE MARK CONSISTS OF AN EMBLEM FEATURING A CENTRAL FIVE POINT STAR EMBEDDED IN A CIRCULAR DOUBLE RING, THE RING OVERLAYING A WINGED-SHAPE INCLUDING A "W"-LIKE PORTION, ALL APPLIED OVER AN 8-SIDED REAR PORTION OF THE EMBLEM.

CLASS 9—ELECTRICAL AND SCIENTIFIC APPARATUS

FOR COMPUTER SOFTWARE FOR THE MANAGEMENT, TRANSMISSION, STORAGE AND SHARED USE OF COMPUTER GAME PROGRAMS AND OF ELECTRONICALLY STORED INFORMATION VIA COMPUTER NETWORKS FOR USERS; GAME SOFTWARE AND ELECTRONIC GAME PROGRAMS, NAMELY, SOFTWARE GAMES RECORDED ON CD-ROM AND DIGITAL VIDEO DISCS FOR COMPUTERS; SOFTWARE GAMES RECORDED ON CD-ROMS, DIGITAL VIDEO DISCS, AND CARTRIDGES FOR CONSOLE AND INDIVIDUAL, PORTABLE GAMING SYSTEMS; SOFTWARE GAMES THAT ARE DOWNLOADABLE FROM A REMOTE COMPUTER SITE AND ELECTRONIC GAME SOFTWARE FOR MOBILE PHONES, PERSONAL DIGITAL ASSISTANTS, AND HANDHELD COMPUTERS; VIDEO TAPES FEATURING COMEDY, DRAMA, ACTION, ADVENTURE AND/OR ANIMATION; INTEGRATED CIRCUITS CONTAINING RECORDED SOFTWARE FOR USE WITH COMPUTER GAMING CONSOLES AND VIDEO GAME CONSOLES FOR USE WITH AN EXTERNAL DISPLAY SCREEN OR MONITOR; AND MANUALS SOLD TOGETHER AS A UNIT OR PROVIDED VIA DOWNLOAD OR ONLINE WITH AND RELATING TO ANY OF THE FOREGOING (U.S. CLS. 21, 23, 26, 36 AND 38).

CLASS 16—PAPER GOODS AND PRINTED MATTER

FOR BOOKS AND BOOKLETS FEATURING COMEDY, DRAMA, ACTION, ADVENTURE, ANIMATION AND MUSIC; PUBLICATIONS, NAMELY, BROCHURES, BOOKLETS, MANUALS AND TEACHING MATERIALS IN THE FIELD OF COMPUTER AND VIDEO GAMES (U.S. CLS. 2, 5, 22, 23, 29, 37, 38 AND 50).

CLASS 28—TOYS AND SPORTING GOODS

FOR TOYS AND PLAYTHINGS, NAMELY, DOLLS, TOY ACTION FIGURES, PLUSH TOYS AND ACCESSORIES THEREOF, PLAYSETS FOR DOLLS AND TOY ACTION FIGURES, TOY VEHICLES, TOY MODEL HOBBY CRAFT KITS, AND HAND HELD UNITS FOR ELECTRONIC GAMES OTHER THAN THOSE ADAPTED FOR USE WITH AN EXTERNAL DISPLAY SCREEN OR MONITOR (U.S. CLS. 22, 23, 38 AND 50).

CLASS 41—EDUCATION AND ENTERTAINMENT

FOR ENTERTAINMENT SERVICES, NAMELY, PROVIDING AN ON-LINE COMPUTER GAME FOR OTHERS OVER GLOBAL AND LOCAL AREA COMPUTER NETWORKS AND PROVIDING INFORMATION ON-LINE RELATING TO COMPUTER GAMES, VIDEO GAMES AND COMPUTER AND VIDEO GAMES RELATED PRODUCTS; MULTIMEDIA PUBLISHING OF BOOKS, MAGAZINES, JOURNALS, SOFTWARE, GAMES, MUSIC AND ELECTRONIC PUBLICATIONS (U.S. CLS. 100, 101 AND 107).

JAMES A. RAUEN, EXAMINING ATTORNEY

SN 85-446,413. PERRY EQUIPMENT CORPORATION, MINERAL WELLS, TX. FILED 10-13-2011.

XTREAMPURE

THE MARK CONSISTS OF STANDARD CHARACTERS WITHOUT CLAIM TO ANY PARTICULAR FONT, STYLE, SIZE, OR COLOR.

CLASS 7—MACHINERY

FOR FLUID FILTERS, NAMELY, OIL FILTERS AND FUEL FILTERS FOR USE IN THE OIL AND GAS, REFINERY, PETROCHEMICAL, AND INDUSTRIAL WATER MARKETS (U.S. CLS. 13, 19, 21, 23, 31, 34 AND 35).

CLASS 11—ENVIRONMENTAL CONTROL APPARATUS

FOR FLUID FILTERS, NAMELY, WATER FILTERS FOR USE IN THE OIL AND GAS, REFINERY, PETROCHEMICAL, AND INDUSTRIAL WATER MARKETS (U.S. CLS. 13, 21, 23, 31 AND 34).

DAVID MURRAY, EXAMINING ATTORNEY

SN 85-446,414. FELLERS, JAMES DOUGLAS, ROUND ROCK, TX. FILED 10-13-2011.

Neon Cow

THE MARK CONSISTS OF STANDARD CHARACTERS WITHOUT CLAIM TO ANY PARTICULAR FONT, STYLE, SIZE, OR COLOR.

CLASS 9—ELECTRICAL AND SCIENTIFIC APPARATUS

FOR COMPUTER E-COMMERCE SOFTWARE TO ALLOW USERS TO PERFORM ELECTRONIC BUSINESS TRANSACTIONS VIA A GLOBAL COMPUTER NETWORK; COMPUTER GAME SOFTWARE; COMPUTER HARDWARE AND PERIPHERAL DEVICES AND COMPUTER SOFTWARE FOR DATA COMMUNICATION AND TRANSLATING AND TRANSMITTING DATA SOLD THEREWITH; COMPUTER HARDWARE AND SOFTWARE SYSTEM FOR TRACKING PEOPLE, OBJECTS AND PETS USING GPS DATA ON A DEVICE ON THE TRACKED PEOPLE, OBJECTS AND PETS; ELECTRONIC GAME SOFTWARE FOR HANDHELD ELECTRONIC DEVICES (U.S. CLS. 21, 23, 26, 36 AND 38).

CLASS 35—ADVERTISING AND BUSINESS

FOR ADVERTISEMENT VIA MOBILE PHONE NETWORKS; ADVERTISING AND COMMERCIAL INFORMATION SERVICES, VIA THE INTERNET; ADVERTISING AND MARKETING SERVICES PROVIDED BY MEANS OF INDIRECT METHODS OF MARKETING COMMUNICATIONS, NAMELY, SOCIAL MEDIA, SEARCH ENGINE MARKETING, INQUIRY MARKETING, INTERNET MARKETING, MOBILE MARKETING, BLOGGING AND OTHER FORMS OF PASSIVE, SHARABLE OR VIRAL COMMUNICATIONS CHANNELS; ADVERTISING AND MARKETING SERVICES, NAMELY, PROMOTING THE GOODS AND SERVICES OF OTHERS; ADVERTISING, MARKETING AND PROMOTING THE GOODS AND SERVICES OF OTHERS USING KIOSKS; ANALYSIS OF MARKET RESEARCH DATA AND STATISTICS; ARRANGING AND CONDUCTING MARKETING PROMOTIONAL EVENTS FOR OTHERS; BUSINESS CONSULTATION AND MANAGEMENT REGARDING MARKETING ACTIVITIES AND LAUNCHING OF NEW PRODUCTS; BUSINESS MONITORING AND CONSULTING SERVICES, NAMELY, TRACKING WEB SITES AND APPLICATIONS OF OTHERS TO PROVIDE STRATEGY, INSIGHT, MARKETING, SALES, OPERATION, PRODUCT DESIGN, PARTICULARLY SPECIALIZING IN THE USE OF ANALYTIC AND STATISTIC MODELS FOR THE UNDERSTANDING AND PREDICTING OF CONSUMERS, BUSINESSES, AND MARKET TRENDS AND ACTIONS; CONSULTATION SERVICES, NAMELY, CREATIVE AND STRATEGIC CONSULTATION REGARDING DEVELOPMENT AND PRODUCTION OF MARKETING CAMPAIGNS FOR OTHERS (U.S. CLS. 100, 101 AND 102).

KATHERINE CONNOLLY, EXAMINING ATTORNEY

SN 85-446,442. AMES TRUE TEMPER, INC., CAMP HILL, PA. FILED 10-13-2011.

LEAK-NO-MORE

THE MARK CONSISTS OF STANDARD CHARACTERS WITHOUT CLAIM TO ANY PARTICULAR FONT, STYLE, SIZE, OR COLOR.

CLASS 6—METAL GOODS

FOR MANUALLY-OPERATED METAL HOSE REEL (U.S. CLS. 2, 12, 13, 14, 23, 25 AND 50).

CLASS 20—FURNITURE AND ARTICLES NOT OTHERWISE CLASSIFIED

FOR MANUALLY-OPERATED PLASTIC HOSE REEL (U.S. CLS. 2, 13, 22, 25, 32 AND 50).
CARYN GLASSER, EXAMINING ATTORNEY

SN 85-446,460. ONENEWS CORPORATION, MIAMI BEACH, FL. FILED 10-13-2011.

ONENEWS

THE MARK CONSISTS OF STANDARD CHARACTERS WITHOUT CLAIM TO ANY PARTICULAR FONT, STYLE, SIZE, OR COLOR.

CLASS 35—ADVERTISING AND BUSINESS

FOR MARKET RESEARCH, MARKET ANALYSIS AND MARKET INTELLIGENCE SERVICES (U.S. CLS. 100, 101 AND 102).

FIRST USE 9-24-2009; IN COMMERCE 2-15-2011.

CLASS 38—COMMUNICATION

FOR (BASED ON INTENT TO USE) VIDEO TRANSMISSION OVER DIGITAL NETWORKS; (BASED ON USE) NEWS AGENCIES, NAMELY, THE TRANSMISSION OF NEWS ITEMS TO NEWS REPORTING ORGANIZATIONS (U.S. CLS. 100, 101 AND 104).

FIRST USE 5-22-2006; IN COMMERCE 7-13-2006.

FRANK LATTUCA, EXAMINING ATTORNEY

SN 85-446,509. APEX INDUSTRIAL TECHNOLOGIES LLC, MASON, OH. FILED 10-13-2011.

APEX SUPPLY CHAIN TECHNOLOGIES

THE MARK CONSISTS OF STANDARD CHARACTERS WITHOUT CLAIM TO ANY PARTICULAR FONT, STYLE, SIZE, OR COLOR.

NO CLAIM IS MADE TO THE EXCLUSIVE RIGHT TO USE "SUPPLY CHAIN TECHNOLOGIES", APART FROM THE MARK AS SHOWN.

CLASS 9—ELECTRICAL AND SCIENTIFIC APPARATUS

FOR AUTOMATED DISPENSING SYSTEMS COMPRISING STORAGE, DISPENSING, ELECTRONIC ACCESS CONTROL AND TRACKING UNITS, AND MACHINES FOR HARDWARE, PARTS, SUPPLIES, COMPONENTS AND THE LIKE (U.S. CLS. 21, 23, 26, 36 AND 38).

FIRST USE 4-1-2011; IN COMMERCE 4-1-2011.

CLASS 41—EDUCATION AND ENTERTAINMENT

FOR COMPUTER SERVICES, NAMELY, PROVIDING A WEB-BASED SYSTEM AND ONLINE PORTAL FEATURING ON-LINE NON-DOWNLOADABLE SOFTWARE FOR USE IN TRACKING, PROCESSING AND PROVIDING USER ACCESS TO DATA RELATING TO DISPENSING, ACCESS AND USAGE OF HARDWARE, PARTS, SUPPLIES, COMPONENTS AND THE LIKE, AND FOR USE IN SUPPLY CHAIN MANAGEMENT, INVENTORY CONTROL, ACCESS CONTROL, DEMAND MANAGEMENT AND PROCESS CONTROL (U.S. CLS. 100, 101 AND 107).

FIRST USE 4-1-2011; IN COMMERCE 4-1-2011.

VIVIAN MICZNIK FIRST, EXAMINING ATTORNEY

SN 85-446,514. APEX INDUSTRIAL TECHNOLOGIES LLC, MASON, OH. FILED 10-13-2011.



NO CLAIM IS MADE TO THE EXCLUSIVE RIGHT TO USE "SUPPLY CHAIN TECHNOLOGIES", APART FROM THE MARK AS SHOWN.

THE MARK CONSISTS OF THE WORDS "APEX SUPPLY CHAIN TECHNOLOGIES" IN A STYLIZED FORM, WITH THE WORD "APEX" ABOVE "SUPPLY CHAIN TECHNOLOGIES". THERE ARE 4 LINES TO THE LEFT AND RIGHT OF THE WORD "APEX" AND A LINE BETWEEN "APEX" AND "SUPPLY CHAIN TECHNOLOGIES".

CLASS 9—ELECTRICAL AND SCIENTIFIC APPARATUS

FOR AUTOMATED DISPENSING SYSTEMS COMPRISING STORAGE, DISPENSING, ELECTRONIC ACCESS CONTROL AND TRACKING UNITS, AND MACHINES FOR HARDWARE, PARTS, SUPPLIES, COMPONENTS AND THE LIKE (U.S. CLS. 21, 23, 26, 36 AND 38).

FIRST USE 4-1-2011; IN COMMERCE 4-1-2011.

CLASS 41—EDUCATION AND ENTERTAINMENT

FOR COMPUTER SERVICES, NAMELY, PROVIDING A WEB-BASED SYSTEM AND ONLINE PORTAL FEATURING ON-LINE NON-DOWNLOADABLE SOFTWARE FOR USE IN TRACKING, PROCESSING AND PROVIDING USER ACCESS TO DATA RELATING TO DISPENSING, ACCESS AND USAGE OF HARDWARE, PARTS, SUPPLIES, COMPONENTS AND THE LIKE, AND FOR USE IN SUPPLY CHAIN MANAGEMENT, INVENTORY CONTROL, ACCESS CONTROL, DEMAND MANAGEMENT AND PROCESS CONTROL (U.S. CLS. 100, 101 AND 107).

FIRST USE 4-1-2011; IN COMMERCE 4-1-2011. VIVIAN MICZNIK FIRST, EXAMINING ATTORNEY

SN 85-446,543. BECOMING ONE, LLC, SEATTLE, WA. FILED 10-13-2011.



THE COLOR(S) GREEN, GRAY, ORANGE, BLUE AND PURPLE IS/ARE CLAIMED AS A FEATURE OF THE MARK.

THE MARK CONSISTS OF DOTS IN THE COLORS GREEN, GRAY, ORANGE, BLUE AND PURPLE ARRANGED IN A SPIRAL PATTERN WITH CURVED LINES RADIATING OUTWARD FROM A CENTRAL GRAY DOT.

CLASS 25—CLOTHING

FOR (BASED ON INTENT TO USE) APPAREL, NAMELY, SHIRTS, PANTS, SHORTS, TIGHTS, SPORTS BRAS AND CLOTHING INTENDED TO BE WORN DURING THE PRACTICE OF YOGA, NAMELY, SHIRTS, PANTS, TIGHTS, TANK TOPS AND SHORTS (U.S. CLS. 22 AND 39).

CLASS 41—EDUCATION AND ENTERTAINMENT

FOR (BASED ON USE IN COMMERCE) EDUCATIONAL AND ENTERTAINMENT SERVICES, NAMELY, PROVIDING CLASSES, WORKSHOPS, SEMINARS, RETREATS AND PRESENTATIONS, ALL IN THE FIELDS OF YOGA, BREATHING CIRCLES, CENTERING AND HOLISTIC MIND-BODY CONNECTIONS (U.S. CLS. 100, 101 AND 107).

FIRST USE 9-1-2011; IN COMMERCE 9-1-2011. JEFFREY LOOK, EXAMINING ATTORNEY

SN 85-446,561. SOUND LIBERATION FRONT LLC, BROOKLYN, NY. FILED 10-13-2011.

Dub Invasion

THE MARK CONSISTS OF STANDARD CHARACTERS WITHOUT CLAIM TO ANY PARTICULAR FONT, STYLE, SIZE, OR COLOR.

NO CLAIM IS MADE TO THE EXCLUSIVE RIGHT TO USE "DUB", APART FROM THE MARK AS SHOWN.

CLASS 9—ELECTRICAL AND SCIENTIFIC APPARATUS

FOR MUSICAL SOUND RECORDINGS; AUDIOVISUAL RECORDINGS FEATURING MUSIC AND MUSICAL ENTERTAINMENT; DOWNLOADABLE MUSICAL SOUND RECORDINGS; DOWNLOADABLE AUDIOVISUAL RECORDINGS FEATURING MUSIC AND MUSICAL ENTERTAINMENT; PRE-RECORDED DVDS, CDS AND DOWNLOADABLE AUDIOVISUAL RECORDINGS FEATURING MUSIC AND MUSICAL ENTERTAINMENT; DOWNLOADABLE RINGTONES, GRAPHICS AND MUSIC VIA A GLOBAL COMPUTER NETWORK AND WIRELESS DEVICES; DOWNLOADABLE ELECTRONIC PUBLICATIONS IN THE NATURE OF MAGAZINES, NEWSLETTERS, CATALOGS, AND BOOKLETS IN THE FIELDS OF MUSIC, THE MUSIC INDUSTRY, MUSICAL ENTERTAINMENT, MUSICAL RECORDINGS, AND MUSICAL ARTISTS; SOUND FILES IN MACHINE-READABLE FORM, RECORDED AND DOWNLOADABLE, NAMELY, MUSICAL RECORDINGS INCLUDED IN THIS CLASS; IMAGE AND SOUND FILES IN MACHINE-READABLE FORM, RECORDED AND DOWNLOADABLE, NAMELY, MUSICAL AUDIOVISUAL RECORDINGS INCLUDED IN THIS CLASS (U.S. CLS. 21, 23, 26, 36 AND 38).

CLASS 41—EDUCATION AND ENTERTAINMENT

FOR ENTERTAINMENT SERVICES, NAMELY, PRODUCING OR CONDUCTING LIVE MUSIC CONCERTS; ARRANGING AND CONDUCTING MUSIC FESTIVALS AND TOURING MUSIC FESTIVALS FEATURING A VARIETY OF MUSICIANS, MUSICAL GROUPS, ENTERTAINERS AND OTHER MUSICAL ENTERTAINMENT; PROVIDING A WEBSITE FEATURING INFORMATION ON ENTERTAINMENT, MUSIC AND MUSIC FESTIVALS; PROVIDING ONLINE PROFILE PAGES FEATURING RECORDED MUSIC, MUSICAL PERFORMANCES, MUSICAL VIDEOS, RELATED VIDEO CLIPS, PHOTOGRAPHS, TOUR INFORMATION, BIOGRAPHICAL INFORMATION AND OTHER ENTERTAINMENT INFORMATION ON A MUSIC FESTIVAL; PRODUCTION OF SOUND AND MUSIC VIDEO RECORDING FOR OTHERS, NAMELY, PRODUCTION OF MUSICAL CDS, DVDS, AND VIDEO CASSETTES (U.S. CLS. 100, 101 AND 107).

FIRST USE 3-15-2011; IN COMMERCE 3-15-2011.
JUSTINE D. PARKER, EXAMINING ATTORNEY

SN 85-446,609. NATURAL SUPPLEMENT ASSOCIATION, INCORPORATED, ABBOTT PARK, IL. FILED 10-13-2011.

MYOPLEX 30

THE MARK CONSISTS OF STANDARD CHARACTERS WITHOUT CLAIM TO ANY PARTICULAR FONT, STYLE, SIZE, OR COLOR.

OWNER OF U.S. REG. NOS. 2,515,633, 2,679,254 AND 3,420,728.

NO CLAIM IS MADE TO THE EXCLUSIVE RIGHT TO USE "30", APART FROM THE MARK AS SHOWN.

CLASS 5—PHARMACEUTICALS

FOR NUTRITIONAL SUPPLEMENTS; DIETARY SUPPLEMENTS (U.S. CLS. 6, 18, 44, 46, 51 AND 52).

CLASS 29—MEATS AND PROCESSED FOODS

FOR PROTEIN BASED, NUTRIENT-DENSE SNACK BARS; SHAKES (U.S. CL. 46).

CLASS 30—STAPLE FOODS

FOR READY TO EAT, CEREAL DERIVED FOOD BARS (U.S. CL. 46).

CHRISTINA SOBRAL, EXAMINING ATTORNEY

SN 85-446,631. BRACKEN TECHNOLOGY SERVICES, INC., DBA CARLTON TECHNOLOGIES, INC., HOLLAND, MI. FILED 10-13-2011.

**WE MAKE THINGS WORK.
BETTER.**

THE MARK CONSISTS OF STANDARD CHARACTERS WITHOUT CLAIM TO ANY PARTICULAR FONT, STYLE, SIZE, OR COLOR.

CLASS 35—ADVERTISING AND BUSINESS

FOR VALUE-ADDED RESELLER SERVICES FEATURING REFURBISHED COMPUTER HARDWARE, COMPUTER EQUIPMENT AND TELEPHONES (U.S. CLS. 100, 101 AND 102).

CLASS 37—CONSTRUCTION AND REPAIR

FOR REFURBISHMENT, MAINTENANCE AND REPAIR OF COMPUTER HARDWARE AND EQUIPMENT, AND TELEPHONE-RELATED HARDWARE AND EQUIPMENT; TECHNICAL SUPPORT SERVICES AND TROUBLESHOOTING IN THE FIELDS OF COMPUTER HARDWARE AND TELEPHONES (U.S. CLS. 100, 103 AND 106).

AMY C. KEAN, EXAMINING ATTORNEY

SN 85-446,637. ODD FUTURE, LLC, LOS ANGELES, CA. FILED 10-13-2011.

ODD FUTURE

THE MARK CONSISTS OF STANDARD CHARACTERS WITHOUT CLAIM TO ANY PARTICULAR FONT, STYLE, SIZE, OR COLOR.

CLASS 9—ELECTRICAL AND SCIENTIFIC APPARATUS

FOR MUSICAL SOUND RECORDINGS; DOWNLOADABLE MUSICAL SOUND RECORDINGS (U.S. CLS. 21, 23, 26, 36 AND 38).

FIRST USE 11-0-2008; IN COMMERCE 11-0-2008.

CLASS 41—EDUCATION AND ENTERTAINMENT

FOR ENTERTAINMENT, NAMELY, LIVE MUSICAL CONCERTS, ARRANGING AND CONDUCTING CONCERTS AND MUSICAL EVENTS; ENTERTAINMENT SERVICES, NAMELY, PERSONAL APPEARANCES BY PROFESSIONAL ENTERTAINERS (U.S. CLS. 100, 101 AND 107).

FIRST USE 11-8-2010; IN COMMERCE 11-8-2010.
LIEF MARTIN, EXAMINING ATTORNEY

SN 85-446,696. WHALEN, SARAH, LOS ANGELES, CA. FILED 10-13-2011.

DOGGIE LAMA

THE MARK CONSISTS OF STANDARD CHARACTERS WITHOUT CLAIM TO ANY PARTICULAR FONT, STYLE, SIZE, OR COLOR.

CLASS 16—PAPER GOODS AND PRINTED MATTER

FOR CHILDREN'S BOOKS (U.S. CLS. 2, 5, 22, 23, 29, 37, 38 AND 50).

CLASS 21—HOUSEWARES AND GLASS

FOR PLATES; CUPS AND MUGS; DRINKING CUPS FOR CHILDREN AND PARTS AND FITTINGS THEREFOR, NAMELY, DRINKING CUPS FOR CHILDREN SOLD AS A UNIT WITH NON-INSULATED LIDS; DRINKING CUPS FOR BABIES AND CHILDREN AND PARTS AND FITTINGS THEREFOR, NAMELY, CUPS FOR BABIES AND CHILDREN SOLD AS A UNIT WITH VALVES AND LIDS (U.S. CLS. 2, 13, 23, 29, 30, 33, 40 AND 50).

CLASS 25—CLOTHING

FOR CHILDREN'S CLOTHING, NAMELY, TOPS, BOTTOMS, UNDERWEAR, SOCKS, HEADWEAR, PAJAMAS, SWEATSHIRTS, JACKETS, COATS, BOOTS, SHOES (U.S. CLS. 22 AND 39).

CLASS 28—TOYS AND SPORTING GOODS

FOR STUFFED ANIMALS; TOY ACTION FIGURES AND ACCESSORIES THEREFOR (U.S. CLS. 22, 23, 38 AND 50).

ELLEN PERKINS, EXAMINING ATTORNEY

SN 85-446,701. MEDIAPOWER, INC., SOUTH PORTLAND, ME. FILED 10-13-2011.

MEDIAPOWER

THE MARK CONSISTS OF STANDARD CHARACTERS WITHOUT CLAIM TO ANY PARTICULAR FONT, STYLE, SIZE, OR COLOR.

CLASS 35—ADVERTISING AND BUSINESS

FOR ADVERTISING AND BUSINESS SERVICES, NAMELY, SECURING AIRTIME ON ALL FORMS OF MEDIA COMMUNICATIONS STATIONS, SYSTEMS, NETWORKS, AND SERVICES FOR THE PURPOSE OF PROMOTING THE GOODS AND SERVICES OF OTHERS, ADVERTISING AND PUBLICITY SERVICES, NAMELY, PROMOTING THE GOODS, SERVICES, BRAND IDENTITY AND COMMERCIAL INFORMATION AND NEWS OF THIRD PARTIES THROUGH PRINT, AUDIO, VIDEO, DIGITAL AND ON-LINE MEDIUM, ADVERTISING, MARKETING AND PROMOTION SERVICES, NAMELY, PROMOTING THE GOODS AND SERVICES OF OTHERS, ANALYSIS OF ADVERTISING RESPONSE, BUSINESS MARKETING AND DIRECT MAIL CONSULTING SERVICES, BUSINESS SERVICES, NAMELY, DEVELOPING CATALOGS, BROCHURES, AND OTHER PRINT ADVERTISING AND TRACKING AND MONITORING OF CALLS FOR OTHERS IN RESPONSE TO ADVERTISING ADS, CUSTOMER SERVICE MANAGEMENT FOR OTHERS, CUSTOMER SERVICES, NAMELY, RESPONDING TO CUSTOMERS INQUIRIES FOR OTHERS IN THE FIELD OF NUTRACEUTICALS VIA TELEPHONE OR OTHER ELECTRONIC MEANS, CONSULTATION IN THE FIELD OF COMMERCIALS OR INFOMERCIALS, DEVELOPMENT OF MARKETING STRATEGIES AND CONCEPTS, DIRECT RESPONSE RETAIL SERVICES BY MEANS OF INFOMERCIALS IN THE FIELD OF NUTRACEUTICALS, DIRECT MAIL ADVERTISING SERVICES, DIRECT MARKETING ADVERTISING FOR OTHERS, DIRECT MARKETING CONSULTING SERVICES, DIRECT MARKETING OF HEALTH PRODUCTS AND NUTRITIONAL SUPPLEMENTS FOR OTHERS, MEDIA BUYING ADVICE, NAMELY, ADVISING THE CLIENT HOW MUCH MEDIA TIME, AND AT WHAT TIMES THE CLIENT SHOULD BE PURCHASING ADVERTISING, MEDIA PLANNING, NAMELY, ADVISING THE CLIENT ON THE CORRECT TIMES AND STATIONS TO ADVER-

TISE BASED ON MEDIA ANALYSIS OF THE MARKET FOR THAT MEDIA, ORDER FULFILLMENT SERVICES, ORGANIZATION OF PROMOTIONS USING AUDIOVISUAL MEDIA, PRODUCING AUDIO AND VIDEO INFOMERCIALS, PRODUCTION AND DISTRIBUTION OF RADIO AND TELEVISION COMMERCIALS, PROMOTIONAL MARKETING SERVICES USING AUDIOVISUAL MEDIA, PROVIDING ADVERTISING, MARKETING AND PROMOTIONAL SERVICES, NAMELY, DEVELOPMENT OF ADVERTISING CAMPAIGNS FOR TELEVISION, RADIO, PRINT MEDIA, AND WEB SITES, PROVIDING CONSULTING SERVICES IN THE FIELD OF FACILITATING THE PLANNING, BUYING, AND SELLING OF MEDIA, MARKETING CONSULTING, MARKETING RESEARCH SERVICES, AND TELEMARKETING (U.S. CLS. 100, 101 AND 102).

FIRST USE 4-4-1995; IN COMMERCE 4-4-1995.

CLASS 39—TRANSPORTATION AND STORAGE

FOR PACKING, CRATING AND WAREHOUSING SERVICES (U.S. CLS. 100 AND 105).

FIRST USE 4-4-1995; IN COMMERCE 4-4-1995.

CLASS 41—EDUCATION AND ENTERTAINMENT

FOR MEDIA PRODUCTION SERVICES, NAMELY, VIDEO AND FILM PRODUCTION (U.S. CLS. 100, 101 AND 107).

FIRST USE 4-4-1995; IN COMMERCE 4-4-1995.

CLASS 42—SCIENTIFIC AND COMPUTER SERVICES

FOR PRODUCT DEVELOPMENT CONSULTATION (U.S. CLS. 100 AND 101).

FIRST USE 4-4-1995; IN COMMERCE 4-4-1995.

SUSAN LESLIE DUBOIS, EXAMINING ATTORNEY

SN 85-446,724. BALL, JARRETT MARK, ALBUQUERQUE, NM. FILED 10-13-2011.



THE MARK CONSISTS OF THE WORD FORGIVEN WITH A CROSS AND CROWN OF THORNS AS THE I, SCRIPTURE ACTS 13:38 UNDER THE WORD FORGIVEN.

CLASS 24—FABRICS

FOR GOLF TOWELS (U.S. CLS. 42 AND 50).

CLASS 25—CLOTHING

FOR GOLF CAPS; GOLF CLEATS; GOLF PANTS, SHIRTS AND SKIRTS; GOLF SHIRTS; GOLF SHORTS; GOLF TROUSERS (U.S. CLS. 22 AND 39).

CLASS 28—TOYS AND SPORTING GOODS

FOR DIVOT REPAIR TOOLS; FITTED HEAD COVERS FOR GOLF CLUBS; GOLF ACCESSORY POUCHES; GOLF BAG COVERS; GOLF BAG TAGS; GOLF BAGS; GOLF BALL MARKERS; GOLF BALL SLEEVES; GOLF BALLS; GOLF CLUB BAGS; GOLF CLUB COVERS; GOLF FLAGS; GOLF TEE MARKERS; GOLF TEES; HEAD COVERS FOR GOLF CLUBS (U.S. CLS. 22, 23, 38 AND 50).

BRIAN PINO, EXAMINING ATTORNEY

SN 85-446,776. IMMUNOTOPIA, LLC, BOERNE, TX. FILED
10-13-2011.SN 85-446,741. HEFFERNAN, STEVEN, TAPPAN, NY. FILED
10-13-2011.

BOARDER-X

THE MARK CONSISTS OF STANDARD CHARACTERS WITHOUT CLAIM TO ANY PARTICULAR FONT, STYLE, SIZE, OR COLOR.

CLASS 32—LIGHT BEVERAGES

FOR BEERS (U.S. CLS. 45, 46 AND 48).

CLASS 43—HOTEL AND RESTAURANT SERVICES

FOR BREWPUB SERVICES; RESTAURANT SERVICES, NAMELY, PROVIDING OF FOOD AND BEVERAGES FOR CONSUMPTION ON AND OFF THE PREMISES (U.S. CLS. 100 AND 101).

GENE MACIOL, EXAMINING ATTORNEY

THE MARK CONSISTS OF THE STYLIZED WORDING "SMARTCOFFEE" WITH A GRAPHIC OF A GRADUATION CAP OVER THE LETTER "S" AND A GRAPHIC OF A COFFEE BEAN REPLACING THE LETTER "O".

CLASS 5—PHARMACEUTICALS

FOR ANTIOXIDANT ENRICHED COFFEE (U.S. CLS. 6, 18, 44, 46, 51 AND 52).

CLASS 30—STAPLE FOODS

FOR BEVERAGES MADE OF COFFEE; BEVERAGES WITH A COFFEE BASE; COFFEE; COFFEE; COFFEE BEANS; COFFEE ESSENCES FOR USE AS SUBSTITUTES FOR COFFEE; COFFEE EXTRACTS; COFFEE-BASED BEVERAGES; GREEN COFFEE; GROUND COFFEE BEANS; ICED COFFEE; INSTANT COFFEE; ROASTED COFFEE BEANS (U.S. CL. 46).

ALYSSA STEEL, EXAMINING ATTORNEY

SN 85-446,755. BASKINS ACQUISITION HOLDINGS, LLC,
LIVINGSTON, TX. FILED 10-13-2011.

OWNER OF U.S. REG. NO. 3,272,004.
THE MARK CONSISTS OF THE WORD BASKINS WITH A STYLIZED I CONTAINING A STAR.

CLASS 25—CLOTHING

FOR BELTS; DRESSES; PANTS; SHIRTS; SHOES (U.S. CLS. 22 AND 39).
FIRST USE 8-1-2010; IN COMMERCE 8-1-2010.

CLASS 35—ADVERTISING AND BUSINESS

FOR RETAIL STORE SERVICES, NAMELY, RETAIL AND ONLINE WESTERN WEAR STORE FEATURING WESTERN WEAR, ACCESSORIES, AND SOUVENIRS (U.S. CLS. 100, 101 AND 102).

FIRST USE 8-1-2010; IN COMMERCE 8-1-2010.
JOHN DALIER, EXAMINING ATTORNEY

SN 85-446,789. OTIS ELEVATOR COMPANY, FARMING-
TON, CT. FILED 10-13-2011.

THE MARK CONSISTS OF STANDARD CHARACTERS WITHOUT CLAIM TO ANY PARTICULAR FONT, STYLE, SIZE, OR COLOR.

CLASS 7—MACHINERY

FOR ELEVATORS, ESCALATORS, AND MOVING WALKWAYS (U.S. CLS. 13, 19, 21, 23, 31, 34 AND 35).

CLASS 37—CONSTRUCTION AND REPAIR

FOR INSTALLATION, MAINTENANCE AND REPAIR OF ELEVATORS, ESCALATORS, AND MOVING WALKWAYS (U.S. CLS. 100, 103 AND 106).

GENE MACIOL, EXAMINING ATTORNEY

SN 85-446,807. ULTA SALON, COSMETICS & FRAGRANCE, INC., BOLINGBROOK, IL. FILED 10-13-2011.

21 DAYS BEAUTY

THE MARK CONSISTS OF STANDARD CHARACTERS WITHOUT CLAIM TO ANY PARTICULAR FONT, STYLE, SIZE, OR COLOR.

NO CLAIM IS MADE TO THE EXCLUSIVE RIGHT TO USE "BEAUTY", APART FROM THE MARK AS SHOWN.

CLASS 35—ADVERTISING AND BUSINESS

FOR RETAIL STORE SERVICES FEATURING HEALTH AND BEAUTY AIDS, PERFUMES, JEWELRY, WATCHES AND PHARMACEUTICALS (U.S. CLS. 100, 101 AND 102).

FIRST USE 9-1-2010; IN COMMERCE 9-1-2010.

CLASS 44—MEDICAL, BEAUTY AND AGRICULTURAL SERVICES

FOR BEAUTY SALON SERVICES, NAMELY, HAIR CUTTING, HAIRDRESSING, FACIALS, SKIN CARE, NAIL CARE, MANICURES AND PEDICURES (U.S. CLS. 100 AND 101).

FIRST USE 9-1-2010; IN COMMERCE 9-1-2010.
COLLEEN DOMBROW, EXAMINING ATTORNEY

CLASS 42—SCIENTIFIC AND COMPUTER SERVICES

FOR COMPUTER SERVICES, NAMELY, CREATING AN ON-LINE COMMUNITY FOR REGISTERED USERS TO GET FEEDBACK FROM THEIR PEERS, FROM VIRTUAL COMMUNITIES, ENGAGE IN SOCIAL NETWORKING AND POST, EXCHANGE AND VIEW INFORMATION, RATINGS, REVIEWS AND COMMENTARY ABOUT BEAUTY, WELLNESS AND HEALTHY LIFESTYLE MATTERS, PRODUCTS AND SERVICES; HOSTING AN ONLINE COMMUNITY WEBSITE FEATURING A FORUM THAT ALLOWS USERS TO POST, EXCHANGE AND VIEW INFORMATION, RATINGS, REVIEWS AND COMMENTARY ABOUT BEAUTY, WELLNESS AND HEALTHY LIFESTYLE MATTERS, PRODUCTS AND SERVICES, FORM VIRTUAL COMMUNITIES AND ENGAGE IN SOCIAL NETWORKING; PROVIDING A WEBSITE THAT GIVES COMPUTER USERS THE ABILITY TO POST, EXCHANGE AND VIEW INFORMATION, RATINGS, REVIEWS AND COMMENTARY ABOUT BEAUTY, WELLNESS AND HEALTHY LIFESTYLE MATTERS, PRODUCTS AND SERVICES (U.S. CLS. 100 AND 101).

CLASS 44—MEDICAL, BEAUTY AND AGRICULTURAL SERVICES

FOR PROVIDING INFORMATION ABOUT BEAUTY, WELLNESS AND LIFESTYLE WELLNESS VIA THE INTERNET (U.S. CLS. 100 AND 101).

CLASS 45—PERSONAL AND LEGAL SERVICES

FOR PROVIDING INFORMATION ABOUT LIFESTYLES VIA THE INTERNET; PROVIDING INFORMATION CONCERNING CONSUMER PRODUCT SAFETY IN THE FIELD OF BEAUTY, WELLNESS AND HEALTHY LIFESTYLE PRODUCTS; ON-LINE SOCIAL NETWORKING SERVICES (U.S. CLS. 100 AND 101).

DAVID YONTEF, EXAMINING ATTORNEY

SN 85-446,971. GET SHAVED, LLC., WOODLAND HILLS, CA. FILED 10-13-2011.

SN 85-446,899. BEAUTY UNITES, L.L.C., WASHINGTON, DC. FILED 10-13-2011.

beautyunites



THE MARK CONSISTS OF STANDARD CHARACTERS WITHOUT CLAIM TO ANY PARTICULAR FONT, STYLE, SIZE, OR COLOR.

CLASS 35—ADVERTISING AND BUSINESS

FOR PROVIDING CONSUMER PRODUCT INFORMATION IN THE FIELD OF BEAUTY, WELLNESS AND HEALTHY LIFESTYLE PRODUCTS VIA THE INTERNET (U.S. CLS. 100, 101 AND 102).

THE MARK CONSISTS OF A HALF CIRCLE, WITH SWIRLS UNDER THE HALF CIRCLE, WHICH IS ABOVE THE WORDS "GET SHAVED"; WITH TWO DRIPS EXTENDING BELOW THE WORDS "GET SHAVED". THE HALF CIRCLE, THE WORDS "GET SHAVED" AND THE TWO DRIPS ARE OUTLINED.

CLASS 30—STAPLE FOODS

FOR SHAVED ICE CONFECTIONS (U.S. CL. 46).

CLASS 35—ADVERTISING AND BUSINESS

FOR RETAIL STORES FEATURING SHAVED ICE CONFECTIONS (U.S. CLS. 100, 101 AND 102).

CLASS 43—HOTEL AND RESTAURANT SERVICES

FOR PROVIDING OF FOOD AND DRINK VIA A MOBILE TRUCK AND/OR CATERING (U.S. CLS. 100 AND 101).

AMY HELLA, EXAMINING ATTORNEY

SN 85-447,023. JPD MEDIA, INC., MONA VALE, SYDNEY, NSW, AUSTRALIA, FILED 10-13-2011.

DURIEDESIGN

NO CLAIM IS MADE TO THE EXCLUSIVE RIGHT TO USE "DESIGN", APART FROM THE MARK AS SHOWN.

THE MARK CONSISTS OF THE WORDS "DURIE DESIGN" WITH A BACKWARDS "D" BETWEEN "DURIE" AND "DESIGN".

CLASS 42—SCIENTIFIC AND COMPUTER SERVICES

FOR LANDSCAPE ARCHITECTURAL DESIGN; LANDSCAPE LIGHTING DESIGN (U.S. CLS. 100 AND 101).

FIRST USE 7-0-2008; IN COMMERCE 7-0-2008.

CLASS 44—MEDICAL, BEAUTY AND AGRICULTURAL SERVICES

FOR LANDSCAPE DESIGN (U.S. CLS. 100 AND 101).

FIRST USE 7-0-2008; IN COMMERCE 7-0-2008.

RONALD MCMORROW, EXAMINING ATTORNEY

SN 85-447,026. RHINO INDUSTRIES, INC., MORRISON, CO. FILED 10-13-2011.

White Rhino

THE MARK CONSISTS OF STANDARD CHARACTERS WITHOUT CLAIM TO ANY PARTICULAR FONT, STYLE, SIZE, OR COLOR.

CLASS 35—ADVERTISING AND BUSINESS

FOR ASSISTANCE IN BUSINESS MANAGEMENT AND PRODUCT COMMERCIALIZATION, WITHIN THE FRAMEWORK OF A FRANCHISE CONTRACT; FRANCHISING, NAMELY, CONSULTATION AND ASSISTANCE IN BUSINESS MANAGEMENT, ORGANIZATION AND PROMOTION (U.S. CLS. 100, 101 AND 102).

CLASS 37—CONSTRUCTION AND REPAIR

FOR COMPREHENSIVE PREVENTATIVE MAINTENANCE SERVICE FOR ROOFING SYSTEMS; ROOFING CONSULTATION; ROOFING CONTRACTING; ROOFING INSTALLATION; ROOFING REPAIR; ROOFING SERVICES (U.S. CLS. 100, 103 AND 106).

EDWARD NELSON, EXAMINING ATTORNEY

SN 85-447,038. THE BOARD OF EDUCATION OF THE CITY OF CHICAGO, CHICAGO, IL. FILED 10-13-2011.

VIRTUAL PRE-K

THE MARK CONSISTS OF STANDARD CHARACTERS WITHOUT CLAIM TO ANY PARTICULAR FONT, STYLE, SIZE, OR COLOR.

OWNER OF U.S. REG. NO. 2,617,682.

SEC. 2(F).

CLASS 9—ELECTRICAL AND SCIENTIFIC APPARATUS

FOR EDUCATIONAL KITS COMPRISING DVDS, CDS AND VIDEOTAPES FEATURING EDUCATIONAL INSTRUCTION AND ACTIVITIES FOR CHILDREN, ALONG WITH PRINTED PROVIDER MANUALS, TEACHER MANUALS AND ACTIVITY CARDS, SOLD AS A UNIT (U.S. CLS. 21, 23, 26, 36 AND 38).

FIRST USE 10-29-2001; IN COMMERCE 10-29-2001.

CLASS 41—EDUCATION AND ENTERTAINMENT

FOR PROVIDING COURSES OF INSTRUCTION FOR CHILDREN THROUGH AN INTERACTIVE INTERNET WEB SITE (U.S. CLS. 100, 101 AND 107).

FIRST USE 10-29-2001; IN COMMERCE 10-29-2001.

KEVON CHISOLM, EXAMINING ATTORNEY

SN 85-447,085. REALISE GLOBAL LIMITED, ROMSEY, UNITED KINGDOM, FILED 10-13-2011.

MEETINGSPIHERE

THE MARK CONSISTS OF STANDARD CHARACTERS WITHOUT CLAIM TO ANY PARTICULAR FONT, STYLE, SIZE, OR COLOR.

CLASS 9—ELECTRICAL AND SCIENTIFIC APPARATUS

FOR COMPUTER SOFTWARE PROGRAM FOR ELECTRONIC MEETING SYSTEMS, EXCHANGE OF MESSAGES BETWEEN PARTICIPANTS, AGENDA PLANNING AND AUTOMATIC CREATION AND PROVISIONING OF MEETING MINUTES (U.S. CLS. 21, 23, 26, 36 AND 38).

CLASS 35—ADVERTISING AND BUSINESS

FOR BUSINESS ASSISTANCE, ADVISORY AND CONSULTING SERVICES IN THE FIELD OF ELECTRONIC MEETING SYSTEMS AND ELECTRONIC FACILITATION SERVICES FOR BUSINESS WORKSHOPS AND CONFERENCES (U.S. CLS. 100, 101 AND 102).

CLASS 38—COMMUNICATION

FOR TELECONFERENCING AND VIDEO CONFERENCING SERVICES; DELIVERY OF MESSAGES BY ELECTRONIC TRANSMISSION; ELECTRONIC MESSAGE SENDING; TRANSMISSION OF MESSAGES OVER ELECTRONIC MEDIA (U.S. CLS. 100, 101 AND 104).

CLASS 42—SCIENTIFIC AND COMPUTER SERVICES

FOR COMPUTER AND TECHNOLOGICAL PROFESSIONAL SERVICES, NAMELY, PROVIDING COMPUTER CONSULTING SERVICES FOR ELECTRONIC MEETING SYSTEMS; SOFTWARE AS A SERVICE (SAAS) SERVICES FEATURING SOFTWARE FOR EXCHANGE OF MESSAGES BETWEEN PARTICIPANTS, AGENDA PLANNING AND AUTOMATIC CREATION AND PROVISIONING OF MEETING MINUTES (U.S. CLS. 100 AND 101).

BENJAMIN OKEKE, EXAMINING ATTORNEY

SN 85-447,113. KETTERHAGEN, KOURTNEY, LOS ANGELES, CA. FILED 10-13-2011.

Mommyopathy

THE MARK CONSISTS OF STANDARD CHARACTERS WITHOUT CLAIM TO ANY PARTICULAR FONT, STYLE, SIZE, OR COLOR.

CLASS 3—COSMETICS AND CLEANING PREPARATIONS

FOR NATURAL ESSENTIAL OILS (U.S. CLS. 1, 4, 6, 50, 51 AND 52).

CLASS 5—PHARMACEUTICALS

FOR HOMEOPATHIC SUPPLEMENTS (U.S. CLS. 6, 18, 44, 46, 51 AND 52).

CLASS 44—MEDICAL, BEAUTY AND AGRICULTURAL SERVICES

FOR HOLISTIC HEALTH SERVICES FEATURING HERBAL MEDICINE (U.S. CLS. 100 AND 101).

WON TEAK OH, EXAMINING ATTORNEY

SN 85-447,131. FAB FOUNDATIONS, LLC, CABIN JOHN, MD. FILED 10-13-2011.

Fab Foundations

THE MARK CONSISTS OF STANDARD CHARACTERS WITHOUT CLAIM TO ANY PARTICULAR FONT, STYLE, SIZE, OR COLOR.

CLASS 9—ELECTRICAL AND SCIENTIFIC APPARATUS

FOR (BASED ON INTENT TO USE) DIGITAL MATERIALS, NAMELY, DOWNLOADABLE E-BOOKS FEATURING WOMEN'S SELF IMPROVEMENT (U.S. CLS. 21, 23, 26, 36 AND 38).

CLASS 16—PAPER GOODS AND PRINTED MATTER

FOR (BASED ON USE IN COMMERCE) A SERIES OF BOOKS AND WRITTEN ARTICLES IN THE FIELD OF WOMEN'S SELF IMPROVEMENT (U.S. CLS. 2, 5, 22, 23, 29, 37, 38 AND 50).

FIRST USE 1-17-2011; IN COMMERCE 2-3-2011.

CLASS 35—ADVERTISING AND BUSINESS

FOR (BASED ON USE IN COMMERCE) MARKETING CONSULTING (U.S. CLS. 100, 101 AND 102).

FIRST USE 1-17-2011; IN COMMERCE 2-3-2011.

CLASS 41—EDUCATION AND ENTERTAINMENT

FOR (BASED ON USE IN COMMERCE) EDUCATION SERVICES, NAMELY, PROVIDING SEMINARS IN THE FIELD OF WOMEN'S SELF IMPROVEMENT; ON-LINE JOURNALS, NAMELY, BLOGS FEATURING WOMEN'S SELF IMPROVEMENT (U.S. CLS. 100, 101 AND 107).

FIRST USE 1-17-2011; IN COMMERCE 2-3-2011.

NAPOLEON SHARMA, EXAMINING ATTORNEY

SN 85-447,193. CITY-BLAST MEDIA, INC., TORONTO, ONTARIO, CANADA, FILED 10-13-2011.

SMLS

THE MARK CONSISTS OF STANDARD CHARACTERS WITHOUT CLAIM TO ANY PARTICULAR FONT, STYLE, SIZE, OR COLOR.

PRIORITY CLAIMED UNDER SEC. 44(D) ON CANADA APPLICATION NO. 1547112, FILED 10-10-2011.

CLASS 35—ADVERTISING AND BUSINESS

FOR ADVERTISING OF COMMERCIAL OR RESIDENTIAL REAL ESTATE; PROVIDING MARKETING SOLUTIONS FOR REAL ESTATE PROFESSIONALS; PROVIDING REAL ESTATE LEADS FOR PROSPECTIVE PURCHASERS; REAL ESTATE ADVERTISING SERVICES; REAL ESTATE MARKETING SERVICES IN THE FIELD OF RESIDENTIAL HOMES (U.S. CLS. 100, 101 AND 102).

CLASS 36—INSURANCE AND FINANCIAL

FOR PROVIDING A DATABASE OF INFORMATION ABOUT RESIDENTIAL REAL ESTATE LISTINGS IN DIFFERENT NEIGHBORHOODS AND COMMUNITIES; PROVIDING AN INTERNET WEBSITE PORTAL OFFERING INFORMATION IN THE FIELDS OF REAL ESTATE CONCERNING THE PURCHASE AND SALE OF NEW AND RESALE HOMES AND CONDOS; PROVIDING INFORMATION IN THE FIELD OF REAL ESTATE BY MEANS OF LINKING THE WEB SITE TO OTHER WEB SITES FEATURING REAL ESTATE INFORMATION; PROVIDING INFORMATION IN THE FIELD OF REAL ESTATE VIA THE INTERNET; PROVIDING REAL ESTATE LISTINGS AND REAL ESTATE INFORMATION VIA THE INTERNET; PROVIDING REAL ESTATE LISTINGS VIA THE INTERNET; REAL ESTATE MULTIPLE LISTING SERVICES (U.S. CLS. 100, 101 AND 102).

FONG HSU, EXAMINING ATTORNEY

SN 85-447,242. NAPORA, KRZYSZTOF, WALLINGTON, NJ. FILED 10-13-2011.



THE MARK CONSISTS OF THE WORDS "QUALITY STAR" WITH A LINE DRAWN UNDERNEATH AND FOUR LITTLE STARS UNDER THE LINE AND A BIG STAR DRAWN AROUND AND TO THE RIGHT OF THE WORD "STAR".

CLASS 35—ADVERTISING AND BUSINESS

FOR RETAIL STORE SERVICES FEATURING REPLACEMENT WINDOWS, SIDINGS, INSULATED SIDING, ENTRY DOORS, STORM DOORS, GARAGE DOORS, SEAMLESS GUTTERS, GUTTER LEAF PROTECTION SYSTEMS, WINDOW AWNING SYSTEMS, WINDOW DRESSINGS, WINDOW SECURITY BARS, WINDOW/GLASS FILMS, WINDOW STORM COVER SYSTEMS, SUN ROOM ENCLOSURES, PATIO ENCLOSURES; ADVERTISING AND PROMOTIONAL SERVICES (U.S. CLS. 100, 101 AND 102).

SN 85-447,233. NAPORA, KRZYSZTOF, WALLINGTON, NJ. FILED 10-13-2011.

QUALITY STAR

CLASS 37—CONSTRUCTION AND REPAIR

FOR BUILDING CONSTRUCTION SERVICES, NAMELY, INSTALLATION AND REPAIR OF WINDOWS, SIDINGS, INSULATED SIDING, ENTRY DOORS, STORM DOORS, GARAGE DOORS, SEAMLESS GUTTERS, GUTTER LEAF PROTECTION SYSTEMS, WINDOW AWNING SYSTEMS, WINDOW DRESSINGS, WINDOW SECURITY BARS, WINDOW/GLASS FILMS, WINDOW STORM COVER SYSTEMS, SUN ROOM ENCLOSURES, AND PATIO ENCLOSURES (U.S. CLS. 100, 103 AND 106).

DAVID I, EXAMINING ATTORNEY

THE MARK CONSISTS OF STANDARD CHARACTERS WITHOUT CLAIM TO ANY PARTICULAR FONT, STYLE, SIZE, OR COLOR.

CLASS 35—ADVERTISING AND BUSINESS

FOR RETAIL STORE SERVICES FEATURING REPLACEMENT WINDOWS, SIDINGS, INSULATED SIDING, ENTRY DOORS, STORM DOORS, GARAGE DOORS, SEAMLESS GUTTERS, GUTTER LEAF PROTECTION SYSTEMS, WINDOW AWNING SYSTEMS, WINDOW DRESSINGS, WINDOW SECURITY BARS, WINDOW/GLASS FILMS, WINDOW STORM COVER SYSTEMS, SUN ROOM ENCLOSURES, PATIO ENCLOSURES; ADVERTISING AND PROMOTIONAL SERVICES (U.S. CLS. 100, 101 AND 102).

CLASS 37—CONSTRUCTION AND REPAIR

FOR BUILDING CONSTRUCTION SERVICES, NAMELY, INSTALLATION AND REPAIR OF WINDOWS, SIDINGS, INSULATED SIDING, ENTRY DOORS, STORM DOORS, GARAGE DOORS, SEAMLESS GUTTERS, GUTTER LEAF PROTECTION SYSTEMS, WINDOW AWNING SYSTEMS, WINDOW DRESSINGS, WINDOW SECURITY BARS, WINDOW/GLASS FILMS, WINDOW STORM COVER SYSTEMS, SUN ROOM ENCLOSURES, AND PATIO ENCLOSURES (U.S. CLS. 100, 103 AND 106).

DAVID I, EXAMINING ATTORNEY

SN 85-447,247. EARNWELL (HK) LIMITED, KWUN TONG KOWLOON, HONG KONG, FILED 10-13-2011.

SONICBOX

THE MARK CONSISTS OF STANDARD CHARACTERS WITHOUT CLAIM TO ANY PARTICULAR FONT, STYLE, SIZE, OR COLOR.

CLASS 9—ELECTRICAL AND SCIENTIFIC APPARATUS

FOR COMPUTER SOFTWARE, NAMELY, SOFTWARE FOR DATA STORAGE, TRANSMISSION, BACKUP, RECOVERY, MANIPULATION, DISTRIBUTION AND REPLICATION; COMPUTER SOFTWARE FOR ELECTRONIC DATA MANAGEMENT, DATA SHARING, FILE UPLOADS, AND FILE DOWNLOADS (U.S. CLS. 21, 23, 26, 36 AND 38).

CLASS 39—TRANSPORTATION AND STORAGE

FOR ELECTRONIC STORAGE OF DATA, NAMELY, TEXT, DOCUMENTS, PHOTOGRAPHS, IMAGES, VIDEO, AUDIO, AND OTHER DATA PROVIDED VIA A WEBSITE, WHICH MAY BE ACCESSED OVER A GLOBAL COMPUTER NETWORK VIA A USER'S PERSONAL COMPUTER; ELECTRONIC STORAGE OF DATA, NAMELY, TEXT, DOCUMENTS, PHOTOGRAPHS, IMAGES, VIDEO, AUDIO, AND OTHER DATA (U.S. CLS. 100 AND 105).

CLASS 42—SCIENTIFIC AND COMPUTER SERVICES

FOR COMPUTER SERVICES, NAMELY, HOSTING AND MAINTAINING AN ON-LINE WEBSITE FOR OTHERS FOR STORAGE OF DATA; REMOTE ONLINE BACKUP OF COMPUTER DATA; COMPUTER SERVICES, NAMELY, HOSTING AND MAINTAINING AN ON-LINE WEB SITE FOR OTHERS TO UPLOAD AND DOWNLOAD DATA, NAMELY, TEXT, DOCUMENTS, PHOTOGRAPHS, IMAGES, VIDEO, AUDIO, AND OTHER DATA (U.S. CLS. 100 AND 101).

ANDREW RHIM, EXAMINING ATTORNEY

SN 85-447,275. MB VOGELZANG VINEYARDS, LLC, SANTA BARBARA, CA. FILED 10-13-2011.

VOGELZANG

THE MARK CONSISTS OF STANDARD CHARACTERS WITHOUT CLAIM TO ANY PARTICULAR FONT, STYLE, SIZE, OR COLOR.

OWNER OF U.S. REG. NOS. 3,466,908, 3,574,728 AND 3,602,305.

THE ENGLISH TRANSLATION OF "VOGELZANG" IN THE MARK IS "BIRD SONG".

CLASS 31—NATURAL AGRICULTURAL PRODUCTS

FOR FRESH GRAPES; FRESH GRAPES FOR WINE-MAKING; FRESH WINE GRAPES (U.S. CLS. 1 AND 46). FIRST USE 8-30-2001; IN COMMERCE 8-30-2001.

CLASS 44—MEDICAL, BEAUTY AND AGRICULTURAL SERVICES

FOR VINEYARD AND WINERY SERVICES, NAMELY, THE CULTIVATION OF GRAPES FOR OTHERS; VITICULTURE SERVICES, NAMELY, GRAPE GROWING AND CULTIVATION OF GRAPES FOR OTHERS (U.S. CLS. 100 AND 101).

FIRST USE 8-30-2001; IN COMMERCE 8-30-2001.
LEIGH CAROLINE CASE, EXAMINING ATTORNEY

SN 85-447,307. AKOO INTERNATIONAL, INC., ROSEMONT, IL. FILED 10-14-2011.

AKOOTV

THE MARK CONSISTS OF STANDARD CHARACTERS WITHOUT CLAIM TO ANY PARTICULAR FONT, STYLE, SIZE, OR COLOR.

OWNER OF U.S. REG. NO. 3,218,620.

CLASS 38—COMMUNICATION

FOR AUDIO AND VIDEO BROADCASTING SERVICES OVER THE INTERNET; BROADCAST OF CABLE TELEVISION PROGRAMMES; BROADCASTING OF TELEVISION PROGRAMMES; BROADCASTING OF VIDEO AND AUDIO PROGRAMMING OVER THE INTERNET; BROADCASTING PROGRAMS VIA A GLOBAL COMPUTER NETWORK (U.S. CLS. 100, 101 AND 104).

CLASS 41—EDUCATION AND ENTERTAINMENT

FOR ENTERTAINMENT SERVICES, NAMELY, THE PROVISION OF CONTINUING PROGRAMS, SEGMENTS, AND SHOWS FEATURING MUSIC, NEWS, COMEDY, AND COMMENTARY DELIVERED BY TELEVISION, CABLE, SATELLITE, THE INTERNET, OR OTHER COMMUNICATIONS NETWORKS (U.S. CLS. 100, 101 AND 107).

ALLISON HOLTZ, EXAMINING ATTORNEY

SN 85-447,358. PEACEVENTURES, INC., NEW YORK, NY. FILED 10-14-2011.



THE MARK CONSISTS OF THE SILHOUETTE OF A FEATHER.

CLASS 14—JEWELRY

FOR JEWELRY (U.S. CLS. 2, 27, 28 AND 50).

CLASS 18—LEATHER GOODS

FOR LEATHER ITEMS, NAMELY, HANDBAGS, WALLETS, LEATHER BUSINESS CARD CASES, BILLFOLDS, KEY CASES; TOILETRY CASES SOLD EMPTY (U.S. CLS. 1, 2, 3, 22 AND 41).

CLASS 25—CLOTHING

FOR MEN'S AND WOMEN'S APPAREL, NAMELY, SHIRTS, BLOUSES, SPORTSWEAR, NAMELY, SHIRTS, PANTS, BLAZERS, JACKETS; PAJAMAS, UNDERWEAR, SUITS, COATS, TROUSERS, JACKETS, KNITWEAR, NAMELY, SWEATERS, CARDIGANS, POLO SHIRTS, PANTS; RAINWEAR, SCARVES, NIGHT GOWNS, DRESSES, GOWNS, SKIRTS, BEACHWEAR, SWIMWEAR, NECKWEAR, ATHLETIC WEAR, NAMELY, SHIRTS, SHORTS, HEADBANDS, SWEAT SUITS; LOUNGEWEAR, GLOVES, SHOES, HATS; ACCESSORIES, NAMELY, BELTS, SOCKS, TIES AND STOCKINGS (U.S. CLS. 22 AND 39).

KAREN K. BUSH, EXAMINING ATTORNEY

SN 85-447,374. MASTERCARD INTERNATIONAL INCORPORATED, PURCHASE, NY. FILED 10-14-2011.

PRICELESS HOTEL COLLECTION

THE MARK CONSISTS OF STANDARD CHARACTERS WITHOUT CLAIM TO ANY PARTICULAR FONT, STYLE, SIZE, OR COLOR.

OWNER OF U.S. REG. NOS. 2,370,508 AND 3,675,858.

NO CLAIM IS MADE TO THE EXCLUSIVE RIGHT TO USE "HOTEL COLLECTION", APART FROM THE MARK AS SHOWN.

CLASS 36—INSURANCE AND FINANCIAL

FOR FINANCIAL SERVICES, NAMELY, PAYMENT CARD SERVICES; CREDIT CARD AND DEBIT CARD SERVICES; ELECTRONIC PAYMENTS SERVICES, NAMELY, TRANSACTION AUTHORIZATION AND SETTLEMENT SERVICES (U.S. CLS. 100, 101 AND 102).

CLASS 43—HOTEL AND RESTAURANT SERVICES

FOR PROVIDING ON-LINE BOOKING AND RESERVATION SERVICES FOR HOTELS, TEMPORARY LODGING, TEMPORARY ACCOMMODATION; TRAVEL AGENCY SERVICES, NAMELY, ARRANGING TEMPORARY ACCOMMODATION; PROVIDING TRAVEL LODGING INFORMATION SERVICES AND TRAVEL LODGING BOOKING AGENCY SERVICES FOR TRAVELERS (U.S. CLS. 100 AND 101).

DAVID MURRAY, EXAMINING ATTORNEY

SN 85-447,472. QUALMAN, ERIK, CAMBRIDGE, MA. FILED 10-14-2011.

WORLD OF MOUTH

THE MARK CONSISTS OF STANDARD CHARACTERS WITHOUT CLAIM TO ANY PARTICULAR FONT, STYLE, SIZE, OR COLOR.

CLASS 9—ELECTRICAL AND SCIENTIFIC APPARATUS

FOR DOWNLOADABLE MP3 FILES, MP3 RECORDINGS, ON-LINE DISCUSSION BOARDS, WEBCASTS, WEBINARS AND PODCASTS FEATURING MUSIC, AUDIO BOOKS IN THE FIELD OF BUSINESS, AND NEWS BROADCASTS; ELECTRONIC PUBLICATIONS, NAMELY, BOOKS IN THE FIELDS OF BUSINESS, SOCIAL MEDIA, ADVERTISING, AND MARKETING RECORDED ON COMPUTER MEDIA (U.S. CLS. 21, 23, 26, 36 AND 38).

CLASS 35—ADVERTISING AND BUSINESS

FOR ADVERTISING AND MARKETING SERVICES PROVIDED BY MEANS OF INDIRECT METHODS OF MARKETING COMMUNICATIONS, NAMELY, SOCIAL MEDIA, SEARCH ENGINE MARKETING, INQUIRY MARKETING, INTERNET MARKETING, MOBILE MARKETING, BLOGGING AND OTHER FORMS OF PASSIVE, SHARABLE OR VIRAL COMMUNICATIONS CHANNELS; ADVERTISING AND MARKETING SERVICES, NAMELY, PROMOTING THE GOODS AND SERVICES OF OTHERS (U.S. CLS. 100, 101 AND 102).

SIMON TENG, EXAMINING ATTORNEY

SN 85-447,475. VINTERNATIONAL IMPORTS, LTD., DBA CRU VIN DOGS WINE GROUP, GREENWOOD VILLAGE, CO. FILED 10-14-2011.

**CLASS 33—WINES AND SPIRITS**

FOR WINES (U.S. CLS. 47 AND 49).

CLASS 36—INSURANCE AND FINANCIAL

FOR CHARITABLE FUNDRAISING SERVICES BY MEANS OF SELLING GOODS TO RAISE FUNDS FOR LOCAL ANIMAL SHELTERS, ANIMAL RESCUE ORGANIZATION, CANINE ASSISTANCE COMPANIONS, AND ANIMAL HEALTH AND WELFARE RESEARCH; CHARITABLE FUNDRAISING SERVICES, NAMELY, BY PROVIDING INDIVIDUALS WITH THE INFORMATION AND OPPORTUNITY TO MAKE MONETARY DONATIONS TO THEIR FAVORITE CHARITY (U.S. CLS. 100, 101 AND 102).

SIMON TENG, EXAMINING ATTORNEY

SN 85-447,477. VINTERNATIONAL IMPORTS, LTD., DBA CRU VIN DOGS WINE GROUP, GREENWOOD VILLAGE, CO. FILED 10-14-2011.



OWNER OF U.S. REG. NO. 4,003,644.
NO CLAIM IS MADE TO THE EXCLUSIVE RIGHT TO USE "COMPANION" FOR CLASS 36 ONLY, APART FROM THE MARK AS SHOWN.

CLASS 33—WINES AND SPIRITS

FOR WINES (U.S. CLS. 47 AND 49).

CLASS 36—INSURANCE AND FINANCIAL

FOR CHARITABLE FUNDRAISING SERVICES BY MEANS OF SELLING GOODS TO RAISE FUNDS FOR LOCAL ANIMAL SHELTERS, ANIMAL RESCUE ORGANIZATION, CANINE ASSISTANCE COMPANIONS, AND ANIMAL HEALTH AND WELFARE RESEARCH; CHARITABLE FUNDRAISING SERVICES, NAMELY, BY PROVIDING INDIVIDUALS WITH THE INFORMATION AND OPPORTUNITY TO MAKE MONETARY DONATIONS TO THEIR FAVORITE CHARITY (U.S. CLS. 100, 101 AND 102).

SIMON TENG, EXAMINING ATTORNEY

SN 85-447,517. FLEETWOOD GRUVER, WINDERMERE, FL.
FILED 10-14-2011.

TOP 10 IN 5

THE MARK CONSISTS OF STANDARD CHARACTERS WITHOUT CLAIM TO ANY PARTICULAR FONT, STYLE, SIZE, OR COLOR.

CLASS 9—ELECTRICAL AND SCIENTIFIC APPARATUS

FOR COMPUTER APPLICATION SOFTWARE FOR MOBILE PHONES, NAMELY, SOFTWARE FOR PROVIDING, IN RESPONSE TO SPECIFIED AUDIO/VISUAL CONTENT, A VIEWER OF STREAMING AUDIO/VISUAL MUSIC, IMAGES, INFORMATION AND ENTERTAINMENT CONTENT WITH INTERNET LINKS TO RELEVANT GOODS, SERVICES OR INFORMATION, INCLUDING, ACCESS TO OTHER AUDIO/VISUAL ENTERTAINMENT, INFORMATION, RETAIL SERVICES PROVIDERS AND/OR COMPETITION; COMPUTER SOFTWARE FEATURING MUSICAL SOUND RECORDINGS AND MUSICAL VIDEO RECORDINGS; COMPUTER SOFTWARE FOR STREAMING, BROADCASTING, TRANSMITTING AND REPRODUCING MUSIC AND/OR OTHER AUDIO/VISUAL ENTERTAINMENT AND MEDIA CONTENT THAT MAY BE DOWNLOADED FROM A GLOBAL COMPUTER NETWORK; DOWNLOADABLE COMPUTER SOFTWARE FOR STREAMING, BROADCASTING, TRANSMITTING AND REPRODUCING MUSIC AND/OR OTHER AUDIO/VISUAL ENTERTAINMENT AND MEDIA CONTENT; DOWNLOADABLE SOFTWARE FOR ACCESSING INFORMATION RELATING TO MUSIC, IMAGES, ENTERTAINMENT AND AUDIO/VISUAL RECORDINGS, AND FOR SEARCHING INFORMATION FROM A GLOBAL COMPUTER NETWORK AND/OR THE INTERNET; DOWNLOADABLE SOFTWARE IN THE NATURE OF A MOBILE APPLICATION FOR PROVIDING, IN RESPONSE TO SPECIFIED AUDIO/VISUAL CONTENT, A VIEWER OF STREAMING AUDIO/VISUAL MUSIC, IMAGES, INFORMATION AND ENTERTAINMENT CONTENT WITH INTERNET LINKS TO RELEVANT GOODS, SERVICES OR INFORMATION, INCLUDING, ACCESS TO OTHER AUDIO/VISUAL ENTERTAINMENT, INFORMATION, RETAIL SERVICES PROVIDERS AND/OR COMPETITION (U.S. CLS. 21, 23, 26, 36 AND 38).

CLASS 38—COMMUNICATION

FOR STREAMING OF AUDIO MATERIAL ON THE INTERNET; STREAMING OF AUDIO, VISUAL AND AUDIOVISUAL MATERIAL VIA A GLOBAL COMPUTER NETWORK; STREAMING OF VIDEO MATERIAL ON THE INTERNET (U.S. CLS. 100, 101 AND 104).

CLASS 41—EDUCATION AND ENTERTAINMENT

FOR ENTERTAINMENT SERVICES, NAMELY, PROVIDING INFORMATION ABOUT A RECORDING ARTIST VIA AN ONLINE NETWORK; ENTERTAINMENT SERVICES, NAMELY, PROVIDING INFORMATION BY MEANS OF A GLOBAL COMPUTER NETWORK IN THE FIELDS OF CELEBRITIES, ENTERTAINMENT, AND POPULAR CULTURE; ENTERTAINMENT SERVICES, NAMELY, PROVIDING NON-DOWNLOADABLE PLAYBACK OF MUSIC VIA GLOBAL COMMUNICATIONS NETWORKS; ENTERTAINMENT SERVICES, NAMELY, PROVIDING NON-DOWNLOADABLE PRERECORDED MUSIC, INFORMATION IN THE FIELD OF MUSIC, AND COMMENTARY AND ARTICLES ABOUT MUSIC, ALL ON-LINE VIA A GLOBAL COMPUTER NETWORK; PROVIDING A WEBSITE FEATURING INFORMATION IN THE FIELD OF MUSIC AND ENTERTAINMENT; PROVIDING AN INTERNET WEBSITE PORTAL IN THE FIELD OF MUSIC; PROVIDING INFORMATION, NEWS AND COMMENTARY IN THE FIELD OF ENTERTAINMENT (U.S. CLS. 100, 101 AND 107).

MARK T. MULLEN, EXAMINING ATTORNEY

SN 85-447,531. BOTTLENOSE, INC., SAN FRANCISCO, CA.
FILED 10-14-2011.



THE MARK CONSISTS OF THE WORD "BOTTLENOSE", WITH THE SECOND "O" SHIFTED UP AND APPEARING AS SUPPORTED BY A DOLPHIN.

CLASS 9—ELECTRICAL AND SCIENTIFIC APPARATUS

FOR COMPUTER SOFTWARE WHICH FACILITATES ONLINE SERVICES FOR SOCIAL NETWORKING, BUILDING SOCIAL NETWORKING APPLICATIONS AND FOR ALLOWING DATA RETRIEVAL, UPLOAD, DOWNLOAD, ACCESS AND MANAGEMENT; COMPUTER SOFTWARE FOR TRACKING, FILTERING, AUTOMATING, MANAGING, SEARCHING, AND INTERACTING WITH SOCIAL MEDIA PLATFORMS (U.S. CLS. 21, 23, 26, 36 AND 38).

CLASS 45—PERSONAL AND LEGAL SERVICES

FOR ONLINE SOCIAL NETWORKING SERVICES PROVIDED THROUGH A WEBSITE BY TRACKING, FILTERING, AUTOMATING, MANAGING, SEARCHING, AND INTERACTING WITH OTHER SOCIAL MEDIA PLATFORMS; ONLINE SOCIAL NETWORKING SERVICES; PROVIDING ON-LINE COMPUTER DATABASES AND ON-LINE SEARCHABLE DATABASES IN THE FIELD OF SOCIAL NETWORKING (U.S. CLS. 100 AND 101).

FIRST USE 10-1-2011; IN COMMERCE 10-1-2011.
MIDGE BUTLER, EXAMINING ATTORNEY

SN 85-447,634. MARS HILL CHURCH, SEATTLE, WA. FILED 10-14-2011.

SN 85-447,663. ONE N DONE, LLC, GLENVIEW, IL. FILED 10-14-2011.

Re:Lit

THE MARK CONSISTS OF STANDARD CHARACTERS WITHOUT CLAIM TO ANY PARTICULAR FONT, STYLE, SIZE, OR COLOR.

CLASS 16—PAPER GOODS AND PRINTED MATTER

FOR PRINTED MATERIALS, NAMELY, BOOKS IN THE FIELD OF THEOLOGY (U.S. CLS. 2, 5, 22, 23, 29, 37, 38 AND 50).
FIRST USE 2-11-2008; IN COMMERCE 2-11-2008.

CLASS 41—EDUCATION AND ENTERTAINMENT

FOR BOOK PUBLISHING (U.S. CLS. 100, 101 AND 107).
FIRST USE 2-11-2008; IN COMMERCE 2-11-2008.
RONALD MCMORROW, EXAMINING ATTORNEY

SN 85-447,653. BRAINSTORMIN' PRODUCTIONS INC., RIVERSIDE, CT. FILED 10-14-2011.

BRAINSTORMIN' PRODUCTIONS

THE MARK CONSISTS OF STANDARD CHARACTERS WITHOUT CLAIM TO ANY PARTICULAR FONT, STYLE, SIZE, OR COLOR.

NO CLAIM IS MADE TO THE EXCLUSIVE RIGHT TO USE "PRODUCTIONS", APART FROM THE MARK AS SHOWN.

CLASS 35—ADVERTISING AND BUSINESS

FOR EMPLOYMENT SERVICES IN THE NATURE OF TALENT CASTING IN THE FIELD(S) OF PROMOTIONAL EVENTS, PRODUCT LAUNCHES, AND COMMERCIAL, TELEVISION, AND FILM VOICE-OVERS (U.S. CLS. 100, 101 AND 102).
FIRST USE 1-0-2008; IN COMMERCE 1-0-2008.

CLASS 41—EDUCATION AND ENTERTAINMENT

FOR ENTERTAINMENT, NAMELY, PRODUCTION OF SPORTS DOCUMENTARIES AND INSPIRATIONAL STORIES FOR ENTERTAINMENT SPORTS NETWORKS (U.S. CLS. 100, 101 AND 107).
FIRST USE 1-0-2008; IN COMMERCE 1-0-2008.
LINDA ESTRADA, EXAMINING ATTORNEY

ONE N DONE

THE MARK CONSISTS OF STANDARD CHARACTERS WITHOUT CLAIM TO ANY PARTICULAR FONT, STYLE, SIZE, OR COLOR.

CLASS 25—CLOTHING

FOR GOLF SHIRTS; HATS; POLO SHIRTS; SHIRTS; SHIRTS AND SHORT-SLEEVED SHIRTS; SWEAT SHIRTS; T-SHIRTS; TANK TOPS (U.S. CLS. 22 AND 39).
FIRST USE 9-1-2011; IN COMMERCE 9-1-2011.

CLASS 35—ADVERTISING AND BUSINESS

FOR ON-LINE RETAIL STORE SERVICES FEATURING CLOTHING AND APPAREL; RETAIL STORE AND ON-LINE RETAIL STORE SERVICES FEATURING CLOTHING AND APPAREL (U.S. CLS. 100, 101 AND 102).
LINDA MICKLEBURGH, EXAMINING ATTORNEY

SN 85-447,665. SOCIETE DES PRODUITS NESTLE S.A., 1800 VEVEY, SWITZERLAND, FILED 10-14-2011.

FEEL LIKE NEW. FEEL LIKE YOU.

THE MARK CONSISTS OF STANDARD CHARACTERS WITHOUT CLAIM TO ANY PARTICULAR FONT, STYLE, SIZE, OR COLOR.

CLASS 9—ELECTRICAL AND SCIENTIFIC APPARATUS

FOR PRE-RECORDED CDS AND DVDS ABOUT WEIGHT CONTROL, NUTRITION AND MENU PLANNING AND THE LIKE (U.S. CLS. 21, 23, 26, 36 AND 38).

CLASS 16—PAPER GOODS AND PRINTED MATTER

FOR WORKBOOKS AND PRINTED GUIDES ABOUT WEIGHT CONTROL, NUTRITION, AND MENU PLANNING AND THE LIKE (U.S. CLS. 2, 5, 22, 23, 29, 37, 38 AND 50).

CLASS 44—MEDICAL, BEAUTY AND AGRICULTURAL SERVICES

FOR WEIGHT REDUCTION DIET PLANNING AND NUTRITION SUPERVISION SERVICES, NUTRITIONAL COUNSELING SERVICES (U.S. CLS. 100 AND 101).
DAVID TAYLOR, EXAMINING ATTORNEY

SN 85-447,674. ROOK COFFEE ROASTERS HOLDINGS LLC, DBA ROOK COFFEE ROASTERS OR ROOK COFFEE OR ROOK ROASTERS, OAKHURST, NJ. FILED 10-14-2011.



THE COLOR(S) WHITE AND BLACK IS/ARE CLAIMED AS A FEATURE OF THE MARK.

THE MARK CONSISTS OF A BLACK IMAGE OF A ROOK (CROW) AGAINST A WHITE BACKGROUND EMBODIED IN A BLACK CIRCLE.

CLASS 16—PAPER GOODS AND PRINTED MATTER

FOR STICKERS (U.S. CLS. 2, 5, 22, 23, 29, 37, 38 AND 50).
FIRST USE 1-1-2010; IN COMMERCE 1-1-2010.

CLASS 25—CLOTHING

FOR BABY BODYSUITS; HATS; HOODED SWEATSHIRTS; LONG-SLEEVED SHIRTS; SHIRTS FOR INFANTS, BABIES, TODDLERS AND CHILDREN; SWEATSHIRTS; T-SHIRTS (U.S. CLS. 22 AND 39).
FIRST USE 1-1-2010; IN COMMERCE 1-1-2010.

CLASS 30—STAPLE FOODS

FOR COFFEE; COFFEE BASED BEVERAGES; COFFEE BEANS; ROASTED COFFEE BEANS (U.S. CL. 46).
FIRST USE 1-1-2010; IN COMMERCE 1-1-2010.
RAUL CORDOVA, EXAMINING ATTORNEY

SN 85-447,709. KINGSMARK PRIVATE FINANCIAL ADVISORS, LLC, ALBANY, GA. FILED 10-14-2011.

KINGSMARK

THE MARK CONSISTS OF STANDARD CHARACTERS WITHOUT CLAIM TO ANY PARTICULAR FONT, STYLE, SIZE, OR COLOR.

CLASS 35—ADVERTISING AND BUSINESS

FOR ACCOUNTING SERVICES; TAX CONSULTATION, ADVISORY, AND PREPARATION SERVICES; AND TAX AND TAXATION PLANNING, ADVICE, INFORMATION AND CONSULTANCY SERVICES (U.S. CLS. 100, 101 AND 102).
FIRST USE 8-1-2011; IN COMMERCE 8-1-2011.

CLASS 36—INSURANCE AND FINANCIAL

FOR SECURITIES BROKERAGE; INVESTMENT ADVICE; INSURANCE BROKERAGE; INSURANCE CONSULTANCY; MUTUAL FUND INVESTMENT AND DISTRIBUTION SERVICES; FINANCIAL ASSET MANAGEMENT; CAPITAL INVESTMENT SERVICES AND CONSULTING; FINANCIAL AND INVESTMENT SERVICES, NAMELY, ASSET ACQUISITION, CONSULTATION, DEVELOPMENT AND MANAGEMENT SERVICES, MANAGEMENT AND BROKERAGE IN THE FIELDS OF STOCKS, BONDS, OPTIONS, COMMODITIES, FUTURES AND OTHER SECURITIES, AND THE INVESTMENT OF FUNDS OF OTHERS; FINANCIAL PLANNING AND INVESTMENT ADVISORY SERVICES; FINANCIAL PLANNING FOR RETIREMENT; ESTATE PLANNING (U.S. CLS. 100, 101 AND 102).
FIRST USE 8-1-2011; IN COMMERCE 8-1-2011.
VERNA BETH RIRIE, EXAMINING ATTORNEY

SN 85-447,713. KINGSMARK PRIVATE FINANCIAL ADVISORS, LLC, ALBANY, GA. FILED 10-14-2011.



THE MARK CONSISTS OF A STYLIZED INVERTED V-SHAPE ABOVE A STYLIZED VERTICAL LINE TOGETHER WITH THE STYLIZED WORDING "KINGSMARK".

CLASS 35—ADVERTISING AND BUSINESS

FOR ACCOUNTING SERVICES; TAX CONSULTATION, ADVISORY, AND PREPARATION SERVICES; AND TAX AND TAXATION PLANNING, ADVICE, INFORMATION AND CONSULTANCY SERVICES (U.S. CLS. 100, 101 AND 102).
FIRST USE 8-1-2011; IN COMMERCE 8-1-2011.

CLASS 36—INSURANCE AND FINANCIAL

FOR SECURITIES BROKERAGE; INVESTMENT ADVICE; INSURANCE BROKERAGE; INSURANCE CONSULTANCY; MUTUAL FUND INVESTMENT AND DISTRIBUTION SERVICES; FINANCIAL ASSET MANAGEMENT; CAPITAL INVESTMENT SERVICES AND CONSULTING; FINANCIAL AND INVESTMENT SERVICES, NAMELY, ASSET ACQUISITION, CONSULTATION, DEVELOPMENT AND MANAGEMENT SERVICES, MANAGEMENT AND BROKERAGE IN THE FIELDS OF STOCKS, BONDS, OPTIONS, COMMODITIES, FUTURES AND OTHER SECURITIES, AND THE INVESTMENT OF FUNDS OF OTHERS; FINANCIAL PLANNING AND INVESTMENT ADVISORY SERVICES; FINANCIAL PLANNING FOR RETIREMENT; ESTATE PLANNING (U.S. CLS. 100, 101 AND 102).
FIRST USE 8-1-2011; IN COMMERCE 8-1-2011.
VERNA BETH RIRIE, EXAMINING ATTORNEY

SN 85-447,714. KINGSMARK PRIVATE FINANCIAL ADVISORS, LLC, ALBANY, GA. FILED 10-14-2011.

SN 85-447,738. KAHUA, INC., ALPHARETTA, GA. FILED 10-14-2011.

CAREFULLY CHOSEN
STRATEGIES.

KSTORE

THE MARK CONSISTS OF STANDARD CHARACTERS WITHOUT CLAIM TO ANY PARTICULAR FONT, STYLE, SIZE, OR COLOR.

THE MARK CONSISTS OF STANDARD CHARACTERS WITHOUT CLAIM TO ANY PARTICULAR FONT, STYLE, SIZE, OR COLOR.

CLASS 35—ADVERTISING AND BUSINESS

FOR ACCOUNTING SERVICES; TAX CONSULTATION, ADVISORY, AND PREPARATION SERVICES; AND TAX AND TAXATION PLANNING, ADVICE, INFORMATION AND CONSULTANCY SERVICES (U.S. CLS. 100, 101 AND 102).

FIRST USE 8-1-2011; IN COMMERCE 8-1-2011.

CLASS 35—ADVERTISING AND BUSINESS

FOR ON-LINE RETAIL STORE SERVICES FEATURING SOFTWARE APPLICATIONS; BUSINESS MANAGEMENT OF ON-LINE SOFTWARE PLATFORMS AND ON-LINE MARKETPLACES (U.S. CLS. 100, 101 AND 102).

CLASS 36—INSURANCE AND FINANCIAL

FOR SECURITIES BROKERAGE; INVESTMENT ADVICE; INSURANCE BROKERAGE; INSURANCE CONSULTANCY; MUTUAL FUND INVESTMENT AND DISTRIBUTION SERVICES; FINANCIAL ASSET MANAGEMENT; CAPITAL INVESTMENT SERVICES AND CONSULTING; FINANCIAL AND INVESTMENT SERVICES, NAMELY, ASSET ACQUISITION, CONSULTATION, DEVELOPMENT AND MANAGEMENT SERVICES, MANAGEMENT AND BROKERAGE IN THE FIELDS OF STOCKS, BONDS, OPTIONS, COMMODITIES, FUTURES AND OTHER SECURITIES, AND THE INVESTMENT OF FUNDS OF OTHERS; FINANCIAL PLANNING AND INVESTMENT ADVISORY SERVICES; FINANCIAL PLANNING FOR RETIREMENT; ESTATE PLANNING (U.S. CLS. 100, 101 AND 102).

FIRST USE 8-1-2011; IN COMMERCE 8-1-2011.

VERNA BETH RIRIE, EXAMINING ATTORNEY

CLASS 42—SCIENTIFIC AND COMPUTER SERVICES

FOR SOFTWARE AS A SERVICE (SAAS) SERVICES, NAMELY, HOSTING AND MANAGING ONLINE SOFTWARE FOR OTHERS THAT ENABLES SHARING AND DISTRIBUTION OF SOFTWARE APPLICATIONS (U.S. CLS. 100 AND 101).

DANNEAN HETZEL, EXAMINING ATTORNEY

SN 85-447,745. KAHUA, INC., ALPHARETTA, GA. FILED 10-14-2011.

SN 85-447,727. 29TH STREET BEVERAGE COMPANY, MISSISSAUGA, ONTARIO, CANADA, FILED 10-14-2011.

ONE BUCK CHUCK

K2K

THE MARK CONSISTS OF STANDARD CHARACTERS WITHOUT CLAIM TO ANY PARTICULAR FONT, STYLE, SIZE, OR COLOR.

THE MARK CONSISTS OF STANDARD CHARACTERS WITHOUT CLAIM TO ANY PARTICULAR FONT, STYLE, SIZE, OR COLOR.

CLASS 32—LIGHT BEVERAGES

FOR BEER; MALT BEER (U.S. CLS. 45, 46 AND 48).

CLASS 35—ADVERTISING AND BUSINESS

FOR BUSINESS COLLABORATION SERVICES, NAMELY, PROVIDING AN ON-LINE SOFTWARE PLATFORM THAT ENABLES AND PROMOTES COLLABORATION AMONGST USERS (U.S. CLS. 100, 101 AND 102).

CLASS 33—WINES AND SPIRITS

FOR DISTILLED SPIRITS; FLAVORED BREWED MALT BEVERAGE (U.S. CLS. 47 AND 49).

VERNA BETH RIRIE, EXAMINING ATTORNEY

CLASS 42—SCIENTIFIC AND COMPUTER SERVICES

FOR PROVIDING TEMPORARY USE OF ON-LINE, NON-DOWNLOADABLE COMPUTER SOFTWARE COLLABORATION TOOLS AND ON-LINE DATABASES; SOFTWARE AS A SERVICE (SAAS) SERVICES, NAMELY, HOSTING AND MANAGING ONLINE SOFTWARE FOR OTHERS THAT ENABLES USE AND SHARING OF DATA, INFORMATION, ELECTRONIC DOCUMENTS, AND SOFTWARE APPLICATIONS (U.S. CLS. 100 AND 101).

DANNEAN HETZEL, EXAMINING ATTORNEY

SN 85-447,774. CHORI CO., LTD., CHUO-KU, OSAKA, JAPAN, FILED 10-14-2011.



THE MARK CONSISTS OF THE LETTERS "DAI" ABOVE TWO CHINESE CHARACTERS, WHICH ARE ABOVE THE LETTERS "CHI", WITH A LINE ABOVE "DAI" AND A LINE BELOW "CHI", SURROUNDED BY A SQUARE.

THE ENGLISH TRANSLATION OF "DAI CHI" IN THE MARK IS "EARTH".

THE NON-LATIN CHARACTERS IN THE MARK TRANSLITERATE TO "DAI CHI" AND THIS MEANS EARTH IN ENGLISH.

CLASS 23—YARNS AND THREADS

FOR THREADS AND YARNS FOR TEXTILE USE (U.S. CL. 43).

CLASS 24—FABRICS

FOR WOVEN FABRICS; KNITTED FABRICS; FELTS AND NON-WOVEN TEXTILE FABRICS (U.S. CLS. 42 AND 50).

CLASS 25—CLOTHING

FOR CLOTHING, NAMELY, SHIRTS, SWEATERS, JACKETS, COATS, AND SCARVES (U.S. CLS. 22 AND 39).

KEVIN CORWIN, EXAMINING ATTORNEY

SN 85-447,823. TELINEAGE, INC., DBA PINDROP SECURITY, ATLANTA, GA. FILED 10-14-2011.

PINDROP SECURITY

THE MARK CONSISTS OF STANDARD CHARACTERS WITHOUT CLAIM TO ANY PARTICULAR FONT, STYLE, SIZE, OR COLOR.

NO CLAIM IS MADE TO THE EXCLUSIVE RIGHT TO USE "SECURITY", APART FROM THE MARK AS SHOWN.

CLASS 9—ELECTRICAL AND SCIENTIFIC APPARATUS

FOR COMPUTER SOFTWARE FOR AUTHENTICATION AND/OR FRAUD PREVENTION FOR PHONE CALLS; COMPUTER SOFTWARE FOR ENCRYPTION AND DECRYPTION; COMPUTER SOFTWARE PLATFORMS FOR AUTHENTICATION AND/OR FRAUD PREVENTION FOR PHONE CALLS; COMPUTER TELEPHONY SOFTWARE FOR AUTHENTICATION AND/OR FRAUD PREVENTION FOR PHONE CALLS; COMPUTER SOFTWARE THAT PROVIDES WEB-BASED ACCESS TO APPLICATIONS AND SERVICES THROUGH A WEB OPERATING SYSTEM OR PORTAL INTERFACE; DOWNLOADABLE COMPUTER SOFTWARE FOR USE IN AUTHENTICATION AND/OR FRAUD PREVENTION FOR PHONE CALLS (U.S. CLS. 21, 23, 26, 36 AND 38).

CLASS 42—SCIENTIFIC AND COMPUTER SERVICES

FOR CLOUD COMPUTING FEATURING SOFTWARE FOR USE IN AUTHENTICATION AND/OR FRAUD PREVENTION FOR PHONE CALLS; APPLICATION SERVICE PROVIDER FEATURING APPLICATION PROGRAMMING INTERFACE (API) SOFTWARE FOR AUTHENTICATION AND/OR FRAUD PREVENTION FOR PHONE CALLS; SOFTWARE AS A SERVICE (SAAS) SERVICES FEATURING SOFTWARE IN THE FIELD OF AUTHENTICATION AND/OR FRAUD PREVENTION FOR PHONE CALLS (U.S. CLS. 100 AND 101).

ALYSSA STEEL, EXAMINING ATTORNEY

SN 85-447,853. GT SOFTWARE, INC., ATLANTA, GA. FILED 10-14-2011.

IT'S POSSIBLE

THE MARK CONSISTS OF STANDARD CHARACTERS WITHOUT CLAIM TO ANY PARTICULAR FONT, STYLE, SIZE, OR COLOR.

CLASS 9—ELECTRICAL AND SCIENTIFIC APPARATUS

FOR SOFTWARE FOR INTEGRATING AND CONVERTING MAINFRAME AND MID-RANGE LEGACY USER INTERFACES INTO GRAPHICALLY INTUITIVE WEB-BASED INTERFACES; SOFTWARE FOR PROVIDING OPEN DEVELOPMENT AND EXECUTION SOFTWARE INTERFACES TO WEB-BASED APPLICATIONS; SOFTWARE FOR CREATING, DEPLOYING AND EXECUTING WEB SERVICES FROM EXISTING SOFTWARE APPLICATIONS AND BUSINESS PROCESSES WITHOUT REQUIRING COMPUTER PROGRAMMING; SOFTWARE FOR EXTENDING ACCESS TO MAINFRAME APPLICATIONS, DATA AND PROCESS THROUGH WEB SERVICES; SOFTWARE FOR UNLOCKING INFORMATION STORED IN MAINFRAME DATA SOURCES THROUGH SYSTEM QUERY LOGIC (SQL) BASED OR WEB SERVICES-BASED ACCESS FOR DATA-CENTRIC MAINFRAME INTEGRATION; SOFTWARE FOR PROVIDING STANDARD BROWSER INTERFACES FOR MAINFRAME ACCESS; SOFTWARE FOR GENERATING SCREENS FOR BUILDING, EDITING AND MAINTAINING BASIC MAPPING SUPPORT (BMS) MAPS; SOFTWARE FOR CREATING AND MAINTAINING HELP SYSTEMS (U.S. CLS. 21, 23, 26, 36 AND 38).

CLASS 42—SCIENTIFIC AND COMPUTER SERVICES

FOR PROVIDING TEMPORARY USE OF ON-LINE, NON-DOWNLOADABLE SOFTWARE; FOR CONVERTING MAINFRAME AND MID-RANGE LEGACY USER INTERFACES INTO GRAPHICALLY INTUITIVE WEB-BASED INTERFACES; FOR INTEGRATING AND CONVERTING MAINFRAME AND MID-RANGE LEGACY USER INTERFACES INTO GRAPHICALLY INTUITIVE WEB-BASED INTERFACES; FOR PROVIDING OPEN DEVELOPMENT AND EXECUTION SOFTWARE INTERFACES TO WEB-BASED APPLICATIONS; FOR CREATING, DEPLOYING AND EXECUTING WEB SERVICES FROM EXISTING SOFTWARE APPLICATIONS AND BUSINESS PROCESSES WITHOUT REQUIRING COMPUTER PROGRAMMING; FOR EXTENDING ACCESS TO MAINFRAME APPLICATIONS, DATA AND PROCESS THROUGH WEB SERVICES; FOR UNLOCKING INFORMATION STORED IN MAINFRAME DATA SOURCES THROUGH SYSTEM QUERY LOGIC (SQL) BASED OR WEB SERVICES-BASED ACCESS FOR DATA-CENTRIC MAINFRAME INTEGRATION; FOR PROVIDING STANDARD BROWSER INTERFACES FOR MAINFRAME ACCESS; FOR GENERATING SCREENS FOR BUILDING, EDITING AND MAINTAINING BASIC MAPPING SUPPORT (BMS) MAPS; FOR CREATING AND MAINTAINING HELP SYSTEMS (U.S. CLS. 100 AND 101).

KIMBERLY FRYE, EXAMINING ATTORNEY

SN 85-447,896. SHURTAPE TECHNOLOGIES, LLC, HICKORY, NC. FILED 10-14-2011.

GOOD TO THE CORE

THE MARK CONSISTS OF STANDARD CHARACTERS WITHOUT CLAIM TO ANY PARTICULAR FONT, STYLE, SIZE, OR COLOR.

CLASS 16—PAPER GOODS AND PRINTED MATTER

FOR ADHESIVE PRESSURE SENSITIVE TAPE FOR STATIONERY OR HOUSEHOLD PURPOSES (U.S. CLS. 2, 5, 22, 23, 29, 37, 38 AND 50).

CLASS 17—RUBBER GOODS

FOR ADHESIVE PRESSURE SENSITIVE TAPE FOR COMMERCIAL AND INDUSTRIAL USES (U.S. CLS. 1, 5, 12, 13, 35 AND 50).

GEORGE LORENZO, EXAMINING ATTORNEY

SN 85-447,897. TEMPLE OF DIANA, INC., HOLLANDALE, WI. FILED 10-14-2011.

TEMPLE OF DIANA

THE MARK CONSISTS OF STANDARD CHARACTERS WITHOUT CLAIM TO ANY PARTICULAR FONT, STYLE, SIZE, OR COLOR.

CLASS 41—EDUCATION AND ENTERTAINMENT

FOR EDUCATION SERVICES, NAMELY, PROVIDING WORKSHOPS IN THE FIELD OF RELIGION AND SPIRITUALITY (U.S. CLS. 100, 101 AND 107).

FIRST USE 0-0-2001; IN COMMERCE 0-0-2001.

CLASS 45—PERSONAL AND LEGAL SERVICES

FOR CONDUCTING RELIGIOUS PRAYER SERVICES; RELIGIOUS AND SPIRITUAL SERVICES, NAMELY, PROVIDING GATHERINGS AND RETREATS TO DEVELOP AND ENHANCE THE SPIRITUAL LIVES OF INDIVIDUALS; RELIGIOUS SERVICES, NAMELY, PRAYER MEETINGS (U.S. CLS. 100 AND 101).

FIRST USE 0-0-2001; IN COMMERCE 0-0-2001.

JORDAN BAKER, EXAMINING ATTORNEY

SN 85-447,917. MOUNTAIN HARDWEAR, INC., PORTLAND, OR. FILED 10-14-2011.

Q.SHIELD

THE MARK CONSISTS OF STANDARD CHARACTERS WITHOUT CLAIM TO ANY PARTICULAR FONT, STYLE, SIZE, OR COLOR.

CLASS 9—ELECTRICAL AND SCIENTIFIC APPARATUS

FOR BIVOUCAC SACKS, NAMELY, WIND AND WATER RESISTANT BAGS INTO WHICH A PERSON CAN FIT TO PROTECT THEMSELVES FROM EXPOSURE TO THE ELEMENTS (U.S. CLS. 21, 23, 26, 36 AND 38).

CLASS 18—LEATHER GOODS

FOR BACKPACKS; CARRY-ALL BAGS; DUFFEL BAGS (U.S. CLS. 1, 2, 3, 22 AND 41).

CLASS 20—FURNITURE AND ARTICLES NOT OTHERWISE CLASSIFIED

FOR SLEEPING BAGS (U.S. CLS. 2, 13, 22, 25, 32 AND 50).

CLASS 22—CORDAGE AND FIBERS

FOR TENTS (U.S. CLS. 1, 2, 7, 19, 22, 42 AND 50).

CLASS 25—CLOTHING

FOR BALACLAVAS; BELTS; BOOTIES; GAITERS; GLOVES; HEADWEAR; JACKETS; KILTS; MITTENS; NECK GAITERS; PANTS; PARKAS; RAINWEAR; SHIRTS; SHORTS; SKI BIBS; SKI WEAR; SKIRTS; SKORTS; THERMAL UNDERWEAR; TIGHTS; TOPS; VESTS (U.S. CLS. 22 AND 39).

JOHN DALIER, EXAMINING ATTORNEY

SN 85-447,932. TRAVELCLICK INC., SCHAUMBURG, IL.
FILED 10-14-2011.

AGENCY360

THE MARK CONSISTS OF STANDARD CHARACTERS WITHOUT CLAIM TO ANY PARTICULAR FONT, STYLE, SIZE, OR COLOR.

CLASS 35—ADVERTISING AND BUSINESS

FOR PROVIDING BUSINESS AND MARKETING INFORMATION IN THE FIELDS OF HOTELS AND TRAVEL VIA A GLOBAL COMPUTER NETWORK; COLLECTION, PREPARATION, COMPOSITION, PROCESSING, ACQUISITION AND PROVISION OF BUSINESS INFORMATION, DATA, STATISTICS AND INDICES IN CONNECTION WITH HOTELS AND THE HOTEL AND TRAVEL INDUSTRIES; PROVIDING STATISTICAL INFORMATION, NAMELY, PROVIDING TRAVEL INDUSTRY AND HOTEL-RELATED FINANCIAL AND REVENUE STATISTICS TO THE TRAVEL AND HOTEL INDUSTRIES VIA A GLOBAL COMPUTER NETWORK (U.S. CLS. 100, 101 AND 102).

CLASS 39—TRANSPORTATION AND STORAGE

FOR ELECTRONIC STORAGE OF INFORMATION AND DATA IN CONNECTION WITH HOTELS AND THE HOTEL AND TRAVEL INDUSTRIES (U.S. CLS. 100 AND 105).

RAUL CORDOVA, EXAMINING ATTORNEY

SN 85-447,969. ROBERTS, TRICIA, DUNLAP, IA. FILED 10-14-2011.

STUPID BOOBIES

THE MARK CONSISTS OF STANDARD CHARACTERS WITHOUT CLAIM TO ANY PARTICULAR FONT, STYLE, SIZE, OR COLOR.

CLASS 14—JEWELRY

FOR JEWELRY (U.S. CLS. 2, 27, 28 AND 50).

CLASS 25—CLOTHING

FOR CLOTHING, WEARING APPAREL AND ACCESSORIES, NAMELY, SHIRTS, SWEATSHIRTS, T-SHIRTS, JERSEYS, SWEATERS, CARDIGANS, TANK TOPS, HALTER TOPS, PANTS, SWEAT PANTS, SHORTS; LADIES' AND MEN'S UNDERWEAR NAMELY: BRIEFS, BOXER SHORTS, BOY SHORTS, THONGS, G-STRINGS, BRAS, TEDDIES, SLIPS, GARTER BELTS, SARONGS; SLEEPWEAR, NAMELY: BATHROBES, NIGHT SHIRTS, PAJAMAS, SLEEPING GOWNS; KIMONOS; COATS, JACKETS, VESTS, DRESSES, SKIRTS, BLOUSES, ROMPERS, SWIMWEAR; RAINWEAR, NAMELY: RAINCOATS, RAIN BONNETS, RAIN BOOTS, AND RAIN CAPES; TIES, ASCOTS, BELTS, SCARVES; FOOTWEAR, NAMELY: SHOES, BOOTS, SLIPPERS, SANDALS SOCKS, TIGHTS AND STOCKINGS; HEADWEAR, NAMELY: HATS, VISORS, AND CAPS; APRONS; EAR MUFFS; BELTS; WRISTBANDS; BANDANAS (U.S. CLS. 22 AND 39).

CLASS 36—INSURANCE AND FINANCIAL

FOR CHARITABLE FUNDRAISING SERVICES (U.S. CLS. 100, 101 AND 102).

CLASS 44—MEDICAL, BEAUTY AND AGRICULTURAL SERVICES

FOR PROVIDING A WEBSITE VIA A GLOBAL COMPUTER NETWORK FEATURING INFORMATION IN THE FIELDS OF BREAST CANCER AWARENESS AND PREVENTION (U.S. CLS. 100 AND 101).

GIANCARLO CASTRO, EXAMINING ATTORNEY

SN 85-447,982. PLAYLORE LLC, DBA PLAYLORE GAMES, WESTPORT, CT. FILED 10-14-2011.

SOCCER TOWN

THE MARK CONSISTS OF STANDARD CHARACTERS WITHOUT CLAIM TO ANY PARTICULAR FONT, STYLE, SIZE, OR COLOR.

NO CLAIM IS MADE TO THE EXCLUSIVE RIGHT TO USE "SOCCER", APART FROM THE MARK AS SHOWN.

CLASS 9—ELECTRICAL AND SCIENTIFIC APPARATUS

FOR COMPUTER AND ELECTRONIC GAME SOFTWARE; DOWNLOADABLE SOFTWARE FOR PLAYING COMPUTER AND ELECTRONIC GAMES ON WIRELESS DEVICES AND COMPUTERS (U.S. CLS. 21, 23, 26, 36 AND 38).

CLASS 41—EDUCATION AND ENTERTAINMENT

FOR ENTERTAINMENT SERVICES, NAMELY, PROVIDING ONLINE COMPUTER AND ELECTRONIC GAMES (U.S. CLS. 100, 101 AND 107).

LINDA LAVACHE, EXAMINING ATTORNEY

SN 85-447,985. LABONVILLE INC., GORHAM, NH. FILED 10-14-2011.

LABONVILLE

THE MARK CONSISTS OF STANDARD CHARACTERS WITHOUT CLAIM TO ANY PARTICULAR FONT, STYLE, SIZE, OR COLOR.

THE NAME(S), PORTRAIT(S), AND/OR SIGNATURE(S) SHOWN IN THE MARK IDENTIFIES "RICHARD LABONVILLE", WHOSE CONSENT(S) TO REGISTER IS MADE OF RECORD.

SEC. 2(F).

CLASS 8—HAND TOOLS

FOR TOOL BELTS; TOOL POUCHES FOR ATTACHMENT TO TOOL BELTS (U.S. CLS. 23, 28 AND 44).

FIRST USE 1-1-1973; IN COMMERCE 1-1-1973.

CLASS 9—ELECTRICAL AND SCIENTIFIC APPARATUS

FOR CLOTHING FOR PROTECTION AGAINST ACCIDENTS; EYEWEAR; PROTECTIVE EAR COVERINGS; PROTECTIVE EYEWEAR; PROTECTIVE FACE-SHIELDS FOR PROTECTIVE HELMETS; PROTECTIVE GLASSES; PROTECTIVE HELMETS; PROTECTIVE INDUSTRIAL BOOTS; PROTECTIVE WORK GLOVES; REFLECTIVE AND ILLUMINATED CLOTHING FOR SAFETY PURPOSES (U.S. CLS. 21, 23, 26, 36 AND 38).

FIRST USE 1-1-1973; IN COMMERCE 1-1-1973.

CLASS 25—CLOTHING

FOR BIB OVERALLS; BOOTS; CHAPS; HATS; HOODS; JACKETS; PANTS; SCARVES; SUSPENDERS; SWEAT-SHIRTS; TEE SHIRTS; VESTS; WEARABLE GARMENTS AND CLOTHING, NAMELY, SHIRTS (U.S. CLS. 22 AND 39).

FIRST USE 1-1-1973; IN COMMERCE 1-1-1973.

CLASS 35—ADVERTISING AND BUSINESS

FOR RETAIL STORE AND ON-LINE RETAIL STORE SERVICES FEATURING CLOTHING, PROTECTIVE GEAR AND SAFETY GEAR AND SIGNS (U.S. CLS. 100, 101 AND 102).

FIRST USE 1-1-1973; IN COMMERCE 1-1-1973.

STEVEN JACKSON, EXAMINING ATTORNEY

SN 85-448,002. ROBERTS, TRICIA, DUNLAP, IA. FILED 10-14-2011.

CHECK THE GIRLS

THE MARK CONSISTS OF STANDARD CHARACTERS WITHOUT CLAIM TO ANY PARTICULAR FONT, STYLE, SIZE, OR COLOR.

CLASS 14—JEWELRY

FOR JEWELRY (U.S. CLS. 2, 27, 28 AND 50).

CLASS 25—CLOTHING

FOR CLOTHING, WEARING APPAREL AND ACCESSORIES, NAMELY, SHIRTS, SWEATSHIRTS, T-SHIRTS, JERSEYS, SWEATERS, CARDIGANS, TANK TOPS, HALTER TOPS, PANTS, SWEAT PANTS, SHORTS; LADIES' AND MEN'S UNDERWEAR NAMELY: BRIEFS, BOXER SHORTS, BOY SHORTS, THONGS, G-STRINGS, BRAS, TEDDIES, SLIPS, GARTER BELTS, SARONGS; SLEEPWEAR, NAMELY: BATHROBES, NIGHT SHIRTS, PAJAMAS, SLEEPING GOWNS; KIMONOS; COATS, JACKETS, VESTS, DRESSES, SKIRTS, BLOUSES, ROMPERS, SWIMWEAR; RAINWEAR, NAMELY: RAINCOATS, RAIN BONNETS, RAIN BOOTS, AND RAIN CAPES; TIES, ASCOTS, BELTS, SCARVES; FOOTWEAR, NAMELY: SHOES, BOOTS, SLIPPERS, SANDALS SOCKS, TIGHTS AND STOCKINGS; HEADWEAR, NAMELY: HATS, VISORS, AND CAPS; APRONS; EAR MUFFS; BELTS; WRISTBANDS; BANDANAS (U.S. CLS. 22 AND 39).

CLASS 36—INSURANCE AND FINANCIAL

FOR CHARITABLE FUNDRAISING SERVICES (U.S. CLS. 100, 101 AND 102).

CLASS 44—MEDICAL, BEAUTY AND AGRICULTURAL SERVICES

FOR PROVIDING A WEBSITE VIA A GLOBAL COMPUTER NETWORK FEATURING INFORMATION IN THE FIELDS OF BREAST CANCER AWARENESS AND PREVENTION (U.S. CLS. 100 AND 101).

GIANCARLO CASTRO, EXAMINING ATTORNEY

SN 85-448,037. HITACHI CONSULTING CORPORATION, DALLAS, TX. FILED 10-14-2011.

HFUSION

THE MARK CONSISTS OF STANDARD CHARACTERS WITHOUT CLAIM TO ANY PARTICULAR FONT, STYLE, SIZE, OR COLOR.

CLASS 35—ADVERTISING AND BUSINESS

FOR BUSINESS MANAGEMENT, ADVISORY AND CONSULTATION SERVICES; BUSINESS CONSULTATION SERVICES, NAMELY, PROVIDING TOOLS AND METHODOLOGIES FOR PROJECT MANAGEMENT, BUSINESS TRANSFORMATION, AND COMPUTER SYSTEMS AND SOFTWARE IMPLEMENTATION (U.S. CLS. 100, 101 AND 102).

FIRST USE 7-22-2010; IN COMMERCE 7-22-2010.

CLASS 42—SCIENTIFIC AND COMPUTER SERVICES

FOR COMPUTER CONSULTATION IN THE FIELDS OF PROJECT MANAGEMENT, BUSINESS TRANSFORMATION, AND COMPUTER SYSTEMS AND SOFTWARE IMPLEMENTATION (U.S. CLS. 100 AND 101).

FIRST USE 7-22-2010; IN COMMERCE 7-22-2010.

STEPHANIE ALI, EXAMINING ATTORNEY

SN 85-448,039. CASCIOLI, KENNETH DANIEL, HARTSDALE, NY. FILED 10-14-2011.

handsome money

THE MARK CONSISTS OF STANDARD CHARACTERS WITHOUT CLAIM TO ANY PARTICULAR FONT, STYLE, SIZE, OR COLOR.

CLASS 9—ELECTRICAL AND SCIENTIFIC APPARATUS

FOR SOUND RECORDINGS FEATURING MUSIC (U.S. CLS. 21, 23, 26, 36 AND 38).

CLASS 25—CLOTHING

FOR HATS; T-SHIRTS (U.S. CLS. 22 AND 39).

CLASS 41—EDUCATION AND ENTERTAINMENT

FOR ENTERTAINMENT SERVICES IN THE NATURE OF LIVE MUSICAL PERFORMANCES; MUSIC PRODUCTION SERVICES (U.S. CLS. 100, 101 AND 107).
STEPHANIE ALI, EXAMINING ATTORNEY

SN 85-448,074. HOWARD, KAREN, LA JOLLA, CA. FILED 10-14-2011.

mycrushisu

THE MARK CONSISTS OF STANDARD CHARACTERS WITHOUT CLAIM TO ANY PARTICULAR FONT, STYLE, SIZE, OR COLOR.

CLASS 9—ELECTRICAL AND SCIENTIFIC APPARATUS

FOR DOWNLOADABLE COMPUTER GAME SOFTWARE FOR USE ON WIRELESS DEVICES AND COMPUTERS; DOWNLOADABLE COMPUTER SOFTWARE FOR ONLINE SOCIAL NETWORKING (U.S. CLS. 21, 23, 26, 36 AND 38).

CLASS 41—EDUCATION AND ENTERTAINMENT

FOR ENTERTAINMENT SERVICES, NAMELY, THE PROVISION OF CONTINUING TELEVISION PROGRAMS FEATURING LIVE ACTION, COMEDY, AND DRAMA; PROVIDING ONLINE COMPUTER GAMES AND NON-DOWNLOADABLE COMPUTER SOFTWARE FOR SOCIAL NETWORKING (U.S. CLS. 100, 101 AND 107).

NAPOLEON SHARMA, EXAMINING ATTORNEY

SN 85-448,106. GETFUSED, INC., BOSTON, MA. FILED 10-14-2011.

GETFUSED

THE MARK CONSISTS OF STANDARD CHARACTERS WITHOUT CLAIM TO ANY PARTICULAR FONT, STYLE, SIZE, OR COLOR.

CLASS 35—ADVERTISING AND BUSINESS

FOR CONSULTANCY SERVICES REGARDING BUSINESS STRATEGIES; MARKET RESEARCH AND BUSINESS ANALYSES; ADVERTISING AND MARKETING CONSULTANCY; ADVERTISING, MARKETING AND PROMOTION SERVICES IN THE FIELD OF EMAIL, SEARCH ENGINE OPTIMIZATION, SOCIAL MEDIA, WEB AND MOBILE (U.S. CLS. 100, 101 AND 102).
FIRST USE 5-31-1999; IN COMMERCE 5-31-1999.

CLASS 42—SCIENTIFIC AND COMPUTER SERVICES

FOR PLANNING, DESIGN AND DEVELOPMENT OF ONLINE WEBSITES FOR THIRD PARTIES; COMPUTER SOFTWARE DEVELOPMENT IN THE FIELD OF MOBILE APPLICATIONS; DESIGN AND DEVELOPMENT OF COMPUTER SOFTWARE; APPLICATION SERVICE PROVIDER, NAMELY, PROVIDING A TOOL TO ALLOW USERS TO MANAGE THEIR OWN WEBSITE; CONSULTING SERVICES IN THE DESIGN AND IMPLEMENTATION OF COMPUTER-BASED INFORMATION SYSTEMS FOR BUSINESSES (U.S. CLS. 100 AND 101).

FIRST USE 1-1-2005; IN COMMERCE 1-1-2005.
KATINA MISTER, EXAMINING ATTORNEY

SN 85-448,153. BOOM BOOM! REVOLUTION, SANTA CRUZ, CA. FILED 10-14-2011.

The Uprising of Guerilla
Goodness

THE MARK CONSISTS OF STANDARD CHARACTERS WITHOUT CLAIM TO ANY PARTICULAR FONT, STYLE, SIZE, OR COLOR.

CLASS 16—PAPER GOODS AND PRINTED MATTER

FOR TRADING CARDS (U.S. CLS. 2, 5, 22, 23, 29, 37, 38 AND 50).
FIRST USE 12-1-2006; IN COMMERCE 1-1-2007.

CLASS 42—SCIENTIFIC AND COMPUTER SERVICES

FOR PROVIDING AN INTERACTIVE WEB SITE THAT ENABLES USERS TO ENTER, ACCESS, TRACK, MONITOR AND LOCATE OTHER MEMBER USERS' ACTS OF KINDNESS (U.S. CLS. 100 AND 101).

FIRST USE 12-1-2006; IN COMMERCE 1-1-2007.
LINDA POWELL, EXAMINING ATTORNEY

SN 85-448,176. INTERMOUNTAIN BUSINESS FORMS INCORPORATED, CENTERVILLE, UT. FILED 10-14-2011.

Crusher

THE MARK CONSISTS OF STANDARD CHARACTERS WITHOUT CLAIM TO ANY PARTICULAR FONT, STYLE, SIZE, OR COLOR.

CLASS 9—ELECTRICAL AND SCIENTIFIC APPARATUS

FOR JUMPER CABLES (U.S. CLS. 21, 23, 26, 36 AND 38).

CLASS 22—CORDAGE AND FIBERS

FOR CARGO AND CARRIER EQUIPMENT FOR VEHICLES, NAMELY, TOW ROPES, TOW STRAPS, RATCHET TIE-DOWN STRAPS, QUICK RELEASE TIE DOWN STRAPS, LASHING STRAPS, AND TARP STRAPS (U.S. CLS. 1, 2, 7, 19, 22, 42 AND 50).

BERYL GARDNER, EXAMINING ATTORNEY

SN 85-448,207. CML MEDIA CORP., CULVER CITY, CA. FILED 10-14-2011.

MoPro

SN 85-448,197. OURTOWNZIP, LLC, SAN JOSE, CA. FILED 10-14-2011.

OurTownZip

THE MARK CONSISTS OF STANDARD CHARACTERS WITHOUT CLAIM TO ANY PARTICULAR FONT, STYLE, SIZE, OR COLOR.

CLASS 35—ADVERTISING AND BUSINESS

FOR ADVERTISING AND COMMERCIAL INFORMATION SERVICES, VIA THE INTERNET; ADVERTISING AND MARKETING SERVICES PROVIDED BY MEANS OF INDIRECT METHODS OF MARKETING COMMUNICATIONS, NAMELY, SOCIAL MEDIA, SEARCH ENGINE MARKETING, INQUIRY MARKETING, INTERNET MARKETING, MOBILE MARKETING, BLOGGING AND OTHER FORMS OF PASSIVE, SHARABLE OR VIRAL COMMUNICATIONS CHANNELS; ADVERTISING ON THE INTERNET FOR OTHERS; DIRECT MARKETING; DIRECT MARKETING ADVERTISING FOR OTHERS; DISSEMINATION OF ADVERTISING FOR OTHERS VIA THE INTERNET; GENERAL BUSINESS MERCHANDISING SERVICES, NAMELY, MARKETING; ON-LINE ADVERTISING AND MARKETING SERVICES; PROVIDING A SEARCHABLE ON-LINE ADVERTISING WEBSITE AND GUIDE FEATURING THE GOODS AND SERVICES OF OTHER VENDORS VIA THE INTERNET; PROVIDING AN ON-LINE COMMERCIAL INFORMATION DIRECTORY ON THE INTERNET; PROVIDING BUSINESS MARKETING INFORMATION; PROVIDING CONSUMER PRODUCT INFORMATION VIA THE INTERNET; PROVIDING MARKETING AND PROMOTION OF SPECIAL EVENTS (U.S. CLS. 100, 101 AND 102).

FIRST USE 4-28-2008; IN COMMERCE 3-22-2010.

CLASS 42—SCIENTIFIC AND COMPUTER SERVICES

FOR CREATING AND MAINTAINING INTERNET SITES FOR OTHERS; DESIGN, CREATION, HOSTING AND MAINTENANCE OF INTERNET SITES FOR THIRD PARTIES; DESIGNING AND DEVELOPING WEBPAGES ON THE INTERNET; DESIGNING INTERNET SITES FOR OTHERS; HOSTING WEBSITES ON THE INTERNET; WEB PUBLISHING, NAMELY, CREATING A WEBSITE AND UPLOADING IT ONTO AN INTERNET SERVER (U.S. CLS. 100 AND 101).

FIRST USE 4-28-2008; IN COMMERCE 3-22-2010.
ELIZABETH HUGHITT, EXAMINING ATTORNEY

THE MARK CONSISTS OF STANDARD CHARACTERS WITHOUT CLAIM TO ANY PARTICULAR FONT, STYLE, SIZE, OR COLOR.

CLASS 35—ADVERTISING AND BUSINESS

FOR PROVIDING ADVERTISING, MARKETING AND PROMOTIONAL SERVICES, NAMELY THE CREATION OF VIDEO, PRINT, GRAPHIC DESIGN AND DIGITAL PHOTOGRAPHY FOR INTERNET AND TELEVISION BASED MARKETING AND PROMOTIONAL SERVICES FOR THIRD PARTIES (U.S. CLS. 100, 101 AND 102).

CLASS 42—SCIENTIFIC AND COMPUTER SERVICES

FOR CREATION, DESIGN, DEVELOPMENT AND MAINTENANCE OF WEB SITES FOR THIRD PARTIES (U.S. CLS. 100 AND 101).

NAAKWAMA ANKRAH, EXAMINING ATTORNEY

SN 85-448,244. ROTO SPORTS, INC., MADISON, WI. FILED 10-14-2011.

ROTOWIRE

THE MARK CONSISTS OF STANDARD CHARACTERS WITHOUT CLAIM TO ANY PARTICULAR FONT, STYLE, SIZE, OR COLOR.

CLASS 16—PAPER GOODS AND PRINTED MATTER

FOR MAGAZINES IN THE FIELD OF SPORTS (U.S. CLS. 2, 5, 22, 23, 29, 37, 38 AND 50).

FIRST USE 7-0-2001; IN COMMERCE 7-0-2001.

CLASS 41—EDUCATION AND ENTERTAINMENT

FOR ENTERTAINMENT SERVICES IN THE NATURE OF FANTASY SPORTS LEAGUES; PROVIDING NEWS AND INFORMATION IN THE FIELD OF SPORTS (U.S. CLS. 100, 101 AND 107).

FIRST USE 4-1-2001; IN COMMERCE 4-1-2001.
JENNIFER WILLISTON, EXAMINING ATTORNEY

SN 85-448,276. CPRSERVICES, CORALVILLE, IA. FILED 10-15-2011.

Rx:Forgiveness

THE MARK CONSISTS OF STANDARD CHARACTERS WITHOUT CLAIM TO ANY PARTICULAR FONT, STYLE, SIZE, OR COLOR.

CLASS 9—ELECTRICAL AND SCIENTIFIC APPARATUS

FOR AUDIO BOOKS IN THE FIELD OF MENTAL HEALTH; COMPUTER SOFTWARE FOR THE COLLECTION, EDITING, ORGANIZING, MODIFYING, BOOK MARKING, TRANSMISSION, STORAGE AND SHARING OF DATA AND INFORMATION; ELECTRONIC BOOK READER (U.S. CLS. 21, 23, 26, 36 AND 38).

CLASS 16—PAPER GOODS AND PRINTED MATTER

FOR A SERIES OF BOOKS, WRITTEN ARTICLES, HANDOUTS AND WORKSHEETS IN THE FIELD OF MENTAL HEALTH, MEDICINE, HEALING (U.S. CLS. 2, 5, 22, 23, 29, 37, 38 AND 50).

CLASS 35—ADVERTISING AND BUSINESS

FOR ADVERTISING SERVICES, NAMELY, CREATING CORPORATE LOGOS FOR OTHERS; PREPARING SPEECHES AND ORAL PRESENTATIONS FOR OTHERS FOR USE IN ADVERTISING (U.S. CLS. 100, 101 AND 102).

CLASS 40—MATERIAL TREATMENT

FOR CUSTOMIZED IMPRINTING OF COMPANY NAMES AND LOGOS ON THE GOODS OF OTHERS, NAMELY, ON PROMOTIONAL MERCHANDISE, APPAREL AND CORPORATE GIFTS (U.S. CLS. 100, 103 AND 106).

CLASS 42—SCIENTIFIC AND COMPUTER SERVICES

FOR GRAPHIC DESIGN SERVICES FOR CLOTHES (U.S. CLS. 100 AND 101).
ELI HELLMAN, EXAMINING ATTORNEY

SN 85-448,282. PERICHE, FERNANDO, PARIS, FRANCE, AND COTE-COLISSON, JULIEN, BAGNEUX, FRANCE, FILED 10-15-2011.

CHARBON ROUGE

THE MARK CONSISTS OF STANDARD CHARACTERS WITHOUT CLAIM TO ANY PARTICULAR FONT, STYLE, SIZE, OR COLOR.

THE ENGLISH TRANSLATION OF "CHARBON ROUGE" IN THE MARK IS "RED COAL".

CLASS 29—MEATS AND PROCESSED FOODS

FOR MEAT, FISH, POULTRY AND GAME; MEAT EXTRACTS; PRESERVED FROZEN, DRIED AND COOKED FRUITS AND VEGETABLES; JELLIES, JAMS, COMPOTES (U.S. CL. 46).

CLASS 35—ADVERTISING AND BUSINESS

FOR RESTAURANT FRANCHISING, NAMELY, OFFERING BUSINESS MANAGEMENT ASSISTANCE IN THE ESTABLISHMENT AND/OR OPERATION OF RESTAURANTS; ONLINE RETAIL STORE SERVICES FEATURING FOOD PRODUCTS (U.S. CLS. 100, 101 AND 102).

CLASS 43—HOTEL AND RESTAURANT SERVICES

FOR RESTAURANT SERVICES (U.S. CLS. 100 AND 101).
ELI HELLMAN, EXAMINING ATTORNEY

SN 85-448,364. DREW JOANIDES, MIAMI, FL. FILED 10-15-2011.

My hood's in the woods

THE MARK CONSISTS OF STANDARD CHARACTERS WITHOUT CLAIM TO ANY PARTICULAR FONT, STYLE, SIZE, OR COLOR.

CLASS 21—HOUSEWARES AND GLASS

FOR CUPS AND MUGS (U.S. CLS. 2, 13, 23, 29, 30, 33, 40 AND 50).

CLASS 25—CLOTHING

FOR ATHLETIC APPAREL, NAMELY, SHIRTS, PANTS, JACKETS, FOOTWEAR, HATS AND CAPS, ATHLETIC UNIFORMS; CAMOUFLAGE SHIRTS (U.S. CLS. 22 AND 39).
DAVID HOFFMAN, EXAMINING ATTORNEY

SN 85-448,456. LEIZERMAN, ERWIN JOEL, TOLEDO, OH. FILED 10-16-2011.

STÜCK

THE MARK CONSISTS OF STANDARD CHARACTERS WITHOUT CLAIM TO ANY PARTICULAR FONT, STYLE, SIZE, OR COLOR.

CLASS 18—LEATHER GOODS

FOR CARRY-ALL BAGS; DUFFEL BAGS; DUFFEL BAGS FOR TRAVEL (U.S. CLS. 1, 2, 3, 22 AND 41).

CLASS 25—CLOTHING

FOR ATHLETIC APPAREL, NAMELY, SHIRTS, PANTS, JACKETS, FOOTWEAR, HATS AND CAPS, ATHLETIC UNIFORMS; ATHLETIC FOOTWEAR; ATHLETIC SHOES; BASEBALL CAPS AND HATS; HATS; T-SHIRTS (U.S. CLS. 22 AND 39).

WILLIAM VERHOSEK, EXAMINING ATTORNEY

SN 85-448,476. KRISTEN L OLSEN, AURORA, OH. FILED 10-16-2011.

ARTFUL EXPEDITIONS

THE MARK CONSISTS OF STANDARD CHARACTERS WITHOUT CLAIM TO ANY PARTICULAR FONT, STYLE, SIZE, OR COLOR.

CLASS 39—TRANSPORTATION AND STORAGE

FOR ARRANGING TRAVEL TOURS (U.S. CLS. 100 AND 105).

FIRST USE 10-16-2011; IN COMMERCE 10-16-2011.

CLASS 44—MEDICAL, BEAUTY AND AGRICULTURAL SERVICES

FOR ART THERAPY (U.S. CLS. 100 AND 101).
FIRST USE 10-16-2011; IN COMMERCE 10-16-2011.
JILL C. ALT, EXAMINING ATTORNEY

SN 85-448,493. FERWERDA, KATHERINE, DBA KATHERINE FERWERDA, LOS ANGELES, CA. FILED 10-17-2011.

MY PLANET ROX

THE MARK CONSISTS OF STANDARD CHARACTERS WITHOUT CLAIM TO ANY PARTICULAR FONT, STYLE, SIZE, OR COLOR.

CLASS 9—ELECTRICAL AND SCIENTIFIC APPARATUS

FOR CHILDREN'S EDUCATIONAL MUSIC CDS AND DVDS; MOTION PICTURE FILMS AND FILMS FOR TELEVISION FEATURING CHILDREN'S ENTERTAINMENT (U.S. CLS. 21, 23, 26, 36 AND 38).

CLASS 16—PAPER GOODS AND PRINTED MATTER

FOR CHILDREN'S ACTIVITY BOOKS; CHILDREN'S BOOKS; CHILDREN'S INTERACTIVE EDUCATIONAL BOOKS; COMIC BOOKS; ROLE PLAYING GAME EQUIPMENT IN THE NATURE OF GAME BOOK MANUALS; SERIES OF COMPUTER GAME HINT BOOKS (U.S. CLS. 2, 5, 22, 23, 29, 37, 38 AND 50).

CLASS 18—LEATHER GOODS

FOR BACKPACKS, BOOK BAGS, SPORTS BAGS, BUM BAGS, WALLETS AND HANDBAGS (U.S. CLS. 1, 2, 3, 22 AND 41).

CLASS 25—CLOTHING

FOR HOODED SWEATSHIRTS FOR CHILDREN; SHIRTS FOR INFANTS, BABIES, TODDLERS AND CHILDREN; SWEATSHIRTS FOR CHILDREN; T-SHIRTS FOR CHILDREN (U.S. CLS. 22 AND 39).

CLASS 28—TOYS AND SPORTING GOODS

FOR CHILDREN'S MULTIPLE ACTIVITY TOYS SOLD AS A UNIT WITH PRINTED BOOKS; ELECTRONIC EDUCATIONAL GAME MACHINES FOR CHILDREN; ELECTRONIC GAMES FOR THE TEACHING OF CHILDREN; FITNESS EQUIPMENT, NAMELY, STRAPS USED FOR YOGA AND OTHER FITNESS ACTIVITIES AND FOR CARRYING A YOGA MAT; OUTDOOR ACTIVITY GAME EQUIPMENT IN THE NATURE OF SPORTS BALLS, SKATEBOARDS, SURF BOARDS; PUZZLE GAMES (U.S. CLS. 22, 23, 38 AND 50).

CLASS 41—EDUCATION AND ENTERTAINMENT

FOR ENTERTAINMENT SERVICES IN THE NATURE OF ON-GOING TELEVISION PROGRAMS IN THE FIELD OF CHILDREN'S ENTERTAINMENT; ENTERTAINMENT SERVICES, NAMELY, AN ON-LINE ACTIVITY WHERE YOU CREATE YOUR OWN MUSIC VIDEOS; ENTERTAINMENT SERVICES, NAMELY, PROVIDING A WEB SITE FEATURING NON-DOWNLOADABLE MUSICAL PERFORMANCES, MUSICAL VIDEOS, RELATED FILM CLIPS, PHOTOGRAPHS, AND OTHER MULTIMEDIA MATERIALS FEATURING EDUCATIONAL ENTERTAINMENT FOR CHILDREN AGES 6-11, PAIRING SCIENCE CONCEPTS WITH CURRENT ENVIRONMENTAL TRENDS EXPRESSED THROUGH ROCK MUSIC, ANIMATION, LIVE ACTION PROGRAMMING.; PROVIDING A WEBSITE FEATURING INFORMATION IN THE FIELDS OF EDUCATION AND ENTERTAINMENT FOR CHILDREN (U.S. CLS. 100, 101 AND 107).

FONG HSU, EXAMINING ATTORNEY

SN 85-448,512. GETFUSED, INC., BOSTON, MA. FILED 10-17-2011.

THE COLOR(S) BLACK AND YELLOW IS/ARE CLAIMED AS A FEATURE OF THE MARK.

THE MARK CONSISTS OF THE WORD GETFUSED WHEREIN THE WORD "GET" IS IN BLACK AND THE WORD "FUSED" IS IN YELLOW.

CLASS 35—ADVERTISING AND BUSINESS

FOR CONSULTANCY SERVICES REGARDING BUSINESS STRATEGIES; MARKET RESEARCH AND BUSINESS ANALYSES; ADVERTISING AND MARKETING CONSULTANCY; ADVERTISING, MARKETING AND PROMOTION SERVICES IN THE FIELD OF EMAIL, SEARCH ENGINE OPTIMIZATION, SOCIAL MEDIA, WEB AND MOBILE (U.S. CLS. 100, 101 AND 102).

FIRST USE 5-31-1999; IN COMMERCE 5-31-1999.

CLASS 42—SCIENTIFIC AND COMPUTER SERVICES

FOR PLANNING, DESIGN AND DEVELOPMENT OF ONLINE WEBSITES FOR THIRD PARTIES; COMPUTER SOFTWARE DEVELOPMENT IN THE FIELD OF MOBILE APPLICATIONS; DESIGN AND DEVELOPMENT OF COMPUTER SOFTWARE; APPLICATION SERVICE PROVIDER, NAMELY, PROVIDING A TOOL TO ALLOW USERS TO MANAGE THEIR OWN WEBSITE; CONSULTING SERVICES IN THE DESIGN AND IMPLEMENTATION OF COMPUTER BASED INFORMATION SYSTEMS FOR BUSINESSES (U.S. CLS. 100 AND 101).

FIRST USE 1-1-2005; IN COMMERCE 1-1-2005.
KATINA MISTER, EXAMINING ATTORNEY

SN 85-448,580. ART IS MY WEAPON LLC, NEW YORK, NY. FILED 10-17-2011.



THE COLOR(S) RED AND WHITE IS/ARE CLAIMED AS A FEATURE OF THE MARK.
THE MARK CONSISTS OF RED RECTANGLE WITH "ART IS MY WEAPON" IN WHITE STYLIZED FONT.

CLASS 9—ELECTRICAL AND SCIENTIFIC APPARATUS

FOR DOWNLOADABLE SOFTWARE IN THE NATURE OF A MOBILE APPLICATION FOR STREAMING VIDEO AND AUDIO CONTENT (U.S. CLS. 21, 23, 26, 36 AND 38).

CLASS 41—EDUCATION AND ENTERTAINMENT

FOR DIGITAL VIDEO, AUDIO, AND MULTIMEDIA PUBLISHING SERVICES; ENTERTAINMENT SERVICES, NAMELY, PROVIDING A WEB SITE FEATURING NON-DOWNLOADABLE MUSICAL PERFORMANCES, MUSICAL VIDEOS, RELATED FILM CLIPS, PHOTOGRAPHS, AND OTHER MULTIMEDIA MATERIALS FEATURING ART; FILM AND VIDEO PRODUCTION; PROVIDING A WEBSITE FOR ENTERTAINMENT PURPOSES WHERE USERS CAN VIEW AND POST VIDEO, PHOTOS AND AUDIO CONTENT FEATURING ART (U.S. CLS. 100, 101 AND 107).

PAUL MORENO, EXAMINING ATTORNEY

SN 85-448,597. PHIL WALDREP EVANGELISTIC ASSOCIATION, TRINITY, AL. FILED 10-17-2011.

WOMEN OF JOY

THE MARK CONSISTS OF STANDARD CHARACTERS WITHOUT CLAIM TO ANY PARTICULAR FONT, STYLE, SIZE, OR COLOR.

CLASS 9—ELECTRICAL AND SCIENTIFIC APPARATUS

FOR DOWNLOADABLE ELECTRONIC NEWSLETTERS DELIVERED BY EMAIL ON THE SUBJECT OF WOMEN AND CHRISTIANITY (U.S. CLS. 21, 23, 26, 36 AND 38).

CLASS 16—PAPER GOODS AND PRINTED MATTER

FOR BOOKS, BOOKLETS, MAGAZINES, NEWSLETTERS, AND PAMPHLETS, ALL ON THE SUBJECT OF WOMEN AND CHRISTIANITY (U.S. CLS. 2, 5, 22, 23, 29, 37, 38 AND 50).

CLASS 41—EDUCATION AND ENTERTAINMENT

FOR EDUCATIONAL SERVICES, NAMELY, CONDUCTING CHRISTIAN CONFERENCES, RETREATS, SEMINARS, LECTURES, CLASSES, AND WORKSHOPS, ALL ON THE SUBJECT OF WOMEN AND CHRISTIANITY (U.S. CLS. 100, 101 AND 107).

FIRST USE 0-0-2004; IN COMMERCE 0-0-2004.
THOMAS MANOR, EXAMINING ATTORNEY

SN 85-448,685. DARRELL MCDONALD, IRVING, TX. FILED 10-17-2011.

SILENT PLAYER

THE MARK CONSISTS OF STANDARD CHARACTERS WITHOUT CLAIM TO ANY PARTICULAR FONT, STYLE, SIZE, OR COLOR.

CLASS 25—CLOTHING

FOR CLOTHING, NAMELY, SHIRTS, HATS, SWEATSHIRTS, T-SHIRTS, TANK TOPS, SHORTS AND SWEATPANTS (U.S. CLS. 22 AND 39).

FIRST USE 8-19-1999; IN COMMERCE 8-19-1999.

CLASS 28—TOYS AND SPORTING GOODS

FOR SPORTS TRAINING EQUIPMENT, NAMELY, A HUMAN SIZED AND SHAPED MANNEQUIN USED FOR SIMULATING OPPOSING TEAM MEMBERS (U.S. CLS. 22, 23, 38 AND 50).

FIRST USE 2-3-1999; IN COMMERCE 2-3-1999.
LIEF MARTIN, EXAMINING ATTORNEY

SN 85-448,692. HEALTHWELL HOLDINGS CORPORATION, COSTA MESA, CA. FILED 10-17-2011.

Poosh

THE MARK CONSISTS OF STANDARD CHARACTERS WITHOUT CLAIM TO ANY PARTICULAR FONT, STYLE, SIZE, OR COLOR.

CLASS 35—ADVERTISING AND BUSINESS

FOR PROMOTING AND MARKETING THE GOODS AND SERVICES OF OTHERS BY DISTRIBUTING ADVERTISING MATERIAL, COUPONS AND DISCOUNT OFFERS VIA TEXT MESSAGES (U.S. CLS. 100, 101 AND 102).

FIRST USE 9-13-2011; IN COMMERCE 9-13-2011.

CLASS 45—PERSONAL AND LEGAL SERVICES

FOR PROVIDING A MOTIVATIONAL WEBSITE THE PRIMARY MISSION OF WHICH IS TO INCREASE PERSONAL HAPPINESS IN TERMS OF PERSONAL RELATIONSHIPS, PERSONAL GROWTH AND MOTIVATION, AND SELF-FULFILLMENT (U.S. CLS. 100 AND 101).

FIRST USE 9-13-2011; IN COMMERCE 9-13-2011.
MICHAEL GAFFAR, EXAMINING ATTORNEY

SN 85-448,703. ITALK INTERNATIONAL INC, CHICO, CA. FILED 10-17-2011.

TIMELESS WISDOM 4 THE AGE
OF TECHNOLOGY

THE MARK CONSISTS OF STANDARD CHARACTERS WITHOUT CLAIM TO ANY PARTICULAR FONT, STYLE, SIZE, OR COLOR.

CLASS 9—ELECTRICAL AND SCIENTIFIC APPARATUS

FOR (BASED ON USE IN COMMERCE) AUDIO BOOKS IN THE FIELD OF SELF-HELP; AUDIO RECORDINGS FEATURING SELF-IMPROVEMENT; DOWNLOADABLE MP3 FILES, MP3 RECORDINGS, ON-LINE DISCUSSION BOARDS, WEBCASTS, WEBINARS AND PODCASTS FEATURING MUSIC, AUDIO BOOKS IN THE FIELD OF SELF-HELP, AND NEWS BROADCASTS; ELECTRONIC PUBLICATIONS, NAMELY, BOOK FEATURING SELF-HELP RECORDED ON COMPUTER MEDIA(BASED ON INTENT TO USE) AUDIO AND VIDEO RECORDINGS FEATURING SELF-IMPROVEMENT; DOWNLOADABLE ELECTRONIC NEWSLETTERS DELIVERED BY E-MAIL IN THE FIELD OF SELF-IMPROVEMENT; DOWNLOADABLE ELECTRONIC NEWSLETTERS IN THE FIELD OF SELF-HELP (U.S. CLS. 21, 23, 26, 36 AND 38).

FIRST USE 4-12-2011; IN COMMERCE 6-12-2011.

CLASS 16—PAPER GOODS AND PRINTED MATTER

FOR (BASED ON USE IN COMMERCE) A SERIES OF BOOKS AND WRITTEN ARTICLES IN THE FIELD OF SELF-HELP; A SERIES OF BOOKS, WRITTEN ARTICLES, HANDOUTS AND WORKSHEETS IN THE FIELD OF SELF-HELP; BOOKS IN THE FIELD OF SELF-HELP(BASED ON INTENT TO USE) COOK BOOKS; RECIPE BOOKS; WEIGHT LOSS PROGRAM KITS CONSISTING PRIMARILY OF PRINTED BOOKS ON WEIGHT LOSS AND DIETING, AND ALSO INCLUDING VITAMIN SUPPLEMENTS AND HORMONES (U.S. CLS. 2, 5, 22, 23, 29, 37, 38 AND 50).

FIRST USE 4-12-2011; IN COMMERCE 6-12-2011.
KATHLEEN LORENZO, EXAMINING ATTORNEY

SN 85-448,712. BLANCO, 75038 OBERDERDINGEN, FED REP GERMANY, FILED 10-17-2011.

QUATRUS

THE MARK CONSISTS OF STANDARD CHARACTERS WITHOUT CLAIM TO ANY PARTICULAR FONT, STYLE, SIZE, OR COLOR.

CLASS 11—ENVIRONMENTAL CONTROL APPARATUS

FOR SINKS; SINKS HAVING A DRAINING AREA; SINKS WITHOUT A DRAINING AREA; SINK BASINS; UNDERMOUNT SINK BOWLS; PARTS OF AND FITTINGS FOR THE AFORESAID GOODS (U.S. CLS. 13, 21, 23, 31 AND 34).

CLASS 21—HOUSEWARES AND GLASS

FOR PREPARATION BOWLS; WASTE BASKETS FOR KITCHEN SINKS; CHOPPING BOARDS FOR KITCHEN USE; SINK ACCESSORIES, NAMELY, CUTTING BOARDS, COLANDERS AND DISH DRYING RACKS; PARTS OF AND FITTINGS FOR THE AFORESAID GOODS (U.S. CLS. 2, 13, 23, 29, 30, 33, 40 AND 50).

WILLIAM ROSSMAN, EXAMINING ATTORNEY

SN 85-448,718. ESOMAR B.V., AMSTERDAM, NETHERLANDS, FILED 10-17-2011.

FRINGE FACTORY

THE MARK CONSISTS OF STANDARD CHARACTERS WITHOUT CLAIM TO ANY PARTICULAR FONT, STYLE, SIZE, OR COLOR.

CLASS 35—ADVERTISING AND BUSINESS

FOR ADVERTISING, MARKETING AND PROMOTION SERVICES; ARRANGING AND CONDUCTING MARKETING PROMOTIONAL EVENTS FOR OTHERS; MARKET ANALYSIS AND RESEARCH SERVICES; MARKET RESEARCH CONSULTATION; PROVIDING BUSINESS INFORMATION, ALSO VIA INTERNET, THE CABLE NETWORK OR OTHER FORMS OF DATA TRANSFER; PROVIDING INFORMATION AND ANALYSIS IN THE FIELDS OF ECONOMICS AND BUSINESS; PROVISION OF ADVERTISING SPACE BY ELECTRONIC MEANS AND GLOBAL INFORMATION NETWORKS; PUBLIC RELATIONS; PUBLICITY CONSULTATION (U.S. CLS. 100, 101 AND 102).

CLASS 41—EDUCATION AND ENTERTAINMENT

FOR EDUCATION SERVICES, NAMELY, PROVIDING CONGRESSES, DISCUSSION GROUPS, CONFERENCES, SEMINARS, AND TRAINING COURSES IN THE FIELD OF PUBLICITY, PUBLIC RELATIONS, MARKETING, AND MARKET RESEARCH; PUBLICATION OF BOOKS, NEWSPAPERS, JOURNALS, MAGAZINES, PERIODICALS, LEAFLETS, SOFTWARE, FRAGMENTS AND EXTRACTS OF BOOKS, JOURNALS, AND OTHER PUBLICATIONS (U.S. CLS. 100, 101 AND 107).

WILLIAM ROSSMAN, EXAMINING ATTORNEY

SN 85-448,739. HEALTHWELL HOLDINGS CORPORATION, COSTA MESA, CA. FILED 10-17-2011.

SN 85-448,816. SODEXO, ISSY LES MOULINEAUX, FRANCE, FILED 10-17-2011.



THE MARK CONSISTS OF THE WORD "POOSH" IN SANS-SERIF STYLE FONT TYPE. THE "P" IS STYLIZED. THE LOOP OF THE "P" IS A SQUARE OR BOX SHAPE AND THE ENDS OF THE "P" ARE SHARP OR COME TO A POINT.

CLASS 35—ADVERTISING AND BUSINESS

FOR PROMOTING AND MARKETING THE GOODS AND SERVICES OF OTHERS BY DISTRIBUTING ADVERTISING MATERIAL, COUPONS AND DISCOUNT OFFERS VIA TEXT MESSAGES (U.S. CLS. 100, 101 AND 102).

FIRST USE 9-13-2011; IN COMMERCE 9-13-2011.

CLASS 45—PERSONAL AND LEGAL SERVICES

FOR PROVIDING A MOTIVATIONAL WEBSITE THE PRIMARY MISSION OF WHICH IS TO INCREASE PERSONAL HAPPINESS IN TERMS OF PERSONAL RELATIONSHIPS, PERSONAL GROWTH AND MOTIVATION, AND SELF-FULFILLMENT (U.S. CLS. 100 AND 101).

FIRST USE 9-13-2011; IN COMMERCE 9-13-2011. MICHAEL GAAFAR, EXAMINING ATTORNEY

SN 85-448,811. HEALTHATION, INC., SAN DIEGO, CA. FILED 10-17-2011.



THE MARK CONSISTS OF STANDARD CHARACTERS WITHOUT CLAIM TO ANY PARTICULAR FONT, STYLE, SIZE, OR COLOR.

CLASS 9—ELECTRICAL AND SCIENTIFIC APPARATUS

FOR COMPUTER SOFTWARE FOR ADMINISTRATION, ENROLLMENT, BILLING AND CLAIMS PROCESSING AND MANAGEMENT FOR HEALTHCARE BENEFITS AND HEALTH INSURANCE (U.S. CLS. 21, 23, 26, 36 AND 38).

FIRST USE 4-1-2005; IN COMMERCE 4-1-2005.

CLASS 42—SCIENTIFIC AND COMPUTER SERVICES

FOR APPLICATION SERVICE PROVIDER, NAMELY, HOSTING, MANAGING, ANALYZING, AND MAINTAINING APPLICATIONS AND SOFTWARE IN THE FIELDS OF HEALTHCARE BENEFITS AND HEALTH INSURANCE, AND FOR ADMINISTRATION, ENROLLMENT, BILLING AND CLAIMS PROCESSING AND MANAGEMENT FOR HEALTHCARE BENEFITS AND HEALTH INSURANCE (U.S. CLS. 100 AND 101).

FIRST USE 5-0-2004; IN COMMERCE 5-0-2004. CARYN GLASSER, EXAMINING ATTORNEY



THE MARK CONSISTS OF THE WORDS ULTIMATE PASS IN STYLIZED LETTERS.

CLASS 35—ADVERTISING AND BUSINESS

FOR PROVIDING INCENTIVE AWARD AND RECOGNITION PROGRAMS FOR CUSTOMERS, BUSINESS PARTNERS AND EMPLOYEES THROUGH THE DISTRIBUTION OF PREPAID STORED VALUE CARDS FOR HONORING VALUED EMPLOYEES AND CUSTOMERS, REWARDING GOOD PERFORMANCE AND PROMOTING LOYALTY (U.S. CLS. 100, 101 AND 102).

CLASS 36—INSURANCE AND FINANCIAL

FOR ISSUING STORED VALUE CARDS FOR USE IN INCENTIVE AWARD AND RECOGNITION PROGRAMS FOR EMPLOYEES, BUSINESS PARTNERS AND CUSTOMERS (U.S. CLS. 100, 101 AND 102).

CARYN GLASSER, EXAMINING ATTORNEY

SN 85-448,832. REAL, JOSELITO, G., WOODLAND, CA. FILED 10-17-2011.



THE MARK CONSISTS OF STANDARD CHARACTERS WITHOUT CLAIM TO ANY PARTICULAR FONT, STYLE, SIZE, OR COLOR.

CLASS 1—CHEMICALS

FOR COMPLEX FERTILIZER; COMPLEX FERTILIZERS; FERTILIZERS; FERTILIZERS FOR AGRICULTURAL USE; FERTILIZERS FOR DOMESTIC USE; MIXED FERTILIZERS; NATURAL FERTILIZERS; NON-CHEMICAL BIO-FERTILIZERS; NUTRITIVE ADDITIVE TO ENHANCE THE BIOLOGICAL ACTIVITY OF WATER, SOIL, SEEDS AND PLANTS FOR PURPOSES OF FERTILIZATION AND BIOREMEDIATION OF POLLUTANTS; ORGANIC SOIL ENHANCEMENT POWDERS AND PREPARATIONS (U.S. CLS. 1, 5, 6, 10, 26 AND 46).

CLASS 5—PHARMACEUTICALS

FOR AGRICULTURAL PESTICIDES; BIOCIDES, GERMICIDES, BACTERICIDES, VIRUCIDES, FUNGICIDES, INSECTICIDES, PESTICIDES AND HERBICIDES; DOMESTIC PESTICIDES; HERBICIDES, INSECTICIDES, PESTICIDES AND FUNGICIDES FOR HOME, GARDEN AND LAWN USE AND FOR PROFESSIONAL USE; NEMATOCIDES; NEMATODE PESTICIDE; PESTICIDES FOR AGRICULTURAL USE (U.S. CLS. 6, 18, 44, 46, 51 AND 52).

CHRISTINE MARTIN, EXAMINING ATTORNEY

SN 85-448,921. TCG HOLDINGS, LP, FORT WORTH, TX.
FILED 10-17-2011.

SN 85-448,957. FUJIMORI KOGYO, CO., LTD., SHINJUKU-
KU, TOKYO, JAPAN, FILED 10-17-2011.

THE BRENNITY

THE MARK CONSISTS OF STANDARD CHARACTERS WITHOUT CLAIM TO ANY PARTICULAR FONT, STYLE, SIZE, OR COLOR.

CLASS 43—HOTEL AND RESTAURANT SERVICES

FOR PROVIDING ASSISTED LIVING FACILITIES (U.S. CLS. 100 AND 101).

CLASS 44—MEDICAL, BEAUTY AND AGRICULTURAL SERVICES

FOR NURSING HOMES; HEALTH CARE SERVICES; PROVIDING LONG-TERM CARE FACILITIES (U.S. CLS. 100 AND 101).

KATHY DE JONGE, EXAMINING ATTORNEY

ZACROS

THE MARK CONSISTS OF STANDARD CHARACTERS WITHOUT CLAIM TO ANY PARTICULAR FONT, STYLE, SIZE, OR COLOR.

CLASS 17—RUBBER GOODS

FOR SEMI-PROCESSED PLASTICS (U.S. CLS. 1, 5, 12, 13, 35 AND 50).

FIRST USE 11-12-1997; IN COMMERCE 11-12-1997.

CLASS 20—FURNITURE AND ARTICLES NOT OTHERWISE CLASSIFIED

FOR PACKAGING CONTAINERS OF PLASTIC (U.S. CLS. 2, 13, 22, 25, 32 AND 50).

FIRST USE 10-23-2011; IN COMMERCE 10-23-2011.

DAWN FELDMAN, EXAMINING ATTORNEY

SN 85-448,942. TRUE NORTH EQUIPMENT COMPANY,
GRAFTON, ND. FILED 10-17-2011.

SN 85-448,998. COUNTRY LIFE OUTFITTERS INC, PANAMA CITY, FL. FILED 10-17-2011.



THE MARK CONSISTS OF PARTIAL OUTLINE OF SIDE VIEW OF FARM TRACTOR, SHOWING PART OF TOP SECTION OF TRACTOR AND PART OF TWO TIRES.

CLASS 35—ADVERTISING AND BUSINESS

FOR RETAIL STORE SERVICES FEATURING AGRICULTURAL, COMMERCIAL TURF, LAWN AND GROUNDS, HOMEOWNER AND LARGE PROPERTY OWNER GROUNDS-KEEPING AND LAWN-MAINTENANCE EQUIPMENT AND PRODUCTS (U.S. CLS. 100, 101 AND 102).

FIRST USE 10-1-2011; IN COMMERCE 10-1-2011.

CLASS 37—CONSTRUCTION AND REPAIR

FOR MACHINERY MAINTENANCE AND REPAIR (U.S. CLS. 100, 103 AND 106).

FIRST USE 10-1-2011; IN COMMERCE 10-1-2011.

TARAH HARDY, EXAMINING ATTORNEY

Hunter Chick

THE MARK CONSISTS OF STANDARD CHARACTERS WITHOUT CLAIM TO ANY PARTICULAR FONT, STYLE, SIZE, OR COLOR.

CLASS 16—PAPER GOODS AND PRINTED MATTER

FOR DECALS; DECORATIVE DECALS FOR VEHICLE WINDOWS (U.S. CLS. 2, 5, 22, 23, 29, 37, 38 AND 50).

FIRST USE 11-2-2009; IN COMMERCE 11-2-2009.

CLASS 25—CLOTHING

FOR FISHING SHIRTS; HUNTING SHIRTS; LONG-SLEEVED SHIRTS; SPORTS SHIRTS; SWEAT SHIRTS; T-SHIRTS (U.S. CLS. 22 AND 39).

FIRST USE 11-2-2009; IN COMMERCE 11-2-2009.

ANDREA HACK, EXAMINING ATTORNEY

SN 85-449,020. SIGMA-ALDRICH INC., ST. LOUIS, MO.
FILED 10-17-2011.

SN 85-449,085. SOCIÉTÉ DES PRODUITS NESTLÉ S.A., 1800
VEVEY, SWITZERLAND, FILED 10-17-2011.



THE MARK CONSISTS OF A FILLED CIRCLE CON-
TAINED WITHIN A CURVED OR CRESCENT-SHAPED
BAND.

CLASS 35—ADVERTISING AND BUSINESS

FOR PROCUREMENT SERVICES, NAMELY, SELEC-
TION AND PURCHASE OF CHEMICAL REAGENTS
FOR OTHERS, ON-LINE ORDERING SERVICES FEAT-
URING CHEMICAL REAGENTS, AND CONSULTA-
TION SERVICES RELATED THERETO (U.S. CLS. 100,
101 AND 102).

FIRST USE 1-13-2000; IN COMMERCE 1-26-2000.

**CLASS 42—SCIENTIFIC AND COMPUTER
SERVICES**

FOR ON-LINE CONSULTATION IN THE FIELD OF
CHEMICAL REAGENTS VIA AN ELECTRONIC COM-
PUTER NETWORK (U.S. CLS. 100 AND 101).

FIRST USE 1-13-2000; IN COMMERCE 1-26-2000.
FRANK LATTUCA, EXAMINING ATTORNEY

SN 85-449,036. HOTEL KIOSKS, INC., SIMI VALLEY, CA.
FILED 10-17-2011.

BEYONDTV

THE MARK CONSISTS OF STANDARD CHARACTERS
WITHOUT CLAIM TO ANY PARTICULAR FONT, STYLE,
SIZE, OR COLOR.

**CLASS 9—ELECTRICAL AND SCIENTIFIC
APPARATUS**

FOR COMPUTER HARDWARE AND COMPUTER
SOFTWARE PROGRAMS FOR THE INTEGRATION OF
TEXT, AUDIO, GRAPHICS, STILL IMAGES AND MOV-
ING PICTURES INTO AN INTERACTIVE DELIVERY
FOR MULTIMEDIA APPLICATIONS (U.S. CLS. 21, 23,
26, 36 AND 38).

FIRST USE 10-1-2011; IN COMMERCE 10-8-2011.

CLASS 38—COMMUNICATION

FOR INTERNET PROTOCOL TELEVISION (IPTV)
TRANSMISSION SERVICES (U.S. CLS. 100, 101 AND 104).
FIRST USE 10-1-2011; IN COMMERCE 10-8-2011.
GRETTA YAO, EXAMINING ATTORNEY

MY 2ND CEREALS

THE MARK CONSISTS OF STANDARD CHARACTERS
WITHOUT CLAIM TO ANY PARTICULAR FONT, STYLE,
SIZE, OR COLOR.

NO CLAIM IS MADE TO THE EXCLUSIVE RIGHT TO
USE "CEREALS", APART FROM THE MARK AS SHOWN.

CLASS 5—PHARMACEUTICALS

FOR BABY FOODS (U.S. CLS. 6, 18, 44, 46, 51 AND 52).

CLASS 30—STAPLE FOODS

FOR BREAKFAST CEREALS; READY-TO-EAT CER-
EALS (U.S. CL. 46).

JESSICA FATHY, EXAMINING ATTORNEY

SN 85-449,118. TWAALFHOVEN, ROBERT, SAN JOSE, CA.
FILED 10-17-2011.

APP TREASURE HUNTER

THE MARK CONSISTS OF STANDARD CHARACTERS
WITHOUT CLAIM TO ANY PARTICULAR FONT, STYLE,
SIZE, OR COLOR.

NO CLAIM IS MADE TO THE EXCLUSIVE RIGHT TO
USE "APP", APART FROM THE MARK AS SHOWN.

CLASS 35—ADVERTISING AND BUSINESS

FOR PROVIDING A WEB SITE FEATURING PRO-
DUCT RATINGS OF THE CONSUMER GOODS OF
OTHERS IN THE FIELD OF COMPUTER SOFTWARE
APPLICATIONS (U.S. CLS. 100, 101 AND 102).

**CLASS 41—EDUCATION AND ENTERTAIN-
MENT**

FOR ENTERTAINMENT SERVICES, NAMELY, PRO-
VIDING ON-LINE REVIEWS OF COMPUTER GAMES
AND COMPUTER SOFTWARE APPLICATIONS (U.S.
CLS. 100, 101 AND 107).

TASNEEM HUSSAIN, EXAMINING ATTORNEY

SN 85-449,162. COMMERCE BANCSHARES, INC., KANSAS CITY, MO. FILED 10-17-2011.

SN 85-449,214. NEWTON RUNNING COMPANY, BOULDER, CO. FILED 10-17-2011.

REMITCONNECT

THE MARK CONSISTS OF STANDARD CHARACTERS WITHOUT CLAIM TO ANY PARTICULAR FONT, STYLE, SIZE, OR COLOR.

OWNER OF U.S. REG. NOS. 1,206,794, 1,864,942 AND 3,743,522.

CLASS 36—INSURANCE AND FINANCIAL

FOR BANKING SERVICES DIRECTED TO THE HEALTHCARE INDUSTRY, NAMELY, EOB MEDICAL REMITTANCE RECEIPT AND PROCESSING, MEDICAL REMITTANCE PAYMENT RECEIPT AND PROCESSING, AND LOCKBOX REMITTANCE PROCESSING SERVICES (U.S. CLS. 100, 101 AND 102).

CLASS 42—SCIENTIFIC AND COMPUTER SERVICES

FOR APPLICATION SERVICE PROVIDER FEATURING SOFTWARE FOR USE IN HEALTHCARE CLAIMS REMITTANCE PROCESSING, NAMELY, AUTOMATED DATA ENTRY, AUTOMATED PAYMENT POSTING, SECONDARY CLAIMS GENERATION AND SUBMISSION, DOCUMENT IMAGING, DOCUMENT AND IMAGE MANAGEMENT, IMAGE STORAGE AND MANAGEMENT, AND IMAGE ARCHIVE AND RETRIEVAL HOSTING SERVICES (U.S. CLS. 100 AND 101).

ALLISON HOLTZ, EXAMINING ATTORNEY

SN 85-449,178. RAEGMEZ LLC, KEY BISCAYNE, FL. FILED 10-17-2011.



OWNER OF U.S. REG. NO. 3,821,452.

THE MARK CONSISTS OF THE WORD "ZEM" IN CAPITAL LETTERS WITH THE PHRASE ZONE OF ENDLESS MOTION AT THE TOP AND A CURVED SEMI-CIRCLE WITH A DOT IN THE TOP LEFT CORNER.

CLASS 18—LEATHER GOODS

FOR BAGS, NAMELY, BACKPACKS (U.S. CLS. 1, 2, 3, 22 AND 41).

FIRST USE 2-1-2010; IN COMMERCE 2-1-2010.

CLASS 25—CLOTHING

FOR FOOTWEAR, NAMELY, ATHLETIC FOOTWEAR AND BEACH FOOTWEAR (U.S. CLS. 22 AND 39).

FIRST USE 10-1-2009; IN COMMERCE 10-1-2009.
DANNEAN HETZEL, EXAMINING ATTORNEY

HELLO BETTER

THE MARK CONSISTS OF STANDARD CHARACTERS WITHOUT CLAIM TO ANY PARTICULAR FONT, STYLE, SIZE, OR COLOR.

CLASS 25—CLOTHING

FOR FOOTWEAR; CLOTHING, NAMELY TOPS, SHORTS, SWEATSHIRTS, T-SHIRTS, HATS, VISORS AND SOCKS (U.S. CLS. 22 AND 39).

CLASS 35—ADVERTISING AND BUSINESS

FOR RETAIL STORE SERVICES IN THE FIELD OF SPORTING GOODS, FOOTWEAR AND APPAREL; ONLINE RETAIL STORE SERVICES IN THE FIELD OF SPORTING GOODS, FOOTWEAR AND APPAREL (U.S. CLS. 100, 101 AND 102).

CLASS 41—EDUCATION AND ENTERTAINMENT

FOR COACHING IN THE FIELD OF SPORTS; CONSULTING SERVICES IN THE FIELDS OF FITNESS AND EXERCISE; EDUCATIONAL SERVICES, NAMELY, DEVELOPING AND CONDUCTING WORKOUTS, WORKSHOPS, DEMONSTRATIONS, AND PRESENTATIONS IN THE FIELDS OF FITNESS AND EXERCISE (U.S. CLS. 100, 101 AND 107).

JENNIFER VASQUEZ, EXAMINING ATTORNEY

SN 85-449,283. SCIENTIFIC FOOD SOLUTIONS, LLC, FAIRFIELD, CA. FILED 10-17-2011.

OUR C IS FASTER THAN YOUR C

THE MARK CONSISTS OF STANDARD CHARACTERS WITHOUT CLAIM TO ANY PARTICULAR FONT, STYLE, SIZE, OR COLOR.

CLASS 1—CHEMICALS

FOR CHEMICAL ADDITIVES FOR USE IN THE MANUFACTURE OF BUFFERED VITAMIN C DIETARY SUPPLEMENTS, NAMELY, CALCIUM CARBONATE, GUM ACACIA, POTASSIUM HYDROXIDE AND MAGNESIUM HYDROXIDE (U.S. CLS. 1, 5, 6, 10, 26 AND 46).

CLASS 5—PHARMACEUTICALS

FOR VITAMIN C PREPARATIONS; CHEMICAL ADDITIVES FOR USE IN THE MANUFACTURE OF BUFFERED VITAMIN C DIETARY SUPPLEMENTS, NAMELY, VITAMIN C (U.S. CLS. 6, 18, 44, 46, 51 AND 52).

MARTHA FROMM, EXAMINING ATTORNEY

SN 85-449,402. CUP TECHNIQUES, LTD., TORONTO, CANADA, FILED 10-18-2011.

LIDS-IN-MOTION

THE MARK CONSISTS OF STANDARD CHARACTERS WITHOUT CLAIM TO ANY PARTICULAR FONT, STYLE, SIZE, OR COLOR.

CLASS 16—PAPER GOODS AND PRINTED MATTER

FOR BIODEGRADABLE PAPER PULP-BASED TO-GO CONTAINERS FOR FOOD; BOXES, CARTONS, STORAGE CONTAINERS, AND PACKAGING CONTAINERS MADE OF PAPER OR CARDBOARD; CARDBOARD CONTAINERS; COMPOSTABLE AND BIODEGRADABLE PAPER PULP-BASED TO-GO CONTAINERS FOR FOOD; CORRUGATED CONTAINERS; PACKAGING CONTAINERS COMPRISED OF PAPERBOARD FOR FOOD AND BEVERAGES; PACKAGING CONTAINERS OF PAPER; PAPER CONTAINERS; PAPER PACKAGING AND CONTAINERS FOR FOOD AND BEVERAGES COMPRISED OF MATERIALS DESIGNED TO LESSEN ADVERSE EFFECTS ON THE ENVIRONMENT (U.S. CLS. 2, 5, 22, 23, 29, 37, 38 AND 50).

CLASS 21—HOUSEWARES AND GLASS

FOR BEAKERS, NAMELY, WIDE-MOUTHED DRINKING CUPS FOR HOUSEHOLD USE; BIODEGRADABLE PAPER PULP-BASED PLATES, BOWLS AND CUPS; CARDBOARD CUPS; COFFEE CUPS; COFFEE CUPS, TEA CUPS AND MUGS; COMPOSTABLE AND BIODEGRADABLE PLATES, BOWLS, CUPS AND TRAYS; CONTAINERS FOR HOUSEHOLD USE; CUPS; CUPS AND MUGS; DRINKING CUPS SOLD WITH LIDS THEREFOR; HOUSEHOLD CONTAINERS FOR FOODS; INSULATED CONTAINERS FOR FOOD OR BEVERAGE FOR DOMESTIC USE; KITCHEN CONTAINERS; NON-MODULAR CONTAINERS FOR USE IN TRANSPORTATION AND STORAGE FOR HOUSEHOLD USE; PAPER CUPS; PLASTIC CONTAINERS, NAMELY, PLASTIC PARTY FAVOR BOXES SOLD EMPTY; PLASTIC CUPS; PORTABLE PLASTIC CONTAINERS FOR STORING HOUSEHOLD AND KITCHEN GOODS; REUSABLE SELF-SEALING LIDS FOR HOUSEHOLD USE FOR BOWLS, CUPS, CONTAINERS AND THE STORAGE OF FOOD; THERMAL INSULATED CONTAINERS FOR FOOD OR BEVERAGES (U.S. CLS. 2, 13, 23, 29, 30, 33, 40 AND 50).

ELISSA GARBER KON, EXAMINING ATTORNEY

SN 85-449,543. SOUTHERN SCRIPTS, LLC, NATCHITOCHES, LA. FILED 10-18-2011.

Southern Scripts

THE MARK CONSISTS OF STANDARD CHARACTERS WITHOUT CLAIM TO ANY PARTICULAR FONT, STYLE, SIZE, OR COLOR.

NO CLAIM IS MADE TO THE EXCLUSIVE RIGHT TO USE "SCRIPTS", APART FROM THE MARK AS SHOWN.

CLASS 35—ADVERTISING AND BUSINESS

FOR ADMINISTERING PHARMACY REIMBURSEMENT PROGRAMS AND SERVICES; COST MANAGEMENT FOR THE HEALTH BENEFIT PLANS OF OTHERS; RETAIL PHARMACY SERVICES (U.S. CLS. 100, 101 AND 102).

FIRST USE 1-1-2011; IN COMMERCE 3-23-2011.

CLASS 36—INSURANCE AND FINANCIAL

FOR PHARMACEUTICAL BENEFIT MANAGEMENT SERVICES; PHARMACY BENEFIT MANAGEMENT SERVICES; PROCESSING, ADMINISTERING AND MANAGING EMPLOYEE BENEFIT PLANS CONCERNING INSURANCE AND FINANCE (U.S. CLS. 100, 101 AND 102).

FIRST USE 1-1-2011; IN COMMERCE 3-23-2011.

CLASS 44—MEDICAL, BEAUTY AND AGRICULTURAL SERVICES

FOR HEALTH CARE SERVICES, NAMELY, WELLNESS PROGRAMS; MANAGED HEALTH CARE SERVICES; PROVIDING ASSISTANCE, FITNESS EVALUATION AND CONSULTATION TO CORPORATE CLIENTS TO HELP THEIR EMPLOYEES MAKE HEALTH, WELLNESS AND NUTRITIONAL CHANGES IN THEIR DAILY LIVING TO IMPROVE HEALTH (U.S. CLS. 100 AND 101).

FIRST USE 1-1-2011; IN COMMERCE 3-23-2011.

JORDAN BAKER, EXAMINING ATTORNEY

SN 85-449,568. SAGGESE, TODD ROBERT, READING, MA. FILED 10-18-2011.

PUT A LID ON

THE MARK CONSISTS OF STANDARD CHARACTERS WITHOUT CLAIM TO ANY PARTICULAR FONT, STYLE, SIZE, OR COLOR.

CLASS 25—CLOTHING

FOR BANDANAS; BELTS FOR CLOTHING; GLOVES AS CLOTHING; HATS; HEADBANDS FOR CLOTHING; JACKETS; JERSEYS; PANTS; SHIRTS; SHORTS; SOCKS; SWEATSHIRTS; T-SHIRTS; TOPS (U.S. CLS. 22 AND 39).

CLASS 35—ADVERTISING AND BUSINESS

FOR ON-LINE RETAIL STORE SERVICES FEATURING HATS AND APPAREL (U.S. CLS. 100, 101 AND 102).

DAVID MURRAY, EXAMINING ATTORNEY

SN 85-449,569. NETOMAT, INC., NEW YORK, NY. FILED 10-18-2011.

JOLLYFY

THE MARK CONSISTS OF STANDARD CHARACTERS WITHOUT CLAIM TO ANY PARTICULAR FONT, STYLE, SIZE, OR COLOR.

CLASS 9—ELECTRICAL AND SCIENTIFIC APPARATUS

FOR COMPUTER APPLICATION SOFTWARE FOR WIRED AND WIRELESS DEVICES THAT ALLOWS USERS TO CUSTOMIZE DIGITAL CONTENT THROUGH MANIPULATING DIGITAL IMAGES, VIDEO, ANIMATION AND TEXT AND THAT CAN BE SHARED VIA E-MAIL, WEBSITE COMMUNITIES AND SOCIAL NETWORKING WEBSITES (U.S. CLS. 21, 23, 26, 36 AND 38).

CLASS 42—SCIENTIFIC AND COMPUTER SERVICES

FOR PROVIDING A WEBSITE FEATURING NON-DOWNLOADABLE SOFTWARE THAT ALLOWS USERS TO CUSTOMIZE DIGITAL CONTENT THROUGH MANIPULATING DIGITAL IMAGES, VIDEO, ANIMATION AND TEXT AND THAT CAN BE SHARED VIA E-MAIL, WEBSITE COMMUNITIES AND SOCIAL NETWORKING WEBSITES (U.S. CLS. 100 AND 101).
JOHN HWANG, EXAMINING ATTORNEY

SN 85-449,571. MISSION HEALTH SYSTEM, INC., ASHEVILLE, NC. FILED 10-18-2011.

MISSION HEALTH

THE MARK CONSISTS OF STANDARD CHARACTERS WITHOUT CLAIM TO ANY PARTICULAR FONT, STYLE, SIZE, OR COLOR.
OWNER OF U.S. REG. NOS. 2,917,751, 3,763,900 AND OTHERS.
NO CLAIM IS MADE TO THE EXCLUSIVE RIGHT TO USE "HEALTH", APART FROM THE MARK AS SHOWN.

CLASS 41—EDUCATION AND ENTERTAINMENT

FOR EDUCATIONAL SERVICES, NAMELY, CONDUCTING CLASSES, SEMINARS AND WORKSHOPS IN THE FIELDS OF HEALTH CARE AND MEDICAL SERVICES (U.S. CLS. 100, 101 AND 107).
FIRST USE 8-1-2011; IN COMMERCE 8-1-2011.

CLASS 44—MEDICAL, BEAUTY AND AGRICULTURAL SERVICES

FOR HEALTH CARE SERVICES; MEDICAL SERVICES (U.S. CLS. 100 AND 101).
FIRST USE 5-20-2011; IN COMMERCE 5-20-2011.
DOMINIC FATHY, EXAMINING ATTORNEY

SN 85-449,599. CONVATEC INC., SKILLMAN, NJ. FILED 10-18-2011.

THE RIGHT DRESSING AT THE RIGHT POINT IN TIME

THE MARK CONSISTS OF STANDARD CHARACTERS WITHOUT CLAIM TO ANY PARTICULAR FONT, STYLE, SIZE, OR COLOR.

CLASS 5—PHARMACEUTICALS

FOR MEDICAL DRESSINGS (U.S. CLS. 6, 18, 44, 46, 51 AND 52).

CLASS 44—MEDICAL, BEAUTY AND AGRICULTURAL SERVICES

FOR MEDICAL INFORMATION (U.S. CLS. 100 AND 101).
JORDAN BAKER, EXAMINING ATTORNEY

SN 85-449,611. TAMELIN PRODUCTIONS, LLC, WORTHINGTON, MA. FILED 10-18-2011.

ANAMANTA

THE MARK CONSISTS OF STANDARD CHARACTERS WITHOUT CLAIM TO ANY PARTICULAR FONT, STYLE, SIZE, OR COLOR.

CLASS 9—ELECTRICAL AND SCIENTIFIC APPARATUS

FOR DIGITAL MATERIALS, NAMELY, DVDS, CDS, AND DOWNLOADABLE AUDIO AND VIDEO RECORDINGS FEATURING INFORMATION IN THE FIELD OF SPIRITUALITY, RELIGION, SELF-IMPROVEMENT, PERSONAL GROWTH, MEDITATION, AND PHILOSOPHY (U.S. CLS. 21, 23, 26, 36 AND 38).

CLASS 16—PAPER GOODS AND PRINTED MATTER

FOR PRINTED MATTER, NAMELY, BOOKS, MANUALS, CURRICULUM, NEWSLETTERS, PAMPHLETS, WORKBOOKS, INFORMATIONAL CARDS, HAND-OUTS, PHOTOGRAPHS, AND BROCHURES IN THE FIELD OF SPIRITUALITY, RELIGION, SELF-IMPROVEMENT, PERSONAL GROWTH, MEDITATION, AND PHILOSOPHY (U.S. CLS. 2, 5, 22, 23, 29, 37, 38 AND 50).

CLASS 41—EDUCATION AND ENTERTAINMENT

FOR EDUCATIONAL SERVICES, NAMELY, WORKSHOPS, COURSES, SEMINARS, CONFERENCES, LECTURES, RETREATS, AND TRAININGS IN THE FIELD OF SPIRITUALITY, RELIGION, SELF-IMPROVEMENT, PERSONAL GROWTH, MEDITATION, AND PHILOSOPHY, AND DISTRIBUTION OF COURSE MATERIALS IN CONNECTION THEREWITH; PROVIDING ONLINE TRAINING, NAMELY, WORKSHOPS, COURSES, SEMINARS, AND LECTURES IN THE FIELD OF SPIRITUALITY, RELIGION, SELF-IMPROVEMENT, PERSONAL GROWTH, MEDITATION, AND PHILOSOPHY; ONLINE PUBLICATION OF BOOKS, PAMPHLETS, WORKBOOKS AND NEWSLETTERS IN THE FIELD OF SPIRITUALITY, RELIGION, SELF-IMPROVEMENT, PERSONAL GROWTH, MEDITATION, AND PHILOSOPHY (U.S. CLS. 100, 101 AND 107).
ODESSA BIBBINS, EXAMINING ATTORNEY

SN 85-449,637. HK WORLDWIDE LLC, NEW YORK, NY.
FILED 10-18-2011.

HOT KISS

THE MARK CONSISTS OF STANDARD CHARACTERS WITHOUT CLAIM TO ANY PARTICULAR FONT, STYLE, SIZE, OR COLOR.

OWNER OF U.S. REG. NOS. 2,696,326 AND 3,117,458.

CLASS 3—COSMETICS AND CLEANING PREPARATIONS

FOR BABY LOTION; BABY OIL; BAR SOAP; BATH CREAM; BATH CRYSTALS; BATH FOAM; BATH GELS; BATH SALTS; BATH SOAPS; BEAUTY CREAMS; BLUSH; BODY CREAM; BODY GLITTER; BODY SPLASH; COLOGNE; COSMETIC CREAMS; COSMETIC OILS; COSMETIC SUNSCREEN PREPARATIONS; COSMETICS; EAU DE COLOGNES; EAU DE PARFUM; EAU DE TOILETTE; ESSENTIAL OILS; EXFOLIANT CREAMS; EYE MAKE-UP; FACE CREAMS; FRAGRANCES; HAIR CARE PREPARATIONS; HAIR GEL AND HAIR MOUSSE; HAIR SHAMPOOS AND CONDITIONERS; HAND CREAMS; HAND LOTIONS; LIP BALM; LIP LINER; LIPSTICK; MAKE-UP; NAIL POLISH; PERFUME; POTPOURRI; SUN BLOCK; SUNSCREEN CREAMS (U.S. CLS. 1, 4, 6, 50, 51 AND 52).

FIRST USE 1-1-2010; IN COMMERCE 1-1-2010.

CLASS 9—ELECTRICAL AND SCIENTIFIC APPARATUS

FOR CAMERAS; CARRYING CASES FOR CELL PHONES; CD PLAYERS; CELLULAR PHONE ACCESSORY CHARMS; CELLULAR PHONES; DIGITAL AUDIO PLAYERS; DIGITAL CAMERAS; DIGITAL CELLULAR PHONES; DVD PLAYERS; EYE GLASSES; FRAMES FOR SPECTACLES AND SUNGLASSES; LAPTOP CARRYING CASES; MP3 PLAYERS; SUNGLASS CHAINS AND CORDS; SUNGLASSES (U.S. CLS. 21, 23, 26, 36 AND 38).

FIRST USE 1-1-2010; IN COMMERCE 1-1-2010.

CLASS 14—JEWELRY

FOR ALARM CLOCKS; ANKLE BRACELETS; BANGLES; BRACELETS; BROACHES; BROOCHES; CHARMS; CHOKERS; CLIP EARRINGS; CLOCKS AND WATCHES; COSTUME JEWELRY; CUFFLINKS; EAR CLIPS; EARRINGS; GEMSTONE JEWELRY; JEWELRY; JEWELRY BOXES; LOCKETS; RINGS; TIE CLIPS; TIMEPIECES; WATCHES (U.S. CLS. 2, 27, 28 AND 50).

FIRST USE 1-1-2010; IN COMMERCE 1-1-2010.

CLASS 18—LEATHER GOODS

FOR ALL-PURPOSE ATHLETIC BAGS; ALL-PURPOSE CARRYING BAGS; ATTACHE CASES; BACKPACKS; BACKPACKS, BOOK BAGS, SPORTS BAGS, BUM BAGS, WALLETS AND HANDBAGS; BEACH BAGS; BOOK BAGS; BRIEFCASES; CARD WALLETS; CARRYALLS; CLUTCH PURSES; COIN PURSES; COSMETIC BAGS SOLD EMPTY; DUFFEL BAGS; GYM BAGS; HANDBAGS; HANDBAGS, PURSES AND WALLETS; KEY WALLETS; LEATHER BAGS AND WALLETS; LEATHER CASES; LEATHER HANDBAGS; LEATHER PURSES; LUGGAGE; POCKET WALLETS; PURSES; PURSES AND WALLETS; SPORTS BAGS; SUITCASES; UMBRELLAS; WALLETS (U.S. CLS. 1, 2, 3, 22 AND 41).

FIRST USE 1-1-2010; IN COMMERCE 1-1-2010.

CLASS 25—CLOTHING

FOR A-SHIRTS; ATHLETIC APPAREL, NAMELY, SHIRTS, PANTS, JACKETS, FOOTWEAR, HATS AND CAPS, ATHLETIC UNIFORMS; BEACHWEAR; BELTS; BLAZERS; BLOUSES; BOARD SHORTS; BOTTOMS; BOXER SHORTS; BUTTON DOWN SHIRTS; CARGO PANTS; CHILDREN'S AND INFANT'S APPAREL, NAMELY, JUMPERS, OVERALL SLEEPWEAR, PAJAMAS, ROMPERS AND ONE-PIECE GARMENTS; CHILDREN'S HEADWEAR; COATS; COATS FOR MEN AND WOMEN; COLLARED SHIRTS; DENIMS; DRESS SHIRTS; DRESSES; FLEECE BOTTOMS; FLEECE PULL-OVERS; FLEECE SHORTS; FLEECE TOPS; FOOTWEAR; GLOVES; GOLF SHIRTS; GOLF SHORTS; GYM SHORTS; HATS; HEADWEAR; HOODED SWEAT SHIRTS; HOSIERY; INFANTWEAR; JACKETS; JEANS; JERSEYS; JOGGING PANTS; KNIT BOTTOMS; KNIT SHIRTS; KNIT TOPS; LADIES' SUITS; LADIES' UNDERWEAR; LEGGINGS; LINGERIE; LOUNGE PANTS; LOUNGEWEAR; NECKWEAR; NIGHTGOWNS; NIGHTWEAR; ONE-PIECE GARMENTS FOR CHILDREN; OUTDOOR GLOVES; OUTER JACKETS; OVER SHIRTS; OVERCOATS; PAJAMAS; PANTIES, SHORTS AND BRIEFS; PANTS; PLAY SUITS; POLO KNIT TOPS; POLO SHIRTS; PONCHOS; RAINCOATS; SCARVES; SHIRTS; SHIRTS FOR INFANTS, BABIES, TODDLERS AND CHILDREN; SHOES; SHORT SETS; SHORTS; SKIRTS; SKIRTS AND DRESSES; SKORTS; SLACKS; SLEEPWEAR; SLIPOVERS; SLIPPERS; SOCKS; SPORT SHIRTS; SPORTS PANTS; SPORTS SHIRTS; SUITS; SWEAT PANTS; SWEAT SHIRTS; SWEAT SHORTS; SWEAT SUITS; SWEATERS; SWEATSHIRTS; SWIMWEAR; T-SHIRTS; TANK TOPS; UNDERWEAR; VESTS (U.S. CLS. 22 AND 39).

FIRST USE 1-1-2010; IN COMMERCE 1-1-2010.

DAWN FELDMAN, EXAMINING ATTORNEY

SN 85-449,661. MILESTONE PROJECT INC., NEW YORK, NY. FILED 10-18-2011.

PLIZY

THE MARK CONSISTS OF STANDARD CHARACTERS WITHOUT CLAIM TO ANY PARTICULAR FONT, STYLE, SIZE, OR COLOR.

CLASS 35—ADVERTISING AND BUSINESS

FOR ADVERTISING, MARKETING AND PROMOTION SERVICES, INCLUDING FACILITATING PARTNERSHIPS BETWEEN AFFILIATES AND MERCHANTS IN CONNECTION WITH MARKETING CAMPAIGNS AND TRANSACTIONS (U.S. CLS. 100, 101 AND 102).

CLASS 38—COMMUNICATION

FOR VIDEO AND VIDEO-ON-DEMAND TRANSMISSION SERVICES; INTERACTIVE DELIVERY OF VIDEO OVER DIGITAL NETWORKS; INTERACTIVE BROADCASTING OF TELEVISION PROGRAMS, MOVIES, MUSIC AND GAMES OVER THE INTERNET AND DIGITAL NETWORKS; ELECTRONIC TRANSMISSION AND STREAMING OF DIGITAL MEDIA CONTENT FOR OTHERS VIA GLOBAL AND LOCAL COMPUTER NETWORKS; TELEVISION PROGRAM BROADCASTING; BROADCASTING SERVICES, NAMELY, TRANSMISSION OF ADVERTISING PROGRAMS AND MEDIA ADVERTISING COMMUNICATIONS VIA DIGITAL COMMUNICATIONS NETWORKS; STREAMING OF AUDIO, VISUAL AND AUDIOVISUAL MATERIAL VIA THE INTERNET; DIGITAL AND ELECTRONIC TRANSMISSION OF VOICE, DATA, IMAGES, SIGNALS AND MESSAGES; PROVIDING ONLINE CHAT ROOMS FOR TRANSMISSION OF MESSAGES AMONG USERS REGARDING MOVIES, MOVIE RATINGS AND REVIEWS, MUSIC, GAMES AND WEB CONTENT; TELECOMMUNICATION SERVICES, NAMELY, TRANSMISSION OF VIDEO, IMAGES, VOICE, AUDIO AND DATA VIA TELEVISION, SATELLITE, CABLE, WIRELESS COMMUNICATION NETWORKS AND THE INTERNET; INTERNET SERVICE PROVIDER (U.S. CLS. 100, 101 AND 104).

CLASS 39—TRANSPORTATION AND STORAGE

FOR ELECTRONIC STORAGE OF TELEVISION PROGRAMS, VIDEOS, MOVIES, MUSIC, GAMES AND WEB CONTENT; TEMPORARY ELECTRONIC STORAGE OF INFORMATION AND DATA (U.S. CLS. 100 AND 105).

CLASS 41—EDUCATION AND ENTERTAINMENT

FOR PROVISION OF NON-DOWNLOADABLE FILMS AND TELEVISION PROGRAMS VIA A VIDEO-ON-DEMAND SERVICE; TELEVISION PROGRAMMING AND PRODUCTION (U.S. CLS. 100, 101 AND 107).

CLASS 42—SCIENTIFIC AND COMPUTER SERVICES

FOR CLOUD COMPUTING FEATURING COMMUNICATION SOFTWARE FOR USE IN PROVIDING TELEVISION PROGRAMS, VIDEOS, FILMS, MUSIC, GAMES AND NEWS, AND SELECTING SAME ACCORDING TO CONSUMER PREFERENCES; PLATFORM AS A SERVICE (PAAS) AND SOFTWARE AS A SERVICE (SAAS) FEATURING COMPUTER SOFTWARE PLATFORMS FOR DELIVERY OF TELEVISION PROGRAMS, VIDEOS, FILMS, MUSIC, GAMES AND NEWS, AND SELECTING SAME ACCORDING TO CONSUMER PREFERENCES (U.S. CLS. 100 AND 101).

CHRISTOPHER SIDOTI, EXAMINING ATTORNEY

SN 85-449,664. BULLY NO MORE, LLC, CHICAGO, IL. FILED 10-18-2011.

BULLY BE GONE

THE MARK CONSISTS OF STANDARD CHARACTERS WITHOUT CLAIM TO ANY PARTICULAR FONT, STYLE, SIZE, OR COLOR.

CLASS 14—JEWELRY

FOR BRACELETS; KEY CHAINS AS JEWELLERY; NECKLACES; RUBBER OR SILICON WRISTBANDS IN THE NATURE OF A BRACELET (U.S. CLS. 2, 27, 28 AND 50).

CLASS 16—PAPER GOODS AND PRINTED MATTER

FOR BUMPER STICKERS; DECALS; FOLDERS; NOTEBOOKS; PENS; STICKERS; TEMPORARY TATTOOS (U.S. CLS. 2, 5, 22, 23, 29, 37, 38 AND 50).

CLASS 25—CLOTHING

FOR BASEBALL CAPS AND HATS; HATS; HOODED SWEATSHIRTS; SHORT-SLEEVED OR LONG-SLEEVED T-SHIRTS; SWEATSHIRTS (U.S. CLS. 22 AND 39).
CHRISTOPHER SIDOTI, EXAMINING ATTORNEY

SN 85-449,682. HK WORLDWIDE LLC, NEW YORK, NY. FILED 10-18-2011.

FIRST KISS

THE MARK CONSISTS OF STANDARD CHARACTERS WITHOUT CLAIM TO ANY PARTICULAR FONT, STYLE, SIZE, OR COLOR.

OWNER OF U.S. REG. NOS. 3,121,386, 3,121,387 AND 3,392,701.

CLASS 3—COSMETICS AND CLEANING PREPARATIONS

FOR BABY LOTION; BABY OIL; BAR SOAP; BATH CREAM; BATH CRYSTALS; BATH FOAM; BATH GELS; BATH SALTS; BATH SOAPS; BEAUTY CREAMS; BLUSH; BODY CREAM; BODY GLITTER; BODY SPLASH; COLOGNE; COSMETIC CREAMS; COSMETIC OILS; COSMETIC SUNSCREEN PREPARATIONS; COSMETICS; EAU DE COLOGNES; EAU DE PARFUM; EAU DE TOILETTE; ESSENTIAL OILS; EXFOLIANT CREAMS; EYE MAKE-UP; FACE CREAMS; FRAGRANCES; HAIR CARE PREPARATIONS; HAIR GEL AND HAIR MOUSSE; HAIR SHAMPOOS AND CONDITIONERS; HAND CREAMS; HAND LOTIONS; LIP BALM; LIP LINER; LIPSTICK; MAKE-UP; NAIL POLISH; PERFUME; POTPOURRI; SUN BLOCK; SUNSCREEN CREAMS (U.S. CLS. 1, 4, 6, 50, 51 AND 52).

FIRST USE 1-1-2010; IN COMMERCE 1-1-2010.

CLASS 9—ELECTRICAL AND SCIENTIFIC APPARATUS

FOR CAMERAS; CARRYING CASES FOR CELL PHONES; CD PLAYERS; CELLULAR PHONE ACCESSORY CHARMS; CELLULAR PHONES; DIGITAL AUDIO PLAYERS; DIGITAL CAMERAS; DIGITAL CELLULAR PHONES; DVD PLAYERS; EYE GLASSES; FRAMES FOR SPECTACLES AND SUNGLASSES; LAPTOP CARRYING CASES; MP3 PLAYERS; SUNGLASS CHAINS AND CORDS; SUNGLASSES (U.S. CLS. 21, 23, 26, 36 AND 38).

FIRST USE 1-1-2010; IN COMMERCE 1-1-2010.

CLASS 14—JEWELRY

FOR ALARM CLOCKS; ANKLE BRACELETS; BANGLES; BRACELETS; BROACHES; BROOCHES; CHARMS; CHOKERS; CLIP EARRINGS; CLOCKS AND WATCHES; COSTUME JEWELRY; CUFFLINKS; EAR CLIPS; EARRINGS; GEMSTONE JEWELRY; JEWELRY; JEWELRY BOXES; LOCKETS; RINGS; TIE CLIPS; TIMEPIECES; WATCHES (U.S. CLS. 2, 27, 28 AND 50).

FIRST USE 1-1-2010; IN COMMERCE 1-1-2010.

SN 85-449,685. FOCUS EDUCATION LLC, HOUSTON, TX.
FILED 10-18-2011.

CLASS 18—LEATHER GOODS

FOR ALL-PURPOSE ATHLETIC BAGS; ALL-PURPOSE CARRYING BAGS; ATTACHE CASES; BACKPACKS; BACKPACKS, BOOK BAGS, SPORTS BAGS, BUM BAGS, WALLETS AND HANDBAGS; BEACH BAGS; BOOK BAGS; BRIEFCASES; CARD WALLETS; CARRYALLS; CLUTCH PURSES; COIN PURSES; COSMETIC BAGS SOLD EMPTY; DUFFEL BAGS; GYM BAGS; HANDBAGS; HANDBAGS, PURSES AND WALLETS; KEY WALLETS; LEATHER BAGS AND WALLETS; LEATHER CASES; LEATHER HANDBAGS; LEATHER PURSES; LUGGAGE; POCKET WALLETS; PURSES; PURSES AND WALLETS; SPORTS BAGS; SUITCASES; UMBRELLAS; WALLETS (U.S. CLS. 1, 2, 3, 22 AND 41).

FIRST USE 1-1-2010; IN COMMERCE 1-1-2010.



THE MARK CONSISTS OF THE OUTLINE OF THE WORDS FORMING "JUNGLE RANGERS" WITH THE APPEARANCE OF BEING CARVED FROM STONE.

CLASS 25—CLOTHING

FOR A-SHIRTS; ATHLETIC APPAREL, NAMELY, SHIRTS, PANTS, JACKETS, FOOTWEAR, HATS AND CAPS, ATHLETIC UNIFORMS; BEACHWEAR; BELTS; BLAZERS; BLOUSES; BOARD SHORTS; BOTTOMS; BOXER SHORTS; BUTTON DOWN SHIRTS; CARGO PANTS; CHILDREN'S AND INFANT'S APPAREL, NAMELY, JUMPERS, OVERALL SLEEPWEAR, PAJAMAS, ROMPERS AND ONE-PIECE GARMENTS; CHILDREN'S HEADWEAR; COATS; COATS FOR MEN AND WOMEN; COLLARED SHIRTS; DENIMS; DRESS SHIRTS; DRESSES; FLEECE BOTTOMS; FLEECE PULL-OVERS; FLEECE SHORTS; FLEECE TOPS; FOOTWEAR; GLOVES; GOLF SHIRTS; GOLF SHORTS; GYM SHORTS; HATS; HEADWEAR; HOODED SWEAT SHIRTS; HOSIERY; INFANTWEAR; JACKETS; JEANS; JERSEYS; JOGGING PANTS; KNIT BOTTOMS; KNIT SHIRTS; KNIT TOPS; LADIES' SUITS; LADIES' UNDERWEAR; LEGGINGS; LINGERIE; LOUNGE PANTS; LOUNGEWEAR; NECKWEAR; NIGHTGOWNS; NIGHTWEAR; ONE-PIECE GARMENTS FOR CHILDREN; OUTDOOR GLOVES; OUTER JACKETS; OVER SHIRTS; OVERCOATS; PAJAMAS; PANTIES, SHORTS AND BRIEFS; PANTS; PLAY SUITS; POLO KNIT TOPS; POLO SHIRTS; PONCHOS; RAINCOATS; SCARVES; SHIRTS; SHIRTS FOR INFANTS, BABIES, TODDLERS AND CHILDREN; SHOES; SHORT SETS; SHORTS; SKIRTS; SKIRTS AND DRESSES; SKORTS; SLACKS; SLEEPWEAR; SLIPOVERS; SLIPPERS; SOCKS; SPORT SHIRTS; SPORTS PANTS; SPORTS SHIRTS; SUITS; SWEAT PANTS; SWEAT SHIRTS; SWEAT SHORTS; SWEAT SUITS; SWEATERS; SWEATSHIRTS; SWIMWEAR; T-SHIRTS; TANK TOPS; UNDERWEAR; VESTS (U.S. CLS. 22 AND 39).

FIRST USE 1-1-2010; IN COMMERCE 1-1-2010.
DAWN FELDMAN, EXAMINING ATTORNEY

CLASS 9—ELECTRICAL AND SCIENTIFIC APPARATUS

FOR EDUCATIONAL PRODUCTS FOR CHILDREN IN THE NATURE OF SOFTWARE, CDS AND DVDS, ALL FEATURING EXERCISES AND ACTIVITIES FOR FOCUS AND ATTENTION BUILDING (U.S. CLS. 21, 23, 26, 36 AND 38).

CLASS 16—PAPER GOODS AND PRINTED MATTER

FOR EDUCATIONAL PRODUCTS FOR CHILDREN IN THE NATURE OF WORKBOOKS, ALL FEATURING EXERCISES AND ACTIVITIES FOR FOCUS AND ATTENTION BUILDING (U.S. CLS. 2, 5, 22, 23, 29, 37, 38 AND 50).

CLASS 41—EDUCATION AND ENTERTAINMENT

FOR EDUCATIONAL PRODUCTS FOR CHILDREN IN THE NATURE OF ON-LINE GAMES AND ONLINE NON-DOWNLOADABLE WORKBOOKS FEATURING EXERCISES AND ACTIVITIES FOR FOCUS AND ATTENTION BUILDING (U.S. CLS. 100, 101 AND 107).

CLASS 42—SCIENTIFIC AND COMPUTER SERVICES

FOR PROVIDING TEMPORARY USE OF ONLINE, NON-DOWNLOADABLE SOFTWARE FEATURING EXERCISES AND ACTIVITIES FOR FOCUS AND ATTENTION BUILDING (U.S. CLS. 100 AND 101).
KIMBERLY FRYE, EXAMINING ATTORNEY

SN 85-449,703. FOCUS EDUCATION, LLC, HOUSTON, TX. FILED 10-18-2011.

SN 85-449,707. FOCUS EDUCATION, LLC, HOUSTON, TX. FILED 10-18-2011.



THE MARK CONSISTS OF A STYLIZED DESIGN OF A BOY.

CLASS 9—ELECTRICAL AND SCIENTIFIC APPARATUS

FOR EDUCATIONAL PRODUCTS FOR CHILDREN IN THE NATURE OF SOFTWARE, CDS AND DVDS, ALL FEATURING EXERCISES AND ACTIVITIES FOR FOCUS AND ATTENTION BUILDING (U.S. CLS. 21, 23, 26, 36 AND 38).

CLASS 16—PAPER GOODS AND PRINTED MATTER

FOR EDUCATIONAL PRODUCTS FOR CHILDREN IN THE NATURE OF WORKBOOKS, ALL FEATURING EXERCISES AND ACTIVITIES FOR FOCUS AND ATTENTION BUILDING (U.S. CLS. 2, 5, 22, 23, 29, 37, 38 AND 50).

CLASS 41—EDUCATION AND ENTERTAINMENT

FOR EDUCATIONAL PRODUCTS FOR CHILDREN IN THE NATURE OF ON-LINE GAMES AND ONLINE NON-DOWNLOADABLE WORKBOOKS FEATURING EXERCISES AND ACTIVITIES FOR FOCUS AND ATTENTION BUILDING (U.S. CLS. 100, 101 AND 107).

CLASS 42—SCIENTIFIC AND COMPUTER SERVICES

FOR PROVIDING TEMPORARY USE OF ONLINE, NON-DOWNLOADABLE SOFTWARE FEATURING EXERCISES AND ACTIVITIES FOR FOCUS AND ATTENTION BUILDING (U.S. CLS. 100 AND 101). LIEF MARTIN, EXAMINING ATTORNEY



THE MARK CONSISTS OF A STYLIZED DESIGN OF A GIRL.

CLASS 9—ELECTRICAL AND SCIENTIFIC APPARATUS

FOR EDUCATIONAL PRODUCTS FOR CHILDREN IN THE NATURE OF SOFTWARE, CDS AND DVDS, ALL FEATURING EXERCISES AND ACTIVITIES FOR FOCUS AND ATTENTION BUILDING (U.S. CLS. 21, 23, 26, 36 AND 38).

CLASS 16—PAPER GOODS AND PRINTED MATTER

FOR EDUCATIONAL PRODUCTS FOR CHILDREN IN THE NATURE OF WORKBOOKS, ALL FEATURING EXERCISES AND ACTIVITIES FOR FOCUS AND ATTENTION BUILDING (U.S. CLS. 2, 5, 22, 23, 29, 37, 38 AND 50).

CLASS 41—EDUCATION AND ENTERTAINMENT

FOR EDUCATIONAL PRODUCTS FOR CHILDREN IN THE NATURE OF ON-LINE GAMES AND ONLINE NON-DOWNLOADABLE WORKBOOKS FEATURING EXERCISES AND ACTIVITIES FOR FOCUS AND ATTENTION BUILDING (U.S. CLS. 100, 101 AND 107).

CLASS 42—SCIENTIFIC AND COMPUTER SERVICES

FOR PROVIDING TEMPORARY USE OF ONLINE, NON-DOWNLOADABLE SOFTWARE FEATURING EXERCISES AND ACTIVITIES FOR FOCUS AND ATTENTION BUILDING (U.S. CLS. 100 AND 101). LIEF MARTIN, EXAMINING ATTORNEY

SN 85-449,746. HK WORLDWIDE LLC, NEW YORK, NY. FILED 10-18-2011.

HOT KISS



OWNER OF U.S. REG. NOS. 2,696,326 AND 3,117,458.

THE MARK CONSISTS OF THE WORDS "HOT KISS" WITH LIPS UNDERNEATH.

CLASS 3—COSMETICS AND CLEANING PREPARATIONS

FOR BABY LOTION; BABY OIL; BAR SOAP; BATH CREAM; BATH CRYSTALS; BATH FOAM; BATH GELS; BATH SALTS; BATH SOAPS; BEAUTY CREAMS; BLUSH; BODY CREAM; BODY GLITTER; BODY SPLASH; COLOGNE; COSMETIC CREAMS; COSMETIC OILS; COSMETIC SUNSCREEN PREPARATIONS; COSMETICS; EAU DE COLOGNES; EAU DE PARFUM; EAU DE TOILETTE; ESSENTIAL OILS; EXFOLIANT CREAMS; EYE MAKE-UP; FACE CREAMS; FRAGRANCES; HAIR CARE PREPARATIONS; HAIR GEL AND HAIR MOUSSE; HAIR SHAMPOOS AND CONDITIONERS; HAND CREAMS; HAND LOTIONS; LIP BALM; LIP LINER; LIPSTICK; MAKE-UP; NAIL POLISH; PERFUME; POTPOURRI; SUN BLOCK; SUNSCREEN CREAMS (U.S. CLS. 1, 4, 6, 50, 51 AND 52).

FIRST USE 1-1-2010; IN COMMERCE 1-1-2010.

CLASS 9—ELECTRICAL AND SCIENTIFIC APPARATUS

FOR CAMERAS; CARRYING CASES FOR CELL PHONES; CD PLAYERS; CELLULAR PHONE ACCESSORY CHARMS; CELLULAR PHONES; DIGITAL AUDIO PLAYERS; DIGITAL CAMERAS; DIGITAL CELLULAR PHONES; DVD PLAYERS; EYE GLASSES; FRAMES FOR SPECTACLES AND SUNGLASSES; LAPTOP CARRYING CASES; MP3 PLAYERS; SUNGLASS CHAINS AND CORDS; SUNGLASSES (U.S. CLS. 21, 23, 26, 36 AND 38).

FIRST USE 1-1-2010; IN COMMERCE 1-1-2010.

CLASS 14—JEWELRY

FOR ALARM CLOCKS; ANKLE BRACELETS; BANGLES; BRACELETS; BROOCHES; CHARMS; CHOKERS; CLIP EARRINGS; CLOCKS AND WATCHES; COSTUME JEWELRY; CUFFLINKS; EAR CLIPS; EARRINGS; GEMSTONE JEWELRY; JEWELRY; JEWELRY BOXES; LOCKETS; RINGS; TIE CLIPS; TIMEPIECES; WATCHES (U.S. CLS. 2, 27, 28 AND 50).

FIRST USE 1-1-2010; IN COMMERCE 1-1-2010.

CLASS 18—LEATHER GOODS

FOR ALL-PURPOSE ATHLETIC BAGS; ALL-PURPOSE CARRYING BAGS; ATTACHE CASES; BACKPACKS; BACKPACKS, BOOK BAGS, SPORTS BAGS, BUM BAGS, WALLETS AND HANDBAGS; BEACH BAGS; BOOK BAGS; BRIEFCASES; CARD WALLETS; CARRYALLS; CLUTCH PURSES; COIN PURSES; COSMETIC BAGS SOLD EMPTY; DUFFEL BAGS; GYM BAGS; HANDBAGS; HANDBAGS, PURSES AND WALLETS; KEY WALLETS; LEATHER BAGS AND WALLETS; LEATHER CASES; LEATHER HANDBAGS; LEATHER PURSES; LUGGAGE; POCKET WALLETS; PURSES; PURSES AND WALLETS; SPORTS BAGS; SUITCASES; UMBRELLAS; WALLETS (U.S. CLS. 1, 2, 3, 22 AND 41).

FIRST USE 1-1-2010; IN COMMERCE 1-1-2010.

CLASS 25—CLOTHING

FOR A-SHIRTS; ATHLETIC APPAREL, NAMELY, SHIRTS, PANTS, JACKETS, FOOTWEAR, HATS AND CAPS, ATHLETIC UNIFORMS; BEACHWEAR; BELTS; BLAZERS; BLOUSES; BOARD SHORTS; BOTTOMS; BOXER SHORTS; BUTTON DOWN SHIRTS; CARGO PANTS; CHILDREN'S AND INFANT'S APPAREL, NAMELY, JUMPERS, OVERALL SLEEPWEAR, PAJAMAS, ROMPERS AND ONE-PIECE GARMENTS; CHILDREN'S HEADWEAR; COATS; COATS FOR MEN AND WOMEN; COLLARED SHIRTS; DENIMS; DRESS SHIRTS; DRESSES; FLEECE BOTTOMS; FLEECE PULL-OVERS; FLEECE SHORTS; FLEECE TOPS; FOOTWEAR; GLOVES; GOLF SHIRTS; GOLF SHORTS; GYM SHORTS; HATS; HEADWEAR; HOODED SWEAT SHIRTS; HOSIERY; INFANTWEAR; JACKETS; JEANS; JERSEYS; JOGGING PANTS; KNIT BOTTOMS; KNIT SHIRTS; KNIT TOPS; LADIES' SUITS; LADIES' UNDERWEAR; LEG-

TINGS; LINGERIE; LOUNGE PANTS; LOUNGEWEAR; NECKWEAR; NIGHTGOWNS; NIGHTWEAR; ONE-PIECE GARMENTS FOR CHILDREN; OUTDOOR GLOVES; OUTER JACKETS; OVER SHIRTS; OVERCOATS; PAJAMAS; PANTIES, SHORTS AND BRIEFS; PANTS; PLAY SUITS; POLO KNIT TOPS; POLO SHIRTS; PONCHOS; RAINCOATS; SCARVES; SHIRTS; SHIRTS FOR INFANTS, BABIES, TODDLERS AND CHILDREN; SHOES; SHORT SETS; SHORTS; SKIRTS; SKIRTS AND DRESSES; SKORTS; SLACKS; SLEEPWEAR; SLIPOVERS; SLIPPERS; SOCKS; SPORT SHIRTS; SPORTS PANTS; SPORTS SHIRTS; SUITS; SWEAT PANTS; SWEAT SHIRTS; SWEAT SHORTS; SWEAT SUITS; SWEATERS; SWEATSHIRTS; SWIMWEAR; T-SHIRTS; TANK TOPS; UNDERWEAR; VESTS (U.S. CLS. 22 AND 39).

FIRST USE 1-1-2010; IN COMMERCE 1-1-2010.
DAWN FELDMAN, EXAMINING ATTORNEY

SN 85-449,761. A. MALEH & SONS LLC, NEW YORK, NY. FILED 10-18-2011.

BELLMAN'S ALLWEATHER

THE MARK CONSISTS OF STANDARD CHARACTERS WITHOUT CLAIM TO ANY PARTICULAR FONT, STYLE, SIZE, OR COLOR.

NO CLAIM IS MADE TO THE EXCLUSIVE RIGHT TO USE "ALLWEATHER", APART FROM THE MARK AS SHOWN.

CLASS 14—JEWELRY

FOR JEWELRY (U.S. CLS. 2, 27, 28 AND 50).

CLASS 18—LEATHER GOODS

FOR BRIEFCASES; LUGGAGE; BACKPACKS; WALLETS; BILLFOLDS (U.S. CLS. 1, 2, 3, 22 AND 41).

CLASS 25—CLOTHING

FOR CLOTHING, NAMELY, TOPS; PANTS; JACKETS; COATS; BELTS; HEADWEAR; HATS; SHOES; FOOTWEAR (U.S. CLS. 22 AND 39).

CLASS 35—ADVERTISING AND BUSINESS

FOR ON-LINE RETAIL STORE SERVICES FEATURING CLOTHING, JEWELRY, LEATHER GOODS, AND WATCHES; RETAIL STORE SERVICES FEATURING CLOTHING, JEWELRY, LEATHER GOODS, AND WATCHES (U.S. CLS. 100, 101 AND 102).

CHRISTINE MARTIN, EXAMINING ATTORNEY

SN 85-449,777. A. MALEH & SONS LLC, NEW YORK, NY. FILED 10-18-2011.

A. MALEH & SONS

THE MARK CONSISTS OF STANDARD CHARACTERS WITHOUT CLAIM TO ANY PARTICULAR FONT, STYLE, SIZE, OR COLOR.

THE NAME "A. MALEH" IDENTIFIES A LIVING INDIVIDUAL WHOSE CONSENT IS OF RECORD.

SN 85-449,800. KEVIN FORD, GRAHAM, GAUTENG, SOUTH AFRICA, FILED 10-18-2011.

CLASS 9—ELECTRICAL AND SCIENTIFIC APPARATUS

FOR EYEWEAR; SUNGLASSES (U.S. CLS. 21, 23, 26, 36 AND 38).

CLASS 14—JEWELRY

FOR JEWELRY (U.S. CLS. 2, 27, 28 AND 50).

CLASS 18—LEATHER GOODS

FOR BRIEFCASES; LUGGAGE; BACKPACKS; WALLET; BILLFOLDS (U.S. CLS. 1, 2, 3, 22 AND 41).

CLASS 25—CLOTHING

FOR CLOTHING, NAMELY, TOPS; PANTS; JACKETS; COATS; BELTS; HEADWEAR; HATS; SHOES; FOOTWEAR (U.S. CLS. 22 AND 39).

CLASS 35—ADVERTISING AND BUSINESS

FOR ON-LINE RETAIL STORE SERVICES FEATURING CLOTHING, JEWELRY, LEATHER GOODS, CLASSIC CARS, EYEWEAR, AND WATCHES; RETAIL STORE SERVICES FEATURING CLOTHING, JEWELRY, LEATHER GOODS, CLASSIC CARS, EYEWEAR, AND WATCHES (U.S. CLS. 100, 101 AND 102).

CHRISTINE MARTIN, EXAMINING ATTORNEY

SN 85-449,795. HEARTSPUN QUILTS, INC., MOKENA, IL. FILED 10-18-2011.

HEARTSPUN QUILTS

THE MARK CONSISTS OF STANDARD CHARACTERS WITHOUT CLAIM TO ANY PARTICULAR FONT, STYLE, SIZE, OR COLOR.

NO CLAIM IS MADE TO THE EXCLUSIVE RIGHT TO USE "QUILTS", APART FROM THE MARK AS SHOWN.

CLASS 16—PAPER GOODS AND PRINTED MATTER

FOR PATTERNS AND PRINTED INSTRUCTIONAL MATERIALS FOR QUILT MAKING (U.S. CLS. 2, 5, 22, 23, 29, 37, 38 AND 50).

FIRST USE 5-31-2009; IN COMMERCE 5-31-2009.

CLASS 41—EDUCATION AND ENTERTAINMENT

FOR EDUCATION SERVICES, NAMELY, DEVELOPING AND PROVIDING WORKSHOPS, CLASSES, AND LECTURES IN THE FIELD OF QUILT MAKING AND DISTRIBUTING PRINTED MATERIAL IN CONNECTION THEREWITH (U.S. CLS. 100, 101 AND 107).

FIRST USE 12-15-2010; IN COMMERCE 12-15-2010.
CARRIE GENOVESE, EXAMINING ATTORNEY



THE MARK CONSISTS OF THE LETTER B SURROUNDED AT ITS MIDDLE WITH ARROWS.

CLASS 9—ELECTRICAL AND SCIENTIFIC APPARATUS

FOR COMPUTER SOFTWARE FOR THE COLLECTION, EDITING, ORGANIZING, MODIFYING, BOOK MARKING, TRANSMISSION, STORAGE AND SHARING OF DATA AND INFORMATION IN THE FIELDS OF BUSINESS, MARKETING OF GOODS AND SERVICES, COMMUNITY NETWORKING, RECRUITMENT AND EMPLOYMENT (U.S. CLS. 21, 23, 26, 36 AND 38).

CLASS 42—SCIENTIFIC AND COMPUTER SERVICES

FOR PROVIDING TEMPORARY USE OF ON-LINE NON-DOWNLOADABLE SOFTWARE FOR ALLOWING WEB SITE USERS TO COMMUNICATE INFORMATION OF GENERAL INTEREST FOR PURPOSES OF BUSINESS, MARKETING OF GOODS AND SERVICES, COMMUNITY NETWORKING, RECRUITMENT AND EMPLOYMENT; PROVIDING A WEBSITE FEATURING TEMPORARY USE OF NON-DOWNLOADABLE SOFTWARE ENABLING USERS TO SEARCH, LOCATE AND COMMUNICATE WITH OTHERS VIA ELECTRONIC COMMUNICATIONS NETWORKS (U.S. CLS. 100 AND 101).

CHARLES L. JENKINS, EXAMINING ATTORNEY

SN 85-449,840. BRADLEY BIDDICK, LIVINGSTON, WI. FILED 10-18-2011.

gWill

THE MARK CONSISTS OF STANDARD CHARACTERS WITHOUT CLAIM TO ANY PARTICULAR FONT, STYLE, SIZE, OR COLOR.

CLASS 16—PAPER GOODS AND PRINTED MATTER

FOR PRINTED CERTIFICATES (U.S. CLS. 2, 5, 22, 23, 29, 37, 38 AND 50).

CLASS 38—COMMUNICATION

FOR WEB MESSAGING (U.S. CLS. 100, 101 AND 104).
GINA HAYES, EXAMINING ATTORNEY

SN 85-449,842. NIKAO CORPORATION, OVERLAND PARK, KS. FILED 10-18-2011.

NIKAO

THE MARK CONSISTS OF STANDARD CHARACTERS WITHOUT CLAIM TO ANY PARTICULAR FONT, STYLE, SIZE, OR COLOR.

CLASS 35—ADVERTISING AND BUSINESS

FOR BUSINESS DEVELOPMENT SERVICES; BUSINESS MANAGEMENT AND CONSULTATION; BUSINESS STRATEGY DEVELOPMENT SERVICES (U.S. CLS. 100, 101 AND 102).

CLASS 42—SCIENTIFIC AND COMPUTER SERVICES

FOR COMPUTER SOFTWARE CONSULTING; COMPUTER SOFTWARE DEVELOPMENT (U.S. CLS. 100 AND 101).
JOHN HWANG, EXAMINING ATTORNEY

SN 85-449,850. PEAK HEALTH SOLUTIONS, INC., SAN DIEGO, CA. FILED 10-18-2011.

PEAK HEALTH SOLUTIONS

THE MARK CONSISTS OF STANDARD CHARACTERS WITHOUT CLAIM TO ANY PARTICULAR FONT, STYLE, SIZE, OR COLOR.

NO CLAIM IS MADE TO THE EXCLUSIVE RIGHT TO USE "HEALTH SOLUTIONS", APART FROM THE MARK AS SHOWN.

CLASS 35—ADVERTISING AND BUSINESS

FOR BUSINESS INFORMATION MANAGEMENT SERVICES, NAMELY, PROCEDURE AND MEDICATION CODING, BUSINESS AUDITING, AND MONITORING COMPLIANCE OF INSURANCE CLAIMS REGULATIONS AND FINANCIAL RECORD KEEPING FOR HEALTHCARE FACILITIES, HEALTHCARE ORGANIZATIONS AND HEALTH INSURANCE PLANS (U.S. CLS. 100, 101 AND 102).

FIRST USE 1-1-2004; IN COMMERCE 1-1-2004.

CLASS 41—EDUCATION AND ENTERTAINMENT

FOR EDUCATIONAL SERVICES FOR PHYSICIANS, HEALTHCARE AND HEALTH INSURANCE PERSONNEL, NAMELY, PROVIDING COURSES OF INSTRUCTION, SEMINARS AND WORKSHOPS FEATURING MEDICAL RECORDS MANAGEMENT, MEDICAL INFORMATION SECURITY, MONITORING WORKFLOW OF MEDICAL CODERS FOR INSURANCE BILLING, AND HEALTHCARE FACILITY MANAGEMENT AND OPERATION (U.S. CLS. 100, 101 AND 107).

FIRST USE 1-1-2004; IN COMMERCE 1-1-2004.

CLASS 42—SCIENTIFIC AND COMPUTER SERVICES

FOR PROVIDING CONSULTATION IN THE FIELD OF COMPUTER TECHNOLOGY AND SOFTWARE FOR MEDICAL RECORD MANAGEMENT, MEDICAL INFORMATION SECURITY, MONITORING WORKFLOW OF MEDICAL CODERS FOR INSURANCE BILLING, AND HEALTHCARE FACILITY MANAGEMENT AND OPERATION (U.S. CLS. 100 AND 101).

FIRST USE 1-1-2004; IN COMMERCE 1-1-2004.

BARBARA A. GOLD, EXAMINING ATTORNEY

SN 85-449,852. UHS OF DELAWARE, INC., KING OF PRUSSIA, PA. FILED 10-18-2011.

FOR BETTER HEALTH

THE MARK CONSISTS OF A DEPICTION OF A FLOWER ABOVE THE WORDS "WE WOMEN ENLIGHTENED FOR BETTER HEALTH".

CLASS 41—EDUCATION AND ENTERTAINMENT

FOR EDUCATION SERVICES, NAMELY, PROVIDING SEMINARS IN THE FIELD OF WOMEN'S HEALTH (U.S. CLS. 100, 101 AND 107).

CLASS 44—MEDICAL, BEAUTY AND AGRICULTURAL SERVICES

FOR HEALTHCARE (U.S. CLS. 100 AND 101).
JAY FLOWERS, EXAMINING ATTORNEY

SN 85-449,859. GRAMMARLY, INC., SAN FRANCISCO, CA. FILED 10-18-2011.

GRAMMARLY

THE MARK CONSISTS OF STANDARD CHARACTERS WITHOUT CLAIM TO ANY PARTICULAR FONT, STYLE, SIZE, OR COLOR.

CLASS 9—ELECTRICAL AND SCIENTIFIC APPARATUS

FOR DOWNLOADABLE PLUG-IN SOFTWARE FOR USE AND INSTRUCTION IN PROOFREADING TEXT, PROVIDING CITATIONS IN TEXT, DETECTING PLAGIARISM IN TEXT, APPLYING RULES OF GRAMMAR AND PUNCTUATION TO TEXT, CHECKING THE SPELLING OF TEXT, EDITING TEXT, ENHANCING THE VOCABULARY OF THE USER BY PROVIDING WORD CHOICE SUGGESTIONS AND PROVIDING REPORTS THAT CONTAIN DESCRIPTIONS AND EXPLANATIONS OF ERRORS AND IMPROVEMENTS (U.S. CLS. 21, 23, 26, 36 AND 38).

FIRST USE 4-30-2010; IN COMMERCE 4-30-2010.

CLASS 41—EDUCATION AND ENTERTAINMENT

FOR EDUCATIONAL SERVICES, NAMELY, PROVIDING COMPUTERIZED INSTRUCTION IN THE NATURE OF PROOFREADING TEXT, PROVIDING CITATIONS IN TEXT, APPLYING RULES OF GRAMMAR AND PUNCTUATION TO TEXT, THE SPELLING OF TEXT, EDITING TEXT, AND ENHANCING VOCABULARY, THROUGH THE USE OF AUTOMATED REPORTS CONTAINING DESCRIPTIONS AND EXPLANATIONS OF ERRORS AND IMPROVEMENTS (U.S. CLS. 100, 101 AND 107).

FIRST USE 12-7-2009; IN COMMERCE 12-7-2009.

CLASS 42—SCIENTIFIC AND COMPUTER SERVICES

FOR SOFTWARE AS A SERVICE (SAAS) SERVICES FEATURING SOFTWARE FOR USE AND INSTRUCTION IN PROOFREADING TEXT, PROVIDING CITATIONS IN TEXT, DETECTING PLAGIARISM IN TEXT, APPLYING RULES OF GRAMMAR AND PUNCTUATION TO TEXT, CHECKING THE SPELLING OF TEXT, EDITING TEXT, ENHANCING THE VOCABULARY OF THE USER BY PROVIDING WORD CHOICE SUGGESTIONS AND PROVIDING REPORTS THAT CONTAIN DESCRIPTIONS AND EXPLANATIONS OF ERRORS AND IMPROVEMENTS; PROVIDING A WEBSITE FEATURING NON-DOWNLOADABLE SOFTWARE FOR USE AND INSTRUCTION IN PROOFREADING TEXT, PROVIDING CITATIONS IN TEXT, DETECTING PLAGIARISM IN TEXT, APPLYING RULES OF GRAMMAR AND PUNCTUATION TO TEXT, CHECKING THE SPELLING OF TEXT, EDITING TEXT, ENHANCING THE VOCABULARY OF THE USER BY PROVIDING WORD CHOICE SUGGESTIONS AND PROVIDING REPORTS THAT CONTAIN DESCRIPTIONS AND EXPLANATIONS OF ERRORS AND IMPROVEMENTS (U.S. CLS. 100 AND 101).

FIRST USE 12-7-2009; IN COMMERCE 12-7-2009.
JAY FLOWERS, EXAMINING ATTORNEY

CLASS 35—ADVERTISING AND BUSINESS

FOR PROMOTING THE GOODS OF OTHERS, NAMELY, GRAIN MARKETING SERVICES FOR AGRICULTURAL PRODUCERS OF WHEAT, OATS, BARLEY, CORN, SOYBEANS, AND GRAINS FOR ANIMAL FEED; WHOLESALE DISTRIBUTORSHIP SERVICES OF GRAIN IN THE NATURE OF CORN, SOYBEANS, WHEAT, OATS AND BARLEY, AND PETROLEUM PRODUCTS IN THE NATURE OF GASOLINE, DIESEL FUEL, LIGHT DISTILLATE HEATING OIL, PROPANE, AND LUBRICANTS; RETAIL DISTRIBUTORSHIP SERVICES FOR ANIMAL FEED, AGRICULTURAL SEED, AGRICULTURAL FERTILIZER, AGRICULTURAL CHEMICALS, GASOLINE, DIESEL FUEL, LIGHT DISTILLATE HEATING OIL AND PROPANE; RETAIL STORES FEATURING FARM SUPPLIES IN THE NATURE OF (A) FENCE, ANIMAL FEEDERS, WORK CLOTHING, AND LIVESTOCK HOUSING, (B) PACKAGED ANIMAL FEED, AGRICULTURAL CHEMICALS, SEED, AND FERTILIZER, (C) PETROLEUM PRODUCTS IN THE NATURE OF KEROSENE, PROPANE, AND LUBRICANTS, AND (D) TOOLS AND HARDWARE RELATED TO THESE FARM SUPPLIES; AND AGRICULTURAL BUSINESS CONSULTATION, NAMELY, PROVIDING INFORMATION ON PRODUCTION AND MARKETING OF AGRICULTURAL COMMODITIES (U.S. CLS. 100, 101 AND 102).

CLASS 39—TRANSPORTATION AND STORAGE

FOR BULK DELIVERY OF GASOLINE, DIESEL FUEL, LIGHT DISTILLATE HEATING OIL, PROPANE, AND PETROLEUM PRODUCTS TO AGRICULTURAL, COMMERCIAL, AND RESIDENTIAL CUSTOMERS; BULK DELIVERY OF CROP INPUT PRODUCTS TO AGRICULTURAL CUSTOMERS; TRANSPORTATION OF GRAIN, ANIMAL FEED, FARM SUPPLY PRODUCTS, AND PROCESSED AGRICULTURAL COMMODITIES; GRAIN STORAGE FOR AGRICULTURAL PRODUCERS OF WHEAT, OATS, BARLEY, AND OTHER SMALL GRAINS AND CORN, SOYBEANS, AND OTHER FEED GRAINS; WAREHOUSING SERVICES, NAMELY, GRAIN HANDLING SERVICES FOR AGRICULTURAL PRODUCERS OF WHEAT, OATS, BARLEY, AND OTHER SMALL GRAINS AND CORN, SOYBEANS, AND OTHER FEED GRAINS (U.S. CLS. 100 AND 105).

MARK RADEMACHER, EXAMINING ATTORNEY

SN 85-449,916. UNITED LANDMARK, LLC, XENIA, OH.
FILED 10-18-2011.

SN 85-449,932. HEARTSPUN QUILTS, INC., MOKENA, IL.
FILED 10-18-2011.

GROWING THE CURE

THE MARK CONSISTS OF STANDARD CHARACTERS WITHOUT CLAIM TO ANY PARTICULAR FONT, STYLE, SIZE, OR COLOR.

CLASS 31—NATURAL AGRICULTURAL PRODUCTS

FOR ANIMAL FEEDS, NAMELY, FEEDS FOR LIVESTOCK AND POULTRY; UNPROCESSED CORN, SOYBEANS, ALFALFA, UNPROCESSED WHEAT, OATS, AND BARLEY SOLD IN BULK; AGRICULTURAL SEEDS; WILD BIRD FEED (U.S. CLS. 1 AND 46).

PRAIRIE WOMEN'S SEWING CIRCLE

THE MARK CONSISTS OF STANDARD CHARACTERS WITHOUT CLAIM TO ANY PARTICULAR FONT, STYLE, SIZE, OR COLOR.

NO CLAIM IS MADE TO THE EXCLUSIVE RIGHT TO USE "SEWING CIRCLE", APART FROM THE MARK AS SHOWN.

CLASS 16—PAPER GOODS AND PRINTED MATTER

FOR PATTERNS AND PRINTED INSTRUCTIONAL MATERIALS FOR QUILT MAKING (U.S. CLS. 2, 5, 22, 23, 29, 37, 38 AND 50).

FIRST USE 1-31-2010; IN COMMERCE 1-31-2010.

CLASS 41—EDUCATION AND ENTERTAINMENT

FOR EDUCATION SERVICES, NAMELY, DEVELOPING AND PROVIDING WORKSHOPS, CLASSES, AND LECTURES IN THE FIELD OF QUILT MAKING AND DISTRIBUTING PRINTED MATERIAL IN CONNECTION THEREWITH (U.S. CLS. 100, 101 AND 107).

FIRST USE 5-24-2010; IN COMMERCE 5-24-2010.
CARRIE GENOVESE, EXAMINING ATTORNEY

SN 85-450,038. TAKTL, LLC, PITTSBURGH, PA. FILED 10-18-2011.

SITU

THE MARK CONSISTS OF STANDARD CHARACTERS WITHOUT CLAIM TO ANY PARTICULAR FONT, STYLE, SIZE, OR COLOR.

CLASS 11—ENVIRONMENTAL CONTROL APPARATUS

FOR LIGHTING FIXTURES (U.S. CLS. 13, 21, 23, 31 AND 34).

FIRST USE 10-17-2011; IN COMMERCE 10-17-2011.

CLASS 20—FURNITURE AND ARTICLES NOT OTHERWISE CLASSIFIED

FOR FURNITURE PRIMARILY MADE OF ULTRA-HIGH PERFORMANCE CONCRETE (UHPC) (U.S. CLS. 2, 13, 22, 25, 32 AND 50).

FIRST USE 4-0-2010; IN COMMERCE 4-0-2010.
ANDREA K. NADELMAN, EXAMINING ATTORNEY

SN 85-450,096. SOUTHERN SCRIPTS, LLC, NATCHITOCHE, LA. FILED 10-18-2011.



THE MARK CONSISTS OF A MORTAR AND PESTLE OVERLAPPED WITH THE WORDING "SOUTHERN" IN LOWERCASE, STYLIZED FONT AND THE WORD "SCRIPTS" IN ITALICIZED, LOWERCASE STYLIZED FONT. THERE IS NO SPACE BETWEEN THE TWO WORDS.

CLASS 35—ADVERTISING AND BUSINESS

FOR ADMINISTERING PHARMACY REIMBURSEMENT PROGRAMS AND SERVICES; COST MANAGEMENT FOR THE HEALTH BENEFIT PLANS OF OTHERS; COST MANAGEMENT FOR THE HEALTH CARE BENEFIT PLANS OF OTHERS; HEALTH CARE COST CONTAINMENT; HEALTH CARE COST REVIEW; HEALTH CARE UTILIZATION AND REVIEW SERVICES; RETAIL PHARMACY SERVICES (U.S. CLS. 100, 101 AND 102).

FIRST USE 1-1-2011; IN COMMERCE 3-23-2011.

CLASS 36—INSURANCE AND FINANCIAL

FOR PHARMACEUTICAL BENEFIT MANAGEMENT SERVICES; PHARMACY BENEFIT MANAGEMENT SERVICES; PROCESSING, ADMINISTERING AND MANAGING EMPLOYEE BENEFIT PLANS CONCERNING INSURANCE AND FINANCE (U.S. CLS. 100, 101 AND 102).

FIRST USE 1-1-2011; IN COMMERCE 3-23-2011.

CLASS 44—MEDICAL, BEAUTY AND AGRICULTURAL SERVICES

FOR HEALTH CARE SERVICES, NAMELY, DISEASE MANAGEMENT PROGRAMS; HEALTH CARE SERVICES, NAMELY, WELLNESS PROGRAMS; MANAGED HEALTH CARE SERVICES; WELLNESS AND HEALTH-RELATED CONSULTING SERVICES (U.S. CLS. 100 AND 101).

FIRST USE 1-1-2011; IN COMMERCE 3-23-2011.
JORDAN BAKER, EXAMINING ATTORNEY

SN 85-450,099. ENTERTAINMENT PUBLICATIONS, LLC, TROY, MI. FILED 10-18-2011.

SALLYFOSTER.COM

THE MARK CONSISTS OF STANDARD CHARACTERS WITHOUT CLAIM TO ANY PARTICULAR FONT, STYLE, SIZE, OR COLOR.

OWNER OF U.S. REG. NOS. 1,833,830 AND 2,004,108.

THE NAME(S), PORTRAIT(S), AND/OR SIGNATURE(S) SHOWN IN THE MARK IDENTIFIES "SALLY FOSTER", WHOSE CONSENT(S) TO REGISTER IS MADE OF RECORD.

CLASS 16—PAPER GOODS AND PRINTED MATTER

FOR WRAPPING PAPER, PAPER GIFT WRAP, CARDBOARD BOXES, PAPER GIFT BOXES, PAPER GIFT BAGS, GREETING CARDS AND STATIONERY (U.S. CLS. 2, 5, 22, 23, 29, 37, 38 AND 50).

CLASS 35—ADVERTISING AND BUSINESS

FOR RETAIL AND ONLINE RETAIL STORE SERVICES FEATURING WRAPPING PAPER, GIFT WRAP, CARDBOARD BOXES, PAPER GIFT BOXES, PAPER GIFT BAGS, GREETING CARDS, STATIONERY AND RIBBON (U.S. CLS. 100, 101 AND 102).

CLASS 36—INSURANCE AND FINANCIAL

FOR CHARITABLE FUNDRAISING SERVICES EFFECTED BY SELLING MERCHANDISE (U.S. CLS. 100, 101 AND 102).

DORITT L. CARROLL, EXAMINING ATTORNEY

SN 85-450,111. BRANDYWINE PRODUCT GROUP INTERNATIONAL INC., DBA BPG INTERNATIONAL, WILMINGTON, DE. FILED 10-18-2011.

SN 85-450,242. SO SO HAPPY STUDIO, INC., CALABASAS, CA. FILED 10-18-2011.

POSITIVE LIVING

THE MARK CONSISTS OF STANDARD CHARACTERS WITHOUT CLAIM TO ANY PARTICULAR FONT, STYLE, SIZE, OR COLOR.

CLASS 3—COSMETICS AND CLEANING PREPARATIONS

FOR AIR FRAGRANCING PREPARATIONS (U.S. CLS. 1, 4, 6, 50, 51 AND 52).

CLASS 4—LUBRICANTS AND FUELS

FOR CANDLES; SCENTED CANDLES (U.S. CLS. 1, 6 AND 15).
JOHN GARTNER, EXAMINING ATTORNEY

SN 85-450,148. ENTERPRISE HOLDINGS, INC., ST. LOUIS, MO. FILED 10-18-2011.

OUR CAR. YOUR CAR. WECAR.

THE MARK CONSISTS OF STANDARD CHARACTERS WITHOUT CLAIM TO ANY PARTICULAR FONT, STYLE, SIZE, OR COLOR.

OWNER OF U.S. REG. NOS. 3,541,332, 3,716,162 AND OTHERS.

CLASS 35—ADVERTISING AND BUSINESS

FOR PROMOTING PUBLIC AWARENESS OF THE NEED FOR ENVIRONMENTAL CONSERVATION AND ENVIRONMENTAL STEWARDSHIP (U.S. CLS. 100, 101 AND 102).

FIRST USE 1-31-2008; IN COMMERCE 1-31-2008.

CLASS 39—TRANSPORTATION AND STORAGE

FOR VEHICLE RENTAL AND LEASING SERVICES, AND RESERVATION SERVICES FOR THE RENTAL AND LEASING OF VEHICLES (U.S. CLS. 100 AND 105).
FIRST USE 1-31-2008; IN COMMERCE 1-31-2008.
ESTHER A. BORSUK, EXAMINING ATTORNEY

So So Happy

THE MARK CONSISTS OF STANDARD CHARACTERS WITHOUT CLAIM TO ANY PARTICULAR FONT, STYLE, SIZE, OR COLOR.

CLASS 3—COSMETICS AND CLEANING PREPARATIONS

FOR COSMETICS AND MAKE-UP; NAIL POLISH (U.S. CLS. 1, 4, 6, 50, 51 AND 52).

CLASS 9—ELECTRICAL AND SCIENTIFIC APPARATUS

FOR AUDIO SPEAKERS; BLANK USB FLASH DRIVES; DIGITAL AUDIO PLAYERS; DIGITAL CAMERAS; EARPHONES AND HEADPHONES; ELECTRONIC DOCKING STATIONS; FITTED PLASTIC FILMS KNOWN AS SKINS FOR COVERING AND PROTECTING ELECTRONIC APPARATUS, NAMELY, MOBILE PHONES, COMPUTERS, MP3 PLAYERS, AND GAME CONSOLES (U.S. CLS. 21, 23, 26, 36 AND 38).

CLASS 30—STAPLE FOODS

FOR CANDY (U.S. CL. 46).
SALLY SHIH, EXAMINING ATTORNEY

SN 85-450,267. FRITO-LAY NORTH AMERICA, INC., PLANO, TX. FILED 10-18-2011.

UNLEASH THE FUN

THE MARK CONSISTS OF STANDARD CHARACTERS WITHOUT CLAIM TO ANY PARTICULAR FONT, STYLE, SIZE, OR COLOR.

CLASS 29—MEATS AND PROCESSED FOODS

FOR DIPS; POTATO-BASED SNACK FOODS; PROCESSED EDIBLE SEEDS; PROCESSED NUTS (U.S. CL. 46).

CLASS 30—STAPLE FOODS

FOR CORN-BASED SNACK FOODS; FLOUR-BASED CHIPS; MULTIGRAIN-BASED SNACK FOODS; POPPED POPCORN; PRETZELS; SALSA (U.S. CL. 46).
MARLENE BELL, EXAMINING ATTORNEY

SN 85-450,324. EL CAMINO PARTNERS, LLC, MILWAUKEE, WI. FILED 10-18-2011.

SN 85-451,164. NUHABITAT LLC, HOUSTON, TX. FILED 10-19-2011.

LETTERBOX

THE MARK CONSISTS OF STANDARD CHARACTERS WITHOUT CLAIM TO ANY PARTICULAR FONT, STYLE, SIZE, OR COLOR.

CLASS 8—HAND TOOLS

FOR SPOONS (U.S. CLS. 23, 28 AND 44).

CLASS 21—HOUSEWARES AND GLASS

FOR CUPS AND MUGS; TEA BALLS; TEA POTS; TEA STRAINERS (U.S. CLS. 2, 13, 23, 29, 30, 33, 40 AND 50).

CLASS 25—CLOTHING

FOR HATS; SHIRTS (U.S. CLS. 22 AND 39).

CLASS 30—STAPLE FOODS

FOR ICED TEA; TEA; TEA BAGS (U.S. CL. 46).
JESSICA FATHY, EXAMINING ATTORNEY

SN 85-450,349. BRENTWOOD COMMUNICATIONS INTERNATIONAL, INC., AKA BCII, NORTH HILLS, CA. FILED 10-18-2011.

Mullet Mafia

THE MARK CONSISTS OF STANDARD CHARACTERS WITHOUT CLAIM TO ANY PARTICULAR FONT, STYLE, SIZE, OR COLOR.

CLASS 25—CLOTHING

FOR JACKETS; WEARABLE GARMENTS AND CLOTHING, NAMELY, SHIRTS; WOMEN'S CLOTHING, NAMELY, SHIRTS, DRESSES, SKIRTS, BLOUSES (U.S. CLS. 22 AND 39).

CLASS 41—EDUCATION AND ENTERTAINMENT

FOR ENTERTAINMENT SERVICES IN THE NATURE OF AUTOMOBILE RACING AND EXHIBITIONS; ENTERTAINMENT SERVICES IN THE NATURE OF DEVELOPMENT, CREATION, PRODUCTION AND POST-PRODUCTION SERVICES OF MULTIMEDIA ENTERTAINMENT CONTENT; ENTERTAINMENT SERVICES IN THE NATURE OF ON-GOING TELEVISION PROGRAMS IN THE FIELD OF CHILDREN'S ENTERTAINMENT; ENTERTAINMENT SERVICES, NAMELY, A MULTIMEDIA PROGRAM SERIES FEATURING COMEDY, ACTION AND ADVENTURE DISTRIBUTED VIA VARIOUS PLATFORMS ACROSS MULTIPLE FORMS OF TRANSMISSION MEDIA; ENTERTAINMENT SERVICES, NAMELY, AN ON-GOING TELEVISION GAME SHOW AND GAMES OF CHANCE TO BE PLAYED AT A CASINO (U.S. CLS. 100, 101 AND 107).
WILLIAM JACKSON, EXAMINING ATTORNEY

NUHABITAT

THE MARK CONSISTS OF STANDARD CHARACTERS WITHOUT CLAIM TO ANY PARTICULAR FONT, STYLE, SIZE, OR COLOR.

CLASS 35—ADVERTISING AND BUSINESS

FOR REAL ESTATE MARKETING SERVICES, NAMELY, ON-LINE MARKETING SERVICES RELATED TO REAL ESTATE (U.S. CLS. 100, 101 AND 102).
FIRST USE 6-1-2011; IN COMMERCE 6-1-2011.

CLASS 36—INSURANCE AND FINANCIAL

FOR REAL ESTATE BROKERAGE (U.S. CLS. 100, 101 AND 102).
FIRST USE 6-1-2011; IN COMMERCE 6-1-2011.
MICHAEL ENGEL, EXAMINING ATTORNEY

SN 85-451,175. NUGEN TECHNOLOGIES, INC., SAN CARLOS, CA. FILED 10-19-2011.

MONDRIAN

THE MARK CONSISTS OF STANDARD CHARACTERS WITHOUT CLAIM TO ANY PARTICULAR FONT, STYLE, SIZE, OR COLOR.

CLASS 1—CHEMICALS

FOR CHEMICALS, ASSAYS, REAGENTS AND KITS CONSISTING PRIMARILY OF CHEMICALS, ASSAYS, AND REAGENTS FOR THE ANALYSIS OF NUCLEIC ACIDS, PROTEINS, AND ANTIBODIES FOR SCIENTIFIC AND RESEARCH USE; CHEMICALS, ASSAYS, REAGENTS AND KITS CONSISTING PRIMARILY OF CHEMICALS, ASSAYS, AND REAGENTS FOR NUCLEIC ACID SEQUENCE AMPLIFICATION, SEQUENCE ANALYSIS AND OLIGONUCLEOTIDES, CDNA AND RNA LIBRARIES AND MICROARRAYS FOR SCIENTIFIC AND RESEARCH USE (U.S. CLS. 1, 5, 6, 10, 26 AND 46).

CLASS 9—ELECTRICAL AND SCIENTIFIC APPARATUS

FOR LABORATORY EQUIPMENT IN THE NATURE OF SCIENTIFIC INSTRUMENTS AND APPARATUS, NAMELY, MICROFLUIDIC CARTRIDGES FOR SCIENTIFIC AND RESEARCH USE; LABORATORY EQUIPMENT, NAMELY, DIGITAL MICROFLUIDIC INSTRUMENTS FOR NUCLEIC ACID SAMPLE PREPARATION; LABORATORY EQUIPMENT, NAMELY, DIGITAL MICROFLUIDIC INSTRUMENTS FOR GENOMIC ANALYSIS (U.S. CLS. 21, 23, 26, 36 AND 38).
CAROLYN CATALDO, EXAMINING ATTORNEY

SN 85-452,204. BLANCO GMBH + CO KG, 75038 OBERDERDINGEN, FED REP GERMANY, FILED 10-20-2011.

CERANA

THE MARK CONSISTS OF STANDARD CHARACTERS WITHOUT CLAIM TO ANY PARTICULAR FONT, STYLE, SIZE, OR COLOR.

CLASS 11—ENVIRONMENTAL CONTROL APPARATUS

FOR SINKS; SINKS HAVING A DRAINING AREA; SINKS WITHOUT A DRAINING AREA; SINK BASINS; UNDERMOUNT SINK BOWLS; PARTS OF AND FITTINGS FOR THE AFORESAID GOODS (U.S. CLS. 13, 21, 23, 31 AND 34).

CLASS 21—HOUSEWARES AND GLASS

FOR PREPARATION BOWLS; WASTE BASKETS FOR KITCHEN SINKS; CHOPPING BOARDS FOR KITCHEN USE; SINK ACCESSORIES, NAMELY, CUTTING BOARDS, COLANDERS AND DISH DRYING RACKS; PARTS OF FITTINGS FOR THE AFORESAID GOODS (U.S. CLS. 2, 13, 23, 29, 30, 33, 40 AND 50).
WILLIAM ROSSMAN, EXAMINING ATTORNEY

SN 85-452,458. GFA BRANDS, INC., PARAMUS, NJ. FILED 10-20-2011.

GREAT TASTE FROM THE
LEADING EDGE OF GOOD HEALTH

THE MARK CONSISTS OF STANDARD CHARACTERS WITHOUT CLAIM TO ANY PARTICULAR FONT, STYLE, SIZE, OR COLOR.

OWNER OF U.S. REG. NO. 3,881,694.

CLASS 5—PHARMACEUTICALS

FOR MEAL REPLACEMENT BARS; MEAL REPLACEMENT DRINKS; NUTRITIONAL SUPPLEMENTS; VITAMIN FORTIFIED BEVERAGES; VITAMINS (U.S. CLS. 6, 18, 44, 46, 51 AND 52).

CLASS 25—CLOTHING

FOR FOOTWEAR; HEADWEAR; JACKETS; PANTS; SHIRTS (U.S. CLS. 22 AND 39).

CLASS 28—TOYS AND SPORTING GOODS

FOR MANUALLY-OPERATED EXERCISE EQUIPMENT (U.S. CLS. 22, 23, 38 AND 50).

CLASS 29—MEATS AND PROCESSED FOODS

FOR BUTTER; BUTTER SUBSTITUTES; CHEESE; EDIBLE OILS; EGGS; MILK; NUT AND SEED-BASED SNACK BARS; NUT BUTTERS; SHORTENING; SNACK MIX CONSISTING PRIMARILY OF PROCESSED FRUITS, PROCESSED NUTS AND/OR RAISINS; SOUR CREAM; VEGETABLE CHIPS; YOGURT; FROZEN ENTREES CONSISTING PRIMARILY OF MEAT, FISH, POULTRY OR VEGETABLES (U.S. CL. 46).

CLASS 30—STAPLE FOODS

FOR BAKERY GOODS; BREAKFAST CEREALS; CAKE MIXES; COFFEE; CRACKERS; FROSTINGS; FROZEN YOGURT; GRAIN-BASED SNACK FOODS; GRANOLA-BASED SNACK BARS; HOT CHOCOLATE; ICE-CREAM; MAYONNAISE; PITA CHIPS; POPCORN; PRETZELS; READY-TO-EAT CEREALS; SALAD DRESSING; SNACK MIX CONSISTING PRIMARILY OF CRACKERS, PRETZELS AND/OR POPPED POPCORN; SPICES; TEA; FROZEN ENTREES CONSISTING PRIMARILY OF PASTA OR RICE (U.S. CL. 46).

CLASS 31—NATURAL AGRICULTURAL PRODUCTS

FOR RAW POPCORN (U.S. CLS. 1 AND 46).

CLASS 32—LIGHT BEVERAGES

FOR ENERGY DRINKS; FRUIT JUICE (U.S. CLS. 45, 46 AND 48).
REBECCA SMITH, EXAMINING ATTORNEY

SN 85-452,532. J. E. DUNN CONSTRUCTION COMPANY, KANSAS CITY, MO. FILED 10-20-2011.

INNOVATIONS 10.01

THE MARK CONSISTS OF STANDARD CHARACTERS WITHOUT CLAIM TO ANY PARTICULAR FONT, STYLE, SIZE, OR COLOR.

CLASS 35—ADVERTISING AND BUSINESS

FOR BUSINESS MANAGEMENT SERVICES (U.S. CLS. 100, 101 AND 102).

CLASS 42—SCIENTIFIC AND COMPUTER SERVICES

FOR APPLICATION SERVICE PROVIDER, NAMELY, HOSTING AND MANAGING COMPUTER SOFTWARE OF OTHERS FOR DOCUMENTING THE BUILDING PROCESS AND FACILITIES MANAGEMENT; APPLICATION SERVICE PROVIDER, NAMELY, HOSTING AND MANAGING COMPUTER SOFTWARE OF OTHERS FOR USE IN MANAGING A FACILITY'S CONTENTS, EQUIPMENT, FURNITURE, AND INFRASTRUCTURE; APPLICATION SERVICE PROVIDER, NAMELY, HOSTING AND MANAGING COMPUTER SOFTWARE OF OTHERS FOR MOBILE PHONES, PORTABLE MEDIA PLAYERS, AND HANDHELD COMPUTERS; APPLICATION SERVICE PROVIDER, NAMELY, HOSTING AND MANAGING COMPUTER SOFTWARE OF OTHERS FOR DOCUMENTING THE BUILDING PROCESS AND TO MANAGE A FACILITY'S CONTENTS, EQUIPMENT, FURNITURE, AND INFRASTRUCTURE (U.S. CLS. 100 AND 101).

SALLY SHIH, EXAMINING ATTORNEY

SN 85-452,535. J. E. DUNN CONSTRUCTION COMPANY,
KANSAS CITY, MO. FILED 10-20-2011.

Innovations 10.01

THE MARK CONSISTS OF "INNOVATIONS 10.01" IN A STYLIZED FORMAT. AN INVISIBLE HORIZONTAL LINE GOES THROUGH THE MIDDLE OF "10.01". BELOW THE MARK IS A HORIZONTAL LINE WHICH INCREASES IN HEIGHT FROM BEGINNING TO END OF THE MARK.

CLASS 35—ADVERTISING AND BUSINESS

FOR BUSINESS MANAGEMENT SERVICES (U.S. CLS. 100, 101 AND 102).

CLASS 42—SCIENTIFIC AND COMPUTER SERVICES

FOR APPLICATION SERVICE PROVIDER, NAMELY, HOSTING AND MANAGING COMPUTER SOFTWARE OF OTHERS FOR DOCUMENTING THE BUILDING PROCESS AND FACILITIES MANAGEMENT; APPLICATION SERVICE PROVIDER, NAMELY, HOSTING AND MANAGING COMPUTER SOFTWARE OF OTHERS FOR USE IN MANAGING A FACILITY'S CONTENTS, EQUIPMENT, FURNITURE, AND INFRASTRUCTURE; APPLICATION SERVICE PROVIDER, NAMELY, HOSTING AND MANAGING COMPUTER SOFTWARE OF OTHERS FOR MOBILE PHONES, PORTABLE MEDIA PLAYERS, AND HANDHELD COMPUTERS; APPLICATION SERVICE PROVIDER, NAMELY, HOSTING AND MANAGING COMPUTER SOFTWARE OF OTHERS FOR DOCUMENTING THE BUILDING PROCESS AND TO MANAGE A FACILITY'S CONTENTS, EQUIPMENT, FURNITURE, AND INFRASTRUCTURE (U.S. CLS. 100 AND 101).

SALLY SHIH, EXAMINING ATTORNEY

SN 85-452,965. BREWER QUILTING AND SEWING SUPPLIES, LLC, AURORA, IL. FILED 10-21-2011.

SEW LOGIC

THE MARK CONSISTS OF STANDARD CHARACTERS WITHOUT CLAIM TO ANY PARTICULAR FONT, STYLE, SIZE, OR COLOR.

NO CLAIM IS MADE TO THE EXCLUSIVE RIGHT TO USE "SEW", APART FROM THE MARK AS SHOWN.

CLASS 7—MACHINERY

FOR STRUCTURAL PARTS AND ACCESSORIES FOR SEWING AND EMBROIDERY MACHINES (U.S. CLS. 13, 19, 21, 23, 31, 34 AND 35).

CLASS 8—HAND TOOLS

FOR SEWING SCISSORS, EMBROIDERY SCISSORS (U.S. CLS. 23, 28 AND 44).

CLASS 20—FURNITURE AND ARTICLES NOT OTHERWISE CLASSIFIED

FOR EMBROIDERY FRAMES (U.S. CLS. 2, 13, 22, 25, 32 AND 50).

CLASS 23—YARNS AND THREADS

FOR THREAD, YARN, EMBROIDERY THREAD AND FLOSS (U.S. CL. 43).

CLASS 26—FANCY GOODS

FOR SEWING KITS COMPRISED OF NEEDLES, THIMBLES, SCISSORS AND THREAD, SOLD AS A UNIT; SEWING BASKETS, SEWING BOXES (U.S. CLS. 37, 39, 40, 42 AND 50).

JAMES LOVELACE, EXAMINING ATTORNEY

SN 85-453,138. BREWER QUILTING AND SEWING SUPPLIES, LLC, AURORA, IL. FILED 10-21-2011.



NO CLAIM IS MADE TO THE EXCLUSIVE RIGHT TO USE "SEW", APART FROM THE MARK AS SHOWN.

THE MARK CONSISTS OF A GLOBE WITH MERIDIANS AND PARALLELS ONLY. THE WORDS "SEW LOGIC" APPEAR HORIZONTALLY, IN A SCRIPT FONT, THE WORD "SEW" BEING A DARKER SHADE THAN THE WORD "LOGIC". THE LETTERS "S" AND "E" APPEAR TO THE LEFT OF THE GLOBE, THE LETTERS "W", "L" AND "O" ARE SUPERIMPOSED OVER THE GLOBE, AND THE LETTERS "G", "I" AND "C" APPEAR TO THE RIGHT OF THE GLOBE. A BAR EXTENDS FROM THE TOP OF THE GLOBE, THE BAR NARROWING FROM THE TOP DOWNWARD. A SECOND BAR EXTENDS FROM THE BOTTOM OF THE GLOBE, THE BAR NARROWING FROM THE TOP DOWNWARD.

CLASS 7—MACHINERY

FOR STRUCTURAL PARTS AND ACCESSORIES FOR SEWING AND EMBROIDERY MACHINES (U.S. CLS. 13, 19, 21, 23, 31, 34 AND 35).

CLASS 8—HAND TOOLS

FOR SEWING SCISSORS, EMBROIDERY SCISSORS (U.S. CLS. 23, 28 AND 44).

CLASS 20—FURNITURE AND ARTICLES NOT OTHERWISE CLASSIFIED

FOR EMBROIDERY FRAMES (U.S. CLS. 2, 13, 22, 25, 32 AND 50).

CLASS 23—YARNS AND THREADS

FOR THREAD, YARN, EMBROIDERY THREAD AND FLOSS (U.S. CL. 43).

CLASS 26—FANCY GOODS

FOR SEWING BOXES, SEWING BASKETS, SEWING KITS COMPRISED OF NEEDLES, THIMBLES, SCISSORS AND THREAD, SOLD AS A UNIT (U.S. CLS. 37, 39, 40, 42 AND 50).

JAMES LOVELACE, EXAMINING ATTORNEY

SN 85-453,183. ENTREMONT, PASCAL J., ANTWERPEN, BELGIUM, FILED 10-21-2011.

SI (Significative Inclusion)

THE MARK CONSISTS OF STANDARD CHARACTERS WITHOUT CLAIM TO ANY PARTICULAR FONT, STYLE, SIZE, OR COLOR.

CLASS 14—JEWELRY

FOR PRECIOUS STONES (U.S. CLS. 2, 27, 28 AND 50).

CLASS 40—MATERIAL TREATMENT

FOR TREATMENT OF MATERIALS, NAMELY, TREATMENT OF GEMSTONES BY LASER BEAM (U.S. CLS. 100, 103 AND 106).

CLASS 41—EDUCATION AND ENTERTAINMENT

FOR EDUCATION AND TRAINING SERVICES, NAMELY, PROVIDING CLASSES, SEMINARS, WORKSHOPS IN THE FIELD OF GEMOLOGY (U.S. CLS. 100, 101 AND 107).

CLASS 42—SCIENTIFIC AND COMPUTER SERVICES

FOR SCIENTIFIC AND TECHNOLOGICAL SERVICES, NAMELY, RESEARCH AND DEVELOPMENT IN THE FIELD OF GEMOLOGY; INDUSTRIAL ANALYSIS AND RESEARCH SERVICES IN THE FIELD OF GEMOLOGY; DESIGN AND DEVELOPMENT OF COMPUTER HARDWARE AND SOFTWARE IN THE FIELD OF GEMOLOGY (U.S. CLS. 100 AND 101).

MICHAEL WEBSTER, EXAMINING ATTORNEY

SN 85-454,143. RETIREMENT INCOME INDUSTRY ASSOCIATION, BOSTON, MA. FILED 10-24-2011.



OWNER OF U.S. REG. NO. 3,409,173.
NO CLAIM IS MADE TO THE EXCLUSIVE RIGHT TO USE "RETIREMENT INCOME INDUSTRY ASSOCIATION", APART FROM THE MARK AS SHOWN.
THE COLOR(S) NAVY BLUE AND BURNT SIENNA IS/ ARE CLAIMED AS A FEATURE OF THE MARK.

THE MARK CONSISTS OF AN OPEN SWIRL ACROSS THE STYLIZED LETTERS "RIIA" IN NAVY BLUE BENEATH A NAVY BLUE HORIZONTAL BAND AND THE WORDS "RETIREMENT INCOME" IN BURNT SIENNA UPPER CASE LETTERS AND ABOVE THE WORDS "INDUSTRY ASSOCIATION" IN BURNT SIENNA UPPER CASE LETTERS AND A NAVY BLUE HORIZONTAL BAND.

CLASS 16—PAPER GOODS AND PRINTED MATTER

FOR EDUCATION AND LEARNING PUBLICATIONS, NAMELY, BOOKS, BOOKLETS, WORKBOOKS, HAND-OUTS AND COURSE MATERIALS IN THE FIELD OF RETIREMENT INCOME EDUCATION, PLANNING, MANAGEMENT AND POLICY FORMULATION (U.S. CLS. 2, 5, 22, 23, 29, 37, 38 AND 50).

FIRST USE 12-31-2006; IN COMMERCE 12-31-2006.

CLASS 41—EDUCATION AND ENTERTAINMENT

FOR EDUCATION SERVICES, NAMELY, PROVIDING SEMINARS, NON-DOWNLOADABLE WEBINARS, CONFERENCES AND CLASSES IN THE FIELD OF RETIREMENT INCOME PLANNING MANAGEMENT TO FINANCIAL PROFESSIONALS AND PROVIDING AN IN-PERSON EDUCATIONAL FORUM FOR FINANCIAL PROFESSIONALS OF DIVERSE DISCIPLINES ACROSS THE FINANCIAL INDUSTRY TO COLLABORATE ABOUT RETIREMENT INCOME AND POLICY ISSUES (U.S. CLS. 100, 101 AND 107).

FIRST USE 12-31-2006; IN COMMERCE 12-31-2006.

KATHERINE E. HALMEN, EXAMINING ATTORNEY

SN 85-455,471. HARSCO TECHNOLOGIES LLC, FAIRMONT, MN. FILED 10-25-2011.



OWNER OF U.S. REG. NO. 3,623,833.

CLASS 3—COSMETICS AND CLEANING PREPARATIONS

FOR SLAG PRODUCTS, NAMELY, ABRASIVES IN THE FORM OF BLAST GRIT AND FRICTION GRANULES FOR USE IN FINISHING, CLEANING AND ABRADING SURFACES OF ALL KINDS (U.S. CLS. 1, 4, 6, 50, 51 AND 52).

FIRST USE 1-30-2008; IN COMMERCE 1-30-2008.

CLASS 19—NON-METALLIC BUILDING MATERIALS

FOR NON-METAL ROOFING GRANULES FOR THE MANUFACTURE OF SHINGLES, SHEETING AND OTHER ROOFING SURFACES (U.S. CLS. 1, 12, 33 AND 50).

FIRST USE 1-30-2008; IN COMMERCE 1-30-2008.
JENNIFER MARTIN, EXAMINING ATTORNEY

SN 85-455,494. HARSCO TECHNOLOGIES LLC, FAIRMONT, MN. FILED 10-25-2011.

SN 85-455,914. BRISAS DEL CARIBE, CORP., BAYAMON, PUERTO RICO, FILED 10-25-2011.



OWNER OF U.S. REG. NO. 3,623,833.
THE MARK CONSISTS OF SILHOUETTE OF A HORSE HEAD ABOVE THE WORDS "IRON HORSE".

CLASS 3—COSMETICS AND CLEANING PREPARATIONS

FOR SLAG PRODUCTS, NAMELY, ABRASIVES IN THE FORM OF BLAST GRIT AND FRICTION GRANULES FOR USE IN FINISHING, CLEANING AND ABRADING SURFACES OF ALL KINDS (U.S. CLS. 1, 4, 6, 50, 51 AND 52).

CLASS 19—NON-METALLIC BUILDING MATERIALS

FOR NON-METAL ROOFING GRANULES COMPRISED PRIMARILY OF COPPER SLAG FOR THE MANUFACTURE OF SHINGLES, SHEETING AND OTHER ROOFING SURFACES (U.S. CLS. 1, 12, 33 AND 50).

JENNIFER MARTIN, EXAMINING ATTORNEY

SN 85-455,674. SEE, INC., SOUTHFIELD, MI. FILED 10-25-2011.

Protect your privates.



THE MARK CONSISTS OF THE WORDS "PROTECT YOUR PRIVATES." ABOVE THREE HEARTS WITH THE TWO SMALLER HEARTS CONNECTED TO THE CENTERED LARGE HEART.

CLASS 35—ADVERTISING AND BUSINESS

FOR CHARITABLE SERVICES, NAMELY, PROMOTING THE PUBLIC INTEREST AND AWARENESS IN CANCER RESEARCH AND EDUCATION (U.S. CLS. 100, 101 AND 102).

FIRST USE 9-1-2011; IN COMMERCE 9-1-2011.

CLASS 36—INSURANCE AND FINANCIAL

FOR CHARITABLE FUNDRAISING SERVICES, AND CHARITABLE FUNDRAISING AND FINANCING RESEARCH RELATING TO OVARIAN CANCER (U.S. CLS. 100, 101 AND 102).

FIRST USE 9-1-2011; IN COMMERCE 9-1-2011.
KELLY CHOE, EXAMINING ATTORNEY



NO CLAIM IS MADE TO THE EXCLUSIVE RIGHT TO USE "PET" AND "PET CARE", APART FROM THE MARK AS SHOWN.

THE MARK CONSISTS OF A REPRESENTATION OF TWO ANIMAL PAWS WITH THE WORDS "HAPPY PET" ABOVE THE WORDS "CONTROL PET CARE".

CLASS 3—COSMETICS AND CLEANING PREPARATIONS

FOR COTTON BUDS FOR COSMETIC PURPOSES; DISPOSABLE WIPES IMPREGNATED WITH CLEANSING COMPOUNDS FOR USE ON PETS' EYES AND EARS; IMPREGNATED CLEANING PADS IMPREGNATED WITH TOILET PREPARATIONS; NON-MEDICATED GROOMING PREPARATIONS FOR PETS, NAMELY, SHAMPOO, CONDITIONERS; ODOR REMOVERS FOR PETS; PET FRAGRANCES; PET SHAMPOO; PET SHAMPOO AND CONDITIONER (U.S. CLS. 1, 4, 6, 50, 51 AND 52).

FIRST USE 12-16-2004; IN COMMERCE 12-16-2004.

CLASS 5—PHARMACEUTICALS

FOR MEDICATED GROOMING PREPARATIONS FOR PETS, NAMELY, SHAMPOO, CONDITIONERS (U.S. CLS. 6, 18, 44, 46, 51 AND 52).

FIRST USE 12-16-2004; IN COMMERCE 12-16-2004.

CLASS 18—LEATHER GOODS

FOR COLLARS FOR PETS; COLLARS FOR PETS BEARING MEDICAL INFORMATION; DISPOSABLE PET DIAPERS; PET CLOTHING; PET PRODUCTS, NAMELY, PET RESTRAINING DEVICES CONSISTING OF LEASHES, COLLARS, HARNESSES, RESTRAINING STRAPS, AND LEASHES WITH LOCKING DEVICES; PET RESTRAINING DEVICES CONSISTING OF HARNESSES AND/OR RESTRAINING STRAPS, FOR USE IN PET GROOMING OR VETERINARY CARE; PET RESTRAINING DEVICES CONSISTING OF COLLARS, HARNESSES, RESTRAINING STRAPS, LEASHES FOR USE IN PET GROOMING OR VETERINARY CARE (U.S. CLS. 1, 2, 3, 22 AND 41).

FIRST USE 12-16-2004; IN COMMERCE 12-16-2004.

CLASS 20—FURNITURE AND ARTICLES NOT OTHERWISE CLASSIFIED

FOR PORTABLE BEDS FOR PETS (U.S. CLS. 2, 13, 22, 25, 32 AND 50).

FIRST USE 12-16-2004; IN COMMERCE 12-16-2004.

CLASS 21—HOUSEWARES AND GLASS

FOR CAGES FOR PETS; GROOMING TOOLS FOR PETS, NAMELY, COMBS AND BRUSHES; PET FEEDING AND DRINKING BOWLS (U.S. CLS. 2, 13, 23, 29, 30, 33, 40 AND 50).

FIRST USE 12-16-2004; IN COMMERCE 12-16-2004.

CLASS 28—TOYS AND SPORTING GOODS

FOR PET TOYS (U.S. CLS. 22, 23, 38 AND 50).
FIRST USE 12-16-2004; IN COMMERCE 12-16-2004.

SN 85-456,981. HERMES INTERNATIONAL, 75008 PARIS, FRANCE, FILED 10-26-2011.

CLASS 31—NATURAL AGRICULTURAL PRODUCTS

FOR ANIMAL LITTER; CAT LITTER; SANDED PAPER FOR PETS (U.S. CLS. 1 AND 46).
FIRST USE 12-16-2004; IN COMMERCE 12-16-2004.
TINA MAI, EXAMINING ATTORNEY



SN 85-456,382. AQUION, INC., ELK GROVE VILLAGE, IL.
FILED 10-26-2011.

PRIORITY CLAIMED UNDER SEC. 44(D) ON FRANCE APPLICATION NO. 113828625, FILED 5-4-2011, REG. NO. 113828625, DATED 5-4-2011, EXPIRES 5-4-2021.

OWNER OF U.S. REG. NOS. 3,233,557, 3,561,331 AND OTHERS.

THE MARK CONSISTS OF A MISCELLANEOUS DIAMOND DESIGN WITH THE LETTER "H" IN THE CENTER.

PROSYSTEMS

THE MARK CONSISTS OF STANDARD CHARACTERS WITHOUT CLAIM TO ANY PARTICULAR FONT, STYLE, SIZE, OR COLOR.

OWNER OF U.S. REG. NO. 3,081,521.

CLASS 11—ENVIRONMENTAL CONTROL APPARATUS

FOR WATER TREATMENT AND WATER CONDITIONING SYSTEMS COMPOSED PRIMARILY OF WATER FILTRATION UNITS AND WATER CONDITIONING UNITS FOR DOMESTIC, COMMERCIAL, AND INDUSTRIAL USE (U.S. CLS. 13, 21, 23, 31 AND 34).
FIRST USE 7-5-2002; IN COMMERCE 7-5-2002.

CLASS 18—LEATHER GOODS

FOR GOODS MADE OF LEATHER AND IMITATIONS OF LEATHER, NAMELY, HANDBAGS, TRAVELLING BAGS, RUCKSACKS, SCHOOL SATCHELS AND SCHOOL BAGS, BEACH BAGS, SHOPPING BAGS MADE OF CANVAS, LEATHER AND TEXTILE, GARMENT TRAVEL BAGS, SPORT BAGS, WHEELED SHOPPING BAGS, LEATHER SACKS AND POUCHES; POCKET WALLETS, PURSES, CREDIT CARD CASES, BUSINESS CARD CASES, ATTACHÉ CASES, BRIEFCASES, LEATHER KEY CASES, TRUNKS, SUITCASES, TOILETRY BAGS SOLD EMPTY, HANDBAGS FOR EVENING, MINAUDIERES IN THE NATURE OF SMALL CLUTCH PURSES (U.S. CLS. 1, 2, 3, 22 AND 41).

CLASS 25—CLOTHING

FOR CLOTHING FOR MEN, WOMEN AND CHILDREN, NAMELY, T-SHIRTS, SWEATSHIRTS, SHORTS, TANK TOPS, SWEATERS, SHIRTS, PANTS, DRESSES, SWIMWEAR, RAINCOATS, PARKAS, PONCHOS, SLEEPWEAR, UNDERWEAR, ROBES, APRONS, HEADBANDS, PAREOS, DRESSING GOWNS, BATHROBES, HOSIERY, SASHES, SHOES AND INFANT SLEEPERS, BOOTS, HATS, CAPS, BONNETS, GLOVES, MITTENS, TIES, BELTS, SCARVES, STOCKINGS, SOCKS, TIGHTS AND SUSPENDERS (U.S. CLS. 22 AND 39).

BRIAN CALLAGHAN, EXAMINING ATTORNEY

CLASS 37—CONSTRUCTION AND REPAIR

FOR TECHNICAL CONSULTING SERVICES, NAMELY, TECHNICAL ADVICE RELATED TO THE INSTALLATION, MAINTENANCE AND RELATED OPERATION OF WATER TREATMENT AND CONDITIONING EQUIPMENT (U.S. CLS. 100, 103 AND 106).
FIRST USE 1-1-2009; IN COMMERCE 1-1-2009.

SN 85-457,026. WJB GROUP, DBA WJB BEARINGS INC., CITY OF INDUSTRY, CA. FILED 10-26-2011.

CLASS 41—EDUCATION AND ENTERTAINMENT

FOR EDUCATIONAL SERVICES, NAMELY, TRAINING IN THE USE, IMPORTANCE, INSTALLATION, MAINTENANCE AND RELATED OPERATION OF WATER TREATMENT AND CONDITIONING EQUIPMENT (U.S. CLS. 100, 101 AND 107).
FIRST USE 5-1-2009; IN COMMERCE 5-1-2009.
TRICIA SONNEBORN, EXAMINING ATTORNEY

ZWZ

THE MARK CONSISTS OF STANDARD CHARACTERS WITHOUT CLAIM TO ANY PARTICULAR FONT, STYLE, SIZE, OR COLOR.

CLASS 6—METAL GOODS

FOR METAL COMPONENTS FOR METAL PROTECTIVE AND SECURITY WINDOW SHUTTERS, NAMELY, SLATS, SHUTTERBOXES, SIDE FRAMES, END CAPS, CRANK HANDLES, PULL STRAPS, SIDE TRACKS, BALL BEARINGS AND INSTALLATION HARDWARE, NAMELY, ROLLERS, RAILS, CABLES, CARRIERS, PINS, LOCKS, CLIPS, BRACKETS AND SCREWS (U.S. CLS. 2, 12, 13, 14, 23, 25 AND 50).

FIRST USE 1-1-1995; IN COMMERCE 1-1-1995.

CLASS 7—MACHINERY

FOR BALL BEARINGS FOR USE IN MACHINES, NAMELY, COMPUTER NUMERICAL CONTROL MILLING MACHINES; BALL RINGS FOR BEARINGS FOR MACHINES, NAMELY, COMPUTER NUMERICAL CONTROL MILLING MACHINES; BEARING BRACKETS FOR MACHINES; BEARINGS FOR TRANSMISSION SHAFTS, BEING PARTS OF MACHINES; BEARINGS, AS PARTS OF MACHINES; ENGINE BEARINGS; MACHINE PARTS, NAMELY, BEARING HOUSINGS; MACHINE PARTS, NAMELY, BEARING INSERTS; MACHINE PARTS, NAMELY, BEARINGS; MACHINE PARTS, NAMELY, BEARINGS AND BUSHINGS; MACHINE PARTS, NAMELY, ROLL MILL BEARINGS; MACHINE PARTS, NAMELY, ROLLER BEARINGS; ROLLER BEARINGS FOR MACHINES; SELF-LUBRICATING MECHANICAL FRICTION PARTS, ESPECIALLY OF COMPOSITE MATERIALS, NAMELY, WEAR RINGS, WASHERS, BUSHINGS, SPHERICAL BEARINGS, BEARING PADS, SLIDING BLOCKS AND MACHINE TRANSMISSION GEARS ALL FOR LOAD BEARING MACHINES, CONVEYORS, HANDLING TRUCKS AND MACHINES, LIFTING MACHINES, AGRICULTURAL MACHINERY, CONSTRUCTION EQUIPMENT MACHINES AND HYDRAULIC TURBINES; SHAFT BEARINGS FOR VACUUM PUMPS (U.S. CLS. 13, 19, 21, 23, 31, 34 AND 35).

FIRST USE 1-1-1995; IN COMMERCE 1-1-1995.

CLASS 12—VEHICLES

FOR PARTS OF MOTORCYCLES, NAMELY, FORK BEARINGS AND RACES; WHEEL BEARING KITS FOR USE WITH LAND VEHICLES; WHEEL BEARINGS FOR LAND VEHICLES (U.S. CLS. 19, 21, 23, 31, 35 AND 44).

FIRST USE 1-1-1995; IN COMMERCE 1-1-1995.
WILLIAM JACKSON, EXAMINING ATTORNEY

SN 85-457,101. EXPLORA, INC., MIAMI, FL. FILED 10-26-2011.



NO CLAIM IS MADE TO THE EXCLUSIVE RIGHT TO USE "BEST QUALITY", APART FROM THE MARK AS SHOWN.

THE COLOR(S) BLACK, WHITE, YELLOW, GREEN, BLUE, GREY IS/ARE CLAIMED AS A FEATURE OF THE MARK.

THE MARK CONSISTS OF A CIRCLE OUTLINED IN GREEN WITH THE WORD "EXPLORA" IN BLACK LET-

TERS AND TWO INNER CIRCLES IN YELLOW AND OUTLINED IN BLACK. WITHIN THE INNER CIRCLE IS A PATCH OF GREEN AND A CARICATURE OF A MAN WEARING A HAT, DRESSED IN WHITE AND OUTLINED IN BLACK. HE IS HOLDING BINOCULARS UP TO HIS EYES. THE BINOCULARS ARE OUTLINED IN BLACK AND DEPICT A GLOBE OF THE WORLD WITH BLUE AND GREEN COLORS FOR EACH LENS. THE WORDS "BEST QUALITY" ARE IN GREY ON THE BOTTOM PART OF THE CIRCLE, ALONG WITH THE WORD "POSTAGE" CIRCLED AND A WAVY-LINED POSTAGE STAMP UNDERNEATH ALL IN GREY.

CLASS 29—MEATS AND PROCESSED FOODS

FOR SEAFOOD (U.S. CL. 46).

CLASS 31—NATURAL AGRICULTURAL PRODUCTS

FOR FRESH FRUIT AND VEGETABLES (U.S. CLS. 1 AND 46).

WILLIAM VERHOSEK, EXAMINING ATTORNEY

SN 85-457,422. MASTERCARD INTERNATIONAL INCORPORATED, PURCHASE, NY. FILED 10-27-2011.

**INTELLIGENCE TO ENABLE
DECISIONS AT THE SPEED OF
CONSUMER BEHAVIOR**

THE MARK CONSISTS OF STANDARD CHARACTERS WITHOUT CLAIM TO ANY PARTICULAR FONT, STYLE, SIZE, OR COLOR.

CLASS 35—ADVERTISING AND BUSINESS

FOR BUSINESS INFORMATION SERVICES IN THE FIELD OF DATA ANALYTICS, NAMELY, DATA SELECTION, DATA ARRANGEMENT, DATA PROCESSING, DATA PRESENTATION, DATA CLEANSING AND DATA DISTRIBUTION IN THE FIELDS OF MARKETING DEMOGRAPHICS AND CONSUMER PURCHASING BEHAVIORS; BUSINESS MANAGEMENT OF CONSUMER, MARKETING, DEMOGRAPHIC AND PAYMENTS INFORMATION AND DATA OF OTHERS; BUSINESS DATA AND INFORMATION PROCESSING SERVICES, NAMELY, DATA SELECTION, DATA ARRANGEMENT, DATA PROCESSING, DATA ANALYTICS, DATA CLEANSING TO REMOVE ERRONEOUS OR UNWANTED INFORMATION RELATING THERETO, DATA MERGING, DATA PRESENTATION, AND DATA DISTRIBUTION SERVICES; PROVIDING BUSINESS INFORMATION AND REPORTS; BUSINESS ANALYSIS AND EVALUATION OF CONSUMER, MARKETING AND DEMOGRAPHIC INFORMATION; BUSINESS ANALYSIS OF CONSUMER, MARKETING, DEMOGRAPHIC AND PAYMENTS INFORMATION; BUSINESS MARKETING CONSULTATION SERVICES; MARKET RESEARCH; CONDUCTING MARKETING STUDIES; BUSINESS INFORMATION SERVICES, NAMELY, PROVIDING MARKETING INFORMATION RELATING TO THE FIELDS OF BANKING AND FINANCIAL SERVICES; PROVIDING MARKETING RESEARCH, BUSINESS RESEARCH, AND MARKET RESEARCH CONSULTING SERVICES, ALL RELATED TO THE FIELDS OF BANKING AND FINANCIAL SERVICES; PROVIDING BUSINESS STATISTICAL INFORMATION; BUSINESS MARKETING CONSULTING SERVICES IN REGARDS TO CONSUMER PURCHASING BEHAVIORS (U.S. CLS. 100, 101 AND 102).

CLASS 36—INSURANCE AND FINANCIAL

FOR FINANCIAL SERVICES, NAMELY, PROVIDING ADVISORY SERVICES IN THE FIELD OF BANKING, CREDIT AND DEBIT CARDS AND FINANCE (U.S. CLS. 100, 101 AND 102).

DAVID MURRAY, EXAMINING ATTORNEY

SN 85-457,424. MASTERCARD INTERNATIONAL INCORPORATED, PURCHASE, NY. FILED 10-27-2011.

DECISION INTELLIGENCE

THE MARK CONSISTS OF STANDARD CHARACTERS WITHOUT CLAIM TO ANY PARTICULAR FONT, STYLE, SIZE, OR COLOR.

OWNER OF U.S. REG. NO. 3,477,234.

SN 85-457,423. MASTERCARD INTERNATIONAL INCORPORATED, PURCHASE, NY. FILED 10-27-2011.

**ENABLING DECISIONS AT THE
SPEED OF CONSUMER BEHAVIOR**

THE MARK CONSISTS OF STANDARD CHARACTERS WITHOUT CLAIM TO ANY PARTICULAR FONT, STYLE, SIZE, OR COLOR.

CLASS 35—ADVERTISING AND BUSINESS

FOR BUSINESS INFORMATION SERVICES IN THE FIELD OF DATA ANALYTICS, NAMELY, DATA SELECTION, DATA ARRANGEMENT, DATA PROCESSING, DATA PRESENTATION, DATA CLEANSING AND DATA DISTRIBUTION IN THE FIELDS OF MARKETING DEMOGRAPHICS AND CONSUMER PURCHASING BEHAVIORS; BUSINESS MANAGEMENT OF CONSUMER, MARKETING, DEMOGRAPHIC AND PAYMENTS INFORMATION AND DATA OF OTHERS; BUSINESS DATA AND INFORMATION PROCESSING SERVICES, NAMELY, DATA SELECTION, DATA ARRANGEMENT, DATA PROCESSING, DATA ANALYTICS, DATA CLEANSING TO REMOVE ERRONEOUS OR UNWANTED INFORMATION RELATING THERETO, DATA MERGING, DATA PRESENTATION, AND DATA DISTRIBUTION SERVICES; PROVIDING BUSINESS INFORMATION AND REPORTS; BUSINESS ANALYSIS AND EVALUATION OF CONSUMER, MARKETING AND DEMOGRAPHIC INFORMATION; BUSINESS ANALYSIS OF CONSUMER, MARKETING, DEMOGRAPHIC AND PAYMENTS INFORMATION; BUSINESS MARKETING CONSULTATION SERVICES; MARKET RESEARCH; CONDUCTING MARKETING STUDIES; BUSINESS INFORMATION SERVICES, NAMELY, PROVIDING MARKETING INFORMATION RELATING TO THE FIELDS OF BANKING AND FINANCIAL SERVICES; PROVIDING MARKETING RESEARCH, BUSINESS RESEARCH, AND MARKET RESEARCH CONSULTING SERVICES, ALL RELATED TO THE FIELDS OF BANKING AND FINANCIAL SERVICES; PROVIDING BUSINESS STATISTICAL INFORMATION; BUSINESS MARKETING CONSULTING SERVICES IN REGARDS TO CONSUMER PURCHASING BEHAVIORS (U.S. CLS. 100, 101 AND 102).

CLASS 36—INSURANCE AND FINANCIAL

FOR FINANCIAL SERVICES, NAMELY, PROVIDING ADVISORY SERVICES IN THE FIELD OF BANKING, CREDIT AND DEBIT CARDS AND FINANCE (U.S. CLS. 100, 101 AND 102).

DAVID MURRAY, EXAMINING ATTORNEY

CLASS 35—ADVERTISING AND BUSINESS

FOR BUSINESS INFORMATION SERVICES IN THE FIELD OF DATA ANALYTICS, NAMELY, DATA SELECTION, DATA ARRANGEMENT, DATA PROCESSING, DATA PRESENTATION, DATA CLEANSING AND DATA DISTRIBUTION IN THE FIELDS OF MARKETING DEMOGRAPHICS AND CONSUMER PURCHASING BEHAVIORS; BUSINESS MANAGEMENT OF CONSUMER, MARKETING, DEMOGRAPHIC AND PAYMENTS INFORMATION AND DATA OF OTHERS; BUSINESS DATA AND INFORMATION PROCESSING SERVICES, NAMELY, DATA SELECTION, DATA ARRANGEMENT, DATA PROCESSING, DATA ANALYTICS, DATA CLEANSING TO REMOVE ERRONEOUS OR UNWANTED INFORMATION RELATING THERETO, DATA MERGING, DATA PRESENTATION, AND DATA DISTRIBUTION SERVICES; PROVIDING BUSINESS INFORMATION AND REPORTS; BUSINESS ANALYSIS AND EVALUATION OF CONSUMER, MARKETING AND DEMOGRAPHIC INFORMATION; BUSINESS ANALYSIS OF CONSUMER, MARKETING, DEMOGRAPHIC AND PAYMENTS INFORMATION; BUSINESS MARKETING CONSULTATION SERVICES; MARKET RESEARCH; CONDUCTING MARKETING STUDIES; BUSINESS INFORMATION SERVICES, NAMELY, PROVIDING MARKETING INFORMATION RELATING TO THE FIELDS OF BANKING AND FINANCIAL SERVICES; PROVIDING MARKETING RESEARCH, BUSINESS RESEARCH, AND MARKET RESEARCH CONSULTING SERVICES, ALL RELATED TO THE FIELDS OF BANKING AND FINANCIAL SERVICES; PROVIDING BUSINESS STATISTICAL INFORMATION; BUSINESS MARKETING CONSULTING SERVICES IN REGARDS TO CONSUMER PURCHASING BEHAVIORS (U.S. CLS. 100, 101 AND 102).

CLASS 36—INSURANCE AND FINANCIAL

FOR FINANCIAL SERVICES, NAMELY, PROVIDING ADVISORY SERVICES IN THE FIELD OF BANKING, CREDIT AND DEBIT CARDS AND FINANCE (U.S. CLS. 100, 101 AND 102).

DAVID MURRAY, EXAMINING ATTORNEY

SN 85-457,609. ROBERTS, TRICIA, DUNLAP, IA. FILED 10-27-2011.



THE MARK CONSISTS OF AN IMAGE OF A RIBBON IN FANCIFUL FORM.

CLASS 14—JEWELRY

FOR JEWELRY (U.S. CLS. 2, 27, 28 AND 50).

CLASS 25—CLOTHING

FOR CLOTHING, WEARING APPAREL AND ACCESSORIES, NAMELY, SHIRTS, SWEATSHIRTS, T-SHIRTS, JERSEYS, SWEATERS, CARDIGANS, TANK TOPS, HALTER TOPS, PANTS, SWEAT PANTS, SHORTS; LADIES' AND MEN'S UNDERWEAR, NAMELY, BRIEFS, BOXER SHORTS, BOY SHORTS, THONGS, G-STRINGS, BRAS, TEDDIES, SLIPS, GARTER BELTS, SARONGS; SLEEPWEAR, NAMELY, BATHROBES, NIGHT SHIRTS, PAJAMAS, SLEEPING GOWNS; KIMONOS; COATS, JACKETS, VESTS, DRESSES, SKIRTS, BLOUSES, ROMPERS, SWIMWEAR; RAINWEAR, NAMELY, RAINCOATS, RAIN BONNETS, RAIN BOOTS, AND RAIN CAPES; TIES, ASCOTS, BELTS, SCARVES; FOOTWEAR, NAMELY, SHOES, BOOTS, SLIPPERS, SANDALS SOCKS, TIGHTS AND STOCKINGS; HEADWEAR, NAMELY, HATS, VISORS, AND CAPS; APRONS; EAR MUFFS; BELTS; WRISTBANDS; BANDANAS (U.S. CLS. 22 AND 39).

CLASS 36—INSURANCE AND FINANCIAL

FOR CHARITABLE FUNDRAISING SERVICES (U.S. CLS. 100, 101 AND 102).

CLASS 44—MEDICAL, BEAUTY AND AGRICULTURAL SERVICES

FOR PROVIDING A WEBSITE VIA A GLOBAL COMPUTER NETWORK FEATURING INFORMATION IN THE FIELDS OF BREAST CANCER AWARENESS AND PREVENTION (U.S. CLS. 100 AND 101).

GIANCARLO CASTRO, EXAMINING ATTORNEY

SN 85-457,722. PIXELFISH, INC., TORRANCE, CA. FILED 10-27-2011.

PIXELFISH

THE MARK CONSISTS OF STANDARD CHARACTERS WITHOUT CLAIM TO ANY PARTICULAR FONT, STYLE, SIZE, OR COLOR.

CLASS 35—ADVERTISING AND BUSINESS

FOR ADVERTISING AND MARKETING SERVICES, NAMELY, PROMOTING THE GOODS, SERVICES, BRAND IDENTITY AND COMMERCIAL INFORMATION AND NEWS OF THIRD PARTIES THROUGH AUDIO, VIDEO, DIGITAL AND ON-LINE MEDIUMS; PROMOTIONAL MARKETING SERVICES USING AUDIOVISUAL MEDIA (U.S. CLS. 100, 101 AND 102).

FIRST USE 3-1-2006; IN COMMERCE 3-1-2006.

CLASS 41—EDUCATION AND ENTERTAINMENT

FOR VIDEO PRODUCTION SERVICES (U.S. CLS. 100, 101 AND 107).

FIRST USE 3-1-2006; IN COMMERCE 3-1-2006.

CLASS 42—SCIENTIFIC AND COMPUTER SERVICES

FOR SOFTWARE AS A SERVICE (SAAS) SERVICES FEATURING SOFTWARE FOR CREATING, DISTRIBUTING AND OPTIMIZING VIDEO; COMPUTER SERVICES, NAMELY, SEARCH ENGINE OPTIMIZATION; COMPUTER PROGRAMMING SERVICES, NAMELY, ONLINE VIDEO CONTENT OPTIMIZATION (U.S. CLS. 100 AND 101).

FIRST USE 3-1-2006; IN COMMERCE 3-1-2006.

DOMINIC FATHY, EXAMINING ATTORNEY

SN 85-459,012. EASTERN METAL SUPPLY INC., LAKE WORTH, FL. FILED 10-28-2011.

EAS

THE MARK CONSISTS OF STANDARD CHARACTERS WITHOUT CLAIM TO ANY PARTICULAR FONT, STYLE, SIZE, OR COLOR.

CLASS 6—METAL GOODS

FOR DOORS AND WINDOWS OF METAL (U.S. CLS. 2, 12, 13, 14, 23, 25 AND 50).

CLASS 19—NON-METALLIC BUILDING MATERIALS

FOR NON-METAL WINDOWS AND DOORS (U.S. CLS. 1, 12, 33 AND 50).

CHRISTINA SOBRAL, EXAMINING ATTORNEY

SN 85-460,292. UNITEDHEALTH GROUP INCORPORATED, MINNETONKA, MN. FILED 10-31-2011.

**UNITEDHEALTHCARE
SIGNATUREVALUE**

THE MARK CONSISTS OF STANDARD CHARACTERS WITHOUT CLAIM TO ANY PARTICULAR FONT, STYLE, SIZE, OR COLOR.

OWNER OF U.S. REG. NOS. 1,967,622, 3,561,000 AND OTHERS.

CLASS 35—ADVERTISING AND BUSINESS

FOR HEALTH CARE COST MANAGEMENT AND COST CONTAINMENT SERVICES; HEALTH CARE COST MANAGEMENT SERVICES FOR HEALTH CARE BENEFIT PLANS AND HEALTH CARE SERVICE PLANS OF OTHERS; HEALTH CARE UTILIZATION MANAGEMENT SERVICES; HEALTH CARE UTILIZATION, REVIEW AND COST CONTAINMENT SERVICES (U.S. CLS. 100, 101 AND 102).

CLASS 36—INSURANCE AND FINANCIAL

FOR ORGANIZATION AND ADMINISTRATION OF PREPAID HEALTH CARE PLANS; ORGANIZATION AND ADMINISTRATION OF HEALTH CARE BENEFIT PLANS AND HEALTH CARE SERVICE PLANS; ADMINISTRATION OF EMPLOYEE BENEFIT PLANS CONCERNING INSURANCE AND FINANCE; INSURANCE UNDERWRITING IN THE FIELD OF HEALTH FOR HEALTH CARE INSURANCE; INSURANCE SERVICES, NAMELY, CLAIMS ADMINISTRATION OF HEALTH CARE BENEFIT PLANS AND HEALTH CARE SERVICE PLANS; ORGANIZATION AND ADMINISTRATION OF NETWORKS OF PREFERRED HEALTH CARE PROVIDERS (U.S. CLS. 100, 101 AND 102).

CLASS 44—MEDICAL, BEAUTY AND AGRICULTURAL SERVICES

FOR MANAGED HEALTH CARE SERVICES; HEALTH CARE IN THE NATURE OF HEALTH MAINTENANCE ORGANIZATIONS (HMOS) AND PREFERRED PROVIDER ORGANIZATIONS (PPOS); PROVIDING HEALTH INFORMATION (U.S. CLS. 100 AND 101).
ERNEST SHOSHO, EXAMINING ATTORNEY

SN 85-461,251. DJP CONCEPTS IP SUB, LLC, MIAMI, FL. FILED 11-1-2011.

DMSX

THE MARK CONSISTS OF STANDARD CHARACTERS WITHOUT CLAIM TO ANY PARTICULAR FONT, STYLE, SIZE, OR COLOR.

CLASS 18—LEATHER GOODS

FOR HANDBAGS; WALLETS (U.S. CLS. 1, 2, 3, 22 AND 41).

CLASS 25—CLOTHING

FOR BELTS FOR CLOTHING; FOOTWEAR (U.S. CLS. 22 AND 39).
ANDREA HACK, EXAMINING ATTORNEY

SN 85-462,955. LITTLE BABY'S ICE CREAM, LLC, PHILADELPHIA, PA. FILED 11-2-2011.

LITTLE BABY'S

THE MARK CONSISTS OF STANDARD CHARACTERS WITHOUT CLAIM TO ANY PARTICULAR FONT, STYLE, SIZE, OR COLOR.

CLASS 30—STAPLE FOODS

FOR ICE CREAM (U.S. CL. 46).
FIRST USE 3-0-2011; IN COMMERCE 3-0-2011.

CLASS 35—ADVERTISING AND BUSINESS

FOR STREET VENDOR SERVICES FEATURING ICE CREAM (U.S. CLS. 100, 101 AND 102).
FIRST USE 3-0-2011; IN COMMERCE 3-0-2011.

CLASS 43—HOTEL AND RESTAURANT SERVICES

FOR ICE CREAM SHOP SERVICES IN THE NATURE OF A RESTAURANT; MOBILE RESTAURANT SERVICES (U.S. CLS. 100 AND 101).
FIRST USE 3-0-2011; IN COMMERCE 3-0-2011.
ADA HAN, EXAMINING ATTORNEY

SN 85-463,218. APPINESS, LLC, FERNANDINA BEACH, FL. FILED 11-3-2011.

PIXEL ZOMBIES

THE MARK CONSISTS OF STANDARD CHARACTERS WITHOUT CLAIM TO ANY PARTICULAR FONT, STYLE, SIZE, OR COLOR.
NO CLAIM IS MADE TO THE EXCLUSIVE RIGHT TO USE "PIXEL" IN INTERNATIONAL CLASS 9, APART FROM THE MARK AS SHOWN.

CLASS 9—ELECTRICAL AND SCIENTIFIC APPARATUS

FOR COMPUTER APPLICATION SOFTWARE FOR MOBILE PHONES, TABLET COMPUTERS, AND HANDHELD COMPUTING DEVICES, NAMELY, SOFTWARE FOR AUDIO, VISUAL, AND GAMING ENTERTAINMENT (U.S. CLS. 21, 23, 26, 36 AND 38).

CLASS 25—CLOTHING

FOR BASEBALL CAPS AND HATS; JACKETS; PANTS; SHIRTS; SHOES (U.S. CLS. 22 AND 39).

CLASS 28—TOYS AND SPORTING GOODS

FOR BOARD GAMES; STUFFED AND PLUSH TOYS; TOY ACTION FIGURES AND ACCESSORIES THEREFOR (U.S. CLS. 22, 23, 38 AND 50).
ANNE E. GUSTASON, EXAMINING ATTORNEY

SN 85-464,280. BOYD, JAMES, BLUE KNOB, AUSTRALIA, FILED 11-4-2011.

SN 85-468,493. LINK SNACKS, INC., MINONG, WI. FILED 11-9-2011.



NO CLAIM IS MADE TO THE EXCLUSIVE RIGHT TO USE "FINGER LIMES", "LIME", "CITRUS CAVIAR", OR THE PICTORIAL REPRESENTATION OF A FINGER LIME, APART FROM THE MARK AS SHOWN.

THE MARK CONSISTS OF THE LITERAL ELEMENTS "FINGERLIMES LIMEBURST CITRUS CAVIAR" WRITTEN IN STYLIZED FORM, WHEREIN THE WORD "FINGERLIMES" IS PLACED AT THE TOP IN SMALL FONTS ABOVE THE WORD "LIMEBURST" AND THE "B" IN THE WORD "LIMEBURST" IS TILTED TOWARDS LEFT AND THE WORDS "CITRUS CAVIAR" ARE PLACED BELOW IT AND AN IMAGE OF A CITRUS FRUIT DIVIDED INTO TWO IS PLACED WITH PULP COMING OUT FROM IT WITH IMAGES OF BUBBLES GOING UPWARDS WITH SUN RAYS IN THE BACKGROUND AS SHOWN IN THE MARK.

CLASS 29—MEATS AND PROCESSED FOODS

FOR FRUIT PULP; FROZEN FRUIT (U.S. CL. 46).
FIRST USE 10-31-2008; IN COMMERCE 10-31-2008.

CLASS 31—NATURAL AGRICULTURAL PRODUCTS

FOR FRESH FRUIT (U.S. CLS. 1 AND 46).
FIRST USE 10-31-2008; IN COMMERCE 10-31-2008.
KIMBERLY FRYE, EXAMINING ATTORNEY

SN 85-465,269. PROTICA INC., WHITEHALL, PA. FILED 11-4-2011.

Mr LunchBox

THE MARK CONSISTS OF STANDARD CHARACTERS WITHOUT CLAIM TO ANY PARTICULAR FONT, STYLE, SIZE, OR COLOR.

CLASS 5—PHARMACEUTICALS

FOR DIETARY AND NUTRITIONAL SUPPLEMENTS (U.S. CLS. 6, 18, 44, 46, 51 AND 52).

CLASS 29—MEATS AND PROCESSED FOODS

FOR PRE-PACKAGED DINNERS CONSISTING PRIMARILY OF FRUITS AND VEGETABLES (U.S. CL. 46).
ALEXANDER L. POWERS, EXAMINING ATTORNEY

DOUBLE DIPPERS

THE MARK CONSISTS OF STANDARD CHARACTERS WITHOUT CLAIM TO ANY PARTICULAR FONT, STYLE, SIZE, OR COLOR.

CLASS 29—MEATS AND PROCESSED FOODS

FOR MEAT SNACKS (U.S. CL. 46).

CLASS 30—STAPLE FOODS

FOR DIPPING SAUCES (U.S. CL. 46).
KIMBERLY PERRY, EXAMINING ATTORNEY

SN 85-468,524. LIVING INTENTIONALLY FOR EXCELLENCE, LLC, FLINT, MI. FILED 11-9-2011.



THE MARK CONSISTS OF A CARTOON CHARACTER OF A BOY WITH WAVY HAIR AND A MISCHIEVOUS SMILE STANDING WITH ARMS CROSSED.

CLASS 9—ELECTRICAL AND SCIENTIFIC APPARATUS

FOR PRE-RECORDED AUDIO CASSETTES AND PRE-RECORDED DIGITAL AUDIO AND VIDEO DISKS FEATURING MOTIVATIONAL AND SELF-IMPROVEMENT INSTRUCTION (U.S. CLS. 21, 23, 26, 36 AND 38).
FIRST USE 9-13-2010; IN COMMERCE 9-13-2010.

CLASS 16—PAPER GOODS AND PRINTED MATTER

FOR BOOKS, PRINTED LECTURES, PRINTED LESSONS AND PRINTED EDUCATIONAL MATERIALS, ALL IN THE FIELD OF MOTIVATIONAL AND SELF-IMPROVEMENT INSTRUCTION (U.S. CLS. 2, 5, 22, 23, 29, 37, 38 AND 50).

CLASS 41—EDUCATION AND ENTERTAINMENT

FOR EDUCATIONAL SERVICES, NAMELY, CONDUCTING SEMINARS IN THE FIELD OF MOTIVATIONAL AND SELF-IMPROVEMENT INSTRUCTION AND BOOKS, LECTURES, LESSONS AND EDUCATIONAL MATERIALS IN THE FIELD OF MOTIVATIONAL AND SELF-IMPROVEMENT INSTRUCTION (U.S. CLS. 100, 101 AND 107).

JOHN E. MICHOS, EXAMINING ATTORNEY

SN 85-468,848. GUTHY-RENKER LLC, PALM DESERT, CA. FILED 11-9-2011.

PROACTIV FLOURISH

THE MARK CONSISTS OF STANDARD CHARACTERS WITHOUT CLAIM TO ANY PARTICULAR FONT, STYLE, SIZE, OR COLOR.

OWNER OF U.S. REG. NOS. 2,574,142, 3,804,708 AND OTHERS.

CLASS 3—COSMETICS AND CLEANING PREPARATIONS

FOR SKIN AND BODY CARE PREPARATIONS, NAMELY, SKIN CLEANSERS, SKIN MOISTURIZERS, SKIN LOTIONS, SKIN SOAPS, SUN SCREEN PREPARATIONS, COSMETICS, NON-MEDICATED HAIR CARE PREPARATIONS, NAIL CARE PREPARATIONS, NON-MEDICATED SKIN CARE PREPARATIONS, COLOGNES, PERFUMES AND TOOTH WHITENING PREPARATIONS (U.S. CLS. 1, 4, 6, 50, 51 AND 52).

CLASS 5—PHARMACEUTICALS

FOR ACNE TREATMENT PREPARATIONS (U.S. CLS. 6, 18, 44, 46, 51 AND 52).

HENRY S. ZAK, EXAMINING ATTORNEY



SN 85-468,575. LIVING INTENTIONALLY FOR EXCELLENCE, LLC, FLINT, MI. FILED 11-9-2011.

NO CLAIM IS MADE TO THE EXCLUSIVE RIGHT TO USE "FAMILY" AND "FINANCES" AND "FITNESS", APART FROM THE MARK AS SHOWN.

THE MARK CONSISTS OF A SHIP'S WHEEL WITH LIFE AT THE CENTER AND "FAITH, FAMILY, FINANCES, FOLLOWING, FREEDOM, FRIENDS AND FUN" ON THE SPOKES.

SN 85-469,097. ENZO LIFE SCIENCES, INC., FARMINGDALE, NY. FILED 11-10-2011.

CLASS 9—ELECTRICAL AND SCIENTIFIC APPARATUS

FOR PRE-RECORDED AUDIO CASSETTES AND PRE-RECORDED DIGITAL AUDIO AND VIDEO DISKS FEATURING MOTIVATIONAL AND SELF-IMPROVEMENT INSTRUCTION (U.S. CLS. 21, 23, 26, 36 AND 38). FIRST USE 10-21-2011; IN COMMERCE 10-21-2011.

CLASS 16—PAPER GOODS AND PRINTED MATTER

FOR BOOKS, PRINTED LECTURES, PRINTED LESSONS AND PRINTED EDUCATIONAL MATERIALS, ALL IN THE FIELD OF MOTIVATIONAL AND SELF-IMPROVEMENT INSTRUCTION (U.S. CLS. 2, 5, 22, 23, 29, 37, 38 AND 50).

CLASS 41—EDUCATION AND ENTERTAINMENT

FOR EDUCATIONAL SERVICES, NAMELY, CONDUCTING SEMINARS IN THE FIELD OF MOTIVATIONAL AND SELF-IMPROVEMENT INSTRUCTION AND ON-LINE PUBLICATION OF BOOKS, LECTURES, LESSONS AND EDUCATIONAL MATERIALS IN THE FIELD OF MOTIVATIONAL AND SELF-IMPROVEMENT INSTRUCTION (U.S. CLS. 100, 101 AND 107).

FIRST USE 10-21-2011; IN COMMERCE 10-21-2011.

JOHN E. MICHOS, EXAMINING ATTORNEY

AMPEPROBE

THE MARK CONSISTS OF STANDARD CHARACTERS WITHOUT CLAIM TO ANY PARTICULAR FONT, STYLE, SIZE, OR COLOR.

CLASS 1—CHEMICALS

FOR REAGENTS FOR SCIENTIFIC RESEARCH USE IN THE FIELD OF MEDICINE; REAGENT KITS COMPRISING REAGENTS FOR SCIENTIFIC RESEARCH USE IN THE FIELD OF MEDICINE; DIAGNOSTIC REAGENTS FOR SCIENTIFIC OR RESEARCH USE IN THE FIELD OF MEDICINE; REAGENTS FOR IN VITRO SCIENTIFIC RESEARCH USE IN THE FIELD OF MEDICINE (U.S. CLS. 1, 5, 6, 10, 26 AND 46).

CLASS 5—PHARMACEUTICALS

FOR MEDICAL DIAGNOSTIC REAGENTS (U.S. CLS. 6, 18, 44, 46, 51 AND 52).

HENRY S. ZAK, EXAMINING ATTORNEY

SN 85-479,873. THE ASSOCIATION OF POOL AND SPA PROFESSIONALS, ALEXANDRIA, VA. FILED 11-23-2011.



THE MARK CONSISTS OF THE STYLIZED LETTERS "APSP", WHERE THE LETTER "A" CONSISTS OF AN INVERTED "V". TO THE LEFT OF THE STYLIZED LETTERS IS THE DESIGN OF TWO CONCENTRIC CIRCLES BISECTED BY THREE WAVY BANDS, WHERE THE OUTER CIRCLE IS SHADED IN THE BOTTOM PART OF THE DESIGN, AND THE INNER CIRCLE IS SHADED IN THE TOP PART OF THE DESIGN.

CLASS 9—ELECTRICAL AND SCIENTIFIC APPARATUS

FOR ELECTRONIC PUBLICATIONS IN THE NATURE OF BOOKS, MAGAZINES, MANUALS, TEXTBOOKS, WORKBOOKS, NEWSLETTERS, BROCHURES, EDUCATIONAL COURSE MATERIALS, INFORMATION BULLETINS, AND CURRICULUM OUTLINES IN THE FIELD OF POOL AND SPA TECHNOLOGY THAT ARE DOWNLOADABLE FROM THE INTERNET; DOWNLOADABLE MULTIMEDIA FILES CONTAINING artwork, TEXT, AUDIO, VIDEO, AND INTERNET WEB LINKS IN THE NATURE OF STANDARDS, GUIDELINES, REFERENCE MATERIALS, GLOSSARIES, PRESENTATIONS, FORMS, PHOTOGRAPHIC IMAGES, CHARTS, DIAGRAMS, TABLES, ILLUSTRATIONS, GRAPHICS, EXAMINATIONS, QUIZZES, SURVEYS, AND ASSESSMENTS RELATING TO THE FIELD OF POOL AND SPA TECHNOLOGY THAT ARE DOWNLOADABLE FROM THE INTERNET; ELECTRONIC PUBLICATIONS RECORDED ON CD-ROM, AUDIO-TAPE AND VIDEOTAPE, NAMELY, BOOKS, MAGAZINES, MANUALS, TEXTBOOKS, WORKBOOKS, NEWSLETTERS, BROCHURES, EDUCATIONAL COURSE MATERIALS, INFORMATION BULLETINS, AND CURRICULUM OUTLINES IN THE FIELD OF POOL AND SPA TECHNOLOGY; DIGITAL MATERIALS, NAMELY, CD-ROMS, AUDIOTAPES AND VIDEOTAPES FEATURING STANDARDS, GUIDELINES, REFERENCE MATERIALS, GLOSSARIES, PRESENTATIONS, FORMS, PHOTOGRAPHIC IMAGES, CHARTS, DIAGRAMS, TABLES, ILLUSTRATIONS, GRAPHICS, EXAMINATIONS, QUIZZES, SURVEYS, AND ASSESSMENTS RELATING TO THE FIELD OF POOL AND SPA TECHNOLOGY (U.S. CLS. 21, 23, 26, 36 AND 38).

CLASS 16—PAPER GOODS AND PRINTED MATTER

FOR PRINT PUBLICATIONS, NAMELY, BOOKS, MAGAZINES, NEWSLETTER, EDUCATIONAL COURSE MATERIALS AND REFERENCE BOOKS AND GUIDES IN THE FIELD OF POOL AND SPA TECHNOLOGY (U.S. CLS. 2, 5, 22, 23, 29, 37, 38 AND 50).

CLASS 35—ADVERTISING AND BUSINESS

FOR TRADE ASSOCIATION SERVICES, NAMELY, PROMOTING THE INTERESTS OF POOL AND SPA PROFESSIONALS; TRADE ASSOCIATION SERVICES, NAMELY, POLITICAL ADVOCACY SERVICES AT ALL LEVELS OF GOVERNMENT PROMOTING PUBLIC AWARENESS OF ISSUES RELATING TO POOLS AND SPAS AND PROFESSIONALS IN THE POOL AND SPA INDUSTRY (U.S. CLS. 100, 101 AND 102).

CLASS 41—EDUCATION AND ENTERTAINMENT

FOR EDUCATIONAL SERVICES, NAMELY, CONDUCTING CLASSES AND SEMINARS IN THE FIELD OF POOL AND SPA TECHNOLOGY (U.S. CLS. 100, 101 AND 107).
JAY BESCH, EXAMINING ATTORNEY

SN 85-479,918. THE ASSOCIATION OF POOL AND SPA PROFESSIONALS, ALEXANDRIA, VA. FILED 11-23-2011.



THE MARK CONSISTS OF THE STYLIZED LETTERS "APSP", WHERE THE LETTER "A" CONSISTS OF AN INVERTED "V". ABOVE THE STYLIZED LETTERS IS THE DESIGN OF TWO CONCENTRIC CIRCLES BISECTED BY THREE WAVY BANDS, WHERE THE OUTER CIRCLE IS SHADED IN THE BOTTOM PART OF THE DESIGN, AND THE INNER CIRCLE IS SHADED IN THE TOP PART OF THE DESIGN.

CLASS 9—ELECTRICAL AND SCIENTIFIC APPARATUS

FOR ELECTRONIC PUBLICATIONS IN THE NATURE OF BOOKS, MAGAZINES, MANUALS, TEXTBOOKS, WORKBOOKS, NEWSLETTERS, BROCHURES, EDUCATIONAL COURSE MATERIALS, INFORMATION BULLETINS, AND CURRICULUM OUTLINES IN THE FIELD OF POOL AND SPA TECHNOLOGY THAT ARE DOWNLOADABLE FROM THE INTERNET; DOWNLOADABLE MULTIMEDIA FILES CONTAINING artwork, TEXT, AUDIO, VIDEO, AND INTERNET WEB LINKS IN THE NATURE OF STANDARDS, GUIDELINES, REFERENCE MATERIALS, GLOSSARIES, PRESENTATIONS, FORMS, PHOTOGRAPHIC IMAGES, CHARTS, DIAGRAMS, TABLES, ILLUSTRATIONS, GRAPHICS, EXAMINATIONS, QUIZZES, SURVEYS, AND ASSESSMENTS RELATING TO THE FIELD OF POOL AND SPA TECHNOLOGY THAT ARE DOWNLOADABLE FROM THE INTERNET; ELECTRONIC PUBLICATIONS RECORDED ON CD-ROM, AUDIO-TAPE AND VIDEOTAPE, NAMELY, BOOKS, MAGAZINES, MANUALS, TEXTBOOKS, WORKBOOKS, NEWSLETTERS, BROCHURES, EDUCATIONAL COURSE MATERIALS, INFORMATION BULLETINS, AND CURRICULUM OUTLINES IN THE FIELD OF POOL AND SPA TECHNOLOGY; DIGITAL MATERIALS, NAMELY, CD-ROMS, AUDIOTAPES AND VIDEOTAPES FEATURING STANDARDS, GUIDELINES, REFERENCE MATERIALS, GLOSSARIES, PRESENTATIONS, FORMS, PHOTOGRAPHIC IMAGES, CHARTS, DIAGRAMS, TABLES, ILLUSTRATIONS, GRAPHICS, EXAMINATIONS, QUIZZES, SURVEYS, AND ASSESSMENTS RELATING TO THE FIELD OF POOL AND SPA TECHNOLOGY (U.S. CLS. 21, 23, 26, 36 AND 38).

CLASS 16—PAPER GOODS AND PRINTED MATTER

FOR PRINT PUBLICATIONS, NAMELY, BOOKS, MAGAZINES, NEWSLETTER, EDUCATIONAL COURSE MATERIALS AND REFERENCE BOOKS AND GUIDES IN THE FIELD OF POOL AND SPA TECHNOLOGY (U.S. CLS. 2, 5, 22, 23, 29, 37, 38 AND 50).

CLASS 35—ADVERTISING AND BUSINESS

FOR TRADE ASSOCIATION SERVICES, NAMELY, PROMOTING THE INTERESTS OF POOL AND SPA PROFESSIONALS; TRADE ASSOCIATION SERVICES, NAMELY, POLITICAL ADVOCACY SERVICES AT ALL LEVELS OF GOVERNMENT PROMOTING PUBLIC AWARENESS OF ISSUES RELATING TO POOLS AND SPAS AND PROFESSIONALS IN THE POOL AND SPA INDUSTRY (U.S. CLS. 100, 101 AND 102).

CLASS 41—EDUCATION AND ENTERTAINMENT

FOR EDUCATIONAL SERVICES, NAMELY, CONDUCTING CLASSES AND SEMINARS IN THE FIELD OF POOL AND SPA TECHNOLOGY (U.S. CLS. 100, 101 AND 107).

JAY BESCH, EXAMINING ATTORNEY

JOHN HWANG, EXAMINING ATTORNEY

SN 85-479,975. SAN ANTONIO WINERY, INC., LOS ANGELES, CA. FILED 11-23-2011.

SN 85-483,840. SPTC, INC., RENO, NV. FILED 11-30-2011.

CAPITOL MILL BREWERY

THE MARK CONSISTS OF STANDARD CHARACTERS WITHOUT CLAIM TO ANY PARTICULAR FONT, STYLE, SIZE, OR COLOR.

NO CLAIM IS MADE TO THE EXCLUSIVE RIGHT TO USE "BREWERY", APART FROM THE MARK AS SHOWN.

CLASS 32—LIGHT BEVERAGES

FOR BEER (U.S. CLS. 45, 46 AND 48).

CLASS 43—HOTEL AND RESTAURANT SERVICES

FOR RESTAURANT AND BAR SERVICES (U.S. CLS. 100 AND 101).

CHRISTINE MARTIN, EXAMINING ATTORNEY

SN 85-481,390. SAMSUNG ELECTRONICS CO., LTD., SUWON-SI, GYEONGGI-DO, REPUBLIC OF KOREA, FILED 11-28-2011.

SAMSUNG SMART HomeNet

THE MARK CONSISTS OF STANDARD CHARACTERS WITHOUT CLAIM TO ANY PARTICULAR FONT, STYLE, SIZE, OR COLOR.

OWNER OF U.S. REG. NOS. 1,164,353, 4,050,287 AND OTHERS.

NO CLAIM IS MADE TO THE EXCLUSIVE RIGHT TO USE "SMART", APART FROM THE MARK AS SHOWN.

CLASS 7—MACHINERY

FOR ELECTRIC WASHING MACHINES FOR HOUSEHOLD PURPOSES; ELECTRIC VACUUM CLEANERS; ELECTRIC FOOD BLENDERS; DISHWASHING MACHINES; ELECTRIC MIXERS FOR HOUSEHOLD PURPOSES (U.S. CLS. 13, 19, 21, 23, 31, 34 AND 35).

CLASS 11—ENVIRONMENTAL CONTROL APPARATUS

FOR ELECTRIC REFRIGERATORS FOR HOUSEHOLD PURPOSES; WATER PURIFIERS FOR HOUSEHOLD PURPOSES; HUMIDIFIERS; AIR CONDITIONERS; MICROWAVE OVENS; GAS COOKING OVENS; GAS RANGES; ELECTRIC FANS; AIR PURIFIERS (U.S. CLS. 13, 21, 23, 31 AND 34).

SEE THE BIGGER PICTURE

THE MARK CONSISTS OF STANDARD CHARACTERS WITHOUT CLAIM TO ANY PARTICULAR FONT, STYLE, SIZE, OR COLOR.

CLASS 35—ADVERTISING AND BUSINESS

FOR ART DEALERSHIP (U.S. CLS. 100, 101 AND 102).

CLASS 36—INSURANCE AND FINANCIAL

FOR VALUATION OF ART (U.S. CLS. 100, 101 AND 102).

CLASS 41—EDUCATION AND ENTERTAINMENT

FOR ART EXHIBITION SERVICES; ART GALLERY SERVICES (U.S. CLS. 100, 101 AND 107).

CHRIS WELLS, EXAMINING ATTORNEY

SN 85-485,174. SKINAGAIN, LLC, CARLSBAD, CA. FILED 12-1-2011.

FacePro

THE MARK CONSISTS OF STANDARD CHARACTERS WITHOUT CLAIM TO ANY PARTICULAR FONT, STYLE, SIZE, OR COLOR.

CLASS 3—COSMETICS AND CLEANING PREPARATIONS

FOR NON-MEDICATED SKIN CARE PREPARATIONS (U.S. CLS. 1, 4, 6, 50, 51 AND 52).

CLASS 10—MEDICAL APPARATUS

FOR COSMETIC APPARATUS, NAMELY, LIGHT BASED DEVICES PROVIDING MAINLY PULSED LIGHT FOR PERFORMING NON-ABLATIVE AESTHETIC SKIN TREATMENT PROCEDURES; ELECTRICALLY-POWERED APPARATUS FOR TREATING SKIN BY APPLYING LOW LEVEL LIGHT AND SONIC VIBRATIONS TO THE SKIN; ELECTROMEDICAL REHABILITATIVE AND PAIN MANAGEMENT PRODUCTS FOR CLINICAL AND HOME USE, NAMELY, ELECTRICAL NERVE AND MUSCLE STIMULATORS, ULTRASONIC STIMULATORS, MAGNET THERAPY STIMULATORS AND LASER THERAPY STIMULATORS; ELECTRONIC AESTHETIC SKIN TREATMENT DEVICES USING LIGHT EMITTING DIODES, NAMELY, INFRARED, RED, ORANGE, YELLOW, GREEN, AND BLUE WAVELENGTHS FOR GENERATING LIGHT RAYS; ELECTRONIC LIGHT THERAPY APPARATUS FOR THE SKIN; ELECTRONIC STIMULATOR FOR THE SKIN; LASERS FOR THE COSMETIC TREATMENT OF THE FACE AND SKIN; LIGHT EMITTING DEVICES, NAMELY, LAMPS AND LED DEVICES FOR TREATMENT OF A VARIETY OF SKIN CONDITIONS; LIGHT-BASED MEDICAL DEVICES, NAMELY, A LIGHT EMITTING DIODE (LED) DEVICE FOR INCREASING THE HUMAN BODY'S OWN PRODUCTION OF COLLAGEN (U.S. CLS. 26, 39 AND 44).

WILLIAM VERHOSEK, EXAMINING ATTORNEY

SN 85-485,390. SKINAGAIN, LLC, CARLSBAD, CA. FILED 12-1-2011.

SkinAgain Clear

THE MARK CONSISTS OF STANDARD CHARACTERS WITHOUT CLAIM TO ANY PARTICULAR FONT, STYLE, SIZE, OR COLOR.

OWNER OF U.S. REG. NOS. 3,649,916 AND 3,916,553.

CLASS 3—COSMETICS AND CLEANING PREPARATIONS

FOR NON-MEDICATED SKIN CARE PREPARATIONS (U.S. CLS. 1, 4, 6, 50, 51 AND 52).

CLASS 5—PHARMACEUTICALS

FOR MEDICATED SKIN CARE PREPARATIONS (U.S. CLS. 6, 18, 44, 46, 51 AND 52).

WILLIAM VERHOSEK, EXAMINING ATTORNEY

SN 85-485,631. RAMIREZ MORELES, SELOMITH, IRAPUATO, MEXICO, FILED 12-2-2011.

NEEMA

THE MARK CONSISTS OF STANDARD CHARACTERS WITHOUT CLAIM TO ANY PARTICULAR FONT, STYLE, SIZE, OR COLOR.

THE NAME(S), PORTRAIT(S), AND/OR SIGNATURE(S) SHOWN IN THE MARK DOES NOT IDENTIFY A PARTICULAR LIVING INDIVIDUAL.

THE WORDING "NEEMA" HAS NO MEANING IN A FOREIGN LANGUAGE.

CLASS 3—COSMETICS AND CLEANING PREPARATIONS

FOR COSMETIC CREAMS FOR SKIN CARE (U.S. CLS. 1, 4, 6, 50, 51 AND 52).

FIRST USE 1-2-2006; IN COMMERCE 10-5-2008.

CLASS 5—PHARMACEUTICALS

FOR GELS, CREAMS AND SOLUTIONS FOR DERMATOLOGICAL USE (U.S. CLS. 6, 18, 44, 46, 51 AND 52).

FIRST USE 1-2-2006; IN COMMERCE 10-5-2008.

ANNE MADDEN, EXAMINING ATTORNEY

SN 85-486,239. S. C. JOHNSON & SON, INC., RACINE, WI. FILED 12-2-2011.

IMAGINED BY YOU. INSPIRED
BY SPRING.

THE MARK CONSISTS OF STANDARD CHARACTERS WITHOUT CLAIM TO ANY PARTICULAR FONT, STYLE, SIZE, OR COLOR.

CLASS 3—COSMETICS AND CLEANING PREPARATIONS

FOR ALL PURPOSE CLEANERS, GLASS AND HOUSEHOLD SURFACE CLEANERS (U.S. CLS. 1, 4, 6, 50, 51 AND 52).

CLASS 4—LUBRICANTS AND FUELS

FOR CANDLES (U.S. CLS. 1, 6 AND 15).

CLASS 5—PHARMACEUTICALS

FOR AIR FRESHENERS, DEODORIZER FOR FABRIC, CARPET AND UPHOLSTERY (U.S. CLS. 6, 18, 44, 46, 51 AND 52).

DAVID C. REIHNER, EXAMINING ATTORNEY

SN 85-488,285. MAYTAG PROPERTIES, LLC, ST. JOSEPH, MI. FILED 12-6-2011.



NO CLAIM IS MADE TO THE EXCLUSIVE RIGHT TO USE "COMMERCIAL LAUNDRY", APART FROM THE MARK AS SHOWN.

THE MARK CONSISTS OF THE WORDS "MAYTAG COMMERCIAL LAUNDRY" WITHIN A SHIELD.

CLASS 7—MACHINERY

FOR CLOTHES WASHING MACHINES (U.S. CLS. 13, 19, 21, 23, 31, 34 AND 35).

CLASS 11—ENVIRONMENTAL CONTROL APPARATUS

FOR CLOTHES DRYERS (U.S. CLS. 13, 21, 23, 31 AND 34).

DAVID H. STINE, EXAMINING ATTORNEY

SN 85-493,783. FASTSIGNS INTERNATIONAL, INC., CARROLLTON, TX. FILED 12-13-2011.

MORE THAN FAST. MORE THAN
SIGNS.

THE MARK CONSISTS OF STANDARD CHARACTERS WITHOUT CLAIM TO ANY PARTICULAR FONT, STYLE, SIZE, OR COLOR.

CLASS 35—ADVERTISING AND BUSINESS

FOR ADVERTISING, MARKETING AND PROMOTION SERVICES; MARKETING SERVICES, NAMELY, PROVIDING ASSISTANCE TO OTHERS IN THE AREA OF MARKETING THEIR GOODS AND SERVICES (U.S. CLS. 100, 101 AND 102).

CLASS 40—MATERIAL TREATMENT

FOR CUSTOM MANUFACTURING FOR OTHERS OF SIGNS, BANNERS, FLAGS, DECALS, DISPLAYS, WINDOW SHADES, VEHICLE GRAPHICS, BARCODES, PRODUCT WRAPS, AND LETTERING; PRINTING SERVICES; DESIGN PRINTING FOR OTHERS (U.S. CLS. 100, 103 AND 106).

CLASS 41—EDUCATION AND ENTERTAINMENT

FOR DIGITAL IMAGING SERVICES FOR OTHERS (U.S. CLS. 100, 101 AND 107).

CLASS 42—SCIENTIFIC AND COMPUTER SERVICES

FOR GRAPHIC DESIGN FOR OTHERS; GRAPHICS ART SERVICES; CREATING WEB SITES FOR OTHERS; CREATING GRAPHICS, LOGOS, AND ILLUSTRATIONS FOR OTHERS (U.S. CLS. 100 AND 101).

DORITT L. CARROLL, EXAMINING ATTORNEY

SN 85-495,081. SLAM DUNK INVESTMENTS, LLC, DES-TRAHAN, LA. FILED 12-14-2011.



NO CLAIM IS MADE TO THE EXCLUSIVE RIGHT TO USE ".COM", APART FROM THE MARK AS SHOWN.

THE MARK CONSISTS OF THE IMAGE OF A DOG WEARING SUNGLASSES, A SHIRT, SHORTS, SHOES AND A HAT, MOVING THROUGH THE AIR TOWARD A BASKETBALL BACKBOARD HOLDING A BASKETBALL READY TO DUNK THE BASKETBALL IN THE BASKETBALL NET, WITH THE WORDING "DUNKDOG.COM" APPEARING AT THE BOTTOM OF THE IMAGE.

CLASS 25—CLOTHING

FOR APPAREL, NAMELY, SHIRTS, PANTS, JACKETS, FOOTWEAR, HATS AND CAPS (U.S. CLS. 22 AND 39).

CLASS 38—COMMUNICATION

FOR PROVIDING ON-LINE CHAT ROOMS AND ELECTRONIC BULLETIN BOARDS FOR REGISTERED USERS FOR POSTING AND TRANSMISSION OF MESSAGES, VIDEOS AND IMAGES CONCERNING BASKETBALL; PROVIDING ON-LINE FACILITIES FOR REAL-TIME INTERACTION WITH OTHER COMPUTER USERS AND ELECTRONIC BULLETIN BOARDS CONCERNING BASKETBALL; AUDIO AND VIDEO BROADCASTING SERVICES OVER THE INTERNET IN THE FIELD OF BASKETBALL; RADIO BROADCASTING CONCERNING BASKETBALL (U.S. CLS. 100, 101 AND 104).

CLASS 42—SCIENTIFIC AND COMPUTER SERVICES

FOR COMPUTER SERVICES, NAMELY, CREATING AN ON-LINE COMMUNITY FOR REGISTERED USERS TO PARTICIPATE IN DISCUSSIONS, GET FEEDBACK FROM THEIR PEERS, FORM VIRTUAL COMMUNITIES, AND ENGAGE IN SOCIAL NETWORKING SERVICES IN THE FIELD OF BASKETBALL (U.S. CLS. 100 AND 101).

CLASS 45—PERSONAL AND LEGAL SERVICES

FOR ON-LINE SOCIAL NETWORKING SERVICES IN THE FIELD OF BASKETBALL (U.S. CLS. 100 AND 101).

KAPIL BHANOT, EXAMINING ATTORNEY

SN 85-496,107. THANE INTERNATIONAL, INC., LA QUIN-TA, CA. FILED 12-15-2011.

RED FUSION

THE MARK CONSISTS OF STANDARD CHARACTERS WITHOUT CLAIM TO ANY PARTICULAR FONT, STYLE, SIZE, OR COLOR.

CLASS 10—MEDICAL APPARATUS

FOR HEATING PADS FOR MEDICAL PURPOSES (U.S. CLS. 26, 39 AND 44).

CLASS 11—ENVIRONMENTAL CONTROL APPARATUS

FOR HEATING PADS NOT FOR MEDICAL PURPOSES (U.S. CLS. 13, 21, 23, 31 AND 34).

JILL PRATER, EXAMINING ATTORNEY

SN 85-496,369. ATLANTA PEACH MOVERS, INC., DORAVILLE, GA. FILED 12-15-2011.

The Educated Mover

THE MARK CONSISTS OF STANDARD CHARACTERS WITHOUT CLAIM TO ANY PARTICULAR FONT, STYLE, SIZE, OR COLOR.

OWNER OF U.S. REG. NOS. 3,379,056 AND 3,382,375.

CLASS 39—TRANSPORTATION AND STORAGE

FOR MOVING AND STORAGE OF FURNITURE, MISCELLANEOUS HOUSEHOLD ITEMS, AND MISCELLANEOUS BUSINESS ITEMS; PACKING ARTICLES FOR TRANSPORTATION; RENTAL OF MOVING EQUIPMENT, NAMELY, PADS, STRAPS, HITCHES, DOLLIES, BOXES, CARRIERS, AND HAND TRUCKS; RENTAL OF TRUCKS; TRANSPORT OF GOODS AND FURNITURE OF OTHERS BY TRUCK, VAN, OR AUTOMOBILE (U.S. CLS. 100 AND 105).

FIRST USE 12-2-2011; IN COMMERCE 12-2-2011.

CLASS 41—EDUCATION AND ENTERTAINMENT

FOR EDUCATION SERVICES, NAMELY, PROVIDING LIVE AND ON-LINE CLASSES, SEMINARS, AND WORKSHOPS IN THE FIELD OF RESIDENTIAL AND COMMERCIAL MOVING; PROVIDING ON-LINE TRAINING FOR MOVING CLIENTS AND REAL ESTATE AGENTS IN THE FIELD OF RESIDENTIAL AND COMMERCIAL MOVING TECHNIQUES (U.S. CLS. 100, 101 AND 107).

FIRST USE 12-2-2011; IN COMMERCE 12-2-2011.

THOMAS MANOR, EXAMINING ATTORNEY

SN 85-497,229. METROPICS WIRELESS, INC., RICHARDSON, TX. FILED 12-16-2011.

EVERYBODY'S MOVING TO METRO

THE MARK CONSISTS OF STANDARD CHARACTERS WITHOUT CLAIM TO ANY PARTICULAR FONT, STYLE, SIZE, OR COLOR.

OWNER OF U.S. REG. NOS. 2,784,778, 2,865,446 AND OTHERS.

CLASS 9—ELECTRICAL AND SCIENTIFIC APPARATUS

FOR TELECOMMUNICATION HARDWARE, NAMELY, WIRELESS TELEPHONES, BATTERIES, CHARGERS, HANDS-FREE DEVICES AND WIRELESS HANDHELD COMMUNICATION DEVICES TO TRANSMIT, RECEIVE OR OTHERWISE ACCESS COMMUNICATIONS NETWORKS, FOR USE IN WIRELESS TELEPHONY AND IN THE PROVISION OF WIRELESS BROADBAND COMMUNICATION SERVICES FOR THE TRANSMISSION OF VOICE, VIDEO, IMAGES, DATA AND INFORMATION; COMPUTER APPLICATION SOFTWARE FOR MOBILE PHONES (U.S. CLS. 21, 23, 26, 36 AND 38).

CLASS 38—COMMUNICATION

FOR TELECOMMUNICATIONS SERVICES, NAMELY, WIRELESS TELEPHONY AND WIRELESS BROADBAND COMMUNICATIONS SERVICES FOR THE TRANSMISSION OF VOICE, VIDEO, IMAGES, DATA AND INFORMATION; STREAMING OF DIGITAL MEDIA CONTENT FOR OTHERS VIA COMPUTER NETWORKS; PROVIDING E-MAIL SERVICES (U.S. CLS. 100, 101 AND 104).

INGA ERVIN, EXAMINING ATTORNEY

SN 85-497,235. METROPICS WIRELESS, INC., RICHARDSON, TX. FILED 12-16-2011.



THE MARK CONSISTS OF A LOWERCASE "M" TO THE LEFT OF THE GREATER THAN SYMBOL.

CLASS 9—ELECTRICAL AND SCIENTIFIC APPARATUS

FOR TELECOMMUNICATION HARDWARE, NAMELY, WIRELESS TELEPHONES, BATTERIES, CHARGERS, HANDS-FREE DEVICES AND WIRELESS HANDHELD COMMUNICATION DEVICES TO TRANSMIT, RECEIVE OR OTHERWISE ACCESS COMMUNICATIONS NETWORKS, FOR USE IN WIRELESS TELEPHONY AND IN THE PROVISION OF WIRELESS BROADBAND COMMUNICATION SERVICES FOR THE TRANSMISSION OF VOICE, VIDEO, IMAGES, DATA AND INFORMATION; COMPUTER APPLICATION SOFTWARE FOR MOBILE PHONES (U.S. CLS. 21, 23, 26, 36 AND 38).

CLASS 38—COMMUNICATION

FOR TELECOMMUNICATIONS SERVICES, NAMELY, WIRELESS TELEPHONY AND WIRELESS BROADBAND COMMUNICATIONS SERVICES FOR THE TRANSMISSION OF VOICE, VIDEO, IMAGES, DATA AND INFORMATION; STREAMING OF DIGITAL MEDIA CONTENT FOR OTHERS VIA COMPUTER NETWORKS; PROVIDING E-MAIL SERVICES (U.S. CLS. 100, 101 AND 104).

INGA ERVIN, EXAMINING ATTORNEY

SN 85-497,863. DYNEX TECHNOLOGIES, CHELMSFORD, MA. FILED 12-16-2011.



THE MARK CONSISTS OF THE LETTER/NUMBER COMBINATION "M2", REPRESENTING "M" TO THE SECOND POWER, OR "M" SQUARED.

CLASS 9—ELECTRICAL AND SCIENTIFIC APPARATUS

FOR LABORATORY EQUIPMENT, NAMELY, AN AUTOMATED WORKSTATION FOR PROCESSING ASSAY PLATES AND PERFORMING CLINICAL AND DIAGNOSTIC ASSAYS, AND ACCOMPANYING COMPUTER SOFTWARE FOR OPERATING THE WORKSTATION, ALL FOR SCIENTIFIC RESEARCH, CLINICAL AND DIAGNOSTIC USE; LABORATORY EQUIPMENT, NAMELY, MICROSCOPE SLIDES, GLASS SLIDES, TRAYS AND PLATES FOR USE IN SCIENTIFIC RESEARCH (U.S. CLS. 21, 23, 26, 36 AND 38).

CLASS 10—MEDICAL APPARATUS

FOR MEDICAL DIAGNOSTIC APPARATUS, NAMELY, MICROSCOPE SLIDES, GLASS SLIDES, TRAYS AND PLATES FOR USE IN MEDICAL DIAGNOSIS, AND CLINICAL TESTING AND DIAGNOSIS, ALL FOR USE WITH MEDICAL AND PROCESS REAGENT KITS (U.S. CLS. 26, 39 AND 44).
 JAMES GRIFFIN, EXAMINING ATTORNEY

SN 85-497,893. METROPCS WIRELESS, INC., RICHARDSON, TX. FILED 12-16-2011.



THE COLOR(S) VIOLET, WHITE AND ORANGE IS/ARE CLAIMED AS A FEATURE OF THE MARK.
 THE MARK CONSISTS OF A LOWERCASE WHITE "M" TO THE LEFT OF AN ORANGE GREATER THAN SYMBOL IN A VIOLET BOX.

CLASS 9—ELECTRICAL AND SCIENTIFIC APPARATUS

FOR TELECOMMUNICATION HARDWARE, NAMELY, WIRELESS TELEPHONES, BATTERIES, CHARGERS, HANDS-FREE DEVICES AND WIRELESS HANDHELD COMMUNICATION DEVICES TO TRANSMIT, RECEIVE OR OTHERWISE ACCESS COMMUNICATIONS NETWORKS, FOR USE IN WIRELESS TELEPHONY AND IN THE PROVISION OF WIRELESS BROADBAND COMMUNICATION SERVICES FOR THE TRANSMISSION OF VOICE, VIDEO, IMAGES, DATA AND INFORMATION; COMPUTER APPLICATION SOFTWARE FOR MOBILE PHONES (U.S. CLS. 21, 23, 26, 36 AND 38).

CLASS 38—COMMUNICATION

FOR TELECOMMUNICATIONS SERVICES, NAMELY, WIRELESS TELEPHONY AND WIRELESS BROADBAND COMMUNICATIONS SERVICES FOR THE TRANSMISSION OF VOICE, VIDEO, IMAGES, DATA AND INFORMATION; STREAMING OF DIGITAL MEDIA CONTENT FOR OTHERS VIA COMPUTER NETWORKS; PROVIDING E-MAIL SERVICES (U.S. CLS. 100, 101 AND 104).
 INGA ERVIN, EXAMINING ATTORNEY

SN 85-498,836. SALVATION, LLC, TUSCON, AZ. FILED 12-19-2011.



THE MARK CONSISTS OF THE COMBINATION OF AN ANCHOR-LIKE DESIGN PARTIALLY-INTEGRATED INTO A HEART-SHAPED DESIGN CENTERED ON A STIPPLED CIRCULAR BACKGROUND.

CLASS 3—COSMETICS AND CLEANING PREPARATIONS

FOR COLOGNE, BODY LOTION, AFTERSHAVE (U.S. CLS. 1, 4, 6, 50, 51 AND 52).
 FIRST USE 12-1-2010; IN COMMERCE 12-1-2010.

CLASS 25—CLOTHING

FOR T-SHIRTS, SWEATSHIRTS, JACKETS, HOODED SWEATSHIRTS, SWEATERS, TANK TOPS (U.S. CLS. 22 AND 39).
 FIRST USE 12-1-2010; IN COMMERCE 12-1-2010.
 ELLEN BURNS, EXAMINING ATTORNEY

SN 85-500,214. TASTEFULLY SIMPLE, INC., ALEXANDRIA, MN. FILED 12-20-2011.

SN 85-503,970. NORMAN LOVE CONFECTIONS, INC., FORT MYERS, FL. FILED 12-27-2011.



EXPERIENCE A DELICIOUS LIFE

OWNER OF U.S. REG. NOS. 3,026,858, 3,141,215 AND OTHERS.

NO CLAIM IS MADE TO THE EXCLUSIVE RIGHT TO USE "ARTISAN GELATO", APART FROM THE MARK AS SHOWN.

THE NAME "NORMAN LOVE" IDENTIFIES A LIVING INDIVIDUAL WHOSE CONSENT IS OF RECORD.

THE MARK CONSISTS OF THE WORDS "ARTISAN GELATO", WITH TWO DOUBLE BLACK LINES ABOVE THE WORDS AND AN ICE CREAM CONE DESIGN CONSISTING OF A TRIANGULAR SHAPED LOWER HALF AND CIRCULAR AND SEMI-CIRCULAR SHAPED UPPER HALF IN BETWEEN EACH WORD, AND WITH "BY NORMAN LOVE" CENTERED UNDERNEATH WITH TWO DOUBLE BLACK LINES ON EACH SIDE OF THE WORDS.

THE MARK CONSISTS OF STANDARD CHARACTERS WITHOUT CLAIM TO ANY PARTICULAR FONT, STYLE, SIZE, OR COLOR.

CLASS 16—PAPER GOODS AND PRINTED MATTER

FOR PRINTED EDUCATIONAL MATERIALS IN THE FIELDS OF RECRUITMENT AND SALES (U.S. CLS. 2, 5, 22, 23, 29, 37, 38 AND 50).

CLASS 35—ADVERTISING AND BUSINESS

FOR PROVIDING ON-LINE INFORMATION IN THE FIELDS OF INDEPENDENT SALES REPRESENTATIVE RECRUITMENT, SALES METHODS, SALES MANAGEMENT AND SALES IMPROVEMENT (U.S. CLS. 100, 101 AND 102).

NATALIE POLZER, EXAMINING ATTORNEY

CLASS 30—STAPLE FOODS

FOR GELATO, ICE CREAM, GELATO SUNDAES, WAFFLES, CREPES, CAKES, ICE CREAM CAKES, COOKIES, ITALIAN COOKIES, COFFEE, COFFEE-BASED BEVERAGES, BAKERY DESSERTS, ICE CREAM DESSERTS, CANDY AND CHOCOLATES (U.S. CL. 46).

CLASS 35—ADVERTISING AND BUSINESS

FOR RETAIL STORE SERVICES FOR GELATO, ICE CREAM, GELATO SUNDAES, GELATO SHAKES, WAFFLES, CREPES, CAKES, ICE CREAM CAKES, COOKIES, ITALIAN COOKIES, COFFEE, COFFEE-BASED BEVERAGES, BAKERY DESSERTS, ICE CREAM DESSERTS, CANDY AND CHOCOLATES; PASTRY AND DESSERT SHOP SERVICES; RETAIL STORE SERVICES FEATURING ICE CREAM FOR CONSUMPTION OFF THE PREMISES (U.S. CLS. 100, 101 AND 102).

CLASS 43—HOTEL AND RESTAURANT SERVICES

FOR RESTAURANT SERVICES; ICE CREAM PARLORS; ICE CREAM SHOP SERVICES IN THE NATURE OF A RESTAURANT (U.S. CLS. 100 AND 101).

JAMES LOVELACE, EXAMINING ATTORNEY

SN 85-501,251. ABBOTT LABORATORIES, ABBOTT PARK, IL. FILED 12-21-2011.



OWNER OF U.S. REG. NOS. 1,475,612, 3,858,192 AND 3,862,056.

NO CLAIM IS MADE TO THE EXCLUSIVE RIGHT TO USE "CLEAR", APART FROM THE MARK AS SHOWN.

THE MARK CONSISTS OF THE STYLIZED WORD "PEDIASURE SIDEKICKS CLEAR".

CLASS 5—PHARMACEUTICALS

FOR LIQUID NUTRITIVE SUPPLEMENTS FOR HUMAN USE; NUTRITIONALLY FORTIFIED BEVERAGES AND POWDERS FOR MEAL REPLACEMENT (U.S. CLS. 6, 18, 44, 46, 51 AND 52).

CLASS 32—LIGHT BEVERAGES

FOR FRUIT DRINKS AND JUICES (U.S. CLS. 45, 46 AND 48).

TEJBIR SINGH, EXAMINING ATTORNEY

SN 85-504,511. SHIMANO INC., SAKAI CITY, OSAKA, JAPAN, FILED 12-27-2011.

CLICK'R

THE MARK CONSISTS OF STANDARD CHARACTERS WITHOUT CLAIM TO ANY PARTICULAR FONT, STYLE, SIZE, OR COLOR.

CLASS 12—VEHICLES

FOR BICYCLE PARTS, NAMELY, PEDALS; BICYCLE PEDALS (U.S. CLS. 19, 21, 23, 31, 35 AND 44).

CLASS 25—CLOTHING

FOR CYCLING SHOES; SHOES (U.S. CLS. 22 AND 39).

LEIGH LOWRY, EXAMINING ATTORNEY

SN 85-510,656. ALLRECIPES.COM, INC., SEATTLE, WA.
FILED 1-6-2012.

FOOD WISHES

THE MARK CONSISTS OF STANDARD CHARACTERS WITHOUT CLAIM TO ANY PARTICULAR FONT, STYLE, SIZE, OR COLOR.

NO CLAIM IS MADE TO THE EXCLUSIVE RIGHT TO USE "FOOD", APART FROM THE MARK AS SHOWN.

CLASS 41—EDUCATION AND ENTERTAINMENT

FOR ENTERTAINMENT SERVICES, NAMELY, PRESENTING AUDIO VISUAL WORKS ON THE SUBJECT OF COOKING AND FOOD OVER A GLOBAL COMPUTER NETWORK (U.S. CLS. 100, 101 AND 107).

FIRST USE 2-7-2007; IN COMMERCE 2-7-2007.

CLASS 43—HOTEL AND RESTAURANT SERVICES

FOR PROVIDING A WEBSITE ON GLOBAL COMPUTER NETWORKS FEATURING INFORMATION IN THE FIELD OF FOOD AND COOKING, INCLUDING RECIPES AND COOKING VIDEOS (U.S. CLS. 100 AND 101).

FIRST USE 2-7-2007; IN COMMERCE 2-7-2007.

JASON BLAIR, EXAMINING ATTORNEY

SN 85-511,268. METROPCS WIRELESS, INC., RICHARDSON, TX. FILED 1-8-2012.

CADA VEZ MAS VAN CON METRO

THE MARK CONSISTS OF STANDARD CHARACTERS WITHOUT CLAIM TO ANY PARTICULAR FONT, STYLE, SIZE, OR COLOR.

OWNER OF U.S. REG. NOS. 2,784,778, 2,865,446 AND OTHERS.

THE ENGLISH TRANSLATION OF "CADA VEZ MAS VAN CON METRO" IN THE MARK IS "EVERYBODY'S MOVING TO METRO".

CLASS 9—ELECTRICAL AND SCIENTIFIC APPARATUS

FOR TELECOMMUNICATION HARDWARE, NAMELY, WIRELESS TELEPHONES, BATTERIES, CHARGERS, HANDS-FREE DEVICES AND WIRELESS HANDHELD COMMUNICATION DEVICES TO TRANSMIT, RECEIVE OR OTHERWISE ACCESS COMMUNICATIONS NETWORKS, FOR USE IN WIRELESS TELEPHONY AND IN THE PROVISION OF WIRELESS BROADBAND COMMUNICATION SERVICES FOR THE TRANSMISSION OF VOICE, VIDEO, IMAGES, DATA AND INFORMATION; COMPUTER APPLICATION SOFTWARE FOR MOBILE PHONES (U.S. CLS. 21, 23, 26, 36 AND 38).

CLASS 38—COMMUNICATION

FOR TELECOMMUNICATIONS SERVICES, NAMELY, WIRELESS TELEPHONY AND WIRELESS BROADBAND COMMUNICATIONS SERVICES FOR THE TRANSMISSION OF VOICE, VIDEO, IMAGES, DATA AND INFORMATION; STREAMING OF DIGITAL MEDIA CONTENT FOR OTHERS VIA COMPUTER NETWORKS; PROVIDING E-MAIL SERVICES (U.S. CLS. 100, 101 AND 104).

INGA ERVIN, EXAMINING ATTORNEY

SN 85-511,527. THE UNIVERSITY OF NORTH CAROLINA AT CHAPEL HILL, CHAPEL HILL, NC. FILED 1-9-2012.



OWNER OF U.S. REG. NO. 1,255,590.

THE MARK CONSISTS OF THE INTERLOCKING LETTERS "N" AND "C" IN A STYLIZED FORMAT.

CLASS 16—PAPER GOODS AND PRINTED MATTER

FOR DECALS, NOTE CARDS, NOTEPADS, NOTE PAPER WITH ADHESIVE ON ONE SIDE FOR ATTACHMENT TO SURFACES (U.S. CLS. 2, 5, 22, 23, 29, 37, 38 AND 50).

FIRST USE 0-0-1982; IN COMMERCE 0-0-1982.

CLASS 21—HOUSEWARES AND GLASS

FOR DRINKING GLASSES, TRAVEL COFFEE MUGS, WINE GLASSES, PILSNER GLASSES, SHOT GLASSES, AND DISHWARE, NAMELY, CHIP AND DIP SET (U.S. CLS. 2, 13, 23, 29, 30, 33, 40 AND 50).

FIRST USE 0-0-1982; IN COMMERCE 0-0-1982.

CLASS 25—CLOTHING

FOR SHIRTS, TANK TOPS, SWEATSHIRTS, HEADBANDS, WRIST BANDS, SPORTS BRAS, SWEAT PANTS, CHEERLEADER OUTFITS, HEADWEAR, SHORTS, OUTERWEAR, HOCKEY JERSEYS, BASEBALL JERSEYS, FOOTBALL JERSEYS (U.S. CLS. 22 AND 39).

FIRST USE 0-0-1982; IN COMMERCE 0-0-1982.

CLASS 28—TOYS AND SPORTING GOODS

FOR GOLF BALLS, FOOTBALLS, GOLF HEAD COVERS, BASKETBALLS, SOCCER BALLS (U.S. CLS. 22, 23, 38 AND 50).

FIRST USE 0-0-1982; IN COMMERCE 0-0-1982.

JUSTINE D. PARKER, EXAMINING ATTORNEY

SN 85-511,549. CITIGROUP INC., NEW YORK, NY. FILED 1-9-2012.

SN 85-513,840. ORR CORPORATION, LOUISVILLE, KY. FILED 1-11-2012.

CITI PRESTIGE

PROTECTING PEOPLE, PROPERTY, AND THE ENVIRONMENT

THE MARK CONSISTS OF STANDARD CHARACTERS WITHOUT CLAIM TO ANY PARTICULAR FONT, STYLE, SIZE, OR COLOR.

THE MARK CONSISTS OF STANDARD CHARACTERS WITHOUT CLAIM TO ANY PARTICULAR FONT, STYLE, SIZE, OR COLOR.

CLASS 35—ADVERTISING AND BUSINESS

FOR PROMOTING THE SALE OF CREDIT CARD ACCOUNTS, AND THE GOODS AND SERVICES OF OTHERS, THROUGH CREDIT CARD CUSTOMER LOYALTY AND REWARD PROGRAMS (U.S. CLS. 100, 101 AND 102).

CLASS 35—ADVERTISING AND BUSINESS

FOR DISTRIBUTORSHIP SERVICES IN THE FIELD OF ALL FORMS OF SAFETY EQUIPMENT (U.S. CLS. 100, 101 AND 102).

CLASS 36—INSURANCE AND FINANCIAL

FOR CREDIT CARD SERVICES (U.S. CLS. 100, 101 AND 102).
RICHARD WHITE, EXAMINING ATTORNEY

CLASS 37—CONSTRUCTION AND REPAIR

FOR INSTALLATION, MAINTENANCE, AND REPAIR OF FIRE AND SMOKE DETECTION SYSTEMS AND EXPLOSION PROTECTION SYSTEMS (U.S. CLS. 100, 103 AND 106).
KATHY DE JONGE, EXAMINING ATTORNEY

SN 85-512,455. ALLRECIPES.COM, INC., SEATTLE, WA. FILED 1-10-2012.

SN 85-515,088. FRIED, FRANK, HARRIS, SHRIVER & JACOBSON LLP, NEW YORK, NY. FILED 1-12-2012.

FOOD WISHES

Fried Frank FINAlert

THE MARK CONSISTS OF STANDARD CHARACTERS WITHOUT CLAIM TO ANY PARTICULAR FONT, STYLE, SIZE, OR COLOR.

THE MARK CONSISTS OF STANDARD CHARACTERS WITHOUT CLAIM TO ANY PARTICULAR FONT, STYLE, SIZE, OR COLOR.

NO CLAIM IS MADE TO THE EXCLUSIVE RIGHT TO USE "FOOD", APART FROM THE MARK AS SHOWN.

OWNER OF U.S. REG. NOS. 2,430,826, 2,979,586 AND OTHERS.

CLASS 9—ELECTRICAL AND SCIENTIFIC APPARATUS

FOR COMPUTER APPLICATION SOFTWARE FOR MOBILE DEVICES AND INTERNET ENABLED TELEVISIONS, NAMELY, SOFTWARE FOR ACCESSING INFORMATION IN THE FIELD OF FOOD AND COOKING, INCLUDING RECIPES AND COOKING VIDEOS (U.S. CLS. 21, 23, 26, 36 AND 38).

CLASS 9—ELECTRICAL AND SCIENTIFIC APPARATUS

FOR DOWNLOADABLE ELECTRONIC MATERIALS AND PUBLICATIONS, NAMELY, NEWSLETTERS, EDUCATIONAL MATERIALS, AND PROFESSIONAL ARTICLES ALL CONCERNING LEGAL ISSUES (U.S. CLS. 21, 23, 26, 36 AND 38).

CLASS 41—EDUCATION AND ENTERTAINMENT

FOR PROVIDING ON-LINE PUBLICATIONS IN THE NATURE OF AN E-BOOK IN THE FIELD OF COOKING (U.S. CLS. 100, 101 AND 107).
JASON BLAIR, EXAMINING ATTORNEY

CLASS 16—PAPER GOODS AND PRINTED MATTER

FOR PRINTED MATERIALS AND PUBLICATIONS, NAMELY, NEWSLETTERS, EDUCATIONAL MATERIALS, AND PROFESSIONAL ARTICLES ALL CONCERNING LEGAL ISSUES (U.S. CLS. 2, 5, 22, 23, 29, 37, 38 AND 50).
ANDREA BUTLER, EXAMINING ATTORNEY

SN 85-517,136. JIGSAW MARKETING AND MEDIA LTD., BUCKINGHAMSHIRE, UNITED KINGDOM, FILED 1-16-2012.

CLASS 31—NATURAL AGRICULTURAL PRODUCTS

FOR SEEDS FOR FLOWERS, FRUIT AND VEGETABLES FOR HORTICULTURAL PURPOSES; SEEDLINGS, LIVE PLANTS AND SHRUBS; MULCHES (U.S. CLS. 1 AND 46).
KELLY BOULTON, EXAMINING ATTORNEY

CONTAINER MAGIC

SN 85-976,317. CONSTELLATION EUROPE LIMITED, GUILDFORD SURREY, UNITED KINGDOM, FILED 4-21-2011.

THE MARK CONSISTS OF STANDARD CHARACTERS WITHOUT CLAIM TO ANY PARTICULAR FONT, STYLE, SIZE, OR COLOR.

PRIORITY CLAIMED UNDER SEC. 44(D) ON ERP N CMNTY TM OFC APPLICATION NO. 010195857, FILED 8-15-2011, REG. NO. 010195857, DATED 12-27-2011, EXPIRES 8-15-2021.

NO CLAIM IS MADE TO THE EXCLUSIVE RIGHT TO USE "CONTAINER", APART FROM THE MARK AS SHOWN.

CLASS 1—CHEMICALS

FOR CHEMICALS AND CHEMICAL PREPARATIONS USED IN AGRICULTURE AND HORTICULTURE; EXCEPT FUNGICIDES, HERBICIDES, INSECTICIDES AND PARASITICIDES FERTILIZERS; MANURES; SOIL CONDITIONING PREPARATIONS; COMPOSTS; GROWING MEDIA FOR PLANTS; MINERAL FERTILIZING SUBSTANCES FOR USE IN GROWING PLANTS; GROWTH NUTRIENTS FOR PLANTS; PRODUCTS FOR USE IN GROWING PLANTS; NUTRIENTS FOR PLANTS; PLANT FEEDS; PLANT GROWTH REGULATING AGENTS; PLANTING ADDITIVES TO FACILITATE ROOTING; BIOLOGICAL AND BACTERIAL PREPARATIONS AND COMPOSITIONS FOR AIDING OR ENHANCING THE GROWTH OF PLANTS; PREPARATIONS FOR PROMOTING THE GROWTH OF PLANTS (U.S. CLS. 1, 5, 6, 10, 26 AND 46).

FRESHCASE

THE MARK CONSISTS OF STANDARD CHARACTERS WITHOUT CLAIM TO ANY PARTICULAR FONT, STYLE, SIZE, OR COLOR.

OWNER OF ERP N CMNTY TM OFC REG. NO. 008152341, DATED 11-12-2010, EXPIRES 3-12-2019.

CLASS 32—LIGHT BEVERAGES

FOR ALCOHOLIC BEERS; BEER; LAGER; NON-ALCOHOLIC COCKTAILS; PREPARATIONS FOR MAKING BEVERAGES, NAMELY, FRUIT DRINKS; NON-ALCOHOLIC FRUIT ESSENCES FOR MAKING BEVERAGES; TONIC WATER (U.S. CLS. 45, 46 AND 48).

CLASS 33—WINES AND SPIRITS

FOR ALCOHOLIC BEVERAGES EXCEPT BEER; ALCOPOPS; APERITIFS; CHAMPAGNE; HARD CIDERS; DRY SPARKLING WINE; PORT; RED WINE; SPIRITS; STILL WINES; STILL TABLE WINE; WHITE WINE; WINE (U.S. CLS. 47 AND 49).
JAMES LOVELACE, EXAMINING ATTORNEY

* * * * *

SECTION 2.— INTERNATIONAL CLASSIFICATION

The short titles associated below with the international class numbers are terms designed merely for quick identification and are not an official part of the international classification. The full names of international classes are given in section 6.1 of the trademark rules of practice.

The designation "U.S. Cl." appearing in this section refers to the U.S. class in effect prior to Sep. 1, 1973 rather than the international class which applies to applications filed on or after that date. For adoption of international classification see notice in the OFFICIAL GAZETTE of Jun. 26, 1973 (911 O.G. TM 210).

Application in one class

CLASS 1—CHEMICALS

SN 77-832,477. PHARMACHEM LABORATORIES, INC.,
KEARNY, NJ. FILED 9-22-2009.

QUIK D-SOLVE

THE MARK CONSISTS OF STANDARD CHARACTERS
WITHOUT CLAIM TO ANY PARTICULAR FONT, STYLE,
SIZE, OR COLOR.

FOR CHEMICALS FOR USE IN THE MANUFACTURE
OF PHARMACEUTICAL PRODUCTS (U.S. CLS. 1, 5, 6,
10, 26 AND 46).

DAVID I, EXAMINING ATTORNEY

CLASS 1—(Continued).

SN 79-105,213. BIOGRUND GMBH, FED REP GERMANY,
FILED 10-20-2011.

BonuCel

THE MARK CONSISTS OF STANDARD CHARACTERS
WITHOUT CLAIM TO ANY PARTICULAR FONT, STYLE,
SIZE, OR COLOR.

OWNER OF INTERNATIONAL REGISTRATION 1097191
DATED 10-20-2011, EXPIRES 10-20-2021.

FOR CHEMICALS USED IN INDUSTRY AND
SCIENCE, IN PARTICULAR AUXILIARY PREFORMING
CHEMICALS (U.S. CLS. 1, 5, 6, 10, 26 AND 46).

SHANNON TWOHIG, EXAMINING ATTORNEY

SN 79-104,686. DALIC, FRANCE, FILED 8-23-2011.

ZINIDAL

OWNER OF INTERNATIONAL REGISTRATION 0549020
DATED 1-17-1990, EXPIRES 1-17-2020.

FOR ELECTROLYTE SOLUTIONS FOR ELECTROLY-
TICALLY DEPOSITING A CORROSION-RESISTANT
COATING ON METAL (U.S. CLS. 1, 5, 6, 10, 26 AND 46).

ANNE FARRELL, EXAMINING ATTORNEY

SN 79-105,698. NOVOZYMES A/S., DENMARK, FILED 10-20-
2011.

TOLER-X

THE MARK CONSISTS OF STANDARD CHARACTERS
WITHOUT CLAIM TO ANY PARTICULAR FONT, STYLE,
SIZE, OR COLOR.

PRIORITY DATE OF 6-24-2011 IS CLAIMED.
OWNER OF INTERNATIONAL REGISTRATION 1098158
DATED 10-20-2011, EXPIRES 10-20-2021.

FOR MICROBES FOR ENVIRONMENTAL TOLER-
ANCE IN WASTEWATER SYSTEMS SUCH AS COLD
WEATHER ENVIRONMENTS (U.S. CLS. 1, 5, 6, 10, 26
AND 46).

MARCIE MILONE, EXAMINING ATTORNEY

CLASS 1—(Continued).

SN 85-171,681. MILLIKEN & COMPANY, SPARTANBURG, SC. FILED 11-8-2010.

OWNER OF U.S. REG. NOS. 2,274,504, 2,281,638 AND OTHERS.

THE MARK CONSISTS OF "MILLIKEN" IN CURSIVE WRITING.

SEC. 2(F).

FOR CHEMICAL ADDITIVES FOR USE IN THE MANUFACTURE OF A WIDE VARIETY OF GOODS; CHEMICALS FOR USE IN INDUSTRY; CHEMICALS AND CHEMICAL COMPOSITIONS, NAMELY, ANTI-STATIC AGENTS, FOR USE IN THE MANUFACTURE AND PROCESSING OF TEXTILES; EMULSIFIERS FOR USE IN THE MANUFACTURE AND PROCESSING OF COSMETICS, PAINT, INSECTICIDES, INDUSTRIAL CLEANERS, ORGANIC PIGMENTS, AND TEXTILES; SIZING COMPOUNDS FOR USE IN THE MANUFACTURE AND PROCESSING OF TEXTILES; SOIL RELEASE CHEMICALS FOR USE IN THE MANUFACTURE AND PROCESSING OF TEXTILES; CHEMICALS, NAMELY, SURFACE MODIFIERS FOR USE IN THE MANUFACTURE AND PROCESSING OF TEXTILES; CHEMICALS, NAMELY, DYEING AUXILIARIES; WETTING AGENTS; DISPERSANTS FOR GENERAL USE IN THE INDUSTRIAL ARTS; CHEMICALS FUNCTIONING AS NUCLEATING AGENTS FOR USE IN THE MANUFACTURE OF COATINGS, SUCH AS PAINTS AND VARNISHES, FILMS, MOLDING COMPOSITIONS, PLASTICS AND SYNTHETIC RESINS; CHEMICALS FUNCTIONING AS REINFORCING AGENTS FOR USE IN THE MANUFACTURE OF PLASTICS AND SYNTHETIC RESINS; CLARIFYING AGENTS FOR USE IN THE MANUFACTURE OF PLASTICS AND SYNTHETIC RESINS; ANTIMICROBIAL AGENTS FOR USE IN THE MANUFACTURE OF CLEANING PREPARATIONS, COATINGS FOR METALS, CERAMICS, TEXTILES, AND THERMOPLASTIC AND THERMOSET POLYMERS, COSMETICS, TWO-DIMENSIONAL AND THREE-DIMENSIONAL ARTICLES, NAMELY, SHEETS, FILMS, LAMINATES, FIBERS, FOAMS AND SHAPED PARTS MADE OF THERMOPLASTIC AND THERMOSET POLYMERS, INORGANIC MATRICES IN THE NATURE OF CONCRETE, CONDUCTIVE POWDERS AND DENTAL CEMENT, NATURAL AND SYNTHETIC POLYMERS FOR USE IN MEDICAL DEVICES, HOUSEWARES, NAMELY, BOWLS, BRUSHES, CUPS, CUTTING BOARDS, COLANDERS, COMBS, DINNERWARE, FOOD STORAGE CONTAINERS, GARBAGE CANS, LADLES, ROLLING PINS, RUBBER HOUSEHOLD GLOVES, SPONGES AND SPOONS, AUTOMOBILES, WATER FILTRATION, PIPES, TUBING AND DUCTWORK, TOYS, AND INDUSTRIAL PROCESSING EQUIPMENT, NAMELY, FOOD PROCESSING AND CONVEYING MACHINERY AND VESSELS; GELLING AGENTS FOR USE IN THE MANUFACTURE OF RESINS, COSMETICS, GLUE, ANTI-PERSPIRANT STICKS AND DEODORANT; CHEMICAL COMPOUNDS FOR FUNCTIONING AS CURING AGENTS FOR EPOXY RESINS; UV INHIBITORS FOR USE IN THE MANUFACTURE OF PLASTIC CONTAINERS; AND CHEMICALS FUNCTIONING AS CORROSION INHIBITORS FOR OILS (U.S. CLS. 1, 5, 6, 10, 26 AND 46).

LINDA ESTRADA, EXAMINING ATTORNEY

CLASS 1—(Continued).

SN 85-305,876. WILDCAT DISCOVERY TECHNOLOGIES, INC., SAN DIEGO, CA. FILED 4-27-2011.

WILDCAT DISCOVERY TECHNOLOGIES

THE MARK CONSISTS OF STANDARD CHARACTERS WITHOUT CLAIM TO ANY PARTICULAR FONT, STYLE, SIZE, OR COLOR.

NO CLAIM IS MADE TO THE EXCLUSIVE RIGHT TO USE "TECHNOLOGIES", APART FROM THE MARK AS SHOWN.

FOR CHEMICALS FOR USE IN INDUSTRIAL MANUFACTURING PROCESSES, NAMELY, CHEMICAL PREPARATIONS FOR USE IN THE INDUSTRIAL MANUFACTURE OF HYDROGEN STORAGE MATERIALS, THE INDUSTRIAL MANUFACTURE OF LITHIUM-ION BATTERIES, THE INDUSTRIAL MANUFACTURE OF INDUSTRIAL GAS SEPARATION MATERIALS, AND THE INDUSTRIAL MANUFACTURE OF CARBON CAPTURE MATERIALS; CHEMICAL AGENTS THAT ARE ELECTROCHEMICALLY ACTIVE MATERIALS FOR INCORPORATION INTO ELECTROCHEMICAL CELLS OR BATTERIES (U.S. CLS. 1, 5, 6, 10, 26 AND 46).

FIRST USE 10-13-2009; IN COMMERCE 10-13-2009.

ANNE E. GUSTASON, EXAMINING ATTORNEY

SN 85-305,897. WILDCAT DISCOVERY TECHNOLOGIES, INC., SAN DIEGO, CA. FILED 4-27-2011.



NO CLAIM IS MADE TO THE EXCLUSIVE RIGHT TO USE "TECHNOLOGIES", APART FROM THE MARK AS SHOWN.

THE COLOR(S) YELLOW AND BLACK IS/ARE CLAIMED AS A FEATURE OF THE MARK.

THE MARK CONSISTS OF A YELLOW CIRCLE AND THE WORDS "WILDCAT DISCOVERY TECHNOLOGIES" PARTIALLY COVER THE YELLOW CIRCLE WHERE THE WORD "WILDCAT" IS ABOVE THE WORD "DISCOVERY" AND WHERE THE WORD "DISCOVERY" IS ABOVE THE WORD "TECHNOLOGIES". THE WORDS "WILDCAT", "DISCOVERY", AND "TECHNOLOGIES" EACH BEGIN GENERALLY TO THE LEFT OF THE CENTER OF THE YELLOW CIRCLE AND EACH WORD ENDS BEYOND THE RIGHT EDGE OF THE CIRCLE AND ALL THE WORDING IS IN THE COLOR BLACK.

FOR CHEMICALS FOR USE IN INDUSTRIAL MANUFACTURING PROCESSES, NAMELY, CHEMICAL PREPARATIONS FOR USE IN THE INDUSTRIAL MANUFACTURE OF HYDROGEN STORAGE MATERIALS, THE INDUSTRIAL MANUFACTURE OF LITHIUM-ION BATTERIES, THE INDUSTRIAL MANUFACTURE OF INDUSTRIAL GAS SEPARATION MATERIALS, AND THE INDUSTRIAL MANUFACTURE OF CARBON CAPTURE MATERIALS; CHEMICAL AGENTS THAT ARE ELECTROCHEMICALLY ACTIVE MATERIALS FOR INCORPORATION INTO ELECTROCHEMICAL CELLS OR BATTERIES (U.S. CLS. 1, 5, 6, 10, 26 AND 46).

FIRST USE 10-13-2009; IN COMMERCE 10-13-2009.

ANNE E. GUSTASON, EXAMINING ATTORNEY

CLASS 1—(Continued).

SN 85-342,315. AGRASYST, SPOKANE, WA. FILED 6-9-2011.

G-MAX CA

THE MARK CONSISTS OF STANDARD CHARACTERS WITHOUT CLAIM TO ANY PARTICULAR FONT, STYLE, SIZE, OR COLOR.

NO CLAIM IS MADE TO THE EXCLUSIVE RIGHT TO USE "CA", APART FROM THE MARK AS SHOWN.

FOR ADJUVANTS FOR USE WITH PESTICIDES (U.S. CLS. 1, 5, 6, 10, 26 AND 46).

FIRST USE 4-29-2010; IN COMMERCE 4-29-2010.

MARK RADEMACHER, EXAMINING ATTORNEY

SN 85-342,349. AGRASYST, SPOKANE, WA. FILED 6-9-2011.

Load Out

THE MARK CONSISTS OF STANDARD CHARACTERS WITHOUT CLAIM TO ANY PARTICULAR FONT, STYLE, SIZE, OR COLOR.

NO CLAIM IS MADE TO THE EXCLUSIVE RIGHT TO USE "LOAD", APART FROM THE MARK AS SHOWN.

FOR ADJUVANTS FOR USE WITH PESTICIDES (U.S. CLS. 1, 5, 6, 10, 26 AND 46).

FIRST USE 6-6-2003; IN COMMERCE 9-1-2003.

MARK RADEMACHER, EXAMINING ATTORNEY

SN 85-372,441. GROUT SHIELD DISTRIBUTORS LLC, BAY SHORE, NY. FILED 7-15-2011.

**GROUT SHIELD GROUT
RESTORATION SYSTEM**

THE MARK CONSISTS OF STANDARD CHARACTERS WITHOUT CLAIM TO ANY PARTICULAR FONT, STYLE, SIZE, OR COLOR.

NO CLAIM IS MADE TO THE EXCLUSIVE RIGHT TO USE "GROUT" AND "RESTORATION SYSTEM", APART FROM THE MARK AS SHOWN.

FOR CHEMICAL COMPOUNDS FOR APPLICATION IN THE REPAIR OF EXISTING GROUT OR AFTER INSTALLATION OF THE GROUT (U.S. CLS. 1, 5, 6, 10, 26 AND 46).

FIRST USE 11-30-2006; IN COMMERCE 11-30-2006.

PAUL MORENO, EXAMINING ATTORNEY

CLASS 1—(Continued).

SN 85-372,606. INTERNATIONAL PETROLEUM PRODUCTS LIMITED, ESSEX, UNITED KINGDOM, FILED 7-15-2011.

DUZZ

THE MARK CONSISTS OF STANDARD CHARACTERS WITHOUT CLAIM TO ANY PARTICULAR FONT, STYLE, SIZE, OR COLOR.

OWNER OF UNITED KINGDOM REG. NO. 2475101, DATED 5-16-2008, EXPIRES 12-14-2017.

FOR CHEMICAL PREPARATIONS FOR USE IN THE BUILDING AND CONSTRUCTION INDUSTRY; CHEMICAL SUBSTANCES, NAMELY, CHEMICAL PREPARATIONS TO REMOVE OR DISSOLVE CONCRETE; ACIDIC CHEMICAL PREPARATIONS FOR USE AS CLEANERS FOR INDUSTRIAL PURPOSES FOR USE IN THE BUILDING AND CONSTRUCTION INDUSTRY; CHEMICAL PREPARATIONS FOR REMOVING CONCRETE, MORTAR, STUCCO AND CEMENT BASED ADHESIVES; CHEMICAL PREPARATIONS MADE FROM ACIDS FOR REMOVING OR DISSOLVING CONCRETE; CHEMICAL PREPARATIONS, NAMELY, SOLVENTS FOR CLEANING PURPOSES; CHEMICAL PREPARATIONS FOR USE AS SOLVENTS FOR DISSOLVING CONCRETE; CONCRETE DISSOLVING CHEMICAL PREPARATIONS; CHEMICAL PREPARATIONS, NAMELY, BIODEGRADABLE CLEANERS FOR USE IN THE BUILDING AND CONSTRUCTION INDUSTRY; UNSTICKING AND SEPARATING CHEMICAL PREPARATIONS (U.S. CLS. 1, 5, 6, 10, 26 AND 46).

JAMES MACFARLANE, EXAMINING ATTORNEY

SN 85-374,903. GAIA ENTERPRISES, INC., RICHBORO, PA. FILED S.R. 7-19-2011; AM. P.R. 1-11-2012.

**Safe
Paw** 

THE MARK CONSISTS OF WORD "SAFE" IS OVER TOP OF WORD "PAW" AND TO THE RIGHT OF WORD "PAW" IS A GRAPHIC OF A PAW PRINT WITH A CROSS WITHIN IT.

SEC. 2(F) AS TO "SAFE PAW".

FOR CHEMICAL PREPARATIONS FOR MELTING SNOW AND ICE (U.S. CLS. 1, 5, 6, 10, 26 AND 46).

FIRST USE 5-1-1995; IN COMMERCE 5-1-1995.

CURTIS FRENCH, EXAMINING ATTORNEY

CLASS 1—(Continued).

SN 85-400,385. ADDITECH, INC., HOUSTON, TX. FILED 8-17-2011.

**SUPER
MILEAGE
BOOSTER**

NO CLAIM IS MADE TO THE EXCLUSIVE RIGHT TO USE "SUPER MILEAGE BOOSTER", APART FROM THE MARK AS SHOWN.

THE MARK CONSISTS OF THE WORDS "SUPER MILEAGE BOOSTER", WITH THREE TRIANGLE SHAPES TO THE LEFT OF AND POINTING TO THE WORD "BOOSTER".

FOR DIESEL AND GASOLINE FUEL CHEMICAL ADDITIVES; DETERGENT ADDITIVES FOR FUELS (U.S. CLS. 1, 5, 6, 10, 26 AND 46).

FIRST USE 5-0-2011; IN COMMERCE 5-0-2011.

JENNIFER VASQUEZ, EXAMINING ATTORNEY

SN 85-416,580. PRODUCT ADDICTION, INC., LOS ANGELES, CA. FILED 9-7-2011.

Liquid Bathmat

THE MARK CONSISTS OF STANDARD CHARACTERS WITHOUT CLAIM TO ANY PARTICULAR FONT, STYLE, SIZE, OR COLOR.

NO CLAIM IS MADE TO THE EXCLUSIVE RIGHT TO USE "LIQUID", APART FROM THE MARK AS SHOWN.

FOR ANTI-SLIP CHEMICAL PREPARATIONS THAT ARE APPLIED TO HORIZONTAL SURFACES TO PREVENT SLIP AND FALL ACCIDENTS (U.S. CLS. 1, 5, 6, 10, 26 AND 46).

FIRST USE 12-27-2010; IN COMMERCE 12-27-2010.

RAMONA ORTIGA, EXAMINING ATTORNEY

SN 85-422,094. MONOSOL LLC, MERILLVILLE, IN. FILED 9-14-2011.

MONOFILM

THE MARK CONSISTS OF STANDARD CHARACTERS WITHOUT CLAIM TO ANY PARTICULAR FONT, STYLE, SIZE, OR COLOR.

FOR POLYVINYL ALCOHOL BASED FILM USED IN THE MANUFACTURING PROCESS OF SOLID SURFACE, COMPOSITE FABRICATION, PROSTHETIC FABRICATION AND MOLD RELEASE APPLICATIONS (U.S. CLS. 1, 5, 6, 10, 26 AND 46).

MATTHEW MCDOWELL, EXAMINING ATTORNEY

CLASS 1—(Continued).

SN 85-422,729. APPLIED POLYMER SYSTEMS, INC., WOODSTOCK, GA. FILED 9-14-2011.

POND ZINGER

THE MARK CONSISTS OF STANDARD CHARACTERS WITHOUT CLAIM TO ANY PARTICULAR FONT, STYLE, SIZE, OR COLOR.

NO CLAIM IS MADE TO THE EXCLUSIVE RIGHT TO USE "POND", APART FROM THE MARK AS SHOWN.

FOR CHEMICALS, NAMELY, SOIL SPECIFIC TAILORED POLYACRYLAMIDE CO-POLYMER FOR USE IN NUTRIENT CONTROL; AND SOIL SPECIFIC TAILORED POLYACRYLAMIDE CO-POLYMER BLENDS FOR WATER CLARIFICATION, ALL FOR USE IN SMALL PONDS AND LAKES (U.S. CLS. 1, 5, 6, 10, 26 AND 46).

ELLEN PERKINS, EXAMINING ATTORNEY

SN 85-422,734. APPLIED POLYMER SYSTEMS, INC., WOODSTOCK, GA. FILED 9-14-2011.

SOIL ZINGER

THE MARK CONSISTS OF STANDARD CHARACTERS WITHOUT CLAIM TO ANY PARTICULAR FONT, STYLE, SIZE, OR COLOR.

NO CLAIM IS MADE TO THE EXCLUSIVE RIGHT TO USE "SOIL", APART FROM THE MARK AS SHOWN.

FOR CHEMICALS, NAMELY, SOIL SPECIFIC TAILORED POLYACRYLAMIDE CO-POLYMER POWDER FOR EROSION AND SEDIMENT CONTROL, BINDING OF SEDIMENT, NUTRIENTS, SEED AND FERTILIZER, FOR INDUSTRIAL, COMMERCIAL, AND RESIDENTIAL USES (U.S. CLS. 1, 5, 6, 10, 26 AND 46).

ELLEN PERKINS, EXAMINING ATTORNEY

SN 85-422,758. APPLIED POLYMER SYSTEMS, INC., WOODSTOCK, GA. FILED 9-14-2011.

POOL ZINGER

THE MARK CONSISTS OF STANDARD CHARACTERS WITHOUT CLAIM TO ANY PARTICULAR FONT, STYLE, SIZE, OR COLOR.

NO CLAIM IS MADE TO THE EXCLUSIVE RIGHT TO USE "POOL", APART FROM THE MARK AS SHOWN.

FOR CHEMICALS, NAMELY, NUTRIENT AND ION SPECIFIC TAILORED POLYACRYLAMIDE CO-POLYMER FOR USE IN NUTRIENT CONTROL AND WATER CLARIFICATION IN POOLS (U.S. CLS. 1, 5, 6, 10, 26 AND 46).

ELLEN PERKINS, EXAMINING ATTORNEY

CLASS 1—(Continued).

SN 85-433,738. MICHAEL B KITCHEN, VIRGINIA BEACH, VA. FILED 9-28-2011.

Fresh Ink

THE MARK CONSISTS OF STANDARD CHARACTERS WITHOUT CLAIM TO ANY PARTICULAR FONT, STYLE, SIZE, OR COLOR.
NO CLAIM IS MADE TO THE EXCLUSIVE RIGHT TO USE "FRESH", APART FROM THE MARK AS SHOWN.
FOR PLANT EXTRACTS FOR USE IN THE MANUFACTURE OF CREAMS, LOTIONS AND COSMETIC PRODUCTS (U.S. CLS. 1, 5, 6, 10, 26 AND 46).
JEFFREY LOOK, EXAMINING ATTORNEY

SN 85-434,773. HOUSE AND GARDEN B.V., ALMERE, NETHERLANDS, FILED 9-28-2011.

TOP BOOSTER

THE MARK CONSISTS OF STANDARD CHARACTERS WITHOUT CLAIM TO ANY PARTICULAR FONT, STYLE, SIZE, OR COLOR.
FOR CHEMICAL AND BIOLOGICAL PRODUCTS FOR THE PROMOTION OF GROWTH AND BLOOMING IN PLANTS AND CROPS, NAMELY, FERTILIZERS FOR AGRICULTURAL, HORTICULTURAL, FORESTRY, DOMESTIC AND COMMERCIAL USE; CHEMICAL AND BIOLOGICAL SOIL ADDITIVES FOR AGRICULTURAL, HORTICULTURAL, FORESTRY, DOMESTIC AND COMMERCIAL USE (U.S. CLS. 1, 5, 6, 10, 26 AND 46).
FIRST USE 1-1-2006; IN COMMERCE 1-1-2006.
MICHAEL LITZAU, EXAMINING ATTORNEY

CLASS 1—(Continued).

SN 85-436,370. BROWN, RYAN WILLIAMS, SANTA BARBARA, CA. FILED 9-30-2011.

Prescription Potting Soil

THE MARK CONSISTS OF STANDARD CHARACTERS WITHOUT CLAIM TO ANY PARTICULAR FONT, STYLE, SIZE, OR COLOR.
NO CLAIM IS MADE TO THE EXCLUSIVE RIGHT TO USE "POTTING SOIL", APART FROM THE MARK AS SHOWN.
FOR FERTILISER FOR SOIL AND POTTING SOIL; FERTILISERS FOR SOIL AND POTTING SOIL; HORTICULTURAL POTTING MIXTURES; HORTICULTURAL PRODUCTS, NAMELY, SOIL AMENDMENTS THAT ARE INCORPORATED INTO OR ONTO A TURF, LAWN OR SOIL PROFILE FOR CREATING A HEALTH MEDIUM FOR INCREASED ROOT GROWTH AND/OR A SMOOTHER TURF OR LAWN SURFACE CUT OR APPEARANCE; NUTRITIVE ADDITIVE TO ENHANCE THE BIOLOGICAL ACTIVITY OF WATER, SOIL, SEEDS AND PLANTS FOR PURPOSES OF FERTILIZATION AND BIOREMEDIATION OF POLLUTANTS; ORGANIC SOIL ENHANCEMENT POWDERS AND PREPARATIONS; PLANTING SOIL; POTTING COMPOST; POTTING SOIL; SOIL ADDITIVES; SOIL AMENDMENTS; SOIL CONDITIONERS FOR HORTICULTURE USE; SOIL CONDITIONING PREPARATIONS; SOIL IMPROVING AGENTS; SOIL IMPROVING PREPARATIONS; SOIL WETTING AGENTS AND SOIL PENETRANTS (U.S. CLS. 1, 5, 6, 10, 26 AND 46).
JILL C. ALT, EXAMINING ATTORNEY

SN 85-441,597. CRAY VALLEY TECHNOLOGY USA, LLC, WILMINGTON, DE. FILED 10-7-2011.

DYMALINK

THE MARK CONSISTS OF STANDARD CHARACTERS WITHOUT CLAIM TO ANY PARTICULAR FONT, STYLE, SIZE, OR COLOR.
FOR MONOMERS FOR GENERAL INDUSTRIAL USE; INDUSTRIAL CHEMICALS, NAMELY, METALLIC COAGENTS; CHEMICALS FOR MANUFACTURING AND PROCESSING RUBBER, PLASTICS AND COATINGS (U.S. CLS. 1, 5, 6, 10, 26 AND 46).
GRETTA YAO, EXAMINING ATTORNEY

CLASS 1—(Continued).

SN 85-442,938. NATURE SCIENCES LLC, WASHOUGAL, WA. FILED 10-9-2011.



NO CLAIM IS MADE TO THE EXCLUSIVE RIGHT TO USE "PROTECTION", APART FROM THE MARK AS SHOWN.

THE COLOR(S) BLUE, WHITE, BURNT ORANGE, GREEN, BROWN, YELLOW, AND ORANGE IS/ARE CLAIMED AS A FEATURE OF THE MARK.

THE MARK CONSISTS OF THE WORDS "NEXT GENERATION PROTECTION" IN BLUE FONT ABOVE A SHIELD DESIGN WITH A BLUE BORDER AND WHITE TRIM. INSIDE THE SHIELD IS A FADED SUN DESIGN ON A BURNT ORANGE BACKGROUND, A FADED INSECT DESIGN ON A GREEN BACKGROUND, A WHITE AND BROWN LEAF DESIGN ON A YELLOW AND ORANGE BACKGROUND, AND A FADED SNOWFLAKE DESIGN ON A BLUE BACKGROUND. THE WORDS "NATURE SHIELD" APPEAR IN WHITE FONT ON A BLUE BANNER ACROSS THE MIDDLE OF THE SHIELD, AND THE WORDS "THE PROFESSIONAL'S CHOICE" APPEAR IN BLUE FONT BELOW THE SHIELD.

FOR CHEMICALS FOR USE IN AGRICULTURE, HORTICULTURE AND FORESTRY EXCEPT FUNGICIDES, HERBICIDES, INSECTICIDES AND PARASITICIDES (U.S. CLS. 1, 5, 6, 10, 26 AND 46).

FIRST USE 9-20-2010; IN COMMERCE 6-25-2011.

AMY KELLY, EXAMINING ATTORNEY

CLASS 1—(Continued).

SN 85-444,541. TEDIA COMPANY, INC., FAIRFIELD, OH. FILED 10-11-2011.



THE MARK CONSISTS OF A VISUAL REPRESENTATION OF A LABEL BEING PEELED OFF, WITH A SWIRL DESIGN IN THE TOP CENTER OF THE LABEL AND THE LETTERS "T2P2" UNDERNEATH THE DESIGN, ALL UNDERSCORED BY A LINE, AND IN SMALLER FONT, THE WEB SITE ADDRESS "WWW.T2-P2.COM".

FOR NON-AROMATIC HIGH-PURITY SOLVENTS FOR INDUSTRIAL AND COMMERCIAL USE; CHEMICAL REAGENTS FOR NON-MEDICAL PURPOSES (U.S. CLS. 1, 5, 6, 10, 26 AND 46).

MICHAEL WIENER, EXAMINING ATTORNEY

SN 85-445,048. ENZO LIFE SCIENCES, INC., FARMINGDALE, NY. FILED 10-12-2011.

CHEMILUM DE LYS

THE MARK CONSISTS OF STANDARD CHARACTERS WITHOUT CLAIM TO ANY PARTICULAR FONT, STYLE, SIZE, OR COLOR.

OWNER OF U.S. REG. NO. 3,721,060.

THE WORDING "DE LYS" HAS NO MEANING IN A FOREIGN LANGUAGE.

FOR KIT COMPRISED OF REAGENTS AND WELL PLATES FOR RESEARCH PURPOSES FOR USE IN DRUG DISCOVERY (U.S. CLS. 1, 5, 6, 10, 26 AND 46).

HENRY S. ZAK, EXAMINING ATTORNEY

CLASS 1—(Continued).

SN 85-445,496. BUCKMAN LABORATORIES INTERNATIONAL, INC., MEMPHIS, TN. FILED 10-12-2011.

MAXIMYZE

THE MARK CONSISTS OF STANDARD CHARACTERS WITHOUT CLAIM TO ANY PARTICULAR FONT, STYLE, SIZE, OR COLOR.

FOR ENZYME PREPARATIONS AND STABILIZED ENZYME PREPARATIONS FOR USE IN FIBER MODIFICATION, WOOD PROCESSING, PAPER MANUFACTURING, LEATHER PROCESSING, AND WATER TREATMENT (U.S. CLS. 1, 5, 6, 10, 26 AND 46).

FIRST USE 7-17-2009; IN COMMERCE 7-17-2009.
DEIRDRE ROBERTSON, EXAMINING ATTORNEY



SN 85-445,868. FRANK MILLER & SONS, INC., MOKENA, IL. FILED 10-12-2011.

SNOW COMMANDER

THE MARK CONSISTS OF STANDARD CHARACTERS WITHOUT CLAIM TO ANY PARTICULAR FONT, STYLE, SIZE, OR COLOR.

NO CLAIM IS MADE TO THE EXCLUSIVE RIGHT TO USE "SNOW", APART FROM THE MARK AS SHOWN.

FOR CHEMICAL PREPARATIONS FOR MELTING SNOW AND ICE (U.S. CLS. 1, 5, 6, 10, 26 AND 46).

ALAIN LAPTER, EXAMINING ATTORNEY



SN 85-446,751. UNITED SUPPLIERS, INC., ELDORA, IA. FILED 10-13-2011.

PAYOFF PLUS

THE MARK CONSISTS OF STANDARD CHARACTERS WITHOUT CLAIM TO ANY PARTICULAR FONT, STYLE, SIZE, OR COLOR.

OWNER OF U.S. REG. NO. 2,503,138.
FOR ADJUVANT FOR USE WITH POST EMERGENT HERBICIDE APPLICATIONS (U.S. CLS. 1, 5, 6, 10, 26 AND 46).

FIRST USE 6-1-2008; IN COMMERCE 6-1-2008.
COURTNEY ALVAREZ, EXAMINING ATTORNEY

CLASS 1—(Continued).

SN 85-446,756. MIDWEST RUBBER SERVICE & SUPPLY COMPANY INC., PLYMOUTH, MN. FILED 10-13-2011.

PRIMOTHANE

THE MARK CONSISTS OF STANDARD CHARACTERS WITHOUT CLAIM TO ANY PARTICULAR FONT, STYLE, SIZE, OR COLOR.

FOR POLYURETHANES (U.S. CLS. 1, 5, 6, 10, 26 AND 46).

ANDREA HACK, EXAMINING ATTORNEY



SN 85-447,136. FRANK MILLER & SONS, INC., MOKENA, IL. FILED 10-13-2011.

ICE CHASER

THE MARK CONSISTS OF STANDARD CHARACTERS WITHOUT CLAIM TO ANY PARTICULAR FONT, STYLE, SIZE, OR COLOR.

NO CLAIM IS MADE TO THE EXCLUSIVE RIGHT TO USE "ICE", APART FROM THE MARK AS SHOWN.

FOR CHEMICAL PREPARATIONS FOR MELTING SNOW AND ICE (U.S. CLS. 1, 5, 6, 10, 26 AND 46).

ALAIN LAPTER, EXAMINING ATTORNEY



SN 85-447,548. FRANK MILLER & SONS, INC., MOKENA, IL. FILED 10-14-2011.

SNO CHASER

THE MARK CONSISTS OF STANDARD CHARACTERS WITHOUT CLAIM TO ANY PARTICULAR FONT, STYLE, SIZE, OR COLOR.

NO CLAIM IS MADE TO THE EXCLUSIVE RIGHT TO USE "SNOW", APART FROM THE MARK AS SHOWN.

FOR CHEMICAL PREPARATIONS FOR MELTING SNOW AND ICE (U.S. CLS. 1, 5, 6, 10, 26 AND 46).

ALAIN LAPTER, EXAMINING ATTORNEY

CLASS 1—(Continued).

SN 85-447,795. STET ACQUISITION, INC., DBA WISEARTH AND WISEARTH ORGANICS, DALLAS, TX. FILED 10-14-2011.

FertiBOOST

THE MARK CONSISTS OF STANDARD CHARACTERS WITHOUT CLAIM TO ANY PARTICULAR FONT, STYLE, SIZE, OR COLOR.

FOR FERTILIZERS; FERTILIZERS FOR AGRICULTURAL USE; FERTILIZERS FOR DOMESTIC USE; NATURAL FERTILIZERS; ORGANIC SOIL ENHANCEMENT POWDERS AND PREPARATIONS (U.S. CLS. 1, 5, 6, 10, 26 AND 46).

DAVID C. REIHNER, EXAMINING ATTORNEY

SN 85-447,938. RECON TECHNOLOGIES LLC, GRAND RAPIDS, MI. FILED 10-14-2011.

ECActiv

THE MARK CONSISTS OF STANDARD CHARACTERS WITHOUT CLAIM TO ANY PARTICULAR FONT, STYLE, SIZE, OR COLOR.

FOR BACILLUS AND OTHER MICROBES SUSPENDED IN POWDERED OR LIQUID FORM FOR SANITATION, ODOR CONTROL AND WASTEWATER TREATMENT APPLICATIONS (U.S. CLS. 1, 5, 6, 10, 26 AND 46).

ELLEN B. AWRICH, EXAMINING ATTORNEY

SN 85-448,698. ACTIVE ORGANICS, INC., LEWISVILLE, TX. FILED 10-17-2011.

ACTISHELL

THE MARK CONSISTS OF STANDARD CHARACTERS WITHOUT CLAIM TO ANY PARTICULAR FONT, STYLE, SIZE, OR COLOR.

FOR CHEMICALS FOR USE IN THE MANUFACTURE OF COSMETIC AND PERSONAL CARE PRODUCTS (U.S. CLS. 1, 5, 6, 10, 26 AND 46).

FIRST USE 9-16-1992; IN COMMERCE 3-1-1998.

KATHLEEN LORENZO, EXAMINING ATTORNEY

CLASS 1—(Continued).

SN 85-449,972. PETTIT, MARSHALL W., HENDERSON, NV. FILED 10-18-2011.

Althiomite

THE MARK CONSISTS OF STANDARD CHARACTERS WITHOUT CLAIM TO ANY PARTICULAR FONT, STYLE, SIZE, OR COLOR.

FOR SOIL CONDITIONERS FOR AGRICULTURE USE (U.S. CLS. 1, 5, 6, 10, 26 AND 46).

FIRST USE 5-12-2011; IN COMMERCE 5-12-2011.

KELLEY WELLS, EXAMINING ATTORNEY

SN 85-450,054. ISP INVESTMENTS INC., WILMINGTON, DE. FILED 10-18-2011.

MELANOCARE

THE MARK CONSISTS OF STANDARD CHARACTERS WITHOUT CLAIM TO ANY PARTICULAR FONT, STYLE, SIZE, OR COLOR.

FOR CHEMICAL PRODUCTS FOR USE IN INDUSTRY AND SCIENCE, NAMELY, LINSEED SEED EXTRACT FOR USE IN THE MANUFACTURE OF PERSONAL CARE PREPARATIONS AND COSMETIC PREPARATIONS (U.S. CLS. 1, 5, 6, 10, 26 AND 46).

MICHAEL GAAFAR, EXAMINING ATTORNEY

SN 85-476,864. L. B. FOSTER COMPANY, PITTSBURGH, PA. FILED 11-18-2011.

ALLEVIATE

THE MARK CONSISTS OF STANDARD CHARACTERS WITHOUT CLAIM TO ANY PARTICULAR FONT, STYLE, SIZE, OR COLOR.

FOR CHEMICAL COMPOUND USED TO DECOMPOSE LEAVES AND OTHER ORGANIC MATERIAL FROM RAILWAY RAIL WITHOUT HARM TO THE ENVIRONMENT (U.S. CLS. 1, 5, 6, 10, 26 AND 46).

CAROLYN CATALDO, EXAMINING ATTORNEY

CLASS 1—(Continued).

SN 85-477,908. HELENA HOLDING COMPANY, WILMINGTON, DE. FILED 11-21-2011.

HYDRA-COAT

THE MARK CONSISTS OF STANDARD CHARACTERS WITHOUT CLAIM TO ANY PARTICULAR FONT, STYLE, SIZE, OR COLOR.

FOR A FERTILIZER ADDITIVE USED TO AID IN THE UPTAKE OF MICRONUTRIENTS FOR AGRICULTURAL, HORTICULTURAL AND COMMERCIAL USE (U.S. CLS. 1, 5, 6, 10, 26 AND 46).

DAVID YONTEF, EXAMINING ATTORNEY

SN 85-483,490. ACTIVE ORGANICS, INC., LEWISVILLE, TX. FILED 11-30-2011.

ACTISTING

THE MARK CONSISTS OF STANDARD CHARACTERS WITHOUT CLAIM TO ANY PARTICULAR FONT, STYLE, SIZE, OR COLOR.

FOR CHEMICALS FOR USE IN THE MANUFACTURE OF COSMETIC AND PERSONAL CARE PRODUCTS (U.S. CLS. 1, 5, 6, 10, 26 AND 46).

KATHLEEN LORENZO, EXAMINING ATTORNEY

SN 85-489,792. HELENA HOLDING COMPANY, WILMINGTON, DE. FILED 12-7-2011.

LIQUID CHISEL

THE MARK CONSISTS OF STANDARD CHARACTERS WITHOUT CLAIM TO ANY PARTICULAR FONT, STYLE, SIZE, OR COLOR.

NO CLAIM IS MADE TO THE EXCLUSIVE RIGHT TO USE "LIQUID", APART FROM THE MARK AS SHOWN.

FOR SOIL AMENDMENTS FOR USE IN AGRICULTURE (U.S. CLS. 1, 5, 6, 10, 26 AND 46).

DAVID YONTEF, EXAMINING ATTORNEY

CLASS 2—PAINTS

SN 79-103,912. SK KAKEN CO., LTD., OSAKA-FU 567-0056, JAPAN, FILED 9-7-2011.

MIRAC SAGAN NANO

THE MARK CONSISTS OF STANDARD CHARACTERS WITHOUT CLAIM TO ANY PARTICULAR FONT, STYLE, SIZE, OR COLOR.

PRIORITY DATE OF 8-17-2011 IS CLAIMED.

OWNER OF INTERNATIONAL REGISTRATION 1094188 DATED 9-7-2011, EXPIRES 9-7-2021.

OWNER OF U.S. REG. NO. 3,879,244.

NO CLAIM IS MADE TO THE EXCLUSIVE RIGHT TO USE "NANO", APART FROM THE MARK AS SHOWN.

FOR DECORATIVE COATINGS APPLIED BY SPRAY, ROLLER, BRUSH AND TROWEL; DECORATIVE COATINGS IN THE NATURE OF FINISHES AND RESURFACING COATINGS FOR USE ON CONCRETE, WOOD, MASONRY AND DRYWALL SURFACES; PAINTS; PIGMENTS; DYESTUFFS; PRINTING INKS; COLORS FOR DRAWING PICTURES, NAMELY, WATER-COLORS; ANTI-RUST GREASES; CANADA BALSAM, NAMELY, TURPENTINE; COPAL; SANDARAC; SHELLAC; PINE OIL FOR USE AS A WOOD PRESERVATIVE; PINE OIL FOR USE AS A PAINT THINNER; DAMMAR; MORDANT DYES; MASTICS, NAMELY, NATURAL RESINS; PINE GUM, NAMELY, NATURAL RESINS IN THE NATURE OF GUM EXTRACTS FROM PINE BARK; WOOD PRESERVATIVES (U.S. CLS. 6, 11 AND 16).

DARRYL SPRUILL, EXAMINING ATTORNEY

SN 79-104,068. SK KAKEN CO., LTD., JAPAN, FILED 9-7-2011.

MIRAC ART NANO

THE MARK CONSISTS OF STANDARD CHARACTERS WITHOUT CLAIM TO ANY PARTICULAR FONT, STYLE, SIZE, OR COLOR.

PRIORITY DATE OF 8-17-2011 IS CLAIMED.

OWNER OF INTERNATIONAL REGISTRATION 1094606 DATED 9-7-2011, EXPIRES 9-7-2021.

OWNER OF U.S. REG. NO. 3,879,244.

NO CLAIM IS MADE TO THE EXCLUSIVE RIGHT TO USE "ART NANO", APART FROM THE MARK AS SHOWN.

FOR DECORATIVE COATINGS APPLIED BY SPRAY, ROLLER, BRUSH AND TROWEL; DECORATIVE COATINGS IN THE NATURE OF FINISHES AND RESURFACING COATINGS FOR USE ON CONCRETE, WOOD, MASONRY AND DRYWALL SURFACES; PAINTS; PIGMENTS; DYESTUFFS; PRINTING INKS; COLORS FOR DRAWING PICTURES, NAMELY, WATER-COLORS; ANTI-RUST GREASES; CANADA BALSAM, NAMELY, TURPENTINE; COPAL; SANDARAC; SHELLAC; PINE OIL FOR USE AS A WOOD PRESERVATIVE; PINE OIL FOR USE AS A PAINT THINNER; DAMMAR; MORDANT DYES; MASTICS, NAMELY, NATURAL RESINS; PINE GUM, NAMELY, NATURAL RESINS IN THE NATURE OF GUM EXTRACTS FROM PINE BARK; WOOD PRESERVATIVES (U.S. CLS. 6, 11 AND 16).

DARRYL SPRUILL, EXAMINING ATTORNEY

CLASS 2—(Continued).

SN 79-104,069. SK KAKEN CO., LTD., OSAKA-FU 567-0056, JAPAN, FILED 9-7-2011.

MIRAC ELEGAN NANO

THE MARK CONSISTS OF STANDARD CHARACTERS WITHOUT CLAIM TO ANY PARTICULAR FONT, STYLE, SIZE, OR COLOR.

PRIORITY DATE OF 8-17-2011 IS CLAIMED.

OWNER OF INTERNATIONAL REGISTRATION 1094607 DATED 9-7-2011, EXPIRES 9-7-2021.

OWNER OF U.S. REG. NO. 3,879,244.

NO CLAIM IS MADE TO THE EXCLUSIVE RIGHT TO USE "NANO", APART FROM THE MARK AS SHOWN.

FOR DECORATIVE COATINGS APPLIED BY SPRAY, ROLLER, BRUSH AND TROWEL; DECORATIVE COATINGS IN THE NATURE OF FINISHES AND RESURFACING COATINGS FOR USE ON CONCRETE, WOOD, MASONRY AND DRYWALL SURFACES; PAINTS; PIGMENTS; DYESTUFFS; PRINTING INKS; COLORS FOR DRAWING PICTURES, NAMELY, WATER-COLORS; ANTI-RUST GREASES; CANADA BALSAM, NAMELY, TURPENTINE; COPAL; SANDARAC; SHELLAC; PINE OIL FOR USE AS A WOOD PRESERVATIVE; PINE OIL FOR USE AS A PAINT THINNER; DAMMAR; MORDANT DYES; MASTICS, NAMELY, NATURAL RESINS; PINE GUM, NAMELY, NATURAL RESINS IN THE NATURE OF GUM EXTRACTS FROM PINE BARK; WOOD PRESERVATIVES (U.S. CLS. 6, 11 AND 16).

DARRYL SPRUILL, EXAMINING ATTORNEY

CLASS 2—(Continued).

SN 85-172,157. MILLIKEN & COMPANY, SPARTANBURG, SC. FILED 11-9-2010.

OWNER OF U.S. REG. NOS. 2,274,504, 2,274,530 AND 2,281,638.

THE MARK CONSISTS OF "MILLIKEN" IN CURSIVE WRITING.

SEC. 2(F).

FOR COLORANTS; PIGMENTS; COLORANTS IN THE NATURE OF FUGITIVE TINTS; SPRAY PATTERN INDICATORS IN THE NATURE OF COLORANTS FOR APPLICATION OF FERTILIZERS, FUNGICIDES, HERBICIDES AND INSECTICIDES; DYES FOR BODIES OF WATER FOR AESTHETIC COLORATION ONLY (U.S. CLS. 6, 11 AND 16).

LINDA ESTRADA, EXAMINING ATTORNEY

SN 79-104,070. SK KAKEN CO., LTD., OSAKA-FU 567-0056, JAPAN, FILED 9-7-2011.

MIRAC BEAUTY NANO

THE MARK CONSISTS OF STANDARD CHARACTERS WITHOUT CLAIM TO ANY PARTICULAR FONT, STYLE, SIZE, OR COLOR.

PRIORITY DATE OF 8-17-2011 IS CLAIMED.

OWNER OF INTERNATIONAL REGISTRATION 1094608 DATED 9-7-2011, EXPIRES 9-7-2021.

OWNER OF U.S. REG. NO. 3,879,244.

NO CLAIM IS MADE TO THE EXCLUSIVE RIGHT TO USE "NANO", APART FROM THE MARK AS SHOWN.

FOR DECORATIVE COATINGS APPLIED BY SPRAY, ROLLER, BRUSH AND TROWEL; DECORATIVE COATINGS IN THE NATURE OF FINISHES AND RESURFACING COATINGS FOR USE ON CONCRETE, WOOD, MASONRY AND DRYWALL SURFACES; PAINTS; PIGMENTS; DYESTUFFS; PRINTING INKS; COLORS FOR DRAWING PICTURES, NAMELY, WATER-COLORS; ANTI-RUST GREASES; CANADA BALSAM, NAMELY, TURPENTINE; COPAL; SANDARAC; SHELLAC; PINE OIL FOR USE AS A WOOD PRESERVATIVE; PINE OIL FOR USE AS A PAINT THINNER; DAMMAR; MORDANT DYES; MASTICS, NAMELY, NATURAL RESINS; PINE GUM, NAMELY, NATURAL RESINS IN THE NATURE OF GUM EXTRACTS FROM PINE BARK; WOOD PRESERVATIVES (U.S. CLS. 6, 11 AND 16).

DARRYL SPRUILL, EXAMINING ATTORNEY

SN 85-272,444. PREMIER DEALER SERVICES, INC., SAN DIEGO, CA. FILED 3-21-2011.

Premier Defense Leather & Vinyl Protection

THE MARK CONSISTS OF STANDARD CHARACTERS WITHOUT CLAIM TO ANY PARTICULAR FONT, STYLE, SIZE, OR COLOR.

NO CLAIM IS MADE TO THE EXCLUSIVE RIGHT TO USE "LEATHER & VINYL PROTECTION", APART FROM THE MARK AS SHOWN.

FOR PROTECTIVE COATINGS IN THE NATURE OF A SEALANT TO PRESERVE, PROTECT AND ADD TO THE LIFE EXPECTANCY OF INTERIOR AUTOMOBILE SURFACES, NAMELY, LEATHER AND VINYL SURFACES SUCH AS SEATS, INTERIOR DOORS, AND DASHBOARDS (U.S. CLS. 6, 11 AND 16).

HEATHER THOMPSON, EXAMINING ATTORNEY

CLASS 2—(Continued).

SN 85-322,294. DELTA CREATIVE, INC., CITY OF INDUSTRY, CA. FILED 5-16-2011.



The logo for "Air-Dry PermEnamel" features the words "Air-Dry" in a blue, sans-serif font above the word "PermEnamel" in a red, serif font. The "E" in "PermEnamel" is significantly larger than the other letters.

NO CLAIM IS MADE TO THE EXCLUSIVE RIGHT TO USE "AIR-DRY", APART FROM THE MARK AS SHOWN.

THE COLOR(S) BLUE AND RED IS/ARE CLAIMED AS A FEATURE OF THE MARK.

THE MARK CONSISTS OF THE WORDING "AIR-DRY" IN BLUE AND THE LARGER WORDING "PERMENAMEL" IN RED UNDERNEATH.

FOR PAINT FOR ARTS AND CRAFTS FOR GLASS, CERAMIC, AND TILE APPLICATIONS; PAINTS (U.S. CLS. 6, 11 AND 16).

FIRST USE 12-0-1996; IN COMMERCE 12-0-1996.
ANNE E. GUSTASON, EXAMINING ATTORNEY

SN 85-398,077. MASTER COATING TECHNOLOGIES, LLC, EAGAN, MN. FILED 8-15-2011.

SCRUBTOUGH

THE MARK CONSISTS OF STANDARD CHARACTERS WITHOUT CLAIM TO ANY PARTICULAR FONT, STYLE, SIZE, OR COLOR.

FOR PAINTS (U.S. CLS. 6, 11 AND 16).

FIRST USE 12-31-1998; IN COMMERCE 12-31-1998.
HENRY S. ZAK, EXAMINING ATTORNEY

SN 85-445,806. GUPTA,LAXMI C., LOS ALAMITOS, CA. FILED 10-12-2011.

POXY PRIME

THE MARK CONSISTS OF STANDARD CHARACTERS WITHOUT CLAIM TO ANY PARTICULAR FONT, STYLE, SIZE, OR COLOR.

NO CLAIM IS MADE TO THE EXCLUSIVE RIGHT TO USE "PRIME", APART FROM THE MARK AS SHOWN.

FOR CLEAR AND PIGMENTED COATINGS USED IN THE NATURE OF PAINT (U.S. CLS. 6, 11 AND 16).

FIRST USE 9-19-2011; IN COMMERCE 9-26-2011.
CHRISTINE MARTIN, EXAMINING ATTORNEY

CLASS 2—(Continued).

SN 85-472,780. BASF SE, LUDWIGSHAFEN AM RHEIN, FED REP GERMANY, FILED 11-15-2011.

ORACET

THE MARK CONSISTS OF STANDARD CHARACTERS WITHOUT CLAIM TO ANY PARTICULAR FONT, STYLE, SIZE, OR COLOR.

FOR POLYMER SOLUBLE COLORANTS AND DYES FOR THE COLORATION AND FUNCTIONALIZATION OF THERMOPLASTICS AND THERMOSET RESINS FOR PLASTICS AND SYNTHETIC FIBER APPLICATIONS (U.S. CLS. 6, 11 AND 16).

FIRST USE 9-19-1946; IN COMMERCE 9-19-1946.
ROBERT STRUCK, EXAMINING ATTORNEY

SN 85-485,157. BONA AB, SE-200 21 MALMÖ, SWEDEN, FILED 12-1-2011.

BONA PROFESSIONAL GRADE

THE MARK CONSISTS OF STANDARD CHARACTERS WITHOUT CLAIM TO ANY PARTICULAR FONT, STYLE, SIZE, OR COLOR.

OWNER OF U.S. REG. NOS. 1,640,991, 3,925,024 AND OTHERS.

NO CLAIM IS MADE TO THE EXCLUSIVE RIGHT TO USE "PROFESSIONAL GRADE", APART FROM THE MARK AS SHOWN.

FOR FURNITURE FINISH AND ALL PURPOSE FINISH, NAMELY COATINGS USED FOR FINISHING FURNITURE, WOOD CABINETS, DOOR AND WINDOW MOLDINGS AND OTHER INTERIOR WOODWORK (U.S. CLS. 6, 11 AND 16).

JAMES STEIN, EXAMINING ATTORNEY

CLASS 3—COSMETICS AND CLEANING PREPARATIONS

SN 76-707,704. JASON & JEAN PRODUCTS INC., CORONA, NY. FILED 5-23-2011.

LANELL HAIR BONDING GLUE

THE MARK CONSISTS OF STANDARD CHARACTERS WITHOUT CLAIM TO ANY PARTICULAR FONT, STYLE, SIZE, OR COLOR.

OWNER OF U.S. REG. NOS. 3,941,003, 3,963,911 AND OTHERS.

NO CLAIM IS MADE TO THE EXCLUSIVE RIGHT TO USE "HAIR BONDING GLUE", APART FROM THE MARK AS SHOWN.

FOR HAIR SHAMPOO, HAIR CONDITIONER, HAIR SPRAY, ADHESIVE FOR USE WITH HAIR PIECES AND HAIR BOND REMOVER FOR HAIR (U.S. CLS. 1, 4, 6, 50, 51 AND 52).

FIRST USE 3-6-2001; IN COMMERCE 3-6-2001.
RON FAIRBANKS, EXAMINING ATTORNEY

SN 76-707,705. JASON & JEAN PRODUCTS INC., CORONA, NY. FILED 5-23-2011.

LANELL SUPER HAIR WEAVING BOND

THE MARK CONSISTS OF STANDARD CHARACTERS WITHOUT CLAIM TO ANY PARTICULAR FONT, STYLE, SIZE, OR COLOR.

OWNER OF U.S. REG. NOS. 3,941,003, 3,963,911 AND OTHERS.

NO CLAIM IS MADE TO THE EXCLUSIVE RIGHT TO USE "SUPER HAIR WEAVING BOND", APART FROM THE MARK AS SHOWN.

FOR HAIR SHAMPOO, HAIR CONDITIONER, HAIR SPRAY, ADHESIVE FOR USE WITH HAIR PIECES AND HAIR BOND REMOVER FOR HAIR (U.S. CLS. 1, 4, 6, 50, 51 AND 52).

FIRST USE 3-6-2001; IN COMMERCE 3-6-2001.
RON FAIRBANKS, EXAMINING ATTORNEY

SN 76-708,426. KAO KABUSHIKI KAISHA, TOKYO 103-8210, JAPAN, FILED 7-20-2011.

Koishimaru

THERE IS NO ENGLISH TRANSLATION FOR "KOISHIMARU".

FOR COSMETIC INGREDIENT USED IN THE MANUFACTURE OF NON-MEDICATED SKIN CARE PREPARATIONS (U.S. CLS. 1, 4, 6, 50, 51 AND 52).

KELLY TRUSILO, EXAMINING ATTORNEY

CLASS 3—(Continued).

SN 76-708,436. THE PERFUMER'S WORKSHOP INTERNATIONAL, LTD., NEW YORK, NY. FILED 7-21-2011.



OWNER OF U.S. REG. NOS. 2,209,156 AND 3,750,982.
THE COLOR(S) WHITE, BLACK AND RED IS/ARE CLAIMED AS A FEATURE OF THE MARK.

THE MARK CONSISTS OF A WHITE RECTANGLE WITH THE WORD "ZIPPED" IN WHITE AND OUTLINED IN BLACK. BELOW THE WORD "ZIPPED" IS A RED RECTANGLE WITH THE WORDING "REBEL" IN WHITE. TO THE RIGHT OF THE WHITE RECTANGLE IS A BLACK ZIPPER WITH A RED SEMI-CIRCLE AND A WHITE INVERTED TRIANGLE INSIDE THE SEMI-CIRCLE AT THE TOP OF THE ZIPPER.

FOR EAU DE TOILETTE, PERFUME AND COLOGNE (U.S. CLS. 1, 4, 6, 50, 51 AND 52).

FIRST USE 7-19-2011; IN COMMERCE 7-19-2011.
ESTHER A. BORSUK, EXAMINING ATTORNEY

SN 76-708,437. THE PERFUMER'S WORKSHOP INTERNATIONAL, LTD., NEW YORK, NY. FILED 7-21-2011.

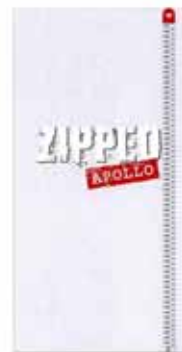

OWNER OF U.S. REG. NOS. 2,209,156 AND 3,750,982.
THE COLOR(S) BLACK, WHITE, AND RED IS/ARE CLAIMED AS A FEATURE OF THE MARK.

THE MARK CONSISTS OF A WHITE RECTANGLE WITH THE WORD "ZIPPED" IN WHITE AND OUTLINED IN BLACK. BELOW THE WORD "ZIPPED" IS A RED RECTANGLE WITH THE WORDING "APOLLO" IN WHITE. TO THE RIGHT OF THE WHITE RECTANGLE IS A BLACK ZIPPER WITH A RED SEMI-CIRCLE AND A WHITE INVERTED TRIANGLE INSIDE THE SEMI-CIRCLE AT THE TOP OF THE ZIPPER.

FOR EAU DE TOILETTE, PERFUME AND COLOGNE (U.S. CLS. 1, 4, 6, 50, 51 AND 52).

FIRST USE 7-19-2011; IN COMMERCE 7-19-2011.
ESTHER A. BORSUK, EXAMINING ATTORNEY

CLASS 3—(Continued).

SN 76-708,438. THE PERFUMER'S WORKSHOP INTERNATIONAL, LTD., NEW YORK, NY. FILED 7-21-2011.



OWNER OF U.S. REG. NOS. 2,209,156 AND 3,750,982.
THE COLOR(S) WHITE, BLACK AND RED IS/ARE CLAIMED AS A FEATURE OF THE MARK.
THE MARK CONSISTS OF A WHITE RECTANGLE WITH THE WORD "ZIPPED" IN WHITE AND OUTLINED IN BLACK. BELOW THE WORD "ZIPPED" IS A RED RECTANGLE WITH THE WORDING "SOHO NOIR" IN WHITE. TO THE RIGHT OF THE WHITE RECTANGLE IS A BLACK ZIPPER WITH A RED SEMI-CIRCLE AND A WHITE INVERTED TRIANGLE INSIDE THE SEMI-CIRCLE AT THE TOP OF THE ZIPPER.

FOR EAU DE TOILETTE, PERFUME AND COLOGNE (U.S. CLS. 1, 4, 6, 50, 51 AND 52).

FIRST USE 7-19-2011; IN COMMERCE 7-19-2011.
ESTHER A. BORSUK, EXAMINING ATTORNEY

SN 76-708,439. THE PERFUMER'S WORKSHOP INTERNATIONAL, LTD., NEW YORK, NY. FILED 7-21-2011.



OWNER OF U.S. REG. NOS. 2,209,156 AND 3,750,982.
THE COLOR(S) WHITE, BLACK AND RED IS/ARE CLAIMED AS A FEATURE OF THE MARK.

THE MARK CONSISTS OF A WHITE RECTANGLE WITH THE WORD "ZIPPED" IN WHITE AND OUTLINED IN BLACK. BELOW THE WORD "ZIPPED" IS A RED RECTANGLE WITH THE WORDING "PREMIER" IN WHITE. TO THE RIGHT OF THE WHITE RECTANGLE IS A BLACK ZIPPER WITH A RED SEMI-CIRCLE AND A WHITE INVERTED TRIANGLE INSIDE THE SEMI-CIRCLE AT THE TOP OF THE ZIPPER.

FOR EAU DE TOILETTE, PERFUME AND COLOGNE (U.S. CLS. 1, 4, 6, 50, 51 AND 52).

FIRST USE 7-19-2011; IN COMMERCE 7-19-2011.
ESTHER A. BORSUK, EXAMINING ATTORNEY

CLASS 3—(Continued).

SN 77-813,747. RASIKLAL RADIA, TA AARGEE NOVELTIES, LONDON, UNITED KINGDOM, AND INDIRA RADIA, TA AARGEE NOVELTIES, LONDON, UNITED KINGDOM, AND NIMESH RADIA, TA AARGEE NOVELTIES, LONDON, UNITED KINGDOM, AND JAYMINI RADIA, TA AARGEE NOVELTIES, LONDON, UNITED KINGDOM, FILED 8-27-2009.



OWNER OF UNITED KINGDOM REG. NO. 2380293, DATED 12-13-2004, EXPIRES 12-12-2014.

THE COLOR(S) BLACK AND BLUE IS/ARE CLAIMED AS A FEATURE OF THE MARK.

THE MARK CONSISTS OF THE STYLIZED WORDING "STAMFORD INC." WHICH APPEARS IN BLACK COLOR EXCEPT THE LETTER "F" THEREOF WHICH IS IN BLUE. FOR INCENSE IN THE FORM OF STICKS, COILS AND POWDERS (U.S. CLS. 1, 4, 6, 50, 51 AND 52).

FIRST USE 5-12-2004; IN COMMERCE 5-12-2004.
DAWN HAN, EXAMINING ATTORNEY

SN 77-843,769. RESTING IN THE RIVER, LLC, SANTA FE, NM. FILED 10-7-2009.

INTENS-SALVE

THE MARK CONSISTS OF STANDARD CHARACTERS WITHOUT CLAIM TO ANY PARTICULAR FONT, STYLE, SIZE, OR COLOR.

FOR COSMETIC PREPARATIONS FOR SKIN RENEWAL (U.S. CLS. 1, 4, 6, 50, 51 AND 52).

FIRST USE 8-1-2005; IN COMMERCE 9-29-2005.
JANICE L. MCMORROW, EXAMINING ATTORNEY

CLASS 3—(Continued).

SN 78-466,266. AT LAST NATURALS, INC., VALHALLA, NY. FILED 8-12-2004.

**LOOK GOOD, GET
LUCKY!**

THE MARK CONSISTS OF STANDARD CHARACTERS WITHOUT CLAIM TO ANY PARTICULAR FONT, STYLE, SIZE, OR COLOR.

FOR HAIR CARE PREPARATIONS, NAMELY, SHAMPOO, CONDITIONER, HAIR SPRAY, AND STYLING GEL; SKIN CARE PREPARATIONS, NAMELY, BODY CREAM, HAND CREAM, SKIN LOTION, BODY LOTION, FACIAL LOTION, FACIAL SCRUBS, MOISTURIZERS, SOAP, SHOWER GEL, BATH GEL, BATH OIL, AFTER-SHAVE LOTION, SHAVING CREAM, AND BABY POWDER; SUNTAN LOTION; TOOTHPASTE; MOUTHWASH; COLOGNES (U.S. CLS. 1, 4, 6, 50, 51 AND 52).

HENRY S. ZAK, EXAMINING ATTORNEY

SN 78-798,103. ASHLAND LICENSING AND INTELLECTUAL PROPERTY LLC, DUBLIN, OH. FILED 1-24-2006.

NANOCLEAN

THE MARK CONSISTS OF STANDARD CHARACTERS WITHOUT CLAIM TO ANY PARTICULAR FONT, STYLE, SIZE, OR COLOR.

FOR AUTOMOBILE WAXES AND POLISHES, WHEEL CLEANERS AND CLEANERS FOR USE ON PAINTED CAR SURFACES (U.S. CLS. 1, 4, 6, 50, 51 AND 52).

EDWARD NELSON, EXAMINING ATTORNEY

SN 79-088,810. NORDBEAUTY S.R.L., ITALY, FILED 8-4-2010.

LIFT VITAL

PRIORITY DATE OF 6-17-2010 IS CLAIMED.

OWNER OF INTERNATIONAL REGISTRATION 1055157 DATED 8-4-2010, EXPIRES 8-4-2020.

FOR DETERGENTS FOR COSMETIC USE; FACE, NECK AND BODY LOTIONS; COSMETIC CREAMS; MASSAGE CREAMS FOR COSMETIC TREATMENT FOR HUMANS; COSMETIC MASKS; COSMETICS IN THE FORM OF SERUMS FOR THE FACE, NECK AND BODY; ALGAE FOR COSMETIC USE (U.S. CLS. 1, 4, 6, 50, 51 AND 52).

LEIGH LOWRY, EXAMINING ATTORNEY

CLASS 3—(Continued).

SN 79-096,962. I.D. BEAUTY INTERNATIONAL DISTRIBUTION LIMITED, UNITED KINGDOM, FILED 4-5-2011.

FRUIT FOREVER

THE MARK CONSISTS OF STANDARD CHARACTERS WITHOUT CLAIM TO ANY PARTICULAR FONT, STYLE, SIZE, OR COLOR.

OWNER OF INTERNATIONAL REGISTRATION 1075997 DATED 4-5-2011, EXPIRES 4-5-2021.

NO CLAIM IS MADE TO THE EXCLUSIVE RIGHT TO USE "FRUIT", APART FROM THE MARK AS SHOWN.

FOR MAKE-UP REMOVING PREPARATIONS; COSMETICS, NAMELY, TONERS (U.S. CLS. 1, 4, 6, 50, 51 AND 52).

SHAUNIA CARLYLE, EXAMINING ATTORNEY

SN 79-097,445. ZIAJA LTD ZAKLAD PRODUKCJI LEKÓW SPÓŁKA Z O.O., PL-80-298 GDANSK, POLAND, FILED 9-6-2010.

bveco

OWNER OF INTERNATIONAL REGISTRATION 1077327 DATED 9-6-2010, EXPIRES 9-6-2020.

THE MARK CONSISTS OF THE LETTERS "B" AND "ECO" SEPARATED BY A STYLIZED FLOWER BETWEEN "B" AND "ECO".

FOR COSMETICS; WASHING PREPARATIONS, NAMELY, BODY WASH FOR HUMANS, LIQUID SOAPS FOR HAND, FACE AND BODY, SOAPS FOR BODY CARE; HAIR CARE PREPARATIONS, SKIN CARE PREPARATIONS; INTIMATE HYGIENE PREPARATIONS, NAMELY, NON-MEDICATED FEMININE HYGIENE WASH AND FEMININE HYGIENE CLEANSING TOWELETES; PERFUMERY, ETHEREAL OILS; DENTIFRICES AND PREPARATIONS FOR CLEANING DENTURES, MOUTHWASHES; TOILETRIES, NAMELY, BODY DEODORANTS AND DEODORANTS FOR PERSONAL USE; NON-MEDICATED TOILETRIES (U.S. CLS. 1, 4, 6, 50, 51 AND 52).

KATHLEEN M. VANSTON, EXAMINING ATTORNEY

CLASS 3—(Continued).

SN 79-100,298. C.F.E.B. SISLEY, FRANCE, FILED 6-29-2011.



PRIORITY DATE OF 2-15-2011 IS CLAIMED.
OWNER OF INTERNATIONAL REGISTRATION 1084894
DATED 6-29-2011, EXPIRES 6-29-2021.
OWNER OF U.S. REG. NOS. 1,187,304, 1,219,617 AND
3,035,881.

THE COLOR(S) WHITE, BLACK, YELLOW AND GRAY
IS/ARE CLAIMED AS A FEATURE OF THE MARK.

THE MARK CONSISTS OF THE FOLLOWING: THE
COLOR WHITE IS IN THE BACKGROUND OF THE
SQUARE, AND IN THE WORDING "SISLEY", THE COLOR
BLACK IS IN THE WORDING "EAU D'IKAR" AND IN THE
DESIGN OF THE DOTS, THE COLOR YELLOW IS IN THE
DESIGN OF THE DOTS IN THE BACKGROUND, AND THE
COLOR GRAY IS IN THE BACKGROUND OF THE REC-
TANGLE.

THE ENGLISH TRANSLATION OF "EAU D'IKAR" IN
THE MARK IS "WATER OF IKAR".

FOR SOAP, PERFUMERY, ESSENTIAL OILS, COS-
METICS, HAIR LOTIONS, DENTIFRICES (U.S. CLS. 1,
4, 6, 50, 51 AND 52).

ANNE E. GUSTASON, EXAMINING ATTORNEY

SN 79-101,000. ALLONGE CORP., REPUBLIC OF KOREA,
FILED 12-8-2010.

샤샤킴
Sha Sha Kim

OWNER OF INTERNATIONAL REGISTRATION 1086642
DATED 12-8-2010, EXPIRES 12-8-2020.

THE WORDING "SHA SHA KIM" HAS NO MEANING IN
A FOREIGN LANGUAGE.

THE transliteration of the non-Latin char-
acters in the mark is "SHA SHA KIM".

FOR NAIL ENAMEL REMOVERS; AFTER SUN
CREAMS; AFTER-SHAVE CREAMS; AFTER-SHAVE
EMULSIONS; AFTER-SHAVE LOTIONS; ALMOND
MILK FOR COSMETIC PURPOSES; ANTIPERSPIRANTS;
ANTIPERSPIRANTS FOR PERSONAL USE; ASTRIN-
GENTS FOR COSMETIC PURPOSES; BABY HAIR CON-
DITIONER; BABY OIL; BATH BEADS; BATH FOAM;
BATH GELS; BATH LOTIONS; BATH OIL; BATH OILS
FOR HAIR CARE; BATH SALTS; COSMETIC PREPARA-
TIONS FOR BATHS; BEAUTY CREAMS; BLUSH PEN-
CILS; BLUSHER; BODY CREAMS; BODY LOTIONS;
BODY MILKS; BODY OILS; CLEANSING MILK;
CLEANSING MILK FOR TOILET PURPOSES; COLD
CREAMS; COLD WAVY SOLUTIONS; HAIR COLOR
REMOVERS; COSMETIC ANTIPERSPIRANTS; COS-
METIC BATH OILS; COSMETIC BATH POWDER; COS-

CLASS 3—(Continued).

METIC BATH SALTS; COSMETIC CLEANSING
CREAMS; COSMETIC CREAMS FOR SKIN CARE; COS-
METIC FACE CREAMS; COSMETIC FACE POWDER;
COSMETIC LIQUID FOUNDATIONS; COSMETIC
NOURISHING CREAMS; COSMETIC OILS FOR THE
EPIDERMIS; COSMETIC PENCILS; COSMETIC PRE-
PARATIONS AGAINST SUNBURN; COSMETIC PRE-
PARATIONS FOR SLIMMING PURPOSES; COSMETIC
ROUGES; COSMETIC SKIN FRESHENERS; COSMETIC
SUN MILK LOTIONS; COSMETIC SUN OILS; COSMETIC
SUN-PROTECTING PREPARATIONS; COSMETIC
WHITE FACE POWDER; COSMETICS FOR ANIMALS;
COSMETIC CREAMS; CREAMY FOUNDATION; DEO-
DORANTS FOR PERSONAL USE; DEPILATORIES; DE-
PILATORY WAX; HAIR DYES; EAU DE COLOGNE;
EAU DE PARFUM; EAU DE TOILETTE; ENAMEL FOR
NAIL MANICURES; ESSENTIAL OILS FOR PERSONAL
USE; ETHEREAL ESSENCES; EYE CREAM; EYE LO-
TIONS; EYE MAKE-UP REMOVER; EYE PENCILS; EYE
SHADOWS; EYEBROW COSMETICS; EYEBROW PEN-
CILS; COSMETIC PREPARATIONS FOR EYELASHES;
EYELINER; EYELINER PENCILS; FACE AND BODY
CREAMS; FACE AND BODY LOTIONS; FACE AND
BODY MILK; FACE MILK AND LOTIONS; FACIAL
CLEANSING MILK; FACIAL CREAM; FACIAL LOTION;
FOUNDATIONS; FRAGRANCES FOR PERSONAL USE;
GREASES FOR COSMETIC PURPOSES; HAIR BALM;
HAIR BLEACHES; HAIR CARE CREAMS; HAIR CARE
LOTIONS; HAIR COLORANTS; HAIR CONDITIONERS;
HAIR CONDITIONING OILS; HAIR DRYING PREPARA-
TIONS; HAIR GEL; HAIR GLAZE; HAIR LACQUERS;
HAIR LOTIONS; HAIR MASCARA; HAIR MOUSSE;
HAIR NOURISHERS; HAIR OILS; HAIR POMADES;
HAIR POWDERS; HAIR SPRAY; HAIR STYLING GEL;
HAIR STYLING SPRAY; HAIR WAVY PREPARA-
TIONS; HAND LOTIONS; HYDROGEN PEROXIDE FOR
COSMETIC PURPOSES; LAVENDER WATER; SACHETS
FOR PERFUMING LINEN; LIP CONDITIONERS; LIP
LINER; LIP POLISHER; LIPSTICKS; LIQUID PER-
FUMES; LIQUID ROUGE; LOOSE FACE POWDER;
LOTIONS FOR BEARDS; LOTIONS FOR COSMETIC
PURPOSES; LOTIONS FOR FACE AND BODY CARE;
LOTIONS FOR STRENGTHENING THE NAILS; MAKE-
UP; MAKE-UP FOUNDATIONS; MAKE-UP POWDER;
MASCARA; MASK PACK FOR COSMETIC PURPOSES;
MASSAGE GELS OTHER THAN FOR MEDICAL PUR-
POSES; MASSAGE OIL; MOUSTACHE WAX; NAIL CARE
PREPARATIONS; NAIL COLORANTS; NAIL DECOLOR-
ANTS; NAIL POLISH; NAIL POLISH REMOVER; NAIL
POLISHING POWDER; NAIL VARNISH FOR COSMETIC
PURPOSES; NON-MEDICATED BATH SALTS; OILS FOR
COSMETIC PURPOSES; PERFUMED CREAMS; PER-
FUMED PASTE; PERFUMED TALCUM POWDER; PER-
FUMES; PERFUMING SACHETS; PERMANENT WAVE
PREPARATIONS; PERMANENT WAVY LOTIONS;
PETROLEUM JELLY FOR COSMETIC PURPOSES; PO-
MADES; PRE-SHAVE CREAMS; PRESSED FACE POW-
DER; HAIR FIXERS; HAIR CREAMS FOR COSMETIC
PURPOSES; COSMETIC HAIR DRESSING PREPARA-
TIONS; HAIR TONIC FOR COSMETIC USE; PERFUMED
TALCUM POWDER FOR COSMETIC USE; SUN SCREEN
CREAMS FOR COSMETIC USE; SUN SCREEN LOTIONS
FOR COSMETIC USE; MOISTURIZING PREPARATIONS
FOR HAIR NOT FOR MEDICAL PURPOSES; SUN TAN
CREAMS; SUN TAN LOTION; SUN-TANNING PRE-
PARATIONS; TALCUM POWDER FOR TOILET USE;
TOILET WATER; VANISHING CREAM; VARNISH-RE-
MOVING PREPARATIONS; WHITE FACE POWDER;
BABY POWDER; BAY RUMS FOR COSMETIC USE;
COSMETIC PREPARATIONS FOR DRY SKIN DURING
PREGNANCY; MAKE-UP BASES IN THE FORM OF
PASTES; ROUGE; SHAVING CREAMS; SHAVING
FOAM; SHAVING GELS; SHAVING LOTIONS; SHAVING
PREPARATIONS; SHOWER AND BATH FOAM;
SHOWER AND BATH GEL; SHOWER CREAMS;
SHOWER GELS; COSMETIC PREPARATIONS FOR SKIN
CARE; SKIN CLEANSERS; SKIN CREAMS; SKIN
CREAMS NOT FOR MEDICAL PURPOSES; SKIN LO-
TIONS; SKIN WHITENING CREAMS; SOLID POWDER
FOR COMPACTS COSMETICS; SUN-BLOCK LOTIONS
(U.S. CLS. 1, 4, 6, 50, 51 AND 52).

CORY BOONE, EXAMINING ATTORNEY

CLASS 3—(Continued).

SN 79-102,702. FENICE - S.P.A., ITALY, FILED 7-8-2011.



OWNER OF INTERNATIONAL REGISTRATION 1091090 DATED 7-8-2011, EXPIRES 7-8-2021.

OWNER OF U.S. REG. NO. 2,569,136.

NO CLAIM IS MADE TO THE EXCLUSIVE RIGHT TO USE "LEATHER PROFESSIONALS", APART FROM THE MARK AS SHOWN.

THE COLOR(S) GOLD, GREEN, WHITE, RED AND BLACK IS/ARE CLAIMED AS A FEATURE OF THE MARK.

THE MARK CONSISTS OF THE WORDING "FENICE" IN CAPITAL GOLD BLOCK LETTERS. ON THE LETTER "I" INSTEAD OF THE POINT THERE IS A BLACK OUTLINED HEART WITH VERTICAL STRIPES APPEARING IN GREEN, WHITE, AND RED. DIRECTLY UNDERNEATH APPEARS THE WORDING "THE LEATHER PROFESSIONALS" IN BLACK.

THE ENGLISH TRANSLATION OF THE WORD "FENICE" IN THE MARK IS "PHOENIX".

FOR NATURAL AND SYNTHETIC WAXES FOR LEATHER, POLISHES FOR LEATHER, DETERGENTS FOR LEATHER, CLEANERS FOR LEATHER, ANTI-STATIC FOR LEATHER, ALL PRODUCTS USED IN THE MANUFACTURE OF LEATHER, FOR CLEANING, PRESERVING, RENOVATION OF LEATHER AND ANIMAL SKIN ARTICLES (U.S. CLS. 1, 4, 6, 50, 51 AND 52).

JACLYN KIDWELL WALKER, EXAMINING ATTORNEY

SN 79-102,793. SCHICK MEDICAL GMBH, 78628 ROTTWEIL, FED REP GERMANY, FILED 8-1-2011.

xcential

THE MARK CONSISTS OF STANDARD CHARACTERS WITHOUT CLAIM TO ANY PARTICULAR FONT, STYLE, SIZE, OR COLOR.

PRIORITY DATE OF 6-9-2011 IS CLAIMED.

OWNER OF INTERNATIONAL REGISTRATION 1091381 DATED 8-1-2011, EXPIRES 8-1-2021.

THE WORDING "XCENTIAL" HAS NO MEANING IN A FOREIGN LANGUAGE.

FOR BLEACHING PREPARATIONS AND LAUNDRY BLEACH, ALL FOR LAUNDRY USE; CLEANING, POLISHING, SCOURING AND ABRASIVE PREPARATIONS; COSMETIC SOAPS, PERFUMERY, ESSENTIAL OILS, COSMETICS; COSMETICS, IN PARTICULAR CREAMS, SKIN WHITENING CREAMS, BLEACHING PREPARATIONS, NAMELY, DECOLORANTS, FOR THE CARE OF THE SKIN FOR COSMETIC PURPOSES, NON-MEDICATED GELS FOR THE CARE OF THE SKIN FOR COSMETIC PURPOSES, LOTIONS FOR COSMETIC PURPOSES, OILS FOR TOILET PURPOSES, NAMELY, COSMETIC OILS, CLEANSING MILK FOR TOILET PURPOSES; HAIR LOTIONS; DENTIFRICES (U.S. CLS. 1, 4, 6, 50, 51 AND 52).

SHAILA SETTLES, EXAMINING ATTORNEY

CLASS 3—(Continued).

SN 79-103,453. ÖZCAN ISIK, KUNGENS KURVA, SWEDEN, FILED 8-19-2011.

Exit

THE MARK CONSISTS OF STANDARD CHARACTERS WITHOUT CLAIM TO ANY PARTICULAR FONT, STYLE, SIZE, OR COLOR.

PRIORITY DATE OF 3-1-2011 IS CLAIMED.

OWNER OF INTERNATIONAL REGISTRATION 1093095 DATED 8-19-2011, EXPIRES 8-19-2021.

FOR SOAPS; PERFUMERY, ESSENTIAL OILS, COSMETICS, HAIR LOTIONS; HAIR CONDITIONERS; HAIR LIGHTENER; HAIR BLEACHING PREPARATIONS; HAIR DYES; HAIR GELS; HAIR LOTIONS; HAIR MOUSSE; HAIR OIL; HAIR SHAMPOO; HAIR SPRAY; HAIR LACQUERS; HAIR TONIC; HAIR-CARE PREPARATIONS; HAIR STYLING PREPARATIONS (U.S. CLS. 1, 4, 6, 50, 51 AND 52).

CARYN GLASSER, EXAMINING ATTORNEY

SN 79-103,481. RODGER HAMES, AUSTRALIA, FILED 8-22-2011.

VuPlex

THE MARK CONSISTS OF STANDARD CHARACTERS WITHOUT CLAIM TO ANY PARTICULAR FONT, STYLE, SIZE, OR COLOR.

OWNER OF INTERNATIONAL REGISTRATION 1033086 DATED 2-23-2010, EXPIRES 2-23-2020.

FOR PLASTIC SURFACE CLEANER AND POLISH (U.S. CLS. 1, 4, 6, 50, 51 AND 52).

AISHA CLARKE, EXAMINING ATTORNEY

SN 79-105,675. PROCTER & GAMBLE; INTERNATIONAL OPERATIONS SA, SWITZERLAND, FILED 10-18-2011.

RED SIN

THE MARK CONSISTS OF STANDARD CHARACTERS WITHOUT CLAIM TO ANY PARTICULAR FONT, STYLE, SIZE, OR COLOR.

PRIORITY DATE OF 5-19-2011 IS CLAIMED.

OWNER OF INTERNATIONAL REGISTRATION 1098086 DATED 10-18-2011, EXPIRES 10-18-2021.

FOR SOAPS, PERFUMERY, ESSENTIAL OILS, COSMETICS, HAIR LOTIONS, DENTIFRICES (U.S. CLS. 1, 4, 6, 50, 51 AND 52).

KRISTINA MORRIS, EXAMINING ATTORNEY

CLASS 3—(Continued).

SN 85-011,791. O P I PRODUCTS, INC., NORTH HOLLYWOOD, CA. FILED 4-12-2010.

NICOLE BY OPI NAIL APPS

THE MARK CONSISTS OF STANDARD CHARACTERS WITHOUT CLAIM TO ANY PARTICULAR FONT, STYLE, SIZE, OR COLOR.

OWNER OF U.S. REG. NOS. 2,300,077, 3,164,420 AND OTHERS.

NO CLAIM IS MADE TO THE EXCLUSIVE RIGHT TO USE "NAIL APPS", APART FROM THE MARK AS SHOWN.

FOR NAIL COATING, NAMELY, DECORATIVE DECALS, WHICH ARE APPLIED THROUGH AN ADHESIVE METHOD (U.S. CLS. 1, 4, 6, 50, 51 AND 52).

LINDA ESTRADA, EXAMINING ATTORNEY

CLASS 3—(Continued).

SN 85-134,661. BUMBLE AND BUMBLE, LLC, NEW YORK, NY. FILED 9-21-2010.

The logo features the letters 'BB.' in a large, bold, black, hand-drawn font. Below it, the words 'LET IT SHINE' are written in a smaller, bold, black, hand-drawn font. The entire logo is centered on the page.

OWNER OF U.S. REG. NOS. 3,385,377, 3,641,235 AND OTHERS.

NO CLAIM IS MADE TO THE EXCLUSIVE RIGHT TO USE "SHINE", APART FROM THE MARK AS SHOWN.

THE MARK CONSISTS OF "BB. LET IT SHINE" IN STYLED FORM.

FOR HAIR CARE PREPARATIONS (U.S. CLS. 1, 4, 6, 50, 51 AND 52).

SUSAN STIGLITZ, EXAMINING ATTORNEY

SN 85-042,826. BARZILAI, TADMOR TEDDY, SAN DIEGO, CA. FILED 5-19-2010.

ARGANICA

THE MARK CONSISTS OF STANDARD CHARACTERS WITHOUT CLAIM TO ANY PARTICULAR FONT, STYLE, SIZE, OR COLOR.

FOR COSMETICS (U.S. CLS. 1, 4, 6, 50, 51 AND 52).

MARK RADEMACHER, EXAMINING ATTORNEY

SN 85-143,618. AMOREPACIFIC CORPORATION, SEOUL, REPUBLIC OF KOREA, FILED 10-1-2010.

BENECIRCLE

SN 85-098,797. VALENTE, SAL, BARRIE, ONTARIO, CANADA, FILED 8-3-2010.

Smile Naturally

THE MARK CONSISTS OF STANDARD CHARACTERS WITHOUT CLAIM TO ANY PARTICULAR FONT, STYLE, SIZE, OR COLOR.

PRIORITY CLAIMED UNDER SEC. 44(D) ON CANADA APPLICATION NO. 1485068, FILED 6-14-2010, REG. NO. TMA808,812, DATED 10-12-2011, EXPIRES 10-12-2026.

FOR TOOTH BLEACHING GEL; TOOTH WHITENING GEL; TOOTH POLISHING CREAM; TOOTH PASTE; TOOTH GEL; MOUTHWASH; MOUTH RINSE; PREVENTATIVE MAINTENANCE ORAL CARE PRODUCTS COMPRISED OF TOOTH WHITENING GEL, GEL APPLICATORS, GEL TRAYS, TOOTH CLEANING GELS, TOOTH PASTE, AND RINSES SOLD TOGETHER AS A UNIT (U.S. CLS. 1, 4, 6, 50, 51 AND 52).

JENNIFER VASQUEZ, EXAMINING ATTORNEY

THE MARK CONSISTS OF STANDARD CHARACTERS WITHOUT CLAIM TO ANY PARTICULAR FONT, STYLE, SIZE, OR COLOR.

OWNER OF REPUBLIC OF KOREA REG. NO. 40-0887787, DATED 11-1-2011, EXPIRES 11-1-2021.

FOR COSMETICS; COSMETIC CREAMS; TOILET WATER; NON-MEDICATED NOURISHING CREAMS FOR SKIN; COSMETIC PREPARATIONS FOR SKIN CARE; CREAMY FOUNDATION; CLEANSING CREAMS; MASSAGE CREAMS; SUNSCREEN CREAMS; SKIN WHITENING CREAMS; MAKE-UP POWDER; MASCARA; EYE SHADOWS; LIPSTICKS; DENTIFRICES; DETERGENTS FOR HOUSEHOLD USE; POLISHING WAX; ABRASIVES, NAMELY, FLEXIBLE ABRASIVES (U.S. CLS. 1, 4, 6, 50, 51 AND 52).

WANDA KAY PRICE, EXAMINING ATTORNEY

CLASS 3—(Continued).

SN 85-172,164. MILLIKEN & COMPANY, SPARTANBURG, SC. FILED 11-9-2010.

OWNER OF U.S. REG. NOS. 2,274,504, 2,281,638 AND OTHERS.
THE MARK CONSISTS OF "MILLIKEN" IN CURSIVE WRITING.
SEC. 2(F).
FOR CLEANING PREPARATIONS CONSISTING OF POROUS, ABSORBENT PARTICLES IN POWDER FORM, A LIQUID CONCENTRATE OR DILUTE LIQUID OR TABLET FORM FOR USE IN THE CLEANING OF CARPETS AND UPHOLSTERY; ALL PURPOSE CLEANING PREPARATIONS; CARPET CLEANING KITS COMPOSED OF CARPETING CLEANING PREPARATIONS (U.S. CLS. 1, 4, 6, 50, 51 AND 52).
LINDA ESTRADA, EXAMINING ATTORNEY

CLASS 3—(Continued).

SN 85-231,423. SWEET WHEAT, INC., CLEARWATER, FL. FILED 2-1-2011.

THE MARK CONSISTS OF STANDARD CHARACTERS WITHOUT CLAIM TO ANY PARTICULAR FONT, STYLE, SIZE, OR COLOR.
NO CLAIM IS MADE TO THE EXCLUSIVE RIGHT TO USE "SKIN", APART FROM THE MARK AS SHOWN.
FOR MOISTURIZING CREAM (U.S. CLS. 1, 4, 6, 50, 51 AND 52).
FIRST USE 4-1-2000; IN COMMERCE 4-1-2000.
PATRICIA EVANKO, EXAMINING ATTORNEY

SN 85-268,274. COLOMER ITALY, S.P.A., BOLOGNA, ITALY, FILED 3-16-2011.

SN 85-191,983. GLOBAL HAIR GROUP PTY LTD, THORN- LANDS, QUEENSLAND, AUSTRALIA, FILED 12-7-2010.

THE MARK CONSISTS OF STANDARD CHARACTERS WITHOUT CLAIM TO ANY PARTICULAR FONT, STYLE, SIZE, OR COLOR.
NO CLAIM IS MADE TO THE EXCLUSIVE RIGHT TO USE "SILK", APART FROM THE MARK AS SHOWN.
FOR HAIR COLOURING PREPARATIONS, HAIR COLOUR, HAIR DYES, HAIR CARE PREPARATIONS, HAIR LIGHTENERS, COSMETIC PREPARATIONS FOR THE HAIR AND SCALP AND NON-MEDICATED HAIR TREATMENT PREPARATIONS FOR COSMETIC PURPOSES, ALL THE FOREGOING CONTAINING A SIGNIFICANT PROPORTION OF SILK (U.S. CLS. 1, 4, 6, 50, 51 AND 52).
NANCY CLARKE, EXAMINING ATTORNEY

THE MARK CONSISTS OF STANDARD CHARACTERS WITHOUT CLAIM TO ANY PARTICULAR FONT, STYLE, SIZE, OR COLOR.
THE ENGLISH TRANSLATION OF "ESTRO" IN THE MARK IS "INSPIRATION".
FOR HAIR CARE LOTIONS; HAIR CARE PREPARATIONS; HAIR CLEANING PREPARATIONS; HAIR CONDITIONER; SHAMPOO; HAIR MASKS; HAIR CREAMS; HAIR COLORING PREPARATIONS; HAIR DYES; HAIR GELS; HAIR WAXES; HAIR MOUSSE; HAIR SPRAYS; HAIR OILS; HAIR NOURISHERS; HAIR POMADES; HAIR STYLING PREPARATIONS; PREPARATIONS FOR PERMANENT HAIR WAVES; HAIR WAVING PREPARATIONS; HAIR EMOLLIENTS; AND NONMEDICATED HAIR SERUM (U.S. CLS. 1, 4, 6, 50, 51 AND 52).
MICHAEL ENGEL, EXAMINING ATTORNEY

CLASS 3—(Continued).

SN 85-274,307. MASCOTTE HOLDINGS, INC., NEW YORK, NY. FILED 3-23-2011.

YEEZI

THE MARK CONSISTS OF STANDARD CHARACTERS WITHOUT CLAIM TO ANY PARTICULAR FONT, STYLE, SIZE, OR COLOR.

THE NAME SHOWN IN THE MARK IDENTIFIES KANYE WEST A LIVING INDIVIDUAL, WHOSE CONSENT TO REGISTER IS MADE OF RECORD.

FOR COSMETICS; FACIAL MAKEUP, CONCEALERS, BLUSHERS, FACIAL POWDERS, FOUNDATION MAKEUP, EYE MAKEUP, EYE PENCILS, EYEBROW PENCILS, MASCARA, FALSE EYELASHES, FACE AND BODY GLITTER, COSMETIC COMPACTS, COSMETIC PENCILS, LIPSTICK, LIPSTICK CASES, LIPSTICK HOLDERS, LIP GLOSS, LIP POMADES, LIP PENCILS, MAKEUP REMOVERS, MAKEUP APPLICATORS IN THE NATURE OF COTTON SWABS FOR COSMETIC PURPOSES, EYE CREAMS, FACIAL CLEANSERS, TONERS, FACIAL EXFOLIANTS AND SCRUBS, FACIAL CREAMS, FACIAL MOISTURIZERS, AND FACIAL LOTIONS; NON-MEDICATED FACIAL TREATMENTS, NAMELY, NON-MEDICATED FACIAL EMULSIONS, NON-MEDICATED FACIAL MASKS, NON-MEDICATED ACNE TREATMENT PREPARATIONS, AND NON-MEDICATED OINTMENTS FOR THE PREVENTION AND TREATMENT OF SUNBURN; WRINKLE REMOVING SKIN CARE PREPARATIONS, NAIL POLISHES, NAIL POLISH BASE COAT, NAIL POLISH TOP COAT, NAIL STRENGTHENERS, NAIL HARDENERS, NAIL POLISH REMOVERS, NAIL CREAMS, CUTICLE REMOVING PREPARATIONS, NAIL TIPS, AND NAIL BUFFING PREPARATIONS; BEAUTY MILKS, SKIN MOISTURIZERS AND SKIN MOISTURIZER MASKS, SKIN CONDITIONERS, HAND CREAMS, MASSAGE OILS, ESSENTIAL OILS FOR PERSONAL USE, TALCUM POWDER, PERFUMED POWDERS, BATH BEADS, BATH CRYSTALS, BATH FOAM, BATH GELS, BATH OILS, BATH POWDERS, BATH SALTS, FACIAL WASH, SKIN CLEANSERS, SKIN HIGHLIGHTER IN THE NATURE OF A SKIN BRONZER, BODY SCRUBS, BODY FRAGRANCES, FRAGRANCES FOR PERSONAL USE, BODY AND HAND LOTIONS; BODY GELS, NAMELY, SHOWER GELS, SUN TAN GELS, BATH GELS, BEAUTY GELS AND SHOWER GELS; BODY OILS, BODY POWDERS, BODY EXFOLIANTS, BODY MASKS, BODY MASK CREAMS AND LOTIONS, SHAVING PREPARATIONS, AFTER SHAVE LOTIONS, SHAVING BALM, SHAVING CREAM, SHAVING GEL, SKIN ABRASIVE PREPARATIONS, NON-MEDICATED SKIN CREAMS AND SKIN LOTIONS FOR RELIEVING RAZOR BURNS, NON-MEDICATED LIP CARE PREPARATIONS, LIP CREAM, SUNSCREEN PREPARATIONS, SUNTANNING PREPARATIONS AND AFTER-SUN LOTIONS; COSMETIC SUN-PROTECTING PREPARATIONS; SUN TAN OILS; SELF-TANNING PREPARATIONS, NAMELY, SELF TANNING MILK AND CREAM, ACCELERATED TANNING CREAM, SELF-TANNING LOTIONS, GELS AND OILS IN SPRAY FORM; PERFUME, PERFUME OILS, COLOGNE, EAU DE TOILETTE, EAU DE PERFUME, EAU DE COLOGNE AND TOILETTE WATER; TOOTHPASTE, DEODORANT AND ANTIPERSPIRANT; COSMETIC PADS, PRE-MOISTENED COSMETIC WIPES, PRE-MOISTENED COSMETIC TISSUES AND TOWELLETTES; COTTON STICKS FOR COSMETIC PURPOSES; ALL PURPOSE COTTON SWABS FOR PERSONAL USE AND COSMETIC PURPOSES; NON-MEDICATED TOPICAL OINTMENTS FOR THE PREVENTION AND TREATMENT OF SUNBURN; NON-MEDICATED TOPICAL SKIN CREAMS, GELS, TONERS, LOTIONS AND SPRAYS ALL FOR COSMETIC USE; NON-MEDICATED TOPICAL SKIN POWDER, NAMELY, NON-MEDICATED MAKE-UP POWDER AND NON-MEDICATED DUSTING POWDER; HAIR CARE PRODUCTS, NAMELY, SHAMPOOS, CONDITIONERS, MOUSSE, GELS, FROSTS, CREAMS, RINSES, SPRAYS, HAIR COLOR, HAIR WAVING LOTION, PERMANENT WAVE PREPARATIONS,

CLASS 3—(Continued).

HAIR LIGHTENERS, HAIR DYES, HAIR EMOLLIENTS, HAIR MASCARA, HAIR POMADES, HAIR COLOR REMOVERS, HAIR RELAXING PREPARATIONS, HAIR STYLING PREPARATIONS, HAIR REMOVING CREAM, AND HAIR CARE PREPARATIONS; ASTRINGENTS FOR COSMETIC PURPOSES; BABY WIPES; DISPOSABLE WIPES IMPREGNATED WITH CLEANSING CHEMICALS OR COMPOUNDS FOR PERSONAL HYGIENE AND HOUSEHOLD USE; INCENSE; ROOM FRAGRANCES; FRAGRANCE EMITTING WICKS FOR ROOM FRAGRANCES; SACHETS; SACHET-LIKE EYE PILLOWS CONTAINING FRAGRANCES; SCENTED CERAMIC STONES; SCENTED LINEN SPRAYS AND SCENTED ROOM SPRAYS; SCENTED OILS USED TO PRODUCE AROMAS WHEN HEATED; SCENTED PINE CONES; POTPOURRI; AROMATIC PILLOWS COMPRISING POTPOURRI IN FABRIC CONTAINERS (U.S. CLS. 1, 4, 6, 50, 51 AND 52).

CHARISMA HAMPTON, EXAMINING ATTORNEY

SN 85-291,559. COUTURE COLOUR LLC, LOS ANGELES, CA. FILED 4-11-2011.

COUTURE COLOUR PRO GLAZE WITH PEQUI OIL

THE MARK CONSISTS OF STANDARD CHARACTERS WITHOUT CLAIM TO ANY PARTICULAR FONT, STYLE, SIZE, OR COLOR.

OWNER OF U.S. REG. NOS. 3,987,280 AND 3,987,292.

NO CLAIM IS MADE TO THE EXCLUSIVE RIGHT TO USE "COLOUR PRO GLAZE WITH PEQUI OIL", APART FROM THE MARK AS SHOWN.

FOR HAIR CARE PREPARATIONS CONTAINING PEQUI OIL (U.S. CLS. 1, 4, 6, 50, 51 AND 52).

ANNE FARRELL, EXAMINING ATTORNEY

SN 85-292,448. RETAIL ROYALTY COMPANY, LAS VEGAS, NV. FILED 4-12-2011.

AERIE SHEER

THE MARK CONSISTS OF STANDARD CHARACTERS WITHOUT CLAIM TO ANY PARTICULAR FONT, STYLE, SIZE, OR COLOR.

OWNER OF U.S. REG. NOS. 3,419,683, 3,584,874 AND OTHERS.

FOR BODY CREAMS; FRAGRANCES; PERFUME (U.S. CLS. 1, 4, 6, 50, 51 AND 52).

KELLY TRUSILO, EXAMINING ATTORNEY

CLASS 3—(Continued).

SN 85-294,840. NAIL PARTNER KABUSHIKI KAISHA, DBA NAIL PARTNER CO., LTD., TOKYO, JAPAN, FILED 4-14-2011.

ace gel

THE MARK CONSISTS OF STANDARD CHARACTERS WITHOUT CLAIM TO ANY PARTICULAR FONT, STYLE, SIZE, OR COLOR.

NO CLAIM IS MADE TO THE EXCLUSIVE RIGHT TO USE "GEL", APART FROM THE MARK AS SHOWN.

FOR COSMETICS; FALSE NAILS (U.S. CLS. 1, 4, 6, 50, 51 AND 52).

MICHAEL WEBSTER, EXAMINING ATTORNEY

SN 85-300,099. ISIS DERMALOGIC, INC., FOUNTAIN VALLEY, CA. FILED 4-20-2011.



THE MARK CONSISTS OF WOMAN IN PROFILE WITH A FLOWER IN HER HAIR WITH "ISIS" BELOW IN STYLIZED FONT.

FOR COSMETIC PREPARATIONS FOR SKIN CARE; NON-MEDICATED SKIN CARE CREAMS AND LOTIONS; NON-MEDICATED SKIN CARE PREPARATIONS (U.S. CLS. 1, 4, 6, 50, 51 AND 52).

MIDGE BUTLER, EXAMINING ATTORNEY

SN 85-302,679. BB ENDEAVORS LLC, NEW YORK, NY. FILED 4-22-2011.

SKINNYGIRL

THE MARK CONSISTS OF STANDARD CHARACTERS WITHOUT CLAIM TO ANY PARTICULAR FONT, STYLE, SIZE, OR COLOR.

OWNER OF U.S. REG. NO. 3,795,804.

FOR ROOM FRAGRANCES; ROOM FRAGRANCE REFILLS FOR NON-ELECTRIC ROOM FRAGRANCE DISPENSERS (U.S. CLS. 1, 4, 6, 50, 51 AND 52).

ANDREA BUTLER, EXAMINING ATTORNEY

CLASS 3—(Continued).

SN 85-304,281. OPIVU PRODUCTS & COSMETICS, LLC, DBA OPIVU COSMETICS, DANVILLE, CA. FILED S.R. 4-25-2011; AM. P.R. 2-2-2012.

LASHMERE

THE MARK CONSISTS OF STANDARD CHARACTERS WITHOUT CLAIM TO ANY PARTICULAR FONT, STYLE, SIZE, OR COLOR.

FOR COLOGNES, PERFUMES AND COSMETICS (U.S. CLS. 1, 4, 6, 50, 51 AND 52).

FIRST USE 12-7-2010; IN COMMERCE 12-7-2010.

NAKWAMA ANKRAH, EXAMINING ATTORNEY

SN 85-310,499. ALLYSON AMES COMPANY, INC., CORONA DEL MAR, CA. FILED 5-3-2011.

WONDERLICIOUS

THE MARK CONSISTS OF STANDARD CHARACTERS WITHOUT CLAIM TO ANY PARTICULAR FONT, STYLE, SIZE, OR COLOR.

OWNER OF U.S. REG. NO. 3,629,516.

FOR PERSONAL CARE PRODUCTS, NAMELY, HAIR CONDITIONERS, SHAMPOOS, SKIN LOTIONS, SKIN SOAPS, BATH GELS, BATH LOTION, BATH SOAPS, BODY CREAM BODY LOTIONS, BUBBLE BATH, CLEANSING CREAMS, COLOGNE, CREAM SOAPS, DUSTING POWDER, EAU DE PARFUM, EAU DE TOILETTE, ESSENTIAL OILS FOR PERSONAL USE, FACE AND BODY CREAMS, FACE AND BODY GLITTER LIQUID SOAP, LIQUID SOAPS FOR HANDS, FACE AND BODY, LOTIONS FOR FACE AND BODY, EYE SHADOW, MASCARA, LIPSTICK, BLUSH AND OTHER COSMETICS (U.S. CLS. 1, 4, 6, 50, 51 AND 52).

FIRST USE 1-1-2005; IN COMMERCE 1-1-2011.

JANICE L. MCMORROW, EXAMINING ATTORNEY

CLASS 3—(Continued).

SN 85-311,344. WARNER ALAN B, DBA TD4, CRESSKILL, NJ. FILED 5-3-2011.



NO CLAIM IS MADE TO THE EXCLUSIVE RIGHT TO USE "ESTD 2011", APART FROM THE MARK AS SHOWN.

THE MARK CONSISTS OF A RECTANGULAR SHAPE AROUND THE WORDING "TD4" WITH A VERTICAL LINE BETWEEN THE "TD" AND "4". A CROWN ADORNS THE TOP OF THE RECTANGLE WITH "ESTD" TO THE LEFT AND "2011" TO THE RIGHT. A RIBBON APPEARS AT THE BOTTOM OF THE RECTANGLE WITH THE WORDING "MEMENTO MORI" INSIDE.

THE ENGLISH TRANSLATION OF MEMENTO MORI IN THE MARK IS "REMEMBER YOUR MORTALITY".

FOR 3-IN-1 ORGANIC SOAP BARS FOR USE AS SOAP, SHAMPOO AND CONDITIONER; AROMATIC BODY CARE PRODUCTS, NAMELY, BODY LOTION, SHOWER GEL, CUTICLE CREAM, SHAMPOO, CONDITIONER, NON-MEDICATED LIP BALM, SOAP, BODY POLISH, BODY AND FOOT SCRUB AND NON-MEDICATED FOOT CREAM; BABY HAND SOAP; BAR SOAP; BATH SOAPS; BATH SOAPS IN LIQUID, SOLID OR GEL FORM; BEAUTY CREAMS; BEAUTY CREAMS FOR BODY CARE; BEAUTY SOAP; BODY CREAM; BODY CREAM SOAP; CLEANSING CREAMS; COLOGNES, PERFUMES AND COSMETICS; COSMETIC CREAMS; COSMETIC SOAPS; COSMETICS IN GENERAL, INCLUDING PERFUMES; CREAM SOAPS; DEODORANT SOAP; EAU DE PERFUME; ESSENTIAL OILS AS PERFUME FOR LAUNDRY PURPOSES; EYE LINER; EYE MAKE-UP; EYE PENCILS; EYE SHADOW; EYELINER PENCILS; EYES MAKE-UP; HAND SOAPS; LIP GLOSS; LIP LINER; LIP POLISHER; LIPSTICK; LIPSTICK CASES; LIPSTICK HOLDERS; LIQUID BATH SOAPS; LIQUID PERFUMES; LIQUID SOAP; LIQUID SOAP USED IN FOOT BATH; LIQUID SOAPS FOR HANDS, FACE AND BODY; LOOFAH SOAPS; MASCARA; NAIL ART STICKERS; NAIL BUFFING PREPARATIONS; NAIL CARE KITS COMPRISING NAIL POLISH; NAIL CARE PREPARATIONS; NAIL CREAM; NAIL ENAMELS; NAIL GEL; NAIL GLITTER; NAIL HARDENERS; NAIL POLISH; NAIL POLISH BASE COAT; NAIL POLISH TOP COAT; NATURAL COCOA BUTTER BASED PERSONAL CARE PRODUCTS, NAMELY, BODY LOTION, SHOWER GEL, SOAP, BODY POLISH, BODY AND FOOT SCRUB AND NON-MEDICATED SKIN CREAMS; NIGHT CREAM; OILS FOR PERFUMES AND SCENTS; ORGANIC SOAP BARS; PERFUME; PERFUME OILS; PERFUMED CREAMS; PERFUMED EXTRACTS FOR TISSUES AND PERFUMES; PERFUMED POWDERS; PERFUMED SOAP; PERFUMED SOAPS; PERFUMED TALCUM POWDER; PERFUMES AND COLOGNES; PERFUMES AND TOILET WATERS; PERFUMES IN SOLID FORM; PERFUMES, AFTERSHAVES AND COLOGNES; PERFUMES, EAU DE COLOGNES AND AFTERSHAVES; PERFUMES, EAUX DE COLOGNE AND AFTERSHAVES; PERFUMING SACHETS; SKIN SOAP; SOAPS FOR BODY CARE (U.S. CLS. 1, 4, 6, 50, 51 AND 52).

TAMARA FRAZIER, EXAMINING ATTORNEY

CLASS 3—(Continued).

SN 85-312,149. RODIAL LIMITED, LONDON, UNITED KINGDOM, FILED 5-4-2011.

RODIAL SKIN BLEACH

THE MARK CONSISTS OF STANDARD CHARACTERS WITHOUT CLAIM TO ANY PARTICULAR FONT, STYLE, SIZE, OR COLOR.

PRIORITY CLAIMED UNDER SEC. 44(D) ON UNITED KINGDOM APPLICATION NO. 2569277, FILED 1-17-2011, REG. NO. 2569277, DATED 4-15-2011, EXPIRES 1-17-2021.

OWNER OF U.S. REG. NO. 3,483,445.

NO CLAIM IS MADE TO THE EXCLUSIVE RIGHT TO USE "SKIN BLEACH", APART FROM THE MARK AS SHOWN.

FOR PERFUMES; NON-MEDICATED BATH PREPARATIONS; NON-MEDICATED TOILET PREPARATIONS, NAMELY, TOILET WATERS AND SOAPS; COSMETIC PREPARATIONS; NON-MEDICATED LOTIONS AND CREAMS FOR USE ON THE SKIN, POWDERS FOR USE ON THE SKIN, NAMELY, BODY POWDERS, DUSTING POWDERS, BABY POWDERS AND FOOT POWDERS; SCRUBBING PREPARATIONS FOR USE ON THE SKIN, NAMELY, BODY SCRUBS, FACIAL SCRUBS; FACE MOISTURIZERS AND TONERS; DEPILATORY PREPARATIONS; DEODORANTS FOR PERSONAL USE; TOILET ARTICLES, NAMELY, SOAPS AND TOILET WATER; LIP BALM; SKIN AND HAIR MASKS; PREPARATIONS FOR CARE OF THE HAIR; SHAMPOOS AND HAIR CONDITIONERS; SOAPS; ESSENTIAL OILS; MASSAGE PREPARATIONS, NAMELY, OILS AND CREAMS; PREPARATIONS FOR CARE OF THE NAILS; COSMETICS FOR SUN SCREENING; COTTON WOOL AND COTTON WOOL BUDS FOR COSMETICS AND TOILET USE; EMERY BOARDS (U.S. CLS. 1, 4, 6, 50, 51 AND 52).

JAMES LOVELACE, EXAMINING ATTORNEY

SN 85-316,268. RIDDEL, HOLLY M., BEVERLY HILLS, CA. FILED 5-9-2011.

.02

THE MARK CONSISTS OF STANDARD CHARACTERS WITHOUT CLAIM TO ANY PARTICULAR FONT, STYLE, SIZE, OR COLOR.

FOR FRAGRANCES FOR PERSONAL USE (U.S. CLS. 1, 4, 6, 50, 51 AND 52).

FIRST USE 5-1-2011; IN COMMERCE 5-1-2011.

ANTHONY RINKER, EXAMINING ATTORNEY

CLASS 3—(Continued).

SN 85-318,549. CONOPCO, INC., ENGLEWOOD CLIFFS, NJ.
FILED 5-11-2011.

CLINICEL

THE MARK CONSISTS OF STANDARD CHARACTERS WITHOUT CLAIM TO ANY PARTICULAR FONT, STYLE, SIZE, OR COLOR.

FOR SOAP FOR PERSONAL USE; PERFUMERY; ESSENTIAL OILS; DEODORANTS AND ANTIPERSPIRANTS; HAIR CARE PRODUCTS, NAMELY, HAIR COLORANTS, HAIR DYES, HAIR LOTIONS, HAIR WAVING PREPARATIONS, SHAMPOOS, CONDITIONERS, HAIR SPRAYS, HAIR DRESSINGS, HAIR LACQUERS, HAIR MOUSSES, HAIR GLAZES, HAIR GELS, HAIR MOISTURIZERS, NON-MEDICATED HAIR TREATMENT PREPARATIONS FOR COSMETIC PURPOSES, HAIR OILS, HAIR TONIC, HAIR CREAMS, NON-MEDICATED BATH AND SHOWER PREPARATIONS; NON-MEDICATED SKIN CARE PREPARATIONS; COSMETICS (U.S. CLS. 1, 4, 6, 50, 51 AND 52).

ZACHARY BELLO, EXAMINING ATTORNEY

SN 85-319,415. BEAUTYBANK INC., NEW YORK, NY.
FILED 5-12-2011.

SR12 COMPLEX

THE MARK CONSISTS OF STANDARD CHARACTERS WITHOUT CLAIM TO ANY PARTICULAR FONT, STYLE, SIZE, OR COLOR.

NO CLAIM IS MADE TO THE EXCLUSIVE RIGHT TO USE "COMPLEX", APART FROM THE MARK AS SHOWN.

FOR COSMETICS; NON-MEDICATED SKIN CARE PREPARATIONS (U.S. CLS. 1, 4, 6, 50, 51 AND 52).

ANDREA HACK, EXAMINING ATTORNEY

SN 85-336,566. KOSE CORPORATION, TOKYO, JAPAN,
FILED 6-2-2011.

AWAKE HERBAL SERVER

THE MARK CONSISTS OF STANDARD CHARACTERS WITHOUT CLAIM TO ANY PARTICULAR FONT, STYLE, SIZE, OR COLOR.

OWNER OF U.S. REG. NOS. 2,353,917, 3,428,669 AND OTHERS.

NO CLAIM IS MADE TO THE EXCLUSIVE RIGHT TO USE "HERBAL", APART FROM THE MARK AS SHOWN.

FOR COSMETICS, PERFUMES, COSMETIC SOAPS, COTTON FOR COSMETIC USE AND HAIR CARE PREPARATIONS (U.S. CLS. 1, 4, 6, 50, 51 AND 52).

TRACY CROSS, EXAMINING ATTORNEY

CLASS 3—(Continued).

SN 85-336,569. KOSE CORPORATION, TOKYO, JAPAN,
FILED 6-2-2011.

AWAKE HERBAL BARRIER

THE MARK CONSISTS OF STANDARD CHARACTERS WITHOUT CLAIM TO ANY PARTICULAR FONT, STYLE, SIZE, OR COLOR.

OWNER OF U.S. REG. NOS. 2,353,917, 3,428,669 AND OTHERS.

NO CLAIM IS MADE TO THE EXCLUSIVE RIGHT TO USE "HERBAL", APART FROM THE MARK AS SHOWN.

FOR COSMETICS, PERFUMES, COSMETIC SOAPS, COTTON FOR COSMETIC USE AND HAIR CARE PREPARATIONS (U.S. CLS. 1, 4, 6, 50, 51 AND 52).

TRACY CROSS, EXAMINING ATTORNEY

SN 85-338,376. TRI-COASTAL DESIGN GROUP, INC.,
WHARTON, NJ. FILED 6-5-2011.

GUM BALL SWEETS

THE MARK CONSISTS OF STANDARD CHARACTERS WITHOUT CLAIM TO ANY PARTICULAR FONT, STYLE, SIZE, OR COLOR.

NO CLAIM IS MADE TO THE EXCLUSIVE RIGHT TO USE "GUM BALL", APART FROM THE MARK AS SHOWN.

FOR BATH GEL; BATH SALTS; BATH SOAPS; BODY CREAM; BODY LOTION; BODY OIL; BODY SCRUB; BODY SPRAYS; BUBBLE BATH; DUSTING POWDER; FOOT SCRUBS; LIP BALM; LIP GLOSS; LIQUID SOAP; NAIL POLISH; REEDS AND SCENTED OILS SOLD AS A UNIT FOR USE IN ROOM SCENT DIFFUSERS (U.S. CLS. 1, 4, 6, 50, 51 AND 52).

JAMES STEIN, EXAMINING ATTORNEY

SN 85-338,383. TRI-COASTAL DESIGN GROUP, INC.,
WHARTON, NJ. FILED 6-5-2011.

CHERRY SUNDAE

THE MARK CONSISTS OF STANDARD CHARACTERS WITHOUT CLAIM TO ANY PARTICULAR FONT, STYLE, SIZE, OR COLOR.

FOR BATH GEL; BATH SALTS; BATH SOAPS; BODY CREAM; BODY LOTION; BODY OIL; BODY SCRUB; BODY SPRAYS; BUBBLE BATH; DUSTING POWDER; FOOT SCRUBS; LIP BALM; LIP GLOSS; LIQUID SOAP; NAIL POLISH; REEDS AND SCENTED OILS SOLD AS A UNIT FOR USE IN ROOM SCENT DIFFUSERS (U.S. CLS. 1, 4, 6, 50, 51 AND 52).

JAMES STEIN, EXAMINING ATTORNEY

CLASS 3—(Continued).

SN 85-339,149. CONOPCO, INC., ENGLEWOOD CLIFFS, NJ. FILED 6-6-2011.

DARK TEMPTATION

THE MARK CONSISTS OF STANDARD CHARACTERS WITHOUT CLAIM TO ANY PARTICULAR FONT, STYLE, SIZE, OR COLOR.

OWNER OF U.S. REG. NOS. 3,631,994 AND 3,684,129. FOR SOAPS; PERFUMERY; ESSENTIAL OILS; DEODORANTS AND ANTIPERSPIRANTS; HAIR CARE PRODUCTS, NAMELY, HAIR COLORANTS, HAIR DYES, HAIR LOTIONS, HAIR WAVING PREPARATIONS, SHAMPOOS, CONDITIONERS, HAIR SPRAYS, HAIR-WASHING POWDER, HAIR DRESSINGS FOR MEN, WOMEN AND CHILDREN, HAIR LACQUERS, HAIR MOUSSES, HAIR GLAZES, HAIR GELS, HAIR MOISTURIZERS IN THE NATURE OF HAIR MOISTURIZING CONDITIONER, HAIR LIQUID, NAMELY, HAIR OILS, HAIR LOTIONS, HAIR CREAMS, HAIR PRESERVATION TREATMENTS IN THE NATURE OF HAIR CONDITIONERS, HAIR DESICCATING TREATMENTS, NAMELY, HAIR OILS, HAIR TONIC, HAIR CREAMS; NON-MEDICATED PREPARATIONS FOR THE BATH AND/OR SHOWER; NON-MEDICATED TOILET PREPARATIONS; NON-MEDICATED SKIN CARE PREPARATIONS; COSMETICS (U.S. CLS. 1, 4, 6, 50, 51 AND 52).

PRISCILLA MILTON, EXAMINING ATTORNEY

CLASS 3—(Continued).

SN 85-350,941. PMC TRADE EXPORT & IMPORT CORP., MIAMI, FL. FILED 6-20-2011.

BRAZILIAN KERAPY

THE MARK CONSISTS OF STANDARD CHARACTERS WITHOUT CLAIM TO ANY PARTICULAR FONT, STYLE, SIZE, OR COLOR.

NO CLAIM IS MADE TO THE EXCLUSIVE RIGHT TO USE "BRAZILIAN", APART FROM THE MARK AS SHOWN. FOR NON-MEDICATED KERATIN TREATMENT HAIR CARE PREPARATIONS (U.S. CLS. 1, 4, 6, 50, 51 AND 52).

TRICIA SONNEBORN, EXAMINING ATTORNEY

SN 85-356,620. AUTUMNPAPER LIMITED, WEST SUSSEX, UNITED KINGDOM, FILED 6-27-2011.

ALEXANDER McQUEEN

THE MARK CONSISTS OF STANDARD CHARACTERS WITHOUT CLAIM TO ANY PARTICULAR FONT, STYLE, SIZE, OR COLOR.

OWNER OF UNITED KINGDOM REG. NO. 2271757, DATED 6-6-2001, RENEWED AS REG. NO. 2271757, DATED 6-17-2011, EXPIRES 6-6-2021.

OWNER OF U.S. REG. NOS. 2,704,896, 3,440,831 AND OTHERS.

THE NAME(S), PORTRAIT(S), AND/OR SIGNATURE(S) SHOWN IN THE MARK DOES NOT IDENTIFY A PARTICULAR LIVING INDIVIDUAL.

FOR PERFUMES, EAU DE TOILETTE, DEODORANTS FOR PERSONAL USE; ESSENTIAL OILS FOR PERSONAL USE; OILS FOR COSMETIC PURPOSES; SOAPS; CLEANSING MILK FOR TOILET PURPOSES; COSMETICS; MAKE-UP PREPARATIONS; MAKE-UP REMOVING PREPARATIONS; COSMETIC PREPARATIONS FOR SKIN CARE, FOR CELLULITE REDUCTION, FOR THE BATH, FOR SUN-TANNING; COSMETIC KITS COMPRISED OF MAKEUP; BEAUTY MASKS; PENCILS FOR COSMETIC PURPOSES; BLUSH; NAIL POLISH; LIPSTICKS; EYE-LINER; HAIR LOTIONS AND NON-MEDICATED PREPARATIONS FOR HAIR CARE; SHAMPOOS; SHAVING PREPARATIONS, SHAVING SOAPS; SHAVING GELS; AFTERSHAVE (U.S. CLS. 1, 4, 6, 50, 51 AND 52).

COURTNEY ALVAREZ, EXAMINING ATTORNEY

SN 85-346,455. STARUCH-CHRISTOPHER, SHARON, COTO DE CAZA, CA. FILED 6-15-2011.

SOURCE SKIN CARE

THE MARK CONSISTS OF STANDARD CHARACTERS WITHOUT CLAIM TO ANY PARTICULAR FONT, STYLE, SIZE, OR COLOR.

NO CLAIM IS MADE TO THE EXCLUSIVE RIGHT TO USE "SKIN CARE", APART FROM THE MARK AS SHOWN. FOR COSMETIC AND NON-MEDICATED SKIN CARE PREPARATIONS; FACIAL CREAMS AND CLEANSERS (U.S. CLS. 1, 4, 6, 50, 51 AND 52).

MARTHA FROMM, EXAMINING ATTORNEY

CLASS 3—(Continued).

SN 85-368,681. NERIUM BIOTECHNOLOGY, INC., SAN ANTONIO, TX. FILED 7-12-2011.

NAE-8

THE MARK CONSISTS OF STANDARD CHARACTERS WITHOUT CLAIM TO ANY PARTICULAR FONT, STYLE, SIZE, OR COLOR.

FOR NON-MEDICATED SKIN CARE PREPARATIONS (U.S. CLS. 1, 4, 6, 50, 51 AND 52).
RAUL CORDOVA, EXAMINING ATTORNEY

SN 85-380,912. ARCHER MANUFACTURING, INC., DANVILLE, CA. FILED 7-26-2011.

BLACK OPS

THE MARK CONSISTS OF STANDARD CHARACTERS WITHOUT CLAIM TO ANY PARTICULAR FONT, STYLE, SIZE, OR COLOR.

OWNER OF U.S. REG. NO. 2,495,513.
FOR FRAGRANCES, PERFUMES AND COLOGNES (U.S. CLS. 1, 4, 6, 50, 51 AND 52).
MICHELLE DUBOIS, EXAMINING ATTORNEY

SN 85-384,637. WATHEN, BOYD J., LEHI, UT. FILED 7-29-2011.

CAPRICIA

THE MARK CONSISTS OF STANDARD CHARACTERS WITHOUT CLAIM TO ANY PARTICULAR FONT, STYLE, SIZE, OR COLOR.

THE WORDING "CAPRICIA" HAS NO MEANING IN A FOREIGN LANGUAGE.

FOR SKIN CARE PREPARATIONS, NAMELY, CLEANSING LOTIONS AND CLEANSING CREAMS, SKIN TONERS, FACIAL MASKS, SKIN SCRUBS, SKIN LOTIONS, SKIN MOISTURIZERS, SKIN CONDITIONERS, SKIN CREAMS, MAKE-UP CONCEALERS, AND COSMETIC LIP PRIMERS; ESSENTIAL OIL SPRAYS FOR PERSONAL USE; PERSONAL DEODORANTS; HAIR SHAMPOOS; HAIR CONDITIONERS; HAIR RINSES; AND FOUNDATION MAKE-UP (U.S. CLS. 1, 4, 6, 50, 51 AND 52).
LINDA MICKLEBURGH, EXAMINING ATTORNEY

CLASS 3—(Continued).

SN 85-394,958. MANUEL MARTINEZ CARBALLO, MEXICO, MEXICO, FILED 8-10-2011.



OWNER OF U.S. REG. NOS. 2,690,392, 3,864,285 AND OTHERS.

NO CLAIM IS MADE TO THE EXCLUSIVE RIGHT TO USE "SHAMPOO" AND "FEM", APART FROM THE MARK AS SHOWN.

THE COLOR(S) BLACK, WHITE AND PINK IS/ARE CLAIMED AS A FEATURE OF THE MARK.

THE MARK CONSISTS OF THE WORDING "SHAMPOO CRE-C FEM" WITH THE WORDS "SHAMPOO" AND "CRE-C" IN WHITE AND THE WORD "FEM" IN PINK SCRIPT LETTERING. THE WORDING IS ON A BLACK BACKGROUND.

THE ENGLISH TRANSLATION OF "CRE-C" IN THE MARK IS "GROW".

SEC. 2(F) AS TO "CRE-C".
FOR 3-IN-1 HAIR SHAMPOOS; AROMATIC BODY CARE PRODUCTS, NAMELY, BODY LOTION, SHOWER GEL, CUTICLE CREAM, SHAMPOO, CONDITIONER, NON-MEDICATED LIP BALM, SOAP, BODY POLISH, BODY AND FOOT SCRUB AND NON-MEDICATED FOOT CREAM; HAIR CARE LOTIONS; HAIR CARE PREPARATIONS; HAIR DRESSINGS FOR WOMEN; HAIR SHAMPOO; HAIR SHAMPOOS AND CONDITIONERS; HAIR SPRAYS AND HAIR GELS; HAIR TONIC; HAIR TONICS; SHAMPOO-CONDITIONERS; SHAMPOOS (U.S. CLS. 1, 4, 6, 50, 51 AND 52).

FIRST USE 1-1-2011. THE MARK WAS FIRST USED ANYWHERE IN A DIFFERENT FORM OTHER THAN THAT SOUGHT TO BE REGISTERED AT LEAST AS EARLY AS 08/31/2001; IN COMMERCE 1-1-2011. THE MARK WAS FIRST USED IN COMMERCE IN A DIFFERENT FORM OTHER THAN THAT SOUGHT TO BE REGISTERED AT LEAST AS EARLY AS 08/31/2001.

MATTHEW MCDOWELL, EXAMINING ATTORNEY

SN 85-396,328. MY BEST FOR U, LLC., NEW YORK, NY. FILED 8-12-2011.

VERY CUTE

THE MARK CONSISTS OF STANDARD CHARACTERS WITHOUT CLAIM TO ANY PARTICULAR FONT, STYLE, SIZE, OR COLOR.

FOR HAIR CARE AND HAIR TREATMENT PREPARATIONS, NAMELY, HAIR SHAMPOO, HAIR CONDITIONERS, HAIR OILS, NON-MEDICATED HAIR BALMS, HAIR CREAMS, HAIR RINSES, HAIR LOTIONS, HAIR GELS; SKIN CARE AND SKIN TREATMENT PREPARATIONS, NAMELY, SKIN CLEANSERS, SKIN LOTIONS, SKIN CREAMS, SKIN MASKS, NON-MEDICATED SKIN GELS, EXFOLIANTS, SKIN MOISTURIZERS, SKIN SOAPS, SKIN TONERS, FACIAL SCRUBS (U.S. CLS. 1, 4, 6, 50, 51 AND 52).
DORITT L. CARROLL, EXAMINING ATTORNEY

CLASS 3—(Continued).

SN 85-396,333. MY BEST FOR U, LLC., NEW YORK, NY. FILED 8-12-2011.

V.C. "VERY CUTE"

THE MARK CONSISTS OF STANDARD CHARACTERS WITHOUT CLAIM TO ANY PARTICULAR FONT, STYLE, SIZE, OR COLOR.

FOR HAIR CARE AND HAIR TREATMENT PREPARATIONS, NAMELY, HAIR SHAMPOO, HAIR CONDITIONERS, HAIR OILS, NON-MEDICATED HAIR BALMS, HAIR CREAMS, HAIR RINSES, HAIR LOTIONS, HAIR GELS; SKIN CARE AND SKIN TREATMENT PREPARATIONS, NAMELY, SKIN CLEANSERS, SKIN LOTIONS, SKIN CREAMS, SKIN MASKS, NON-MEDICATED SKIN GELS, EXFOLIANTS, SKIN MOISTURIZERS, SKIN SOAPS, SKIN TONERS, FACIAL SCRUBS (U.S. CLS. 1, 4, 6, 50, 51 AND 52).

DORITT L. CARROLL, EXAMINING ATTORNEY

CLASS 3—(Continued).

SN 85-399,750. LAPORTE, STEPHEN E., DBA FREEFORM CREATIONS, INC., BURBANK, CA. FILED 8-17-2011.



NO CLAIM IS MADE TO THE EXCLUSIVE RIGHT TO USE "SERIES", APART FROM THE MARK AS SHOWN.

THE MARK CONSISTS OF THE STYLIZED WORDING "FACEMAKER" WITH THE LETTER "F" THEREOF RESEMBLING AN ARCHED EYEBROW, AN EYE AND LONG HAIR STRANDS. THIS APPEARS ABOVE THE STYLIZED WORDING "SERIES" INSIDE THE DESIGN OF A STRIP OF PHOTOGRAPHIC FILM.

FOR COSMETIC CLEANSING CREAMS; COSMETIC PENCILS; COSMETIC ROUGES; COSMETICS AND MAKE-UP; DECORATIVE TRANSFERS FOR COSMETIC PURPOSES; LOTIONS FOR COSMETIC PURPOSES; SKIN FRESHENERS; MAKE-UP KITS COMPRISED OF FOUNDATION MAKEUP, CONCEALERS, FACE POWDERS, LIPSTICKS, MAKEUP ADHESIVES FOR COSMETIC USE AND MAKEUP REMOVERS; OILS FOR COSMETIC PURPOSES; PRIVATE LABEL COSMETICS (U.S. CLS. 1, 4, 6, 50, 51 AND 52).

FIRST USE 6-20-2009; IN COMMERCE 6-20-2009.
DAWN HAN, EXAMINING ATTORNEY

SN 85-397,254. PLA COSMETICS, INC., ATLANTA, GA. FILED 8-12-2011.



NO CLAIM IS MADE TO THE EXCLUSIVE RIGHT TO USE "BEAUTY", APART FROM THE MARK AS SHOWN.

THE COLOR(S) GRAY AND SILVER IS/ARE CLAIMED AS A FEATURE OF THE MARK.

THE MARK CONSISTS OF A SILVER HORIZONTAL LINE WITH A SILVER CIRCLE ABOVE. BELOW THIS IS THE WORD "(PLA) BEAUTY" WITH "PLA" IN GRAY AND "BEAUTY" IN SILVER. THERE ARE PARENTHESES AROUND THE LETTERS "PLA" AND A DIACRITICAL MARK ABOVE THE "A" IN THE LETTERS "PLA".

FOR COSMETICS (U.S. CLS. 1, 4, 6, 50, 51 AND 52).
FIRST USE 11-1-2010; IN COMMERCE 11-1-2010.
LESLEY LAMOTHE, EXAMINING ATTORNEY

SN 85-400,438. AMDERMIK, S.L., PREMIA DEL MAR, BARCELONA, CATALONIA, SPAIN, FILED 8-17-2011.



PRIORITY CLAIMED UNDER SEC. 44(D) ON SPAIN APPLICATION NO. 2994734, FILED 8-8-2011, REG. NO. 2994734, DATED 11-17-2011, EXPIRES 8-8-2021.

THE COLOR(S) BLACK AND MAROON IS/ARE CLAIMED AS A FEATURE OF THE MARK.

THE MARK CONSISTS OF THE WORDING "WORLD" OVER THE WORDING "DERMIC", BOTH IN STYLIZED TEXT AND DISPLAYED IN BLACK WITH A TEAR DROP DEVICE IN MAROON INTERSECTING THE "O" IN WORLD.

FOR PERFUMERY, ESSENTIAL OILS, TOILET SOAPS, HAIR LOTIONS, COSMETICS, BODY AND BEAUTY CARE COSMETICS (U.S. CLS. 1, 4, 6, 50, 51 AND 52).

KATINA MISTER, EXAMINING ATTORNEY

CLASS 3—(Continued).

SN 85-404,939. DOCTOR GORDSHELL'S, LLC, BALTIMORE, MD. FILED 8-23-2011.

Dr. Gordshell's

THE MARK CONSISTS OF STANDARD CHARACTERS WITHOUT CLAIM TO ANY PARTICULAR FONT, STYLE, SIZE, OR COLOR.

THE NAME DOES NOT IDENTIFY A LIVING INDIVIDUAL.

FOR SKIN CREAMS (U.S. CLS. 1, 4, 6, 50, 51 AND 52).
FIRST USE 1-1-1858; IN COMMERCE 1-1-1858.

WILLIAM P. SHANAHAN, EXAMINING ATTORNEY

SN 85-415,630. LABUDA, CHAD A., BRADY, MN. FILED 9-6-2011.

Rooster Magee's Lip Balm

"Keep Your Pecker Happy!"

www.roostermageeslipbalm.com

NO CLAIM IS MADE TO THE EXCLUSIVE RIGHT TO USE "LIP BALM", APART FROM THE MARK AS SHOWN.

THE MARK CONSISTS OF A ROOSTER WITH TWO HENS. THE ROOSTER HAS A BEAK AND A COMB. THE ROOSTER IS HOLDING TWO HENS WITH LONG EYE LASHES AND A CREST. ON THE TOP THERE IS THE STYLIZED TEXT "ROOSTER MAGEE'S LIP BALM". AT THE BOTTOM THERE IS THE STYLIZED TEXT "KEEP YOUR PECKER HAPPY!" "WWW.ROOSTERMAGEESLIPBALM.COM" WRITTEN IN TWO SEPARATE LINES.

FOR LIP BALM (U.S. CLS. 1, 4, 6, 50, 51 AND 52).
KELLY TRUSILO, EXAMINING ATTORNEY

CLASS 3—(Continued).

SN 85-415,807. VERWEST, TIJS, NEW YORK, NY. FILED 9-6-2011.

TIËSTO

THE MARK CONSISTS OF STANDARD CHARACTERS WITHOUT CLAIM TO ANY PARTICULAR FONT, STYLE, SIZE, OR COLOR.

THE NAME "TIËSTO" IDENTIFIES A LIVING INDIVIDUAL WHOSE CONSENT IS OF RECORD.

THE WORDING "TIËSTO" HAS NO MEANING IN A FOREIGN LANGUAGE.

FOR COSMETICS; COSMETIC PREPARATIONS; FRAGRANCES; PERFUMES; PERFUME OILS; PERFUMERY; COLOGNES; EAU DE TOILETTE; EAU DE PARFUM; EAU DE PERFUME; EAU DE COLOGNE; FACE AND BODY LOTIONS AND MOISTURIZERS, NON-MEDICATED TOILETRIES; BODY WASH; BODY GELS; BODY BUTTER; BODY SPRAY; BODY OILS AND MISTS; BODY POWDER; BODY MOISTURIZERS; BODY FRAGRANCES; BATH GELS; BATH OILS; BATH POWDERS; BATH CRYSTALS; BATH FOAM; BATH BEADS; BATH SALTS; SHOWER GELS; COSMETIC PREPARATIONS FOR BATHS; PERFUMED POWDERS; SOAPS; PERFUMED SOAPS; SOAP POWDER; TOILET SOAP; TOILET WATER; SHAVING PREPARATIONS, SHAVING BALM, SHAVING CREAM, SHAVING GEL, AFTER SHAVE LOTIONS, SKIN ABRASIVE PREPARATIONS; NON-MEDICATED SKIN CREAMS WITH ESSENTIAL OILS FOR USE IN AROMATHERAPY; SKIN LOTION, HAND LOTION; FACIAL LOTION; AROMATHERAPY OILS; MASSAGE OILS; TALCUM POWDER, BUBBLE BATH (U.S. CLS. 1, 4, 6, 50, 51 AND 52).

JOHN SCHUYLER YARD, EXAMINING ATTORNEY

SN 85-416,136. UNITED INVESTMENTS OF ILLINOIS INC., SANDWICH, IL. FILED 9-6-2011.

G Beauty Products

THE MARK CONSISTS OF STANDARD CHARACTERS WITHOUT CLAIM TO ANY PARTICULAR FONT, STYLE, SIZE, OR COLOR.

NO CLAIM IS MADE TO THE EXCLUSIVE RIGHT TO USE "BEAUTY PRODUCTS", APART FROM THE MARK AS SHOWN.

FOR FACIAL SCRUBS; BODY SCRUB; SKIN CLEANSERS; SKIN TONERS; BEAUTY SERUMS; EYE CREAM; ANTI-AGING MOISTURIZER; BEAUTY CREAMS; ANTI-WRINKLE CREAMS; SKIN LOTION; SKIN CARE PREPARATIONS, NAMELY, SKIN PEELS; SKIN LIGHTENING CREAMS; SUN-BLOCK LOTIONS; MAKE-UP REMOVER; BODY WASH; LOTIONS FOR CELLULITE REDUCTION; FACIAL LOTION; HAND CREAM (U.S. CLS. 1, 4, 6, 50, 51 AND 52).

FIRST USE 9-1-2009; IN COMMERCE 9-1-2009.
KELLY TRUSILO, EXAMINING ATTORNEY

CLASS 3—(Continued).

SN 85-416,201. ECLECTICA SKIN CARE LLC, LEESBURG, VA. FILED 9-7-2011.

ECLECTICA SKIN CARE BY
ALANA CAPPELLI

THE MARK CONSISTS OF STANDARD CHARACTERS WITHOUT CLAIM TO ANY PARTICULAR FONT, STYLE, SIZE, OR COLOR.

NO CLAIM IS MADE TO THE EXCLUSIVE RIGHT TO USE "SKIN CARE", APART FROM THE MARK AS SHOWN.

THE NAME(S), PORTRAIT(S), AND/OR SIGNATURE(S) SHOWN IN THE MARK IDENTIFIES "ALANA CAPPELLI", WHOSE CONSENT(S) TO REGISTER IS MADE OF RECORD.

THE WORD(S) "ECLECTICA" HAS NO MEANING IN A FOREIGN LANGUAGE.

FOR SKIN CLEANSERS; SKIN MOISTURIZERS; MAKE-UP (U.S. CLS. 1, 4, 6, 50, 51 AND 52).

KATHERINE STOIDES, EXAMINING ATTORNEY

CLASS 3—(Continued).

SN 85-423,254. OPTIMUM REFLECTIONS INC, LEWISVILLE, TX. FILED 9-15-2011.



NO CLAIM IS MADE TO THE EXCLUSIVE RIGHT TO USE "I" TIME, APART FROM THE MARK AS SHOWN.

THE STIPPLING IS FOR SHADING PURPOSES ONLY.

THE MARK CONSISTS OF A FOUR-POINT SHIELD WITH THE STYLIZED TEXT "SPS" IN THE UPPER CENTER OF THE SHIELD. THE STYLIZED TEXT "IX" IS IN THE LOWER HALF OF THE SHIELD.

FOR AUTOMOBILE POLISH (U.S. CLS. 1, 4, 6, 50, 51 AND 52).

DAWN HAN, EXAMINING ATTORNEY

SN 85-422,304. FIRST 3D LLC, LAS VEGAS, NV. FILED 9-14-2011.

L'CORE

THE MARK CONSISTS OF STANDARD CHARACTERS WITHOUT CLAIM TO ANY PARTICULAR FONT, STYLE, SIZE, OR COLOR.

FOR HAND CREAM, BODY LOTION, SOAP, NON-MEDICATED BATH SALTS, SKIN MOISTURIZER CREAM, NOURISHING SKIN CREAM, NON-MEDICATED FOOT CREAM, NON-MEDICATED EYE SERUM, NON-MEDICATED FACIAL SERUM, EYE CREAM, MUD MASK BEING FACIAL MASK, HYDRATING MASK BEING FACIAL MASK, COLLAGEN CREAM BEING NON-MEDICATED SKIN CREAM, COLLAGEN MASK BEING SKIN MASK, COLLAGEN SERUM BEING NON-MEDICATED SKIN SERUM, COSMETICS, SKIN CARE LOTION, FACIAL CREAM (U.S. CLS. 1, 4, 6, 50, 51 AND 52).

RUDY R. SINGLETON, EXAMINING ATTORNEY

SN 85-430,140. TAMIKIO BOHLER SMITH, AKA MIKIOS NATURAL BODY SCRUB, POWDER SPRINGS, GA. FILED S.R. 9-23-2011; AM. P.R. 2-3-2012.

Mikios Natural Body Scrub



NO CLAIM IS MADE TO THE EXCLUSIVE RIGHT TO USE "NATURAL BODY SCRUB", APART FROM THE MARK AS SHOWN.

THE COLOR(S) ORANGE, PINK, YELLOW GOLD IS/ARE CLAIMED AS A FEATURE OF THE MARK.

THE MARK CONSISTS OF WORDING "MIKIOS NATURAL BODY SCRUB" IN ORANGE OVER A DESIGN OF CURVED LINES IN THE COLORS OF PINK, ORANGE, AND YELLOW GOLD.

FOR AROMATIC BODY CARE PRODUCTS, NAMELY, BODY LOTION, SHOWER GEL, CUTICLE CREAM, SHAMPOO, CONDITIONER, NON-MEDICATED LIP BALM, SOAP, BODY POLISH, BODY AND FOOT SCRUB AND NON-MEDICATED FOOT CREAM; BODY SCRUB (U.S. CLS. 1, 4, 6, 50, 51 AND 52).

FIRST USE 4-1-2011; IN COMMERCE 4-1-2011.

LINDA M. KING, EXAMINING ATTORNEY

CLASS 3—(Continued).

SN 85-433,690. TIM TAM LICENSING, INC., INDIANAPOLIS, IN. FILED 9-28-2011.

WILLIAM ROAM

THE MARK CONSISTS OF STANDARD CHARACTERS WITHOUT CLAIM TO ANY PARTICULAR FONT, STYLE, SIZE, OR COLOR.

THE NAME(S), PORTRAIT(S), AND/OR SIGNATURE(S) SHOWN IN THE MARK DOES NOT IDENTIFY A PARTICULAR LIVING INDIVIDUAL.

FOR BAR SOAP; BODY AND BEAUTY CARE COSMETICS; COSMETIC PREPARATIONS; FACE, BODY AND BEAUTY CARE COSMETICS; HAIR CONDITIONER; MOUTHWASH; SHAMPOOS; SHOWER GEL; TOOTH PASTE (U.S. CLS. 1, 4, 6, 50, 51 AND 52).

MICHAEL LITZAU, EXAMINING ATTORNEY

SN 85-434,162. LAURENCE SEBEO, NEW YORK, NY. FILED 9-28-2011.

RIGGER

THE MARK CONSISTS OF STANDARD CHARACTERS WITHOUT CLAIM TO ANY PARTICULAR FONT, STYLE, SIZE, OR COLOR.

FOR PRE-MOISTENED COSMETIC WIPES; COSMETIC CREAM; LOTION FOR COSMETIC PURPOSES (U.S. CLS. 1, 4, 6, 50, 51 AND 52).

DOMINIC J. FERRAIUOLO, EXAMINING ATTORNEY

SN 85-434,833. ASILI, LLC, ANAHEIM HILLS, CA. FILED 9-28-2011.



NO CLAIM IS MADE TO THE EXCLUSIVE RIGHT TO USE "MARULA", APART FROM THE MARK AS SHOWN.

THE MARK CONSISTS OF THE WORD "MARULA" WITH TWO CIRCULAR SHAPED DESIGNS OVER THE "R" AND "U" IN "MARULA".

FOR COSMETICS MADE IN SIGNIFICANT PART OF MARULA; SKIN AND BODY CARE PRODUCTS MADE IN SIGNIFICANT PART OF MARULA, NAMELY, SOAP, BODY WASH, BODY SCRUB, BODY LOTION, BODY OIL; NON-MEDICATED HAIR CARE PREPARATIONS MADE IN SIGNIFICANT PART OF MARULA, NAMELY, SHAMPOO, CONDITIONER, HAIR REPAIR OIL (U.S. CLS. 1, 4, 6, 50, 51 AND 52).

THEODORE MCBRIDE, EXAMINING ATTORNEY

CLASS 3—(Continued).

SN 85-436,593. SPAMEDX, ROLLING HILLS, CA. FILED 9-30-2011.

Clean MD

THE MARK CONSISTS OF STANDARD CHARACTERS WITHOUT CLAIM TO ANY PARTICULAR FONT, STYLE, SIZE, OR COLOR.

NO CLAIM IS MADE TO THE EXCLUSIVE RIGHT TO USE "CLEAN", APART FROM THE MARK AS SHOWN.

FOR NON-MEDICATED LIQUID COSMETICS THAT IMPROVE THE APPEARANCE OF YOUR SKIN (U.S. CLS. 1, 4, 6, 50, 51 AND 52).

ALICE BENMAMAN, EXAMINING ATTORNEY

SN 85-439,040. SCENTISPHERE LLC, CARMEL, NY. FILED 10-4-2011.

SHOPPING SCENTER

THE MARK CONSISTS OF STANDARD CHARACTERS WITHOUT CLAIM TO ANY PARTICULAR FONT, STYLE, SIZE, OR COLOR.

FOR PRESENTED SPONGE-LIKE WAFER IN AN ENVELOPE THAT SPRAYS A MIST WHEN SQUEEZED FOR SAMPLING FRAGRANCES (U.S. CLS. 1, 4, 6, 50, 51 AND 52).

GENE MACIOL, EXAMINING ATTORNEY

CLASS 3—(Continued).

SN 85-439,645. JON MORGAN MD SKIN PRODUCTS, INC., COLUMBIA, SC. FILED 10-5-2011.

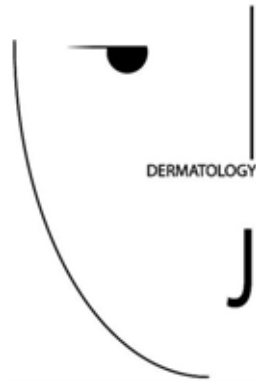

OWNER OF U.S. REG. NO. 1,626,422.
NO CLAIM IS MADE TO THE EXCLUSIVE RIGHT TO USE "DERMATOLOGY", APART FROM THE MARK AS SHOWN.

THE MARK CONSISTS OF HALF OF A STYLIZED FACE AND INCLUDES THE LETTER "J" WHERE THE MOUTH WOULD BE AND THE WORD "DERMATOLOGY" WHERE THE NOSE WOULD BE.

FOR COSMETIC CREAMS FOR SKIN CARE; COSMETIC PREPARATIONS FOR SKIN CARE; NON-MEDICATED SKIN CARE CREAMS AND LOTIONS; NON-MEDICATED SKIN CARE PREPARATIONS FOR THE TREATMENT OF NORMAL OR DAMAGED SKIN, NAMELY, TOPICAL EYE GELS, LOTIONS, CREAMS, CLEANSERS, TONICS, MOISTURIZERS, SUN SCREENS, SKIN LIGHTENERS, WRINKLE REMOVING PREPARATIONS, SHAVING CREAMS, BODY WASH, BODY SCRUBS, EXFOLIATING PREPARATIONS, TANNING CREAMS, FOUNDATION MAKEUP, CONCEALERS, MASCARA, EYE SHADOWS, LIPSTICKS, BLUSHES, AND FACE POWDERS; SKIN CARE PRODUCTS, NAMELY, NON-MEDICATED SKIN SERUM (U.S. CLS. 1, 4, 6, 50, 51 AND 52).

FIRST USE 8-1-2009; IN COMMERCE 8-1-2009.
KATHERINE CHANG, EXAMINING ATTORNEY

MIRROR IN THE WATER

THE MARK CONSISTS OF STANDARD CHARACTERS WITHOUT CLAIM TO ANY PARTICULAR FONT, STYLE, SIZE, OR COLOR.

FOR WATER-BASED COSMETIC PREPARATIONS FOR EYE CARE AND SKIN CARE (U.S. CLS. 1, 4, 6, 50, 51 AND 52).

TOBY BULLOFF, EXAMINING ATTORNEY

CLASS 3—(Continued).

SN 85-441,867. COE, JENNIFER, OJAI, CA. FILED 10-7-2011.

PLANT LAB

THE MARK CONSISTS OF STANDARD CHARACTERS WITHOUT CLAIM TO ANY PARTICULAR FONT, STYLE, SIZE, OR COLOR.

NO CLAIM IS MADE TO THE EXCLUSIVE RIGHT TO USE "PLANT", APART FROM THE MARK AS SHOWN.

FOR BODY OIL; BODY WASH; ESSENTIAL OILS; PERFUMES; SKIN SOAP (U.S. CLS. 1, 4, 6, 50, 51 AND 52).

BRIAN CALLAGHAN, EXAMINING ATTORNEY

SN 85-442,732. KMAXX GLOBAL INC., JERSEY CITY, NJ. FILED 10-7-2011.

Blue Mountain Herbals

THE MARK CONSISTS OF STANDARD CHARACTERS WITHOUT CLAIM TO ANY PARTICULAR FONT, STYLE, SIZE, OR COLOR.

NO CLAIM IS MADE TO THE EXCLUSIVE RIGHT TO USE "HERBALS", APART FROM THE MARK AS SHOWN.

FOR AFTER-SUN OILS; AROMATIC ESSENTIAL OILS; AROMATIC OILS; BATH OILS; BATH OILS AND BATH SALTS; BATH OILS FOR COSMETIC PURPOSES; BODY OILS; COSMETIC OILS FOR THE EPIDERMIS; ESSENTIAL OILS; ESSENTIAL OILS FOR AROMATHERAPY USE; ESSENTIAL OILS FOR PERSONAL USE; HAIR CARE PREPARATIONS CONSISTING OF ORGANIC COCONUT VIRGIN OIL AND COCONUT VIRGIN OIL; HAIR OILS; MASSAGE OILS; NATURAL ESSENTIAL OILS; NON-MEDICATED HERBAL BODY CARE PRODUCTS, NAMELY, BODY OILS, SALVES, AND LIP BALMS; NON-MEDICATED SKIN CREAMS WITH ESSENTIAL OILS FOR USE IN AROMATHERAPY; NUTRITIONAL OILS FOR COSMETIC PURPOSES; OILS FOR COSMETIC PURPOSES; OILS FOR TOILETRY PURPOSES; SKIN AND BODY TOPICAL LOTIONS, CREAMS AND OILS FOR COSMETIC USE (U.S. CLS. 1, 4, 6, 50, 51 AND 52).

JAMES GRIFFIN, EXAMINING ATTORNEY

CLASS 3—(Continued).

SN 85-442,760. HARP, EVERLINA LAURICE (R), DBA EVERLINA LAURICE (R), NORRISTOWN, PA. FILED 10-8-2011.

LAURICE

THE MARK CONSISTS OF STANDARD CHARACTERS WITHOUT CLAIM TO ANY PARTICULAR FONT, STYLE, SIZE, OR COLOR.

OWNER OF U.S. REG. NO. 2,160,168.

FOR CLEANING PREPARATIONS FOR JEWELRY, GEMS, EYEGLASSES, SILVERWARE AND FLATWARE; PERFUMES; AROMATIC BODY CARE PRODUCTS, NAMELY, HAIR SHAMPOO AND SOAP FOR HANDS, FACE, AND BODY; PERFUMES FOR FRAGRANCE SOAPS FOR FACE, HANDS, AND BODY (U.S. CLS. 1, 4, 6, 50, 51 AND 52).

FIRST USE 7-15-1994; IN COMMERCE 7-15-1994.

NAKIA HENRY, EXAMINING ATTORNEY

CLASS 3—(Continued).

SN 85-443,928. SHISEIDO COMPANY, LIMITED, TOKYO, JAPAN, FILED 10-11-2011.

SANTAL MAJUSCULE

THE MARK CONSISTS OF STANDARD CHARACTERS WITHOUT CLAIM TO ANY PARTICULAR FONT, STYLE, SIZE, OR COLOR.

NO CLAIM IS MADE TO THE EXCLUSIVE RIGHT TO USE "SANTAL", APART FROM THE MARK AS SHOWN.

THE ENGLISH TRANSLATION OF "SANTAL MAJUSCULE" IN THE MARK IS SANDALWOOD CAPITAL.

FOR SOAPS, PERFUMERIES, AND COSMETICS; NON-MEDICATED SKIN CARE PREPARATIONS, HAIR CARE PREPARATIONS, BODY CARE COSMETICS, AND MAKE-UP (U.S. CLS. 1, 4, 6, 50, 51 AND 52).

KATHRYN COWARD, EXAMINING ATTORNEY

SN 85-445,467. KAO KABUSHIKI KAISHA, TA KAO CORPORATION, CHUO-KU, TOKYO, JAPAN, FILED 10-12-2011.

SATIN GUARD

THE MARK CONSISTS OF STANDARD CHARACTERS WITHOUT CLAIM TO ANY PARTICULAR FONT, STYLE, SIZE, OR COLOR.

OWNER OF U.S. REG. NOS. 2,750,533 AND 2,849,775.

FOR HAIR CARE PREPARATIONS (U.S. CLS. 1, 4, 6, 50, 51 AND 52).

CORY BOONE, EXAMINING ATTORNEY

SN 85-446,011. PM TRADE CANADA, LTD, TORONTO, ONTARIO, CANADA, FILED 10-12-2011.

Elin Bianco

THE MARK CONSISTS OF STANDARD CHARACTERS WITHOUT CLAIM TO ANY PARTICULAR FONT, STYLE, SIZE, OR COLOR.

THE NAME(S), PORTRAIT(S), AND/OR SIGNATURE(S) SHOWN IN THE MARK DOES NOT IDENTIFY A PARTICULAR LIVING INDIVIDUAL.

FOR HAIR CARE LOTIONS; HAIR CREAMS; HAIR GEL AND HAIR MOUSSE; HAIR OILS; HAIR SHAMPOOS AND CONDITIONERS; HAIR TONICS; PERFUME (U.S. CLS. 1, 4, 6, 50, 51 AND 52).

CURTIS FRENCH, EXAMINING ATTORNEY

SN 85-443,249. MORTIS, MONIFA, WESTBURY, NY. FILED 10-10-2011.



THE MARK CONSISTS OF A DESIGN COMPRISED OF TWO CONCENTRIC CIRCLES CONTAINING THE LETTER "A" SURROUNDED BY A STYLIZED VINE AND CURVED LINE DESIGN.

FOR BLUSH; CONCEALERS; EYE LINER; EYE SHADOWS; EYEBROW COSMETICS; FOUNDATION MAKE-UP; LIP GLOSS; LIP LINER; LIPSTICK; LOOSE FACE POWDER; MAKE-UP REMOVER; MASCARA; SKIN BRONZER; SOLID POWDER FOR COMPACTS (U.S. CLS. 1, 4, 6, 50, 51 AND 52).

JENNIFER WILLISTON, EXAMINING ATTORNEY

CLASS 3—(Continued).

SN 85-446,368. VULT COMERCIO DE COSMETICOS LTDA.,
SAO PAULO, BRAZIL, FILED 10-13-2011.

OWNER OF BRAZIL REG. NO. 825664438, DATED 7-3-2007, EXPIRES 7-3-2017.

THE MARK CONSISTS OF THE WORD "VULT" IN STYLIZED LETTERS.

THE WORDING "VULT" HAS NO MEANING IN A FOREIGN LANGUAGE.

FOR COSMETICS; PERFUMERY (U.S. CLS. 1, 4, 6, 50, 51 AND 52).

GIANCARLO CASTRO, EXAMINING ATTORNEY

SN 85-446,653. MY BEST FOR U, LLC., NEW YORK, NY.
FILED 10-13-2011.

NENE'S MIRACLE

THE MARK CONSISTS OF STANDARD CHARACTERS WITHOUT CLAIM TO ANY PARTICULAR FONT, STYLE, SIZE, OR COLOR.

FOR HAIR CARE AND HAIR TREATMENT PREPARATIONS, NAMELY, HAIR SHAMPOO, HAIR CONDITIONERS, HAIR OILS, NON-MEDICATED HAIR BALMS, HAIR CREAMS, HAIR RINSES, HAIR LOTIONS, HAIR GELS; SKIN CARE AND SKIN TREATMENT PREPARATIONS, NAMELY, SKIN CLEANSERS, SKIN LOTIONS, SKIN CREAMS, SKIN MASKS, NON-MEDICATED SKIN GELS, EXFOLIANTS, SKIN MOISTURIZERS, SKIN SOAPS, SKIN TONERS, FACIAL SCRUBS (U.S. CLS. 1, 4, 6, 50, 51 AND 52).

AMY C. KEAN, EXAMINING ATTORNEY

CLASS 3—(Continued).

SN 85-446,870. GUINN & COMPANY, LLC, ATLANTA, GA.
FILED 10-13-2011.



THE MARK CONSISTS OF THE LETTERS "PWP" DISPLAYED WITHIN A CIRCLE IN A STYLIZED FORMAT.

FOR COSMETICS AND SKIN CARE FOR MEN AND WOMEN, NAMELY, SKIN CLEANSERS, SKIN TONERS, SKIN EXFOLIANTS, SKIN MOISTURIZERS, SKIN MASKS, EYE MAKEUP REMOVER, MAKEUP REMOVER, SUNTAN PREPARATIONS AND AFTER SUN PREPARATIONS, NAMELY, AFTER SUN LOTIONS, SUNSCREENS FOR THE FACE AND BODY, EYE SHADOW PRIMER, MASCARA PRIMER, EYE SHADOW, MASCARA, EYE LINER, EYE BROW COLOR, BLUSH, CHEEK COLOR, NAMELY, MAKEUP FOR THE CHEEK, FACE AND BODY SKIN BRONZERS; LIP PRIMER, LIP LINER, LIP STICK, LIP BALM, LIP GLOSS, FACE PRIMER, NAMELY, SKIN PRIMER IN THE NATURE OF LOTION FOR APPLYING MAKE UP, FACE FOUNDATION, FACE CONCEALER, FACE POWDER, PERFUME AND COLOGNE, BATH SALTS, BEADS AND OILS, AND AFTER-BATH SKIN MOISTURIZING OILS, GELS AND LOTIONS (U.S. CLS. 1, 4, 6, 50, 51 AND 52).

KIMBERLY PERRY, EXAMINING ATTORNEY

SN 85-447,338. JIAN W. LOU, DBA J&L SALES, ALHAMBRA, CA. FILED 10-14-2011.

P&E

THE MARK CONSISTS OF STANDARD CHARACTERS WITHOUT CLAIM TO ANY PARTICULAR FONT, STYLE, SIZE, OR COLOR.

FOR COSMETICS AND COSMETIC PREPARATIONS (U.S. CLS. 1, 4, 6, 50, 51 AND 52).

BRIDGETT SMITH, EXAMINING ATTORNEY

CLASS 3—(Continued).

SN 85-447,447. ERIK KOMUREK, DANA POINT, CA. FILED 10-14-2011.

Nocturtle

THE MARK CONSISTS OF STANDARD CHARACTERS WITHOUT CLAIM TO ANY PARTICULAR FONT, STYLE, SIZE, OR COLOR.

FOR AUTOMOTIVE CLEANING PREPARATIONS (U.S. CLS. 1, 4, 6, 50, 51 AND 52).
DANIEL CAPSHAW, EXAMINING ATTORNEY

CLASS 3—(Continued).

SN 85-447,784. MARY KAY INC., ADDISON, TX. FILED 10-14-2011.

TRULY ORIGINAL

THE MARK CONSISTS OF STANDARD CHARACTERS WITHOUT CLAIM TO ANY PARTICULAR FONT, STYLE, SIZE, OR COLOR.

FOR BATH SOAPS IN LIQUID, SOLID OR GEL FORM; BATHING LOTIONS; COLOGNE; COSMETIC PREPARATIONS FOR BATH AND SHOWER; COSMETICS; EAU DE TOILETTE; ESSENTIAL OILS FOR PERSONAL USE; FRAGRANCES FOR PERSONAL USE; HAIR CARE PREPARATIONS; LIQUID BATH SOAPS; NON-MEDICATED CLEANSERS FOR PERSONAL USE, NAMELY, BODY CLEANSERS, SKIN CLEANSERS, FACIAL CLEANSERS; NON-MEDICATED SKIN CARE PREPARATIONS; NON-MEDICATED SUN CARE PREPARATIONS; NON-MEDICATED TOILETRIES; PERFUME; SHOWER AND BATH FOAM; SHOWER AND BATH GEL; SHOWER CREAMS (U.S. CLS. 1, 4, 6, 50, 51 AND 52).

DEBORAH LOBO, EXAMINING ATTORNEY

SN 85-447,815. RECON TECHNOLOGIES LLC, GRAND RAPIDS, MI. FILED 10-14-2011.

ECALogical

THE MARK CONSISTS OF STANDARD CHARACTERS WITHOUT CLAIM TO ANY PARTICULAR FONT, STYLE, SIZE, OR COLOR.

FOR CLEANING PREPARATIONS THAT ELIMINATE BACTERIA THAT CAUSE PRODUCTS TO AGE OR PRODUCE FOUL ODORS (U.S. CLS. 1, 4, 6, 50, 51 AND 52).

ELLEN B. AWRICH, EXAMINING ATTORNEY

SN 85-447,731. FAIRICHE, LLC, SAN DIEGO, CA. FILED 10-14-2011.

FAIRICHE

THE MARK CONSISTS OF STANDARD CHARACTERS WITHOUT CLAIM TO ANY PARTICULAR FONT, STYLE, SIZE, OR COLOR.

THE WORDING "FAIRICHE" HAS NO MEANING IN A FOREIGN LANGUAGE.

FOR ANTI-AGING CLEANSER; ANTI-AGING CREAM; ANTI-AGING MOISTURIZER; ANTI-AGING TONER; BEAUTY SERUMS; BLEACHING PREPARATIONS FOR COSMETIC PURPOSES; EYE CREAM; FACIAL CLEANSERS; FACIAL MOISTURIZER WITH SPF; HAND CREAM; MOISTURIZING CREAMS; NIGHT CREAM; NON-MEDICATED ANTI-AGING SERUM; SKIN LIGHTENERS; SKIN LIGHTENING CREAMS; SUN BLOCK PREPARATIONS; TONERS (U.S. CLS. 1, 4, 6, 50, 51 AND 52).

LINDA E. BLOHM, EXAMINING ATTORNEY

SN 85-447,978. KIR, LLC, LAS VEGAS, NV. FILED 10-14-2011.



THE COLOR(S) BLUE, BROWN AND GREEN IS/ARE CLAIMED AS A FEATURE OF THE MARK.

THE MARK CONSISTS OF THE STYLIZED WORD ZEETA IN BLUE FOLLOWED BY THE ARTISTIC RENDERING OF A TREE IN BROWN AND GREEN HOLDING A GLOBE IN BLUE AND GREEN.

FOR BODY OILS, FACIAL OILS, BODY SCRUBS, FACIAL SCRUBS, FACIAL MASKS, BATH SALTS, NON-MEDICATED FOOT SOAKS (U.S. CLS. 1, 4, 6, 50, 51 AND 52).

FIRST USE 4-0-2011; IN COMMERCE 4-0-2011.

JOHN GARTNER, EXAMINING ATTORNEY

CLASS 3—(Continued).

SN 85-448,229. FERO CO LTD, MILWAUKEE, WI. FILED 10-14-2011.

SURFACE BALANCE

THE MARK CONSISTS OF STANDARD CHARACTERS WITHOUT CLAIM TO ANY PARTICULAR FONT, STYLE, SIZE, OR COLOR.

NO CLAIM IS MADE TO THE EXCLUSIVE RIGHT TO USE "SURFACE", APART FROM THE MARK AS SHOWN.

FOR SOAPS FOR CLEANING USE; ALL-PURPOSE CLEANERS; CLEANING PREPARATIONS THAT ELIMINATE BACTERIA THAT CAUSE PRODUCTS TO AGE OR PRODUCE FOUL ODORS; CLEANING PREPARATIONS; ANTI-MICROBIAL CLEANING PREPARATIONS; ANTI-FUNGAL CLEANING PREPARATIONS (U.S. CLS. 1, 4, 6, 50, 51 AND 52).

WILLIAM VERHOSEK, EXAMINING ATTORNEY



SN 85-448,235. FERO CO LTD, MILWAUKEE, WI. FILED 10-14-2011.

SURFACE BALANCE SOLUTIONS

THE MARK CONSISTS OF STANDARD CHARACTERS WITHOUT CLAIM TO ANY PARTICULAR FONT, STYLE, SIZE, OR COLOR.

NO CLAIM IS MADE TO THE EXCLUSIVE RIGHT TO USE "SURFACE" AND "SOLUTIONS", APART FROM THE MARK AS SHOWN.

FOR SOAPS FOR CLEANING USE; ALL-PURPOSE CLEANERS; CLEANING PREPARATIONS THAT ELIMINATE BACTERIA THAT CAUSE PRODUCTS TO AGE OR PRODUCE FOUL ODORS; CLEANING PREPARATIONS; ANTI-MICROBIAL CLEANING PREPARATIONS; ANTI-FUNGAL CLEANING PREPARATIONS (U.S. CLS. 1, 4, 6, 50, 51 AND 52).

WILLIAM VERHOSEK, EXAMINING ATTORNEY

CLASS 3—(Continued).

SN 85-448,249. SIMON & ANDRUSKY LLC, SAN DIEGO, CA. FILED 10-14-2011.

BELAVINE

THE MARK CONSISTS OF STANDARD CHARACTERS WITHOUT CLAIM TO ANY PARTICULAR FONT, STYLE, SIZE, OR COLOR.

THE ENGLISH TRANSLATION OF BELA IN THE MARK IS BEAUTIFUL.

FOR ANTI-AGING MOISTURIZER; BAR SOAP; BEAUTY SERUMS; BEAUTY SOAP; BODY OILS; BODY SCRUB; COSMETIC SOAPS; COSMETIC SUNSCREEN PREPARATIONS; COSMETICS; CREAM SOAPS; DEODORANTS AND ANTIPERSPIRANTS; DRY SHAMPOOS; FACIAL CLEANSERS; FACIAL MOISTURIZER WITH SPF; FACIAL SCRUBS; FOOT SCRUBS; HAIR CONDITIONER; HAIR GEL; HAIR MOUSSE; HAIR NOURISHERS; HAIR OILS; HAIR POMADES; HAIR RINSES; HAIR SHEEN SPRAY; HAIR SPRAY; HAIR STYLING PREPARATIONS; HAND SCRUBS; HAND SOAPS; LIQUID SOAP; MOISTURIZING CREAMS; MOISTURIZING PREPARATIONS FOR THE SKIN; NON-MEDICATED ANTI-AGING SERUM; NON-MEDICATED HAIR SERUMS; SHAMPOOS; SHAVING SOAP; SKIN CARE PRODUCTS, NAMELY, NON-MEDICATED SKIN SERUM; SKIN CLEANSERS; SKIN CONDITIONERS; SKIN MOISTURIZER; SKIN MOISTURIZER MASKS; SOAP IN THE FORM OF BATH TOYS; TOOTHPASTE; WATERPROOF SUNSCREEN; WIPES IMPREGNATED WITH A SKIN CLEANSER (U.S. CLS. 1, 4, 6, 50, 51 AND 52).

JENNIFER WILLISTON, EXAMINING ATTORNEY



SN 85-448,571. DEMERT BRANDS, INC., LUTZ, FL. FILED 10-17-2011.

KNOTTY TO NICE

THE MARK CONSISTS OF STANDARD CHARACTERS WITHOUT CLAIM TO ANY PARTICULAR FONT, STYLE, SIZE, OR COLOR.

FOR HAIR CARE PRODUCTS, NAMELY, DETANGLER (U.S. CLS. 1, 4, 6, 50, 51 AND 52).

THOMAS MANOR, EXAMINING ATTORNEY

CLASS 3—(Continued).

SN 85-448,587. DEMERT BRANDS, INC., LUTZ, FL. FILED 10-17-2011.

WAY TO GROW

THE MARK CONSISTS OF STANDARD CHARACTERS WITHOUT CLAIM TO ANY PARTICULAR FONT, STYLE, SIZE, OR COLOR.

FOR HAIR CARE PRODUCTS, NAMELY, SHAMPOO AND CONDITIONER (U.S. CLS. 1, 4, 6, 50, 51 AND 52).
THOMAS MANOR, EXAMINING ATTORNEY

SN 85-448,725. VICTORIA'S SECRET STORES BRAND MANAGEMENT, INC., REYNOLDSBURG, OH. FILED 10-17-2011.

TOUCH OF MYSTERY

THE MARK CONSISTS OF STANDARD CHARACTERS WITHOUT CLAIM TO ANY PARTICULAR FONT, STYLE, SIZE, OR COLOR.

FOR BODY CREAM; BODY LOTION; BODY SCRUB; BODY WASH; EAU DE PARFUM; NON-MEDICATED SKIN CARE PREPARATION, NAMELY, BODY MIST (U.S. CLS. 1, 4, 6, 50, 51 AND 52).
MICHAEL LITZAU, EXAMINING ATTORNEY

SN 85-448,733. VICTORIA'S SECRET STORES BRAND MANAGEMENT, INC., REYNOLDSBURG, OH. FILED 10-17-2011.

ESCAPE WITH ME

THE MARK CONSISTS OF STANDARD CHARACTERS WITHOUT CLAIM TO ANY PARTICULAR FONT, STYLE, SIZE, OR COLOR.

FOR BODY CREAM; BODY LOTION; BODY SCRUB; BODY WASH; EAU DE PARFUM; NON-MEDICATED SKIN CARE PREPARATION, NAMELY, BODY MIST (U.S. CLS. 1, 4, 6, 50, 51 AND 52).
MICHAEL LITZAU, EXAMINING ATTORNEY

CLASS 3—(Continued).

SN 85-448,762. SAM LAM, M.D., PLANO, TX. FILED 10-17-2011.

OVA

THE MARK CONSISTS OF STANDARD CHARACTERS WITHOUT CLAIM TO ANY PARTICULAR FONT, STYLE, SIZE, OR COLOR.

FOR FACIAL CLEANSERS; FACIAL CREAMS; FACIAL LOTION; FACIAL WASHES (U.S. CLS. 1, 4, 6, 50, 51 AND 52).

WENDY JUN, EXAMINING ATTORNEY

SN 85-449,133. HYPOLUXE, INC., ORLANDO, CA. FILED 10-17-2011.

PERFUMEO

THE MARK CONSISTS OF STANDARD CHARACTERS WITHOUT CLAIM TO ANY PARTICULAR FONT, STYLE, SIZE, OR COLOR.

FOR AFTERSHAVE; COLOGNE; EAU DE PARFUM; EAU DE TOILETTE; FRAGRANCES; PERFUME (U.S. CLS. 1, 4, 6, 50, 51 AND 52).
SUNG IN, EXAMINING ATTORNEY

SN 85-449,135. HYPOLUXE, INC., ORLANDO, FL. FILED 10-17-2011.

ANTIMATTER

THE MARK CONSISTS OF STANDARD CHARACTERS WITHOUT CLAIM TO ANY PARTICULAR FONT, STYLE, SIZE, OR COLOR.

FOR AFTERSHAVE; COLOGNE; EAU DE PARFUM; EAU DE TOILETTE; FRAGRANCES; PERFUME (U.S. CLS. 1, 4, 6, 50, 51 AND 52).

SUNG IN, EXAMINING ATTORNEY

CLASS 3—(Continued).

SN 85-449,244. VILLANO, MARIE, HOPKINS, MN. AND VILLANO, LAWRENCE, HOPKINS, MN. FILED 10-17-2011.

KangaEnergy

THE MARK CONSISTS OF STANDARD CHARACTERS WITHOUT CLAIM TO ANY PARTICULAR FONT, STYLE, SIZE, OR COLOR.

FOR INHALER SOLD FILLED WITH ESSENTIAL OILS FOR USE IN AROMATHERAPY (U.S. CLS. 1, 4, 6, 50, 51 AND 52).

AMY HELLA, EXAMINING ATTORNEY

CLASS 3—(Continued).

SN 85-449,913. KISS MY FACE, LLC, LOS ANGELES, CA. FILED 10-18-2011.

ACTIVE LIFE

THE MARK CONSISTS OF STANDARD CHARACTERS WITHOUT CLAIM TO ANY PARTICULAR FONT, STYLE, SIZE, OR COLOR.

FOR PERSONAL DEODORANTS (U.S. CLS. 1, 4, 6, 50, 51 AND 52).

FIRST USE 5-5-2011; IN COMMERCE 5-5-2011.

JEFFREY LOOK, EXAMINING ATTORNEY

SN 85-449,415. OPMX, LLC, CHICAGO, IL. FILED 10-18-2011.

Rejuveina

THE MARK CONSISTS OF STANDARD CHARACTERS WITHOUT CLAIM TO ANY PARTICULAR FONT, STYLE, SIZE, OR COLOR.

FOR ANTI-AGING CREAMS; ANTI-WRINKLE CREAMS; BEAUTY CREAMS FOR BODY CARE; CLEANSING CREAMS; COSMETIC CREAMS; COSMETIC PREPARATIONS FOR SKIN CARE; EYE CREAM; FACIAL CREAM; SKIN LIGHTENING CREAMS; SKIN WHITENING CREAMS (U.S. CLS. 1, 4, 6, 50, 51 AND 52).

STEVEN PEREZ, EXAMINING ATTORNEY

SN 85-450,126. NATURAL THOUGHTS, INC., DBA BIOTONE, SAN DIEGO, CA. FILED 10-18-2011.

TRUE BALANCE

THE MARK CONSISTS OF STANDARD CHARACTERS WITHOUT CLAIM TO ANY PARTICULAR FONT, STYLE, SIZE, OR COLOR.

FOR MASSAGE OIL (U.S. CLS. 1, 4, 6, 50, 51 AND 52).

JOHN GARTNER, EXAMINING ATTORNEY

SN 85-449,512. BIO-2, INC, LIVERPOOL, TX. FILED 10-18-2011.

derm02

THE MARK CONSISTS OF STANDARD CHARACTERS WITHOUT CLAIM TO ANY PARTICULAR FONT, STYLE, SIZE, OR COLOR.

FOR BODY AND BEAUTY CARE COSMETICS (U.S. CLS. 1, 4, 6, 50, 51 AND 52).

DANIEL CAPSHAW, EXAMINING ATTORNEY

SN 85-450,248. SATISLOH NORTH AMERICA, INC., GERMANTOWN, WI. FILED 10-18-2011.

DIGI-PRO

THE MARK CONSISTS OF STANDARD CHARACTERS WITHOUT CLAIM TO ANY PARTICULAR FONT, STYLE, SIZE, OR COLOR.

FOR LENS POLISH FOR THE OPHTHALMIC LENS INDUSTRY (U.S. CLS. 1, 4, 6, 50, 51 AND 52).

SALLY SHIH, EXAMINING ATTORNEY

CLASS 3—(Continued).

SN 85-450,438. APOLLO DR CONSULTANT LLC, MIAMI, FL. FILED 10-18-2011.

LIFTINGOLD

THE MARK CONSISTS OF STANDARD CHARACTERS WITHOUT CLAIM TO ANY PARTICULAR FONT, STYLE, SIZE, OR COLOR.

FOR NON-MEDICATED SERUMS FOR USE ON SKIN (U.S. CLS. 1, 4, 6, 50, 51 AND 52).
FIRST USE 9-1-2011; IN COMMERCE 9-1-2011.
ANTHONY RINKER, EXAMINING ATTORNEY

SN 85-450,495. MCCAIN, SHAWN M, MURRIETA, CA. FILED 10-18-2011.

Cymbal Shield

THE MARK CONSISTS OF STANDARD CHARACTERS WITHOUT CLAIM TO ANY PARTICULAR FONT, STYLE, SIZE, OR COLOR.

NO CLAIM IS MADE TO THE EXCLUSIVE RIGHT TO USE "CYMBAL", APART FROM THE MARK AS SHOWN.
FOR POLISH FOR MUSICAL INSTRUMENTS (U.S. CLS. 1, 4, 6, 50, 51 AND 52).
JOHN DWYER, EXAMINING ATTORNEY

SN 85-450,589. SHISEIDO COMPANY, LIMITED, TOKYO, JAPAN, FILED 10-19-2011.

LEVRES EN BOITE

THE MARK CONSISTS OF STANDARD CHARACTERS WITHOUT CLAIM TO ANY PARTICULAR FONT, STYLE, SIZE, OR COLOR.

THE ENGLISH TRANSLATION OF "LEVRES EN BOITE" IS "LIPS IN BOX".

FOR SOAPS, PERFUMERIES, AND COSMETICS; NON-MEDICATED SKIN CARE PREPARATIONS, HAIR CARE PREPARATIONS, BODY CARE COSMETICS, AND MAKE-UP (U.S. CLS. 1, 4, 6, 50, 51 AND 52).
KATHRYN COWARD, EXAMINING ATTORNEY

CLASS 3—(Continued).

SN 85-450,656. AVAX MEDIA, LLC, WINTER HAVEN, FL. FILED 10-19-2011.

BLUE BALM

THE MARK CONSISTS OF STANDARD CHARACTERS WITHOUT CLAIM TO ANY PARTICULAR FONT, STYLE, SIZE, OR COLOR.

NO CLAIM IS MADE TO THE EXCLUSIVE RIGHT TO USE "BALM", APART FROM THE MARK AS SHOWN.

SEC. 2(F).
FOR BAR SOAP; LIQUID SOAPS; SHAMPOOS (U.S. CLS. 1, 4, 6, 50, 51 AND 52).
FIRST USE 0-0-1996; IN COMMERCE 0-0-1996.
CHRISTINA SOBRAL, EXAMINING ATTORNEY

SN 85-451,535. COOK, TERRACE W, TROUTDALE, OR. FILED 10-19-2011.

Twice Cleansed

THE MARK CONSISTS OF STANDARD CHARACTERS WITHOUT CLAIM TO ANY PARTICULAR FONT, STYLE, SIZE, OR COLOR.

FOR HANDMADE SOAP BARS (U.S. CLS. 1, 4, 6, 50, 51 AND 52).

THEODORE MCBRIDE, EXAMINING ATTORNEY

SN 85-452,689. TWENTIETH CENTURY FOX FILM CORPORATION, LOS ANGELES, CA. FILED 10-20-2011.

CON GARRA

THE MARK CONSISTS OF STANDARD CHARACTERS WITHOUT CLAIM TO ANY PARTICULAR FONT, STYLE, SIZE, OR COLOR.

THE ENGLISH TRANSLATION OF "CON GARRA" IN THE MARK IS "PUNCHY".

FOR BATH SOAPS; HAND SOAPS; LIQUID SOAPS; DETERGENTS FOR HOUSEHOLD USE; HAIR SHAMPOOS AND CONDITIONERS; SHOWER AND BATH GEL; PERFUMES AND COLOGNES; EAU DE TOILETTE; LIP BALM; TOOTHPASTE AND MOUTHWASHES; BUBBLE BATH; BATH OIL AND BATH SALTS; BATH POWDER; LOTIONS FOR SKIN, HAIR, FACE AND BODY; FACE AND BODY CREAM; HAIR CREAM; HAND CREAM; SUNSCREEN CREAM; SUNTAN CREAM; BODY SPRAY; HAIR SPRAY AND HAIR GEL; SCENTED ROOM SPRAYS; BODY AND BEAUTY CARE COSMETICS; MASSAGE CREAM; MASSAGE LOTION; MASSAGE OIL; SHAVING CREAM; SHAVING FOAM; SHAVING GEL; SHAVING LOTION; SHAVING SOAP (U.S. CLS. 1, 4, 6, 50, 51 AND 52).

JANICE L. MCMORROW, EXAMINING ATTORNEY

CLASS 3—(Continued).

SN 85-453,456. NABILAK LLC, SALT LAKE CITY, UT. FILED 10-21-2011.



NABILA K

THE NAME "NABILA" IDENTIFIES A LIVING INDIVIDUAL WHOSE CONSENT IS OF RECORD.

THE MARK CONSISTS OF THE LETTERS "NK" INSIDE A SQUARE DESIGN WITH THE WORD "NABILA K" UNDERNEATH.

FOR BATH OILS (U.S. CLS. 1, 4, 6, 50, 51 AND 52).
MARGERY A. TIERNEY, EXAMINING ATTORNEY

SN 85-455,125. VICTORIA'S SECRET STORES BRAND MANAGEMENT, INC., REYNOLDSBURG, OH. FILED 10-25-2011.

MOONLIGHT DREAM

THE MARK CONSISTS OF STANDARD CHARACTERS WITHOUT CLAIM TO ANY PARTICULAR FONT, STYLE, SIZE, OR COLOR.

FOR BODY CREAM; BODY LOTION; BODY SCRUB; BODY WASH; EAU DE PARFUM; EAU DE TOILETTE; NON-MEDICATED SKIN CARE PREPARATION, NAMELY, BODY MIST (U.S. CLS. 1, 4, 6, 50, 51 AND 52).
MICHAEL LITZAU, EXAMINING ATTORNEY

SN 85-456,918. ARCANATURA LLC, GROTON, CT. FILED 10-26-2011.

Scratches Less Resolution

THE MARK CONSISTS OF STANDARD CHARACTERS WITHOUT CLAIM TO ANY PARTICULAR FONT, STYLE, SIZE, OR COLOR.

NO CLAIM IS MADE TO THE EXCLUSIVE RIGHT TO USE "SCRATCHES LESS", APART FROM THE MARK AS SHOWN.

FOR NON-MEDICATED SKIN CREAMS FOR ANIMALS (U.S. CLS. 1, 4, 6, 50, 51 AND 52).
ADA HAN, EXAMINING ATTORNEY

CLASS 3—(Continued).

SN 85-464,417. AUSTRALIAN GOLD, LLC, INDIANAPOLIS, IN. FILED 11-4-2011.

CLEANTOUCH

THE MARK CONSISTS OF STANDARD CHARACTERS WITHOUT CLAIM TO ANY PARTICULAR FONT, STYLE, SIZE, OR COLOR.

FOR INDOOR AND OUTDOOR NON-MEDICATED SKIN TANNING PREPARATIONS (U.S. CLS. 1, 4, 6, 50, 51 AND 52).

EDWARD FENNESSY, EXAMINING ATTORNEY

SN 85-466,987. MARY KAY INC., DALLAS, TX. FILED 11-8-2011.

ENDLESS PERFORMANCE

THE MARK CONSISTS OF STANDARD CHARACTERS WITHOUT CLAIM TO ANY PARTICULAR FONT, STYLE, SIZE, OR COLOR.

OWNER OF U.S. REG. NO. 3,012,680.

FOR BATH LOTION; BATH SOAPS IN LIQUID, SOLID OR GEL FORM; COLOGNE; COSMETIC PREPARATIONS FOR BATH AND SHOWER; COSMETICS; EAU DE TOILETTE AND EAU DE COLOGNE; ESSENTIAL OILS FOR PERSONAL USE; FRAGRANCES FOR PERSONAL USE; LIP BALM; LIP CREAM; LIP GLOSS; LIP LINER; LIPSTICKS; NON-MEDICATED SKIN CARE PREPARATIONS; NON-MEDICATED TOILETRIES; SHOWER AND BATH GEL; SHOWER CREAMS (U.S. CLS. 1, 4, 6, 50, 51 AND 52).

DEBORAH LOBO, EXAMINING ATTORNEY

SN 85-480,714. WRIGHT, BRUCE DAVID, SARASOTA, FL. FILED 11-24-2011.

BIO bodi

THE MARK CONSISTS OF STANDARD CHARACTERS WITHOUT CLAIM TO ANY PARTICULAR FONT, STYLE, SIZE, OR COLOR.

NO CLAIM IS MADE TO THE EXCLUSIVE RIGHT TO USE "BODY", APART FROM THE MARK AS SHOWN.

FOR NON-MEDICATED SKIN CARE PREPARATIONS (U.S. CLS. 1, 4, 6, 50, 51 AND 52).

DEZMONA MIZELLE, EXAMINING ATTORNEY

CLASS 3—(Continued).

SN 85-482,934. SALVATION, LLC, TUSCON, AZ. FILED 11-29-2011.

JAMES CHRISTIANMAN

THE MARK CONSISTS OF STANDARD CHARACTERS WITHOUT CLAIM TO ANY PARTICULAR FONT, STYLE, SIZE, OR COLOR.

OWNER OF U.S. REG. NOS. 3,946,463 AND 4,091,660.
 THE NAME "JAMES CHRISTIANMAN" DOES NOT IDENTIFY A LIVING INDIVIDUAL.
 FOR COLOGNE, BODY LOTION, AFTERSHAVE (U.S. CLS. 1, 4, 6, 50, 51 AND 52).
 FIRST USE 12-1-2010; IN COMMERCE 12-1-2010.
 ELLEN BURNS, EXAMINING ATTORNEY

CLASS 3—(Continued).

SN 85-499,881. GUCCI AMERICA, INC., NEW YORK, NY. FILED 12-20-2011.



OWNER OF U.S. REG. NOS. 1,106,722, 3,378,755 AND OTHERS.

THE MARK CONSISTS OF A REPEATING PATTERN OF THE STYLIZED LETTERS "GG" SURROUNDED BY FOUR FILLED SQUARES AT FOUR CORNERS OF THE LETTERS, FORMING AN OVERALL DIAMOND DESIGN PATTERN.
 FOR COSMETICS (U.S. CLS. 1, 4, 6, 50, 51 AND 52).
 DAWN HAN, EXAMINING ATTORNEY

SN 85-493,090. NINE WEST DEVELOPMENT CORPORATION, WILMINGTON, DE. FILED 12-12-2011.



THE MARK CONSISTS OF THE WORD "LOVE" IN LOWER CASE CURSIVE APPEARING OVER THE WORD "FURY" IN LOWER CASE CURSIVE.

FOR COLOGNE; COSMETICS (U.S. CLS. 1, 4, 6, 50, 51 AND 52).
 GRETTA YAO, EXAMINING ATTORNEY

SN 85-499,940. GUCCI AMERICA, INC., NEW YORK, NY. FILED 12-20-2011.



OWNER OF U.S. REG. NOS. 1,106,722, 3,378,755 AND OTHERS.

THE MARK CONSISTS OF THE STYLIZED LETTERS "GG" SURROUNDED BY FOUR FILLED SQUARES AT FOUR CORNERS OF THE LETTERS.
 FOR COSMETICS (U.S. CLS. 1, 4, 6, 50, 51 AND 52).
 DAWN HAN, EXAMINING ATTORNEY

CLASS 3—(Continued).

SN 85-511,755. DAI ENTERPRISES LLC, BEVERLY HILLS, CA. FILED 1-9-2012.

TAYA

THE MARK CONSISTS OF STANDARD CHARACTERS WITHOUT CLAIM TO ANY PARTICULAR FONT, STYLE, SIZE, OR COLOR.

OWNER OF U.S. REG. NO. 3,860,651.

FOR HAIR CARE PRODUCTS, NAMELY, SHAMPOO, CONDITIONERS, HAIR SPRAY, STYLING GELS, AND MOUSSE; NON-MEDICATED SKIN CARE PREPARATIONS, NAMELY, LOTIONS, GELS, AND CREAMS FOR THE FACE AND BODY (U.S. CLS. 1, 4, 6, 50, 51 AND 52).

FIRST USE 3-4-2010; IN COMMERCE 3-4-2010.
APRIL ROACH, EXAMINING ATTORNEY

CLASS 4—LUBRICANTS AND FUELS

SN 85-329,805. CHOCOLAT SKIN CARE, INC., NEW CITY, NY. FILED 5-25-2011.



THE COLOR(S) GREEN, YELLOW, DARK BROWN, RED, BLACK, LIGHT CHOCOLATE AND DARK CHOCOLATE IS/ ARE CLAIMED AS A FEATURE OF THE MARK.

THE MARK CONSISTS OF A GREEN, YELLOW, DARK BROWN, AND RED SQUARE IN A BOX, EACH COLOR BORDERED IN BLACK, ALONGSIDE THE WORD "CHOCOLAT" (WITH AN UMLAUT OVER THE "A"), THE WORD BEING A LIGHT CHOCOLATE COLOR AND THE UMLAUT BEING A DARK CHOCOLATE COLOR.

THE ENGLISH TRANSLATION OF "CHOCOLAT" IN THE MARK IS "CHOCOLATE".

FOR CANDLES (U.S. CLS. 1, 6 AND 15).

FIRST USE 9-29-2010; IN COMMERCE 9-29-2010.

MICHAEL ENGEL, EXAMINING ATTORNEY

SN 85-433,039. WASTE MANAGEMENT, INC., HOUSTON, TX. FILED 9-27-2011.

SPECFUEL

THE MARK CONSISTS OF STANDARD CHARACTERS WITHOUT CLAIM TO ANY PARTICULAR FONT, STYLE, SIZE, OR COLOR.

FOR FUELS, NAMELY, PROCESS ENGINEERED FUEL (U.S. CLS. 1, 6 AND 15).

PAUL MORENO, EXAMINING ATTORNEY

SN 85-514,013. MY BEST FOR U, LLC., NEW YORK, NY. FILED 1-11-2012.

GORGEOUS GRO

THE MARK CONSISTS OF STANDARD CHARACTERS WITHOUT CLAIM TO ANY PARTICULAR FONT, STYLE, SIZE, OR COLOR.

FOR HAIR CARE AND HAIR TREATMENT PREPARATIONS, NAMELY, HAIR SHAMPOO, HAIR CONDITIONERS, HAIR OILS, NON-MEDICATED HAIR BALMS, HAIR CREAMS, HAIR RINSES, HAIR LOTIONS, HAIR GELS; SKIN CARE AND SKIN TREATMENT PREPARATIONS, NAMELY, SKIN CLEANSERS, SKIN LOTIONS, SKIN CREAMS, SKIN MASKS, NON-MEDICATED SKIN GELS, EXFOLIANTS, SKIN MOISTURIZERS, SKIN SOAPS, SKIN TONERS, FACIAL SCRUBS (U.S. CLS. 1, 4, 6, 50, 51 AND 52).

AMY C. KEAN, EXAMINING ATTORNEY

SN 85-446,473. MILPACK VENTURES LLC, TAMPA, FL. FILED 10-13-2011.

UTILITY FLAME

THE MARK CONSISTS OF STANDARD CHARACTERS WITHOUT CLAIM TO ANY PARTICULAR FONT, STYLE, SIZE, OR COLOR.

FOR GELLED FUEL (U.S. CLS. 1, 6 AND 15).

DAVID MURRAY, EXAMINING ATTORNEY

CLASS 4—(Continued).

SN 85-447,107. ACCELERGY CORPORATION, HOUSTON, TX. FILED 10-13-2011.

TERRASYNC

THE MARK CONSISTS OF STANDARD CHARACTERS WITHOUT CLAIM TO ANY PARTICULAR FONT, STYLE, SIZE, OR COLOR.

FOR SYNTHETIC LIQUID FUELS (U.S. CLS. 1, 6 AND 15).

RON FAIRBANKS, EXAMINING ATTORNEY

CLASS 5—PHARMACEUTICALS

SN 76-707,188. OLDE GRANDDAD INDUSTRIES, INC., KEARNY, NJ. FILED 4-8-2011.

PUMA

THE MARK CONSISTS OF STANDARD CHARACTERS WITHOUT CLAIM TO ANY PARTICULAR FONT, STYLE, SIZE, OR COLOR.

FOR FRAGRANCE AND DEODORIZING PRODUCTS FOR LAND VEHICLES, AIRCRAFT, WATERCRAFT, PERSONAL, COMMERCIAL, INDUSTRIAL AND HOME USE, NAMELY, AIR FRESHENERS AND DEODORIZERS (U.S. CLS. 6, 18, 44, 46, 51 AND 52).

CURTIS FRENCH, EXAMINING ATTORNEY

SN 76-708,851. IGNITE NATURALS, INC., LAS VEGAS, NV. FILED 8-25-2011.

POWER CLIP

THE MARK CONSISTS OF STANDARD CHARACTERS WITHOUT CLAIM TO ANY PARTICULAR FONT, STYLE, SIZE, OR COLOR.

NO CLAIM IS MADE TO THE EXCLUSIVE RIGHT TO USE "CLIP", APART FROM THE MARK AS SHOWN.

FOR ORALLY INGESTED GEL FOR BOOSTING ENERGY IN PACKET FORM, WHICH HOOKS DIRECTLY ONTO A BELT OR GEAR (U.S. CLS. 6, 18, 44, 46, 51 AND 52).

ALICIA COLLINS, EXAMINING ATTORNEY

CLASS 5—(Continued).

SN 77-466,933. VITABALL, INC., FT. THOMAS, KY. FILED 5-6-2008.

SmartGum vitamimum

THE MARK CONSISTS OF STANDARD CHARACTERS WITHOUT CLAIM TO ANY PARTICULAR FONT, STYLE, SIZE, OR COLOR.

NO CLAIM IS MADE TO THE EXCLUSIVE RIGHT TO USE "VITAMIN GUM", APART FROM THE MARK AS SHOWN.

FOR VITAMIN FORTIFIED CHEWING GUM (U.S. CLS. 6, 18, 44, 46, 51 AND 52).

TINA L. SNAPP, EXAMINING ATTORNEY

SN 77-515,516. GENENEWS LIMITED, RICHMOND HILL, CANADA, FILED 7-7-2008.



PRIORITY CLAIMED UNDER SEC. 44(D) ON CANADA APPLICATION NO. 1400377, FILED 6-19-2008, REG. NO. TMA815305, DATED 1-11-2012, EXPIRES 1-11-2017.

FOR DIAGNOSTIC KITS COMPRISING MOLECULAR BIOLOGICAL REAGENTS USEFUL FOR DETECTING GENE EXPRESSION PRODUCTS, NAMELY, RIBONUCLEIC ACID (RNA) OR PROTEINS, AS AN INDICATION OF BODY STATE, NAMELY, HEALTH, CONDITION, DISEASE OR RESPONSE TO THERAPEUTIC TREATMENT (U.S. CLS. 6, 18, 44, 46, 51 AND 52).

MARGERIE A. TIERNEY, EXAMINING ATTORNEY

CLASS 5—(Continued).

SN 77-543,793. INSTITUT ROSELL INC., MONTREAL, QUEBEC, CANADA, FILED 8-11-2008.

PROBIOKID

THE MARK CONSISTS OF STANDARD CHARACTERS WITHOUT CLAIM TO ANY PARTICULAR FONT, STYLE, SIZE, OR COLOR.

FOR BACTERIAL PREPARATIONS FOR MEDICAL OR PHARMACEUTICAL USE, FOOD SUPPLEMENTS FOR MEDICAL PURPOSES (U.S. CLS. 6, 18, 44, 46, 51 AND 52).

FIRST USE 11-30-2007; IN COMMERCE 11-30-2007.
AISHA SALEM, EXAMINING ATTORNEY

SN 77-617,570. AMATO, TERI, BAYSIDE, NY. FILED 11-19-2008.

LIPLOV

THE MARK CONSISTS OF STANDARD CHARACTERS WITHOUT CLAIM TO ANY PARTICULAR FONT, STYLE, SIZE, OR COLOR.

FOR NATURAL TOPICAL FORMULATION FOR SEXUAL ENHANCEMENT, NAMELY, PERSONAL LUBRICANT (U.S. CLS. 6, 18, 44, 46, 51 AND 52).

TOBY BULLOFF, EXAMINING ATTORNEY

CLASS 5—(Continued).

SN 79-096,886. BIOFRONTERA AG, FED REP GERMANY, FILED 4-6-2011.



PRIORITY DATE OF 10-21-2010 IS CLAIMED.

OWNER OF INTERNATIONAL REGISTRATION 1075749 DATED 4-6-2011, EXPIRES 4-6-2021.

OWNER OF U.S. REG. NOS. 2,445,524 AND 3,508,876.

THE MARK CONSISTS OF THE TERM "BIOFRONTERA" WITH A DESIGN OF A CIRCLE AND CURVED LINES ENCIRCLING THE CIRCLE EXCEPT FOR THE AREA WHERE THE LETTER "A" APPEARS IN THE TERM "BIOFRONTERA".

FOR PHARMACEUTICAL AND VETERINARY PREPARATIONS, NAMELY, FOR THE TREATMENT OF MIGRAINES, CANCER, DERMATOLOGIC DISORDERS AND GYNAECOLOGICAL DISORDERS; VETERINARY PREPARATIONS FOR THE TREATMENT OF CANCER, DERMATOLOGIC DISORDERS AND GYNAECOLOGICAL DISORDERS; SANITARY PREPARATIONS FOR MEDICAL PURPOSES; PREPARATIONS FOR DESTROYING VERMIN; FUNGICIDES, HERBICIDES; ACARICIDES FOR AGRICULTURAL USE, AGRICULTURAL BIOPESTICIDES, AGRICULTURAL PESTICIDES; BACTERIOLOGICAL PREPARATIONS FOR MEDICAL AND VETERINARY USE; BIOLOGICAL PREPARATIONS FOR MEDICAL PURPOSES; BIOLOGICAL PREPARATIONS FOR VETERINARY PURPOSES; BIOCHEMICAL PREPARATIONS FOR MEDICAL AND VETERINARY PURPOSES; ENZYMES FOR MEDICAL PURPOSES; ENZYMES FOR VETERINARY PURPOSES; ENZYME PREPARATIONS FOR MEDICAL AND VETERINARY PURPOSES; FERMENTS FOR PHARMACEUTICAL PURPOSES; VACCINES; PREPARATIONS FOR MIGRAINES; NUTRITIVE SUBSTANCES FOR MICROORGANISMS; PLASTERS FOR MEDICAL PURPOSES; VESICANT AGENTS FOR MEDICAL USE; DIAGNOSTIC PREPARATIONS FOR MEDICAL PURPOSES; CHEMICAL PREPARATIONS FOR MEDICAL PURPOSES, NAMELY, CHEMICAL REAGENTS FOR MEDICAL PURPOSES; CHEMICAL PREPARATIONS FOR PHARMACEUTICAL PURPOSES, NAMELY, PHARMACEUTICAL PREPARATIONS FOR USE IN CHEMOTHERAPY, AND CHEMICAL REAGENTS FOR MEDICAL PURPOSES; CHEMICAL PREPARATIONS FOR VETERINARY PURPOSES, NAMELY, CHEMICAL REAGENTS FOR VETERINARY PURPOSES; MEDICINES FOR HUMAN PURPOSES, NAMELY, MEDICINES FOR THE TREATMENT OF GASTROINTESTINAL DISEASES, MIGRAINES, CANCER, DERMATOLOGIC DISORDERS AND GYNAECOLOGICAL DISORDERS; MEDICINES FOR VETERINARY PURPOSES, NAMELY, MEDICINE FOR THE TREATMENT OF MIGRAINES, CANCER, DERMATOLOGIC DISORDERS AND GYNAECOLOGICAL DISORDERS, GASTROINTESTINAL DISEASES; MEDICINES FOR DENTAL PURPOSES, NAMELY, BACTERIOSTATS FOR MEDICINAL AND DENTAL USE, MEDICINAL PREPARATIONS FOR THE MOUTH AND AS SPRAYS (U.S. CLS. 6, 18, 44, 46, 51 AND 52).

CHRISTOPHER BUONGIORNO, EXAMINING ATTORNEY

CLASS 5—(Continued).

SN 79-107,398. KONINKLIJKE PHILIPS ELECTRONICS N.V., NETHERLANDS, FILED 11-7-2011.

TADIM

THE MARK CONSISTS OF STANDARD CHARACTERS WITHOUT CLAIM TO ANY PARTICULAR FONT, STYLE, SIZE, OR COLOR.

PRIORITY DATE OF 5-13-2011 IS CLAIMED.

OWNER OF INTERNATIONAL REGISTRATION 1102256 DATED 11-7-2011, EXPIRES 11-7-2021.

FOR ANTIBIOTIC PREPARATIONS AND ANTIBIOTIC SUBSTANCES, INCLUDING LIQUID ANTIBIOTICS, TO FIGHT AND PREVENT INFECTIONS OF THE LUNGS (U.S. CLS. 6, 18, 44, 46, 51 AND 52).

KRISTINA MORRIS, EXAMINING ATTORNEY

CLASS 5—(Continued).

SN 85-158,999. SCA HYGIENE PRODUCTS AB, GOTEBORG, SWEDEN, FILED 10-22-2010.

SABA CONFORT

THE MARK CONSISTS OF STANDARD CHARACTERS WITHOUT CLAIM TO ANY PARTICULAR FONT, STYLE, SIZE, OR COLOR.

NO CLAIM IS MADE TO THE EXCLUSIVE RIGHT TO USE "CONFORT", APART FROM THE MARK AS SHOWN. THE ENGLISH TRANSLATION OF THE WORD "CONFORT" IN THE MARK IS COMFORT.

FOR SANITARY TOWELS, PANTYLINERS, SANITARY NAPKINS, TAMPONS (U.S. CLS. 6, 18, 44, 46, 51 AND 52).

LESLEY LAMOTHE, EXAMINING ATTORNEY

SN 85-134,189. FRUIT CHILL, INC., LINCOLNWOOD, IL. FILED 9-21-2010.



NO CLAIM IS MADE TO THE EXCLUSIVE RIGHT TO USE "ORGANICK", APART FROM THE MARK AS SHOWN.

THE MARK CONSISTS OF THE TERMS "ORGANICK LIFE" TO THE RIGHT OF A ROUNDING ARROW THAT FORMS A SPHERE IN PLACE OF THE LETTER "O" IN "ORGANICK" AND WITH A LEAF IN PLACE OF THE DOT THAT FORMS THE "I" IN THE WORD "LIFE".

FOR ORGANIC FOOD SUPPLEMENTS (U.S. CLS. 6, 18, 44, 46, 51 AND 52).

LINDA MICKLEBURGH, EXAMINING ATTORNEY

SN 85-167,911. JOHANNSEN NUTRACEUTICALS, LLC, LOS ANGELES, CA. FILED 11-3-2010.



THE MARK CONSISTS OF THE STYLIZED TEXT "STAMINAZ" TO THE LEFT OF A DESIGN CONSISTING OF A SQUARE WITH SWIRLING LINES.

FOR VITAMIN SUPPLEMENTS (U.S. CLS. 6, 18, 44, 46, 51 AND 52).

ANDREA HACK, EXAMINING ATTORNEY

SN 85-141,102. BIOFARMA, SURESNES CEDEX, FRANCE, FILED 9-29-2010.

VALDEFY

THE MARK CONSISTS OF STANDARD CHARACTERS WITHOUT CLAIM TO ANY PARTICULAR FONT, STYLE, SIZE, OR COLOR.

PRIORITY CLAIMED UNDER SEC. 44(D) ON FRANCE APPLICATION NO. 103768700, FILED 9-23-2010, REG. NO. 103768700, DATED 9-23-2010, EXPIRES 9-23-2020.

THE WORDING "VALDEFY" HAS NO MEANING IN A FOREIGN LANGUAGE.

FOR PHARMACEUTICAL PREPARATIONS FOR DISEASES OF THE CENTRAL NERVOUS SYSTEM; ANTI-DEPRESSIVES (U.S. CLS. 6, 18, 44, 46, 51 AND 52).

MICHAEL KEATING, EXAMINING ATTORNEY

SN 85-195,236. WHEELER, KENNETH, MORGAN HILL, CA. FILED 12-10-2010.

Flex Wheeler

THE MARK CONSISTS OF STANDARD CHARACTERS WITHOUT CLAIM TO ANY PARTICULAR FONT, STYLE, SIZE, OR COLOR.

THE NAME(S), PORTRAIT(S), AND/OR SIGNATURE(S) SHOWN IN THE MARK IDENTIFIES KENNETH "WHEELER", WHOSE CONSENT(S) TO REGISTER IS MADE OF RECORD.

FOR DIETARY AND NUTRITIONAL SUPPLEMENTS (U.S. CLS. 6, 18, 44, 46, 51 AND 52).

FIRST USE 5-1-1989; IN COMMERCE 8-1-1992.

WANDA KAY PRICE, EXAMINING ATTORNEY

CLASS 5—(Continued).

SN 85-234,452. THE ORIGINAL BROOKLYN WATER BOTTLING CO., INC., BOCA RATON, FL. FILED 2-4-2011.

THE ORIGINAL BROOKLYN
WATER BOTTLING COMPANY

THE MARK CONSISTS OF STANDARD CHARACTERS WITHOUT CLAIM TO ANY PARTICULAR FONT, STYLE, SIZE, OR COLOR.

OWNER OF U.S. REG. NO. 4,014,959.
NO CLAIM IS MADE TO THE EXCLUSIVE RIGHT TO USE "WATER BOTTLING COMPANY", APART FROM THE MARK AS SHOWN.

SEC. 2(F).
FOR NUTRITIONALLY FORTIFIED WATER; VITAMIN ENRICHED WATER (U.S. CLS. 6, 18, 44, 46, 51 AND 52).

AMEEN IMAM, EXAMINING ATTORNEY

SN 85-256,805. BIOPHARMA PRODUCTS LLC, WORTHINGTON, MN. FILED 3-3-2011.

OSTEOBIOSCAFF

THE MARK CONSISTS OF STANDARD CHARACTERS WITHOUT CLAIM TO ANY PARTICULAR FONT, STYLE, SIZE, OR COLOR.

FOR VETERINARY PREPARATIONS, NAMELY, HYDROGELS FOR TISSUE AND BONE REGENERATION (U.S. CLS. 6, 18, 44, 46, 51 AND 52).

APRIL HESIK, EXAMINING ATTORNEY

SN 85-259,841. SEXUAL HEALTH RESEARCH CENTER, LLC, YONKERS, NY. FILED 3-7-2011.

STAMINA FOR MEN

THE MARK CONSISTS OF STANDARD CHARACTERS WITHOUT CLAIM TO ANY PARTICULAR FONT, STYLE, SIZE, OR COLOR.

NO CLAIM IS MADE TO THE EXCLUSIVE RIGHT TO USE "FOR MEN", APART FROM THE MARK AS SHOWN.

FOR DIETARY AND NUTRITIONAL SUPPLEMENTS TO IMPROVE SEXUAL PERFORMANCE (U.S. CLS. 6, 18, 44, 46, 51 AND 52).

FIRST USE 2-1-2011; IN COMMERCE 3-5-2011.
KIMBERLY PERRY, EXAMINING ATTORNEY

CLASS 5—(Continued).

SN 85-260,002. SEXUAL HEALTH RESEARCH CENTER, LLC, YONKERS, NY. FILED 3-7-2011.



NO CLAIM IS MADE TO THE EXCLUSIVE RIGHT TO USE "FOR MEN", APART FROM THE MARK AS SHOWN.

THE MARK CONSISTS OF THE WORD "STAMINA" IN LARGE TYPEFACE ABOVE THE TWO WORDS "FOR MEN", WITH AN UPWARD POINTING, SLIGHTLY CURVED ARROW REPLACING THE LETTER "I" IN "STAMINA".

FOR DIETARY AND NUTRITIONAL SUPPLEMENTS TO IMPROVE SEXUAL PERFORMANCE (U.S. CLS. 6, 18, 44, 46, 51 AND 52).

FIRST USE 2-1-2011; IN COMMERCE 3-5-2011.
KIMBERLY PERRY, EXAMINING ATTORNEY

SN 85-287,082. CATHERINE HUANG-BEGOVIC, FORMERLY CATHERINE HUANG, WEST HOLLYWOOD, CA. AND BINAIS BEGOVIC, WEST HOLLYWOOD, CA. FILED 4-5-2011.

MDSkin

THE MARK CONSISTS OF STANDARD CHARACTERS WITHOUT CLAIM TO ANY PARTICULAR FONT, STYLE, SIZE, OR COLOR.

FOR DIETARY AND NUTRITIONAL SUPPLEMENTS; DIETARY FOOD SUPPLEMENTS; DIETARY SUPPLEMENTAL DRINKS IN THE NATURE OF VITAMIN AND MINERAL BEVERAGES; DIETARY SUPPLEMENTS; DIETARY SUPPLEMENTS FOR HUMAN CONSUMPTION; FOOD SUPPLEMENTS; FOOD SUPPLEMENTS, NAMELY, ANTI-OXIDANTS; HEALTH FOOD SUPPLEMENTS; HERBAL SUPPLEMENTS; HOMEOPATHIC SUPPLEMENTS; LIQUID VITAMIN SUPPLEMENTS; MINERAL FOOD SUPPLEMENTS; MINERAL NUTRITIONAL SUPPLEMENTS; MIXED VITAMIN PREPARATIONS; MULTI-VITAMIN PREPARATIONS; NUTRITIONAL SUPPLEMENTS; POWDERED NUTRITIONAL SUPPLEMENT CONCENTRATE; VITAMIN AND MINERAL SUPPLEMENTS; VITAMIN B PREPARATIONS; VITAMIN C PREPARATIONS; VITAMIN ENRICHED BREAD FOR THERAPEUTIC PURPOSES; VITAMIN ENRICHED WATER; VITAMIN FORTIFIED BEVERAGES; VITAMIN PREPARATIONS; VITAMIN SUPPLEMENTS; VITAMIN TABLETS; VITAMINS (U.S. CLS. 6, 18, 44, 46, 51 AND 52).

JACQUELINE A. LAVINE, EXAMINING ATTORNEY

CLASS 5—(Continued).

SN 85-290,621. GREAT HEALTHWORKS, INC., HOLLYWOOD, FL. FILED 4-8-2011.

OMEGADOG

THE MARK CONSISTS OF STANDARD CHARACTERS WITHOUT CLAIM TO ANY PARTICULAR FONT, STYLE, SIZE, OR COLOR.

OWNER OF U.S. REG. NOS. 3,013,041, 3,900,712 AND OTHERS.

FOR NUTRITIONAL AND DIETARY SUPPLEMENTS FOR ANIMALS CONTAINING OMEGA FATTY ACID (U.S. CLS. 6, 18, 44, 46, 51 AND 52).

JENNY PARK, EXAMINING ATTORNEY

CLASS 5—(Continued).

SN 85-291,784. LIFECCELL CORPORATION, BRANCHBURG, NJ. FILED 4-11-2011.



THE MARK CONSISTS OF A RING SHADED ON EITHER SIDE CONNECTED AT THE TOP AND BOTTOM BY A SET OF DOTS.

FOR HUMAN TISSUE FOR TRANSPLANTATION PURPOSES; PROCESSED HUMAN DONOR SKIN FOR SKIN REPLACEMENT AND FOR TISSUE REGENERATION AND RECONSTRUCTION; IMPLANTS CONSISTING OF NATURAL BUT NON-LIVING BIOLOGICAL MATERIALS, NAMELY, AN ACELLULAR PORCINE MESH FOR USE IN THE SURGICAL REPAIR AND REINFORCEMENT OF SOFT TISSUE (U.S. CLS. 6, 18, 44, 46, 51 AND 52).

FIRST USE 1-1-2008; IN COMMERCE 1-1-2008.

KATHRYN COWARD, EXAMINING ATTORNEY

SN 85-291,593. HOLDEN, SCOTT W., KANSAS CITY, MO. FILED 4-11-2011.

Brownie Burger

THE MARK CONSISTS OF STANDARD CHARACTERS WITHOUT CLAIM TO ANY PARTICULAR FONT, STYLE, SIZE, OR COLOR.

NO CLAIM IS MADE TO THE EXCLUSIVE RIGHT TO USE "BROWNIE", APART FROM THE MARK AS SHOWN.

FOR DIETARY AND NUTRITIONAL SUPPLEMENTS; DIETARY AND NUTRITIONAL SUPPLEMENTS USED FOR WEIGHT LOSS; NUTRITIONAL FOOD BARS FOR USE AS A MEAL REPLACEMENT (U.S. CLS. 6, 18, 44, 46, 51 AND 52).

FIRST USE 4-11-2011; IN COMMERCE 4-11-2011.

ESTHER A. BORSUK, EXAMINING ATTORNEY

SN 85-295,528. ACTIVEPHYTO TECHNOLOGIES LIMITED, ST. HELIER, JERSEY, FILED 4-14-2011.

PC SPES

THE MARK CONSISTS OF STANDARD CHARACTERS WITHOUT CLAIM TO ANY PARTICULAR FONT, STYLE, SIZE, OR COLOR.

OWNER OF ERPN CMNTY TM OFC REG. NO. 006845812, DATED 5-14-2009, EXPIRES 4-18-2018.

FOR VITAMIN AND MINERAL SUPPLEMENTS IN THE NATURE OF HERBAL COMPOUNDS AND EXTRACTS USEFUL AS A DIETARY SUPPLEMENT TO SUPPORT IMMUNE SYSTEM FUNCTION, PROSTATE HEALTH, AND WELL-BEING; VITAMIN AND MINERAL SUPPLEMENTS; FOOD SUPPLEMENTS (U.S. CLS. 6, 18, 44, 46, 51 AND 52).

JOHN HWANG, EXAMINING ATTORNEY

CLASS 5—(Continued).

SN 85-297,732. INTELLIGENDER, LLC, PLANO, TX. FILED 4-18-2011.



THE COLOR(S) PINK AND BLUE IS/ARE CLAIMED AS A FEATURE OF THE MARK.

THE MARK CONSISTS OF THE FANCIFUL TERM "INTELLIGENDER" WITH PINK LETTERS "INTELLI", BLUE LETTERS "GENDER" AND THREE PAIRS OF PINK AND BLUE FEET. THE TERM "INTELLIGENDER" IS REPEATED TWICE IN A CIRCLE FORMAT AROUND ONE PAIR OF CENTRALLY LOCATED PINK AND BLUE FEET. EACH ADDITIONAL PAIR OF FEET IS PLACED BETWEEN THE TWO TERMS OF THE LITERAL ELEMENT.

FOR IN VITRO GENDER DETERMINATION SCREENING TEST (U.S. CLS. 6, 18, 44, 46, 51 AND 52).

FIRST USE 11-23-2006; IN COMMERCE 11-23-2006.

ALLISON HOLTZ, EXAMINING ATTORNEY

SN 85-301,297. ALAN BARRATT, SOLIHULL, B92 4NR, UNITED KINGDOM, FILED 4-21-2011.

DECLARE WAR ON FAT

THE MARK CONSISTS OF STANDARD CHARACTERS WITHOUT CLAIM TO ANY PARTICULAR FONT, STYLE, SIZE, OR COLOR.

FOR NUTRITIONAL SUPPLEMENT DRINKS AND SHAKES IN POWDER, LIQUID, AND MIX FORM FOR SPORTS ENHANCEMENT, PERFORMANCE ENHANCEMENT, WEIGHT MANAGEMENT, AND FOR USE AS A MEAL SUBSTITUTE; DIETARY DRINK MIX FOR USE AS A MEAL REPLACEMENT; VITAMINS, MINERAL SUPPLEMENTS, AND FOOD SUPPLEMENTS, NAMELY ANTI- OXIDANTS; MEAL REPLACEMENT BARS; FOOD AND DIETARY SUPPLEMENT FOR SPORTS ENHANCEMENT AND PERFORMANCE ENHANCEMENT; MEAL REPLACEMENT, WEIGHT GAIN, AND DIETARY SUPPLEMENT DRINK MIXES; WEIGHT LOSS, THERMOGENIC, AND VITAMIN FORMULAS IN TABLET AND CAPSULE FORM; APPETITE SUPPRESSANTS; DIET CAPSULES; DIET PILLS (U.S. CLS. 6, 18, 44, 46, 51 AND 52).

FRANK LATTUCA, EXAMINING ATTORNEY

CLASS 5—(Continued).

SN 85-302,077. THUNDERBIRD ENERGETICA LLC, AUSTIN, TX. FILED 4-22-2011.

THUNDERBIRD ENERGETICA

THE MARK CONSISTS OF STANDARD CHARACTERS WITHOUT CLAIM TO ANY PARTICULAR FONT, STYLE, SIZE, OR COLOR.

NO CLAIM IS MADE TO THE EXCLUSIVE RIGHT TO USE "ENERGETICA", APART FROM THE MARK AS SHOWN.

THE ENGLISH TRANSLATION OF THE WORD "ENERGETICA" IN THE MARK IS ENERGY.

FOR ENERGY BOOSTING BARS FOR USE AS MEAL SUBSTITUTE; NUTRITIONAL SUPPLEMENT ENERGY BARS (U.S. CLS. 6, 18, 44, 46, 51 AND 52).

FIRST USE 7-0-2010; IN COMMERCE 12-0-2010.

DANNEAN HETZEL, EXAMINING ATTORNEY

SN 85-302,576. BB ENDEAVORS LLC, NEW YORK, NY. FILED 4-22-2011.



THE MARK CONSISTS OF A GIRL WITH HER HAIR IN A PONYTAIL WEARING A HEADBAND, TANK TOP AND SHORTS, HOLDING AN APPLE IN HER LEFT HAND, WITH HER RIGHT HAND ON HER HIP.

FOR DIETARY AND NUTRITIONAL SUPPLEMENTS; NUTRITIONAL BARS FOR USE AS A MEAL REPLACEMENT; NUTRITIONAL SHAKES FOR USE AS A MEAL REPLACEMENT; MEAL REPLACEMENT SNACKS (U.S. CLS. 6, 18, 44, 46, 51 AND 52).

ANDREA BUTLER, EXAMINING ATTORNEY

CLASS 5—(Continued).

SN 85-302,671. ALIVAMAX WORLDWIDE, LLC, SALT LAKE CITY, UT. FILED 4-22-2011.

ALIVAMAX

THE MARK CONSISTS OF STANDARD CHARACTERS WITHOUT CLAIM TO ANY PARTICULAR FONT, STYLE, SIZE, OR COLOR.

FOR DIETARY SUPPLEMENTS AND NUTRITIONAL SUPPLEMENTS (U.S. CLS. 6, 18, 44, 46, 51 AND 52).

FIRST USE 1-0-2009; IN COMMERCE 1-0-2009.

KIMBERLY PERRY, EXAMINING ATTORNEY

SN 85-308,123. VIVIAN L KAMRATH, DBA NATURALRX, LLC, HAGER CITY, WI. FILED 4-29-2011.

Lice Ice

THE MARK CONSISTS OF STANDARD CHARACTERS WITHOUT CLAIM TO ANY PARTICULAR FONT, STYLE, SIZE, OR COLOR.

NO CLAIM IS MADE TO THE EXCLUSIVE RIGHT TO USE "LICE", APART FROM THE MARK AS SHOWN.

FOR LICE TREATMENT PREPARATIONS (U.S. CLS. 6, 18, 44, 46, 51 AND 52).

FIRST USE 3-1-2004; IN COMMERCE 3-1-2004.

SALLY SHIH, EXAMINING ATTORNEY

SN 85-313,712. ALIVAMAX WORLDWIDE, LLC, SALT LAKE CITY, UT. FILED 5-5-2011.

ALIVAMAX HYDRACELL

THE MARK CONSISTS OF STANDARD CHARACTERS WITHOUT CLAIM TO ANY PARTICULAR FONT, STYLE, SIZE, OR COLOR.

FOR DIETARY SUPPLEMENTS AND NUTRITIONAL SUPPLEMENTS (U.S. CLS. 6, 18, 44, 46, 51 AND 52).

FIRST USE 5-2-2011; IN COMMERCE 5-2-2011.

KIMBERLY PERRY, EXAMINING ATTORNEY

CLASS 5—(Continued).

SN 85-314,915. ALIVAMAX WORLDWIDE, LLC, SALT LAKE CITY, UT. FILED 5-6-2011.

ALIVAMAX 100% GOODNESS

THE MARK CONSISTS OF STANDARD CHARACTERS WITHOUT CLAIM TO ANY PARTICULAR FONT, STYLE, SIZE, OR COLOR.

FOR DIETARY SUPPLEMENTS AND NUTRITIONAL SUPPLEMENTS (U.S. CLS. 6, 18, 44, 46, 51 AND 52).

FIRST USE 4-12-2011; IN COMMERCE 4-12-2011.

KIMBERLY PERRY, EXAMINING ATTORNEY

SN 85-315,635. BRISTOL-MYERS SQUIBB COMPANY, NEW YORK, NY. FILED 5-9-2011.

EDEMPLIC

THE MARK CONSISTS OF STANDARD CHARACTERS WITHOUT CLAIM TO ANY PARTICULAR FONT, STYLE, SIZE, OR COLOR.

FOR PHARMACEUTICAL PREPARATIONS FOR HUMAN USE FOR THE TREATMENT AND PREVENTION OF OBESITY, DIABETES, INCONTINENCE, CARDIOVASCULAR DISEASES, CENTRAL NERVOUS SYSTEM DISEASES AND DISORDERS, METABOLIC DISORDERS, STROKE, CANCER, INFLAMMATION AND INFLAMMATORY DISEASES, RESPIRATORY AND INFECTIOUS DISEASES, AUTO-IMMUNE DISEASES, SOLID ORGAN TRANSPLANT REJECTION; PHARMACEUTICAL PREPARATIONS FOR HUMAN USE, NAMELY, ANTIBIOTICS, ANTI-FUNGALS, ANTI-VIRALS, IMMUNOSUPPRESSANTS AND PHARMACEUTICAL ANTIBODIES (U.S. CLS. 6, 18, 44, 46, 51 AND 52).

VIVIAN MICZNIK FIRST, EXAMINING ATTORNEY

CLASS 5—(Continued).

SN 85-315,644. BRISTOL-MYERS SQUIBB COMPANY, NEW YORK, NY. FILED 5-9-2011.

EMLIMET

THE MARK CONSISTS OF STANDARD CHARACTERS WITHOUT CLAIM TO ANY PARTICULAR FONT, STYLE, SIZE, OR COLOR.

FOR PHARMACEUTICAL PREPARATIONS FOR HUMAN USE FOR THE TREATMENT AND PREVENTION OF OBESITY, DIABETES, INCONTINENCE, CARDIOVASCULAR DISEASES, CENTRAL NERVOUS SYSTEM DISEASES AND DISORDERS, METABOLIC DISORDERS, STROKE, CANCER, INFLAMMATION AND INFLAMMATORY DISEASES, RESPIRATORY AND INFECTIOUS DISEASES, AUTO-IMMUNE DISEASES, SOLID ORGAN TRANSPLANT REJECTION; PHARMACEUTICAL PREPARATIONS FOR HUMAN USE, NAMELY, ANTIBIOTICS, ANTI-FUNGALS, ANTI-VIRALS, IMMUNOSUPPRESSANTS AND PHARMACEUTICAL ANTIBODIES (U.S. CLS. 6, 18, 44, 46, 51 AND 52).

VIVIAN MICZNIK FIRST, EXAMINING ATTORNEY

CLASS 5—(Continued).

SN 85-315,678. BRISTOL-MYERS SQUIBB COMPANY, NEW YORK, NY. FILED 5-9-2011.

TESYNPLI

THE MARK CONSISTS OF STANDARD CHARACTERS WITHOUT CLAIM TO ANY PARTICULAR FONT, STYLE, SIZE, OR COLOR.

FOR PHARMACEUTICAL PREPARATIONS FOR HUMAN USE FOR THE TREATMENT AND PREVENTION OF OBESITY, DIABETES, INCONTINENCE, CARDIOVASCULAR DISEASES, CENTRAL NERVOUS SYSTEM DISEASES AND DISORDERS, METABOLIC DISORDERS, STROKE, CANCER, INFLAMMATION AND INFLAMMATORY DISEASES, RESPIRATORY AND INFECTIOUS DISEASES, AUTO-IMMUNE DISEASES, SOLID ORGAN TRANSPLANT REJECTION; PHARMACEUTICAL PREPARATIONS FOR HUMAN USE, NAMELY, ANTIBIOTICS, ANTI-FUNGALS, ANTI-VIRALS, IMMUNOSUPPRESSANTS AND PHARMACEUTICAL ANTIBODIES (U.S. CLS. 6, 18, 44, 46, 51 AND 52).

VIVIAN MICZNIK FIRST, EXAMINING ATTORNEY

SN 85-317,104. TRUETONIQS, LLC, LONGMONT, CO. FILED 5-10-2011.

SN 85-315,650. BRISTOL-MYERS SQUIBB COMPANY, NEW YORK, NY. FILED 5-9-2011.

KOPLICIT

THE MARK CONSISTS OF STANDARD CHARACTERS WITHOUT CLAIM TO ANY PARTICULAR FONT, STYLE, SIZE, OR COLOR.

FOR PHARMACEUTICAL PREPARATIONS FOR HUMAN USE FOR THE TREATMENT AND PREVENTION OF OBESITY, DIABETES, INCONTINENCE, CARDIOVASCULAR DISEASES, CENTRAL NERVOUS SYSTEM DISEASES AND DISORDERS, METABOLIC DISORDERS, STROKE, CANCER, INFLAMMATION AND INFLAMMATORY DISEASES, RESPIRATORY AND INFECTIOUS DISEASES, AUTO-IMMUNE DISEASES, SOLID ORGAN TRANSPLANT REJECTION; PHARMACEUTICAL PREPARATIONS FOR HUMAN USE, NAMELY, ANTIBIOTICS, ANTI-FUNGALS, ANTI-VIRALS, IMMUNOSUPPRESSANTS AND PHARMACEUTICAL ANTIBODIES (U.S. CLS. 6, 18, 44, 46, 51 AND 52).

VIVIAN MICZNIK FIRST, EXAMINING ATTORNEY



OWNER OF U.S. REG. NOS. 3,637,800 AND 3,645,231.
NO CLAIM IS MADE TO THE EXCLUSIVE RIGHT TO USE "TONIC", APART FROM THE MARK AS SHOWN.

THE MARK CONSISTS OF THE WORD "TRIM" ABOVE THE WORD "TONIQ" IN STYLIZED FONT. A BUBBLE DESIGN ASCENDS UPWARD BEGINNING WITH THE DOT OF THE LETTER "I" IN THE WORD "TONIQ".

FOR DIETARY SUPPLEMENTS, NAMELY, HERBAL-ENHANCED BEVERAGES (U.S. CLS. 6, 18, 44, 46, 51 AND 52).

FIRST USE 3-15-2011; IN COMMERCE 3-15-2011.

KAREN SEVERSON, EXAMINING ATTORNEY

CLASS 5—(Continued).

SN 85-321,445. MIRZA, MOHAMMAD ALI, DUBAI, UNITED ARAB EMIR., FILED 5-16-2011.

FASTRIM

THE MARK CONSISTS OF STANDARD CHARACTERS WITHOUT CLAIM TO ANY PARTICULAR FONT, STYLE, SIZE, OR COLOR.

FOR DIETARY SUPPLEMENTS (U.S. CLS. 6, 18, 44, 46, 51 AND 52).

FIRST USE 6-7-2006; IN COMMERCE 6-7-2006.
BRIAN PINO, EXAMINING ATTORNEY

SN 85-323,796. DSHEALTHCARE INC., YORK, PA. FILED 5-18-2011.

VOLO

THE MARK CONSISTS OF STANDARD CHARACTERS WITHOUT CLAIM TO ANY PARTICULAR FONT, STYLE, SIZE, OR COLOR.

THE ENGLISH TRANSLATION OF "VOLO" IN THE MARK IS "FLIGHT".

FOR ALL PURPOSE DISINFECTANTS FOR USE BY MEDICAL AND DENTAL PROFESSIONALS FOR CLEANING AND DECONTAMINATING HARD NON-POROUS SURFACES AND FIXTURES IN HOSPITALS, SURGICAL CENTERS, NEONATAL UNITS, LABORATORIES, MEDICAL AND DENTAL OPERATORIES, AND FOR PRECLEANING AND DECONTAMINATING SURGICAL, MEDICAL, AND DENTAL INSTRUMENTS (U.S. CLS. 6, 18, 44, 46, 51 AND 52).

CHRISTINE COOPER, EXAMINING ATTORNEY

SN 85-332,618. ULTRA-AIRE INC., FOX RIVER GROVE, IL. FILED 5-27-2011.

ULTRA-AIRE

THE MARK CONSISTS OF STANDARD CHARACTERS WITHOUT CLAIM TO ANY PARTICULAR FONT, STYLE, SIZE, OR COLOR.

FOR AIR PURIFYING PREPARATIONS, NAMELY, A MISTING SOLUTION FOR ENCAPSULATING AIRBORNE ODIFEROUS COMPOUNDS AND ELIMINATING ODORS (U.S. CLS. 6, 18, 44, 46, 51 AND 52).

MARLENE BELL, EXAMINING ATTORNEY

CLASS 5—(Continued).

SN 85-333,524. BRISTOL-MYERS SQUIBB COMPANY, NEW YORK, NY. FILED 5-31-2011.

DUKIXITI

THE MARK CONSISTS OF STANDARD CHARACTERS WITHOUT CLAIM TO ANY PARTICULAR FONT, STYLE, SIZE, OR COLOR.

FOR PHARMACEUTICAL PREPARATIONS FOR HUMAN USE FOR THE TREATMENT AND PREVENTION OF OBESITY, DIABETES, INCONTINENCE, CARDIOVASCULAR DISEASES, CENTRAL NERVOUS SYSTEM DISEASES AND DISORDERS, METABOLIC DISORDERS, STROKE, CANCER, INFLAMMATION AND INFLAMMATORY DISEASES, RESPIRATORY AND INFECTIOUS DISEASES, AUTO-IMMUNE DISEASES, SOLID ORGAN TRANSPLANT REJECTION; PHARMACEUTICAL PREPARATIONS FOR HUMAN USE, NAMELY, ANTIBIOTICS, ANTI-FUNGALS, ANTI-VIRALS, IMMUNOSUPPRESSANTS AND PHARMACEUTICAL ANTIBODIES (U.S. CLS. 6, 18, 44, 46, 51 AND 52).

VIVIAN MICZNIK FIRST, EXAMINING ATTORNEY

SN 85-333,526. BRISTOL-MYERS SQUIBB COMPANY, NEW YORK, NY. FILED 5-31-2011.

DULIBITI

THE MARK CONSISTS OF STANDARD CHARACTERS WITHOUT CLAIM TO ANY PARTICULAR FONT, STYLE, SIZE, OR COLOR.

FOR PHARMACEUTICAL PREPARATIONS FOR HUMAN USE FOR THE TREATMENT AND PREVENTION OF OBESITY, DIABETES, INCONTINENCE, CARDIOVASCULAR DISEASES, CENTRAL NERVOUS SYSTEM DISEASES AND DISORDERS, METABOLIC DISORDERS, STROKE, CANCER, INFLAMMATION AND INFLAMMATORY DISEASES, RESPIRATORY AND INFECTIOUS DISEASES, AUTO-IMMUNE DISEASES, SOLID ORGAN TRANSPLANT REJECTION; PHARMACEUTICAL PREPARATIONS FOR HUMAN USE, NAMELY, ANTIBIOTICS, ANTI-FUNGALS, ANTI-VIRALS, IMMUNOSUPPRESSANTS AND PHARMACEUTICAL ANTIBODIES (U.S. CLS. 6, 18, 44, 46, 51 AND 52).

VIVIAN MICZNIK FIRST, EXAMINING ATTORNEY

CLASS 5—(Continued).

SN 85-333,527. BRISTOL-MYERS SQUIBB COMPANY, NEW YORK, NY. FILED 5-31-2011.

DUTIXITI

THE MARK CONSISTS OF STANDARD CHARACTERS WITHOUT CLAIM TO ANY PARTICULAR FONT, STYLE, SIZE, OR COLOR.

FOR PHARMACEUTICAL PREPARATIONS FOR HUMAN USE FOR THE TREATMENT AND PREVENTION OF OBESITY, DIABETES, INCONTINENCE, CARDIOVASCULAR DISEASES, CENTRAL NERVOUS SYSTEM DISEASES AND DISORDERS, METABOLIC DISORDERS, STROKE, CANCER, INFLAMMATION AND INFLAMMATORY DISEASES, RESPIRATORY AND INFECTIOUS DISEASES, AUTO-IMMUNE DISEASES, SOLID ORGAN TRANSPLANT REJECTION; PHARMACEUTICAL PREPARATIONS FOR HUMAN USE, NAMELY, ANTIBIOTICS, ANTI-FUNGALS, ANTI-VIRALS, IMMUNOSUPPRESSANTS AND PHARMACEUTICAL ANTIBODIES (U.S. CLS. 6, 18, 44, 46, 51 AND 52).
VIVIAN MICZNIK FIRST, EXAMINING ATTORNEY

CLASS 5—(Continued).

SN 85-333,530. BRISTOL-MYERS SQUIBB COMPANY, NEW YORK, NY. FILED 5-31-2011.

EMLINXETI

THE MARK CONSISTS OF STANDARD CHARACTERS WITHOUT CLAIM TO ANY PARTICULAR FONT, STYLE, SIZE, OR COLOR.

FOR PHARMACEUTICAL PREPARATIONS FOR HUMAN USE FOR THE TREATMENT AND PREVENTION OF OBESITY, DIABETES, INCONTINENCE, CARDIOVASCULAR DISEASES, CENTRAL NERVOUS SYSTEM DISEASES AND DISORDERS, METABOLIC DISORDERS, STROKE, CANCER, INFLAMMATION AND INFLAMMATORY DISEASES, RESPIRATORY AND INFECTIOUS DISEASES, AUTO-IMMUNE DISEASES, SOLID ORGAN TRANSPLANT REJECTION; PHARMACEUTICAL PREPARATIONS FOR HUMAN USE, NAMELY, ANTIBIOTICS, ANTI-FUNGALS, ANTI-VIRALS, IMMUNOSUPPRESSANTS AND PHARMACEUTICAL ANTIBODIES (U.S. CLS. 6, 18, 44, 46, 51 AND 52).
VIVIAN MICZNIK FIRST, EXAMINING ATTORNEY

SN 85-333,528. BRISTOL-MYERS SQUIBB COMPANY, NEW YORK, NY. FILED 5-31-2011.

EMDUXITI

THE MARK CONSISTS OF STANDARD CHARACTERS WITHOUT CLAIM TO ANY PARTICULAR FONT, STYLE, SIZE, OR COLOR.

FOR PHARMACEUTICAL PREPARATIONS FOR HUMAN USE FOR THE TREATMENT AND PREVENTION OF OBESITY, DIABETES, INCONTINENCE, CARDIOVASCULAR DISEASES, CENTRAL NERVOUS SYSTEM DISEASES AND DISORDERS, METABOLIC DISORDERS, STROKE, CANCER, INFLAMMATION AND INFLAMMATORY DISEASES, RESPIRATORY AND INFECTIOUS DISEASES, AUTO-IMMUNE DISEASES, SOLID ORGAN TRANSPLANT REJECTION; PHARMACEUTICAL PREPARATIONS FOR HUMAN USE, NAMELY, ANTIBIOTICS, ANTI-FUNGALS, ANTI-VIRALS, IMMUNOSUPPRESSANTS AND PHARMACEUTICAL ANTIBODIES (U.S. CLS. 6, 18, 44, 46, 51 AND 52).
VIVIAN MICZNIK FIRST, EXAMINING ATTORNEY

SN 85-333,533. BRISTOL-MYERS SQUIBB COMPANY, NEW YORK, NY. FILED 5-31-2011.

EMLINXITI

THE MARK CONSISTS OF STANDARD CHARACTERS WITHOUT CLAIM TO ANY PARTICULAR FONT, STYLE, SIZE, OR COLOR.

FOR PHARMACEUTICAL PREPARATIONS FOR HUMAN USE FOR THE TREATMENT AND PREVENTION OF OBESITY, DIABETES, INCONTINENCE, CARDIOVASCULAR DISEASES, CENTRAL NERVOUS SYSTEM DISEASES AND DISORDERS, METABOLIC DISORDERS, STROKE, CANCER, INFLAMMATION AND INFLAMMATORY DISEASES, RESPIRATORY AND INFECTIOUS DISEASES, AUTO-IMMUNE DISEASES, SOLID ORGAN TRANSPLANT REJECTION; PHARMACEUTICAL PREPARATIONS FOR HUMAN USE, NAMELY, ANTIBIOTICS, ANTI-FUNGALS, ANTI-VIRALS, IMMUNOSUPPRESSANTS AND PHARMACEUTICAL ANTIBODIES (U.S. CLS. 6, 18, 44, 46, 51 AND 52).
VIVIAN MICZNIK FIRST, EXAMINING ATTORNEY

CLASS 5—(Continued).

SN 85-333,545. BRISTOL-MYERS SQUIBB COMPANY, NEW YORK, NY. FILED 5-31-2011.

METLINXITI

THE MARK CONSISTS OF STANDARD CHARACTERS WITHOUT CLAIM TO ANY PARTICULAR FONT, STYLE, SIZE, OR COLOR.

FOR PHARMACEUTICAL PREPARATIONS FOR HUMAN USE FOR THE TREATMENT AND PREVENTION OF OBESITY, DIABETES, INCONTINENCE, CARDIOVASCULAR DISEASES, CENTRAL NERVOUS SYSTEM DISEASES AND DISORDERS, METABOLIC DISORDERS, STROKE, CANCER, INFLAMMATION AND INFLAMMATORY DISEASES, RESPIRATORY AND INFECTIOUS DISEASES, AUTO-IMMUNE DISEASES, SOLID ORGAN TRANSPLANT REJECTION; PHARMACEUTICAL PREPARATIONS FOR HUMAN USE, NAMELY, ANTIBIOTICS, ANTI-FUNGALS, ANTI-VIRALS, IMMUNOSUPPRESSANTS AND PHARMACEUTICAL ANTIBODIES (U.S. CLS. 6, 18, 44, 46, 51 AND 52).
VIVIAN MICZNIK FIRST, EXAMINING ATTORNEY

SN 85-333,549. BRISTOL-MYERS SQUIBB COMPANY, NEW YORK, NY. FILED 5-31-2011.

PLICIDU

THE MARK CONSISTS OF STANDARD CHARACTERS WITHOUT CLAIM TO ANY PARTICULAR FONT, STYLE, SIZE, OR COLOR.

FOR PHARMACEUTICAL PREPARATIONS FOR HUMAN USE FOR THE TREATMENT AND PREVENTION OF OBESITY, DIABETES, INCONTINENCE, CARDIOVASCULAR DISEASES, CENTRAL NERVOUS SYSTEM DISEASES AND DISORDERS, METABOLIC DISORDERS, STROKE, CANCER, INFLAMMATION AND INFLAMMATORY DISEASES, RESPIRATORY AND INFECTIOUS DISEASES, AUTO-IMMUNE DISEASES, SOLID ORGAN TRANSPLANT REJECTION; PHARMACEUTICAL PREPARATIONS FOR HUMAN USE, NAMELY, ANTIBIOTICS, ANTI-FUNGALS, ANTI-VIRALS, IMMUNOSUPPRESSANTS AND PHARMACEUTICAL ANTIBODIES (U.S. CLS. 6, 18, 44, 46, 51 AND 52).
VIVIAN MICZNIK FIRST, EXAMINING ATTORNEY

CLASS 5—(Continued).

SN 85-333,551. BRISTOL-MYERS SQUIBB COMPANY, NEW YORK, NY. FILED 5-31-2011.

PLICITU

THE MARK CONSISTS OF STANDARD CHARACTERS WITHOUT CLAIM TO ANY PARTICULAR FONT, STYLE, SIZE, OR COLOR.

FOR PHARMACEUTICAL PREPARATIONS FOR HUMAN USE FOR THE TREATMENT AND PREVENTION OF OBESITY, DIABETES, INCONTINENCE, CARDIOVASCULAR DISEASES, CENTRAL NERVOUS SYSTEM DISEASES AND DISORDERS, METABOLIC DISORDERS, STROKE, CANCER, INFLAMMATION AND INFLAMMATORY DISEASES, RESPIRATORY AND INFECTIOUS DISEASES, AUTO-IMMUNE DISEASES, SOLID ORGAN TRANSPLANT REJECTION; PHARMACEUTICAL PREPARATIONS FOR HUMAN USE, NAMELY, ANTIBIOTICS, ANTI-FUNGALS, ANTI-VIRALS, IMMUNOSUPPRESSANTS AND PHARMACEUTICAL ANTIBODIES (U.S. CLS. 6, 18, 44, 46, 51 AND 52).
VIVIAN MICZNIK FIRST, EXAMINING ATTORNEY

SN 85-334,729. TEVA ANIMAL HEALTH, INC., ST. JOSEPH, MO. FILED 6-1-2011.

SCOUR-HALT

THE MARK CONSISTS OF STANDARD CHARACTERS WITHOUT CLAIM TO ANY PARTICULAR FONT, STYLE, SIZE, OR COLOR.

FOR PHARMACEUTICAL PREPARATION, NAMELY, A VETERINARY ANTIBIOTIC FOR THE TREATMENT OF SWINE (U.S. CLS. 6, 18, 44, 46, 51 AND 52).
JEFFERY COWARD, EXAMINING ATTORNEY

SN 85-336,878. EXELIXIS, INC., SOUTH SAN FRANCISCO, CA. FILED 6-2-2011.

KOMETRIQ

THE MARK CONSISTS OF STANDARD CHARACTERS WITHOUT CLAIM TO ANY PARTICULAR FONT, STYLE, SIZE, OR COLOR.

FOR PHARMACEUTICAL PREPARATIONS FOR THE TREATMENT OF CANCER, PAIN, INFECTION, INFLAMMATION, HORMONE DISORDERS, BONE DISORDERS, AND MENTAL DISORDERS; ANALGESICS; HORMONES; PSYCHOTROPICS; ANTI-INFECTIVES; ANTI-INFLAMMATORIES; ANTI-CANCER PREPARATIONS (U.S. CLS. 6, 18, 44, 46, 51 AND 52).
ASMAT KHAN, EXAMINING ATTORNEY

CLASS 5—(Continued).

SN 85-336,889. EXELIXIS, INC., SOUTH SAN FRANCISCO, CA. FILED 6-2-2011.

KOMETRIX

THE MARK CONSISTS OF STANDARD CHARACTERS WITHOUT CLAIM TO ANY PARTICULAR FONT, STYLE, SIZE, OR COLOR.

FOR PHARMACEUTICAL PREPARATIONS FOR THE TREATMENT OF CANCER, PAIN, INFECTION, INFLAMMATION, HORMONE DISORDERS, BONE DISORDERS, AND MENTAL DISORDERS; ANALGESICS; HORMONES; PSYCHOTROPICS; ANTI-INFECTIVES; ANTI-INFLAMMATORIES; ANTI-CANCER PREPARATIONS (U.S. CLS. 6, 18, 44, 46, 51 AND 52).

ASMAT KHAN, EXAMINING ATTORNEY

CLASS 5—(Continued).

SN 85-347,902. PEACEFUL MOUNTAIN, INC., WOODBINE, IA. FILED 6-16-2011.

BACK AND NECK RESCUE

THE MARK CONSISTS OF STANDARD CHARACTERS WITHOUT CLAIM TO ANY PARTICULAR FONT, STYLE, SIZE, OR COLOR.

OWNER OF U.S. REG. NO. 3,044,544.

NO CLAIM IS MADE TO THE EXCLUSIVE RIGHT TO USE "BACK" AND "NECK", APART FROM THE MARK AS SHOWN.

FOR TOPICAL GEL FOR MEDICAL AND THERAPEUTIC TREATMENT OF BACK AND NECK PAIN (U.S. CLS. 6, 18, 44, 46, 51 AND 52).

FIRST USE 2-28-2004; IN COMMERCE 2-28-2004.

KEVIN CORWIN, EXAMINING ATTORNEY

SN 85-336,897. EXELIXIS, INC., SOUTH SAN FRANCISCO, CA. FILED 6-2-2011.

KOMETRIK

THE MARK CONSISTS OF STANDARD CHARACTERS WITHOUT CLAIM TO ANY PARTICULAR FONT, STYLE, SIZE, OR COLOR.

FOR PHARMACEUTICAL PREPARATIONS FOR THE TREATMENT OF CANCER, PAIN, INFECTION, INFLAMMATION, HORMONE DISORDERS, BONE DISORDERS, AND MENTAL DISORDERS; ANALGESICS; HORMONES; PSYCHOTROPICS; ANTI-INFECTIVES; ANTI-INFLAMMATORIES; ANTI-CANCER PREPARATIONS (U.S. CLS. 6, 18, 44, 46, 51 AND 52).

ASMAT KHAN, EXAMINING ATTORNEY

SN 85-358,674. AXIS LABS, INC., LONE TREE, CO. FILED 6-28-2011.

Endoshield

THE MARK CONSISTS OF STANDARD CHARACTERS WITHOUT CLAIM TO ANY PARTICULAR FONT, STYLE, SIZE, OR COLOR.

FOR DIETARY AND NUTRITIONAL SUPPLEMENTS SOLD OVER THE COUNTER ONLY, WITHOUT THE NEED FOR A PHYSICIAN'S PRESCRIPTION (U.S. CLS. 6, 18, 44, 46, 51 AND 52).

TRICIA SONNEBORN, EXAMINING ATTORNEY

SN 85-344,587. TRIS PHARMA, INC, MONMOUTH JUNCTION, NJ. FILED 6-13-2011.

KARBINAL

THE MARK CONSISTS OF STANDARD CHARACTERS WITHOUT CLAIM TO ANY PARTICULAR FONT, STYLE, SIZE, OR COLOR.

FOR ORAL EXTENDED RELEASE PHARMACEUTICAL PREPARATIONS FOR THE DRUG CARBINOXAMINE, INTENDED FOR THE TREATMENT OF SEASONAL AND PERENNIAL ALLERGIC RHINITIS (U.S. CLS. 6, 18, 44, 46, 51 AND 52).

JOSETTE BEVERLY, EXAMINING ATTORNEY

SN 85-368,946. MED COAT AB, STOCKHOLM, SWEDEN, FILED 7-12-2011.

MEDCOAT

THE MARK CONSISTS OF STANDARD CHARACTERS WITHOUT CLAIM TO ANY PARTICULAR FONT, STYLE, SIZE, OR COLOR.

OWNER OF U.S. REG. NO. 2,916,250.

FOR PHARMACOLOGICALLY INACTIVE SUBSTANCE FOR USE BY CONSUMERS TO COAT TABLETS, CAPSULES AND PILLS TO MAKE THEM MORE PALATABLE AND EASIER TO SWALLOW (U.S. CLS. 6, 18, 44, 46, 51 AND 52).

DEBORAH LOBO, EXAMINING ATTORNEY

CLASS 5—(Continued).

SN 85-390,061. OKTOS SURGICAL CORPORATION, COSTA MESA, CA. FILED 8-4-2011.

AMBIODRY2

THE MARK CONSISTS OF STANDARD CHARACTERS WITHOUT CLAIM TO ANY PARTICULAR FONT, STYLE, SIZE, OR COLOR.

FOR BIOLOGICAL TISSUE FOR USE IN SURGERY (U.S. CLS. 6, 18, 44, 46, 51 AND 52).
FIRST USE 12-1-2006; IN COMMERCE 12-1-2006.
SANJEEV VOHRA, EXAMINING ATTORNEY

SN 85-390,080. OKTOS SURGICAL CORPORATION, COSTA MESA, CA. FILED 8-4-2011.

AMBIODRY

THE MARK CONSISTS OF STANDARD CHARACTERS WITHOUT CLAIM TO ANY PARTICULAR FONT, STYLE, SIZE, OR COLOR.

FOR BIOLOGICAL TISSUE FOR USE IN SURGERY (U.S. CLS. 6, 18, 44, 46, 51 AND 52).
FIRST USE 11-2-2002; IN COMMERCE 11-2-2002.
SANJEEV VOHRA, EXAMINING ATTORNEY

SN 85-395,292. VITASPORT, INC., ONTARIO, CA. FILED 8-11-2011.

EVOCHEM

THE MARK CONSISTS OF STANDARD CHARACTERS WITHOUT CLAIM TO ANY PARTICULAR FONT, STYLE, SIZE, OR COLOR.

FOR DIETARY FOOD SUPPLEMENTS; DIETARY SUPPLEMENTS; NUTRITIONAL SUPPLEMENTS; VITAMINS; DIETARY SUPPLEMENTS AND NUTRITIONAL SUPPLEMENTS FOR ENDURANCE SPORTS, AND DIETARY SUPPLEMENTS USED FOR WEIGHT LOSS (U.S. CLS. 6, 18, 44, 46, 51 AND 52).

FIRST USE 9-1-2011; IN COMMERCE 9-1-2011.
ODESSA BIBBINS, EXAMINING ATTORNEY

CLASS 5—(Continued).

SN 85-396,369. VITASPORT, INC., ONTARIO, CA. FILED 8-12-2011.



NO CLAIM IS MADE TO THE EXCLUSIVE RIGHT TO USE "NUTRITION", APART FROM THE MARK AS SHOWN.

THE MARK CONSISTS OF A SHADED CIRCLE CONTAINING THE UNSHADED LETTERS, "EVO" IN ALL CAPS, WITH THE WORDING "CHEM" TO THE RIGHT IN LOWER CASE, WITH THE WORDING, "N U T R I T I O N" CONTAINING SPACE BETWEEN EACH OF THE LETTERS, IN LOWER CASE, BELOW "CHEM".

FOR DIETARY FOOD SUPPLEMENTS; DIETARY SUPPLEMENTS; NUTRITIONAL SUPPLEMENTS; VITAMINS; DIETARY SUPPLEMENTS AND NUTRITIONAL SUPPLEMENTS FOR ENDURANCE SPORTS, AND DIETARY SUPPLEMENTS USED FOR WEIGHT LOSS (U.S. CLS. 6, 18, 44, 46, 51 AND 52).

FIRST USE 9-1-2011; IN COMMERCE 9-1-2011.
ODESSA BIBBINS, EXAMINING ATTORNEY

SN 85-397,335. H&A NUTRITION, INC., ST CLAIR SHORES, MI. FILED 8-13-2011.

RUTEIN

THE MARK CONSISTS OF STANDARD CHARACTERS WITHOUT CLAIM TO ANY PARTICULAR FONT, STYLE, SIZE, OR COLOR.

FOR NUTRITIONAL DIET SUPPLEMENT FOR WEIGHT CONTROL (U.S. CLS. 6, 18, 44, 46, 51 AND 52).
JOHN KELLY, EXAMINING ATTORNEY

SN 85-400,829. SILAS, RUDOLPH, NEW YORK, NY. FILED 8-18-2011.

EMUNO BAR

THE MARK CONSISTS OF STANDARD CHARACTERS WITHOUT CLAIM TO ANY PARTICULAR FONT, STYLE, SIZE, OR COLOR.

NO CLAIM IS MADE TO THE EXCLUSIVE RIGHT TO USE "BAR", APART FROM THE MARK AS SHOWN.

THE WORDING "EMUNO" HAS NO MEANING IN A FOREIGN LANGUAGE.

FOR NUTRITIONAL AND DIETARY SUPPLEMENTS FORMED AND PACKAGED AS BARS (U.S. CLS. 6, 18, 44, 46, 51 AND 52).

FIRST USE 10-3-2003; IN COMMERCE 1-1-2005.
NELSON SNYDER, EXAMINING ATTORNEY

CLASS 5—(Continued).

SN 85-419,230. FOUGERA PHARMACEUTICALS INC., MELVILLE, NY. FILED 9-9-2011.

CLASS 5—(Continued).

SN 85-419,232. FOUGERA PHARMACEUTICALS INC., MELVILLE, NY. FILED 9-9-2011.

FOUGERA

FOUGERA PHARMACEUTICALS
INC.

THE MARK CONSISTS OF STANDARD CHARACTERS WITHOUT CLAIM TO ANY PARTICULAR FONT, STYLE, SIZE, OR COLOR.

OWNER OF U.S. REG. NOS. 199,022, 1,523,152 AND 2,904,741.

FOR PHARMACEUTICAL AND MEDICATED PREPARATIONS AND SUBSTANCES FOR THE PREVENTION, TREATMENT AND/OR ALLEVIATION OF DERMATOLOGICAL DISEASES, DISORDERS AND CONDITIONS; PHARMACEUTICAL AND MEDICATED PREPARATIONS, NAMELY, OINTMENTS, CREAMS, GELS, LOTIONS, SUSPENSIONS AND SOLUTIONS FOR THE PREVENTION, TREATMENT AND/OR ALLEVIATION OF DERMATOLOGICAL DISEASES, DISORDERS AND CONDITIONS; ORAL AND TOPICAL ANTIBIOTICS; TOPICAL ANESTHETICS; TOPICAL CORTICOSTEROID PREPARATIONS; MEDICATED PADS FOR THE TREATMENT OF SKIN WARTS; MEDICATED PREPARATIONS FOR VAGINAL USE NAMELY, ANTIFUNGALS AND ANTI-INFECTIVE PREPARATIONS; STERILE SURGICAL LUBRICANT; MEDICINAL PREPARATION FOR USE AS AN ANTISPASMODIC AND ANTI-SECRETORY AGENT; STERILE SOLUTIONS FOR NASAL LAVAGE USE; MEDICATED SOLUTIONS FOR NASAL DECONGESTANT USE; DIETARY SUPPLEMENTS; PHARMACEUTICAL PREPARATIONS FOR USE AS AN EAR WATER DRYING AID (U.S. CLS. 6, 18, 44, 46, 51 AND 52).

JIM RINGLE, EXAMINING ATTORNEY

THE MARK CONSISTS OF STANDARD CHARACTERS WITHOUT CLAIM TO ANY PARTICULAR FONT, STYLE, SIZE, OR COLOR.

OWNER OF U.S. REG. NOS. 199,022, 1,523,152 AND 2,904,741.

NO CLAIM IS MADE TO THE EXCLUSIVE RIGHT TO USE "PHARMACEUTICALS INC.", APART FROM THE MARK AS SHOWN.

FOR PHARMACEUTICAL AND MEDICATED PREPARATIONS AND SUBSTANCES FOR THE PREVENTION, TREATMENT AND/OR ALLEVIATION OF DERMATOLOGICAL DISEASES, DISORDERS AND CONDITIONS; PHARMACEUTICAL AND MEDICATED PREPARATIONS, NAMELY, OINTMENTS, CREAMS, GELS, LOTIONS, SUSPENSIONS AND SOLUTIONS FOR THE PREVENTION, TREATMENT AND/OR ALLEVIATION OF DERMATOLOGICAL DISEASES, DISORDERS AND CONDITIONS; ORAL AND TOPICAL ANTIBIOTICS; TOPICAL ANESTHETICS; TOPICAL CORTICOSTEROID PREPARATIONS; MEDICATED PADS FOR THE TREATMENT OF SKIN WARTS; MEDICATED PREPARATIONS FOR VAGINAL USE, NAMELY, ANTIFUNGALS AND ANTI-INFECTIVE PREPARATIONS; STERILE SURGICAL LUBRICANT; MEDICINAL PREPARATION FOR USE AS AN ANTISPASMODIC AND ANTI-SECRETORY AGENT; STERILE SOLUTIONS FOR NASAL LAVAGE USE; MEDICATED SOLUTIONS FOR NASAL DECONGESTANT USE; DIETARY SUPPLEMENTS; PHARMACEUTICAL PREPARATIONS FOR USE AS AN EAR WATER DRYING AID (U.S. CLS. 6, 18, 44, 46, 51 AND 52).

JIM RINGLE, EXAMINING ATTORNEY

SN 85-424,207. UNIVERA, INC., LACEY, WA. FILED 9-15-2011.

INTHINITY

THE MARK CONSISTS OF STANDARD CHARACTERS WITHOUT CLAIM TO ANY PARTICULAR FONT, STYLE, SIZE, OR COLOR.

OWNER OF U.S. REG. NO. 2,751,414.

FOR DIETARY SUPPLEMENTS, NAMELY, DIETARY DRINK MIX FOR USE AS A MEAL REPLACEMENT (U.S. CLS. 6, 18, 44, 46, 51 AND 52).

FIRST USE 4-30-2002; IN COMMERCE 4-30-2002.

BRIDGETT SMITH, EXAMINING ATTORNEY

CLASS 5—(Continued).

SN 85-424,534. FOUGERA PHARMACEUTICALS INC., MELVILLE, NY. FILED 9-16-2011.



OWNER OF U.S. REG. NOS. 199,022, 1,523,152 AND 2,904,741.

NO CLAIM IS MADE TO THE EXCLUSIVE RIGHT TO USE "PHARMACEUTICALS INC.", APART FROM THE MARK AS SHOWN.

THE MARK CONSISTS OF THE WORD "FOUGERA" CENTERED ABOVE THE WORDS "PHARMACEUTICALS INC". THE TOP BAR OF THE LETTER "F" EXTENDS ACROSS THE WORD "FOUGERA" TO THE LETTER "A". CENTERED ABOVE THE WORDING IS A THREE-DIMENSIONAL BOX WITH A CHECK MARK.

FOR PHARMACEUTICAL AND MEDICATED PREPARATIONS AND SUBSTANCES FOR THE PREVENTION, TREATMENT AND/OR ALLEVIATION OF DERMATOLOGICAL DISEASES, DISORDERS AND CONDITIONS; PHARMACEUTICAL AND MEDICATED PREPARATIONS, NAMELY, OINTMENTS, CREAMS, GELS, LOTIONS, SUSPENSIONS AND SOLUTIONS FOR THE PREVENTION, TREATMENT AND/OR ALLEVIATION OF DERMATOLOGICAL DISEASES, DISORDERS AND CONDITIONS; ORAL AND TOPICAL ANTIBIOTICS; TOPICAL ANESTHETICS; TOPICAL CORTICOSTEROID PREPARATIONS; MEDICATED PADS FOR THE TREATMENT OF SKIN WARTS; MEDICATED PREPARATIONS FOR VAGINAL USE, NAMELY, ANTIFUNGALS AND ANTI-INFECTIVE PREPARATIONS; STERILE SURGICAL LUBRICANT; MEDICINAL PREPARATION FOR USE AS AN ANTISPASMODIC AND ANTI-SECRETORY AGENT; STERILE SOLUTIONS FOR NASAL LAVAGE USE; MEDICATED SOLUTIONS FOR NASAL DECONGESTANT USE; DIETARY SUPPLEMENTS; PHARMACEUTICAL PREPARATIONS FOR USE AS AN EAR WATER DRYING AID (U.S. CLS. 6, 18, 44, 46, 51 AND 52).

JIM RINGLE, EXAMINING ATTORNEY

CLASS 5—(Continued).

SN 85-424,536. FOUGERA PHARMACEUTICALS INC., MELVILLE, NY. FILED 9-16-2011.



THE MARK CONSISTS OF A CHECK MARK WHICH APPEARS SUPERIMPOSED ON A THREE-DIMENSIONAL BOX DESIGN.

FOR PHARMACEUTICAL AND MEDICATED PREPARATIONS AND SUBSTANCES FOR THE PREVENTION, TREATMENT AND/OR ALLEVIATION OF DERMATOLOGICAL DISEASES, DISORDERS AND CONDITIONS; PHARMACEUTICAL AND MEDICATED PREPARATIONS, NAMELY, OINTMENTS, CREAMS, GELS, LOTIONS, SUSPENSIONS AND SOLUTIONS FOR THE PREVENTION, TREATMENT AND/OR ALLEVIATION OF DERMATOLOGICAL DISEASES, DISORDERS AND CONDITIONS; ORAL AND TOPICAL ANTIBIOTICS; TOPICAL ANESTHETICS; TOPICAL CORTICOSTEROID PREPARATIONS; MEDICATED PADS FOR THE TREATMENT OF SKIN WARTS; MEDICATED PREPARATIONS FOR VAGINAL USE, NAMELY, ANTIFUNGALS AND ANTI-INFECTIVE PREPARATIONS; STERILE SURGICAL LUBRICANT; MEDICINAL PREPARATION FOR USE AS AN ANTISPASMODIC AND ANTI-SECRETORY AGENT; STERILE SOLUTIONS FOR NASAL LAVAGE USE; MEDICATED SOLUTIONS FOR NASAL DECONGESTANT USE; DIETARY SUPPLEMENTS; PHARMACEUTICAL PREPARATIONS FOR USE AS AN EAR WATER DRYING AID (U.S. CLS. 6, 18, 44, 46, 51 AND 52).

JIM RINGLE, EXAMINING ATTORNEY

SN 85-426,436. MONAVIE LLC, SOUTH JORDAN, UT. FILED 9-19-2011.

NUTRITIONAL CHEMISTRY

THE MARK CONSISTS OF STANDARD CHARACTERS WITHOUT CLAIM TO ANY PARTICULAR FONT, STYLE, SIZE, OR COLOR.

NO CLAIM IS MADE TO THE EXCLUSIVE RIGHT TO USE "NUTRITIONAL", APART FROM THE MARK AS SHOWN.

FOR POWDERED FRUIT-FLAVORED DIETARY SUPPLEMENT DRINK MIX; POWDERED NUTRITIONAL SUPPLEMENT DRINK MIX; POWDERED NUTRITIONAL SUPPLEMENT DRINK MIX AND CONCENTRATE (U.S. CLS. 6, 18, 44, 46, 51 AND 52).

DAWN HAN, EXAMINING ATTORNEY

CLASS 5—(Continued).

SN 85-427,843. DDS PREMIER, INC., GAINESVILLE, GA. FILED 9-21-2011.

**OMG!!! BY POWERSPORT
INTERNATIONAL**

THE MARK CONSISTS OF STANDARD CHARACTERS WITHOUT CLAIM TO ANY PARTICULAR FONT, STYLE, SIZE, OR COLOR.

NO CLAIM IS MADE TO THE EXCLUSIVE RIGHT TO USE "INTERNATIONAL", APART FROM THE MARK AS SHOWN.

FOR DIETARY AND NUTRITIONAL SUPPLEMENTS; DIETARY SUPPLEMENTS (U.S. CLS. 6, 18, 44, 46, 51 AND 52).

TRICIA SONNEBORN, EXAMINING ATTORNEY

SN 85-430,840. MAID BRANDS, INC., ST. LOUIS, MO. FILED 9-23-2011.

HAWAIIAN FRESH

THE MARK CONSISTS OF STANDARD CHARACTERS WITHOUT CLAIM TO ANY PARTICULAR FONT, STYLE, SIZE, OR COLOR.

FOR AIR FRESHENERS, DEODORIZERS FOR FABRICS, AND CARPET DEODORIZERS (U.S. CLS. 6, 18, 44, 46, 51 AND 52).

ANDREA BUTLER, EXAMINING ATTORNEY

SN 85-431,445. AMERICAN GREEN PRODUCTS, LLC, IRVINE, CA. FILED 9-26-2011.

Quench The Nicotine Urge!

THE MARK CONSISTS OF STANDARD CHARACTERS WITHOUT CLAIM TO ANY PARTICULAR FONT, STYLE, SIZE, OR COLOR.

FOR NICOTINE REPLACEMENT PRODUCTS AS AN ALTERNATIVE TO SMOKING TOBACCO, NAMELY, ELECTRONIC CIGARETTES, NICOTINE WATER, NICOTINE DRINKS, NICOTINE GUM, ORAL SPRAYS FOR THE CESSATION OF SMOKING, SMOKING CESSATION PREPARATIONS, IMITATION CIGARETTES FOR QUITTING SMOKING, AND TRANSDERMAL PATCHES CONTAINING NICOTINE (U.S. CLS. 6, 18, 44, 46, 51 AND 52).

FIRST USE 9-2-2011; IN COMMERCE 9-2-2011.
REBECCA POVARCHUK, EXAMINING ATTORNEY

CLASS 5—(Continued).

SN 85-435,809. KING RICHARD PROMOTIONS, INC., DBA DBI DISTRIBUTION CORPORATION, CARMEL, IN. FILED 9-29-2011.

MINI THIN 25/50

THE MARK CONSISTS OF STANDARD CHARACTERS WITHOUT CLAIM TO ANY PARTICULAR FONT, STYLE, SIZE, OR COLOR.

OWNER OF U.S. REG. NOS. 2,488,870, 2,738,788 AND OTHERS.

FOR DIETARY SUPPLEMENTS (U.S. CLS. 6, 18, 44, 46, 51 AND 52).

FIRST USE 2-1-2010; IN COMMERCE 2-10-2010.
ANDREW LEASER, EXAMINING ATTORNEY

SN 85-438,775. BONY AÇAI IMP. EXP. E COMERCIO DE BEBIDAS LTDA., MARITUBA, PARA, BRAZIL, FILED 10-4-2011.



OWNER OF U.S. REG. NOS. 3,726,461 AND 3,799,441.
NO CLAIM IS MADE TO THE EXCLUSIVE RIGHT TO USE "AÇAI", APART FROM THE MARK AS SHOWN.

THE MARK CONSISTS OF A SHADED CIRCLE SURROUNDED BY AN OUTLINE OF A CIRCLE, A SECOND LARGER OUTLINE OF A CIRCLE SURROUNDING THE FIRST CIRCLE, AND THE WORDS "BONY AÇAI" BELOW IN A STYLIZED FONT.

FOR MULTIVITAMINS CONTAINING AÇAI (U.S. CLS. 6, 18, 44, 46, 51 AND 52).
JOHN WILKE, EXAMINING ATTORNEY

SN 85-442,971. DRIVEN SPORTS, INC., FRANKLIN SQUARE, NY. FILED S.R. 10-9-2011; AM. P.R. 2-3-2012.

LevoTest

THE MARK CONSISTS OF STANDARD CHARACTERS WITHOUT CLAIM TO ANY PARTICULAR FONT, STYLE, SIZE, OR COLOR.

FOR DIETARY AND NUTRITIONAL SUPPLEMENTS (U.S. CLS. 6, 18, 44, 46, 51 AND 52).

FIRST USE 9-1-2010; IN COMMERCE 9-1-2010.
H. M. FISHER, EXAMINING ATTORNEY

CLASS 5—(Continued).

SN 85-442,976. DRIVEN SPORTS, INC., FRANKLIN SQUARE, NY. FILED S.R. 10-9-2011; AM. P.R. 2-3-2012.

pZole

THE MARK CONSISTS OF STANDARD CHARACTERS WITHOUT CLAIM TO ANY PARTICULAR FONT, STYLE, SIZE, OR COLOR.
FOR DIETARY AND NUTRITIONAL SUPPLEMENTS (U.S. CLS. 6, 18, 44, 46, 51 AND 52).
FIRST USE 8-21-2010; IN COMMERCE 8-21-2010.
H. M. FISHER, EXAMINING ATTORNEY

SN 85-442,978. DRIVEN SPORTS, INC., FRANKLIN SQUARE, NY. FILED S.R. 10-9-2011; AM. P.R. 2-6-2012.

LetroDex

THE MARK CONSISTS OF STANDARD CHARACTERS WITHOUT CLAIM TO ANY PARTICULAR FONT, STYLE, SIZE, OR COLOR.
FOR DIETARY AND NUTRITIONAL SUPPLEMENTS (U.S. CLS. 6, 18, 44, 46, 51 AND 52).
FIRST USE 8-21-2010; IN COMMERCE 8-21-2010.
H. M. FISHER, EXAMINING ATTORNEY

SN 85-443,227. EVANS, SUSAN E., LOS ANGELES, CA. FILED 10-10-2011.

Kava Cat

THE MARK CONSISTS OF STANDARD CHARACTERS WITHOUT CLAIM TO ANY PARTICULAR FONT, STYLE, SIZE, OR COLOR.
NO CLAIM IS MADE TO THE EXCLUSIVE RIGHT TO USE "KAVA", APART FROM THE MARK AS SHOWN.
FOR DIETARY AND NUTRITIONAL SUPPLEMENTS CONTAINING KAVA FOR HUMAN USE (U.S. CLS. 6, 18, 44, 46, 51 AND 52).
EMILY CARLSEN, EXAMINING ATTORNEY

CLASS 5—(Continued).

SN 85-444,314. DONG RIN KIM, PERRIS, CA. FILED 10-11-2011.

ANGELICA MAKINO

THE MARK CONSISTS OF STANDARD CHARACTERS WITHOUT CLAIM TO ANY PARTICULAR FONT, STYLE, SIZE, OR COLOR.
THE NAME "ANGELICA MAKINO" DOES NOT IDENTIFY A LIVING INDIVIDUAL.
FOR NUTRITIONAL SUPPLEMENTS IN THE FORM OF CAPSULES, TABLETS AND POWDER (U.S. CLS. 6, 18, 44, 46, 51 AND 52).
FIRST USE 9-4-1996; IN COMMERCE 9-4-1996.
MICHAEL GAAFAR, EXAMINING ATTORNEY

SN 85-444,701. AQUAVIT PHARMACEUTICALS, INC., DBA AQUAVIT PHARMACEUTICALS, INC., NEW YORK, NY. FILED 10-11-2011.

Inner B

THE MARK CONSISTS OF STANDARD CHARACTERS WITHOUT CLAIM TO ANY PARTICULAR FONT, STYLE, SIZE, OR COLOR.
NO CLAIM IS MADE TO THE EXCLUSIVE RIGHT TO USE "B", APART FROM THE MARK AS SHOWN.
FOR VITAMIN B AND VITAMIN B PREPARATIONS (U.S. CLS. 6, 18, 44, 46, 51 AND 52).
ANDREW LEASER, EXAMINING ATTORNEY

SN 85-444,726. WINDMILL HEALTH PRODUCTS LLC, WEST CALDWELL, NJ. FILED 10-11-2011.

YOUTH FACTORS

THE MARK CONSISTS OF STANDARD CHARACTERS WITHOUT CLAIM TO ANY PARTICULAR FONT, STYLE, SIZE, OR COLOR.
FOR DIETARY AND NUTRITIONAL SUPPLEMENTS (U.S. CLS. 6, 18, 44, 46, 51 AND 52).
FIRST USE 3-19-2010; IN COMMERCE 3-19-2010.
TAMARA FRAZIER, EXAMINING ATTORNEY

CLASS 5—(Continued).

SN 85-445,196. SEMPRAE LABORATORIES, INC., SADDLE BROOK, NJ. FILED 10-12-2011.

ZESTRA GLIDE

THE MARK CONSISTS OF STANDARD CHARACTERS WITHOUT CLAIM TO ANY PARTICULAR FONT, STYLE, SIZE, OR COLOR.
OWNER OF U.S. REG. NOS. 3,019,637, 3,222,491 AND 3,741,842.
FOR PERSONAL LUBRICANTS (U.S. CLS. 6, 18, 44, 46, 51 AND 52).
DAVID I, EXAMINING ATTORNEY

CLASS 5—(Continued).

SN 85-446,316. PACIFICHEALTH LABORATORIES, INC., MATAWAN, NJ. FILED 10-13-2011.

Myotrex

THE MARK CONSISTS OF STANDARD CHARACTERS WITHOUT CLAIM TO ANY PARTICULAR FONT, STYLE, SIZE, OR COLOR.
FOR DIETARY AND NUTRITIONAL SUPPLEMENTS; DIETARY SUPPLEMENTS FOR HUMAN CONSUMPTION (U.S. CLS. 6, 18, 44, 46, 51 AND 52).
PATRICIA EVANKO, EXAMINING ATTORNEY

SN 85-445,416. STUART CONSUMER PRODUCT LABS, INC., NEW YORK, NY. FILED 10-12-2011.

RESTORFIX

THE MARK CONSISTS OF STANDARD CHARACTERS WITHOUT CLAIM TO ANY PARTICULAR FONT, STYLE, SIZE, OR COLOR.
FOR DIETARY AND NUTRITIONAL SUPPLEMENTS; DIETARY FOOD SUPPLEMENTS; FOOD SUPPLEMENTS; HERBAL SUPPLEMENTS; HOMEOPATHIC SUPPLEMENTS; MINERAL SUPPLEMENTS; NUTRITIONAL SUPPLEMENTS; VITAMIN SUPPLEMENTS (U.S. CLS. 6, 18, 44, 46, 51 AND 52).
ERIN FALK, EXAMINING ATTORNEY

SN 85-446,317. GNP, INC., ELKHORN, NE. FILED 10-13-2011.

AYEASTA

THE MARK CONSISTS OF STANDARD CHARACTERS WITHOUT CLAIM TO ANY PARTICULAR FONT, STYLE, SIZE, OR COLOR.
FOR DIETARY AND NUTRITIONAL SUPPLEMENTS; DIETARY AND NUTRITIONAL SUPPLEMENTS CAUSING AN ANTIOXIDANT AND/OR PROBYOTIC EFFECT; DIETARY AND NUTRITIONAL SUPPLEMENTS HAVING AN ANTIOXIDANT AND/OR A YEAST (U.S. CLS. 6, 18, 44, 46, 51 AND 52).
JAMES GRIFFIN, EXAMINING ATTORNEY

SN 85-446,294. PACIFICHEALTH LABORATORIES, INC., MATAWAN, NJ. FILED 10-13-2011.

Melatrex

THE MARK CONSISTS OF STANDARD CHARACTERS WITHOUT CLAIM TO ANY PARTICULAR FONT, STYLE, SIZE, OR COLOR.
FOR DIETARY AND NUTRITIONAL SUPPLEMENTS; DIETARY SUPPLEMENTS FOR HUMAN CONSUMPTION (U.S. CLS. 6, 18, 44, 46, 51 AND 52).
PATRICIA EVANKO, EXAMINING ATTORNEY

SN 85-446,323. PACIFICHEALTH LABORATORIES, INC., MATAWAN, NJ. FILED 10-13-2011.

Remtrex

THE MARK CONSISTS OF STANDARD CHARACTERS WITHOUT CLAIM TO ANY PARTICULAR FONT, STYLE, SIZE, OR COLOR.
FOR DIETARY AND NUTRITIONAL SUPPLEMENTS; DIETARY SUPPLEMENTS FOR HUMAN CONSUMPTION (U.S. CLS. 6, 18, 44, 46, 51 AND 52).
PATRICIA EVANKO, EXAMINING ATTORNEY

CLASS 5—(Continued).

SN 85-446,346. PACIFICHEALTH LABORATORIES, INC.,
MATAWAN, NJ. FILED 10-13-2011.

Immuntrex

THE MARK CONSISTS OF STANDARD CHARACTERS
WITHOUT CLAIM TO ANY PARTICULAR FONT, STYLE,
SIZE, OR COLOR.

FOR DIETARY AND NUTRITIONAL SUPPLEMENTS;
DIETARY SUPPLEMENTS FOR HUMAN CONSUMP-
TION (U.S. CLS. 6, 18, 44, 46, 51 AND 52).

PATRICIA EVANKO, EXAMINING ATTORNEY

CLASS 5—(Continued).

SN 85-446,603. EZSTRIP, AKA NEURAL PATHWAYS, LLC,
VENTURA, CA. FILED 10-13-2011.

EZSTRIP

THE MARK CONSISTS OF STANDARD CHARACTERS
WITHOUT CLAIM TO ANY PARTICULAR FONT, STYLE,
SIZE, OR COLOR.

FOR ADHESIVE BANDAGES (U.S. CLS. 6, 18, 44, 46, 51
AND 52).

WENDY JUN, EXAMINING ATTORNEY

SN 85-446,486. BAYER AKTIENGESELLSCHAFT, LEVER-
KUSEN, FED REP GERMANY, FILED 10-13-2011.

TRODIXA

THE MARK CONSISTS OF STANDARD CHARACTERS
WITHOUT CLAIM TO ANY PARTICULAR FONT, STYLE,
SIZE, OR COLOR.

OWNER OF FED REP GERMANY REG. NO. 30366236,
DATED 2-24-2004, EXPIRES 12-31-2013.

OWNER OF U.S. REG. NO. 3,020,384.

FOR PHARMACEUTICAL PREPARATIONS AND SUB-
STANCES FOR THE PREVENTION AND TREATMENT
OF CARDIOVASCULAR DISEASES, STROKE, SYS-
TEMIC EMBOLISM, DEEP VEIN THROMBOSIS AND
PULMONARY EMBOLISM; ANTICOAGULANTS (U.S.
CLS. 6, 18, 44, 46, 51 AND 52).

ERIN FALK, EXAMINING ATTORNEY

SN 85-446,880. AKORN, INC., LAKE FOREST, IL. FILED 10-
13-2011.

KETODAY

THE MARK CONSISTS OF STANDARD CHARACTERS
WITHOUT CLAIM TO ANY PARTICULAR FONT, STYLE,
SIZE, OR COLOR.

FOR EYE DROPS; ORGANIC COMPOUNDS,
NAMELY, DISACCHARIDES SOLD AS INTEGRAL
COMPONENTS OF EYE DROPS, SALINE AND IRRI-
GATING SOLUTIONS FOR USE IN AND AROUND THE
EYE; PHARMACEUTICAL PREPARATIONS FOR THE
TREATMENT OF EYE DISEASES, ALLERGIES AND
CONDITIONS AND FOR THE SYMPTOMATIC RELIEF
OF EYE DISEASES, ALLERGIES AND CONDITIONS;
ANTIBIOTIC FOR THE TREATMENT OF OPHTHALMO-
LOGIC CONDITIONS, INFLAMMATIONS AND INFEC-
TIONS (U.S. CLS. 6, 18, 44, 46, 51 AND 52).

JESSICA A. POWERS, EXAMINING ATTORNEY

SN 85-446,493. SUPERNUS PHARMACEUTICALS, INC.,
ROCKVILLE, MD. FILED 10-13-2011.

TROKENDI

THE MARK CONSISTS OF STANDARD CHARACTERS
WITHOUT CLAIM TO ANY PARTICULAR FONT, STYLE,
SIZE, OR COLOR.

OWNER OF U.S. REG. NO. 3,775,652.

FOR PHARMACEUTICAL PREPARATIONS OR SUB-
STANCES FOR THE TREATMENT AND PREVENTION
OF CENTRAL NERVOUS SYSTEM AND PERIPHERAL
NERVOUS SYSTEM DISEASES AND DISORDERS, PSY-
CHIATRIC AND NEUROLOGICAL DISEASES AND DIS-
ORDERS (U.S. CLS. 6, 18, 44, 46, 51 AND 52).

JUSTINE D. PARKER, EXAMINING ATTORNEY

SN 85-447,114. VITAL ANIMAL HEALTH, LLC, COLORADO
SPRINGS, CO. FILED 10-13-2011.

VITAL-PROFEN

THE MARK CONSISTS OF STANDARD CHARACTERS
WITHOUT CLAIM TO ANY PARTICULAR FONT, STYLE,
SIZE, OR COLOR.

FOR PHARMACEUTICAL PRODUCTS, NAMELY, AN-
ALGESICS (U.S. CLS. 6, 18, 44, 46, 51 AND 52).

WON TEAK OH, EXAMINING ATTORNEY

CLASS 5—(Continued).

SN 85-447,174. HELSINN HEALTHCARE SA, 6912 LUGANO, SWITZERLAND, FILED 10-13-2011.

ORASSIST

THE MARK CONSISTS OF STANDARD CHARACTERS WITHOUT CLAIM TO ANY PARTICULAR FONT, STYLE, SIZE, OR COLOR.

FOR PHARMACEUTICAL PREPARATIONS FOR USE IN AND THE MANAGEMENT OF PAINFUL SYMPTOMS ASSOCIATED WITH ORAL LESIONS OF VARIOUS ETIOLOGIES, NAMELY ORAL MUCOSITIS AND STOMATITIS, IRRITATION DUE TO ORAL SURGERY, TRAUMATIC ULCERS CAUSED BY BRACES OR ILL-FITTING DENTURES OR CAUSED BY DISEASES, AND APHTHOUS ULCERS (U.S. CLS. 6, 18, 44, 46, 51 AND 52).
DAVID TOOLEY, EXAMINING ATTORNEY

CLASS 5—(Continued).

SN 85-447,758. CARDIUM THERAPEUTICS, INC., SAN DIEGO, CA. FILED 10-14-2011.

PIPPA

THE MARK CONSISTS OF STANDARD CHARACTERS WITHOUT CLAIM TO ANY PARTICULAR FONT, STYLE, SIZE, OR COLOR.

FOR DIETARY AND NUTRITIONAL SUPPLEMENTS; HERBAL SUPPLEMENTS; MEDICINAL HERBAL PREPARATIONS; NUTRACEUTICALS FOR USE AS A DIETARY SUPPLEMENT; PLANT EXTRACTS FOR MEDICAL, VETERINARY AND PHARMACEUTICAL PURPOSES; VITAMIN AND MINERAL PREPARATIONS FOR MEDICAL USE; VITAMIN AND MINERAL SUPPLEMENTS (U.S. CLS. 6, 18, 44, 46, 51 AND 52).
LINDA M. KING, EXAMINING ATTORNEY

SN 85-447,175. ALTAIRE PHARMACEUTICALS, INC., AQUEBOGUE, NY. FILED 10-13-2011.

iSolutions

THE MARK CONSISTS OF STANDARD CHARACTERS WITHOUT CLAIM TO ANY PARTICULAR FONT, STYLE, SIZE, OR COLOR.

FOR OPHTHALMIC PREPARATIONS; PHARMACEUTICAL PREPARATIONS FOR THE TREATMENT OF EYE DISEASES AND CONDITIONS (U.S. CLS. 6, 18, 44, 46, 51 AND 52).

HAI-LY LAM, EXAMINING ATTORNEY

SN 85-448,085. ISOICHEM CORPORATION, LAKE OSWEGO, OR. FILED 10-14-2011.

Love How You Feel

THE MARK CONSISTS OF STANDARD CHARACTERS WITHOUT CLAIM TO ANY PARTICULAR FONT, STYLE, SIZE, OR COLOR.

FOR NUTRITIONAL SUPPLEMENTS (U.S. CLS. 6, 18, 44, 46, 51 AND 52).

FIRST USE 5-16-2011; IN COMMERCE 5-16-2011.
ROSELLE HERRERA, EXAMINING ATTORNEY

SN 85-447,349. ORGANNICA, INC., BERWYN, IL. FILED 10-14-2011.

AIR-AIDE

THE MARK CONSISTS OF STANDARD CHARACTERS WITHOUT CLAIM TO ANY PARTICULAR FONT, STYLE, SIZE, OR COLOR.

FOR ALL-NATURAL ANTI-MICROBIAL SPRAY (U.S. CLS. 6, 18, 44, 46, 51 AND 52).

FIRST USE 10-4-2011; IN COMMERCE 10-9-2011.
KAREN K. BUSH, EXAMINING ATTORNEY

SN 85-448,107. HANGOVER PAINOVER, LLC, LOVELAND, CO. FILED 10-14-2011.

Hangover Painover

THE MARK CONSISTS OF STANDARD CHARACTERS WITHOUT CLAIM TO ANY PARTICULAR FONT, STYLE, SIZE, OR COLOR.

FOR DIETARY FOOD SUPPLEMENTS; VITAMINS (U.S. CLS. 6, 18, 44, 46, 51 AND 52).

JAY BESCH, EXAMINING ATTORNEY

CLASS 5—(Continued).

SN 85-448,174. LIFEICE LLC, NEW YORK, NY. FILED 10-14-2011.

LifeIce

THE MARK CONSISTS OF STANDARD CHARACTERS WITHOUT CLAIM TO ANY PARTICULAR FONT, STYLE, SIZE, OR COLOR.

FOR DIETARY AND NUTRITIONALLY FORTIFIED FOOD PRODUCTS ADAPTED FOR MEDICAL USE; FOOD FOR MEDICALLY RESTRICTED DIETS; FOODS FOR INDIVIDUALS WITH SPECIAL DIETARY REQUIREMENTS NECESSITATED BY MEDICAL TREATMENTS (U.S. CLS. 6, 18, 44, 46, 51 AND 52).

ELIZABETH HUGHITT, EXAMINING ATTORNEY

SN 85-448,181. LIFEICE LLC, NEW YORK, NY. FILED 10-14-2011.

A Frozen Source for Healthy Living

THE MARK CONSISTS OF STANDARD CHARACTERS WITHOUT CLAIM TO ANY PARTICULAR FONT, STYLE, SIZE, OR COLOR.

FOR DIETARY AND NUTRITIONALLY FORTIFIED FOOD PRODUCTS ADAPTED FOR MEDICAL USE; FOOD FOR MEDICALLY RESTRICTED DIETS; FOODS FOR INDIVIDUALS WITH SPECIAL DIETARY REQUIREMENTS NECESSITATED BY MEDICAL TREATMENTS (U.S. CLS. 6, 18, 44, 46, 51 AND 52).

ELIZABETH HUGHITT, EXAMINING ATTORNEY

SN 85-448,191. LIFEICE LLC, NEW YORK, NY. FILED 10-14-2011.



THE MARK CONSISTS OF AN ICE CUBE WITH A FRANGIPANI FLOWER GROWING OUT OF THE TOP OF THE ICE CUBE.

FOR DIETARY AND NUTRITIONALLY FORTIFIED FOOD PRODUCTS ADAPTED FOR MEDICAL USE; FOOD FOR MEDICALLY RESTRICTED DIETS; FOODS FOR INDIVIDUALS WITH SPECIAL DIETARY REQUIREMENTS NECESSITATED BY MEDICAL TREATMENTS (U.S. CLS. 6, 18, 44, 46, 51 AND 52).

ELIZABETH HUGHITT, EXAMINING ATTORNEY

CLASS 5—(Continued).

SN 85-448,195. ZUREX PHARMAGRA, LLC, MADISON, WI. FILED 10-14-2011.

ZURALAC

THE MARK CONSISTS OF STANDARD CHARACTERS WITHOUT CLAIM TO ANY PARTICULAR FONT, STYLE, SIZE, OR COLOR.

FOR ANTISEPTIC PREPARATIONS (U.S. CLS. 6, 18, 44, 46, 51 AND 52).

FIRST USE 10-4-2011; IN COMMERCE 10-4-2011.

CHRISTOPHER BUONGIORNO, EXAMINING ATTORNEY

SN 85-448,448. ALL STAR FOODS, INC., MT. PROSPECT, IL. FILED 10-16-2011.

Better Absorption Better Utilization Better You!

THE MARK CONSISTS OF STANDARD CHARACTERS WITHOUT CLAIM TO ANY PARTICULAR FONT, STYLE, SIZE, OR COLOR.

FOR ANIMAL FEED SUPPLEMENTS; DIETARY AND NUTRITIONAL SUPPLEMENTS; DIETARY FOOD SUPPLEMENTS; DIETARY SUPPLEMENTAL DRINKS; DIETARY SUPPLEMENTS; DIETARY SUPPLEMENTS FOR ANIMALS; DIETARY SUPPLEMENTS FOR HUMAN CONSUMPTION; FEED SUPPLEMENTS FOR PETS AND LIVESTOCK; FOOD SUPPLEMENTS; HERBAL SUPPLEMENTS; HOMEOPATHIC SUPPLEMENTS; NUTRITIONAL DRINKS FOR ANIMALS; NUTRITIONAL ENERGY BARS FOR USE AS A MEAL SUBSTITUTE; NUTRITIONAL OILS NOT FOR FOOD OR COSMETIC PURPOSES; NUTRITIONAL SUPPLEMENTS; NUTRITIONAL SUPPLEMENTS IN LOTION FORM SOLD AS A COMPONENT OF NUTRITIONAL SKIN CARE PRODUCTS; SOY PROTEIN FOR USE AS A NUTRITIONAL SUPPLEMENT IN VARIOUS POWDERED AND READY-TO-DRINK BEVERAGES (U.S. CLS. 6, 18, 44, 46, 51 AND 52).

FIRST USE 10-3-2011; IN COMMERCE 10-3-2011.

GEOFFREY FOSDICK, EXAMINING ATTORNEY

SN 85-448,603. ALBAUGH, INC., ANKENY, IA. FILED 10-17-2011.

BATTLE STAR

THE MARK CONSISTS OF STANDARD CHARACTERS WITHOUT CLAIM TO ANY PARTICULAR FONT, STYLE, SIZE, OR COLOR.

FOR PESTICIDES (U.S. CLS. 6, 18, 44, 46, 51 AND 52).

GEORGE LORENZO, EXAMINING ATTORNEY

CLASS 5—(Continued).

SN 85-448,665. ALBAUGH, INC., ANKENY, IA. FILED 10-17-2011.

FOMESTAR

THE MARK CONSISTS OF STANDARD CHARACTERS WITHOUT CLAIM TO ANY PARTICULAR FONT, STYLE, SIZE, OR COLOR.
FOR PESTICIDES (U.S. CLS. 6, 18, 44, 46, 51 AND 52).
GEORGE LORENZO, EXAMINING ATTORNEY

CLASS 5—(Continued).

SN 85-449,132. COREPHARMA, L.L.C., MIDDLESEX, NJ. FILED 10-17-2011.

HAFMETAX

THE MARK CONSISTS OF STANDARD CHARACTERS WITHOUT CLAIM TO ANY PARTICULAR FONT, STYLE, SIZE, OR COLOR.
FOR PHARMACEUTICALS AND PHARMACEUTICAL PREPARATIONS, NAMELY, ANALGESIC AND MUSCLE RELAXANTS (U.S. CLS. 6, 18, 44, 46, 51 AND 52).
HANNO RITTNER, EXAMINING ATTORNEY

SN 85-449,102. ROSS, TERRY L., OSAGE BEACH, MO. FILED 10-17-2011.

KO BODY'S

THE MARK CONSISTS OF STANDARD CHARACTERS WITHOUT CLAIM TO ANY PARTICULAR FONT, STYLE, SIZE, OR COLOR.
FOR NUTRITIONAL SUPPLEMENTS (U.S. CLS. 6, 18, 44, 46, 51 AND 52).
FRED CARL, EXAMINING ATTORNEY

SN 85-449,165. IMMUNOVACCINE TECHNOLOGIES INC., HALIFAX, NOVA SCOTIA, CANADA, FILED 10-17-2011.

DEPOVAX

THE MARK CONSISTS OF STANDARD CHARACTERS WITHOUT CLAIM TO ANY PARTICULAR FONT, STYLE, SIZE, OR COLOR.
FOR VACCINES USED FOR APPLICATIONS TO HUMAN AND ANIMAL BIOLOGICAL PROCESSES (U.S. CLS. 6, 18, 44, 46, 51 AND 52).
DOMINIC FATHY, EXAMINING ATTORNEY

SN 85-449,122. COMERCIALIZADORA MD, S.A. DE C.V., ZAPOPAN, JALISCO, MEXICO, FILED 10-17-2011.

DIABELIVE

THE MARK CONSISTS OF STANDARD CHARACTERS WITHOUT CLAIM TO ANY PARTICULAR FONT, STYLE, SIZE, OR COLOR.
FOR DIETARY SUPPLEMENTS (U.S. CLS. 6, 18, 44, 46, 51 AND 52).
BRIAN CALLAGHAN, EXAMINING ATTORNEY

SN 85-449,173. IT WORKS MARKETING, INC., BRADENTON, FL. FILED 10-17-2011.

Ultimate ProFit

THE MARK CONSISTS OF STANDARD CHARACTERS WITHOUT CLAIM TO ANY PARTICULAR FONT, STYLE, SIZE, OR COLOR.
FOR POWDERED PROTEIN AND MEAL REPLACEMENT SHAKE MIXES FOR HUMAN CONSUMPTION (U.S. CLS. 6, 18, 44, 46, 51 AND 52).
SANI KHOURI, EXAMINING ATTORNEY

CLASS 5—(Continued).

SN 85-449,269. GEOFFREY REILINGER, DBA P-FRESH, BOSTON, MA. FILED 10-17-2011.

P-Fresh

THE MARK CONSISTS OF STANDARD CHARACTERS WITHOUT CLAIM TO ANY PARTICULAR FONT, STYLE, SIZE, OR COLOR.

FOR ANIMAL FEED SUPPLEMENTS (U.S. CLS. 6, 18, 44, 46, 51 AND 52).

STEVEN JACKSON, EXAMINING ATTORNEY

SN 85-449,318. SAENZ CORPORATION, FULLERTON, CA. FILED 10-17-2011.

Bivanta

THE MARK CONSISTS OF STANDARD CHARACTERS WITHOUT CLAIM TO ANY PARTICULAR FONT, STYLE, SIZE, OR COLOR.

FOR DIETARY FOOD SUPPLEMENTS; NUTRITIONAL SUPPLEMENTS, NAMELY, PROBIOTIC COMPOSITIONS (U.S. CLS. 6, 18, 44, 46, 51 AND 52).

MATTHEW PAPPAS, EXAMINING ATTORNEY

SN 85-449,410. ROSINKE, PLATO, NEW YORK, NY. FILED 10-18-2011.



NO CLAIM IS MADE TO THE EXCLUSIVE RIGHT TO USE "PROSTATE", APART FROM THE MARK AS SHOWN. THE COLOR(S) GREEN AND WHITE IS/ARE CLAIMED AS A FEATURE OF THE MARK.

THE MARK CONSISTS OF THE WORDING "PROSTATE MAGIC" IN GREEN, WITH A GREEN LEAF ABOVE THE LETTER "I", ALL SURROUNDED BY A GREEN RECTANGULAR BORDER ON A GREEN AND WHITE BACKGROUND WITH FAINT GREEN LEAVES.

FOR DIETARY AND NUTRITIONAL SUPPLEMENTS; DIETARY FOOD SUPPLEMENTS; DIETARY SUPPLEMENTS FOR HUMAN CONSUMPTION; DIETARY SUPPLEMENTS FOR URINARY HEALTH; FOOD SUPPLEMENTS; HERBAL SUPPLEMENTS; HERBAL SUPPLEMENTS FOR PROSTATE SUPPORT; NATURAL HERBAL SUPPLEMENTS; NATURAL SUPPLEMENTS FOR TREATING ERECTILE DYSFUNCTION (U.S. CLS. 6, 18, 44, 46, 51 AND 52).

FIRST USE 6-27-2003; IN COMMERCE 6-27-2003. KRISTIN DAHLING, EXAMINING ATTORNEY

CLASS 5—(Continued).

SN 85-449,424. HEUER M.D. RESEARCH, INC., ORLANDO, FL. FILED 10-18-2011.

CARDIASLIM

THE MARK CONSISTS OF STANDARD CHARACTERS WITHOUT CLAIM TO ANY PARTICULAR FONT, STYLE, SIZE, OR COLOR.

FOR DIETARY AND NUTRITIONAL SUPPLEMENTS; DIETARY AND NUTRITIONAL SUPPLEMENTS USED FOR WEIGHT LOSS; DIETARY FOOD SUPPLEMENTS; DIETARY SUPPLEMENTS; DIETARY SUPPLEMENTS FOR HUMAN CONSUMPTION; DIETARY SUPPLEMENTS IN THE NATURE OF WEIGHT LOSS POWDERS (U.S. CLS. 6, 18, 44, 46, 51 AND 52).

SUSAN RICHARDS, EXAMINING ATTORNEY

SN 85-449,521. PADDOCK LABORATORIES, LLC., NEW HOPE, MN. FILED 10-18-2011.

CLENZ-LYTE

THE MARK CONSISTS OF STANDARD CHARACTERS WITHOUT CLAIM TO ANY PARTICULAR FONT, STYLE, SIZE, OR COLOR.

FOR BOWEL CLEANSING AGENT FOR USE IN HUMANS (U.S. CLS. 6, 18, 44, 46, 51 AND 52).

CURTIS FRENCH, EXAMINING ATTORNEY

SN 85-449,537. CD DIAGNOSTICS, BLUE BELL, PA. FILED 10-18-2011.

CD DIAGNOSTICS

THE MARK CONSISTS OF STANDARD CHARACTERS WITHOUT CLAIM TO ANY PARTICULAR FONT, STYLE, SIZE, OR COLOR.

NO CLAIM IS MADE TO THE EXCLUSIVE RIGHT TO USE "DIAGNOSTICS", APART FROM THE MARK AS SHOWN.

FOR IN VITRO MEDICAL DIAGNOSTIC TEST KITS COMPRISED PRIMARILY OF MEDICAL DIAGNOSTIC REAGENTS AND ONE OR MORE OF THE FOLLOWING, NAMELY, PIPETTES, CASSETTES, COLLECTION VESSELS, TEST STRIPS, AND SWABS (U.S. CLS. 6, 18, 44, 46, 51 AND 52).

CHRISTOPHER LAW, EXAMINING ATTORNEY

CLASS 5—(Continued).

SN 85-449,674. BIOLIFE, LLC, SARASOTA, FL. FILED 10-18-2011.

StatSeal

THE MARK CONSISTS OF STANDARD CHARACTERS WITHOUT CLAIM TO ANY PARTICULAR FONT, STYLE, SIZE, OR COLOR.

FOR NON-PRESCRIPTION PHARMACEUTICAL PREPARATIONS, NAMELY, NON-ABSORBABLE TOPICAL POWDER APPLIED EXTERNALLY TO SEAL AND PROTECT VASCULAR ACCESS SITES AND OTHER EXTERNAL WOUNDS (U.S. CLS. 6, 18, 44, 46, 51 AND 52).

KIMBERLY FRYE, EXAMINING ATTORNEY

CLASS 5—(Continued).

SN 85-449,845. INSIGHT PHARMACEUTICALS LLC, LANGHORNE, PA. FILED 10-18-2011.

URISTAT

THE MARK CONSISTS OF STANDARD CHARACTERS WITHOUT CLAIM TO ANY PARTICULAR FONT, STYLE, SIZE, OR COLOR.

OWNER OF U.S. REG. NO. 2,070,690.
FOR ANALGESICS; MEDICAL DIAGNOSTIC TEST STRIPS FOR USE IN THE FIELD OF URINARY TRACT INFECTIONS (U.S. CLS. 6, 18, 44, 46, 51 AND 52).
SETH A. RAPPAPORT, EXAMINING ATTORNEY

SN 85-449,735. BIG ISLAND SKIN CARE, LLC, DBA BIG ISLAND SKIN CARE, EXCELSIOR, MN. FILED 10-18-2011.

Enzpire

THE MARK CONSISTS OF STANDARD CHARACTERS WITHOUT CLAIM TO ANY PARTICULAR FONT, STYLE, SIZE, OR COLOR.

FOR HOMEOPATHIC SUPPLEMENTS (U.S. CLS. 6, 18, 44, 46, 51 AND 52).
FIRST USE 10-1-2011; IN COMMERCE 10-1-2011.
DOMINIC J. FERRAIUOLO, EXAMINING ATTORNEY

SN 85-449,764. HAMIDA PHARMA INC., LAKE FOREST, CA. FILED 10-18-2011.

FIBROMYA

THE MARK CONSISTS OF STANDARD CHARACTERS WITHOUT CLAIM TO ANY PARTICULAR FONT, STYLE, SIZE, OR COLOR.

FOR DIETARY FOOD SUPPLEMENTS (U.S. CLS. 6, 18, 44, 46, 51 AND 52).
FIRST USE 1-1-2000; IN COMMERCE 1-1-2000.
HELENE LIWINSKI, EXAMINING ATTORNEY

SN 85-450,071. PARAGON TRADE BRANDS, LLC, GREAT NECK, NY. FILED 10-18-2011.

SOFT-STRETCH

THE MARK CONSISTS OF STANDARD CHARACTERS WITHOUT CLAIM TO ANY PARTICULAR FONT, STYLE, SIZE, OR COLOR.

OWNER OF U.S. REG. NO. 1,590,837.
FOR ADULT INCONTINENCE UNDERWEAR AND BRIEFS (U.S. CLS. 6, 18, 44, 46, 51 AND 52).
KAREN K. BUSH, EXAMINING ATTORNEY

SN 85-450,251. THORNE RESEARCH, INC., SANDPOINT, ID. FILED 10-18-2011.

Methyl-Guard Plus

THE MARK CONSISTS OF STANDARD CHARACTERS WITHOUT CLAIM TO ANY PARTICULAR FONT, STYLE, SIZE, OR COLOR.

OWNER OF U.S. REG. NO. 2,178,525.
FOR NUTRITIONAL SUPPLEMENTS FOR PROVIDING HOMOCYSTEINE METHYLATION COFACTORS (U.S. CLS. 6, 18, 44, 46, 51 AND 52).
FIRST USE 3-2-2011; IN COMMERCE 3-2-2011.
MARLENE BELL, EXAMINING ATTORNEY

CLASS 5—(Continued).

SN 85-450,402. HELMER, MAX, HENDERSON, NV. FILED 10-18-2011.

RaverSaverz

THE MARK CONSISTS OF STANDARD CHARACTERS WITHOUT CLAIM TO ANY PARTICULAR FONT, STYLE, SIZE, OR COLOR.

FOR DIETARY SUPPLEMENTS (U.S. CLS. 6, 18, 44, 46, 51 AND 52).
REBECCA POVARCHUK, EXAMINING ATTORNEY

CLASS 5—(Continued).

SN 85-452,790. NOVARTIS AG, BASEL, SWITZERLAND, FILED 10-21-2011.

REVNIOM

SN 85-452,788. NOVARTIS AG, BASEL, SWITZERLAND, FILED 10-21-2011.

FLITURE

THE MARK CONSISTS OF STANDARD CHARACTERS WITHOUT CLAIM TO ANY PARTICULAR FONT, STYLE, SIZE, OR COLOR.

OWNER OF U.S. REG. NO. 3,228,117.
FOR ANTI-INFECTIVES; ANTI-INFLAMMATORIES; ANTIBIOTICS; ANTIFUNGAL PREPARATIONS; ANTIVIRALS; CARDIOVASCULAR PHARMACEUTICALS; PHARMACEUTICAL PREPARATIONS ACTING ON THE CENTRAL NERVOUS SYSTEM; PHARMACEUTICAL PREPARATIONS FOR THE PREVENTION AND TREATMENT OF OCULAR DISORDERS OR DISEASES, BACTERIA-BASED DISEASES OR DISORDERS, AUTOIMMUNE DISEASES OR DISORDERS, KIDNEY DISEASES OR DISORDERS, AND DIABETES; PHARMACEUTICAL PREPARATIONS FOR THE TREATMENT OF IMMUNE SYSTEM RELATED DISEASES AND DISORDERS; PHARMACEUTICAL PREPARATIONS FOR USE IN DERMATOLOGY; PHARMACEUTICAL PREPARATIONS FOR THE TREATMENT AND PREVENTION OF DISORDERS OF THE METABOLIC SYSTEM, THE MUSCULO-SKELETAL SYSTEM, THE GENITOURINARY SYSTEM AND FOR THE TREATMENT OF INFLAMMATORY DISORDERS; PHARMACEUTICAL PREPARATIONS FOR USE IN ONCOLOGY AND HEMATOLOGY AND IN TISSUE AND ORGAN TRANSPLANTATION; PHARMACEUTICAL PREPARATIONS FOR THE PREVENTION AND TREATMENT OF GASTROENTEROLOGICAL DISORDERS; PHARMACEUTICAL PRODUCTS FOR OPHTHALMOLOGICAL USE; PHARMACEUTICAL PRODUCTS FOR TREATING RESPIRATORY DISEASES (U.S. CLS. 6, 18, 44, 46, 51 AND 52).
SANJEEV VOHRA, EXAMINING ATTORNEY

THE MARK CONSISTS OF STANDARD CHARACTERS WITHOUT CLAIM TO ANY PARTICULAR FONT, STYLE, SIZE, OR COLOR.

OWNER OF U.S. REG. NO. 3,247,828.
FOR ANTI-INFECTIVES; ANTI-INFLAMMATORIES; ANTIBIOTICS; ANTIFUNGAL PREPARATIONS; ANTIVIRALS; CARDIOVASCULAR PHARMACEUTICALS; DIAGNOSTIC PREPARATIONS FOR MEDICAL PURPOSES; PHARMACEUTICAL PREPARATIONS ACTING ON THE CENTRAL NERVOUS SYSTEM; PHARMACEUTICAL PREPARATIONS FOR THE PREVENTION AND TREATMENT OF OCULAR DISORDERS OR DISEASES, BACTERIA-BASED DISEASES OR DISORDERS, AUTOIMMUNE DISEASES OR DISORDERS, KIDNEY DISEASES OR DISORDERS, AND DIABETES; PHARMACEUTICAL PREPARATIONS FOR THE TREATMENT OF IMMUNE SYSTEM RELATED DISEASES AND DISORDERS; PHARMACEUTICAL PREPARATIONS FOR USE IN DERMATOLOGY; PHARMACEUTICAL PREPARATIONS FOR THE TREATMENT AND PREVENTION OF DISORDERS OF THE METABOLIC SYSTEM, THE MUSCULO-SKELETAL SYSTEM, THE GENITOURINARY SYSTEM AND FOR THE TREATMENT OF INFLAMMATORY DISORDERS; PHARMACEUTICAL PREPARATIONS FOR USE IN ONCOLOGY AND HEMATOLOGY AND IN TISSUE AND ORGAN TRANSPLANTATION; PHARMACEUTICAL PREPARATIONS FOR THE PREVENTION AND TREATMENT OF GASTROENTEROLOGICAL DISORDERS; PHARMACEUTICAL PRODUCTS FOR OPHTHALMOLOGICAL USE; PHARMACEUTICAL PRODUCTS FOR TREATING RESPIRATORY DISEASES; VACCINES (U.S. CLS. 6, 18, 44, 46, 51 AND 52).
SANJEEV VOHRA, EXAMINING ATTORNEY

CLASS 5—(Continued).

SN 85-452,791. NOVARTIS AG, BASEL, SWITZERLAND,
FILED 10-21-2011.

OPRETIR

THE MARK CONSISTS OF STANDARD CHARACTERS
WITHOUT CLAIM TO ANY PARTICULAR FONT, STYLE,
SIZE, OR COLOR.

OWNER OF U.S. REG. NO. 3,252,059.

FOR ANTI-INFECTIVES; ANTI-INFLAMMATORIES;
ANTIBIOTICS; ANTIFUNGAL PREPARATIONS; ANTI-
VIRALS; CARDIOVASCULAR PHARMACEUTICALS;
DIAGNOSTIC PREPARATIONS FOR MEDICAL PUR-
POSES; PHARMACEUTICAL PREPARATIONS ACTING
ON THE CENTRAL NERVOUS SYSTEM; PHARMACEU-
TICAL PREPARATIONS FOR THE PREVENTION AND
TREATMENT OF OCULAR DISORDERS OR DISEASES,
BACTERIA-BASED DISEASES OR DISORDERS, AUTO-
IMMUNE DISEASES OR DISORDERS, KIDNEY DIS-
EASES OR DISORDERS, AND DIABETES;
PHARMACEUTICAL PREPARATIONS FOR THE
TREATMENT OF IMMUNE SYSTEM RELATED DIS-
EASES AND DISORDERS; PHARMACEUTICAL PRE-
PARATIONS FOR USE IN DERMATOLOGY;
PHARMACEUTICAL PREPARATIONS FOR THE
TREATMENT AND PREVENTION OF DISORDERS OF
THE METABOLIC SYSTEM, THE MUSCULO-SKELETAL
SYSTEM, THE GENITOURINARY SYSTEM AND FOR
THE TREATMENT OF INFLAMMATORY DISORDERS;
PHARMACEUTICAL PREPARATIONS FOR USE IN
ONCOLOGY AND HEMATOLOGY AND IN TISSUE
AND ORGAN TRANSPLANTATION; PHARMACEUTI-
CAL PREPARATIONS FOR THE PREVENTION AND
TREATMENT OF GASTROENTEROLOGICAL DISOR-
DERS; PHARMACEUTICAL PRODUCTS FOR
OPHTHALMOLOGICAL USE; PHARMACEUTICAL PRO-
DUCTS FOR TREATING RESPIRATORY DISEASES;
VACCINES (U.S. CLS. 6, 18, 44, 46, 51 AND 52).

SANJEEV VOHRA, EXAMINING ATTORNEY

CLASS 5—(Continued).

SN 85-452,793. NOVARTIS AG, BASEL, SWITZERLAND,
FILED 10-21-2011.

OLAMBIA

THE MARK CONSISTS OF STANDARD CHARACTERS
WITHOUT CLAIM TO ANY PARTICULAR FONT, STYLE,
SIZE, OR COLOR.

OWNER OF U.S. REG. NO. 3,547,098.

FOR ANTI-INFECTIVES; ANTI-INFLAMMATORIES;
ANTIBIOTICS; ANTIFUNGAL PREPARATIONS; ANTI-
VIRALS; CARDIOVASCULAR PHARMACEUTICALS;
DIAGNOSTIC PREPARATIONS FOR MEDICAL PUR-
POSES; PHARMACEUTICAL PREPARATIONS ACTING
ON THE CENTRAL NERVOUS SYSTEM; PHARMACEU-
TICAL PREPARATIONS FOR THE PREVENTION AND
TREATMENT OF OCULAR DISORDERS OR DISEASES,
BACTERIA-BASED DISEASES OR DISORDERS, AUTO-
IMMUNE DISEASES OR DISORDERS, KIDNEY DIS-
EASES OR DISORDERS, AND DIABETES;
PHARMACEUTICAL PREPARATIONS FOR THE
TREATMENT OF IMMUNE SYSTEM RELATED DIS-
EASES AND DISORDERS; PHARMACEUTICAL PRE-
PARATIONS FOR USE IN DERMATOLOGY;
PHARMACEUTICAL PREPARATIONS FOR THE
TREATMENT AND PREVENTION OF DISORDERS OF
THE METABOLIC SYSTEM, THE MUSCULO-SKELETAL
SYSTEM, THE GENITOURINARY SYSTEM AND FOR
THE TREATMENT OF INFLAMMATORY DISORDERS;
PHARMACEUTICAL PREPARATIONS FOR USE IN
ONCOLOGY AND HEMATOLOGY AND IN TISSUE
AND ORGAN TRANSPLANTATION; PHARMACEUTI-
CAL PREPARATIONS FOR THE PREVENTION AND
TREATMENT OF GASTROENTEROLOGICAL DISOR-
DERS; PHARMACEUTICAL PRODUCTS FOR
OPHTHALMOLOGICAL USE; PHARMACEUTICAL PRO-
DUCTS FOR TREATING RESPIRATORY DISEASES;
VACCINES (U.S. CLS. 6, 18, 44, 46, 51 AND 52).

SANJEEV VOHRA, EXAMINING ATTORNEY

SN 85-453,817. THE MRS. FIELDS' BRAND, INC., SALT
LAKE CITY, UT. FILED 10-22-2011.

PRIMITIVE SNACKS

THE MARK CONSISTS OF STANDARD CHARACTERS
WITHOUT CLAIM TO ANY PARTICULAR FONT, STYLE,
SIZE, OR COLOR.

NO CLAIM IS MADE TO THE EXCLUSIVE RIGHT TO
USE "SNACKS", APART FROM THE MARK AS SHOWN.

FOR DIETARY BEVERAGE SUPPLEMENTS FOR HU-
MAN CONSUMPTION IN LIQUID AND DRY MIX
FORM FOR THERAPEUTIC PURPOSES; DIETARY SUP-
PLEMENTAL DRINKS; DIETARY SUPPLEMENTAL
DRINKS IN THE NATURE OF VITAMIN AND MINER-
AL BEVERAGES; MEAL REPLACEMENT BARS; POW-
DERED NUTRITIONAL SUPPLEMENT DRINK MIX
AND CONCENTRATE; PROTEIN SUPPLEMENTS;
WHEY PROTEIN SUPPLEMENTS (U.S. CLS. 6, 18, 44,
46, 51 AND 52).

HANNO RITTNER, EXAMINING ATTORNEY

CLASS 5—(Continued).

SN 85-454,369. THE MRS. FIELDS' BRAND, INC., SALT LAKE CITY, UT. FILED 10-24-2011.

PRIMITIVE ENERGY

THE MARK CONSISTS OF STANDARD CHARACTERS WITHOUT CLAIM TO ANY PARTICULAR FONT, STYLE, SIZE, OR COLOR.

NO CLAIM IS MADE TO THE EXCLUSIVE RIGHT TO USE "ENERGY", APART FROM THE MARK AS SHOWN.

FOR DIETARY BEVERAGE SUPPLEMENTS FOR HUMAN CONSUMPTION IN LIQUID AND DRY MIX FORM FOR THERAPEUTIC PURPOSES; DIETARY SUPPLEMENTAL DRINKS; DIETARY SUPPLEMENTAL DRINKS IN THE NATURE OF VITAMIN AND MINERAL BEVERAGES; MEAL REPLACEMENT BARS; POWDERED NUTRITIONAL SUPPLEMENT DRINK MIX AND CONCENTRATE; PROTEIN SUPPLEMENTS; WHEY PROTEIN SUPPLEMENTS (U.S. CLS. 6, 18, 44, 46, 51 AND 52).

HANNO RITTNER, EXAMINING ATTORNEY

SN 85-457,567. NOVARTIS AG, BASEL, SWITZERLAND, FILED 10-27-2011.

OPHIDEL

THE MARK CONSISTS OF STANDARD CHARACTERS WITHOUT CLAIM TO ANY PARTICULAR FONT, STYLE, SIZE, OR COLOR.

FOR ANTI-INFECTIVES; ANTI-INFLAMMATORIES; ANTIBIOTICS; ANTIFUNGAL PREPARATIONS; ANTIVIRALS; CARDIOVASCULAR PHARMACEUTICALS; PHARMACEUTICAL PREPARATIONS ACTING ON THE CENTRAL NERVOUS SYSTEM; PHARMACEUTICAL PREPARATIONS FOR THE PREVENTION AND TREATMENT OF OCULAR DISORDERS OR DISEASES, BACTERIA-BASED DISEASES OR DISORDERS, AUTOIMMUNE DISEASES OR DISORDERS, KIDNEY DISEASES OR DISORDERS, AND DIABETES; PHARMACEUTICAL PREPARATIONS FOR THE TREATMENT OF IMMUNE SYSTEM RELATED DISEASES AND DISORDERS; PHARMACEUTICAL PREPARATIONS FOR USE IN DERMATOLOGY; PHARMACEUTICAL PREPARATIONS FOR THE TREATMENT AND PREVENTION OF DISORDERS OF THE METABOLIC SYSTEM, THE MUSCULO-SKELETAL SYSTEM, THE GENITOURINARY SYSTEM AND FOR THE TREATMENT OF INFLAMMATORY DISORDERS; PHARMACEUTICAL PREPARATIONS FOR USE IN ONCOLOGY AND HEMATOLOGY AND IN TISSUE AND ORGAN TRANSPLANTATION; PHARMACEUTICAL PREPARATIONS FOR THE PREVENTION AND TREATMENT OF GASTROENTEROLOGICAL DISORDERS; PHARMACEUTICAL PRODUCTS FOR OPHTHALMOLOGICAL USE; PHARMACEUTICAL PRODUCTS FOR TREATING RESPIRATORY DISEASES (U.S. CLS. 6, 18, 44, 46, 51 AND 52).

SANJEEV VOHRA, EXAMINING ATTORNEY

CLASS 5—(Continued).

SN 85-457,569. NOVARTIS AG, BASEL, SWITZERLAND, FILED 10-27-2011.

UPERIO

THE MARK CONSISTS OF STANDARD CHARACTERS WITHOUT CLAIM TO ANY PARTICULAR FONT, STYLE, SIZE, OR COLOR.

FOR ANTI-INFECTIVES; ANTI-INFLAMMATORIES; ANTIBIOTICS; ANTIFUNGAL PREPARATIONS; ANTIVIRALS; CARDIOVASCULAR PHARMACEUTICALS; PHARMACEUTICAL PREPARATIONS ACTING ON THE CENTRAL NERVOUS SYSTEM; PHARMACEUTICAL PREPARATIONS FOR THE PREVENTION AND TREATMENT OF OCULAR DISORDERS OR DISEASES, BACTERIA-BASED DISEASES OR DISORDERS, AUTOIMMUNE DISEASES OR DISORDERS, KIDNEY DISEASES OR DISORDERS, AND DIABETES; PHARMACEUTICAL PREPARATIONS FOR THE TREATMENT OF IMMUNE SYSTEM RELATED DISEASES AND DISORDERS; PHARMACEUTICAL PREPARATIONS FOR USE IN DERMATOLOGY; PHARMACEUTICAL PREPARATIONS FOR THE TREATMENT AND PREVENTION OF DISORDERS OF THE METABOLIC SYSTEM, THE MUSCULO-SKELETAL SYSTEM, THE GENITOURINARY SYSTEM AND FOR THE TREATMENT OF INFLAMMATORY DISORDERS; PHARMACEUTICAL PREPARATIONS FOR USE IN ONCOLOGY AND HEMATOLOGY AND IN TISSUE AND ORGAN TRANSPLANTATION; PHARMACEUTICAL PREPARATIONS FOR THE PREVENTION AND TREATMENT OF GASTROENTEROLOGICAL DISORDERS; PHARMACEUTICAL PRODUCTS FOR OPHTHALMOLOGICAL USE; PHARMACEUTICAL PRODUCTS FOR TREATING RESPIRATORY DISEASES (U.S. CLS. 6, 18, 44, 46, 51 AND 52).

SANJEEV VOHRA, EXAMINING ATTORNEY

SN 85-458,745. BAYER AKTIENGESELLSCHAFT, LEVERKUSEN, FED REP GERMANY, FILED 10-28-2011.

VELDYS

THE MARK CONSISTS OF STANDARD CHARACTERS WITHOUT CLAIM TO ANY PARTICULAR FONT, STYLE, SIZE, OR COLOR.

FOR PHARMACEUTICAL PREPARATIONS FOR THE TREATMENT OF VULVOVAGINAL ATROPHY (U.S. CLS. 6, 18, 44, 46, 51 AND 52).

ERIN FALK, EXAMINING ATTORNEY

CLASS 5—(Continued).

SN 85-460,319. LG LIFE SCIENCES, LTD., SEOUL, REPUBLIC OF KOREA, FILED 10-31-2011.

INTERPRO

THE MARK CONSISTS OF STANDARD CHARACTERS WITHOUT CLAIM TO ANY PARTICULAR FONT, STYLE, SIZE, OR COLOR.

OWNER OF REPUBLIC OF KOREA REG. NO. 0570303, DATED 12-30-2003, EXPIRES 12-30-2013.

OWNER OF U.S. REG. NO. 3,007,188.

FOR PHARMACEUTICAL PREPARATIONS FOR TREATING CANCERS, NAMELY, HAIRY CELL LEUKEMIA, KAPOSI'S SARCOMA, MULTIPLE MYELOMA, CHRONIC MYELOGENOUS LEUKEMIA, MALIGNANT MELANOMA; PHARMACEUTICAL PREPARATIONS FOR REGULATING IMMUNE SYSTEM; PHARMACEUTICAL PREPARATIONS FOR TREATING HEPATITIS-CHRONIC HEPATITIS B, CHRONIC HEPATITIS C, ALL THE AFORESAID GOODS BEING FOR HUMANS (U.S. CLS. 6, 18, 44, 46, 51 AND 52).

JOHN WILKE, EXAMINING ATTORNEY

CLASS 5—(Continued).

SN 85-465,276. PROTICA INC., WHITEHALL, PA. FILED 11-4-2011.

Mr Waffles

THE MARK CONSISTS OF STANDARD CHARACTERS WITHOUT CLAIM TO ANY PARTICULAR FONT, STYLE, SIZE, OR COLOR.

FOR DIETARY AND NUTRITIONAL SUPPLEMENTS (U.S. CLS. 6, 18, 44, 46, 51 AND 52).

ALEXANDER L. POWERS, EXAMINING ATTORNEY

SN 85-461,200. COREPHARMA, L.L.C., MIDDLESEX, NJ. FILED 11-1-2011.



THE COLOR(S) LIGHT BLUE AND BLUE IS/ARE CLAIMED AS A FEATURE OF THE MARK.

THE MARK CONSISTS OF THE STYLIZED WORD "HAFMETAX" WHEREIN THE PORTION "HAF" IS IN LIGHT BLUE AND THE PORTION "METAX" IS IN A DARKER SHADE OF BLUE, WITH A LINE DISSECTING THE LETTER "X" WITH THE LOWER RIGHT PORTION OF THE "X" EXTENDING DOWN BELOW THE BOTTOM OF THE WORD "HAFMETAX".

FOR PHARMACEUTICALS AND PHARMACEUTICAL PREPARATIONS, NAMELY, ANALGESIC AND MUSCLE RELAXANTS (U.S. CLS. 6, 18, 44, 46, 51 AND 52).

HANNO RITTNER, EXAMINING ATTORNEY

SN 85-466,617. THORNE RESEARCH, INC., SANDPOINT, ID. FILED 11-7-2011.

GASTRIPLEX

THE MARK CONSISTS OF STANDARD CHARACTERS WITHOUT CLAIM TO ANY PARTICULAR FONT, STYLE, SIZE, OR COLOR.

FOR NUTRITIONAL SUPPLEMENTS TO PROVIDE GASTROINTESTINAL SUPPORT FOR COMPANION ANIMALS, NAMELY, DOGS, CATS, AND HORSES (U.S. CLS. 6, 18, 44, 46, 51 AND 52).

FIRST USE 6-1-2010; IN COMMERCE 6-1-2010.

MARLENE BELL, EXAMINING ATTORNEY

SN 85-461,208. COREPHARMA, L.L.C., MIDDLESEX, NJ. FILED 11-1-2011.



THE MARK CONSISTS OF THE STYLIZED WORD "HAFMETAX" WITH A LINE DISSECTING THE LETTER "X" WITH THE LOWER RIGHT PORTION OF THE "X" EXTENDING DOWN BELOW THE BOTTOM OF THE WORD "HAFMETAX".

FOR PHARMACEUTICALS AND PHARMACEUTICAL PREPARATIONS, NAMELY, ANALGESIC AND MUSCLE RELAXANTS (U.S. CLS. 6, 18, 44, 46, 51 AND 52).

HANNO RITTNER, EXAMINING ATTORNEY

SN 85-466,619. THORNE RESEARCH, INC., SANDPOINT, ID. FILED 11-7-2011.

IMMUGEN

THE MARK CONSISTS OF STANDARD CHARACTERS WITHOUT CLAIM TO ANY PARTICULAR FONT, STYLE, SIZE, OR COLOR.

FOR NUTRITIONAL SUPPLEMENTS TO PROVIDE IMMUNE SUPPORT FOR COMPANION ANIMALS, NAMELY, DOGS AND CATS (U.S. CLS. 6, 18, 44, 46, 51 AND 52).

FIRST USE 6-1-2010; IN COMMERCE 6-1-2010.

MARLENE BELL, EXAMINING ATTORNEY

CLASS 5—(Continued).

SN 85-466,623. THORNE RESEARCH, INC., SANDPOINT, ID.
FILED 11-7-2011.

HEPAGEN-C

THE MARK CONSISTS OF STANDARD CHARACTERS WITHOUT CLAIM TO ANY PARTICULAR FONT, STYLE, SIZE, OR COLOR.

FOR NUTRITIONAL SUPPLEMENTS TO PROVIDE HEPATIC SUPPORT FOR COMPANION ANIMALS, NAMELY, DOGS (U.S. CLS. 6, 18, 44, 46, 51 AND 52).
FIRST USE 6-1-2010; IN COMMERCE 6-1-2010.
MARLENE BELL, EXAMINING ATTORNEY

CLASS 5—(Continued).

SN 85-467,522. THORNE RESEARCH, INC., SANDPOINT, ID.
FILED 11-8-2011.

PERFUSIA PLUS

THE MARK CONSISTS OF STANDARD CHARACTERS WITHOUT CLAIM TO ANY PARTICULAR FONT, STYLE, SIZE, OR COLOR.

OWNER OF U.S. REG. NO. 3,029,880.
FOR NUTRITIONAL SUPPLEMENTS (U.S. CLS. 6, 18, 44, 46, 51 AND 52).
FIRST USE 4-1-2011; IN COMMERCE 4-1-2011.
MARLENE BELL, EXAMINING ATTORNEY

SN 85-466,745. ALBAUGH, INC., ANKENY, IA. FILED 11-8-2011.

CAP-STAR

THE MARK CONSISTS OF STANDARD CHARACTERS WITHOUT CLAIM TO ANY PARTICULAR FONT, STYLE, SIZE, OR COLOR.

FOR FUNGICIDE FOR TURF AND ORNAMENTAL USE; FUNGICIDES FOR AGRICULTURAL USE; FUNGICIDES FOR DOMESTIC USE (U.S. CLS. 6, 18, 44, 46, 51 AND 52).
GEORGE LORENZO, EXAMINING ATTORNEY

SN 85-470,588. CARDIUM THERAPEUTICS, INC., SAN DIEGO, CA. FILED 11-11-2011.

NEO CHILL

THE MARK CONSISTS OF STANDARD CHARACTERS WITHOUT CLAIM TO ANY PARTICULAR FONT, STYLE, SIZE, OR COLOR.

FOR DIETARY AND NUTRITIONAL SUPPLEMENTS; HERBAL SUPPLEMENTS; PLANT EXTRACTS FOR MEDICAL, VETERINARY AND PHARMACEUTICAL PURPOSES; VITAMIN AND MINERAL PREPARATIONS FOR MEDICAL USE; VITAMIN AND MINERAL SUPPLEMENTS (U.S. CLS. 6, 18, 44, 46, 51 AND 52).
LINDA M. KING, EXAMINING ATTORNEY

SN 85-466,755. ALBAUGH, INC., ANKENY, IA. FILED 11-8-2011.

CAMO

THE MARK CONSISTS OF STANDARD CHARACTERS WITHOUT CLAIM TO ANY PARTICULAR FONT, STYLE, SIZE, OR COLOR.

FOR PESTICIDES (U.S. CLS. 6, 18, 44, 46, 51 AND 52).
GEORGE LORENZO, EXAMINING ATTORNEY

SN 85-471,588. AQUAVIT PHARMACEUTICALS, INC., DBA AQUAVIT PHARMACEUTICALS, INC., NEW YORK, NY. FILED 11-14-2011.

**She is beautiful inside
and out**

THE MARK CONSISTS OF STANDARD CHARACTERS WITHOUT CLAIM TO ANY PARTICULAR FONT, STYLE, SIZE, OR COLOR.

FOR VITAMINS AND VITAMIN PREPARATIONS (U.S. CLS. 6, 18, 44, 46, 51 AND 52).
ANDREW LEASER, EXAMINING ATTORNEY

CLASS 5—(Continued).

SN 85-471,608. AQUAVIT PHARMACEUTICALS, INC., DBA AQUAVIT PHARMACEUTICALS, INC., NEW YORK, NY. FILED 11-14-2011.

Is beauty skin deep?

THE MARK CONSISTS OF STANDARD CHARACTERS WITHOUT CLAIM TO ANY PARTICULAR FONT, STYLE, SIZE, OR COLOR.
FOR VITAMINS AND VITAMIN PREPARATIONS (U.S. CLS. 6, 18, 44, 46, 51 AND 52).
ANDREW LEASER, EXAMINING ATTORNEY

SN 85-471,673. AQUAVIT PHARMACEUTICALS, INC., DBA AQUAVIT PHARMACEUTICALS, INC., NEW YORK, NY. FILED 11-14-2011.

Beauty is not skin deep

THE MARK CONSISTS OF STANDARD CHARACTERS WITHOUT CLAIM TO ANY PARTICULAR FONT, STYLE, SIZE, OR COLOR.
FOR VITAMINS AND VITAMIN PREPARATIONS (U.S. CLS. 6, 18, 44, 46, 51 AND 52).
ANDREW LEASER, EXAMINING ATTORNEY

SN 85-471,764. BIOMARIN PHARMACEUTICAL INC., NOVATO, CA. FILED 11-14-2011.

VIMIZYM

THE MARK CONSISTS OF STANDARD CHARACTERS WITHOUT CLAIM TO ANY PARTICULAR FONT, STYLE, SIZE, OR COLOR.
FOR PHARMACEUTICAL PREPARATIONS FOR THE TREATMENT OF GENETIC DISEASES AND DISORDERS; PHARMACEUTICAL PREPARATIONS FOR USE IN ENZYME THERAPY (U.S. CLS. 6, 18, 44, 46, 51 AND 52).
JENNIFER MARTIN, EXAMINING ATTORNEY

CLASS 5—(Continued).

SN 85-471,893. BIOMARIN PHARMACEUTICAL INC., NOVATO, CA. FILED 11-14-2011.

ZYMOQUIZYME

THE MARK CONSISTS OF STANDARD CHARACTERS WITHOUT CLAIM TO ANY PARTICULAR FONT, STYLE, SIZE, OR COLOR.
FOR PHARMACEUTICAL PREPARATIONS FOR THE TREATMENT OF GENETIC DISEASES AND DISORDERS; PHARMACEUTICAL PREPARATIONS FOR USE IN ENZYME THERAPY (U.S. CLS. 6, 18, 44, 46, 51 AND 52).
JENNIFER MARTIN, EXAMINING ATTORNEY

SN 85-473,001. U.S. PHYTOTHERAPY, INC., ORLANDO, FL. FILED 11-15-2011.

PROACT AB

THE MARK CONSISTS OF THE WORDING "PROACT A-B" IN STYLIZED FONT.
FOR DIETARY AND NUTRITIONAL SUPPLEMENTS CONTAINING ARTEMISININ AND BERBERINE; HERBAL SUPPLEMENTS CONTAINING ARTEMISININ AND BERBERINE (U.S. CLS. 6, 18, 44, 46, 51 AND 52).
FIRST USE 10-31-2011; IN COMMERCE 10-31-2011.
ADA HAN, EXAMINING ATTORNEY

SN 85-478,836. MILLENNIUM PHARMACEUTICALS, INC., CAMBRIDGE, MA. FILED 11-22-2011.

AZUREST

THE MARK CONSISTS OF STANDARD CHARACTERS WITHOUT CLAIM TO ANY PARTICULAR FONT, STYLE, SIZE, OR COLOR.
FOR PHARMACEUTICAL PREPARATIONS FOR THE TREATMENT OF GASTRO-INTESTINAL DISEASES AND DISORDERS, LIVER DISEASES AND DISORDERS, AUTO-IMMUNE DISEASES AND DISORDERS, VIRAL DISEASES AND DISORDERS, AND ORGAN TRANSPLANT REJECTION DISORDERS (U.S. CLS. 6, 18, 44, 46, 51 AND 52).
RICHARD WHITE, EXAMINING ATTORNEY

CLASS 5—(Continued).

SN 85-478,877. MILLENNIUM PHARMACEUTICALS, INC., CAMBRIDGE, MA. FILED 11-22-2011.

TELLANT

THE MARK CONSISTS OF STANDARD CHARACTERS WITHOUT CLAIM TO ANY PARTICULAR FONT, STYLE, SIZE, OR COLOR.

FOR PHARMACEUTICAL PREPARATIONS FOR THE TREATMENT OF GASTRO-INTESTINAL DISEASES AND DISORDERS, LIVER DISEASES AND DISORDERS, AUTO-IMMUNE DISEASES AND DISORDERS, VIRAL DISEASES AND DISORDERS, AND ORGAN TRANSPLANT REJECTION DISORDERS (U.S. CLS. 6, 18, 44, 46, 51 AND 52).

RICHARD WHITE, EXAMINING ATTORNEY

CLASS 5—(Continued).

SN 85-490,209. BAYER AKTIENGESELLSCHAFT, 51373 LEVERKUSEN, FED REP GERMANY, FILED 12-8-2011.

RENAVIA

THE MARK CONSISTS OF STANDARD CHARACTERS WITHOUT CLAIM TO ANY PARTICULAR FONT, STYLE, SIZE, OR COLOR.

OWNER OF U.S. REG. NO. 3,523,567.
FOR VETERINARY PREPARATIONS, NAMELY, ANTIOXIDANTS; VETERINARY PREPARATIONS, NAMELY, MEDICATION FOR RELIEF OF CHRONIC RENAL FAILURE (U.S. CLS. 6, 18, 44, 46, 51 AND 52).

ERIN FALK, EXAMINING ATTORNEY

SN 85-479,168. CONVATEC INC., SKILLMAN, NJ. FILED 11-22-2011.



OWNER OF U.S. REG. NOS. 1,223,890, 1,587,382 AND 2,861,194.

THE MARK CONSISTS OF THE TRADEMARK "DUODERM" IN STYLIZED FONT TOGETHER WITH A WATER DROP DESIGN TO THE LEFT OF THE "DUODERM" TERM AND A STYLIZED WAVE UNDERLINING THE TERM.

FOR MEDICAL DRESSINGS; WOUND DEBRIDEMENT AGENTS; MOISTURIZING GEL AND HYDRO-COLLOID PASTE FOR TREATMENT OF WOUNDS (U.S. CLS. 6, 18, 44, 46, 51 AND 52).

JORDAN BAKER, EXAMINING ATTORNEY

SN 85-492,535. VETS PLUS, INC., KNAPP, WI. FILED 12-12-2011.

PROBIO-VET

THE MARK CONSISTS OF STANDARD CHARACTERS WITHOUT CLAIM TO ANY PARTICULAR FONT, STYLE, SIZE, OR COLOR.

OWNER OF U.S. REG. NOS. 4,091,753 AND 4,091,754.
FOR PROBIOTIC BASED NUTRITIONAL AND DIETARY HEALTH SUPPLEMENTS FOR ANIMALS (U.S. CLS. 6, 18, 44, 46, 51 AND 52).

LUCY ARANT, EXAMINING ATTORNEY

SN 85-482,878. NUTRANOMICS, INC., DBA NUTRANOMICS, DRAPER, UT. FILED 11-29-2011.

LIVE LONGER, LIVE BETTER

THE MARK CONSISTS OF STANDARD CHARACTERS WITHOUT CLAIM TO ANY PARTICULAR FONT, STYLE, SIZE, OR COLOR.

FOR NUTRITIONAL SUPPLEMENTS (U.S. CLS. 6, 18, 44, 46, 51 AND 52).

JEFFREY LOOK, EXAMINING ATTORNEY

SN 85-495,805. KIMBERLY-CLARK WORLDWIDE, INC., NEENAH, WI. FILED 12-15-2011.

SCOTT

THE MARK CONSISTS OF STANDARD CHARACTERS WITHOUT CLAIM TO ANY PARTICULAR FONT, STYLE, SIZE, OR COLOR.

OWNER OF U.S. REG. NOS. 669,919, 2,993,318 AND OTHERS.
FOR AIR FRESHENERS (U.S. CLS. 6, 18, 44, 46, 51 AND 52).

FIRST USE 9-2-2010; IN COMMERCE 9-2-2010.
TASNEEM HUSSAIN, EXAMINING ATTORNEY

CLASS 5—(Continued).

SN 85-499,620. KIMBERLY-CLARK WORLDWIDE, INC., NEENAH, WI. FILED 12-20-2011.

CLASS 5—(Continued).

SN 85-514,973. HEMOSTASIS, LLC, ST. PAUL, MN. FILED 1-12-2012.

SAFESKIN

THE MARK CONSISTS OF STANDARD CHARACTERS WITHOUT CLAIM TO ANY PARTICULAR FONT, STYLE, SIZE, OR COLOR.

OWNER OF U.S. REG. NOS. 1,507,969, 1,921,725 AND 2,033,585.

FOR TOPICAL FIRST AID PREPARATIONS (U.S. CLS. 6, 18, 44, 46, 51 AND 52).

TASNEEM HUSSAIN, EXAMINING ATTORNEY

HEMABOND

THE MARK CONSISTS OF STANDARD CHARACTERS WITHOUT CLAIM TO ANY PARTICULAR FONT, STYLE, SIZE, OR COLOR.

FOR WOUND DRESSINGS INCLUDING A HEMOSTAT SEALANT (U.S. CLS. 6, 18, 44, 46, 51 AND 52).

JENNY PARK, EXAMINING ATTORNEY

SN 85-511,160. ARLEN, MICHAEL W, LOS ANGELES, CA. FILED 1-7-2012.

EAT TO YOUR HEART'S CONTENT

THE MARK CONSISTS OF STANDARD CHARACTERS WITHOUT CLAIM TO ANY PARTICULAR FONT, STYLE, SIZE, OR COLOR.

FOR POWDERED NUTRITIONAL SUPPLEMENT MIX FOR A SOFT-SERVE DESSERT (U.S. CLS. 6, 18, 44, 46, 51 AND 52).

FIRST USE 11-2-2011; IN COMMERCE 11-2-2011. TASNEEM HUSSAIN, EXAMINING ATTORNEY

CLASS 6—METAL GOODS

SN 76-707,970. ADVANCED SEALING & SUPPLY CO., INC., CERRITOS, CA. FILED 6-13-2011.

SN 85-511,162. ARLEN, MICHAEL W, LOS ANGELES, CA. FILED 1-7-2012.

ALKY - ONE

NEWTRITIOUS IS DELICIOUS!

THE MARK CONSISTS OF STANDARD CHARACTERS WITHOUT CLAIM TO ANY PARTICULAR FONT, STYLE, SIZE, OR COLOR.

FOR POWDERED NUTRITIONAL SUPPLEMENT MIX FOR A SOFT-SERVE DESSERT (U.S. CLS. 6, 18, 44, 46, 51 AND 52).

FIRST USE 11-2-2011; IN COMMERCE 11-2-2011. TASNEEM HUSSAIN, EXAMINING ATTORNEY

FOR GASKETS, NAMELY, METAL GASKETS FOR SEALING GAS AND LIQUID BETWEEN TWO SURFACES FOR USE IN THE PETROLEUM, CHEMICAL, NUCLEAR, AND POWER INDUSTRIES (U.S. CLS. 2, 12, 13, 14, 23, 25 AND 50).

FIRST USE 4-26-2011; IN COMMERCE 4-26-2011. SKYE YOUNG, EXAMINING ATTORNEY

CLASS 6—(Continued).

SN 79-098,471. JIANGSU XINGLONG METAL PRODUCTS CO., LTD., CHINA, FILED 5-27-2011.



OWNER OF INTERNATIONAL REGISTRATION 1080173 DATED 5-27-2011, EXPIRES 5-27-2021.

THE MARK CONSISTS OF HALF A CIRCLE WITH A RIGHT ANGLE INSIDE CONTAINING A PATTERN OF CIRCLES, AND POLYGONS WITH A LINE THROUGH THE CENTER; BENEATH THE HALF CIRCLE IS A RECTANGULAR SHAPE CONTAINING BARS, BANDS AND TWO CHINESE CHARACTERS.

THE NON-LATIN CHARACTERS IN THE MARK TRANSLITERATE TO "XING LONG" AND THIS MEANS "PROSPEROUS DRAGON" IN ENGLISH.

FOR STEEL WIRE; WIRE ROPE; WIRE GAUZE (U.S. CLS. 2, 12, 13, 14, 23, 25 AND 50).

TRICIA SONNEBORN, EXAMINING ATTORNEY

SN 85-096,525. MIDDLE KINGDOM MINIATURES, ROEBUCK, SC. FILED 7-30-2010.



NO CLAIM IS MADE TO THE EXCLUSIVE RIGHT TO USE "MARTIAL" AND "COLLECTION", APART FROM THE MARK AS SHOWN.

THE MARK CONSISTS OF A VERTICAL SHADED OVAL CONTAINING UNSHADED CHINESE CHARACTERS, WHICH TRANSLITERATE TO WU DE PINYIN, WHICH TRANSLATES IN ENGLISH TO "MARTIAL VIRTUE", WITH AN UN-SHADED PARTIAL SHADOW OF THE OVAL TO THE RIGHT, WITH THE WORDING, "MARTIAL VIRTUE COLLECTION" TO THE RIGHT OF THE SHADED OVAL.

THE ENGLISH TRANSLATION OF THE CHINESE CHARACTERS IN THE MARK IS "MARTIAL VIRTUE".

THE NON-LATIN CHARACTERS IN THE MARK TRANSLITERATE TO WU DE PINYIN, AND THIS MEANS "MARTIAL VIRTUE" IN ENGLISH.

FOR METAL FIGURINES, NAMELY, MINIATURE COLLECTIBLE FIGURINES (U.S. CLS. 2, 12, 13, 14, 23, 25 AND 50).

ODESSA BIBBINS, EXAMINING ATTORNEY

CLASS 6—(Continued).

SN 85-163,789. SMALLEY STEEL RING COMPANY, LAKE ZURICH, IL. FILED 10-28-2010.

SMALLEY

THE MARK CONSISTS OF STANDARD CHARACTERS WITHOUT CLAIM TO ANY PARTICULAR FONT, STYLE, SIZE, OR COLOR.

OWNER OF U.S. REG. NO. 1,502,816.

SEC. 2(F).

FOR METAL RETAINING RINGS, METAL WAVE SPRINGS, METAL SEALING RINGS, AND METAL HARDWARE, NAMELY, EXPANDERS (U.S. CLS. 2, 12, 13, 14, 23, 25 AND 50).

FIRST USE 1-1-1918; IN COMMERCE 1-1-1918.

JOHN DWYER, EXAMINING ATTORNEY

SN 85-179,581. STINSON, DENNIS DEAN, TA STINSON AEROSPACE, THRESHFIELD, BD23 5ER, UNITED KINGDOM, FILED 11-18-2010.

SA

THE MARK CONSISTS OF STANDARD CHARACTERS WITHOUT CLAIM TO ANY PARTICULAR FONT, STYLE, SIZE, OR COLOR.

OWNER OF UNITED KINGDOM REG. NO. 2574122, DATED 3-3-2011, EXPIRES 3-3-2021.

THE WORDING "SA" HAS NO MEANING IN A FOREIGN LANGUAGE.

FOR BOLTS, NUTS, WASHERS, FASTENERS, OF METAL (U.S. CLS. 2, 12, 13, 14, 23, 25 AND 50).

THOMAS MANOR, EXAMINING ATTORNEY

SN 85-281,371. LAMIN-ART, INC., SCHAUMBURG, IL. FILED 3-30-2011.

METAL-ART

THE MARK CONSISTS OF STANDARD CHARACTERS WITHOUT CLAIM TO ANY PARTICULAR FONT, STYLE, SIZE, OR COLOR.

FOR METAL LAMINATE SHEETS USED IN A DECORATIVE SURFACE FINISH FOR COVERING FURNITURE, CABINETRY, FIXTURES, AND OTHER CASE GOODS, AND FOR VERTICAL AND HORIZONTAL INTERIOR ARCHITECTURAL APPLICATIONS, NAMELY, WALLS, CEILINGS, WORK SURFACES, AND OTHER FLAT AND CURVED SURFACES (U.S. CLS. 2, 12, 13, 14, 23, 25 AND 50).

TRACY CROSS, EXAMINING ATTORNEY

CLASS 6—(Continued).

SN 85-321,764. KULKONI, INC., HOUSTON, TX. FILED 5-16-2011.

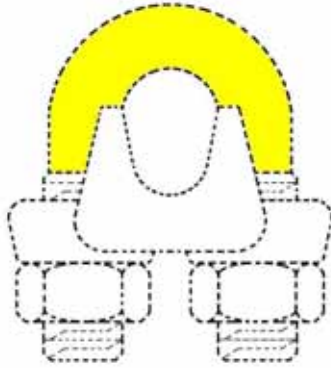

OWNER OF U.S. REG. NO. 2,011,393.
 THE COLOR(S) YELLOW IS/ARE CLAIMED AS A FEATURE OF THE MARK.
 THE MARK CONSISTS OF THE COLOR YELLOW APPLIED TO THE SMOOTH U-BOLT SEGMENT OF A DROP FORGED WIRE ROPE CLIP. THE MARK SHOWN IN BROKEN OR DOTTED LINES, NAMELY, THE CONFIGURATION OF THE GOODS INCLUDING THE "U" SHAPE OF THE BOLT, IS NOT CLAIMED AS PART OF THE MARK AND SERVES ONLY TO SHOW THE POSITION OR PLACEMENT OF THE MARK. THE MARK APPEARS ON A TRANSPARENT BACKGROUND.
 SEC. 2(F).
 FOR WIRE ROPE FITTINGS OF METAL, NAMELY, DROP FORGED WIRE ROPE CLIPS (U.S. CLS. 2, 12, 13, 14, 23, 25 AND 50).
 FIRST USE 3-31-2006; IN COMMERCE 3-31-2006.
 LINDA ESTRADA, EXAMINING ATTORNEY

SN 85-334,020. BECKM, LLC, GUILFORD, CT. FILED 5-31-2011.

TELEFLIGHT

THE MARK CONSISTS OF STANDARD CHARACTERS WITHOUT CLAIM TO ANY PARTICULAR FONT, STYLE, SIZE, OR COLOR.
 FOR METAL STAIRCASES AND METAL STRUCTURAL COMPONENTS THEREOF, NAMELY, STAIRS, TREADS, STRINGERS, BALUSTERS, AND RAILINGS (U.S. CLS. 2, 12, 13, 14, 23, 25 AND 50).
 STEVEN PEREZ, EXAMINING ATTORNEY

CLASS 6—(Continued).

SN 85-383,251. C & N FOUNDATION TECHNOLOGIES, INC., SAN ANTONIO, FL. FILED 7-28-2011.



NO CLAIM IS MADE TO THE EXCLUSIVE RIGHT TO USE "FOUNDATION SYSTEMS", APART FROM THE MARK AS SHOWN.
 THE MARK CONSISTS OF A MINUTEMAN HOLDING A HELICAL PIER AND STANDING IN FRONT OF A STYLIZED VERSION OF THE FLAG OF THE UNITED STATES OF AMERICA. THE MINUTEMAN AND AMERICAN FLAG APPEAR WITHIN TWO CIRCLES AND WITHIN THE CIRCLES THE WORDING "PATRIOT FOUNDATION SYSTEMS" APPEARS. THE WORDING "BRACING FOR TOMORROW!" APPEARS BENEATH THE CIRCLES.
 FOR CONSTRUCTION ELEMENTS MADE OF METAL, NAMELY, BRACING, TIEBACKS, HELICAL PIERS, PILES FOR BUILDING FOUNDATIONS (U.S. CLS. 2, 12, 13, 14, 23, 25 AND 50).
 LINDA ESTRADA, EXAMINING ATTORNEY

SN 85-416,571. ARMOR CONCEPTS LLC, NASHVILLE, TN. FILED 9-7-2011.

Door Jamb Armor

THE MARK CONSISTS OF STANDARD CHARACTERS WITHOUT CLAIM TO ANY PARTICULAR FONT, STYLE, SIZE, OR COLOR.
 OWNER OF U.S. REG. NO. 3,113,283.
 NO CLAIM IS MADE TO THE EXCLUSIVE RIGHT TO USE "DOOR JAMB", APART FROM THE MARK AS SHOWN.
 SEC. 2(F).
 FOR DOOR CASINGS OF METAL; DOOR FRAMES OF METAL; DOOR JAMBS OF METAL (U.S. CLS. 2, 12, 13, 14, 23, 25 AND 50).
 FIRST USE 5-10-2005; IN COMMERCE 5-10-2005.
 REGINA DRUMMOND, EXAMINING ATTORNEY

CLASS 6—(Continued).

SN 85-417,580. CALDWELL MANUFACTURING COMPANY, ROCHESTER, NY. FILED 9-8-2011.

ROLLER TILT CARTRIDGE

THE MARK CONSISTS OF STANDARD CHARACTERS WITHOUT CLAIM TO ANY PARTICULAR FONT, STYLE, SIZE, OR COLOR.

OWNER OF U.S. REG. NO. 1,969,915.

NO CLAIM IS MADE TO THE EXCLUSIVE RIGHT TO USE "CARTRIDGE", APART FROM THE MARK AS SHOWN.

FOR METAL SPRING COUNTERBALANCES FOR VERTICALLY MOVABLE WINDOW SASH AND MOUNTING BRACKETS SOLD TOGETHER AS A UNIT (U.S. CLS. 2, 12, 13, 14, 23, 25 AND 50).

FIRST USE 4-0-2010; IN COMMERCE 4-0-2010.
RAMONA ORTIGA, EXAMINING ATTORNEY

CLASS 6—(Continued).

SN 85-443,695. STI/SPFA, LAKE ZURICH, IL. FILED 10-10-2011.

CleanSite Containment

THE MARK CONSISTS OF STANDARD CHARACTERS WITHOUT CLAIM TO ANY PARTICULAR FONT, STYLE, SIZE, OR COLOR.

NO CLAIM IS MADE TO THE EXCLUSIVE RIGHT TO USE "CONTAINMENT", APART FROM THE MARK AS SHOWN.

FOR STEEL STORAGE TANKS, NAMELY, A TANK TO CAPTURE AND HOLD WASTE MATERIAL FROM LIQUID THAT IS PUMPED INTO WELLS TO FORCE OUT OIL (U.S. CLS. 2, 12, 13, 14, 23, 25 AND 50).

JULIE VEPPUMTHARA, EXAMINING ATTORNEY

SN 85-430,996. SOARES, ANDREW, OAKDALE, CA. FILED 9-23-2011.

Adapt-o-pole Pool Pole Adapter

THE MARK CONSISTS OF STANDARD CHARACTERS WITHOUT CLAIM TO ANY PARTICULAR FONT, STYLE, SIZE, OR COLOR.

NO CLAIM IS MADE TO THE EXCLUSIVE RIGHT TO USE "POOL POLE ADAPTER", APART FROM THE MARK AS SHOWN.

FOR FITTED TOOL ADAPTERS FOR USE WITH ALUMINUM SWIMMING POOL SKIMMER HANDLES FOR ALLOWING THE COMBINED USE OF THE POLE WITH OTHER HOUSEHOLD CLEANING TOOLS (U.S. CLS. 2, 12, 13, 14, 23, 25 AND 50).

FIRST USE 5-1-2006; IN COMMERCE 3-23-2011.
AMY KELLY, EXAMINING ATTORNEY

SN 85-446,567. KINGSPAN HOLDINGS (IRL) LIMITED, CO CAVAN, IRELAND, FILED 10-13-2011.

RACKAIRE

THE MARK CONSISTS OF STANDARD CHARACTERS WITHOUT CLAIM TO ANY PARTICULAR FONT, STYLE, SIZE, OR COLOR.

FOR METAL ACCESS FLOOR PANELS (U.S. CLS. 2, 12, 13, 14, 23, 25 AND 50).

ELLEN B. AWRICH, EXAMINING ATTORNEY

SN 85-433,724. CHART INC., GARFIELD HEIGHTS, OH. FILED 9-28-2011.

ChillZilla

THE MARK CONSISTS OF STANDARD CHARACTERS WITHOUT CLAIM TO ANY PARTICULAR FONT, STYLE, SIZE, OR COLOR.

FOR METAL CRYOGENIC BULK STORAGE TANKS (U.S. CLS. 2, 12, 13, 14, 23, 25 AND 50).

FIRST USE 1-31-2011; IN COMMERCE 1-31-2011.
JEFFREY LOOK, EXAMINING ATTORNEY

SN 85-446,988. BW GLOBAL STRUCTURES INC., ALDER-GROVE, BC, CANADA, FILED 10-13-2011.

GUARDIAN SHELTERS

THE MARK CONSISTS OF STANDARD CHARACTERS WITHOUT CLAIM TO ANY PARTICULAR FONT, STYLE, SIZE, OR COLOR.

OWNER OF CANADA REG. NO. TMA807,903, DATED 9-28-2011, EXPIRES 9-28-2026.

NO CLAIM IS MADE TO THE EXCLUSIVE RIGHT TO USE "SHELTERS", APART FROM THE MARK AS SHOWN.

FOR PREFABRICATED BUILDINGS CONSISTING PRIMARILY OF METAL FRAMES AND TARPAULIN COVERS AND STRUCTURAL PARTS THEREFOR USED FOR INDUSTRIAL, COMMERCIAL AND RESIDENTIAL PURPOSES (U.S. CLS. 2, 12, 13, 14, 23, 25 AND 50).

MEGHAN REINHART, EXAMINING ATTORNEY

CLASS 6—(Continued).

SN 85-449,054. GRIPPLE LIMITED, SHEFFIELD, GREAT BRITAIN, FILED 10-17-2011.

TERRA-LOCK

THE MARK CONSISTS OF STANDARD CHARACTERS WITHOUT CLAIM TO ANY PARTICULAR FONT, STYLE, SIZE, OR COLOR.
FOR ANCHORS (U.S. CLS. 2, 12, 13, 14, 23, 25 AND 50).
SUNG IN, EXAMINING ATTORNEY

SN 85-449,265. SIMPSON STRONG-TIE COMPANY, INC., PLEASANTON, CA. FILED 10-17-2011.

DEXXTER

THE MARK CONSISTS OF STANDARD CHARACTERS WITHOUT CLAIM TO ANY PARTICULAR FONT, STYLE, SIZE, OR COLOR.
FOR METAL SCREWS (U.S. CLS. 2, 12, 13, 14, 23, 25 AND 50).
FIRST USE 5-31-2005; IN COMMERCE 5-31-2005.
SUSAN STIGLITZ, EXAMINING ATTORNEY

SN 85-450,011. QUALITY EDGE, INC., WALKER, MI. FILED 10-18-2011.

TRULEGACY

THE MARK CONSISTS OF STANDARD CHARACTERS WITHOUT CLAIM TO ANY PARTICULAR FONT, STYLE, SIZE, OR COLOR.
FOR METAL FASCIA ASSEMBLY FOR BUILDINGS (U.S. CLS. 2, 12, 13, 14, 23, 25 AND 50).
ALLISON HOLTZ, EXAMINING ATTORNEY

CLASS 6—(Continued).

SN 85-450,036. RAVENSFORGE CONEG LLC, SEATTLE, WA. FILED 10-18-2011.

SKATEBLOCK

THE MARK CONSISTS OF STANDARD CHARACTERS WITHOUT CLAIM TO ANY PARTICULAR FONT, STYLE, SIZE, OR COLOR.
FOR METAL BRACKETS USED TO PROTECT EDGES OF STRUCTURES BY PREVENTING SKATEBOARDERS AND SKATERS FROM SLIDING ALONG THE EDGES OF STRUCTURES (U.S. CLS. 2, 12, 13, 14, 23, 25 AND 50).
FIRST USE 5-7-1998; IN COMMERCE 6-17-1998.
JESSICA A. POWERS, EXAMINING ATTORNEY

SN 85-451,701. QUALITY EDGE, INC., WALKER, MI. FILED 10-20-2011.

TRUPLANK

THE MARK CONSISTS OF STANDARD CHARACTERS WITHOUT CLAIM TO ANY PARTICULAR FONT, STYLE, SIZE, OR COLOR.
FOR METAL FASCIA ASSEMBLY FOR BUILDINGS (U.S. CLS. 2, 12, 13, 14, 23, 25 AND 50).
ALLISON HOLTZ, EXAMINING ATTORNEY

SN 85-452,182. PRIME-LINE PRODUCTS COMPANY, REDLANDS, CA. FILED 10-20-2011.

PRECISION SCREEN PRODUCTS

THE MARK CONSISTS OF STANDARD CHARACTERS WITHOUT CLAIM TO ANY PARTICULAR FONT, STYLE, SIZE, OR COLOR.
NO CLAIM IS MADE TO THE EXCLUSIVE RIGHT TO USE "SCREEN PRODUCTS", APART FROM THE MARK AS SHOWN.
FOR SCREEN ASSEMBLIES MADE PRIMARILY OF METAL FOR COVERING WINDOWS AND DOORS (U.S. CLS. 2, 12, 13, 14, 23, 25 AND 50).
BERNICE MIDDLETON, EXAMINING ATTORNEY

CLASS 6—(Continued).

SN 85-472,513. QUALITY EDGE, INC., WALKER, MI. FILED 11-15-2011.

GUTTER GEKKO

THE MARK CONSISTS OF STANDARD CHARACTERS WITHOUT CLAIM TO ANY PARTICULAR FONT, STYLE, SIZE, OR COLOR.

NO CLAIM IS MADE TO THE EXCLUSIVE RIGHT TO USE "GUTTER", APART FROM THE MARK AS SHOWN.

FOR METAL DEBRIS GUARDS FOR GUTTERS (U.S. CLS. 2, 12, 13, 14, 23, 25 AND 50).

ALLISON HOLTZ, EXAMINING ATTORNEY

SN 85-477,442. QUALITY EDGE, INC., WALKER, MI. FILED 11-21-2011.

TRUCOIL

THE MARK CONSISTS OF STANDARD CHARACTERS WITHOUT CLAIM TO ANY PARTICULAR FONT, STYLE, SIZE, OR COLOR.

FOR METAL TRIM FOR BUILDINGS (U.S. CLS. 2, 12, 13, 14, 23, 25 AND 50).

ALLISON HOLTZ, EXAMINING ATTORNEY

SN 85-478,917. HOPE PAIGE DESIGNS, LLC, WEST CON-SHOHOCKEN, PA. FILED 11-22-2011.

TEXTID TOPPER

THE MARK CONSISTS OF STANDARD CHARACTERS WITHOUT CLAIM TO ANY PARTICULAR FONT, STYLE, SIZE, OR COLOR.

OWNER OF U.S. REG. NO. 3,610,625.

FOR METAL INFORMATION BEARING PLATES FOR USE WITH FLEXIBLE WRIST BANDS (U.S. CLS. 2, 12, 13, 14, 23, 25 AND 50).

FIRST USE 11-1-2011; IN COMMERCE 11-1-2011.

JASON TURNER, EXAMINING ATTORNEY

CLASS 7—MACHINERY

SN 76-704,634. HENNESSY INDUSTRIES, INC., LAVERGNE, TN. FILED 9-23-2010.

X-MODEL

THE MARK CONSISTS OF STANDARD CHARACTERS WITHOUT CLAIM TO ANY PARTICULAR FONT, STYLE, SIZE, OR COLOR.

FOR TIRE CHANGING MACHINES FOR LOOSENING OF TIRE BEADS AND DEMOUNTING AND MOUNTING OF A TIRE FROM A WHEEL RIM (U.S. CLS. 13, 19, 21, 23, 31, 34 AND 35).

TINA MAI, EXAMINING ATTORNEY

SN 76-704,635. HENNESSY INDUSTRIES, INC., LAVERGNE, TN. FILED 9-23-2010.

X-SERIES

THE MARK CONSISTS OF STANDARD CHARACTERS WITHOUT CLAIM TO ANY PARTICULAR FONT, STYLE, SIZE, OR COLOR.

FOR TIRE CHANGING MACHINES FOR LOOSENING OF TIRE BEADS AND DEMOUNTING AND MOUNTING OF A TIRE FROM A WHEEL RIM (U.S. CLS. 13, 19, 21, 23, 31, 34 AND 35).

TINA MAI, EXAMINING ATTORNEY

CLASS 7—(Continued).

SN 77-855,025. RAISMAN CORPORATION, MIAMI, FL.
FILED 10-22-2009.

CLASS 7—(Continued).

SN 79-099,036. MELETT LTD, UNITED KINGDOM, FILED 5-18-2011.

RAISMAN

MELETT

THE MARK CONSISTS OF STANDARD CHARACTERS WITHOUT CLAIM TO ANY PARTICULAR FONT, STYLE, SIZE, OR COLOR.

SEC. 2(F).

FOR CARBURETORS; CARBURETOR KITS COMPRISED OF PARTS OF CARBURETORS, NAMELY, GASKETS, DIAPHRAGMS, NEEDLES, SEATS, THROTTLE LEVERS, VALVES; CARBURETOR PARTS, NAMELY, CHOKE LEVERS, NOZZLES, JETS AND FLOAT SEATS; SPINDLE ASSEMBLIES FOR MOTOR VEHICLE MOTORS; SPINDLE PARTS FOR MOTOR VEHICLE MOTORS, NAMELY, SPINDLE SHAFTS, SPINDLE BEARINGS AND PULLEY SPLITS FOR SPINDLES; LAWN MOWER PARTS, NAMELY, TRIMMER HEADS, PRIMER BULBS, OIL PUMPS, CLUTCH SPRINGS, EXHAUST PIPES, THROTTLE CABLES AND CONTROL CABLES; CLUTCH SHOES FOR LAWN MOWERS AND POWER-OPERATED BRUSH CUTTERS; STRUCTURAL PARTS OF CHAIN SAWS, NAMELY, FUEL TANKS; AIR FILTERS FOR MOTORS AND ENGINES; COVERS FOR AIR FILTERS FOR MOTORS AND ENGINES; IGNITION COILS BEING PARTS OF INTERNAL COMBUSTION ENGINES; STARTER SOLENOIDS BEING PARTS OF INTERNAL COMBUSTION ENGINES; INTAKE VALVES FOR INTERNAL COMBUSTION ENGINES; EXHAUST VALVES FOR INTERNAL COMBUSTION ENGINES; PARTS FOR CHAIN SAWS AND POWER-OPERATED BRUSH CUTTERS, NAMELY, FUEL TUBES, FUEL TUBE INTAKES, GEARS, SHOCK ABSORBERS; SPARK PLUGS; MACHINE PARTS, NAMELY, BLADES, CYLINDERS, BELTS AND CRANK SHAFTS; ENGINE PARTS, NAMELY, PISTONS, PISTON RINGS, CONTACT POINTS AND ADAPTORS; MOTOR AND ENGINE PARTS, NAMELY, STARTER GRIPS, STARTER PULLEYS, STARTER SPRINGS, STARTER PAWLS, STARTER RINGS, STARTER COVERS, MUFFLERS; CONNECTING RODS FOR MACHINES, MOTORS AND ENGINES; COVERS FOR CHAIN SAW FUEL TANKS; FUEL FILTERS (U.S. CLS. 13, 19, 21, 23, 31, 34 AND 35).

FIRST USE 1-0-2007; IN COMMERCE 1-0-2007.

ROBERT C. CLARK JR., EXAMINING ATTORNEY

THE MARK CONSISTS OF STANDARD CHARACTERS WITHOUT CLAIM TO ANY PARTICULAR FONT, STYLE, SIZE, OR COLOR.

OWNER OF INTERNATIONAL REGISTRATION 1081741 DATED 5-18-2011, EXPIRES 5-18-2021.

THE NAME "MELETT" DOES NOT IDENTIFY A LIVING INDIVIDUAL.

THE WORDING "MELETT" HAS NO MEANING IN A FOREIGN LANGUAGE.

FOR AUTOMOTIVE PARTS, NAMELY, TURBOCHARGERS; TURBOCHARGERS FOR MACHINES; IMPELLERS FOR TURBO-SUPERCHARGERS FOR MACHINES; SUPERCHARGERS BEING TYPES OF TURBOCHARGERS FOR MACHINES; TURBO-SUPERCHARGERS FOR ENGINES; TURBOSUPERCHARGERS FOR LAND VEHICLE ENGINES; TURBOSUPERCHARGERS FOR VEHICLE ENGINES; AIR COMPRESSORS FOR VEHICLES; PUMPS AND COMPRESSORS AS PARTS OF MACHINES, MOTORS AND ENGINES; COMPRESSORS FOR SUPERCHARGING INTERNAL COMBUSTION ENGINES; COMPRESSORS AS PARTS OF MACHINES, MOTORS AND ENGINES; TURBOCOMPRESSORS BEING PARTS OF MACHINES; ROTARY AIR COMPRESSORS; MECHANICALLY DRIVEN AIR CHARGE COMPRESSORS FOR INTERNAL COMBUSTION ENGINES; COMPRESSORS FOR MACHINES (U.S. CLS. 13, 19, 21, 23, 31, 34 AND 35).

MELISSA VALLILLO, EXAMINING ATTORNEY

CLASS 7—(Continued).

SN 79-100,570. ÖZÇELİK MAKİNA SANAYİ VE TİCARET LİMİTED SİRKETİ, TURKEY, FILED 6-28-2010.



OWNER OF INTERNATIONAL REGISTRATION 0881696 DATED 12-30-2005, EXPIRES 12-30-2015.

THE COLOR(S) BLACK, BLUE, RED AND WHITE IS/ARE CLAIMED AS A FEATURE OF THE MARK.

THE MARK CONSISTS OF THE WORD "ÖZÇELİK" IN BLACK, BENEATH A BLUE RECTANGLE IN WHICH IS A RED SQUARE OVER A RED POLYGON IN WHICH IS A WHITE CIRCLE OUTLINE WITH A RED CENTER.

THE WORDING "ÖZÇELİK" HAS NO MEANING IN A FOREIGN LANGUAGE.

FOR MACHINES AND PARTS FOR MACHINES FOR PROCESSING WOOD, METAL, STONE AND PLASTIC MATERIALS, NAMELY, BENDING MACHINES, BROACHING MACHINES, BORING MACHINES, CUTTING MACHINES, HORNING MACHINES, LAPPING MACHINES, GRINDING MACHINES, MILLING MACHINES, PLANING MACHINES, WELDING MACHINES, SHAPING MACHINES, SHEARING MACHINES, SLOTTING MACHINES, PERFORATING MACHINES FOR METALWORKING; SANDING MACHINES FOR WOODWORKING; BEATING MACHINES, CHIPPING MACHINES, DRILLING MACHINES, SAWING MACHINES FOR WOODWORKING; MACHINES AND MACHINE TOOLS FOR THE CUTTING AND FORMING OF MATERIALS, NAMELY, PRESS DIES FOR METAL FORMING, RUBBER FORMING MACHINES, HARD METAL TOOLS, CARBIDE TOOLS, CERAMIC TOOLS, DIAMOND-COATED AND DIAMOND-UNCOATED TOOLS FOR THE CUTTING AND FORMING OF MATERIALS; MACHINES FOR PLASTICS WORKING, NAMELY, INJECTION PLASTIC MOLDING MACHINES, COMPRESSION MOLDING MACHINES, EXTRUSION MOLDING MACHINES, INJECTION MOLDING MACHINES, CASTING MACHINES; MACHINES PARTS, NAMELY, MILL-STONES AND GRINDSTONES (U.S. CLS. 13, 19, 21, 23, 31, 34 AND 35).

FRED CARL, EXAMINING ATTORNEY

SN 79-106,213. SHIMADZU CORPORATION, JAPAN, FILED 10-21-2011.

PRIORITY DATE OF 8-4-2011 IS CLAIMED.

OWNER OF INTERNATIONAL REGISTRATION 1099418 DATED 10-21-2011, EXPIRES 10-21-2021.

FOR SOLAR CELL ANTI-REFLECTION COATING MACHINES; CVD MACHINES; THIN FILM MANUFACTURING MACHINES; SEMICONDUCTOR MANUFACTURING MACHINES (U.S. CLS. 13, 19, 21, 23, 31, 34 AND 35).

THOMAS MANOR, EXAMINING ATTORNEY

CLASS 7—(Continued).

SN 79-106,214. SHIMADZU CORPORATION, JAPAN, FILED 10-21-2011.

PRIORITY DATE OF 8-4-2011 IS CLAIMED.

OWNER OF INTERNATIONAL REGISTRATION 1099419 DATED 10-21-2011, EXPIRES 10-21-2021.

FOR SOLAR CELL ANTI-REFLECTION COATING MACHINES; CVD MACHINES; THIN FILM MANUFACTURING MACHINES; SEMICONDUCTOR MANUFACTURING MACHINES (U.S. CLS. 13, 19, 21, 23, 31, 34 AND 35).

THOMAS MANOR, EXAMINING ATTORNEY

SN 85-086,719. SVENSKA INDUSTRIBORSTAR I VASTERAS AB, VASTERAS, SWEDEN, FILED 7-16-2010.

THE MARK CONSISTS OF STANDARD CHARACTERS WITHOUT CLAIM TO ANY PARTICULAR FONT, STYLE, SIZE, OR COLOR.

PRIORITY CLAIMED UNDER SEC. 44(D) ON ERPN CMNTY TM OFC APPLICATION NO. 008816233, FILED 1-18-2010, REG. NO. 008816233, DATED 8-24-2010, EXPIRES 1-18-2020.

FOR MACHINES AND MACHINE TOOLS, NAMELY, INDUSTRIAL BRUSH PARTS OF OR FOR USE WITH MAINTENANCE AND CLEANING MACHINES FOR CLEANING AIRPORT RUNWAYS; MACHINE COUPLING AND TRANSMISSION COMPONENTS EXCEPT FOR LAND VEHICLES; MECHANICAL BRUSH PARTS OF MACHINES, NAMELY, BRUSHES BEING PARTS OF MACHINES FOR SEALING, SCORING, DEBURRING, SMOOTHING, CLEANING AND GRINDING AIRPORT RUNWAYS; PARTS OF MACHINES, NAMELY, JOURNAL BOXES AND AXLES FOR MACHINES THAT TREAT AIRPORT RUNWAY SURFACES (U.S. CLS. 13, 19, 21, 23, 31, 34 AND 35).

ESTHER BELENKER, EXAMINING ATTORNEY

SN 85-264,128. PROSSER, JAMES E., SPRING CITY, PA, FILED 3-11-2011.

THE MARK CONSISTS OF STANDARD CHARACTERS WITHOUT CLAIM TO ANY PARTICULAR FONT, STYLE, SIZE, OR COLOR.

FOR CRANES; TRUCK CRANES (U.S. CLS. 13, 19, 21, 23, 31, 34 AND 35).

KELLY TRUSILO, EXAMINING ATTORNEY

CLASS 7—(Continued).

SN 85-265,349. PROSSER, JAMES E., SPRING CITY, PA. FILED 3-12-2011.



NO CLAIM IS MADE TO THE EXCLUSIVE RIGHT TO USE "LADDER RACK", APART FROM THE MARK AS SHOWN.

THE MARK CONSISTS OF THE TERM "LOADERACK" WHEREIN THE "K" COMPRISES A CRANE BOOM, WHICH IS LIFTING THE SECOND "A" COMPRISING THE "LOADERACK" TERM; AND A "THE LADDER RACK THAT SAVES YOUR BACK" PHRASE IS LOCATED BELOW THE "LOADERACK" TERM.

FOR CRANES; TRUCK CRANES (U.S. CLS. 13, 19, 21, 23, 31, 34 AND 35).

KELLY TRUSILO, EXAMINING ATTORNEY

CLASS 7—(Continued).

SN 85-332,511. GREENFIELD WORLD TRADE, INC., FORT LAUDERDALE, FL. FILED 5-27-2011.



THE MARK CONSISTS OF A STYLIZED LETTER "B". FOR WASHING MACHINES, NAMELY, DISH-WASHERS, POT AND UTENSIL WASHERS, GLASS WASHERS; ELECTRIC FOOD MIXERS; POWER-OPERATED SILVER AND STAINLESS STEEL BURNISHERS; ELECTRIC PRODUCE PEELERS; ELECTRIC FOOD SLICERS (U.S. CLS. 13, 19, 21, 23, 31, 34 AND 35).

FIRST USE 0-0-1963; IN COMMERCE 0-0-1963. CHRISTINE COOPER, EXAMINING ATTORNEY

SN 85-332,648. ULTRA-AIRE INC., FOX RIVER GROVE, IL. FILED 5-27-2011.



NO CLAIM IS MADE TO THE EXCLUSIVE RIGHT TO USE "ODOR FREE AIR", APART FROM THE MARK AS SHOWN.

THE COLOR(S) BLUE, GREEN AND BLACK IS/ARE CLAIMED AS A FEATURE OF THE MARK.

THE MARK CONSISTS OF THE WORDS "ULTRA-AIRE" IN BLACK SEPARATED BY A BLACK SUN IN FRONT OF A BLUE AND GREEN SUNBURST ORIGINATING IN THE MIDDLE OF THE WORDING AND SHOOTING UPWARD, ALL ABOVE THE WORDING "THE SOLUTION FOR ODOR FREE AIR" IN BLACK.

FOR ELECTRONICALLY-POWERED MISTING MACHINE FOR DISCHARGING ULTRASONICALLY MISTED SOLUTION FOR ENCAPSULATING AIRBORNE, ODIFEROUS COMPOUNDS AND ELIMINATING ODORS (U.S. CLS. 13, 19, 21, 23, 31, 34 AND 35).

MARLENE BELL, EXAMINING ATTORNEY

SN 85-271,507. COMPETITION PRODUCTS, INC., OSHKOSH, WI. FILED 3-19-2011.

Competition Products

THE MARK CONSISTS OF STANDARD CHARACTERS WITHOUT CLAIM TO ANY PARTICULAR FONT, STYLE, SIZE, OR COLOR.

NO CLAIM IS MADE TO THE EXCLUSIVE RIGHT TO USE "PRODUCTS", APART FROM THE MARK AS SHOWN. SEC. 2(F).

FOR HIGH PERFORMANCE AUTOMOBILE AND BOAT ENGINE PARTS, NAMELY, HYDRAULIC VALVE LIFTERS, VALVE TRAIN DRIVES, NAMELY, VALVE AND PUSHRODS, AND CAMSHAFTS, VALVE SEALS, VALVE LOCKS, AND VALVE SPRINGS (U.S. CLS. 13, 19, 21, 23, 31, 34 AND 35).

FIRST USE 12-31-1974; IN COMMERCE 12-31-1984. KATINA MISTER, EXAMINING ATTORNEY

CLASS 7—(Continued).

SN 85-365,005. HUSKIE TOOLS, INC., GLENDALE HEIGHTS, IL. FILED 7-7-2011.

HUSKIE TOOLS

THE MARK CONSISTS OF STANDARD CHARACTERS WITHOUT CLAIM TO ANY PARTICULAR FONT, STYLE, SIZE, OR COLOR.

OWNER OF U.S. REG. NOS. 2,018,990 AND 2,018,991.

NO CLAIM IS MADE TO THE EXCLUSIVE RIGHT TO USE "TOOLS", APART FROM THE MARK AS SHOWN.

FOR POWER TOOLS, NAMELY, HYDRAULIC COMPRESSION TOOLS, HYDRAULIC CUTTING TOOLS, BATTERY OPERATED COMPRESSION TOOLS AND BATTERY OPERATED CUTTING TOOLS; AND HYDRAULIC PUMPS (U.S. CLS. 13, 19, 21, 23, 31, 34 AND 35).

FIRST USE 12-31-1976; IN COMMERCE 12-31-1976.

WARREN L. OLANDRIA, EXAMINING ATTORNEY

SN 85-365,030. HUSKIE TOOLS, INC., GLENDALE HEIGHTS, IL. FILED 7-7-2011.



OWNER OF U.S. REG. NOS. 2,018,990 AND 2,018,991. NO CLAIM IS MADE TO THE EXCLUSIVE RIGHT TO USE "TOOLS", APART FROM THE MARK AS SHOWN.

THE COLOR(S) BLUE, ORANGE, GRAY AND WHITE IS/ARE CLAIMED AS A FEATURE OF THE MARK.

THE MARK CONSISTS OF AN ORANGE BLOCK "H" BEHIND A SILHOUETTE OF A BLUE MAN WEARING GLOVES AND OUTLINED IN WHITE AND HAVING A HARDHAT THAT IS WHITE WITH A BLUE OUTLINE, THE ELBOWS AND FINGERTIPS BEING WHITE, THE ARMS HOLDING AN ORANGE AND LIGHT BLUE GLOBE WITH A WHITE FLASH BETWEEN THE TWO HANDS AND A LIGHTNING BOLT EXTENDING TO THE SIDE FROM EACH GLOVE, THE BOLT BEING WHITE WITH A BLUE OUTLINE AND THE WORD "HUSKIE" IN BLUE TO THE RIGHT OF THE LETTER "H" AND THE WORD "TOOLS" IN GRAY BELOW THE WORD "HUSKIE".

FOR POWER TOOLS, NAMELY, HYDRAULIC COMPRESSION TOOLS, HYDRAULIC CUTTING TOOLS, BATTERY OPERATED COMPRESSION TOOLS AND BATTERY OPERATED CUTTING TOOLS; AND HYDRAULIC PUMPS (U.S. CLS. 13, 19, 21, 23, 31, 34 AND 35).

WARREN L. OLANDRIA, EXAMINING ATTORNEY

CLASS 7—(Continued).

SN 85-387,901. CMT GROUP, LLC, DBA TETON DYNAMICS, SAN LEANDRO, CA. FILED 8-3-2011.

TETON

THE MARK CONSISTS OF STANDARD CHARACTERS WITHOUT CLAIM TO ANY PARTICULAR FONT, STYLE, SIZE, OR COLOR.

FOR SUBMERSIBLE AND EXTERNAL WATER PUMPS AND COMPRESSED AIR PUMPS FOR PONDS, WATER GARDENS, FOUNTAINS, WATER FEATURES, POOLS, DEWATERING AND AQUARIUMS, AND REPLACEMENT PARTS AND RELATED PRODUCTS, NAMELY, PUMP PRE-FILTERS AND SCREENS, PUMP FOUNTAIN NOZZLES, PUMP ON AND OFF SWITCHES, PUMP TIMERS, PUMP CONTROL SYSTEMS, PUMP PLUMBING CONNECTION PARTS, PUMP TRANSFORMERS AND PUMP CLEANING PRODUCTS SOLD AS A UNIT THEREWITH, TO BE USED IN DOMESTIC, COMMERCIAL AND INDUSTRIAL APPLICATIONS (U.S. CLS. 13, 19, 21, 23, 31, 34 AND 35).

FIRST USE 6-0-2007; IN COMMERCE 6-0-2007.

ELLEN PERKINS, EXAMINING ATTORNEY

SN 85-389,319. GREEN WASTE STREAM, STRATHAM, NH. FILED 8-4-2011.



THE MARK CONSISTS OF THE TEXT "BIOGREEN360" ABOVE A GLOBE ENCIRCLED WITH RECYCLE ARROWS, AND A LEAF DOTTING THE "I".

FOR MACHINES, NAMELY, ORGANIC WASTE DIGESTER AND COMPOSTER TO ACCELERATE THE NATURAL DECOMPOSITION PROCESS OF ORGANIC WASTE THROUGH THE UTILIZATION OF ADVANCED PROPRIETARY MICROORGANISMS (U.S. CLS. 13, 19, 21, 23, 31, 34 AND 35).

FIRST USE 9-1-2010; IN COMMERCE 10-15-2010.

ALICE BENMAMAN, EXAMINING ATTORNEY

CLASS 7—(Continued).

SN 85-405,848. EURO-PRO OPERATING LLC, NEWTON, MA. FILED 8-24-2011.

NINJA PRECISION PULSE

THE MARK CONSISTS OF STANDARD CHARACTERS WITHOUT CLAIM TO ANY PARTICULAR FONT, STYLE, SIZE, OR COLOR.

OWNER OF U.S. REG. NO. 3,794,590.

NO CLAIM IS MADE TO THE EXCLUSIVE RIGHT TO USE "PULSE", APART FROM THE MARK AS SHOWN.

FOR ELECTRIC KITCHEN APPLIANCES FOR HOUSEHOLD USE, NAMELY, FOOD BLENDERS FOR DOMESTIC USE, CHOPPERS AND FOOD PROCESSORS, ELECTRIC MIXERS, ELECTRIC FOOD AND MEAT GRINDERS, ELECTRIC JUICERS, ELECTRIC JUICE EXTRACTORS, ELECTRIC FRUIT PRESSES, ELECTRIC FRUIT PEELERS, ELECTRIC FOOD SLICERS, ELECTRIC EGG BEATERS, ELECTRIC WHISKS, ELECTRIC GRATERS, ELECTRIC VEGETABLE PEELERS AND ELECTRIC PASTA MAKERS (U.S. CLS. 13, 19, 21, 23, 31, 34 AND 35).

ZACHARY BELLO, EXAMINING ATTORNEY

CLASS 7—(Continued).

SN 85-406,784. 3M COMPANY, ST. PAUL, MN. FILED 8-25-2011.

PPS

THE MARK CONSISTS OF STANDARD CHARACTERS WITHOUT CLAIM TO ANY PARTICULAR FONT, STYLE, SIZE, OR COLOR.

OWNER OF U.S. REG. NOS. 2,861,036, 2,863,680 AND 3,319,481.

FOR PAINT SPRAY EQUIPMENT, NAMELY, SPRAY GUN ADAPTERS, CUPS AND COLLARS, MINI CUPS, LIDS AND LINERS, LIDS WITH FILTERS, MIX RATIO INSERTS, DISPENSERS AND ACCESSORIES, NAMELY, SPRAY GUN HOLDERS, LID DISPENSERS, LINER DISPENSERS, AND CUP CARRIERS FOR THE PREPARATION OF PAINTS; KITS COMPRISING ONE OR MORE OF THE FOREGOING ITEMS (U.S. CLS. 13, 19, 21, 23, 31, 34 AND 35).

FIRST USE 9-2-2003; IN COMMERCE 9-2-2003.

KAREN SEVERSON, EXAMINING ATTORNEY

SN 85-406,783. 3M COMPANY, ST. PAUL, MN. FILED 8-25-2011.



OWNER OF U.S. REG. NOS. 2,861,036, 2,863,680 AND 3,319,481.

THE MARK CONSISTS OF THE LETTERS "PPS" IN STYLIZED FONT, TO THE RIGHT OF A PAINT SPRAYER, WITH THE NOZZLE AND SPRAY PARTIALLY OBSCURING THE LETTERS.

FOR PAINT SPRAY EQUIPMENT, NAMELY, SPRAY GUN ADAPTERS, CUPS AND COLLARS, MINI CUPS, LIDS AND LINERS, LIDS WITH FILTERS, MIX RATIO INSERTS, DISPENSERS AND ACCESSORIES, NAMELY, SPRAY GUN HOLDERS, LID DISPENSERS, LINER DISPENSERS, AND CUP CARRIERS FOR THE PREPARATION OF PAINTS; KITS COMPRISING ONE OR MORE OF THE FOREGOING ITEMS (U.S. CLS. 13, 19, 21, 23, 31, 34 AND 35).

FIRST USE 4-30-2004; IN COMMERCE 4-30-2004.

KAREN SEVERSON, EXAMINING ATTORNEY

SN 85-410,051. DOVER CORPORATION, NEW YORK, NY. FILED 8-29-2011.



OWNER OF U.S. REG. NOS. 4,035,317 AND 4,042,402.

NO CLAIM IS MADE TO THE EXCLUSIVE RIGHT TO USE "PUMP SOLUTIONS GROUP", APART FROM THE MARK AS SHOWN.

THE MARK CONSISTS OF SIX IDENTICAL SQUARES FORMING A SYMMETRICAL CHEVRON PATTERN POINTING UPWARD WITH EACH SQUARE HAVING A MAJOR DIAGONAL ALIGNED VERTICALLY WITHIN THE CHEVRON WITH EQUAL SPACING BETWEEN ALL ADJACENT SQUARES, "PSG" IN BLOCK LETTERS SYMMETRICALLY ARRANGED BENEATH THE CHEVRON AND WIDER THAN THE CHEVRON, "PUMP SOLUTIONS GROUP" IN BLOCK LETTERS SYMMETRICALLY ARRANGED BENEATH "PSG" AND OF EQUAL WIDTH.

FOR PUMPS, NAMELY, AIR-OPERATED DOUBLE-DIAPHRAGM PUMPS, POSITIVE DISPLACEMENT PUMPS, SLIDING VANE PUMPS, CENTRIFUGAL PUMPS, ECCENTRIC DISC PUMPS, ROTARY VANE PUMPS, LOBE PUMPS, SCREW COMPRESSOR PUMPS, PERISTALTIC HOSE PUMPS, HYDRAULIC DIAPHRAGM PUMPS, ELECTRONIC DIAPHRAGM PUMPS, PNEUMATIC DIAPHRAGM PUMPS, SUBMERSIBLE TURBINE PUMPS AND VERTICAL TURBINE PUMPS (U.S. CLS. 13, 19, 21, 23, 31, 34 AND 35).

FIRST USE 4-1-2011; IN COMMERCE 4-1-2011.

ALICIA COLLINS, EXAMINING ATTORNEY

CLASS 7—(Continued).

SN 85-420,689. NGIMAT CO., NORCROSS, GA. FILED 9-12-2011.

nanomiser

THE MARK CONSISTS OF STANDARD CHARACTERS WITHOUT CLAIM TO ANY PARTICULAR FONT, STYLE, SIZE, OR COLOR.

FOR LIQUID ATOMIZATION DEVICES FOR THE DISPERSION OF CHEMICAL AGENTS, NAMELY, POWER-OPERATED INDUSTRIAL ATOMIZERS FOR ATOMIZING PRECURSORS FOR CHEMICAL VAPOR DEPOSITION OF THIN FILM COATINGS; POWER-OPERATED ATOMIZING FUEL INJECTORS FOR INJECTING FUEL IN GASOLINE SPARK IGNITION ENGINES, COMPRESSION IGNITION ENGINES, HEAVY FUEL ENGINES, BIOFUEL ENGINES, MIXED FUEL ENGINES; POWER-OPERATED INDUSTRIAL ATOMIZERS FOR SPRAYING LIQUIDS IN THE MANUFACTURE AND SPRAY-DRYING OF DAIRY PRODUCTS, COFFEE, TEA, STARCHES, PHARMACEUTICALS, SOAPS, DETERGENTS AND PIGMENTS; POWER-OPERATED INDUSTRIAL ATOMIZERS FOR DISPERSING LIQUIDS CONTAINING POWDERED METALS FOR THE MANUFACTURE OF INDUSTRIAL COATINGS; POWER-OPERATED INDUSTRIAL ATOMIZERS FOR MATERIAL DISPERSION IN PARTICLE COATING DEVICES FOR PRODUCING PROTECTIVE COATINGS ON ELECTROMAGNETIC AND ELECTROPHORETIC PARTICLES; ATOMIZING FUEL INJECTORS INJECTING FUEL IN OIL BURNING FURNACES, OIL BURNING HEATERS, INDUSTRIAL BOILERS AND MARINE BOILERS AND SOLD AS AN INTEGRAL COMPONENT THEREOF; ATOMIZING FUEL INJECTORS FOR SPRAYING LIQUIDS IN SPRAY COOLING DEVICES IN THE NATURE OF SPRAY PONDS AND EVAPORATIVE TOWERS, NAMELY, EVAPORATIVE AIR COOLERS; ATOMIZING FUEL INJECTORS FOR INJECTING FUEL IN GASOLINE SPARK IGNITION ENGINES, COMPRESSION IGNITION ENGINES, HEAVY FUEL ENGINES, BIOFUEL ENGINES, MIXED FUEL ENGINES AIRCRAFT TURBINE ENGINES, MARINE TURBINE ENGINES, AUTOMOTIVE TURBINE ENGINES (U.S. CLS. 13, 19, 21, 23, 31, 34 AND 35).

DAWN HAN, EXAMINING ATTORNEY

SN 85-422,570. SENCO BRANDS, INC., CINCINNATI, OH. FILED 9-14-2011.

JOISTPRO

THE MARK CONSISTS OF STANDARD CHARACTERS WITHOUT CLAIM TO ANY PARTICULAR FONT, STYLE, SIZE, OR COLOR.

FOR POWER-OPERATED FASTENER-DRIVING TOOLS, NAMELY, NAILERS (U.S. CLS. 13, 19, 21, 23, 31, 34 AND 35).

SUNG IN, EXAMINING ATTORNEY

CLASS 7—(Continued).

SN 85-435,953. SHANGHAI LONGRICH BEARING COMPANY LIMITED, SHANGHAI, CHINA, FILED 9-30-2011.



THE MARK CONSISTS OF THE LETTERS "ZXB" IN STYLIZED FONT WITH TWO GEAR LIKE DESIGNS APPEARING IN THE "B".

FOR BEARINGS FOR TRANSMISSION SHAFTS, BEING PARTS OF MACHINES; BEARINGS, AS PARTS OF MACHINES; ENGINE BEARINGS; GEAR BOXES OTHER THAN FOR LAND VEHICLES; MACHINE PARTS, NAMELY, BEARINGS AND BUSHINGS; MACHINE PARTS, NAMELY, ROLLER BEARINGS; ROLLER BEARINGS FOR MACHINES; SHAFT BEARINGS FOR VACUUM PUMPS (U.S. CLS. 13, 19, 21, 23, 31, 34 AND 35).

FIRST USE 9-30-2011; IN COMMERCE 9-30-2011.
DANIEL CAPSHAW, EXAMINING ATTORNEY

SN 85-444,526. CARVIN POOL EQUIPMENT INC., HYACINTHE, QUEBEC, CANADA, FILED 10-11-2011.

CYGNET

THE MARK CONSISTS OF STANDARD CHARACTERS WITHOUT CLAIM TO ANY PARTICULAR FONT, STYLE, SIZE, OR COLOR.

FOR WATER PUMPS FOR USE IN SWIMMING POOLS (U.S. CLS. 13, 19, 21, 23, 31, 34 AND 35).

FIRST USE 11-0-1996; IN COMMERCE 11-0-1996.
ELLEN BURNS, EXAMINING ATTORNEY

SN 85-444,564. CANPLAS INDUSTRIES LTD., BARRIE, ONTARIO, CANADA, FILED 10-11-2011.

OWNER OF U.S. REG. NO. 2,954,834.

THE MARK CONSISTS OF A STYLIZED "H" IN A RECTANGLE APPEARING NEXT TO THE WORD "HAYDEN".

FOR CENTRAL VACUUM CLEANERS; CENTRAL VACUUM POWER UNITS; FITTINGS AND VALVES FOR CENTRAL VACUUMS; ATTACHMENTS FOR CENTRAL VACUUMS, NAMELY, NOZZLES, BRUSHES, HOSES, WANDS, EXTENSION TUBES, CREVICE TOOLS AND SQUEEGEES (U.S. CLS. 13, 19, 21, 23, 31, 34 AND 35).

FIRST USE 3-1-2007; IN COMMERCE 3-1-2007.
WON TEAK OH, EXAMINING ATTORNEY

CLASS 7—(Continued).

SN 85-445,440. TSUDAKOMA KOGYO KABUSHIKI KAISHA, ISHIKAWA-KEN, JAPAN, FILED 10-12-2011.

Weave Navigation

THE MARK CONSISTS OF STANDARD CHARACTERS WITHOUT CLAIM TO ANY PARTICULAR FONT, STYLE, SIZE, OR COLOR.

OWNER OF U.S. REG. NOS. 2,991,227 AND 2,991,228.

NO CLAIM IS MADE TO THE EXCLUSIVE RIGHT TO USE "WEAVE", APART FROM THE MARK AS SHOWN.

FOR SIZING MACHINES; DRYING MACHINES FOR TEXTILE MANUFACTURE; DRYING MACHINES, NAMELY, HOT AIR DRIERS FOR TEXTILE MANUFACTURE; YARN WARPING MACHINES; AUTOMATIC WEAVING LOOMS; STARCHING MACHINES (U.S. CLS. 13, 19, 21, 23, 31, 34 AND 35).

FIRST USE 4-1-2004; IN COMMERCE 2-28-2005.

COURTNEY ALVAREZ, EXAMINING ATTORNEY

SN 85-446,032. FATA HUNTER, INC., RIVERSIDE, CA. FILED 10-12-2011.

DUO-FEEDER

THE MARK CONSISTS OF STANDARD CHARACTERS WITHOUT CLAIM TO ANY PARTICULAR FONT, STYLE, SIZE, OR COLOR.

FOR MACHINERY PART, NAMELY, METAL WIRE FEEDER FOR METAL CASTING MACHINES FOR REFINING GRAIN OF CAST METAL (U.S. CLS. 13, 19, 21, 23, 31, 34 AND 35).

JEAN IM, EXAMINING ATTORNEY

SN 85-446,176. SCRAPY LAND INC, MIAMI, FL. FILED 10-13-2011.

DIE-VERSIONS

THE MARK CONSISTS OF STANDARD CHARACTERS WITHOUT CLAIM TO ANY PARTICULAR FONT, STYLE, SIZE, OR COLOR.

FOR DIE-CUTTING MACHINES; METAL DIES ADAPTED FOR USE WITH DIE-CUTTING MACHINES USED IN THE CRAFTS INDUSTRY (U.S. CLS. 13, 19, 21, 23, 31, 34 AND 35).

FIRST USE 10-1-2010; IN COMMERCE 10-1-2010.

ANDREA HACK, EXAMINING ATTORNEY

CLASS 7—(Continued).

SN 85-447,246. HEARTLAND ROBOTICS, INC., BOSTON, MA. FILED 10-13-2011.

BAXTER

THE MARK CONSISTS OF STANDARD CHARACTERS WITHOUT CLAIM TO ANY PARTICULAR FONT, STYLE, SIZE, OR COLOR.

FOR INDUSTRIAL ROBOTS FOR USE IN MANUFACTURING, ASSEMBLY AND DISTRIBUTION APPLICATIONS (U.S. CLS. 13, 19, 21, 23, 31, 34 AND 35).

DAVID I, EXAMINING ATTORNEY

SN 85-447,520. BSH HOME APPLIANCES CORPORATION, HUNTINGTON BEACH, CA. FILED 10-14-2011.

DUOPOWER

THE MARK CONSISTS OF STANDARD CHARACTERS WITHOUT CLAIM TO ANY PARTICULAR FONT, STYLE, SIZE, OR COLOR.

FOR DOUBLE SPRAY ARM FEATURE OF A DISHWASHER; STRUCTURAL PARTS OF ALL AFOREMENTIONED GOODS (U.S. CLS. 13, 19, 21, 23, 31, 34 AND 35).

KHANH LE, EXAMINING ATTORNEY

SN 85-447,971. INTERLINE BRANDS, INC., JACKSONVILLE, FL. FILED 10-14-2011.

RIPTIDE

THE MARK CONSISTS OF STANDARD CHARACTERS WITHOUT CLAIM TO ANY PARTICULAR FONT, STYLE, SIZE, OR COLOR.

FOR FOOD WASTE DISPOSALS; GARBAGE DISPOSALS (U.S. CLS. 13, 19, 21, 23, 31, 34 AND 35).

AMY KERTGATE, EXAMINING ATTORNEY

CLASS 7—(Continued).

SN 85-449,551. INDYMAKE, INC., INDIANAPOLIS, IN. FILED 10-18-2011.

INDYMAKER

THE MARK CONSISTS OF STANDARD CHARACTERS WITHOUT CLAIM TO ANY PARTICULAR FONT, STYLE, SIZE, OR COLOR.

FOR 3D PRINTERS FOR CREATING 3 DIMENSIONAL PLASTIC MODELS BY DEPOSITING PLASTIC LAYERS THROUGH THE USE OF COMPUTER SOFTWARE (U.S. CLS. 13, 19, 21, 23, 31, 34 AND 35).

LINDA E. BLOHM, EXAMINING ATTORNEY

CLASS 7—(Continued).

SN 85-449,989. MERCER TOOL CORP., DEER PARK, NY. FILED 10-18-2011.

BLUE LIGHTNING

THE MARK CONSISTS OF STANDARD CHARACTERS WITHOUT CLAIM TO ANY PARTICULAR FONT, STYLE, SIZE, OR COLOR.

OWNER OF U.S. REG. NO. 2,894,965.

FOR CUTTING DISCS FOR POWER-OPERATED MACHINE TOOLS; CUTTING DISCS FOR POWER-OPERATED HAND TOOLS (U.S. CLS. 13, 19, 21, 23, 31, 34 AND 35).

MARK RADEMACHER, EXAMINING ATTORNEY

SN 85-449,556. SNOWIZARD, INC., JEFFERSON, LA. FILED 10-18-2011.

SNOWIZARD SNOBALL MACHINE

THE MARK CONSISTS OF STANDARD CHARACTERS WITHOUT CLAIM TO ANY PARTICULAR FONT, STYLE, SIZE, OR COLOR.

OWNER OF U.S. REG. NOS. 2,544,216 AND 3,669,146.

NO CLAIM IS MADE TO THE EXCLUSIVE RIGHT TO USE "SNOWBALL MACHINE", APART FROM THE MARK AS SHOWN.

FOR ICE SHAVING MACHINES (U.S. CLS. 13, 19, 21, 23, 31, 34 AND 35).

FIRST USE 4-30-1948; IN COMMERCE 4-30-1948.

JOHN HWANG, EXAMINING ATTORNEY

SN 85-450,003. MERCER TOOL CORP., DEER PARK, NY. FILED 10-18-2011.

SILVER LIGHTNING

THE MARK CONSISTS OF STANDARD CHARACTERS WITHOUT CLAIM TO ANY PARTICULAR FONT, STYLE, SIZE, OR COLOR.

OWNER OF U.S. REG. NO. 2,894,965.

FOR CUTTING DISCS FOR POWER-OPERATED MACHINE TOOLS; CUTTING DISCS FOR POWER-OPERATED HAND TOOLS (U.S. CLS. 13, 19, 21, 23, 31, 34 AND 35).

MARK RADEMACHER, EXAMINING ATTORNEY

SN 85-449,956. THANE INTERNATIONAL, INC., LA QUINTA, CA. FILED 10-18-2011.

H2O X5

THE MARK CONSISTS OF STANDARD CHARACTERS WITHOUT CLAIM TO ANY PARTICULAR FONT, STYLE, SIZE, OR COLOR.

OWNER OF U.S. REG. NOS. 3,425,675, 4,007,640 AND OTHERS.

FOR STEAM CLEANING MACHINES (U.S. CLS. 13, 19, 21, 23, 31, 34 AND 35).

FIRST USE 1-8-2011; IN COMMERCE 3-21-2011.

JILL PRATER, EXAMINING ATTORNEY

SN 85-450,066. HOLLYMATIC CORPORATION, COUNTRY-SIDE, IL. FILED 10-18-2011.

INVISIBLE GUARD

THE MARK CONSISTS OF STANDARD CHARACTERS WITHOUT CLAIM TO ANY PARTICULAR FONT, STYLE, SIZE, OR COLOR.

NO CLAIM IS MADE TO THE EXCLUSIVE RIGHT TO USE "GUARD", APART FROM THE MARK AS SHOWN.

FOR ELECTRIC FOOD PROCESSORS (U.S. CLS. 13, 19, 21, 23, 31, 34 AND 35).

KAREN K. BUSH, EXAMINING ATTORNEY

CLASS 7—(Continued).

SN 85-450,199. GREENE ENVIRONMENTAL CORPORATION, BOSTON, MA. FILED 10-18-2011.

ENVIOPIPE

THE MARK CONSISTS OF STANDARD CHARACTERS WITHOUT CLAIM TO ANY PARTICULAR FONT, STYLE, SIZE, OR COLOR.

FOR EXHAUST FILTERS FOR MOTORS AND ENGINES (U.S. CLS. 13, 19, 21, 23, 31, 34 AND 35).
ZACHARY BELLO, EXAMINING ATTORNEY

SN 85-450,472. APPLIED MATERIALS, INC, SANTA CLARA, CA. FILED 10-18-2011.

VOLTA

THE MARK CONSISTS OF STANDARD CHARACTERS WITHOUT CLAIM TO ANY PARTICULAR FONT, STYLE, SIZE, OR COLOR.

FOR EQUIPMENT AND MACHINES FOR THE PROCESSING AND PRODUCTION OF SEMICONDUCTOR SUBSTRATES, THIN FILMS, SILICON DISCS AND WAFERS, INCLUDING POLISHING, CLEANING, PROCESS MONITORING, AND SEMICONDUCTOR MEASURING EQUIPMENT (U.S. CLS. 13, 19, 21, 23, 31, 34 AND 35).

TINA MAI, EXAMINING ATTORNEY

SN 85-462,639. BELANGER, INC., NORTHVILLE, MI. FILED 11-2-2011.

Illumatex

THE MARK CONSISTS OF STANDARD CHARACTERS WITHOUT CLAIM TO ANY PARTICULAR FONT, STYLE, SIZE, OR COLOR.

FOR AUTOMATIC VEHICLE WASHING EQUIPMENT (U.S. CLS. 13, 19, 21, 23, 31, 34 AND 35).

MEGHAN REINHART, EXAMINING ATTORNEY

CLASS 7—(Continued).

SN 85-470,648. THANE INTERNATIONAL, INC., LA QUINTA, CA. FILED 11-11-2011.

STEAM LAZER

THE MARK CONSISTS OF STANDARD CHARACTERS WITHOUT CLAIM TO ANY PARTICULAR FONT, STYLE, SIZE, OR COLOR.

NO CLAIM IS MADE TO THE EXCLUSIVE RIGHT TO USE "STEAM", APART FROM THE MARK AS SHOWN.

FOR STEAM CLEANING MACHINE PARTS, NAMELY, NOZZLES; STEAM CLEANING MACHINES (U.S. CLS. 13, 19, 21, 23, 31, 34 AND 35).

JILL PRATER, EXAMINING ATTORNEY

SN 85-472,644. THE BLACK & DECKER CORPORATION, TOWSON, MD. FILED 11-15-2011.

A NEW TWIST ON SCREWDRIVING

THE MARK CONSISTS OF STANDARD CHARACTERS WITHOUT CLAIM TO ANY PARTICULAR FONT, STYLE, SIZE, OR COLOR.

FOR POWER-OPERATED SCREWDRIVERS (U.S. CLS. 13, 19, 21, 23, 31, 34 AND 35).

MARK RADEMACHER, EXAMINING ATTORNEY

SN 85-487,924. BSH HOME APPLIANCES CORPORATION, IRVINE, CA. FILED 12-6-2011.

TOPAZ

THE MARK CONSISTS OF STANDARD CHARACTERS WITHOUT CLAIM TO ANY PARTICULAR FONT, STYLE, SIZE, OR COLOR.

FOR HOUSEHOLD AND KITCHEN MACHINES AND EQUIPMENT, NAMELY, ELECTRIC KITCHEN MACHINES AND EQUIPMENT, NAMELY, DISHWASHERS; STRUCTURAL PARTS OF ALL AFOREMENTIONED GOODS (U.S. CLS. 13, 19, 21, 23, 31, 34 AND 35).

KHANH LE, EXAMINING ATTORNEY

CLASS 7—(Continued).

SN 85-517,995. MAYTAG PROPERTIES, LLC, ST. JOSEPH, MI. FILED 1-17-2012.

MAYTAG

THE MARK CONSISTS OF STANDARD CHARACTERS WITHOUT CLAIM TO ANY PARTICULAR FONT, STYLE, SIZE, OR COLOR.

OWNER OF U.S. REG. NOS. 2,638,631, 3,811,414 AND OTHERS.

FOR ELECTRICITY GENERATORS (U.S. CLS. 13, 19, 21, 23, 31, 34 AND 35).

DAVID H. STINE, EXAMINING ATTORNEY

CLASS 8—(Continued).

SN 85-094,923. CISCO SALES CORPORATION, TORRANCE, CA. FILED 7-28-2010.

1.2.3 Miracle Sharpener

THE MARK CONSISTS OF STANDARD CHARACTERS WITHOUT CLAIM TO ANY PARTICULAR FONT, STYLE, SIZE, OR COLOR.

NO CLAIM IS MADE TO THE EXCLUSIVE RIGHT TO USE "SHARPENER", APART FROM THE MARK AS SHOWN.

FOR MANUALLY OPERATED SHARPENERS (U.S. CLS. 23, 28 AND 44).

FIRST USE 2-24-2011; IN COMMERCE 2-24-2011.
SUNG IN, EXAMINING ATTORNEY

CLASS 8—HAND TOOLS

SN 77-820,893. ROCKLER COMPANIES, INC., MEDINA, MN. FILED 9-4-2009.

BENCH COOKIE

THE MARK CONSISTS OF STANDARD CHARACTERS WITHOUT CLAIM TO ANY PARTICULAR FONT, STYLE, SIZE, OR COLOR.

NO CLAIM IS MADE TO THE EXCLUSIVE RIGHT TO USE "BENCH", APART FROM THE MARK AS SHOWN.

FOR HAND TOOLS, NAMELY, NON-SLIP WORK-PIECE SUPPORT DEVICES FOR WOODWORKING (U.S. CLS. 23, 28 AND 44).

FIRST USE 7-20-2009; IN COMMERCE 7-20-2009.
ANNE FARRELL, EXAMINING ATTORNEY

SN 85-301,611. LEHMAN BROTHERS HOLDINGS INC., NEW YORK, NY. FILED 4-21-2011.

SETAI

THE MARK CONSISTS OF STANDARD CHARACTERS WITHOUT CLAIM TO ANY PARTICULAR FONT, STYLE, SIZE, OR COLOR.

FOR TABLEWARE, NAMELY, KNIVES, FORKS, SPOONS AND CUTLERY (U.S. CLS. 23, 28 AND 44).

KATHERINE CHANG, EXAMINING ATTORNEY

SN 79-090,369. KONINKLIJKE PHILIPS ELECTRONICS N.V., NETHERLANDS, FILED 11-8-2010.

HEADROOM

THE MARK CONSISTS OF STANDARD CHARACTERS WITHOUT CLAIM TO ANY PARTICULAR FONT, STYLE, SIZE, OR COLOR.

PRIORITY DATE OF 5-10-2010 IS CLAIMED.

OWNER OF INTERNATIONAL REGISTRATION 1059547 DATED 11-8-2010, EXPIRES 11-8-2020.

FOR ELECTRIC RAZORS, BLADES FOR ELECTRIC RAZORS, HAIR CLIPPERS, HAIR AND BEARD TRIMMERS (U.S. CLS. 23, 28 AND 44).

CHRISTOPHER BUONGIORNO, EXAMINING ATTORNEY

SN 85-436,070. SUNBEAM PRODUCTS, INC., BOCA RATON, FL. FILED 9-30-2011.

Free Rider

OWNER OF U.S. REG. NO. 3,979,296.

THE MARK CONSISTS OF THE WORD "FREE" IN A CURSIVE SCRIPT POSITIONED ABOVE AND TO THE LEFT OF THE WORD "RIDER" WITH THE LETTERS "REE" IN THE WORD "FREE" EXTENDING ABOVE THE LETTERS "RI" IN THE WORD "RIDER".

FOR ELECTRIC HAIR CLIPPERS AND TRIMMERS FOR HUMAN USE (U.S. CLS. 23, 28 AND 44).

FIRST USE 10-31-2010; IN COMMERCE 10-31-2010.
JULIE GUTTADAURO, EXAMINING ATTORNEY

CLASS 8—(Continued).

SN 85-446,371. SOMARK INNOVATIONS, INC., SAN DIEGO, CA. FILED 10-13-2011.

LABSTAMP

THE MARK CONSISTS OF STANDARD CHARACTERS WITHOUT CLAIM TO ANY PARTICULAR FONT, STYLE, SIZE, OR COLOR.

FOR TATTOO MACHINES FOR TAGGING OF LABORATORY ANIMALS AND PETS FOR IDENTIFICATION PURPOSES (U.S. CLS. 23, 28 AND 44).

FIRST USE 6-1-2009; IN COMMERCE 3-1-2010.
DOMINIC FATHY, EXAMINING ATTORNEY

CLASS 8—(Continued).

SN 85-447,806. FERRY, KIM M, WESTLAKE VILLAGE, CA. FILED 10-14-2011.



THE MARK CONSISTS OF STYLIZED DESIGN OF A WINGED FAIRY WITH LONG, WAVY HAIR RIDING THE CREST OF A DOUBLE WAVE ENCLOSED IN A CIRCLE.

FOR TOOL HOLDERS (U.S. CLS. 23, 28 AND 44).
GEORGE LORENZO, EXAMINING ATTORNEY

SN 85-446,797. OLE-SOUTH CUSTOM KNIVES, CROSS CITY, FL. FILED 10-13-2011.

OLE-SOUTH custom knives

THE MARK CONSISTS OF STANDARD CHARACTERS WITHOUT CLAIM TO ANY PARTICULAR FONT, STYLE, SIZE, OR COLOR.

NO CLAIM IS MADE TO THE EXCLUSIVE RIGHT TO USE "CUSTOM KNIVES", APART FROM THE MARK AS SHOWN.

FOR HUNTING KNIVES (U.S. CLS. 23, 28 AND 44).
KRISTIN DAHLING, EXAMINING ATTORNEY

SN 85-460,190. THE GILLETTE COMPANY, BOSTON, MA. FILED 10-31-2011.



SN 85-447,679. KIM M FERRY, WESTLAKE VILLAGE, CA. FILED 10-14-2011.

HairFerry

THE MARK CONSISTS OF STANDARD CHARACTERS WITHOUT CLAIM TO ANY PARTICULAR FONT, STYLE, SIZE, OR COLOR.

FOR TOOL HOLDERS (U.S. CLS. 23, 28 AND 44).
JAMES MACFARLANE, EXAMINING ATTORNEY

THE MARK CONSISTS OF THE THREE DOWNWARD FACING ARCS THAT APPEAR ON THE RAZOR HANDLE. THE IMAGE OF THE RAZOR, WITH BOTH HEAD AND HANDLE, APPEAR IN DOTTED LINES TO SHOW POSITION, AND ARE NOT CLAIMED AS PART OF THE MARK.

FOR RAZORS AND RAZOR BLADES; DISPENSERS, CASSETTES, HOLDERS, AND CARTRIDGES, ALL CONTAINING RAZOR BLADES; AND STRUCTURAL PARTS THEREFOR (U.S. CLS. 23, 28 AND 44).

FIRST USE 6-22-1998; IN COMMERCE 6-22-1998.
FRANK LATTUCA, EXAMINING ATTORNEY

CLASS 8—(Continued).

SN 85-475,931. FLEET WHOLESALE SUPPLY CO., INC.,
APPLETON, WI. FILED 11-17-2011.

LEGION INDUSTRIAL TOOLS

THE MARK CONSISTS OF STANDARD CHARACTERS
WITHOUT CLAIM TO ANY PARTICULAR FONT, STYLE,
SIZE, OR COLOR.

NO CLAIM IS MADE TO THE EXCLUSIVE RIGHT TO
USE "INDUSTRIAL TOOLS", APART FROM THE MARK AS
SHOWN.

FOR HAND TOOLS, NAMELY, PLIERS, SCREWDRI-
VERS, AXES, MAULS, SLEDGE HAMMERS, SAWS,
UTILITY KNIVES (U.S. CLS. 23, 28 AND 44).
MARY ROSSMAN, EXAMINING ATTORNEY

SN 85-495,258. WAHL CLIPPER CORPORATION, STER-
LING, IL. FILED 12-14-2011.

SUPER HERO

THE MARK CONSISTS OF STANDARD CHARACTERS
WITHOUT CLAIM TO ANY PARTICULAR FONT, STYLE,
SIZE, OR COLOR.

OWNER OF U.S. REG. NO. 3,703,384.
FOR ELECTRIC AND BATTERY-POWERED HAIR
CLIPPERS; ELECTRIC AND BATTERY-POWERED HAIR
TRIMMERS (U.S. CLS. 23, 28 AND 44).
TASNEEM HUSSAIN, EXAMINING ATTORNEY

SN 85-508,180. AMES TRUE TEMPER, INC., CAMP HILL, PA.
FILED 1-4-2012.

TERMINATOR

THE MARK CONSISTS OF STANDARD CHARACTERS
WITHOUT CLAIM TO ANY PARTICULAR FONT, STYLE,
SIZE, OR COLOR.

FOR MAULS AND SLEDGEHAMMERS (U.S. CLS. 23,
28 AND 44).
CARYN GLASSER, EXAMINING ATTORNEY

**CLASS 9—ELECTRICAL AND SCIENTIFIC
APPARATUS**

SN 76-706,932. TURTURRO, MICHAEL, WANTAGH, NY.
FILED 3-22-2011.

ROCKULTA

THE MARK CONSISTS OF STANDARD CHARACTERS
WITHOUT CLAIM TO ANY PARTICULAR FONT, STYLE,
SIZE, OR COLOR.

FOR DIGITAL MEDIA, NAMELY, PRE-RECORDED
COMPACT DISCS FEATURING MUSIC; DIGITAL ME-
DIA, NAMELY, DOWNLOADABLE AUDIO RECORDINGS
FEATURING MUSIC (U.S. CLS. 21, 23, 26, 36 AND 38).

FIRST USE 11-1-2004; IN COMMERCE 11-1-2004.
CHARLOTTE CORWIN, EXAMINING ATTORNEY

SN 76-707,239. E&B GIFTWARE, LLC, YONKERS, NY.
FILED 4-12-2011.

InSpire

THE MARK CONSISTS OF STANDARD CHARACTERS
WITHOUT CLAIM TO ANY PARTICULAR FONT, STYLE,
SIZE, OR COLOR.

FOR A SENSOR WITH VISUAL DISPLAY TO BE
WORN ON A PERSON WHILE EXERCISING USING
AN ACCELEROMETER TO MEASURE MOVEMENT
(U.S. CLS. 21, 23, 26, 36 AND 38).

ALLISON HOLTZ, EXAMINING ATTORNEY

SN 76-707,393. PASCO SCIENTIFIC, ROSEVILLE, CA. FILED
4-25-2011.

SPARKLABS

THE MARK CONSISTS OF STANDARD CHARACTERS
WITHOUT CLAIM TO ANY PARTICULAR FONT, STYLE,
SIZE, OR COLOR.

FOR DIGITAL MEDIA, NAMELY, CDS AND DVDS
FEATURING DIGITAL INSTRUCTIONAL, EDUCA-
TIONAL, AND TEACHING MATERIALS IN THE NATURE
OF SCIENTIFIC EXPERIMENTS AND LESSONS IN
THE FIELDS OF BIOLOGY, CHEMISTRY, EARTH
SCIENCE, AND PHYSICS FOR MIDDLE SCHOOL, AND
COMPUTER SOFTWARE AND APPLICATIONS FOR
MOBILE PHONES, SMART PHONES, PERSONAL DIGI-
TAL ASSISTANTS, LAPTOP COMPUTERS, DESKTOP
COMPUTERS, AND TABLET COMPUTERS FEATURING
DIGITAL INSTRUCTIONAL, EDUCATIONAL AND
TEACHING MATERIALS IN THE NATURE OF ELE-
MENTARY SCHOOL SCIENCE PROJECTS THAT ARE
PERFORMED USING A GRAPHIC INTERFACE (U.S.
CLS. 21, 23, 26, 36 AND 38).

ANTHONY RINKER, EXAMINING ATTORNEY

CLASS 9—(Continued).

SN 76-707,456. SIGNATURE CONTROL SYSTEMS, INC., IRVINE, CA. FILED 5-2-2011.

EZ PRO

THE MARK CONSISTS OF STANDARD CHARACTERS WITHOUT CLAIM TO ANY PARTICULAR FONT, STYLE, SIZE, OR COLOR.

FOR AUTOMATIC IRRIGATION AND WATERING CONTROLS, NAMELY, ELECTRONIC WATER TIMERS AND CONTROL (U.S. CLS. 21, 23, 26, 36 AND 38).

FIRST USE 11-15-2000; IN COMMERCE 2-15-2001.
CHRISIE B. KING, EXAMINING ATTORNEY

SN 76-707,824. ROLAND CORPORATION, HAMAMATSU, SHIZUOKA, JAPAN, FILED 5-27-2011.

CUBE MONITOR

THE MARK CONSISTS OF STANDARD CHARACTERS WITHOUT CLAIM TO ANY PARTICULAR FONT, STYLE, SIZE, OR COLOR.

OWNER OF U.S. REG. NOS. 3,167,277 AND 3,360,211.
NO CLAIM IS MADE TO THE EXCLUSIVE RIGHT TO USE "MONITOR", APART FROM THE MARK AS SHOWN.

FOR AUDIO AMPLIFIER WITH SPEAKER FOR MONITORING MUSICAL INSTRUMENTS, VOCALS, AND AUDIO REPRODUCTION (U.S. CLS. 21, 23, 26, 36 AND 38).

FIRST USE 9-10-2004; IN COMMERCE 9-0-2004.
SUZANNE BLANE, EXAMINING ATTORNEY

SN 76-707,926. INTERNATIONAL RECTIFIER CORPORATION, EL SEGUNDO, CA. FILED 6-10-2011.

COOLiR-Stack

OWNER OF U.S. REG. NO. 1,551,719.
THE MARK CONSISTS OF THE WORDING "COOLIR-STACK" IN STYLIZED FONT WHERE ALL LETTERS ARE CAPITALIZED, EXCEPT THE LETTERS "I" AND "TACK".

FOR ELECTRICAL AND ELECTRONIC CIRCUITS, SEMICONDUCTOR DEVICES AND PACKAGES IN THE NATURE OF HOUSINGS ESPECIALLY ADAPTED FOR SEMICONDUCTOR DEVICES, AND DEVICES FOR POWER CONVERSION, VOLTAGE CONVERSION, POWER MANAGEMENT AND/OR DELIVERY OF POWER, NAMELY, BUCK CONVERTERS, DC-DC CONVERTERS, AC-DC CONVERTERS, DC-AC CONVERTERS, AC-AC CONVERTERS, RECTIFIERS, POWER FACTOR CONVERSION CIRCUITS, FULL-BRIDGE CIRCUITS AND HALF-BRIDGE CIRCUITS (U.S. CLS. 21, 23, 26, 36 AND 38).

BERNICE MIDDLETON, EXAMINING ATTORNEY

CLASS 9—(Continued).

SN 76-707,929. INTERNATIONAL RECTIFIER CORPORATION, EL SEGUNDO, CA. FILED 6-10-2011.

COOLiR²-Stack

OWNER OF U.S. REG. NO. 1,551,719.

THE MARK CONSISTS OF THE WORDING "COOLIR2-STACK" IN STYLIZED FONT WHERE ALL LETTERS ARE CAPITALIZED, EXCEPT THE LETTERS "I" AND "TACK". THE NUMBER "2" APPEARS IN SUPERSCRIPT.

FOR ELECTRICAL AND ELECTRONIC CIRCUITS, SEMICONDUCTOR DEVICES AND PACKAGES IN THE NATURE OF HOUSINGS ESPECIALLY ADAPTED FOR SEMICONDUCTOR DEVICES, AND DEVICES FOR POWER CONVERSION, VOLTAGE CONVERSION, POWER MANAGEMENT AND/OR DELIVERY OF POWER, NAMELY, BUCK CONVERTERS, DC-DC CONVERTERS, AC-DC CONVERTERS, DC-AC CONVERTERS, AC-AC CONVERTERS, RECTIFIERS, POWER FACTOR CONVERSION CIRCUITS, FULL-BRIDGE CIRCUITS AND HALF-BRIDGE CIRCUITS (U.S. CLS. 21, 23, 26, 36 AND 38).

BERNICE MIDDLETON, EXAMINING ATTORNEY

SN 77-000,542. VITAL ALERT COMMUNICATION INC., HUNTSVILLE, ONTARIO, CANADA, FILED 9-15-2006.

Canary

PRIORITY CLAIMED UNDER SEC. 44(D) ON CANADA APPLICATION NO. 1,293,954, FILED 3-16-2006, REG. NO. TMA814854, DATED 1-4-2012, EXPIRES 1-4-2027.

FOR WIRELESS COMMUNICATIONS DEVICES, NAMELY, RECEIVERS, TRANSMITTERS, AND ANTENNAS, WHICH ALLOW TWO-WAY DATA AND SENSOR COMMUNICATION THROUGH SOLID OBSTRUCTIONS SUCH AS EARTH, ROCK AND CONCRETE (U.S. CLS. 21, 23, 26, 36 AND 38).

PRISCILLA MILTON, EXAMINING ATTORNEY

CLASS 9—(Continued).

SN 77-497,724. HILLERICH & BRADSBY CO., LOUISVILLE, KY. FILED 6-12-2008.

SLUGGER

THE MARK CONSISTS OF STANDARD CHARACTERS WITHOUT CLAIM TO ANY PARTICULAR FONT, STYLE, SIZE, OR COLOR.

OWNER OF U.S. REG. NOS. 1,417,502, 2,598,943 AND OTHERS.

FOR VIDEO GAME DISCS, VIDEO GAME SOFTWARE, VIDEO GAME PROGRAMS, AND PRINTED INSTRUCTIONAL MATERIALS INCLUDED THEREWITH; COMPUTER GAME DISCS, COMPUTER GAME SOFTWARE, COMPUTER GAME PROGRAMS, AND PRINTED INSTRUCTIONAL MATERIALS INCLUDED THEREWITH (U.S. CLS. 21, 23, 26, 36 AND 38).

COLLEEN KEARNEY, EXAMINING ATTORNEY

SN 77-731,866. NOVARTIS AG, BASEL, SWITZERLAND, FILED 5-7-2009.

DAILIES TOTAL1

THE MARK CONSISTS OF STANDARD CHARACTERS WITHOUT CLAIM TO ANY PARTICULAR FONT, STYLE, SIZE, OR COLOR.

OWNER OF SWITZERLAND REG. NO. 585355, DATED 4-6-2009, EXPIRES 4-6-2019.

OWNER OF U.S. REG. NOS. 2,167,845 AND 3,555,421. FOR CONTACT LENSES (U.S. CLS. 21, 23, 26, 36 AND 38).

SUNG IN, EXAMINING ATTORNEY

SN 77-877,622. CRESTRON ELECTRONICS, INC., ROCK-LEIGH, NJ. FILED 11-20-2009.

V-Panel

THE MARK CONSISTS OF STANDARD CHARACTERS WITHOUT CLAIM TO ANY PARTICULAR FONT, STYLE, SIZE, OR COLOR.

FOR ELECTRIC CONTROL PANELS FOR HOME THEATER AND MULTIMEDIA SYSTEMS; FLAT PANEL DISPLAY SCREENS FOR HOME THEATER AND MULTIMEDIA SYSTEMS; LCD PANELS FOR HOME THEATER AND MULTIMEDIA SYSTEMS; LIGHTING CONTROL PANELS; TOUCH PANELS FOR HOME THEATER AND MULTIMEDIA SYSTEMS (U.S. CLS. 21, 23, 26, 36 AND 38).

JORDAN BAKER, EXAMINING ATTORNEY

CLASS 9—(Continued).

SN 77-933,856. CYTOGNOS S.L., SALAMANCA, SPAIN, FILED 2-11-2010.



OWNER OF ERPN CMNTY TM OFC REG. NO. 5625207, DATED 2-18-2008, EXPIRES 1-18-2017.

THE COLOR(S) GREY, ORANGE AND BROWN IS/ARE CLAIMED AS A FEATURE OF THE MARK.

THE MARK CONSISTS OF THE WORD "INFINICYT" IN STYLIZED FORM IN GREY AND TWO INTERLOCKING RINGS IN ORANGE AND BROWN.

FOR SOFTWARE FOR ANALYZING DATA OBTAINED FROM BIOLOGICAL SAMPLES ACQUIRED BY A FLOW CYTOMETER (U.S. CLS. 21, 23, 26, 36 AND 38).

FIRST USE 11-12-2008; IN COMMERCE 11-12-2008.

MICHAEL SOUDERS, EXAMINING ATTORNEY

SN 77-942,432. SESTUS LLC, AVONDALE, AZ. FILED 2-23-2010.

VIRTUAL TOKEN

THE MARK CONSISTS OF STANDARD CHARACTERS WITHOUT CLAIM TO ANY PARTICULAR FONT, STYLE, SIZE, OR COLOR.

SEC. 2(F).

FOR COMPUTER SOFTWARE FOR USE IN AUTHENTICATION, IDENTIFICATION VERIFICATION AND FRAUD PREVENTION (U.S. CLS. 21, 23, 26, 36 AND 38).

FIRST USE 3-0-2005; IN COMMERCE 3-0-2005.

REBECCA EISINGER, EXAMINING ATTORNEY

CLASS 9—(Continued).

SN 77-944,043. BBY SOLUTIONS, INC., RICHFIELD, MN. FILED 2-24-2010.

APCESSORIES

THE MARK CONSISTS OF STANDARD CHARACTERS WITHOUT CLAIM TO ANY PARTICULAR FONT, STYLE, SIZE, OR COLOR.

FOR CONSUMER ELECTRONICS ACCESSORIES FOR PORTABLE DIGITAL VIDEO AND DIGITAL AUDIO PLAYERS INTENDED FOR AUTOMOTIVE, HOME AND MARINE USE, NAMELY, PERIPHERAL HARDWARE IN THE NATURE OF ELECTRONIC DOCKING STATIONS AND RADIOFREQUENCY COMMUNICATION TRANSMITTERS AND RECEIVERS USED IN SHORT-RANGE TRANSMISSION OF DATA, AND INTEGRATED SOFTWARE IN THE NATURE OF GAME SOFTWARE AND UTILITY PROGRAMS; ACCESSORY KITS FOR PORTABLE DIGITAL VIDEO AND DIGITAL AUDIO PLAYERS COMPRISING DOCKING STATIONS AND RADIOFREQUENCY COMMUNICATION TRANSMITTERS AND RECEIVERS USED IN SHORT-RANGE TRANSMISSION OF DATA; WIRED AND WIRELESS LINKS BETWEEN SOFTWARE INTERFACES AND PERIPHERAL HARDWARE FOR PORTABLE DIGITAL VIDEO AND DIGITAL AUDIO PLAYERS, NAMELY, USB (UNIVERSAL SERIAL BUS) HARDWARE AND OPERATING SOFTWARE, WIRED ASYNCHRONOUS SERIAL INTERFACE HARDWARE AND OPERATING SOFTWARE, AND WIRELESS RADIOFREQUENCY COMMUNICATION LINKS (U.S. CLS. 21, 23, 26, 36 AND 38).

NICHOLAS ALTREE, EXAMINING ATTORNEY

SN 77-959,178. RECONROBOTICS, INC., EDINA, MN. FILED 3-15-2010.

RECON SKYSCOUT

THE MARK CONSISTS OF STANDARD CHARACTERS WITHOUT CLAIM TO ANY PARTICULAR FONT, STYLE, SIZE, OR COLOR.

OWNER OF U.S. REG. NO. 3,463,141. SEC. 2(F) AS TO "RECON".

FOR AUTONOMOUS MOBILE ROBOTS TO BE USED WORLDWIDE IN SECURITY, RECONNAISSANCE, SURVEILLANCE, ACCESS CONTROL, HAZMAT AND FIRST RESPONDER SITUATIONS BY MILITARY, LOCAL, STATE AND FEDERAL AUTHORITIES, POLICE, SWAT, SECURITY AGENCIES, PRIVATE SECURITY FIRMS AND INDUSTRIES HANDLING HAZARDOUS OR DANGEROUS MATERIAL (U.S. CLS. 21, 23, 26, 36 AND 38).

ELLEN PERKINS, EXAMINING ATTORNEY

CLASS 9—(Continued).

SN 77-966,010. LARCAN INC., MISSISSAUGA, ON, CANADA, FILED 3-23-2010.

PULSE

THE MARK CONSISTS OF STANDARD CHARACTERS WITHOUT CLAIM TO ANY PARTICULAR FONT, STYLE, SIZE, OR COLOR.

FOR DIGITAL MODULATORS USED BY TELEVISION BROADCASTERS TO BOOST AND MODULATE LOW POWER SIGNALS INTO AN ATSC-COMPLIANT (ADVANCED TELEVISION SYSTEMS COMMITTEE COMPLIANT). SIGNAL THAT CAN BE DELIVERED OVER CABLE, SATELLITE, AND TERRESTRIAL NETWORKS (U.S. CLS. 21, 23, 26, 36 AND 38).

FIRST USE 6-2-2008; IN COMMERCE 6-2-2008.

LINDA MICKLEBURGH, EXAMINING ATTORNEY

SN 77-981,831. TORRENTE, 92038 PARIS LA DÉFENSE, FRANCE, FILED 12-22-2009.

TORRENTE

OWNER OF FRANCE REG. NO. 1588661, DATED 9-13-1989, EXPIRES 9-13-2019.

THE MARK CONSISTS OF THE WORD "TORRENTE" ABOVE A DESIGN IN THE NATURE OF TWO COLUMNS, ONE LYING HORIZONTALLY AND THE OTHER STANDING VERTICALLY ON TOP OF THE HORIZONTAL COLUMN.

THE ENGLISH TRANSLATION OF "TORRENTE" IS "TORRENT".

FOR EYEGLASSES AND SUNGLASSES; CAMERA CASES MADE OF LEATHER OR IMITATIONS OF LEATHER; LEATHER EYEGLASS CASES (U.S. CLS. 21, 23, 26, 36 AND 38).

CHRISTINE COOPER, EXAMINING ATTORNEY

CLASS 9—(Continued).

SN 79-090,509. DYESOL INDUSTRIES PTY LTD, AUSTRALIA, FILED 10-6-2010.



PRIORITY DATE OF 4-7-2010 IS CLAIMED.
OWNER OF INTERNATIONAL REGISTRATION 1059863
DATED 10-6-2010, EXPIRES 10-6-2020.

OWNER OF U.S. REG. NO. 3,194,428.

THE COLOR(S) RED AND YELLOW IS/ARE CLAIMED AS A FEATURE OF THE MARK.

THE MARK CONSISTS OF THE WORDING "DYESOL". "DYE" IS IN RED AND "SOL" IS IN YELLOW. A DESIGN ELEMENT OF A YELLOW SUN SUBSTITUTES THE LETTER "O". APPLICANT DOES NOT CLAIM WHITE AS A FEATURE OF THE MARK. ANY WHITE REPRESENTED IN THE DRAWING IS ONLY BACKGROUND.

THE WORDING "DYESOL" HAS NO MEANING IN A FOREIGN LANGUAGE.

FOR BATTERIES INCLUDING SOLAR BATTERIES; BATTERY CHARGERS; SOLAR POWERED BATTERY CHARGERS; APPARATUS FOR CONVERTING SOLAR AND ELECTRONIC RADIATION TO ELECTRICAL ENERGY, NAMELY, PHOTOVOLTAIC SOLAR MODULES, SOLAR PANELS FOR PRODUCTION OF ELECTRICITY, PHOTOVOLTAIC THERMAL MODULES; PHOTOELECTRIC CELLS; PHOTOVOLTAIC CELLS AND ARRAYS THEREOF; FOLDABLE PHOTOELECTRIC SOLAR ARRAYS FOR USE IN OR APPLICATION TO BUILDING AND CONSTRUCTION MATERIALS; SOLAR ARRAYS FOR AUTOMOTIVE USE; PORTABLE PHOTOELECTRIC SOLAR ARRAYS, PHOTOELECTRIC SOLAR ARRAYS FOR MILITARY USE; INDOOR SOLAR DEVICES, PRODUCTS AND ARRAYS, NAMELY, SOLAR CELLS, SOLAR BATTERIES, SOLAR WAFERS, INCLUDING SUCH DEVICES WITH SENSORS AND TRANSMITTERS; SOLAR DEVICES, NAMELY, ELECTRONIC EQUIPMENT AND APPARATUS FOR PHOTOCATALYSIS AND GLAZING CONTROL; INVERTERS AND OTHER COMPONENTS, NAMELY, REGULATORS, SOLAR PUMPS AND DC PUMPS FOR USE IN SOLAR CELL SYSTEMS (U.S. CLS. 21, 23, 26, 36 AND 38).

WENDY JUN, EXAMINING ATTORNEY

SN 79-096,224. TESA S.A., SWITZERLAND, FILED 3-22-2011.

TESA SWISSCAL

THE MARK CONSISTS OF STANDARD CHARACTERS WITHOUT CLAIM TO ANY PARTICULAR FONT, STYLE, SIZE, OR COLOR.

PRIORITY DATE OF 10-15-2010 IS CLAIMED.

OWNER OF INTERNATIONAL REGISTRATION 1074062
DATED 3-22-2011, EXPIRES 3-22-2021.

OWNER OF U.S. REG. NOS. 622,195, 3,793,197 AND OTHERS.

FOR MEASURING APPARATUS AND INSTRUMENTS, NAMELY, CALIPERS, CALIBRATING RINGS, BALANCES, CLINOMETERS, COMPARATORS, COMPASSES, COUNTERS, NAMELY, KILOMETRIC COUNTERS, DISTANCE COUNTERS, NAMELY, ODOMETERS, PARTICLE COUNTERS, DETECTORS, NAMELY, POSITION DETECTORS, MOVEMENT DETECTORS, ACCELERATION DETECTORS, VIBRATION DETECTORS, TEMPERATURE DETECTORS, DISTANCE MEASURING APPARATUS, MICROSCOPIC DIFFRACTION APPARATUS, DISTANCE RECORDING APPARATUS, NAMELY, DISTANCE MEASURING APPARATUS INCORPORATING A DISTANCE RECORDING DEVICE, DYNAMOMETERS, INSTRUMENTS CONTAINING EYEPIECES, NAMELY, MICROSCOPES, BINOCULARS, OPTIC FILTERS, GAUGES, NAMELY, DIMENSION GAUGES, NAMELY, INSTRUMENTS FOR DETECTING AND MEASURING TWO-DIMENSIONAL DISTRIBUTION OF FORCE AND PRESSURE, SURFACE GAUGES, LEVEL

CLASS 9—(Continued).

GAUGES, OPTICAL GAUGES, AIR PRESSURE GAUGES, FREQUENCY METERS, HYDROMETERS, HYGROMETERS, INCLINOMETERS, ELECTRICITY INDICATORS, SPEED INDICATORS, INTEGRATED CIRCUITS, INTERFACE FOR COMPUTERS, LEVELS, NAMELY, LEVEL INDICATORS, MANOMETERS, MAGNETIC ENCODERS, METERS, NAMELY, FLOW METERS, VOLUME METERS, DISTANCE METERS, DISPLACEMENT METERS, POSITION METERS, ACCELERATION METERS, SPEED METERS, PRESSURE METERS, FORCE METERS, ELECTRONIC METERS, ELECTRIC METERS, RADIATION METERS, RADIO WAVE METERS, OPTICAL DIMENSION METERS, MICROMETERS GAUGES, MICROMETER SCREW FOR OPTICAL INSTRUMENTS, MICROMETERS, MICROSCOPE, OPTICS MIRRORS, PLANIMETERS, PRECISION DIMENSION MEASURING APPARATUS USED IN METROLOGY, NAMELY, CALIPERS, MICROMETERS, MICROSCOPES, COORDINATE MEASURING MACHINES, TELESCOPIC MEASURING ARMS, OPTICAL MEASURING INSTRUMENTS, NAMELY, INSTRUMENTS FOR MEASURING OF DIMENSIONS BY SHADOW PROJECTION, BY SURFACE INSPECTION, BY SCREENING, BY SHAPES RECOGNITION, BY FOCUSING, BY SPECIAL LIGHTING AND/OR BY ELECTRONIC TRANSMISSION MICROSCOPY, PRESSURE GAUGES, PRESSURE INDICATORS, PRESSURE MEASURING APPARATUS, NAMELY, PRESSURE MEASURING INSTRUMENTS FOR AIR GAUGES, PRESSURE DISTANCE METERS FOR AIR PROBES, PROBES FOR SCIENTIFIC PURPOSES, NAMELY, TOUCH PROBES, CONTACT PROBES, OPTICAL PROBES, ULTRASONIC PROBES, CAPACITIVE PROBES, INDUCTIVE PROBES, PIEZOELECTRIC PROBES, AIR PROBES, VIBRATING PROBES, TEMPERATURE PROBES, PROJECTION APPARATUS, NAMELY, SURFACE ROUGHNESS INSPECTION APPARATUS, APPARATUS FOR RECORDING DISTANCE, NAMELY, DISTANCE MEASURING APPARATUS, REMOTE CONTROL APPARATUS, FOR CONTROLLING MEASURING APPARATUS, SCALES, LEVER SCALES, RULERS, NAMELY, SLIDE RULES, RIGID MEASURING RULES, FLEXIBLE MEASURING RULES, SCREW-TAPPING GAUGES, NAMELY, GAUGES FOR MEASURING SCREW-TAPPING, INSIDE MICROMETERS, SLIDE CALIPERS, SLIDE-RULES, SLOPE INDICATORS, SPEED INDICATORS, TEMPERATURE INDICATORS, THERMOMETERS FOR NON MEDICAL PURPOSES; TRANSMITTERS OF ELECTRONIC SIGNALS, VERNIERS; ALL OF THE AFORESAID GOODS OF SWISS ORIGIN; ALL OF THE AFORESAID GOODS NOT IN CONNECTION WITH THE FIELD OF IRONMONGERY (U.S. CLS. 21, 23, 26, 36 AND 38).

CHARLOTTE CORWIN, EXAMINING ATTORNEY

SN 79-096,307. TESA S.A., SWITZERLAND, FILED 3-22-2011.

TESA SWISSTAST

THE MARK CONSISTS OF STANDARD CHARACTERS WITHOUT CLAIM TO ANY PARTICULAR FONT, STYLE, SIZE, OR COLOR.

PRIORITY DATE OF 10-15-2010 IS CLAIMED.

OWNER OF INTERNATIONAL REGISTRATION 1074233
DATED 3-22-2011, EXPIRES 3-22-2021.

OWNER OF U.S. REG. NOS. 622,195, 3,793,197 AND OTHERS.

FOR MEASURING APPARATUS AND INSTRUMENTS, NAMELY, CALIPERS, CALIBRATING RINGS, BALANCES, CLINOMETERS, COMPARATORS, COMPASSES, COUNTERS, NAMELY, KILOMETRIC COUNTERS, DISTANCE COUNTERS, NAMELY, ODOMETERS, PARTICLE COUNTERS, DETECTORS, NAMELY, POSITION DETECTORS, MOVEMENT DETECTORS, ACCELERATION DETECTORS, VIBRATION DETECTORS, TEMPERATURE DETECTORS, DISTANCE MEASURING APPARATUS, MICROSCOPIC DIFFRACTION APPARATUS, DISTANCE RECORDING APPARATUS, NAMELY, DISTANCE MEASURING APPARATUS INCORPORATING A DISTANCE RECORDING DEVICE, DYNAMOMETERS, INSTRUMENTS CONTAINING EYEPIECES, NAMELY, MICROSCOPES, BINOCULARS, OPTIC FIL-

CLASS 9—(Continued).

TERS, GAUGES, NAMELY, DIMENSION GAUGES, NAMELY, INSTRUMENTS FOR DETECTING AND MEASURING TWO-DIMENSIONAL DISTRIBUTION OF FORCE AND PRESSURE, SURFACE GAUGES, LEVEL GAUGES, OPTICAL GAUGES, AIR PRESSURE GAUGES, FREQUENCY METERS, HYDROMETERS, HYGROMETERS, INCLINOMETERS, ELECTRICITY INDICATORS, SPEED INDICATORS, INTEGRATED CIRCUITS, INTERFACE FOR COMPUTERS, LEVELS, NAMELY, LEVEL INDICATORS, MANOMETERS, MAGNETIC ENCODERS, METERS, NAMELY, FLOW METERS, VOLUME METERS, DISTANCE METERS, DISPLACEMENT METERS, POSITION METERS, ACCELERATION METERS, SPEED METERS, PRESSURE METERS, FORCE METERS, ELECTRONIC METERS, ELECTRIC METERS, RADIATION METERS, RADIO WAVE METERS, OPTICAL DIMENSION METERS, MICROMETERS GAUGES, MICROMETER SCREW FOR OPTICAL INSTRUMENTS, MICROMETERS, MICROSCOPE, OPTICS MIRRORS, PLANIMETERS, PRECISION DIMENSION MEASURING APPARATUS USED IN METROLOGY, NAMELY, CALIPERS, MICROMETERS, MICROSCOPES, COORDINATE MEASURING MACHINES, TELESCOPIC MEASURING ARMS, OPTICAL MEASURING INSTRUMENTS, NAMELY, INSTRUMENTS FOR MEASURING OF DIMENSIONS BY SHADOW PROJECTION, BY SURFACE INSPECTION, BY SCREENING, BY SHAPES RECOGNITION, BY FOCUSING, BY SPECIAL LIGHTING AND/OR BY ELECTRONIC TRANSMISSION MICROSCOPY, PRESSURE GAUGES, PRESSURE INDICATORS, PRESSURE MEASURING APPARATUS, NAMELY, PRESSURE MEASURING INSTRUMENTS FOR AIR GAUGES, PRESSURE DISTANCE METERS FOR AIR PROBES, PROBES FOR SCIENTIFIC PURPOSES, NAMELY, TOUCH PROBES, CONTACT PROBES, OPTICAL PROBES, ULTRASONIC PROBES, CAPACITIVE PROBES, INDUCTIVE PROBES, PIEZOELECTRIC PROBES, AIR PROBES, VIBRATING PROBES, TEMPERATURE PROBES, PROJECTION APPARATUS, NAMELY, SURFACE ROUGHNESS INSPECTION APPARATUS, APPARATUS FOR RECORDING DISTANCE, NAMELY, DISTANCE MEASURING APPARATUS, REMOTE CONTROL APPARATUS, FOR CONTROLLING MEASURING APPARATUS, SCALES, LEVER SCALES, RULERS, NAMELY, SLIDE RULES, RIGID MEASURING RULES, FLEXIBLE MEASURING RULES, SCREW-TAPING GAUGES, NAMELY, GAUGES FOR MEASURING SCREW-TAPPING, INSIDE MICROMETERS, SLIDE CALIPERS, SLIDE-RULES, SLOPE INDICATORS, SPEED INDICATORS, TEMPERATURE INDICATORS, THERMOMETERS FOR NON MEDICAL PURPOSES; TRANSMITTERS OF ELECTRONIC SIGNALS, VERNIERS; ALL OF THE AFORESAID GOODS OF SWISS ORIGIN; ALL OF THE AFORESAID GOODS NOT IN CONNECTION WITH THE FIELD OF IRONMONGERY (U.S. CLS. 21, 23, 26, 36 AND 38).

CHARLOTTE CORWIN, EXAMINING ATTORNEY

SN 79-096,697, LICHT-CON GMBH, FED REP GERMANY, FILED 4-7-2011.

LCS Solarstrom

THE MARK CONSISTS OF STANDARD CHARACTERS WITHOUT CLAIM TO ANY PARTICULAR FONT, STYLE, SIZE, OR COLOR.

PRIORITY DATE OF 11-9-2010 IS CLAIMED.

OWNER OF INTERNATIONAL REGISTRATION 1075205 DATED 4-7-2011, EXPIRES 4-7-2021.

FOR SOLAR CELLS; SOLAR ENERGY COLLECTORS FOR ELECTRICITY GENERATION; PHOTOVOLTAIC MODULES; INVERTERS (U.S. CLS. 21, 23, 26, 36 AND 38).

JULIE VEPPUMTHARA, EXAMINING ATTORNEY

CLASS 9—(Continued).

SN 79-097,565, LG INNOTEK CO., LTD., REPUBLIC OF KOREA, FILED 12-2-2010.

Met a Tune

THE MARK CONSISTS OF STANDARD CHARACTERS WITHOUT CLAIM TO ANY PARTICULAR FONT, STYLE, SIZE, OR COLOR.

PRIORITY DATE OF 6-3-2010 IS CLAIMED.

OWNER OF INTERNATIONAL REGISTRATION 1077659 DATED 12-2-2010, EXPIRES 12-2-2020.

FOR CELLULAR TELEPHONES; PORTABLE COMMUNICATION APPARATUS, NAMELY, TELEPHONE HANDSETS, HEADSETS FOR MOBILE PHONES, WALKIE-TALKIES, SATELLITE TELEPHONES, PERSONAL DIGITAL ASSISTANTS; PAGING APPARATUS; MARITIME PATROL RADAR; ELECTRIC NAVIGATIONAL INSTRUMENTS; AERONAUTICAL RADIO COMMUNICATION MACHINES AND APPARATUS; COMMUNICATIONS APPARATUS FOR AIRCRAFT, NAMELY, COMPUTERS FOR MANAGING CONTROL DEVICES FOR AIRCRAFT; PICKUPS FOR TELECOMMUNICATION APPARATUS; CAR AERIALS; AUTOMATIC TELEPHONE EXCHANGES; AUTOMATIC TELEGRAPH APPARATUS; AUTOMATIC ANSWERING MACHINES; AUTOMATIC SWITCHING APPARATUS FOR TELECOMMUNICATION; MAGNETIC HEAD CLEANERS; MAGNETIC TAPE CLEANERS; INTERPHONES; INTERCOMS; SATELLITE NAVIGATION EQUIPMENT, NAMELY, GPS NAVIGATION DEVICE, SATELLITE NAVIGATION APPARATUS FOR VEHICLES; SATELLITE DISHES FOR SATELLITE TRANSMISSIONS; EARPHONES; DEVICES FOR HANDS-FREE USE OF MOBILE PHONES; KEYBOARDS FOR MOBILE PHONES; CASES FOR MOBILE PHONES; MOBILE TELEPHONES; APPARATUS FOR WIRELESS TRANSMISSION OF ACOUSTIC INFORMATION; PERSONAL HEADPHONES FOR USE WITH SOUND TRANSMITTING SYSTEMS; VOICE FREQUENCY TRANSMISSION MACHINES AND APPARATUS, NAMELY, AUDIO-FREQUENCY TRANSFORMERS, FREQUENCY CONVERTERS; SATELLITE NAVIGATIONAL APPARATUS, NAMELY, GPS NAVIGATION DEVICE, SATELLITE NAVIGATION APPARATUS FOR VEHICLES; SATELLITE AERIALS; TELERUPTERS; REMOTE CONTROL TELEMETERING MACHINES AND APPARATUS; REMOTE CONTROL APPARATUS, NAMELY, REMOTE CONTROLS FOR RADIOS, TELEVISIONS AND STEREOS; WALKIE-TALKIES; UNPROCESSED AUDIO-VIDEO COMPACT DISC, NAMELY, BLANK AUDIO-VIDEO COMPACT DISC; AUDIOVISUAL RECEIVERS; ELECTRIC CURRENT ADAPTORS; FREQUENCY CONVERTER FOR ACTUATORS; FILTERS FOR ANTENNAS; ELECTRO-DYNAMIC APPARATUS FOR THE REMOTE CONTROL OF SIGNALS, NAMELY, ELECTRO-DYNAMIC REMOTE SIGNAL CONTROLLERS; PARABOLIC ANTENNAS; RADIO PAGERS; MOBILE TELEPHONE APPARATUS WITH BUILT-IN FACSIMILE SYSTEMS; FACSIMILE TRANSMISSION MACHINES; FACSIMILE-TRANSMITTING AND RECEIVING APPARATUS; FACSIMILE MACHINES; SPEAKING TUBES, NAMELY, MEGAPHONES, MICROPHONES; MICROPHONES FOR TELECOMMUNICATION APPARATUS; APPARATUS FOR TRANSMISSION OF COMMUNICATION; TELECOMMUNICATIONS TRANSMITTERS; TELECOMMUNICATION EXCHANGERS; ELECTRIC CAPACITORS FOR TELECOMMUNICATION APPARATUS; ELECTRIC RESISTORS FOR TELECOMMUNICATION APPARATUS; TELEPRINTERS; TELETYPEWRITERS; TELEPROMPTERS FOR TELEVISION; TELEVISION TRANSMITTERS; CABLE BROADCAST TRANSMISSION MACHINES AND APPARATUS; ELECTRO-DYNAMIC APPARATUS FOR THE REMOTE CONTROL OF RAILWAY POINTS, NAMELY, ELECTRO-DYNAMIC RAILWAY POINT REMOTE CONTROLLERS; COMMUNICATIONS APPARATUS FOR VEHICLES, NAMELY, MOBILE PHONES; CAR ANTENNAS; RADAR RECEIVERS WITH AMPLIFIERS; AMPLIFIERS; ELECTRIC TRANSIT SWITCHES; FREQUENCY CONVERTERS; CONVERTERS; TELEPHONE APPARATUS; ANSWERING MACHINES; TELEPHONE ANSWERING APPARATUS; TELEPHONE TRANSMITTERS; TELE-

CLASS 9—(Continued).

PHONE TERMINALS; TELEPHONE RECORDERS; HEADSETS FOR TELEPHONES; HANDS FREE KITS FOR PHONES; CASES FOR TELEPHONES; TELEPHONE CONNECTORS; TELEPHONES; TELEGRAPHS APPARATUS, NAMELY, AUTOMATIC TELEGRAPH APPARATUS; POWER-LINE TRANSMISSION MACHINES AND APPARATUS; TRANSMITTING SETS FOR TELECOMMUNICATION CONSISTING PRIMARILY OF APPARATUS FOR TRANSMITTING AND REPRODUCING SOUND OR IMAGES, RADIO TRANSMITTERS AND TELECOMMUNICATIONS TRANSMITTERS; TRANSMITTERS FOR TELECOMMUNICATION; TELECOMMUNICATION MACHINES AND IMPLEMENTS, NAMELY, ELECTRIC CAPACITORS, TELECOMMUNICATION CABLES, TELECOMMUNICATION SWITCHES; HOLDERS FOR ELECTRIC COILS; ELECTRIC COILS; PUBLIC TELEPHONES; ELECTRIC INSTALLATIONS FOR THE REMOTE CONTROL OF INDUSTRIAL OPERATIONS; HIGH-FREQUENCY APPARATUS, NAMELY, HIGH-FREQUENCY SWITCHING POWER SUPPLIES; SINGLE-CHANNEL RADIO COMMUNICATION MACHINES AND APPARATUS FOR FIXED STATIONS; FIXED SINGLE CHANNEL COMMUNICATION APPARATUS, NAMELY, SINGLE CHANNEL APPARATUS FOR TRANSMISSION OF COMMUNICATION; FIXED MULTICHANNEL COMMUNICATION APPARATUS, NAMELY, MULTICHANNEL CHANNEL APPARATUS FOR TRANSMISSION OF COMMUNICATION; ELECTRONIC FREQUENCY CONVERTERS FOR HIGH VELOCITY ELECTRO MOTORS; INTERFACES FOR DETECTORS; SMOKE DETECTORS; FIRE DETECTORS; MANUAL TELEGRAPH APPARATUS; MANUAL SWITCHING APPARATUS FOR TELECOMMUNICATION, NAMELY, TELECOMMUNICATION SWITCHES; COMMUNICATIONS APPARATUS FOR SHIPS, NAMELY, ELECTRIC NAVIGATIONAL INSTRUMENTS FOR SHIPS, SHIP RADIOS; INTERCOMMUNICATION APPARATUS, NAMELY, COMMUNICATIONS COMPUTERS, COMMUNICATION HUBS; PHOTOTELEGRAPHY APPARATUS; EMERGENCY SIGNAL TRANSMITTERS; VIDEO TELEPHONES; VIDEO TRANSMISSION APPARATUS; VIDEO MULTIPLEXERS; PROTECTORS FOR TELECOMMUNICATION APPARATUS, NAMELY, CASES FOR TELEPHONES, COVERS FOR TELEPHONE RECEIVERS NOT MADE OF PAPER; ELECTRICAL TRANSFORMERS FOR TELECOMMUNICATION APPARATUS; DIRECTION FINDERS, NAMELY, ELECTRONIC NAVIGATIONAL AND POSITIONING APPARATUS AND INSTRUMENTS; GALENA CRYSTALS DETECTORS FOR USE IN ELECTRONICS; VIDEO CAMERAS FOR BROADCASTING; CARRIER FREQUENCY REPEATERS FOR USE AS COMPUTER HARDWARE AND FOR RADIO AND TELEVISION STATIONS; ANTENNAS FOR WIRELESS COMMUNICATIONS APPARATUS; TERMINALS FOR RADIOTELEPHONES; RADIOTELEPHONY SETS; RADIOTELEGRAPHY SETS; MASTS FOR WIRELESS AERIALS, NAMELY, ANTENNAS; MODEMS; MICROPHONES; MICROWAVE ANTENNAS; APPARATUS FOR TRANSMITTING RADIO PROGRAMMES AND RADIO RELAY MESSAGES; RADIO TRANSMITTERS; RADIO AND TELEVISION AERIALS; REPEATERS FOR RADIO AND TELEVISION STATIONS; DIALS FOR TELECOMMUNICATION EQUIPMENT, NAMELY, TELECOMMUNICATION SWITCHES; CLEANING APPARATUS FOR SOUND RECORDING DISCS, NAMELY, MAGNETIC HEAD CLEANERS, AUDIO HEAD CLEANERS; OPEN-WIRE TRANSMISSION MACHINES AND APPARATUS; PORTABLE TELEPHONES; NAVIGATION APPARATUS FOR VEHICLES IN THE NATURE OF ON-BOARD COMPUTERS; RADAR APPARATUS, NAMELY, RADAR, RADAR DETECTORS AND RADAR GUNS FOR POLICE WORK (U.S. CLS. 21, 23, 26, 36 AND 38).

TINA BROWN, EXAMINING ATTORNEY

CLASS 9—(Continued).

SN 79-098,188. ATRIL LANGUAGE ENGINEERING, S.L., SPAIN, FILED 4-13-2011.



OWNER OF INTERNATIONAL REGISTRATION 1079472 DATED 4-13-2011, EXPIRES 4-13-2021.

THE MARK CONSISTS OF THE WORDING "DÉJÀVU" ABOVE A HORIZONTAL LINE. TWO DIAGONAL LINES APPEAR BOTH ABOVE AND BELOW THE HORIZONTAL LINE.

FOR COMPUTER PROGRAMS, NAMELY, A COMPUTER AIDED TRANSLATION TOOL FOR TRANSLATING TEXT WRITTEN IN ONE LANGUAGE INTO ANOTHER LANGUAGE (U.S. CLS. 21, 23, 26, 36 AND 38).

SHANNON TWOHIG, EXAMINING ATTORNEY

SN 79-098,398. SHANGHAI AIRIC CABLE ACCESSORIES CO., LTD, CHINA, FILED 6-6-2011.



OWNER OF INTERNATIONAL REGISTRATION 1079980 DATED 6-6-2011, EXPIRES 6-6-2021.

THE MARK CONSISTS OF THE WORD "AIRIC" WITH THE "C" MADE UP OF THREE CONCENTRIC INCOMPLETE CIRCLES.

THE WORDING "AIRIC" IN THE MARK HAS NO MEANING IN THE FOREIGN LANGUAGE AND CANNOT BE TRANSLATED.

FOR JUNCTION SLEEVES FOR ELECTRIC CABLES; TERMINALS, NAMELY, ELECTRICAL TERMINAL BLOCKS, COMPUTER TERMINALS; CABLE ARMOURING, NAMELY, DUCTING FOR ELECTRICAL CABLES, MINERAL INSULATED ELECTRICAL CABLES; ELECTRICAL SWITCHES; CONNECTIONS FOR ELECTRIC LINES; ELECTRIC CONNECTIONS; WIRE CONNECTORS, NAMELY, CONNECTION CABLES, CONNECTIONS FOR ELECTRIC LINES, CABLE CONNECTORS; ELECTRIC CONTACTS; ELECTRIC PLUGS; ADAPTER PLUGS; SAFETY CONTACT PLUGS; ELECTRIC SOCKETS; ELECTRICAL SOCKETS; MOVEABLE SOCKETS; AND OTHER CONTACTS, NAMELY, CABLE CONNECTORS, CONNECTIONS FOR ELECTRIC LINES (U.S. CLS. 21, 23, 26, 36 AND 38).

MAYUR VAGHANI, EXAMINING ATTORNEY

CLASS 9—(Continued).

SN 79-099,547. OY MAPVISION LTD, FINLAND, FILED 3-4-2011.

QUALITY GATE

THE MARK CONSISTS OF STANDARD CHARACTERS WITHOUT CLAIM TO ANY PARTICULAR FONT, STYLE, SIZE, OR COLOR.

PRIORITY DATE OF 3-2-2011 IS CLAIMED.

OWNER OF INTERNATIONAL REGISTRATION 1083045 DATED 3-4-2011, EXPIRES 3-4-2021.

FOR OPTICAL MEASURING INSTRUMENTS, OPTICAL CONTROLLERS, OPTICAL READERS AND CAMERAS AND RELATED COMPUTER PROGRAMS AND IMAGE PROCESSING PROGRAMS APPLYING MACHINE VISION SYSTEMS FOR THREE-DIMENSIONAL STUDYING OF COMBINED COMPONENTS AND ASSEMBLIES USED IN THE MANUFACTURE OF AUTOMOBILE, AVIATION, MOTORCYCLE, CROSS-COUNTRY VEHICLE, SNOWMOBILE, CONSUMER PRODUCTS AND ELECTRONIC COMPONENTS (U.S. CLS. 21, 23, 26, 36 AND 38).

RICHARD WHITE, EXAMINING ATTORNEY

CLASS 9—(Continued).

SN 79-099,870. B&C SPEAKERS S.P.A., ITALY, FILED 5-12-2011.



PRIORITY DATE OF 3-22-2011 IS CLAIMED. OWNER OF INTERNATIONAL REGISTRATION 1083802 DATED 5-12-2011, EXPIRES 5-12-2021.

NO CLAIM IS MADE TO THE EXCLUSIVE RIGHT TO USE "SONORA", APART FROM THE MARK AS SHOWN.

THE MARK CONSISTS OF A RECTANGULAR DEVICE PLACED ON THE LEFT SIDE OF THE SIGN, WITHIN WHICH THE WORDS "ARCHITETTURA" AND "SONORA", WRITTEN IN CAPITAL LETTERS, ARE DISPLAYED ON THREE LEVELS; ON THE RIGHT SIDE OF THE RECTANGULAR DEVICE THERE IS A ROUND SHAPE DEVICE CONSTITUTED BY CONCENTRIC CIRCLES.

THE ENGLISH TRANSLATION OF THE WORDS "ARCHITETTURA SONORA" IN THE MARK IS SOUND ARCHITECTURE.

FOR LOUDSPEAKERS, LOUDSPEAKER COMPONENTS, TRANSDUCERS FOR LOUDSPEAKERS, HEADPHONES, COMPRESSION DRIVERS, HORNS FOR LOUDSPEAKERS, WOOFERS, SUBWOOFERS, TWEETERS (U.S. CLS. 21, 23, 26, 36 AND 38).

INGA ERVIN, EXAMINING ATTORNEY

SN 79-099,620. AC RYAN HOLDING BV, NETHERLANDS, FILED 2-16-2011.

AC RYAN

THE MARK CONSISTS OF STANDARD CHARACTERS WITHOUT CLAIM TO ANY PARTICULAR FONT, STYLE, SIZE, OR COLOR.

PRIORITY DATE OF 10-22-2010 IS CLAIMED.

OWNER OF INTERNATIONAL REGISTRATION 1083237 DATED 2-16-2011, EXPIRES 2-16-2021.

THE NAME(S), PORTRAIT(S), AND/OR SIGNATURE(S) SHOWN IN THE MARK DOES NOT IDENTIFY A PARTICULAR LIVING INDIVIDUAL.

FOR MEDIA PLAYERS AND DIGITAL MEDIA HUBS FOR USE WITH DVDS AND HIGH DEFINITION DIGITAL MEDIA; HIGH DEFINITION AND STANDARD DEFINITION DIGITAL MEDIA STREAMING DEVICES FOR STREAMING VIDEO AND AUDIO CONTENT; APPARATUS FOR RECORDING AND REPLAYING OF SOUND, IMAGES OR DATA (U.S. CLS. 21, 23, 26, 36 AND 38).

ALLISON SCHRODY, EXAMINING ATTORNEY

SN 79-100,270. DCWATT POWER CO.,LTD., CHINA, FILED 7-5-2011.



OWNER OF INTERNATIONAL REGISTRATION 1084822 DATED 7-5-2011, EXPIRES 7-5-2021.

NO CLAIM IS MADE TO THE EXCLUSIVE RIGHT TO USE "DC WATT", APART FROM THE MARK AS SHOWN.

THE MARK CONSISTS OF THE WORDING "DC WATT" THROUGH THE MIDDLE OF A CIRCLE WITH A REPRESENTATION OF THE SUN IN THE UPPER CORNER.

FOR SOLAR BATTERIES; INTEGRATED CIRCUITS; ELECTRIC CONDUCTORS; ELECTRIC LIGHT SWITCHES; ELECTRIC CONNECTIONS; POWER INVERTERS; ELECTRICAL DISTRIBUTION BOXES; ELECTRIC CONTROL PANELS; CENTRAL PROCESSING UNITS FOR PROCESSING INFORMATION, DATA, SOUND OR IMAGES; ELECTRONIC CARD READERS (U.S. CLS. 21, 23, 26, 36 AND 38).

APRIL ROACH, EXAMINING ATTORNEY

CLASS 9—(Continued).

SN 79-102,797. DEVOLO AG, FED REP GERMANY, FILED 8-5-2011.

Vianect

THE MARK CONSISTS OF STANDARD CHARACTERS WITHOUT CLAIM TO ANY PARTICULAR FONT, STYLE, SIZE, OR COLOR.

PRIORITY DATE OF 2-11-2011 IS CLAIMED.

OWNER OF INTERNATIONAL REGISTRATION 1091388 DATED 8-5-2011, EXPIRES 8-5-2021.

FOR ADAPTERS, IN PARTICULAR FOR ADAPTING CONNECTORS BETWEEN ELECTRIC AND ELECTRONIC APPARATUS, INCLUDING APPARATUS FOR THE TRANSMISSION, STORAGE, RECORDING, PROCESSING AND REPRODUCTION OF IMAGES, DATA AND SOUND; ADAPTERS, IN PARTICULAR CONNECTING ELECTRIC AND ELECTRONIC APPARATUS, INCLUDING APPARATUS FOR THE TRANSMISSION, STORAGE, RECORDING, PROCESSING AND REPRODUCTION OF IMAGES, DATA AND SOUND TO VARIOUS INTERFACES IN THE NATURE OF HARDWARE COMPONENTS; ELECTRIC CABLES; ELECTRIC WIRES; ELECTRICAL WIRE; CONNECTIONS FOR ELECTRIC LINES, ELECTRIC CABLES AND ELECTRIC WIRES; APPARATUS FOR RECORDING, STORING, PROCESSING, TRANSMISSION OR REPRODUCTION OF SOUND, IMAGES AND DATA; DATA TRANSMISSION APPARATUS FOR THE WIRELESS TRANSMISSION OF DATA TO TERMINALS; RECORDED COMPUTER SOFTWARE, NAMELY, OPERATING SYSTEM PROGRAMS; COMPUTER SOFTWARE FOR TRANSMITTING, PROCESSING, MANIPULATING AND ANALYSING DATA; COMPUTER SOFTWARE FOR WIRELESS CONTENT DELIVERY; DATA COMMUNICATIONS SOFTWARE; APPARATUS, INSTRUMENTS AND MEDIA FOR THE RECORDING, REPRODUCTION, SCANNING, INPUT, STORAGE, PROCESSING, EDITING, TRANSMISSION, BROADCASTING AND RETRIEVAL OF MUSIC, SOUNDS, IMAGES, TEXT, SIGNALS, VIDEOS, SOFTWARE, INFORMATION, DATA AND CODE (U.S. CLS. 21, 23, 26, 36 AND 38).

TOBY BULLOFF, EXAMINING ATTORNEY

CLASS 9—(Continued).

SN 85-008,755. APPLE INC., CUPERTINO, CA. FILED 4-7-2010.



THE MARK CONSISTS OF A CONFIGURATION OF A COMPUTER MOUSE FEATURING A SMOOTH, SEAMLESS, CONVEX TOP AND A GENERALLY RECTANGULAR SHAPE WITH CURVED CORNERS.

SEC. 2(F).

FOR COMPUTER PERIPHERALS (U.S. CLS. 21, 23, 26, 36 AND 38).

FIRST USE 10-20-2009; IN COMMERCE 10-20-2009.

MARTHA FROMM, EXAMINING ATTORNEY

SN 85-037,047. MORIOKA, NED, DBA OWI, INC., CARSON, CA. FILED 5-12-2010.

OWI Inc

SN 79-103,638. LOMIS INTERNATIONAL PTY LTD ACN 064 836 282, AUSTRALIA, FILED 8-30-2011.

BASSBURGER

THE MARK CONSISTS OF STANDARD CHARACTERS WITHOUT CLAIM TO ANY PARTICULAR FONT, STYLE, SIZE, OR COLOR.

OWNER OF INTERNATIONAL REGISTRATION 1093487 DATED 8-30-2011, EXPIRES 8-30-2021.

FOR AUDIO SPEAKERS (U.S. CLS. 21, 23, 26, 36 AND 38).

MARY BOAGNI, EXAMINING ATTORNEY

THE MARK CONSISTS OF STANDARD CHARACTERS WITHOUT CLAIM TO ANY PARTICULAR FONT, STYLE, SIZE, OR COLOR.

NO CLAIM IS MADE TO THE EXCLUSIVE RIGHT TO USE "INC", APART FROM THE MARK AS SHOWN.

FOR AUDIO EQUIPMENT FOR VEHICLES, NAMELY, STEREOS, AUDIO SPEAKERS, AMPLIFIERS, AUDIO EQUALIZERS, SOUND EQUALIZERS AND CROSSOVERS; AUDIO SPEAKER ENCLOSURES; CONSUMER ELECTRONIC PRODUCTS, NAMELY, AUDIO AMPLIFIERS, AUDIO SPEAKERS, AUDIO RECEIVERS, ELECTRICAL AUDIO AND SPEAKER CABLES AND CONNECTORS, HOME THEATER SYSTEMS, AUDIO DECODERS, VIDEO DECODERS, SPEAKERS, POWER CONVERSION DEVICES, POWER CONVERTERS, AND POWER INVERTERS (U.S. CLS. 21, 23, 26, 36 AND 38).

FIRST USE 9-11-1979; IN COMMERCE 9-11-1979.

INGA ERVIN, EXAMINING ATTORNEY

CLASS 9—(Continued).

SN 85-037,461. SXC HEALTH SOLUTIONS, INC., LISLE, IL. FILED 5-13-2010.



OWNER OF U.S. REG. NOS. 1,731,517 AND 1,813,491.
NO CLAIM IS MADE TO THE EXCLUSIVE RIGHT TO USE "RX", APART FROM THE MARK AS SHOWN.
THE MARK CONSISTS OF THE TERM "RX CLAIM", WHERE THE "X" IS STYLIZED AS A SWOOSH MARK.
FOR COMPUTER SOFTWARE FOR USE BY PRESCRIPTION BENEFIT MANAGERS FOR FACILITATING REMOTE ACCESS TO ONLINE INFORMATION REGARDING ONLINE MEDICAL PRESCRIPTION CLAIM ADJUDICATION (U.S. CLS. 21, 23, 26, 36 AND 38).
WILLIAM ROSSMAN, EXAMINING ATTORNEY

SN 85-108,605. RUM RUNNERS, ROCKFORD, IL. FILED 8-16-2010.

Willie Talk

THE MARK CONSISTS OF STANDARD CHARACTERS WITHOUT CLAIM TO ANY PARTICULAR FONT, STYLE, SIZE, OR COLOR.

FOR DIGITAL MEDIA, NAMELY, PRE-RECORDED VIDEO CASSETTES, DIGITAL VIDEO DISCS, DIGITAL VERSATILE DISCS, DOWNLOADABLE AUDIO AND VIDEO RECORDINGS, DVDS, AND HIGH DEFINITION DIGITAL DISCS FEATURING VISUAL AND AUDIO PERFORMANCES BY A FICTIONAL CHARACTER NAMED "WILLIE TALK"; DOWNLOADABLE MOTION PICTURES AND TELEVISION SHOWS USING THE NAME "WILLIE TALK"; MOTION PICTURE FILMS USING THE NAME "WILLIE TALK"; MUSICAL VIDEO RECORDINGS (U.S. CLS. 21, 23, 26, 36 AND 38).

FIRST USE 1-1-2012; IN COMMERCE 1-1-2012.
MIDGE BUTLER, EXAMINING ATTORNEY

CLASS 9—(Continued).

SN 85-134,556. SK TELECOM CO., LTD., SEOUL, REPUBLIC OF KOREA, FILED 9-21-2010.

3D MAGIC STORY

THE MARK CONSISTS OF STANDARD CHARACTERS WITHOUT CLAIM TO ANY PARTICULAR FONT, STYLE, SIZE, OR COLOR.

NO CLAIM IS MADE TO THE EXCLUSIVE RIGHT TO USE "3D" AND "STORY", APART FROM THE MARK AS SHOWN.

FOR DVD PLAYERS; CD PLAYERS; RECORDING AND PLAYING DEVICES FOR SOUND AND IMAGE CARRIERS; AMUSEMENT APPARATUS ADAPTED FOR USE WITH TELEVISION RECEIVERS ONLY; VIRTUAL REALITY GAME SOFTWARE; BLANK OPTICAL DISCS; OPTICAL DISCS FEATURING EDUCATIONAL CONTENT FOR CHILDREN; COMPUTER PROGRAMS FOR EDITING IMAGES, SOUND AND VIDEO; VIDEO CAMERA FOR USE WITH COMPUTERS; ELECTRONIC PUBLICATIONS, NAMELY, BOOKS FEATURING EDUCATIONAL CONTENT FOR CHILDREN; AND DOWNLOADABLE ELECTRONIC PUBLICATIONS IN THE NATURE OF BOOKS IN THE FIELD OF EDUCATION, NAMELY, DOWNLOADABLE ELECTRONIC PUBLICATIONS FOR TEACHING SCIENCE, MATHEMATICS, AND SOCIAL STUDIES TO CHILDREN (U.S. CLS. 21, 23, 26, 36 AND 38).

REGINA DRUMMOND, EXAMINING ATTORNEY

SN 85-134,883. RYOKA SYSTEMS INC., TOKYO, JAPAN, FILED 9-21-2010.

CRYSTAL PROFILER

THE MARK CONSISTS OF STANDARD CHARACTERS WITHOUT CLAIM TO ANY PARTICULAR FONT, STYLE, SIZE, OR COLOR.

NO CLAIM IS MADE TO THE EXCLUSIVE RIGHT TO USE "CRYSTAL", APART FROM THE MARK AS SHOWN.

FOR COMPUTER SOFTWARE FOR USE IN ANALYSIS OF POWDER X-RAY DIFFRACTION DATA OF CHEMICAL COMPOUNDS AND, BASED ON THE AFORESAID ANALYSIS, DETERMINATION OF MOLECULAR CRYSTAL STRUCTURE OF THE CHEMICAL COMPOUNDS (U.S. CLS. 21, 23, 26, 36 AND 38).

BARNEY CHARLON, EXAMINING ATTORNEY

CLASS 9—(Continued).

SN 85-153,551. NITE IZE, INC., BOULDER, CO. FILED 10-15-2010.

PADLOK

THE MARK CONSISTS OF STANDARD CHARACTERS WITHOUT CLAIM TO ANY PARTICULAR FONT, STYLE, SIZE, OR COLOR.

FOR CARRIERS FOR PORTABLE AND HAND HELD SCIENTIFIC, ELECTRICAL, MEASURING AND SIGNALING DEVICES, NAMELY, CARRYING CASES SPECIALLY ADAPTED FOR AUDIO AND VIDEO DIGITAL MEDIA PLAYERS AND RECORDERS IN THE NATURE OF MP3 PLAYERS AND RECORDERS, FOR PORTABLE TWO WAY COMMUNICATION SYSTEMS, NAMELY, RADIOS, PAGERS AND WALKIE-TALKIES, FOR PORTABLE VIDEO GAMES SYSTEMS, CAMERAS, PORTABLE GLOBAL POSITIONING SYSTEM RECEIVERS (U.S. CLS. 21, 23, 26, 36 AND 38).

MICHAEL LITZAU, EXAMINING ATTORNEY

CLASS 9—(Continued).

SN 85-209,218. ARCHITECTURAL COMPUTER SERVICES, INC., SALT LAKE CITY, UT. FILED 1-3-2011.

ALTARIX

THE MARK CONSISTS OF STANDARD CHARACTERS WITHOUT CLAIM TO ANY PARTICULAR FONT, STYLE, SIZE, OR COLOR.

FOR COMPUTER SOFTWARE USED TO DRAFT AND CALCULATE SPECIFICATIONS FOR ARCHITECTURAL, ENGINEERING, OR CONSTRUCTION PROJECTS; COMMUNICATIONS SOFTWARE FOR CONNECTING COMPUTER NETWORK USERS WITH BUILDING INFORMATION MODELS, COST ESTIMATING DATA, PRODUCT INFORMATION AND OTHER CONSTRUCTION INFORMATION FOR ARCHITECTURAL, ENGINEERING, OR CONSTRUCTION PROJECTS; COMPUTER SOFTWARE FOR DATABASE MANAGEMENT OF PROJECTS IN THE FIELDS OF ARCHITECTURAL, ENGINEERING, OR CONSTRUCTION PROJECTS; COMPUTER APPLICATION SOFTWARE FOR MOBILE PHONES, HANDHELD COMPUTERS, TABLET PERSONAL COMPUTER AND SMART PHONES, NAMELY, SOFTWARE FOR CONNECTING COMPUTER NETWORK USERS WITH BUILDING INFORMATION MODELS, COST ESTIMATING DATA, PRODUCT INFORMATION AND OTHER CONSTRUCTION INFORMATION FOR ARCHITECTURAL, ENGINEERING, OR CONSTRUCTION PROJECTS; COMPUTER APPLICATION SOFTWARE FOR MOBILE PHONES, HANDHELD COMPUTERS, TABLET PERSONAL COMPUTERS AND SMART PHONES, NAMELY, SOFTWARE FOR DATABASE MANAGEMENT OF PROJECTS IN THE FIELDS OF ARCHITECTURAL, ENGINEERING, OR CONSTRUCTION PROJECTS; COMPUTER SOFTWARE FOR APPLICATION AND DATABASE INTEGRATION AND COMMUNICATION IN THE FIELD OF BUILDING INFORMATION MODELS, COST ESTIMATING DATA, PRODUCT INFORMATION AND OTHER CONSTRUCTION INFORMATION FOR ARCHITECTURAL, ENGINEERING, OR CONSTRUCTION PROJECTS; COMPUTER SOFTWARE FOR APPLICATION AND DATABASE INTEGRATION AND COMMUNICATION IN THE FIELD OF PROJECT MANAGEMENT AND PROJECT COLLABORATION IN ARCHITECTURAL, ENGINEERING, OR CONSTRUCTION PROJECTS; COMPUTER SOFTWARE FOR VIEWING, PRINTING, AND EDITING FILES CONTAINING BUILDING INFORMATION MODELS, COST ESTIMATING DATA, PRODUCT INFORMATION AND OTHER CONSTRUCTION INFORMATION FOR ARCHITECTURAL, ENGINEERING OR CONSTRUCTION PROJECTS (U.S. CLS. 21, 23, 26, 36 AND 38).

STEPHANIE ALI, EXAMINING ATTORNEY

SN 85-168,382. LG ELECTRONICS INC., SEOUL 150-721, REPUBLIC OF KOREA, FILED 11-3-2010.

INFINIA TV@ your taste!

THE MARK CONSISTS OF STANDARD CHARACTERS WITHOUT CLAIM TO ANY PARTICULAR FONT, STYLE, SIZE, OR COLOR.

OWNER OF REPUBLIC OF KOREA REG. NO. 009734708, DATED 6-23-2011, EXPIRES 2-14-2021.

FOR TELEVISION RECEIVERS (U.S. CLS. 21, 23, 26, 36 AND 38).

MARK T. MULLEN, EXAMINING ATTORNEY

SN 85-186,751. SONGCAST, INC, CUYAHOGA FALLS, OH. FILED 11-29-2010.

SongCast

THE MARK CONSISTS OF STANDARD CHARACTERS WITHOUT CLAIM TO ANY PARTICULAR FONT, STYLE, SIZE, OR COLOR.

FOR COMPUTER PROGRAMS FOR PROCESSING DIGITAL MUSIC FILES; COMPUTER SOFTWARE FOR THE FIELD OF WAREHOUSING AND DISTRIBUTION, TO MANAGE TRANSACTIONAL DATA, PROVIDE STATISTICAL ANALYSIS, AND PRODUCE NOTIFICATIONS AND REPORTS; DIGITAL MUSIC DOWNLOADABLE FROM THE INTERNET (U.S. CLS. 21, 23, 26, 36 AND 38).

FIRST USE 9-18-2006; IN COMMERCE 9-18-2006.
BARBARA A. GOLD, EXAMINING ATTORNEY

CLASS 9—(Continued).

SN 85-213,956. INVENSYS CONTROLS UK LTD, LONDON, UNITED KINGDOM, FILED 1-10-2011.



THE MARK CONSISTS OF THE LETTERS "E" AND "O" WITH A LEAF GROWING INTO THE CENTER OF THE "O". FOR ELECTRONIC CONTROLLERS FOR COMMERCIAL REFRIGERATION SYSTEMS; SUPERVISION AND MONITORING SYSTEM COMPRISED OF COMPUTERS AND COMPUTER SOFTWARE USED TO MONITOR, RECORD DATA, AND REMOTELY CONTROL AND MANAGE THE ALARMS OF REFRIGERATION AND AIR-CONDITIONING SYSTEMS IN COMMERCIAL APPLICATIONS SUCH AS SUPERMARKETS, CONVENIENCE STORES, STORAGE AND CATERING; WIRELESS COMMUNICATION DEVICES FOR DATA TRANSMISSION USED IN THE AFORE-MENTIONED APPLICATIONS (U.S. CLS. 21, 23, 26, 36 AND 38).
DARRYL SPRUILL, EXAMINING ATTORNEY

SN 85-217,638. HYDRO-QUEBEC, MONTREAL, QUEBEC, CANADA, FILED 1-14-2011.



PRIORITY CLAIMED UNDER SEC. 44(D) ON CANADA APPLICATION NO. 1494043, FILED 8-30-2010, REG. NO. TMA809233, DATED 10-17-2011, EXPIRES 10-17-2026.
THE MARK CONSISTS OF 2 SEMI-OPENED CUBE-SHAPED BLOCKS EACH WITH A SQUARE HOLE, ONE BLOCK ON TOP OF THE OTHER SO AS TO FORM AN "S", ALL ABOVE THE LETTERS "SIMEB" IN STYLIZED FONT.
FOR BUILDING ENERGY SIMULATION SOFTWARE, NAMELY, A SOFTWARE THAT SIMULATES ENERGY BEHAVIOR OF COMMERCIAL AND INSTITUTIONAL BUILDINGS IN ORDER TO GUIDE CLIENTS TOWARDS INTEGRATED CONCEPTS FOR BUILDINGS OR RE-COMMISSIONING AND ENERGY WISE RENOVATIONS FOR EXISTING BUILDINGS (U.S. CLS. 21, 23, 26, 36 AND 38).
BRENDAN REGAN, EXAMINING ATTORNEY

CLASS 9—(Continued).

SN 85-231,349. THE INTERNATIONAL SOCIETY OF PRIMERUS LAW FIRMS, LTD., GRAND RAPIDS, MI. FILED 2-1-2011.



OWNER OF U.S. REG. NOS. 1,718,664, 3,255,915 AND OTHERS.
THE COLOR(S) RED, BLACK, LIGHT SILVER, AND DARK SILVER IS/ARE CLAIMED AS A FEATURE OF THE MARK.
THE MARK CONSISTS OF A THREE-DIMENSIONAL STYLIZED LETTER "P" IN DARK SILVER AND LIGHT SILVER SET ON A THREE-DIMENSIONAL SQUARE BASE OF LIGHT SILVER WITH A DARK SILVER BORDER, ADJACENT TO THE STYLIZED WORD "PRIMERUS" IN DARK SILVER AND LIGHT SILVER, A RED LINE, AND THE WORDS "BUILT ON INTEGRITY", "DRIVEN BY INNOVATION." IN BLACK. THE COLOR WHITE REPRESENTS HIGHLIGHTING TO CREATE THE APPEARANCE OF LIGHTING AND IS NOT PART OF THE MARK.
FOR ELECTRONIC PUBLICATIONS, NAMELY, DOWNLOADABLE MAGAZINES IN THE FIELD OF LAW AND CONTINUING LEGAL EDUCATION; DOWNLOADABLE ELECTRONIC EDUCATIONAL MATERIALS IN THE FIELDS OF LAW AND CONTINUING LEGAL EDUCATION (U.S. CLS. 21, 23, 26, 36 AND 38).
ARETHA SOMERVILLE, EXAMINING ATTORNEY

SN 85-236,175. EFLUXOR LLC, MANASSAS, VA. FILED 2-7-2011.

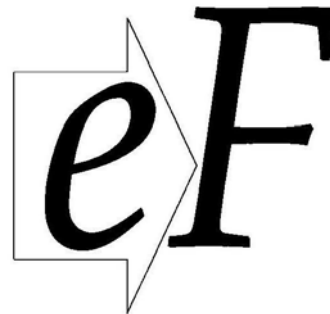

THE MARK CONSISTS OF THE ITALICIZED LETTERS "EF" APPEARING WITH THE OUTLINE OF A RIGHT-FACING ARROW ENCLOSING THE "E".
FOR ELECTROSTATIC EMISSION CONTROL DEVICES, NAMELY, APPARATUSES FOR CONDUCTING, SWITCHING, TRANSFORMING, REGULATING, AND CONTROLLING ELECTRICITY (U.S. CLS. 21, 23, 26, 36 AND 38).
WANDA KAY PRICE, EXAMINING ATTORNEY

CLASS 9—(Continued).

SN 85-250,192. US LAND TITLE LLC, FORMERLY US LAND TITLE LLC, KEY WEST, FL. FILED 2-24-2011.



NO CLAIM IS MADE TO THE EXCLUSIVE RIGHT TO USE "SEARCH VMS", APART FROM THE MARK AS SHOWN.

THE COLOR(S) BLUE, GREEN, BLACK AND WHITE IS/ARE CLAIMED AS A FEATURE OF THE MARK.

THE MARK CONSISTS OF A BLUE ARROW POINTING LEFT WITH THE WORD "NATIONS" IN WHITE. BELOW THE BLUE ARROW IS A GREEN ARROW POINTING RIGHT WITH THE WORD "SEARCH" IN BLACK. BELOW THE GREEN ARROW ARE THE LETTERS "VMS" IN BLACK.

FOR ONLINE DOWNLOADABLE COMPUTER PROGRAMMES FOR DOCUMENT MANAGEMENT; ONLINE DOWNLOADABLE COMPUTER SOFTWARE FOR THE COLLECTION, EDITING, ORGANIZING, MODIFYING, BOOK MARKING, TRANSMISSION, STORAGE AND SHARING OF DATA AND INFORMATION; COMPUTER SOFTWARE PLATFORMS FOR VENDOR MANAGEMENT (U.S. CLS. 21, 23, 26, 36 AND 38).

FIRST USE 2-1-2011; IN COMMERCE 2-1-2011.
MICHAEL WIENER, EXAMINING ATTORNEY

SN 85-265,518. BUTERA, CONNIE, PHOENIX, AZ. FILED 3-12-2011.

Just You & Me Kid

THE MARK CONSISTS OF STANDARD CHARACTERS WITHOUT CLAIM TO ANY PARTICULAR FONT, STYLE, SIZE, OR COLOR.

FOR PRE-RECORDED DIGITAL VIDEO DISCS FEATURING EXERCISES AND ACTIVITIES FOR PARENTS AND CHILDREN TO DO TOGETHER (U.S. CLS. 21, 23, 26, 36 AND 38).

JULIE VEPPUMTHARA, EXAMINING ATTORNEY

CLASS 9—(Continued).

SN 85-274,327. MASCOTTE HOLDINGS, INC., NEW YORK, NY. FILED 3-23-2011.

YEEZI

THE MARK CONSISTS OF STANDARD CHARACTERS WITHOUT CLAIM TO ANY PARTICULAR FONT, STYLE, SIZE, OR COLOR.

THE NAME SHOWN IN THE MARK IDENTIFIES KANYE WEST A LIVING INDIVIDUAL, WHOSE CONSENT TO REGISTER IS MADE OF RECORD.

FOR MUSICAL SOUND RECORDINGS; AUDIO-VISUAL RECORDINGS, NAMELY, COMPACT DISCS, TAPE CASSETTES, AUDIO CASSETTES, AUDIO TAPES, AUDIO DISCS, PHONOGRAPH RECORDS, CD-ROMS, VIDEO TAPES, VIDEO CASSETTES, VIDEO DISCS, DVDS, DIGITAL AUDIO TAPES (DATS), DOWNLOADABLE MP3 FILES, AND LASER DISCS, ALL FEATURING MUSIC AND SOUND TRACKS; DOWNLOADABLE MUSICAL SOUND RECORDINGS; DOWNLOADABLE VIDEO RECORDINGS FEATURING MUSIC; DOWNLOADABLE ELECTRONIC PUBLICATIONS IN THE NATURE OF BOOKS, BOOKLETS, MAGAZINES, JOURNALS, MANUALS, BROCHURES, LEAFLETS, PAMPHLETS AND NEWSLETTERS, ALL IN THE FIELD OF MUSIC, ENTERTAINMENT, TELEVISION, FILM, THE ARTS, FASHION, LIFESTYLES, CULTURE, SOCIAL ISSUES AND POLITICS; ELECTRONIC PUBLICATIONS, NAMELY, BOOKS, BOOKLETS, MAGAZINES, JOURNALS, MANUALS, BROCHURES, LEAFLETS, PAMPHLETS AND NEWSLETTERS, ALL IN THE FIELD OF MUSIC, ENTERTAINMENT, TELEVISION, FILM, THE ARTS, FASHION, LIFESTYLES, CULTURE, SOCIAL ISSUES AND POLITICS, RECORDED ON CD-ROMS, DISKETTES, FLOPPY DISKS, VIDEO CASSETTES, AND MAGNETIC TAPES; MAGNETS; DECORATIVE MAGNETS; REFRIGERATOR MAGNETS; NOVELTY MAGNETS; MOUSE PADS; COMPACT DISC CASES AND COVERS; FACE PLATES IN THE NATURE OF COVERS FOR CELL PHONES; JACKETS FOR VIDEO CASSETTES, TAPES AND DISCS; FITTED CASES FOR STORAGE AND TRANSPORTATION, NAMELY, CASES FOR COMPACT DISCS, AUDIO CASSETTES, VIDEO CASSETTES, CD-ROMS, COMPUTERS, CAMERAS, CAMCORDERS AND PORTABLE PHONES; COMPUTER CARRYING CASES; WRIST RESTS AND SUPPORTS FOR COMPUTER MOUSE USERS; WRIST RESTS FOR USE WITH COMPUTERS AND COMPUTER ACCESSORIES; COMPUTER KEYBOARD WRIST PADS; PROTECTIVE EYEWEAR; EYEGLASSES AND EYEGLASS FRAMES; SUNGLASSES AND SUNGLASS FRAMES; CLIP-ON SUNGLASSES; SPECTACLES AND SPECTACLE FRAMES; LENSES FOR EYEGLASSES, SUNGLASSES AND SPECTACLES; EYEGLASS, SUNGLASS AND SPECTACLE CASES; EYEWEAR ACCESSORIES, NAMELY, EYEGLASS, SUNGLASS AND SPECTACLE STRAPS WHICH RESTRAIN EYEWEAR FROM MOVEMENT ON A WEARER; GOGGLES FOR SPORTS; MOTORCYCLE GOGGLES AND NIGHT VISION GOGGLES; EYEGLASS, SUNGLASS AND SPECTACLE CHAINS; BINOCULARS; MAGNIFYING GLASSES; DOG, SIGNAL AND SPORT WHISTLES; DOWNLOADABLE MUSIC, RING TONES, GRAPHICS, AND ELECTRONIC GAMES VIA THE INTERNET AND WIRELESS DEVICES; DOWNLOADABLE WIRELESS COMPUTER GAME SOFTWARE VIA THE INTERNET AND WIRELESS DEVICES; DOWNLOADABLE WIRELESS ENTERTAINMENT VIA THE INTERNET AND WIRELESS DEVICES, NAMELY, RING TONES, DOWNLOADABLE COMPUTER SOFTWARE FEATURING SCREEN SAVERS, IMAGES, AND WALLPAPER; COMPUTER GAME CARTRIDGES, DISCS, CASSETTES, TAPES, JOYSTICKS, PROGRAMS AND SOFTWARE; HAND HELD JOY STICK UNITS FOR PLAYING VIDEO GAMES; VIDEO GAME CARTRIDGES, VIDEO GAME DISCS, VIDEO GAME TAPE CASSETTES, VIDEO GAME SOFTWARE, VIDEO GAME PROGRAMS, AND VIDEO GAME JOYSTICKS; INTERACTIVE MULTIMEDIA COMPUTER GAME PROGRAM; INTERACTIVE VIDEO GAME PROGRAMS; INTERAC-

CLASS 9—(Continued).

TIVE AUDIO GAME DISCS CONTAINING ACTION GAMES AND ROLE PLAYING GAMES; INTERACTIVE VIDEO GAMES OF VIRTUAL REALITY COMPRISED OF COMPUTER HARDWARE AND SOFTWARE; VIRTUAL REALITY GAME SOFTWARE; VIDEO GAME MACHINES AND VIDEO OUTPUT GAME MACHINES FOR USE WITH TELEVISIONS; MULTI-MEDIA SOFTWARE RECORDED ON CD-ROM FEATURING MUSIC, ENTERTAINMENT, AND GAMES; COMPUTER SOFTWARE FOR USE IN THE DESIGN, DEVELOPMENT AND EXECUTION OF WIRELESS GAME AND ENTERTAINMENT PROGRAMS AND APPLICATIONS (U.S. CLS. 21, 23, 26, 36 AND 38).

CHARISMA HAMPTON, EXAMINING ATTORNEY

SN 85-275,160. ZS ASSOCIATES, INC., EVANSTON, IL. FILED 3-23-2011.

APO

THE MARK CONSISTS OF STANDARD CHARACTERS WITHOUT CLAIM TO ANY PARTICULAR FONT, STYLE, SIZE, OR COLOR.

FOR SALES AND MARKETING SOFTWARE WITH A FOCUS ON ANALYTICS FOR DATABASE MANAGEMENT, PROVIDING STATISTICAL ANALYSIS AND PRODUCING REPORTS, SALES COMPENSATION MANAGEMENT, INFORMATION MANAGEMENT AND REPORTING, TERRITORY AND ACCOUNT PLANNING, MARKETING CAMPAIGN DESIGN AND MANAGEMENT, AND MANAGEMENT OF OTHER BUSINESS OPERATIONS, ALL OF THE FOREGOING FOR THE PURPOSE OF ENABLING COMPANIES TO OUTSOURCE AND IMPROVE THEIR SALES AND MARKETING OPERATIONS (U.S. CLS. 21, 23, 26, 36 AND 38).

LESLIE RICHARDS, EXAMINING ATTORNEY

SN 85-278,590. HUAWEI TECHNOLOGIES CO., LTD., SHENZHEN, CHINA, FILED 3-28-2011.

FLUENCY

THE MARK CONSISTS OF STANDARD CHARACTERS WITHOUT CLAIM TO ANY PARTICULAR FONT, STYLE, SIZE, OR COLOR.

FOR MOBILE TELEPHONES; MODEMS; USB MODEMS; WIRELESS MODEMS; COMPUTERS; DIGITAL PHOTO FRAMES FOR DISPLAYING DIGITAL PICTURES, VIDEO CLIPS AND MUSIC; TABLET COMPUTERS; DIGITAL BOOK READERS; PERSONAL DIGITAL ASSISTANTS (PDA); NETWORK ROUTERS; GATEWAY ROUTERS IN THE NATURE OF COMPUTER CONTROL HARDWARE; COMPUTER PERIPHERAL DEVICES; ELECTRONIC COMMUNICATIONS SYSTEMS COMPRISED OF COMPUTER HARDWARE AND SOFTWARE FOR THE TRANSMISSION OF DATA BETWEEN TWO POINTS (U.S. CLS. 21, 23, 26, 36 AND 38).

NAKIA HENRY, EXAMINING ATTORNEY

CLASS 9—(Continued).

SN 85-278,596. HUAWEI TECHNOLOGIES CO., LTD., SHENZHEN, CHINA, FILED 3-28-2011.

HUAWEI FLUENCY

THE MARK CONSISTS OF STANDARD CHARACTERS WITHOUT CLAIM TO ANY PARTICULAR FONT, STYLE, SIZE, OR COLOR.

OWNER OF U.S. REG. NOS. 2,750,650, 3,313,908 AND 3,854,515.

FOR MOBILE TELEPHONES; MODEMS; USB MODEMS; WIRELESS MODEMS; COMPUTERS; DIGITAL PHOTO FRAMES FOR DISPLAYING DIGITAL PICTURES, VIDEO CLIPS AND MUSIC; TABLET COMPUTERS; DIGITAL BOOK READERS; PERSONAL DIGITAL ASSISTANTS (PDA); NETWORK ROUTERS; GATEWAY ROUTERS IN THE NATURE OF COMPUTER CONTROL HARDWARE; COMPUTER PERIPHERAL DEVICES; ELECTRONIC COMMUNICATIONS SYSTEMS COMPRISED OF COMPUTER HARDWARE AND SOFTWARE FOR THE TRANSMISSION OF DATA BETWEEN TWO POINTS (U.S. CLS. 21, 23, 26, 36 AND 38).

NAKIA HENRY, EXAMINING ATTORNEY

SN 85-282,317. NOTHIN 2 LOSE RECORDS, RICHMOND, TX. FILED 3-31-2011.



NO CLAIM IS MADE TO THE EXCLUSIVE RIGHT TO USE "RECORDS", APART FROM THE MARK AS SHOWN.

THE MARK CONSISTS OF THE LARGE STYLIZED BLOCK CHARACTER TERM "N2L" WITH NEGATIVE IMAGES OF SKYLINES USED TO FILL EACH OF THE CHARACTERS WHICH RESTS ON A ROUGH LINED RECTANGLE THAT CONTAINS THE TERM "RECORDS". THE SMALL STYLIZED TERMS "NOTHIN 2 LOSE" IS SUPERIMPOSED ACROSS THE MIDDLE OF "N2L".

FOR MUSICAL SOUND RECORDINGS AND AUDIO-VISUAL RECORDINGS FEATURING PRERECORDED MUSIC AND PRERECORDED COMPACT DISCS, TAPE CASSETTES, RECORDS, CD-ROMS, VHS VIDEO TAPES, DVD, LASER DISCS FEATURING MUSIC (U.S. CLS. 21, 23, 26, 36 AND 38).

FIRST USE 11-6-2010; IN COMMERCE 11-6-2010.

ANTHONY RINKER, EXAMINING ATTORNEY

CLASS 9—(Continued).

SN 85-286,239. EMERGE CLINICAL SOLUTIONS, LLC, DALLAS, TX. FILED 4-5-2011.



OWNER OF U.S. REG. NOS. 3,731,716 AND 3,883,624.
 NO CLAIM IS MADE TO THE EXCLUSIVE RIGHT TO USE "CLINICAL DECISION SOFTWARE", APART FROM THE MARK AS SHOWN.
 THE MARK CONSISTS OF A BOX CONTAINING THE WORD "EMERGE" SPELLED WITH A STYLIZED LETTER "E". DIRECTLY UNDERNEATH THE BOX IS THE PHRASE "CLINICAL DECISION SOFTWARE". UNDERNEATH THAT ARE THE PHRASES AND PUNCTUATION "FASTER IDENTIFICATION . BETTER RESULTS . LOWER COST".
 FOR SOFTWARE FOR HELPING CLINICIANS MANAGE PATIENT CARE (U.S. CLS. 21, 23, 26, 36 AND 38).
 GINA FINK, EXAMINING ATTORNEY

SN 85-288,598. ZYGO CORPORATION, MIDDLEFIELD, CT. FILED 4-7-2011.

LIVEPHASE

THE MARK CONSISTS OF STANDARD CHARACTERS WITHOUT CLAIM TO ANY PARTICULAR FONT, STYLE, SIZE, OR COLOR.
 FOR SOFTWARE FOR DATA ACQUISITION AND DISPLAYING 3D REAL-TIME WAVEFRONT DATA FOR USE IN CONNECTION WITH INTERFEROMETERS (U.S. CLS. 21, 23, 26, 36 AND 38).
 FIRST USE 2-28-2011; IN COMMERCE 2-28-2011.
 RUSS HERMAN, EXAMINING ATTORNEY

CLASS 9—(Continued).

SN 85-288,664. CASE ENGINEERING, LLC, AKA CASE CONTROLS, EVANSVILLE, IN. FILED 4-7-2011.

AIR LOGIX

THE MARK CONSISTS OF STYLIZED LETTERS "A I R L O G I X". THE LETTERS "A" "R" AND THE "G" A NOT 100% COMPLETE WITH A VERY SMALL PORTION OF THE LETTERS MISSING.
 FOR A LADDER LOGIC SOFTWARE PROGRAM DESIGNED TO RUN ON COMMERCIALY AVAILABLE PROGRAMMABLE LOGIC CONTROLLER PLATFORMS FOR THE SPECIFIC PURPOSE OF CONTROLLING THE INLET GUIDE VANES AND BY-PASS VALVES OF A CENTRIFUGAL AIR COMPRESSOR WITH A CONTROL ALGORITHM WITH THE INTENTION OF IMPROVING TURNDOWN CAPACITY OF THE THROTTLE RANGE (U.S. CLS. 21, 23, 26, 36 AND 38).
 FIRST USE 2-9-2004; IN COMMERCE 11-10-2005.
 JOSETTE BEVERLY, EXAMINING ATTORNEY

SN 85-290,510. ONCQUE CORPORATION, TAICHUNG, TAIWAN, FILED 4-8-2011.

VBS

THE MARK CONSISTS OF STANDARD CHARACTERS WITHOUT CLAIM TO ANY PARTICULAR FONT, STYLE, SIZE, OR COLOR.
 FOR ELECTRONIC SWITCHES; ELECTRONIC SENSORS; ELECTRO-OPTICAL SENSITIVE SWITCHES; INFRARED SENSITIVE ELECTRONIC SWITCHES; ELECTRONIC VIBRATION SENSITIVE SWITCHES; ELECTRONIC PRESSURE SENSITIVE SWITCHES; ELECTRONIC PROXIMITY SENSITIVE SWITCHES; TEMPERATURE SENSITIVE SWITCHES; ELECTRONIC TRANSISTORS; ELECTRICAL AUTOMATION CONTROLLERS FOR USE IN INDUSTRIAL AUTOMATION; TOUCH SENSITIVE ELECTRONIC SWITCHES; TELECOMMUNICATION SWITCHES; TILT SENSITIVE ELECTRONIC SWITCHES (U.S. CLS. 21, 23, 26, 36 AND 38).
 FIRST USE 9-7-2010; IN COMMERCE 9-7-2010.
 JOHN WILKE, EXAMINING ATTORNEY

CLASS 9—(Continued).

SN 85-296,746. INSTINET, LLC, NEW YORK, NY. FILED 4-15-2011.

NEWPORT

THE MARK CONSISTS OF STANDARD CHARACTERS WITHOUT CLAIM TO ANY PARTICULAR FONT, STYLE, SIZE, OR COLOR.

OWNER OF U.S. REG. NO. 3,038,777.
FOR COMPUTER PROGRAMS AND COMPUTER SOFTWARE FOR ELECTRONICALLY TRADING AND ANALYZING SECURITIES AND OTHER LISTED FINANCIAL INSTRUMENTS (U.S. CLS. 21, 23, 26, 36 AND 38).

FIRST USE 12-31-2001; IN COMMERCE 12-31-2001.
RENEE MCCRAY, EXAMINING ATTORNEY

SN 85-297,591. KRUZINSKI, INC, DBA CULTURE CONSULTING, DECATUR, GA. FILED 4-18-2011.

Culture Sleuth

THE MARK CONSISTS OF STANDARD CHARACTERS WITHOUT CLAIM TO ANY PARTICULAR FONT, STYLE, SIZE, OR COLOR.

NO CLAIM IS MADE TO THE EXCLUSIVE RIGHT TO USE "CULTURE". APART FROM THE MARK AS SHOWN.

FOR DOWNLOADABLE VIDEO RECORDINGS FEATURING INFORMATION CONCERNING CHANGE MANAGEMENT AND ORGANIZATION CULTURE (U.S. CLS. 21, 23, 26, 36 AND 38).

CURTIS FRENCH, EXAMINING ATTORNEY

CLASS 9—(Continued).

SN 85-301,628. UNITEDHEALTH GROUP INCORPORATED, MINNETONKA, MN. FILED 4-21-2011.

UNITEDHEALTHCARE

THE MARK CONSISTS OF STANDARD CHARACTERS WITHOUT CLAIM TO ANY PARTICULAR FONT, STYLE, SIZE, OR COLOR.

OWNER OF U.S. REG. NOS. 1,967,622, 3,269,588 AND OTHERS.

FOR DOWNLOADABLE ELECTRONIC PUBLICATIONS, NAMELY, ARTICLES, NEWSLETTERS, BROCHURES, FORMS, REPORTS, FLYERS AND BOOKLETS IN THE FIELDS OF HEALTH AND WELLNESS, STRESS MANAGEMENT, SMOKING CESSATION, PREVENTATIVE CARE, SPECIFIC DISEASES, MENTAL HEALTH, WOMEN'S HEALTH, MEN'S HEALTH, DIET AND EXERCISE, PREGNANCY, AND HEALTHCARE REFORM; DOWNLOADABLE PODCASTS IN THE FIELD OF HEALTH AND WELLNESS; DOWNLOADABLE ELECTRONIC PUBLICATIONS, NAMELY, ARTICLES, NEWSLETTERS, BROCHURES, FORMS, REPORTS, FLYERS AND BOOKLETS, DELIVERED VIA E-MAIL IN THE FIELD OF HEALTH AND WELLNESS, HEALTH CARE (U.S. CLS. 21, 23, 26, 36 AND 38).

AMY HELLA, EXAMINING ATTORNEY

SN 85-301,629. LEHMAN BROTHERS HOLDINGS INC., NEW YORK, NY. FILED 4-21-2011.

SETAI

THE MARK CONSISTS OF STANDARD CHARACTERS WITHOUT CLAIM TO ANY PARTICULAR FONT, STYLE, SIZE, OR COLOR.

FOR SUNGLASSES; COMPUTER SOFTWARE FOR THE DELIVERY OF TEXT, AUDIO, GRAPHICS AND VIDEO CONTENT RELATED TO HEALTH, FITNESS, LEISURE AND LIFESTYLE, AND FOR LOCATING HOTELS, MAKING HOTEL RESERVATIONS, AND MANAGING HOTEL OPERATIONS; PHOTOGRAPHIC APPARATUS AND INSTRUMENTS, NAMELY, CAMERAS, CAMERA LENSES, CAMERA HOUSINGS, BAGS FOR CAMERAS AND PHOTOGRAPHIC EQUIPMENT, BATTERIES, PHOTOGRAPHIC FILTERS, PHOTOGRAPHIC VIEW FINDERS, TRIPODS AND STANDS FOR PHOTOGRAPHIC APPARATUS; CINEMATOGRAPHIC APPARATUS AND INSTRUMENTS, NAMELY, CINEMATOGRAPHIC CAMERAS AND CINEMATOGRAPHIC PROJECTORS; OPTICAL APPARATUS AND INSTRUMENTS, NAMELY, TELESCOPES, MICROSCOPES, OPTICAL FRAMES, OPTICAL GLASSES, OPTICAL LENSES, OPTICAL MIRRORS, OPTICAL TELESCOPIC LENS SIGHTS, AND OPTICAL SCANNERS; APPARATUS FOR RECORDING, TRANSMISSION AND REPRODUCTION OF SOUND AND IMAGES; BLANK MAGNETIC DATA CARRIERS; PRE-RECORDED MAGNETIC DATA CARRIERS FEATURING DATA RECORDINGS OF AUDIO, VIDEO, STILL AND MOVING IMAGES AND TEXT IN THE FIELDS OF RECREATIONAL ACTIVITIES AND TRAVEL; BLANK RECORDABLE OPTICAL DISCS; DATA PROCESSORS; AND COMPUTERS (U.S. CLS. 21, 23, 26, 36 AND 38).

KATHERINE CHANG, EXAMINING ATTORNEY

CLASS 9—(Continued).

SN 85-304,860. ARGO, RANDY, SAN DIMAS, CA. FILED 4-26-2011.

FLOODGATE

THE MARK CONSISTS OF STANDARD CHARACTERS WITHOUT CLAIM TO ANY PARTICULAR FONT, STYLE, SIZE, OR COLOR.

FOR AUTOMOTIVE PARTS IN THE NATURE OF A WINDOW WASHER SYSTEM FOR BYPASSING THE EXISTING AUTOMOTIVE SYSTEM TO ALTERNATELY CONTROL FLUID APPLICATION TO THE WINDOW, NAMELY, ELECTRIC WIRES, ELECTRIC CONTROL UNITS AND AUTOMATIC CONTROL VALVES WHICH COUPLE TO THE WINDOW WIPER FLUID PUMP FOR CONTROLLING THE RELEASE OF FLUID AND A REMOTE CONTROL FOR USE IN ACTIVATING THE SYSTEM (U.S. CLS. 21, 23, 26, 36 AND 38).

BRENDAN MCCAULEY, EXAMINING ATTORNEY

SN 85-305,662. INTERNATIONAL MISSION BOARD OF THE SOUTHERN BAPTIST CONVENTION, RICHMOND, VA. FILED 4-27-2011.



THE MARK CONSISTS OF THE STYLIZED LOWER CASE LETTERS "IMB" WITH THE SCRIPT WORD "CONNECTING" UNDERNEATH AND SLIGHTLY TO THE RIGHT OF THE LETTERS "IMB".

FOR COMPUTER SOFTWARE PROGRAMS FOR THE INTEGRATION OF TEXT, AUDIO, GRAPHICS, STILL IMAGES AND MOVING PICTURES INTO AN INTERACTIVE DELIVERY FOR MULTIMEDIA APPLICATIONS FOR USE IN THE FIELDS OF WORLD EVANGELISM, RELIGIOUS EDUCATION, AND CHRISTIAN MISSIONS; PRE-RECORDED COMPACT DISCS FEATURING MUSIC AND RELIGIOUS SERMONS FOR USE IN THE FIELDS OF WORLD EVANGELISM, RELIGIOUS EDUCATION AND CHRISTIAN MISSIONS; VISUAL RECORDINGS AND AUDIO VISUAL RECORDINGS FEATURING COMPUTER GENERATED ANIMATION FOR USE IN THE FIELDS OF WORLD EVANGELISM, RELIGIOUS EDUCATION AND CHRISTIAN MISSIONS; DOWNLOADABLE TELEPHONE AND MOBILE PHONE RING TONES, GRAPHICS AND MUSIC VIA A GLOBAL COMPUTER NETWORK AND WIRELESS DEVICES FOR USE IN THE FIELDS OF WORLD EVANGELISM, RELIGIOUS EDUCATION AND CHRISTIAN MISSIONS; PRE-RECORDED CD-ROMS, DVD'S, AUDIO CASSETTES, VIDEO TAPES, AND LASER DISKS FEATURING RELIGIOUS EDUCATION, AND VIDEO GAME CARTRIDGES, ALL FOR USE IN THE FIELDS OF WORLD EVANGELISM, RELIGIOUS EDUCATION AND CHRISTIAN MISSIONS; SOUND, TEXT AND VIDEO RECORDINGS FEATURING RELIGIOUS EDUCATION FOR USE IN THE FIELDS OF WORLD EVAN-

CLASS 9—(Continued).

GELISM, RELIGIOUS EDUCATION AND CHRISTIAN MISSIONS; CINEMATOGRAPHIC FILMS FEATURING RELIGIOUS EDUCATION FOR USE IN THE FIELDS OF WORLD EVANGELISM, RELIGIOUS EDUCATION AND CHRISTIAN MISSIONS; ON-LINE DOWNLOADABLE MUSIC, ON-LINE DOWNLOADABLE BOOKS FEATURING RELIGIOUS EDUCATION, AND ON-LINE DOWNLOADABLE NEWSLETTER PUBLICATIONS FEATURING RELIGIOUS EDUCATION, ALL FOR USE IN THE FIELDS OF WORLD EVANGELISM, RELIGIOUS EDUCATION AND CHRISTIAN MISSIONS; ELECTRONIC PUBLICATIONS, NAMELY, BOOKS, MAGAZINE AND, MANUALS FEATURING RELIGIOUS EDUCATION RECORDED ON COMPUTER MEDIA AND VIEWED ON COMPUTER MONITORS, ON-LINE DOWNLOADABLE PUBLICATIONS, NAMELY, BOOKS, MAGAZINES AND MANUALS FEATURING RELIGIOUS EDUCATION VIEWED ON COMPUTER MONITORS, ALL FOR USE IN THE FIELDS OF WORLD EVANGELISM, RELIGIOUS EDUCATION AND CHRISTIAN MISSIONS (U.S. CLS. 21, 23, 26, 36 AND 38).

FIRST USE 6-15-2009; IN COMMERCE 6-15-2009.

JULIE GUTTADAURO, EXAMINING ATTORNEY

SN 85-306,647. TAJ, ZEESHAN, IRVING, TX. FILED 4-27-2011.

TOGGLEWAVE

THE MARK CONSISTS OF STANDARD CHARACTERS WITHOUT CLAIM TO ANY PARTICULAR FONT, STYLE, SIZE, OR COLOR.

FOR ELECTRICAL DEVICES, NAMELY, WIRELESS TOGGLE SWITCHES; WIRELESS IGNITION SYSTEM COMPRISED OF RELAYS, MICRO CONTROLLERS, RESISTORS AND CAPACITORS; WIRELESS ELECTRICAL SOCKETS; ELECTRONIC CIRCUITS; ENERGY USAGE MONITORING DEVICE, NAMELY, ENERGY METERS FOR TRACKING AND MONITORING ENERGY USAGE; SECURITY MONITORING DEVICE, NAMELY, WIRELESS TRANSCIEVERS AND SENSORS; SECURITY ALERT DEVICE, NAMELY, MICROPROCESSORS, WIRELESS TRANSCIEVERS AND MOTION SENSORS (U.S. CLS. 21, 23, 26, 36 AND 38).

DAWN FELDMAN, EXAMINING ATTORNEY

SN 85-308,004. COMMUNICATION DEVICES, INC., BOONTON, NJ. FILED 4-29-2011.

PA111

THE MARK CONSISTS OF STANDARD CHARACTERS WITHOUT CLAIM TO ANY PARTICULAR FONT, STYLE, SIZE, OR COLOR.

FOR APPARATUS FOR TRANSMISSION OF COMMUNICATION (U.S. CLS. 21, 23, 26, 36 AND 38).

FIRST USE 1-1-2011; IN COMMERCE 1-1-2011.

FRANK LATTUCA, EXAMINING ATTORNEY

CLASS 9—(Continued).

SN 85-308,601. NATIONAL BRAILLE PRESS, INC., BOSTON, MA. FILED 4-29-2011.

NBP NUGGET

THE MARK CONSISTS OF STANDARD CHARACTERS WITHOUT CLAIM TO ANY PARTICULAR FONT, STYLE, SIZE, OR COLOR.

FOR PERSONAL DIGITAL ASSISTANTS (PDAS) FOR USE BY THE VISUALLY IMPAIRED AND BRAILLE NOTE TAKERS (U.S. CLS. 21, 23, 26, 36 AND 38).

BARBARA BROWN, EXAMINING ATTORNEY

SN 85-309,937. TERATREND TECHNOLOGIES INC., NEW TAIPEI CITY 23585, TAIWAN, FILED 5-2-2011.

TERATREND

THE MARK CONSISTS OF STANDARD CHARACTERS WITHOUT CLAIM TO ANY PARTICULAR FONT, STYLE, SIZE, OR COLOR.

FOR COMPUTER HARDWARE; COMPUTER SOFTWARE AND HARDWARE FOR USE IN NETWORK MANAGEMENT; COMPUTER SOFTWARE AND FIRMWARE FOR OPERATING SYSTEM PROGRAMS; COMPUTER SOFTWARE FOR ACCESSING INFORMATION DIRECTORIES THAT MAY BE DOWNLOADED FROM THE GLOBAL COMPUTER NETWORK; COMPUTER SOFTWARE FOR APPLICATION AND DATABASE INTEGRATION; COMPUTER SOFTWARE FOR CREATING SEARCHABLE DATABASES OF INFORMATION AND DATA; COMPUTER SOFTWARE FOR COMMUNICATING WITH USERS OF HAND-HELD COMPUTERS; COMPUTER SOFTWARE FOR ADMINISTRATION OF COMPUTER LOCAL AREA NETWORKS; COMPUTER SOFTWARE FOR CONTROLLING AND MANAGING ACCESS SERVER APPLICATIONS; COMPUTER SOFTWARE FOR ENCRYPTION; COMPUTER SOFTWARE FOR WIRELESS CONTENT DELIVERY; COMPUTER SOFTWARE FOR PROVIDING AN ON-LINE DATABASE IN THE FIELD OF TRANSACTION PROCESSING TO UPLOAD TRANSACTIONAL DATA, PROVIDE STATISTICAL ANALYSIS, AND PRODUCE NOTIFICATIONS AND REPORTS; COMPUTER SOFTWARE FOR USE IN THE SAFEGUARDING OF DIGITAL FILES, INCLUDING AUDIO, VIDEO, TEXT, BINARY, STILL IMAGES, GRAPHICS AND MULTIMEDIA FILES; COMPUTER SOFTWARE FOR USE IN THE ENCRYPTION AND DECRYPTION OF DIGITAL FILES, INCLUDING AUDIO, VIDEO, TEXT, BINARY, STILL IMAGES, GRAPHICS AND MULTIMEDIA FILES; COMPUTER SOFTWARE FOR COMPUTER SYSTEM AND APPLICATION DEVELOPMENT, DEPLOYMENT AND MANAGEMENT; COMPUTER SOFTWARE FOR THE CREATION OF FIREWALLS; COMPUTER SOFTWARE FOR ADMINISTRATION OF COMPUTER NETWORKS; COMPUTER SOFTWARE THAT PROVIDES REAL-TIME, INTEGRATED BUSINESS MANAGEMENT INTELLIGENCE BY COMBINING INFORMATION FROM VARIOUS DATABASES AND PRESENTING IT IN AN EASY-TO-UNDERSTAND USER INTERFACE; COMPUTER SOFTWARE

CLASS 9—(Continued).

WARE TO ENABLE THE TRANSMISSION OF PHOTOGRAPHS TO MOBILE TELEPHONES; INTERFACE CARDS FOR USE IN COMPUTERS; TOUCH PANELS FOR USE IN COMPUTERS; GRAPHIC TABLET FOR COMPUTERS; BAGS FOR PORTABLE COMPUTERS; REMOVABLE BLANK CARTRIDGES FOR HARD DISK DRIVES; DVD BURNERS FOR USE IN COMPUTERS; ELECTRONIC SECURITY TOKEN IN THE NATURE OF A FOB-LIKE DEVICE USED BY AN AUTHORIZED USER OF A COMPUTER SYSTEM FACILITATE AUTHENTICATION; DVD BURNERS; BAGS FOR NOTEBOOK COMPUTERS; BAGS FOR TABLET COMPUTERS; BAGS FOR PERSONAL DIGITAL ASSISTANTS; BATTERIES; ELECTRICAL POWER SUPPLIES; UNINTERRUPTIBLE ELECTRICAL POWER SUPPLIES; REMOTE CONTROL FOR USE IN THE COMPUTERS; BATTERY CHARGERS; BATTERY CHARGERS FOR USE IN MOBILE PHONES; EXTERNAL STORAGE DEVICES ENCLOSURES; RAID SYSTEM ENCLOSURES; NETWORK ATTACHED STORAGE DEVICES ENCLOSURES (U.S. CLS. 21, 23, 26, 36 AND 38).

CHRIS WELLS, EXAMINING ATTORNEY

SN 85-309,947. SPARTAN MOTORS, INC., CHARLOTTE, MI. FILED 5-2-2011.

CRIMSON FIRE

THE MARK CONSISTS OF STANDARD CHARACTERS WITHOUT CLAIM TO ANY PARTICULAR FONT, STYLE, SIZE, OR COLOR.

OWNER OF U.S. REG. NO. 2,911,856.

NO CLAIM IS MADE TO THE EXCLUSIVE RIGHT TO USE "FIRE", APART FROM THE MARK AS SHOWN.

FOR FIRE TRUCKS; RESCUE TRUCKS SPECIALLY EQUIPPED FOR PHYSICAL RESCUE AND NOT MEDICAL CARE; AERIALS (U.S. CLS. 21, 23, 26, 36 AND 38).

FIRST USE 1-31-2003; IN COMMERCE 1-31-2003.

ANNE E. GUSTASON, EXAMINING ATTORNEY

SN 85-310,653. TDNC CORPORATION, RESTON, VA. FILED 5-3-2011.

SITTERCIRCLES

THE MARK CONSISTS OF STANDARD CHARACTERS WITHOUT CLAIM TO ANY PARTICULAR FONT, STYLE, SIZE, OR COLOR.

FOR DOWNLOADABLE SOFTWARE IN THE NATURE OF A MOBILE APPLICATION FOR USE IN THE FIELD OF HELPING INDIVIDUALS FIND AND ORGANIZE BABY AND CHILD SITTING SERVICES THROUGH A SHARED NETWORK OF SITTERS AND PARENTS (U.S. CLS. 21, 23, 26, 36 AND 38).

MICHELLE DUBOIS, EXAMINING ATTORNEY

CLASS 9—(Continued).

SN 85-310,984. IQOR TECHNOLOGIES, INC., NEW YORK, NY. FILED 5-3-2011.

QALLBAR

THE MARK CONSISTS OF STANDARD CHARACTERS WITHOUT CLAIM TO ANY PARTICULAR FONT, STYLE, SIZE, OR COLOR.

FOR SOFTWARE THAT ENABLES TELEPHONE ACTIVITIES TO BE PERFORMED THROUGH A COMPUTER; TELEPHONE ROUTERS AND COMPUTER AND TELEPHONY HARDWARE (U.S. CLS. 21, 23, 26, 36 AND 38).

KATHLEEN LORENZO, EXAMINING ATTORNEY

SN 85-312,302. VICON INDUSTRIES INC., HAUPPAUGE, NY. FILED 5-4-2011.

SURVEYOR

THE MARK CONSISTS OF STANDARD CHARACTERS WITHOUT CLAIM TO ANY PARTICULAR FONT, STYLE, SIZE, OR COLOR.

OWNER OF U.S. REG. NO. 3,705,071.
FOR CAMERA DOMES (U.S. CLS. 21, 23, 26, 36 AND 38).

FIRST USE 0-0-1996; IN COMMERCE 0-0-1996.
SCOTT BIBB, EXAMINING ATTORNEY

SN 85-313,128. CASE ENGINEERING, LLC, AKA CASE CONTROLS, EVANSVILLE, IN. FILED 5-5-2011.

AIRSTAR

THE MARK CONSISTS OF STYLIZED LETTERS "A I R S T A R".

FOR A LADDER LOGIC SOFTWARE PROGRAM DESIGNED TO RUN ON COMMERCIALY AVAILABLE PROGRAMMABLE LOGIC CONTROLLER PLATFORMS FOR THE SPECIFIC PURPOSE OF CONTROLLING THE INLET GUIDE VANES AND BY-PASS VALVES OF A CENTRIFUGAL AIR COMPRESSOR WITH A CONTROL ALGORITHM WITH THE INTENTION OF IMPROVING TURNDOWN CAPACITY OF THE THROTTLE RANGE (U.S. CLS. 21, 23, 26, 36 AND 38).

FIRST USE 7-1-2004; IN COMMERCE 11-17-2004.
JOSETTE BEVERLY, EXAMINING ATTORNEY

CLASS 9—(Continued).

SN 85-313,326. HOGENTOGLER & CO., INC., DBA HOGENTOGLER & CO., INC., COLUMBIA, MD. FILED 5-5-2011.



THE MARK CONSISTS OF THE WORD "VERITAS" IN A STYLIZED FORMAT HAVING BOLD DESIGNED LETTERS SLANTED TO THE RIGHT WITH A LARGE LETTER "V" IN THE BEGINNING WITH A TALL LETTER "T" IN THE MIDDLE.

THE ENGLISH TRANSLATION OF "VERITAS" IN THE MARK IS "TRUTH".

FOR WEIGHING EQUIPMENT, NAMELY, SCALES AND BALANCES (U.S. CLS. 21, 23, 26, 36 AND 38).

JESSICA FATHY, EXAMINING ATTORNEY

SN 85-317,922. ZENGAR INSTITUTE INC., VICTORIA, CANADA, FILED 5-11-2011.

Dynamical Neurofeedback

THE MARK CONSISTS OF STANDARD CHARACTERS WITHOUT CLAIM TO ANY PARTICULAR FONT, STYLE, SIZE, OR COLOR.

NO CLAIM IS MADE TO THE EXCLUSIVE RIGHT TO USE "NEUROFEEDBACK", APART FROM THE MARK AS SHOWN.

FOR COMPUTER SOFTWARE FOR USE RECEIVING AND PROCESSING DATA REFLECTIVE OF NEURAL ACTIVITY AND GENERATING REPRESENTATIVE VISUAL IMAGES, SOUNDS AND MULTIMEDIA EVENTS BASED ON DATA SIGNALS (U.S. CLS. 21, 23, 26, 36 AND 38).

FIRST USE 2-1-2000; IN COMMERCE 2-1-2000.
MICHAEL WIENER, EXAMINING ATTORNEY

CLASS 9—(Continued).

SN 85-321,770. VERSATILE SYSTEMS, INC., MECHANICSBURG, PA. FILED 5-16-2011.



NO CLAIM IS MADE TO THE EXCLUSIVE RIGHT TO USE "SMART SIGN", APART FROM THE MARK AS SHOWN.

THE COLOR(S) RED, WHITE AND BLACK IS/ARE CLAIMED AS A FEATURE OF THE MARK.

THE MARK CONSISTS OF A WHITE RECTANGLE CONTAINING THE WORD "SMART" IN BLACK, NEXT TO A BLACK RECTANGLE CONTAINING THE WORD "SIGN" IN WHITE. IN THE UPPER LEFT CORNER, THERE IS A RED CIRCLE CONTAINING A WHITE LETTER "V", FOLLOWED BY THE WORD "VERSATILE" IN BLACK.

FOR ELECTRONIC DISPLAYS, NAMELY, DIGITAL SIGNAGE PROVIDING A DYNAMIC AND POTENTIALLY INTERACTIVE USER EXPERIENCE (U.S. CLS. 21, 23, 26, 36 AND 38).

FIRST USE 2-21-2011; IN COMMERCE 2-21-2011.
DORITT L. CARROLL, EXAMINING ATTORNEY

CLASS 9—(Continued).

SN 85-322,779. PLAYBOY ENTERPRISES INTERNATIONAL, INC., CHICAGO, IL. FILED 5-17-2011.

THE PLAYBOY CLUB

THE MARK CONSISTS OF STANDARD CHARACTERS WITHOUT CLAIM TO ANY PARTICULAR FONT, STYLE, SIZE, OR COLOR.

OWNER OF U.S. REG. NOS. 3,172,072, 3,500,652 AND OTHERS.

FOR PRE-RECORDED DVDS FEATURING DRAMA; PRE-RECORDED CDS FEATURING DRAMA AND MUSICAL PERFORMANCES; DOWNLOADABLE AUDIO AND VIDEO RECORDINGS FEATURING DRAMA; DOWNLOADABLE TELEVISION SHOWS AND VIDEO RECORDINGS FEATURING DRAMA; DOWNLOADABLE RING TONES, RING BACKS, GRAPHICS, WALLPAPER, GAMES AND MUSIC VIA A GLOBAL COMPUTER NETWORK AND WIRELESS DEVICES; COMPUTER SCREEN SAVER SOFTWARE; COMPUTER GAME AND VIDEO GAME SOFTWARE; MOUSEPADS; DECORATIVE MAGNETS (U.S. CLS. 21, 23, 26, 36 AND 38).

MARTHA FROMM, EXAMINING ATTORNEY

SN 85-322,592. TMC ENTERPRISES, INC. A DIVISION OF TASCO INDUSTRIES, INC., CHINO, CA. FILED 5-17-2011.

E-ZEE LINK

THE MARK CONSISTS OF STANDARD CHARACTERS WITHOUT CLAIM TO ANY PARTICULAR FONT, STYLE, SIZE, OR COLOR.

NO CLAIM IS MADE TO THE EXCLUSIVE RIGHT TO USE "LINK", APART FROM THE MARK AS SHOWN.

FOR ELECTRICAL EXTENSION CORDS INCORPORATING A LOCKING MECHANISM FOR MAINTAINING ELECTRICAL PLUGS IN CONTACT WITH EACH OTHER (U.S. CLS. 21, 23, 26, 36 AND 38).

FIRST USE 4-21-2011; IN COMMERCE 4-21-2011.
JILL C. ALT, EXAMINING ATTORNEY

SN 85-322,881. ARCSOFT, INC., FREMONT, CA. FILED 5-17-2011.

ARCSOFT TOTALBACKUP

THE MARK CONSISTS OF STANDARD CHARACTERS WITHOUT CLAIM TO ANY PARTICULAR FONT, STYLE, SIZE, OR COLOR.

OWNER OF U.S. REG. NOS. 2,334,476, 3,091,316 AND OTHERS.

NO CLAIM IS MADE TO THE EXCLUSIVE RIGHT TO USE "TOTAL BACKUP", APART FROM THE MARK AS SHOWN.

FOR COMPUTER SOFTWARE FOR DATA AND SYSTEM PROTECTION, RECOVERY, BACKUP, RESTORATION AND RETRIEVAL (U.S. CLS. 21, 23, 26, 36 AND 38).

SUZANNE BLANE, EXAMINING ATTORNEY

CLASS 9—(Continued).

SN 85-328,733. ASCOREL USA, LLC, KENNESAW, GA. FILED 5-24-2011.



THE COLOR(S) YELLOW, BLUE AND WHITE IS/ARE CLAIMED AS A FEATURE OF THE MARK.

THE MARK CONSISTS OF A BLUE AND YELLOW STYLIZED A ABOVE THE WORD "ASCOREL" WITH YELLOW LETTERS WITH BLUE OUTLINE, ALL ON A WHITE BACKGROUND.

FOR WEIGHING SYSTEMS COMPRISING WEIGHING MACHINES FOR HEAVY EQUIPMENT; ANTI-COLLISION SYSTEMS COMPRISING BRAKE CONTROLLERS AND WIND FILTER CONTROLLERS TO PREVENT CRANES AND OTHER HEAVY PIECES OF EQUIPMENT FROM FLYING OVER FORBIDDEN ZONES AND COLLIDING WITH EACH OTHER; WIND SPEED METERS AND SENSORS THEREFOR (U.S. CLS. 21, 23, 26, 36 AND 38).

FIRST USE 4-30-2006; IN COMMERCE 4-30-2006.
KARANENDRA S. CHHINA, EXAMINING ATTORNEY

CLASS 9—(Continued).

SN 85-331,813. SAMSUNG ELECTRONICS CO., LTD., SUWON-SI, GYEONGGI-DO, REPUBLIC OF KOREA, FILED 5-26-2011.

TRUCOLOR SPECTRUM

THE MARK CONSISTS OF STANDARD CHARACTERS WITHOUT CLAIM TO ANY PARTICULAR FONT, STYLE, SIZE, OR COLOR.

FOR LIQUID CRYSTAL DISPLAYS, ACTIVE-MATRIX ORGANIC LIGHT-EMITTING DIODE DISPLAYS AND ORGANIC LIGHT-EMITTING DIODE DISPLAYS FOR SMART PHONES AND TABLET COMPUTERS (U.S. CLS. 21, 23, 26, 36 AND 38).

TINA BROWN, EXAMINING ATTORNEY

SN 85-331,956. HAMPTON, TIMOTHY E., CERRITOS, CA. FILED 5-27-2011.

DACAPO MUSIC GROUP

SN 85-329,159. 1ST DETECT CORPORATION, HOUSTON, TX. FILED 5-24-2011.

1st Detect

THE MARK CONSISTS OF STANDARD CHARACTERS WITHOUT CLAIM TO ANY PARTICULAR FONT, STYLE, SIZE, OR COLOR.

NO CLAIM IS MADE TO THE EXCLUSIVE RIGHT TO USE "DETECT", APART FROM THE MARK AS SHOWN.

FOR PORTABLE CHEMICAL DETECTOR CAPABLE OF DETECTING RESIDUES AND VAPORS FROM A WIDE RANGE OF CHEMICALS INCLUDING EXPLOSIVES, CHEMICAL WARFARE AGENTS, TOXIC CHEMICALS, AND VOLATILE ORGANIC COMPOUNDS (U.S. CLS. 21, 23, 26, 36 AND 38).

THOMAS MANOR, EXAMINING ATTORNEY

NO CLAIM IS MADE TO THE EXCLUSIVE RIGHT TO USE "MUSIC GROUP", APART FROM THE MARK AS SHOWN.

THE MARK CONSISTS OF "DACAPO MUSIC GROUP" IN A STYLIZED FORMAT.

THE ENGLISH TRANSLATION OF THE WORD "DACAPO" IN THE MARK IS "FROM THE BEGINNING".

FOR AUDIO AND VIDEO RECORDINGS FEATURING MUSIC AND ARTISTIC PERFORMANCES; COMPACT DISCS FEATURING MUSIC; COMPACT DISCS FEATURING MUSIC AND SPOKEN WORD IN THE FORM OF POETRY; DIGITAL MUSIC DOWNLOADABLE FROM THE INTERNET; DOWNLOADABLE MP3 FILES, MP3 RECORDINGS, ON-LINE DISCUSSION BOARDS, WEBCASTS, WEBINARS AND PODCASTS FEATURING MUSIC, AUDIO BOOKS IN THE FIELD OF MUSIC, AND NEWS BROADCASTS; DOWNLOADABLE MUSICAL SOUND RECORDINGS; DOWNLOADABLE RING TONES, GRAPHICS AND MUSIC VIA A GLOBAL COMPUTER NETWORK AND WIRELESS DEVICES; DOWNLOADABLE VIDEO RECORDINGS FEATURING MUSIC; DOWNLOADABLE MUSIC VIA THE INTERNET AND WIRELESS DEVICES; INTERACTIVE MUSIC MANUSCRIPT IN MULTIMEDIA VIDEO GAME FORMAT DISTRIBUTED AS DOWNLOADABLE OR DIGITAL MEDIA; MUSICAL RECORDINGS; MUSICAL SOUND RECORDINGS; MUSICAL VIDEO RECORDINGS; PHONOGRAPH RECORDS FEATURING MUSIC; SERIES OF MUSICAL SOUND RECORDINGS; SOUND RECORDINGS FEATURING MUSIC; VIDEO RECORDINGS FEATURING MUSIC (U.S. CLS. 21, 23, 26, 36 AND 38).

FIRST USE 5-16-2004; IN COMMERCE 3-16-2011.
WENDY JUN, EXAMINING ATTORNEY

CLASS 9—(Continued).

SN 85-333,903. UNIDISC MUSIC INC., POINTE CLAIRE QUEBEC, CANADA, FILED 5-31-2011.



NO CLAIM IS MADE TO THE EXCLUSIVE RIGHT TO USE "LOS ANGELES RECORDS", APART FROM THE MARK AS SHOWN.

THE MARK CONSISTS OF THE WORDS IN CAPITAL LETTERS, "SOUND OF LOS ANGELES RECORDS", IN A HALF CIRCLE IN A CONCAVE SHAPE.

FOR SOUND RECORDINGS FEATURING MUSIC; PHONOGRAPHIC RECORDS, AUDIO TAPES, AUDIO CASSETTES, AUDIO DISCS, COMPACT DISCS, CD ROMS, ENHANCED CDS, AND DIGITAL AUDIO TAPES FEATURING MUSIC; VIDEO TAPES, DVDS, AND LASER DISCS FEATURING MUSIC; PRERECORDED CD-ROMS, DIGITAL AUDIO TAPES, AND DVDS FEATURING MUSIC; DOWNLOADABLE MP3 FILES FEATURING MUSIC, AND PRERECORDED MAGNETIC DATA CARRIERS FEATURING MUSIC (U.S. CLS. 21, 23, 26, 36 AND 38).

FIRST USE 6-1-1981; IN COMMERCE 6-1-1981.
SEAN CROWLEY, EXAMINING ATTORNEY

SN 85-334,868. OBJECTIVE SOFTWARE CORPORATION, RALEIGH, NC. FILED 6-1-2011.

ObjectiveDB

THE MARK CONSISTS OF STANDARD CHARACTERS WITHOUT CLAIM TO ANY PARTICULAR FONT, STYLE, SIZE, OR COLOR.

FOR COMPUTER SOFTWARE TO MANAGE, ANALYZE, RETRIEVE, MONITOR, MAINTAIN, REPORT ON, STRUCTURE, MODEL, FORECAST, PRESENT AND DISPLAY DATA AND INFORMATION FROM COMPUTER DATABASES AND THE INTERNET, AND FOR THE DEVELOPMENT, ANALYSIS, MANAGEMENT, INTEGRATION, DEPLOYMENT AND MAINTENANCE OF COMPUTER SOFTWARE; WEB SERVICES SOFTWARE, APPLICATION SERVER SOFTWARE, DATABASE SOFTWARE, BUSINESS INTELLIGENCE SOFTWARE, INTERNET AND INTRANET PORTAL SOFTWARE, DATA WAREHOUSING SOFTWARE, CONTENT MANAGEMENT SOFTWARE, ONLINE TRADING SOFTWARE, ONLINE TRAINING SOFTWARE, TELEPHONY SOFTWARE, FAX MESSAGING SOFTWARE, ELECTRONIC MAIL SOFTWARE, SCHEDULING SOFT-

CLASS 9—(Continued).

WARE, WIRELESS COMMUNICATIONS SOFTWARE, AND VOICE ENABLEMENT SOFTWARE; COMPUTER SOFTWARE APPLICATIONS IN THE FIELDS OF MARKETING, SALES, CUSTOMER SERVICE, CONTRACTS, HUMAN RESOURCES, CLINICAL RESEARCH, HEALTH CARE, EDUCATION, COMMUNICATIONS AND TELECOMMUNICATIONS, CALL CENTERS, PUBLIC SECTOR ADMINISTRATION, PUBLIC AND PRIVATE UTILITIES, PROCESSING, ANALYSIS AND MANAGEMENT OF FINANCIAL TRANSACTIONS, MANAGEMENT OF SUPPLY CHAINS, ORDERS, PROCUREMENT, INVENTORY, ASSETS, PROJECTS AND MANUFACTURING, BUSINESS CONSOLIDATION MANAGEMENT, BUSINESS RISK MANAGEMENT, BUSINESS QUALITY MANAGEMENT, BUSINESS PROJECT MANAGEMENT, BUSINESS STAKEHOLDER-SHAREHOLDER RELATIONSHIP MANAGEMENT, AND STRATEGIC BUSINESS, SIMULATION, ENTERPRISE AND RESOURCE PLANNING; AND INSTRUCTIONAL MANUALS SOLD AS A UNIT (U.S. CLS. 21, 23, 26, 36 AND 38).

DOMINICK J. SALEMI, EXAMINING ATTORNEY

SN 85-334,904. OBJECTIVE SOFTWARE CORPORATION, RALEIGH, NC. FILED 6-1-2011.

ObjectiveSQL

THE MARK CONSISTS OF STANDARD CHARACTERS WITHOUT CLAIM TO ANY PARTICULAR FONT, STYLE, SIZE, OR COLOR.

FOR COMPUTER SOFTWARE FOR USE IN CREATING, MANAGING, SEARCHING, EDITING, AND OPERATING DATABASES (U.S. CLS. 21, 23, 26, 36 AND 38).
DOMINICK J. SALEMI, EXAMINING ATTORNEY

SN 85-334,918. OBJECTIVE SOFTWARE CORPORATION, RALEIGH, NC. FILED 6-1-2011.

ObjectiveDBS

THE MARK CONSISTS OF STANDARD CHARACTERS WITHOUT CLAIM TO ANY PARTICULAR FONT, STYLE, SIZE, OR COLOR.

FOR COMPUTER SOFTWARE TO MANAGE, ANALYZE, RETRIEVE, MONITOR, MAINTAIN, REPORT ON, STRUCTURE, MODEL, FORECAST, PRESENT AND DISPLAY DATA AND INFORMATION FROM COMPUTER DATABASES AND THE INTERNET, AND FOR THE DEVELOPMENT, ANALYSIS, MANAGEMENT, INTEGRATION, DEPLOYMENT AND MAINTENANCE OF COMPUTER SOFTWARE; WEB SERVICES SOFTWARE, APPLICATION SERVER SOFTWARE, DATABASE SOFTWARE, BUSINESS INTELLIGENCE SOFTWARE, INTERNET AND INTRANET PORTAL SOFTWARE, DATA WAREHOUSING SOFTWARE, CONTENT MANAGEMENT SOFTWARE, ONLINE TRADING SOFTWARE, ONLINE TRAINING SOFTWARE, TELEPHONY SOFTWARE, FAX MESSAGING SOFTWARE, ELECTRONIC MAIL SOFTWARE, SCHEDULING SOFT-

CLASS 9—(Continued).

WARE, WIRELESS COMMUNICATIONS SOFTWARE, AND VOICE ENABLEMENT SOFTWARE; COMPUTER SOFTWARE APPLICATIONS IN THE FIELDS OF MARKETING, SALES, CUSTOMER SERVICE, CONTRACTS, HUMAN RESOURCES, CLINICAL RESEARCH, HEALTH CARE, EDUCATION, COMMUNICATIONS AND TELECOMMUNICATIONS, CALL CENTERS, PUBLIC SECTOR ADMINISTRATION, PUBLIC AND PRIVATE UTILITIES, PROCESSING, ANALYSIS AND MANAGEMENT OF FINANCIAL TRANSACTIONS, MANAGEMENT OF SUPPLY CHAINS, ORDERS, PROCUREMENT, INVENTORY, ASSETS, PROJECTS AND MANUFACTURING, BUSINESS CONSOLIDATION MANAGEMENT, BUSINESS RISK MANAGEMENT, BUSINESS QUALITY MANAGEMENT, BUSINESS PROJECT MANAGEMENT, BUSINESS STAKEHOLDER-SHAREHOLDER RELATIONSHIP MANAGEMENT, AND STRATEGIC BUSINESS, SIMULATION, ENTERPRISE AND RESOURCE PLANNING; AND INSTRUCTIONAL MANUALS SOLD AS A UNIT (U.S. CLS. 21, 23, 26, 36 AND 38).

DOMINICK J. SALEMI, EXAMINING ATTORNEY

SN 85-336,724. DRAGON ALLIANCE, LLC, CARLSBAD, CA. FILED 6-2-2011.

VICEROY

THE MARK CONSISTS OF STANDARD CHARACTERS WITHOUT CLAIM TO ANY PARTICULAR FONT, STYLE, SIZE, OR COLOR.

FOR PROTECTIVE AND/OR ANTIGLARE EYEWEAR, NAMELY, SUNGLASSES AND SPORTS GOGGLES AND PARTS AND ACCESSORIES THEREFOR, NAMELY, REPLACEMENT LENSES, EAR STEMS, FRAMES, NOSE PIECES AND FOAM STRIPS; AND CASES SPECIALLY ADAPTED FOR PROTECTIVE AND/OR ANTI-GLARE EYEWEAR (U.S. CLS. 21, 23, 26, 36 AND 38).

LEIGH CAROLINE CASE, EXAMINING ATTORNEY

SN 85-336,733. DRAGON ALLIANCE, LLC, CARLSBAD, CA. FILED 6-2-2011.

ROOSEVELT

THE MARK CONSISTS OF STANDARD CHARACTERS WITHOUT CLAIM TO ANY PARTICULAR FONT, STYLE, SIZE, OR COLOR.

FOR PROTECTIVE AND/OR ANTIGLARE EYEWEAR, NAMELY, SUNGLASSES AND SPORTS GOGGLES AND PARTS AND ACCESSORIES THEREFOR, NAMELY, REPLACEMENT LENSES, EAR STEMS, FRAMES, NOSE PIECES AND FOAM STRIPS; AND CASES SPECIALLY ADAPTED FOR PROTECTIVE AND/OR ANTI-GLARE EYEWEAR (U.S. CLS. 21, 23, 26, 36 AND 38).

LEIGH CAROLINE CASE, EXAMINING ATTORNEY

CLASS 9—(Continued).

SN 85-339,493. ANALYSIS SOLUTION LLC, DBA GEARBIT, AUSTIN, TX. FILED 6-7-2011.

gearbit

THE MARK CONSISTS OF STANDARD CHARACTERS WITHOUT CLAIM TO ANY PARTICULAR FONT, STYLE, SIZE, OR COLOR.

FOR COMPUTER NETWORK SERVER (U.S. CLS. 21, 23, 26, 36 AND 38).

FIRST USE 2-20-2008; IN COMMERCE 2-20-2008.
ANNE E. GUSTASON, EXAMINING ATTORNEY

SN 85-341,074. SANDISK CORPORATION, MILPITAS, CA. FILED 6-8-2011.

CRUZER FIT

THE MARK CONSISTS OF STANDARD CHARACTERS WITHOUT CLAIM TO ANY PARTICULAR FONT, STYLE, SIZE, OR COLOR.

OWNER OF U.S. REG. NOS. 2,754,118, 3,104,782 AND OTHERS.

FOR BLANK USB FLASH DRIVES; PRE-RECORDED USB FLASH DRIVES FEATURING SOFTWARE FOR SECURITY AND ENCRYPTION OF DATA; EXTERNAL COMPUTER HARD DRIVE WITH A USB CONNECTION (U.S. CLS. 21, 23, 26, 36 AND 38).

MAYUR VAGHANI, EXAMINING ATTORNEY

SN 85-350,689. MARK ALVA MARTINEZ, SUWANEE, GA. FILED 6-20-2011.

AZECA

THE MARK CONSISTS OF STANDARD CHARACTERS WITHOUT CLAIM TO ANY PARTICULAR FONT, STYLE, SIZE, OR COLOR.

FOR CONSUMER ELECTRONIC DEVICES, NAMELY, CORDED AND WIRELESS HEADSETS FOR CELLULAR OR MOBILE PHONES, HEADPHONES FOR PORTABLE MEDIA PLAYERS, AUDIO SPEAKERS, MICROPHONES, ELECTRONIC TRANSMITTERS AND WEARABLE RECEIVERS FOR TRANSMITTING AND RECEIVING STREAMED AUDIO AND VIDEO SIGNALS FROM COMPUTERS AND PORTABLE MEDIA PLAYERS, AND EARPHONE ACCESSORIES, NAMELY, EARPHONE CUSHIONS, EARPHONE PADS, CORD MANAGEMENT SYSTEMS, EARPHONE CASES, AND EARPHONE EXTENSION CORDS FOR USE WITH MOBILE TELEPHONES AND PORTABLE MEDIA PLAYERS (U.S. CLS. 21, 23, 26, 36 AND 38).

NELSON SNYDER, EXAMINING ATTORNEY

CLASS 9—(Continued).

SN 85-351,474. LIBERTY PL SERVICES, LLC, AKA LIBERTY PIPELINE SERVICES, LLC, SPRING, TX. FILED 6-21-2011.

Liberty Live!

THE MARK CONSISTS OF STANDARD CHARACTERS WITHOUT CLAIM TO ANY PARTICULAR FONT, STYLE, SIZE, OR COLOR.

FOR COMPUTER SOFTWARE FOR APPLICATION AND DATABASE INTEGRATION (U.S. CLS. 21, 23, 26, 36 AND 38).

FIRST USE 6-15-2008; IN COMMERCE 6-15-2008.
WILLIAM ROSSMAN, EXAMINING ATTORNEY

SN 85-352,972. NAVAL RESEARCH LABORATORY, WASHINGTON, DC. FILED 6-22-2011.

SIMDIS SDK

THE MARK CONSISTS OF STANDARD CHARACTERS WITHOUT CLAIM TO ANY PARTICULAR FONT, STYLE, SIZE, OR COLOR.

OWNER OF U.S. REG. NOS. 3,712,353 AND 3,712,354. NO CLAIM IS MADE TO THE EXCLUSIVE RIGHT TO USE "SDK", APART FROM THE MARK AS SHOWN.

FOR COMPUTER SYSTEMS COMPRISED OF COMPUTER HARDWARE AND SOFTWARE, COMPATIBLE WITH OPEN SOURCE LIBRARIES AND ADD-ON APPLICATIONS, FOR INTERACTIVE THREE-DIMENSIONAL VISUALIZATION AND ANALYSIS OF LIVE AND SIMULATION DATA, EXCLUDING COMPUTER GAME SOFTWARE (U.S. CLS. 21, 23, 26, 36 AND 38).

FIRST USE 4-9-2010; IN COMMERCE 4-9-2010.
ERNEST SHOSHO, EXAMINING ATTORNEY

SN 85-354,514. DUACARRIER ELECTRONICS TECHNOLOGY, INC., KNOXVILLE, TN. FILED 6-23-2011.

VERIMAX

THE MARK CONSISTS OF STANDARD CHARACTERS WITHOUT CLAIM TO ANY PARTICULAR FONT, STYLE, SIZE, OR COLOR.

FOR CABLES, ELECTRIC; COMPUTER CABLES; ELECTRONIC CABLES (U.S. CLS. 21, 23, 26, 36 AND 38). FIRST USE 12-0-2009; IN COMMERCE 12-0-2009.

DAVID H. STINE, EXAMINING ATTORNEY

CLASS 9—(Continued).

SN 85-354,804. WEIDER HEALTH AND FITNESS, WOODLAND HILLS, CA. FILED 6-23-2011.

MR. OLYMPIA

THE MARK CONSISTS OF STANDARD CHARACTERS WITHOUT CLAIM TO ANY PARTICULAR FONT, STYLE, SIZE, OR COLOR.

OWNER OF U.S. REG. NOS. 3,951,271, 3,958,216 AND OTHERS.

FOR SERIES OF PRE-RECORDED DVDS AND VIDEO TAPES FEATURING BODYBUILDING CONTESTS AND COMPETITIONS, AND SHOWS FEATURING BODYBUILDERS AND AWARDS CEREMONIES (U.S. CLS. 21, 23, 26, 36 AND 38).

FIRST USE 9-0-1980; IN COMMERCE 9-0-1980.
YAT SYE, LEE, EXAMINING ATTORNEY

SN 85-358,734. SANDISK CORPORATION, MILPITAS, CA. FILED 6-28-2011.

CLOUD CATCHER

THE MARK CONSISTS OF STANDARD CHARACTERS WITHOUT CLAIM TO ANY PARTICULAR FONT, STYLE, SIZE, OR COLOR.

NO CLAIM IS MADE TO THE EXCLUSIVE RIGHT TO USE "CLOUD", APART FROM THE MARK AS SHOWN.

FOR SOFTWARE FOR DATA BACK-UP FROM THE INTERNET (U.S. CLS. 21, 23, 26, 36 AND 38).

MAYUR VAGHANI, EXAMINING ATTORNEY

SN 85-368,856. BLACK & DECKER CORPORATION, THE, TOWSON, MD. FILED 7-12-2011.



NO CLAIM IS MADE TO THE EXCLUSIVE RIGHT TO USE "FAST CHARGER", APART FROM THE MARK AS SHOWN.

THE MARK CONSISTS OF THE STYLIZED WORDING "FAST CHARGER" TO THE LEFT OF A DESIGN OF A STOP WATCH.

FOR BATTERY CHARGERS (U.S. CLS. 21, 23, 26, 36 AND 38).

KRISTINA MORRIS, EXAMINING ATTORNEY

CLASS 9—(Continued).

SN 85-373,731. VMWARE, INC., PALO ALTO, CA. FILED 7-18-2011.

VNOW

THE MARK CONSISTS OF STANDARD CHARACTERS WITHOUT CLAIM TO ANY PARTICULAR FONT, STYLE, SIZE, OR COLOR.

FOR PRODUCTIVITY AND ENTERPRISE OFFICE SUITE SOFTWARE, NAMELY, COMMUNICATIONS SOFTWARE AND GROUPWARE FOR USE IN WORD PROCESSING, ELECTRONIC MAIL, INSTANT MESSAGING, WEB COLLABORATION, DOCUMENT SHARING; SOFTWARE FOR USE IN ORGANIZING, ANALYZING AND PRESENTING DATA; SOFTWARE FOR MANAGING, TESTING AND USING OPERATING SYSTEMS; APPLICATION DEVELOPMENT AND APPLICATION MANAGEMENT SOFTWARE (U.S. CLS. 21, 23, 26, 36 AND 38).

ANN E. SAPPENFIELD, EXAMINING ATTORNEY

SN 85-373,735. VMWARE, INC., PALO ALTO, CA. FILED 7-18-2011.

VQUO

THE MARK CONSISTS OF STANDARD CHARACTERS WITHOUT CLAIM TO ANY PARTICULAR FONT, STYLE, SIZE, OR COLOR.

FOR PRODUCTIVITY AND ENTERPRISE OFFICE SUITE SOFTWARE, NAMELY, COMMUNICATIONS SOFTWARE AND GROUPWARE FOR USE IN WORD PROCESSING, ELECTRONIC MAIL, INSTANT MESSAGING, WEB COLLABORATION, DOCUMENT SHARING; SOFTWARE FOR USE IN ORGANIZING, ANALYZING AND PRESENTING DATA; SOFTWARE FOR MANAGING, TESTING AND USING OPERATING SYSTEMS; APPLICATION DEVELOPMENT AND APPLICATION MANAGEMENT SOFTWARE (U.S. CLS. 21, 23, 26, 36 AND 38).

ANN E. SAPPENFIELD, EXAMINING ATTORNEY

CLASS 9—(Continued).

SN 85-379,285. MAGNETU MOBILE LTD, KFAR SABA, ISRAEL, FILED 7-24-2011.

magnetu
with people you like

THE MARK CONSISTS OF THE WORD "MAGNETU", STYLIZED, WITH TWO DOTS OVER THE LETTER "U", UNDERNEATH WHICH IS THE WORDING "WITH PEOPLE YOU LIKE".

THE WORDING "MAGNETU" HAS NO MEANING IN A FOREIGN LANGUAGE.

FOR WEARABLE SOCIAL NETWORKING ACCESSORY, NAMELY, A WIRELESS COMMUNICATION DEVICE FOR VOICE, DATA, OR IMAGE TRANSMISSION (U.S. CLS. 21, 23, 26, 36 AND 38).

FIRST USE 4-10-2011; IN COMMERCE 6-23-2011.

BARNEY CHARLON, EXAMINING ATTORNEY

SN 85-380,040. THE INFORMATION STORE, INC., HOUSTON, TX. FILED 7-25-2011.

QVA

THE MARK CONSISTS OF STANDARD CHARACTERS WITHOUT CLAIM TO ANY PARTICULAR FONT, STYLE, SIZE, OR COLOR.

FOR COMPUTER PROGRAMS FOR USE IN ORGANIZING AND EVALUATING DATA FOR THE APPRAISAL OF OIL AND GAS RESERVES AND THE PRODUCTION POTENTIAL OF OIL AND GAS RESERVES (U.S. CLS. 21, 23, 26, 36 AND 38).

FIRST USE 11-0-2010; IN COMMERCE 11-0-2010.

ESTHER BELENKER, EXAMINING ATTORNEY

SN 85-380,116. ENCORE WIRE CORPORATION, MCKINNEY, TX. FILED 7-25-2011.

MC-HCF SMARTGROUND

THE MARK CONSISTS OF STANDARD CHARACTERS WITHOUT CLAIM TO ANY PARTICULAR FONT, STYLE, SIZE, OR COLOR.

OWNER OF U.S. REG. NOS. 3,986,653 AND 3,990,876. FOR ELECTRICAL CABLES; ELECTRICAL WIRES (U.S. CLS. 21, 23, 26, 36 AND 38).

MICHAEL ENGEL, EXAMINING ATTORNEY

CLASS 9—(Continued).

SN 85-381,114. RAFAEL HASAIB, PLANTATION, FL. FILED S.R. 7-26-2011; AM. P.R. 2-2-2012.

Pretty in a Minute

THE MARK CONSISTS OF STANDARD CHARACTERS WITHOUT CLAIM TO ANY PARTICULAR FONT, STYLE, SIZE, OR COLOR.
FOR ELECTRIC HAND-HELD HAIR STYLING IRONS (U.S. CLS. 21, 23, 26, 36 AND 38).
ANDREW LEASER, EXAMINING ATTORNEY

SN 85-382,691. MURALIDHARAN, GAUTAM, EDEN PRAIRIE, MN. FILED 7-27-2011.

Mad Science Labs

THE MARK CONSISTS OF STANDARD CHARACTERS WITHOUT CLAIM TO ANY PARTICULAR FONT, STYLE, SIZE, OR COLOR.
FOR COMPUTER APPLICATION SOFTWARE FOR MOBILE PHONES, NAMELY, SOFTWARE FOR USE IN TEAM COLLABORATION IN PLANNING AND EXECUTING TASKS, AS WELL AS MANAGING PROJECTS WITH A GROUP OF PEOPLE (U.S. CLS. 21, 23, 26, 36 AND 38).
LINDA ORNDORFF, EXAMINING ATTORNEY

SN 85-382,841. BALLY GAMING, INC., DBA BALLY TECHNOLOGIES, LAS VEGAS, NV. FILED 7-27-2011.

HAVANA CUBANA

THE MARK CONSISTS OF STANDARD CHARACTERS WITHOUT CLAIM TO ANY PARTICULAR FONT, STYLE, SIZE, OR COLOR.
THE ENGLISH TRANSLATION OF "HAVANA CUBANA" IN THE MARK IS CUBAN HAVANA.
FOR GAMING MACHINES, NAMELY, DEVICES WHICH ACCEPT A WAGER AND GAMING SOFTWARE THAT GENERATES OR DISPLAYS OUTCOMES FOR GAMING MACHINES (U.S. CLS. 21, 23, 26, 36 AND 38).
BRENDAN REGAN, EXAMINING ATTORNEY

CLASS 9—(Continued).

SN 85-383,078. CYOPTICS, INC., BREINIGSVILLE, PA. FILED 7-28-2011.

CYOPTICS

THE MARK CONSISTS OF STANDARD CHARACTERS WITHOUT CLAIM TO ANY PARTICULAR FONT, STYLE, SIZE, OR COLOR.
FOR INDIUM-PHOSPHIDE (INP)-BASED SEMICONDUCTOR LASERS, DETECTORS AND MODULATORS; SILICA-ON-SILICON INTEGRATED PLANAR LIGHT-GUIDE CIRCUIT (PLC) CHIPS AS A COMPONENT OF OPTICAL ELECTRONICS; OPTICAL COMMUNICATIONS COMPONENTS AND MODULES, NAMELY, OPTICAL TRANSMITTERS, OPTICAL RECEIVERS, OPTICAL TRANSCEIVERS OR OPTICAL TRANSPONDERS; PHOTONICS TECHNOLOGY DEVICES, NAMELY, INTEGRATED INP CHIPS AND SILICA-ON-SILICON PLCS PACKAGED IN TRANSMITTERS, RECEIVERS, TRANSCEIVERS OR TRANSPONDERS (U.S. CLS. 21, 23, 26, 36 AND 38).
FIRST USE 1-1-1999; IN COMMERCE 1-1-1999.
LAURIE MAYES, EXAMINING ATTORNEY

SN 85-388,709. CREDIT UNION NATIONAL ASSOCIATION, INC., MADISON, WI. FILED 8-3-2011.

CREDIT UNION NATIONAL ASSOCIATION

THE MARK CONSISTS OF STANDARD CHARACTERS WITHOUT CLAIM TO ANY PARTICULAR FONT, STYLE, SIZE, OR COLOR.
SEC. 2(F).
FOR DOWNLOADABLE ELECTRONIC NEWSLETTERS IN THE FIELD OF CREDIT UNION BUSINESS, MARKETING AND EDUCATION (U.S. CLS. 21, 23, 26, 36 AND 38).
FIRST USE 5-15-1995; IN COMMERCE 2-0-1998.
ANDREA BUTLER, EXAMINING ATTORNEY

CLASS 9—(Continued).

SN 85-390,534. CROMPTON GREAVES LIMITED, MUMBAI, MAHARASHTRA, INDIA, FILED 8-5-2011.

CG SAGE

THE MARK CONSISTS OF STANDARD CHARACTERS WITHOUT CLAIM TO ANY PARTICULAR FONT, STYLE, SIZE, OR COLOR.

FOR TRANSFORMERS; SWITCHGEARS; REACTORS, NAMELY, ELECTRIC REACTORS, SHUNT REACTORS, SERIES REACTORS; ELECTRICAL RELAYS; CONDENSERS, CAPACITORS; ELECTRICAL TESTING INSTRUMENTS AND APPARATUS, ELECTRICAL DISTRIBUTION PANEL BOARDS; CIRCUIT BREAKERS; ELECTRIC SWITCHES; ELECTRONIC CONTROLLERS; ADAPTER PLUGS; ELECTRICAL SOCKETS; FREQUENCY CHANGERS; METERS, NAMELY, THREE PHASE STATIC TAMPER PROOF WATT HOUR METERS, SINGLE PHASE MULTIFUNCTION TAMPER PROOF WATT HOUR METERS, POWER QUALITY MONITOR, DIGITAL PANEL METER, VOLTMETER, AMMETER H2 AND KWH; FUSES, LOAD BREAK ISOLATORS, ELECTRICAL POWER SUPPLIES, NAMELY, UNINTERRUPTIBLE POWER SUPPLY AND SWITCHED-MODE POWER SUPPLY; INVERTORS, NAMELY, SILENT HOME UNINTERRUPTED POWER SUPPLY (UPS); ELECTRICAL PUSH BUTTON SWITCHES; RECORDED DISC CONTAINING SOFTWARE USED AS A SPREADSHEET IN THE FIELD OF TRANSFORMER AND ELECTRICAL SWITCHGEAR; ELECTRIC FLAT IRONS AND DRY IRONS; ELECTRIC CABLES AND ELECTRIC COILS; ALARMS, NAMELY, FIRE ALARMS; AMPLIFIERS; BATTERIES; CHARGERS, NAMELY, THYRISTOISED BATTERY CHARGERS; TRANSMITTERS OF ELECTRONIC SIGNALS; ELECTRICAL RECEIVERS; ELECTRONIC SIGNAL PROCESSORS; ELECTRIC CONNECTORS; DETECTORS, NAMELY, BEARING TEMPERATURE DETECTORS (RTD), WENDING TEMPERATURE DETECTORS (RTD); COMPUTER SOFTWARE USED FOR AUTOMATED ELEVATOR OPERATING; SCIENTIFIC, ELECTRIC, AND SIGNALING APPARATUS, NAMELY, SIGNALLING RELAYS AND POINT MACHINES FOR TRACK CHANGE IN RAILWAYS; ELECTRICAL TRACTION CONTROLS FOR DIESEL ELECTRIC MULTIPLE UNITS AND TOWER CARS (U.S. CLS. 21, 23, 26, 36 AND 38).

JORDAN BAKER, EXAMINING ATTORNEY

SN 85-391,646. THOMPSON, HAYLEY, HUNTINGTON WOODS, MI. FILED 8-7-2011.

BROOKLYN GIRL MUSIC

THE MARK CONSISTS OF STANDARD CHARACTERS WITHOUT CLAIM TO ANY PARTICULAR FONT, STYLE, SIZE, OR COLOR.

NO CLAIM IS MADE TO THE EXCLUSIVE RIGHT TO USE "MUSIC", APART FROM THE MARK AS SHOWN.

FOR DIGITAL MUSIC DOWNLOADABLE FROM THE INTERNET; AUDIO RECORDINGS FEATURING MUSIC (U.S. CLS. 21, 23, 26, 36 AND 38).

FIRST USE 11-1-2005; IN COMMERCE 11-1-2005.

BERYL GARDNER, EXAMINING ATTORNEY

CLASS 9—(Continued).

SN 85-394,922. IRONCLAD PERFORMANCE WEAR CORP., EL SEGUNDO, CA. FILED 8-10-2011.

AGT

THE MARK CONSISTS OF STANDARD CHARACTERS WITHOUT CLAIM TO ANY PARTICULAR FONT, STYLE, SIZE, OR COLOR.

FOR WORK GLOVE TECHNOLOGY, NAMELY, TEXTILE FABRICS FOR USE IN THE MANUFACTURE OF GLOVES (U.S. CLS. 21, 23, 26, 36 AND 38).

AISHA CLARKE, EXAMINING ATTORNEY

SN 85-395,263. MARTIN, SANDY, DENTON, TX. FILED 8-11-2011.

PSYCHSOFT

When data runs, we catch it

THE MARK CONSISTS OF STANDARD CHARACTERS WITHOUT CLAIM TO ANY PARTICULAR FONT, STYLE, SIZE, OR COLOR.

FOR COMPUTER SOFTWARE FOR USE IN DATA BASE MANAGEMENT IN THE FIELD OF PSYCHOLOGICAL EDUCATIONAL ASSESSMENT (U.S. CLS. 21, 23, 26, 36 AND 38).

FIRST USE 1-1-1994; IN COMMERCE 1-1-1994.

STEVEN R. FINE, EXAMINING ATTORNEY

SN 85-397,763. HONEYWELL INTERNATIONAL INC., MORRISTOWN, NJ. FILED 8-15-2011.

TEMA-VOYAGER

THE MARK CONSISTS OF STANDARD CHARACTERS WITHOUT CLAIM TO ANY PARTICULAR FONT, STYLE, SIZE, OR COLOR.

THE ENGLISH TRANSLATION OF "TEMA" IN THE MARK IS "TOPIC", "THEME".

FOR ELECTRONIC ACCESS CARDS; ELECTRONIC CARD READERS FOR ACCESS CONTROL (U.S. CLS. 21, 23, 26, 36 AND 38).

APRIL ROACH, EXAMINING ATTORNEY

CLASS 9—(Continued).

SN 85-399,209. HEWLETT-PACKARD DEVELOPMENT COMPANY, L.P., HOUSTON, TX. FILED 8-16-2011.

HP TOUCHZONE

THE MARK CONSISTS OF STANDARD CHARACTERS WITHOUT CLAIM TO ANY PARTICULAR FONT, STYLE, SIZE, OR COLOR.

OWNER OF U.S. REG. NOS. 1,840,215, 3,600,880 AND OTHERS.

FOR EQUIPMENT AND ACCESSORIES FOR MOBILE COMMUNICATIONS DEVICES; TABLETS; MOBILE PHONES AND SMARTPHONES; NAMELY, BATTERY CHARGING DEVICES; BATTERY CHARGING DOCKS; APPARATUS FOR RECORDING, TRANSMISSION, SYNCHRONIZATION, OR REPRODUCTION OF DATA, TEXT, GRAPHICS, SOUND OR IMAGES; POWER SUPPLIES AND POWER MANAGEMENT EQUIPMENT FOR MOBILE COMMUNICATION DEVICES; NAMELY, BATTERY CHARGERS, CONNECTORS, ADAPTERS, AND CABLES, ALL FOR TABLET COMPUTERS, MOBILE TELEPHONES AND SMARTPHONES; WIRELESS NETWORK TECHNOLOGY THAT ALLOWS MOBILE COMMUNICATION DEVICES, NAMELY, COMPUTERS, SMARTPHONES, MOBILE PHONES, AND HAND-HELD COMPUTER DEVICES TO EXCHANGE DATA BY TAPPING SUCH MOBILE COMMUNICATION DEVICES WITH EACH OTHER AND OTHER SUITABLY ENABLED DEVICES; BATTERY CHARGERS FOR MOBILE COMMUNICATION DEVICES; BLANK MAGNETIC DATA CARRIERS AND BLANK RECORDABLE OPTICAL DISCS; DATA PROCESSING EQUIPMENT; COMPUTERS; COMPUTER HARDWARE; MOBILE COMPUTERS; HANDHELD COMPUTERS; TABLET COMPUTERS; COMPUTER PERIPHERALS; COMPUTER MONITORS; COMPUTER KEYBOARDS; COMMUNICATIONS SERVER HARDWARE; COMPUTER HARDWARE FOR TELECOMMUNICATIONS; TELEPHONES; MOBILE TELEPHONES; SMARTPHONES; MOBILE AND HAND-HELD WIRELESS COMMUNICATION DEVICE FEATURING VOICE, DATA AND IMAGE TRANSMISSION INCLUDING VOICE AND TEXT; COMPUTER SOFTWARE THAT ALLOWS THAT ALLOWS MOBILE COMMUNICATION DEVICES, NAMELY, COMPUTERS, SMARTPHONES, MOBILE PHONES, AND HAND-HELD COMPUTER DEVICES TO EXCHANGE DATA BY TAPPING SUCH MOBILE COMMUNICATION DEVICES WITH EACH OTHER AND OTHER SUITABLY ENABLED DEVICES; COMPUTER SOFTWARE, NAMELY, COMPUTER COMMUNICATIONS SOFTWARE FOR CONNECTING COMPUTER NETWORK USERS; COMPUTER SOFTWARE, NAMELY, PRERECORDED COMPUTER PROGRAMS FOR PERSONAL INFORMATION MANAGEMENT, OPTICAL CHARACTER RECOGNITION SOFTWARE, TELECOMMUNICATIONS SOFTWARE FOR ENABLING COMMUNICATION BETWEEN USERS OF MOBILE COMMUNICATION DEVICES, MOBILE PHONES AND SMARTPHONES, TELEPHONY MANAGEMENT SOFTWARE, COMPUTER DATABASE MANAGEMENT SOFTWARE FOR USE IN PERSONALIZING THE CONTENT OF E-MAIL AND MESSAGING COMMUNICATIONS, COMPUTER COMMUNICATIONS SOFTWARE FOR SENDING AND MANAGING PAGER MESSAGES, DATABASE SYNCHRONIZATION SOFTWARE, COMPUTER PROGRAMS FOR ACCESSING, BROWSING AND SEARCHING ONLINE DATABASES; INSTRUCTION MANUALS IN ELECTRONIC FORM SOLD AS A UNIT WITH THE FOREGOING (U.S. CLS. 21, 23, 26, 36 AND 38).

LAURIE MAYES, EXAMINING ATTORNEY

CLASS 9—(Continued).

SN 85-412,997. PIGNOTTI, CHRISTOPHER S., PHOENIX, AZ. FILED 9-1-2011.

ACCUTOWER

THE MARK CONSISTS OF STANDARD CHARACTERS WITHOUT CLAIM TO ANY PARTICULAR FONT, STYLE, SIZE, OR COLOR.

FOR COMPACT DISC WRITERS; UNIVERSAL SERIAL BUS COPIERS; DIGITAL VIDEO DISC WRITERS; MULTIMEDIA DISC DUPLICATOR HARDWARE, NAMELY, COMPUTER HARDWARE FOR COPYING MEMORY CARDS (U.S. CLS. 21, 23, 26, 36 AND 38).

FIRST USE 0-0-2000; IN COMMERCE 0-0-2000.
THOMAS MANOR, EXAMINING ATTORNEY

SN 85-416,248. ATG CEYLON (PVT) LIMITED, IPZ, KATUNAYAKE, SRI LANKA, FILED 9-7-2011.

MAXICHEM

THE MARK CONSISTS OF STANDARD CHARACTERS WITHOUT CLAIM TO ANY PARTICULAR FONT, STYLE, SIZE, OR COLOR.

FOR SAFETY GLOVES; INDUSTRIAL SAFETY GLOVES (U.S. CLS. 21, 23, 26, 36 AND 38).

MATTHEW PAPPAS, EXAMINING ATTORNEY

SN 85-416,384. POSTURECO, INC., NEW PORT RICHEY, FL. FILED 9-7-2011.

PostureScreen
The Ultimate in Express Postural Assessment *Mobile*



NO CLAIM IS MADE TO THE EXCLUSIVE RIGHT TO USE "MOBILE" AND "POSTURAL ASSESSMENT", APART FROM THE MARK AS SHOWN.

THE MARK CONSISTS OF 3 DOTS IN AN ASCENDING FORM FROM LEFT TO RIGHT, THE TEXT "POSTURESCREEN" ON THE RIGHT OF THE DOTS, THE TEXT "THE ULTIMATE IN EXPRESS POSTURAL ASSESSMENT MOBILE" BELOW "POSTURESCREEN", AND AN IMAGE OF AN INDIVIDUAL CENTERED IN A SQUARE WITH ROUNDED EDGES, BELOW "THE ULTIMATE IN EXPRESS POSTURAL ASSESSMENT MOBILE".

FOR COMPUTER APPLICATION SOFTWARE FOR MOBILE PHONES, PORTABLE MEDIA PLAYERS, AND HANDHELD COMPUTING DEVICES, NAMELY, SOFTWARE FOR POSTURE ANALYSIS (U.S. CLS. 21, 23, 26, 36 AND 38).

VIVIAN MICZNIK FIRST, EXAMINING ATTORNEY

CLASS 9—(Continued).

SN 85-422,209. WHEATSTONE CORPORATION, NEW BERN, NC. FILED 9-14-2011.

AUDIOARTS ENGINEERING

NO CLAIM IS MADE TO THE EXCLUSIVE RIGHT TO USE THE DESIGN REPRESENTATION OF A PRINTED CIRCUIT CARD DETAIL AND "ENGINEERING", APART FROM THE MARK AS SHOWN.

THE MARK CONSISTS OF A DESIGN REPRESENTATION OF A PRINTED CIRCUIT CARD WITH THE WORDS "AUDIOARTS ENGINEERING" TO THE RIGHT OF THE DESIGN.

FOR AUDIO ELECTRONIC EQUIPMENT, COMPRISING PARAMETRIC EQUALIZERS, TUNEABLE ELECTRONIC CROSSOVERS, FEEDBACK SUPPRESSORS, STEREO MIXER PREAMPLIFIERS, AND MULTIPLE CHANNEL RECORDING CONSOLES; ELECTRONIC AND COMPUTER CIRCUITS, CIRCUIT BOARDS, HARDWARE AND SOFTWARE FOR THE CONTROL, PROCESSING AND DISTRIBUTION OF MULTIPLE DIGITAL AND ANALOG AUDIO AND DATA SIGNALS BOTH LOCALLY AND OVER EXTENDED AREA DIGITAL COMPUTER NETWORKS (U.S. CLS. 21, 23, 26, 36 AND 38).

FIRST USE 12-15-2000; IN COMMERCE 12-15-2000.
MATTHEW MCDOWELL, EXAMINING ATTORNEY

SN 85-422,226. WITEC WISSENSCHAFTLICHE INSTRUMENTE UND TECHNOLOGIE GMBH, ULM, FED REP GERMANY, FILED 9-14-2011.

TrueSurface

THE MARK CONSISTS OF STANDARD CHARACTERS WITHOUT CLAIM TO ANY PARTICULAR FONT, STYLE, SIZE, OR COLOR.

FOR SCIENTIFIC INSTRUMENTS, NAMELY, MICROSCOPES, OPTICAL MICROSCOPES, SCANNING PROBE MICROSCOPES (U.S. CLS. 21, 23, 26, 36 AND 38).

FIRST USE 12-8-2010; IN COMMERCE 12-8-2010.
NAPOLEON SHARMA, EXAMINING ATTORNEY

CLASS 9—(Continued).

SN 85-422,423. FREMANTLEMEDIA LIMITED, LONDON, ENGLAND, FILED 9-14-2011.

TREE FU TOM

THE MARK CONSISTS OF STANDARD CHARACTERS WITHOUT CLAIM TO ANY PARTICULAR FONT, STYLE, SIZE, OR COLOR.

PRIORITY CLAIMED UNDER SEC. 44(D) ON ERP N CMNTY TM OFC APPLICATION NO. 009871443, FILED 4-6-2011, REG. NO. 009871443, DATED 8-22-2011, EXPIRES 4-6-2021.

FOR CINEMATOGRAPHIC FILMS FEATURING MUSIC, SOUNDTRACKS, ARTISTIC PERFORMANCES, DOCUMENTARIES, DRAMAS, COMEDIES, AND ANIMATION; EXPOSED CINEMATOGRAPHIC FILMS; ANIMATED CARTOONS RECORDED ON VIDEO DISCS AND VIDEO TAPES; MAGNETIC RECORDINGS NAMELY, VIDEO CASSETTES, PRE-RECORDED CD-ROM, PRE-RECORDED DVD, PRE-RECORDED HIGH DEFINITION VIDEO CASSETTES, PRE-RECORDED HD-DVD, PRE-RECORDED COMPUTER DISCS, AND PRE-RECORDED LASERDISCS FEATURING MUSIC, DOCUMENTARIES, DRAMAS, COMEDIES, ANIMATIONS, AND CARTOONS; MAGNETO-OPTICAL RECORDINGS, NAMELY, PRE-RECORDED DVDS AND COMPACT DISCS FEATURING MUSIC, DOCUMENTARIES, DRAMAS, AND COMEDIES; SOLID-STATE RECORDINGS, NAMELY, PRE-RECORDED FLASH MEMORY CARDS FEATURING MUSIC, DOCUMENTARIES, DRAMAS, ANIMATIONS, AND COMEDIES; AMUSEMENT APPARATUS, NAMELY, VIDEO GAME MACHINES ADAPTED FOR USE WITH TELEVISION RECEIVERS; ELECTRONIC BOOKS AND ELECTRONIC DOWNLOADABLE PUBLICATIONS IN THE NATURE OF BOOKS AND MAGAZINES, ALL FEATURING A CHILDREN'S ANIMATION SERIES; ELECTRONIC GAMES ADAPTED FOR USE WITH TELEVISION RECEIVERS ONLY; INTERACTIVE GAMES ADAPTED FOR USE WITH TELEVISION RECEIVERS; ELECTRICAL AND VIDEO AMUSEMENT APPARATUS AND INSTRUMENTS, NAMELY, VIDEO GAME MACHINES ADAPTED FOR USE WITH TELEVISION RECEIVERS; AUDIO TAPES FEATURING MUSIC, SOUNDTRACKS, ARTISTIC PERFORMANCES, DOCUMENTARIES, DRAMAS, COMEDIES, AND ANIMATION; VIDEO TAPES FEATURING MUSIC, SOUNDTRACKS, ARTISTIC PERFORMANCES, DOCUMENTARIES, DRAMAS, COMEDIES, AND ANIMATION; LASER DISCS FEATURING MUSIC, SOUNDTRACKS, ARTISTIC PERFORMANCES, DOCUMENTARIES, DRAMAS, COMEDIES, AND ANIMATION; COMPACT DISCS-INTERACTIVE CD ROMS FEATURING MUSIC, SOUNDTRACKS, ARTISTIC PERFORMANCES, DOCUMENTARIES, DRAMAS, COMEDIES AND ANIMATION; DIGITAL VIDEO DISCS (DVD) FEATURING MUSIC, SOUNDTRACKS, ARTISTIC PERFORMANCES, DOCUMENTARIES, DRAMAS, COMEDIES, AND ANIMATION; MOBILE PHONE GAMES NAMELY, COMPUTER GAME SOFTWARE FOR USE ON MOBILE PHONES; KARAOKE MACHINES; DIGITAL GAMES AND MOBILE PHONE GAMES, ALL BEING COMPUTER GAME SOFTWARE; DVD GAMES (U.S. CLS. 21, 23, 26, 36 AND 38).

MARK RADEMACHER, EXAMINING ATTORNEY

CLASS 9—(Continued).

SN 85-424,410. SIRCHIE ACQUISITION COMPANY, LLC, YOUNGSVILLE, NC. FILED 9-16-2011.

LABKAM

THE MARK CONSISTS OF STANDARD CHARACTERS WITHOUT CLAIM TO ANY PARTICULAR FONT, STYLE, SIZE, OR COLOR.

FOR ULTRAVIOLET IMAGING APPARATUS FOR SCANNING EVIDENCE AND CAPTURING LATENT FINGERPRINTS IN THE NATURE OF A DIGITAL VIDEO SYSTEM AND EMBEDDED SOFTWARE (U.S. CLS. 21, 23, 26, 36 AND 38).

FIRST USE 2-24-2011; IN COMMERCE 2-24-2011.
ALLISON HOLTZ, EXAMINING ATTORNEY

CLASS 9—(Continued).

SN 85-429,072. ANCHONDO, ALDO, COLORADO SPRINGS, CO. AND ANCHONDO, DANIEL, COLORADO SPRINGS, CO. AND ANCHONDO, LEONEL, COLORADO SPRINGS, CO. FILED 9-22-2011.

D'vociion Productions

THE MARK CONSISTS OF STANDARD CHARACTERS WITHOUT CLAIM TO ANY PARTICULAR FONT, STYLE, SIZE, OR COLOR.

NO CLAIM IS MADE TO THE EXCLUSIVE RIGHT TO USE "PRODUCTIONS", APART FROM THE MARK AS SHOWN.

THE TERM "D'VOCION" HAS NO MEANING IN A FOREIGN LANGUAGE.

FOR AUDIO AND VIDEO RECORDINGS FEATURING MUSIC; DIGITAL MEDIA, NAMELY, DOWNLOADABLE AUDIO FILES, CDS, DVDS, CD-ROMS, AND CARTRIDGES FEATURING MUSIC (U.S. CLS. 21, 23, 26, 36 AND 38).

FIRST USE 2-23-2011; IN COMMERCE 4-10-2011.
EVELYN BRADLEY, EXAMINING ATTORNEY

SN 85-428,512. BIONIC TRADER SYSTEMS, LLC, CHICAGO, IL. FILED 9-21-2011.



THE MARK CONSISTS OF A CUSTOM DESIGN RESEMBLING A KEY FROM A COMPUTER KEYBOARD WITH A SOLID TOP AND A MAZE DESIGN SHOWN ON TWO SIDES.

FOR COMPUTER SOFTWARE PROGRAMS AND COMPUTER HARDWARE FOR TRADING FUTURES, COMMODITIES, STOCKS, BONDS, OPTIONS, FOREX, CURRENCY, FIXED INCOME INSTRUMENTS, EXCHANGE-TRADED FUNDS, CREDIT INSTRUMENTS, INTEREST-RATE INSTRUMENTS, INDEX FUNDS, SWAPS, AND DERIVATIVES (U.S. CLS. 21, 23, 26, 36 AND 38).

MATTHEW KLINE, EXAMINING ATTORNEY

SN 85-429,413. MCGREGOR, FRASER T, TORONTO, CANADA, FILED 9-22-2011.

Frazer

THE MARK CONSISTS OF STANDARD CHARACTERS WITHOUT CLAIM TO ANY PARTICULAR FONT, STYLE, SIZE, OR COLOR.

THE NAME(S), PORTRAIT(S), AND/OR SIGNATURE(S) SHOWN IN THE MARK IDENTIFIES "FRASER T. MCGREGOR", WHOSE CONSENT(S) TO REGISTER IS MADE OF RECORD.

FOR AUDIO TAPES FEATURING MUSIC; DIGITAL MUSIC DOWNLOADABLE FROM THE INTERNET; DOWNLOADABLE MUSICAL SOUND RECORDINGS; DOWNLOADABLE RING TONES AND MUSIC VIA A GLOBAL COMPUTER NETWORK AND WIRELESS DEVICES; DOWNLOADABLE VIDEO RECORDINGS FEATURING MUSIC; PHONOGRAPH RECORDS FEATURING MUSIC; PRERECORDED AUDIO TAPES FEATURING MUSIC; PRERECORDED VIDEO CASSETTES FEATURING MUSIC; PRERECORDED VIDEO TAPES FEATURING MUSIC; SOUND RECORDINGS FEATURING MUSIC (U.S. CLS. 21, 23, 26, 36 AND 38).

FIRST USE 9-19-2009; IN COMMERCE 9-19-2009.
SIMON TENG, EXAMINING ATTORNEY

CLASS 9—(Continued).

SN 85-430,083. WALTER T. FRANCIS, STAFFORD, VA. FILED 9-23-2011.



NO CLAIM IS MADE TO THE EXCLUSIVE RIGHT TO USE "PENCIL CLIP", APART FROM THE MARK AS SHOWN.

THE MARK CONSISTS OF A CIRCULAR RING FORMED BY INNER AND OUTER LINES THAT FORM ALMOST A COMPLETE CIRCLE. BETWEEN WHICH LINES APPEARS THE WORDING "PENCIL - CLIP", AND WITH THE INNER CIRCULAR LINE HAVING DISPLAYED WITHIN THE CIRCLE WHICH IT FORMS A DRAWING OF A TAPE MEASURE HAVING A BRACKET END, WITH SAID BRACKET END EXTENDING OUTWARDLY OF BOTH THE INTERIOR-LINE AND EXTERIOR-LINE CIRCLES, AND WITH SAID BRACKET END HAVING ON ITS FRONT FACE A SOLID BLACK LETTER "A" AND A ROUNDED RECTANGLE.

FOR MEASURING DEVICES, NAMELY, TAPE MEASURES HAVING AN END PIECE FOR MARKING LOCATION (U.S. CLS. 21, 23, 26, 36 AND 38).

KATHLEEN KOLACZ, EXAMINING ATTORNEY

SN 85-431,289. PUMP YOU UP, INC., KELLER, TX. FILED 9-24-2011.

PumpYouUp

THE MARK CONSISTS OF STANDARD CHARACTERS WITHOUT CLAIM TO ANY PARTICULAR FONT, STYLE, SIZE, OR COLOR.

FOR AUDIO AND VIDEO RECORDINGS FEATURING MUSIC AND ARTISTIC PERFORMANCES (U.S. CLS. 21, 23, 26, 36 AND 38).

FIRST USE 7-6-2004; IN COMMERCE 7-6-2004.

TIMOTHY FINNEGAN, EXAMINING ATTORNEY

CLASS 9—(Continued).

SN 85-431,585. TENSOR ID, INC., TEMECULA, CA. FILED 9-26-2011.

ID THIS

THE MARK CONSISTS OF STANDARD CHARACTERS WITHOUT CLAIM TO ANY PARTICULAR FONT, STYLE, SIZE, OR COLOR.

NO CLAIM IS MADE TO THE EXCLUSIVE RIGHT TO USE "ID", APART FROM THE MARK AS SHOWN.

FOR BARCODE SCANNERS (U.S. CLS. 21, 23, 26, 36 AND 38).

CURTIS FRENCH, EXAMINING ATTORNEY

SN 85-431,884. WMS GAMING INC., WAUKEGAN, IL. FILED 9-26-2011.

PRIME REEL ESTATE

THE MARK CONSISTS OF STANDARD CHARACTERS WITHOUT CLAIM TO ANY PARTICULAR FONT, STYLE, SIZE, OR COLOR.

OWNER OF U.S. REG. NOS. 2,319,796 AND 3,570,506.

FOR COMPONENTS FOR GAMING MACHINES THAT GENERATE OR DISPLAY WAGER OUTCOMES, NAMELY, CONTROLLERS, DISPLAYS, BUTTON PANELS, BOLSTERS, ELECTRICAL WIRING, AND COMPUTER HARDWARE AND SOFTWARE ASSOCIATED THEREWITH; GAMING MACHINES, NAMELY, DEVICES WHICH ACCEPT A WAGER; GAMING SOFTWARE THAT GENERATES OR DISPLAYS WAGER OUTCOMES OF GAMING MACHINES (U.S. CLS. 21, 23, 26, 36 AND 38).

DEBORAH LOBO, EXAMINING ATTORNEY

SN 85-432,643. NANOINJECTION TECHNOLOGIES LLC, SALT LAKE CITY, UT. FILED 9-27-2011.

ERAS

THE MARK CONSISTS OF STANDARD CHARACTERS WITHOUT CLAIM TO ANY PARTICULAR FONT, STYLE, SIZE, OR COLOR.

FOR SCIENTIFIC APPARATUS AND INSTRUMENTS FOR SCIENTIFIC RESEARCH IN LABORATORIES, NAMELY, AN EMBRYO RESTRAINT AND ALIGNMENT DEVICE FOR USE IN CONNECTION WITH THE MANIPULATION, RESTRAINT AND INJECTION OF EMBRYOS (U.S. CLS. 21, 23, 26, 36 AND 38).

EMILY CHUO, EXAMINING ATTORNEY

CLASS 9—(Continued).

SN 85-432,692. MIMOCO, INC., BOSTON, MA. FILED 9-27-2011.

MimoMicro

THE MARK CONSISTS OF STANDARD CHARACTERS WITHOUT CLAIM TO ANY PARTICULAR FONT, STYLE, SIZE, OR COLOR.

OWNER OF U.S. REG. NOS. 3,140,381, 3,985,585 AND 3,985,587.

FOR COMPUTER HARDWARE AND PERIPHERALS; COMPUTER MEMORY HARDWARE; COMPUTER SOFTWARE PROGRAMS FOR THE INTEGRATION OF MUSIC, TEXT, STILL IMAGES, ANIMATION OR INTERACTIVE GAMES INTO AN INTERACTIVE DELIVERY FOR MULTIMEDIA ENTERTAINMENT APPLICATIONS (U.S. CLS. 21, 23, 26, 36 AND 38).

JASON BLAIR, EXAMINING ATTORNEY

SN 85-433,920. SUNSASSY, LLC, LEWISVILLE, TX. FILED 9-28-2011.

SNAILS

THE MARK CONSISTS OF STANDARD CHARACTERS WITHOUT CLAIM TO ANY PARTICULAR FONT, STYLE, SIZE, OR COLOR.

FOR EYEGLASS FRAMES (U.S. CLS. 21, 23, 26, 36 AND 38).

BRENDAN MCCAULEY, EXAMINING ATTORNEY

SN 85-433,981. ACE SALES & SERVICES CORPORATION, HOUSTON, TX. FILED 9-28-2011.

LIZARD TRADING SOFTWARE

THE MARK CONSISTS OF STANDARD CHARACTERS WITHOUT CLAIM TO ANY PARTICULAR FONT, STYLE, SIZE, OR COLOR.

NO CLAIM IS MADE TO THE EXCLUSIVE RIGHT TO USE "TRADING SOFTWARE", APART FROM THE MARK AS SHOWN.

FOR COMPUTER PROGRAMS AND COMPUTER SOFTWARE FOR ELECTRONIC STOCK MARKET TRADING (U.S. CLS. 21, 23, 26, 36 AND 38).

FIRST USE 6-1-2007; IN COMMERCE 9-1-2008.
KIMBERLY FRYE, EXAMINING ATTORNEY

CLASS 9—(Continued).

SN 85-435,116. VPI ENGINEERING, INC., DRAPER, UT. FILED 9-29-2011.

Rad-IDX

THE MARK CONSISTS OF STANDARD CHARACTERS WITHOUT CLAIM TO ANY PARTICULAR FONT, STYLE, SIZE, OR COLOR.

OWNER OF U.S. REG. NO. 2,938,796.
FOR RADIATION DETECTORS (U.S. CLS. 21, 23, 26, 36 AND 38).

SUSAN LESLIE DUBOIS, EXAMINING ATTORNEY

SN 85-435,202. NIPPON DENKI KABUSHIKI KAISHA, DBA NEC CORPORATION, TOKYO, JAPAN, FILED 9-29-2011.



The logo for e-Pathologist features the word "e-Pathologist" in a bold, sans-serif font. The letter "e" is stylized with a blue dot and a yellow dot. The word "Pathologist" is in black. There is a small blue and yellow graphic element to the left of the "e".

NO CLAIM IS MADE TO THE EXCLUSIVE RIGHT TO USE "E-PATHOLOGIST", APART FROM THE MARK AS SHOWN.

THE COLOR(S) BLUE, YELLOW, RED AND BLACK IS/ARE CLAIMED AS A FEATURE OF THE MARK.

THE MARK CONSISTS OF THE STYLIZED WORD "E-PATHOLOGIST" WITH THE LETTER "E" IN THE COLOR BLUE AND THE WORD "-PATHOLOGIST" IN THE COLOR BLACK WITH BLUE, YELLOW AND RED SQUARES.

FOR COMPUTER SOFTWARE AND HARDWARE FOR USE IN AUTOMATED ACQUISITION AND ANALYSIS OF IMAGES OF HUMAN AND ANIMAL CELLS AND TISSUES FOR MEDICAL DIAGNOSIS AND PATHOLOGY; CLINICAL ASSESSMENT COMPUTER SOFTWARE; COMPUTER SOFTWARE FOR CANCER DIAGNOSIS SUPPORT SYSTEM (U.S. CLS. 21, 23, 26, 36 AND 38).

JOHN DWYER, EXAMINING ATTORNEY

CLASS 9—(Continued).

SN 85-435,527. ORCHESTRATORMAIL, INC., FORMERLY ORCHESTRATORMAIL, SAN FRANCISCO, CA. FILED 9-29-2011.

CLASS 9—(Continued).

SN 85-436,933. TORION TECHNOLOGIES, INC., AMERICAN FORK, UT. FILED 9-30-2011.



CHROMION

THE COLOR(S) ORANGE AND WHITE IS/ARE CLAIMED AS A FEATURE OF THE MARK.

THE MARK CONSISTS OF THE LETTER "O" AND A SUPERSCRIPIT LETTER "M" IN WHITE ON AN ORANGE SQUARE.

FOR COMPUTER APPLICATION SOFTWARE FOR MOBILE PHONES, NAMELY, SOFTWARE FOR CREATING NEW STRUCTURED EMAIL MESSAGES; COMPUTER DATABASE MANAGEMENT SOFTWARE FOR USE IN PERSONALIZING THE CONTENT OF E-MAIL COMMUNICATIONS; COMPUTER SOFTWARE FOR APPLICATION AND DATABASE INTEGRATION; COMPUTER SOFTWARE FOR THE COLLECTION, EDITING, ORGANIZING, MODIFYING, BOOK MARKING, TRANSMISSION, STORAGE AND SHARING OF DATA AND INFORMATION; COMPUTER SOFTWARE FOR USE IN CUSTOMER RELATIONSHIP MANAGEMENT (CRM); COMPUTER SOFTWARE PLATFORMS FOR COORDINATING WITH OTHERS; COMPUTER SOFTWARE THAT PROVIDES WEB-BASED ACCESS TO APPLICATIONS AND SERVICES THROUGH A WEB OPERATING SYSTEM OR PORTAL INTERFACE; DOWNLOADABLE SOFTWARE FOR DESKTOP TO COORDINATE WITH THE HOSTED SERVER APPLICATION; DOWNLOADABLE SOFTWARE IN THE NATURE OF A MOBILE APPLICATION FOR COORDINATING WITH HOSTED SERVER APPLICATION (U.S. CLS. 21, 23, 26, 36 AND 38).

FIRST USE 6-1-2010; IN COMMERCE 2-14-2011.

TOBY BULLOFF, EXAMINING ATTORNEY

THE MARK CONSISTS OF STANDARD CHARACTERS WITHOUT CLAIM TO ANY PARTICULAR FONT, STYLE, SIZE, OR COLOR.

FOR COMPUTER SOFTWARE FOR ANALYZING DATA FROM SCIENTIFIC ANALYSIS OF CHEMICAL COMPOUNDS; COMPUTER SOFTWARE FOR ANALYZING DATA FROM CHROMATOGRAPHIC ANALYSIS OF CHEMICAL COMPOUNDS; COMPUTER SOFTWARE FOR ANALYZING DATA FROM GAS CHROMATOGRAPHIC ANALYSIS OF CHEMICAL COMPOUNDS; COMPUTER SOFTWARE FOR IDENTIFYING CHEMICAL COMPOUNDS FROM DATA OBTAINED BY CHROMATOGRAPHIC ANALYSIS; COMPUTER SOFTWARE FOR IDENTIFYING CHEMICAL COMPOUNDS FROM DATA OBTAINED BY GAS CHROMATOGRAPHY; ALL OF THE FOREGOING SOLD AS A COMPONENT PART OF PORTABLE CHROMATOGRAPHS AND/OR MASS SPECTROMETERS; COMPUTER SOFTWARE FOR ANALYZING DATA FROM SCIENTIFIC ANALYSIS OF CHEMICAL COMPOUNDS; COMPUTER SOFTWARE FOR ANALYZING DATA FROM CHROMATOGRAPHIC ANALYSIS OF CHEMICAL COMPOUNDS; COMPUTER SOFTWARE FOR ANALYZING DATA FROM GAS CHROMATOGRAPHIC ANALYSIS OF CHEMICAL COMPOUNDS; COMPUTER SOFTWARE FOR IDENTIFYING CHEMICAL COMPOUNDS FROM DATA OBTAINED BY CHROMATOGRAPHIC ANALYSIS; COMPUTER SOFTWARE FOR IDENTIFYING CHEMICAL COMPOUNDS FROM DATA OBTAINED BY GAS CHROMATOGRAPHY; ALL OF THE FOREGOING SOFTWARE PRODUCTS ARE FOR USE IN DETECTING ORGANIC COMPOUNDS AND ARE NOT FOR USE IN DETECTING NON-ORGANIC COMPOUNDS (U.S. CLS. 21, 23, 26, 36 AND 38).

FIRST USE 8-29-2009; IN COMMERCE 8-29-2009.

MEGHAN REINHART, EXAMINING ATTORNEY

CLASS 9—(Continued).

SN 85-437,063. LIMMER, JAMES B, ADELAIDE, SA, AUSTRALIA, FILED 9-30-2011.

Mindfuse

PRIORITY CLAIMED UNDER SEC. 44(D) ON AUSTRALIA APPLICATION NO. 15322392, FILED 9-19-2011.

FOR COMPUTER SOFTWARE FOR INTERPRETATION OF NEURO AND BRAIN SCANS PROVIDED BY DIAGNOSTIC IMAGING EQUIPMENT; ELECTRIC OR ELECTRONIC SENSORS FOR NEUROFEEDBACK; ELECTRIC SENSORS; ELECTRICAL SENSOR APPARATUS FOR SENSING THE PRESENCE OR ABSENCE OF INDIVIDUALS OR OBJECTS BY CONTACT OR PRESSURE; ELECTRONIC DATA RELAYS FOR SENSORS; ELECTRONIC MAGNETOSTRICTIVE EQUIPMENT, NAMELY, A WAVE GENERATOR, WAVE SENSOR AND WAVE ANALYZER; MICROSENSORS FOR MEASUREMENT OF PRESSURE, ACCELERATION, FORCE AND FLOW, NAMELY, SILICON PIEZORESISTIVE PRESSURE SENSORS; SENSOR CHIPS FOR SCIENTIFIC USE; SENSORS AND DETECTOR UNITS FOR USE IN CONTROLLING THE ACTUATION AND OPERATION OF AUTOMOTIVE SAFETY APPARATUS AND EQUIPMENT; SENSORS FOR DETERMINING POSITION, VELOCITY, ACCELERATION AND TEMPERATURE; SENSORS FOR THE DETERMINATION OF TEMPERATURES, POSITIONS AND DISTANCES; TELECOMMUNICATIONS EQUIPMENT, NAMELY, FIBER-OPTIC TRANSCIEVERS, FIBER OPTIC REPEATERS, CONVERTERS AND OPTIMIZERS, WAVE DIVISION MULTIPLEXERS, FREE-SPACE OPTICS TRANSMISSION SYSTEMS, SWITCHES INCLUDING ETHERNET SWITCHES AND ROUTERS, FIBER-TO-THE-HOME AND ETHERNET-OVER-VDSL ACCESS AGGREGATORS, TERMINATORS AND REPEATERS, AND REMOTE PRESENCE MANAGEMENT PRODUCTS, NAMELY, SWITCHES, AND CONSOLE, ALARM, SENSOR AND POWER MANAGEMENT DEVICES; TELECOMMUNICATIONS HARDWARE AND SOFTWARE FOR MONITORING AND ALERTING REMOTE SENSOR STATUS VIA THE INTERNET; TEMPERATURE SENSORS USED IN THE MEDICAL FIELD TO MEASURE TEMPERATURE OF MEDICAL SOLUTIONS; TIMING SENSORS; ULTRASONIC SENSORS (U.S. CLS. 21, 23, 26, 36 AND 38).

MYRIAH HABEEB, EXAMINING ATTORNEY

SN 85-439,351. FRONTLINE PCB SOLUTIONS LTD, YAVNE, ISRAEL, FILED 10-5-2011.

InSolver

THE MARK CONSISTS OF STANDARD CHARACTERS WITHOUT CLAIM TO ANY PARTICULAR FONT, STYLE, SIZE, OR COLOR.

FOR COMPUTER SOFTWARE THAT CALCULATES SIGNAL INTEGRITY CHARACTERISTICS FOR THE PCB (PRINTED CIRCUIT BOARDS) INDUSTRY (U.S. CLS. 21, 23, 26, 36 AND 38).

JANICE KIM, EXAMINING ATTORNEY

CLASS 9—(Continued).

SN 85-440,120. SAINT-GOBAIN CERAMICS & PLASTICS, INC., WORCESTER, MA. FILED 10-5-2011.

HEXOLOY

THE MARK CONSISTS OF STANDARD CHARACTERS WITHOUT CLAIM TO ANY PARTICULAR FONT, STYLE, SIZE, OR COLOR.

OWNER OF U.S. REG. NO. 1,388,802.

FOR CERAMIC ARMOR FOR PROTECTING THE BODY, VEHICLES AND AIRCRAFT AGAINST BALLISTIC PROJECTILES (U.S. CLS. 21, 23, 26, 36 AND 38).

FIRST USE 0-0-1988; IN COMMERCE 0-0-1988.

LINDA M. KING, EXAMINING ATTORNEY

SN 85-440,394. DURGA PRASAD PANGA, TONAWANDA, NY. FILED 10-6-2011.



The logo for iFacets features a stylized 'i' composed of four overlapping squares in light blue, green, orange, and white. To the right of the 'i' is the word 'Facets' in a bold, dark blue, sans-serif font.

THE COLOR(S) LIGHT BLUE, DARK BLUE, GREEN, ORANGE AND WHITE IS/ARE CLAIMED AS A FEATURE OF THE MARK.

THE MARK CONSISTS OF THE STYLIZED WORDING "IFACETS" WITH THE LETTER "I" IN LIGHT BLUE AND THE REST OF THE WORD IN DARK BLUE. TO THE LEFT OF THE WORDING IS AN ABSTRACT DESIGN OF THE OVERLAPPING LETTERS "IF" FORMED BY TWO RECTANGLES AND THREE PARALLELOGRAMS. THE TOP LEFT PARALLELOGRAM IS LIGHT BLUE WITH A WHITE, SEVEN-POINTED STAR; BELOW IT IS A GREEN RECTANGLE, AND BELOW THAT IS AN ORANGE PARALLELOGRAM. THE TOP RIGHT PARALLELOGRAM IS GREEN AND BELOW IT IS AN ORANGE RECTANGLE. ALL TOGETHER, THE SHAPES FORM A STYLIZED LETTER "F" AND THE LEFT SIDE OF THE "F" APPEARS AS THE LETTER "I".

FOR DOWNLOADABLE COMPUTER SOFTWARE FOR THE DESIGN, CREATION, MAINTENANCE, INTEGRATION, PUBLICATION AND MANAGEMENT OF WEBSITES WITH ELECTRONIC DATA AND CONTENT IN ANY FORMAT LIKE TEXT, DOCUMENTS, IMAGES, AUDIO, VIDEO, GRAPHS, GEOGRAPHICAL, STATIC OR REAL TIME FOR USE ON INTERNET OR INTRANET (U.S. CLS. 21, 23, 26, 36 AND 38).

JAMES GRIFFIN, EXAMINING ATTORNEY

CLASS 9—(Continued).

SN 85-442,047. ARMORWORKS ENTERPRISES, LLC, CHANDLER, AZ. FILED 10-7-2011.

SHOCKSAFE

THE MARK CONSISTS OF STANDARD CHARACTERS WITHOUT CLAIM TO ANY PARTICULAR FONT, STYLE, SIZE, OR COLOR.

FOR PROTECTIVE BALLISTIC RESISTANT AND MITIGATING AND BLAST RESISTANT AND MITIGATING FLOOR MATS (U.S. CLS. 21, 23, 26, 36 AND 38).
ERIN FALK, EXAMINING ATTORNEY

SN 85-442,778. HEXAGRID COMPUTING, INC., CHESTERFIELD, MO. FILED 10-8-2011.

OUR SOFTWARE, YOUR CLOUD

THE MARK CONSISTS OF STANDARD CHARACTERS WITHOUT CLAIM TO ANY PARTICULAR FONT, STYLE, SIZE, OR COLOR.

FOR COMPUTER SOFTWARE FOR MANAGEMENT OF INFORMATION TECHNOLOGY (IT) INFRASTRUCTURE AS CLOUD COMPUTING (U.S. CLS. 21, 23, 26, 36 AND 38).

FIRST USE 9-0-2011; IN COMMERCE 9-0-2011.
H. M. FISHER, EXAMINING ATTORNEY

SN 85-443,243. THE A.I. GROUP, INC., ALPHARETTA, GA. FILED 10-10-2011.

BeneTouch

THE MARK CONSISTS OF STANDARD CHARACTERS WITHOUT CLAIM TO ANY PARTICULAR FONT, STYLE, SIZE, OR COLOR.

FOR DOWNLOADABLE COMPUTER SOFTWARE IN THE NATURE OF A MOBILE APPLICATION FOR USE IN ACCESSING EMPLOYEE BENEFITS INFORMATION (U.S. CLS. 21, 23, 26, 36 AND 38).

FIRST USE 8-1-2011; IN COMMERCE 9-7-2011.
ROBIN CHOSID, EXAMINING ATTORNEY

CLASS 9—(Continued).

SN 85-443,345. MANLEY LABORATORIES INCORPORATED, CHINO, CA. FILED 10-10-2011.



OWNER OF U.S. REG. NO. 2,573,817.

NO CLAIM IS MADE TO THE EXCLUSIVE RIGHT TO USE "IRON", APART FROM THE MARK AS SHOWN.

THE MARK CONSISTS OF A DIVIDED RECTANGLE WITH THE STYLIZED WORD "MANLEY" IN THE TOP HALF OF THE RECTANGLE AND THE STYLIZED WORD "IRON" IN THE BOTTOM, SHADED HALF.

FOR CHOKING COILS FOR USE IN ELECTRICAL APPARATUS; TRANSFORMERS (U.S. CLS. 21, 23, 26, 36 AND 38).

CHRISTOPHER BUONGIORNO, EXAMINING ATTORNEY

SN 85-443,448. ITRACS CORPORATION, OAK BROOK, IL. FILED 10-10-2011.

iTRACS Physical Layer Manager

THE MARK CONSISTS OF STANDARD CHARACTERS WITHOUT CLAIM TO ANY PARTICULAR FONT, STYLE, SIZE, OR COLOR.

OWNER OF U.S. REG. NO. 2,521,105.

NO CLAIM IS MADE TO THE EXCLUSIVE RIGHT TO USE "PHYSICAL LAYER MANAGER", APART FROM THE MARK AS SHOWN.

FOR COMPUTER SOFTWARE FOR MANAGING THE INFRASTRUCTURE OF A DATA CENTER (U.S. CLS. 21, 23, 26, 36 AND 38).

KHANH LE, EXAMINING ATTORNEY

SN 85-443,465. ITRACS CORPORATION, OAK BROOK, IL. FILED 10-10-2011.

iTRACS Infrastructure Manager

THE MARK CONSISTS OF STANDARD CHARACTERS WITHOUT CLAIM TO ANY PARTICULAR FONT, STYLE, SIZE, OR COLOR.

OWNER OF U.S. REG. NO. 2,521,105.

NO CLAIM IS MADE TO THE EXCLUSIVE RIGHT TO USE "INFRASTRUCTURE MANAGER", APART FROM THE MARK AS SHOWN.

FOR COMPUTER SOFTWARE FOR MANAGING THE INFRASTRUCTURE OF A DATA CENTER (U.S. CLS. 21, 23, 26, 36 AND 38).

KHANH LE, EXAMINING ATTORNEY

CLASS 9—(Continued).

SN 85-443,560. 745 LLC, BOSTON, MA. FILED 10-10-2011.

ISOULO

THE MARK CONSISTS OF STANDARD CHARACTERS WITHOUT CLAIM TO ANY PARTICULAR FONT, STYLE, SIZE, OR COLOR.

FOR COMPUTER SOFTWARE APPLICATIONS IN THE FIELD OF MUSICAL VIDEO AND AUDIO RECORDING, FOR USE IN CONNECTION WITH MOBILE WIRELESS DEVICES, CELLULAR AND MOBILE PHONES, AND OTHER HANDHELD ELECTRONIC DEVICES; COMPUTER SOFTWARE APPLICATIONS FOR THE DOWNLOADING AND REPLAYING OF KARAOKE MUSIC TRACKS ON WIRELESS DEVICES, CELLULAR AND MOBILE PHONE, AND OTHER HANDHELD ELECTRONIC DEVICES; COMPUTER SOFTWARE APPLICATIONS FOR THE RECORDING AND PLAYBACK OF AUDIO TRACKS AND VIDEO FILES ON WIRELESS DEVICES, CELLULAR AND MOBILE PHONE, AND OTHER HANDHELD ELECTRONIC DEVICES; COMPUTER SOFTWARE APPLICATIONS FOR THE ONLINE STREAMING OF AUDIO TRACKS AND VIDEO FILES BY MEANS OF WIRELESS DEVICES, CELLULAR AND MOBILE PHONES AND OTHER HANDHELD ELECTRONIC DEVICES; COMPUTER SOFTWARE APPLICATIONS FOR POSTING OF AUDIO TRACKS AND VIDEO FILES ON SOCIAL NETWORKING WEB SITES BY MEANS OF MOBILE WIRELESS DEVICES, CELLULAR AND MOBILE PHONES AND OTHER HANDHELD ELECTRONIC DEVICES; MICROPHONES; MICROPHONES FOR USE WITH HAND-HELD ELECTRONIC DEVICES (U.S. CLS. 21, 23, 26, 36 AND 38).

HOWARD B. LEVINE, EXAMINING ATTORNEY

SN 85-443,980. HANDELABRA STUDIO LLC, UNIVERSITY HEIGHTS, OH. FILED 10-11-2011.



THE MARK CONSISTS OF A CIRCLE WITH A BOXING GLOVE IN THE CENTER, SURROUNDED BY 2 STARS ON EITHER SIDE, THE WORD "UNCLE" ON TOP AND THE WORD "SLAM" ON THE BOTTOM, COMPRISING A SEAL.

FOR DOWNLOADABLE SOFTWARE IN THE NATURE OF A MOBILE APPLICATION FOR ENTERTAINMENT PURPOSES, NAMELY, FIGHTING VIDEO GAME SOFTWARE WHERE PLAYERS ENGAGE IN SIMULATED BOXING AND FIGHTING; VIDEO GAME SOFTWARE (U.S. CLS. 21, 23, 26, 36 AND 38).

FIRST USE 12-16-2011; IN COMMERCE 12-16-2011.
MICHAEL GAFFAR, EXAMINING ATTORNEY

CLASS 9—(Continued).

SN 85-443,981. HANDELABRA STUDIO LLC, UNIVERSITY HEIGHTS, OH. FILED 10-11-2011.



NO CLAIM IS MADE TO THE EXCLUSIVE RIGHT TO USE "PRESIDENT VS. PRESIDENT", APART FROM THE MARK AS SHOWN.

THE MARK CONSISTS OF A SEAL COMPRISING THREE CONCENTRIC CIRCLES, WITH AN INNER CIRCLE WITH A STYLIZED DEPICTION OF AN EAGLE WEARING A SHIELD AND HOLDING A PAIR OF BOXING GLOVES IN ITS BEAK, WITH THE STYLIZED WORDING "UNCLE SLAM" AND "PRESIDENT VS. PRESIDENT" WRITTEN IN THE BORDER OF THE SECOND OUTER-MOST CIRCLE, WITH A FIVE-POINTED STAR SET BOTH BEFORE AND AFTER THE WORDING "UNCLE SLAM" IN THE BORDER OF THE SECOND OUTER-MOST CIRCLE.

FOR DOWNLOADABLE SOFTWARE IN THE NATURE OF A MOBILE APPLICATION FOR ENTERTAINMENT PURPOSES, NAMELY, FIGHTING VIDEO GAME SOFTWARE WHERE PLAYERS ENGAGE IN SIMULATED BOXING AND FIGHTING; VIDEO GAME SOFTWARE (U.S. CLS. 21, 23, 26, 36 AND 38).

FIRST USE 12-16-2011; IN COMMERCE 12-16-2011.
MICHAEL GAFFAR, EXAMINING ATTORNEY

SN 85-444,139. COMPREHENSIVE BASKETBALL, LLC, RICHMOND, VA. FILED 10-11-2011.



NO CLAIM IS MADE TO THE EXCLUSIVE RIGHT TO USE "COMPREHENSIVE BASKETBALL", APART FROM THE MARK AS SHOWN.

THE MARK CONSISTS OF THE WORDS "COMPREHENSIVE BASKETBALL". THE WORD "COMPREHENSIVE" IS PRESENTED IN A STYLIZED FONT ABOVE THE WORD "BASKETBALL". THE LETTER "O" IN THE WORD "COMPREHENSIVE" IS PRESENTED IN THE IMAGE OF A BASKETBALL. THE WORD "BASKETBALL" IS ENCLOSED IN RECTANGULAR SHAPE. THE RECTANGLE IS NOT CLOSED AT THE BEGINNING AND ENDING OF THE WORD "COMPREHENSIVE".

FOR DVDS FEATURING INSTRUCTION IN THE SPORT OF BASKETBALL; VISUAL AND AUDIO RECORDINGS FEATURING INSTRUCTION IN THE SPORT OF BASKETBALL (U.S. CLS. 21, 23, 26, 36 AND 38).

FIRST USE 9-0-2011; IN COMMERCE 9-0-2011.
JAY FLOWERS, EXAMINING ATTORNEY

CLASS 9—(Continued).

SN 85-444,550. CARVIN POOL EQUIPMENT INC., HYACINTHE, QUEBEC, CANADA, FILED 10-11-2011.

MASTERMIND

THE MARK CONSISTS OF STANDARD CHARACTERS WITHOUT CLAIM TO ANY PARTICULAR FONT, STYLE, SIZE, OR COLOR.

FOR REMOTE CONTROLS FOR REGULATING WATER FLOW AND WATER TEMPERATURE IN POOL INSTALLATIONS (U.S. CLS. 21, 23, 26, 36 AND 38).

FIRST USE 9-11-1998; IN COMMERCE 9-11-1998.
ELLEN BURNS, EXAMINING ATTORNEY

CLASS 9—(Continued).

SN 85-444,676. HELMET HUGGERS, LLC, RIDGEWOOD, NJ, FILED 10-11-2011.



NO CLAIM IS MADE TO THE EXCLUSIVE RIGHT TO USE "HELMET", APART FROM THE MARK AS SHOWN.

THE MARK CONSISTS OF THE TERM "HELMET HUGGERS" WITH THE DESIGN OF A STYLIZED STICK FIGURE WEARING SKIS AND A HELMET. THE TWO "H"'S COMPRISE THE BODY OF THE STICK FIGURE.

FOR DECORATIVE REMOVABLE COVERS FOR RIGID SPORTS HELMETS, NAMELY, SKI HELMETS, SNOWBOARD HELMETS, SKATEBOARD HELMETS AND BICYCLE HELMETS (U.S. CLS. 21, 23, 26, 36 AND 38).

GIANCARLO CASTRO, EXAMINING ATTORNEY

SN 85-444,654. HPI, LLC, HOUSTON, TX. FILED 10-11-2011.



SN 85-444,753. EPCSOLUTIONS, INC., GREAT FALLS, VA, FILED 10-11-2011.

NUTRIFACTS

NO CLAIM IS MADE TO THE EXCLUSIVE RIGHT TO USE "LLC", APART FROM THE MARK AS SHOWN.

THE MARK CONSISTS OF THE STYLIZED IMAGE OF A TURBINE, WITH THE WORDING "HPI, LLC".

FOR AUTOMATED PROCESS CONTROL SYSTEM, NAMELY, MICRO-PROCESSOR BASED HARDWARE AND SOFTWARE USED TO MONITOR THE STATUS OF INDUSTRIAL MACHINERY, NAMELY, TURBINES, GENERATORS AND COMPRESSORS; TURBINE CONTROL SYSTEMS COMPRISING ELECTRONIC SENSORS AND RELATED SOFTWARE (U.S. CLS. 21, 23, 26, 36 AND 38).

FIRST USE 0-0-2002; IN COMMERCE 0-0-2002.
GIANCARLO CASTRO, EXAMINING ATTORNEY

THE MARK CONSISTS OF STANDARD CHARACTERS WITHOUT CLAIM TO ANY PARTICULAR FONT, STYLE, SIZE, OR COLOR.

FOR COMPUTER SOFTWARE FOR USE IN ASSESSING AND MANAGING NUTRITIONAL INFORMATION BASED ON A USER'S NUTRITIONAL NEEDS (U.S. CLS. 21, 23, 26, 36 AND 38).

RENEE MCCRAY, EXAMINING ATTORNEY

CLASS 9—(Continued).

SN 85-444,991. HIT THE SPOT, LLC, SEATTLE, WA. FILED 10-12-2011.



THE COLOR(S) ORANGE AND BLACK IS/ARE CLAIMED AS A FEATURE OF THE MARK.

THE MARK CONSISTS OF THE TEXT "HIT THE SPOT" AND THE TAG LINE "FOOD THAT FINDS YOU" IN BLACK, BOLD FONT. TO THE LEFT OF THE TEXT IS AN ORANGE FORK ENCIRCLED BY TWO BLACK CIRCLES, ONE INSIDE THE OTHER. BOTH CIRCLES ARE BROKEN AT 6 O'CLOCK BY THE HANDLE OF THE FORK. THE INNER CIRCLE DOES NOT BREAK AT ANY OTHER PLACE. THE OUTER CIRCLE HAS SMALL BREAKS AT 12, 3, AND 9 O'CLOCK.

FOR COMPUTER APPLICATION SOFTWARE FOR WEB BROWSERS AND MOBILE PHONES, NAMELY, SOFTWARE FOR LOCATING RESTAURANTS, ORDERING AND DELIVERING FOOD UTILIZING GLOBAL POSITIONING SYSTEM (GPS) TECHNOLOGY (U.S. CLS. 21, 23, 26, 36 AND 38).

FIRST USE 10-1-2011; IN COMMERCE 10-1-2011.
BILL DAWE, EXAMINING ATTORNEY

CLASS 9—(Continued).

SN 85-445,370. STALEY, TREVOR, AGOURA HILLS, CA. FILED 10-12-2011.



THE MARK CONSISTS OF THE STYLIZED TEXT "STYLWIRE".

FOR EARPHONES AND HEADPHONES (U.S. CLS. 21, 23, 26, 36 AND 38).
SALLY SHIH, EXAMINING ATTORNEY

SN 85-445,021. PERFECTLY INCORPORATION, PICO RIVERA, CA. FILED 10-12-2011.

PERFECTLY INCORPORATION

THE MARK CONSISTS OF STANDARD CHARACTERS WITHOUT CLAIM TO ANY PARTICULAR FONT, STYLE, SIZE, OR COLOR.

FOR USB (UNIVERSAL SERIAL BUS) HARDWARE, BLANK USB FLASH DRIVES (U.S. CLS. 21, 23, 26, 36 AND 38).

ROBERT STRUCK, EXAMINING ATTORNEY

SN 85-445,390. QUALCOMM ISKOOT, INC., SAN DIEGO, CA. FILED 10-12-2011.

SOCIAL SOURCE

THE MARK CONSISTS OF STANDARD CHARACTERS WITHOUT CLAIM TO ANY PARTICULAR FONT, STYLE, SIZE, OR COLOR.

NO CLAIM IS MADE TO THE EXCLUSIVE RIGHT TO USE "SOCIAL", APART FROM THE MARK AS SHOWN.

FOR COMPUTER SOFTWARE AND DOWNLOADABLE MOBILE APPLICATION SOFTWARE FOR CONSOLIDATING SOCIAL MEDIA APPLICATIONS INTO ONE USER INTERFACE (U.S. CLS. 21, 23, 26, 36 AND 38).

KAREN K. BUSH, EXAMINING ATTORNEY

SN 85-445,293. MQBIX ACOUSTICS CORPORATION, PLAINVIEW, NY. FILED 10-12-2011.

MQbix

THE MARK CONSISTS OF STANDARD CHARACTERS WITHOUT CLAIM TO ANY PARTICULAR FONT, STYLE, SIZE, OR COLOR.

FOR AUDIO CABLES; AUDIO SPEAKERS; EARPHONES; HEADPHONES; LOUD SPEAKERS (U.S. CLS. 21, 23, 26, 36 AND 38).

MARILYN IZZI, EXAMINING ATTORNEY

SN 85-445,391. BAFFLE BY TRAVEL INC., TORONTO, ONTARIO, CANADA, FILED 10-12-2011.

TRIPILATOR

THE MARK CONSISTS OF STANDARD CHARACTERS WITHOUT CLAIM TO ANY PARTICULAR FONT, STYLE, SIZE, OR COLOR.

FOR COMPUTER APPLICATION SOFTWARE FOR MOBILE PHONES, NAMELY, SOFTWARE FOR ACCESSING A MODERATED LISTING OF PLACES AND THINGS TO DO IN VARIOUS CITIES AROUND THE WORLD; DOWNLOADABLE SOFTWARE IN THE NATURE OF A MOBILE APPLICATION FOR ACCESSING A MODERATED LISTING OF PLACES AND THINGS TO DO IN VARIOUS CITIES AROUND THE WORLD (U.S. CLS. 21, 23, 26, 36 AND 38).

KAREN K. BUSH, EXAMINING ATTORNEY

CLASS 9—(Continued).

SN 85-445,583. YES GROUP, INC., NEW YORK, NY. FILED 10-12-2011.



THE MARK CONSISTS OF THE LETTERS "C" AND "G" SHOWN CONSECUTIVELY AND INTERSECTED BY A ZERO, ALL SHOWN ABOVE THE WORDS "COGNI WEAR" SEPARATED BY A DASH SYMBOL.

FOR SPECTACLES, EYEGASSES, SPORTS GOGGLES, SKI GOGGLES, SUNGLASSES, OPTICAL FRAMES, MOTORCYCLE GOGGLES (U.S. CLS. 21, 23, 26, 36 AND 38).
MICHAEL WEBSTER, EXAMINING ATTORNEY

SN 85-445,697. PRECISION ONE LIFECARE LIMITED, SHEUNG WAN, HONG KONG, FILED 10-12-2011.

ired

THE MARK CONSISTS OF STANDARD CHARACTERS WITHOUT CLAIM TO ANY PARTICULAR FONT, STYLE, SIZE, OR COLOR.

FOR BODY SCALES; KITCHEN SCALES; BODY SCALES AND KITCHEN SCALES WITH INFRA RED TRANSMISSION FOR TRANSMITTING DATA OF MEASURED VALUE TO THE REMOTE DISPLAY (U.S. CLS. 21, 23, 26, 36 AND 38).

RONALD MCMORROW, EXAMINING ATTORNEY

SN 85-445,800. VERNIER SOFTWARE & TECHNOLOGY, LLC, BEAVERTON, OR. FILED 10-12-2011.

LABQUEST CONNECT

THE MARK CONSISTS OF STANDARD CHARACTERS WITHOUT CLAIM TO ANY PARTICULAR FONT, STYLE, SIZE, OR COLOR.

FOR COMPUTER SOFTWARE FOR CONTROLLING DATA COLLECTION AND FOR DATA ANALYSIS FOR USE IN ELEMENTARY SCHOOL, JUNIOR HIGH SCHOOL, HIGH SCHOOL, AND COLLEGE SCIENCE AND MATH LABORATORIES AND CLASSROOMS, NAMELY FOR MEASURING, ANALYZING, GRAPHING, RECORDING, AND REPORTING PHYSICAL QUANTITIES, DISTANCE, VELOCITY, TEMPERATURE, PRESSURE, DISSOLVED OXYGEN, CONDUCTIVITY, ACCELERATION DATA AND OTHER PHYSICAL AND SCIENTIFIC MEASUREMENTS (U.S. CLS. 21, 23, 26, 36 AND 38).

LEIGH LOWRY, EXAMINING ATTORNEY

CLASS 9—(Continued).

SN 85-445,893. SCIENTIFIC PLASTIC PRODUCTS, INC., OCEANSIDE, CA. FILED 10-12-2011.



THE MARK CONSISTS OF THE WORDS "OPTIMUM-GROWTH" WITH A FLASK INSIDE THE FIRST LETTER "O". THE FIRST LETTER "O" HAS AN OVAL SHAPE, AND THE DOT OVER THE LETTER "I" IS THE SAME OVAL SHAPE BUT SMALLER.

FOR PLASTIC CONTAINERS FOR BIOLOGICAL MATERIALS FOR RESEARCH AND LABORATORY USE AND FOR COMMERCIAL PRODUCTION OF CELL CULTURES (U.S. CLS. 21, 23, 26, 36 AND 38).

FIRST USE 3-24-2011; IN COMMERCE 3-24-2011.

ANDREW RHIM, EXAMINING ATTORNEY

SN 85-445,966. AVEPOINT, INC., JERSEY CITY, NJ. FILED 10-12-2011.

Warfighter Kit

THE MARK CONSISTS OF STANDARD CHARACTERS WITHOUT CLAIM TO ANY PARTICULAR FONT, STYLE, SIZE, OR COLOR.

NO CLAIM IS MADE TO THE EXCLUSIVE RIGHT TO USE "KIT", APART FROM THE MARK AS SHOWN.

FOR COMPUTER SOFTWARE FOR DATA BACK UP, PROTECTION, ARCHIVING, DISASTER RECOVERY, MIGRATION AND CONTENT MANAGEMENT (U.S. CLS. 21, 23, 26, 36 AND 38).

BARBARA BROWN, EXAMINING ATTORNEY

SN 85-446,123. ROBERT MALCOLM JOHNSON, NEEDHAM, MA. FILED 10-12-2011.

nail in the road

THE MARK CONSISTS OF STANDARD CHARACTERS WITHOUT CLAIM TO ANY PARTICULAR FONT, STYLE, SIZE, OR COLOR.

FOR AUDIO AND VIDEO RECORDINGS FEATURING MUSIC AND ARTISTIC PERFORMANCES; COMPACT DISCS FEATURING MUSIC; DIGITAL MUSIC DOWNLOADABLE FROM THE INTERNET (U.S. CLS. 21, 23, 26, 36 AND 38).

FIRST USE 9-16-2011; IN COMMERCE 9-16-2011.

CHRISIE B. KING, EXAMINING ATTORNEY

CLASS 9—(Continued).

SN 85-446,239. FORTUNA MAJOR STUDIOS LLC, CUMMING, GA. FILED 10-13-2011.



NO CLAIM IS MADE TO THE EXCLUSIVE RIGHT TO USE "STUDIOS", APART FROM THE MARK AS SHOWN.

THE MARK CONSISTS OF A COIN FEATURING SIX DIAMONDS INSET INTO A CHALICE HOLDING A SUN THAT IS EMITTING CURVED RAYS. THE STYLIZED TEXT "FORTUNA MAJOR" IS UNDER THE CHALICE AND UNDER THAT TEXT IS THE STYLIZED TEXT "STUDIOS" IN TR AVALON FONT.

FOR COMPUTER GAME SOFTWARE FOR PERSONAL COMPUTERS, HOME VIDEO GAME CONSOLES, AND HANDHELD DEVICES (U.S. CLS. 21, 23, 26, 36 AND 38).
JAMES A. RAUEN, EXAMINING ATTORNEY

SN 85-446,395. AEROSONIC CORPORATION, CLEARWATER, FL. FILED 10-13-2011.



THE MARK CONSISTS OF TWO CONCENTRIC ARCS ROTATED NINETY DEGREES CLOCKWISE WITHIN A SOLID FILL SQUARE.

FOR AIRCRAFT INSTRUMENTS AND PARTS THEREFORE—NAMESLY, ALTIMETERS, AIRSPEED INDICATORS, RATE OF CLIMB INDICATORS, VERTICAL VELOCITY INDICATORS, CABIN PRESSURE INDICATORS, COMPASSES, CABIN ALTITUDE AND DIFFERENTIAL PRESSURE INDICATORS, VACUUM GAUGES, TEMPERATURE GAUGES, OIL TEMPERATURE GAUGES, OIL PRESSURE INDICATORS, TURN AND BANK INDICATORS, AIRSPEED AND MACH INDICATORS, MAXIMUM ALLOWABLE AIRSPEED INDICATORS, SERVO PNEUMATIC ALTIMETERS, ALTITUDE WARNING SYSTEMS, NAMESLY, ALTIMETERS, ENCODING ALTIMETERS, BLIND ENCODERS AND TRANSPONDERS (U.S. CLS. 21, 23, 26, 36 AND 38).

FIRST USE 8-19-2003; IN COMMERCE 8-21-2006.
GIANCARLO CASTRO, EXAMINING ATTORNEY

CLASS 9—(Continued).

SN 85-446,441. BIOTECHNOLOGY INSTITUTE, S.L., 01005 VITORIA, SPAIN, FILED 10-13-2011.

PLASMATERM H

THE MARK CONSISTS OF STANDARD CHARACTERS WITHOUT CLAIM TO ANY PARTICULAR FONT, STYLE, SIZE, OR COLOR.

THE WORDING "PLASMATERM" HAS NO MEANING IN A FOREIGN LANGUAGE.

FOR OVENS FOR LABORATORY USE (U.S. CLS. 21, 23, 26, 36 AND 38).

FIRST USE 6-2-2010; IN COMMERCE 7-12-2010.

ELISSA GARBER KON, EXAMINING ATTORNEY

SN 85-446,458. B AND H SYSTEMS LLC, NEW YORK, NY. FILED 10-13-2011.

Fit Locker

THE MARK CONSISTS OF STANDARD CHARACTERS WITHOUT CLAIM TO ANY PARTICULAR FONT, STYLE, SIZE, OR COLOR.

FOR VENDING MACHINES (U.S. CLS. 21, 23, 26, 36 AND 38).

FRANK LATTUCA, EXAMINING ATTORNEY

SN 85-446,515. TOUCHSTREAM TECHNOLOGIES, INC., VALHALLA, NY. FILED 10-13-2011.



THE COLOR(S) BLACK, BLUE AND WHITE IS/ARE CLAIMED AS A FEATURE OF THE MARK.

THE MARK CONSISTS OF THE WORDING "SHODOGG" IN BLUE NEXT TO THE STYLIZED IMAGE OF A DOG'S HEAD IN BLACK AND WHITE.

FOR SOFTWARE TO ENABLE ONLINE CONTENT TO BE VIEWED ON ANY CONNECTED SCREEN (U.S. CLS. 21, 23, 26, 36 AND 38).

KRISTIN DAHLING, EXAMINING ATTORNEY

CLASS 9—(Continued).

SN 85-446,554. FERRY INDUSTRIES, INC., STOW, OH. FILED 10-13-2011.

ROTOCURE 2000

THE MARK CONSISTS OF STANDARD CHARACTERS WITHOUT CLAIM TO ANY PARTICULAR FONT, STYLE, SIZE, OR COLOR.

FOR COMPUTER SOFTWARE AND FIRMWARE FOR OPERATING A CONTROL SYSTEM FOR ROTATIONAL MOLDING MACHINES (U.S. CLS. 21, 23, 26, 36 AND 38). FIRST USE 1-1-1988; IN COMMERCE 1-1-1988. JEFFREY LOOK, EXAMINING ATTORNEY

SN 85-446,579. FISSION LLC, NEW YORK, NY. FILED 10-13-2011.

NOOK SIMPLE TOUCH

THE MARK CONSISTS OF STANDARD CHARACTERS WITHOUT CLAIM TO ANY PARTICULAR FONT, STYLE, SIZE, OR COLOR.

OWNER OF U.S. REG. NOS. 4,013,524 AND 4,023,198. NO CLAIM IS MADE TO THE EXCLUSIVE RIGHT TO USE "TOUCH", APART FROM THE MARK AS SHOWN. FOR PORTABLE ELECTRONIC APPARATUS FOR READING, DISPLAYING, RECEIVING, PURCHASING, SHARING, LENDING, ACCESSING AND STORING DOWNLOADABLE ELECTRONIC PUBLICATIONS, NAMELY, BOOKS, E-BOOKS, MAGAZINES, NEWSPAPERS, TEXT, IMAGES, DIGITAL WEB SITE CONTENT AND DIGITAL MEDIA FEATURING MUSIC THROUGH WIRED AND WIRELESS INTERNET ACCESS, ACCESSORIES THEREFOR AND INSTRUCTIONAL MANUALS, SOLD AS A UNIT; COMPUTER SOFTWARE FOR DISPLAYING, RECEIVING, READING, PURCHASING AND ACCESSING DOWNLOADABLE ELECTRONIC PUBLICATIONS, SYNCING ELECTRONIC PUBLICATIONS WITH PORTABLE ELECTRONIC APPARATUS, LOANING AND SHARING ELECTRONIC PUBLICATIONS WITH THIRD PARTIES AND SAMPLING ELECTRONIC PUBLICATIONS; DOWNLOADABLE COMPUTER SOFTWARE FOR DISPLAYING, RECEIVING AND READING DOWNLOADABLE ELECTRONIC PUBLICATIONS AND SYNCING ELECTRONIC PUBLICATIONS WITH PORTABLE ELECTRONIC APPARATUS, LOANING AND SHARING ELECTRONIC PUBLICATIONS WITH THIRD PARTIES AND SAMPLING ELECTRONIC PUBLICATIONS; COMPUTER SOFTWARE FOR USE IN READING, DISPLAYING, PURCHASING, SHARING, LENDING AND ACCESSING ELECTRONIC PUBLICATIONS AND DIGITAL MEDIA FEATURING BOOKS, NEWSPAPERS, MAGAZINES, PERIODICALS, DIGITAL IMAGES, WEB SITES, MUSIC, GAMES AND OTHER

CLASS 9—(Continued).

DIGITAL ENTERTAINMENT, AND INSTRUCTIONAL MANUALS, SOLD AS A UNIT; DOWNLOADABLE COMPUTER SOFTWARE FOR USE IN READING, DISPLAYING, PURCHASING, SHARING, LENDING AND ACCESSING ELECTRONIC PUBLICATIONS AND DIGITAL MEDIA FEATURING BOOKS, NEWSPAPERS, MAGAZINES, DIGITAL IMAGES, WEB SITES, MUSIC, GAMES AND OTHER DIGITAL ENTERTAINMENT, AND INSTRUCTIONAL MANUALS, SOLD AS A UNIT; DOWNLOADABLE ELECTRONIC PUBLICATIONS IN THE NATURE OF FICTION AND NON-FICTION BOOKS, MAGAZINES, NEWSPAPERS, JOURNALS, PERIODICALS, MANUALS AND GUIDEBOOKS ON A VARIETY OF TOPICS; AUDIO BOOKS IN THE NATURE OF FICTION AND NON-FICTION WORKS ON A VARIETY OF TOPICS, DOWNLOADABLE MP3 FILES, MP3 RECORDINGS, ON-LINE DISCUSSION BOARDS, WEBCASTS, WEBINARS AND PODCASTS FEATURING MUSIC, AUDIO BOOKS ON A VARIETY OF TOPICS AND NEWS BROADCASTS (U.S. CLS. 21, 23, 26, 36 AND 38).

EMILY CARLSEN, EXAMINING ATTORNEY

SN 85-446,620. RALSTON, DOUG, SCOTTSDALE, AZ. FILED 10-13-2011.

mobiTravel

THE MARK CONSISTS OF STANDARD CHARACTERS WITHOUT CLAIM TO ANY PARTICULAR FONT, STYLE, SIZE, OR COLOR.

FOR COMPUTER APPLICATION SOFTWARE FOR MOBILE PHONES, TABLETS, NAMELY, SOFTWARE FOR TRAVEL AND TOURISM THAT ENABLES CONSUMERS TO DETECT THEIR LOCATION AND RECEIVE LOCATION INFORMATION FOR BUSINESSES AND SERVICES IN THAT AREA, MAKE TRAVEL, RENTAL CAR AND LODGING RESERVATIONS VIA GLOBAL COMPUTER NETWORK, PURCHASE AIRLINE, BOAT, TRAIN OR OTHER TRANSPORTATION TICKETS AND PERFORM ELECTRONIC COMMERCE BUSINESS TRANSACTIONS SUCH AS PAYING FOR TRANSPORTATION TICKETS, LODGING, CAR RENTALS OR ENTERTAINMENT TICKETS (U.S. CLS. 21, 23, 26, 36 AND 38).

AMY C. KEAN, EXAMINING ATTORNEY

SN 85-446,628. GLOBE FOOD EQUIPMENT COMPANY, DAYTON, OH. FILED 10-13-2011.



OWNER OF U.S. REG. NOS. 2,504,703 AND 2,789,358. THE MARK CONSISTS OF THE WORD "GLOBE" IN A STYLIZED FONT WITHIN AN OVAL. FOR SCALES, WEIGHING SCALES, CALCULATING SCALES, SCALES FOR PORTION CONTROL AND COMPUTING PRICES (U.S. CLS. 21, 23, 26, 36 AND 38). FIRST USE 2-28-2011; IN COMMERCE 2-28-2011. AMY C. KEAN, EXAMINING ATTORNEY

CLASS 9—(Continued).

SN 85-446,651. RALSTON, DOUG, SCOTTSDALE, AZ. FILED 10-13-2011.

mobiRewards

THE MARK CONSISTS OF STANDARD CHARACTERS WITHOUT CLAIM TO ANY PARTICULAR FONT, STYLE, SIZE, OR COLOR.

FOR COMPUTER SOFTWARE, NAMELY, SOFTWARE DEVELOPMENT TOOLS FOR THE CREATION OF MOBILE INTERNET APPLICATIONS AND CLIENT INTERFACES (U.S. CLS. 21, 23, 26, 36 AND 38).

AMY C. KEAN, EXAMINING ATTORNEY

CLASS 9—(Continued).

SN 85-446,828. OXFORD RED VENTURES, BALTIMORE, MD. FILED 10-13-2011.

cushpad

THE MARK CONSISTS OF THE STYLIZED TEXT "CUSH-PAD".

FOR TABLET COMPUTER CARRYING CASES (U.S. CLS. 21, 23, 26, 36 AND 38).

GENE MACIOL, EXAMINING ATTORNEY

SN 85-446,719. WURSTEN PROPERTIES LLC, NORTH LOGAN, UT. FILED 10-13-2011.

i-troll

THE MARK CONSISTS OF STANDARD CHARACTERS WITHOUT CLAIM TO ANY PARTICULAR FONT, STYLE, SIZE, OR COLOR.

FOR SATELLITE NAVIGATIONAL SYSTEM, NAMELY, A GLOBAL POSITIONING SYSTEM (GPS) FOR USE WITH TROLLING MOTORS FOR SPORT FISHING (U.S. CLS. 21, 23, 26, 36 AND 38).

JAY FLOWERS, EXAMINING ATTORNEY

SN 85-446,855. INTERPHASE CORPORATION, PLANO, TX. FILED 10-13-2011.

Penveu

THE MARK CONSISTS OF THE STYLIZED WORD PENVEU.

FOR COMPUTER CURSOR CONTROL DEVICES, NAMELY, COMPUTER MOUSE; COMPUTER WHITEBOARDS; REMOTE CONTROLS FOR COMPUTERS, TELEVISIONS, DISPLAYS, PROJECTORS; VIDEO GAME INTERACTIVE HAND HELD REMOTE CONTROLS FOR PLAYING ELECTRONIC GAMES; VIDEO GAME INTERACTIVE REMOTE CONTROL UNITS; WIRELESS PRESENTER IN THE NATURE OF A WIRELESS REMOTE POINTER (U.S. CLS. 21, 23, 26, 36 AND 38).

CHRISTOPHER SIDOTI, EXAMINING ATTORNEY

SN 85-446,770. FRY, INC., ANN ARBOR, MI. FILED 10-13-2011.

Mistore

THE MARK CONSISTS OF STANDARD CHARACTERS WITHOUT CLAIM TO ANY PARTICULAR FONT, STYLE, SIZE, OR COLOR.

FOR COMPUTER SOFTWARE FOR USE IN CONNECTION WITH RETAIL POINT OF SALE AND INVENTORY MANAGEMENT (U.S. CLS. 21, 23, 26, 36 AND 38).

SALLY SHIH, EXAMINING ATTORNEY

SN 85-446,941. CTS CORPORATION, ELKHART, IN. FILED 10-13-2011.

CLEARPLEX

THE MARK CONSISTS OF STANDARD CHARACTERS WITHOUT CLAIM TO ANY PARTICULAR FONT, STYLE, SIZE, OR COLOR.

FOR FREQUENCY SIGNAL FILTERS AND FREQUENCY SIGNAL FILTER MODULES, NAMELY, CERAMIC WAVEGUIDE FREQUENCY SIGNAL FILTERS AND FILTER MODULES FOR USE IN ELECTRONIC EQUIPMENT FOR FILTERING FREQUENCY SIGNALS (U.S. CLS. 21, 23, 26, 36 AND 38).

MARK SPARACINO, EXAMINING ATTORNEY

CLASS 9—(Continued).

SN 85-446,964. STORM, JONATHAN RANDALL HOUGHT-
ALING, NORFOLK, VA. FILED 10-13-2011.

EARTHTUNES

THE MARK CONSISTS OF STANDARD CHARACTERS
WITHOUT CLAIM TO ANY PARTICULAR FONT, STYLE,
SIZE, OR COLOR.

OWNER OF U.S. REG. NO. 2,490,155.

FOR AUDIO CASSETTES FEATURING MUSIC; COM-
PACT DISCS FEATURING MUSIC; PHONOGRAPH RE-
CORDS FEATURING MUSIC (U.S. CLS. 21, 23, 26, 36
AND 38).

FIRST USE 9-0-1983; IN COMMERCE 9-0-1983.

AMY HELLA, EXAMINING ATTORNEY

SN 85-446,998. ILLINOIS TOOL WORKS, INC., GLENVIEW,
IL. FILED 10-13-2011.



THE MARK CONSISTS OF THE LETTERS "IRD" IN
UPPERCASE STYLIZED FONT SUPERIMPOSED OVER A
QUADRANGLE BLOCK.

FOR SCIENTIFIC, OPTICAL, AND MEASURING AP-
PARATUS AND INSTRUMENTS, NAMELY, SEMICON-
DUCTOR RADIATION SENSORS (U.S. CLS. 21, 23, 26, 36
AND 38).

FIRST USE 10-4-2011; IN COMMERCE 10-4-2011.

MEGHAN REINHART, EXAMINING ATTORNEY

SN 85-447,005. JAMES STANFIELD COMPANY, INC., SAN-
TA BARBARA, CA. FILED 10-13-2011.

FIRST IMPRESSIONS

THE MARK CONSISTS OF STANDARD CHARACTERS
WITHOUT CLAIM TO ANY PARTICULAR FONT, STYLE,
SIZE, OR COLOR.

OWNER OF U.S. REG. NO. 2,027,399.

FOR A SERIES OF VIDEO AND/OR AUDIO RECORD-
INGS THAT TEACH APPROPRIATE BEHAVIOR AND
APPEARANCE IN EVERYDAY WORK AND PERSONAL
LIFE TO CHILDREN AND ADULTS (U.S. CLS. 21, 23, 26,
36 AND 38).

FIRST USE 6-6-1996; IN COMMERCE 6-6-1996.

JERI J. FICKES, EXAMINING ATTORNEY

CLASS 9—(Continued).

SN 85-447,006. BYUCKSAN POWER US, INC., LOS AN-
GELES, CA. FILED 10-13-2011.

THE COLOR(S) BLACK AND RED IS/ARE CLAIMED AS
A FEATURE OF THE MARK.

THE MARK CONSISTS OF THE STYLIZED WORD
"ENERGLE" IN BLACK, WITH A TRIANGLE IN RED TO
THE UPPER RIGHT OF THE LAST "E" IN THE MARK.

THE WORDING "ENERGLE" HAS NO MEANING IN A
FOREIGN LANGUAGE.

FOR BUILDING ENERGY MANAGEMENT SYSTEMS
COMPRISING SOFTWARE AND HARDWARE FOR
PROVIDING PICTURE, VIDEO, ALARM STATUS,
BUILDING PLANS, AND OTHER INFORMATION TO A
REMOTE STATION; COMPUTER APPLICATION SOFT-
WARE FOR MOBILE PHONES, NAMELY, GRAPHICS
SOFTWARE FOR USE IN A BUILDING ENERGY
MANAGEMENT SYSTEM; COMPUTER HARDWARE
AND SOFTWARE SYSTEM FOR MONITORING BUILD-
ING ENERGY CONSUMPTION CONDITIONS AND
CONTROLLING DEVICES WITHIN A BUILDING, FAC-
ILITY, GROUNDS, OR DESIGNATED SPATIAL AREA;
COMPUTER SOFTWARE FOR MONITORING AND
CONTROLLING BUILDING ENERGY CONSUMPTION
(U.S. CLS. 21, 23, 26, 36 AND 38).

FIRST USE 10-31-2009; IN COMMERCE 3-2-2011.

JERI J. FICKES, EXAMINING ATTORNEY

SN 85-447,018. TRI-TRONICS COMPANY, INC., TAMPA, FL.
FILED 10-13-2011.

VISIONEYE

THE MARK CONSISTS OF STANDARD CHARACTERS
WITHOUT CLAIM TO ANY PARTICULAR FONT, STYLE,
SIZE, OR COLOR.

FOR PHOTOELECTRIC SENSORS (U.S. CLS. 21, 23, 26,
36 AND 38).

FIRST USE 3-27-1990; IN COMMERCE 3-27-1990.

RONALD MCMORROW, EXAMINING ATTORNEY

CLASS 9—(Continued).

SN 85-447,127. ACTIVE NOW, INC., PALO ALTO, CA. FILED 10-13-2011.

TeamOn

THE MARK CONSISTS OF STANDARD CHARACTERS WITHOUT CLAIM TO ANY PARTICULAR FONT, STYLE, SIZE, OR COLOR.

FOR COMPUTER APPLICATION SOFTWARE FOR MOBILE PHONES, NAMELY, SOFTWARE FOR USE IN ORGANIZING AND PARTICIPATING IN TEAM ACTIVITIES AROUND YOU AT A GIVEN TIME (U.S. CLS. 21, 23, 26, 36 AND 38).

NAPOLEON SHARMA, EXAMINING ATTORNEY

CLASS 9—(Continued).

SN 85-447,183. OCEANHOUSE MEDIA, INC., ENCINITAS, CA. FILED 10-13-2011.



THE MARK CONSISTS OF A SLOPING ELEMENT IN A SQUARE WITH ROUNDED CORNERS.

FOR DOWNLOADABLE SOFTWARE IN THE NATURE OF A MOBILE PHONE APPLICATION FOR DISPLAYING AND PLAYING ELECTRONIC BOOKS, ENTERTAINMENT CONTENT, MUSIC, VIDEO CLIPS AND GRAPHICS (U.S. CLS. 21, 23, 26, 36 AND 38).

FIRST USE 3-29-2009; IN COMMERCE 3-29-2009.
FONG HSU, EXAMINING ATTORNEY

SN 85-447,189. OCEANHOUSE MEDIA, INC., SAN DIEGO, CA. FILED 10-13-2011.

SN 85-447,180. MODULAR MINING SYSTEMS, INC., TUCSON, AZ. FILED 10-13-2011.

MINE SMARTER

THE MARK CONSISTS OF STANDARD CHARACTERS WITHOUT CLAIM TO ANY PARTICULAR FONT, STYLE, SIZE, OR COLOR.

OWNER OF U.S. REG. NO. 3,987,229.
NO CLAIM IS MADE TO THE EXCLUSIVE RIGHT TO USE "MINE", APART FROM THE MARK AS SHOWN.

FOR KNOWLEDGE-BASED SOLUTIONS, CONSISTING OF SOFTWARE AND COMPUTER HARDWARE, FOR MANAGING MINING FLEETS AND OPTIMIZING PRODUCTIVITY (U.S. CLS. 21, 23, 26, 36 AND 38).

FONG HSU, EXAMINING ATTORNEY



THE COLOR(S) BLUE IS/ARE CLAIMED AS A FEATURE OF THE MARK.

THE MARK CONSISTS OF A SLOPING ELEMENT IN A SQUARE WITH ROUNDED CORNERS, ALL IN BLUE
FOR DOWNLOADABLE SOFTWARE IN THE NATURE OF A MOBILE PHONE APPLICATION FOR DISPLAYING AND PLAYING ELECTRONIC BOOKS, ENTERTAINMENT CONTENT, MUSIC, VIDEO CLIPS AND GRAPHICS (U.S. CLS. 21, 23, 26, 36 AND 38).

FIRST USE 3-29-2009; IN COMMERCE 3-29-2009.
FONG HSU, EXAMINING ATTORNEY

CLASS 9—(Continued).

SN 85-447,230. TWENTIETH CENTURY FOX FILM CORPORATION, LOS ANGELES, CA. FILED 10-13-2011.

THE FINDER

THE MARK CONSISTS OF STANDARD CHARACTERS WITHOUT CLAIM TO ANY PARTICULAR FONT, STYLE, SIZE, OR COLOR.

FOR PRE-RECORDED DVDS FEATURING DRAMA; PRE-RECORDED CDS FEATURING DRAMA AND MUSICAL PERFORMANCES; DOWNLOADABLE AUDIO AND VIDEO RECORDINGS FEATURING DRAMA; DOWNLOADABLE TELEVISION SHOWS AND VIDEO RECORDINGS FEATURING DRAMA; DOWNLOADABLE RING TONES, GRAPHICS, COMPUTER DESKTOP WALLPAPER, GAMES AND MUSIC VIA A GLOBAL COMPUTER NETWORK AND WIRELESS DEVICES; COMPUTER SCREEN SAVER SOFTWARE; COMPUTER GAME AND VIDEO GAME SOFTWARE; MOUSEPADS; DECORATIVE MAGNETS; EYE GLASSES; HAND-HELD UNITS FOR PLAYING ELECTRONIC GAMES FOR USE WITH EXTERNAL DISPLAY SCREEN OR MONITOR (U.S. CLS. 21, 23, 26, 36 AND 38).

JANICE L. MCMORROW, EXAMINING ATTORNEY

CLASS 9—(Continued).

SN 85-447,415. GYRODATA INCORPORATED, HOUSTON, TX. FILED 10-14-2011.

MXY

THE MARK CONSISTS OF STANDARD CHARACTERS WITHOUT CLAIM TO ANY PARTICULAR FONT, STYLE, SIZE, OR COLOR.

FOR GYROSCOPIC WELLBORE MEASUREMENT SENSOR, NAMELY GYROSCOPE SENSOR FOR MEASURING DIRECTION AND ORIENTATION OF A WELLBORE FOR THE OIL AND GAS, ENERGY, MINING, ENVIRONMENTAL AND CONSTRUCTION INDUSTRIES; DOWN HOLE GYROSCOPIC MEASUREMENT SENSOR FOR OBTAINING DIRECTIONAL DRILLING CONTROL DATA FOR USE BY OTHERS FOR CONTROLLING THE DIRECTION OF WELLBORE DRILLING IN THE OIL AND GAS, ENERGY, MINING, ENVIRONMENTAL AND CONSTRUCTION INDUSTRIES (U.S. CLS. 21, 23, 26, 36 AND 38).

FIRST USE 2-21-2011; IN COMMERCE 2-21-2011.

RUSS HERMAN, EXAMINING ATTORNEY

SN 85-447,433. COMPLEX MEDIA, INC., NEW YORK, NY. FILED 10-14-2011.

NTR SCTN

THE MARK CONSISTS OF STANDARD CHARACTERS WITHOUT CLAIM TO ANY PARTICULAR FONT, STYLE, SIZE, OR COLOR.

FOR DOWNLOADABLE SOFTWARE IN THE NATURE OF A MOBILE APPLICATION THAT ENABLES USERS TO UPLOAD, POST, SHOW, VIEW, DISPLAY, CATEGORIZE, SEARCH, DOWNLOAD, RATE, COMMENT UPON, STORE, TAG, BLOG, AND SHARE NEWS STORIES AND ARTICLES IN THE FIELDS OF PERSONAL STYLE, SHOPPING, MUSIC, ART, GAMING, CLOTHING, ENTERTAINMENT AND SPORTS, AND THEN RANKS AND SORTS THE NEWS STORIES AND ARTICLES BASED UPON POPULARITY AND RELEVANCE, TRACK WEB SITE USER ACTIVITY, DELIVER TARGETED DATA AND INFORMATION TO WEB SITE USERS BASED ON AMBIENT, BEHAVIORAL, OR EXPLICITLY PROVIDED DATA, MEASURE AND TEST USER AFFINITY FOR MATERIAL AND CONTENT ALTERNATIVES, AND CAPTURE AND REPORT ON DATA SUBMITTED BY WEB SITE USERS VIA THE APPLICATION (U.S. CLS. 21, 23, 26, 36 AND 38).

WILLIAM JACKSON, EXAMINING ATTORNEY

SN 85-447,380. BOSSY BOOTS, LLC, SAN RAFAEL, CA. FILED 10-14-2011.

MAYFLY

THE MARK CONSISTS OF STANDARD CHARACTERS WITHOUT CLAIM TO ANY PARTICULAR FONT, STYLE, SIZE, OR COLOR.

FOR DOWNLOADABLE SOFTWARE IN THE NATURE OF A MOBILE APPLICATION FOR DISPLAYING AND SHARING A USER'S LOCATION AND FINDING, LOCATING, AND INTERACTING WITH OTHER USERS AND PLACES (U.S. CLS. 21, 23, 26, 36 AND 38).

DAVID HOFFMAN, EXAMINING ATTORNEY

CLASS 9—(Continued).

SN 85-447,449. AMS-TAOS USA INC., FORMERLY TEXAS ADVANCED OPTOELECTRONIC SOLUTIONS, PLANO, TX. FILED 10-14-2011.

AMS-TAOS

THE MARK CONSISTS OF STANDARD CHARACTERS WITHOUT CLAIM TO ANY PARTICULAR FONT, STYLE, SIZE, OR COLOR.

OWNER OF U.S. REG. NO. 2,497,840.
FOR MIXED SIGNAL SEMICONDUCTORS (U.S. CLS. 21, 23, 26, 36 AND 38).
KATHERINE CHANG, EXAMINING ATTORNEY

SN 85-447,462. AMS-TAOS USA INC., FORMERLY TEXAS ADVANCED OPTOELECTRONIC SOLUTIONS, PLANO, TX. FILED 10-14-2011.

AMS-TAOS USA

THE MARK CONSISTS OF STANDARD CHARACTERS WITHOUT CLAIM TO ANY PARTICULAR FONT, STYLE, SIZE, OR COLOR.

OWNER OF U.S. REG. NO. 2,497,840.
NO CLAIM IS MADE TO THE EXCLUSIVE RIGHT TO USE "USA", APART FROM THE MARK AS SHOWN.
FOR MIXED SIGNAL SEMICONDUCTORS (U.S. CLS. 21, 23, 26, 36 AND 38).
KATHERINE CHANG, EXAMINING ATTORNEY

SN 85-447,565. HTC CORPORATION, TAOYUAN CITY, TAIWAN, FILED 10-14-2011.

HTC EVO 4G

THE MARK CONSISTS OF STANDARD CHARACTERS WITHOUT CLAIM TO ANY PARTICULAR FONT, STYLE, SIZE, OR COLOR.

OWNER OF U.S. REG. NOS. 3,532,002, 4,071,994 AND OTHERS.
NO CLAIM IS MADE TO THE EXCLUSIVE RIGHT TO USE "4G", APART FROM THE MARK AS SHOWN.
FOR MOBILE PHONES, SMARTPHONES AND CELLULAR PHONES (U.S. CLS. 21, 23, 26, 36 AND 38).
FIRST USE 3-23-2010; IN COMMERCE 3-23-2010.
MEGHAN REINHART, EXAMINING ATTORNEY

CLASS 9—(Continued).

SN 85-447,572. S.P.I.C. ENTERTAINMENT, LLC, MAITLAND, FL. FILED 10-14-2011.

SPICILICIOUS

THE MARK CONSISTS OF STANDARD CHARACTERS WITHOUT CLAIM TO ANY PARTICULAR FONT, STYLE, SIZE, OR COLOR.

FOR PRERECORDED VIDEO TAPES AND CASSETTES, MULTIMEDIA CD-ROMS AND DISCS, DIGITAL VIDEO DISCS AND COMPUTER SOFTWARE, FEATURING ENTERTAINMENT IN THE NATURE OF FICTIONAL AND NON-FICTIONAL MOTION PICTURES, MUSIC VIDEOS, ANIMATED CARTOONS, LIVE MUSIC CONCERTS, THEATRICAL PERFORMANCES, MUSICAL PERFORMANCES, DANCE PERFORMANCES, COMEDY SHOWS, CONTINUING MUSIC, COMEDY, AND VARIETY SHOWS BROADCAST OVER TELEVISION OR THE INTERNET AND PERFORMANCES BY AMATEUR AND PROFESSIONAL ENTERTAINERS AND ARTISTS; DOWNLOADABLE AUDIO FILES, MUSICAL SOUND RECORDINGS, MULTIMEDIA FILES, VIDEO FILES, TEXT FILES, AUDIO MATERIAL AND VIDEO MATERIAL DELIVERED BY THE INTERNET, ALL FEATURING ENTERTAINMENT IN THE NATURE OF FICTIONAL AND NON-FICTIONAL MOTION PICTURES, MUSIC VIDEOS, ANIMATED CARTOONS, LIVE MUSIC CONCERTS, MUSICAL PERFORMANCES, THEATRICAL PERFORMANCES, DANCE PERFORMANCES, COMEDY SHOWS, CONTINUING MUSIC, COMEDY, AND VARIETY SHOWS; AND INTERACTIVE VIDEO GAME PROGRAMS; VIDEO GAME DISCS AND DOWNLOADABLE VIDEO GAME SOFTWARE (U.S. CLS. 21, 23, 26, 36 AND 38).
CHRISTINA SOBRAL, EXAMINING ATTORNEY

SN 85-447,580. JSMG WORLDWIDE, INC, MIRAMAR, FL. FILED 10-14-2011.

GALAXIER

THE MARK CONSISTS OF STANDARD CHARACTERS WITHOUT CLAIM TO ANY PARTICULAR FONT, STYLE, SIZE, OR COLOR.

FOR AUDIO HEADPHONES (U.S. CLS. 21, 23, 26, 36 AND 38).
MEGHAN REINHART, EXAMINING ATTORNEY

CLASS 9—(Continued).

SN 85-447,610. GLOBE FOOD EQUIPMENT COMPANY,
DAYTON, OH. FILED 10-14-2011.

GLOBE

THE MARK CONSISTS OF STANDARD CHARACTERS
WITHOUT CLAIM TO ANY PARTICULAR FONT, STYLE,
SIZE, OR COLOR.

OWNER OF U.S. REG. NOS. 2,504,703 AND 2,789,358.
FOR SCALES, WEIGHING SCALES, CALCULATING
SCALES, SCALES FOR PORTION CONTROL AND COM-
PUTING PRICES (U.S. CLS. 21, 23, 26, 36 AND 38).
FIRST USE 2-28-2011; IN COMMERCE 2-28-2011.
AMY C. KEAN, EXAMINING ATTORNEY

SN 85-447,673. AVOX SYSTEMS INC., LANCASTER, NY.
FILED 10-14-2011.

INFINIOX

THE MARK CONSISTS OF STANDARD CHARACTERS
WITHOUT CLAIM TO ANY PARTICULAR FONT, STYLE,
SIZE, OR COLOR.

FOR SAFETY EQUIPMENT, NAMELY, A GENERAL
AVIATION ON-BOARD OXYGEN GENERATOR SYS-
TEM CONSISTING OF AN OXYGEN GENERATOR,
SENSOR MODULE, MANIFOLD WITH OUTLETS AND
AN OXYGEN MASK (U.S. CLS. 21, 23, 26, 36 AND 38).
LINDA M. KING, EXAMINING ATTORNEY

SN 85-447,680. BIG SWITCH NETWORKS, INC., PALO ALTO,
CA. FILED 10-14-2011.

FLOODLIGHT

THE MARK CONSISTS OF STANDARD CHARACTERS
WITHOUT CLAIM TO ANY PARTICULAR FONT, STYLE,
SIZE, OR COLOR.

FOR COMPUTER SOFTWARE AND COMPUTER
HARDWARE FOR CONTROLLING AND MODIFYING
THE BEHAVIOR OF NETWORK COMPONENTS, DE-
VICES AND APPLICATIONS (U.S. CLS. 21, 23, 26,
36 AND 38).

CHRISTINA SOBRAL, EXAMINING ATTORNEY

CLASS 9—(Continued).

SN 85-447,696. REVEILLE INDEPENDENT LLC, LOS AN-
GELES, CA. FILED 10-14-2011.

SAVING AMERICA

THE MARK CONSISTS OF STANDARD CHARACTERS
WITHOUT CLAIM TO ANY PARTICULAR FONT, STYLE,
SIZE, OR COLOR.

FOR PRE-RECORDED DVDS FEATURING TELEVI-
SION GAME SHOWS; PRE-RECORDED CDS FEATUR-
ING MUSIC FROM TELEVISION GAME SHOWS AND
MUSICAL PERFORMANCES; DOWNLOADABLE AUDIO
AND VIDEO RECORDINGS FEATURING TELEVISION
GAME SHOWS; DOWNLOADABLE TELEVISION SHOWS
AND VIDEO RECORDINGS FEATURING TELEVISION
GAME SHOWS; DOWNLOADABLE RING TONES, RING
BACKS, GRAPHICS, WALLPAPER, GAMES AND MUSIC
VIA A GLOBAL COMPUTER NETWORK AND WIRE-
LESS DEVICES; COMPUTER SCREEN SAVER SOFT-
WARE; COMPUTER GAME AND VIDEO GAME
SOFTWARE; MOUSEPADS; DECORATIVE MAGNETS
(U.S. CLS. 21, 23, 26, 36 AND 38).

WILLIAM P. SHANAHAN, EXAMINING ATTORNEY

SN 85-447,766. INCREDIBLE TECHNOLOGIES, INC., AR-
LINGTON HEIGHTS, IL. FILED 10-14-2011.

CRAZY MONEY

THE MARK CONSISTS OF STANDARD CHARACTERS
WITHOUT CLAIM TO ANY PARTICULAR FONT, STYLE,
SIZE, OR COLOR.

NO CLAIM IS MADE TO THE EXCLUSIVE RIGHT TO
USE "MONEY", APART FROM THE MARK AS SHOWN.

FOR GAMING MACHINES, NAMELY, SLOT MA-
CHINES AND VIDEO LOTTERY TERMINALS; GAMING
MACHINES, NAMELY, ELECTRONIC SLOT AND BIN-
GO MACHINES (U.S. CLS. 21, 23, 26, 36 AND 38).

FIRST USE 10-1-2007; IN COMMERCE 11-1-2007.

DEIRDRE ROBERTSON, EXAMINING ATTORNEY

CLASS 9—(Continued).

SN 85-447,840. TELINEAGE, INC., DBA PINDROP SECURITY, ATLANTA, GA. FILED 10-14-2011.

PINDROP

THE MARK CONSISTS OF STANDARD CHARACTERS WITHOUT CLAIM TO ANY PARTICULAR FONT, STYLE, SIZE, OR COLOR.

FOR COMPUTER SOFTWARE FOR AUTHENTICATION AND/OR FRAUD PREVENTION FOR PHONE CALLS; COMPUTER SOFTWARE FOR ENCRYPTION AND DECRYPTION; COMPUTER SOFTWARE PLATFORMS FOR AUTHENTICATION AND/OR FRAUD PREVENTION FOR PHONE CALLS; COMPUTER TELEPHONY SOFTWARE FOR AUTHENTICATION AND/OR FRAUD PREVENTION FOR PHONE CALLS; COMPUTER SOFTWARE THAT PROVIDES WEB-BASED ACCESS TO APPLICATIONS AND SERVICES THROUGH A WEB OPERATING SYSTEM OR PORTAL INTERFACE; DOWNLOADABLE COMPUTER SOFTWARE FOR USE IN AUTHENTICATION AND/OR FRAUD PREVENTION FOR PHONE CALLS (U.S. CLS. 21, 23, 26, 36 AND 38).

ALYSSA STEEL, EXAMINING ATTORNEY

CLASS 9—(Continued).

SN 85-447,873. BRUKER NANO, INC., SANTA BARBARA, CA. FILED 10-14-2011.

AUTOMET

THE MARK CONSISTS OF STANDARD CHARACTERS WITHOUT CLAIM TO ANY PARTICULAR FONT, STYLE, SIZE, OR COLOR.

FOR SOFTWARE FOR METROLOGY TOOLS, NAMELY, ANALYSIS SOFTWARE FOR ATOMIC FORCE MICROSCOPES (U.S. CLS. 21, 23, 26, 36 AND 38).

SUSAN LESLIE DUBOIS, EXAMINING ATTORNEY

SN 85-447,879. D-LINK SYSTEMS, INC., FOUNTAIN VALLEY, CA. FILED 10-14-2011.

MovieNite

THE MARK CONSISTS OF STANDARD CHARACTERS WITHOUT CLAIM TO ANY PARTICULAR FONT, STYLE, SIZE, OR COLOR.

FOR DIGITAL MEDIA STREAMING DEVICE (U.S. CLS. 21, 23, 26, 36 AND 38).

PATRICIA EVANKO, EXAMINING ATTORNEY

SN 85-447,843. MARSHALL, AL-KASHIF MAHARBA HAJILE, AKA TRE ACE, MONROVIA, CA. FILED 10-14-2011.

Tre Ace

THE MARK CONSISTS OF STANDARD CHARACTERS WITHOUT CLAIM TO ANY PARTICULAR FONT, STYLE, SIZE, OR COLOR.

FOR DIGITAL PHOTO FRAMES FOR DISPLAYING DIGITAL PICTURES, VIDEO CLIPS AND MUSIC; DOWNLOADABLE MP3 FILES, MP3 RECORDINGS, ON-LINE DISCUSSION BOARDS, WEBCASTS, WEBINARS AND PODCASTS FEATURING MUSIC, AUDIO BOOKS IN THE FIELD OF MUSIC, AND NEWS BROADCASTS; DOWNLOADABLE MUSICAL SOUND RECORDINGS; DOWNLOADABLE RING TONES, GRAPHICS AND MUSIC VIA A GLOBAL COMPUTER NETWORK AND WIRELESS DEVICES; DOWNLOADABLE VIDEO RECORDINGS FEATURING MUSIC; DOWNLOADABLE MUSIC VIA THE INTERNET AND WIRELESS DEVICES; MUSICAL RECORDINGS; MUSICAL SOUND RECORDINGS; MUSICAL VIDEO RECORDINGS; SERIES OF MUSICAL SOUND RECORDINGS; SOUND RECORDINGS FEATURING MUSIC; VIDEO RECORDINGS FEATURING MUSIC; VISUAL RECORDINGS AND AUDIOVISUAL RECORDINGS FEATURING MUSIC AND ANIMATION (U.S. CLS. 21, 23, 26, 36 AND 38).

FIRST USE 10-10-1993; IN COMMERCE 11-11-1996.
SUSAN LESLIE DUBOIS, EXAMINING ATTORNEY

SN 85-447,913. MEMC ELECTRONIC MATERIALS, INC., ST. PETERS, MO. FILED 10-14-2011.

SILVANTIS

THE MARK CONSISTS OF STANDARD CHARACTERS WITHOUT CLAIM TO ANY PARTICULAR FONT, STYLE, SIZE, OR COLOR.

FOR PHOTOVOLTAIC SOLAR MODULES FOR PRODUCTION OF ELECTRICITY (U.S. CLS. 21, 23, 26, 36 AND 38).

ALICE BENMAMAN, EXAMINING ATTORNEY

CLASS 9—(Continued).

SN 85-447,929. AMPT, LLC, FORT COLLINS, CO. FILED 10-14-2011.

AMPT MODE

THE MARK CONSISTS OF STANDARD CHARACTERS WITHOUT CLAIM TO ANY PARTICULAR FONT, STYLE, SIZE, OR COLOR.

OWNER OF U.S. REG. NOS. 3,862,127 AND 3,865,902. FOR SOLAR POWER SYSTEMS AND COMPONENTS; PHOTOVOLTAIC SOLAR MODULES; SOFTWARE FOR MANAGING SOLAR POWER AND PHOTOVOLTAIC SOLAR MODULES; DESIGN OF SOLAR POWER SYSTEMS AND COMPONENTS AND PHOTOVOLTAIC SOLAR MODULES MANAGING SOLAR POWER (U.S. CLS. 21, 23, 26, 36 AND 38).

RAUL CORDOVA, EXAMINING ATTORNEY

SN 85-447,977. FRANK LEE IMPORTS LTD., BALDWIN PARK, CA. FILED 10-14-2011.

TAKE IT WITH YOU

THE MARK CONSISTS OF STANDARD CHARACTERS WITHOUT CLAIM TO ANY PARTICULAR FONT, STYLE, SIZE, OR COLOR.

FOR AUDIO SPEAKERS (U.S. CLS. 21, 23, 26, 36 AND 38).

JOHN GARTNER, EXAMINING ATTORNEY

SN 85-448,216. SAGAR, VINOD, CORONA, CA. FILED 10-14-2011.

WOPAD

THE MARK CONSISTS OF STANDARD CHARACTERS WITHOUT CLAIM TO ANY PARTICULAR FONT, STYLE, SIZE, OR COLOR.

FOR TABLET COMPUTER (U.S. CLS. 21, 23, 26, 36 AND 38).

FIRST USE 3-1-2011; IN COMMERCE 8-1-2011. JAY BESCH, EXAMINING ATTORNEY

CLASS 9—(Continued).

SN 85-448,228. HARVARD APPARATUS, INC., HOLLISTON, MA. FILED 10-14-2011.

ADAGIO

THE MARK CONSISTS OF STANDARD CHARACTERS WITHOUT CLAIM TO ANY PARTICULAR FONT, STYLE, SIZE, OR COLOR.

FOR COMPUTER APPLICATION SOFTWARE, NAMELY, SOFTWARE FOR CONTROL OF MEDICAL AND RESEARCH LABORATORY APPARATUS, NAMELY SYRINGE PUMPS, AND USER'S MANUALS SOLD AS A UNIT (U.S. CLS. 21, 23, 26, 36 AND 38).

FIRST USE 7-31-2010; IN COMMERCE 7-31-2010.

KRISTIN DAHLING, EXAMINING ATTORNEY

SN 85-448,241. HARVARD APPARATUS, INC., HOLLISTON, MA. FILED 10-14-2011.

EZ PRO

THE MARK CONSISTS OF STANDARD CHARACTERS WITHOUT CLAIM TO ANY PARTICULAR FONT, STYLE, SIZE, OR COLOR.

FOR COMPUTER APPLICATION SOFTWARE, NAMELY, SOFTWARE FOR CONTROL OF MEDICAL AND RESEARCH LABORATORY APPARATUS, NAMELY SYRINGE PUMPS, AND USER'S MANUALS SOLD AS A UNIT (U.S. CLS. 21, 23, 26, 36 AND 38).

FIRST USE 7-31-2009; IN COMMERCE 7-31-2009.

KRISTIN DAHLING, EXAMINING ATTORNEY

SN 85-448,246. DYNON INSTRUMENTS, INC., WOODINVILLE, WA. FILED 10-14-2011.

GROWPAK

THE MARK CONSISTS OF STANDARD CHARACTERS WITHOUT CLAIM TO ANY PARTICULAR FONT, STYLE, SIZE, OR COLOR.

FOR ELECTRONIC CONTROLLERS FOR CONTROLLING TEMPERATURE, PH, HUMIDITY, CARBON DIOXIDE AND OTHER PARAMETERS THAT AFFECT THE GROWTH OF PLANT LIFE AND THE ENVIRONMENTS IN WHICH THEY GROW; PROGRAMMABLE ELECTRONIC CONTROLLERS FOR CONTROLLING TEMPERATURE, PH, HUMIDITY, CARBON DIOXIDE AND OTHER PARAMETERS THAT AFFECT THE GROWTH OF PLANT LIFE AND THE ENVIRONMENTS IN WHICH THEY GROW (U.S. CLS. 21, 23, 26, 36 AND 38).

FIRST USE 6-1-2011; IN COMMERCE 6-1-2011.

KATINA MISTER, EXAMINING ATTORNEY

CLASS 9—(Continued).

SN 85-448,357. PHAERON, INC., BROOMFIELD, CO. FILED 10-15-2011.

GoDAQ

THE MARK CONSISTS OF STANDARD CHARACTERS WITHOUT CLAIM TO ANY PARTICULAR FONT, STYLE, SIZE, OR COLOR.

FOR COMPUTER HARDWARE AND SOFTWARE SYSTEMS FOR USE IN THE COLLECTION AND MEASUREMENT OF ENGINEERING, SCIENTIFIC AND INDUSTRIAL AUTOMATION INPUT/OUTPUT SIGNALS (U.S. CLS. 21, 23, 26, 36 AND 38).

ANNE FARRELL, EXAMINING ATTORNEY

SN 85-448,379. RICHARD SEAN STRUBBE, CHESAPEAKE, VA. FILED 10-16-2011.



THE COLOR(S) ORANGE, GREEN, GRAY, BLUE IS/ARE CLAIMED AS A FEATURE OF THE MARK.

THE MARK CONSISTS OF FOUR ICONS THAT REPRESENT PEOPLE; ONE ICON THAT REPRESENTS A PERSON IS ORANGE IN COLOR, ANOTHER ICON THAT REPRESENTS A PERSON IS GRAY IN COLOR, ANOTHER ICON THAT REPRESENTS A PERSON IS BLUE IN COLOR, AND THE LAST ICON THAT REPRESENTS A PERSON IS GREEN IN COLOR. THE FOUR ICONS THAT REPRESENT PEOPLE ARE LOCATED TO THE LEFT OF THE WORDS "EXPLORE INQUIRE CONNECT". THE WORD "EXPLORE" IS WRITTEN IN ORANGE WITH A CAPITAL "E". THE WORDS "INQUIRE" AND "CONNECT" ARE WRITTEN IN BLUE AND CAN BE FOUND UNDER THE WORD "EXPLORE" AND START WITH CAPITAL LETTERS ("I" IN "INQUIRE" IS CAPITALIZED AND "C" IN "CONNECT" IS CAPITALIZED).

FOR COMPUTER APPLICATION SOFTWARE FOR MOBILE PHONES, NAMELY, SOFTWARE FOR NETWORKING AND ADVERTISING (U.S. CLS. 21, 23, 26, 36 AND 38).

THOMAS MANOR, EXAMINING ATTORNEY

SN 85-448,394. BECKER, GREGORY R., CHAPEL HILL, NC. FILED 10-16-2011.

weDJ

THE MARK CONSISTS OF STANDARD CHARACTERS WITHOUT CLAIM TO ANY PARTICULAR FONT, STYLE, SIZE, OR COLOR.

FOR COMPUTER APPLICATION SOFTWARE FOR MOBILE PHONES, NAMELY, SOFTWARE FOR STREAMING, SHARING, AND LISTENING TO MUSIC AMONG USERS (U.S. CLS. 21, 23, 26, 36 AND 38).

MICHAEL W. BAIRD, EXAMINING ATTORNEY

CLASS 9—(Continued).

SN 85-448,425. TIM SVEHAUG, COLORADO SPRINGS, CO. FILED 10-16-2011.

22 BONES

THE MARK CONSISTS OF STANDARD CHARACTERS WITHOUT CLAIM TO ANY PARTICULAR FONT, STYLE, SIZE, OR COLOR.

FOR PROTECTIVE HELMETS (U.S. CLS. 21, 23, 26, 36 AND 38).

MICHAEL WEBSTER, EXAMINING ATTORNEY

SN 85-448,551. COSA INSTRUMENT CORPORATION, YAPHANK, NY. FILED 10-17-2011.

SPINPULSE

THE MARK CONSISTS OF STANDARD CHARACTERS WITHOUT CLAIM TO ANY PARTICULAR FONT, STYLE, SIZE, OR COLOR.

FOR SPECTROMETERS AND PARTS AND FITTINGS THEREFOR (U.S. CLS. 21, 23, 26, 36 AND 38).

SUZANNE BLANE, EXAMINING ATTORNEY

SN 85-448,566. AMERICAN HEADACHE SOCIETY, MT. ROYAL, NJ. FILED 10-17-2011.

ACHE

THE MARK CONSISTS OF STANDARD CHARACTERS WITHOUT CLAIM TO ANY PARTICULAR FONT, STYLE, SIZE, OR COLOR.

OWNER OF U.S. REG. NO. 1,721,816.

FOR DOWNLOADABLE ELECTRONIC PUBLICATIONS, NAMELY, A SERIALY PUBLISHED NEWSLETTER IN THE FIELD OF HEADACHE (U.S. CLS. 21, 23, 26, 36 AND 38).

FIRST USE 2-27-2009; IN COMMERCE 2-27-2009.

NAKIA HENRY, EXAMINING ATTORNEY

CLASS 9—(Continued).

SN 85-448,620. FIJI SOLUTIONS, LLC, BALTIMORE, MD.
FILED 10-17-2011.



THE COLOR(S) RED, WHITE, BLACK IS/ARE CLAIMED AS A FEATURE OF THE MARK.

THE MARK CONSISTS OF THE LETTER "Z" IN RED AND THE LETTER "H" IN WHITE OVERLAPPING IN THE CENTER OF A BLACK RECTANGULAR BACKGROUND. IN MULTIPLE PLACES THERE ARE RED SPLATTER DROPS ON THE BLACK BACKGROUND.

FOR COMPUTER GAME SOFTWARE; COMPUTER GAME SOFTWARE DOWNLOADABLE FROM A GLOBAL COMPUTER NETWORK; COMPUTER GAME SOFTWARE FOR USE ON MOBILE AND CELLULAR PHONES; DOWNLOADABLE COMPUTER GAME SOFTWARE VIA A GLOBAL COMPUTER NETWORK AND WIRELESS DEVICES; ELECTRONIC GAME SOFTWARE; ELECTRONIC GAME SOFTWARE FOR CELLULAR TELEPHONES; ELECTRONIC GAME SOFTWARE FOR HANDHELD ELECTRONIC DEVICES; ELECTRONIC GAME SOFTWARE FOR WIRELESS DEVICES; GAME SOFTWARE; VIDEO GAME SOFTWARE (U.S. CLS. 21, 23, 26, 36 AND 38).

CORY BOONE, EXAMINING ATTORNEY

SN 85-448,636. LANDMARK GRAPHICS CORPORATION,
HOUSTON, TX. FILED 10-17-2011.

DYNAMIC FRAMEWORKS TO FILL

THE MARK CONSISTS OF STANDARD CHARACTERS WITHOUT CLAIM TO ANY PARTICULAR FONT, STYLE, SIZE, OR COLOR.

FOR COMPUTER SOFTWARE FOR SEISMIC INTERPRETATION, MAPPING AND MODELING TO ACQUIRE SEISMIC DATA FOR USE IN THE EXPLORATION AND PRODUCTION OF HYDROCARBONS (U.S. CLS. 21, 23, 26, 36 AND 38).

HANNO RITTNER, EXAMINING ATTORNEY

CLASS 9—(Continued).

SN 85-448,639. SECURESIGHT INTERNATIONAL LTD,
TEWKESBURY, UNITED KINGDOM, FILED 10-17-2011.

WE DO IT BETTER

THE MARK CONSISTS OF STANDARD CHARACTERS WITHOUT CLAIM TO ANY PARTICULAR FONT, STYLE, SIZE, OR COLOR.

FOR BUILDING SECURITY SYSTEMS COMPRISING SOFTWARE AND HARDWARE FOR PROVIDING PICTURE, VIDEO, ALARM STATUS, BUILDING PLANS, AND OTHER INFORMATION TO A REMOTE STATION; CLOSED CIRCUIT TV SYSTEMS FOR SECURITY AND SURVEILLANCE, NAMELY, CAMERAS, SWITCHERS, MONITORS, MICROPHONES, AND RECORDERS; ELECTRONIC VIDEO SURVEILLANCE PRODUCTS, NAMELY, ELECTRONIC COMPONENTS OF SECURITY SYSTEMS; MOTION SENSITIVE SECURITY LIGHTS; PERSONAL SECURITY ALARMS; SECURITY ALARM CONTROLLERS; SECURITY AND FIRE ALARMS; SECURITY CONTROL PANELS AND MOTION DETECTORS; SECURITY LIGHTS FOR OUTDOOR USE; SECURITY PRODUCTS, NAMELY, ENTRY DOOR SYSTEMS COMPRISING TOUCH PADS AND SECURITY DOORS (U.S. CLS. 21, 23, 26, 36 AND 38).

CHRIS WELLS, EXAMINING ATTORNEY

SN 85-448,745. GARY LEE FISHMAN, MANALAPAN, NJ.
FILED 10-17-2011.

SAFESTYLE

THE MARK CONSISTS OF STANDARD CHARACTERS WITHOUT CLAIM TO ANY PARTICULAR FONT, STYLE, SIZE, OR COLOR.

FOR COVERS FOR ELECTRIC OUTLETS (U.S. CLS. 21, 23, 26, 36 AND 38).

FIRST USE 10-12-2011; IN COMMERCE 10-12-2011.

MYRIAH HABEEB, EXAMINING ATTORNEY

CLASS 9—(Continued).

SN 85-448,797. ALETHEA AUSTIN LEMAN, LOS ANGELES, CA. FILED 10-17-2011.

Alethea Austin

THE MARK CONSISTS OF STANDARD CHARACTERS WITHOUT CLAIM TO ANY PARTICULAR FONT, STYLE, SIZE, OR COLOR.

THE NAME(S), PORTRAIT(S), AND/OR SIGNATURE(S) SHOWN IN THE MARK IDENTIFIES ALETHEA AUSTIN LEMAN, WHOSE CONSENT(S) TO REGISTER IS MADE OF RECORD.

FOR DIGITAL MEDIA, NAMELY, PRE-RECORDED VIDEO CASSETTES, DIGITAL VIDEO DISKS, DIGITAL VERSATILE DISCS, DOWNLOADABLE AUDIO AND VIDEO RECORDINGS, DVDS AND HIGH DEFINITION DISCS FEATURING FITNESS WORKOUTS FOR POLE DANCING (U.S. CLS. 21, 23, 26, 36 AND 38).

FIRST USE 4-1-2011; IN COMMERCE 4-1-2011.
COLLEEN DOMBROW, EXAMINING ATTORNEY



SN 85-448,923. PLANIT SOLUTIONS, INC., TUSCALOOSA, AL. FILED 10-17-2011.

Screen to Machine

THE MARK CONSISTS OF STANDARD CHARACTERS WITHOUT CLAIM TO ANY PARTICULAR FONT, STYLE, SIZE, OR COLOR.

FOR COMPUTER PROGRAMS, NAMELY, SOFTWARE DESIGNED TO DEVELOP AND PLAN CUSTOM CABINETS OR ARCHITECTURAL CASEWORK (U.S. CLS. 21, 23, 26, 36 AND 38).

FIRST USE 1-1-1999; IN COMMERCE 1-1-1999.
KATHY DE JONGE, EXAMINING ATTORNEY



SN 85-448,999. I22, LLC, ALISO VIEJO, CA. FILED 10-17-2011.

i22

THE MARK CONSISTS OF STANDARD CHARACTERS WITHOUT CLAIM TO ANY PARTICULAR FONT, STYLE, SIZE, OR COLOR.

FOR MEDICAL SOFTWARE FOR DATA COLLECTION AND USE FOR HOSPITALS AND SURGERY SUPPORT (U.S. CLS. 21, 23, 26, 36 AND 38).

JOHN HWANG, EXAMINING ATTORNEY

CLASS 9—(Continued).

SN 85-449,002. CINCOM SYSTEMS, INC., CINCINNATI, OH. FILED 10-17-2011.

NUTRI-TOUCH

THE MARK CONSISTS OF STANDARD CHARACTERS WITHOUT CLAIM TO ANY PARTICULAR FONT, STYLE, SIZE, OR COLOR.

FOR COMPUTER SOFTWARE APPLICATIONS FOR MOBILE DEVICES TO TRACK NUTRITIONAL, EXERCISE, WEIGHT AND MEDICATION INFORMATION (U.S. CLS. 21, 23, 26, 36 AND 38).

LINDA M. KING, EXAMINING ATTORNEY



SN 85-449,220. ANTELOPE WORKS, LLC, PHOENIX, AZ. FILED 10-17-2011.

THERASPECS

THE MARK CONSISTS OF STANDARD CHARACTERS WITHOUT CLAIM TO ANY PARTICULAR FONT, STYLE, SIZE, OR COLOR.

FOR EYEWEAR, NAMELY, SUNGLASSES, EYEGLASSES AND OPHTHALMIC FRAMES AND CASES THEREFOR (U.S. CLS. 21, 23, 26, 36 AND 38).

GEORGE LORENZO, EXAMINING ATTORNEY

CLASS 9—(Continued).

SN 85-449,302. INTEGRADORA DE PATENTES Y MARCAS, S. DE R.L. DE C.V., GUADALAJARA, JALISCO, MEXICO, FILED 10-17-2011.



OWNER OF MEXICO REG. NO. 1232571, DATED 8-11-2011, EXPIRES 4-1-2021.

THE MARK CONSISTS OF STYLIZED CHARACTERS OF THE LITERAL ELEMENT "CARTEK" WITH A BIG POINT IN THE CENTER OF THE LETTER "C".

FOR ACCUMULATORS AND BATTERIES; APPARATUS AND INSTRUMENTS FOR CONVEYING, DISTRIBUTING, TRANSFORMING, STORING, REGULATING OR CONTROLLING ELECTRIC CURRENT; APPARATUS AND INSTRUMENTS FOR WEIGHING; APPARATUS FOR RECORDING, TRANSMISSION OR REPRODUCTION OF SOUND AND IMAGES; AUTOMATIC VENDING MACHINES; AUTOMOTIVE MEASURING INSTRUMENTS, NAMELY, WATER TEMPERATURE GAUGES, AIR FUEL/RATIO GAUGES, BOOST GAUGES, VACUUM GAUGES AND EXHAUST GAS TEMPERATURE GAUGES; BATTERIES FOR VEHICLES; BLANK MAGNETIC DATA CARRIERS; CONTROLLED VOLUME PUMPS; ELECTRIC ACCUMULATORS FOR VEHICLES; ELECTRIC COILS; FUEL PUMP TESTERS; METERED GASOLINE PUMPS; TECHNICAL MEASURING, TESTING AND CHECKING APPARATUS AND INSTRUMENTS FOR MEASURING, TESTING AND CHECKING THE TEMPERATURE, PRESSURE, QUANTITY AND CONCENTRATION OF GAS AND LIQUIDS (U.S. CLS. 21, 23, 26, 36 AND 38).

PAUL E. FAHRENKOPF, EXAMINING ATTORNEY

SN 85-449,303. SWIPEROO, LLC, WESTPORT, CT. FILED 10-17-2011.



THE MARK CONSISTS OF THE STYLIZED TEXT "SWIPEROO" WITH A DOT OVER THE LETTER "I".

FOR COMPUTER APPLICATION SOFTWARE FOR MOBILE PHONES AND TABLET COMPUTERS, NAMELY, SOFTWARE FOR LEARNING GAMES FOR CHILDREN (U.S. CLS. 21, 23, 26, 36 AND 38).

PAUL E. FAHRENKOPF, EXAMINING ATTORNEY

CLASS 9—(Continued).

SN 85-449,325. VITASYS, INC., AKA VITASYS, REDMOND, WA. FILED 10-17-2011.



THE MARK CONSISTS OF STANDARD CHARACTERS WITHOUT CLAIM TO ANY PARTICULAR FONT, STYLE, SIZE, OR COLOR.

FOR DATABASE MANAGEMENT SOFTWARE FOR OUTBREAKS OF DISEASE AND HEALTH EVENTS (U.S. CLS. 21, 23, 26, 36 AND 38).

JACQUELINE A. LAVINE, EXAMINING ATTORNEY

SN 85-449,527. LET'S TALK ABOUT FOOD, LLC, CAMBRIDGE, MA. FILED 10-18-2011.

KITCHEN CONVERSATIONS

THE MARK CONSISTS OF STANDARD CHARACTERS WITHOUT CLAIM TO ANY PARTICULAR FONT, STYLE, SIZE, OR COLOR.

FOR AUDIO AND VIDEO RECORDINGS FEATURING INDIVIDUAL STORIES AND MEMORIES ABOUT FOOD (U.S. CLS. 21, 23, 26, 36 AND 38).

ELISSA GARBER KON, EXAMINING ATTORNEY

SN 85-449,562. REYNALDO V. ALONZO, FRESNO, CA. FILED 10-18-2011.

SCREENPRO

THE MARK CONSISTS OF STANDARD CHARACTERS WITHOUT CLAIM TO ANY PARTICULAR FONT, STYLE, SIZE, OR COLOR.

FOR A DEVICE FOR APPLYING SCREEN PROTECTORS TO PORTABLE ELECTRONIC DEVICES (U.S. CLS. 21, 23, 26, 36 AND 38).

FIRST USE 6-8-2011; IN COMMERCE 6-8-2011.

GRETTA YAO, EXAMINING ATTORNEY

CLASS 9—(Continued).

SN 85-449,929. TULL, JON, WESTLAKE VILLAGE, CA. FILED 10-18-2011.

**Social
Energy**

THE MARK CONSISTS OF STANDARD CHARACTERS WITHOUT CLAIM TO ANY PARTICULAR FONT, STYLE, SIZE, OR COLOR.

NO CLAIM IS MADE TO THE EXCLUSIVE RIGHT TO USE "ENERGY", APART FROM THE MARK AS SHOWN.

FOR COMPUTER SOFTWARE FOR USE IN FACILITATING SOCIAL NETWORKING FOR THE COLLECTION, SORTING AND ANALYZING OF UTILITY, ENERGY AND RESOURCE USAGE, CONSUMPTION AND CONSERVATION (U.S. CLS. 21, 23, 26, 36 AND 38).

KATHERINE STOIDES, EXAMINING ATTORNEY

SN 85-449,943. CHEERS CLUB CORPORATION, NEW YORK, NY. FILED 10-18-2011.



CHEERS CLUB

THE MARK CONSISTS OF TWO CHAMPAGNE GLASSES SURROUNDED BY LEAVES, AND THE TEXT "CHEERS CLUB" BELOW THE IMAGE.

FOR DIGITAL MEDIA, NAMELY, CDS, DVDS, AND DOWNLOADABLE AUDIO FILES FEATURING MUSIC (U.S. CLS. 21, 23, 26, 36 AND 38).

FIRST USE 3-1-2011; IN COMMERCE 3-1-2011.

CARRIE GENOVESE, EXAMINING ATTORNEY

CLASS 9—(Continued).

SN 85-449,950. FAIREY, SHEPARD, LOS ANGELES, CA. FILED 10-18-2011.

SHEPARD FAIREY

THE MARK CONSISTS OF STANDARD CHARACTERS WITHOUT CLAIM TO ANY PARTICULAR FONT, STYLE, SIZE, OR COLOR.

THE NAME(S), PORTRAIT(S), AND/OR SIGNATURE(S) SHOWN IN THE MARK IDENTIFIES "SHEPARD FAIREY", WHOSE CONSENT(S) TO REGISTER IS MADE OF RECORD.

FOR CASES FOR ELECTRONIC DIARIES; NOTEBOOK COMPUTER CARRYING CASES; PROTECTIVE COVERS AND CASES FOR CELL PHONES, LAPTOPS AND PORTABLE MEDIA PLAYERS (U.S. CLS. 21, 23, 26, 36 AND 38).

CHRISTOPHER LAW, EXAMINING ATTORNEY

SN 85-449,998. MAXENTRIC TECHNOLOGIES, LLC, FORT LEE, NJ. FILED 10-18-2011.

VIMESH

THE MARK CONSISTS OF STANDARD CHARACTERS WITHOUT CLAIM TO ANY PARTICULAR FONT, STYLE, SIZE, OR COLOR.

FOR MODEMS AND FREQUENCY TRANSLATOR COMPUTER PERIPHERALS OPERATING IN THE 57-64 GHZ ISM BAND FREQUENCY (U.S. CLS. 21, 23, 26, 36 AND 38).

FIRST USE 5-1-2011; IN COMMERCE 5-1-2011.

LINDA ESTRADA, EXAMINING ATTORNEY

SN 85-450,012. MAXENTRIC TECHNOLOGIES, LLC, FORT LEE, NJ. FILED 10-18-2011.

VIMAX

THE MARK CONSISTS OF STANDARD CHARACTERS WITHOUT CLAIM TO ANY PARTICULAR FONT, STYLE, SIZE, OR COLOR.

FOR MODEMS AND FREQUENCY TRANSLATOR COMPUTER PERIPHERALS OPERATING IN THE 57-64 GHZ ISM BAND FREQUENCY (U.S. CLS. 21, 23, 26, 36 AND 38).

FIRST USE 11-1-2011; IN COMMERCE 11-1-2011.

LINDA ESTRADA, EXAMINING ATTORNEY

CLASS 9—(Continued).

SN 85-450,020. ALASTAIR BENN, DUNKINFIELD, CHESHIRE, ENGLAND, FILED 10-18-2011.

SCREENTECH

THE MARK CONSISTS OF STANDARD CHARACTERS WITHOUT CLAIM TO ANY PARTICULAR FONT, STYLE, SIZE, OR COLOR.

FOR TELEVISIONS; TELEVISION MONITORS; TELEVISION SCREENS; ALL FOR INDOOR AND OUTDOOR INSTALLATION (U.S. CLS. 21, 23, 26, 36 AND 38).

TEJBIR SINGH, EXAMINING ATTORNEY

SN 85-450,189. GORHAM, WILLIAM E., JR., FAIRFAX, VA. FILED 10-18-2011.

STRAPCADDY

THE MARK CONSISTS OF STANDARD CHARACTERS WITHOUT CLAIM TO ANY PARTICULAR FONT, STYLE, SIZE, OR COLOR.

FOR HOLDERS FOR CELLULAR TELEPHONES, NAMELY, HOLDERS USED TO HOLD CELLULAR TELEPHONES WHEN IN MOTOR VEHICLES (U.S. CLS. 21, 23, 26, 36 AND 38).

FIRST USE 7-15-2003; IN COMMERCE 7-15-2003.
BARBARA A. GOLD, EXAMINING ATTORNEY

SN 85-450,346. CARDOZA, DEREK, LOS ANGELES, CA. FILED 10-18-2011.

10 Minutes of Touch

THE MARK CONSISTS OF STANDARD CHARACTERS WITHOUT CLAIM TO ANY PARTICULAR FONT, STYLE, SIZE, OR COLOR.

FOR DOWNLOADABLE VIDEO RECORDINGS FEATURING MESSAGE INSTRUCTION (U.S. CLS. 21, 23, 26, 36 AND 38).

JOHN WILKE, EXAMINING ATTORNEY

CLASS 9—(Continued).

SN 85-450,370. MILSTEIN, DYLAN M., DBA MONTESSORI REVOLUTION, NEWPORT COAST, CA. FILED 10-18-2011.

MONTESSORI REVOLUTION

THE MARK CONSISTS OF STANDARD CHARACTERS WITHOUT CLAIM TO ANY PARTICULAR FONT, STYLE, SIZE, OR COLOR.

NO CLAIM IS MADE TO THE EXCLUSIVE RIGHT TO USE "MONTESSORI", APART FROM THE MARK AS SHOWN.

FOR COMPUTER SOFTWARE FOR LEARNING READING, LANGUAGE, MATH, GEOGRAPHY, AND PRACTICAL LIFE SKILLS THAT MAY BE DOWNLOADED FROM A GLOBAL COMPUTER NETWORK (U.S. CLS. 21, 23, 26, 36 AND 38).

NAPOLEON SHARMA, EXAMINING ATTORNEY

SN 85-451,279. IGT, RENO, NV. FILED 10-19-2011.

TANGO DE ORO

THE MARK CONSISTS OF STANDARD CHARACTERS WITHOUT CLAIM TO ANY PARTICULAR FONT, STYLE, SIZE, OR COLOR.

THE ENGLISH TRANSLATION OF "DE ORO" IN THE MARK IS "OF GOLD".

FOR GAMING MACHINES, NAMELY, DEVICES WHICH ACCEPT A WAGER (U.S. CLS. 21, 23, 26, 36 AND 38).

AHSEN KHAN, EXAMINING ATTORNEY

SN 85-451,549. LDC INTERNATIONAL CORPORATION, NEW CASTLE COUNTY, DE. FILED 10-19-2011.

LDCSolution

THE MARK CONSISTS OF THE WORDING "LDCSOLUTION" IN STYLIZED FONT.

THE WORDING "LDCSOLUTION" HAS NO MEANING IN A FOREIGN LANGUAGE.

FOR CABLE CONNECTORS; COAXIAL CABLES; COMPUTER NETWORK ADAPTERS, SWITCHES, ROUTERS AND HUBS; DIGITAL TELEPHONE SWITCHING APPARATUS; ELECTRIC CABLES AND WIRES; ELECTRONIC AND OPTICAL COMMUNICATIONS INSTRUMENTS AND COMPONENTS, NAMELY, OPTICAL TRANSCEIVERS; FIBRE-OPTIC CABLES; INSULATED COPPER ELECTRICAL WIRE; TELEPHONE WIRES (U.S. CLS. 21, 23, 26, 36 AND 38).

MAYUR VAGHANI, EXAMINING ATTORNEY

CLASS 9—(Continued).

SN 85-452,201. INDUSTRIAL WIRE & CABLE II CORP., LAKE ZURICH, IL. FILED 10-20-2011.



NO CLAIM IS MADE TO THE EXCLUSIVE RIGHT TO USE "WIRE & CABLE" AND "WIRE", APART FROM THE MARK AS SHOWN.

THE MARK CONSISTS OF A STANDING DOG WITH WIRE HELD IN ITS MOUTH AND EXTENDING BACK TO A CABLE AND WIRE SPOOL. THIS SPOOL CONTAINS THE ACRONYM "IWC2". SIX CIRCLES AND SIX THIN LINES RADIATING FROM TWO OF THE SIX CIRCLES. A SHADOW AND A SEMI-CIRCLE DESIGN ARE LOCATED BETWEEN THE DOG'S FRONT LEGS AND FEET. THE STYLIZED LETTERS, NUMBERS, AND WORDS "IWC2 WIRE & CABLE" APPEAR ABOVE THE DOG DESIGN IN AN ARC. THE STYLIZED WORDING "WIRE D'AWG" APPEARS BELOW THE DOG DESIGN.

FOR INSULATED ELECTRICAL WIRE FOR USE AS A PERIMETER WIRE IN PET CONTAINMENT; INSULATED ELECTRICAL WIRE FOR USE AS A TRACER WIRE FOR LOCATION OF UNDERGROUND UTILITIES (U.S. CLS. 21, 23, 26, 36 AND 38).

FIRST USE 11-14-2008; IN COMMERCE 1-5-2009.
LAURIE MAYES, EXAMINING ATTORNEY

SN 85-454,556. RODALE INC., EMMAUS, PA. FILED 10-24-2011.

RUNNER'S WORLD

THE MARK CONSISTS OF STANDARD CHARACTERS WITHOUT CLAIM TO ANY PARTICULAR FONT, STYLE, SIZE, OR COLOR.

OWNER OF U.S. REG. NOS. 2,643,641, 3,984,078 AND OTHERS.

SEC. 2(F) AS TO "RUNNER'S".

FOR DOWNLOADABLE SOFTWARE IN THE NATURE OF A MOBILE APPLICATION FOR PROVIDING INFORMATION IN THE FIELDS OF HEALTH, FITNESS, DIET, EXERCISE, LIFESTYLE AND NUTRITION (U.S. CLS. 21, 23, 26, 36 AND 38).

FIRST USE 9-0-2011; IN COMMERCE 9-0-2011.

FLORENTINA BLANDU, EXAMINING ATTORNEY

CLASS 9—(Continued).

SN 85-456,294. RELIANT ENERGY RETAIL HOLDINGS, LLC, HOUSTON, TX. FILED 10-26-2011.

Reliant e-Sense App

THE MARK CONSISTS OF STANDARD CHARACTERS WITHOUT CLAIM TO ANY PARTICULAR FONT, STYLE, SIZE, OR COLOR.

OWNER OF U.S. REG. NOS. 2,747,525, 2,983,403 AND OTHERS.

NO CLAIM IS MADE TO THE EXCLUSIVE RIGHT TO USE "APP", APART FROM THE MARK AS SHOWN.

FOR DOWNLOADABLE SOFTWARE IN THE NATURE OF A MOBILE APPLICATION THAT ALLOWS CONSUMERS TO VIEW THEIR ELECTRICITY USAGE AND BILLING DATA (U.S. CLS. 21, 23, 26, 36 AND 38).

FIRST USE 6-1-2011; IN COMMERCE 6-1-2011.

WANDA KAY PRICE, EXAMINING ATTORNEY

SN 85-456,925. NATIONAL CINEMEDIA, LLC, CENTENNIAL, CO. FILED 10-26-2011.

MOVIE NIGHT OUT

THE MARK CONSISTS OF STANDARD CHARACTERS WITHOUT CLAIM TO ANY PARTICULAR FONT, STYLE, SIZE, OR COLOR.

OWNER OF U.S. REG. NO. 4,051,772.

NO CLAIM IS MADE TO THE EXCLUSIVE RIGHT TO USE "MOVIE", APART FROM THE MARK AS SHOWN.

FOR DOWNLOADABLE COMPUTER SOFTWARE APPLICATIONS ENABLING USERS TO POST, SHARE, STORE AND LINK CONTENT IN THE FIELD OF MOVIES, CELEBRITY AND ENTERTAINMENT NEWS; DOWNLOADABLE MEDIA, NAMELY, VIDEOS, AUDIO FILES, COMPUTER SOFTWARE APPLICATIONS ENABLING USERS TO POST, SHARE, STORE AND LINK CONTENT, AND WIDGETS IN THE NATURE OF SOFTWARE APPLICATIONS ENABLING USERS TO POST, SHARE, STORE AND LINK CONTENT, ALL FEATURING RICH MEDIA ENTERTAINMENT; MOBILE MEDIA CONTENT IN THE NATURE OF DOWNLOADABLE AUDIO AND VIDEO RECORDINGS FEATURING ENTERTAINMENT INFORMATION; DOWNLOADABLE MOBILE MEDIA CONTENT IN THE NATURE OF PHOTOGRAPHIC, AUDIO AND VIDEO PRESENTATIONS FEATURING DOWNLOADABLE FILM CLIPS, MOVIE TRAILERS, PHOTOGRAPHS, MUSIC AND MULTIMEDIA MATERIALS ALL IN THE FIELD OF ENTERTAINMENT (U.S. CLS. 21, 23, 26, 36 AND 38).

FIRST USE 4-13-2010; IN COMMERCE 9-7-2010.

WILLIAM VERHOSEK, EXAMINING ATTORNEY

CLASS 9—(Continued).

SN 85-457,085. FLIR SYSTEMS, INC., WILSONVILLE, OR.
FILED 10-26-2011.

SAFIRE

THE MARK CONSISTS OF STANDARD CHARACTERS WITHOUT CLAIM TO ANY PARTICULAR FONT, STYLE, SIZE, OR COLOR.

FOR ELECTROMAGNETIC SENSITIVE IMAGING SYSTEMS COMPRISED OF INFRARED CAMERAS, VISIBLE LIGHT CAMERAS, LASERS, LASER DESIGNATORS, LENSES, MOUNTING DEVICES, GIMBALS, GYROS, CIRCUIT BOARDS, PROGRAMMABLE SEMI-CONDUCTOR MICROPROCESSORS, AND OPERATING SOFTWARE; AND PARTS FOR ELECTROMAGNETIC SENSITIVE IMAGING SYSTEMS, NAMELY, INFRARED CAMERAS, VISIBLE LIGHT CAMERAS, LASERS, LASER DESIGNATORS, LENSES, MOUNTING DEVICES, GIMBALS, GYROSCOPES, GYRO STABILIZATION DEVICE, CIRCUIT BOARDS, PROGRAMMABLE SEMI-CONDUCTOR MICROPROCESSORS, AND OPERATING SOFTWARE (U.S. CLS. 21, 23, 26, 36 AND 38).

THOMAS MANOR, EXAMINING ATTORNEY

SN 85-457,805. TSB PLUS DEAL CORP, MIAMI, FL. FILED
10-27-2011.

OYE

THE MARK CONSISTS OF STANDARD CHARACTERS WITHOUT CLAIM TO ANY PARTICULAR FONT, STYLE, SIZE, OR COLOR.

THE ENGLISH TRANSLATION OF "OYE" IN THE MARK IS "LISTEN UP".

FOR CELL PHONES; GPS NAVIGATION DEVICE; PC TABLET; TABLET COMPUTER (U.S. CLS. 21, 23, 26, 36 AND 38).

MICHAEL ENGEL, EXAMINING ATTORNEY

SN 85-457,851. ADVANCE MAGAZINE PUBLISHERS INC.,
NEW YORK, NY. FILED 10-27-2011.

IDEA FLIGHT ENTERPRISE

THE MARK CONSISTS OF STANDARD CHARACTERS WITHOUT CLAIM TO ANY PARTICULAR FONT, STYLE, SIZE, OR COLOR.

NO CLAIM IS MADE TO THE EXCLUSIVE RIGHT TO USE "ENTERPRISE", APART FROM THE MARK AS SHOWN.

FOR COMPUTER SOFTWARE FOR SHARING PRESENTATIONS, DOCUMENTS AND DESIGNS (U.S. CLS. 21, 23, 26, 36 AND 38).

FIRST USE 8-23-2011; IN COMMERCE 8-23-2011.

TRACY FLETCHER, EXAMINING ATTORNEY

CLASS 9—(Continued).

SN 85-460,097. JWIN ELECTRONICS CORP., DBA ILUV
CREATIVE TECHNOLOGY, PORT WASHINGTON, NY.
FILED 10-31-2011.

MyBOT OmniFit Technology

THE MARK CONSISTS OF STANDARD CHARACTERS WITHOUT CLAIM TO ANY PARTICULAR FONT, STYLE, SIZE, OR COLOR.

OWNER OF U.S. REG. NO. 3,712,609.

NO CLAIM IS MADE TO THE EXCLUSIVE RIGHT TO USE "TECHNOLOGY", APART FROM THE MARK AS SHOWN.

FOR AUDIO AMPLIFIERS; AUDIO AND VIDEO CASSETTE RECORDERS; AUDIO AND VIDEO RECORDINGS FEATURING MUSIC AND ARTISTIC PERFORMANCES; AUDIO AND VISUAL HEADSETS FOR USE IN PLAYING VIDEO GAMES; AUDIO CABLES; AUDIO CASSETTE AND CD PLAYERS; AUDIO CASSETTE DECKS FOR AUTOMOBILES; AUDIO CASSETTE PLAYERS; AUDIO CASSETTE RECORDERS; AUDIO CIRCUIT BOARDS; AUDIO-RECEIVERS AND VIDEO-RECEIVERS; AUDIO-VIDEO RECEIVERS; BLANK CD-ROMS FOR SOUND OR VIDEO RECORDING; BLANK VIDEO CASSETTES; BLANK VIDEO TAPES; BUILDING SECURITY SYSTEMS COMPRISING SOFTWARE AND HARDWARE FOR PROVIDING PICTURE, VIDEO, ALARM STATUS, BUILDING PLANS, AND OTHER INFORMATION TO A REMOTE STATION; CAMERA STABILITY ACCESSORY, NAMELY, A SUPPORT ARM, VEST AND SLED FOR FILM AND VIDEO CAMERAS TO ABSORB SHAKING MOVES WHILE SHOOTING; CAR VIDEO RECORDERS; CHILDREN'S VIDEO TAPES; COMPONENT VIDEO CABLES; COMPUTER GAME SOFTWARE FOR GAMING MACHINES, NAMELY, SLOT MACHINES AND VIDEO LOTTERY TERMINALS; COMPUTER GAME SOFTWARE FOR PERSONAL COMPUTERS AND HOME VIDEO GAME CONSOLES; COMPUTER GAME SOFTWARE FOR USE WITH PERSONAL COMPUTERS, HOME VIDEO GAME CONSOLES USED WITH TELEVISIONS AND ARCADE-BASED VIDEO GAME CONSOLES; COMPUTER HARDWARE FOR COMMUNICATING AUDIO, VIDEO AND DATA BETWEEN COMPUTERS VIA A GLOBAL COMPUTER NETWORK, WIDE-AREA COMPUTER NETWORKS, AND PEER-TO-PEER COMPUTER NETWORKS; COMPUTER HARDWARE FOR IP VIDEO SURVEILLANCE; COMPUTER PROGRAMS FOR EDITING IMAGES, SOUND AND VIDEO; COMPUTER PROGRAMS FOR VIDEO AND COMPUTER GAMES; COMPUTER SOFTWARE AND COMPUTER HARDWARE FOR USE IN LANGUAGE LOCALIZATION, BY MEANS OF LANGUAGE TRANSLATION, SUBTITLING, DUBBING, CLOSED CAPTIONING AND TELETXT FOR FEATURE FILMS, TELEVISION PROGRAMS, VIDEOS AND DIGITAL MEDIA IN GENERAL; COMPUTER SOFTWARE AND FIRMWARE FOR GAMES OF CHANCE ON ANY COMPUTERIZED PLATFORM, INCLUDING DEDICATED GAMING CONSOLES, VIDEO BASED SLOT MACHINES, REEL BASED SLOT MACHINES, AND VIDEO LOTTERY TERMINALS; COMPUTER SOFTWARE FEATURING MUSICAL SOUND RECORDINGS AND MUSICAL VIDEO RECORDINGS; COMPUTER SOFTWARE FOR CONTROLLING THE OPERATION OF AUDIO AND VIDEO DEVICES; COMPUTER SOFTWARE FOR USE IN THE ENCRYPTION AND DECRYPTION OF DIGITAL FILES, INCLUDING AUDIO, VIDEO, TEXT, BINARY, STILL IMAGES, GRAPHICS AND MULTIMEDIA FILES; COMPUTER SOFTWARE FOR USE IN THE SAFEGUARDING OF DIGITAL FILES, INCLUDING AUDIO, VIDEO, TEXT, BINARY, STILL IMAGES, GRAPHICS AND MULTIMEDIA FILES; COMPUTER SOFTWARE, NAMELY, GAME ENGINE SOFTWARE FOR VIDEO GAME DEVELOPMENT AND OPERATION; COMPUTERIZED VIDEO GAME TABLES FOR GAMING PURPOSES, NAMELY, A COMPUTER-

CLASS 9—(Continued).

IZED VIDEO CRAPS GAME TABLE; COMPUTERIZED VIDEO TABLE GAMES FOR GAMING PURPOSES; CONSUMER ELECTRONIC PRODUCTS, NAMELY, AUDIO AMPLIFIERS, AUDIO SPEAKERS, AUDIO RECEIVERS, ELECTRICAL AUDIO AND SPEAKER CABLES AND CONNECTORS, AUDIO DECODERS, VIDEO DECODERS, SPEAKERS, POWER CONVERSION DEVICES, POWER CONVERTERS, AND POWER INVERTERS; CONTINGENCY RESPONSE COMMUNICATION SYSTEM DESIGNED TO PROVIDE RADIO INTEROPERABILITY, STREAMING VIDEO, WIRELESS INTERNET, AND VOIP PHONE; MANIPULATORS FOR THE REMOTE OPERATION OF ROBOTIC ARMS; ROBOTS FOR PERSONAL OR HOBBY USE; ROBOTS FOR PERSONAL, EDUCATIONAL AND HOBBY USE AND STRUCTURAL PARTS THEREFOR (U.S. CLS. 21, 23, 26, 36 AND 38).

IRA J. GOODSaid, EXAMINING ATTORNEY

SN 85-460,120. JWIN ELECTRONICS CORP., DBA ILUV CREATIVE TECHNOLOGY, PORT WASHINGTON, NY. FILED 10-31-2011.

Mobi-Dock

THE MARK CONSISTS OF STANDARD CHARACTERS WITHOUT CLAIM TO ANY PARTICULAR FONT, STYLE, SIZE, OR COLOR.

FOR AUDIO AMPLIFIERS; AUDIO AND VIDEO CASSETTE RECORDERS; AUDIO AND VIDEO RECORDINGS FEATURING MUSIC AND ARTISTIC PERFORMANCES; AUDIO AND VISUAL HEADSETS FOR USE IN PLAYING VIDEO GAMES; AUDIO CABLES; AUDIO CASSETTE AND CD PLAYERS; AUDIO CASSETTE DECKS FOR AUTOMOBILES; AUDIO CASSETTE PLAYERS; AUDIO CASSETTE RECORDERS; AUDIO CIRCUIT BOARDS; AUDIO ELECTRONIC COMPONENTS, NAMELY, SURROUND SOUND SYSTEMS; AUDIO EQUIPMENT FOR VEHICLES, NAMELY, LOUD SPEAKERS FOR AUTOMOTIVE AUDIO SYSTEMS; AUDIO EQUIPMENT FOR VEHICLES, NAMELY, STEREOs, SPEAKERS, AMPLIFIERS, EQUALIZERS, CROSSOVERS AND SPEAKER HOUSINGS; AUDIO EQUIPMENT FOR VEHICLES, NAMELY, SUBWOOFERS; AUDIO HEADPHONES; AUDIO MIXERS; AUDIO PROCESSING EQUIPMENT, NAMELY, LIMITERS AND COMPRESSORS; AUDIO RECORDERS; AUDIO SPEAKER ENCLOSURES; AUDIO SPEAKERS; AUDIO TAPE RECORDERS; AUDIO TAPES FEATURING MUSIC; AUDIO-FREQUENCY TRANSFORMERS; AUDIO-RECEIVERS AND VIDEO-RECEIVERS; AUDIO-VIDEO RECEIVERS; BLANK AUDIO CASSETTES; BLANK AUDIO TAPES; BLANK DIGITAL AUDIO TAPES; BOXES SPECIALLY ADAPTED FOR HOUSING AUDIO EQUIPMENT; CASES FOR MUSIC, AUDIO AND RELATED ELECTRONIC EQUIPMENT, NAMELY, CASES FOR AUDIO TUNERS, AUDIO RECEIVERS, AMPLIFIERS, TAPE PLAYERS, COMPACT DISC PLAYERS, MP3 CONTROLLERS/PLAYERS, AUDIO MIXERS, AUDIO SPEAKERS IN THE NATURE OF MUSIC STUDIO MONITORS, MICROPHONES, AUDIO SPEAKERS, COMPACT DISCS, AUDIO TAPES, PORTABLE COMPUTERS, ANTENNAS, PHONOGRAPHIC RECORD PLAYERS, AUDIO RECORDING EQUIPMENT, AND THE CABLES ASSOCIATED WITH ALL OF THE FOREGOING EQUIPMENT; CLEANING DISCS FOR CLEANING THE LENS OF OPTICAL DISC DRIVES USED IN COMPUTERS AND DIGITAL VIDEO RECORDERS; COMBINATION VIDEO PLAYERS AND RECORDERS; COMPUTER DOCKING STATION; COMPUTER HARDWARE AND COMPUTER SOFTWARE PROGRAMS FOR THE INTEGRATION OF TEXT, AUDIO, GRAPHICS, STILL IMAGES AND MOVING PICTURES INTO AN INTERACTIVE DELIVERY FOR MULTIMEDIA APPLICATIONS; COMPUTER HARDWARE FOR COMMUNICATING AUDIO, VIDEO AND DATA BE-

CLASS 9—(Continued).

TWEEN COMPUTERS VIA A GLOBAL COMPUTER NETWORK, WIDE-AREA COMPUTER NETWORKS, AND PEER-TO-PEER COMPUTER NETWORKS; COMPUTER SOFTWARE FOR CONTROLLING THE OPERATION OF AUDIO AND VIDEO DEVICES; COMPUTER SOFTWARE FOR MANIPULATING DIGITAL AUDIO INFORMATION FOR USE IN AUDIO MEDIA APPLICATIONS; COMPUTER SOFTWARE FOR USE IN THE ENCRYPTION AND DECRYPTION OF DIGITAL FILES, INCLUDING AUDIO, VIDEO, TEXT, BINARY, STILL IMAGES, GRAPHICS AND MULTIMEDIA FILES; COMPUTER SOFTWARE FOR USE IN THE SAFEGUARDING OF DIGITAL FILES, INCLUDING AUDIO, VIDEO, TEXT, BINARY, STILL IMAGES, GRAPHICS AND MULTIMEDIA FILES; COMPUTER SOFTWARE TO CONTROL AND IMPROVE COMPUTER AND AUDIO EQUIPMENT SOUND QUALITY; COMPUTER SOFTWARE TO ENHANCE THE AUDIO-VISUAL CAPABILITIES OF MULTIMEDIA APPLICATIONS, NAMELY, FOR THE INTEGRATION OF TEXT, AUDIO, GRAPHICS, STILL IMAGES AND MOVING PICTURES; CONICAL ATTACHMENT TO AN AUDIO SPEAKER FOR DIFFUSING AND DISTRIBUTING SOUND AS IT IS TRANSMITTED FROM THE SPEAKER; CONSUMER ELECTRONIC PRODUCTS, NAMELY, AUDIO AMPLIFIERS, AUDIO SPEAKERS, AUDIO RECEIVERS, ELECTRICAL AUDIO AND SPEAKER CABLES AND CONNECTORS, AUDIO DECODERS, VIDEO DECODERS, SPEAKERS, POWER CONVERSION DEVICES, POWER CONVERTERS, AND POWER INVERTERS; DIGITAL AUDIO AND VIDEO RECORDERS AND PLAYERS; DIGITAL AUDIO PLAYERS; DIGITAL AUDIO TAPE PLAYERS; DIGITAL AUDIO TAPE RECORDERS; ELECTRONIC DOCKING STATIONS (U.S. CLS. 21, 23, 26, 36 AND 38).

IRA J. GOODSaid, EXAMINING ATTORNEY

SN 85-460,268. JWIN ELECTRONICS CORP., DBA ILUV CREATIVE TECHNOLOGY, PORT WASHINGTON, NY. FILED 10-31-2011.

Mobi-Air

THE MARK CONSISTS OF STANDARD CHARACTERS WITHOUT CLAIM TO ANY PARTICULAR FONT, STYLE, SIZE, OR COLOR.

FOR AUDIO AMPLIFIERS; AUDIO AND VIDEO CASSETTE RECORDERS; AUDIO AND VIDEO RECORDINGS ABOUT TENNIS; AUDIO AND VIDEO RECORDINGS FEATURING MUSIC AND ARTISTIC PERFORMANCES; AUDIO AND VISUAL HEADSETS FOR USE IN PLAYING VIDEO GAMES; AUDIO CABLES; AUDIO CASSETTE AND CD PLAYERS; AUDIO CASSETTE DECKS FOR AUTOMOBILES; AUDIO CASSETTE PLAYERS; AUDIO CASSETTE RECORDERS; AUDIO CIRCUIT BOARDS; AUDIO ELECTRONIC COMPONENTS, NAMELY, SURROUND SOUND SYSTEMS; AUDIO EQUIPMENT FOR VEHICLES, NAMELY, LOUD SPEAKERS FOR AUTOMOTIVE AUDIO SYSTEMS; AUDIO EQUIPMENT FOR VEHICLES, NAMELY, STEREOs, SPEAKERS, AMPLIFIERS, EQUALIZERS, CROSSOVERS AND SPEAKER HOUSINGS; AUDIO EQUIPMENT FOR VEHICLES, NAMELY, SUBWOOFERS; AUDIO HEADPHONES; AUDIO MIXERS; AUDIO PROCESSING EQUIPMENT, NAMELY, LIMITERS AND COMPRESSORS; AUDIO RECORDERS; AUDIO SPEAKER ENCLOSURES; AUDIO SPEAKERS; AUDIO SPEAKERS THAT MAY BE ATTACHED WITH ADHESIVE TO THE ABDOMINAL AREA OF PREGNANT WOMEN FOR THE PURPOSE OF TRANSMITTING MUSIC/SOUNDS TO THE FETUS, NOT FOR MEDICAL PURPOSES; AUDIO TAPE RECORDERS; AUDIO TAPES FEATURING MUSIC; AUDIO-FREQUENCY TRANSFORMERS; AUDIO-RECEIVERS AND VIDEO-RECEIVERS; AUDIO-VIDEO RECEIVERS; BLANK AUDIO CASSETTES;

CLASS 9—(Continued).

BLANK DIGITAL AUDIO TAPES; BOXES SPECIALLY ADAPTED FOR HOUSING AUDIO EQUIPMENT; CASES FOR MUSIC, AUDIO AND RELATED ELECTRONIC EQUIPMENT, NAMELY, CASES FOR AUDIO TUNERS, AUDIO RECEIVERS, AMPLIFIERS, TAPE PLAYERS, COMPACT DISC PLAYERS, MP3 CONTROLLERS/PLAYERS, AUDIO MIXERS, AUDIO SPEAKERS IN THE NATURE OF MUSIC STUDIO MONITORS, MICROPHONES, AUDIO SPEAKERS, COMPACT DISCS, AUDIO TAPES, PORTABLE COMPUTERS, ANTENNAS, PHONOGRAPHIC RECORD PLAYERS, AUDIO RECORDING EQUIPMENT, AND THE CABLES ASSOCIATED WITH ALL OF THE FOREGOING EQUIPMENT; COMPUTER DOCKING STATION; COMPUTER HARDWARE AND COMPUTER SOFTWARE PROGRAMS FOR THE INTEGRATION OF TEXT, AUDIO, GRAPHICS, STILL IMAGES AND MOVING PICTURES INTO AN INTERACTIVE DELIVERY FOR MULTIMEDIA APPLICATIONS; COMPUTER HARDWARE FOR COMMUNICATING AUDIO, VIDEO AND DATA BETWEEN COMPUTERS VIA A GLOBAL COMPUTER NETWORK, WIDE-AREA COMPUTER NETWORKS, AND PEER-TO-PEER COMPUTER NETWORKS; COMPUTER SOFTWARE FOR CONTROLLING THE OPERATION OF AUDIO AND VIDEO DEVICES; COMPUTER SOFTWARE FOR MANIPULATING DIGITAL AUDIO INFORMATION FOR USE IN AUDIO MEDIA APPLICATIONS; COMPUTER SOFTWARE FOR USE IN THE ENCRYPTION AND DECRYPTION OF DIGITAL FILES, INCLUDING AUDIO, VIDEO, TEXT, BINARY, STILL IMAGES, GRAPHICS AND MULTIMEDIA FILES; COMPUTER SOFTWARE FOR USE IN THE SAFEGUARDING OF DIGITAL FILES, INCLUDING AUDIO, VIDEO, TEXT, BINARY, STILL IMAGES, GRAPHICS AND MULTIMEDIA FILES; COMPUTER SOFTWARE TO CONTROL AND IMPROVE COMPUTER AND AUDIO EQUIPMENT SOUND QUALITY; COMPUTER SOFTWARE TO ENHANCE THE AUDIO-VISUAL CAPABILITIES OF MULTIMEDIA APPLICATIONS, NAMELY, FOR THE INTEGRATION OF TEXT, AUDIO, GRAPHICS, STILL IMAGES AND MOVING PICTURES; CONICAL ATTACHMENT TO AN AUDIO SPEAKER FOR DIFFUSING AND DISTRIBUTING SOUND AS IT IS TRANSMITTED FROM THE SPEAKER; CONSUMER ELECTRONIC PRODUCTS, NAMELY, AUDIO AMPLIFIERS, AUDIO SPEAKERS, AUDIO RECEIVERS, ELECTRICAL AUDIO AND SPEAKER CABLES AND CONNECTORS, AUDIO DECODERS, VIDEO DECODERS, SPEAKERS, POWER CONVERSION DEVICES, POWER CONVERTERS, AND POWER INVERTERS; DIGITAL AUDIO AND VIDEO RECORDERS AND PLAYERS; DIGITAL AUDIO TAPE RECORDERS; DISTRIBUTION AMPLIFIERS FOR AUDIO AND VIDEO SIGNALS; DOWNLOADABLE AUDIO FILES, MULTIMEDIA FILES, TEXT FILES, E-MAILS, WRITTEN DOCUMENTS, AUDIO MATERIAL, VIDEO MATERIAL AND GAMES FEATURING INFORMATION IN THE FORM OF DOWNLOADABLE SHORT EDUCATIONAL/TRAINING COMMUNICATIONS IN THE FIELD OF HUMAN RESOURCE DEVELOPMENT FOR THE PROMOTION OF EMPLOYEE RETENTION, CAREER GROWTH AND INCREASED PRODUCTIVITY FOR EMPLOYEES AND EMPLOYERS; DOWNLOADABLE IMAGE FILE CONTAINING ARTWORK, TEXT, AUDIO, VIDEO, GAMES AND INTERNET WEB LINKS RELATING TO SPORTING AND CULTURAL ACTIVITIES; ELECTRIC AUDIO PLAYBACK UNITS; ELECTRIC AUDIO PLAYBACK UNITS WITH LIGHTS AND SPEAKERS; ELECTRONIC DOCKING STATIONS; ELECTRONIC EQUIPMENT, NAMELY, TRANSFORMERS, BALUNS, CABLES USED IN CONNECTION WITH COMPUTERS, COMPUTER PERIPHERAL DEVICES, TELEVISIONS, AUDIO-VIDEO EQUIPMENT, CLOSED-CIRCUIT TV EQUIPMENT AND TELECOMMUNICATION EQUIPMENT; ELECTRONIC INTERCONNECTERS FOR AUDIO AND VIDEO SIGNALS; ELECTRONIC PRODUCTS FOR THE GENERATION, MEASUREMENT, AND ANALYSIS OF AUDIO SIGNALS, NAMELY, AUDIO ANALYZERS; ELECTRONIC PRODUCTS FOR THE MANIPULATION OF THE FREQUENCY, TIME, AND AMPLITUDE CHARACTERISTICS OF AUDIO SIGNALS, NAMELY, AUDIO PROCESSORS; ELECTRONIC SCALERS FOR AUDIO AND VIDEO SIGNALS; ELECTRONIC SWITCHERS FOR AUDIO AND VIDEO SIGNALS; EMERGENCY NOTIFICATION SYSTEM COMPRISED OF A DATA PROCESSOR AND A USER INPUT DEVICE FOR CONNECTING THE DATA PRO-

CLASS 9—(Continued).

CESSOR TO AN EMERGENCY RESPONSE ENTITY THROUGH A COMMUNICATION NETWORK AND ALLOWING AUDIO AND DATA COMMUNICATION BETWEEN THE PROCESSOR AND THE ENTITY; INTERACTIVE MULTIMEDIA SOFTWARE FEATURING AUDIO AND VIDEO INFORMATION FOR DENTISTS ON THE SUBJECT OF TREATMENTS, PROCEDURES AND ALTERNATIVES RELATED TO DENTISTRY; INTERACTIVE MULTIMEDIA SOFTWARE FEATURING AUDIO AND VIDEO INFORMATION FOR PATIENTS ON THE SUBJECT OF TREATMENTS, PROCEDURES AND ALTERNATIVES RELATED TO DENTISTRY; INTERACTIVE, MOTION SENSITIVE ELECTRONIC ANNOUNCER FOR RECORDING AND PLAYBACK OF AN AUDIO MESSAGE OR INSTRUCTION; MATRIX SWITCHERS FOR AUDIO AND VIDEO SIGNALS; NON-FICTION AUDIO BOOKS ON A VARIETY OF TOPICS; PORTABLE AND HANDHELD DIGITAL ELECTRONIC DEVICES FOR RECORDING, ORGANIZING, TRANSMITTING, MANIPULATING, AND REVIEWING TEXT, DATA, IMAGE, AND AUDIO FILES; PRERECORDED AUDIO TAPES FEATURING MUSIC; SOFTWARE TO CONTROL AND IMPROVE AUDIO EQUIPMENT SOUND QUALITY; STANDS SPECIALLY ADAPTED FOR STEREOS AND AUDIO SPEAKERS; TRANSMITTERS AND RECEIVERS FOR AUDIO AND VIDEO SIGNALS FOR TRANSMISSION OVER TWISTED PAIR CABLES; VIDEO CASSETTE RECORDERS AND PLAYERS, COMPACT DISC PLAYERS, DIGITAL AUDIO TAPE RECORDERS AND PLAYERS, ELECTRONIC DIARIES (U.S. CLS. 21, 23, 26, 36 AND 38).

IRA J. GOODSaid, EXAMINING ATTORNEY

SN 85-461,326. YES GROUP, INC., NEW YORK, NY. FILED 11-1-2011.



THE MARK CONSISTS OF A STYLIZED BIRD DESIGN SURROUNDED BY THE OUTLINE OF A SHIELD.

FOR SPECTACLES, EYEGLASSES, EYEGGLASS CASES, SUNGLASSES, SUNGLASS CASES, SPORTS GOGGLES, SKI GOGGLES, MOTORCYCLE GOGGLES AND OPTICAL FRAMES (U.S. CLS. 21, 23, 26, 36 AND 38).

MICHAEL WEBSTER, EXAMINING ATTORNEY

CLASS 9—(Continued).

SN 85-461,615. YES GROUP, INC., NEW YORK, NY. FILED 11-1-2011.



THE MARK CONSISTS OF THE WORD "SALAMANDER" CENTERED BELOW A SILHOUETTED IMAGE OF A SALAMANDER.
 FOR SPECTACLES, EYEGLASSES, EYEGLASS CASES, SUNGLASSES, SUNGLASS CASES, SPORTS GOGGLES, SKI GOGGLES, MOTORCYCLE GOGGLES AND OPTICAL FRAMES (U.S. CLS. 21, 23, 26, 36 AND 38).
 MICHAEL WEBSTER, EXAMINING ATTORNEY

SN 85-461,753. YES GROUP, INC., NEW YORK, NY. FILED 11-1-2011.



THE MARK CONSISTS OF THE WORD "CHIMERO" ABOVE A TWO HEADED BEAST CONSISTING OF A HEAD AND BODY OF A LION, AND A SECOND HEAD WITH A HORN, AND A TAIL IN THE FORM OF A SERPENT, ALL SURROUNDED BY THE OUTLINE OF A SHIELD.
 FOR SPECTACLES, EYEGLASSES, EYEGLASS CASES, SUNGLASSES, SUNGLASS CASES, SPORTS GOGGLES, SKI GOGGLES, MOTORCYCLE GOGGLES AND OPTICAL FRAMES (U.S. CLS. 21, 23, 26, 36 AND 38).
 MICHAEL WEBSTER, EXAMINING ATTORNEY

CLASS 9—(Continued).

SN 85-462,584. SMULE, INC., PALO ALTO, CA. FILED 11-2-2011.



THE MARK CONSISTS OF STANDARD CHARACTERS WITHOUT CLAIM TO ANY PARTICULAR FONT, STYLE, SIZE, OR COLOR.
 FOR GAME SOFTWARE; DOWNLOADABLE COMPUTER SOFTWARE FOR MOBILE DEVICES FOR PERSONALIZING VIDEO PERFORMANCES ON A MOBILE DEVICE BASED ON USER INTERACTION; COMPUTER APPLICATION SOFTWARE FOR MOBILE COMPUTERS, NAMELY, SOFTWARE THAT ALLOWS A MOBILE DEVICE TO BE USED AS A MUSICAL INSTRUMENT AND ALLOWS USERS TO PLAY MUSIC ALONE OR VIRTUALLY WITH OTHERS; COMPUTER SOFTWARE PROGRAMS FOR THE INTEGRATION OF TEXT, AUDIO, GRAPHICS, STILL IMAGES AND MOVING PICTURES INTO AN INTERACTIVE DELIVERY FOR MULTIMEDIA APPLICATIONS; SOFTWARE FOR PROCESSING DIGITAL MUSIC FILES; COMPUTER SOFTWARE FEATURING MUSICAL SOUND RECORDINGS AND MUSICAL VIDEO RECORDINGS; COMPUTER SOFTWARE FOR COMMUNICATING WITH USERS OF HAND-HELD COMPUTERS; COMPUTER SOFTWARE FOR MANIPULATING DIGITAL AUDIO INFORMATION FOR USE IN AUDIO MEDIA APPLICATIONS; COMPUTER SOFTWARE FOR PROCESSING DIGITAL MUSIC FILES; COMPUTER SOFTWARE PLATFORMS FOR DEVELOPMENT OF INTERACTIVE AUDIO APPLICATIONS FOR USE WITH MOBILE AUDIO PLATFORMS; COMPUTER SOFTWARE EXECUTABLE TO CAUSE MOBILE DEVICES TO FUNCTION AS MUSICAL INSTRUMENTS; DOWNLOADABLE COMPUTER SOFTWARE FOR MOBILE DEVICES THAT ENABLES USERS TO TRANSFORM AND ENHANCE THE VIDEO AND AUDIO CAPABILITIES OF THEIR MOBILE DEVICES; DOWNLOADABLE COMPUTER SOFTWARE EXECUTABLE TO COMMUNICATE AMONGST MOBILE DEVICES USING AUDIO ENCODINGS OF INFORMATION; DOWNLOADABLE COMPUTER SOFTWARE EXECUTABLE TO PROVIDE MOBILE DEVICES WITH SIGNAL PROCESSING CAPABILITIES; DOWNLOADABLE COMPUTER SOFTWARE FOR MOBILE DEVICES THAT ENABLES USERS TO INTERACTIVELY PERFORM INDIVIDUALIZED AUDIO AND VIDEO APPLICATIONS; DOWNLOADABLE COMPUTER SOFTWARE FOR MOBILE DEVICES THAT ENABLES USERS TO SEND MUSIC, TEXT, AUDIO, VIDEO, AND GRAPHICS INFORMATION TO OTHER USERS OF MOBILE DEVICES; DOWNLOADABLE COMPUTER SOFTWARE FOR MOBILE DEVICES FOR ENABLING USERS TO DOWNLOAD AND SHARE INTERACTIVE AUDIO AND MUSIC RECORDINGS (U.S. CLS. 21, 23, 26, 36 AND 38).
 FIRST USE 9-8-2011; IN COMMERCE 9-8-2011.
 AMY C. KEAN, EXAMINING ATTORNEY

CLASS 9—(Continued).

SN 85-462,860. GYRODATA INCORPORATED, HOUSTON, TX. FILED 11-2-2011.

GWD40

THE MARK CONSISTS OF STANDARD CHARACTERS WITHOUT CLAIM TO ANY PARTICULAR FONT, STYLE, SIZE, OR COLOR.

OWNER OF U.S. REG. NO. 3,993,516.
FOR DIRECTIONAL DRILLING CONTROL TOOL INCORPORATING A GYROSCOPE WHEREIN THE TOOL CONTROLS THE DIRECTION OF OIL AND GAS WELL DRILLING PROCESS; GYROSCOPIC WELLBORE MEASUREMENT TOOL, NAMELY, GYROSCOPE TOOL FOR MEASURING DIRECTION AND ORIENTATION OF A WELLBORE FOR THE OIL AND GAS, ENERGY, MINING, ENVIRONMENTAL AND CONSTRUCTION INDUSTRIES; DOWN HOLE GYROSCOPIC MEASUREMENT TOOL FOR OBTAINING DIRECTIONAL DRILLING CONTROL DATA FOR USE BY OTHERS FOR CONTROLLING THE DIRECTION OF WELLBORE DRILLING IN THE OIL AND GAS, ENERGY, MINING, ENVIRONMENTAL AND CONSTRUCTION INDUSTRIES; DIRECTIONAL DRILLING DATA COLLECTION AND ANALYSIS SOFTWARE FOR THE OIL AND GAS, ENERGY, MINING, ENVIRONMENTAL AND CONSTRUCTION INDUSTRIES; SOFTWARE FOR USE IN CONTROLLING THE DIRECTION OF WELLBORE DRILLING, NAMELY, SOFTWARE FOR COLLECTING AND ANALYZING WELLBORE DEPTH, ORIENTATION, AND DRILLING DIRECTION DATA FOR USE IN CONTROLLING DIRECTIONAL DRILLING OF A WELLBORE; AND ELECTRONIC WELLBORE DATA COLLECTOR, NAMELY, AN ELECTRONIC DEVICE FOR COLLECTION OF WELLBORE DIRECTION AND ORIENTATION DATA FROM WELLBORE MEASUREMENT DEVICES OF OTHERS IN THE OIL AND GAS, ENERGY, MINING, ENVIRONMENTAL AND CONSTRUCTION INDUSTRIES (U.S. CLS. 21, 23, 26, 36 AND 38).

RUSS HERMAN, EXAMINING ATTORNEY

SN 85-463,449. GANNETT SATELLITE INFORMATION NETWORK, INC., MCLEAN, VA. FILED 11-3-2011.

CAPTIVATE CONCIERGE

THE MARK CONSISTS OF STANDARD CHARACTERS WITHOUT CLAIM TO ANY PARTICULAR FONT, STYLE, SIZE, OR COLOR.

FOR COMPUTER SOFTWARE, NAMELY, SCHEDULING APPLICATION SOFTWARE FOR USE IN CREATING AND MANIPULATING MESSAGE CONTENT ON DISPLAY MONITORS (U.S. CLS. 21, 23, 26, 36 AND 38).
ANDREW LEASER, EXAMINING ATTORNEY

CLASS 9—(Continued).

SN 85-464,114. TELESTREAM, INC., NEVADA CITY, CA. FILED 11-3-2011.

VISTORY

THE MARK CONSISTS OF STANDARD CHARACTERS WITHOUT CLAIM TO ANY PARTICULAR FONT, STYLE, SIZE, OR COLOR.

FOR SOFTWARE THAT TRACKS VIDEOS THAT ARE BROWSED OR PLAYED ON ANY DEVICE (U.S. CLS. 21, 23, 26, 36 AND 38).

RAÚL CORDOVA, EXAMINING ATTORNEY

SN 85-464,302. EMTEQ, INC., NEW BERLIN, WI. FILED 11-4-2011.

EQUATION

THE MARK CONSISTS OF STANDARD CHARACTERS WITHOUT CLAIM TO ANY PARTICULAR FONT, STYLE, SIZE, OR COLOR.

FOR AIRCRAFT CABIN POWER SYSTEM, CONSISTING OF ELECTRICAL OUTLETS, FREQUENCY CONVERTERS, AND INVERTERS; AIRPLANE CABIN MANAGEMENT SYSTEM, NAMELY, SOFTWARE AND HARDWARE USED TO PROVIDE ACCESS TO THE INTERNET, PROVIDE IN-FLIGHT ENTERTAINMENT, CONTROL CABIN ENVIRONMENT, AND PROVIDE ACCESS TO APPLICATIONS AND SERVICES THROUGH A WEB OPERATING SYSTEM OR PORTAL INTERFACE (U.S. CLS. 21, 23, 26, 36 AND 38).

DANIEL CAPSHAW, EXAMINING ATTORNEY

CLASS 9—(Continued).

SN 85-464,514. FISSION LLC, NEW YORK, NY. FILED 11-4-2011.

NOOK TABLET

THE MARK CONSISTS OF STANDARD CHARACTERS WITHOUT CLAIM TO ANY PARTICULAR FONT, STYLE, SIZE, OR COLOR.

OWNER OF U.S. REG. NOS. 4,013,524 AND 4,023,198.

NO CLAIM IS MADE TO THE EXCLUSIVE RIGHT TO USE "TABLET", APART FROM THE MARK AS SHOWN.

FOR PORTABLE ELECTRONIC APPARATUS FOR READING, DISPLAYING, RECEIVING, PURCHASING, SHARING, LENDING, ACCESSING AND STORING DOWNLOADABLE ELECTRONIC PUBLICATIONS, NAMELY, BOOKS, E-BOOKS, MAGAZINES, NEWSPAPERS, TEXT, IMAGES, DIGITAL WEB SITE CONTENT AND DIGITAL MEDIA FEATURING MUSIC THROUGH WIRED AND WIRELESS INTERNET ACCESS, ACCESSORIES THEREFOR AND INSTRUCTIONAL MANUALS, SOLD AS A UNIT; COMPUTER SOFTWARE FOR DISPLAYING, RECEIVING, READING, PURCHASING AND ACCESSING DOWNLOADABLE ELECTRONIC PUBLICATIONS, SYNCING ELECTRONIC PUBLICATIONS WITH PORTABLE ELECTRONIC APPARATUS, LOANING AND SHARING ELECTRONIC PUBLICATIONS WITH THIRD PARTIES AND SAMPLING ELECTRONIC PUBLICATIONS; DOWNLOADABLE COMPUTER SOFTWARE FOR DISPLAYING, RECEIVING AND READING DOWNLOADABLE ELECTRONIC PUBLICATIONS AND SYNCING ELECTRONIC PUBLICATIONS WITH PORTABLE ELECTRONIC APPARATUS, LOANING AND SHARING ELECTRONIC PUBLICATIONS WITH THIRD PARTIES AND SAMPLING ELECTRONIC PUBLICATIONS; COMPUTER SOFTWARE FOR USE IN READING, DISPLAYING, PURCHASING, SHARING, LENDING AND ACCESSING ELECTRONIC PUBLICATIONS AND DIGITAL MEDIA FEATURING BOOKS, NEWSPAPERS, MAGAZINES, PERIODICALS, DIGITAL IMAGES, WEB SITES, MUSIC, GAMES AND OTHER DIGITAL ENTERTAINMENT, AND INSTRUCTIONAL MANUALS, SOLD AS A UNIT; DOWNLOADABLE COMPUTER SOFTWARE FOR USE IN READING, DISPLAYING, PURCHASING, SHARING, LENDING AND ACCESSING ELECTRONIC PUBLICATIONS AND DIGITAL MEDIA FEATURING BOOKS, NEWSPAPERS, MAGAZINES, DIGITAL IMAGES, WEB SITES, MUSIC, GAMES AND OTHER DIGITAL ENTERTAINMENT, AND INSTRUCTIONAL MANUALS, SOLD AS A UNIT; DOWNLOADABLE ELECTRONIC PUBLICATIONS IN THE NATURE OF FICTION AND NON-FICTION BOOKS, MAGAZINES, NEWSPAPERS, JOURNALS, PERIODICALS, MANUALS AND GUIDEBOOKS ON A VARIETY OF TOPICS; AUDIO BOOKS IN THE NATURE OF FICTION AND NON-FICTION WORKS ON A VARIETY OF TOPICS; DOWNLOADABLE MP3 FILES, MP3 RECORDINGS, ON-LINE DISCUSSION BOARDS, WEBCASTS, WEBINARS AND PODCASTS FEATURING MUSIC, AUDIO BOOKS ON A VARIETY OF TOPICS AND NEWS BROADCASTS (U.S. CLS. 21, 23, 26, 36 AND 38).

EMILY CARLSEN, EXAMINING ATTORNEY

CLASS 9—(Continued).

SN 85-464,725. SHANE HEDRICK, RALEIGH, NC. FILED 11-4-2011.

PHONE LASSO

THE MARK CONSISTS OF STANDARD CHARACTERS WITHOUT CLAIM TO ANY PARTICULAR FONT, STYLE, SIZE, OR COLOR.

NO CLAIM IS MADE TO THE EXCLUSIVE RIGHT TO USE "PHONE", APART FROM THE MARK AS SHOWN.

FOR TELEPHONE NECK CORD (U.S. CLS. 21, 23, 26, 36 AND 38).

ADA HAN, EXAMINING ATTORNEY

SN 85-467,309. HUAWEI TECHNOLOGIES CO., LTD., SHENZHEN, CHINA, FILED 11-8-2011.

AtomCell

THE MARK CONSISTS OF STANDARD CHARACTERS WITHOUT CLAIM TO ANY PARTICULAR FONT, STYLE, SIZE, OR COLOR.

FOR TELECOMMUNICATIONS BASE STATIONS (U.S. CLS. 21, 23, 26, 36 AND 38).

RONALD DELGIZZI, EXAMINING ATTORNEY

CLASS 9—(Continued).

SN 85-467,881. GYRODATA INCORPORATED, HOUSTON, TX. FILED 11-9-2011.

X4

THE MARK CONSISTS OF STANDARD CHARACTERS WITHOUT CLAIM TO ANY PARTICULAR FONT, STYLE, SIZE, OR COLOR.

FOR DIRECTIONAL DRILLING CONTROL TOOL INCORPORATING A GYROSCOPE WHEREIN THE TOOL CONTROLS THE DIRECTION OF OIL AND GAS WELL DRILLING PROCESS; GYROSCOPIC WELLBORE MEASUREMENT TOOL, NAMELY GYROSCOPE TOOL FOR MEASURING DIRECTION AND ORIENTATION OF A WELLBORE FOR THE OIL AND GAS, ENERGY, MINING, ENVIRONMENTAL AND CONSTRUCTION INDUSTRIES; DOWN HOLE GYROSCOPIC MEASUREMENT TOOL FOR OBTAINING DIRECTIONAL DRILLING CONTROL DATA FOR USE BY OTHERS FOR CONTROLLING THE DIRECTION OF WELLBORE DRILLING IN THE OIL AND GAS, ENERGY, MINING, ENVIRONMENTAL AND CONSTRUCTION INDUSTRIES; DIRECTIONAL DRILLING DATA COLLECTION AND ANALYSIS SOFTWARE FOR THE OIL AND GAS, ENERGY, MINING, ENVIRONMENTAL AND CONSTRUCTION INDUSTRIES; SOFTWARE FOR USE IN CONTROLLING THE DIRECTION OF WELLBORE DRILLING, NAMELY SOFTWARE FOR COLLECTING AND ANALYZING WELLBORE DEPTH, ORIENTATION, AND DRILLING DIRECTION DATA FOR USE IN CONTROLLING DIRECTIONAL DRILLING OF A WELLBORE; AND ELECTRONIC WELLBORE DATA COLLECTOR, NAMELY, AN ELECTRONIC DEVICE FOR COLLECTION OF WELLBORE DIRECTION AND ORIENTATION DATA FROM WELLBORE MEASUREMENT DEVICES OF OTHERS IN THE OIL AND GAS, ENERGY, MINING, ENVIRONMENTAL AND CONSTRUCTION INDUSTRIES (U.S. CLS. 21, 23, 26, 36 AND 38).

RUSS HERMAN, EXAMINING ATTORNEY

SN 85-467,915. PERSONAL DEVELOPMENT SUPPORT GROUP LLC, KENNETT SQUARE, PA. FILED 11-9-2011.

Little Pocket Guru

THE MARK CONSISTS OF STANDARD CHARACTERS WITHOUT CLAIM TO ANY PARTICULAR FONT, STYLE, SIZE, OR COLOR.

FOR COMPUTER APPLICATION SOFTWARE FOR MOBILE PHONES, NAMELY, SOFTWARE OFFERING AUTOMATIC REMINDERS, INSTRUCTION, REFERENCE, AND CUSTOMIZED GUIDANCE BASED UPON INDIVIDUALIZED PROGRAM OF HEALTH AND WELLNESS (U.S. CLS. 21, 23, 26, 36 AND 38).

THOMAS MANOR, EXAMINING ATTORNEY

CLASS 9—(Continued).

SN 85-468,136. GYRODATA INCORPORATED, HOUSTON, TX. FILED 11-9-2011.

GWD70

THE MARK CONSISTS OF STANDARD CHARACTERS WITHOUT CLAIM TO ANY PARTICULAR FONT, STYLE, SIZE, OR COLOR.

OWNER OF U.S. REG. NO. 3,993,516.
 FOR DIRECTIONAL DRILLING CONTROL TOOL INCORPORATING A GYROSCOPE WHEREIN THE TOOL CONTROLS THE DIRECTION OF OIL AND GAS WELL DRILLING PROCESS; GYROSCOPIC WELLBORE MEASUREMENT TOOL, NAMELY, GYROSCOPE TOOL FOR MEASURING DIRECTION AND ORIENTATION OF A WELLBORE FOR THE OIL AND GAS, ENERGY, MINING, ENVIRONMENTAL AND CONSTRUCTION INDUSTRIES; DOWN HOLE GYROSCOPIC MEASUREMENT TOOL FOR OBTAINING DIRECTIONAL DRILLING CONTROL DATA FOR USE BY OTHERS FOR CONTROLLING THE DIRECTION OF WELLBORE DRILLING IN THE OIL AND GAS, ENERGY, MINING, ENVIRONMENTAL AND CONSTRUCTION INDUSTRIES; DIRECTIONAL DRILLING DATA COLLECTION AND ANALYSIS SOFTWARE FOR THE OIL AND GAS, ENERGY, MINING, ENVIRONMENTAL AND CONSTRUCTION INDUSTRIES; SOFTWARE FOR USE IN CONTROLLING THE DIRECTION OF WELLBORE DRILLING, NAMELY, SOFTWARE FOR COLLECTING AND ANALYZING WELLBORE DEPTH, ORIENTATION, AND DRILLING DIRECTION DATA FOR USE IN CONTROLLING DIRECTIONAL DRILLING OF A WELLBORE; AND ELECTRONIC WELLBORE DATA COLLECTOR, NAMELY, AN ELECTRONIC DEVICE FOR COLLECTION OF WELLBORE DIRECTION AND ORIENTATION DATA FROM WELLBORE MEASUREMENT DEVICES OF OTHERS IN THE OIL AND GAS, ENERGY, MINING, ENVIRONMENTAL AND CONSTRUCTION INDUSTRIES (U.S. CLS. 21, 23, 26, 36 AND 38).

RUSS HERMAN, EXAMINING ATTORNEY

SN 85-468,261. AVOX SYSTEMS INC., LANCASTER, NY. FILED 11-9-2011.



THE MARK CONSISTS OF THE WORD "INFINIOX" IN STYLIZED LETTERING WITH THE LETTER "O" INCORPORATING TWO CONTRAILS TRAILING AN AIRPLANE LOCATED TO THE UPPER LEFT OF THE LETTER "O".

FOR SAFETY EQUIPMENT, NAMELY, A GENERAL AVIATION ON-BOARD OXYGEN GENERATOR SYSTEM CONSISTING OF AN OXYGEN GENERATOR, SENSOR MODULE, MANIFOLD WITH OUTLETS AND AN OXYGEN MASK (U.S. CLS. 21, 23, 26, 36 AND 38).

LINDA M. KING, EXAMINING ATTORNEY

CLASS 9—(Continued).

SN 85-469,185. JWIN ELECTRONICS CORP., DBA ILUV CREATIVE TECHNOLOGY, PORT WASHINGTON, NY. FILED 11-10-2011.

myStyle

THE MARK CONSISTS OF STANDARD CHARACTERS WITHOUT CLAIM TO ANY PARTICULAR FONT, STYLE, SIZE, OR COLOR.

FOR BAGS AND CASES SPECIALLY ADAPTED FOR HOLDING OR CARRYING PORTABLE TELEPHONES AND TELEPHONE EQUIPMENT AND ACCESSORIES; BATTERY CASES; BEEPER CARRYING CASES; CD CASES; CARRYING CASES FOR ELECTRONIC EQUIPMENT, NAMELY, CELL PHONES AND TABLET COMPUTERS; CD CASES (U.S. CLS. 21, 23, 26, 36 AND 38).
IRA J. GOODSaid, EXAMINING ATTORNEY

SN 85-469,197. JWIN ELECTRONICS CORP., DBA ILUV CREATIVE TECHNOLOGY, PORT WASHINGTON, NY. FILED 11-10-2011.

myPower

THE MARK CONSISTS OF STANDARD CHARACTERS WITHOUT CLAIM TO ANY PARTICULAR FONT, STYLE, SIZE, OR COLOR.

FOR AUTOMATED PROCESS CONTROL SYSTEM, NAMELY, MICRO-PROCESSOR BASED HARDWARE AND SOFTWARE USED TO MONITOR THE STATUS OF INDUSTRIAL PROCESSES, NAMELY POWER GENERATION, ELECTRICAL DISTRIBUTION AND OIL AND GAS PROCESSING; BATTERY POWER SUPPLIES FOR MEDICAL VENTILATORS; BATTERY POWERED METER FOR MEASURING THE MOISTURE CONTENT OF COFFEE BEANS; BATTERY-POWERED APPLICATORS FOR APPLYING COSMETICS TO EYELASHES; BROADBAND POWER LINE COMMUNICATION SYSTEMS FOR TRANSFERRING BROADBAND DATA OVER ELECTRICAL POWER LINES, COMPRISED OF COMPUTER HARDWARE, SOFTWARE AND MODEMS; CAMERAS FOR MONITORING AND INSPECTING EQUIPMENT IN A NUCLEAR POWER STATION; CARRYING CASES, HOLDERS, PROTECTIVE CASES AND STANDS FEATURING POWER SUPPLY CONNECTORS, ADAPTORS, SPEAKERS AND BATTERY CHARGING DEVICES, SPECIALLY ADAPTED FOR USE WITH HANDHELD DIGITAL ELECTRONIC DEVICES; CONDUCTIVE FIBERS, NAMELY, HIGH POWER FIBERS FOR CONDUCTING LASER BEAMS IN THE MID INFRARED WAVELENGTH RANGE; CONSUMER ELECTRONIC PRODUCTS, NAMELY, AUDIO AMPLIFIERS, AUDIO SPEAKERS, AUDIO RECEIVERS, ELECTRICAL AUDIO AND SPEAKER CABLES AND CONNECTORS, AUDIO DECODERS, VIDEO DECODERS, SPEAKERS, POWER CONVERSION DEVICES, POWER CONVERTERS, AND POWER INVERTERS; DAY AND NIGHT VISION SYSTEMS PRIMARILY COMPRISING DAY AND NIGHT SENSORS, DAY AND NIGHT CAMERAS, POWER SOURCES, COMMUNICATION MEANS, MONITORS AND OPERATING SOFTWARE; DC/AC POWER CONVERTERS; DIGITAL SWITCHING SYSTEMS COMPRISED OF INTERCONNECTED ELECTROMECHANICAL AND SOLID-STATE POWER MANAGEMENT ENCLOSURES WITH STANDARD AND CUSTOM KEYPADS FOR USER REMOTE CONTROL, THE FOREGOING FOR USE ON MARINE

CLASS 9—(Continued).

HELMS AND LAND-BASED VEHICLE DASHBOARDS; DISTRIBUTION BOXES FOR ELECTRICAL POWER; ELECTRIC POWER CONVERTERS; ELECTRIC POWERED SOLDERING IRONS; ELECTRICAL DISTRIBUTION SYSTEMS, NAMELY, POWER DISTRIBUTION PANELS; ELECTRICAL PLUG DEVICE ENABLING CONNECTION AND DISCONNECTION OF POWER AND/OR CONTROL CABLES; ELECTRICAL POWER CONNECTORS; ELECTRICAL POWER DEVICES, NAMELY, MULTIMEDIA OUTLETS; ELECTRICAL POWER DEVICES, NAMELY, TAPS; ELECTRICAL POWER DISTRIBUTION BLOCKS; ELECTRICAL POWER DISTRIBUTION UNITS; ELECTRICAL POWER EXTENSION CORDS; ELECTRICAL SWITCHGEAR, NAMELY, VOLTAGE BOOSTING DEVICES FOR ELECTRIC POWER LINES; ELECTRICAL VOICE INTRACOMMUNICATIONS SYSTEMS COMPRISING CONTROL STATIONS, INTERFACE MODULES, FRAMES, CONTROLLER CARDS, CONNECTORS, POWER SUPPLIES, PANELS AND MOUNTINGS FOR USE IN THE PRODUCTION OF LIVE MUSICAL PERFORMANCES, THEATRE, AND OTHER LIVE EVENTS; ELECTRONIC CONTROLLER TO MANAGE THE POWER, MOVEMENT AND FUNCTIONS OF AN ELEVATOR; ELECTRONIC CONTROLLERS FOR USE WITH POWER CONVERTERS; ELECTRONIC CONTROLLERS USED TO REDUCE POWER CONSUMPTION; ELECTRONIC GLASS AND CERAMIC FUSES FOR USE WITH ANY ELECTRONIC EQUIPMENT USING A/C POWER; ELECTRONIC POWER SUPPLIES FOR DRIVING ELECTRIC MOTORS; ELECTRONIC RECORDERS FOR STORING AND ARCHIVING INFORMATION RELATED TO POWER SYSTEM FAULTS; GATE OPERATORS POWERED BY BATTERY, ELECTRICITY OR SOLAR POWER; HEADWALL GAS AND ELECTRICITY DISTRIBUTION UNITS COMPRISING POWER STRIPS, SURGE PROTECTORS OR ELECTRICAL POWER DISTRIBUTION APPARATUS FOR USE IN HOSPITAL FACILITIES; HIGH-FREQUENCY SWITCHING POWER SUPPLIES; LASER DEVICE FOR PROJECTING A VISIBLE LINE ON A WORK PIECE TO BE CUT BY A ROTARY POWER SAW; LOW PASS INDUCTOR FILTER USED IN HIGH POWER ELECTRICAL APPLICATIONS; MAGNETS ARRANGED FOR CONVERTING HUMAN EFFORT INTO MECHANICAL POWER; MEDIUM VOLTAGE POWER DISTRIBUTION AND PROTECTION COMPONENT SYSTEM COMPOSED OF BREAKERS AND SWITCHGEARS; MICROPROCESSOR-BASED HARDWARE SYSTEMS USED TO REDUCE POWER CONSUMPTION; POWER ACCESS PORT FOR USE WITH ELECTRICAL CONTROL PANELS FOR CONNECTING MULTIPLE DATA AND ELECTRICAL DEVICES; POWER ADAPTERS; POWER ADAPTERS FOR COMPUTERS; POWER AMPLIFIERS; POWER CABLES; POWER CONNECTORS; POWER CONTROLLERS; POWER DISTRIBUTING BOXES; POWER FACTOR REGULATOR TO ECONOMIZE THE DELIVERY OF ELECTRICAL POWER IN THE NATURE OF A ROD CONTAINING MINERALS CONTAINED IN A PVC TUBE; POWER INVERTERS; POWER LINE CONDITIONERS; POWER SUPPLIES (U.S. CLS. 21, 23, 26, 36 AND 38).

IRA J. GOODSaid, EXAMINING ATTORNEY

CLASS 9—(Continued).

SN 85-469,332. JWLN ELECTRONICS CORP., DBA ILUV CREATIVE TECHNOLOGY, PORT WASHINGTON, NY. FILED 11-10-2011.

myMusic

THE MARK CONSISTS OF STANDARD CHARACTERS WITHOUT CLAIM TO ANY PARTICULAR FONT, STYLE, SIZE, OR COLOR.

FOR ABDOMINAL BELTS CONTAINING BUILT-IN SPEAKERS FOR PURPOSES OF TRANSMITTING MUSIC/SOUNDS; EDUCATIONAL MATERIAL TO A FETUS AND BUILT-IN POCKETS IN WHICH TO CARRY AUDIO TRANSMITTERS; AUDIO AMPLIFIERS; AUDIO AND VIDEO CASSETTE RECORDERS; AUDIO AND VIDEO RECORDINGS ABOUT TENNIS; AUDIO AND VIDEO RECORDINGS FEATURING MUSIC AND ARTISTIC PERFORMANCES; AUDIO AND VISUAL HEADSETS FOR USE IN PLAYING VIDEO GAMES; AUDIO BOOKS IN THE NATURE OF NOVELS; AUDIO CABLES; AUDIO CASSETTE AND CD PLAYERS; AUDIO CASSETTE DECKS FOR AUTOMOBILES; AUDIO CASSETTE PLAYERS; AUDIO CASSETTE RECORDERS; AUDIO CIRCUIT BOARDS; AUDIO HEADPHONES; EARPHONE ACCESSORIES, NAMELY, EARPHONE CUSHIONS, EARPHONE PADS, CORD MANAGEMENT SYSTEMS, EARPHONE CASES, AND EARPHONE EXTENSION CORDS; EARPHONES; EARPHONES AND HEADPHONES; HEADPHONES; HEADPHONES INCLUDING ATTACHED LANYARD; LOUDSPEAKERS, HEADPHONES, MICROPHONES AND CD PLAYERS; MUSIC HEADPHONES; PERSONAL HEADPHONES FOR SOUND TRANSMITTING APPARATUSES; PERSONAL HEADPHONES FOR USE WITH SOUND TRANSMITTING SYSTEMS; STEREO HEADPHONES (U.S. CLS. 21, 23, 26, 36 AND 38).

IRA J. GOODSaid, EXAMINING ATTORNEY

CLASS 9—(Continued).

SN 85-469,356. JWLN ELECTRONICS CORP., DBA ILUV CREATIVE TECHNOLOGY, PORT WASHINGTON, NY. FILED 11-10-2011.

myEssentials

THE MARK CONSISTS OF STANDARD CHARACTERS WITHOUT CLAIM TO ANY PARTICULAR FONT, STYLE, SIZE, OR COLOR.

FOR ACCESSORIES FOR LIGHTING FIXTURES, NAMELY, PLASTIC POLE WITH ELECTRICAL SOURCE IN PROTECTIVE COVER; BAGS AND CASES SPECIALLY ADAPTED FOR HOLDING OR CARRYING PORTABLE TELEPHONES AND TELEPHONE EQUIPMENT AND ACCESSORIES; CAMERA STABILITY ACCESSORY, NAMELY, A SUPPORT ARM, VEST AND SLED FOR FILM AND VIDEO CAMERAS TO ABSORB SHAKING MOVES WHILE SHOOTING; CELLULAR PHONE ACCESSORY CHARMS; COMPUTER STANDS SPECIALLY DESIGNED FOR HOLDING A COMPUTER, PRINTER AND ACCESSORIES; DIGITAL CAMERA ACCESSORY IN THE NATURE OF A DIGITAL PHOTO VIEWER; EARPHONE ACCESSORIES, NAMELY, EARPHONE CUSHIONS, EARPHONE PADS, CORD MANAGEMENT SYSTEMS, EARPHONE CASES, AND EARPHONE EXTENSION CORDS; MAGNETIC HEAD CLEANERS; MAGNETIC TAPE CLEANERS; MAINTENANCE KITS FOR SCANNERS COMPRISED PRIMARILY OF SETS OF REPLACEMENT PARTS FOR SCANNERS, NAMELY, PICK ROLLERS, SEPARATION ROLLERS, BRAKE ROLLERS AND PAD ASSEMBLIES AND ALSO INCLUDING CLEANING KITS FOR SCANNERS COMPRISED OF LIQUID CLEANERS, CLEANING SHEETS, CLEANING PAPERS, CLEANING WIPES, CLEANING CLOTHS AND CLEANING SWABS; MOBILE TELEPHONE ACCESSORIES, NAMELY, BELT CLIPS; PHOTOGRAPHIC ACCESSORY, NAMELY, FILM BACKS; PUBLIC ADDRESS (PA) AND SOUND SYSTEM ACCESSORIES, NAMELY, MICROPHONE STANDS, SPEAKER STANDS, MICROPHONE CABLES, SPEAKER CABLES, SPEAKER BOXES AND SOUND MIXERS (U.S. CLS. 21, 23, 26, 36 AND 38).

IRA J. GOODSaid, EXAMINING ATTORNEY

CLASS 9—(Continued).

SN 85-469,399. JWIN ELECTRONICS CORP., DBA ILUV CREATIVE TECHNOLOGY, PORT WASHINGTON, NY. FILED 11-10-2011.

DreamTraveler

THE MARK CONSISTS OF STANDARD CHARACTERS WITHOUT CLAIM TO ANY PARTICULAR FONT, STYLE, SIZE, OR COLOR.

FOR CIRCUIT OVERLOAD PROTECTOR DEVICES; DISPLAY PROTECTOR TO PROVIDE SHADE AND PRIVACY FOR ELECTRONIC DEVICES HAVING SCREENS; PRE-PACKAGED KITS CONTAINING ELECTRICAL PROTECTION DEVICES IN THE NATURE OF INSULATORS, CORONA RINGS, ARMOR-RODS AND SURGE ARRESTERS AND METAL HARDWARE IN THE NATURE OF SUSPENSION CLAMPS, YOKE PLATES, ALL OF WHICH ATTACH OR CONNECT TRANSMISSION CONDUCTORS TO HIGH VOLTAGE ELECTRIC TRANSMISSION TOWERS; TELEVISION SCREEN PROTECTORS IN THE NATURE OF ACRYLIC SHIELDS TO BE MOUNTED OVER TELEVISION SCREENS; TRANSIENT VOLTAGE SURGE SUPPRESSORS WITH POWER CONDITIONING TECHNOLOGY; VOLTAGE SURGE PROTECTORS; VOLTAGE SURGE SUPPRESSORS (U.S. CLS. 21, 23, 26, 36 AND 38).

IRA J. GOODSaid, EXAMINING ATTORNEY

CLASS 9—(Continued).

SN 85-474,507. SOURCE INTERLINK MAGAZINES, LLC, EL SEGUNDO, CA. FILED 11-16-2011.

MUD LIFE

THE MARK CONSISTS OF STANDARD CHARACTERS WITHOUT CLAIM TO ANY PARTICULAR FONT, STYLE, SIZE, OR COLOR.

OWNER OF U.S. REG. NO. 3,748,352.
 NO CLAIM IS MADE TO THE EXCLUSIVE RIGHT TO USE "MUD", APART FROM THE MARK AS SHOWN.
 FOR DOWNLOADABLE ELECTRONIC PUBLICATIONS IN THE NATURE OF MAGAZINES IN THE FIELD OF MUD TRUCKS, MUD TRUCK COMPETITIONS, EXHIBITIONS, AND EVENTS FEATURING MUD TRUCKS, ALL-TERRAIN VEHICLES, AND OTHER OFF-ROAD VEHICLES; DOWNLOADABLE SOFTWARE IN THE NATURE OF A MOBILE APPLICATION FOR MAGAZINES FEATURING MUD TRUCKS, MUD TRUCK COMPETITIONS, EXHIBITIONS, AND EVENTS FEATURING MUD TRUCKS, ALL-TERRAIN VEHICLES, AND OTHER OFF-ROAD VEHICLES (U.S. CLS. 21, 23, 26, 36 AND 38).

FONG HSU, EXAMINING ATTORNEY

SN 85-473,349. KIDZOUT, INC., BUFFALO, WY. FILED 11-15-2011.



THE MARK CONSISTS OF FOUR INDIVIDUAL ILLUSTRATIONS OF A CROSS, SYMBOLS OF TWO HUMANLIKE FIGURES ENGAGED IN PLAY ACTIVITIES, AN ILLUSTRATION OF A DIAPER UNDERGARMENT AND AN ILLUSTRATION OF THREE HUMANLIKE FIGURES ALONGSIDE KITCHEN UTENSILS, EACH AREA OF WHICH IS COMBINED INTO A LARGER SQUARE WITH ROUNDED EDGES.

FOR COMPUTER APPLICATION SOFTWARE FOR MOBILE PHONES, NAMELY, SOFTWARE FOR DISPLAYING LOCATION BASED INFORMATION (U.S. CLS. 21, 23, 26, 36 AND 38).

FIRST USE 5-2-2011; IN COMMERCE 5-2-2011.
 HEATHER THOMPSON, EXAMINING ATTORNEY

SN 85-476,558. ARMORWORKS ENTERPRISES, LLC, CHANDLER, AZ. FILED 11-18-2011.

K-FLEX

THE MARK CONSISTS OF STANDARD CHARACTERS WITHOUT CLAIM TO ANY PARTICULAR FONT, STYLE, SIZE, OR COLOR.

FOR PROTECTIVE BALLISTIC RESISTANT FABRICS SOLD AS AN INTEGRAL COMPONENT OF HARD AND SOFT ARMOR (U.S. CLS. 21, 23, 26, 36 AND 38).

ERIN FALK, EXAMINING ATTORNEY

SN 85-476,567. ARMORWORKS ENTERPRISES, LLC, CHANDLER, AZ. FILED 11-18-2011.

FLEX-TECH

THE MARK CONSISTS OF STANDARD CHARACTERS WITHOUT CLAIM TO ANY PARTICULAR FONT, STYLE, SIZE, OR COLOR.

FOR PROTECTIVE BALLISTIC RESISTANT FABRICS SOLD AS AN INTEGRAL COMPONENT OF HARD AND SOFT ARMOR (U.S. CLS. 21, 23, 26, 36 AND 38).

ERIN FALK, EXAMINING ATTORNEY

CLASS 9—(Continued).

SN 85-477,518. HTC CORPORATION, TAOYUAN CITY, TAIWAN, FILED 11-21-2011.

HTC ONE

THE MARK CONSISTS OF STANDARD CHARACTERS WITHOUT CLAIM TO ANY PARTICULAR FONT, STYLE, SIZE, OR COLOR.

OWNER OF U.S. REG. NOS. 3,584,881, 3,919,900 AND OTHERS.

FOR MOBILE PHONES, SMARTPHONES, CELLULAR PHONES, PORTABLE COMPUTERS, TABLET COMPUTERS, AND PERSONAL DIGITAL ASSISTANTS AND WIRELESS HANDHELD DIGITAL ELECTRONIC DEVICES FOR COMMUNICATING, RECORDING, ORGANIZING, TRANSMITTING, MANIPULATING, STORING, AND REVIEWING TEXT, DATA, IMAGE, AND AUDIO FILES (U.S. CLS. 21, 23, 26, 36 AND 38).

MEGHAN REINHART, EXAMINING ATTORNEY

SN 85-477,523. HTC CORPORATION, TAOYUAN CITY, TAIWAN, FILED 11-21-2011.

HTC ONE

THE MARK CONSISTS OF STANDARD CHARACTERS WITHOUT CLAIM TO ANY PARTICULAR FONT, STYLE, SIZE, OR COLOR.

OWNER OF U.S. REG. NOS. 3,584,881, 3,919,900 AND OTHERS.

FOR COMPUTER HARDWARE AND SOFTWARE FOR ENABLING, OPERATING, ENHANCING, CUSTOMIZING, UPDATING AND MANAGING MOBILE, PORTABLE, SMART, VOICE-OVER-INTERNET-PROTOCOL, AND WIRELESS TELEPHONES, TABLET COMPUTERS AND WIRELESS DEVICES; USER INTERFACE SOFTWARE; COMPUTER HARDWARE AND SOFTWARE FOR DELIVERING, ENABLING, CREATING, ENHANCING, CUSTOMIZING, UPDATING, AND MANAGING USER INTERFACING, TELECOMMUNICATIONS AND TELECOMMUNICATIONS SERVICES; COMPUTER HARDWARE AND SOFTWARE FOR TRANSMITTING AND RECEIVING VOICE, IMAGE, DATA, AUDIO, VIDEO AND MULTIMEDIA CONTENT; WIRELESS MODEMS; ACCESSORIES FOR THE ABOVE GOODS, NAMELY, HEADSETS, HEADSETS WITH WIRELESS TRANSMISSION FUNCTION, CONNECTION CABLES, STYLUS PENS, PHONE AND WIRELESS COMMUNICATION DEVICE CRADLES, IN-CAR PHONE MOUNTS, FACE PLATES, REPLACEMENT PARTS FOR THE ABOVE-LISTED GOODS, BATTERIES, POWER ADAPTORS, PHONE AND WIRELESS COMMUNICATION DEVICE CHARGERS, CASES, POUCHES, IN-VEHICLE PHONE AND WIRELESS COMMUNICATION DEVICE CHARGERS, IN-VEHICLE HOLDERS, REMOTE CONTROLS, KEYBOARDS, MICROPHONES, AND LOUD-SPEAKERS (U.S. CLS. 21, 23, 26, 36 AND 38).

MEGHAN REINHART, EXAMINING ATTORNEY

CLASS 9—(Continued).

SN 85-484,674. MAYTAG PROPERTIES, LLC, ST. JOSEPH, MI. FILED 12-1-2011.

ADMIRAL

THE MARK CONSISTS OF STANDARD CHARACTERS WITHOUT CLAIM TO ANY PARTICULAR FONT, STYLE, SIZE, OR COLOR.

OWNER OF U.S. REG. NOS. 549,908 AND 780,906.

FOR DIGITAL VERSATILE DISC PLAYER; DVD PLAYERS; OPTICAL DISC PLAYERS; PROGRAMMABLE DIGITAL TELEVISION RECORDERS; REMOTE CONTROLS FOR TELEVISIONS, DVDS, DISC PLAYERS; TELEVISIONS; VIDEO DISC PLAYERS (U.S. CLS. 21, 23, 26, 36 AND 38).

DAVID H. STINE, EXAMINING ATTORNEY

SN 85-486,304. IGT, RENO, NV. FILED 12-2-2011.

NO DRAWING-SENSORY MARK

THE MARK IS A SOUND. THE MARK CONSISTS OF A THREE BEAT MELODY AND HARMONY. THE FIRST BEAT CONSISTS OF A BB5 CHORD HELD FOR A QUARTER NOTE WITH ADDITIONAL BB5 AND F5 EIGHTH NOTES PLAYED ON THE SECOND HALF OF THE BEAT. THE SECOND BEAT CONSISTS OF A BB CHORD BROKEN INTO AN EIGHTH NOTE PATTERN WHILE THE MELODY PLAYS AN F5 EIGHTH NOTE AND A BB5 EIGHTH NOTE. THE THIRD BEAT CONSISTS OF AN EB5 CHORD WITH A G5 QUARTER NOTE IN THE MELODY. THE ORCHESTRATION USED INCORPORATES PIZZICATO CELLOS, MARIMBAS, STEREO MODELING SYNTHESIZERS, BEACH BELL SYNTHESIZERS, AND AN ELECTRIC PIANO.

FOR GAMING MACHINES, NAMELY, DEVICES WHICH ACCEPT A WAGER (U.S. CLS. 21, 23, 26, 36 AND 38).

JASON BLAIR, EXAMINING ATTORNEY

SN 85-487,216. SUNBEAM PRODUCTS, INC., BOCA RATON, FL. FILED 12-5-2011.

TSCH!

THE MARK CONSISTS OF STANDARD CHARACTERS WITHOUT CLAIM TO ANY PARTICULAR FONT, STYLE, SIZE, OR COLOR.

FOR PET TRAINING DEVICE, NAMELY, A DEVICE THAT EMITS A SOUND THROUGH COMPRESSED GAS IN ORDER TO CONTROL A PET'S BEHAVIOR (U.S. CLS. 21, 23, 26, 36 AND 38).

JULIE GUTTADAURO, EXAMINING ATTORNEY

CLASS 9—(Continued).

SN 85-490,919. AMERICAN ACADEMY OF OPHTHALMOLOGY, INC., SAN FRANCISCO, CA. FILED 12-8-2011.

CLASS 9—(Continued).

SN 85-496,080. HTC CORPORATION, TAOYUAN CITY, TAIWAN, FILED 12-15-2011.

PREFERRED PRACTICE PATTERN

HTC FIERCE

THE MARK CONSISTS OF STANDARD CHARACTERS WITHOUT CLAIM TO ANY PARTICULAR FONT, STYLE, SIZE, OR COLOR.

OWNER OF U.S. REG. NO. 2,078,278. SEC. 2(F).

FOR ELECTRONIC DOWNLOADABLE PUBLICATIONS, NAMELY, INSTRUCTIONAL, EDUCATIONAL AND TEACHING MATERIALS ON THE SUBJECT OF EYE CARE (U.S. CLS. 21, 23, 26, 36 AND 38).

FIRST USE 8-31-2000; IN COMMERCE 8-31-2000. ZHALEH DELANEY, EXAMINING ATTORNEY

THE MARK CONSISTS OF STANDARD CHARACTERS WITHOUT CLAIM TO ANY PARTICULAR FONT, STYLE, SIZE, OR COLOR.

OWNER OF U.S. REG. NOS. 3,584,881, 3,919,900 AND OTHERS.

FOR MOBILE PHONES, SMARTPHONES, CELLULAR PHONES, PORTABLE COMPUTERS, TABLET COMPUTERS, AND PERSONAL DIGITAL ASSISTANTS AND WIRELESS HANDHELD DIGITAL ELECTRONIC DEVICES FOR COMMUNICATING, RECORDING, ORGANIZING, TRANSMITTING, MANIPULATING, STORING, AND REVIEWING TEXT, DATA, IMAGE, AND AUDIO FILES (U.S. CLS. 21, 23, 26, 36 AND 38). MEGHAN REINHART, EXAMINING ATTORNEY

SN 85-495,684. LDC INTERNATIONAL CORPORATION, NEW CASTLE COUNTY, DE. FILED 12-14-2011.

SN 85-499,045. NATIONAL CINEMEDIA, LLC, CENTENNIAL, CO. FILED 12-19-2011.



Let Details in Control

CINEMA SYNC

THE MARK CONSISTS OF A ROTUNDITY WITH HOLLOWED CURVES IN, UPON THE WORDING "LET DETAILS IN CONTROL".

FOR CABLE CONNECTORS; COMPUTER NETWORK ADAPTERS, SWITCHES, ROUTERS AND HUBS; DIGITAL TELEPHONE SWITCHING APPARATUS; ELECTRIC CABLES AND WIRES; ELECTRONIC AND OPTICAL COMMUNICATIONS INSTRUMENTS AND COMPONENTS, NAMELY, OPTICAL TRANSCEIVERS; FIBRE-OPTIC CABLES (U.S. CLS. 21, 23, 26, 36 AND 38). MAYUR VAGHANI, EXAMINING ATTORNEY

THE MARK CONSISTS OF STANDARD CHARACTERS WITHOUT CLAIM TO ANY PARTICULAR FONT, STYLE, SIZE, OR COLOR.

NO CLAIM IS MADE TO THE EXCLUSIVE RIGHT TO USE "CINEMA", APART FROM THE MARK AS SHOWN.

FOR DOWNLOADABLE SOFTWARE APPLICATION FOR MOBILE AND TABLET DEVICES AND ELECTRONIC COMMUNICATION NETWORKS THAT ENABLES USERS TO OBTAIN AND SHARE INFORMATION ABOUT MOTION PICTURES AND PROVIDES INTERACTIVE ENHANCEMENTS TO MOTION PICTURE VIEWING (U.S. CLS. 21, 23, 26, 36 AND 38). WILLIAM VERHOSEK, EXAMINING ATTORNEY

CLASS 9—(Continued).

SN 85-500,812. CRYTEK GMBH, FRANKFURT AM MAIN, FED REP GERMANY, FILED 12-21-2011.



THE COLOR(S) BLUE, LIGHT BLUE, BLACK, WHITE IS/ ARE CLAIMED AS A FEATURE OF THE MARK.

THE MARK CONSISTS OF A BLUE ROUNDED-EDGE SQUARE SHAPE PARTIALLY OVERLAIN BY A WHITE RING, A CONCENTRIC LIGHT BLUE RING WITHIN THE WHITE RING, AND A BLACK CIRCLE FILLING THE CENTER OF THE LIGHT BLUE RING.

FOR COMPUTER SOFTWARE DEVELOPMENT TOOLS; COMPUTER SOFTWARE TO ENHANCE THE AUDIO-VISUAL CAPABILITIES OF MULTIMEDIA APPLICATIONS, NAMELY, FOR THE INTEGRATION OF TEXT, AUDIO, GRAPHICS, STILL IMAGES AND MOVING PICTURES; COMPUTER GAME SOFTWARE; COMPUTER GRAPHICS SOFTWARE; VIDEO GAME SOFTWARE; VIRTUAL REALITY GAME SOFTWARE; COMPUTER COMMUNICATIONS SOFTWARE TO ALLOW USERS TO PARTICIPATE IN VIDEO AND COMPUTER GAME SESSIONS VIA ONLINE NETWORK TRANSMISSION OR MULTIMEDIA ELECTRONIC BROADCAST; DOWNLOADABLE ELECTRONIC PUBLICATIONS IN THE NATURE OF MANUALS, BROCHURES, NEWSLETTERS AND MAGAZINES IN THE FORM OF PDF-FILES OR STANDARD FILE FORMATS SO AS TO BE READABLE BY COMMERCIAL OFFICE APPLICATIONS FEATURING INFORMATION IN THE FIELDS OF COMPUTER SOFTWARE DEVELOPMENT TOOLS, COMPUTER SOFTWARE TO ENHANCE THE AUDIO-VISUAL CAPABILITIES OF MULTIMEDIA APPLICATIONS, NAMELY, FOR THE INTEGRATION OF TEXT, AUDIO, GRAPHICS, STILL IMAGES AND MOVING PICTURES, COMPUTER GAME SOFTWARE, COMPUTER GRAPHICS SOFTWARE, VIDEO GAME SOFTWARE, VIRTUAL REALITY GAME SOFTWARE, COMPUTER COMMUNICATIONS SOFTWARE TO ALLOW USERS TO PARTICIPATE IN GAME SESSIONS VIA ONLINE NETWORK TRANSMISSION OR MULTIMEDIA ELECTRONIC BROADCAST; ELECTRONIC DATA CARRIERS PRE-RECORDED WITH SOFTWARE IN THE FIELDS OF COMPUTER SOFTWARE DEVELOPMENT TOOLS, COMPUTER SOFTWARE TO ENHANCE THE AUDIOVISUAL CAPABILITIES OF MULTIMEDIA APPLICATIONS, NAMELY, FOR THE INTEGRATION OF TEXT, AUDIO, GRAPHICS, STILL IMAGES AND MOVING PICTURES, COMPUTER GAME SOFTWARE, COMPUTER GRAPHICS SOFTWARE, VIDEO GAME SOFTWARE, VIRTUAL REALITY GAME SOFTWARE, COMPUTER COMMUNICATIONS SOFTWARE TO ALLOW USERS TO PARTICIPATE IN GAME SESSIONS VIA ONLINE NETWORK TRANSMISSION OR MULTIMEDIA ELECTRONIC BROADCAST. DATA PROCESSING EQUIPMENT, NAMELY, COMPUTERS, VIDEO GAME CONSOLES FOR USE WITH AN EXTERNAL DISPLAY SCREEN OR MONITOR AND HARDWARE COMPONENTS FOR THE AFORESAID GOODS, NAMELY, INTEGRATED CIRCUITS, APPLICATION SPECIFIC INTEGRATED CIRCUITS, DATA PROCESSORS AND GRAPHICS PROCESSORS; AND PRINTED MATTER IN THE FIELD OF THE FOREGOING SOFTWARE, IN THE NATURE OF BOOKS, BROCHURES, FLY SHEETS, LEAFLETS, INSTRUCTIONAL AND TEACHING MATERIAL, EXCEPT APPARATUS, ALL SOLD AS A UNIT WITH THE AFORESAID GOODS (U.S. CLS. 21, 23, 26, 36 AND 38).

JAMES A. RAUEN, EXAMINING ATTORNEY

CLASS 9—(Continued).

SN 85-502,501. CIRRUS HEALTHCARE PRODUCTS, L.L.C., COLD SPRING HARBOR, NY. FILED 12-22-2011.

SILENCE FOAM

THE MARK CONSISTS OF STANDARD CHARACTERS WITHOUT CLAIM TO ANY PARTICULAR FONT, STYLE, SIZE, OR COLOR.

NO CLAIM IS MADE TO THE EXCLUSIVE RIGHT TO USE "FOAM", APART FROM THE MARK AS SHOWN.

FOR EAR PLUGS FOR SLEEPING (U.S. CLS. 21, 23, 26, 36 AND 38).

MATTHEW KLINE, EXAMINING ATTORNEY

SN 85-503,284. VMWARE, INC., PALO ALTO, CA. FILED 12-23-2011.

vCloud Director

THE MARK CONSISTS OF STANDARD CHARACTERS WITHOUT CLAIM TO ANY PARTICULAR FONT, STYLE, SIZE, OR COLOR.

OWNER OF U.S. REG. NOS. 3,845,770 AND 3,886,823.

FOR SOFTWARE FOR PROVIDING INTERFACE AND MANAGEMENT FEATURES THAT ENABLE A CLOUD COMPUTING MANAGEMENT PLATFORM (U.S. CLS. 21, 23, 26, 36 AND 38).

FIRST USE 8-0-2010; IN COMMERCE 8-0-2010.

ZACHARY BELLO, EXAMINING ATTORNEY

SN 85-503,304. VMWARE, INC., PALO ALTO, CA. FILED 12-23-2011.

APPBLAST

THE MARK CONSISTS OF STANDARD CHARACTERS WITHOUT CLAIM TO ANY PARTICULAR FONT, STYLE, SIZE, OR COLOR.

FOR SOFTWARE FOR PROVIDING MANAGEMENT, CONVERSION AND TRANSMISSION OF ELECTRONIC DATA COMMUNICATION THROUGH A WEB BROWSER (U.S. CLS. 21, 23, 26, 36 AND 38).

ZACHARY BELLO, EXAMINING ATTORNEY

CLASS 9—(Continued).

SN 85-507,724. OLYMPUS CORPORATION, TOKYO, JAPAN, FILED 1-3-2012.

OM-D

THE MARK CONSISTS OF STANDARD CHARACTERS WITHOUT CLAIM TO ANY PARTICULAR FONT, STYLE, SIZE, OR COLOR.

FOR CAMERAS; DIGITAL CAMERAS; INTERCHANGEABLE LENSES FOR CAMERAS; EXTENSION AND CONVERSION LENSES FOR CAMERAS; LENS FILTERS; LENS HOODS; LENS CAPS; CAMERA LENS SUPPORT ARMS; ELECTRONIC FLASHES FOR CAMERAS; CAMERA FLASH BRACKETS; BATTERIES AND ELECTRICAL CELLS; BATTERY CHARGERS; ALTERNATING CURRENT ADAPTERS; POWER BATTERY HOLDERS; REMOTE CONTROLS FOR CAMERAS; FOCUSING SCREENS FOR CAMERAS; MOUNT ADAPTERS FOR CAMERAS; EYECUPS FOR CAMERAS; HOODS FOR LIQUID CRYSTAL DISPLAYS OF CAMERAS; CAMERA CASES; CAMERA STRAPS; WATER PROOF PROTECTORS FOR CAMERAS BEING CASES AND COVERS; MEMORY CARDS; ADAPTERS FOR MEMORY CARDS; COMPUTER SOFTWARE FOR VIEWING, MANAGING AND EDITING IMAGES AND SOUNDS (U.S. CLS. 21, 23, 26, 36 AND 38).

APRIL ROACH, EXAMINING ATTORNEY

SN 85-513,023. FISSION LLC, NEW YORK, NY. FILED 1-10-2012.

NOOK OS

THE MARK CONSISTS OF STANDARD CHARACTERS WITHOUT CLAIM TO ANY PARTICULAR FONT, STYLE, SIZE, OR COLOR.

OWNER OF U.S. REG. NOS. 4,013,524 AND 4,023,198.

NO CLAIM IS MADE TO THE EXCLUSIVE RIGHT TO USE "OS", APART FROM THE MARK AS SHOWN.

FOR COMPUTER OPERATING PROGRAMS, OPERATING SYSTEMS AND FIRMWARE FOR USE IN CONNECTION WITH ELECTRONIC BOOK READERS, TABLET COMPUTERS, HANDHELD ELECTRONIC APPARATUS AND PORTABLE ELECTRONIC APPARATUS, AND INSTRUCTIONAL MANUALS, SOLD AS A UNIT (U.S. CLS. 21, 23, 26, 36 AND 38).

EMILY CARLSEN, EXAMINING ATTORNEY

CLASS 9—(Continued).

SN 85-513,671. 745 LLC, BOSTON, MA. FILED 1-11-2012.

SEVEN45 STUDIOS

THE MARK CONSISTS OF STANDARD CHARACTERS WITHOUT CLAIM TO ANY PARTICULAR FONT, STYLE, SIZE, OR COLOR.

NO CLAIM IS MADE TO THE EXCLUSIVE RIGHT TO USE "STUDIOS", APART FROM THE MARK AS SHOWN.

FOR COMPUTER APPLICATION SOFTWARE FOR PORTABLE ELECTRONIC DEVICES, NAMELY, SOFTWARE FOR DOWNLOADING AND PLAYING GAMES; DOWNLOADING, STREAMING, RECORDING, UPLOADING, AND VIEWING VIDEO FILES; AND FOR DOWNLOADING, STREAMING, RECORDING, UPLOADING, AND PLAYING MUSIC FILES (U.S. CLS. 21, 23, 26, 36 AND 38).

HOWARD B. LEVINE, EXAMINING ATTORNEY

SN 85-517,366. DIGITAL INNOVATIONS, LLC, ARLINGTON HEIGHTS, IL. FILED 1-16-2012.

THE NEST

THE MARK CONSISTS OF STANDARD CHARACTERS WITHOUT CLAIM TO ANY PARTICULAR FONT, STYLE, SIZE, OR COLOR.

FOR SILICONE RUBBER, OR OTHER ELASTOMER, CASES TO STORE AND PROTECT EARBUDS (U.S. CLS. 21, 23, 26, 36 AND 38).

MIDGE BUTLER, EXAMINING ATTORNEY

SN 85-975,850. NIKKATSU CORPORATION, TOKYO, JAPAN, FILED 8-26-2011.



THE MARK CONSISTS OF THE WORDING SUSHI TYPHOON STYLIZED AND PLACED IN THE CENTER WITH WINGS AFFIXED TO AND PROTRUDING FROM THE RIGHT AND LEFT SIDE OF THE SUSHI TYPHOON WORDING.

FOR DOWNLOADABLE IMAGE FILES CONTAINING IMAGES OF PICTURES, SCENES AND CLIPS FROM MOTION PICTURES AND MOVIES IN THE FIELDS OF ACTION, LIVE ACTION, DRAMA, SUSPENSE, HORROR, THRILLER, SCIENCE FICTION AND COMEDY; PRE-RECORDED DIGITAL VIDEO DISCS AND VIDEO TAPES FEATURING MOTION PICTURES AND MOVIES, AND IMAGES, PICTURES AND CLIPS RELATED THERETO IN THE FIELDS OF ACTION, LIVE ACTION, DRAMA, SUSPENSE, HORROR, THRILLER, SCIENCE FICTION AND COMEDY; DOWNLOADABLE PICTURES, MOTION PICTURES, AND MOVIES ALL FEATURING ACTION, LIVE ACTION, DRAMA, SUSPENSE, HORROR, THRILLER, SCIENCE FICTION AND COMEDY; AMUSEMENT APPARATUS AND GAMES ADAPTED FOR USE WITH TELEVISION RECEIVERS OR WITH VIDEO OR COMPUTER MONITORS; AMUSE-

CLASS 9—(Continued).

MENT MACHINES, NAMELY, HAND-HELD ELECTRONIC GAME UNITS ADAPTED FOR USE WITH AN EXTERNAL DISPLAY SCREEN OR MONITOR; AUDIO AND VISUAL HEADSETS FOR USE IN PLAYING VIDEO GAMES; COMPUTER GAME JOYSTICKS; COMPUTER GAME PROGRAMS, CARTRIDGES, AND CASSETTES; COMPUTER GAME SOFTWARE; COMPUTER GAME SOFTWARE FOR PERSONAL COMPUTERS AND HOME VIDEO GAME CONSOLES; COMPUTER GAME SOFTWARE FOR USE ON MOBILE AND CELLULAR PHONES; COMPUTER GAME TAPES; COMPUTER PROGRAMS FOR PRE-RECORDED GAMES; COMPUTER PROGRAMS FOR VIDEO AND COMPUTER GAMES; DOWNLOADABLE ELECTRONIC GAME PROGRAMS; ELECTRONIC GAME PROGRAMS; ELECTRONIC GAME PROGRAMS, NAMELY, ARCADE-TYPE ELECTRONIC GAME PROGRAMS; ELECTRONIC GAME SOFTWARE; HAND-HELD ELECTRONIC GAMES ADAPTED FOR USE WITH TELEVISION RECEIVERS ONLY; INTERACTIVE MULTIMEDIA COMPUTER GAME PROGRAM; INTERACTIVE MUSIC MANUSCRIPT IN MULTIMEDIA VIDEO GAME FORMAT DISTRIBUTED AS DOWNLOADABLE OR DIGITAL MEDIA; INTERACTIVE VIDEO GAME PROGRAMS; VIRTUAL REALITY GAME SOFTWARE; GAME SOFTWARE FOR DOMESTIC USE (U.S. CLS. 21, 23, 26, 36 AND 38).

FIRST USE 2-22-2011; IN COMMERCE 2-22-2011.
ANDREA HACK, EXAMINING ATTORNEY

CLASS 10—MEDICAL APPARATUS

SN 79-089,837. ODYSSEAS INNOTECH GMBH, FED REP GERMANY, FILED 10-19-2010.

ODYSTAR

THE MARK CONSISTS OF STANDARD CHARACTERS WITHOUT CLAIM TO ANY PARTICULAR FONT, STYLE, SIZE, OR COLOR.

PRIORITY DATE OF 6-7-2010 IS CLAIMED.
OWNER OF INTERNATIONAL REGISTRATION 1057928 DATED 10-19-2010, EXPIRES 10-19-2020.

FOR SURGICAL, MEDICAL, DENTAL AND VETERINARY APPARATUS AND INSTRUMENTS, NAMELY, SURGICAL AND MEDICAL APPARATUS AND INSTRUMENTS FOR USE IN GENERAL SURGERY, SURGICAL INSTRUMENTS AND APPARATUS; MEDICAL PUMPS, NAMELY, INFUSION PUMPS FOR DELIVERING MEASURED AMOUNTS OF SOLUTIONS INTO THE TISSUE, NAMELY, A TUMOR, AND THE BLOODSTREAM OVER TIME; MEDICATION PUMPS, NAMELY, BLOOD PUMP SYSTEM FOR USE IN ARTIFICIAL LIVER SUPPORT (U.S. CLS. 26, 39 AND 44).

KRISTINA MORRIS, EXAMINING ATTORNEY

CLASS 10—(Continued).

SN 79-091,629. ORTHOFIX S.R.L., ITALY, FILED 12-17-2010.



PRIORITY DATE OF 9-13-2010 IS CLAIMED.
OWNER OF INTERNATIONAL REGISTRATION 1062523 DATED 12-17-2010, EXPIRES 12-17-2020.

NO CLAIM IS MADE TO THE EXCLUSIVE RIGHT TO USE "ADVANCED LIMB RECONSTRUCTION SYSTEM", APART FROM THE MARK AS SHOWN.

THE MARK CONSISTS OF THE LETTERS "LRS" OVER A QUADRILATERAL CONTAINING THE WORDING, "ADVANCED LIMB RECONSTRUCTION SYSTEM;" THE LETTER "R" IN "LRS" APPEARS TO HAVE THE DESIGN OF A LONG RECTANGLE ON THE LEFT SIDE.

FOR ORTHOPEDIC DEVICES FOR DIAGNOSTIC AND THERAPEUTIC USE FOR EXTERNAL FIXATION COMPRISED OF CLAMPS, ACUTE TEMPLATES, HINGES, COUPLINGS, RAILS, COMPRESSION AND DISTRACTION UNITS, BONE SCREWS AND INSTRUMENTS FOR IMPLANTATION (U.S. CLS. 26, 39 AND 44).

GILBERT SWIFT, EXAMINING ATTORNEY

SN 79-099,482. MEDICREA INTERNATIONAL, FRANCE, FILED 5-23-2011.

LAMINOJAWS

THE MARK CONSISTS OF STANDARD CHARACTERS WITHOUT CLAIM TO ANY PARTICULAR FONT, STYLE, SIZE, OR COLOR.

PRIORITY DATE OF 12-1-2010 IS CLAIMED.
OWNER OF INTERNATIONAL REGISTRATION 1082891 DATED 5-23-2011, EXPIRES 5-23-2021.

FOR PROSTHESES AND OSTEOSYNTHESIS MATERIALS FOR THE SPINAL COLUMN; PROSTHESES FOR INTERVERTEBRAL DISKS; INTERVERTEBRAL IMPLANTS; INSTRUMENTS FOR FITTING PROSTHESES AND OSTEOSYNTHESIS MATERIALS FOR THE SPINAL COLUMN, PROSTHESES FOR SPINAL DISCS AND INTERVERTEBRAL IMPLANTS (U.S. CLS. 26, 39 AND 44).

SUE LAWRENCE, EXAMINING ATTORNEY

CLASS 10—(Continued).

SN 79-102,628. MAQUET GMBH & CO. KG, FED REP GERMANY, FILED 7-8-2011.

YUNO

THE MARK CONSISTS OF STANDARD CHARACTERS WITHOUT CLAIM TO ANY PARTICULAR FONT, STYLE, SIZE, OR COLOR.

PRIORITY DATE OF 1-14-2011 IS CLAIMED.

OWNER OF INTERNATIONAL REGISTRATION 1090881 DATED 7-8-2011, EXPIRES 7-8-2021.

FOR SURGICAL, MEDICAL, DENTAL AND VETERINARY INSTRUMENTS AND APPARATUS; OPERATING TABLES; ACCESSORIES FOR OPERATING TABLES, NAMELY, HEAD RESTS, ARM RESTS, LEG RESTS, BODY SUPPORTS, BODY CUSHIONS, BODY STRAPS AND RESTRAINTS, KNEE CRUTCHES, STIRRUPS, TUBE HOLDERS, INFUSION STANDS, RADIAL SETTING CLAMPS, ANESTHESIA SCREENS, INSTRUMENT TRAYS, TABLE EXTENDERS, SECRETION BASINS, SPLASH GUARD COVERS, PAPER ROLL HOLDERS, SIDE RAILS, PVC PROTECTIVE COVERS, X-RAY CASSETTE HOLDERS; TABLES AND CHAIRS FOR THE EXAMINATION AND TREATMENT OF PATIENTS, INCLUDED IN THIS CLASS; ACCESSORIES FOR TABLES AND CHAIRS FOR THE EXAMINATION AND TREATMENT OF PATIENTS, INCLUDED IN THIS CLASS, NAMELY, HEAD RESTS, ARM RESTS, LEG RESTS, BODY SUPPORTS, BODY CUSHIONS, BODY STRAPS AND RESTRAINTS, KNEE CRUTCHES, STIRRUPS, TUBE HOLDERS, INFUSION STANDS, RADIAL SETTING CLAMPS, ANESTHESIA SCREENS, INSTRUMENT TRAYS, TABLE EXTENDERS, SECRETION BASINS, SPLASH GUARD COVERS, PAPER ROLL HOLDERS, SIDE RAILS, PVC PROTECTIVE COVERS, X-RAY CASSETTE HOLDERS; SUPPORT ARMS FOR SUPPORTING, CARRYING AND ALIGNING BODY PARTS OF PATIENTS; SUPPORT ARMS FOR SUPPORTING, CARRYING AND ALIGNING MEDICAL DEVICES AND MEDICAL ACCESSORIES, NAMELY, HEAD RESTS, ARM RESTS, LEG RESTS, BODY SUPPORTS, BODY CUSHIONS, BODY STRAPS AND RESTRAINTS, KNEE CRUTCHES, STIRRUPS, TUBE HOLDERS, INFUSION STANDS, RADIAL SETTING CLAMPS, ANESTHESIA SCREENS, INSTRUMENT TRAYS, TABLE EXTENDERS, SECRETION BASINS, SPLASH GUARD COVERS, PAPER ROLL HOLDERS, SIDE RAILS, PVC PROTECTIVE COVERS, X-RAY CASSETTE HOLDERS; PREFABRICATED OPERATING THEATERS, NAMELY, A SUPPORT STRUCTURE MADE OF METAL BEAMS, CEILING SERVICE UNITS, REMOVABLE WALLS FOR MODULAR OPERATING ROOMS, CEILING-MOUNTED ROOM LIGHTING, AIR-CONDITIONING, TABLES, MEDICAL FURNITURE, VACUUM EXTRACTION SYSTEM FOR SURGERY, CRITICAL CARE AND HOME-CARE; STERILIZING DEVICES AND DISINFECTING DEVICES; FUNCTIONAL FURNITURE FOR DOCTORS' PRACTICES SPECIFICALLY ADAPTED FOR MEDICAL PURPOSES FOR THE TREATMENT OF PATIENTS AND FUNCTIONAL FURNITURE FOR DOCTORS' PRACTICES SPECIFICALLY ADAPTED FOR THE EXAMINATION OF PATIENTS; PATIENT STRETCHERS (U.S. CLS. 26, 39 AND 44).

JACLYN KIDWELL WALKER, EXAMINING ATTORNEY

CLASS 10—(Continued).

SN 79-106,624. BSN MEDICAL GMBH, FED REP GERMANY, FILED 10-24-2011.

GenuStep

THE MARK CONSISTS OF STANDARD CHARACTERS WITHOUT CLAIM TO ANY PARTICULAR FONT, STYLE, SIZE, OR COLOR.

OWNER OF INTERNATIONAL REGISTRATION 1100338 DATED 10-24-2011, EXPIRES 10-24-2021.

FOR ORTHOPEDIC BANDAGES AND ORTHOSES FOR SUPPORT, STABILISATION AND FIXATION OF JOINTS (U.S. CLS. 26, 39 AND 44).

DANIEL CAPSHAW, EXAMINING ATTORNEY

SN 79-107,023. KONINKLIJKE PHILIPS ELECTRONICS N.V., NETHERLANDS, FILED 11-1-2011.

SPARQ

THE MARK CONSISTS OF STANDARD CHARACTERS WITHOUT CLAIM TO ANY PARTICULAR FONT, STYLE, SIZE, OR COLOR.

PRIORITY DATE OF 5-5-2011 IS CLAIMED.

OWNER OF INTERNATIONAL REGISTRATION 1101273 DATED 11-1-2011, EXPIRES 11-1-2021.

FOR DIAGNOSTIC ULTRASOUND APPARATUS FOR MEDICAL USE (U.S. CLS. 26, 39 AND 44).

KRISTINA MORRIS, EXAMINING ATTORNEY

SN 85-158,132. ZIMMER, INC., WARSAW, IN. FILED 10-21-2010.

BREVIUS

THE MARK CONSISTS OF STANDARD CHARACTERS WITHOUT CLAIM TO ANY PARTICULAR FONT, STYLE, SIZE, OR COLOR.

PRIORITY CLAIMED UNDER SEC. 44(D) ON SWITZERLAND APPLICATION NO. 59533/2010, FILED 9-9-2010.

OWNER OF SWITZERLAND REG. NO. 610558, DATED 1-18-2011, EXPIRES 9-9-2020.

FOR PROSTHESIS AND ENDOPROSTHESIS, NAMELY, HIP STEMS; MEDICAL AND SURGICAL APPARATUS AND INSTRUMENTS, NAMELY, DEVICES USED FOR THE IMPLANTATION OF PROSTHESIS AND PARTS OF PROSTHESIS IN ORTHOPEDIC SURGERY TO POSITION SURGICAL INSTRUMENTS, IMPLANTS AND/OR PATIENT'S LIMBS (U.S. CLS. 26, 39 AND 44).

SUSAN STIGLITZ, EXAMINING ATTORNEY

CLASS 10—(Continued).

SN 85-179,558. HUR USA INC, NORTHBROOK, IL. FILED 11-18-2010.

HUR IBALANCE

THE MARK CONSISTS OF STANDARD CHARACTERS WITHOUT CLAIM TO ANY PARTICULAR FONT, STYLE, SIZE, OR COLOR.

OWNER OF U.S. REG. NO. 2,340,390.
THE WORDING "HUR" HAS NO MEANING IN A FOREIGN LANGUAGE.

FOR PHYSICAL REHABILITATION, PHYSICAL THERAPY AND SPORTS MEDICINE PHYSICAL EXERCISE EQUIPMENT ALL DESIGNED SPECIFICALLY FOR MEDICAL USE FOR BALANCE TESTING, BALANCE TRAINING AND FALL PREVENTION (U.S. CLS. 26, 39 AND 44).

APRIL HESIK, EXAMINING ATTORNEY

CLASS 10—(Continued).

SN 85-240,338. WYNNMED, INC., CHERRYVILLE, NC. FILED 2-11-2011.

WYNNMED

THE MARK CONSISTS OF STANDARD CHARACTERS WITHOUT CLAIM TO ANY PARTICULAR FONT, STYLE, SIZE, OR COLOR.

FOR MEDICAL OR VETERINARY EQUIPMENT, NAMELY, GLOVES FOR MEDICAL PURPOSES, MEDICAL GOWNS, PATIENT EXAMINATION TABLES, SURGICAL MASKS, MEDICAL PATIENT TREATMENT CHAIRS, COOLING APPARATUS USED FOR MEDICAL AND SURGICAL EQUIPMENT USED DURING MEDICAL AND SURGICAL PROCEDURES, INVALID LIFTS, MICROSCOPES FOR OPERATIONS, SCALPELS, AND ELASTIC BANDAGES; HOSPITAL GURNEYS; TROLLEYS FOR MEDICAL EQUIPMENT; MEDICAL EXAMINATION LAMPS; SURGICAL OPERATING LAMPS; VETERINARY OPERATING LAMPS; ANIMAL CAGES FOR HOLDING DOGS AND CATS DURING VETERINARY TREATMENT; ANIMAL TUBS FOR CLEANING DOGS AND CATS DURING VETERINARY TREATMENT (U.S. CLS. 26, 39 AND 44).

WENDY JUN, EXAMINING ATTORNEY

SN 85-205,740. MEDIT CORPORATION, SEOUL, REPUBLIC OF KOREA, FILED 12-26-2010.

IDENTICA

THE MARK CONSISTS OF STANDARD CHARACTERS WITHOUT CLAIM TO ANY PARTICULAR FONT, STYLE, SIZE, OR COLOR.

THE ENGLISH TRANSLATION OF THE WORD "IDENTICA" IN THE MARK IS "IDENTICAL".

FOR MEDICAL AND DENTAL APPARATUS FOR DIMENSIONAL MEASUREMENT, NAMELY, 3D SCANNER FOR HUMAN BODY (U.S. CLS. 26, 39 AND 44).

FIRST USE 3-8-2010; IN COMMERCE 10-29-2010.
EDWARD FENNESSY, EXAMINING ATTORNEY

SN 85-258,730. SPECMED, LLC, ST. ROSE, LA. FILED 3-4-2011.

GammaClip

THE MARK CONSISTS OF STANDARD CHARACTERS WITHOUT CLAIM TO ANY PARTICULAR FONT, STYLE, SIZE, OR COLOR.

FOR RADIOTHERAPY APPARATUS (U.S. CLS. 26, 39 AND 44).

FIRST USE 12-15-2011; IN COMMERCE 12-15-2011.
ROBIN CHOSID, EXAMINING ATTORNEY

CLASS 10—(Continued).

SN 85-281,208. DESIGNS FOR VISION, INC., RONKONKOMA, NY. FILED 3-30-2011.



THE COLOR(S) RED, WHITE, AND BLUE IS/ARE CLAIMED AS A FEATURE OF THE MARK.

THE MARK CONSISTS OF A WHITE HAND OUTLINED IN BLUE HOLDING A BLUE AND WHITE TORCH WITH A RED FLAME WITH THE STYLIZED WORDING "SEE WHAT'S RIGHT ABOUT" IN BLUE AND "MADE IN AMERICA" IN RED LOCATED BELOW THE HAND AND TORCH, A BLUE VERTICAL BAR WITH WHITE STARS ON THE LEFT THEREOF, AND A SOLID RED VERTICAL BAR ON THE RIGHT THEREOF.

FOR HEADLIGHTS, NAMELY, A HIGH INTENSITY HEADLIGHT WITH CONCENTRATED ILLUMINATION USED DURING MEDICAL AND DENTAL PROCEDURES (U.S. CLS. 26, 39 AND 44).

FIRST USE 6-6-1984; IN COMMERCE 6-6-1984.
TASNEEM HUSSAIN, EXAMINING ATTORNEY

SN 85-283,473. DRÄGER MEDICAL GMBH, LÜBECK, FED REP GERMANY, FILED 4-1-2011.

VOLUCOUNT

THE MARK CONSISTS OF STANDARD CHARACTERS WITHOUT CLAIM TO ANY PARTICULAR FONT, STYLE, SIZE, OR COLOR.

OWNER OF ERPN CMNTY TM OFC REG. NO. 004893129, DATED 1-25-2007, EXPIRES 2-10-2016.

FOR TECHNICAL MEDICAL APPARATUS FOR MEASURING AND/OR MONITORING THE FLOW AND/OR CONSUMPTION OF MEDICAL GASES BEING ADMINISTERED TO PATIENTS FOR MEDICAL PURPOSES (U.S. CLS. 26, 39 AND 44).

DAVID ELTON, EXAMINING ATTORNEY

CLASS 10—(Continued).

SN 85-289,854. BAUSCH & LOMB INCORPORATED, ROCHESTER, NY. FILED 4-8-2011.

STABLEGRIP

THE MARK CONSISTS OF STANDARD CHARACTERS WITHOUT CLAIM TO ANY PARTICULAR FONT, STYLE, SIZE, OR COLOR.

FOR MEDICAL APPARATUS, NAMELY, A HANDLE FOR USE WITH SURGICAL INSTRUMENTS (U.S. CLS. 26, 39 AND 44).

ANNE E. GUSTASON, EXAMINING ATTORNEY

SN 85-295,967. BUDDHARAJU, VENKATA, PARK RIDGE, IL. FILED 4-15-2011.

NASAL COMFORT FREEDOM

THE MARK CONSISTS OF STANDARD CHARACTERS WITHOUT CLAIM TO ANY PARTICULAR FONT, STYLE, SIZE, OR COLOR.

NO CLAIM IS MADE TO THE EXCLUSIVE RIGHT TO USE "NASAL COMFORT", APART FROM THE MARK AS SHOWN.

FOR MEDICAL INSTRUMENTS FOR USE IN SUPPLYING AIR, OXYGEN, OR OTHER GASES TO A PATIENT FOR USE WITH VENTILATION EQUIPMENT; NASAL INTERFACE DEVICES FOR USE WITH VENTILATORS, CONTINUOUS POSITIVE AIRWAY PRESSURE (CPAP), AND BILEVEL POSITIVE PRESSURE (BIPAP) MACHINES FOR MEDICAL PURPOSES (U.S. CLS. 26, 39 AND 44).

TRICIA SONNEBORN, EXAMINING ATTORNEY

SN 85-297,328. MEDRAD, INC., INDIANOLA, PA. FILED 4-18-2011.

STELLINITY

THE MARK CONSISTS OF STANDARD CHARACTERS WITHOUT CLAIM TO ANY PARTICULAR FONT, STYLE, SIZE, OR COLOR.

FOR MEDICAL INJECTOR SYSTEM COMPRISING INJECTORS, PUMPS AND SYRINGES FOR DIAGNOSTIC PROCEDURES; CATHETERS, INJECTORS, SYRINGES, DISPOSABLES AND TUBING SETS FOR ADMINISTERING DRUGS OR OTHER FLUID IN CONNECTION WITH A MEDICAL INJECTOR SYSTEM (U.S. CLS. 26, 39 AND 44).

JULIE VEPPUMTHARA, EXAMINING ATTORNEY

CLASS 10—(Continued).

SN 85-302,476. MERIT MEDICAL SYSTEMS, INC., SOUTH JORDAN, UT. FILED 4-22-2011.

Triease

THE MARK CONSISTS OF STANDARD CHARACTERS WITHOUT CLAIM TO ANY PARTICULAR FONT, STYLE, SIZE, OR COLOR.

FOR MEDICAL DEVICES, NAMELY, AN ANTI-REFLUX CONTROL SYSTEM COMPRISING OF A STENT, A DELIVERY DEVICE AND A VALVE (U.S. CLS. 26, 39 AND 44).

Laurie Kaufman, Examining Attorney

SN 85-305,852. MEDRAD, INC., INDIANOLA, PA. FILED 4-27-2011.

PERIO

THE MARK CONSISTS OF STANDARD CHARACTERS WITHOUT CLAIM TO ANY PARTICULAR FONT, STYLE, SIZE, OR COLOR.

FOR MEDICAL INJECTOR SYSTEM COMPRISING INJECTORS, PUMPS AND SYRINGES FOR DIAGNOSTIC PROCEDURES; CATHETERS, INJECTORS, SYRINGES, DISPOSABLES AND TUBING SETS FOR ADMINISTERING DRUGS OR OTHER FLUID IN CONNECTION WITH A MEDICAL INJECTOR SYSTEM (U.S. CLS. 26, 39 AND 44).

Julie Vepumthara, Examining Attorney

SN 85-311,022. MAXTEC, LLC, SALT LAKE CITY, UT. FILED 5-3-2011.

TEC

THE MARK CONSISTS OF STANDARD CHARACTERS WITHOUT CLAIM TO ANY PARTICULAR FONT, STYLE, SIZE, OR COLOR.

FOR OXYGEN SENSORS AND ANALYZERS FOR MEDICAL APPLICATIONS (U.S. CLS. 26, 39 AND 44). FIRST USE 4-1-2011; IN COMMERCE 4-1-2011.

Brendan McCauley, Examining Attorney

CLASS 10—(Continued).

SN 85-315,616. FLIP TECHNOLOGIES LIMITED, DANGAN, COUNTY GALWAY, IRELAND, FILED 5-9-2011.

BESTFLIP

THE MARK CONSISTS OF STANDARD CHARACTERS WITHOUT CLAIM TO ANY PARTICULAR FONT, STYLE, SIZE, OR COLOR.

PRIORITY CLAIMED UNDER SEC. 44(D) ON ERPNCMNTY TM OFC APPLICATION NO. 009723362, FILED 2-9-2011, REG. NO. 009723362, DATED 7-14-2011, EXPIRES 2-9-2021.

OWNER OF U.S. REG. NOS. 3,637,675 AND 3,805,314.

FOR MEDICAL APPARATUS, EQUIPMENT, DEVICES AND INSTRUMENTS FOR USE IN SURGERY; MEDICAL AND SURGICAL APPARATUS, EQUIPMENT, DEVICES AND INSTRUMENTS FOR MONITORING AND/OR MEASURING A PHYSICAL CHARACTERISTIC OF A VESSEL, CAVITY, LUMEN, SPHINCTER OR AN ORGAN OF A HUMAN OR ANIMAL SUBJECT; MEDICAL AND SURGICAL APPARATUS, EQUIPMENT, DEVICES AND INSTRUMENTS FOR TREATING, DILATING AND/OR REMOVING AN OCCLUSION IN A VESSEL, CAVITY, LUMEN OR AN ORGAN OF A HUMAN OR ANIMAL SUBJECT; MEDICAL AND SURGICAL APPARATUS, EQUIPMENT, DEVICES AND INSTRUMENTS FOR USE IN THE DIAGNOSIS OF DISEASES, DAMAGE AND/OR FAILURE OF HOLLOW BODY ORGANS AND SPHINCTERS; MEDICAL AND SURGICAL APPARATUS, EQUIPMENT, DEVICES AND INSTRUMENTS FOR SENSITIVITY TESTING AND BIMODAL SENSITIVITY TESTING OF THE OESOPHAGUS AND OTHER LUMENS AND ORGANS OF A HUMAN OR ANIMAL SUBJECT; TEMPERATURE SENSITIVE TESTING APPARATUS AND INSTRUMENTS FOR MEDICAL USE FOR TESTING THE BODY TEMPERATURE OF HUMANS AND ANIMALS; AND PARTS AND FITTINGS FOR ALL THE AFORESAID GOODS (U.S. CLS. 26, 39 AND 44).

Brian Pino, Examining Attorney

SN 85-324,200. ACACIA, INC., BREA, CA. FILED 5-18-2011.



OWNER OF U.S. REG. NO. 3,797,178.

THE MARK CONSISTS OF THREE CIRCLES TO THE LEFT OF THE WORD "ACACIA".

FOR NEONATAL MEDICAL PRODUCTS, NAMELY, FEEDING SYRINGES, INTRAVENOUS (I.V.) DRUG DELIVERY SETS COMPRISED OF MEDICAL TUBING AND CONNECTORS AND TUBING VALVES; MULTI-ACCESS DRUG DELIVERY SETS COMPRISED OF MEDICAL TUBING AND CONNECTORS AND TUBING VALVES; EXTENSION SETS COMPRISED OF MEDICAL TUBING AND CONNECTORS AND TUBING VALVES; FEEDING TUBES; AND NICU SPECIALTY TUBES (U.S. CLS. 26, 39 AND 44).

Zachary Bello, Examining Attorney

CLASS 10—(Continued).

SN 85-330,060. MEDRAD, INC., INDIANOLA, PA. FILED 5-25-2011.

DELIBERE

THE MARK CONSISTS OF STANDARD CHARACTERS WITHOUT CLAIM TO ANY PARTICULAR FONT, STYLE, SIZE, OR COLOR.

THE ENGLISH TRANSLATION OF "DELIBERE" IS DELIBERATES.

FOR FLUID DELIVERY SYSTEMS FOR ADMINISTERING DIAGNOSTIC OR THERAPEUTIC MEDICAL FLUIDS TO PATIENTS, INCLUDING DISPOSABLE SYRINGES, TUBING AND NEEDLES FOR USE THEREWITH; AND BUFFER REPLACEMENT SYSTEMS FOR REPLACING HIBERNATION OR TRANSPORT MEDICAL BUFFER SOLUTIONS WITH INJECTABLE BUFFER SOLUTIONS FOR DIAGNOSTIC OR THERAPEUTIC MEDICAL PROCEDURES, INCLUDING DISPOSABLE SYRINGES, TUBING, CHECK VALVES AND A MEDICAL WASTE CONTAINER FOR USE THEREWITH (U.S. CLS. 26, 39 AND 44).

JULIE VEPPUMTHARA, EXAMINING ATTORNEY

SN 85-356,563. STERISPINE, NEUVILLE SUR OISE, FRANCE, FILED 6-27-2011.

SteriSpine

THE MARK CONSISTS OF STANDARD CHARACTERS WITHOUT CLAIM TO ANY PARTICULAR FONT, STYLE, SIZE, OR COLOR.

PRIORITY CLAIMED UNDER SEC. 44(D) ON ERP CMNTY TM OFC APPLICATION NO. 009700378, FILED 2-1-2011, REG. NO. 009700378, DATED 7-5-2011, EXPIRES 2-1-2021.

FOR SURGICAL APPARATUS AND INSTRUMENTS MADE TO INSERT SPINALS IMPLANTS COMPOSED OF ARTIFICIAL MATERIAL; DRILL BITS FOR MEDICAL USE, DRILLS FOR MEDICAL USE, SPANNERS AND SCREWDRIVERS FOR MEDICAL USE, SCISSORS FOR MEDICAL USE; ORTHOPAEDIC IMPLANTS MADE OF ARTIFICIAL MATERIAL, NAMELY, SPINAL IMPLANTS; SURGICAL IMPLANTS MADE OF ARTIFICIAL MATERIALS; ARTIFICIAL LIGAMENTS AND TISSUES FOR MEDICAL OR SURGICAL USE (U.S. CLS. 26, 39 AND 44).

TINA BROWN, EXAMINING ATTORNEY

CLASS 10—(Continued).

SN 85-371,025. CONAIR CORPORATION, STAMFORD, CT. FILED 7-14-2011.

Shiatsu + Rest

THE MARK CONSISTS OF STANDARD CHARACTERS WITHOUT CLAIM TO ANY PARTICULAR FONT, STYLE, SIZE, OR COLOR.

NO CLAIM IS MADE TO THE EXCLUSIVE RIGHT TO USE "SHIATSU", APART FROM THE MARK AS SHOWN. FOR MASSAGE APPARATUS (U.S. CLS. 26, 39 AND 44).

YAT SYE, LEE, EXAMINING ATTORNEY

SN 85-371,042. CONAIR CORPORATION, STAMFORD, CT. FILED 7-14-2011.

Body + Rest

THE MARK CONSISTS OF STANDARD CHARACTERS WITHOUT CLAIM TO ANY PARTICULAR FONT, STYLE, SIZE, OR COLOR.

OWNER OF U.S. REG. NO. 3,061,009.

NO CLAIM IS MADE TO THE EXCLUSIVE RIGHT TO USE "BODY", APART FROM THE MARK AS SHOWN.

FOR MASSAGE APPARATUS (U.S. CLS. 26, 39 AND 44).

YAT SYE, LEE, EXAMINING ATTORNEY

SN 85-386,999. KYPHON SARL, NEUCHATEL, SWITZERLAND, FILED 8-2-2011.

InflateFX

THE MARK CONSISTS OF STANDARD CHARACTERS WITHOUT CLAIM TO ANY PARTICULAR FONT, STYLE, SIZE, OR COLOR.

PRIORITY CLAIMED UNDER SEC. 44(D) ON SWITZERLAND APPLICATION NO. 57436/2011, FILED 6-24-2011, REG. NO. 619519, DATED 6-24-2011, EXPIRES 6-24-2021.

FOR MEDICAL AND SURGICAL INSTRUMENTS, NAMELY, BALLOON CATHETERS, TOOLS USED FOR REDUCING BONE FRACTURES, TOOLS USED FOR FILLING VOIDS AND TOOLS USED FOR FILLING BONES (U.S. CLS. 26, 39 AND 44).

MICHAEL LITZAU, EXAMINING ATTORNEY

CLASS 10—(Continued).

SN 85-426,845. GOLD STANDARD DIAGNOSTICS CORP., DAVIS, CA. FILED 9-20-2011.

THUNDERBOLT

THE MARK CONSISTS OF STANDARD CHARACTERS WITHOUT CLAIM TO ANY PARTICULAR FONT, STYLE, SIZE, OR COLOR.

FOR LABORATORY MEDICAL AUTOMATED DIAGNOSTIC DEVICES FOR THE ANALYSIS OF BODILY FLUIDS (U.S. CLS. 26, 39 AND 44).

FIRST USE 10-19-2010; IN COMMERCE 10-19-2010.
WILLIAM JACKSON, EXAMINING ATTORNEY

SN 85-427,624. TOPERA, INC., SCOTTSDALE, AZ. FILED 9-20-2011.

RHYTHMVIEW

THE MARK CONSISTS OF STANDARD CHARACTERS WITHOUT CLAIM TO ANY PARTICULAR FONT, STYLE, SIZE, OR COLOR.

FOR MEDICAL DEVICES FOR ABNORMAL HEART RHYTHM DIAGNOSIS (U.S. CLS. 26, 39 AND 44).

JULIE GUTTADAURO, EXAMINING ATTORNEY

SN 85-427,634. TOPERA, INC., SCOTTSDALE, AZ. FILED 9-20-2011.

Topera

THE MARK CONSISTS OF STANDARD CHARACTERS WITHOUT CLAIM TO ANY PARTICULAR FONT, STYLE, SIZE, OR COLOR.

THE WORD "TOPERA" HAS NO MEANING IN A FOREIGN LANGUAGE.

FOR MEDICAL DEVICES FOR ELECTROPHYSIOLOGY DIAGNOSIS (U.S. CLS. 26, 39 AND 44).

JULIE GUTTADAURO, EXAMINING ATTORNEY

CLASS 10—(Continued).

SN 85-430,505. RALDA A. RYER, WALNUT CREEK, CA. FILED 9-23-2011.

DIGNITY GOWN

THE MARK CONSISTS OF STANDARD CHARACTERS WITHOUT CLAIM TO ANY PARTICULAR FONT, STYLE, SIZE, OR COLOR.

NO CLAIM IS MADE TO THE EXCLUSIVE RIGHT TO USE "GOWN", APART FROM THE MARK AS SHOWN.

FOR MEDICAL GOWNS (U.S. CLS. 26, 39 AND 44).
JOHN DWYER, EXAMINING ATTORNEY

SN 85-431,878. EZEKIEL, MICHAEL, HOLLYWOOD, FL. FILED 9-26-2011.

BIO-HAZARD EC

THE MARK CONSISTS OF STANDARD CHARACTERS WITHOUT CLAIM TO ANY PARTICULAR FONT, STYLE, SIZE, OR COLOR.

NO CLAIM IS MADE TO THE EXCLUSIVE RIGHT TO USE "BIO-HAZARD", APART FROM THE MARK AS SHOWN.

FOR LATEX MEDICAL GLOVES; MEDICAL GLOVES; NITRILE GLOVES FOR MEDICAL USE SOLD TO THE MEDICAL FIELD (U.S. CLS. 26, 39 AND 44).

FIRST USE 9-1-1993; IN COMMERCE 9-1-1993.
DARRYL SPRUILL, EXAMINING ATTORNEY

SN 85-432,123. AUDINA HEARING INSTRUMENTS, INC., LONGWOOD, FL. FILED 9-26-2011.

DYNAMIC EQ

THE MARK CONSISTS OF STANDARD CHARACTERS WITHOUT CLAIM TO ANY PARTICULAR FONT, STYLE, SIZE, OR COLOR.

NO CLAIM IS MADE TO THE EXCLUSIVE RIGHT TO USE "EQ", APART FROM THE MARK AS SHOWN.

FOR HEARING AIDS (U.S. CLS. 26, 39 AND 44).
RAUL CORDOVA, EXAMINING ATTORNEY

CLASS 10—(Continued).

SN 85-438,951. EBI, LLC, PARSIPPANY, NJ. FILED 10-4-2011.

LINEUM

THE MARK CONSISTS OF STANDARD CHARACTERS WITHOUT CLAIM TO ANY PARTICULAR FONT, STYLE, SIZE, OR COLOR.

FOR ORTHOPEDIC APPARATUS, IMPLANTS, AND INSTRUMENTS FOR SURGICAL REPAIR AND/OR FUSION OF THE SPINE (U.S. CLS. 26, 39 AND 44).

KAREN BRACEY, EXAMINING ATTORNEY



SN 85-442,589. BCG MEDICAL, INC., SAN DIEGO, CA. FILED 10-7-2011.

GIAP-sheet

THE MARK CONSISTS OF STANDARD CHARACTERS WITHOUT CLAIM TO ANY PARTICULAR FONT, STYLE, SIZE, OR COLOR.

FOR MEDICAL TABLE SHEETS FOR EXAMINING TABLES AND OPERATING TABLES (U.S. CLS. 26, 39 AND 44).

DOUGLAS LEE, EXAMINING ATTORNEY



SN 85-442,745. BCG MEDICAL, INC., SAN DIEGO, CA. FILED 10-8-2011.

Opt-Sheet

THE MARK CONSISTS OF STANDARD CHARACTERS WITHOUT CLAIM TO ANY PARTICULAR FONT, STYLE, SIZE, OR COLOR.

FOR MEDICAL TABLE SHEETS FOR EXAMINING TABLES AND OPERATING TABLES (U.S. CLS. 26, 39 AND 44).

DOUGLAS LEE, EXAMINING ATTORNEY

CLASS 10—(Continued).

SN 85-446,447. GFA BRANDS, INC., PARAMUS, NJ. FILED 10-13-2011.



NO CLAIM IS MADE TO THE EXCLUSIVE RIGHT TO USE "APPROVED", APART FROM THE MARK AS SHOWN. THE MARK CONSISTS OF THE WORDS "APPROVED BESTLIFE THEBESTLIFE.COM" STACKED IN AN OVAL WITH THREE SMALL LEAF-SHAPES OVER THE LETTER "I" IN "BESTLIFE".

FOR SENSORY LIGHT THERAPY UNIT (U.S. CLS. 26, 39 AND 44).

REBECCA SMITH, EXAMINING ATTORNEY



SN 85-446,537. GALIL MEDICAL LTD., YOKNEAM, ISRAEL, FILED 10-13-2011.

CAUTER-ICE

THE MARK CONSISTS OF STANDARD CHARACTERS WITHOUT CLAIM TO ANY PARTICULAR FONT, STYLE, SIZE, OR COLOR.

FOR CRYOABLATION NEEDLES INCORPORATING A HEATING ELEMENT AT ITS ACTIVE TIP AND USED FOR MINIMALLY INVASIVE CRYOABLATION PROCEDURES EFFECTING CANCEROUS AND BENIGN TISSUES IN THE BODY (U.S. CLS. 26, 39 AND 44).

LINDA MICKLEBURGH, EXAMINING ATTORNEY



SN 85-446,555. SPHERE TECHNOLOGIES, INC., CEDAR-TOWN, GA. FILED 10-13-2011.

SPHERE 810

THE MARK CONSISTS OF STANDARD CHARACTERS WITHOUT CLAIM TO ANY PARTICULAR FONT, STYLE, SIZE, OR COLOR.

FOR LASER FOR HAIR REMOVAL (U.S. CLS. 26, 39 AND 44).

JEFFREY LOOK, EXAMINING ATTORNEY

CLASS 10—(Continued).

SN 85-446,936. MICRO INTERVENTIONAL DEVICES, INC.,
BETHLEHEM, PA. FILED 10-13-2011.



THE MARK CONSISTS OF A STYLIZED DRAWING OF
AN ARCHER.

FOR MEDICAL, SURGICAL IMPLANTS MADE OF
ARTIFICIAL MATERIAL (U.S. CLS. 26, 39 AND 44).
WILLIAM ROSSMAN, EXAMINING ATTORNEY

SN 85-446,942. MICRO INTERVENTIONAL DEVICES, INC.,
BETHLEHEM, PA. FILED 10-13-2011.

PERMASEAL

THE MARK CONSISTS OF STANDARD CHARACTERS
WITHOUT CLAIM TO ANY PARTICULAR FONT, STYLE,
SIZE, OR COLOR.

FOR MEDICAL, SURGICAL IMPLANTS MADE OF
ARTIFICIAL MATERIAL (U.S. CLS. 26, 39 AND 44).
WILLIAM ROSSMAN, EXAMINING ATTORNEY

SN 85-446,951. MICRO INTERVENTIONAL DEVICES, INC.,
BETHLEHEM, PA. FILED 10-13-2011.

**TAKING AIM AT STRUCTURAL
HEART DISEASE**

THE MARK CONSISTS OF STANDARD CHARACTERS
WITHOUT CLAIM TO ANY PARTICULAR FONT, STYLE,
SIZE, OR COLOR.

FOR MEDICAL, SURGICAL IMPLANTS MADE OF
ARTIFICIAL MATERIAL (U.S. CLS. 26, 39 AND 44).
WILLIAM ROSSMAN, EXAMINING ATTORNEY

CLASS 10—(Continued).

SN 85-447,148. JOHNSON, DONALD, SAN DIEGO, CA.
FILED 10-13-2011.

Thera Point

THE MARK CONSISTS OF STANDARD CHARACTERS
WITHOUT CLAIM TO ANY PARTICULAR FONT, STYLE,
SIZE, OR COLOR.

FOR FOCAL PRESSURE THERAPEUTIC DEVICES
FOR TREATING TENDONITIS (U.S. CLS. 26, 39 AND
44).

PRISCILLA MILTON, EXAMINING ATTORNEY

SN 85-447,195. MINDFRAME, INC., IRVINE, CA. FILED 10-
13-2011.

AT THE SPEED OF LIFE

THE MARK CONSISTS OF STANDARD CHARACTERS
WITHOUT CLAIM TO ANY PARTICULAR FONT, STYLE,
SIZE, OR COLOR.

FOR MEDICAL DEVICES, NAMELY, MINIMALLY
INVASIVE NEUROVASCULAR DEVICES FOR THE
TREATMENT OF NEUROLOGICAL CONDITIONS (U.S.
CLS. 26, 39 AND 44).

FIRST USE 10-27-2011; IN COMMERCE 10-27-2011.

FONG HSU, EXAMINING ATTORNEY

SN 85-447,386. ELI LILLY AND COMPANY, INDIANAPOLIS,
IN. FILED 10-14-2011.

SEFFONY

THE MARK CONSISTS OF STANDARD CHARACTERS
WITHOUT CLAIM TO ANY PARTICULAR FONT, STYLE,
SIZE, OR COLOR.

FOR MEDICAL DEVICES FOR SUBCUTANEOUS DIS-
PENSING OF A DRUG, NAMELY, A DRUG DOSING
AND DISPENSING DEVICE, A DISPOSABLE NEEDLE
CASSETTE AND A DISPOSABLE DRUG CARTRIDGE;
ELECTRONIC MEDICAL DEVICES FOR DOSING AND
SUBCUTANEOUS DISPENSING OF A DRUG; NEEDLE
CASSETTES FOR USE WITH DRUG DELIVERY DE-
VICES; MEDICAL DELIVERY DEVICES IN THE FORM
OF A SYRINGE, INJECTOR DEVICE, OR PEN FOR
INJECTING A PHARMACEUTICAL PREPARATION; IN-
SULIN DELIVERY DEVICES; MEDICAL APPARATUS
AND INSTRUMENTS FOR THE ADMINISTRATION OF
INSULIN (U.S. CLS. 26, 39 AND 44).

WILLIAM BRECKENFELD, EXAMINING ATTORNEY

CLASS 10—(Continued).

SN 85-448,092. STARR, LA VOYCE, INGLEWOOD, CA. FILED 10-14-2011.

circumscissor

THE MARK CONSISTS OF STANDARD CHARACTERS WITHOUT CLAIM TO ANY PARTICULAR FONT, STYLE, SIZE, OR COLOR.

FOR MEDICAL DEVICE, NAMELY, A DEVICE USED FOR PERFORMING CIRCUMCISIONS (U.S. CLS. 26, 39 AND 44).

STEVEN R. FINE, EXAMINING ATTORNEY

CLASS 10—(Continued).

SN 85-448,437. CIRCADIANCE LLC, EXPORT, PA. FILED 10-16-2011.

Feather Weight Tube

THE MARK CONSISTS OF STANDARD CHARACTERS WITHOUT CLAIM TO ANY PARTICULAR FONT, STYLE, SIZE, OR COLOR.

NO CLAIM IS MADE TO THE EXCLUSIVE RIGHT TO USE "TUBE", APART FROM THE MARK AS SHOWN.

FOR MEDICAL DEVICES, NAMELY, CONTINUOUS POSITIVE AIRWAY PRESSURE EQUIPMENT FOR THE TREATMENT OF SLEEP APNEA; AIR TUBES FOR MEDICAL RESPIRATORY MASKS (U.S. CLS. 26, 39 AND 44).

EMILY CARLSEN, EXAMINING ATTORNEY

SN 85-448,588. NEUROVENTION, SOUTH DAYTONA, FL. FILED 10-17-2011.

LamiFix

THE MARK CONSISTS OF STANDARD CHARACTERS WITHOUT CLAIM TO ANY PARTICULAR FONT, STYLE, SIZE, OR COLOR.

FOR MEDICAL DEVICES, NAMELY, SPINAL IMPLANTS COMPOSED OF ARTIFICIAL MATERIALS (U.S. CLS. 26, 39 AND 44).

THOMAS MANOR, EXAMINING ATTORNEY

SN 85-448,626. QAL MEDICAL, LLC, MARINETTE, WI. FILED 10-17-2011.

ORTHOAGILITY

THE MARK CONSISTS OF STANDARD CHARACTERS WITHOUT CLAIM TO ANY PARTICULAR FONT, STYLE, SIZE, OR COLOR.

FOR CONTINUOUS PASSIVE MOTION (CPM) MACHINES FOR POSTOPERATIVE AND POST-TRAUMA JOINT REHABILITATION (U.S. CLS. 26, 39 AND 44).

BARBARA GAYNOR, EXAMINING ATTORNEY

SN 85-448,424. BIO VISION TECHNOLOGIES, LLC, CENTENNIAL, CO. FILED 10-16-2011.



OWNER OF U.S. REG. NOS. 3,245,244 AND 3,863,540.

THE MARK CONSISTS OF THE PHRASE "BIO VISION" WITH THE WORD BIO PLACED OVER AND SLIGHTLY TO THE LEFT OF THE WORD "VISION". THE "O" IN "BIO" COMPRISES A STYLIZED EYE WITH A PUPIL/DOT PLACED INSIDE OF THE "O". THE LETTERS "ISION" OF THE WORD "VISION" ARE UNDERLINED. THE PHRASE IS ENCIRCLED BY A STYLIZED ANNULAR LINE. ALONG THE BOTTOM OF THE LINE, THE PHRASE "POWERED BY" IS WRITTEN WITHIN THE WIDTH OF THE LINE.

FOR SURGICAL APPARATUS AND INSTRUMENTS FOR MEDICAL, DENTAL OR VETERINARY USE (U.S. CLS. 26, 39 AND 44).

MICHAEL WEBSTER, EXAMINING ATTORNEY

CLASS 10—(Continued).

SN 85-448,933. ATLANTIC SAFETY PRODUCTS, INC., PITTSFIELD, NH. FILED 10-17-2011.

OUTRAGEOUS ORANGE

THE MARK CONSISTS OF STANDARD CHARACTERS WITHOUT CLAIM TO ANY PARTICULAR FONT, STYLE, SIZE, OR COLOR.

NO CLAIM IS MADE TO THE EXCLUSIVE RIGHT TO USE "ORANGE", APART FROM THE MARK AS SHOWN.

FOR GLOVES FOR MEDICAL USE; GLOVES FOR USE IN HOSPITALS; LATEX MEDICAL GLOVES; SURGICAL GLOVES (U.S. CLS. 26, 39 AND 44).

KATHRYN COWARD, EXAMINING ATTORNEY

CLASS 10—(Continued).

SN 85-449,690. WHET INDUSTRIES, INC., STONY BROOK, NY. FILED 10-18-2011.



THE MARK CONSISTS OF THE STYLIZED WORD "WHET".

FOR ADULT SEXUAL STIMULATION AIDS, NAMELY, VIBRATORS, ARTIFICIAL PENISES, ARTIFICIAL VAGINAS, BENWA BALLS, PENIS ENLARGERS (U.S. CLS. 26, 39 AND 44).

LINDSEY RUBIN, EXAMINING ATTORNEY

SN 85-449,545. JJK INDUSTRIES, LLC, SAINT LOUIS, MO. FILED 10-18-2011.

ThrustVibe

THE MARK CONSISTS OF STANDARD CHARACTERS WITHOUT CLAIM TO ANY PARTICULAR FONT, STYLE, SIZE, OR COLOR.

FOR ADULT SEXUAL STIMULATION AIDS, NAMELY, VIBRATORS AND DILDOS (U.S. CLS. 26, 39 AND 44).

JOHN HWANG, EXAMINING ATTORNEY

SN 85-449,727. CELLAEGIS DEVICES, INC., TORONTO, ONTARIO, CANADA, FILED 10-18-2011.

AUTORIC

THE MARK CONSISTS OF STANDARD CHARACTERS WITHOUT CLAIM TO ANY PARTICULAR FONT, STYLE, SIZE, OR COLOR.

FOR MEDICAL DEVICES FOR INDUCING TRANSIENT ISCHEMIA IN THE BODY OF A MAMMAL TO ENHANCE PHYSICAL PERFORMANCE, TO RENDER TISSUE RESISTANT TO INJURY DURING SUBSEQUENT ISCHEMIC EVENTS, TO TREAT AN ISCHEMIC EVENT, AND TO ENHANCE RECOVERY FROM AN ISCHEMIC EVENT (U.S. CLS. 26, 39 AND 44).

DOMINIC J. FERRAIUOLO, EXAMINING ATTORNEY

SN 85-449,648. CELLAEGIS DEVICES, INC., TORONTO, ONTARIO, CANADA, FILED 10-18-2011.

CELLAEGIS

THE MARK CONSISTS OF STANDARD CHARACTERS WITHOUT CLAIM TO ANY PARTICULAR FONT, STYLE, SIZE, OR COLOR.

FOR MEDICAL DEVICES FOR INDUCING TRANSIENT ISCHEMIA IN THE BODY OF A MAMMAL TO ENHANCE PHYSICAL PERFORMANCE, TO RENDER TISSUE RESISTANT TO INJURY DURING SUBSEQUENT ISCHEMIC EVENTS, TO TREAT AN ISCHEMIC EVENT, AND TO ENHANCE RECOVERY FROM AN ISCHEMIC EVENT (U.S. CLS. 26, 39 AND 44).

DOMINIC J. FERRAIUOLO, EXAMINING ATTORNEY

SN 85-449,855. BIOMERS PTE LTD., SINGAPORE, SINGAPORE, FILED 10-18-2011.

BioMers

THE MARK CONSISTS OF STANDARD CHARACTERS WITHOUT CLAIM TO ANY PARTICULAR FONT, STYLE, SIZE, OR COLOR.

FOR ORTHODONTIC APPLIANCES (U.S. CLS. 26, 39 AND 44).

JAY FLOWERS, EXAMINING ATTORNEY

CLASS 10—(Continued).

SN 85-450,105. C. R. BARD, INC., MURRAY HILL, NJ. FILED 10-18-2011.

SUB2

THE MARK CONSISTS OF STANDARD CHARACTERS WITHOUT CLAIM TO ANY PARTICULAR FONT, STYLE, SIZE, OR COLOR.

FOR MEDICAL DEVICES AND APPARATUS, NAMELY, A BASKET TO REMOVE STONES; AND PARTS AND FITTINGS THEREFOR (U.S. CLS. 26, 39 AND 44).

WILLIAM JACKSON, EXAMINING ATTORNEY

CLASS 10—(Continued).

SN 85-453,459. ENTELLUS MEDICAL, INC., MAPLE GROVE, MN. FILED 10-21-2011.

LIGHT FIBER

THE MARK CONSISTS OF STANDARD CHARACTERS WITHOUT CLAIM TO ANY PARTICULAR FONT, STYLE, SIZE, OR COLOR.

NO CLAIM IS MADE TO THE EXCLUSIVE RIGHT TO USE "LIGHT", APART FROM THE MARK AS SHOWN.

FOR MEDICAL AND SURGICAL INSTRUMENTS FOR USE IN SINUS SURGERY, NAMELY, AN ENDOSCOPIC PROBE (U.S. CLS. 26, 39 AND 44).

FIRST USE 10-17-2011; IN COMMERCE 10-17-2011.

EDWARD NELSON, EXAMINING ATTORNEY

SN 85-450,109. GELB TECHNOLOGIES, LLC, WHITE PLAINS, NY. FILED 10-18-2011.

GELB 4/7

THE MARK CONSISTS OF STANDARD CHARACTERS WITHOUT CLAIM TO ANY PARTICULAR FONT, STYLE, SIZE, OR COLOR.

FOR THERAPEUTIC MOUTHPIECE FOR LIMITING STRAIN AND DISCOMFORT IN THE NECK AND JAW REGION (U.S. CLS. 26, 39 AND 44).

TRACY FLETCHER, EXAMINING ATTORNEY

SN 85-456,666. CAPTIVA SPINE, INC., JUPITER, FL. FILED 10-26-2011.

FuseLox

THE MARK CONSISTS OF STANDARD CHARACTERS WITHOUT CLAIM TO ANY PARTICULAR FONT, STYLE, SIZE, OR COLOR.

FOR INTERBODY FUSION CAGES, NAMELY, A SPINAL IMPLANT COMPRISED OF ARTIFICIAL MATERIALS FOR USE IN SURGICAL SPINAL FUSION PROCEDURES (U.S. CLS. 26, 39 AND 44).

FIRST USE 1-1-2010; IN COMMERCE 7-14-2011.

LAURIE MAYES, EXAMINING ATTORNEY

SN 85-450,155. ST. JUDE MEDICAL, CARDIOLOGY DIVISION, INC., ST. PAUL, MN. FILED 10-18-2011.

PRECEDENT

THE MARK CONSISTS OF STANDARD CHARACTERS WITHOUT CLAIM TO ANY PARTICULAR FONT, STYLE, SIZE, OR COLOR.

FOR MEDICAL DEVICES FOR USE IN RENAL DENERVATION (U.S. CLS. 26, 39 AND 44).

ESTHER A. BORSUK, EXAMINING ATTORNEY

SN 85-456,804. CAPTIVA SPINE, INC., JUPITER, FL. FILED 10-26-2011.

CapLox

THE MARK CONSISTS OF STANDARD CHARACTERS WITHOUT CLAIM TO ANY PARTICULAR FONT, STYLE, SIZE, OR COLOR.

OWNER OF U.S. REG. NO. 3,882,236.

FOR SPINAL IMPLANTS COMPOSED OF ARTIFICIAL MATERIAL FOR USE IN SURGICAL FUSION PROCEDURES (U.S. CLS. 26, 39 AND 44).

FIRST USE 6-20-2009; IN COMMERCE 10-1-2009.

LAURIE MAYES, EXAMINING ATTORNEY

CLASS 10—(Continued).

SN 85-459,955. TYCO HEALTHCARE GROUP LP, NEW HAVEN, CT. FILED 10-31-2011.

DST SERIES

THE MARK CONSISTS OF STANDARD CHARACTERS WITHOUT CLAIM TO ANY PARTICULAR FONT, STYLE, SIZE, OR COLOR.

NO CLAIM IS MADE TO THE EXCLUSIVE RIGHT TO USE "SERIES", APART FROM THE MARK AS SHOWN.

FOR SURGICAL AND MEDICAL APPARATUS AND INSTRUMENTS, NAMELY, WOUND CLOSURE DEVICES, SURGICAL STAPLING INSTRUMENTS, CARTRIDGES CONTAINING STAPLES THEREFOR, SURGICAL STAPLER ANVILS (U.S. CLS. 26, 39 AND 44).

FIRST USE 7-1-2002; IN COMMERCE 7-1-2002.

COURTNEY ALVAREZ, EXAMINING ATTORNEY

CLASS 10—(Continued).

SN 85-477,510. AQUAVIT PHARMACEUTICALS, INC., DBA AQUAVIT PHARMACEUTICALS, INC., NEW YORK, NY. FILED 11-21-2011.

Apollo

THE MARK CONSISTS OF STANDARD CHARACTERS WITHOUT CLAIM TO ANY PARTICULAR FONT, STYLE, SIZE, OR COLOR.

FOR MEDICAL APPARATUS, NAMELY, INFUSION AND INJECTION DEVICES FOR ADMINISTERING DRUGS; MEDICAL DEVICE, NAMELY, PERSONALIZED INJECTION TREATMENT COMPOUNDING DEVICE (U.S. CLS. 26, 39 AND 44).

ANDREW LEASER, EXAMINING ATTORNEY

SN 85-490,638. LRC PRODUCTS LIMITED, SLOUGH, ENGLAND, FILED 12-8-2011.

RING OF BLISS

THE MARK CONSISTS OF STANDARD CHARACTERS WITHOUT CLAIM TO ANY PARTICULAR FONT, STYLE, SIZE, OR COLOR.

FOR CONDOMS; BODY MASSAGE APPARATUS AND INSTRUMENTS; MASSAGE APPARATUS AND INSTRUMENTS FOR INTIMATE AREAS; MASSAGE APPARATUS AND INSTRUMENTS FOR SEXUAL STIMULATION; BATTERY OPERATED PERSONAL MASSAGERS, NAMELY, HAND HELD MASSAGE APPARATUS AND BATTERY-OPERATED MASSAGE APPARATUS; ADULT SEXUAL STIMULATION AND MARITAL AIDS IN THE NATURE OF VIBRATORS; STRUCTURAL PARTS FOR THE AFORESAID GOODS (U.S. CLS. 26, 39 AND 44).

CAROLYN CATALDO, EXAMINING ATTORNEY

SN 85-463,035. LIFEWAVE, INC., SAN DIEGO, CA. FILED 11-2-2011.

ACULIFE

THE MARK CONSISTS OF STANDARD CHARACTERS WITHOUT CLAIM TO ANY PARTICULAR FONT, STYLE, SIZE, OR COLOR.

FOR APPARATUS FOR ACUPRESSURE THERAPY (U.S. CLS. 26, 39 AND 44).

COLLEEN KEARNEY, EXAMINING ATTORNEY

SN 85-473,609. PMC TRADE EXPORT & IMPORT CORP., MIAMI, FL. FILED 11-15-2011.

ALLIVIA

THE MARK CONSISTS OF STANDARD CHARACTERS WITHOUT CLAIM TO ANY PARTICULAR FONT, STYLE, SIZE, OR COLOR.

FOR ELECTRONIC PULSE MASSAGER (U.S. CLS. 26, 39 AND 44).

MARK T. MULLEN, EXAMINING ATTORNEY

SN 85-499,621. KIMBERLY-CLARK WORLDWIDE, INC., NEENAH, WI. FILED 12-20-2011.

SAFESKIN

THE MARK CONSISTS OF STANDARD CHARACTERS WITHOUT CLAIM TO ANY PARTICULAR FONT, STYLE, SIZE, OR COLOR.

OWNER OF U.S. REG. NOS. 1,507,969, 1,921,725 AND 2,033,585.

FOR THERAPEUTIC ICE PACKS (U.S. CLS. 26, 39 AND 44).

TASNEEM HUSSAIN, EXAMINING ATTORNEY

CLASS 10—(Continued).

SN 85-510,732. ASTUTE MEDICAL, INC., SAN DIEGO, CA. FILED 1-6-2012.

Astute 140

THE MARK CONSISTS OF STANDARD CHARACTERS WITHOUT CLAIM TO ANY PARTICULAR FONT, STYLE, SIZE, OR COLOR.

FOR METERS FOR MEDICAL USE, NAMELY, FOR ANALYSIS OF IMMUNOASSAY DEVICES (U.S. CLS. 26, 39 AND 44).

WENDY JUN, EXAMINING ATTORNEY

CLASS 11—(Continued).

SN 79-091,170. MEMSYS GMBH, FED REP GERMANY, FILED 8-30-2010.

memsys

THE MARK CONSISTS OF STANDARD CHARACTERS WITHOUT CLAIM TO ANY PARTICULAR FONT, STYLE, SIZE, OR COLOR.

PRIORITY DATE OF 3-2-2010 IS CLAIMED.

OWNER OF INTERNATIONAL REGISTRATION 1061423 DATED 8-30-2010, EXPIRES 8-30-2020.

FOR INSTALLATIONS FOR SEPARATING SOLVENTS, NAMELY, DISTILLATION APPARATUS, DISTILLATION INSTALLATIONS AND THERMAL SEPARATION INSTALLATIONS FOR THE SEPARATION, BUILD-UP CONCENTRATION AND TREATMENT OF WASTE WATER, DISTILLATION INSTALLATIONS AND THERMAL SEPARATION INSTALLATIONS FOR THE BUILD-UP CONCENTRATION OF ETHANOL, ETHANOL DISTILLATION APPARATUS, DISTILLATION INSTALLATIONS AND THERMAL SEPARATION INSTALLATIONS FOR SEPARATING VOLATILE ACIDS IN THE NATURE OF HYDROCHLORIC ACID, NITRIC ACID OR HYDROFLUORIC ACID FROM OLD CORROSIVE AGENTS, DISTILLATION INSTALLATIONS AND THERMAL SEPARATION INSTALLATIONS FOR STRIPPING AMMONIA FROM ALKALINE SOLUTIONS AND MOBILE MODELS OF ALL AFORESAID INSTALLATIONS AND APPARATUS; AND STRUCTURAL PARTS OF ALL AFORESAID GOODS (U.S. CLS. 13, 21, 23, 31 AND 34).

SUE LAWRENCE, EXAMINING ATTORNEY

CLASS 11—ENVIRONMENTAL CONTROL APPARATUS

SN 76-707,808. NEWCO ENTERPRISES, INC., ST. CHARLES, MO. FILED 5-31-2011.

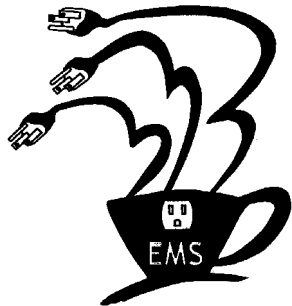

NO CLAIM IS MADE TO THE EXCLUSIVE RIGHT TO USE "EMS", APART FROM THE MARK AS SHOWN.

THE MARK CONSISTS OF A COFFEE CUP CONTAINING A DESIGN OF AN ELECTRICAL OUTLET AND THE LETTERS "EMS". THREE CURVED LINES EMANATE FROM THE TOP OF THE CUP, EACH ENDING IN A DESIGN OF AN ELECTRICAL PLUG.

FOR ELECTRIC COFFEE BREWING MACHINES FEATURING AN ENERGY CONTROLLER, NAMELY, A VOLTAGE AND AMPERAGE REGULATOR AS A COMPONENT PART OF THE MACHINE AND SOLD AS A UNIT (U.S. CLS. 13, 21, 23, 31 AND 34).

SHANNON TWOHIG, EXAMINING ATTORNEY

SN 79-091,667. MEMSYS GMBH, FED REP GERMANY, FILED 8-30-2010.



PRIORITY DATE OF 3-2-2010 IS CLAIMED.

OWNER OF INTERNATIONAL REGISTRATION 1062603 DATED 8-30-2010, EXPIRES 8-30-2020.

THE MARK CONSISTS OF THREE CURVED BANDS.

FOR INSTALLATIONS FOR SEPARATING SOLVENTS, NAMELY, DISTILLATION APPARATUS, DISTILLATION INSTALLATIONS AND THERMAL SEPARATION INSTALLATIONS FOR THE SEPARATION, BUILD-UP CONCENTRATION AND TREATMENT OF WASTE WATER, DISTILLATION INSTALLATIONS AND THERMAL SEPARATION INSTALLATIONS FOR THE BUILD-UP CONCENTRATION OF ETHANOL, ETHANOL DISTILLATION APPARATUS, DISTILLATION INSTALLATIONS AND THERMAL SEPARATION INSTALLATIONS FOR SEPARATING VOLATILE ACIDS IN THE NATURE OF HYDROCHLORIC ACID, NITRIC ACID OR HYDROFLUORIC ACID FROM OLD CORROSIVE AGENTS, DISTILLATION INSTALLATIONS AND THERMAL SEPARATION INSTALLATIONS FOR STRIPPING AMMONIA FROM ALKALINE SOLUTIONS AND MOBILE MODELS OF ALL AFORESAID INSTALLATIONS AND APPARATUS; AND STRUCTURAL PARTS OF ALL AFORESAID GOODS (U.S. CLS. 13, 21, 23, 31 AND 34).

KATHRYN COWARD, EXAMINING ATTORNEY

CLASS 11—(Continued).

SN 79-092,963. LA CORNUE, FRANCE, FILED 12-16-2010.

La Cornue Grande Gourmande

THE MARK CONSISTS OF STANDARD CHARACTERS WITHOUT CLAIM TO ANY PARTICULAR FONT, STYLE, SIZE, OR COLOR.

PRIORITY DATE OF 6-29-2010 IS CLAIMED.

OWNER OF INTERNATIONAL REGISTRATION 1066197 DATED 12-16-2010, EXPIRES 12-16-2020.

OWNER OF U.S. REG. NOS. 1,552,759, 2,396,947 AND 2,720,841.

THE ENGLISH TRANSLATION OF "LA CORNUE GRANDE GOURMANDE" IN THE MARK IS "THE RETORT BIG GOURMAND".

FOR APPARATUS FOR COOKING, NAMELY, GAS AND ELECTRIC STOVES AND OVENS (U.S. CLS. 13, 21, 23, 31 AND 34).

TRACY FLETCHER, EXAMINING ATTORNEY

CLASS 11—(Continued).

SN 79-102,035. COMPUCASE EUROPE GMBH, FED REP GERMANY, FILED 7-28-2011.



PRIORITY DATE OF 7-15-2011 IS CLAIMED.

OWNER OF INTERNATIONAL REGISTRATION 1089314 DATED 7-28-2011, EXPIRES 7-28-2021.

THE MARK CONSISTS OF THE TERM "COUGAR" ON A SHIELD DESIGN WITH A STYLIZED HEAD OF A COUGAR WITH A CROWN, ABOVE THE WORDINGS.

FOR LAMPS, LIGHTING APPARATUS AND INSTALLATIONS, LIGHTS FOR VEHICLES (U.S. CLS. 13, 21, 23, 31 AND 34).

CURTIS FRENCH, EXAMINING ATTORNEY

SN 79-103,491. BIG BANG, FRANCE, FILED 9-6-2011.

NAO

PRIORITY DATE OF 3-18-2011 IS CLAIMED.

OWNER OF INTERNATIONAL REGISTRATION 1093125 DATED 9-6-2011, EXPIRES 9-6-2021.

THE MARK CONSISTS OF THE WORD "NAO" APPEARING IN A STYLIZED FONT.

THE WORDING "NAO" HAS NO MEANING IN A FOREIGN LANGUAGE.

FOR PORTABLE ELECTRIC LAMPS FOR LIGHTING, HEADLAMPS (U.S. CLS. 13, 21, 23, 31 AND 34).

KATHERINE E. HALMEN, EXAMINING ATTORNEY

SN 79-100,822. NANJING XIELI ENVIRONMENTAL PROTECTION TECHNOLOGY CO., LTD., CHINA, FILED 7-26-2011.

yingkun

SN 79-104,766. XIAMEN EASO CO., LTD, CHINA, FILED 10-10-2011.

EASO

OWNER OF INTERNATIONAL REGISTRATION 1086151 DATED 7-26-2011, EXPIRES 7-26-2021.

THE WORDING "YINGKUN" HAS NO MEANING IN A FOREIGN LANGUAGE.

FOR TOILETS, PORTABLE; TOILETS, NAMELY, WATER-CLOSETS; WASH-HAND BASINS BEING PARTS OF SANITARY INSTALLATIONS; TOILET BOWLS; TOILET SEATS; WATER FLUSHING INSTALLATIONS, NAMELY, FLUSH LEVERS; SANITARY FIXTURES, NAMELY, URINALS (U.S. CLS. 13, 21, 23, 31 AND 34).

MATTHEW EINSTEIN, EXAMINING ATTORNEY

OWNER OF INTERNATIONAL REGISTRATION 1096105 DATED 10-10-2011, EXPIRES 10-10-2021.

THE MARK CONSISTS OF FOUR ENGLISH LETTERS "EASO".

FOR BATH INSTALLATIONS, NAMELY, BATHS, BATHTUBS, WHIRLPOOL BATHS AND BATH INSTALLATIONS; SHOWER CUBICLES, NAMELY, SHOWER ENCLOSURES (U.S. CLS. 13, 21, 23, 31 AND 34).

NICHOLAS COLEMAN, EXAMINING ATTORNEY

CLASS 11—(Continued).

SN 85-030,172. FAFCO INCORPORATED, CHICO, CA. FILED 5-4-2010.



OWNER OF U.S. REG. NO. 2,118,362.
THE MARK CONSISTS OF A SQUARE SHAPED SYMBOL COMPRISED OF FOUR LIQUID DROPS AND TO THE RIGHT, THE WORD "REVOLUTION" AND THE WORDS "BY FAFCO" BELOW IT ALIGNED RIGHT.
FOR SOLAR WATER HEAT COLLECTION PANELS (U.S. CLS. 13, 21, 23, 31 AND 34).
JENNIFER VASQUEZ, EXAMINING ATTORNEY

SN 85-100,169. LG ELECTRONICS INC., SEOUL, REPUBLIC OF KOREA, FILED 8-4-2010.

V-net

THE MARK CONSISTS OF STANDARD CHARACTERS WITHOUT CLAIM TO ANY PARTICULAR FONT, STYLE, SIZE, OR COLOR.
OWNER OF REPUBLIC OF KOREA REG. NO. 0766721, DATED 10-28-2008, EXPIRES 10-28-2018.
FOR ELECTRIC REFRIGERATORS; LIGHT-WAVE COOKING OVENS; WINE COOLERS, NAMELY, REFRIGERATED CABINETS CONTAINING RACKS FOR WINE BOTTLES AND STORAGE SHELVES; ELECTRIC COOKING OVENS; ELECTRIC FREEZERS; ELECTRIC CLOTHES DRYERS; GAS RANGES; MICROWAVE OVENS; GAS COOKTOPS; ELECTRIC RANGES FOR HOUSEHOLD PURPOSES; AIR PURIFYING APPARATUS; AIR CONDITIONERS; HOT AIR BLOWERS; HUMIDIFIERS; ELECTRIC DEHUMIDIFIERS FOR HOUSEHOLD PURPOSES; GAS GRILLS; DISH DISINFECTANT APPARATUS FOR INDUSTRIAL PURPOSES; WATER PURIFIERS FOR HOUSEHOLD PURPOSES; ELECTRIC WATER PURIFIERS FOR HOUSEHOLD PURPOSES; WATER IONIZERS; WATER PURIFYING APPARATUS; ELECTRIC FOOTWARMERS; WATER PURIFICATION INSTALLATIONS; WATER FILTERS (U.S. CLS. 13, 21, 23, 31 AND 34).
IRA J. GOODSaid, EXAMINING ATTORNEY

CLASS 11—(Continued).

SN 85-166,565. REGENCY CORPORATION, DBA REGENCY BEAUTY INSTITUTE, BLAINE, MN. FILED 11-1-2010.



OWNER OF U.S. REG. NOS. 2,838,140, 2,949,083 AND 3,439,513.
NO CLAIM IS MADE TO THE EXCLUSIVE RIGHT TO USE "BEAUTY", APART FROM THE MARK AS SHOWN.
THE COLOR(S) COPPER AND WHITE IS/ARE CLAIMED AS A FEATURE OF THE MARK.
THE MARK CONSISTS OF THE WORDS "REGENCY BEAUTY" IN STYLIZED LETTERING, WITH "REGENCY" IN LARGER COPPER LETTERS AGAINST A WHITE BACKGROUND AND PLACED ON TOP OF "BEAUTY" IN SMALLER WHITE LETTERS AGAINST A COPPER BACKGROUND.
FOR HAND-HELD ELECTRIC HAIR DRYERS (U.S. CLS. 13, 21, 23, 31 AND 34).
LAURIE MAYES, EXAMINING ATTORNEY

SN 85-256,452. OPTALITE TECHNOLOGIES LLC, LAS VEGAS, NV. FILED 3-3-2011.

OPTALITE

THE MARK CONSISTS OF STANDARD CHARACTERS WITHOUT CLAIM TO ANY PARTICULAR FONT, STYLE, SIZE, OR COLOR.
FOR HIGHLY EFFICIENT, CUSTOMIZED, LED LIGHTING PRODUCTS, NAMELY, LED LIGHT BULBS AND LED LIGHTING FIXTURES, SPECIFICALLY TO BE USED FOR CONVENTION CENTER LIGHTING, PARKING LOT LIGHTING, AND ARENA LIGHTING, AND TO BE SOLD IN THE INDUSTRIAL, PROFESSIONAL AND RETAIL TRADE CHANNELS (U.S. CLS. 13, 21, 23, 31 AND 34).
JOHN KELLY, EXAMINING ATTORNEY

CLASS 11—(Continued).

SN 85-297,450. ALEXA GROUP INC., TAMPA, FL. FILED 4-18-2011.



THE COLOR(S) RED IS/ARE CLAIMED AS A FEATURE OF THE MARK.

THE MARK CONSISTS OF THE WORD "HILUX" IN RED FONT WITH A RED BORDER.

FOR HEATING AND AIR CONDITIONING EQUIPMENT, NAMELY, HVAC UNITS, ELECTRIC HEATERS FOR RESIDENTIAL AND COMMERCIAL USE, GAS FURNACES, HEAT PUMPS, HYDRONIC FORCED-AIR UNITS, AND AIR-CONDITIONING, AIR COOLING AND VENTILATION APPARATUS AND INSTRUMENTS (U.S. CLS. 13, 21, 23, 31 AND 34).

FIRST USE 11-1-2008; IN COMMERCE 11-1-2008.
ZACHARY BELLO, EXAMINING ATTORNEY

CLASS 11—(Continued).

SN 85-310,880. PROTON ENERGY SYSTEMS, INC., WALLINGFORD, CT. FILED 5-3-2011.



OWNER OF U.S. REG. NOS. 2,204,373, 2,529,000 AND 2,700,436.

NO CLAIM IS MADE TO THE EXCLUSIVE RIGHT TO USE ON SITE, APART FROM THE MARK AS SHOWN.

THE MARK CONSISTS OF THE STYLIZED WORDING "PROTON ONSITE" APPEARING TO THE RIGHT OF A SPHERE DESIGN COMPRISED OF A GROUP OF ROUGHLY CIRCULAR DESIGNS OF VARIOUS SIZES.

FOR ELECTROCHEMICAL GAS GENERATORS; HYDROGEN GENERATORS; NITROGEN-GENERATION EQUIPMENT AND COMPONENTS, NAMELY, NITROGEN GENERATORS AND ASSOCIATED NOZZLES SOLD AS A UNIT; HYDROGEN-GENERATION EQUIPMENT AND COMPONENTS, NAMELY, HYDROGEN GENERATORS, HYDROGEN PURIFIERS, HYDROGEN PURIFICATION MEMBRANES, FUEL PROCESSORS, AND STEAM REFORMERS; CATALYTIC GAS GENERATORS, NAMELY, ZERO-AIR GENERATORS FOR PRODUCING CONTAMINANT-FREE GASES; GAS GENERATORS, NAMELY, HYDROGEN GAS GENERATORS, OXYGEN GAS GENERATORS, NITROGEN GAS GENERATORS, ZERO-AIR GAS GENERATORS (U.S. CLS. 13, 21, 23, 31 AND 34).

FIRST USE 4-18-2011; IN COMMERCE 4-29-2011.
KEVIN CORWIN, EXAMINING ATTORNEY

SN 85-299,224. ALPHALITE INCORPORATED, MOUNT LAUREL, NJ. FILED 4-19-2011.

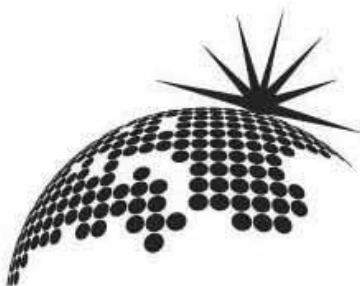

THE MARK CONSISTS OF A STYLIZED DEPICTION OF THE PLANET EARTH UNDERNEATH AND LEFT OF A STYLIZED DEPICTION OF A LIGHT.

FOR LIGHT EMITTING PLASMA LIGHTING FIXTURES (U.S. CLS. 13, 21, 23, 31 AND 34).

FIRST USE 3-25-2011; IN COMMERCE 5-17-2011.
MATTHEW EINSTEIN, EXAMINING ATTORNEY

SN 85-310,900. PROTON ENERGY SYSTEMS, INC., WALLINGFORD, CT. FILED 5-3-2011.

Proton OnSite

THE MARK CONSISTS OF STANDARD CHARACTERS WITHOUT CLAIM TO ANY PARTICULAR FONT, STYLE, SIZE, OR COLOR.

OWNER OF U.S. REG. NOS. 2,204,373, 2,529,000 AND 2,700,436.

NO CLAIM IS MADE TO THE EXCLUSIVE RIGHT TO USE "ONSITE", APART FROM THE MARK AS SHOWN.

FOR ELECTROCHEMICAL GAS GENERATORS; HYDROGEN GENERATORS; NITROGEN-GENERATION EQUIPMENT AND COMPONENTS, NAMELY, NITROGEN GENERATORS AND ASSOCIATED NOZZLES SOLD AS A UNIT; HYDROGEN-GENERATION EQUIPMENT AND COMPONENTS, NAMELY, HYDROGEN GENERATORS, HYDROGEN PURIFIERS, HYDROGEN PURIFICATION MEMBRANES, FUEL PROCESSORS, AND STEAM REFORMERS; CATALYTIC GAS GENERATORS, NAMELY, ZERO-AIR GENERATORS FOR PRODUCING CONTAMINANT-FREE GASES; GAS GENERATORS, NAMELY, HYDROGEN GAS GENERATORS, OXYGEN GAS GENERATORS, NITROGEN GAS GENERATORS, ZERO-AIR GAS GENERATORS (U.S. CLS. 13, 21, 23, 31 AND 34).

FIRST USE 4-18-2011; IN COMMERCE 4-29-2011.
KEVIN CORWIN, EXAMINING ATTORNEY

CLASS 11—(Continued).

SN 85-313,090. SMART CANDLE, LLC, BLOOMINGTON, MN. FILED 5-5-2011.



NO CLAIM IS MADE TO THE EXCLUSIVE RIGHT TO USE "LED TECHNOLOGY", APART FROM THE MARK AS SHOWN.

THE MARK CONSISTS OF THE STYLIZED WORDS "TRUFLAME" ABOVE THE DESIGN OF A FLAME WITH THE WORDS "LED TECHNOLOGY" BELOW, ALL ENCLOSED WITHIN A CIRCLE.

FOR ELECTRONIC CONTROLLED LIGHT THAT SIMULATES THE FLAME OF A WAX CANDLE (U.S. CLS. 13, 21, 23, 31 AND 34).

JESSICA FATHY, EXAMINING ATTORNEY

SN 85-316,558. CAST LIGHTING LLC, HAWTHORNE, NJ. FILED 5-10-2011.

SET-IN-STONE

THE MARK CONSISTS OF STANDARD CHARACTERS WITHOUT CLAIM TO ANY PARTICULAR FONT, STYLE, SIZE, OR COLOR.

FOR ELECTRIC LANDSCAPE LIGHTING FIXTURES (U.S. CLS. 13, 21, 23, 31 AND 34).

BENJAMIN OKEKE, EXAMINING ATTORNEY

SN 85-321,787. FERGUSON ENTERPRISES, INC., NEWPORT NEWS, VA. FILED 5-16-2011.

PROSELECT

THE MARK CONSISTS OF STANDARD CHARACTERS WITHOUT CLAIM TO ANY PARTICULAR FONT, STYLE, SIZE, OR COLOR.

OWNER OF U.S. REG. NOS. 3,065,212, 3,941,024 AND OTHERS.

FOR WATER HEATER PARTS, NAMELY, ANODE RODS, GAS VALVES, RELIEF VALVES AND HEATING ELEMENTS (U.S. CLS. 13, 21, 23, 31 AND 34).

FIRST USE 12-1-2009; IN COMMERCE 12-1-2009.

KIM SAITO, EXAMINING ATTORNEY

CLASS 11—(Continued).

SN 85-332,499. UNIBOND TECHNOLOGY CORP., TAINAN CITY 744, TAIWAN, FILED 5-27-2011.



THE MARK CONSISTS OF THE STYLIZED WORDING "UNIBOND" WHERE A DESIGN OF PARTIAL EXPOSED SUN APPEARS OVER THE LETTER "D".

FOR LAMPS; LIGHT BULBS; LED LAMPS; LED LIGHT BULBS; FLASHLIGHTS; TABLE LAMPS; DESK LAMPS; SUN LAMPS; ART LAMPS; SMALL NIGHT LAMPS; PROJECTOR LAMPS; DECORATIVE LAMPS; WALL LAMPS; FAIRY LIGHTS FOR FESTIVE DECORATION; LIGHTS FOR CHRISTMAS TREES; LIGHTS FOR CEILING FANS; LIGHTS FOR STAGE, NAMELY, ELECTRIC DECORATION LIGHTS; HEADLIGHTS FOR AUTOMOBILES; CHANDELIERS; ELECTRIC STRING LIGHTS FOR DECORATING (U.S. CLS. 13, 21, 23, 31 AND 34).

FIRST USE 4-7-2008; IN COMMERCE 12-15-2010.

SALLY SHIH, EXAMINING ATTORNEY

SN 85-336,944. COVERT, CHAD, POCATELLO, ID. AND COVERT, LINDA, POCATELLO, ID. FILED 6-2-2011.

COLLGEN2

THE MARK CONSISTS OF STANDARD CHARACTERS WITHOUT CLAIM TO ANY PARTICULAR FONT, STYLE, SIZE, OR COLOR.

FOR IONIC COLLOIDAL SILVER GENERATOR FOR PROCESSING WATER BY PRODUCING SILVER IONS AND RADIANT CATALYTIC IONIZATION OXIDATION (U.S. CLS. 13, 21, 23, 31 AND 34).

FIRST USE 1-1-1999; IN COMMERCE 1-1-1999.

CIMMERIAN COLEMAN, EXAMINING ATTORNEY

CLASS 11—(Continued).

SN 85-347,121. TOYOTA TSUSHO AMERICA, INC., NEW YORK, NY. FILED 6-15-2011.

SOLOLUX

THE MARK CONSISTS OF STANDARD CHARACTERS WITHOUT CLAIM TO ANY PARTICULAR FONT, STYLE, SIZE, OR COLOR.

FOR LED REPLACEABLE LIGHTING MODULE, NAMELY, REPLACEABLE LED LIGHT ENGINE (U.S. CLS. 13, 21, 23, 31 AND 34).

SUSAN RICHARDS, EXAMINING ATTORNEY

SN 85-361,497. ENVIRO WATER SOLUTIONS, INC., DBA PELICAN WATER TECHNOLOGIES, DELAND, FL. FILED 7-1-2011.



**Pelican
Water Systems**

OWNER OF U.S. REG. NO. 3,347,210.
NO CLAIM IS MADE TO THE EXCLUSIVE RIGHT TO USE "WATER SYSTEMS", APART FROM THE MARK AS SHOWN.

THE MARK CONSISTS OF LETTER "P" IN SMOOTH FONT WITH A SILHOUETTE OF A PELICAN BIRD WITHIN THE P AND ABOVE THE WORDING "PELICAN WATER SYSTEMS".

FOR FILTERS FOR DRINKING WATER; WATER FILTERING UNITS FOR DOMESTIC USE; WATER FILTERS; WATER FILTRATION AND PURIFICATION UNITS AND REPLACEMENT CARTRIDGES AND FILTERS THEREFOR; WATER SOFTENING UNITS (U.S. CLS. 13, 21, 23, 31 AND 34).

FIRST USE 6-1-2011; IN COMMERCE 6-1-2011.
WILLIAM P. SHANAHAN, EXAMINING ATTORNEY

CLASS 11—(Continued).

SN 85-368,418. SEB, SELONGEY, FRANCE, FILED 7-11-2011.

BREAD OF THE WORLD

THE MARK CONSISTS OF STANDARD CHARACTERS WITHOUT CLAIM TO ANY PARTICULAR FONT, STYLE, SIZE, OR COLOR.

PRIORITY CLAIMED UNDER SEC. 44(D) ON FRANCE APPLICATION NO. 11/3797705, FILED 1-13-2011, REG. NO. 11/3797705, DATED 1-13-2011, EXPIRES 1-13-2021.

FOR ELECTRIC COOKING APPARATUS, NAMELY, ELECTRIC BREAD MACHINES, ELECTRIC OVENS, ELECTRIC TOASTERS (U.S. CLS. 13, 21, 23, 31 AND 34).
SHAILA SETTLES, EXAMINING ATTORNEY

SN 85-401,365. LEO INTERNATIONAL, INC., BROOKLYN, NY. FILED 8-18-2011.



THE COLOR(S) YELLOW, RED, ORANGE AND BLACK IS/ARE CLAIMED AS A FEATURE OF THE MARK.

THE MARK CONSISTS OF A WIDE BLACK-OUTLINED CIRCLE WITH A YELLOW BACKGROUND. THE WORD "EXOTANK" IN RED LETTERS IS PRINTED IN THE CENTER WITH AN IMAGE OF FLAMES IN ORANGE ON TOP OF THE LETTER "T".

FOR HOT WATER HEATING SYSTEM COMPONENTS, NAMELY EXPANSION TANKS (U.S. CLS. 13, 21, 23, 31 AND 34).

FIRST USE 7-16-2009; IN COMMERCE 10-8-2009.
MICHAEL LITZAU, EXAMINING ATTORNEY

SN 85-407,742. CAROTHERS & SON, LTD., EUGENE, OR. FILED 8-25-2011.



THE MARK CONSISTS OF CAPITALIZED LETTERS "CSL" IN METRO STYLE EXTENDED FONT FOLLOWED BY ASTERISK WITH SIX PRONGS CONSISTING OF TWO PARALLEL LINES.

FOR INDUSTRIAL AIR SYSTEMS COMPRISED OF FILTERS, FANS, MECHANICAL PIPING, AIRLOCKS, DUCTWORK, BLOWERS, CONVEYORS, ASPIRATORS, SEPARATORS AND SUPPORTING STRUCTURES FOR THE REMOVAL, CONTROL AND REDUCTION OF PARTICULATES AND OTHER UNDESIRABLE AIRBORNE CONTAMINANTS (U.S. CLS. 13, 21, 23, 31 AND 34).

FIRST USE 2-1-1988; IN COMMERCE 2-1-1988.
BILL DAWE, EXAMINING ATTORNEY

CLASS 11—(Continued).

SN 85-427,159. KAMISORI INC., MARKHAM, ONTARIO, CANADA, FILED 9-20-2011.



NO CLAIM IS MADE TO THE EXCLUSIVE RIGHT TO USE "CAIRO", APART FROM THE MARK AS SHOWN. FOR LIGHTING FIXTURES (U.S. CLS. 13, 21, 23, 31 AND 34).
FIRST USE 1-0-2010; IN COMMERCE 1-0-2010.
CHRISTOPHER LAW, EXAMINING ATTORNEY

SN 85-430,307. AVANTEC, LLC, AKA AVANTEC OVENS, FLORENCE, KY. FILED 9-23-2011.

FLEXDECK

THE MARK CONSISTS OF STANDARD CHARACTERS WITHOUT CLAIM TO ANY PARTICULAR FONT, STYLE, SIZE, OR COLOR.
FOR COMMERCIAL COOKING OVENS (U.S. CLS. 13, 21, 23, 31 AND 34).
ANDREA BUTLER, EXAMINING ATTORNEY

SN 85-433,205. EMSCO, INC., MASSILLON, OH. FILED 9-27-2011.

THE MARK CONSISTS OF THE LETTERS "HYPRCOOL" WITH A WAVY LINE RUNNING THROUGH THE LETTERS.
FOR COOLING TOWERS USED IN LIQUID COOLING SYSTEMS FOR INDUSTRIAL PROCESS EQUIPMENT, INCLUDING INDUCTION FURNACES, THAT REQUIRE REMOVAL OF PROCESS HEAT BY CIRCULATING COOLING LIQUID (U.S. CLS. 13, 21, 23, 31 AND 34).
BRIAN NEVILLE, EXAMINING ATTORNEY

CLASS 11—(Continued).

SN 85-438,705. MY INDOOR GARDEN CORPORATION, SEARSPORT, ME. FILED 10-4-2011.

iSunlight

THE MARK CONSISTS OF STANDARD CHARACTERS WITHOUT CLAIM TO ANY PARTICULAR FONT, STYLE, SIZE, OR COLOR.
FOR LED (LIGHT EMITTING DIODE) LIGHTING FIXTURES; LIGHT EMITTING DIODE (LED) PLANT GROW LIGHT (U.S. CLS. 13, 21, 23, 31 AND 34).
FIRST USE 2-2-2011; IN COMMERCE 2-2-2011.
KAREN K. BUSH, EXAMINING ATTORNEY

SN 85-439,104. STYLE CREST ENTERPRISES, INC., FREMONT, OH. FILED 10-4-2011.

REVOLV

THE MARK CONSISTS OF STANDARD CHARACTERS WITHOUT CLAIM TO ANY PARTICULAR FONT, STYLE, SIZE, OR COLOR.
FOR HEATING AND AIR CONDITIONING UNITS; ACCESSORIES FOR HEATING AND AIR CONDITIONING UNITS, NAMELY, FURNACES, CONDENSORS BEING PARTS OF HVAC EQUIPMENT, LINE SETS BEING PARTS OF HVAC EQUIPMENT AND COILS BEING PARTS OF HVAC EQUIPMENT (U.S. CLS. 13, 21, 23, 31 AND 34).
PATRICIA EVANKO, EXAMINING ATTORNEY

SN 85-439,398. G2 AUTOMATED TECHNOLOGIES, LLC, DALLAS, TX. FILED 10-5-2011.



NO CLAIM IS MADE TO THE EXCLUSIVE RIGHT TO USE "BLANKET WARMING CABINET" AS TO "WARMING CABINETS FOR PATIENT BLANKETS" AND "WARMING CABINET" AS TO "WARMING CABINETS FOR MEDICAL INSTRUMENTS AND CONTAINERS FOR MEDICAL FLUIDS", APART FROM THE MARK AS SHOWN.
THE MARK CONSISTS OF A STAR WITH SIX WAVY STRIPES WITH THE WORD "ACUWARM" BELOW THE STAR AND THE WORDS "BLANKET WARMING CABINET" BELOW "ACUWARM."
FOR WARMING CABINETS FOR MEDICAL INSTRUMENTS, PATIENT BLANKETS AND CONTAINERS FOR MEDICAL FLUIDS (U.S. CLS. 13, 21, 23, 31 AND 34).
MAUREEN DALL, EXAMINING ATTORNEY

CLASS 11—(Continued).

SN 85-442,893. KOSSOW, KENNETH D., HOLLYWOOD, FL. FILED 10-9-2011.



NO CLAIM IS MADE TO THE EXCLUSIVE RIGHT TO USE "TINKLE", APART FROM THE MARK AS SHOWN.

THE COLOR(S) BLACK, YELLOW, BLUE, PINK AND WHITE IS/ARE CLAIMED AS A FEATURE OF THE MARK. THE MARK CONSISTS OF THE STYLIZED WORDS "GOTTA TINKLE" IN BLUE, WITH A YELLOW STAR IN PLACE OF THE DOT IN THE LETTER "I", AND WITH A DRAWING OF A LITTLE GIRL IN BLACK WITH A WHITE PEE DROP ON HER CHEST BETWEEN THE WORDS "GOTTA" AND "TINKLE" AND WITH THE OUTLINE OF THE TOP PORTION OF A HEART IN PINK OVER THE TOP PORTION OF THE LITTLE GIRL'S BODY.

FOR PORTABLE URINALS FOR OUTDOOR ACTIVITIES (U.S. CLS. 13, 21, 23, 31 AND 34). STEVEN R. FINE, EXAMINING ATTORNEY

SN 85-443,691. ADVANCED OPTOELECTRONICS, INC., CAMPBELL, CA. FILED 10-10-2011.



NO CLAIM IS MADE TO THE EXCLUSIVE RIGHT TO USE "LIGHT TECHNOLOGIES", APART FROM THE MARK AS SHOWN.

THE MARK CONSISTS OF THE STYLIZED TEXT "ILLUM LIGHT TECHNOLOGIES" WITH A HORIZONTAL ACCENT MARK OVER THE "U".

FOR LED (LIGHT EMITTING DIODE) LIGHTING FIXTURES; LED (LIGHT EMITTING DIODES) LIGHTING FIXTURES FOR USE IN DISPLAY, COMMERCIAL, INDUSTRIAL, RESIDENTIAL, AND ARCHITECTURAL ACCENT LIGHTING APPLICATIONS; LED LANDSCAPE LIGHTS; LED LIGHT ASSEMBLIES FOR STREET LIGHTS, SIGNS, COMMERCIAL LIGHTING, AUTOMOBILES, BUILDINGS, AND OTHER ARCHITECTURAL USES; LED LIGHT BULBS; LED LIGHT ENGINES; LED LIGHT MACHINES; LED LIGHTING FIXTURES FOR INDOOR AND OUTDOOR LIGHTING APPLICATIONS; LED LIGHTING SYSTEMS, NAMELY, LED MODULES, POWER SUPPLIES, AND WIRING; LED LIGHTS FOR STRINGS, FLOWERS, BRANCHES AND OTHER ORNAMENTAL DECORATIONS; LED LUMINAIRES; LED UNDERWATER LIGHTS; LIGHT EMITTING DIODE (LED) PLANT GROW LIGHT; LUMINAIRES, USING LIGHT EMITTING DIODES (LEDS) AS A LIGHT SOURCE, FOR STREET OR ROADWAY LIGHTING; OPTICAL LENS COVERS THAT IMPROVE LIGHT OUTPUT AND UNIFORMITY AND PROTECT THE LED, SOLD AS A FEATURE OF AN LED LIGHTING SYSTEM; RED LED FLASHLIGHTS FOR ILLUMINATION PURPOSES; TOOLS, COMPONENTS AND SUPPLIES FOR USE IN MAKING SIGNS, NAMELY, FLUORESCENT, HID, LED AND INCANDESCENT BULBS, LAMPS AND FIXTURES (U.S. CLS. 13, 21, 23, 31 AND 34).

FIRST USE 12-1-2010; IN COMMERCE 12-1-2010. ROBERT C. CLARK JR., EXAMINING ATTORNEY

CLASS 11—(Continued).

SN 85-445,565. CARVIN POOL EQUIPMENT INC., HYACINTHE, QUEBEC, CANADA, FILED 10-12-2011.

SANDSTORM

THE MARK CONSISTS OF STANDARD CHARACTERS WITHOUT CLAIM TO ANY PARTICULAR FONT, STYLE, SIZE, OR COLOR.

FOR SWIMMING POOL FILTERS (U.S. CLS. 13, 21, 23, 31 AND 34).

FIRST USE 9-14-1998; IN COMMERCE 9-14-1998. ELLEN BURNS, EXAMINING ATTORNEY

SN 85-446,452. MILLERD, CHET LEE, TEMECULA, CA. FILED 10-13-2011.

ROLLABATH

THE MARK CONSISTS OF STANDARD CHARACTERS WITHOUT CLAIM TO ANY PARTICULAR FONT, STYLE, SIZE, OR COLOR.

FOR BATH TUB JETS; BATH TUBS; BATHS, BATH-TUBS, WHIRLPOOL BATHS AND BATH INSTALLATIONS; BATHTUBS; FILTERS, HEATERS AND PUMPS SOLD IN COMBINATION FOR USE IN BATHS; HOT TUB JETS; HYDROMASSAGE BATH APPARATUS; SIDE-ENTRY BATHS FOR USE BY THE PHYSICALLY HANDICAPPED; WATER JETS FOR USE IN BATHS; WHIRLPOOL BATHS (U.S. CLS. 13, 21, 23, 31 AND 34).

RUSS HERMAN, EXAMINING ATTORNEY

SN 85-446,850. MILLERD, CHET LEE, TEMECULA, CA. FILED 10-13-2011.

PORTABATH

THE MARK CONSISTS OF STANDARD CHARACTERS WITHOUT CLAIM TO ANY PARTICULAR FONT, STYLE, SIZE, OR COLOR.

FOR BATH TUB JETS; BATH TUBS; BATHS, BATH-TUBS, WHIRLPOOL BATHS AND BATH INSTALLATIONS; FILTERS, HEATERS AND PUMPS SOLD IN COMBINATION FOR USE IN BATHS; HOT TUB JETS; HYDROMASSAGE BATH APPARATUS; SIDE-ENTRY BATHS FOR USE BY THE PHYSICALLY HANDICAPPED; WATER JETS FOR USE IN BATHS; WHIRLPOOL BATHS (U.S. CLS. 13, 21, 23, 31 AND 34).

RUSS HERMAN, EXAMINING ATTORNEY

CLASS 11—(Continued).

SN 85-446,910. ELLEN GARDNER, NEW YORK, NY. FILED 10-13-2011.

TOO HOT MAMA

THE MARK CONSISTS OF STANDARD CHARACTERS WITHOUT CLAIM TO ANY PARTICULAR FONT, STYLE, SIZE, OR COLOR.
FOR FOOD AND BEVERAGE COOLING PACKS (U.S. CLS. 13, 21, 23, 31 AND 34).
CARRIE GENOVESE, EXAMINING ATTORNEY

SN 85-446,997. EDBERG, STEPHEN C., SARASOTA, FL. FILED 10-13-2011.

WATER AS NATURE INTENDED IT

THE MARK CONSISTS OF STANDARD CHARACTERS WITHOUT CLAIM TO ANY PARTICULAR FONT, STYLE, SIZE, OR COLOR.
FOR WATER FILTERING APPARATUS (U.S. CLS. 13, 21, 23, 31 AND 34).
KAREN SEVERSON, EXAMINING ATTORNEY

SN 85-447,436. FIELD CONTROLS, LLC, KINSTON, NC. FILED 10-14-2011.

FLEXFILTER

THE MARK CONSISTS OF STANDARD CHARACTERS WITHOUT CLAIM TO ANY PARTICULAR FONT, STYLE, SIZE, OR COLOR.
FOR AIR FILTERS FOR AIR CONDITIONING UNITS AND FOR DOMESTIC USE AND INDUSTRIAL APPLICATIONS (U.S. CLS. 13, 21, 23, 31 AND 34).
FIRST USE 4-8-2011; IN COMMERCE 4-8-2011.
WILLIAM JACKSON, EXAMINING ATTORNEY

CLASS 11—(Continued).

SN 85-447,510. LLOYDS IP HOLDINGS LLC, POMONA, CA. FILED 10-14-2011.

REVOLUTION

THE MARK CONSISTS OF STANDARD CHARACTERS WITHOUT CLAIM TO ANY PARTICULAR FONT, STYLE, SIZE, OR COLOR.
FOR WATER RECREATIONAL APPARATUSES, NAMELY, PORTABLE SPAS IN THE NATURE OF HOT TUBS AND/OR HEATED POOLS (U.S. CLS. 13, 21, 23, 31 AND 34).
KIMBERLY PERRY, EXAMINING ATTORNEY

SN 85-448,064. KLIMAIRE PRODUCTS INC., MIAMI, FL. FILED 10-14-2011.

AquaFinity

THE MARK CONSISTS OF STANDARD CHARACTERS WITHOUT CLAIM TO ANY PARTICULAR FONT, STYLE, SIZE, OR COLOR.
FOR TANKLESS WATER HEATERS (U.S. CLS. 13, 21, 23, 31 AND 34).
WILLIAM BRECKENFELD, EXAMINING ATTORNEY

SN 85-448,850. ZYVITRO COMPANY, MIAMI, FL. FILED 10-17-2011.

XCELVAP

THE MARK CONSISTS OF STANDARD CHARACTERS WITHOUT CLAIM TO ANY PARTICULAR FONT, STYLE, SIZE, OR COLOR.
FOR EVAPORATORS (U.S. CLS. 13, 21, 23, 31 AND 34).
MATTHEW KLINE, EXAMINING ATTORNEY

CLASS 11—(Continued).

SN 85-448,907. COOPER TECHNOLOGIES COMPANY, HOUSTON, TX. FILED 10-17-2011.

GALLEON

THE MARK CONSISTS OF STANDARD CHARACTERS WITHOUT CLAIM TO ANY PARTICULAR FONT, STYLE, SIZE, OR COLOR.

FOR LED LIGHTING FIXTURES FOR INDOOR AND OUTDOOR LIGHTING APPLICATIONS FOR COMMERCIAL, INDUSTRIAL, AND RESIDENTIAL APPLICATION; AREA AND BUILDING LIGHTING FLOOD LIGHTS; OUTDOOR LIGHTING, NAMELY, POLE-MOUNTED LIGHTS (U.S. CLS. 13, 21, 23, 31 AND 34).
LUCY ARANT, EXAMINING ATTORNEY

SN 85-449,047. AIR VENT INC, BUFFALO, NY. FILED 10-17-2011.

Sun Hawk

THE MARK CONSISTS OF STANDARD CHARACTERS WITHOUT CLAIM TO ANY PARTICULAR FONT, STYLE, SIZE, OR COLOR.

NO CLAIM IS MADE TO THE EXCLUSIVE RIGHT TO USE "SUN", APART FROM THE MARK AS SHOWN.

FOR SOLAR POWERED ATTIC FAN (U.S. CLS. 13, 21, 23, 31 AND 34).
LINDA M. KING, EXAMINING ATTORNEY

SN 85-449,468. BETCO CORPORATION, TOLEDO, OH. FILED 10-18-2011.

SMARTSCREEN

THE MARK CONSISTS OF STANDARD CHARACTERS WITHOUT CLAIM TO ANY PARTICULAR FONT, STYLE, SIZE, OR COLOR.

FOR URINAL SCREENS (U.S. CLS. 13, 21, 23, 31 AND 34).
FIRST USE 10-1-2011; IN COMMERCE 10-1-2011.
BRIAN NEVILLE, EXAMINING ATTORNEY

CLASS 11—(Continued).

SN 85-449,493. BETCO CORPORATION, TOLEDO, OH. FILED 10-18-2011.

SMARTVALVE

THE MARK CONSISTS OF STANDARD CHARACTERS WITHOUT CLAIM TO ANY PARTICULAR FONT, STYLE, SIZE, OR COLOR.

FOR PLUMBING FITTINGS, NAMELY, VALVES (U.S. CLS. 13, 21, 23, 31 AND 34).

FIRST USE 10-1-2011; IN COMMERCE 10-1-2011.
BRIAN NEVILLE, EXAMINING ATTORNEY

SN 85-449,743. AS IP HOLDCO, LLC, PISCATAWAY, NJ. FILED 10-18-2011.

BOULEVARD

THE MARK CONSISTS OF STANDARD CHARACTERS WITHOUT CLAIM TO ANY PARTICULAR FONT, STYLE, SIZE, OR COLOR.

FOR SINK PEDESTALS; SINKS; TOILETS (U.S. CLS. 13, 21, 23, 31 AND 34).

FIRST USE 11-1-2002; IN COMMERCE 11-1-2002.
DOMINIC J. FERRAIUOLO, EXAMINING ATTORNEY

SN 85-450,102. ECOFUZE, LLC, JACKSONVILLE, FL. FILED 10-18-2011.



NO CLAIM IS MADE TO THE EXCLUSIVE RIGHT TO USE "ECO" AND "GREEN ENERGY SOLUTIONS", APART FROM THE MARK AS SHOWN.

THE MARK CONSISTS OF THE STYLIZED WORDS "ECO FUZE" ABOVE AN IMAGE OF A GLOBE FEATURING CONTINENTS WITH A LEAF EMERGING FROM THE TOP. CIRCLING THE GLOBE IS A CORD WITH A PLUG ON ONE END AND AN ARROW ON THE OTHER END. THEY DO NOT TOUCH. BELOW THE GLOBE IN THE SHAPE OF A HALF CIRCLE ARE THE WORDS "GREEN ENERGY SOLUTIONS".

FOR LED (LIGHT EMITTING DIODE) LIGHTING FIXTURES; LED LIGHT BULBS (U.S. CLS. 13, 21, 23, 31 AND 34).

FIRST USE 7-0-2011; IN COMMERCE 7-0-2011.
ELLEN B. AWRICH, EXAMINING ATTORNEY

CLASS 11—(Continued).

SN 85-450,992. KOSSOW, KENNETH D., HOLLYWOOD, FL. FILED 10-19-2011.

Gotta Tinkle!

NO CLAIM IS MADE TO THE EXCLUSIVE RIGHT TO USE "TINKLE", APART FROM THE MARK AS SHOWN.

THE COLOR(S) BLUE AND YELLOW IS/ARE CLAIMED AS A FEATURE OF THE MARK.

THE MARK CONSISTS OF THE WORDING "GOTTATINKLE" STYLIZED IN BLUE WITH A YELLOW STAR AS THE DOT ABOVE THE "I" AND AN EXCLAMATION POINT.

FOR PORTABLE URINALS FOR OUTDOOR ACTIVITIES (U.S. CLS. 13, 21, 23, 31 AND 34).

STEVEN R. FINE, EXAMINING ATTORNEY

SN 85-456,432. PORTFOLIO BRAND MANAGEMENT, LLC, LAGUNA NIGUEL, CA. FILED 10-26-2011.

Sun Soaked Creations

THE MARK CONSISTS OF STANDARD CHARACTERS WITHOUT CLAIM TO ANY PARTICULAR FONT, STYLE, SIZE, OR COLOR.

NO CLAIM IS MADE TO THE EXCLUSIVE RIGHT TO USE "CREATIONS", APART FROM THE MARK AS SHOWN.

FOR ELECTRIC LIGHTING FIXTURES; LED (LIGHT EMITTING DIODE) LIGHTING FIXTURES; LIGHTED PARTY-THEMED DECORATIONS, ELECTRIC LIGHT DECORATIVE STRINGS; LIGHTING FIXTURES; SOLAR LIGHT FIXTURES, NAMELY, INDOOR AND OUTDOOR SOLAR POWERED LIGHTING UNITS AND FIXTURES (U.S. CLS. 13, 21, 23, 31 AND 34).

LUCY ARANT, EXAMINING ATTORNEY

SN 85-456,442. PORTFOLIO BRAND MANAGEMENT, LLC, LAGUNA NIGUEL, CA. FILED 10-26-2011.

Solar Artistry

THE MARK CONSISTS OF STANDARD CHARACTERS WITHOUT CLAIM TO ANY PARTICULAR FONT, STYLE, SIZE, OR COLOR.

NO CLAIM IS MADE TO THE EXCLUSIVE RIGHT TO USE "SOLAR", APART FROM THE MARK AS SHOWN.

FOR ELECTRIC LIGHTING FIXTURES; LED (LIGHT EMITTING DIODE) LIGHTING FIXTURES; LIGHTED PARTY-THEMED DECORATIONS, ELECTRIC LIGHT DECORATIVE STRINGS; LIGHTING FIXTURES; SOLAR LIGHT FIXTURES, NAMELY, INDOOR AND OUTDOOR SOLAR POWERED LIGHTING UNITS AND FIXTURES (U.S. CLS. 13, 21, 23, 31 AND 34).

LUCY ARANT, EXAMINING ATTORNEY

CLASS 11—(Continued).

SN 85-458,787. PERRY EQUIPMENT CORPORATION, MINERAL WELLS, TX. FILED 10-28-2011.

XTREAMPHASE

THE MARK CONSISTS OF STANDARD CHARACTERS WITHOUT CLAIM TO ANY PARTICULAR FONT, STYLE, SIZE, OR COLOR.

FOR LIQUID FILTER CARTRIDGES, LIQUID FILTER HOUSINGS, AND COALESCERS, ALL FOR USE IN SEPARATING LIQUIDS FROM LIQUIDS IN THE FIELDS OF OIL AND GAS, REFINERY, PETROCHEMICAL, PULP AND PAPER, POWER GENERATION, AND ELECTRICITY TRANSMISSION, AND FOR USE IN OTHER GENERAL INDUSTRIAL APPLICATIONS FOR THE SEPARATION OF WATER, CHEMICALS, RESINS, SOLVENTS, OR OILS FROM OTHER LIQUIDS (U.S. CLS. 13, 21, 23, 31 AND 34).

DAVID MURRAY, EXAMINING ATTORNEY

SN 85-461,694. PERRY EQUIPMENT CORPORATION, MINERAL WELLS, TX. FILED 11-1-2011.

GOLDXTREAM

THE MARK CONSISTS OF STANDARD CHARACTERS WITHOUT CLAIM TO ANY PARTICULAR FONT, STYLE, SIZE, OR COLOR.

FOR FILTERS FOR USE IN THE OIL AND GAS AND PETROCHEMICAL INDUSTRIES, NAMELY, LIQUID FILTER CARTRIDGES FOR GAS PROCESSING, GAS PRODUCTION, HYDROCARBON REFINING, WASTEWATER TREATMENT, AND RAW WATER FEEDS (U.S. CLS. 13, 21, 23, 31 AND 34).

DAVID MURRAY, EXAMINING ATTORNEY

SN 85-464,304. WHIRLPOOL PROPERTIES, INC., ST. JOSEPH, MI. FILED 11-4-2011.

ACCUFRESH

THE MARK CONSISTS OF STANDARD CHARACTERS WITHOUT CLAIM TO ANY PARTICULAR FONT, STYLE, SIZE, OR COLOR.

FOR REFRIGERATOR TEMPERATURE MANAGEMENT SYSTEM COMPRISING AUTOMATIC TEMPERATURE REGULATORS, TEMPERATURE SENSORS, AND THERMOSTATS, SOLD AS A COMPONENT PART OF REFRIGERATORS (U.S. CLS. 13, 21, 23, 31 AND 34).

ELLEN B. AWRICH, EXAMINING ATTORNEY

CLASS 11—(Continued).

SN 85-492,721. FLEET WHOLESALE SUPPLY CO., INC., APPLETON, WI. FILED 12-12-2011.

IRON BRIGADE

THE MARK CONSISTS OF STANDARD CHARACTERS WITHOUT CLAIM TO ANY PARTICULAR FONT, STYLE, SIZE, OR COLOR.

OWNER OF U.S. REG. NOS. 800,296 AND 2,707,242. FOR WATER TREATMENT EQUIPMENT, NAMELY, WATER SOFTENERS (U.S. CLS. 13, 21, 23, 31 AND 34). MARY ROSSMAN, EXAMINING ATTORNEY

SN 85-501,514. LLOYDS IP HOLDINGS, LLC, POMONA, CA. FILED 12-21-2011.

HERCULES

THE MARK CONSISTS OF STANDARD CHARACTERS WITHOUT CLAIM TO ANY PARTICULAR FONT, STYLE, SIZE, OR COLOR.

FOR SPA SURROUNDS (U.S. CLS. 13, 21, 23, 31 AND 34). TINA MAI, EXAMINING ATTORNEY

SN 85-509,188. FIELD CONTROLS, LLC, KINSTON, NC. FILED 1-5-2012.

FlexFilter

FOR AIR FILTERS FOR AIR CONDITIONING UNITS AND FOR DOMESTIC USE AND INDUSTRIAL APPLICATIONS (U.S. CLS. 13, 21, 23, 31 AND 34). FIRST USE 4-8-2011; IN COMMERCE 4-8-2011. WILLIAM JACKSON, EXAMINING ATTORNEY

CLASS 11—(Continued).

SN 85-520,283. COOPER TECHNOLOGIES COMPANY, HOUSTON, TX. FILED 1-19-2012.

QUADCAST

THE MARK CONSISTS OF STANDARD CHARACTERS WITHOUT CLAIM TO ANY PARTICULAR FONT, STYLE, SIZE, OR COLOR.

FOR ELECTRIC LIGHTING FIXTURES; LED LIGHTING FIXTURES FOR INDOOR AND OUTDOOR LIGHTING APPLICATIONS; LIGHTING FIXTURES FOR USE IN PARKING DECKS AND GARAGES; LIGHTING FIXTURES FOR USE IN PARKING LOTS AND WALKWAYS; LIGHT FIXTURES FOR ILLUMINATING STAIRS, DOORS AND OTHER PORTIONS OF BUILDINGS; LIGHTING FIXTURES FOR CANOPIES AND TUNNELS; LIGHTING FIXTURES FOR CEILINGS; LIGHTING FIXTURES WITH PENDANT MOUNTING; LIGHTING FIXTURES WITH MOTION DETECTION ; LIGHTING FIXTURES WITH OCCUPANCY DETECTION (U.S. CLS. 13, 21, 23, 31 AND 34).

LUCY ARANT, EXAMINING ATTORNEY

CLASS 12—VEHICLES

SN 76-454,636. EMBRAER - EMPRESA BRASILEIRA DE AERONAUTICA S.A., SAN JOSE DOS CAMPOS, SP 12225-901, BRAZIL, FILED 9-24-2002.

EMBRAER 175

PRIORITY CLAIMED UNDER SEC. 44(D) ON BRAZIL APPLICATION NO. 824617657, FILED 6-20-2002.

OWNER OF U.S. REG. NO. 1,143,286. FOR AIRPLANES (U.S. CLS. 19, 21, 23, 31, 35 AND 44). FIRST USE 7-17-2007; IN COMMERCE 7-17-2007. KATHERINE CONNOLLY, EXAMINING ATTORNEY

SN 76-707,242. JOHN E. MURRAY, POMPANO BEACH, FL. FILED 4-13-2011.

ALASKAN

THE MARK CONSISTS OF STANDARD CHARACTERS WITHOUT CLAIM TO ANY PARTICULAR FONT, STYLE, SIZE, OR COLOR.

FOR LUXURY YACHTS HAVING LENGTHS UP TO 60 FEET, 85 FEET AND LONGER, NORMALLY OPERATED BY A CAPTAIN AND CREW, AND RETAILING IN THE PRICE RANGE OF ONE MILLION U.S. DOLLARS AND HIGHER, FOR THE WEALTHY, AFFLUENT AND SOPHISTICATED CUSTOMER, SOLD AT BOAT SHOWS AND MARINAS, BY YACHT BUILDERS AND BROKERS AND ADVERTISED PRIMARILY THROUGH HIGH END YACHTING PUBLICATIONS (U.S. CLS. 19, 21, 23, 31, 35 AND 44).

FIRST USE 10-8-2002; IN COMMERCE 10-8-2002. MARILYN IZZI, EXAMINING ATTORNEY

CLASS 12—(Continued).

SN 76-709,533. THUNDERHEADER RACING PRODUCTS, INC., SAN PABLO, CA. FILED 10-26-2011.

THUNDERHEADER

THE MARK CONSISTS OF STANDARD CHARACTERS WITHOUT CLAIM TO ANY PARTICULAR FONT, STYLE, SIZE, OR COLOR.

OWNER OF U.S. REG. NO. 1,588,739.

FOR MOTORCYCLE STRUCTURAL PARTS, NAMELY, MOTORCYCLE EXHAUST MUFFLERS AND HEADERS EMPLOYED IN MOTORCYCLE EXHAUST SYSTEM (U.S. CLS. 19, 21, 23, 31, 35 AND 44).

FIRST USE 3-19-1989; IN COMMERCE 3-19-1989.
FRANK LATTUCA, EXAMINING ATTORNEY

CLASS 12—(Continued).

SN 85-130,928. WHITING DOOR MANUFACTURING CORP., AKRON, NY. FILED 9-16-2010.

SHIELDSERIES

THE MARK CONSISTS OF STANDARD CHARACTERS WITHOUT CLAIM TO ANY PARTICULAR FONT, STYLE, SIZE, OR COLOR.

FOR TRUCK AND TRAILER DOORS AND STRUCTURAL PARTS THEREOF (U.S. CLS. 19, 21, 23, 31, 35 AND 44).

JACQUELINE A. LAVINE, EXAMINING ATTORNEY

SN 79-096,212. BICICLETAS DE ÁLAVA, S.L., SPAIN, FILED 4-7-2011.

LYNX

THE MARK CONSISTS OF STANDARD CHARACTERS WITHOUT CLAIM TO ANY PARTICULAR FONT, STYLE, SIZE, OR COLOR.

PRIORITY DATE OF 4-1-2011 IS CLAIMED.

OWNER OF INTERNATIONAL REGISTRATION 1074033 DATED 4-7-2011, EXPIRES 4-7-2021.

FOR FULL SUSPENSION FRAMES FOR MOUNTAIN BIKES (U.S. CLS. 19, 21, 23, 31, 35 AND 44).

JULIE VEPPUMTHARA, EXAMINING ATTORNEY

SN 85-165,783. JET STAR CORPORATION, NEW YORK, NY. FILED 11-1-2010.

SN 79-099,328. PIRELLI TYRE S.P.A., ITALY, FILED 5-17-2011.

P1

THE MARK CONSISTS OF STANDARD CHARACTERS WITHOUT CLAIM TO ANY PARTICULAR FONT, STYLE, SIZE, OR COLOR.

PRIORITY DATE OF 4-11-2011 IS CLAIMED.

OWNER OF INTERNATIONAL REGISTRATION 1082468 DATED 5-17-2011, EXPIRES 5-17-2021.

FOR TIRES; SOLID, SEMI-PNEUMATIC AND PNEUMATIC TIRES AND RIMS FOR VEHICLE WHEELS OF ALL KINDS; WHEELS FOR VEHICLES OF ALL KINDS; INNER TUBES; WHEEL RIMS; STRUCTURAL PARTS FOR VEHICLE WHEELS OF ALL KINDS (U.S. CLS. 19, 21, 23, 31, 35 AND 44).

KRISTINA MORRIS, EXAMINING ATTORNEY



The logo for Jet Star features the words "Jet Star" in a stylized, italicized font. The "J" is large and prominent. A star is positioned above the "a" in "Star", and a swoosh underline extends from the "J" under the "a".

NO CLAIM IS MADE TO THE EXCLUSIVE RIGHT TO USE "JET", APART FROM THE MARK AS SHOWN.

THE MARK CONSISTS OF THE STYLIZED WORDING "JET STAR" PARTIALLY OVERLAYING A STAR WITH A TAIL IN THE FORM OF A SWOOSH DESIGN.

FOR PERSONAL JET PACK FOR INDIVIDUAL FLIGHT (U.S. CLS. 19, 21, 23, 31, 35 AND 44).

PRISCILLA MILTON, EXAMINING ATTORNEY

CLASS 12—(Continued).

SN 85-222,759. 578539 B.C. LTD., TA CANADIAN MAICO, VICTORIA, B. C., CANADA, FILED 1-21-2011.



THE COLOR(S) BLACK, WHITE, RED, GOLD IS/ARE CLAIMED AS A FEATURE OF THE MARK.

THE MARK CONSISTS OF A STYLIZED LETTER "M" IN BLACK AND WHITE WITH GOLD COLORED WINGS EMANATING FROM EITHER SIDE, THE WINGS HAVE BLACK HORIZONTAL LINES ON THEM AND ARE OUTLINED IN BLACK. THE NAME "MAICO" IS IN GOLD LETTERS ON A RED BACKGROUND ON THE TOP CENTER OF THE STYLIZED LETTER "M" AND WINGS. THERE IS A SEMI BADGE SHAPE AROUND THE PERIMETER WITH GOLD AND BLACK STRIPES

FOR MOTORCYCLES FOR MOTOCROSS (U.S. CLS. 19, 21, 23, 31, 35 AND 44).

FIRST USE 12-1-2002; IN COMMERCE 12-1-2002.
MICHELLE DUBOIS, EXAMINING ATTORNEY

SN 85-227,480. FORMULA ONE LICENSING BV, ROTTERDAM, NETHERLANDS, FILED 1-27-2011.

FORMULA 1

THE MARK CONSISTS OF STANDARD CHARACTERS WITHOUT CLAIM TO ANY PARTICULAR FONT, STYLE, SIZE, OR COLOR.

OWNER OF BENELUX REG. NO. 0891900, DATED 6-29-2010, EXPIRES 6-29-2020.

OWNER OF U.S. REG. NOS. 2,586,148, 3,587,198 AND OTHERS.

FOR VEHICLES, NAMELY, AUTOMOBILES; APPARATUS FOR LOCOMOTION BY LAND, NAMELY, AUTOMOBILES; AIRPLANES; AIRBAGS FOR VEHICLES; AUTOMOBILE ENGINES; AUTOMOBILE TIRES; AUTOMOBILES; BABY CARRIAGES; BICYCLES; BOATS; MOTOR BUSES; LUGGAGE CARRIERS FOR VEHICLES; CARS; DIRIGIBLE BALLOONS FOR ADVERTISING USE; ELECTRIC VEHICLES, NAMELY, AUTOMOBILES; VEHICLE GEAR STICK COVERS; GLARE SHIELDS FOR MOTOR VEHICLES; HUB CAPS; LICENSE PLATE FRAMES; LORRIES; MOTOR CAR ACCESSORIES NOT INCLUDED IN OTHER CLASSES, NAMELY, LUGGAGE CARRIERS FOR VEHICLES, REARVIEW MIRRORS, WINDSCREEN WIPERS, STEERING WHEEL COVERS; MOTOR CARS; MOTOR COACHES; MOTOR HOMES; MOTORCYCLES, SCOOTERS; PUSHCHAIRS; REFRIGERATED VEHICLES; SAFETY BELTS FOR VEHICLE SEATS; SAFETY SEATS FOR CHILDREN, FOR VEHICLES; SEAT COVERS FOR VEHICLES; SPORTS CARS; STROLLERS FOR CHILDREN; TRAILERS; TRUCKS; NON-SKID CHAINS FOR VEHICLE TIRES; INNER TUBES FOR VEHICLE WHEELS; VANS; FITTED COVERS FOR VEHICLES; VEHICLES FOR LOCOMOTION BY LAND, NAMELY, AUTOMOBILES (U.S. CLS. 19, 21, 23, 31, 35 AND 44).

PAUL MORENO, EXAMINING ATTORNEY

CLASS 12—(Continued).

SN 85-230,061. ZIKE, LLC, GREENVILLE, SC. FILED 1-31-2011.

ZikeBike

THE MARK CONSISTS OF STANDARD CHARACTERS WITHOUT CLAIM TO ANY PARTICULAR FONT, STYLE, SIZE, OR COLOR.

OWNER OF U.S. REG. NOS. 3,898,239 AND 4,055,121.

SEC. 2(F) AS TO "ZIKE".

FOR NON-MOTORIZED SCOOTERS (U.S. CLS. 19, 21, 23, 31, 35 AND 44).

CURTIS FRENCH, EXAMINING ATTORNEY

SN 85-278,812. JOINT RESOURCES, INC., GLENDALE HEIGHTS, IL. FILED 3-28-2011.



THE COLOR(S) BLACK, RED AND WHITE IS/ARE CLAIMED AS A FEATURE OF THE MARK.

THE MARK CONSISTS OF THE STYLIZED WORDS "I TOW" IN BLACK WITH A RED DOT IN THE LETTER "I" ENCIRCLED IN A BLACK CIRCLE, ALL OF THE ABOVE ON A WHITE BACKGROUND.

FOR AUTOMOTIVE TOW HITCHES AND ACCESSORIES, NAMELY, BALL MOUNTS, TRAILER COUPLINGS, HITCH PINS FOR TRAILER HITCHES AND METAL LOCKING DEVICES FOR TRAILER HITCH COUPLERS; TRAILERS AND PARTS THEREFOR (U.S. CLS. 19, 21, 23, 31, 35 AND 44).

DAVID TAYLOR, EXAMINING ATTORNEY

SN 85-297,760. THOR TECH, INC., JACKSON CENTER, OH. FILED 4-18-2011.

EZ-STREET

THE MARK CONSISTS OF STANDARD CHARACTERS WITHOUT CLAIM TO ANY PARTICULAR FONT, STYLE, SIZE, OR COLOR.

FOR BUSES (U.S. CLS. 19, 21, 23, 31, 35 AND 44).

CHRISTINE COOPER, EXAMINING ATTORNEY

CLASS 12—(Continued).

SN 85-298,974. CORRECT CRAFT IP HOLDINGS, LLC, ORLANDO, FL. FILED 4-19-2011.

SUPER AIR NAUTIQUE

THE MARK CONSISTS OF STANDARD CHARACTERS WITHOUT CLAIM TO ANY PARTICULAR FONT, STYLE, SIZE, OR COLOR.

OWNER OF U.S. REG. NOS. 2,198,994, 3,566,255 AND OTHERS.

NO CLAIM IS MADE TO THE EXCLUSIVE RIGHT TO USE "SUPER", APART FROM THE MARK AS SHOWN.

THE ENGLISH TRANSLATION OF "NAUTIQUE" IN THE MARK IS "NAUTICAL".

FOR BOATS (U.S. CLS. 19, 21, 23, 31, 35 AND 44).

FIRST USE 8-1-1998; IN COMMERCE 8-1-1998.

ERIN FALK, EXAMINING ATTORNEY

SN 85-300,335. ATSUMI CAR EQUIPMENT, INC., WYTHEVILLE, VA. FILED 4-20-2011.

ATSUMI

THE MARK CONSISTS OF STANDARD CHARACTERS WITHOUT CLAIM TO ANY PARTICULAR FONT, STYLE, SIZE, OR COLOR.

THE WORDING "ATSUMI" HAS NO MEANING IN A FOREIGN LANGUAGE.

FOR COMPONENTS FOR LAND VEHICLES, NAMELY, WHEEL HUB OUTER RINGS AND SPINDLES (U.S. CLS. 19, 21, 23, 31, 35 AND 44).

COURTNEY ALVAREZ, EXAMINING ATTORNEY

SN 85-300,619. MURKOWSKI, JAMES R., ARLINGTON HEIGHTS, IL. FILED 4-20-2011.

SLIMSERT

THE MARK CONSISTS OF STANDARD CHARACTERS WITHOUT CLAIM TO ANY PARTICULAR FONT, STYLE, SIZE, OR COLOR.

FOR DRINK HOLDERS FOR USE IN VEHICLES, AND ADAPTORS FOR ACCOMMODATING DIFFERENT SIZE DRINKS IN A STANDARD VEHICLE DRINK HOLDER (U.S. CLS. 19, 21, 23, 31, 35 AND 44).

SHAILA SETTLES, EXAMINING ATTORNEY

CLASS 12—(Continued).

SN 85-303,154. ABDUL RAHMAN, IZZAT BIN, PHILADELPHIA, PA. FILED 4-25-2011.

Kayuh Bicycles

THE MARK CONSISTS OF STANDARD CHARACTERS WITHOUT CLAIM TO ANY PARTICULAR FONT, STYLE, SIZE, OR COLOR.

NO CLAIM IS MADE TO THE EXCLUSIVE RIGHT TO USE "BICYCLES", APART FROM THE MARK AS SHOWN.

THE ENGLISH TRANSLATION OF THE WORD "KAYUH" IN THE MARK IS PADDLE.

FOR RACING BICYCLES (U.S. CLS. 19, 21, 23, 31, 35 AND 44).

TAMARA FRAZIER, EXAMINING ATTORNEY

SN 85-309,234. FLEXIONE A/S, 6650 BRØRUP, DENMARK, FILED 4-30-2011.

WHEELAX

THE MARK CONSISTS OF STANDARD CHARACTERS WITHOUT CLAIM TO ANY PARTICULAR FONT, STYLE, SIZE, OR COLOR.

PRIORITY CLAIMED UNDER SEC. 44(D) ON DENMARK APPLICATION NO. VA201100937, FILED 3-29-2011, REG. NO. VR201101250, DATED 5-18-2011, EXPIRES 5-18-2021.

FOR TROLLEYS; WHEELING DEVICES IN THE NATURE OF DOLLIES, CARTS AND WHEEL BARROWS FOR TRANSPORTING AND MOVING TIRES, RIMS AND WHEELS (U.S. CLS. 19, 21, 23, 31, 35 AND 44).

B. PARADEWELAI, EXAMINING ATTORNEY

SN 85-392,167. ALZOR, INC., WADSWORTH, OH. FILED 8-8-2011.

ALZOR

THE MARK CONSISTS OF STANDARD CHARACTERS WITHOUT CLAIM TO ANY PARTICULAR FONT, STYLE, SIZE, OR COLOR.

THE WORDING "ALZOR" HAS NO MEANING IN A FOREIGN LANGUAGE.

FOR VEHICLE WHEEL RIMS (U.S. CLS. 19, 21, 23, 31, 35 AND 44).

FIRST USE 7-20-2011; IN COMMERCE 7-20-2011.

THOMAS MANOR, EXAMINING ATTORNEY

CLASS 12—(Continued).

SN 85-396,621. GF HEALTH PRODUCTS, INC., ATLANTA, GA. FILED 8-12-2011.

Advantage

THE MARK CONSISTS OF STANDARD CHARACTERS WITHOUT CLAIM TO ANY PARTICULAR FONT, STYLE, SIZE, OR COLOR.

OWNER OF U.S. REG. NO. 1,609,002.

FOR HANDRIMS AND PUSHRIMS FOR WHEELCHAIRS; MOTORIZED, ELECTRIC-POWERED, SELF-PROPELLED, SELF-BALANCING, WHEELED PERSONAL MOBILITY TRANSPORTATION DEVICE; MULTIPLE-POCKETED CARRIER FOR PERSONAL ITEMS SPECIALLY ADAPTED FOR ATTACHMENT TO WHEELCHAIRS; VISCOUS GEL POLYMER SOLD AS A COMPONENT OF FINISHED CUSTOM CUSHIONED WHEEL CHAIR SEATS AND BACK CUSHIONS; WHEEL CHAIRS; WHEELCHAIR CUSHIONS; WHEELCHAIR PADS; WHEELCHAIRS (U.S. CLS. 19, 21, 23, 31, 35 AND 44).

FIRST USE 6-1-1988; IN COMMERCE 6-1-1988.
BENJAMIN OKEKE, EXAMINING ATTORNEY

SN 85-402,384. ALLARD, LLOYD, MONMOUTH, UNITED KINGDOM, FILED 8-19-2011.

ALLARD

THE MARK CONSISTS OF STANDARD CHARACTERS WITHOUT CLAIM TO ANY PARTICULAR FONT, STYLE, SIZE, OR COLOR.

SEC. 2(F).

FOR CARS; RACING CARS; SPORTS CARS; MOTOR CAR SEATS; AUTOMOBILE CHASSIS; BODY AND DOOR PANELS FOR AUTOMOBILES; FUEL LINES FOR VEHICLES; AUTOMOTIVE STRUCTURAL PARTS, NAMELY, TANKS FOR FUEL STORAGE, COOLANT STORAGE, OIL STORAGE, AND/OR WATER STORAGE; AUTOMOBILE STRUCTURAL PARTS FOR RACING PURPOSES, NAMELY, FUEL STORAGE SYSTEMS AND COMPONENT PARTS; AUTOMOBILE ENGINES; AUTOMOTIVE ENGINE MOUNTS; ENGINES FOR LAND VEHICLES; LAND VEHICLE TRANSMISSIONS AND REPLACEMENT PARTS THEREOF; TRANSMISSION MOUNTING PLATES FOR LAND VEHICLES; VEHICLE PARTS, NAMELY, STEERING WHEELS, WHEELS, WINDSHIELDS, DIFFERENTIALS, DRIVE BELTS, AXLES, FENDERS, RUNNING BOARDS, SHOCK ABSORBERS, SUSPENSION STRUTS, REARVIEW MIRRORS; VEHICLE WHEEL RIMS AND STRUCTURAL PARTS THEREFOR; LAND VEHICLES AND STRUCTURAL PARTS THEREFOR (U.S. CLS. 19, 21, 23, 31, 35 AND 44).

FIRST USE 1-1-1980; IN COMMERCE 1-1-1980.
ALAIN LAPTER, EXAMINING ATTORNEY

CLASS 12—(Continued).

SN 85-411,876. 9158-7147 QUEBEC INC., BOUCHERVILLE, QUEBEC, CANADA, FILED 8-31-2011.

T-REX

THE MARK CONSISTS OF STANDARD CHARACTERS WITHOUT CLAIM TO ANY PARTICULAR FONT, STYLE, SIZE, OR COLOR.

OWNER OF U.S. REG. NO. 2,358,955.

FOR LAND MOTOR VEHICLES, NAMELY, THREE-WHEELED VEHICLES (U.S. CLS. 19, 21, 23, 31, 35 AND 44).

FIRST USE 12-31-1994; IN COMMERCE 12-31-2001.

MARLENE BELL, EXAMINING ATTORNEY

SN 85-420,063. GEASON ENTERPRISES, LLC, DBA HAMMERHEAD OFF-ROAD, FLOWER MOUND, TX. FILED 9-12-2011.

HAMMERHEAD OFF-ROAD

THE MARK CONSISTS OF STANDARD CHARACTERS WITHOUT CLAIM TO ANY PARTICULAR FONT, STYLE, SIZE, OR COLOR.

NO CLAIM IS MADE TO THE EXCLUSIVE RIGHT TO USE "OFF-ROAD", APART FROM THE MARK AS SHOWN.

FOR OFF-ROAD VEHICLES, NAMELY, GO-KARTS, DUNE BUGGIES, ATVS, UTVS, NEIGHBORHOOD ELECTRIC VEHICLES (NEVS), AND SCOOTERS (U.S. CLS. 19, 21, 23, 31, 35 AND 44).

FIRST USE 11-30-2007; IN COMMERCE 11-30-2007.
SKYE YOUNG, EXAMINING ATTORNEY

SN 85-420,072. GEASON ENTERPRISES, LLC, DBA HAMMERHEAD OFF-ROAD, FLOWER MOUND, TX. FILED 9-12-2011.



NO CLAIM IS MADE TO THE EXCLUSIVE RIGHT TO USE "OFF-ROAD", APART FROM THE MARK AS SHOWN.

THE MARK CONSISTS OF THE WORDS "HAMMERHEAD" AND "OFF-ROAD" IN A STYLIZED, SHADOWED FONT, AND SEPARATED BY AN IMAGE OF A HAMMERHEAD SHARK.

FOR OFF-ROAD VEHICLES, NAMELY, GO-KARTS, DUNE BUGGIES, ATVS, UTVS, NEIGHBORHOOD ELECTRIC VEHICLES (NEVS), AND SCOOTERS (U.S. CLS. 19, 21, 23, 31, 35 AND 44).

FIRST USE 11-30-2007; IN COMMERCE 11-30-2007.
SKYE YOUNG, EXAMINING ATTORNEY

CLASS 12—(Continued).

SN 85-433,124. AMERICAN AXLE & MANUFACTURING, INC., DETROIT, MI. FILED 9-27-2011.



THE MARK CONSISTS OF THE WORD "ECOTRAC", WITH THE FIRST LETTER "C" IN THE WORD INCLUDING AN ARROW AND THE LETTER "T" IN THE WORD INCLUDING AN ARROW GOING ACROSS THE LETTERS "RAC".

FOR ALL WHEEL DRIVE SYSTEM FOR LAND VEHICLES COMPRISED PRIMARILY OF DIFFERENTIAL, REAR DRIVE MODULE, HALF SHAFT, PROPELLER SHAFT AND POWER TRANSFER UNIT (U.S. CLS. 19, 21, 23, 31, 35 AND 44).

TINA MAI, EXAMINING ATTORNEY

SN 85-433,129. AMERICAN AXLE & MANUFACTURING, INC., DETROIT, MI. FILED 9-27-2011.



THE COLOR(S) GREEN AND LIGHT GREEN IS/ARE CLAIMED AS A FEATURE OF THE MARK.

THE MARK CONSISTS OF THE WORD "ECOTRAC" IN GREEN EXCEPT THE FIRST LETTER "C" IS IN LIGHT GREEN AND INCLUDES AN ARROW; AND THE LETTER "T" INCLUDES AN ARROW GOING ACROSS THE LETTERS "RAC".

FOR ALL WHEEL DRIVE SYSTEM FOR LAND VEHICLES COMPRISED PRIMARILY OF DIFFERENTIAL, REAR DRIVE MODULE, HALF SHAFT, PROPELLER SHAFT AND POWER TRANSFER UNIT (U.S. CLS. 19, 21, 23, 31, 35 AND 44).

TINA MAI, EXAMINING ATTORNEY

CLASS 12—(Continued).

SN 85-446,482. JDCI ENTERPRISES, INC. DBA BOATMASTER TRAILERS, FORT MYERS, FL. FILED 10-13-2011.

BOATMASTER ULTRALIGHT

THE MARK CONSISTS OF STANDARD CHARACTERS WITHOUT CLAIM TO ANY PARTICULAR FONT, STYLE, SIZE, OR COLOR.

OWNER OF U.S. REG. NO. 2,951,086.

NO CLAIM IS MADE TO THE EXCLUSIVE RIGHT TO USE "ULTRALIGHT", APART FROM THE MARK AS SHOWN.

FOR RECREATIONAL VEHICLES, NAMELY, TOWABLE TRAILERS; TRAILERS (U.S. CLS. 19, 21, 23, 31, 35 AND 44).

FIRST USE 6-1-2011; IN COMMERCE 6-1-2011.

DAVID HOFFMAN, EXAMINING ATTORNEY

SN 85-446,623. DINGHY PLANET, LLC, DBA KO SAILING, SEABROOK, TX. FILED 10-13-2011.

BLUEBLUE

THE MARK CONSISTS OF STANDARD CHARACTERS WITHOUT CLAIM TO ANY PARTICULAR FONT, STYLE, SIZE, OR COLOR.

FOR BOATS (U.S. CLS. 19, 21, 23, 31, 35 AND 44).

AMY C. KEAN, EXAMINING ATTORNEY

SN 85-446,640. DINGHY PLANET, LLC, DBA KO SAILING, SEABROOK, TX. FILED 10-13-2011.

BLUEMAGIC

THE MARK CONSISTS OF STANDARD CHARACTERS WITHOUT CLAIM TO ANY PARTICULAR FONT, STYLE, SIZE, OR COLOR.

FOR BOATS (U.S. CLS. 19, 21, 23, 31, 35 AND 44).

AMY C. KEAN, EXAMINING ATTORNEY

CLASS 12—(Continued).

SN 85-447,243. SEATCURE LLC, WINDSOR, CO. FILED 10-13-2011.

SEATCURE

THE MARK CONSISTS OF STANDARD CHARACTERS WITHOUT CLAIM TO ANY PARTICULAR FONT, STYLE, SIZE, OR COLOR.

FOR CHILD AND INFANT RESTRAINTS FOR VEHICLE SEATS (U.S. CLS. 19, 21, 23, 31, 35 AND 44).
TEJBIR SINGH, EXAMINING ATTORNEY

SN 85-447,756. TAP WORLDWIDE, LLC, COMPTON, CA. FILED 10-14-2011.

PRO RUNNER

THE MARK CONSISTS OF STANDARD CHARACTERS WITHOUT CLAIM TO ANY PARTICULAR FONT, STYLE, SIZE, OR COLOR.

FOR LAND VEHICLE PARTS AND ACCESSORIES, NAMELY, STRUCTURAL PARTS FOR LAND VEHICLES, SHOCK ABSORBERS, SHOCK MOUNTS, SHOCK BRACKETS, PITMAN ARMS, STEERING ARMS, TIRE RODS, STEERING DAMPENERS, REAR STABILIZER BARS AND SUSPENSION SYSTEMS FOR LAND VEHICLES (U.S. CLS. 19, 21, 23, 31, 35 AND 44).
KEVIN CORWIN, EXAMINING ATTORNEY

SN 85-447,773. TAP WORLDWIDE, LLC, LOS ANGELES, CA. FILED 10-14-2011.

VSRT

THE MARK CONSISTS OF STANDARD CHARACTERS WITHOUT CLAIM TO ANY PARTICULAR FONT, STYLE, SIZE, OR COLOR.

FOR LAND VEHICLE PARTS AND ACCESSORIES, NAMELY, STRUCTURAL PARTS FOR LAND VEHICLES, SHOCK ABSORBERS, SHOCK MOUNTS, SHOCK BRACKETS, PITMAN ARMS, STEERING ARMS, TIRE RODS, STEERING DAMPENERS, REAR STABILIZER BARS AND SUSPENSION SYSTEMS FOR LAND VEHICLES (U.S. CLS. 19, 21, 23, 31, 35 AND 44).
KEVIN CORWIN, EXAMINING ATTORNEY

CLASS 12—(Continued).

SN 85-448,006. AXMAN ENTERPRISE CO., LTD., CHANGHUA COUNTY, TAIWAN, FILED 10-14-2011.



OWNER OF TAIWAN REG. NO. 01295011, DATED 1-1-2008, EXPIRES 12-31-2017.

THE MARK CONSISTS OF THE TERM AXMAN IN STYLIZED LETTERING.

FOR BICYCLES; BICYCLE PARTS AND FITTINGS, NAMELY, BICYCLE PEDALS, HANDLE BAR STEMS, STEM JOINTS, RACING BICYCLE FRAMES, FORK CROWN COVERS, BICYCLE BELLS, BICYCLE SADDLES, BICYCLE HANDLE BARS, FRONT FORK JOINTS, FRONT FORK, BICYCLE FREEWHEELS, BICYCLE STANDS, BICYCLE KICKSTANDS, DIRECTION INDICATORS FOR BICYCLES (U.S. CLS. 19, 21, 23, 31, 35 AND 44).

GIANCARLO CASTRO, EXAMINING ATTORNEY

SN 85-448,389. SABERTOOTH MOTORCYCLES, LLC, NEEDHAM, MA. FILED 10-16-2011.

Riding redefined

THE MARK CONSISTS OF STANDARD CHARACTERS WITHOUT CLAIM TO ANY PARTICULAR FONT, STYLE, SIZE, OR COLOR.

FOR LAND VEHICLES (U.S. CLS. 19, 21, 23, 31, 35 AND 44).

FIRST USE 2-1-2006; IN COMMERCE 3-1-2006.

MARK SHINER, EXAMINING ATTORNEY

SN 85-448,877. EUGENE R. REDA, WEST MILFORD, NJ. FILED 10-17-2011.

HELMET HOOKER

THE MARK CONSISTS OF STANDARD CHARACTERS WITHOUT CLAIM TO ANY PARTICULAR FONT, STYLE, SIZE, OR COLOR.

NO CLAIM IS MADE TO THE EXCLUSIVE RIGHT TO USE "HELMET", APART FROM THE MARK AS SHOWN.

FOR A ONE-PIECE BRACKET THAT SLIPS OVER THE LIP OF A MOTORCYCLE SADDLEBAG, AND FUNCTIONS AS A SECURE HANGER AND RETENTION DEVICE FOR A HELMET (U.S. CLS. 19, 21, 23, 31, 35 AND 44).

FIRST USE 10-31-2009; IN COMMERCE 1-24-2010.

MICHAEL WIENER, EXAMINING ATTORNEY

CLASS 12—(Continued).

SN 85-449,966. WHEATON MARINE, LLC, STUART, FL.
FILED 10-18-2011.

WHEATON MARINE

THE MARK CONSISTS OF STANDARD CHARACTERS WITHOUT CLAIM TO ANY PARTICULAR FONT, STYLE, SIZE, OR COLOR.

NO CLAIM IS MADE TO THE EXCLUSIVE RIGHT TO USE "MARINE", APART FROM THE MARK AS SHOWN, FOR MOTOR DRIVEN BOATS (U.S. CLS. 19, 21, 23, 31, 35 AND 44).

KAPIL BHANOT, EXAMINING ATTORNEY

CLASS 12—(Continued).

SN 85-458,596. SABERTOOTH MOTORCYCLES, LLC, NEEDHAM, MA. FILED 10-28-2011.

Predator

THE MARK CONSISTS OF STANDARD CHARACTERS WITHOUT CLAIM TO ANY PARTICULAR FONT, STYLE, SIZE, OR COLOR.

FOR MOTORCYCLE ENGINES (U.S. CLS. 19, 21, 23, 31, 35 AND 44).

FIRST USE 2-1-2006; IN COMMERCE 3-1-2006.

MARK SHINER, EXAMINING ATTORNEY

SN 85-450,037. WHEATON MARINE, LLC, STUART, FL.
FILED 10-18-2011.

FROM LEGEND TO LEGENDARY

THE MARK CONSISTS OF STANDARD CHARACTERS WITHOUT CLAIM TO ANY PARTICULAR FONT, STYLE, SIZE, OR COLOR.

FOR MOTOR DRIVEN BOATS (U.S. CLS. 19, 21, 23, 31, 35 AND 44).

KAPIL BHANOT, EXAMINING ATTORNEY

SN 85-460,108. MACNEIL IP LLC, BOLINGBROOK, IL.
FILED 10-31-2011.

TECHLINER

THE MARK CONSISTS OF STANDARD CHARACTERS WITHOUT CLAIM TO ANY PARTICULAR FONT, STYLE, SIZE, OR COLOR.

FOR FITTED PICKUP TRUCK BED LINERS (U.S. CLS. 19, 21, 23, 31, 35 AND 44).

MICHAEL WIENER, EXAMINING ATTORNEY

SN 85-450,417. SUNRISE MEDICAL (US) LLC, FRESNO, CA.
FILED 10-18-2011.

SpiderTrac

THE MARK CONSISTS OF STANDARD CHARACTERS WITHOUT CLAIM TO ANY PARTICULAR FONT, STYLE, SIZE, OR COLOR.

FOR A WHEELCHAIR FEATURE, NAMELY, A SUSPENSION FEATURE OF A WHEELCHAIR (U.S. CLS. 19, 21, 23, 31, 35 AND 44).

GINA HAYES, EXAMINING ATTORNEY

SN 85-461,684. FEDERAL-MOGUL IGNITION COMPANY,
SOUTHFIELD, MI. FILED 11-1-2011.

GENESIS

THE MARK CONSISTS OF STANDARD CHARACTERS WITHOUT CLAIM TO ANY PARTICULAR FONT, STYLE, SIZE, OR COLOR.

FOR WINDSHIELD WIPERS; WINDSHIELD WIPER BLADES (U.S. CLS. 19, 21, 23, 31, 35 AND 44).

YAT SYE, LEE, EXAMINING ATTORNEY

CLASS 12—(Continued).

SN 85-461,691. FEDERAL-MOGUL IGNITION COMPANY, SOUTHFIELD, MI. FILED 11-1-2011.

ACCUFIT

THE MARK CONSISTS OF STANDARD CHARACTERS WITHOUT CLAIM TO ANY PARTICULAR FONT, STYLE, SIZE, OR COLOR.

FOR WINDSHIELD WIPERS; WINDSHIELD WIPER BLADES (U.S. CLS. 19, 21, 23, 31, 35 AND 44).
YAT SYE, LEE, EXAMINING ATTORNEY

SN 85-473,812. FORD MOTOR COMPANY, DEARBORN, MI. FILED 11-16-2011.



OWNER OF U.S. REG. NO. 3,715,207.
THE COLOR(S) BLUE, GREEN, SILVER AND GRAY IS/ARE CLAIMED AS A FEATURE OF THE MARK.

THE MARK CONSISTS OF THE WORD "ENERGI" WITH AN IMAGE OF A BLUE AND GRAY ROAD TURNING INTO A GREEN AND BLUE LEAF TO THE RIGHT OF THE WORD. THE "E" IS IN GREEN AND IS OUTLINED BY A SILVER ELECTRICAL PLUG. THE REST OF THE WORD "NERGI" IS IN SILVER WITH A DARK GRAY BACKGROUND.

FOR PLUG-IN HYBRID-ELECTRIC VEHICLES, NAMELY, AUTOMOBILES (U.S. CLS. 19, 21, 23, 31, 35 AND 44).

DEZMONA MIZELLE, EXAMINING ATTORNEY

SN 85-482,982. SABERTOOTH MOTORCYCLES, LLC, CHESTNUT HILL, MA. FILED 11-29-2011.

TropicCat

THE MARK CONSISTS OF STANDARD CHARACTERS WITHOUT CLAIM TO ANY PARTICULAR FONT, STYLE, SIZE, OR COLOR.

FOR ATVS (ALL TERRAIN VEHICLES); BICYCLES; ELECTRIC MOTORCYCLES; ELECTRIC VEHICLES, NAMELY, ALL TERRAIN VEHICLES, PERSONAL JET BOATS; FOUR-WHEELED MOTOR VEHICLES; GEARBOXES; LUGGAGE SPECIALLY ADAPTED FOR USE ON MOTORCYCLES; MOTOR SCOOTERS; MOTORCYCLE ENGINES; MOTORCYCLES; MOTORCYCLES AND STRUCTURAL PARTS THEREFOR; PERSONAL WATERCRAFT, NAMELY, PERSONAL JET BOATS; SCOOTERS; SCOOTERS AND STRUCTURAL PARTS THEREFOR; TRAILERS; UTVS (UTILITY TERRAIN VEHICLES) (U.S. CLS. 19, 21, 23, 31, 35 AND 44).

FIRST USE 7-1-2008; IN COMMERCE 8-1-2008.

MARK SHINER, EXAMINING ATTORNEY

CLASS 12—(Continued).

SN 85-483,037. SABERTOOTH MOTORCYCLES, LLC, CHESTNUT HILL, MA. FILED 11-29-2011.

Sabertooth

THE MARK CONSISTS OF STANDARD CHARACTERS WITHOUT CLAIM TO ANY PARTICULAR FONT, STYLE, SIZE, OR COLOR.

OWNER OF U.S. REG. NOS. 3,341,538, 3,375,323 AND 3,554,107.

FOR AERO-DYNAMIC FAIRINGS FOR VEHICLES; ALL TERRAIN VEHICLES (ATVS); ATVS (ALL TERRAIN VEHICLES); AUTOMOBILE BODIES; AUTOMOBILE ENGINES; AUTOMOBILES; AUTOMOBILES AND STRUCTURAL PARTS THEREFOR; BICYCLES; BODIES FOR VEHICLES; BRAKES FOR VEHICLES; CARGO CARRIERS FOR VEHICLES; CARGO TRAILERS; CARS; CARTS; CHASSIS FOR MOTOR VEHICLES; ELECTRIC DRIVES FOR VEHICLES; ELECTRIC MOTORCYCLES; ELECTRIC VEHICLES, NAMELY, ALL TERRAIN VEHICLES, SNOWMOBILES, PERSONAL JET BOATS; ENGINES FOR LAND VEHICLES; FOUR-WHEELED MOTOR VEHICLES; GEARBOXES; LAND VEHICLE PARTS, NAMELY, TRANSMISSIONS; LAND VEHICLES; MIRRORS FOR VEHICLES, NAMELY, REAR VIEW MIRRORS; MOTOR SCOOTERS; MOTORBIKES; MOTORCYCLE BAGS, NAMELY, TANK BAGS, SADDLE BAGS, SISSY BAR BAGS AND TAIL BAGS; MOTORCYCLE ENGINES; MOTORCYCLES; MOTORCYCLES AND STRUCTURAL PARTS THEREFOR; MOTORISED WHEELCHAIRS FOR THE DISABLED AND THOSE WITH MOBILITY DIFFICULTIES; MOTORIZED GOLF CARTS; MOTORIZED SCOOTERS; MOTORIZED SCOOTERS AND STRUCTURAL PARTS THEREFOR; MOTORIZED VEHICLES, NAMELY, UNDERWATER DIVER PROPULSION VEHICLES; MOTORS FOR LAND VEHICLES; PERSONAL WATERCRAFT, NAMELY, PERSONAL JET BOATS; ROOF RACK STORAGE CONTAINERS FOR LAND VEHICLES; SCOOTERS; SCOOTERS AND STRUCTURAL PARTS THEREFOR; SNOWMOBILES; TRAILERS; TRANSMISSIONS FOR LAND VEHICLES; TRICYCLES; VEHICLE POWER TRAIN MECHANISM COMPRISED OF CLUTCH, TRANSMISSION, DRIVE SHAFT, AND DIFFERENTIAL (U.S. CLS. 19, 21, 23, 31, 35 AND 44).

FIRST USE 10-1-2006; IN COMMERCE 2-1-2007.

MARK SHINER, EXAMINING ATTORNEY

CLASS 12—(Continued).

SN 85-490,577. GUCCI AMERICA, INC., NEW YORK, NY.
FILED 12-8-2011.



OWNER OF U.S. REG. NOS. 1,158,170, 3,470,140 AND
OTHERS.

THE MARK CONSISTS OF THE INTERLOCKING STY-
LIZED LETTERS "GG".
FOR AUTOMOBILES AND BOATS (U.S. CLS. 19, 21, 23,
31, 35 AND 44).
DAWN HAN, EXAMINING ATTORNEY

SN 85-491,222. SUNRISE MEDICAL (US) LLC, FRESNO, CA.
FILED 12-9-2011.

ZIPPIE VOYAGE

THE MARK CONSISTS OF STANDARD CHARACTERS
WITHOUT CLAIM TO ANY PARTICULAR FONT, STYLE,
SIZE, OR COLOR.

OWNER OF U.S. REG. NO. 1,563,267.
FOR STROLLERS (U.S. CLS. 19, 21, 23, 31, 35 AND 44).
GINA HAYES, EXAMINING ATTORNEY

SN 85-494,975. FORD MOTOR COMPANY, DEARBORN, MI.
FILED 12-14-2011.

FIGO

THE MARK CONSISTS OF STANDARD CHARACTERS
WITHOUT CLAIM TO ANY PARTICULAR FONT, STYLE,
SIZE, OR COLOR.

THE ENGLISH TRANSLATION OF "FIGO" IS AN ITA-
LIAN SLANG WORD MEANING "COOL".
FOR PASSENGER AUTOMOBILES (U.S. CLS. 19, 21,
23, 31, 35 AND 44).
DEZMONA MIZELLE, EXAMINING ATTORNEY

CLASS 12—(Continued).

SN 85-495,039. TREK BICYCLE CORPORATION, WATER-
LOO, WI. FILED 12-14-2011.

Stacked Lacing

THE MARK CONSISTS OF STANDARD CHARACTERS
WITHOUT CLAIM TO ANY PARTICULAR FONT, STYLE,
SIZE, OR COLOR.

NO CLAIM IS MADE TO THE EXCLUSIVE RIGHT TO
USE "LACING", APART FROM THE MARK AS SHOWN.
FOR BICYCLE WHEELS (U.S. CLS. 19, 21, 23, 31, 35
AND 44).

AHSEN KHAN, EXAMINING ATTORNEY

CLASS 13—FIREARMS

SN 85-444,453. SIG SAUER INC., EXETER, NH. FILED 10-11-
2011.

SIG556Xi

THE MARK CONSISTS OF STANDARD CHARACTERS
WITHOUT CLAIM TO ANY PARTICULAR FONT, STYLE,
SIZE, OR COLOR.

OWNER OF U.S. REG. NO. 3,462,946.
FOR FIREARMS (U.S. CLS. 2 AND 9).
TARAH HARDY, EXAMINING ATTORNEY

SN 85-445,786. CROSMAN CORPORATION, BLOOMFIELD,
NY. FILED 10-12-2011.

CAMO AMMO

THE MARK CONSISTS OF STANDARD CHARACTERS
WITHOUT CLAIM TO ANY PARTICULAR FONT, STYLE,
SIZE, OR COLOR.

NO CLAIM IS MADE TO THE EXCLUSIVE RIGHT TO
USE "AMMO", APART FROM THE MARK AS SHOWN.
FOR AMMUNITION (U.S. CLS. 2 AND 9).
FIRST USE 10-19-2004; IN COMMERCE 10-19-2004.
ALICIA COLLINS, EXAMINING ATTORNEY

CLASS 13—(Continued).

SN 85-446,313. GLOBAL GUNS & HUNTING, INC., OLATHE, KS. FILED 10-13-2011.

BUD9

THE MARK CONSISTS OF STANDARD CHARACTERS WITHOUT CLAIM TO ANY PARTICULAR FONT, STYLE, SIZE, OR COLOR.

FOR GUNS (U.S. CLS. 2 AND 9).
JAMES GRIFFIN, EXAMINING ATTORNEY

CLASS 13—(Continued).

SN 85-448,178. SKY KING UNLIMITED, INC., PORT ST. LUCIE, FL. FILED 10-14-2011.



OWNER OF U.S. REG. NOS. 3,368,776 AND 3,372,022.
NO CLAIM IS MADE TO THE EXCLUSIVE RIGHT TO USE "FIREWORKS", APART FROM THE MARK AS SHOWN.

THE MARK CONSISTS OF A FANCIFUL DEPICTION OF A KING WEARING SUNGLASSES, A CROWN, AND HOLDING A STAFF, THE TOP PORTION OF SUCH STAFF HAVING AN EXPLOSION EXTRUDING THEREFROM, ALL OF THE ABOVE HAVING A CIRCULAR OUTLINED BACKGROUND, ALL OF THE ABOVE BEING ON TOP OF THE STYLIZED WORDING OF "SKY KING FIREWORKS", THE WORDS "SKY KING" HAVING BURNING FUSES THEREUNDER, AND THE WORD "FIREWORKS" BEING ON A BANNER UNDER THE WORDS "SKY KING".

FOR FIREWORKS (U.S. CLS. 2 AND 9).
FIRST USE 5-1-2004; IN COMMERCE 5-1-2004.
GRETTA YAO, EXAMINING ATTORNEY

SN 85-448,168. SKY KING UNLIMITED, INC., PORT ST. LUCIE, FL. FILED 10-14-2011.

SKY KING

THE MARK CONSISTS OF STANDARD CHARACTERS WITHOUT CLAIM TO ANY PARTICULAR FONT, STYLE, SIZE, OR COLOR.

OWNER OF U.S. REG. NO. 3,368,776.
FOR FIREWORKS (U.S. CLS. 2 AND 9).
FIRST USE 5-1-1981; IN COMMERCE 5-1-1981.
GRETTA YAO, EXAMINING ATTORNEY

SN 85-448,674. TURNBULL MAUNUFACTURING CO. INC., BLOOMFIELD, NY. FILED 10-17-2011.



THE MARK CONSISTS OF A PICTURE OF A TURNING BULL, STANDING ON HIS HIND LEGS, STANDING ON THE EARTH, INSIDE OF A CIRCLE. THE BULL IS TURNING TOWARD HIS RIGHT.

FOR FIREARMS (U.S. CLS. 2 AND 9).
WILLIAM JACKSON, EXAMINING ATTORNEY

CLASS 13—(Continued).

SN 85-448,982. SKY KING UNLIMITED, INC., PORT ST. LUCIE, FL. FILED 10-17-2011.

3D

THE MARK CONSISTS OF STANDARD CHARACTERS WITHOUT CLAIM TO ANY PARTICULAR FONT, STYLE, SIZE, OR COLOR.
FOR FIREWORKS (U.S. CLS. 2 AND 9).
FIRST USE 10-13-2011; IN COMMERCE 10-13-2011.
GRETTA YAO, EXAMINING ATTORNEY

SN 85-449,843. SKY KING UNLIMITED, INC., PORT ST. LUCIE, FL. FILED 10-18-2011.



NO CLAIM IS MADE TO THE EXCLUSIVE RIGHT TO USE "PYRO", APART FROM THE MARK AS SHOWN.
THE MARK CONSISTS OF A RECTANGULAR BOX WITH ROUNDED CORNERS CONTAINING THE STYLIZED WORDING "3D PYRO", SURROUNDED BY A BORDER HAVING ROUNDED CORNERS.
FOR FIREWORKS (U.S. CLS. 2 AND 9).
FIRST USE 10-13-2011; IN COMMERCE 10-13-2011.
GRETTA YAO, EXAMINING ATTORNEY

SN 85-449,914. SPRINGFIELD, INC., GENESEO, IL. FILED 10-18-2011.

ASSISTANT

THE MARK CONSISTS OF STANDARD CHARACTERS WITHOUT CLAIM TO ANY PARTICULAR FONT, STYLE, SIZE, OR COLOR.
FOR FIREARMS (U.S. CLS. 2 AND 9).
BRIAN PINO, EXAMINING ATTORNEY

CLASS 13—(Continued).

SN 85-449,920. SPRINGFIELD, INC., GENESEO, IL. FILED 10-18-2011.

ASSIST

THE MARK CONSISTS OF STANDARD CHARACTERS WITHOUT CLAIM TO ANY PARTICULAR FONT, STYLE, SIZE, OR COLOR.
FOR FIREARMS (U.S. CLS. 2 AND 9).
BRIAN PINO, EXAMINING ATTORNEY

SN 85-449,927. SPRINGFIELD, INC., GENESEO, IL. FILED 10-18-2011.

XDS

THE MARK CONSISTS OF STANDARD CHARACTERS WITHOUT CLAIM TO ANY PARTICULAR FONT, STYLE, SIZE, OR COLOR.
FOR FIREARMS (U.S. CLS. 2 AND 9).
BRIAN PINO, EXAMINING ATTORNEY

SN 85-457,276. FLEET WHOLESALE SUPPLY CO., INC., APPLETON, WI. FILED 10-26-2011.



OWNER OF U.S. REG. NO. 4,085,283.
THE MARK CONSISTS OF THE IMAGE OF A WOMAN WITH A TAIL SITTING AND LOOKING OVER HER SHOULDER WITH GUNS CROSSED IN FRONT OF HER.
FOR GUNS (U.S. CLS. 2 AND 9).
MARY ROSSMAN, EXAMINING ATTORNEY

CLASS 13—(Continued).

SN 85-975,968. AUSTIN PRECISION PRODUCTS INC., DBA LARUE TACTICAL, LEANDER, TX. FILED 8-2-2011.

LARUE

THE MARK CONSISTS OF STANDARD CHARACTERS WITHOUT CLAIM TO ANY PARTICULAR FONT, STYLE, SIZE, OR COLOR.
SEC. 2(F).
FOR FIREARMS (U.S. CLS. 2 AND 9).
FIRST USE 5-13-2004; IN COMMERCE 5-13-2004.
ANDREW LEASER, EXAMINING ATTORNEY

CLASS 14—JEWELRY

SN 76-709,528. META WATCH, LTD., DALLAS, TX. FILED 10-25-2011.

METAWATCH

THE MARK CONSISTS OF STANDARD CHARACTERS WITHOUT CLAIM TO ANY PARTICULAR FONT, STYLE, SIZE, OR COLOR.
FOR WATCHES; NAMELY, WATCHES WITH WIRELESS COMMUNICATION CAPABILITIES (U.S. CLS. 2, 27, 28 AND 50).
FIRST USE 10-1-2011; IN COMMERCE 10-1-2011.
DORITT L. CARROLL, EXAMINING ATTORNEY

SN 77-946,986. RUVEN GERSH, TEL AVIV 69400, ISRAEL, FILED 3-1-2010.

LOTUS CUT

THE MARK CONSISTS OF STANDARD CHARACTERS WITHOUT CLAIM TO ANY PARTICULAR FONT, STYLE, SIZE, OR COLOR.
NO CLAIM IS MADE TO THE EXCLUSIVE RIGHT TO USE "CUT", APART FROM THE MARK AS SHOWN.
FOR PRECIOUS STONES AND DIAMONDS (U.S. CLS. 2, 27, 28 AND 50).
JEAN IM, EXAMINING ATTORNEY

CLASS 14—(Continued).

SN 79-099,565. LIMITED LIABILITY COMPANY "VIANNA FASHION COMPANY", RUSSIAN FED., FILED 2-25-2011.

Vianna Fashion

THE MARK CONSISTS OF STANDARD CHARACTERS WITHOUT CLAIM TO ANY PARTICULAR FONT, STYLE, SIZE, OR COLOR.
PRIORITY DATE OF 9-10-2010 IS CLAIMED.
OWNER OF INTERNATIONAL REGISTRATION 1083082 DATED 2-25-2011, EXPIRES 2-25-2021.
NO CLAIM IS MADE TO THE EXCLUSIVE RIGHT TO USE "FASHION", APART FROM THE MARK AS SHOWN.
FOR JEWELLERY, BRACELETS; STRAPS FOR WRISTWATCHES; CHARMS; BROOCHES; PINS; TIE PINS; PEARLS MADE OF AMBROID IN THE NATURE OF PRESSED AMBER; PEARLS, UNWROUGHT OR SEMI-WROUGHT; WORKS OF ART OF PRECIOUS METAL; NECKLACES; RINGS; MEDALLIONS; EARRINGS; PASTE JEWELLERY BEING COSTUME JEWELRY; ORNAMENTS IN THE NATURE OF JEWELLERY; CHAINS BEING JEWELRY; WATCHES; WRISTWATCHES; JEWELLERY CASES IN THE NATURE OF CASKETS (U.S. CLS. 2, 27, 28 AND 50).
LAURA HAMMEL, EXAMINING ATTORNEY

SN 79-102,231. LUCA GAGGIOTTI, I-20059 VIMERCATE, ITALY, AND DAVID JOSHACH, I-20146 MILANO, ITALY, AND JACOV JOSHACH, I-20146 MILANO, ITALY, FILED 7-11-2011.

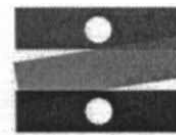

DUEPUNTI

PRIORITY DATE OF 5-20-2011 IS CLAIMED.
OWNER OF INTERNATIONAL REGISTRATION 1089845 DATED 7-11-2011, EXPIRES 7-11-2021.
THE MARK CONSISTS OF THE WORDING "DUEPUNTI" UNDER THREE SHADED RECTANGLES, TWO OF WHICH HAVE UN-SHADED CIRCLES WITHIN THEM.
THE ENGLISH TRANSLATION OF "DUEPUNTI" IN THE MARK IS "TWO POINTS".
FOR PRECIOUS METALS AND THEIR ALLOYS AND GOODS IN PRECIOUS METALS OR COATED THEREWITH, NAMELY, RINGS, EARRINGS, PENDANTS, BRACELETS, NECKLACES, KEY-RINGS, BROOCHES AND CUFFLINKS; JEWELLERY, PRECIOUS STONES, HOROLOGICAL AND CHRONOMETRIC INSTRUMENTS, NAMELY, CLOCKS, WATCH PARTS, WATCH BANDS, WATCH CLASPS (U.S. CLS. 2, 27, 28 AND 50).
FRED CARL, EXAMINING ATTORNEY

CLASS 14—(Continued).

SN 85-208,395. BAMBOOPINK, IRVINE, CA. FILED 12-30-2010.

bamboopink
by judefrances

THE NAME(S), PORTRAIT(S), AND/OR SIGNATURE(S) SHOWN IN THE MARK DOES NOT IDENTIFY A PARTICULAR LIVING INDIVIDUAL.

THE MARK CONSISTS OF THE WORDING "BAMBOOPINK" WITH A LOVE KNOT LOGO REPRESENTING THE DOT AT THE TOP OF THE LETTER "I" AND THE WORDING "BY JUDEFRANCES" IN A SMALLER FONT BELOW THE LETTERS "MBOO" OF THE WORD "BAMBOO".

FOR JEWELRY (U.S. CLS. 2, 27, 28 AND 50).
MICHAEL WEBSTER, EXAMINING ATTORNEY

SN 85-274,335. MASCOTTE HOLDINGS, INC., NEW YORK, NY. FILED 3-23-2011.

YEEZI

THE MARK CONSISTS OF STANDARD CHARACTERS WITHOUT CLAIM TO ANY PARTICULAR FONT, STYLE, SIZE, OR COLOR.

THE NAME SHOWN IN THE MARK IDENTIFIES KANYE WEST A LIVING INDIVIDUAL, WHOSE CONSENT TO REGISTER IS MADE OF RECORD.

FOR JEWELRY; JEWELRY FINDINGS; GEMSTONE AND PRECIOUS STONES; SEMI-PRECIOUS STONES; PEARLS; OPALS; PLATINUM AND ITS ALLOYS; PRECIOUS METALS; CHARMS, CHOKERS, AND PENDANTS; LAPEL PINS; ORNAMENTAL LAPEL PINS; PINS BEING JEWELRY; BODY-PIERCING RINGS AND STUDS; EAR STUDS; EAR CLIPS; TIE PINS; TIE CLIPS; TIE BARS; TIE TACKS; TIE FASTENERS; BOLO TIES WITH PRECIOUS METAL TIPS; CUFF-LINKS; SHIRT STUDS; BADGES OF PRECIOUS METAL; COSTUME JEWELRY; JEWELRY CHAINS; JEWELRY PINS FOR USE ON HATS; HAT ORNAMENTS OF PRECIOUS METAL; SHOE ORNAMENTS OF PRECIOUS METAL; ORNAMENTAL PINS OF PRECIOUS METAL; HOLIDAY ORNAMENTS OF PRECIOUS METAL; JEWELRY BOXES AND CASES; KEY HOLDERS OF PRECIOUS METALS; KEY CHAINS OF PRECIOUS METAL; WATCHES; WATCH BRACELETS; WATCH ACCESSORIES, NAMELY, PARTS OF WATCHES; WRISTWATCHES; POCKET WATCHES; STOP WATCHES; WATCH STRAPS AND BANDS; WATCH CHAINS AND FOBS; WATCH CASES; WATCH BOXES; CLOCKS; ALARM CLOCKS; CLOCKS INCORPORATING RADIOS; WALL CLOCKS; TIMEPIECES; BOXES FOR TIMEPIECES; FIGURINES, SCULPTURES, BUSTS, FIGURES, STATUES, AND STATUETTES, ALL OF THE FOREGOING OF PRECIOUS METAL (U.S. CLS. 2, 27, 28 AND 50).

CHARISMA HAMPTON, EXAMINING ATTORNEY

CLASS 14—(Continued).

SN 85-298,885. BRUN, JOHANNE, STE ANNE DE BELLEVUE, CANADA, FILED 4-19-2011.

KWB DESIGNS

THE MARK CONSISTS OF STANDARD CHARACTERS WITHOUT CLAIM TO ANY PARTICULAR FONT, STYLE, SIZE, OR COLOR.

NO CLAIM IS MADE TO THE EXCLUSIVE RIGHT TO USE "DESIGNS", APART FROM THE MARK AS SHOWN.

FOR PRECIOUS METALS, THEIR ALLOYS AND GOODS IN PRECIOUS METALS OR COATED THEREWITH, NAMELY, JEWELRY, RINGS, BRACELETS; SILVER AND GOLD AND ITS ALLOYS; SEMI-PRECIOUS STONES; PRECIOUS AND SEMI-PRECIOUS CRYSTAL STONES AND BEADS FOR USE IN JEWELRY (U.S. CLS. 2, 27, 28 AND 50).

HOWARD SMIGA, EXAMINING ATTORNEY

SN 85-299,518. THE YOGI LLC, HONOLULU, HI. FILED 4-20-2011.

THE YOGI BAND

THE MARK CONSISTS OF STANDARD CHARACTERS WITHOUT CLAIM TO ANY PARTICULAR FONT, STYLE, SIZE, OR COLOR.

NO CLAIM IS MADE TO THE EXCLUSIVE RIGHT TO USE "BAND", APART FROM THE MARK AS SHOWN.

FOR SILICON WRISTBANDS IN THE NATURE OF A BRACELET (U.S. CLS. 2, 27, 28 AND 50).

FIRST USE 3-1-2011; IN COMMERCE 4-1-2011.

ESTHER BELENKER, EXAMINING ATTORNEY

SN 85-301,375. GORDON, HEATHER, JENKINTOWN, PA. FILED 4-21-2011.

ZUZU VINTAGE

THE MARK CONSISTS OF STANDARD CHARACTERS WITHOUT CLAIM TO ANY PARTICULAR FONT, STYLE, SIZE, OR COLOR.

NO CLAIM IS MADE TO THE EXCLUSIVE RIGHT TO USE "VINTAGE", APART FROM THE MARK AS SHOWN.

FOR JEWELRY; VINTAGE COSTUME JEWELRY; VINTAGE FINE JEWELRY; ANTIQUE JEWELRY; ARTISAN AND HANDCRAFTED JEWELRY; FASHION JEWELRY (U.S. CLS. 2, 27, 28 AND 50).

FIRST USE 10-1-2008; IN COMMERCE 1-1-2011.

KATHERINE CONNOLLY, EXAMINING ATTORNEY

CLASS 14—(Continued).

SN 85-315,343. BIJOUX GL, LE CHEYLARD, FRANCE, FILED 5-9-2011.



OWNER OF ERPN CMNTY TM OFC REG. NO. 009280306, DATED 2-10-2011, EXPIRES 7-9-2020.

THE MARK CONSISTS OF THE LETTERS "GL" IN A STYLIZED FONT.

FOR JEWELLERY, PRECIOUS STONES; HOROLOGICAL INSTRUMENTS AND APPARATUS; WATCHES; PRECIOUS METALS AND THEIR ALLOYS; JEWELRY CASES; BOXES OF PRECIOUS METALS; CASES, BRACELETS, CHAINS, SPRINGS, GLASSES, ALL FOR WATCHES; KEY RINGS OF PRECIOUS METAL; CASES FOR CLOCKS AND WATCHES; MEDALS (U.S. CLS. 2, 27, 28 AND 50).

DEZMONA MIZELLE, EXAMINING ATTORNEY

SN 85-364,845. ABIGAIL C SPARKS, LLC, DENVER, CO. FILED 7-7-2011.

ABBY SPARKS

THE MARK CONSISTS OF STANDARD CHARACTERS WITHOUT CLAIM TO ANY PARTICULAR FONT, STYLE, SIZE, OR COLOR.

THE NAME(S), PORTRAIT(S), AND/OR SIGNATURE(S) SHOWN IN THE MARK IDENTIFIES "ABBY SPARKS", WHOSE CONSENT(S) TO REGISTER IS MADE OF RECORD.

FOR JEWELRY (U.S. CLS. 2, 27, 28 AND 50).

FIRST USE 4-10-2011; IN COMMERCE 5-1-2011.

SALLY SHIH, EXAMINING ATTORNEY

SN 85-409,986. BON LESPWI DESIGNS CO., DOVER, FL. FILED 8-29-2011.

BON LESPWI

THE MARK CONSISTS OF STANDARD CHARACTERS WITHOUT CLAIM TO ANY PARTICULAR FONT, STYLE, SIZE, OR COLOR.

THE ENGLISH TRANSLATION OF "BON LESPWI" IN THE MARK IS GOOD SPIRIT.

FOR JEWELRY (U.S. CLS. 2, 27, 28 AND 50).

TRACY CROSS, EXAMINING ATTORNEY

CLASS 14—(Continued).

SN 85-423,238. SC MANUFACTURING, GUAYNABO, PUERTO RICO, FILED 9-15-2011.



NO CLAIM IS MADE TO THE EXCLUSIVE RIGHT TO USE "PARURE", APART FROM THE MARK AS SHOWN.

THE MARK CONSISTS OF THE WORD "PARURE" IN LARGE CAPITALIZED LETTERS. ABOVE THE WORD "PARURE" ARE TWO PAIRS OF SEMICIRCULAR INTERSECTING SHAPES. GOING BETWEEN THE PAIRS OF SEMICIRCULAR SHAPES IS A STYLIZED HORIZONTAL LINE.

THE ENGLISH TRANSLATION OF "PARURE" IN THE MARK IS ADORNMENT.

FOR JEWELRY (U.S. CLS. 2, 27, 28 AND 50).

FIRST USE 5-0-2011; IN COMMERCE 5-0-2011.

WILLIAM JACKSON, EXAMINING ATTORNEY

SN 85-423,612. LAUX, FRANK, KELLER, TX. FILED 9-15-2011.

SACRED SILVER

NO CLAIM IS MADE TO THE EXCLUSIVE RIGHT TO USE "SILVER", APART FROM THE MARK AS SHOWN.

THE MARK CONSISTS OF THE STYLIZED TEXT "SACRED SILVER".

FOR JEWELRY OF SILVER; JEWELRY CHAINS OF SILVER; MEDALS OF SILVER; PENDANTS OF SILVER (U.S. CLS. 2, 27, 28 AND 50).

FIRST USE 8-27-2011; IN COMMERCE 8-28-2011.

RENEE MCCRAY, EXAMINING ATTORNEY

CLASS 14—(Continued).

SN 85-430,260. THE JEWELER'S BENCH, INC., COBDEN, IL. FILED 9-23-2011.



NO CLAIM IS MADE TO THE EXCLUSIVE RIGHT TO USE "DUCKBAND BRAND", APART FROM THE MARK AS SHOWN.

THE MARK CONSISTS OF THE STYLIZED FACE OF A DUCK, WITH CENTER SLANTING EYEBROWS, ABOVE THE WORDING "DUCKBAND BRAND".

FOR JEWELRY (U.S. CLS. 2, 27, 28 AND 50).
FIRST USE 3-15-2011; IN COMMERCE 3-15-2011.
KEVON CHISOLM, EXAMINING ATTORNEY

SN 85-438,060. BLUEFLY, INC., NEW YORK, NY. FILED 10-3-2011.

COLETTE NICOLAI

THE MARK CONSISTS OF STANDARD CHARACTERS WITHOUT CLAIM TO ANY PARTICULAR FONT, STYLE, SIZE, OR COLOR.

THE NAME(S), PORTRAIT(S), AND/OR SIGNATURE(S) SHOWN IN THE MARK DOES NOT IDENTIFY A PARTICULAR LIVING INDIVIDUAL.

FOR DIAMONDS AND JEWELRY (U.S. CLS. 2, 27, 28 AND 50).
TASHIA BUNCH, EXAMINING ATTORNEY

SN 85-443,143. SRULOVICZ, ILAN, MARINA DEL RAY, CA. FILED 10-10-2011.

ÉGARD

THE MARK CONSISTS OF STANDARD CHARACTERS WITHOUT CLAIM TO ANY PARTICULAR FONT, STYLE, SIZE, OR COLOR.

THE ENGLISH TRANSLATION OF "EGARD" IN THE MARK IS RESPECT, CONSIDERATION.

FOR WATCHES (U.S. CLS. 2, 27, 28 AND 50).
JANET LEE, EXAMINING ATTORNEY

CLASS 14—(Continued).

SN 85-446,273. PAVANA USA, INC., NEW YORK, NY. FILED 10-13-2011.

PAVANA

THE MARK CONSISTS OF STANDARD CHARACTERS WITHOUT CLAIM TO ANY PARTICULAR FONT, STYLE, SIZE, OR COLOR.

FOR JEWELLERY AND WATCHES (U.S. CLS. 2, 27, 28 AND 50).
WON TEAK OH, EXAMINING ATTORNEY

SN 85-446,315. HARLIN, MELISSA A., YORK, PA. FILED 10-13-2011.

I KISS MY BULLDOG ON THE LIPS

THE MARK CONSISTS OF STANDARD CHARACTERS WITHOUT CLAIM TO ANY PARTICULAR FONT, STYLE, SIZE, OR COLOR.

FOR BRACELETS (U.S. CLS. 2, 27, 28 AND 50).
JAMES GRIFFIN, EXAMINING ATTORNEY

SN 85-446,594. PRINCESS JEWELRY INC, DBA WEDDING-BANDS.COM, BURNSVILLE, MN. FILED 10-13-2011.

EuroStyle

THE MARK CONSISTS OF STANDARD CHARACTERS WITHOUT CLAIM TO ANY PARTICULAR FONT, STYLE, SIZE, OR COLOR.

FOR BRACELETS; DIAMOND JEWELRY; GEMSTONE JEWELRY; JEWELRY, NAMELY, STONE PENDANTS; RINGS; RINGS BEING JEWELRY; WATCHES; CLOCKS, JEWELRY AND IMITATION JEWELRY; WOMEN'S JEWELRY (U.S. CLS. 2, 27, 28 AND 50).

EMILY CARLSEN, EXAMINING ATTORNEY

CLASS 14—(Continued).

SN 85-447,092. SHANE WALSTER, NORTH SALT LAKE, UT. FILED 10-13-2011.

Jane & Me

THE MARK CONSISTS OF STANDARD CHARACTERS WITHOUT CLAIM TO ANY PARTICULAR FONT, STYLE, SIZE, OR COLOR.

FOR CHARMS; JEWELRY; WOMEN'S JEWELRY (U.S. CLS. 2, 27, 28 AND 50).

FIRST USE 3-5-2010; IN COMMERCE 3-5-2010.
DARRYL SPRUILL, EXAMINING ATTORNEY

SN 85-447,097. SHANE WALSTER, NORTH SALT LAKE, UT. FILED 10-13-2011.

YOU ARE

THE MARK CONSISTS OF STANDARD CHARACTERS WITHOUT CLAIM TO ANY PARTICULAR FONT, STYLE, SIZE, OR COLOR.

FOR CHARMS; JEWELRY; WOMEN'S JEWELRY (U.S. CLS. 2, 27, 28 AND 50).

FIRST USE 3-5-2010; IN COMMERCE 3-5-2010.
DARRYL SPRUILL, EXAMINING ATTORNEY

SN 85-447,771. A REMINDER TO BE KINDER, LLC, NEWPORT BEACH, CA. FILED 10-14-2011.



NO CLAIM IS MADE TO THE EXCLUSIVE RIGHT TO USE THE PICTORIAL REPRESENTATION OF A "RING", APART FROM THE MARK AS SHOWN.

THE COLOR(S) TEAL, BLACK, GRAY, WHITE IS/ARE CLAIMED AS A FEATURE OF THE MARK.

THE MARK CONSISTS OF THE WORDS "A REMINDER TO BE KINDER" IN A TEAL COLOR. A RING IN SHADES OF BLACK, GRAY AND WHITE.

FOR JEWELRY (U.S. CLS. 2, 27, 28 AND 50).
FIRST USE 9-20-2011; IN COMMERCE 9-23-2011.
KHANH LE, EXAMINING ATTORNEY

CLASS 14—(Continued).

SN 85-448,011. EDWARD YEGOR, DBA DEJAS GEMSTONE HEALING ANGELS, KENMORE, NY. FILED 10-14-2011.

GOT ANGEL?

THE MARK CONSISTS OF THE WORDS "GOT ANGEL?" WITH THE HALO OVER THE LETTERS E AND L.

FOR JEWELRY; JEWELRY, NAMELY, STONE PENDANTS; WOMEN'S JEWELRY (U.S. CLS. 2, 27, 28 AND 50).

FIRST USE 8-1-2011; IN COMMERCE 8-1-2011.
STEPHANIE ALI, EXAMINING ATTORNEY

SN 85-448,851. BUDNICK, ANN M, BROOKLYN PARK, MN. FILED 10-17-2011.

Soda Rings

THE MARK CONSISTS OF STANDARD CHARACTERS WITHOUT CLAIM TO ANY PARTICULAR FONT, STYLE, SIZE, OR COLOR.

NO CLAIM IS MADE TO THE EXCLUSIVE RIGHT TO USE "RINGS", APART FROM THE MARK AS SHOWN.

FOR BRACELETS MADE OF SILICONE, RUBBER, PLASTIC OR A COMBINATION THEREOF (U.S. CLS. 2, 27, 28 AND 50).

ELISSA GARBER KON, EXAMINING ATTORNEY

SN 85-449,363. STYLE QUEEN LLC, BEVERLY HILLS, CA. FILED 10-17-2011.

STYLE QUEEN

THE MARK CONSISTS OF STANDARD CHARACTERS WITHOUT CLAIM TO ANY PARTICULAR FONT, STYLE, SIZE, OR COLOR.

NO CLAIM IS MADE TO THE EXCLUSIVE RIGHT TO USE "STYLE", APART FROM THE MARK AS SHOWN. FOR JEWELRY (U.S. CLS. 2, 27, 28 AND 50).

MATTHEW MCDOWELL, EXAMINING ATTORNEY

CLASS 14—(Continued).

SN 85-450,086. GARDENIA LTD., EATONTOWN, NJ. FILED 10-18-2011.

GARDENIA

THE MARK CONSISTS OF STANDARD CHARACTERS WITHOUT CLAIM TO ANY PARTICULAR FONT, STYLE, SIZE, OR COLOR.

FOR JEWELRY (U.S. CLS. 2, 27, 28 AND 50).
FIRST USE 11-1-2003; IN COMMERCE 11-1-2003.
BRENDAN REGAN, EXAMINING ATTORNEY

CLASS 14—(Continued).

SN 85-451,540. MEL BERNIE AND COMPANY, INC., BURBANK, CA. FILED 10-19-2011.

Love My USA

THE MARK CONSISTS OF STANDARD CHARACTERS WITHOUT CLAIM TO ANY PARTICULAR FONT, STYLE, SIZE, OR COLOR.

FOR JEWELRY (U.S. CLS. 2, 27, 28 AND 50).
BARBARA GAYNOR, EXAMINING ATTORNEY

SN 85-450,453. WELCH, KATRINA GRACE, DBA ISLAND GEMS BY KATRINA, NAPLES, FL. FILED 10-18-2011.

ISLAND GEMS

THE MARK CONSISTS OF STANDARD CHARACTERS WITHOUT CLAIM TO ANY PARTICULAR FONT, STYLE, SIZE, OR COLOR.

NO CLAIM IS MADE TO THE EXCLUSIVE RIGHT TO USE "GEMS", APART FROM THE MARK AS SHOWN.

FOR ANKLE BRACELETS; BANGLE BRACELETS; BRACELETS; BRACELETS; COSTUME JEWELRY; EAR STUDS; EARRINGS; GEMSTONE JEWELRY; JEWELRY; JEWELRY AND IMITATION JEWELRY; JEWELRY CHAINS; JEWELRY, NAMELY, ANKLETS; NECKLACES (U.S. CLS. 2, 27, 28 AND 50).

TINA MAI, EXAMINING ATTORNEY

SN 85-452,671. TWENTIETH CENTURY FOX FILM CORPORATION, LOS ANGELES, CA. FILED 10-20-2011.

CON GARRA

THE MARK CONSISTS OF STANDARD CHARACTERS WITHOUT CLAIM TO ANY PARTICULAR FONT, STYLE, SIZE, OR COLOR.

THE ENGLISH TRANSLATION OF "CON GARRA" IN THE MARK IS "PUNCHY".

FOR JEWELRY; WATCHES AND CLOCKS; WATCH BANDS AND STRAPS; ORNAMENTAL PINS (U.S. CLS. 2, 27, 28 AND 50).

JANICE L. MCMORROW, EXAMINING ATTORNEY

SN 85-451,514. LEON MINASSIAN & SONS, INC., DBA VRAM, LOS ANGELES, CA. FILED 10-19-2011.

VRAM

THE MARK CONSISTS OF A FOUR-LETTER WORD CONSISTING OF FOUR STYLIZED CAPITAL LETTERS "V R A M". THE THIRD LETTER, "A", APPEARS AS AN UPSIDE-DOWN V.

FOR JEWELRY (U.S. CLS. 2, 27, 28 AND 50).
FIRST USE 1-1-1994; IN COMMERCE 1-1-1994.

JACQUELINE A. LAVINE, EXAMINING ATTORNEY

SN 85-452,952. KINEKT DESIGN LLC, LIVINGSTON, NJ. FILED 10-21-2011.

Gear Ring

THE MARK CONSISTS OF STANDARD CHARACTERS WITHOUT CLAIM TO ANY PARTICULAR FONT, STYLE, SIZE, OR COLOR.

NO CLAIM IS MADE TO THE EXCLUSIVE RIGHT TO USE "RING", APART FROM THE MARK AS SHOWN.

FOR DIAMOND JEWELRY; GEMSTONE JEWELRY; JEWELRY; RINGS; RINGS BEING JEWELRY; WATCHES AND JEWELRY (U.S. CLS. 2, 27, 28 AND 50).

FIRST USE 5-1-2011; IN COMMERCE 5-1-2011.

ALEXANDER L. POWERS, EXAMINING ATTORNEY

CLASS 14—(Continued).

SN 85-458,703. WANDERLUSTER, LLC, NEW YORK, NY. FILED 10-28-2011.

WANDERLUSTER

THE MARK CONSISTS OF STANDARD CHARACTERS WITHOUT CLAIM TO ANY PARTICULAR FONT, STYLE, SIZE, OR COLOR.

FOR JEWELRY; HAIR JEWELRY IN THE NATURE OF JEWELRY FOR USE IN THE HAIR (U.S. CLS. 2, 27, 28 AND 50).

JOHN GARTNER, EXAMINING ATTORNEY

CLASS 14—(Continued).

SN 85-481,288. GLOBAL TRADEMARKS, INC., STOCKERTOWN, PA. FILED 11-28-2011.

FRIENDS OF TIME

THE MARK CONSISTS OF STANDARD CHARACTERS WITHOUT CLAIM TO ANY PARTICULAR FONT, STYLE, SIZE, OR COLOR.

NO CLAIM IS MADE TO THE EXCLUSIVE RIGHT TO USE "TIME", APART FROM THE MARK AS SHOWN.

FOR WATCHES (U.S. CLS. 2, 27, 28 AND 50).
CHRISTINA SOBRAL, EXAMINING ATTORNEY

SN 85-460,689. PEDRE WATCH COMPANY, INC., NEW YORK, NY. FILED 10-31-2011.



The logo for "Watch Value\$" features the words "Watch Value" in a bold, sans-serif font, followed by a large dollar sign (\$) that is stylized to look like a watch face.

NO CLAIM IS MADE TO THE EXCLUSIVE RIGHT TO USE "WATCH", APART FROM THE MARK AS SHOWN.

THE MARK CONSISTS OF A DEPICTION OF THE WORDS "WATCH" AND "VALUES" WITH A DOLLAR SIGN SUBSTITUTED FOR THE "S".

FOR WATCHES (U.S. CLS. 2, 27, 28 AND 50).
SUE LAWRENCE, EXAMINING ATTORNEY

SN 85-515,035. SUBERI BROTHERS LLC, NEW YORK, NY. FILED 1-12-2012.



The logo for "Noor" consists of the word "Noor" in a simple, clean, sans-serif font.

THE MARK CONSISTS OF STANDARD CHARACTERS WITHOUT CLAIM TO ANY PARTICULAR FONT, STYLE, SIZE, OR COLOR.

THE ENGLISH TRANSLATION OF "NOOR" IS "LIGHT". FOR DIAMOND JEWELRY; DIAMONDS (U.S. CLS. 2, 27, 28 AND 50).

FIRST USE 4-1-2004; IN COMMERCE 4-1-2004.
JAMES GRIFFIN, EXAMINING ATTORNEY

SN 85-476,443. BACK TO BUSINESS, LLC, FRANKLIN, MA. FILED 11-18-2011.



The logo for "SPORTSFANBEADS.COM" features the text "SPORTSFANBEADS.COM" in a bold, sans-serif font.

THE MARK CONSISTS OF STANDARD CHARACTERS WITHOUT CLAIM TO ANY PARTICULAR FONT, STYLE, SIZE, OR COLOR.

FOR BEADS FOR USE IN THE MANUFACTURE OF JEWELRY; BRACELETS; BRACELETS; CHARMS; EARRINGS; JEWELRY; JEWELRY CHAINS; NECKLACES; NYLON BRACELETS; PRECIOUS AND SEMI-PRECIOUS CRYSTAL STONES AND BEADS FOR USE IN JEWELRY; WOMEN'S JEWELRY (U.S. CLS. 2, 27, 28 AND 50).
MIDGE BUTLER, EXAMINING ATTORNEY

SN 85-523,959. LE SPORTSAC, INC., RENO, NV. FILED 1-24-2012.



The logo for "LeSportsac" features the word "LeSportsac" in a stylized, rounded font, enclosed within an oval shape that has a small circle on the left side, resembling a watch face.

OWNER OF U.S. REG. NOS. 1,246,478, 1,430,245 AND OTHERS.

THE MARK CONSISTS OF AN OVAL WITH THE WORDING "LESPORTSAC" INSIDE OF IT ALL IN CAPITAL LETTERS, THE LETTERS "L" AND "S" IN "LESPORTSAC" ARE IN LARGER SIZE; TO THE LEFT SIDE OF THE WORDING "LESPORTSAC" THERE APPEARS A CIRCLE; A LINE COMES OUT OF THE CIRCLE OUTLINING THE ENTIRE OVAL.

FOR WATCHES (U.S. CLS. 2, 27, 28 AND 50).
ADA HAN, EXAMINING ATTORNEY

CLASS 15—MUSICAL INSTRUMENTS

SN 85-393,882. RASHLEIGH LTD., WEST MIDLANDS CV5 6JW, UNITED KINGDOM, FILED 8-9-2011.

PBONE

THE MARK CONSISTS OF STANDARD CHARACTERS WITHOUT CLAIM TO ANY PARTICULAR FONT, STYLE, SIZE, OR COLOR.

PRIORITY CLAIMED UNDER SEC. 44(D) ON UNITED KINGDOM APPLICATION NO. 2580605, FILED 5-9-2011, REG. NO. 2580605, DATED 5-9-2011, EXPIRES 5-9-2021.

FOR MUSICAL INSTRUMENTS; MUTES, MOUTHPIECES AND STANDS FOR MUSICAL INSTRUMENTS (U.S. CLS. 2, 21 AND 36).

FIRST USE 11-1-2010; IN COMMERCE 8-7-2011.
ALLISON SCHRODY, EXAMINING ATTORNEY

SN 85-446,990. MARIO MARTIN, NASHVILLE, TN. FILED 10-13-2011.

Mario Guitars

THE MARK CONSISTS OF STANDARD CHARACTERS WITHOUT CLAIM TO ANY PARTICULAR FONT, STYLE, SIZE, OR COLOR.

NO CLAIM IS MADE TO THE EXCLUSIVE RIGHT TO USE "GUITARS", APART FROM THE MARK AS SHOWN. FOR MUSICAL INSTRUMENTS (U.S. CLS. 2, 21 AND 36).

FIRST USE 8-1-2011; IN COMMERCE 8-1-2011.
MEGHAN REINHART, EXAMINING ATTORNEY

SN 85-448,179. WOODNOTE MUSIC USA INC., EL MONTE, CA. FILED 10-14-2011.



The logo for Woodnote features the word "Woodnote" in a stylized, cursive font. The "W" is particularly large and ornate, with a flourish underneath it. The "OODNOTE" is in a simpler, sans-serif font.

THE MARK CONSISTS OF LITERAL ELEMENT "WOODNOTE" IN STYLIZED FORM WITH "W" IN EDWARDIAN SCRIPT AND "OODNOTE" IN CENTURY GOTHIC. TWO FLOURISH STROKES PLACED UNDERNEATH "DNOTE".

FOR MUSICAL INSTRUMENTS, NAMELY, PIANOS, GUITARS, ORGANS, HARMONICAS, STRINGS FOR MUSICAL INSTRUMENTS; STRING INSTRUMENTS, NAMELY, VIOLIN, VIOLA, CELLO, AND DOUBLE BASS; WOODWIND INSTRUMENTS, NAMELY, RECORDERS, SAXOPHONE, FLUTE, CLARINET, OBOE; BRASSWIND INSTRUMENT, NAMELY TRUMPET; PERCUSSION INSTRUMENTS; ELECTRONIC MUSICAL INSTRUMENTS; CASES FOR MUSICAL INSTRUMENTS; CARRYING CASES FOR MUSICAL INSTRUMENTS (U.S. CLS. 2, 21 AND 36).

FIRST USE 9-1-2011; IN COMMERCE 9-1-2011.
GRETTA YAO, EXAMINING ATTORNEY

CLASS 16—PAPER GOODS AND PRINTED MATTER

SN 76-709,570. PENTEL OF AMERICA, LTD., TORRANCE, CA. FILED 10-28-2011.



The logo for Finite! features the word "Finite!" in a bold, black, handwritten-style font. The exclamation point is large and prominent.

FOR WRITING INSTRUMENTS (U.S. CLS. 2, 5, 22, 23, 29, 37, 38 AND 50).

CHARISMA HAMPTON, EXAMINING ATTORNEY

SN 77-526,380. CURTIS, MELINDA SUE, HERMOSA BEACH, CA. FILED 7-18-2008.

Cougar Lifestyles

THE MARK CONSISTS OF STANDARD CHARACTERS WITHOUT CLAIM TO ANY PARTICULAR FONT, STYLE, SIZE, OR COLOR.

FOR MAGAZINE COLUMNS ABOUT HEALTH, FITNESS, FASHION (U.S. CLS. 2, 5, 22, 23, 29, 37, 38 AND 50).
SUE LAWRENCE, EXAMINING ATTORNEY

SN 77-615,923. IRVING TISSUE CORPORATION, DIEPPE, CANADA, FILED 11-17-2008.

HI-DRI

THE MARK CONSISTS OF STANDARD CHARACTERS WITHOUT CLAIM TO ANY PARTICULAR FONT, STYLE, SIZE, OR COLOR.

PRIORITY CLAIMED UNDER SEC. 44(D) ON CANADA APPLICATION NO. 1417330, FILED 11-6-2008, REG. NO. TMA804936, DATED 8-22-2011, EXPIRES 8-22-2026.

FOR (BASED ON INTENT TO USE) BATHROOM TISSUE, FACIAL TISSUE, AND PAPER NAPKINS; (BASED ON 44(E)) (BASED ON INTENT TO USE) PAPER TOWELS (U.S. CLS. 2, 5, 22, 23, 29, 37, 38 AND 50).

ZHALEH DELANEY, EXAMINING ATTORNEY

CLASS 16—(Continued).

SN 77-886,136. THE JOHN HENRY COMPANY, A MULTI PACKAGING SOLUTIONS COMPANY, LANSING, MI. FILED 12-4-2009.

JOURNEY

THE MARK CONSISTS OF STANDARD CHARACTERS WITHOUT CLAIM TO ANY PARTICULAR FONT, STYLE, SIZE, OR COLOR.

FOR HOLDERS FOR PLANTS AND FLOWERS, NAMELY, PAPER OR CARDBOARD OR FIBERBOARD CONTAINERS USED AS PACKAGING FOR HOLDING LIVE FLOWERS AND PLANTS DURING TRANSPORTATION (U.S. CLS. 2, 5, 22, 23, 29, 37, 38 AND 50).

WILLIAM VERHOSEK, EXAMINING ATTORNEY

SN 85-105,964. MARQUEZ BROTHERS INTERNATIONAL, INC., SAN JOSE, CA. FILED 8-12-2010.

COCINA MARQUEZ

THE MARK CONSISTS OF STANDARD CHARACTERS WITHOUT CLAIM TO ANY PARTICULAR FONT, STYLE, SIZE, OR COLOR.

OWNER OF U.S. REG. NO. 3,313,130. THE ENGLISH TRANSLATION OF "COCINA" IN THE MARK IS "KITCHEN".

FOR PRINTED RECIPES SOLD AS A COMPONENT OF FOOD PACKAGING (U.S. CLS. 2, 5, 22, 23, 29, 37, 38 AND 50).

FIRST USE 0-0-1995; IN COMMERCE 0-0-1995.
LAURA HAMMEL, EXAMINING ATTORNEY

SN 85-256,178. CARLINA, LLC, MIAMI, FL. FILED 3-2-2011.

CLEVER ENDEAVOUR

THE MARK CONSISTS OF STANDARD CHARACTERS WITHOUT CLAIM TO ANY PARTICULAR FONT, STYLE, SIZE, OR COLOR.

FOR SERIES OF CHILDREN'S BOOKS (U.S. CLS. 2, 5, 22, 23, 29, 37, 38 AND 50).

DEBRA LEE, EXAMINING ATTORNEY

CLASS 16—(Continued).

SN 85-272,365. SOULJAH STORY, INC., NEW YORK, NY. FILED 3-21-2011.

SISTER SOULJAH

THE MARK CONSISTS OF STANDARD CHARACTERS WITHOUT CLAIM TO ANY PARTICULAR FONT, STYLE, SIZE, OR COLOR.

"SISTER SOULJAH" IDENTIFIES THE STAGE NAME AND PSEUDONYM OF LISA WILLIAMSON, A LIVING INDIVIDUAL WHOSE CONSENT IS OF RECORD.

FOR PRINTED MATERIAL, NAMELY, BOOKS, MAGAZINES, STATIONERY, NEWSLETTERS IN THE FIELD OF POETRY, RAP, MUSIC AND ENTERTAINMENT, CULTURAL ISSUES, SELF IMPROVEMENT, INTER-PERSONAL RELATIONSHIPS, FAMILY, AFRICAN-AMERICAN CULTURE, COLLEGE DEGREES, GENDER ISSUES, CREATIVE WRITING, BUSINESS AND EMPLOYMENT, FINANCES, EDUCATIONAL INSTITUTIONS, SELF IMPROVEMENT, STUDENT ACTIVISM, ENTREPRENEURSHIP, DIVERSITY PROGRAMS; PRINTED EVENT PROGRAMS RELATING TO LIVE SHOWS; POSTERS; PAPER BANNERS (U.S. CLS. 2, 5, 22, 23, 29, 37, 38 AND 50).

FIRST USE 0-0-1996; IN COMMERCE 0-0-1996.
REGINA DRUMMOND, EXAMINING ATTORNEY

SN 85-294,762. MILLER ENGINEERING LLC, STAMFORD, CT. FILED 4-14-2011.



NO CLAIM IS MADE TO THE EXCLUSIVE RIGHT TO USE "MICRO STRUCTURES", APART FROM THE MARK AS SHOWN.

THE COLOR(S) GREEN, BLUE, WHITE, RED AND BLACK IS/ARE CLAIMED AS A FEATURE OF THE MARK.

THE MARK CONSISTS OF THE LITERAL ELEMENTS "MICRO STRUCTURES" WRITTEN IN RED COLOR PLACED ABOVE AN OVAL WITHIN A BLACK OVAL; THE INNER OVAL HAVING WHITE BORDER CONSISTS OF A CITY SILHOUETTE OF BUILDINGS IN BLACK COLOR WITH WHITE WINDOWS, WHEREIN THE UPPER SECTION IS BLUE THAT FADES INTO WHITE AND GREEN AT THE VERY BOTTOM ALL ON A BLACK RECTANGULAR BACKGROUND.

FOR ARCHITECTURAL MODELS, NAMELY, COMPLETED PHOTO-ETCHED BRASS ARCHITECTURAL SCALE MODELS OF COMMERCIAL AND RESIDENTIAL STRUCTURES WITH ACCOMPANYING LANDSCAPE FEATURES; AND MODEL KITS FOR ASSEMBLING SUCH ARCHITECTURAL SCALE MODELS (U.S. CLS. 2, 5, 22, 23, 29, 37, 38 AND 50).

LINDA POWELL, EXAMINING ATTORNEY

CLASS 16—(Continued).

SN 85-303,270. GROH PRODUCTIONS, INC., CHICAGO, IL.
FILED 4-25-2011.



THE MARK CONSISTS OF A CIRCLE WITH SEVEN ARROWS AROUND THE CIRCUMFERENCE POINTING AWAY FROM THE CIRCLE.

FOR BOOKS IN THE FIELD OF BUSINESS MANAGEMENT, TEAM BUILDING AND LEADERSHIP DEVELOPMENT; EDUCATIONAL PUBLICATIONS, NAMELY, TRAINING MANUALS IN THE FIELD OF BUSINESS MANAGEMENT, TEAM BUILDING AND LEADERSHIP DEVELOPMENT (U.S. CLS. 2, 5, 22, 23, 29, 37, 38 AND 50).

FIRST USE 4-0-2000; IN COMMERCE 4-0-2000.
KATHERINE E. HALMEN, EXAMINING ATTORNEY

CLASS 16—(Continued).

SN 85-324,310. HORIZON GROUP USA, INC., WARREN, NJ.
FILED 5-18-2011.

SCHOOL FX

THE MARK CONSISTS OF STANDARD CHARACTERS WITHOUT CLAIM TO ANY PARTICULAR FONT, STYLE, SIZE, OR COLOR.

NO CLAIM IS MADE TO THE EXCLUSIVE RIGHT TO USE "SCHOOL", APART FROM THE MARK AS SHOWN.

FOR BLACKBOARDS, DRAWING BOARDS AND EASELS; ART PAPER; CRAFT PAPER; COLORING BOOKS; DRAWING PADS; ARTS AND CRAFT CLAY KITS; ARTS AND CRAFT PAINT KITS; PAINT BOXES AND BRUSHES; CHILDREN'S ARTS AND CRAFTS PAPER KITS; COLORED CRAFT AND ART SAND; CRAYONS; MARKERS; PENCILS; PENS; WRITING GRIPS; HIGHLIGHTER PENS; PEN AND PENCIL CASES AND BOXES; POUCHES FOR WRITING INSTRUMENTS; PENCIL SHARPENERS; ERASERS; PAPER CLIPS; DRY ERASE WRITING BOARDS AND WRITING SURFACES; DESK SETS; STATIONERY; NOTE CARDS; ENVELOPES; NOTE PADS; ADHESIVE NOTE PADS; BLANK JOURNALS; SCRAPBOOKS; RUBBER STAMPS; STICKERS; TEMPORARY TATTOOS; NOTEBOOKS; DECORATIVE ORNAMENTS FOR PENS, PENCILS AND BINDERS (U.S. CLS. 2, 5, 22, 23, 29, 37, 38 AND 50).

REGINA DRUMMOND, EXAMINING ATTORNEY

SN 85-305,563. ALLYSON AMES COMPANY, INC., CORONA DEL MAR, CA. FILED 4-27-2011.

ALLYSON AMES

THE MARK CONSISTS OF STANDARD CHARACTERS WITHOUT CLAIM TO ANY PARTICULAR FONT, STYLE, SIZE, OR COLOR.

THE NAME "ALLYSON AMES" IDENTIFIES A LIVING INDIVIDUAL WHOSE CONSENT IS OF RECORD.

FOR PAPER AND GOODS MADE FROM PAPER, NAMELY, MAGAZINES IN THE FIELD OF BAKING, CHILDREN AND LIFESTYLE, BOOKS IN THE FIELD OF BAKING, CHILDREN AND LIFESTYLE, COMIC BOOKS, COOKBOOKS, RECIPE BOOKS, WORK BOOKS IN THE FIELD OF BAKING, CHILDREN AND LIFESTYLE, NAPKINS, TABLE CLOTHS, HATS, STREAMERS, SPECIALTY PAPER, NAMELY, PARCHMENT FOR USE IN FOOD WRAPPING, CRAFT PAPER, RIBBON, CARDS, GIFT BAGS, WRAPPING PAPER, STICKERS, GIFT TAGS, SPARKLY PAPER, GLITTER PAPER, EMBOSSED PAPER, PARTY DECORATIONS, SEASONAL PRINTED DECORATIONS, BANNERS, CAKE DECORATIONS, NOTEBOOKS, BOOK COVERS, DIARY, DECALS (U.S. CLS. 2, 5, 22, 23, 29, 37, 38 AND 50).

FIRST USE 1-1-2005; IN COMMERCE 1-1-2011.
JANICE L. MCMORROW, EXAMINING ATTORNEY

SN 85-330,504. STRONGER TODAY BRAND, LLC, BOSTON, MA. FILED 5-25-2011.

Stronger Today

THE MARK CONSISTS OF STANDARD CHARACTERS WITHOUT CLAIM TO ANY PARTICULAR FONT, STYLE, SIZE, OR COLOR.

OWNER OF U.S. REG. NOS. 3,661,593, 3,917,789 AND 3,917,844.

FOR BOOKS, MAGAZINES AND SHEET MUSIC FEATURING MOTIVATIONAL INFORMATION AND INSPIRATIONAL STORIES IN THE FIELDS OF HEALTH AND WELLNESS, EDUCATION, LOVE, SEX, FINANCE, FITNESS, SPORTS, ENTERTAINMENT, MUSIC, ART, SCIENCE, CURRENT EVENTS, HISTORY, CULTURE, NATURE, AND GOODWILL. PRINTED MATTER, PAPER AND STATIONERY PRODUCTS, PRODUCT PACKAGING, AND RELATED MATTER, NAMELY, STICKERS, BUMPER STICKERS, PINS, BUTTONS, POSTERS, POSTER BOOKS, CALENDARS, SOUVENIR PROGRAMS, NOTE CARDS, POSTCARDS, PICTURE POSTCARDS, GREETING CARDS, PRINTED GREETING CARDS WITH ELECTRONIC INFORMATION STORED THEREIN, GIFT CARDS, OCCASION CARDS, SOCIAL NOTE CARDS, MOTIVATIONAL CARDS, AFFIRMATION CARDS, CARDS BEARING UNIVERSAL GREETINGS, BLANK CARDS, BLANK NOTE CARDS, PLACE CARDS, BLANK AND PARTIALLY PRINTED

CLASS 16—(Continued).

CARDS, RECORD CARDS, SCORE CARDS, SCRAPBOOKS, STATIONERY, NOTE PADS, PAPER NOTE TABLETS, WRITING TABLETS, NOTEBOOKS, FOLDERS, FILE FOLDERS, STATIONERY FOLDERS, BOOKMARKS, BINDERS, WRITING PAPER, ENVELOPES, APPOINTMENT BOOKS, ADDRESS BOOKS, DESK PADS AND PAPER TAGS; PERSONAL ORGANIZERS, DESK TOP ORGANIZERS, ORGANIZERS FOR STATIONERY USE AND STATIONERY-TYPE PORTFOLIOS, PAPER FLAGS, MOUNTS FOR STAMPS, RUBBER STAMPS, RUBBER DOCUMENT STAMPS, STAMP PAD INKS, STAMP PADS, PAPER BANNERS, HOLDERS FOR DESK ACCESSORIES, PEN AND PENCIL CUPS, PENS, PENCILS, MARKERS, BOOK COVERS, DECALS; PHOTOGRAPH ALBUMS; PHOTOGRAPH MOUNTS; PHOTOGRAPHIC AND ART MOUNTS; PHOTOGRAPHIC PRINTS; PHOTOGRAPHS; LITHOGRAPHS; DECORATIVE PAPER CENTERPIECES; PICTURE BOOKS; PAPER AND CARDBOARD PICTURE MOUNTS; PAPER SIGN HOLDERS; CLIP BOARDS; PRINTED PAPER SIGNS (U.S. CLS. 2, 5, 22, 23, 29, 37, 38 AND 50).
CAROLINE WOOD, EXAMINING ATTORNEY

SN 85-337,438. DCWV ACQUISITION CORPORATION, PROVO, UT. FILED 6-3-2011.



OWNER OF U.S. REG. NO. 3,480,712.
THE MARK CONSISTS OF AN INK BOTTLE WITH A LARGE SQUARE DIVIDED INTO FOUR SMALLER SQUARES APPEARING ON THE FRONT AND STYLIZED CIRCULAR LINES ON THE TOP LEFT AND BOTTOM RIGHT OF THE BOTTLE. THE WORKING "INK" APPEARING TO THE RIGHT OF THE INK BOTTLE, AND A FEATHER APPEARING ABOVE THE WORKING "INK". INSIDE THE SMALL SQUARES ON THE INK BOTTLE ARE THE LETTERS "D", "C", "W" AND "V".

FOR NOTEBOOKS; BLANK JOURNALS; NOTE PADS; NOTE CARDS; ENVELOPES; PAPER; BINDERS; BINDERS FOR OFFICE USE; CLIP BOARDS; FILE FOLDERS; CONTAINERS FOR STORAGE OR TRANSPORT MADE OF PAPER OR CARDBOARD; DESKTOP ORGANIZERS; HOLDERS FOR DESK ACCESSORIES; DOCUMENT HOLDERS; LETTER TRAYS; PEN OR PENCIL HOLDERS; PHOTO ALBUMS; MAGAZINE HOLDERS COMPRISED OF PAPER AND/OR CARDBOARD; CONTAINERS FOR CARRYING OR STORING DOCUMENTS; FILE TOTES FOR CARRYING OR STORING DOCUMENTS; NOTE CARD BOXES; MEMO BOXES COMPRISED OF PAPER AND/OR CARDBOARD; BOXES COMPRISED OF PAPER AND/OR CARDBOARD FOR HOLDING PAPER OR PAPER PRODUCTS; PAPER PRODUCTS AND OFFICE SUPPLIES, NAMELY PAPER, NOTEBOOKS, HOLDERS FOR DESK ACCESSORIES, AND DOCUMENT HOLDERS, ADVERTISED VIA A WEBSITE (U.S. CLS. 2, 5, 22, 23, 29, 37, 38 AND 50).
FIRST USE 6-1-2011; IN COMMERCE 6-1-2011.

JENNY PARK, EXAMINING ATTORNEY

CLASS 16—(Continued).

SN 85-340,989. CHRISTIANS FOR ISRAEL INTERNATIONAL, NIJKERK, NETHERLANDS, FILED 6-8-2011.

CHRISTIANS FOR ISRAEL

THE MARK CONSISTS OF STANDARD CHARACTERS WITHOUT CLAIM TO ANY PARTICULAR FONT, STYLE, SIZE, OR COLOR.

SEC. 2(F).

FOR PRINTED PUBLICATIONS, NAMELY, BROCHURES, BOOKS, PAMPHLETS, REPORTS, AND NEWSLETTERS IN THE FIELDS OF INTER-RELIGIOUS DIALOGUE, CHRISTIANITY, JUDAISM, BIBLICAL PROPHECY AND HISTORY, AND A BIBLICAL UNDERSTANDING OF THE JEWISH PEOPLE (U.S. CLS. 2, 5, 22, 23, 29, 37, 38 AND 50).

FIRST USE 0-0-1998; IN COMMERCE 0-0-1998.

ADA HAN, EXAMINING ATTORNEY

SN 85-344,355. AL DUNCAN ENTERPRISES LLC, ELLENWOOD, GA. FILED 6-13-2011.

Duncan Nuggets

THE MARK CONSISTS OF STANDARD CHARACTERS WITHOUT CLAIM TO ANY PARTICULAR FONT, STYLE, SIZE, OR COLOR.

FOR BOOKS IN THE FIELD OF PERSONAL, PROFESSIONAL AND LEADERSHIP DEVELOPMENT (U.S. CLS. 2, 5, 22, 23, 29, 37, 38 AND 50).

FIRST USE 12-1-2007; IN COMMERCE 12-1-2008.

CIMMERIAN COLEMAN, EXAMINING ATTORNEY

CLASS 16—(Continued).

SN 85-356,289. WILLIAM H. TYSON, DBA STRATEGIC MARKETING PLUS, LLC, SANTA ROSA VALLEY, CA. FILED 6-25-2011.



THE COLOR(S) NAVY BLUE, OLIVE GREEN, BRICK RED AND GRAY IS/ARE CLAIMED AS A FEATURE OF THE MARK.

THE MARK CONSISTS OF AN ASCENDING BAR GRAPH WITH THREE BARS ASCENDING FROM LEFT TO RIGHT, THE LEFT BAR BEING OLIVE GREEN, THE MIDDLE BAR BEING BRICK RED, AND THE RIGHT BAR BEING OLIVE GREEN, ABOVE A NAVY BLUE ARROW APPEARING AS A ZIGZAG POINTING TO THE RIGHT, THE ARROW SHOWN ABOVE A GRAY OVAL, ALL SHOWN ABOVE THE WORDS "THE SAVVY STRATEGIST" SHOWN IN NAVY BLUE, STYLIZED CURSIVE FONT.

FOR A SERIES OF BOOKS AND WRITTEN ARTICLES IN THE FIELD OF BUSINESS; A SERIES OF BOOKS, WRITTEN ARTICLES, HANDOUTS AND WORKSHEETS IN THE FIELD OF BUSINESS (U.S. CLS. 2, 5, 22, 23, 29, 37, 38 AND 50).

ESTHER BELENKER, EXAMINING ATTORNEY

SN 85-373,357. SOLA, VICTORIA M., TEANECK, NJ. AND HUDSON, JAY, WASHINGTON, DC, DC. FILED 7-17-2011.



THE NAMES "JAY HUDSON" AND "VICKI SOLÁ" SHOWN IN THE MARK IDENTIFY LIVING INDIVIDUALS WHOSE CONSENT IS OF RECORD.

THE MARK CONSISTS OF A DOG WEARING AN OVER-SIZED T-SHIRT AND SNEAKERS COMBINED WITH THE WORDING "GNEEECEY AKA ZIG, BIZZIG, THE GRATE ONE, THE GOOD DIRECTOR (CREATED BY VICKI SOLA AND JAY HUDSON)".

FOR SERIES OF FICTION WORKS, NAMELY, NOVELS AND BOOKS (U.S. CLS. 2, 5, 22, 23, 29, 37, 38 AND 50).

KIM MONINGHOFF, EXAMINING ATTORNEY

CLASS 16—(Continued).

SN 85-388,442. CREDIT UNION NATIONAL ASSOCIATION, INC., MADISON, WI. FILED 8-3-2011.

CUNA

THE MARK CONSISTS OF STANDARD CHARACTERS WITHOUT CLAIM TO ANY PARTICULAR FONT, STYLE, SIZE, OR COLOR.

OWNER OF U.S. REG. NO. 1,243,837.

FOR PUBLICATIONS, NAMELY, BOOKS, PRINTED GUIDES, MANUALS AND NEWSLETTERS IN THE FIELD OF CREDIT UNIONS (U.S. CLS. 2, 5, 22, 23, 29, 37, 38 AND 50).

FIRST USE 8-0-1934; IN COMMERCE 8-0-1934.

ANDREA BUTLER, EXAMINING ATTORNEY

SN 85-388,707. CREDIT UNION NATIONAL ASSOCIATION, INC., MADISON, WI. FILED 8-3-2011.

CREDIT UNION NATIONAL ASSOCIATION

THE MARK CONSISTS OF STANDARD CHARACTERS WITHOUT CLAIM TO ANY PARTICULAR FONT, STYLE, SIZE, OR COLOR.

SEC. 2(F).

FOR PUBLICATIONS, NAMELY, BOOKS, PRINTED GUIDES, MANUALS AND NEWSLETTERS IN THE FIELD OF CREDIT UNIONS (U.S. CLS. 2, 5, 22, 23, 29, 37, 38 AND 50).

FIRST USE 8-0-1934; IN COMMERCE 8-0-1934.

ANDREA BUTLER, EXAMINING ATTORNEY

SN 85-396,867. AIRBRUSH ACTION, INC., ALLENWOOD, NJ. FILED 8-12-2011.

airbrush digest

THE MARK CONSISTS OF STANDARD CHARACTERS WITHOUT CLAIM TO ANY PARTICULAR FONT, STYLE, SIZE, OR COLOR.

NO CLAIM IS MADE TO THE EXCLUSIVE RIGHT TO USE "DIGEST", APART FROM THE MARK AS SHOWN.

SEC. 2(F).

FOR GENERAL FEATURE MAGAZINE IN THE FIELD OF ARTS AND CRAFTS; GENERAL FEATURE MAGAZINES (U.S. CLS. 2, 5, 22, 23, 29, 37, 38 AND 50).

FIRST USE 5-21-1981; IN COMMERCE 5-21-1981.

MICHELLE DUBOIS, EXAMINING ATTORNEY

CLASS 16—(Continued).

SN 85-417,441. HUBBARD, ROBERT W, SPRING LAKE, NC.
FILED 9-8-2011.

The Snuff Taker's Ephemeris

THE MARK CONSISTS OF STANDARD CHARACTERS WITHOUT CLAIM TO ANY PARTICULAR FONT, STYLE, SIZE, OR COLOR.

FOR GENERAL FEATURE MAGAZINE IN THE FIELD OF SMOKELESS TOBACCO (U.S. CLS. 2, 5, 22, 23, 29, 37, 38 AND 50).

FIRST USE 7-5-2010; IN COMMERCE 10-7-2010.
TINA MAI, EXAMINING ATTORNEY

CLASS 16—(Continued).

SN 85-431,162. BUCKET FILLERS, INC., BRIGHTON, MI.
FILED 9-24-2011.

Have You Filled a Bucket Today?

THE MARK CONSISTS OF STANDARD CHARACTERS WITHOUT CLAIM TO ANY PARTICULAR FONT, STYLE, SIZE, OR COLOR.

OWNER OF U.S. REG. NO. 3,907,858.
FOR POSTERS (U.S. CLS. 2, 5, 22, 23, 29, 37, 38 AND 50).

FIRST USE 10-13-2005; IN COMMERCE 6-13-2006.
ANDREW LEASER, EXAMINING ATTORNEY

SN 85-418,455. EVANS, THOMAS, PITTSBURG, CA. FILED 9-9-2011.

stuntride

THE MARK CONSISTS OF STANDARD CHARACTERS WITHOUT CLAIM TO ANY PARTICULAR FONT, STYLE, SIZE, OR COLOR.

SEC. 2(F).
FOR MAGAZINES FEATURING THE SUBJECT OF MOTORCYCLE STUNT RIDING (U.S. CLS. 2, 5, 22, 23, 29, 37, 38 AND 50).

FIRST USE 1-0-2005; IN COMMERCE 1-0-2005.
CHRISTOPHER LAW, EXAMINING ATTORNEY

SN 85-434,478. ROURKE, JACK, LOS ANGELES, CA. FILED 9-28-2011.

The Rational Psychic

THE MARK CONSISTS OF STANDARD CHARACTERS WITHOUT CLAIM TO ANY PARTICULAR FONT, STYLE, SIZE, OR COLOR.

NO CLAIM IS MADE TO THE EXCLUSIVE RIGHT TO USE "PSYCHIC", APART FROM THE MARK AS SHOWN.
FOR BOOKS IN THE FIELD OF PARAPSYCHOLOGY, SPIRITUALITY, AND SELF HELP (U.S. CLS. 2, 5, 22, 23, 29, 37, 38 AND 50).

DAWN HAN, EXAMINING ATTORNEY

SN 85-422,595. GLORIA BANG, DBA PEAR OF HEARTS, NORTH ARLINGTON, NJ. FILED 9-14-2011.

Pear of Hearts

THE MARK CONSISTS OF WORDS SPELLING OUT "PEAR OF HEARTS" USING GIORGIO FONT.

FOR ANNOUNCEMENT CARDS; CORRESPONDENCE CARDS; GREETING CARDS; POSTCARDS; HOLIDAY CARDS; INVITATION CARDS; OCCASION CARDS; PRINTED INVITATIONS (U.S. CLS. 2, 5, 22, 23, 29, 37, 38 AND 50).

LESLEY LAMOTHE, EXAMINING ATTORNEY

SN 85-435,897. KENNEDY, JOHN, REDONDO BEACH, CA. FILED 9-29-2011.

5 for 1 Diet

THE MARK CONSISTS OF STANDARD CHARACTERS WITHOUT CLAIM TO ANY PARTICULAR FONT, STYLE, SIZE, OR COLOR.

NO CLAIM IS MADE TO THE EXCLUSIVE RIGHT TO USE "DIET", APART FROM THE MARK AS SHOWN.

FOR BOOKS IN THE FIELD OF HEART HEALTH (U.S. CLS. 2, 5, 22, 23, 29, 37, 38 AND 50).

MARIA-VICTORIA SUAREZ, EXAMINING ATTORNEY

CLASS 16—(Continued).

SN 85-439,595. DOROTHY GILSTRAP, ARLINGTON, TX. FILED 10-5-2011.

You Have Enemies

THE MARK CONSISTS OF STANDARD CHARACTERS WITHOUT CLAIM TO ANY PARTICULAR FONT, STYLE, SIZE, OR COLOR.

FOR A SERIES OF BOOKS, WRITTEN ARTICLES, HANDOUTS AND WORKSHEETS IN THE FIELD OF HEALTH (U.S. CLS. 2, 5, 22, 23, 29, 37, 38 AND 50).

PAUL E. FAHRENKOPF, EXAMINING ATTORNEY

SN 85-440,533. SUGARMADE, INC., SAN JOSE, CA. FILED 10-6-2011.

HARVEST A BRIGHTER FUTURE

THE MARK CONSISTS OF STANDARD CHARACTERS WITHOUT CLAIM TO ANY PARTICULAR FONT, STYLE, SIZE, OR COLOR.

FOR PAPER AND CARDBOARD (U.S. CLS. 2, 5, 22, 23, 29, 37, 38 AND 50).

FIRST USE 8-19-2011; IN COMMERCE 8-19-2011.

JOHN DWYER, EXAMINING ATTORNEY

SN 85-442,557. FASTLANEMX, VISTA, CA. FILED 10-7-2011.

FastlaneMX

THE MARK CONSISTS OF STANDARD CHARACTERS WITHOUT CLAIM TO ANY PARTICULAR FONT, STYLE, SIZE, OR COLOR.

FOR KITS CONTAINING STICKERS WITH DECORATIVE NUMBERS AND DESIGNS FOR USERS TO PLACES ON BODY PANELS OF MOTORCYCLES, ATVS, RACE CARS, TRAILERS, TRUCKS, VANS, HELMETS, AND CLOTHING (U.S. CLS. 2, 5, 22, 23, 29, 37, 38 AND 50).

FIRST USE 1-1-1983; IN COMMERCE 1-3-2008.

AISHA CLARKE, EXAMINING ATTORNEY

CLASS 16—(Continued).

SN 85-442,597. I.R.A. PUBLISHING INC, DBA MYAUTOPLUS.COM, LOS ANGELES, CA. FILED 10-7-2011.



OWNER OF U.S. REG. NO. 3,474,779.

THE COLOR(S) ORANGE, BLACK AND WHITE IS/ARE CLAIMED AS A FEATURE OF THE MARK.

THE MARK CONSISTS OF THE STYLIZED WORDING "MYAUTOPLUS.COM" WITH THE TERMS "MY" AND "PLUS.COM" IN ORANGE AND THE TERM "AUTO" IN WHITE, WITH THE WORDING SURROUNDED BY BLACK BORDERING.

FOR MAGAZINES FEATURING CAR ADVERTISING (U.S. CLS. 2, 5, 22, 23, 29, 37, 38 AND 50).

FIRST USE 1-1-2001; IN COMMERCE 1-1-2011.

DOUGLAS LEE, EXAMINING ATTORNEY

SN 85-444,561. C. DANA EVANS, DBA TWIN STAR, WALTHAM, MA. FILED 10-11-2011.



THE MARK CONSISTS OF THE WORDING "TWIN STAR" ABOVE A FIVE POINTED STAR JOINED WITH A SIX POINTED STAR.

SEC. 2(F).

FOR A SERIES OF BOOKS, WRITTEN ARTICLES, HANDOUTS AND WORKSHEETS IN THE FIELD OF MUSIC, ART, COMMUNITY; EDUCATIONAL PUBLICATIONS, NAMELY, EDUCATIONAL LEARNING CARDS, FLASH CARDS, ACTIVITY CARDS, WORKBOOKS, TEXTBOOKS, ACTIVITY BOOKS, STORY BOOKS, PUZZLE BOOKS, PRINTED PUZZLES, TEACHER GUIDES, MANUALS, POSTERS AND EDUCATIONAL BOOKLETS IN THE FIELD OF ART, MUSIC, COMMUNITY, DRUMMING; EDUCATIONAL PUBLICATIONS, NAMELY, CURRICULUM, ARTICLES, JOURNAL, CATALOG IN THE FIELDS OF ART; NON-FICTION BOOKS ON A VARIETY OF TOPICS (U.S. CLS. 2, 5, 22, 23, 29, 37, 38 AND 50).

FIRST USE 4-22-1995; IN COMMERCE 9-30-1999.

JOHN DWYER, EXAMINING ATTORNEY

CLASS 16—(Continued).

SN 85-445,375. SOUTHERN TRAVEL TOURISM ASSOCIATION, INC., BREWTON, AL. FILED 10-12-2011.

Southern Travel

THE MARK CONSISTS OF STANDARD CHARACTERS WITHOUT CLAIM TO ANY PARTICULAR FONT, STYLE, SIZE, OR COLOR.

NO CLAIM IS MADE TO THE EXCLUSIVE RIGHT TO USE "TRAVEL", APART FROM THE MARK AS SHOWN.

FOR MAGAZINES FEATURING TOURIST, SHOPPING, AND TRAVEL ATTRACTIONS; MAGAZINES IN THE FIELD OF TOURIST, SHOPPING, AND TRAVEL ATTRACTIONS; PUBLICATIONS, NAMELY, MAGAZINES IN THE FIELDS OF TOURIST, SHOPPING, AND TRAVEL ATTRACTIONS (U.S. CLS. 2, 5, 22, 23, 29, 37, 38 AND 50).

DAVID C. REIHNER, EXAMINING ATTORNEY

SN 85-445,418. CONTINUITY PUBLISHING, INC., BELLINGHAM, WA. FILED 10-12-2011.

RETAILING INSIGHT

THE MARK CONSISTS OF STANDARD CHARACTERS WITHOUT CLAIM TO ANY PARTICULAR FONT, STYLE, SIZE, OR COLOR.

NO CLAIM IS MADE TO THE EXCLUSIVE RIGHT TO USE "RETAILING", APART FROM THE MARK AS SHOWN.

FOR MAGAZINES FEATURING BUSINESS ADVICE, NEWS AND TRENDS, PRODUCT REVIEWS AND INFORMATION, AND ADVERTISING FOR RETAILERS IN THE BODY, MIND AND SPIRIT INDUSTRY (U.S. CLS. 2, 5, 22, 23, 29, 37, 38 AND 50).

ERIN FALK, EXAMINING ATTORNEY

SN 85-445,503. CARRA L. RILEY, P.C., DBA CARRA RILEY, INC., WILLIAMS, AZ. FILED 10-12-2011.

Cosmic Cow Pie

THE MARK CONSISTS OF STANDARD CHARACTERS WITHOUT CLAIM TO ANY PARTICULAR FONT, STYLE, SIZE, OR COLOR.

FOR A SERIES OF BOOKS, WRITTEN ARTICLES, HANDOUTS AND WORKSHEETS IN THE FIELD OF STRESS MANAGEMENT AND INSPIRATION (U.S. CLS. 2, 5, 22, 23, 29, 37, 38 AND 50).

FIRST USE 1-28-2009; IN COMMERCE 1-28-2009.

LINDA E. BLOHM, EXAMINING ATTORNEY

CLASS 16—(Continued).

SN 85-446,356. RAINES, BRUCE R., NEW CITY, NY. FILED 10-13-2011.

JOHNNIE WINE CLUB

THE MARK CONSISTS OF STANDARD CHARACTERS WITHOUT CLAIM TO ANY PARTICULAR FONT, STYLE, SIZE, OR COLOR.

NO CLAIM IS MADE TO THE EXCLUSIVE RIGHT TO USE "WINE CLUB", APART FROM THE MARK AS SHOWN.

FOR NOTE CARDS FEATURING WINE RECOMMENDATIONS (U.S. CLS. 2, 5, 22, 23, 29, 37, 38 AND 50).

FIRST USE 12-3-2010; IN COMMERCE 12-3-2010.

IRA J. GOODSАID, EXAMINING ATTORNEY

SN 85-446,699. BBD DESIGN, LLC, GLEN ALLEN, VA. FILED 10-13-2011.



NO CLAIM IS MADE TO THE EXCLUSIVE RIGHT TO USE "DOGS", APART FROM THE MARK AS SHOWN.

THE COLOR(S) BLUE, ORANGE, GRAY, BLACK, AND WHITE IS/ARE CLAIMED AS A FEATURE OF THE MARK.

THE MARK CONSISTS OF THE STYLIZED WORDING "DO DAD DOGS". "DO" APPEARS IN WHITE, SUPERIMPOSED ON A BLUE DIAMOND-SHAPED DOG TAG WITH A WHITE CIRCLE AT THE TOP AND A WHITE GRADIENT PATTERN ON THE BOTTOM. "DAD" APPEARS IN WHITE, SUPERIMPOSED ON AN ORANGE CIRCULAR DOG TAG, WITH A WHITE CIRCLE AT THE TOP AND A WHITE GRADIENT PATTERN ON THE BOTTOM. "DOGS" APPEARS IN ORANGE, WITH TWO GRAY LINES AND TWO BLACK LINES DEPICTING MOTION SURROUNDING THE BOTTOM OF THE LETTER "G".

FOR ART PRINTS COMPRISED OF DIGITAL ILLUSTRATIONS ORIGINATING FROM PHOTOGRAPHS; FRAMED ART PRINTS; GRAPHIC ART PRINTS; GREETING CARDS; GREETINGS CARDS AND POST-CARDS; NOTE CARDS; PHOTOGRAPHIC PRINTS (U.S. CLS. 2, 5, 22, 23, 29, 37, 38 AND 50).

FIRST USE 4-8-2008; IN COMMERCE 3-26-2009.

LIEF MARTIN, EXAMINING ATTORNEY

CLASS 16—(Continued).

SN 85-447,173. SKULLCANDY, INC., PARK CITY, UT.
FILED 10-13-2011.



THE MARK CONSISTS OF REVERSE IMAGE OF A SKULL.

FOR POSTCARDS AND GREETING CARDS; POSTERS; PRINTS; STENCILS; STICKERS (U.S. CLS. 2, 5, 22, 23, 29, 37, 38 AND 50).

FONG HSU, EXAMINING ATTORNEY

SN 85-447,177. SKULLCANDY, INC., PARK CITY, UT.
FILED 10-13-2011.

SKULLCANDY

THE MARK CONSISTS OF STANDARD CHARACTERS WITHOUT CLAIM TO ANY PARTICULAR FONT, STYLE, SIZE, OR COLOR.

OWNER OF U.S. REG. NOS. 3,168,695, 3,726,304 AND OTHERS.

FOR POSTCARDS AND GREETING CARDS; POSTERS; PRINTS; STENCILS; STICKERS (U.S. CLS. 2, 5, 22, 23, 29, 37, 38 AND 50).

FONG HSU, EXAMINING ATTORNEY

SN 85-447,373. KIMBERLY-CLARK WORLDWIDE, INC.,
NEENAH, WI. FILED 10-14-2011.

KEEP IT CLEAN

THE MARK CONSISTS OF STANDARD CHARACTERS WITHOUT CLAIM TO ANY PARTICULAR FONT, STYLE, SIZE, OR COLOR.

FOR DISPOSABLE PAPER HAND-TOWELS (U.S. CLS. 2, 5, 22, 23, 29, 37, 38 AND 50).

TASNEEM HUSSAIN, EXAMINING ATTORNEY

CLASS 16—(Continued).

SN 85-447,407. RAG DOLL MERCHANDISING, INC.,
WOODLAND HILLS, CA. FILED 10-14-2011.

AEROSMITH'S BLUE ARMY

THE MARK CONSISTS OF STANDARD CHARACTERS WITHOUT CLAIM TO ANY PARTICULAR FONT, STYLE, SIZE, OR COLOR.

OWNER OF U.S. REG. NOS. 1,552,802, 2,954,199 AND 3,224,353.

FOR PAPER GOODS AND PRINTED MATTER, NAMELY, BOOKS IN THE FIELD OF MUSIC AND ENTERTAINMENT, SERIES OF FICTION BOOKS; COMIC BOOKS, BUMPER STICKERS, STICKERS, CALENDARS, PENCIL SHARPENERS, PENCIL CASES, ACTIVITY BOOKS, BOTH PRINTED AND BLANK; BINDERS, NOTEBOOKS, STATIONERY, NOTE PADS, WRITING TABLETS, PAPER TABLE CLOTHS, PAPER NAPKINS, PENCILS, MARKERS, ERASERS, COLORING BOOKS, WRITING PENS, NON-CALIBRATED RULERS, PAPER WEIGHTS, PAPER COASTERS, BOOKMARKS, BOOK COVERS AND HOLDERS, PAPER PLACE MATS; PHOTO ALBUMS; ADDRESS BOOKS; FAN CLUB NEWSLETTERS, POST CARDS, HOLIDAY CARDS, GREETING CARDS, ART PRINTS, PRINTED ART REPRODUCTIONS, POSTERS, MERCHANDISE BAGS; CHILDREN'S BOOKS; CHILDREN'S ACTIVITY BOOKS AND PICTURE BOOKS; PHOTOGRAPHS, GIFT WRAP PAPER; ENTERTAINMENT TOUR MEMORABILIA COLLECTION BOOKS; EVENT PROGRAMS; SONG BOOKS; SHEET MUSIC BOOKS; PICTURE BOOKS; DECALS; MAGAZINES, NEWSLETTERS, BOOKLETS, PAMPHLETS AND BROCHURES IN THE FIELD OF MUSIC AND ENTERTAINMENT; LITHOGRAPHS; PRECIOUS METAL MONEY CLIPS; LETTER OPENERS OF PRECIOUS METAL AND BOOK MARKERS OF PRECIOUS METAL (U.S. CLS. 2, 5, 22, 23, 29, 37, 38 AND 50).

BRIAN PINO, EXAMINING ATTORNEY

SN 85-447,421. CHECKADVANTAGE, LLC, APPLETON, WI.
FILED 10-14-2011.

CHECKADVANTAGE

THE MARK CONSISTS OF STANDARD CHARACTERS WITHOUT CLAIM TO ANY PARTICULAR FONT, STYLE, SIZE, OR COLOR.

FOR BANK CHECKS (U.S. CLS. 2, 5, 22, 23, 29, 37, 38 AND 50).

FIRST USE 4-2-2002; IN COMMERCE 4-2-2002.

FRED CARL, EXAMINING ATTORNEY

CLASS 16—(Continued).

SN 85-447,427. CHECKADVANTAGE, LLC, APPLETON, WI. FILED 10-14-2011.



The logo for CheckADVANTAGE features the word "Check" in a bold, sans-serif font, followed by "ADVANTAGE" in a larger, bold, sans-serif font. A checkmark is drawn over the "A" in "ADVANTAGE".

THE MARK CONSISTS OF THE WORD "CHECKADVANTAGE" WITH A CHECKMARK ACROSS THE FIRST "A" IN THE WORD "ADVANTAGE".

FOR BANK CHECKS (U.S. CLS. 2, 5, 22, 23, 29, 37, 38 AND 50).

FIRST USE 4-2-2002; IN COMMERCE 4-2-2002.
FRED CARL, EXAMINING ATTORNEY

SN 85-447,508. THE ARISTOTLE CORPORATION, STAMFORD, CT. FILED 10-14-2011.

ARTASTIC

THE MARK CONSISTS OF STANDARD CHARACTERS WITHOUT CLAIM TO ANY PARTICULAR FONT, STYLE, SIZE, OR COLOR.

FOR ART PADS, ART PAPER, DRAWING PADS, DRAWING PAPER, SKETCH BOOKS, SKETCH PADS, DRAWING PENCILS, ERASERS (U.S. CLS. 2, 5, 22, 23, 29, 37, 38 AND 50).

LINDA ESTRADA, EXAMINING ATTORNEY

SN 85-447,522. GREATER MIAMI BASEBALL CLUB, L.P., FORT MYERS, FL. FILED 10-14-2011.



OWNER OF U.S. REG. NO. 2,588,594.
NO CLAIM IS MADE TO THE EXCLUSIVE RIGHT TO USE "FORT MYERS", APART FROM THE MARK AS SHOWN.

THE MARK CONSISTS OF A BODY OF WATER WITH A SAILBOAT SAILING TOWARDS A BEACH WITH "FORT MYERS MIRACLE" ABOVE WITH A PALM TREE AND BASEBALL INCORPORATED INTO THE WORDING.

FOR PAPER GOODS AND PRINTED MATTER, NAMELY AUTOGRAPH BOOKS, BINDERS, BOOKMARKS, BUMPER STICKERS, CALENDARS, CATALOGS IN THE FIELD OF BASEBALL, DECALS, MERCHANDISE BAGS, NEWSLETTERS IN THE FIELD OF BASEBALL, NOTE PADS, PAPER PENNANTS, PAPER GAME SCHEDULES, PENS, PENCILS, POSTCARDS, POSTERS, PRINTED AWARDS, PRINTED GAME TICKETS, PRINTED GUIDES IN THE FIELD OF BASEBALL, REFERENCE BOOKS IN THE FIELD OF BASEBALL, SCORE BOOKS, SCORE CARDS, SCORE SHEETS, STATIONERY, STICKERS, STICKER ALBUMS AND TRADING CARDS (U.S. CLS. 2, 5, 22, 23, 29, 37, 38 AND 50).

FIRST USE 10-1-2011; IN COMMERCE 10-1-2011.
EMILY CARLSEN, EXAMINING ATTORNEY

CLASS 16—(Continued).

SN 85-447,533. WELTER, HERB, LINCOLN, NE. FILED 10-14-2011.

SALVATION HAPPENS

THE MARK CONSISTS OF STANDARD CHARACTERS WITHOUT CLAIM TO ANY PARTICULAR FONT, STYLE, SIZE, OR COLOR.

FOR BUMPER STICKERS (U.S. CLS. 2, 5, 22, 23, 29, 37, 38 AND 50).

MIDGE BUTLER, EXAMINING ATTORNEY

SN 85-447,545. RAG DOLL MERCHANDISING, INC., WOODLAND HILLS, CA. FILED 10-14-2011.

THE BLUE ARMY

THE MARK CONSISTS OF STANDARD CHARACTERS WITHOUT CLAIM TO ANY PARTICULAR FONT, STYLE, SIZE, OR COLOR.

FOR PAPER GOODS AND PRINTED MATTER, NAMELY, BOOKS IN THE FIELD OF MUSIC AND ENTERTAINMENT, SERIES OF FICTION BOOKS; COMIC BOOKS, BUMPER STICKERS, STICKERS, CALENDARS, PENCIL SHARPENERS, PENCIL CASES, ACTIVITY BOOKS, BOTH PRINTED AND BLANK; BINDERS, NOTEBOOKS, STATIONERY, NOTE PADS, WRITING TABLETS, PAPER TABLE CLOTHS, PAPER NAPKINS, PENCILS, MARKERS, ERASERS, COLORING BOOKS, WRITING PENS, NON-CALIBRATED RULERS, PAPER WEIGHTS, PAPER COASTERS, BOOKMARKS, BOOK COVERS AND HOLDERS, PAPER PLACE MATS; PHOTO ALBUMS; ADDRESS BOOKS; FAN CLUB NEWSLETTERS, POST CARDS, HOLIDAY CARDS, GREETING CARDS, ART PRINTS, PRINTED ART REPRODUCTIONS, POSTERS, MERCHANDISE BAGS; CHILDREN'S BOOKS; CHILDREN'S ACTIVITY BOOKS AND PICTURE BOOKS; PHOTOGRAPHS, GIFT WRAP PAPER; ENTERTAINMENT TOUR MEMORABILIA COLLECTION BOOKS; EVENT PROGRAMS; SONG BOOKS; SHEET MUSIC BOOKS; PICTURE BOOKS; DECALS; MAGAZINES, NEWSLETTERS, BOOKLETS, PAMPHLETS AND BROCHURES IN THE FIELD OF MUSIC AND ENTERTAINMENT; LITHOGRAPHS; PRECIOUS METAL MONEY CLIPS; LETTER OPENERS OF PRECIOUS METAL AND BOOK MARKERS OF PRECIOUS METAL (U.S. CLS. 2, 5, 22, 23, 29, 37, 38 AND 50).

BRIAN PINO, EXAMINING ATTORNEY

CLASS 16—(Continued).

SN 85-447,719. STERLING PUBLISHING CO., INC., NEW YORK, NY. FILED 10-14-2011.

LITTLE STERLING STORIES

THE MARK CONSISTS OF STANDARD CHARACTERS WITHOUT CLAIM TO ANY PARTICULAR FONT, STYLE, SIZE, OR COLOR.

OWNER OF U.S. REG. NOS. 3,280,855, 3,837,927 AND OTHERS.

NO CLAIM IS MADE TO THE EXCLUSIVE RIGHT TO USE "STORIES", APART FROM THE MARK AS SHOWN.

FOR A SERIES OF CHILDREN'S BOOKS (U.S. CLS. 2, 5, 22, 23, 29, 37, 38 AND 50).

ANDREW LEASER, EXAMINING ATTORNEY

SN 85-447,759. PRINT ART, INC, EGG HARBOR TOWNSHIP, NJ. FILED 10-14-2011.

THINKBOOK

THE MARK CONSISTS OF STANDARD CHARACTERS WITHOUT CLAIM TO ANY PARTICULAR FONT, STYLE, SIZE, OR COLOR.

FOR ART PADS; BLANK JOURNAL BOOKS; BLANK JOURNALS; BLANK PAPER NOTEBOOKS; BLANK WRITING JOURNALS; CALENDARS AND DIARIES; CUSTOMIZABLE JOURNAL BOOKS; DESK PADS; DIARIES; DRAWING PADS; MEMO PADS; NOTE PAD HOLDERS; NOTE PADS; NOTEBOOK COVERS; NOTEBOOKS; PAPER NOTEBOOKS; PERSONALIZED WRITING JOURNALS; SCRAPBOOK ALBUMS; SCRAPBOOKS; SCRATCH PADS; SCRIBBLE PADS; SKETCH PADS; SKETCHBOOKS; SPIRAL-BOUND NOTEBOOKS; STAMP PADS; WIRE-BOUND NOTEBOOKS; WRITING JOURNAL SHEETS; WRITING PADS; WRITING PAPER; WRITING PAPER HOLDERS; WRITING PAPER PADS; WRITING TABLETS (U.S. CLS. 2, 5, 22, 23, 29, 37, 38 AND 50).

FIRST USE 3-10-2011; IN COMMERCE 3-10-2011.
TOBY BULLOFF, EXAMINING ATTORNEY

SN 85-447,791. FAT AS MY DAD, LLC, JACKSONVILLE, FL. FILED 10-14-2011.

FAT AS MY DAD

THE MARK CONSISTS OF STANDARD CHARACTERS WITHOUT CLAIM TO ANY PARTICULAR FONT, STYLE, SIZE, OR COLOR.

FOR PUBLICATIONS, NAMELY, BOOKS IN THE FIELDS OF WEIGHT LOSS, FITNESS AND HEALTH (U.S. CLS. 2, 5, 22, 23, 29, 37, 38 AND 50).

DAVID YONTEF, EXAMINING ATTORNEY

CLASS 16—(Continued).

SN 85-447,910. MOORE, JOHN, SWANSBORO, NC. FILED 10-14-2011.

Hook and Bones

THE MARK CONSISTS OF STANDARD CHARACTERS WITHOUT CLAIM TO ANY PARTICULAR FONT, STYLE, SIZE, OR COLOR.

FOR DECALS (U.S. CLS. 2, 5, 22, 23, 29, 37, 38 AND 50).

LEIGH CAROLINE CASE, EXAMINING ATTORNEY

SN 85-447,919. ELECTRONIC IMAGING SERVICES, INC., DBA VESTCOM RETAIL SOLUTIONS, LITTLE ROCK, AR. FILED 10-14-2011.

AisleWise

THE MARK CONSISTS OF STANDARD CHARACTERS WITHOUT CLAIM TO ANY PARTICULAR FONT, STYLE, SIZE, OR COLOR.

FOR PRINTED PAPER LABELS AND PRINTED PAPER IN-STORE DISPLAY SIGNS FEATURING PRODUCT PRICING AND PRODUCT ADVERTISING INFORMATION; PRINTED LABELS NOT OF TEXTILE; PRINTED CARDS, NAMELY, POINT-OF-PURCHASE DISPLAY CARDS MADE OF PRESSURE-SENSITIVE MATERIALS; PRINTED PAPER SIGNS; ADHESIVE BACKED PRINTED LABELS; PAPER CARD STOCK FOR SIGNAGE, LABELS, AND TAGS; PRINTED PAPER LABELS; PRINTED LABELS FOR USE AT RETAIL STORES AS A NON-PRESSURE SENSITIVE TAG WHERE CO-EXTRUDER HOLDERS AND MOLDINGS ARE USED (U.S. CLS. 2, 5, 22, 23, 29, 37, 38 AND 50).

RONALD MCMORROW, EXAMINING ATTORNEY

SN 85-448,638. PATTERSON, LUKE D., DBA KINETIC ACUITY LLC, COLUMBIA, MO. FILED 10-17-2011.

11 in 11

THE MARK CONSISTS OF STANDARD CHARACTERS WITHOUT CLAIM TO ANY PARTICULAR FONT, STYLE, SIZE, OR COLOR.

FOR BUMPER STICKERS (U.S. CLS. 2, 5, 22, 23, 29, 37, 38 AND 50).

CHRIS WELLS, EXAMINING ATTORNEY

CLASS 16—(Continued).

SN 85-448,775. HAATVEDT, LESLIE, VERO BEACH, FL.
FILED 10-17-2011.



NO CLAIM IS MADE TO THE EXCLUSIVE RIGHT TO USE "PROGRAM", APART FROM THE MARK AS SHOWN. THE STIPPLING IS FOR SHADING PURPOSES ONLY.

THE MARK CONSISTS OF A ROUND CIRCLE WITH A SQUARE INSIDE OF IT. INSIDE THE SQUARE IS A STAR ON A RIBBON. ABOVE THE SQUARE, INSIDE THE CIRCLE, IS THE WORD "THE" AND UNDER IS THE STYLIZED TEXT "H.E.R.O." OUTSIDE THE LARGE CIRCLE IS THE STYLIZED TEXT "PROGRAM".

FOR PRINTED TEACHERS GUIDES IN THE FIELD OF ANTIBULLYING TECHNIQUES, CONNECTING STUDENTS TO THEIR INNER HERO OR HIGHER SELF, DEVELOPING A MORAL COMPASS, BEING ASSERTIVE, BULLY-PROOFING YOURSELF, CONFLICT RESOLUTION, AND MAKING WISE CHOICES (U.S. CLS. 2, 5, 22, 23, 29, 37, 38 AND 50).

JAMES LOVELACE, EXAMINING ATTORNEY

SN 85-448,785. LIBERTY TREE PRESS, LLC, SANDY, UT.
FILED 10-17-2011.

LIBERTY TREE PRESS

THE MARK CONSISTS OF STANDARD CHARACTERS WITHOUT CLAIM TO ANY PARTICULAR FONT, STYLE, SIZE, OR COLOR.

NO CLAIM IS MADE TO THE EXCLUSIVE RIGHT TO USE "PRESS", APART FROM THE MARK AS SHOWN.

FOR GENERAL FEATURE MAGAZINES (U.S. CLS. 2, 5, 22, 23, 29, 37, 38 AND 50).

FIRST USE 1-0-2009; IN COMMERCE 1-0-2009.

JOHN HWANG, EXAMINING ATTORNEY

CLASS 16—(Continued).

SN 85-449,050. GRAFCOR PACKAGING INC., ROCKFORD, IL. FILED 10-17-2011.

BOTTOMS UP

THE MARK CONSISTS OF STANDARD CHARACTERS WITHOUT CLAIM TO ANY PARTICULAR FONT, STYLE, SIZE, OR COLOR.

FOR CARDBOARD PACKAGING CONTAINERS FOR SHIPPING FRAGILE ARTICLES (U.S. CLS. 2, 5, 22, 23, 29, 37, 38 AND 50).

DORITT L. CARROLL, EXAMINING ATTORNEY

SN 85-449,084. LOEW-CORNELL, LLC, ERLANGER, KY.
FILED 10-17-2011.

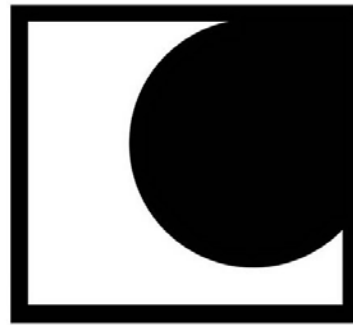

OWNER OF U.S. REG. NO. 4,072,694.

THE MARK CONSISTS OF A SQUARE WITH A PORTION OF A CIRCLE EXTENDING FROM THE UPPER RIGHT HAND CORNER OF THE SQUARE TOWARDS THE CENTER OF THE SQUARE.

FOR ARTISTS SUPPLIES, NAMELY, PAINT BRUSHES (U.S. CLS. 2, 5, 22, 23, 29, 37, 38 AND 50).

JESSICA FATHY, EXAMINING ATTORNEY

SN 85-449,235. SHANGRILOO TALES, INC., SCOTTSDALE, AZ. FILED 10-17-2011.

Shangriloo

THE MARK CONSISTS OF STANDARD CHARACTERS WITHOUT CLAIM TO ANY PARTICULAR FONT, STYLE, SIZE, OR COLOR.

FOR CHILDREN'S BOOKS; CHILDREN'S INTERACTIVE EDUCATIONAL BOOKS; CHILDREN'S STORYBOOKS; CHILDREN'S WALL STICKERS AND MURALS; COLORING BOOKS; PRINTED CHILDREN'S COLORING PAGES; STORY BOOKS; TALKING CHILDREN'S BOOKS (U.S. CLS. 2, 5, 22, 23, 29, 37, 38 AND 50).

ROBERT C. CLARK JR., EXAMINING ATTORNEY

CLASS 16—(Continued).

SN 85-449,443. HANGZHOU PROSTAR ENTERPRISES LTD.,
HANGZHOU, ZHEJIANG, CHINA, FILED 10-18-2011.



THE COLOR(S) BLUE AND WHITE IS/ARE CLAIMED AS
A FEATURE OF THE MARK.

THE MARK CONSISTS OF THE STYLIZED WORD
"PROSTAR" IN WHITE WITH A WHITE FIVE POINTED
STAR AT THE TOP OF THE LETTER A, ALL ON A BLUE
RECTANGLE BACKGROUND.

THE WORDING "PROSTAR" HAS NO MEANING IN A
FOREIGN LANGUAGE.

FOR CRAYONS; MECHANICAL PENCILS; NOTE
BOOKS; PAPER; PEN NIBS; PENCIL SHARPENERS;
PENCILS; STATIONERY; STEEL PENS; WRITING IN-
STRUMENTS (U.S. CLS. 2, 5, 22, 23, 29, 37, 38 AND 50).

FIRST USE 3-14-2009; IN COMMERCE 10-8-2009.
ELISSA GARBER KON, EXAMINING ATTORNEY

SN 85-449,463. JOHN P. NISSEN JR. COMPANY, GLENSIDE,
PA. FILED 10-18-2011.

WYN-COTE

THE MARK CONSISTS OF STANDARD CHARACTERS
WITHOUT CLAIM TO ANY PARTICULAR FONT, STYLE,
SIZE, OR COLOR.

FOR MARKERS (U.S. CLS. 2, 5, 22, 23, 29, 37, 38 AND
50).

KATHERINE STOIDES, EXAMINING ATTORNEY

SN 85-449,676. FOREMAN-ALONSO.MELANIE L, DBA
REAL HUNTERS, WESTON, FL. FILED 10-18-2011.

REAL HUNTERS

THE MARK CONSISTS OF STANDARD CHARACTERS
WITHOUT CLAIM TO ANY PARTICULAR FONT, STYLE,
SIZE, OR COLOR.

FOR BUMPER STICKERS (U.S. CLS. 2, 5, 22, 23, 29, 37,
38 AND 50).

MICHAEL KEATING, EXAMINING ATTORNEY

CLASS 16—(Continued).

SN 85-449,781. DIXIE CONSUMER PRODUCTS LLC,
ATLANTA, GA. FILED 10-18-2011.

ECOSMART

THE MARK CONSISTS OF STANDARD CHARACTERS
WITHOUT CLAIM TO ANY PARTICULAR FONT, STYLE,
SIZE, OR COLOR.

OWNER OF U.S. REG. NOS. 3,194,204, 3,990,301 AND
OTHERS.

FOR PAPER PAN LINERS (U.S. CLS. 2, 5, 22, 23, 29, 37,
38 AND 50).

FIRST USE 5-0-2010; IN COMMERCE 5-0-2010.
NANCY CLARKE, EXAMINING ATTORNEY

SN 85-449,854. WILLIAM BURKS SPENCER, SEATTLE, WA.
FILED 10-18-2011.

BREAKING IN

THE MARK CONSISTS OF STANDARD CHARACTERS
WITHOUT CLAIM TO ANY PARTICULAR FONT, STYLE,
SIZE, OR COLOR.

FOR A SERIES OF BOOKS FOCUSING ON BEST
PRACTICES FOR SECURING A JOB IN DIFFERENT
INDUSTRIES (U.S. CLS. 2, 5, 22, 23, 29, 37, 38 AND 50).

JAY FLOWERS, EXAMINING ATTORNEY

SN 85-449,960. VEYS-LEA, RACHELLE, ESCONDIO, CA.
FILED 10-18-2011.

Angelic Expressions

THE MARK CONSISTS OF THE TEXT "ANGELIC EX-
PRESSIONS" IN BROCKSCRIPT FONT.

FOR INTUITIVE DECK OF ARCH ANGEL ORACLE
CARDS (U.S. CLS. 2, 5, 22, 23, 29, 37, 38 AND 50).

FIRST USE 6-26-2011; IN COMMERCE 6-26-2011.
JILL PRATER, EXAMINING ATTORNEY

CLASS 16—(Continued).

SN 85-450,114. DELANEY, ROBERT J., DBA LIL BOBBIES
BOOTY WIPES, SLIDELL, LA. FILED 10-18-2011.

Little Bobbie's Booty Wipes

THE MARK CONSISTS OF STANDARD CHARACTERS
WITHOUT CLAIM TO ANY PARTICULAR FONT, STYLE,
SIZE, OR COLOR.

NO CLAIM IS MADE TO THE EXCLUSIVE RIGHT TO
USE "BOOTY WIPES", APART FROM THE MARK AS
SHOWN.

FOR DISPOSABLE WIPES NOT IMPREGNATED WITH
CHEMICALS OR COMPOUNDS (U.S. CLS. 2, 5, 22, 23, 29,
37, 38 AND 50).

SHAILA SETTLES, EXAMINING ATTORNEY

CLASS 16—(Continued).

SN 85-452,672. TWENTIETH CENTURY FOX FILM COR-
PORATION, LOS ANGELES, CA. FILED 10-20-2011.

CON GARRA

THE MARK CONSISTS OF STANDARD CHARACTERS
WITHOUT CLAIM TO ANY PARTICULAR FONT, STYLE,
SIZE, OR COLOR.

THE ENGLISH TRANSLATION OF "CON GARRA" IN
THE MARK IS "PUNCHY".

FOR STATIONERY; CALENDARS; STICKERS; BOOK-
MARKS; GREETING CARDS; POSTERS; POSTCARDS;
PENS AND PENCILS; TEMPORARY TATTOOS; BLANK
JOURNALS; NOTEBOOKS; ADDRESS BOOKS; DATE
BOOKS; PHOTOGRAPHS; PHOTO ALBUMS; PAPER
FOLDERS; PAPER DOORKNOB HANGERS; TABLE
CLOTHS MADE OF PAPER, PAPER NAPKINS AND
PARTY FAVORS MADE OF PAPER; LUNCH BAGS
MADE OF PAPER; LUNCH BAGS MADE OF TEXTILE;
WRAPPING PAPER; PAPER GIFT BAGS; COMIC
BOOKS; TRADING CARDS; GAME BOOKS, NAMELY,
PARTY GAME BOOKS, GAME BOOKS FEATURING
PAPER GAMES, ACTIVITY GAME BOOKS; SERIES OF
FICTION BOOKS; CARDBOARD STAND-UPS; ART
PRINTS (U.S. CLS. 2, 5, 22, 23, 29, 37, 38 AND 50).

JANICE L. MCMORROW, EXAMINING ATTORNEY

SN 85-457,526. MAGNETNOTES, LTD., TOLEDO, OH. FILED
10-27-2011.

MAGNECOTE

THE MARK CONSISTS OF STANDARD CHARACTERS
WITHOUT CLAIM TO ANY PARTICULAR FONT, STYLE,
SIZE, OR COLOR.

FOR MAGNETIC PAPER (U.S. CLS. 2, 5, 22, 23, 29, 37,
38 AND 50).

FIRST USE 11-1-2008; IN COMMERCE 11-1-2008.

EMILY CHUO, EXAMINING ATTORNEY

SN 85-457,536. MAGNETNOTES, LTD., TOLEDO, OH. FILED
10-27-2011.

BODY SKIN

THE MARK CONSISTS OF STANDARD CHARACTERS
WITHOUT CLAIM TO ANY PARTICULAR FONT, STYLE,
SIZE, OR COLOR.

OWNER OF U.S. REG. NO. 3,150,147.

SEC. 2(F).

FOR TRANSFERS USED TO DECORATE MODEL
RACING CARS (U.S. CLS. 2, 5, 22, 23, 29, 37, 38 AND 50).

FIRST USE 12-1-2003; IN COMMERCE 12-1-2003.

DOUGLAS LEE, EXAMINING ATTORNEY

MAGNECOTE

THE MARK CONSISTS OF THE WORD "MAGNECOTE"
EXCEPT FOR THE "C", WHICH IS PRESENTED AS A
HORSESHOE MAGNET.

FOR MAGNETIC PAPER (U.S. CLS. 2, 5, 22, 23, 29, 37,
38 AND 50).

FIRST USE 11-1-2008; IN COMMERCE 11-1-2008.

EMILY CHUO, EXAMINING ATTORNEY

CLASS 16—(Continued).

SN 85-461,779. VANCE PUBLISHING CORPORATION, LINCOLNSHIRE, IL. FILED 11-1-2011.

CWB

THE MARK CONSISTS OF STANDARD CHARACTERS WITHOUT CLAIM TO ANY PARTICULAR FONT, STYLE, SIZE, OR COLOR.

OWNER OF U.S. REG. NO. 1,729,283.
FOR PRINTED PUBLICATIONS, NAMELY, MAGAZINES IN THE FIELD OF CUSTOM WOOD PRODUCTS MANUFACTURERS (U.S. CLS. 2, 5, 22, 23, 29, 37, 38 AND 50).

FIRST USE 4-30-1991; IN COMMERCE 4-30-1991.
REGINA DRUMMOND, EXAMINING ATTORNEY

SN 85-461,796. VANCE PUBLISHING CORPORATION, LINCOLNSHIRE, IL. FILED 11-1-2011.



OWNER OF U.S. REG. NO. 1,729,283.
NO CLAIM IS MADE TO THE EXCLUSIVE RIGHT TO USE "CUSTOM WOODWORKING BUSINESS", APART FROM THE MARK AS SHOWN.

THE MARK CONSISTS OF THE LETTERS "CWB" IN A LARGE, BOLD FONT WITH THE WORDS "CUSTOM WOODWORKING BUSINESS" IN A SMALLER FONT RUNNING THROUGH IN THE MIDDLE OF THE LETTERS "CWB".

FOR PRINTED PUBLICATIONS, NAMELY, MAGAZINES IN THE FIELD OF CUSTOM WOOD PRODUCTS MANUFACTURERS (U.S. CLS. 2, 5, 22, 23, 29, 37, 38 AND 50).

FIRST USE 4-30-1991; IN COMMERCE 4-30-1991.
REGINA DRUMMOND, EXAMINING ATTORNEY

SN 85-462,914. MERSHO, JOHN, SAN JOSE, CA. FILED 11-2-2011.

theSTNDRD Lifestyle

THE MARK CONSISTS OF STANDARD CHARACTERS WITHOUT CLAIM TO ANY PARTICULAR FONT, STYLE, SIZE, OR COLOR.

NO CLAIM IS MADE TO THE EXCLUSIVE RIGHT TO USE "LIFESTYLE", APART FROM THE MARK AS SHOWN.
FOR MAGAZINES FEATURING ENTERTAINMENT AND LIFESTYLE (U.S. CLS. 2, 5, 22, 23, 29, 37, 38 AND 50).

WILLIAM BRECKENFELD, EXAMINING ATTORNEY

CLASS 16—(Continued).

SN 85-464,722. DIXIE CONSUMER PRODUCTS LLC, ATLANTA, GA. FILED 11-4-2011.

WISE SIZE

THE MARK CONSISTS OF STANDARD CHARACTERS WITHOUT CLAIM TO ANY PARTICULAR FONT, STYLE, SIZE, OR COLOR.

OWNER OF U.S. REG. NOS. 3,450,823 AND 3,823,204.
FOR PAPER NAPKINS (U.S. CLS. 2, 5, 22, 23, 29, 37, 38 AND 50).

NANCY CLARKE, EXAMINING ATTORNEY

SN 85-470,144. THE TOPPS COMPANY, INC., NEW YORK, NY. FILED 11-11-2011.

TIER ONE

THE MARK CONSISTS OF STANDARD CHARACTERS WITHOUT CLAIM TO ANY PARTICULAR FONT, STYLE, SIZE, OR COLOR.

FOR TRADING CARDS (U.S. CLS. 2, 5, 22, 23, 29, 37, 38 AND 50).

FIRST USE 11-9-2011; IN COMMERCE 11-9-2011.
WENDY JUN, EXAMINING ATTORNEY

SN 85-471,421. LOEW-CORNELL, LLC, ERLANGER, KY. FILED 11-14-2011.

Loew-Cornell

THE MARK CONSISTS OF STANDARD CHARACTERS WITHOUT CLAIM TO ANY PARTICULAR FONT, STYLE, SIZE, OR COLOR.

OWNER OF U.S. REG. NOS. 1,354,002, 3,165,968 AND OTHERS.
FOR ARTIST PAINT BRUSHES (U.S. CLS. 2, 5, 22, 23, 29, 37, 38 AND 50).

FIRST USE 12-31-1982; IN COMMERCE 12-31-1982.
JESSICA FATHY, EXAMINING ATTORNEY

CLASS 16—(Continued).

SN 85-474,416. GOOD NEWS PUBLISHERS, WHEATON, IL.
FILED 11-16-2011.



THE MARK CONSISTS OF AN IMAGE OF A MAN SCATTERING SEEDS IN A FIELD. THE MAN IS WEARING A POUCH ON HIS LEFT SIDE, WHICH IS ATTACHED TO HIS BODY BY A SASH THAT GOES DIAGONALLY ACROSS HIS BODY FROM HIS LOWER LEFT SIDE TO HIS RIGHT SHOULDER. THE SEEDS ARE REPRESENTED AS TWO DOTTED LINES GOING FROM THE MAN'S RIGHT HAND IN ARCS TO THE GROUND. THE GROUND IS REPRESENTED BY WAVY LINES AT THE BOTTOM OF THE IMAGE.

FOR PUBLICATIONS, NAMELY, BOOKLETS, BROCHURES, PAMPHLETS, AND TRACTS IN THE FIELDS OF CHRISTIANITY AND RELIGION (U.S. CLS. 2, 5, 22, 23, 29, 37, 38 AND 50).

FIRST USE 0-0-1940; IN COMMERCE 0-0-1940.
MICHAEL TANNER, EXAMINING ATTORNEY

SN 85-486,799. LOEW-CORNELL, LLC, ERLANGER, KY.
FILED 12-5-2011.

Halcyon

THE MARK CONSISTS OF STANDARD CHARACTERS WITHOUT CLAIM TO ANY PARTICULAR FONT, STYLE, SIZE, OR COLOR.

FOR ARTISTS PAINT BRUSHES (U.S. CLS. 2, 5, 22, 23, 29, 37, 38 AND 50).

JESSICA FATHY, EXAMINING ATTORNEY

CLASS 16—(Continued).

SN 85-497,671. ISHA ENTERPRISES, INC., SCOTTSDALE, AZ. FILED 12-16-2011.

EASY GRAMMAR SYSTEMS

THE MARK CONSISTS OF STANDARD CHARACTERS WITHOUT CLAIM TO ANY PARTICULAR FONT, STYLE, SIZE, OR COLOR.

NO CLAIM IS MADE TO THE EXCLUSIVE RIGHT TO USE "GRAMMAR", APART FROM THE MARK AS SHOWN. SEC. 2(F).

FOR EDUCATIONAL GRAMMAR BOOK SERIES (U.S. CLS. 2, 5, 22, 23, 29, 37, 38 AND 50).

FIRST USE 0-0-1996; IN COMMERCE 0-0-1996.
RON FAIRBANKS, EXAMINING ATTORNEY

SN 85-497,722. ISHA ENTERPRISES, INC., SCOTTSDALE, AZ. FILED 12-16-2011.

DAILY GRAMS

THE MARK CONSISTS OF STANDARD CHARACTERS WITHOUT CLAIM TO ANY PARTICULAR FONT, STYLE, SIZE, OR COLOR.

NO CLAIM IS MADE TO THE EXCLUSIVE RIGHT TO USE "DAILY", APART FROM THE MARK AS SHOWN.

FOR EDUCATIONAL BOOK SERIES (U.S. CLS. 2, 5, 22, 23, 29, 37, 38 AND 50).

FIRST USE 5-0-1987; IN COMMERCE 5-0-1987.
RON FAIRBANKS, EXAMINING ATTORNEY

SN 85-511,832. ADVERTISING SPECIALTY INSTITUTE, INC., TREVOSE, PA. FILED 1-9-2012.

PROMOTING SUCCESS

THE MARK CONSISTS OF STANDARD CHARACTERS WITHOUT CLAIM TO ANY PARTICULAR FONT, STYLE, SIZE, OR COLOR.

OWNER OF U.S. REG. NO. 4,090,439.

FOR PUBLICATIONS PUBLISHED PERIODICALLY, NAMELY, MAGAZINES DIRECTED TO THE USE OF PROMOTIONAL PRODUCTS BY BUSINESSES (U.S. CLS. 2, 5, 22, 23, 29, 37, 38 AND 50).

LINDA ESTRADA, EXAMINING ATTORNEY

CLASS 16—(Continued).

SN 85-514,056. IRA GREEN, INC., PROVIDENCE, RI. FILED 1-11-2012.

STORM SAF

THE MARK CONSISTS OF THE WORD "STORM", STYLIZED WITH A CRACKLE EFFECT, ADJACENT TO THE LETTER STRING "SAF", WHICH IS STYLIZED WITH A CRACKLE EFFECT AND HAS A STRAIGHT LINE ABOVE THE LETTER "A".

FOR ALL WEATHER NOTEBOOKS (U.S. CLS. 2, 5, 22, 23, 29, 37, 38 AND 50).

FIRST USE 12-31-1985; IN COMMERCE 12-31-1985.
DANNEAN HETZEL, EXAMINING ATTORNEY

CLASS 16—(Continued).

SN 85-975,031. SK TELECOM CO., LTD., SEOUL, REPUBLIC OF KOREA, FILED 9-21-2010.

3D MAGIC STORY

THE MARK CONSISTS OF STANDARD CHARACTERS WITHOUT CLAIM TO ANY PARTICULAR FONT, STYLE, SIZE, OR COLOR.

NO CLAIM IS MADE TO THE EXCLUSIVE RIGHT TO USE "3D" AND "STORY", APART FROM THE MARK AS SHOWN.

FOR BOOKS IN THE FIELD OF EDUCATION, NAMELY, BOOKS FOR TEACHING SCIENCE, MATHEMATICS, AND SOCIAL STUDIES TO CHILDREN; CHILDREN'S BOOKS FEATURING EDUCATIONAL CONTENT; EDUCATIONAL BOOKS FEATURING EDUCATIONAL CONTENT FOR CHILDREN (U.S. CLS. 2, 5, 22, 23, 29, 37, 38 AND 50).

REGINA DRUMMOND, EXAMINING ATTORNEY

SN 85-517,663. STRATEGIC MARKETING, INC., DUBLIN, OH. FILED 1-17-2012.

Hoy's Toys

THE MARK CONSISTS OF STANDARD CHARACTERS WITHOUT CLAIM TO ANY PARTICULAR FONT, STYLE, SIZE, OR COLOR.

NO CLAIM IS MADE TO THE EXCLUSIVE RIGHT TO USE "TOYS", APART FROM THE MARK AS SHOWN.

FOR ACTIVITY BOOKS (U.S. CLS. 2, 5, 22, 23, 29, 37, 38 AND 50).

FIRST USE 2-0-2009; IN COMMERCE 2-0-2009.
JOHN WILKE, EXAMINING ATTORNEY

CLASS 17—RUBBER GOODS

SN 79-089,651. CONTITECH SCHLAUCH GMBH, FED REP GERMANY, FILED 10-12-2010.

PURPLE SNAKE

THE MARK CONSISTS OF STANDARD CHARACTERS WITHOUT CLAIM TO ANY PARTICULAR FONT, STYLE, SIZE, OR COLOR.

PRIORITY DATE OF 10-12-2010 IS CLAIMED.

OWNER OF INTERNATIONAL REGISTRATION 1057375 DATED 10-12-2010, EXPIRES 10-12-2020.

FOR NON-METALLIC HOSES AND FLEXIBLE PIPES; NON-METAL COUPLINGS FOR USE WITH HOSES FOR USE IN THE BEVERAGE, BREWING AND LIQUOR INDUSTRIES (U.S. CLS. 1, 5, 12, 13, 35 AND 50).

NAKIA HENRY, EXAMINING ATTORNEY

CLASS 17—(Continued).

SN 79-098,959. MORISEI KAKO CO., LTD., JAPAN, FILED 6-2-2011.



PRIORITY DATE OF 5-13-2011 IS CLAIMED.
OWNER OF INTERNATIONAL REGISTRATION 1081506
DATED 6-2-2011, EXPIRES 6-2-2021.

FOR O-RINGS OF RUBBER FOR USE AS CONNECTION SEALS IN INDUSTRIAL APPLICATIONS; O-RINGS OF RUBBER FOR USE AS CONNECTION SEALS FOR VACUUM EQUIPMENT; SEALS OF RUBBER FOR USE AS CONNECTION SEALS FOR VACUUM EQUIPMENT; O-RINGS OF RUBBER FOR USE AS CONNECTION SEALS FOR PRESSURIZED EQUIPMENT; SEALS OF RUBBER FOR USE AS CONNECTION SEALS FOR PRESSURIZED EQUIPMENT; O-RINGS OF RUBBER FOR USE AS CONNECTION SEALS FOR ETCHING EQUIPMENT; SEALS OF RUBBER FOR USE AS CONNECTION SEALS FOR ETCHING EQUIPMENT; O-RINGS OF RUBBER FOR USE WITH PIPES; SEALS OF RUBBER FOR USE IN CONNECTING PIPES; FLEXIBLE RUBBER PIPES; VALVES OF RUBBER FOR PIPES; VALVES OF RUBBER FOR USE AS A CONNECTION FOR ETCHING EQUIPMENT; RUBBER SEALS AND GASKETS; O-RINGS FOR INDUSTRIAL USE; INDUSTRIAL RUBBER COMPONENTS NAMELY MOLDED RUBBER PARTS; O-RINGS OF RUBBER FOR USE IN A GLASS PLATE TRANSPORT DEVICE FOR LCD (LIQUID CRYSTAL DISPLAY) (U.S. CLS. 1, 5, 12, 13, 35 AND 50).

KAREN K. BUSH, EXAMINING ATTORNEY

CLASS 17—(Continued).

SN 85-100,622. HANNO WERK GMBH & CO.KG, DBA HANNO, D 30880 LAATZEN, FED REP GERMANY, FILED 8-5-2010.

Clima-Tect

THE MARK CONSISTS OF STANDARD CHARACTERS WITHOUT CLAIM TO ANY PARTICULAR FONT, STYLE, SIZE, OR COLOR.

PRIORITY CLAIMED UNDER SEC. 44(D) ON FED REP GERMANY APPLICATION NO. 302010007732, FILED 2-28-2010, REG. NO. 302010007732, DATED 4-8-2010, EXPIRES 2-29-2020.

FOR ACOUSTIC AND THERMAL INSULATION FOR USE IN THE AUTOMOTIVE, HVAC, APPLIANCE AND COMMERCIAL INTERIOR INDUSTRIES; ACOUSTICAL INSULATION BARRIER PANELS; ACOUSTICAL INSULATION FOR BUILDINGS; BUILDING INSULATION; CONSTRUCTION MATERIALS, NAMELY, A NONMETAL SUB-FLOOR MEMBRANE FOR RESIDENTIAL AND COMMERCIAL SOUNDPROOFING USE; FOAM INSULATION FOR USE IN BUILDING AND CONSTRUCTION; FOAM SHEETING FOR USE AS A BUILDING INSULATION; INSULATING MATERIALS, NAMELY, POLYURETHANE FOAM AND POLYETHYLENE FOAM; INSULATION IN THE FORM OF FLOOR COVERINGS; PACKING FOAM IN SHEET FORM; PLASTIC SECTIONS FOR USE IN THE MANUFACTURE OF SPACER FRAMES FOR USE AS BUILDING MATERIALS FOR HEAT-INSULATING APPLICATIONS; POLYURETHANE FOAM SHEETING FOR USE AS BUILDING INSULATION; SEALING AND INSULATING MATERIALS; SHEETS OF PLASTIC FABRIC USED AS AN INSULATING INFILTRATION BARRIER IN BUILDING CONSTRUCTION; THERMOPLASTIC AND FOAMED PLASTIC SECTIONS FOR USE IN THE MANUFACTURE OF WINDOWS, DOORS, FACADE GLAZINGS, AND PARTITION WALLS FOR USE AS BUILDING MATERIALS FOR HEAT-INSULATING APPLICATIONS (U.S. CLS. 1, 5, 12, 13, 35 AND 50).

KATHLEEN M. VANSTON, EXAMINING ATTORNEY

SN 85-307,078. GREENOVO RESEARCH, INC., TAIPEI CITY, TAIWAN, FILED 4-28-2011.

ECOBON

THE MARK CONSISTS OF STANDARD CHARACTERS WITHOUT CLAIM TO ANY PARTICULAR FONT, STYLE, SIZE, OR COLOR.

FOR AGRI-BASED POLYURETHANE FOAM FOR USE IN COMPOSITES; BIODEGRADABLE FILM FOR USE IN LINING GARDENS AND FLOWERBEDS; BIODEGRADABLE NON-PAPER PACKAGING AND SHIPPING BUFFERS FOR PHYSICAL AND THERMAL PROTECTION OF ITEMS DURING SHIPPING; PADDING MATERIALS OF RUBBER OR PLASTIC; PLASTIC FILMS USED AS PACKAGING FOR FOOD; EXPANDED PLASTIC PELLETS FOR PACKAGING; PACKAGING MATERIALS MADE FROM STONE-BASED PLASTIC SUBSTITUTES; CARBON FIBERS NOT FOR TEXTILE USE; CHEMICAL FIBER THREAD AND YARN NOT FOR TEXTILE USE; RUBBER DERIVATIVES; FOAM RUBBER; ELECTRIC, THERMAL AND ACOUSTIC INSULATORS; HIGH HEAT THERMOPLASTIC RESIN IN PELLET FORM FOR USE IN MANUFACTURING; NANOCOMPOSITE POLYMER COMPOUNDS IN PELLET FORM FOR USE IN

CLASS 17—(Continued).

FURTHER MANUFACTURE; PLASTIC COMPOSITE MATERIAL IN THE FORM OF PROFILES, BOARDS, SHEETS, BLOCKS, RODS, POWDER, AND PELLETS FOR USE IN MANUFACTURING; PLASTIC FILM FOR COMMERCIAL AND INDUSTRIAL USE; EXTRUDED SEMI-FINISHED GOODS MADE OF SYNTHETIC MATERIALS IN THE FORM OF PLATES, BARS, PIPES AND FLEXIBLE HOSES FOR INDUSTRIAL, CONSTRUCTION AND AGRICULTURAL USE; FOAM FOR USE IN THE MANUFACTURE OF FOOTWEAR; MYCOLOGICAL BIOMATERIAL IN THE NATURE OF A PLASTIC FOAM SUBSTITUTE FOR USE IN THE MANUFACTURE OF BOAT HULLS, THE INSIDE OF WIND TURBINE BLADES, LIGHT WEIGHT VEHICLE PANELS AND THE LIKE; MOISTURE MANAGEMENT CUSHIONING URETHANE FOAMS, FOR USE IN FOOTWEAR AND APPAREL APPLICATIONS; MICA; OPEN CELL FOAM IN ROLL FORM; PLASTIC FOAM USED FOR ARTS AND CRAFTS; PLASTIC IN BARS, BLOCKS, PELLETS, RODS, SHEETS AND TUBES FOR GENERAL INDUSTRIAL USE; PLASTIC IN EXTRUDED FORM FOR GENERAL INDUSTRIAL USE; PLASTIC IN POWDERED FORM; PLASTIC SOLDERING THREADS; POLYPROPYLENE RESINS IN PELLET FORM FOR USE IN FURTHER MANUFACTURE; RESINS IN BARS, BLOCKS, PELLETS, RODS, SHEETS AND TUBES FOR GENERAL INDUSTRIAL USE; RESINS IN EXTRUDED FORM FOR GENERAL INDUSTRIAL USE; SEMI-FINISHED INJECTION MOLDED PRODUCTS OF PLASTIC FOR USE IN A VARIETY OF INDUSTRIES; SEMI-PROCESSED CELLULOSE ACETATE FOR USE IN FURTHER MANUFACTURING; SEMI-PROCESSED PLASTICS; SEMI-WORKED SYNTHETIC PLASTIC AND SYNTHETIC RESINS AS SEMI-FINISHED PRODUCTS IN FORM OF PELLETS, RODS, FOILS, FOAMS, FIBERS, FILMS AND SHEETS; SILICONE RUBBER; SYNTHETIC ELASTOMER RESIN BLENDED WITH ADDITIVES AND COLORANTS SOLD IN A PELLET FORM; SYNTHETIC RUBBER; THERMOPLASTIC COMPOSITE SHEETS CONTAINING GLASS FIBER FOR USE IN THE MANUFACTURE OF OTHER GOODS; THERMOPLASTIC COMPOUNDS, THERMOPLASTIC ELASTOMER RESINS AND THERMOPLASTIC CONCENTRATES IN PELLET FORM FOR USE IN MANUFACTURING IN A WIDE VARIETY OF INDUSTRIES; VISCOUS GEL POLYMER MATERIAL IN SHEET FORM AND CAST SHAPES FOR USE IN THE MANUFACTURE OF CUSTOM CUSHIONED PRODUCTS FOR USE IN THE FIELDS OF MEDICAL, THERAPEUTIC, SAFETY, APPAREL, FOOTWEAR AND SPORTING GOODS (U.S. CLS. 1, 5, 12, 13, 35 AND 50).

FRANK LATTUCA, EXAMINING ATTORNEY

SN 85-307,105. GREENOVO RESEARCH, INC., TAIPEI CITY, TAIWAN, FILED 4-28-2011.

ECOBELLA

THE MARK CONSISTS OF STANDARD CHARACTERS WITHOUT CLAIM TO ANY PARTICULAR FONT, STYLE, SIZE, OR COLOR.

FOR AGRI-BASED POLYURETHANE FOAM FOR USE IN COMPOSITES; BIODEGRADABLE FILM FOR USE IN LINING GARDENS AND FLOWERBEDS; BIODEGRADABLE NON-PAPER PACKAGING AND SHIPPING BUFFERS FOR PHYSICAL AND THERMAL PROTECTION OF ITEMS DURING SHIPPING; PADDING MATERIALS OF RUBBER OR PLASTIC; PLASTIC FILMS USED AS PACKAGING FOR FOOD; EXPANDED PLASTIC PELLETS FOR PACKAGING; PACKAGING MATERIALS MADE FROM STONE-BASED PLASTIC SUBSTITUTES; CARBON FIBERS NOT FOR TEXTILE USE; CHEMICAL FIBER THREAD AND YARN NOT FOR TEXTILE USE; RUBBER DERIVATIVES; FOAM RUBBER; ELECTRIC, THERMAL AND ACOUSTIC INSULATORS; HIGH HEAT THERMOPLASTIC RESIN IN PELLET FORM FOR USE

CLASS 17—(Continued).

IN MANUFACTURING; NANOCOMPOSITE POLYMER COMPOUNDS IN PELLET FORM FOR USE IN FURTHER MANUFACTURE; PLASTIC COMPOSITE MATERIAL IN THE FORM OF PROFILES, BOARDS, SHEETS, BLOCKS, RODS, POWDER, AND PELLETS FOR USE IN MANUFACTURING; PLASTIC FILM FOR COMMERCIAL AND INDUSTRIAL USE; EXTRUDED SEMI-FINISHED GOODS MADE OF SYNTHETIC MATERIALS IN THE FORM OF PLATES, BARS, PIPES AND FLEXIBLE HOSES FOR INDUSTRIAL, CONSTRUCTION AND AGRICULTURAL USE; FOAM FOR USE IN THE MANUFACTURE OF FOOTWEAR; MYCOLOGICAL BIOMATERIAL IN THE NATURE OF A PLASTIC FOAM SUBSTITUTE FOR USE IN THE MANUFACTURE OF BOAT HULLS, THE INSIDE OF WIND TURBINE BLADES, LIGHT WEIGHT VEHICLE PANELS AND THE LIKE; MOISTURE MANAGEMENT CUSHIONING URETHANE FOAMS, FOR USE IN FOOTWEAR AND APPAREL APPLICATIONS; MICA; OPEN CELL FOAM IN ROLL FORM; PLASTIC FOAM USED FOR ARTS AND CRAFTS; PLASTIC IN BARS, BLOCKS, PELLETS, RODS, SHEETS AND TUBES FOR GENERAL INDUSTRIAL USE; PLASTIC IN EXTRUDED FORM FOR GENERAL INDUSTRIAL USE; PLASTIC IN POWDERED FORM; PLASTIC SOLDERING THREADS; POLYPROPYLENE RESINS IN PELLET FORM FOR USE IN FURTHER MANUFACTURE; RESINS IN BARS, BLOCKS, PELLETS, RODS, SHEETS AND TUBES FOR GENERAL INDUSTRIAL USE; RESINS IN EXTRUDED FORM FOR GENERAL INDUSTRIAL USE; SEMI-FINISHED INJECTION MOLDED PRODUCTS OF PLASTIC FOR USE IN A VARIETY OF INDUSTRIES; SEMI-PROCESSED CELLULOSE ACETATE FOR USE IN FURTHER MANUFACTURING; SEMI-PROCESSED PLASTICS; SEMI-WORKED SYNTHETIC PLASTIC AND SYNTHETIC RESINS AS SEMI-FINISHED PRODUCTS IN FORM OF PELLETS, RODS, FOILS, FOAMS, FIBERS, FILMS AND SHEETS; SILICONE RUBBER; SYNTHETIC ELASTOMER RESIN BLENDED WITH ADDITIVES AND COLORANTS SOLD IN A PELLET FORM; SYNTHETIC RUBBER; THERMOPLASTIC COMPOSITE SHEETS CONTAINING GLASS FIBER FOR USE IN THE MANUFACTURE OF OTHER GOODS; THERMOPLASTIC COMPOUNDS, THERMOPLASTIC ELASTOMER RESINS AND THERMOPLASTIC CONCENTRATES IN PELLET FORM FOR USE IN MANUFACTURING IN A WIDE VARIETY OF INDUSTRIES; VISCOUS GEL POLYMER MATERIAL IN SHEET FORM AND CAST SHAPES FOR USE IN THE MANUFACTURE OF CUSTOM CUSHIONED PRODUCTS FOR USE IN THE FIELDS OF MEDICAL, THERAPEUTIC, SAFETY, APPAREL, FOOTWEAR AND SPORTING GOODS (U.S. CLS. 1, 5, 12, 13, 35 AND 50).

FRANK LATTUCA, EXAMINING ATTORNEY

SN 85-436,385. TAMA PLASTIC INDUSTRY, MISHMAR HA'EMEK, ISRAEL, FILED 9-30-2011.

Z-LOCK

THE MARK CONSISTS OF STANDARD CHARACTERS WITHOUT CLAIM TO ANY PARTICULAR FONT, STYLE, SIZE, OR COLOR.

FOR PLASTIC FILM FOR COMMERCIAL USE AND PLASTIC SHEETING FOR WRAPPING BALES OF COTTON FOR INDUSTRIAL AND COMMERCIAL USE; PLASTIC MATERIALS IN SHEET FORM FOR WRAPPING AGRICULTURAL CROPS (U.S. CLS. 1, 5, 12, 13, 35 AND 50).

FIRST USE 6-27-2007; IN COMMERCE 6-27-2007.

KATINA MISTER, EXAMINING ATTORNEY

CLASS 17—(Continued).

SN 85-447,413. POLYSTRAND, INC., MONTROSE, CO.
FILED 10-14-2011.

TECHSTRAND

THE MARK CONSISTS OF STANDARD CHARACTERS WITHOUT CLAIM TO ANY PARTICULAR FONT, STYLE, SIZE, OR COLOR.

FOR PLASTIC IMPREGNATED COMPOSITE MATERIAL IN THE FORM OF REINFORCEMENT FIBERS IMPREGNATED WITH THERMOSET OR THERMOPLASTIC FOR USE IN MANUFACTURING FIBER-REINFORCED COMPOSITE STRUCTURES (U.S. CLS. 1, 5, 12, 13, 35 AND 50).

BERNICE MIDDLETON, EXAMINING ATTORNEY

CLASS 17—(Continued).

SN 85-449,831. RBP CHEMICAL TECHNOLOGY, INC., MILWAUKEE, WI. FILED 10-18-2011.

SIMPLESPlice

THE MARK CONSISTS OF STANDARD CHARACTERS WITHOUT CLAIM TO ANY PARTICULAR FONT, STYLE, SIZE, OR COLOR.

FOR ADHESIVE TAPE FOR INDUSTRIAL OR COMMERCIAL USE FOR USE IN THE PRINTING INDUSTRY (U.S. CLS. 1, 5, 12, 13, 35 AND 50).

SETH A. RAPPAPORT, EXAMINING ATTORNEY

SN 85-447,431. SWEZEY, RICHARD, SANTA MONICA, CA.
FILED 10-14-2011.

CLOUD-FOAM

THE MARK CONSISTS OF STANDARD CHARACTERS WITHOUT CLAIM TO ANY PARTICULAR FONT, STYLE, SIZE, OR COLOR.

FOR STUFFING COMPOSED OF POLYETHYLENE, RUBBER, OR PLASTIC FOR USE IN THE MANUFACTURE OF PILLOWS, CUSHIONS, COMFORTERS, DUVETS AND UPHOLSTERED FURNITURE (U.S. CLS. 1, 5, 12, 13, 35 AND 50).

FIRST USE 2-10-2011; IN COMMERCE 8-23-2011.
LESLEY LAMOTHE, EXAMINING ATTORNEY

SN 85-450,070. FOAM SEAL, INC., CLEVELAND, OH. FILED 10-18-2011.

NOVAGARD UV

THE MARK CONSISTS OF STANDARD CHARACTERS WITHOUT CLAIM TO ANY PARTICULAR FONT, STYLE, SIZE, OR COLOR.

OWNER OF U.S. REG. NOS. 2,136,919, 3,846,309 AND OTHERS.

NO CLAIM IS MADE TO THE EXCLUSIVE RIGHT TO USE "UV", APART FROM THE MARK AS SHOWN.

FOR SILICONE BASED SEALANTS AND ADHESIVES (U.S. CLS. 1, 5, 12, 13, 35 AND 50).

KAREN K. BUSH, EXAMINING ATTORNEY

SN 85-447,521. JEFFREY M. TANNER, DBA FLOW-LINER SYSTEMS, LTD., ZANESVILLE, OH. FILED 10-14-2011.

CIP Conduit

THE MARK CONSISTS OF STANDARD CHARACTERS WITHOUT CLAIM TO ANY PARTICULAR FONT, STYLE, SIZE, OR COLOR.

NO CLAIM IS MADE TO THE EXCLUSIVE RIGHT TO USE "CONDUIT", APART FROM THE MARK AS SHOWN.

FOR INTERIOR LININGS MADE OF NON-METAL FABRIC AND SEALANT FOR THE REPAIR OF ELECTRICAL, TELECOMMUNICATION AND NATURAL GAS UTILITY CONDUITS AND PIPES (U.S. CLS. 1, 5, 12, 13, 35 AND 50).

FIRST USE 8-1-2009; IN COMMERCE 7-15-2011.
HOWARD SMIGA, EXAMINING ATTORNEY

SN 85-450,411. CTA ACOUSTICS, INC., CORBIN, KY. FILED 10-18-2011.

THERMABLEND

THE MARK CONSISTS OF STANDARD CHARACTERS WITHOUT CLAIM TO ANY PARTICULAR FONT, STYLE, SIZE, OR COLOR.

FOR ACOUSTICAL AND THERMAL INSULATION FOR APPLIANCES, COMMERCIAL, CONSTRUCTION, HEATING, AIR CONDITIONING, AUTOMOTIVE, AND INDUSTRIAL APPLICATIONS (U.S. CLS. 1, 5, 12, 13, 35 AND 50).

NAPOLEON SHARMA, EXAMINING ATTORNEY

CLASS 18—LEATHER GOODS

SN 77-467,206. DECKERS OUTDOOR CORPORATION, GOLETA, CA. FILED 5-6-2008.

CLASS 18—(Continued).

SN 85-240,195. ROOTS CANADA LTD., TORONTO, ONTARIO, CANADA, FILED 2-11-2011.

FREAKS OF NATURE

THE MARK CONSISTS OF STANDARD CHARACTERS WITHOUT CLAIM TO ANY PARTICULAR FONT, STYLE, SIZE, OR COLOR.

FOR BAGS, NAMELY, ATHLETIC BAGS; AND PACKS, NAMELY, BACKPACKS, DAYPACKS AND SPORTS PACKS (U.S. CLS. 1, 2, 3, 22 AND 41).
CHRISTINE COOPER, EXAMINING ATTORNEY



SN 79-099,134. FURLA S.P.A., ITALY, FILED 2-22-2011.



PRIORITY DATE OF 2-11-2011 IS CLAIMED.
OWNER OF INTERNATIONAL REGISTRATION 1082031 DATED 2-22-2011, EXPIRES 2-22-2021.

NO CLAIM IS MADE TO THE EXCLUSIVE RIGHT TO USE "BAG", APART FROM THE MARK AS SHOWN.

THE MARK CONSISTS OF AN INCOMPLETE RECTANGLE BORDERED BY TWO LINES CONTAINING THE STYLIZED WORDING "FURLA" AT THE TOP AND IN THE MIDDLE AND THE STYLIZED WORDING "CANDY BAG" WITHIN THE RECTANGLE.

FOR BAGS IN THE NATURE OF SATCHELS, HANDBAGS, CLUTCH BAGS, TRAVELLING BAGS OF LEATHER, MESH SHOPPING BAGS NOT OF PRECIOUS METALS, SHOULDER BAGS, POUCHES OF TEXTILE AND LEATHER, RUCKSACKS, HOLDALLS, REUSABLE SHOPPING BAGS; EMPTY DIARY CASES IN THE NATURE OF BRIEFCASE-TYPE PORTFOLIOS AND DOCUMENT CASES; VINTAGE BAGS IN THE NATURE OF HANDBAGS AND HAVERSACKS; WALLETS, PURSES, BRIEFCASES FOR DOCUMENTS; CARRYING CASES FOR DOCUMENTS; VISITING CARD CASES IN THE NATURE BUSINESS CARD CASES, LUGGAGE, SUITCASES, SUIT CARRIERS FOR TRAVELLING, ATTACHE CASES, TRUNKS; SMALL CASES DESIGNED TO CONTAIN TOILETRY ARTICLES, NAMELY, VANITY CASES SOLD EMPTY; VANITY CASES, NOT FITTED; KEY CASES OF LEATHER; KEY WALLETS; KEY BAGS; CASES FOR HOLDING KEYS; CASES OF LEATHER OR IMITATION LEATHER FOR MANICURE AND PEDICURE HAND SETS, SOLD EMPTY; UMBRELLAS, PARASOLS AND WALKING STICKS, SADDLERY (U.S. CLS. 1, 2, 3, 22 AND 41).
KRISTINA MORRIS, EXAMINING ATTORNEY

OWNER OF U.S. REG. NOS. 1,815,610, 2,141,642 AND OTHERS.

NO CLAIM IS MADE TO THE EXCLUSIVE RIGHT TO USE "MADE IN CANADA" AND "GENUINE LEATHER", APART FROM THE MARK AS SHOWN.

THE MARK CONSISTS OF THE WORD "ROOTS" APPEARING IN THE CENTER OF A CIRCLE. ABOVE THE WORD, THE TERM "MADE IN" APPEARS INSIDE A SEMI-CIRCLE, AND, BELOW, THE TERM "CANADA" APPEARS INSIDE A SEMI-CIRCLE. THE WORD "GENUINE" APPEARS IN THE TOP HALF OF THE CIRCLE, AND THE WORD "LEATHER" APPEARS IN THE BOTTOM HALF.

FOR LUGGAGE, HANDBAGS, KEY CASES, LEATHER KEY CHAINS, CLUTCHES, NAMELY, CLUTCH BAGS, CHANGE PURSES, BUSINESS CARD HOLDERS IN THE NATURE OF CARD CASES, LUGGAGE TAGS, HIP BAGS, BACKPACKS, BRIEFCASES, TOTE BAGS, GYM BAGS, BAGS FOR SPORT, YOGA BAGS, CARRY ON BAGS; BAGS FOR SHAVING KITS, SOLD EMPTY; BRIEF-CASE TYPE PORTFOLIOS; COSMETIC BAGS, SOLD EMPTY; SCHOOL SATCHELS, LEATHER CREDIT CARD CASES, TRAVELLING TRUNKS, RUCKSACKS, PURSES NOT MADE OF PRECIOUS METAL, POCKET WALLETS, LEATHER SHOPPING BAGS, ATTACHE CASES, BAGS FOR CLIMBERS AND BAGS FOR CAMPERS IN THE NATURE OF ALL-PURPOSE CARRYING BAGS, BEACH BAGS, HANDBAGS, TRAVELLING BAGS, VALISES, CHAIN MESH PURSES NOT MADE OF PRECIOUS METAL, TRUNKS, NAMELY, LUGGAGE, UNFITTED VANITY CASES, GARMENT BAGS FOR TRAVEL, HAVERSACKS, LEATHER KEY CASES, SUITCASES, ALL OF THE AFORESAID CONTAINING GENUINE LEATHER (U.S. CLS. 1, 2, 3, 22 AND 41).
GISELLE AGOSTO, EXAMINING ATTORNEY

CLASS 18—(Continued).

SN 85-274,360. MASCOTTE HOLDINGS, INC., NEW YORK, NY. FILED 3-23-2011.

YEEZI

THE MARK CONSISTS OF STANDARD CHARACTERS WITHOUT CLAIM TO ANY PARTICULAR FONT, STYLE, SIZE, OR COLOR.

THE NAME SHOWN IN THE MARK IDENTIFIES KANYE WEST A LIVING INDIVIDUAL, WHOSE CONSENT TO REGISTER IS MADE OF RECORD.

FOR ALL-PURPOSE SPORTS AND ATHLETIC BAGS; BEACH, BOOK, CARRY-ON, DUFFEL, DIAPER, GYM, LEATHER SHOPPING, SHOULDER, TOTE AND TRAVEL BAGS; FANNY PACKS AND WAIST PACKS; BACK-PACKS; KNAPSACKS; PURSES; GARMENT BAGS FOR TRAVEL; SATCHELS; LUGGAGE; LUGGAGE TAGS; TRUNKS; SUITCASES; HAT BOXES FOR TRAVEL NOT OF PAPER OR CARDBOARD; COSMETIC CASES AND BAGS SOLD EMPTY; TOILETRY AND VANITY CASES SOLD EMPTY; TOOL BAGS SOLD EMPTY; ATTACHE CASES; BRIEFCASES; BRIEFCASE-TYPE PORTFOLIOS; DOCUMENT CASES; MEN'S CLUTCHES; BUSINESS CASES; BUSINESS CARD CASES; CALLING AND CREDIT CARD CASES; KEY CASES; LEATHER KEY CHAINS; WALLETS; BANKNOTE HOLDERS; BILL-FOLDS; UMBRELLAS; PARASOLS; WALKING STICKS (U.S. CLS. 1, 2, 3, 22 AND 41).

CHARISMA HAMPTON, EXAMINING ATTORNEY

SN 85-288,280. AWA DESIGNS, INC., VALLEY STREAM, NY. FILED 4-6-2011.

ARDEN ELLIS

THE MARK CONSISTS OF STANDARD CHARACTERS WITHOUT CLAIM TO ANY PARTICULAR FONT, STYLE, SIZE, OR COLOR.

OWNER OF U.S. REG. NO. 3,958,709.

THE NAME(S), PORTRAIT(S), AND/OR SIGNATURE(S) SHOWN IN THE MARK IDENTIFIES ARDEN WAX, WHOSE CONSENT(S) TO REGISTER IS MADE OF RECORD.

FOR BACKPACKS; COSMETIC BAGS SOLD EMPTY; FASHION HANDBAGS; HANDBAGS; LUGGAGE; SPORTS BAGS; TOTE BAGS; TRAVEL BAGS; WALLETS (U.S. CLS. 1, 2, 3, 22 AND 41).

FIRST USE 1-0-2011; IN COMMERCE 1-0-2011.

ALLISON HOLTZ, EXAMINING ATTORNEY

CLASS 18—(Continued).

SN 85-301,645. LEHMAN BROTHERS HOLDINGS INC., NEW YORK, NY. FILED 4-21-2011.

SETAI

THE MARK CONSISTS OF STANDARD CHARACTERS WITHOUT CLAIM TO ANY PARTICULAR FONT, STYLE, SIZE, OR COLOR.

FOR LEATHER AND IMITATIONS OF LEATHER; LEATHER AND IMITATION LEATHER GOODS, NAMELY, BILLFOLDS, WALLETS, KEYCHAINS, PURSES AND BRIEFCASES; ANIMAL SKINS AND HIDES; TRUNKS AND TRAVELLING BAGS; UMBRELLAS, PARASOLS AND WALKING STICKS; HARNESSES AND SADDLERY; HANDBAGS; LUGGAGE (U.S. CLS. 1, 2, 3, 22 AND 41).

KATHERINE CHANG, EXAMINING ATTORNEY

SN 85-306,479. SAN ANTONIO LIVESTOCK EXPOSITION, INC., SAN ANTONIO, TX. FILED 4-27-2011.



THE MARK CONSISTS OF THE LETTER "S" DESIGNED TO FORM A COWBOY HAT.

FOR LEATHER GOODS, NAMELY, BRIEF CASES, HANDBAGS, SADDLES, HORSE TACK, NAMELY, BRIDLES, REINS, HALTERS (U.S. CLS. 1, 2, 3, 22 AND 41).

FIRST USE 2-28-2003; IN COMMERCE 2-28-2003.

THEODORE MCBRIDE, EXAMINING ATTORNEY

SN 85-324,324. HORIZON GROUP USA, INC., WARREN, NJ. FILED 5-18-2011.

SCHOOL FX

THE MARK CONSISTS OF STANDARD CHARACTERS WITHOUT CLAIM TO ANY PARTICULAR FONT, STYLE, SIZE, OR COLOR.

NO CLAIM IS MADE TO THE EXCLUSIVE RIGHT TO USE "SCHOOL", APART FROM THE MARK AS SHOWN.

FOR BACKPACKS; LUGGAGE; POUCHES FOR HOLDING KEYS; LEATHER KEY CHAINS (U.S. CLS. 1, 2, 3, 22 AND 41).

REGINA DRUMMOND, EXAMINING ATTORNEY

CLASS 18—(Continued).

SN 85-350,635. NEO-PAWS INTERNATIONAL INC, TORONTO, CANADA, FILED 6-20-2011.

THE BEST DOG SHOES, PAWS
DOWN!

THE MARK CONSISTS OF STANDARD CHARACTERS WITHOUT CLAIM TO ANY PARTICULAR FONT, STYLE, SIZE, OR COLOR.

NO CLAIM IS MADE TO THE EXCLUSIVE RIGHT TO USE "DOG SHOES", APART FROM THE MARK AS SHOWN.

FOR DOG SHOES (U.S. CLS. 1, 2, 3, 22 AND 41).
KELLEY WELLS, EXAMINING ATTORNEY

SN 85-357,372. BROWN, CHRISTINE, BROOKLYN, NY. FILED 6-27-2011.

glitter critter

THE MARK CONSISTS OF STANDARD CHARACTERS WITHOUT CLAIM TO ANY PARTICULAR FONT, STYLE, SIZE, OR COLOR.

NO CLAIM IS MADE TO THE EXCLUSIVE RIGHT TO USE "GLITTER", APART FROM THE MARK AS SHOWN.

FOR COLLARS FOR PETS; PET CLOTHING (U.S. CLS. 1, 2, 3, 22 AND 41).
JORDAN BAKER, EXAMINING ATTORNEY

SN 85-371,141. NEO-PAWS INTERNATIONAL INC, DBA NEO-PAWS INTERNATIONAL INC, TORONTO, CANADA, FILED 7-14-2011.

LEADER IN BOOTIFUL SAFETY
PET APPAREL

THE MARK CONSISTS OF STANDARD CHARACTERS WITHOUT CLAIM TO ANY PARTICULAR FONT, STYLE, SIZE, OR COLOR.

OWNER OF U.S. REG. NO. 8,537,114.
NO CLAIM IS MADE TO THE EXCLUSIVE RIGHT TO USE "SAFETY PET APPAREL", APART FROM THE MARK AS SHOWN.

FOR DOG APPAREL; DOG CLOTHING (U.S. CLS. 1, 2, 3, 22 AND 41).
FIRST USE 9-1-1992; IN COMMERCE 9-1-1992.
KELLEY WELLS, EXAMINING ATTORNEY

CLASS 18—(Continued).

SN 85-380,142. POMBOS INC., DORAL, FL. FILED 7-25-2011.

THE MARK CONSISTS OF SIX LETTERS FORMING THE WORD "P O M B O S", WITH THE LETTER "M" IN A BOLD FONT TYPE, 1.5X BIGGER THAN THE REST OF THE LETTERS, WITH A MODIFIED TWO SUPERIORS ANGLES, AND WITH TWO ELEMENTS LOCATED OVER THE LETTER "M", IN A LEFT POSITION. THE FIRST ELEMENT IS A SEMI-CURVE WHERE THE CONCAVE SIDE FACES THE LETTER "M". THE SECOND ELEMENT IS A CLASSIC CIRCLE COMPLETELY FILLED, LOCATED OVER THE FIRST ELEMENT CENTERED.

THE ENGLISH TRANSLATION OF "POMBOS" IN THE MARK IS "PIGEON".

FOR ALL PURPOSE SPORT BAGS; ALL-PURPOSE ATHLETIC BAGS; ALL-PURPOSE CARRYING BAGS; BACKPACKS, BOOK BAGS, SPORTS BAGS, BUM BAGS, WALLETS AND HANDBAGS; COSMETIC BAGS SOLD EMPTY; DUFFEL BAGS; SPORT BAGS; TOILETRY BAGS SOLD EMPTY; TRAVEL BAGS (U.S. CLS. 1, 2, 3, 22 AND 41).

FIRST USE 5-8-2009; IN COMMERCE 12-28-2010.
ERIN FALK, EXAMINING ATTORNEY

SN 85-411,768. NORDSTROM, INC., SEATTLE, WA. FILED 8-31-2011.

CLASSIQUES ENTIER ATELIER

THE MARK CONSISTS OF STANDARD CHARACTERS WITHOUT CLAIM TO ANY PARTICULAR FONT, STYLE, SIZE, OR COLOR.

OWNER OF U.S. REG. NO. 2,065,348.
NO CLAIM IS MADE TO THE EXCLUSIVE RIGHT TO USE "CLASSIQUES" AND "ATELIER", APART FROM THE MARK AS SHOWN.

THE ENGLISH TRANSLATION OF "CLASSIQUES ENTIER" IN THE MARK IS "ENTIRELY CLASSICAL", AND THE ENGLISH TRANSLATION OF "ATELIER" IS "STUDIO" OR "WORKSHOP".

FOR HANDBAGS, WALLETS, TRAVEL BAGS AND KEY CASES (U.S. CLS. 1, 2, 3, 22 AND 41).
LINDA ORNDORFF, EXAMINING ATTORNEY

CLASS 18—(Continued).

SN 85-434,184. HYDER, SANAA Z., SCARSDALE, NY. FILED 9-28-2011.

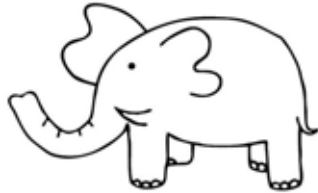

THE MARK CONSISTS OF A DRAWING OF AN ELEPHANT.

FOR HANDBAGS, TRAVEL BAGS, SHOULDER BAGS, LUGGAGE, AND CLUTCHES (U.S. CLS. 1, 2, 3, 22 AND 41).

DOMINIC J. FERRAIUOLO, EXAMINING ATTORNEY

SN 85-444,640. HERMES INTERNATIONAL, 75008 PARIS, FRANCE, FILED 10-11-2011.

CABALICOL

THE MARK CONSISTS OF STANDARD CHARACTERS WITHOUT CLAIM TO ANY PARTICULAR FONT, STYLE, SIZE, OR COLOR.

PRIORITY CLAIMED UNDER SEC. 44(D) ON FRANCE APPLICATION NO. 113823755, FILED 4-14-2011, REG. NO. 113823755, DATED 4-14-2011, EXPIRES 4-14-2021.

THE WORDING "CABALICOL" HAS NO MEANING IN A FOREIGN LANGUAGE.

FOR GOODS MADE OF LEATHER AND IMITATIONS OF LEATHER, NAMELY, HANDBAGS, TRAVELLING BAGS, RUCKSACKS, SCHOOL SATCHELS AND SCHOOL BAGS, BEACH BAGS, SHOPPING BAGS MADE OF CANVAS, LEATHER AND TEXTILE, GARMENT BAGS FOR TRAVEL, BAGS FOR SPORT, WHEELED SHOPPING BAGS, LEATHER SACKS AND POUCHES FOR PACKAGING, POCKET WALLETS, PURSES, BUSINESS CARD CASES, CREDIT CARD CASES, ATTACHE-CASES, BRIEFCASES, KEY CASES IN LEATHER, TRUNKS AND SUITCASES, TOILETRY BAGS SOLD EMPTY, VANITY CASES SOLD EMPTY, HANDBAGS FOR EVENING (U.S. CLS. 1, 2, 3, 22 AND 41).

BRIAN CALLAGHAN, EXAMINING ATTORNEY

CLASS 18—(Continued).

SN 85-445,361. NO. 9 CHRISTOPHER LLC, NEW YORK, NY. FILED 10-12-2011.

NO 9 CHRISTOPHER

THE MARK CONSISTS OF STANDARD CHARACTERS WITHOUT CLAIM TO ANY PARTICULAR FONT, STYLE, SIZE, OR COLOR.

FOR LEATHER GOODS, NAMELY, BRIEFCASES; CASUAL SPORT BAGS; ALL-PURPOSE ATHLETIC BAGS; SPORTS BAGS; LUGGAGE; BACKPACKS; DUFFLE BAGS; FANNY PACKS; BOOK BAGS; MESSENGER BAGS; PURSES; WALLETS; KEY CASES; UMBRELLAS; LEATHER KEY CHAINS; BRIEFCASE-TYPE PORTFOLIOS; COSMETIC CASES SOLD EMPTY; UMBRELLAS; LUGGAGE TAGS; HAND BAGS; TOTE BAGS (U.S. CLS. 1, 2, 3, 22 AND 41).

SALLY SHIH, EXAMINING ATTORNEY

SN 85-447,777. SCOTT, ALISON MARIE, NEW ORLEANS, LA. FILED 10-14-2011.

DOGANANDA

THE MARK CONSISTS OF STANDARD CHARACTERS WITHOUT CLAIM TO ANY PARTICULAR FONT, STYLE, SIZE, OR COLOR.

FOR PET CLOTHING (U.S. CLS. 1, 2, 3, 22 AND 41).

KEVIN CORWIN, EXAMINING ATTORNEY

SN 85-448,317. PRIX-PRIX LLC, DBA JETSAM, SAN DIEGO, CA. FILED 10-15-2011.

JETSAM

THE MARK CONSISTS OF STANDARD CHARACTERS WITHOUT CLAIM TO ANY PARTICULAR FONT, STYLE, SIZE, OR COLOR.

FOR WALLETS (U.S. CLS. 1, 2, 3, 22 AND 41). FIRST USE 4-18-2011; IN COMMERCE 4-18-2011.

ANDREW RHIM, EXAMINING ATTORNEY

CLASS 18—(Continued).

SN 85-448,807. B'S KNEES, LLC, MINNEAPOLIS, MN. FILED 10-17-2011.

ISABRELLA

THE MARK CONSISTS OF STANDARD CHARACTERS WITHOUT CLAIM TO ANY PARTICULAR FONT, STYLE, SIZE, OR COLOR.

FOR ANCHOR SPECIALLY ADAPTED FOR A BEACH UMBRELLA (U.S. CLS. 1, 2, 3, 22 AND 41).
FIRST USE 6-6-2011; IN COMMERCE 6-6-2011.
CARYN GLASSER, EXAMINING ATTORNEY

CLASS 18—(Continued).

SN 85-449,684. STUDIO IMPORTS LTD., INC., HOLLYWOOD, ID. FILED 10-18-2011.



OWNER OF U.S. REG. NO. 1,723,781.
THE MARK CONSISTS OF THE WORD "BRACIANO" IN STYLIZED LETTERS WITH A PINEAPPLE SUSPENDED OVER THE MIDDLE OF THE WORD.

THE WORDING "BRACIANO" HAS NO MEANING IN A FOREIGN LANGUAGE.

FOR HANDBAGS, TOTE BAGS, CARRYALL BAGS, CLUTCH BAGS, DUFFEL BAGS, PURSES, WALLETS, COIN PURSES, AND POUCHES FOR HOLDING MAKE-UP, KEYS, OR OTHER PERSONAL ITEMS (U.S. CLS. 1, 2, 3, 22 AND 41).

FIRST USE 1-5-2011; IN COMMERCE 1-5-2011.
KIMBERLY FRYE, EXAMINING ATTORNEY

SN 85-449,164. BRAVO ENTERPRISE, BATON ROUGE, LA. FILED 10-17-2011.

TackleTime

THE MARK CONSISTS OF STANDARD CHARACTERS WITHOUT CLAIM TO ANY PARTICULAR FONT, STYLE, SIZE, OR COLOR.

FOR BACKPACKS, BOOK BAGS, SPORTS BAGS, BUM BAGS, WALLETS AND HANDBAGS (U.S. CLS. 1, 2, 3, 22 AND 41).

FIRST USE 6-1-2011; IN COMMERCE 9-1-2011.
DOMINIC FATHY, EXAMINING ATTORNEY

SN 85-449,867. HOLLYWOOD WORLD GROUP INC., LOS ANGELES, CA. FILED 10-18-2011.

THE ORIGINAL SUITCASE JERSEY

SN 85-449,644. CONTINENTAL SADDLERY INC., DBA CONTINENTAL SADDLERY, IDER, AL. FILED 10-18-2011.



THE MARK CONSISTS OF A WINGED HORSE/PEGASUS WITH CLAWS ON ITS FEET HOLDING A CIRCLE IN ITS CLAWS. EMBEDDED WITHIN THE CIRCLE IS A LARGE HORSESHOE SIDEWAYS TO APPEAR AS THE LETTER "C". WITHIN THE LARGE HORSESHOE ARE TWO SMALLER HORSESHOES CONNECTED TO FORM THE LETTER "S". OUTSIDE OF THE CIRCLE AND UNDERNEATH ARE THE WORDS "REINING AUTHORITY" FOLLOWING ALONG THE OUTSIDE OF THE CIRCLE.

FOR RIDING SADDLES; SADDLE COVERS; SADDLES (U.S. CLS. 1, 2, 3, 22 AND 41).
FIRST USE 4-1-2011; IN COMMERCE 4-1-2011.
ALAIN LAPTER, EXAMINING ATTORNEY

THE MARK CONSISTS OF STANDARD CHARACTERS WITHOUT CLAIM TO ANY PARTICULAR FONT, STYLE, SIZE, OR COLOR.

FOR FITTED PROTECTIVE COVERS FOR HANDBAGS, BRIEFCASES, VALISES, SUITCASES, AND BRIEFCASE-LIKE PORTFOLIOS (U.S. CLS. 1, 2, 3, 22 AND 41).

KELLEY WELLS, EXAMINING ATTORNEY

CLASS 18—(Continued).

SN 85-450,051. TULA INC., LA MESA, CA. FILED 10-18-2011.



THE COLOR(S) BROWN AND WHITE IS/ARE CLAIMED AS A FEATURE OF THE MARK.

THE MARK CONSISTS OF A FACE WITH THE EYES CLOSED, MOUTH CLOSED BUT SMILING. THE EARS ARE STICKING OUT FROM THE SIDE OF THE HEAD. THE WORD "TULA" IS CENTERED AND DIRECTLY BELOW THE SLEEPING FACE. THE WORDING OF "TULA" IS IN BROWN AS WELL AS THE OUTLINE OF THE SLEEPING FACE AND EYES, NOSE AND MOUTH AND THE BACKGROUND OF THE WORDS AND SLEEPING FACE IS WHITE.

FOR BABY CARRIERS WORN ON THE BODY; INFANT CARRIERS WORN ON THE BODY (U.S. CLS. 1, 2, 3, 22 AND 41).

NAAKWAMA ANKRAH, EXAMINING ATTORNEY

SN 85-452,676. TWENTIETH CENTURY FOX FILM CORPORATION, LOS ANGELES, CA. FILED 10-20-2011.

CON GARRA

THE MARK CONSISTS OF STANDARD CHARACTERS WITHOUT CLAIM TO ANY PARTICULAR FONT, STYLE, SIZE, OR COLOR.

THE ENGLISH TRANSLATION OF "CON GARRA" IN THE MARK IS "PUNCHY".

FOR PURSES; WALLETS; UMBRELLAS; KNAPSACKS AND BACKPACKS; TOTE BAGS; BOOK BAGS; SCHOOL BAGS; OVERNIGHT BAGS; BEACH BAGS; FANNY PACKS; HANDBAGS; SPORTS BAGS; TRAVEL BAGS; TOILETRY BAGS SOLD EMPTY; LUGGAGE; BRIEFCASES; CLOTHING FOR ANIMALS; KEY CASES OF LEATHER OR IMITATION LEATHER (U.S. CLS. 1, 2, 3, 22 AND 41).

JANICE L. MCMORROW, EXAMINING ATTORNEY

CLASS 18—(Continued).

SN 85-474,575. SOURCE INTERLINK MAGAZINES, LLC, EL SEGUNDO, CA. FILED 11-16-2011.

MUD LIFE

THE MARK CONSISTS OF STANDARD CHARACTERS WITHOUT CLAIM TO ANY PARTICULAR FONT, STYLE, SIZE, OR COLOR.

OWNER OF U.S. REG. NO. 3,748,352.
FOR ALL-PURPOSE CARRYING BAGS; BACKPACKS; PURSES; WALLETS (U.S. CLS. 1, 2, 3, 22 AND 41).
FONG HSU, EXAMINING ATTORNEY

SN 85-488,251. HERMES INTERNATIONAL, 75008 PARIS, FRANCE, FILED 12-6-2011.

ETRIBELT

THE MARK CONSISTS OF STANDARD CHARACTERS WITHOUT CLAIM TO ANY PARTICULAR FONT, STYLE, SIZE, OR COLOR.

PRIORITY CLAIMED UNDER SEC. 44(D) ON FRANCE APPLICATION NO. 113841782, FILED 6-27-2011, REG. NO. 113841782, DATED 6-27-2011, EXPIRES 6-27-2021.

THE WORDING "ETRIBELT" HAS NO MEANING IN A FOREIGN LANGUAGE.

FOR GOODS MADE OF LEATHER AND IMITATIONS OF LEATHER, NAMELY, HANDBAGS, TRAVELLING BAGS, RUCKSACKS, SCHOOL SATCHELS AND SCHOOL BAGS, BEACH BAGS, SHOPPING BAGS MADE OF CANVAS, LEATHER AND TEXTILE, GARMENT BAGS FOR TRAVEL, BAGS FOR SPORT, WHEELED SHOPPING BAGS, LEATHER SACKS AND POUCHES FOR PACKAGING, POCKET WALLETS, PURSES, BUSINESS CARD CASES, CREDIT CARD CASES, ATTACHÉ-CASES, BRIEFCASES, KEY CASES IN LEATHER, TRUNKS AND SUITCASES, TOILETRY BAGS SOLD EMPTY, VANITY CASES SOLD EMPTY, HANDBAGS FOR EVENING (U.S. CLS. 1, 2, 3, 22 AND 41).

BRIAN CALLAGHAN, EXAMINING ATTORNEY

CLASS 19—NON-METALLIC BUILDING MATERIALS

SN 79-108,064. G.I.GAR SRL, ITALY, FILED 8-11-2011.

GENIA

THE MARK CONSISTS OF STANDARD CHARACTERS WITHOUT CLAIM TO ANY PARTICULAR FONT, STYLE, SIZE, OR COLOR.

OWNER OF INTERNATIONAL REGISTRATION 1104002 DATED 8-11-2011, EXPIRES 8-11-2021.

FOR WOODEN DOORS, DOORS OF GLASS, WOODEN WINDOWS AND SHUTTERS, WOODEN FRAMES FOR WINDOWS AND DOORS (U.S. CLS. 1, 12, 33 AND 50).
WILLIAM ROSSMAN, EXAMINING ATTORNEY

SN 85-163,324. LITELINE CORPORATION, BRAMPTON, ONTARIO, CANADA, FILED 10-28-2010.

STUCCO STOPPER

THE MARK CONSISTS OF STANDARD CHARACTERS WITHOUT CLAIM TO ANY PARTICULAR FONT, STYLE, SIZE, OR COLOR.

PRIORITY CLAIMED UNDER SEC. 44(D) ON CANADA APPLICATION NO. 1499740, FILED 10-14-2010, REG. NO. TMA813604, DATED 12-7-2011, EXPIRES 12-7-2026.

NO CLAIM IS MADE TO THE EXCLUSIVE RIGHT TO USE "STUCCO", APART FROM THE MARK AS SHOWN.

FOR NON-METAL CONSTRUCTION MATERIALS, NAMELY, PROTECTIVE COVERS TEMPORARILY APPLIED TO RECESSED LIGHTING FIXTURES FOR PURPOSES OF PROTECTING THE LIGHT FIXTURES DURING STUCCO APPLICATION (U.S. CLS. 1, 12, 33 AND 50).

JIM RINGLE, EXAMINING ATTORNEY

SN 85-301,721. MARINE FLOATS CORPORATION, TACOMA, WA. FILED 4-21-2011.

ENVIROGUARD COVERED MOORAGE

THE MARK CONSISTS OF STANDARD CHARACTERS WITHOUT CLAIM TO ANY PARTICULAR FONT, STYLE, SIZE, OR COLOR.

NO CLAIM IS MADE TO THE EXCLUSIVE RIGHT TO USE "COVERED MOORAGE", APART FROM THE MARK AS SHOWN.

FOR NON-METAL FLOATING DOCKS AND PIERS; NON-METAL COMPONENTS USED IN THE CONSTRUCTION OF NON-METAL FLOATING DOCKS, NAMELY, RAMPS AND FLOATS FOR DOCKS; PREFABRICATED NON-METAL BUILDINGS, NAMELY, MARINAS AND BOAT HOUSES (U.S. CLS. 1, 12, 33 AND 50).

FIRST USE 11-27-2009; IN COMMERCE 11-27-2009.
ELIZABETH HUGHITT, EXAMINING ATTORNEY

CLASS 19—(Continued).

SN 85-344,312. THREE RIVERS MARINE & RAIL TERMINALS, L.P., CHARLEROI, PA. FILED 6-13-2011.

MOCHA STONE

THE MARK CONSISTS OF STANDARD CHARACTERS WITHOUT CLAIM TO ANY PARTICULAR FONT, STYLE, SIZE, OR COLOR.

NO CLAIM IS MADE TO THE EXCLUSIVE RIGHT TO USE "STONE", APART FROM THE MARK AS SHOWN.
SEC. 2(F).

FOR DECORATIVE STONE (U.S. CLS. 1, 12, 33 AND 50).

FIRST USE 6-1-2003; IN COMMERCE 6-1-2003.
BARBARA GAYNOR, EXAMINING ATTORNEY

SN 85-447,271. INNOVATIVE MORTAR SOLUTIONS, INC., RICHMOND, TX. FILED 10-13-2011.

TRUEMORTAR

THE MARK CONSISTS OF STANDARD CHARACTERS WITHOUT CLAIM TO ANY PARTICULAR FONT, STYLE, SIZE, OR COLOR.

FOR MORTAR MIX (U.S. CLS. 1, 12, 33 AND 50).

FIRST USE 4-0-2011; IN COMMERCE 4-0-2011.
LEIGH CAROLINE CASE, EXAMINING ATTORNEY

SN 85-447,490. WEYERHAEUER NR COMPANY, FEDERAL WAY, WA. FILED 10-14-2011.

DOWN PORE

THE MARK CONSISTS OF STANDARD CHARACTERS WITHOUT CLAIM TO ANY PARTICULAR FONT, STYLE, SIZE, OR COLOR.

FOR NON-METALLIC BUILDING MATERIALS, NAMELY, ORIENTED STRAND BOARD PANELS (U.S. CLS. 1, 12, 33 AND 50).

KATHERINE STOIDES, EXAMINING ATTORNEY

CLASS 19—(Continued).

SN 85-447,574. CREATIVE STONE MFG., INC., FONTANA, CA. FILED 10-14-2011.

PRO-LEDGE

THE MARK CONSISTS OF STANDARD CHARACTERS WITHOUT CLAIM TO ANY PARTICULAR FONT, STYLE, SIZE, OR COLOR.

FOR MANUFACTURED STONE VENEER FOR BUILDING AND CONSTRUCTION PURPOSES (U.S. CLS. 1, 12, 33 AND 50).

FIRST USE 7-0-2011; IN COMMERCE 7-0-2011.
BRIAN PINO, EXAMINING ATTORNEY

SN 85-456,840. OWENS CORNING INTELLECTUAL CAPITAL, LLC, TOLEDO, OH. FILED 10-26-2011.

PROEDGE

THE MARK CONSISTS OF STANDARD CHARACTERS WITHOUT CLAIM TO ANY PARTICULAR FONT, STYLE, SIZE, OR COLOR.

FOR NON-METAL ROOFING SHINGLES (U.S. CLS. 1, 12, 33 AND 50).

HENRY S. ZAK, EXAMINING ATTORNEY

SN 85-461,643. OVERHEAD DOOR CORPORATION, LEWISVILLE, TX. FILED 11-1-2011.

BRETON

THE MARK CONSISTS OF STANDARD CHARACTERS WITHOUT CLAIM TO ANY PARTICULAR FONT, STYLE, SIZE, OR COLOR.

FOR NON-METAL GARAGE DOORS (U.S. CLS. 1, 12, 33 AND 50).

SAIMA MAKHDOOM, EXAMINING ATTORNEY

CLASS 19—(Continued).

SN 85-517,025. OWENS CORNING INTELLECTUAL CAPITAL, LLC, TOLEDO, OH. FILED 1-16-2012.

THE RIGHT CHOICE

THE MARK CONSISTS OF STANDARD CHARACTERS WITHOUT CLAIM TO ANY PARTICULAR FONT, STYLE, SIZE, OR COLOR.

FOR NON-METAL ROOFING SHINGLES (U.S. CLS. 1, 12, 33 AND 50).

HENRY S. ZAK, EXAMINING ATTORNEY

CLASS 20—FURNITURE AND ARTICLES NOT OTHERWISE CLASSIFIED

SN 77-917,847. ACME FURNITURE INDUSTRY, INC., CITY OF INDUSTRY, CA. FILED 1-22-2010.

ACME FURNITURE

THE MARK CONSISTS OF STANDARD CHARACTERS WITHOUT CLAIM TO ANY PARTICULAR FONT, STYLE, SIZE, OR COLOR.

NO CLAIM IS MADE TO THE EXCLUSIVE RIGHT TO USE "FURNITURE", APART FROM THE MARK AS SHOWN.

FOR FURNITURE (U.S. CLS. 2, 13, 22, 25, 32 AND 50).
FIRST USE 1-22-2010; IN COMMERCE 1-22-2010.
JIM RINGLE, EXAMINING ATTORNEY

SN 77-982,955. SUNTON ENTERPRISES INC, MABANE, NC. FILED 2-23-2010.

Lazzaro

THE MARK CONSISTS OF STANDARD CHARACTERS WITHOUT CLAIM TO ANY PARTICULAR FONT, STYLE, SIZE, OR COLOR.

FOR SOFAS (U.S. CLS. 2, 13, 22, 25, 32 AND 50).
FIRST USE 7-0-2010; IN COMMERCE 7-0-2010.

APRIL HESIK, EXAMINING ATTORNEY

CLASS 20—(Continued).

SN 79-093,522. LA CORNUE, FRANCE, FILED 12-15-2010.

Domaines Culinaires La Cornue

THE MARK CONSISTS OF STANDARD CHARACTERS WITHOUT CLAIM TO ANY PARTICULAR FONT, STYLE, SIZE, OR COLOR.

PRIORITY DATE OF 6-17-2010 IS CLAIMED.

OWNER OF INTERNATIONAL REGISTRATION 1067369 DATED 12-15-2010, EXPIRES 12-15-2020.

OWNER OF U.S. REG. NOS. 1,552,759, 2,396,947 AND 2,720,841.

NO CLAIM IS MADE TO THE EXCLUSIVE RIGHT TO USE "DOMAINES CULINAIRES", APART FROM THE MARK AS SHOWN.

THE ENGLISH TRANSLATION OF "DOMAINES CULINAIRES LA CORNUE" IN THE MARK IS "CULINARY SPACE THE RETORT".

FOR FURNITURE, NAMELY, KITCHEN FURNITURE, SIDEBOARDS, TABLES, CHOPPING-BLOCKS, CHAIRS, OFFICE FURNITURE IN THE NATURE OF TABLES, MIRRORS, FRAMES EXCEPT BUILDING FRAMES, WORKS OF ART OF WOOD, CORK, REED, CANE, WICKER, HORN, BONE, IVORY, WHALEBONE, SHELL, AMBER, MOTHER-OF-PEARL, MEERSCHAUM, AND SUBSTITUTES FOR ALL THESE MATERIALS AND OF PLASTICS, DECORATIVE OBJECTS IN THE NATURE OF STATUETTES OF WOOD, CORK, REED, CANE, WICKER, HORN, BONE, IVORY, WHALEBONE, SHELL, AMBER, MOTHER-OF-PEARL, MEERSCHAUM, AND SUBSTITUTES FOR ALL THESE MATERIALS AND OF PLASTICS, NON-METAL BOTTLE BINS, TEA TROLLEYS, DISPLAY CASES AND CRATES OF WOOD AND PLASTIC, STRAWS FOR DRINKING, BASKETS NOT OF METAL, UMBRELLA STANDS, FIXED TOWEL DISPENSERS NOT OF METAL, TABLE TOPS, PACKAGING CONTAINERS OF PLASTICS, DECORATIVE WALL PLAQUES NOT OF TEXTILE MADE OF BONE, IVORY, PLASTER, PLASTIC, WAX AND WOOD, WORKS OF ART AND FIGURINES MADE FROM BONE, IVORY, PLASTER, PLASTIC, WAX AND WOOD, HAT RACKS, POT RACKS, STORAGE RACKS, SHELVING, FURNITURE PARTITIONS OF WOOD, PACKAGING FOR BOTTLES OF WOOD IN THE NATURE OF WOOD CRATES, CUSHIONS, KNIFE HANDLES NOT OF METAL, HOOKS NOT OF METAL FOR CLOTHES RAILS, PLACARDS OF WOOD OR PLASTICS, BOTTLE CASINGS OF WOOD, FITTINGS FOR FURNITURE NOT OF METAL, MAGAZINE RACKS (U.S. CLS. 2, 13, 22, 25, 32 AND 50).

TRACY FLETCHER, EXAMINING ATTORNEY

CLASS 20—(Continued).

SN 85-052,416. JOHANNA FOODS, INC., FLEMINGTON, NJ, FILED 6-2-2010.



NO CLAIM IS MADE TO THE EXCLUSIVE RIGHT TO USE "WIDE MOUTH", APART FROM THE MARK AS SHOWN.

THE MARK CONSISTS OF THE TWO-DIMENSIONAL TOP OF A CIRCULAR CONTAINER CLOSURE CAP WITH A RING OF CONNECTED DOTS AROUND THE CAP BORDER AND THE PHRASE "E Z POUR", ENCIRCLED BY TWO ITERATIONS OF THE PHRASE "WIDE MOUTH", IN STYLIZED FONT ON THE TOP.

FOR ARTICLE CONSTITUTING A BEVERAGE CONTAINER CLOSURE CAP MADE OF PLASTIC (U.S. CLS. 2, 13, 22, 25, 32 AND 50).

FIRST USE 2-11-2010; IN COMMERCE 2-11-2010.

JULIE GUTTADAURO, EXAMINING ATTORNEY

SN 85-128,132. CJ 4DPLEX CO., LTD., SEOUL, REPUBLIC OF KOREA, FILED 9-13-2010.

4DPLEX

SN 79-105,066. RADICE S.N.C., ITALY, FILED 10-21-2011.

PRIORITY DATE OF 5-4-2011 IS CLAIMED.

OWNER OF INTERNATIONAL REGISTRATION 1079978 DATED 5-10-2011, EXPIRES 5-10-2021.

FOR FURNITURE, MIRRORS, PICTURE FRAMES (U.S. CLS. 2, 13, 22, 25, 32 AND 50).

MATTHEW EINSTEIN, EXAMINING ATTORNEY

THE MARK CONSISTS OF STANDARD CHARACTERS WITHOUT CLAIM TO ANY PARTICULAR FONT, STYLE, SIZE, OR COLOR.

PRIORITY CLAIMED UNDER SEC. 44(D) ON REPUBLIC OF KOREA APPLICATION NO. 402010-47706, FILED 9-10-2010, REG. NO. 0889033, DATED 11-8-2011, EXPIRES 11-8-2021.

FOR THEATER SEATS FOR MOVIES AUDIENCE EFFECTS; THEATER SEATS; THEATER SEATS FOR MOVIES AUDIENCE EFFECTS IN CINEMAS WITH SPECIAL EFFECTS SUCH AS WIND, SCENT, WATER SPRAY, MOTION, VIBRATION, SMOKE, BUBBLE, LASER OR FLASH; NON-METAL MEMORIAL TABLETS OF BONE, IVORY, PLASTER, PLASTIC, WAX, WOOD, SHELL, AMBER; STATUES OF WOOD, WAX, PLASTER OR PLASTIC (U.S. CLS. 2, 13, 22, 25, 32 AND 50).

RON FAIRBANKS, EXAMINING ATTORNEY

CLASS 20—(Continued).

SN 85-188,275. FLETCHER CAMERON DESIGN LLC, GUILFORD, CT. FILED 12-1-2010.



NO CLAIM IS MADE TO THE EXCLUSIVE RIGHT TO USE "KITCHEN", APART FROM THE MARK AS SHOWN. THE MARK CONSISTS OF THE STYLIZED WORDS "BOX KITCHEN" INSIDE A SQUARE DESIGN.

FOR KITCHEN CABINETS (U.S. CLS. 2, 13, 22, 25, 32 AND 50).

FIRST USE 5-15-2010; IN COMMERCE 5-15-2010. PRISCILLA MILTON, EXAMINING ATTORNEY

SN 85-229,884. INTERNATIONAL WINDOW COVERINGS, INC., DBA INTERNATIONAL PRODUCT GROUP, STAFFORD, TX. AND J & L INDUSTRIES, INC., DBA J & L DISTRIBUTORS, STAFFORD, TX. FILED 1-31-2011.

Underbead

THE MARK CONSISTS OF STANDARD CHARACTERS WITHOUT CLAIM TO ANY PARTICULAR FONT, STYLE, SIZE, OR COLOR.

FOR INDOOR BLINDS; INDOOR WINDOW BLINDS; SLATTED INDOOR BLINDS; SLATTED INDOOR BLINDS FOR WINDOWS; WINDOW BLINDS (U.S. CLS. 2, 13, 22, 25, 32 AND 50).

FIRST USE 11-30-1999; IN COMMERCE 11-30-1999. MARK SPARACINO, EXAMINING ATTORNEY

SN 85-260,361. WHITE DOVE MATTRESS, LTD., CLEVELAND, OH. FILED 3-7-2011.

OXYGEN

THE MARK CONSISTS OF STANDARD CHARACTERS WITHOUT CLAIM TO ANY PARTICULAR FONT, STYLE, SIZE, OR COLOR.

FOR MATTRESSES; PILLOWS (U.S. CLS. 2, 13, 22, 25, 32 AND 50).

KEVIN CORWIN, EXAMINING ATTORNEY

CLASS 20—(Continued).

SN 85-286,115. VALCENT USA, INC., CARSON CITY, NV. FILED 4-5-2011.

ALTERRUS

THE MARK CONSISTS OF STANDARD CHARACTERS WITHOUT CLAIM TO ANY PARTICULAR FONT, STYLE, SIZE, OR COLOR.

FOR VERTICAL PLANTING CONTAINERS MADE PRIMARILY OF PLASTIC FOR GROWING PLANTS IN A HIGH DENSITY ENVIRONMENT FOR COMMERCIAL OR INDUSTRIAL PURPOSES (U.S. CLS. 2, 13, 22, 25, 32 AND 50).

LAURIE KAUFMAN, EXAMINING ATTORNEY

SN 85-286,126. VALCENT USA, INC., CARSON CITY, NV. FILED 4-5-2011.

ALTERRUS SYSTEMS

THE MARK CONSISTS OF STANDARD CHARACTERS WITHOUT CLAIM TO ANY PARTICULAR FONT, STYLE, SIZE, OR COLOR.

NO CLAIM IS MADE TO THE EXCLUSIVE RIGHT TO USE "SYSTEMS", APART FROM THE MARK AS SHOWN.

FOR VERTICAL PLANTING CONTAINERS MADE PRIMARILY OF PLASTIC FOR GROWING PLANTS IN A HIGH DENSITY ENVIRONMENT FOR COMMERCIAL OR INDUSTRIAL PURPOSES (U.S. CLS. 2, 13, 22, 25, 32 AND 50).

LAURIE KAUFMAN, EXAMINING ATTORNEY

SN 85-308,658. WENGER CORPORATION, OWATONNA, MN. FILED 4-29-2011.

EDGE

THE MARK CONSISTS OF STANDARD CHARACTERS WITHOUT CLAIM TO ANY PARTICULAR FONT, STYLE, SIZE, OR COLOR.

FOR BUILT-IN STORAGE SYSTEM COMPRISING SHELVES AND CLOTHES RODS, SOLD AS A UNIT FOR USE WITH MUSICAL INSTRUMENTS AND ROBES, UNIFORMS AND OTHER GARMENTS (U.S. CLS. 2, 13, 22, 25, 32 AND 50).

JULIE GUTTADAURO, EXAMINING ATTORNEY

CLASS 20—(Continued).

SN 85-324,335. HORIZON GROUP USA, INC., WARREN, NJ.
FILED 5-18-2011.

SCHOOL FX

THE MARK CONSISTS OF STANDARD CHARACTERS WITHOUT CLAIM TO ANY PARTICULAR FONT, STYLE, SIZE, OR COLOR.

NO CLAIM IS MADE TO THE EXCLUSIVE RIGHT TO USE "SCHOOL", APART FROM THE MARK AS SHOWN, FOR PRESENTATION BOARDS; DESKS; PICTURE FRAMES; NON-METAL AND NON-LEATHER KEY CHAINS (U.S. CLS. 2, 13, 22, 25, 32 AND 50).
REGINA DRUMMOND, EXAMINING ATTORNEY

SN 85-340,160. SERTA, INC., HOFFMAN ESTATES, IL.
FILED 6-7-2011.

IGEL

THE MARK CONSISTS OF STANDARD CHARACTERS WITHOUT CLAIM TO ANY PARTICULAR FONT, STYLE, SIZE, OR COLOR.

FOR MATTRESS COMPONENT, NAMELY, A VISCOUS GEL POLYMER SOLD AS A PART OF THE MATTRESS (U.S. CLS. 2, 13, 22, 25, 32 AND 50).
RENEE MCCRAY, EXAMINING ATTORNEY

SN 85-377,992. METROPOLIS MANUFACTURING, INC.,
LOS ANGELES, CA. FILED 7-22-2011.

VAUGHAN BENZ

THE MARK CONSISTS OF STANDARD CHARACTERS WITHOUT CLAIM TO ANY PARTICULAR FONT, STYLE, SIZE, OR COLOR.

THE NAME "VAUGHAN BENZ" DOES NOT IDENTIFY A LIVING INDIVIDUAL.
FOR FURNITURE; MIRRORS; AND PILLOWS (U.S. CLS. 2, 13, 22, 25, 32 AND 50).
FIRST USE 0-0-1991; IN COMMERCE 0-0-1991.
SUNG IN, EXAMINING ATTORNEY

CLASS 20—(Continued).

SN 85-398,151. GF HEALTH PRODUCTS, INC., ATLANTA, GA. FILED 8-15-2011.

Basic American Medical Products

THE MARK CONSISTS OF STANDARD CHARACTERS WITHOUT CLAIM TO ANY PARTICULAR FONT, STYLE, SIZE, OR COLOR.

NO CLAIM IS MADE TO THE EXCLUSIVE RIGHT TO USE "MEDICAL PRODUCTS", APART FROM THE MARK AS SHOWN.

SEC. 2(F).
FOR BED FRAMES; BED HEADBOARDS; BED RAILS; BEDS; FURNITURE PRIMARILY OF METAL, NAMELY, MIRRORS, BED FRAMES, DINING TABLES, COFFEE TABLES, END TABLES, DESKS, DISPLAY CASES, SHELVING, DOG GATES, AND BABY GATES; HOSPITAL BEDS; NON-METAL BED FITTINGS; RODS FOR BEDS (U.S. CLS. 2, 13, 22, 25, 32 AND 50).

FIRST USE 1-1-1989; IN COMMERCE 1-1-1989.
LINDA M. KING, EXAMINING ATTORNEY

SN 85-399,885. COMPOSITE CONTAINERS, LLC, WANDO, SC. FILED 8-17-2011.

STACKSACK

THE MARK CONSISTS OF STANDARD CHARACTERS WITHOUT CLAIM TO ANY PARTICULAR FONT, STYLE, SIZE, OR COLOR.

FOR NON-PAPER AND PRIMARILY NON-METAL PORTABLE SHIPPING CONTAINERS FOR THE TRANSPORTATION AND STORAGE OF MATERIALS IN BULK (U.S. CLS. 2, 13, 22, 25, 32 AND 50).

SUSAN STIGLITZ, EXAMINING ATTORNEY

CLASS 20—(Continued).

SN 85-402,637. CAUTHORN, JACLYNN M., LUCAS, TX.
FILED 8-19-2011.



NO CLAIM IS MADE TO THE EXCLUSIVE RIGHT TO USE "COLLECTION", APART FROM THE MARK AS SHOWN.

THE MARK CONSISTS OF ELEGANT HORSE LOOKING BACK WITH FULL MANE AND TAIL INCLUDING THE WORDS "THE WIND SONG COLLECTION" ENCLOSED IN AN OVAL. TAIL EXTENDS BEYOND THE OVAL ON THE RIGHT HAND SIDE. HORSE IS LOCATED ON THE UPPER MID RIGHT HAND SIDE OF OVAL. THE WORDS "THE WIND SONG COLLECTION" ARE LOCATED IN THE LOWER MID LEFT SIDE OF OVAL AND IS IN CALLIGRAPHY FONT ON THREE LINES. "WIND SONG" IS TWO WORDS, THE "W" AND "S" ARE CAPITALIZED IN "WIND" AND "SONG", AND "SONG" IS STAGGERED UNDERNEATH "WIND".

FOR BLINDS OF REED, RATTAN OR BAMBOO (SUDARE) (U.S. CLS. 2, 13, 22, 25, 32 AND 50).

FIRST USE 1-1-1994; IN COMMERCE 1-1-2009.
NICHOLAS ALTREE, EXAMINING ATTORNEY

SN 85-405,860. MECHOSHADE SYSTEMS, INC., LONG ISLAND CITY, NY. FILED 8-24-2011.

URBANSHADE

THE MARK CONSISTS OF STANDARD CHARACTERS WITHOUT CLAIM TO ANY PARTICULAR FONT, STYLE, SIZE, OR COLOR.

FOR MANUAL AND MOTORIZED WINDOW SHADES; NON-METAL WINDOW SHADE HARDWARE, NAMELY, HOUSINGS, FASCIA, AND SHADECLOTH GUIDES (U.S. CLS. 2, 13, 22, 25, 32 AND 50).

FIRST USE 2-1-2010; IN COMMERCE 2-10-2010.
JOHN DWYER, EXAMINING ATTORNEY

CLASS 20—(Continued).

SN 85-421,092. VAN DAM, HEATHER, WILLOUGHBY, OH.
AND WAKELAND, JENNIFER, WILLOUGHBY, OH.
FILED 9-13-2011.

SQUACKDOODLE

THE MARK CONSISTS OF STANDARD CHARACTERS WITHOUT CLAIM TO ANY PARTICULAR FONT, STYLE, SIZE, OR COLOR.

FOR GENERAL CONSUMER GOODS, NAMELY, HOUSEWARES IN THE NATURE OF PICTURE FRAMES; PILLOWS; WALL DECORATIONS, NAMELY, SOFT SCULPTURE WALL DECORATIONS AND DECORATIVE WOODEN WALL LETTERS FOR SPELLING NAMES AND WORDS; MIRRORS; NON-METAL WALL HOOKS (U.S. CLS. 2, 13, 22, 25, 32 AND 50).

ANDREA K. NADELMAN, EXAMINING ATTORNEY

SN 85-427,038. KEL-TOY, INC., SAN FRANCISCO, CA.
FILED 9-20-2011.

I-Hook Incredible Hook

THE MARK CONSISTS OF STANDARD CHARACTERS WITHOUT CLAIM TO ANY PARTICULAR FONT, STYLE, SIZE, OR COLOR.

NO CLAIM IS MADE TO THE EXCLUSIVE RIGHT TO USE "HOOK", APART FROM THE MARK AS SHOWN.

FOR NON-METAL HOOKS (U.S. CLS. 2, 13, 22, 25, 32 AND 50).

JULIE WATSON, EXAMINING ATTORNEY

CLASS 20—(Continued).

SN 85-435,079. PANAMA JACK INTERNATIONAL, INC., ORLANDO, FL. FILED 9-29-2011.

PANAMA JACK OUTDOOR

THE MARK CONSISTS OF STANDARD CHARACTERS WITHOUT CLAIM TO ANY PARTICULAR FONT, STYLE, SIZE, OR COLOR.

OWNER OF U.S. REG. NOS. 1,325,935, 1,354,252 AND OTHERS.

NO CLAIM IS MADE TO THE EXCLUSIVE RIGHT TO USE "OUTDOOR", APART FROM THE MARK AS SHOWN.

THE NAME(S), PORTRAIT(S), AND/OR SIGNATURE(S) SHOWN IN THE MARK DOES NOT IDENTIFY A PARTICULAR LIVING INDIVIDUAL.

FOR SOFT SCULPTURE WALL DECORATIONS; WALL PLAQUES MADE OF PLASTIC OR WOOD; INTERIOR WINDOW BLINDS; STOOLS; WALL DECORATIONS MADE OF WOOD, WAX, PLASTER OR PLASTIC; BEACH CHAIRS; ARMCHAIRS; FURNITURE, OUTDOOR FURNITURE, MIRRORS, PICTURE FRAMES, HAND FANS, PILLOWS, PLASTIC BOXES, WOOD BOXES; BAMBOO BLINDS; BATHROOM VANITIES; BEDS, BENCHES, BUSTS OF PLASTIC, CHAIRS, COLD CAST RESIN FIGURINES, CUSHIONS; BUSTS, SCULPTURES AND FIGURINES OF BONE, IVORY, PLASTER, PLASTIC, WAX AND WOOD; MAGAZINE RACKS; SCREENS; WOOD CARVINGS; WIND CHIMES; WINE RACKS; BABY CHANGING TABLES; BABY CHANGING MATS; BOOKCASES; BOTTLE RACKS; BUNK BEDS; COAT RACKS; COTS; NON-METAL KEY RINGS; SLEEPING BAGS; PORTABLE OUTDOOR PRIVACY SCREENS FOR SUNBATHING; BATH PILLOWS; BED PILLOWS; FUTONS, FUTON MATTRESSES, BEDS, MATTRESSES, SPRING MATTRESSES, BOX SPRINGS, MATTRESS FOUNDATIONS, BOLSTERS; BED FRAMES; BED HEADBOARDS; BED RAILS; BED RESTS; BEDS FOR HOUSEHOLD PETS; FOOT RESTS, OTTOMANS, FOOT STOOLS AND BEAN BAG CHAIRS (U.S. CLS. 2, 13, 22, 25, 32 AND 50).

COLLEEN DOMBROW, EXAMINING ATTORNEY

CLASS 20—(Continued).

SN 85-435,225. PANAMA JACK INTERNATIONAL, INC., ORLANDO, FL. FILED 9-29-2011.

PANAMA JACK FURNITURE

THE MARK CONSISTS OF STANDARD CHARACTERS WITHOUT CLAIM TO ANY PARTICULAR FONT, STYLE, SIZE, OR COLOR.

OWNER OF U.S. REG. NOS. 1,325,935, 1,354,252 AND OTHERS.

NO CLAIM IS MADE TO THE EXCLUSIVE RIGHT TO USE "FURNITURE", APART FROM THE MARK AS SHOWN.

THE NAME(S), PORTRAIT(S), AND/OR SIGNATURE(S) SHOWN IN THE MARK DOES NOT IDENTIFY A PARTICULAR LIVING INDIVIDUAL.

FOR SOFT SCULPTURE WALL DECORATIONS; WALL PLAQUES MADE OF PLASTIC OR WOOD; INTERIOR WINDOW BLINDS; STOOLS; WALL DECORATIONS MADE OF WOOD, WAX, PLASTER OR PLASTIC; BEACH CHAIRS; ARMCHAIRS; FURNITURE, OUTDOOR FURNITURE, MIRRORS, PICTURE FRAMES, HAND FANS, PILLOWS, PLASTIC BOXES, WOOD BOXES; BAMBOO BLINDS; BATHROOM VANITIES; BEDS, BENCHES, BUSTS OF PLASTIC, CHAIRS, COLD CAST RESIN FIGURINES, CUSHIONS; BUSTS, SCULPTURES AND FIGURINES OF BONE, IVORY, PLASTER, PLASTIC, WAX AND WOOD; MAGAZINE RACKS; SCREENS; WOOD CARVINGS; WIND CHIMES; WINE RACKS; BABY CHANGING TABLES; BABY CHANGING MATS; BOOKCASES; BOTTLE RACKS; BUNK BEDS; COAT RACKS; COTS; NON-METAL KEY RINGS; SLEEPING BAGS; PORTABLE OUTDOOR PRIVACY SCREENS FOR SUNBATHING; BATH PILLOWS; BED PILLOWS; FUTONS, FUTON MATTRESSES, BEDS, MATTRESSES, SPRING MATTRESSES, BOX SPRINGS, MATTRESS FOUNDATIONS, BOLSTERS; BED FRAMES; BED HEADBOARDS; BED RAILS; BED RESTS; BEDS FOR HOUSEHOLD PETS; FOOT RESTS, OTTOMANS, FOOT STOOLS AND BEAN BAG CHAIRS (U.S. CLS. 2, 13, 22, 25, 32 AND 50).

COLLEEN DOMBROW, EXAMINING ATTORNEY

SN 85-440,472. LEBOFF, LYNN, FORT LAUDERDALE, FL. FILED 10-6-2011.

FIL-A-FRAME

THE MARK CONSISTS OF STANDARD CHARACTERS WITHOUT CLAIM TO ANY PARTICULAR FONT, STYLE, SIZE, OR COLOR.

FOR DISPLAY CASES FOR DECORATIVE ITEMS (U.S. CLS. 2, 13, 22, 25, 32 AND 50).

ROBIN CHOSID, EXAMINING ATTORNEY

CLASS 20—(Continued).

SN 85-445,422. ERIC ARMIN INC., DBA EAI EDUCATION, OAKLAND, NJ. FILED 10-12-2011.

NEATSEAT

THE MARK CONSISTS OF STANDARD CHARACTERS WITHOUT CLAIM TO ANY PARTICULAR FONT, STYLE, SIZE, OR COLOR.

FOR BOOK AND EDUCATIONAL IMPLEMENTS HOLDER ATTACHED TO CHAIR OF CHILD'S DESK (U.S. CLS. 2, 13, 22, 25, 32 AND 50).

DAVID MURRAY, EXAMINING ATTORNEY

CLASS 20—(Continued).

SN 85-446,723. HERMAN MILLER, INC., ZEELAND, MI. FILED 10-13-2011.

EVOLVING THE ART AND SCIENCE OF SEATING

THE MARK CONSISTS OF STANDARD CHARACTERS WITHOUT CLAIM TO ANY PARTICULAR FONT, STYLE, SIZE, OR COLOR.

FOR OFFICE FURNITURE (U.S. CLS. 2, 13, 22, 25, 32 AND 50).

JAY FLOWERS, EXAMINING ATTORNEY

SN 85-446,489. HUNTER DOUGLAS INC., PEARL RIVER, NY. FILED 10-13-2011.

PROMINENCE

THE MARK CONSISTS OF STANDARD CHARACTERS WITHOUT CLAIM TO ANY PARTICULAR FONT, STYLE, SIZE, OR COLOR.

FOR INDOOR BLINDS; WINDOW SHADES (U.S. CLS. 2, 13, 22, 25, 32 AND 50).

CHRISTOPHER SIDOTI, EXAMINING ATTORNEY

SN 85-446,831. DACO LIMITED PARTNERSHIP, DBA DAUPHIN NORTH AMERICA, BOONTON, NJ. FILED 10-13-2011.

BLEND

THE MARK CONSISTS OF STANDARD CHARACTERS WITHOUT CLAIM TO ANY PARTICULAR FONT, STYLE, SIZE, OR COLOR.

FOR A FURNITURE SYSTEM, NAMELY TABLES, CHAIRS AND COMPONENTS THEREFORE (U.S. CLS. 2, 13, 22, 25, 32 AND 50).

C. DIONNE CLYBURN, EXAMINING ATTORNEY

SN 85-446,577. VENDOR DEVELOPMENT GROUP, INC., MINNEAPOLIS, MN. FILED 10-13-2011.

GRAND WATERS

THE MARK CONSISTS OF STANDARD CHARACTERS WITHOUT CLAIM TO ANY PARTICULAR FONT, STYLE, SIZE, OR COLOR.

FOR DINING TABLES AND CHAIRS, BARSTOOLS, TV CONSOLES, WINE RACKS, BOOK SHELVES, END TABLES, COFFEE TABLES, DESKS AND RECLINERS (U.S. CLS. 2, 13, 22, 25, 32 AND 50).

SARA BENJAMIN, EXAMINING ATTORNEY

SN 85-446,837. HUNTER DOUGLAS INC., PEARL RIVER, NY. FILED 10-13-2011.

**STYLISH SOLUTIONS,
AFFORDABLY**

THE MARK CONSISTS OF STANDARD CHARACTERS WITHOUT CLAIM TO ANY PARTICULAR FONT, STYLE, SIZE, OR COLOR.

FOR INDOOR BLINDS; WINDOW SHADES (U.S. CLS. 2, 13, 22, 25, 32 AND 50).

CHRISTOPHER SIDOTI, EXAMINING ATTORNEY

CLASS 20—(Continued).

SN 85-446,854. HUNTER DOUGLAS INC., PEARL RIVER, NY. FILED 10-13-2011.

PALETTE

THE MARK CONSISTS OF STANDARD CHARACTERS WITHOUT CLAIM TO ANY PARTICULAR FONT, STYLE, SIZE, OR COLOR.
OWNER OF U.S. REG. NO. 2,186,141.
FOR INDOOR BLINDS; WINDOW SHADES (U.S. CLS. 2, 13, 22, 25, 32 AND 50).
CHRISTOPHER SIDOTI, EXAMINING ATTORNEY

CLASS 20—(Continued).

SN 85-447,527. LLOYDS IP HOLDINGS LLC, POMONA, CA. FILED 10-14-2011.

DUAL-STRONG

THE MARK CONSISTS OF STANDARD CHARACTERS WITHOUT CLAIM TO ANY PARTICULAR FONT, STYLE, SIZE, OR COLOR.
FOR SUPPORT CABINETS FOR WATER RECREATIONAL APPARATUSES, NAMELY, PORTABLE SPAS IN THE NATURE OF HOT TUBS AND/OR HEATED POOLS (U.S. CLS. 2, 13, 22, 25, 32 AND 50).
KIMBERLY PERRY, EXAMINING ATTORNEY

SN 85-447,356. SWISSRAEL, LLC, NEW LENOX, IL. FILED 10-14-2011.

PRESS IT TO UNDRRESS IT

THE MARK CONSISTS OF STANDARD CHARACTERS WITHOUT CLAIM TO ANY PARTICULAR FONT, STYLE, SIZE, OR COLOR.
FOR CLOTHES HANGERS (U.S. CLS. 2, 13, 22, 25, 32 AND 50).
KAREN K. BUSH, EXAMINING ATTORNEY

SN 85-447,702. BAKER MANUFACTURING COMPANY, INC., PINEVILLE, LA. FILED 10-14-2011.

ANIMATE

THE MARK CONSISTS OF STANDARD CHARACTERS WITHOUT CLAIM TO ANY PARTICULAR FONT, STYLE, SIZE, OR COLOR.
FOR HEIGHT-ADJUSTABLE TABLES (U.S. CLS. 2, 13, 22, 25, 32 AND 50).
SUSAN STIGLITZ, EXAMINING ATTORNEY

SN 85-447,376. SWISSRAEL, LLC, NEW LENOX, IL. FILED 10-14-2011.



THE MARK CONSISTS OF A DEPICTION OF A SHIELD WITH A CROSS INSIDE, A HOOK POINTING TO THE LEFT ON THE TOP OF THE SHIELD.
FOR CLOTHES HANGERS (U.S. CLS. 2, 13, 22, 25, 32 AND 50).
HEATHER THOMPSON, EXAMINING ATTORNEY

SN 85-447,936. ELECTRONIC IMAGING SERVICES, INC., DBA VESTCOM RETAIL SOLUTIONS, LITTLE ROCK, AR. FILED 10-14-2011.

AisleWise

THE MARK CONSISTS OF STANDARD CHARACTERS WITHOUT CLAIM TO ANY PARTICULAR FONT, STYLE, SIZE, OR COLOR.
FOR MERCHANDISE DISPLAYS, NAMELY, HANGING MERCHANDISE DISPLAY RACKS (U.S. CLS. 2, 13, 22, 25, 32 AND 50).
RONALD MCMORROW, EXAMINING ATTORNEY

CLASS 20—(Continued).

SN 85-449,487. PARAMOUNT INDUSTRIAL COMPANIES, INC., NORFOLK, VA. FILED 10-18-2011.

DR. MAAS

THE MARK CONSISTS OF STANDARD CHARACTERS WITHOUT CLAIM TO ANY PARTICULAR FONT, STYLE, SIZE, OR COLOR.

THE NAME SHOWN IN THE MARK IDENTIFIES DR. JAMES B. MAAS, WHOSE CONSENT TO REGISTER IS MADE OF RECORD.

FOR MATTRESSES; MATTRESS FOUNDATIONS; BOX SPRINGS (U.S. CLS. 2, 13, 22, 25, 32 AND 50).

CHRISTOPHER BUONGIORNO, EXAMINING ATTORNEY

SN 85-449,694. COMMERSTATION, LLC, SEATTLE, WA. FILED 10-18-2011.

DropStation

THE MARK CONSISTS OF STANDARD CHARACTERS WITHOUT CLAIM TO ANY PARTICULAR FONT, STYLE, SIZE, OR COLOR.

FOR LOCKERS (U.S. CLS. 2, 13, 22, 25, 32 AND 50).

FIRST USE 1-17-2008; IN COMMERCE 1-17-2008.

JOHN WILKE, EXAMINING ATTORNEY

SN 85-449,783. VELORA INC., BENTONVILLE, AR. FILED 10-18-2011.

GLOBAL FRIENDS

THE MARK CONSISTS OF STANDARD CHARACTERS WITHOUT CLAIM TO ANY PARTICULAR FONT, STYLE, SIZE, OR COLOR.

FOR PILLOWS (U.S. CLS. 2, 13, 22, 25, 32 AND 50).

NANCY CLARKE, EXAMINING ATTORNEY

CLASS 20—(Continued).

SN 85-450,339. VALET ORGANIZERS, INC., CAMPBELL, CA. FILED 10-18-2011.



NO CLAIM IS MADE TO THE EXCLUSIVE RIGHT TO USE "CUSTOM CABINETS & CLOSETS", APART FROM THE MARK AS SHOWN.

THE COLOR(S) BLACK, RED, GREY AND WHITE IS/ARE CLAIMED AS A FEATURE OF THE MARK.

THE MARK CONSISTS OF A LARGE BLACK LETTER "V", WITH A RED BOWTIE BETWEEN THE TIPS OF THE "V" AND A WHITE TRIANGULAR AREA WITHIN THE "V", THREE GREY BUTTONS OR STUDS SPACED VERTICALLY BENEATH THE BOWTIE AND WITHIN THE "V", THE WORD "VALET" IN RED BENEATH THE "V", THE WORDS "CUSTOM, CABINETS, & CLOSETS" IN BLACK STACKED BENEATH THE WORD "VALET", AND BLACK HORIZONTAL LINES ABOVE AND BELOW THE WORDING.

FOR BEDROOM FURNITURE; BEDS; CABINETS; CABINETWORK; COMPUTER FURNITURE; COMPUTER KEYBOARD TRAYS; CUSTOM FURNITURE; DESKS; ENTERTAINMENT CENTERS; FOLDING BEDS; FURNITURE; FURNITURE, NAMELY, WALL UNITS; FURNITURE, NAMELY, WARDROBES; OFFICE FURNITURE; PREFABRICATED CLOSET ORGANIZATION SYSTEMS MADE OF WOOD; SHELVES; SHELVES FOR STORAGE; STORAGE AND ORGANIZATION SYSTEMS COMPRISING SHELVES, DRAWERS, CUPBOARDS, BASKETS AND CLOTHES RODS, SOLD AS A UNIT; TABLES; WALL-MOUNTED TOOL RACKS; WORKBENCHES (U.S. CLS. 2, 13, 22, 25, 32 AND 50).

FIRST USE 1-0-2010; IN COMMERCE 1-0-2010.

WILLIAM JACKSON, EXAMINING ATTORNEY

SN 85-450,489. SIMMONS, ROSEMARY L., DBA ROSIE OH!, ORANGE, CA. FILED 10-18-2011.

ROCKIN LOCKER SHELF

THE MARK CONSISTS OF STANDARD CHARACTERS WITHOUT CLAIM TO ANY PARTICULAR FONT, STYLE, SIZE, OR COLOR.

NO CLAIM IS MADE TO THE EXCLUSIVE RIGHT TO USE "LOCKER SHELF", APART FROM THE MARK AS SHOWN.

FOR SHELVING FOR LOCKERS (U.S. CLS. 2, 13, 22, 25, 32 AND 50).

FIRST USE 10-18-2011; IN COMMERCE 10-18-2011.

ELLEN BURNS, EXAMINING ATTORNEY

CLASS 20—(Continued).

SN 85-450,696. HOLLANDER HOME FASHIONS, LLC, BOCA RATON, FL. FILED 10-19-2011.

NEVER FLAT

THE MARK CONSISTS OF STANDARD CHARACTERS WITHOUT CLAIM TO ANY PARTICULAR FONT, STYLE, SIZE, OR COLOR.

OWNER OF U.S. REG. NO. 3,107,498.
FOR MATTRESS TOPPERS, FIBER BEDS, FEATHER BEDS (U.S. CLS. 2, 13, 22, 25, 32 AND 50).
TINA L. SNAPP, EXAMINING ATTORNEY

SN 85-457,523. BAKER MANUFACTURING COMPANY, INC., PINEVILLE, LA. FILED 10-27-2011.

AUGMENT

THE MARK CONSISTS OF STANDARD CHARACTERS WITHOUT CLAIM TO ANY PARTICULAR FONT, STYLE, SIZE, OR COLOR.

FOR HEIGHT-ADJUSTABLE TABLES; TABLES; OFFICE TABLES (U.S. CLS. 2, 13, 22, 25, 32 AND 50).
SUSAN STIGLITZ, EXAMINING ATTORNEY

SN 85-460,409. SUNBEAM PRODUCTS, INC., BOCA RATON, FL. FILED 10-31-2011.



OWNER OF U.S. REG. NOS. 430,571, 4,064,581 AND OTHERS.

THE MARK CONSISTS OF THE LITERAL ELEMENT "SUNBEAM" WITH AN ARCH HAVING TAPERED ENDS WITH ONE TAPERED END CONNECTED TO THE TOP OF THE LETTER "S" IN THE LITERAL ELEMENT AND EXTENDING ACROSS THE TOP OF THE ENTIRE LITERAL ELEMENT.

FOR PEDESTAL AND WALL MOUNTED MIRRORS (U.S. CLS. 2, 13, 22, 25, 32 AND 50).
FIRST USE 9-30-2004; IN COMMERCE 9-30-2004.
JULIE GUTTADAURO, EXAMINING ATTORNEY

CLASS 20—(Continued).

SN 85-463,928. DIXIE CONSUMER PRODUCTS LLC, ATLANTA, GA. FILED 11-3-2011.

EASY TO HOLD. EASY TO LOVE.

THE MARK CONSISTS OF STANDARD CHARACTERS WITHOUT CLAIM TO ANY PARTICULAR FONT, STYLE, SIZE, OR COLOR.

FOR PLASTIC LIDS (U.S. CLS. 2, 13, 22, 25, 32 AND 50).
NANCY CLARKE, EXAMINING ATTORNEY

SN 85-484,884. BAKER MANUFACTURING COMPANY, INC., PINEVILLE, LA. FILED 12-1-2011.

VISO

THE MARK CONSISTS OF STANDARD CHARACTERS WITHOUT CLAIM TO ANY PARTICULAR FONT, STYLE, SIZE, OR COLOR.

THE ENGLISH TRANSLATION OF "VISO" IN THE MARK IS FACE.
FOR HEIGHT-ADJUSTABLE TABLES (U.S. CLS. 2, 13, 22, 25, 32 AND 50).

SUSAN STIGLITZ, EXAMINING ATTORNEY

SN 85-511,681. FLEET WHOLESALE SUPPLY CO., INC., APPLETON, WI. FILED 1-9-2012.



OWNER OF U.S. REG. NOS. 2,121,688, 4,015,022 AND OTHERS.

THE MARK CONSISTS OF A STYLIZED REPRESENTATION OF THE LETTERS "F", "F" BACK-TO-BACK AND A HALF CIRCLE ABOVE THE LEFT LETTER "F".

FOR CAMPING CHAIRS (U.S. CLS. 2, 13, 22, 25, 32 AND 50).

MARY ROSSMAN, EXAMINING ATTORNEY

CLASS 21—HOUSEWARES AND GLASS

SN 79-101,976. DEKORYUM TICARET LIMITED SIRKETI, TURKEY, FILED 6-15-2011.

DecOrium

OWNER OF INTERNATIONAL REGISTRATION 1089176 DATED 6-15-2011, EXPIRES 6-15-2021.

FOR HOUSEHOLD OR KITCHEN UTENSILS, NAMELY, CAKE MOLDS, PLATES, PITCHERS, SAUCE PANS, TRAYS FOR DOMESTIC PURPOSES; BEVERAGE WARE, NAMELY, DRINKING GLASSES, CUPS; ORNAMENTAL DECORATIVE ACCESSORIES, NAMELY, BOWLS, DISHES, FIGURINES AND SCULPTURES ALL MADE OF GLASS (U.S. CLS. 2, 13, 23, 29, 30, 33, 40 AND 50).

GENE MACIOL, EXAMINING ATTORNEY

SN 79-102,401. WONDER CHEF CO., LTD., OSAKA-FU 561-0825, JAPAN, FILED 8-10-2011.



OWNER OF INTERNATIONAL REGISTRATION 1090314 DATED 8-10-2011, EXPIRES 8-10-2021.

THE MARK CONSISTS OF THE WORD "WONDER CHEF" WITH A DESIGN TO THE LEFT CONSISTING OF THE HEAD OF A MAN WEARING A CHEF'S HAT AND A SCARF AROUND THE NECK.

FOR NON-ELECTRIC PRESSURE COOKERS; NON-ELECTRIC COOKING PANS; NON-ELECTRIC COOKING POTS; NON-ELECTRIC FRYING PANS; NON-ELECTRIC PASTA COOKING POTS; NON-ELECTRIC KETTLES (U.S. CLS. 2, 13, 23, 29, 30, 33, 40 AND 50).

MAYUR VAGHANI, EXAMINING ATTORNEY

SN 85-181,945. THE INSTITUTE OF APPLIED PHENOMENOLOGY IN SCIENCE AND TECHNOLOGY, CANAL FULTON, OH. FILED S.R. 11-21-2010; AM. P.R. 7-13-2011.



THE COLOR(S) BLACK, BLUE AND WHITE IS/ARE CLAIMED AS A FEATURE OF THE MARK.

THE MARK CONSISTS OF THE WORDS "DRINK LOCAL DRINK TAP" IN BLACK AND A WATER DROP IN BLUE AND WHITE.

FOR CANTEENS; DRINKING GLASSES; MUGS (U.S. CLS. 2, 13, 23, 29, 30, 33, 40 AND 50).

FIRST USE 7-1-2010; IN COMMERCE 7-1-2010.

DOUGLAS LEE, EXAMINING ATTORNEY

CLASS 21—(Continued).

SN 85-268,940. SEQUOIA GARDEN SUPPLY, INC., DBA CURRENT CULTURE H2O, FRESNO, CA. FILED 3-16-2011.

Under Current

THE MARK CONSISTS OF STANDARD CHARACTERS WITHOUT CLAIM TO ANY PARTICULAR FONT, STYLE, SIZE, OR COLOR.

SEC. 2(F).

FOR HYDROPONIC SYSTEM FOR GROWING PLANTS COMPRISED OF PLANT CULTIVATION TRAYS AND HOLDERS, PUMPS, HOSES, MANIFOLDS, FILTERS, DRAINS AND SEALS; HYDROPONICS SYSTEM IN THE NATURE OF A HYDROPONIC GARDEN KIT FOR HOME USE FOR GROWING PLANTS COMPRISED OF GROWING CONTAINERS AND ALSO INCLUDING HYDROPONIC SUBSTRATES AND DRAIN COMPONENTS (U.S. CLS. 2, 13, 23, 29, 30, 33, 40 AND 50).

FIRST USE 6-1-2004; IN COMMERCE 10-1-2006.

MEGHAN REINHART, EXAMINING ATTORNEY

SN 85-268,967. SEQUOIA GARDEN SUPPLY, INC., DBA CURRENT CULTURE H2O, FRESNO, CA. FILED 3-16-2011.

Current Culture H2O

THE MARK CONSISTS OF STANDARD CHARACTERS WITHOUT CLAIM TO ANY PARTICULAR FONT, STYLE, SIZE, OR COLOR.

SEC. 2(F).

FOR HYDROPONIC SYSTEM FOR GROWING PLANTS COMPRISED OF PLANT CULTIVATION TRAYS AND HOLDERS, PUMPS, HOSES, MANIFOLDS, FILTERS, DRAINS AND SEALS; HYDROPONICS SYSTEM IN THE NATURE OF A HYDROPONIC GARDEN KIT FOR HOME USE FOR GROWING PLANTS COMPRISED OF GROWING CONTAINERS AND ALSO INCLUDING HYDROPONIC SUBSTRATES AND DRAIN COMPONENTS; HYDROPONIC GARDENING EQUIPMENT, NAMELY, PLANT CULTIVATION TRAYS AND HOLDERS (U.S. CLS. 2, 13, 23, 29, 30, 33, 40 AND 50).

FIRST USE 6-1-2004; IN COMMERCE 4-1-2005.

MEGHAN REINHART, EXAMINING ATTORNEY

CLASS 21—(Continued).

SN 85-270,626. ULTRA PET COMPANY, INC., ANDERSON, SC. FILED 3-18-2011.

BAMBOWL

THE MARK CONSISTS OF STANDARD CHARACTERS WITHOUT CLAIM TO ANY PARTICULAR FONT, STYLE, SIZE, OR COLOR.

FOR FEEDING AND DRINKING BOWLS AND DISHES FOR PETS (U.S. CLS. 2, 13, 23, 29, 30, 33, 40 AND 50).

FIRST USE 3-16-2011; IN COMMERCE 3-16-2011.
CHARLOTTE CORWIN, EXAMINING ATTORNEY

SN 85-274,511. MASCOTTE HOLDINGS, INC., NEW YORK, NY. FILED 3-23-2011.

YEEZI

THE MARK CONSISTS OF STANDARD CHARACTERS WITHOUT CLAIM TO ANY PARTICULAR FONT, STYLE, SIZE, OR COLOR.

THE NAME SHOWN IN THE MARK IDENTIFIES KANYE WEST A LIVING INDIVIDUAL, WHOSE CONSENT TO REGISTER IS MADE OF RECORD.

FOR DINNERWARE, CHINA DINNERWARE, CRYSTAL DINNERWARE, BEVERAGeware, AND STEWARWARE; BEVERAGE GLASSWARE AND DRINKING GLASSES; MUGS, CUPS, GOBLETS, BOTTLES AND GLASS STORAGE JARS SOLD EMPTY, BOTTLE SQUEEGEES, VACUUM BOTTLES AND BARWARE, NAMELY, SELTZER BOTTLES; DEWAR BOTTLES AND VESSELS; DRINKING VESSELS AND HEAT-INSULATED VESSELS; BOTTLE STANDS; WINE BOTTLE CRADLES; GLASS STORAGE JARS, INSULATING JARS AND COOKIE JARS; NON-METAL JARS FOR JAMS AND JELLIES MADE OF EARTHENWARE, GLASS, PORCELAIN AND PLASTIC; BEER JUGS; DRINKING STEINS; FLASKS; COASTERS, NOT MADE OF PAPER AND NOT BEING TABLE LINEN, LEATHER COASTERS AND PLASTIC COASTERS; BARWARE, NAMELY, HIGH BALL GLASSES, SHOT GLASSES, COCKTAIL SHAKERS, CORK SCREWS, CORK HOLDERS, BOTTLE OPENERS, TUMBLERS, WINE GOBLETS, CARAFES, DECANTERS, PORTABLE COOLERS FOR BEVERAGES, NAMELY, PORTABLE COOLERS FOR WINE; WINE COOLER STANDS, PITCHERS, BUCKETS AND BEVERAGE STIRRERS; INSULATING SLEEVE HOLDERS FOR BEVERAGE CANS; FOAM DRINK HOLDERS; BREAD BOXES; HOUSEHOLD CONTAINERS FOR FOODS; CONTAINERS FOR HOUSEHOLD OR KITCHEN USE NOT MADE OF PRECIOUS METAL; ALL PURPOSE PORTABLE HOUSEHOLD CONTAINERS; NON-ELECTRIC KITCHEN CONTAINERS NOT MADE OF PRECIOUS METAL; PORTABLE PLASTIC CONTAINERS FOR STORING HOUSEHOLD AND KITCHEN GOODS; CANTEENS; PORTABLE COOLERS, PORTABLE BEVERAGE COOLERS AND BEVERAGE DISPENSERS; PORTABLE ICE CHESTS FOR FOOD AND BEVERAGES; THERMAL INSULATED CONTAINERS FOR FOOD AND BEVERAGES; THERMAL INSULATED TOTE BAGS FOR FOOD AND BEVERAGES; THERMAL INSULATED WRAP FOR CANS TO KEEP THE CONTENTS COLD OR HOT; INSULATING SLEEVE HOLDERS FOR BEVERAGE CANS; SERVIETTE HOLDERS; SERVIETTE RINGS NOT OF PRECIOUS METAL; LUNCH BOXES AND PAILS; TEA KETTLES; COOKING AND KITCHEN

CLASS 21—(Continued).

UTENSILS, NAMELY, CUTTING BOARDS, WIRE BASKETS, STEAMER BASKETS, KITCHEN AND SERVING LADLES, POTS, METAL AND GLASS PANS, PIE PANS, BAKING DISHES, CRUMB BRUSHES, BRUSHES FOR BASTING MEAT AND DISHWASHING BRUSHES, DISH DRYING RACKS, OVEN TO TABLE RACKS, SPICE RACKS, POULTRY RINGS, RECIPE BOXES, CRUETS NOT OF PRECIOUS METAL, AND CRUET STANDS FOR OIL OR VINEGAR NOT OF PRECIOUS METAL; NON-ELECTRIC COFFEE SERVERS, TEA SERVICES, TEA INFUSERS, TEA BALLS, TEA POTS, AND NON-ELECTRIC KITCHEN CONTAINERS, ALL OF THE FOREGOING NOT OF PRECIOUS METAL; BOWLS, PLATES, DISHES AND DISH COVERS; SAUCERS; SERVING PLATTERS; SERVING TRAYS NOT OF PRECIOUS METAL; TRIVETS; SALT AND PEPPER SHAKERS; TOOTHPICKS AND TOOTHPICK HOLDERS; CANISTER SETS; NAPKIN HOLDERS; NAPKIN RINGS NOT OF PRECIOUS METALS; TABLE PLACARD HOLDERS NOT OF PRECIOUS METAL; BOXES FOR DISPENSING PAPER TOWELS; HAIR BRUSHES AND COMBS; BATHROOM HOLDERS FOR HOLDING HAIR BRUSHES AND COMBS; BATHROOM AND BEAUTY PRODUCTS AND ACCESSORIES, NAMELY, DENTAL FLOSS, TOOTH BRUSHES AND TOOTHBRUSH HOLDERS, CUP HOLDERS, BATH BRUSHES, BODY SPONGES, CLEANING SPONGES, FACIAL CLEANING SPONGES, NATURAL SEA SPONGES, LOOFAH SPONGES, EYEBROW, NAIL AND SHAVING BRUSHES, SHAVING BRUSH HOLDERS AND STANDS, SQUEEGEES FOR SHAVING BRUSHES, PLASTIC BATH RACKS, TOILET BRUSHES AND BRUSH HOLDERS; LOTION CONTAINERS SOLD EMPTY FOR DOMESTIC USE; SOAP BOXES, BRACKETS, CONTAINERS, DISHES, DISPENSERS AND HOLDERS; COTTON BALLS AND COTTON BALL DISPENSERS; COSMETIC AND CLOTHES BRUSHES; CLOTHES DRYING RACKS AND CLOTHES PINS; BABY BATHTUBS; BATHROOM GLASS HOLDER NOT OF PRECIOUS METAL; EARRING ORGANIZER BOARD; CANDLE HOLDERS, CANDLE RINGS AND CANDLESTICKS NOT OF PRECIOUS METAL; CANDLE SNUFFERS; NON-ELECTRIC CANDELABRAS, NOT OF PRECIOUS METAL; GLASS BOXES; CERAMIC TISSUE BOX COVERS, RECIPE BOXES AND SANDWICH BOXES; BASKETS MADE OF STRAW, CLOTH, WICKER AND WOOD; FITTED PICNIC BASKETS; PLANT AND FLOWER POTS, BOWLS, BASKETS AND SYRINGES; PLASTIC LIDS FOR PLANT POTS; POT CLEANING BRUSHES; SCRAPING AND SCRUBBING BRUSHES; VASES; FIGURINES MADE OF CHINA, CRYSTAL, EARTHENWARE, GLASS, AND PORCELAIN; WASTE-PAPER BASKETS; TRASH CONTAINERS FOR HOUSEHOLD USE; NON-METAL PIGGY BANKS; SOUVENIR AND DECORATIVE PLATES; PERFUME BURNERS; PERFUME VAPORIZERS AND SPRAYERS SOLD EMPTY; SHOE HORNS, SHOE, DUSTING, FLOOR AND FIREPLACE BRUSHES; GOLF BRUSH AND BRUSHES FOR BILLIARD TABLES; CLEANING CLOTHS, POLISHING CLOTHS, FURNITURE DUSTERS, DUST PANS AND BROOMS; IRONING BOARDS, SHAPED COVERS FOR IRONING BOARDS, AND HOLDERS FOR HOUSEHOLD IRONS (U.S. CLS. 2, 13, 23, 29, 30, 33, 40 AND 50).

CHARISMA HAMPTON, EXAMINING ATTORNEY

SN 85-290,048. STINKY LLC, ELLICOTT CITY, MD. FILED 4-8-2011.

StickyStick

THE MARK CONSISTS OF STANDARD CHARACTERS WITHOUT CLAIM TO ANY PARTICULAR FONT, STYLE, SIZE, OR COLOR.

FOR INSECT TRAPS (U.S. CLS. 2, 13, 23, 29, 30, 33, 40 AND 50).

EDWARD NELSON, EXAMINING ATTORNEY

CLASS 21—(Continued).

SN 85-298,598. RAICH, THOMAS L., PLAINWELL, MI. FILED 4-19-2011.

BREW HAULER

THE MARK CONSISTS OF STANDARD CHARACTERS WITHOUT CLAIM TO ANY PARTICULAR FONT, STYLE, SIZE, OR COLOR.

NO CLAIM IS MADE TO THE EXCLUSIVE RIGHT TO USE "BREW", APART FROM THE MARK AS SHOWN.

FOR HOLDER FOR A BEVERAGE CONTAINER (U.S. CLS. 2, 13, 23, 29, 30, 33, 40 AND 50).

FIRST USE 4-21-1997; IN COMMERCE 4-21-1997.
MICHAEL ENGEL, EXAMINING ATTORNEY

CLASS 21—(Continued).

SN 85-305,561. ALLYSON AMES COMPANY, INC., CORONA DEL MAR, CA. FILED 4-27-2011.

ALLYSON AMES

THE MARK CONSISTS OF STANDARD CHARACTERS WITHOUT CLAIM TO ANY PARTICULAR FONT, STYLE, SIZE, OR COLOR.

THE NAME "ALLYSON AMES" IDENTIFIES A LIVING INDIVIDUAL WHOSE CONSENT IS OF RECORD.

FOR HOUSEHOLD CONTAINERS, NAMELY, COOKIE JARS, PLATES, CUPS, SAUCERS, BOWLS, GLASSES, BAKING DISHES, MIXING BOWLS, SPATULAS, MUGS, CANDY JARS, CUPCAKE TOWERS, DECORATIVE PLATES, TEA SETS, DECORATIVE BOWLS, TEA CUPS, COFFEE MUGS, POTS, PANS, CAKE PANS, COOKIE PANS, SHAPED BAKING PANS, COOKIE CUTTERS, WHISKS, ROLLING PINS, CAKE TOPPERS (U.S. CLS. 2, 13, 23, 29, 30, 33, 40 AND 50).

FIRST USE 1-1-2005; IN COMMERCE 1-1-2011.
JANICE L. MCMORROW, EXAMINING ATTORNEY

SN 85-303,968. NEW AND JOY LLC, LEWES, DE. FILED 4-25-2011.

SN 85-310,501. ALLYSON AMES COMPANY, INC., CORONA DEL MAR, CA. FILED 5-3-2011.



WONDERLICIOUS

THE MARK CONSISTS OF THE STYLIZED LETTERS "N" AND "J" WITH A FOUR-PETAL FLOWER LIKE SYMBOL IN THE OPENING OF THE LETTER "J".

FOR CUP COASTERS NOT OF PAPER AND NOT BEING TABLE LINEN; PLATES; KITCHEN UTENSILS, NAMELY, GRATERS, SIEVES, SPATULAS; POT LIDS; BOWLS; CUTTING BOARD; BAKEWARE; SALT AND PEPPER SHAKERS; ROLLING PINS; CUPS; BOTTLES SOLD EMPTY; GLASS STORAGE JARS; PLASTIC STORAGE CONTAINERS FOR HOUSEHOLD USE; LUNCH PAILS AND LUNCH BOXES; SUSHI ROLLING MATS (U.S. CLS. 2, 13, 23, 29, 30, 33, 40 AND 50).

JANICE KIM, EXAMINING ATTORNEY

THE MARK CONSISTS OF STANDARD CHARACTERS WITHOUT CLAIM TO ANY PARTICULAR FONT, STYLE, SIZE, OR COLOR.

OWNER OF U.S. REG. NO. 3,629,516.

FOR HOUSEHOLD CONTAINERS, NAMELY, COOKIE JARS, PLATES, CUPS, SAUCERS, BOWLS, GLASSES, BAKING DISHES, MIXING BOWLS, SPATULAS, MUGS, CANDY JARS, CUPCAKE TOWERS, DECORATIVE PLATES, TEA SETS, DECORATIVE BOWLS, TEA CUPS, COFFEE MUGS, POTS, PANS, CAKE PANS, COOKIE PANS, SHAPED BAKING PANS, COOKIE CUTTERS, WHISKS, ROLLING PINS, CAKE TOPPERS (U.S. CLS. 2, 13, 23, 29, 30, 33, 40 AND 50).

FIRST USE 1-1-2005; IN COMMERCE 1-1-2011.
JANICE L. MCMORROW, EXAMINING ATTORNEY

CLASS 21—(Continued).

SN 85-312,738. STEPHAN MEMMI, BEVERLY HILLS, CA. FILED 5-4-2011.



NO CLAIM IS MADE TO THE EXCLUSIVE RIGHT TO USE "CUISINE", APART FROM THE MARK AS SHOWN.

THE MARK CONSISTS OF STYLIZED LETTERS "A" AND "C" OVERLAPPED THE AMPERSAND SYMBOL. THE WORDING "ART & CUISINE" IS BELOW THE "A&C" DESIGN IN WHICH THE TRIANGLE AREA OF THE LETTER "A" IN "ART" AND LOWER PORTION OF THE LETTER "E" IN "CUISINE" ARE SHADED.

FOR COOKWARE, NAMELY, METAL AND CERAMIC POTS AND PANS, NAMELY, CAST IRON PANS, SKILLETTS, ALUMINUM POTS AND PANS, SAUTE PANS, METAL BASE POTS AND PANS, CERAMIC POTS AND PANS, FRYING PANS, AND STAINLESS STEEL POTS AND PANS (U.S. CLS. 2, 13, 23, 29, 30, 33, 40 AND 50).

SALLY SHIH, EXAMINING ATTORNEY

SN 85-341,641. KLEAN KANTEEN, INC., CHICO, CA. FILED 6-8-2011.

KLEAN KANISTER

THE MARK CONSISTS OF STANDARD CHARACTERS WITHOUT CLAIM TO ANY PARTICULAR FONT, STYLE, SIZE, OR COLOR.

NO CLAIM IS MADE TO THE EXCLUSIVE RIGHT TO USE "KANISTER", APART FROM THE MARK AS SHOWN.

FOR REUSABLE CONTAINERS MADE OF STAINLESS STEEL FOR FOOD ITEMS (U.S. CLS. 2, 13, 23, 29, 30, 33, 40 AND 50).

ARETHA SOMERVILLE, EXAMINING ATTORNEY

SN 85-362,044. RED CUP LIVING, LLC, PHOENIX, AZ. FILED 7-1-2011.

RED CUP LIVING

THE MARK CONSISTS OF STANDARD CHARACTERS WITHOUT CLAIM TO ANY PARTICULAR FONT, STYLE, SIZE, OR COLOR.

NO CLAIM IS MADE TO THE EXCLUSIVE RIGHT TO USE "RED CUP", APART FROM THE MARK AS SHOWN.

FOR DINNERWARE, NAMELY, REUSABLE PLASTIC CUPS; PITCHERS; DINNERWARE; PORTABLE ICE CHEST FOR FOOD AND BEVERAGES; PORTABLE BEVERAGE COOLERS; GARBAGE CANS; KITCHEN GADGETS, NAMELY, BOTTLE OPENERS (U.S. CLS. 2, 13, 23, 29, 30, 33, 40 AND 50).

MARK SPARACINO, EXAMINING ATTORNEY

CLASS 21—(Continued).

SN 85-366,303. BELL, JAMES, PRESCOTT, MI. AND BELL, NAOMI, PRESCOTT, MI. FILED 7-8-2011.

Pot-Wear

THE MARK CONSISTS OF STANDARD CHARACTERS WITHOUT CLAIM TO ANY PARTICULAR FONT, STYLE, SIZE, OR COLOR.

FOR FLOWER-POT COVERS NOT OF PAPER (U.S. CLS. 2, 13, 23, 29, 30, 33, 40 AND 50).

DORITT L. CARROLL, EXAMINING ATTORNEY

SN 85-370,537. PLAYBOY ENTERPRISES INTERNATIONAL, INC., CHICAGO, IL. FILED 7-13-2011.

PLAYBOY

THE MARK CONSISTS OF STANDARD CHARACTERS WITHOUT CLAIM TO ANY PARTICULAR FONT, STYLE, SIZE, OR COLOR.

OWNER OF U.S. REG. NOS. 2,469,441, 3,406,607 AND OTHERS.

FOR BEVERAGE STIRRERS, BOTTLE OPENERS, CORK SCREWS, FLASK, MUGS, REUSABLE STAINLESS STEEL WATER BOTTLES SOLD EMPTY, PITCHERS (U.S. CLS. 2, 13, 23, 29, 30, 33, 40 AND 50).

MARTHA FROMM, EXAMINING ATTORNEY

CLASS 21—(Continued).

SN 85-383,010. GLORIOUS GARDENS LLC, BUFFALO GROVE, IL. FILED 7-28-2011.



NO CLAIM IS MADE TO THE EXCLUSIVE RIGHT TO USE "GARDENS", APART FROM THE MARK AS SHOWN. THE MARK CONSISTS OF THE STYLIZED LETTERING "GLORIOUS GARDENS" CURVING OVER THE IMAGE OF A POT SPILLING OUT SOIL. TO THE LEFT IS A SPADE SHOVEL AND PAIR OF GLOVES, ABOVE THE POT IS A BUNCH OF FLOWERS, AND ASSORTED FRUIT.

FOR PLANTERS FOR FLOWERS AND PLANTS, FLOWERPOTS; GARDENING GLOVES; WATERING CANS; NATURAL AND SYNTHETIC FIBER COCO LINERS FITTED FOR PLANT BOXES, PLANT POTS, AND PLANT BASKETS (U.S. CLS. 2, 13, 23, 29, 30, 33, 40 AND 50).

FIRST USE 6-15-2011; IN COMMERCE 6-15-2011.
SUNG IN, EXAMINING ATTORNEY

SN 85-389,069. MUCHA, LOIC, 11 NORTH VIEW STREET, HONG KONG, FILED 8-4-2011.

IKT

THE MARK CONSISTS OF STANDARD CHARACTERS WITHOUT CLAIM TO ANY PARTICULAR FONT, STYLE, SIZE, OR COLOR.

FOR ELECTRONIC CIRCUITS SOLD AS AN INTEGRAL COMPONENT OF KITCHEN TOOLS, GADGETS, UTENSILS AND ACCESSORIES, NAMELY, MIXING BOWLS, CUTTING BOARDS, TURNERS, LADLES, SPATULAS, COOKING BRUSHES FOR SAUCES, WHISKS, CHEESE GRATERS, ICE CREAM SCOOPS, COCKTAIL SHAKERS, SAUCE SHAKERS, ROLLING PINS, SILICONE MATS FOR USE IN BAKING, SILICONE OR STEEL BAKEWARE, HOUSEHOLD FOOD CONTAINERS, NON-ELECTRIC FOOD MIXERS, THE CIRCUITS INCLUDING ONE OR MORE SENSORS TO DETECT DIFFERENT TYPES OF INFORMATION FROM THE FOOD SURROUNDING OR IN CONTACT WITH THE SENSOR; SENSORS SEND INFORMATION TO WIRELESS AND WIRED DEVICES FOR ANALYSIS, NAMELY, TEMPERATURE, WEIGHT, VISCOSITY, COLOR, ODOR, CALORIES OR DIMENSIONS; THE SENSORS CAN ALSO READ PACKAGING BARCODES AND FOOD LABELS (U.S. CLS. 2, 13, 23, 29, 30, 33, 40 AND 50).

JOHN GARTNER, EXAMINING ATTORNEY

CLASS 21—(Continued).

SN 85-395,287. SMARTCUP, INC., AUBURN, CA. FILED 8-11-2011.



THE COLOR(S) MOCHA BROWN AND WHITE IS/ARE CLAIMED AS A FEATURE OF THE MARK.

THE MARK CONSISTS OF A STYLIZED MOCHA BROWN CUP WITH A WHITE "X" ON IT. THE CUP CONTAINS A FIGURATIVE FRENCH PRESS WITH THE PORTION OF THE FRENCH PRESS INSIDE THE CUP DEPICTED IN WHITE AND THE PORTION OF THE FRENCH PRESS ATOP THE CUP DEPICTED IN MOCHA BROWN. THE CUP IS FOLLOWED BY THE LETTERS "PRESS" IN MOCHA BROWN.

FOR DISPOSABLE BEVERAGE LID WITH AN INTEGRATED PRESS AND PLUNGER FOR PLACEMENT ON ANY CUP FOR THE PURPOSE OF INFUSING BEVERAGES (U.S. CLS. 2, 13, 23, 29, 30, 33, 40 AND 50).

FIRST USE 9-1-2009; IN COMMERCE 2-1-2010.
KATHERINE STOIDES, EXAMINING ATTORNEY

SN 85-408,993. ST. LOUIS GLASS COMPANY, HUNTLEIGH, MO. FILED S.R. 8-27-2011; AM. P.R. 1-11-2012.



THE COLOR(S) GREEN IS/ARE CLAIMED AS A FEATURE OF THE MARK.

THE MARK CONSISTS OF THE WORDING "VICTORY HAS IT'S REWARDS!" IN THE COLOR GREEN.

FOR FOOD PRESERVING JARS OF GLASS; GLASS JARS; GLASS STORAGE JARS; JARS FOR JAMS AND JELLIES OF GLASS (U.S. CLS. 2, 13, 23, 29, 30, 33, 40 AND 50).

TRACY CROSS, EXAMINING ATTORNEY

CLASS 21—(Continued).

SN 85-420,569. SMALDONE, JAMES M, RAHWAY, NJ. FILED 9-12-2011.

SMARTGRIP

THE MARK CONSISTS OF STANDARD CHARACTERS WITHOUT CLAIM TO ANY PARTICULAR FONT, STYLE, SIZE, OR COLOR.

FOR BASINS; BEER MUGS; BIODEGRADABLE PAPER PULP-BASED PLATES, BOWLS AND CUPS; BOWLS; BOWLS MADE OF PRECIOUS METAL; BREAD BINS; CERAMIC SCULPTURES, VASES, VESSELS, BOWLS, PLATES AND POTS; COFFEE CUPS, TEA CUPS AND MUGS; COFFEE MUGS; COMPOSTABLE AND BIODEGRADABLE PLATES, BOWLS, CUPS AND TRAYS; CONTAINERS FOR HOUSEHOLD USE FOR ENVELOPING AND PACKAGING DOMESTIC WASTE, INCLUDING DIAPERS AND NAPPIES, FOR STORAGE AND DISPOSAL, NAMELY, SANITARY WASTE DISPOSAL UNITS COMPRISING TUBS OR BINS WITH OR WITHOUT REELS OR CASSETTES CONTAINING WRAPPING MATERIALS FOR ENVELOPING WASTE; CROCKERY, NAMELY, POTS, DISHES, DRINKING CUPS AND SAUCERS, BOWLS, SERVING BOWLS AND TRAYS; CUPS AND MUGS; DISPOSABLE DINNERWARE, NAMELY, BOWLS; DUST BINS; EARTHENWARE BASINS; EARTHENWARE MUGS; FINGER BOWLS; FLOWER BOWLS; FLOWER BOWLS OF PRECIOUS METAL; FLOWER VASES AND BOWLS; FLOWER VASES AND BOWLS OF PRECIOUS METAL; FRUIT BOWLS; FRUIT BOWLS OF GLASS; GARBAGE CANS; GARBAGE PAILS; GENERAL PURPOSE STORAGE BINS FOR HOUSEHOLD USE; GLASS BOWLS; GLASS BOWLS FOR LIVE GOLDFISH; GLASS MUGS; HAIR TINTING BOWLS; HAND BASINS; HAND WASH BASINS; JAPANESE RICE BOWLS (CHAWAN); JAPANESE RICE BOWLS NOT OF PRECIOUS METAL (CHAWAN); JAPANESE RICE BOWLS OF PRECIOUS METAL (CHAWAN); JAPANESE STYLE SOUP SERVING BOWLS (WAN); LAUNDRY BINS FOR DOMESTIC OR HOUSEHOLD USE; MIXING BOWLS; MUG TREES; MUGS; MUGS, NOT OF PRECIOUS METAL; NON-METAL RECYCLING BINS FOR HOUSEHOLD USE; PEPPER POTS, SUGAR BOWLS AND SALT SHAKERS; PET FEEDING AND DRINKING BOWLS; PORCELAIN MUGS; RACKS AND STANDS FOR ELEVATING PET FEEDING BOWLS AND DISHES; RECYCLING BINS WITH BUILT-IN ELECTRONIC DISPLAY SCREENS FOR HOUSEHOLD USE; REFUSE BINS; REFUSE BINS WITH BUILT-IN ELECTRONIC DISPLAY SCREENS FOR HOUSEHOLD USE; REUSABLE SELF-SEALING LIDS FOR HOUSEHOLD USE FOR BOWLS, CUPS, CONTAINERS AND THE STORAGE OF FOOD; RINSING BOWLS; SALAD BOWLS; SALAD BOWLS; SERVING BOWLS (HACHI); SHALLOW BOWLS; SOAP DISPENSERS; SUGAR BOWLS; SUGAR BOWLS OF PRECIOUS METAL; WASH BASINS (U.S. CLS. 2, 13, 23, 29, 30, 33, 40 AND 50).

JESSICA FATHY, EXAMINING ATTORNEY

SN 85-424,874. LIBBEY GLASS INC., TOLEDO, OH. FILED 9-16-2011.

PUEBLA

THE MARK CONSISTS OF STANDARD CHARACTERS WITHOUT CLAIM TO ANY PARTICULAR FONT, STYLE, SIZE, OR COLOR.

FOR BEVERAGE GLASSWARE (U.S. CLS. 2, 13, 23, 29, 30, 33, 40 AND 50).

CURTIS FRENCH, EXAMINING ATTORNEY

CLASS 21—(Continued).

SN 85-426,390. MICHAEL HOTTINGER, GREENDALE, WI. FILED 9-19-2011.



NO CLAIM IS MADE TO THE EXCLUSIVE RIGHT TO USE "POT LIFTS", APART FROM THE MARK AS SHOWN.

THE MARK CONSISTS OF THE STYLIZED WORDS "POT-LIFTS" WITH A DESIGN OF A POT WITH LEAVES AND WITH FEET BELOW THE LETTER "O" IN THE WORD "POT".

FOR CERAMIC SCULPTURES, VASES, VESSELS, BOWLS, PLATES AND POTS; FLOWER POT HOLDERS; FLOWER POTS; PLANTERS FOR FLOWERS AND PLANTS; POT STANDS; POTS; RAISED GARDEN PLANTERS; SAUCERS FOR FLOWER POTS (U.S. CLS. 2, 13, 23, 29, 30, 33, 40 AND 50).

FIRST USE 6-1-2011; IN COMMERCE 9-15-2011.
B. PARADEWELAI, EXAMINING ATTORNEY

SN 85-427,739. CHECKWATER LLC, DBA CHECKWATER HYDRATION TECHNOLOGY, CAMPBELL, CA. FILED 9-21-2011.

QuickLink

THE MARK CONSISTS OF STANDARD CHARACTERS WITHOUT CLAIM TO ANY PARTICULAR FONT, STYLE, SIZE, OR COLOR.

FOR NON-METAL TUBE COUPLING CONSISTING OF A VALVED MALE COUPLING AND A VALVED FEMALE COUPLING, FOR CONNECTING AND DISCONNECTING DELIVERY TUBING THAT CONDUCTS LIQUID TO THE MOUTH OF AN INDIVIDUAL AS A COMPONENT PART OF A PORTABLE BEVERAGE DISPENSER FOR PROVIDING LIQUID TO THE MOUTH OF AN INDIVIDUAL INCLUDING A LIQUID CONTAINER, A LIQUID DELIVERY TUBE CONNECTED TO THE CONTAINER AND A MOUTHPIECE CONNECTED TO THE LIQUID DELIVERY TUBE FOR POSITIONING IN A USER'S MOUTH; HYDRATION SYSTEMS COMPRISING NON-METAL TUBE COUPLINGS, DELIVERY TUBING, AND VALVED DISPENSERS FOR DISPENSING THE CONTENTS OF LIQUID CONTAINERS FOR CONSUMPTION BY INDIVIDUALS (U.S. CLS. 2, 13, 23, 29, 30, 33, 40 AND 50).

RAMONA ORTIGA, EXAMINING ATTORNEY

CLASS 21—(Continued).

SN 85-437,344. DENTSOLL INC, DBA DENTSOLL, NOR-CROSS, GA. FILED 10-2-2011.



NO CLAIM IS MADE TO THE EXCLUSIVE RIGHT TO USE "ADVANCED DENTAL CARE SOLUTION", APART FROM THE MARK AS SHOWN.

THE COLOR(S) RED, BLUE, ORANGE, YELLOW, AND BLACK IS/ARE CLAIMED AS A FEATURE OF THE MARK.

THE MARK CONSISTS OF THE STYLIZED WORDING "DENTSOLL" WITH EACH LETTER "L" APPEARING AS A DENTAL INSTRUMENT. AN INCOMPLETE CIRCLE COMPRISED OF MANY SMALL CIRCLES STARTS ABOVE THE "T" IN "DENTSOLL" AND ENDS AFTER "SOLL" IN "DENTSOLL". UNDERNEATH "DENTSOLL" IN THE MARK IS THE STYLIZED WORDING "ADVANCED DENTAL CARE SOLUTION". THE COLOR BLACK APPEARS IN THE WORDING "ADVANCED DENTAL CARE SOLUTION". THE COLOR BLUE APPEARS IN THE WORD "DENT", AND THE COLOR RED APPEARS IN "SOLL", EXCEPT FOR THE UPPER TIPS OF THE DENTAL INSTRUMENTS, WHICH ARE ONLY OUTLINED IN RED. THE CIRCLES MAKING UP THE LARGER INCOMPLETE CIRCLE BEGIN WITH SEVERAL IN BLUE OVER THE "T" IN "DENT" FOLLOWED BY SEVERAL THAT ARE RED AND BLUE COMBINED, FOLLOWED BY A COUPLE RED CIRCLES, FOLLOWED BY SEVERAL ORANGE CIRCLES AND ENDING WITH SEVERAL YELLOW CIRCLES NEXT TO THE LAST "L" IN "SOLL" IN THE MARK. THE WHITE IN THE DRAWING INCLUDING THE WHITE IN THE TIPS OF EACH LETTER "L" IN "SOLL", REPRESENTS TRANSPARENT AREAS ONLY AND IS NOT PART OF THE MARK.

FOR ORAL HYGIENE DEVICES, NAMELY, INTERDENTAL CLEANERS (U.S. CLS. 2, 13, 23, 29, 30, 33, 40 AND 50).

FIRST USE 7-1-2009; IN COMMERCE 7-1-2009.
COLLEEN KEARNEY, EXAMINING ATTORNEY

SN 85-442,769. TORRES JR., WILLIAM, LORAIN, OH. FILED 10-8-2011.



NO CLAIM IS MADE TO THE EXCLUSIVE RIGHT TO USE "CHIP GRIP", APART FROM THE MARK AS SHOWN.

THE MARK CONSISTS OF THE WORDING "CHIP GRIP" IN BLACK STYLIZED LETTERING, PRECEDED BY TWO BLACK, ABSTRACT, OPPOSING HANDS.

FOR HOUSEHOLD UTENSILS; NAMELY, KITCHEN TONGS; SERVING TONGS (U.S. CLS. 2, 13, 23, 29, 30, 33, 40 AND 50).

H. M. FISHER, EXAMINING ATTORNEY

CLASS 21—(Continued).

SN 85-443,639. JACQUELINE CAMBATA DESIGNS LLC, WHEATON, IL. FILED 10-10-2011.

Jacqueline Cambata Designs

THE MARK CONSISTS OF STANDARD CHARACTERS WITHOUT CLAIM TO ANY PARTICULAR FONT, STYLE, SIZE, OR COLOR.

NO CLAIM IS MADE TO THE EXCLUSIVE RIGHT TO USE "DESIGNS", APART FROM THE MARK AS SHOWN.

THE NAME "JACQUELINE CAMBATA" IDENTIFIES A LIVING INDIVIDUAL WHOSE CONSENT IS OF RECORD.

FOR DINNERWARE (U.S. CLS. 2, 13, 23, 29, 30, 33, 40 AND 50).

FIRST USE 5-5-2005; IN COMMERCE 5-5-2005.
WILLIAM P. SHANAHAN, EXAMINING ATTORNEY

SN 85-445,362. NO. 9 CHRISTOPHER LLC, NEW YORK, NY. FILED 10-12-2011.

NO 9 CHRISTOPHER

THE MARK CONSISTS OF STANDARD CHARACTERS WITHOUT CLAIM TO ANY PARTICULAR FONT, STYLE, SIZE, OR COLOR.

FOR HOUSEHOLD UTENSILS, NAMELY, GRATERS, SPATULAS, SIEVES, STRAINERS, TURNERS, KITCHEN TONGS, AND WHISKS; COOKWARE, NAMELY, POTS AND PANS; BAKEWARE; BEVERAGE GLASSWARE; CANDLE HOLDERS; SERVING TRAYS (U.S. CLS. 2, 13, 23, 29, 30, 33, 40 AND 50).

SALLY SHIH, EXAMINING ATTORNEY

SN 85-447,159. PRODUCT ARCHITECTS, INC., BOULDER, CO. FILED 10-13-2011.

Cenoté

THE MARK CONSISTS OF STANDARD CHARACTERS WITHOUT CLAIM TO ANY PARTICULAR FONT, STYLE, SIZE, OR COLOR.

FOR PLASTIC CONTAINERS FOR DOMESTIC USE FOR WATER AND OTHER DRINKS; PLASTIC WATER BOTTLES SOLD EMPTY; PLASTIC PERSONAL HYDRATION SYSTEM BLADDERS FOR HOLDING LIQUID SOLD EMPTY; PLASTIC THERMAL INSULATED CONTAINERS FOR BEVERAGES (U.S. CLS. 2, 13, 23, 29, 30, 33, 40 AND 50).

KRISTIN DAHLING, EXAMINING ATTORNEY

CLASS 21—(Continued).

SN 85-449,514. KELLY, MICHAEL, TROUP, TX. FILED 10-18-2011.

SDEES

THE MARK CONSISTS OF STANDARD CHARACTERS WITHOUT CLAIM TO ANY PARTICULAR FONT, STYLE, SIZE, OR COLOR.

FOR HOUSEHOLD CONTAINERS FOR FOODS (U.S. CLS. 2, 13, 23, 29, 30, 33, 40 AND 50).

CURTIS FRENCH, EXAMINING ATTORNEY

CLASS 21—(Continued).

SN 85-450,323. ELLEN GARDNER, NEW YORK, NY. FILED 10-18-2011.

TOO HOT PAPA

THE MARK CONSISTS OF STANDARD CHARACTERS WITHOUT CLAIM TO ANY PARTICULAR FONT, STYLE, SIZE, OR COLOR.

FOR FOOD AND BEVERAGE COOLING PACKS (U.S. CLS. 2, 13, 23, 29, 30, 33, 40 AND 50).

CARRIE GENOVESE, EXAMINING ATTORNEY

SN 85-449,951. FLEET WHOLESALE SUPPLY CO., INC., APPLETON, WI. FILED 10-18-2011.



OWNER OF U.S. REG. NOS. 3,706,836, 3,777,408 AND OTHERS.

THE MARK CONSISTS OF THE WORDS "FLEET" AND "FARM" WITH A STYLIZED REPRESENTATION OF THE LETTERS "FF" BACK-TO-BACK AND A HALF CIRCLE ABOVE THE LEFT LETTER "F" IN BETWEEN THE WORDS.

FOR PAILS (U.S. CLS. 2, 13, 23, 29, 30, 33, 40 AND 50).

FIRST USE 7-14-2008; IN COMMERCE 7-14-2008.

MARY ROSSMAN, EXAMINING ATTORNEY

SN 85-450,330. KIDAROO CREW, LLC, LEAGUE CITY, TX. FILED 10-18-2011.

KIDAROO CREW

THE MARK CONSISTS OF STANDARD CHARACTERS WITHOUT CLAIM TO ANY PARTICULAR FONT, STYLE, SIZE, OR COLOR.

FOR NON-PAPER AND NON-TEXTILE IDENTIFICATION LABELS FOR USE IN IDENTIFYING BEVERAGE CONTAINERS AS BELONGING TO SPECIFIC USERS (U.S. CLS. 2, 13, 23, 29, 30, 33, 40 AND 50).

WILLIAM JACKSON, EXAMINING ATTORNEY

SN 85-450,168. KIDAROO CREW, LLC, LEAGUE CITY, TX. FILED 10-18-2011.

SCRIBELS KOALALABELS

THE MARK CONSISTS OF STANDARD CHARACTERS WITHOUT CLAIM TO ANY PARTICULAR FONT, STYLE, SIZE, OR COLOR.

FOR NON-PAPER AND NON-TEXTILE IDENTIFICATION LABELS FOR USE IN IDENTIFYING BEVERAGE CONTAINERS AS BELONGING TO SPECIFIC USERS (U.S. CLS. 2, 13, 23, 29, 30, 33, 40 AND 50).

WILLIAM JACKSON, EXAMINING ATTORNEY

SN 85-453,694. PRODUCT ARCHITECTS, INC., BOULDER, CO. FILED 10-21-2011.

SERIOUSLY CLEAN

THE MARK CONSISTS OF STANDARD CHARACTERS WITHOUT CLAIM TO ANY PARTICULAR FONT, STYLE, SIZE, OR COLOR.

FOR PLASTIC CONTAINERS FOR DOMESTIC USE FOR WATER AND OTHER DRINKS; PLASTIC WATER BOTTLES SOLD EMPTY; PLASTIC PERSONAL HYDRATION SYSTEM BLADDERS FOR HOLDING LIQUID SOLD EMPTY; THERMAL INSULATED CONTAINERS FOR BEVERAGES (U.S. CLS. 2, 13, 23, 29, 30, 33, 40 AND 50).

KRISTIN DAHLING, EXAMINING ATTORNEY

CLASS 21—(Continued).

SN 85-453,703. KIDAROO CREW, LLC, LEAGUE CITY, TX.
FILED 10-21-2011.

SPORTAROOS

THE MARK CONSISTS OF STANDARD CHARACTERS WITHOUT CLAIM TO ANY PARTICULAR FONT, STYLE, SIZE, OR COLOR.

FOR NON-PAPER AND NON-TEXTILE IDENTIFICATION LABELS FOR USE IN IDENTIFYING BEVERAGE CONTAINERS AS BELONGING TO SPECIFIC USERS (U.S. CLS. 2, 13, 23, 29, 30, 33, 40 AND 50).

WILLIAM JACKSON, EXAMINING ATTORNEY

SN 85-453,916. BUG DEFEND LLC, WILMINGTON, DE.
FILED 10-22-2011.



THE MARK CONSISTS OF AN IMAGE OF CIRCLE WITH A BUG IN IT AND A SLASH THROUGH THE CIRCLE AND BUG WITH THE WORDING "BUGDEFEND" AND "WWW.BUGDEFEND.COM" UNDERNEATH; ALL BEING INSIDE A SHIELD.

FOR INSECT TRAPS, NAMELY, BEDBUG COLLECTING HOUSINGS THAT ATTRACT BEDBUGS (U.S. CLS. 2, 13, 23, 29, 30, 33, 40 AND 50).

CHRISIE B. KING, EXAMINING ATTORNEY

SN 85-463,910. DIXIE CONSUMER PRODUCTS LLC,
ATLANTA, GA. FILED 11-3-2011.

EASY TO HOLD. EASY TO LOVE.

THE MARK CONSISTS OF STANDARD CHARACTERS WITHOUT CLAIM TO ANY PARTICULAR FONT, STYLE, SIZE, OR COLOR.

FOR CUPS (U.S. CLS. 2, 13, 23, 29, 30, 33, 40 AND 50).
NANCY CLARKE, EXAMINING ATTORNEY

CLASS 21—(Continued).

SN 85-466,697. RADIUS CORPORATION, KUTZTOWN, PA.
FILED 11-8-2011.

ORIGINAL

THE MARK CONSISTS OF STANDARD CHARACTERS WITHOUT CLAIM TO ANY PARTICULAR FONT, STYLE, SIZE, OR COLOR.

SEC. 2(F).
FOR TOOTHBRUSHES (U.S. CLS. 2, 13, 23, 29, 30, 33, 40 AND 50).

FIRST USE 11-23-1983; IN COMMERCE 11-23-1983.
CURTIS FRENCH, EXAMINING ATTORNEY

SN 85-485,846. KIDAROO CREW, LLC, LEAGUE CITY, TX.
FILED 12-2-2011.

SNUGAROOS KOALALABELS

THE MARK CONSISTS OF STANDARD CHARACTERS WITHOUT CLAIM TO ANY PARTICULAR FONT, STYLE, SIZE, OR COLOR.

FOR NON-PAPER AND NON-TEXTILE IDENTIFICATION LABELS FOR USE IN IDENTIFYING BEVERAGE CONTAINERS AS BELONGING TO SPECIFIC USERS (U.S. CLS. 2, 13, 23, 29, 30, 33, 40 AND 50).

WILLIAM JACKSON, EXAMINING ATTORNEY

SN 85-489,782. KIDAROO CREW, LLC, LEAGUE CITY, TX.
FILED 12-7-2011.

SIPPY GRAB

THE MARK CONSISTS OF STANDARD CHARACTERS WITHOUT CLAIM TO ANY PARTICULAR FONT, STYLE, SIZE, OR COLOR.

NO CLAIM IS MADE TO THE EXCLUSIVE RIGHT TO USE "SIPPY", APART FROM THE MARK AS SHOWN.

FOR NON-PAPER AND NON-TEXTILE IDENTIFICATION LABELS FOR USE IN IDENTIFYING BEVERAGE CONTAINERS AS BELONGING TO SPECIFIC USERS (U.S. CLS. 2, 13, 23, 29, 30, 33, 40 AND 50).

WILLIAM JACKSON, EXAMINING ATTORNEY

CLASS 21—(Continued).

SN 85-491,441. PAUL MICHAELS, HOUSTON, TX. FILED 12-9-2011.

CONTRASHOT

THE MARK CONSISTS OF STANDARD CHARACTERS WITHOUT CLAIM TO ANY PARTICULAR FONT, STYLE, SIZE, OR COLOR.

FOR SHOT GLASSES (U.S. CLS. 2, 13, 23, 29, 30, 33, 40 AND 50).

AMY ALFIERI, EXAMINING ATTORNEY

CLASS 22—CORDAGE AND FIBERS

SN 85-377,121. D.C. HUMPHRYS CO., INC., PHILADELPHIA, PA. FILED 7-21-2011.

INCREDISEAL

THE MARK CONSISTS OF STANDARD CHARACTERS WITHOUT CLAIM TO ANY PARTICULAR FONT, STYLE, SIZE, OR COLOR.

FOR TEXTILE SCREENS FOR ATTACHMENT TO FENCES, BORDERS AND ENCLOSURES; TEXTILE TARPAULINS FOR COVERING AND PROTECTING PLAYING FIELDS FROM NATURAL ELEMENTS; TEXTILE WINDSCREENS AND TEXTILE TARPAULINS FOR USE IN PROTECTING AND SCREENING ATHLETIC PLAYING SURFACES AND EQUIPMENT; TEXTILE TARPAULINS FOR COVERING AND PROTECTING INDOOR ATHLETIC SURFACES (U.S. CLS. 1, 2, 7, 19, 22, 42 AND 50).

WENDY JUN, EXAMINING ATTORNEY

SN 85-424,730. HYDROFARM, INC, PETALUMA, CA. FILED 9-16-2011.

DIRT POT

THE MARK CONSISTS OF STANDARD CHARACTERS WITHOUT CLAIM TO ANY PARTICULAR FONT, STYLE, SIZE, OR COLOR.

FOR FLEXIBLE HORTICULTURAL SACK COMPOSED OF WOVEN SYNTHETIC OR NATURAL FIBERS OR PLASTIC MATERIAL FOR USE IN THE TRANSPORT AND GROWTH OF PLANTS (U.S. CLS. 1, 2, 7, 19, 22, 42 AND 50).

JENNIFER VASQUEZ, EXAMINING ATTORNEY

CLASS 23—YARNS AND THREADS

SN 85-436,328. ORCHARD YARN AND THREAD COMPANY, DBA LION BRAND YARN COMPANY, NEW YORK, NY. FILED 9-30-2011.



THE MARK CONSISTS OF TWO VERTICALLY-PLACED, PARALLEL, RECTANGULAR-SHAPED BANDS EACH OF WHICH CONTAINS HORIZONTAL, EVENLY-SPACED HASH MARKS RESEMBLING A RULER TYPE DESIGN WITH CALIBRATED LINES TO MEASURE DISTANCES, WHEREIN THE HORIZONTAL HASH MARKS ARE NUMBERED AND TOUCH THE INTERIOR SIDES OF THE OUTSIDE EDGE SIDES OF EACH BAND AND RUN DOWN THE ENTIRE LENGTH OF THE BANDS. THE DOTTED VERTICAL LINES AT THE TOP AND BOTTOM AND INTERIOR SIDES ARE NOT A PART OF THE MARK, SERVE ONLY TO SHOW THE POSITION OF THE MARK ON THE OUTER PERIMETER OF THE PRODUCT LABEL, AND ARE NOT CLAIMED AS FEATURES OF THE MARK.

FOR YARN (U.S. CL. 43).

RICHARD WHITE, EXAMINING ATTORNEY

SN 85-449,607. T & C IMPORTS, EAST DENNIS, MA. FILED 10-18-2011.

FROG TREE

THE MARK CONSISTS OF STANDARD CHARACTERS WITHOUT CLAIM TO ANY PARTICULAR FONT, STYLE, SIZE, OR COLOR.

OWNER OF U.S. REG. NO. 2,626,557.

FOR KNITTING YARN (U.S. CL. 43).

FIRST USE 3-0-2001; IN COMMERCE 3-0-2001.

EMILY CHUO, EXAMINING ATTORNEY

CLASS 24—FABRICS

SN 79-100,485. I.T.G.-GMBH GRAPHIC PRODUCTS, FED REP GERMANY, FILED 6-15-2011.

I.T.G.

THE MARK CONSISTS OF STANDARD CHARACTERS WITHOUT CLAIM TO ANY PARTICULAR FONT, STYLE, SIZE, OR COLOR.

PRIORITY DATE OF 2-2-2011 IS CLAIMED.
OWNER OF INTERNATIONAL REGISTRATION 1085302 DATED 6-15-2011, EXPIRES 6-15-2021.
FOR TEXTILE PRINTING BLANKETS, NAMELY, PRINTING BLANKETS MADE OF COTTON WITH RUBBER COATING FOR INTAGLIO AND OFFSET PRINTING PRESSES (U.S. CLS. 42 AND 50).
CHRISTINA SOBRAL, EXAMINING ATTORNEY

SN 85-344,020. TRIANGLE HOME FASHIONS L.L.C., DAYTON, NJ. FILED 6-12-2011.

STUDIO J

THE MARK CONSISTS OF STANDARD CHARACTERS WITHOUT CLAIM TO ANY PARTICULAR FONT, STYLE, SIZE, OR COLOR.

NO CLAIM IS MADE TO THE EXCLUSIVE RIGHT TO USE "STUDIO", APART FROM THE MARK AS SHOWN.

FOR BABY BLANKETS; BED AND TABLE LINEN; BED BLANKETS; BED COVERS; BED SKIRTS; BED SPREADS; BED THROWS; COMFORTERS; CURTAINS; DRAPERIES; DUVETS; PET BLANKETS; PILLOW CASES; QUILT COVERS; QUILTS; SHAMS; SHEET SETS; SPIRIT-FILLED QUILTS FOR PETS; TABLE LINEN OF TEXTILE; THROWS; TOWEL SETS; WALL HANGINGS OF TEXTILE (U.S. CLS. 42 AND 50).

FIRST USE 6-6-2011; IN COMMERCE 6-6-2011.
JULIE GUTTADAURO, EXAMINING ATTORNEY

SN 85-390,645. THE TRILLIUM COLLECTION, INC., NASHVILLE, TN. FILED 8-5-2011.

TURKISH-T

THE MARK CONSISTS OF STANDARD CHARACTERS WITHOUT CLAIM TO ANY PARTICULAR FONT, STYLE, SIZE, OR COLOR.

NO CLAIM IS MADE TO THE EXCLUSIVE RIGHT TO USE "TURKISH", APART FROM THE MARK AS SHOWN.

FOR TURKISH TOWELS (U.S. CLS. 42 AND 50).
FIRST USE 1-0-2011; IN COMMERCE 1-0-2011.
SHAILA SETTLES, EXAMINING ATTORNEY

CLASS 24—(Continued).

SN 85-396,351. CULP, INC., HIGH POINT, NC. FILED 8-12-2011.

LEATHER RICH

THE MARK CONSISTS OF STANDARD CHARACTERS WITHOUT CLAIM TO ANY PARTICULAR FONT, STYLE, SIZE, OR COLOR.

NO CLAIM IS MADE TO THE EXCLUSIVE RIGHT TO USE "LEATHER", APART FROM THE MARK AS SHOWN.
FOR COMPOSITE FABRIC MADE PRIMARILY FROM RECYCLED LEATHER (U.S. CLS. 42 AND 50).
MARK SPARACINO, EXAMINING ATTORNEY

SN 85-425,185. ALLIED HOME, LLC, VERNON, CA. FILED 9-16-2011.



NO CLAIM IS MADE TO THE EXCLUSIVE RIGHT TO USE "RECYCLED RENEWABLE SUSTAINABLE", APART FROM THE MARK AS SHOWN.

THE COLOR(S) LIGHT GREEN, DARK GREEN, AND WHITE IS/ARE CLAIMED AS A FEATURE OF THE MARK.
THE MARK CONSISTS OF THE WORD "GREENLIGHT", WITH "GREEN" IN DARK GREEN AND "LIGHT" IN WHITE; BELOW THESE WORDS IS A LIGHT BULB WITH DARK GREEN LEAVES INSIDE THE BULB, A WHITE INTERIOR, AND A DARK GREEN OUTLINE AROUND THE ENTIRE BULB; THE WORDS "RECYCLED. RENEWABLE. SUSTAINABLE" ARE DIRECTLY BELOW THE LIGHT BULB AND APPEAR IN DARK GREEN. A DARK GREEN DOT APPEARS IN BETWEEN "RECYCLED" AND "RENEWABLE" AND BETWEEN "RENEWABLE" AND "SUSTAINABLE". A LIGHT GREEN BACKGROUND SUPPORTS THE ENTIRE MARK.

FOR COMFORTERS; BED BLANKETS; LAP BLANKETS; TRAVELLING BLANKETS; THROWS; MATTRESS PADS (U.S. CLS. 42 AND 50).

JORDAN BAKER, EXAMINING ATTORNEY

CLASS 24—(Continued).

SN 85-428,227. BARSON, PHYLLIS, SILVER SPRING, MD. FILED 9-21-2011.

CLASS 24—(Continued).

SN 85-442,762. PRECISION FABRICS GROUP, INC., GREENSBORO, NC. FILED 10-8-2011.

BED SHIRT

DERMASENSE

THE MARK CONSISTS OF STANDARD CHARACTERS WITHOUT CLAIM TO ANY PARTICULAR FONT, STYLE, SIZE, OR COLOR.

NO CLAIM IS MADE TO THE EXCLUSIVE RIGHT TO USE "BED", APART FROM THE MARK AS SHOWN.

FOR FITTED BED SHEETS; BED SKIRTS; BED LINEN (U.S. CLS. 42 AND 50).

MARILYN IZZI, EXAMINING ATTORNEY

THE MARK CONSISTS OF STANDARD CHARACTERS WITHOUT CLAIM TO ANY PARTICULAR FONT, STYLE, SIZE, OR COLOR.

FOR FABRICS FOR MEDICAL GARMENTS, NAMELY, MEDICAL GOWNS, PATIENT PAJAMAS, LAB COATS, SCRUB PANTS, SCRUB TOPS, AND NURSE'S APPAREL, NAMELY, NURSE TOPS, NURSE PANTS, NURSE DRESSES, AND NURSE SKIRTS; FABRICS FOR BEDDING AND BED LINENS; BEDDING, NAMELY, BED PADS, BEDSPREADS, BED BLANKETS; PILLOW PROTECTORS, NAMELY, PILLOW COVERS (U.S. CLS. 42 AND 50).

NAKIA HENRY, EXAMINING ATTORNEY

SN 85-441,974. ALOK INTERNATIONAL INC., DALLAS, TX. FILED 10-7-2011.

SN 85-444,282. SHARADHA TERRY PRODUCTS LIMITED, COIMBATORE, INDIA, FILED 10-11-2011.



OXYGEN

NO CLAIM IS MADE TO THE EXCLUSIVE RIGHT TO USE "TOWEL", APART FROM THE MARK AS SHOWN.

THE MARK CONSISTS OF THE STYLIZED WORDING "DURA TOWEL" WHEREIN THE LETTER "D" IS WRITTEN INSIDE A RECTANGULAR BOX, ABOVE WHICH THE WORD "DURA" IS WRITTEN, AND BELOW WHICH THE WORD "TOWEL" IS WRITTEN.

FOR TOWELS MADE OF TEXTILE MATERIALS (U.S. CLS. 42 AND 50).

NICHOLAS ALTREE, EXAMINING ATTORNEY

THE MARK CONSISTS OF STANDARD CHARACTERS WITHOUT CLAIM TO ANY PARTICULAR FONT, STYLE, SIZE, OR COLOR.

FOR BED LINENS, BED SHEETS, PILLOWCASES, BED SHEET SETS, COMFORTERS, DUVET COVERS, PILLOW SHAMS, BED SKIRTS, BEDSPREADS, COVERLETS, QUILTS, THROWS AND PILLOW COVERS, HAIR TOWELS, SPORT TOWELS, GOLF TOWELS, FABRIC SHOWER CURTAINS, CLOTH NAPKINS FOR REMOVING MAKE-UP, KITCHEN TOWELS, PLACEMATS NOT OF PAPER, PLACEMATS OF TEXTILE MATERIAL, TABLE LINEN, NAMELY, PLACEMATS, TABLE CLOTHS NOT OF PAPER, OVEN MITTS, POT HOLDERS, FABRIC TABLE RUNNERS, TEXTILE NAPKINS, TEA TOWELS, CUSHION COVERS AND WINDOW CURTAINS, WITH ALL OF THE FOREGOING MADE OF COTTON; BED BLANKETS MADE OF COTTON; BATH LINENS AND WASH CLOTHS (U.S. CLS. 42 AND 50).

DAVID I, EXAMINING ATTORNEY

CLASS 24—(Continued).

SN 85-448,049. COUNTS OF BARCELONA LLC, DBA SWEETEEZ, MOORPARK, CA. FILED 10-14-2011.



THE MARK CONSISTS OF A FLYING DANCER IMAGE. FOR (BASED ON USE IN COMMERCE) FACE TOWELS; FACE TOWELS OF TEXTILES; HAND TOWELS; HAND TOWELS OF TEXTILE; HAND-TOWELS MADE OF TEXTILE FABRICS; TERRY TOWELS; TOWELS; TOWELS MADE OF TEXTILE MATERIALS (BASED ON INTENT TO USE) BATH TOWELS; BEACH TOWELS; CHILDREN'S TOWELS; COMPRESSED TOWELS; FOOTBALL TOWELS; GOLF TOWELS; HOODED TOWELS; HOUSEHOLD LINEN, INCLUDING FACE TOWELS; JAPANESE COTTON TOWELS (TENUGUI); KITCHEN TOWELS; LARGE BATH TOWELS; MOISTURE ABSORBENT MICROFIBER TEXTILE FABRICS FOR USE IN THE MANUFACTURE OF ATHLETIC APPAREL, NAMELY, SHIRTS, PANTS, SHORTS, JACKETS, BAGS, TOWELS AND ATHLETIC UNIFORMS; TOWEL SETS; TOWEL SHEET; TOWELS THAT MAY BE WORN AS A DRESS OR SIMILAR GARMENT; TURKISH TOWEL (U.S. CLS. 42 AND 50).

FIRST USE 6-1-2011; IN COMMERCE 6-1-2011.
CARYN GLASSER, EXAMINING ATTORNEY

SN 85-448,558. C.H. JOHNSON, INC., CLEMMONS, NC. FILED 10-17-2011.

IT'S ALL YOURS

THE MARK CONSISTS OF STANDARD CHARACTERS WITHOUT CLAIM TO ANY PARTICULAR FONT, STYLE, SIZE, OR COLOR.
FOR PILLOW CASES (U.S. CLS. 42 AND 50).
LUCY ARANT, EXAMINING ATTORNEY

CLASS 24—(Continued).

SN 85-449,659. ASAP SERVICES, INC., CINCINNATI, OH. FILED 10-18-2011.

adverflag

THE MARK CONSISTS OF STANDARD CHARACTERS WITHOUT CLAIM TO ANY PARTICULAR FONT, STYLE, SIZE, OR COLOR.

FOR BANNERS AND FLAGS OF TEXTILE (U.S. CLS. 42 AND 50).

FIRST USE 8-11-2011; IN COMMERCE 8-11-2011.
HANNO RITTNER, EXAMINING ATTORNEY

SN 85-452,682. TWENTIETH CENTURY FOX FILM CORPORATION, LOS ANGELES, CA. FILED 10-20-2011.

CON GARRA

THE MARK CONSISTS OF STANDARD CHARACTERS WITHOUT CLAIM TO ANY PARTICULAR FONT, STYLE, SIZE, OR COLOR.

THE ENGLISH TRANSLATION OF "CON GARRA" IN THE MARK IS "PUNCHY".

FOR BED SHEETS; PILLOWCASES, PILLOW SHAMS; BLANKETS, NAMELY, BED BLANKETS; BLANKET THROWS; COMFORTERS; BED SPREADS; BATH TOWELS; BEACH TOWELS; KITCHEN TOWELS; FACE TOWELS; HAND TOWELS; WASH CLOTHS; OVEN MITTS; BARBECUE MITTS; TABLECLOTHS NOT MADE OF PAPER; PLACEMATS NOT MADE OF PAPER; FABRIC NAPKINS; SHOWER CURTAINS (U.S. CLS. 42 AND 50).

JANICE L. MCMORROW, EXAMINING ATTORNEY

SN 85-458,113. VICTORIA CLASSICS LTD., NEW YORK, NY. FILED 10-27-2011.

TECHNIQUES

THE MARK CONSISTS OF STANDARD CHARACTERS WITHOUT CLAIM TO ANY PARTICULAR FONT, STYLE, SIZE, OR COLOR.

FOR BED SHEETS, BEDSPREADS, COMFORTERS, CURTAINS, FABRIC WINDOW TREATMENTS AND COVERS, NAMELY, CURTAINS AND DRAPERIES (U.S. CLS. 42 AND 50).

ERIN FALK, EXAMINING ATTORNEY

CLASS 24—(Continued).

SN 85-458,133. VICTORIA CLASSICS LTD., NEW YORK, NY.
FILED 10-27-2011.

HONEY AND CLOVER

THE MARK CONSISTS OF STANDARD CHARACTERS WITHOUT CLAIM TO ANY PARTICULAR FONT, STYLE, SIZE, OR COLOR.

FOR BED SHEETS, BEDSPREADS, COMFORTERS, CURTAINS, FABRIC WINDOW TREATMENTS AND COVERS, NAMELY, CURTAINS AND DRAPERIES (U.S. CLS. 42 AND 50).

ERIN FALK, EXAMINING ATTORNEY

CLASS 25—(Continued).

SN 77-032,947. ARS NOVA PGM, LLC, NEW YORK, NY.
FILED 10-31-2006.

BLACK DYNAMITE**CLASS 25—CLOTHING**

SN 76-709,285. PURYEAR, RHONDA, CHURCH ROAD, VA.
FILED 10-4-2011.



THE MARK CONSISTS OF THE STYLIZED WORDING "I.T.I.T. IN TROPICAL ISLAND TRAINING" WITH A DESIGN OF THE SUN FORMING THE DOT OVER THE SECOND "I". ALL APPEARING INSIDE A RECTANGULAR BOX DESIGN.

FOR CLOTHING, NAMELY, COATS, PANTS, SHIRTS, JACKETS, HATS AND SWEATERS (U.S. CLS. 22 AND 39).

NATALIE POLZER, EXAMINING ATTORNEY

THE MARK CONSISTS OF STANDARD CHARACTERS WITHOUT CLAIM TO ANY PARTICULAR FONT, STYLE, SIZE, OR COLOR.

FOR FOOTWEAR, HEADWEAR, AND CLOTHING, NAMELY, T-SHIRTS, POLO SHIRTS, SWEATSHIRTS, SWEATPANTS, SLACKS, SHORTS AND JACKETS (U.S. CLS. 22 AND 39).

MATTHEW PAPPAS, EXAMINING ATTORNEY

SN 77-696,626. TESTA, KATHLEEN CECILIA, LIBERTYVILLE, IL. FILED 3-23-2009.

Babies Save the World

SN 76-709,553. ELARDO, ROBERT, CAPE CORAL, FL.
FILED 10-27-2011.

BOOROO

THE MARK CONSISTS OF STANDARD CHARACTERS WITHOUT CLAIM TO ANY PARTICULAR FONT, STYLE, SIZE, OR COLOR.

FOR FOOTWEAR FOR MEN AND WOMEN (U.S. CLS. 22 AND 39).

JAY FLOWERS, EXAMINING ATTORNEY

THE MARK CONSISTS OF STANDARD CHARACTERS WITHOUT CLAIM TO ANY PARTICULAR FONT, STYLE, SIZE, OR COLOR.

FOR INFANT WEAR (U.S. CLS. 22 AND 39).

RUDY R. SINGLETON, EXAMINING ATTORNEY

CLASS 25—(Continued).

SN 77-805,964. BURLINGTON INDUSTRIES LLC, GREENSBORO, NC. FILED 8-17-2009.



OWNER OF U.S. REG. NOS. 138,483, 2,147,243 AND 2,482,324.

NO CLAIM IS MADE TO THE EXCLUSIVE RIGHT TO USE "ORIGINAL", APART FROM THE MARK AS SHOWN.

THE MARK CONSISTS OF A DESIGN OF A CIRCULAR CLIP OR PIN WITH THE WORDS "BURLINGTON" AND "THE ORIGINAL" PRINTED AROUND THE OUTER EDGE AND A SOLID DIAMOND DESIGN BISECTED BY TWO OPPOSING BROKEN LINES APPEARING IN THE CENTER. THE BACKGROUND DESIGN, A SOCK DESIGN REPRESENTED BY A BROKEN LINE, IS NOT PART OF THE MARK. IT IS INTENDED TO SHOW THE PLACEMENT OF THE MARK ON THE GOODS.

FOR CLOTHING, NAMELY, UNIFORMS, COATS, JACKETS, T-SHIRTS, SHIRTS, BLOUSES, VESTS, PANTS, SLACKS, JEANS, SHORTS, SKIRTS, JUMPERS, OVERALLS, JERSEYS, SWEATERS, PULLOVERS, SWEATPANTS, SWEATSHIRTS, TRAINING SUITS, RUNNING SUITS, WARM-UP SUITS, SWIMWEAR, GLOVES, MITTENS, UNDERWEAR, BOXER SHORTS, SLEEPWEAR, ROBES, SCARVES, BANDANAS, HEADWEAR, HATS, CAPS, HEADBANDS, WRISTBANDS, NECKWEAR; HOSIERY AND SOCKS (U.S. CLS. 22 AND 39).

TIMOTHY FINNEGAN, EXAMINING ATTORNEY

SN 77-854,248. ALEXANDER YAMAGUCHI, DBA BLACK CRANE, LOS ANGELES, CA. AND MOMOKO YAMAGUCHI, DBA BLACK CRANE, LOS ANGELES, CA. FILED 10-21-2009.

BLACK CRANE



THE MARK CONSISTS OF THE WORD "BLACK CRANE" IN UPPERCASE STYLIZED FONT CENTERED ABOVE A DRAWING OF A SILHOUETTE OF TWO CRANES, FACING OUTWARD, BACK TO BACK.

FOR BELTS; DRESSES; HATS; HOODED SWEAT SHIRTS; JACKETS; PANTS; SHIRTS; SHOES; SHORTS; SKIRTS; SWEAT SHIRTS; SWEATERS; TANK TOPS; TOPS (U.S. CLS. 22 AND 39).

FIRST USE 10-1-2009; IN COMMERCE 10-1-2009. CHRISTINE MARTIN, EXAMINING ATTORNEY

CLASS 25—(Continued).

SN 78-092,797. QUIKSILVER, INC., HUNTINGTON BEACH, CA. FILED 11-12-2001.

TEENIE WAHINE

FOR CLOTHING, HEADWEAR AND FOOTWEAR, NAMELY, SHIRTS, T-SHIRTS, DRESSES, SKIRTS, PJAMAS, SWIM SUITS, SWEATSHIRTS, SWEAT PANTS, TANK TOPS, SHORTS, PANTS, JACKETS, SWEATERS, SOCKS, BELTS, WETSUITS, SKI WEAR, SNOWBOARD CLOTHING, NAMELY, SNOW PANTS, POWDER PANTS, JACKETS, SNOW BIBS, GLOVES, THERMAL UNDERWEAR, SHOES, ATHLETIC SHOES, SANDALS, SLIPERS, BOOTS, BEACH FOOTWEAR, HATS, CAPS AND VISORS (U.S. CLS. 22 AND 39).

FIRST USE 6-6-1997; IN COMMERCE 6-6-1997.

MARY CRAWFORD, EXAMINING ATTORNEY

SN 79-094,549. TIMEX FASHION DESIGNS LIMITED, LONDON W2 1LA, UNITED KINGDOM, FILED 2-8-2011.



PRIORITY DATE OF 1-5-2011 IS CLAIMED. OWNER OF INTERNATIONAL REGISTRATION 1069625 DATED 2-8-2011, EXPIRES 2-8-2021.

THE COLOR(S) BLACK AND GOLD IS/ARE CLAIMED AS A FEATURE OF THE MARK.

THE MARK CONSISTS OF A BLACK RECTANGLE WITH THE WORD "AVIRATE" IN GOLD ALONG THE BOTTOM WITH A GOLD LINE ABOVE IT. THERE IS ALSO A STYLIZED LETTER "A" FLOATING ABOVE A STYLIZED LETTER "T" BOTH IN GOLD AT THE TOP OF THE RECTANGLE.

FOR LADIES CLOTHES, NAMELY, SHIRTS, BLOUSES, TROUSERS, TOPS, T-SHIRTS, SHORTS, VESTS, CARDIGANS, JUMPERS, JACKETS, COATS, SOCKS, TIGHTS, HATS, SCARVES, GLOVES, GOWNS, DRESSES, LINGERIE, UNDERWEAR, SHOES, CLOTHING BELTS, AND JEANS (U.S. CLS. 22 AND 39).

PAUL MORENO, EXAMINING ATTORNEY

CLASS 25—(Continued).

SN 79-096,885. FGF INDUSTRY S.P.A., ITALY, FILED 3-8-2011.



OWNER OF INTERNATIONAL REGISTRATION 1075745 DATED 3-8-2011, EXPIRES 3-8-2021.

NO CLAIM IS MADE TO THE EXCLUSIVE RIGHT TO USE "LEATHER CLOTHING CO", APART FROM THE MARK AS SHOWN.

THE MARK CONSISTS OF THE DESIGN OF TWO CARICATURE PILOTS IN THE FOREGROUND. IN THE BACKGROUND, A STYLIZED PROPELLER PLANE APPEARS IN THE SKY WITH A BUILDING, TRANSMITTING TOWER AND A CLOUD. BENEATH THE DESIGN ELEMENT, THE WORDING "AERO LEATHER CLOTHING CO" APPEARS IN STYLIZED FONT.

FOR CLOTHING, NAMELY, RAINCOATS, SHIRTS, JUMPERS, PULLOVERS, DRESSES, SHORTS, TROUSERS, SUITS, SCARVES, SKIRTS; AND CLOTHING MADE OF LEATHER, NAMELY, FOOTWEAR, GLOVES, BELTS, JACKETS, COATS, TRENCH COATS, AND HEADWEAR (U.S. CLS. 22 AND 39).

MARILYN IZZI, EXAMINING ATTORNEY

CLASS 25—(Continued).

SN 79-097,819. ANDREAS SPREITER, SWITZERLAND, FILED 2-15-2011.

Nurévo

THE MARK CONSISTS OF STANDARD CHARACTERS WITHOUT CLAIM TO ANY PARTICULAR FONT, STYLE, SIZE, OR COLOR.

OWNER OF INTERNATIONAL REGISTRATION 1078415 DATED 2-15-2011, EXPIRES 2-15-2021.

THE WORDING "NURÉVO" HAS NO MEANING IN A FOREIGN LANGUAGE.

FOR CLOTHING, NAMELY, PANTS; MONEY BELTS; BELTS; SWEATERS; SHIRTS; TROUSERS; PULLOVERS; TEE-SHIRTS; JACKETS (U.S. CLS. 22 AND 39).

LINDA MICKLEBURGH, EXAMINING ATTORNEY

SN 79-099,215. GIOVANNA SBIROLI CONFEZIONI S.R.L. IN SIGLA GIOVANNA SBIROLI S.R.L., ITALY, FILED 3-15-2011.

SN 79-096,912. NATURANA CARL DÖLKER GMBH & CO KG, FED REP GERMANY, FILED 4-18-2011.



OWNER OF INTERNATIONAL REGISTRATION 1075830 DATED 4-18-2011, EXPIRES 4-18-2021.

THE COLOR(S) BLACK IS/ARE CLAIMED AS A FEATURE OF THE MARK.

THE MARK CONSISTS OF THE LETTER "N" IN BLACK INSIDE A BLACK OVAL DESIGN.

FOR CLOTHING, NAMELY, UNDERCLOTHES, BEACHWEAR, SWIMWEAR, NIGHTWEAR, AND LEISUREWEAR, NAMELY, SHIRTS, T-SHIRTS, SWEATERS, SHORTS, TROUSERS, PANTS, LEGGINGS, SKIRTS, DRESSING GOWNS, LEISURE SUITS (U.S. CLS. 22 AND 39).

WILLIAM BRECKENFELD, EXAMINING ATTORNEY

OWNER OF INTERNATIONAL REGISTRATION 0548798 DATED 2-6-1990, EXPIRES 2-6-2020.

THE NAME(S), PORTRAIT(S), AND/OR SIGNATURE(S) SHOWN IN THE MARK IDENTIFIES "GIOVANNA SBIROLI", WHOSE CONSENT(S) TO REGISTER IS MADE OF RECORD.

THE MARK CONSISTS OF THE STYLIZED WORDING "GIOVANNA SBIROLI".

FOR WEDDING GOWN, BRIDESMAID DRESSES, WEDDING DRESSES, EVENING DRESSES, DRESSES, DRESSING GOWNS, SHIRTS, BLOUSES, CHEMISES, BODICES, BUSTIERS, PANTALOONS, SKIRTS, PETTI-COATS, SUITS, JACKETS, ASCOTS, DUST COATS, COATS, JERKINS, WAISTCOATS, BOLEROS, SHAWLS, STOLES, FUR STOLE, TIES, NECKTIES, BOW TIES, MEN'S FORMAL PLASTRON NECKWEAR, BELTS FOR CLOTHING, BRACES IN THE NATURE OF SUSPENDERS, GLOVES, CUFFS, TUXEDOS, CUMMERBUNDS, SASHES, PANTYHOSE, SUSPENDERS, ANKLETS IN THE NATURE OF SOCKS, BOAS, FOU-LARDS IN THE NATURE OF SCARVES, VEILS, NECKERCHIEFS, POCKET KERCHIEFS, SHOES, LOAFERS, SANDALS, HAT, TOP HAT (U.S. CLS. 22 AND 39).

TRACY FLETCHER, EXAMINING ATTORNEY

CLASS 25—(Continued).

SN 79-099,869. GAUDI' TRADE S.P.A., ITALY, FILED 6-6-2011.

G.J. ITALIA

THE MARK CONSISTS OF STANDARD CHARACTERS WITHOUT CLAIM TO ANY PARTICULAR FONT, STYLE, SIZE, OR COLOR.

OWNER OF INTERNATIONAL REGISTRATION 1083801 DATED 6-6-2011, EXPIRES 6-6-2021.

NO CLAIM IS MADE TO THE EXCLUSIVE RIGHT TO USE "ITALIA", APART FROM THE MARK AS SHOWN.

THE ENGLISH TRANSLATION OF "ITALIA" IN THE MARK IS ITALY.

FOR CLOTHING, NAMELY, COATS, MANTLES, RAINCOATS, OVERCOATS, WAISTCOATS, PARKAS, ANORAKS, BLOUSONS, DRESSES, DRESSES FOR WOMEN, SUITS, SKIRTS, JACKETS, SPORT JACKETS, BLAZERS, WIND-RESISTANT JACKETS, TROUSERS, SPORT TROUSERS, JEANS, PANTS, SHORTS, SHIRTS, T-SHIRTS, BLOUSES, JERSEYS, SWEATERS, CARDIGANS, PULLOVERS, STOCKINGS, SOCKS, UNDERWEAR, CORSETS, NIGHTGOWNS, PAJAMAS, BATHROBES, BATHING SUITS, SUN SUITS, SWEAT SUITS, TIES, NECKTIES, SCARVES, SHAWLS, FOU-LARDS, GLOVES, SASHES AND BELTS, BREECHES, VESTS, CAMISOLES; FOOTWEAR, NAMELY, CASUAL AND SPORTING SHOES, BOOTS, SLIPPERS AND SANDALS; HEADGEAR, NAMELY, CAPS AND HATS (U.S. CLS. 22 AND 39).

JOHN DWYER, EXAMINING ATTORNEY

SN 79-099,904. JOSEF SEIBEL SCHUHFABRIK GMBH, FED REP GERMANY, FILED 3-29-2011.

AIRPED

THE MARK CONSISTS OF STANDARD CHARACTERS WITHOUT CLAIM TO ANY PARTICULAR FONT, STYLE, SIZE, OR COLOR.

PRIORITY DATE OF 10-21-2010 IS CLAIMED.

OWNER OF INTERNATIONAL REGISTRATION 1083906 DATED 3-29-2011, EXPIRES 3-29-2021.

FOR CLOTHING, NAMELY, SHORTS, SHIRTS, TOPS, PANTS, BOTTOMS, BLOUSES, SKIRTS; FOOTWEAR, NAMELY, COMFORTABLE FOOTWEAR, SPORTS AND LEISURE FOOTWEAR, SPORTS AND LEISURE SHOES, WORK SHOES, SHOES AND SANDALS FOR MEN, FOOTWEAR FOR FOOT GYMNASTICS, WORK, LEISURE AND SPORTS, NAMELY, SANDALS AND CLOGS, WITH FOOT BEDS AND MOLDED SHOE INSERTS FOR NON-ORTHOPEDIC PURPOSES OR NON-ORTHOPEDIC SHOE INSERTS; SHOE INSERTS PRIMARILY FOR NON-ORTHOPEDIC PURPOSES IN NAMELY, FOOT PADS, INSERTS TO PROTECT THE PRESSURE-SENSITIVE POINTS OF THE FOOT, INSOLES, SHOE SOLES, FOOT BEDS AND SHAPED INNER SOLES IN THE NATURE OF SHAPED SOLES AND FOOT BEDS IN THE FORM OF SOLID PLASTIC INSERTS OR ANATOMICALLY SHAPED DEEP FOOT BEDS (U.S. CLS. 22 AND 39).

SUE LAWRENCE, EXAMINING ATTORNEY

CLASS 25—(Continued).

SN 79-100,032. MOALTO S.R.L., ITALY, FILED 4-21-2011.



BRIMARTS

OWNER OF INTERNATIONAL REGISTRATION 1084211 DATED 4-21-2011, EXPIRES 4-21-2021.

THE MARK CONSISTS OF FANCIED WORD "BRIMARTS" IN BOLD CAPITAL CHARACTERS ABOVE OF WHICH THE STYLIZED REPRESENTATION OF A SHIELD IS LOCATED.

THE WORDING "BRIMARTS" HAS NO MEANING IN A FOREIGN LANGUAGE.

FOR CLOTHING, NAMELY, MEN'S, WOMEN'S AND CHILDREN'S SOCKS, BEACHWEAR, BATHROBES, BELTS, BERETS, BLOUSES, BOOTS, BOTTOMS, BRAS, BRIEFS, CAMISOLES, CAPS, COATS, DENIMS, DRESSES, DRESS SUITS, DRESS SHIRTS, GLOVES, HATS, HOSIERY, INFANT WEAR, JEANS, JOGGING SUITS, COATS, LINGERIE, NIGHTWEAR, PAJAMAS, PANTSUITS, PONCHOS, RAIN COATS, RAINWEAR, ROBES, SCARVES, SHAWLS, SHIRTS, SHOES, SHORTS, SHORT-SLEEVED OR LONG-SLEEVED T-SHIRTS, SKI WEAR, SKIRTS, SKIRTS AND DRESSES, SLEEPWEAR, SLIPPERS, SUN VISORS, SWEAT BANDS, TIES, TOPS, UNDER GARMENTS, UNDERWEAR, VESTS, WIND-JACKETS, WRISTBANDS, JACKETS, CARDIGANS, TROUSERS, SUITS, UNDERPANTS, HALF-BOOTS, BEACH SHOES, SANDALS, INNER SOLES FOR SHOES AND BOOTS, SPORTS SHOES, BANDANAS, NECK-ERCHIEFS, MITTENS, TURBANS, SPORTS JACKETS, SWEAT PANTS, SWEAT SHIRTS, APRONS, CLOTH BIBS; FOOTWEAR (U.S. CLS. 22 AND 39).

TRACY FLETCHER, EXAMINING ATTORNEY

SN 79-102,846. ZANIER - SPORT GESELLSCHAFT M.B.H., INNSBRUCK, AUSTRIA, FILED 8-18-2011.

ZANIER

THE MARK CONSISTS OF STANDARD CHARACTERS WITHOUT CLAIM TO ANY PARTICULAR FONT, STYLE, SIZE, OR COLOR.

OWNER OF INTERNATIONAL REGISTRATION 0741155 DATED 8-11-2000, EXPIRES 8-11-2020.

FOR GLOVES (U.S. CLS. 22 AND 39).

ROBERT STRUCK, EXAMINING ATTORNEY

CLASS 25—(Continued).

SN 79-104,794. ZHEJIANG OUHAI; INTERNATIONAL TRADE CORPORATION, ZHEJIANG, CHINA, FILED 9-5-2011.

PICTOON

OWNER OF INTERNATIONAL REGISTRATION 1096167 DATED 9-5-2011, EXPIRES 9-5-2021.

THE MARK CONSISTS OF THE TERM "PICTOON" IN STYLIZED FONT.

FOR CLOTHING, NAMELY, SHIRTS, SWEATERS, DUST COATS, TROUSERS AND SPORTS JERSEYS; T-SHIRTS, IN PARTICULAR FOR BABIES, ADULTS, CHILDREN, WOMEN AND MEN; CLOTHING FOR BABIES, TODDLERS AND CHILDREN, TREATED WITH FIRE AND HEAT RETARDANTS, NAMELY, PAJAMAS JACKETS, SHIRTS, PANTS, JUMPERS; SHOES; RUNNING SHOES; SLIPPERS; SANDALS; BOOTS; HATS; LEATHER BELTS BEING CLOTHING (U.S. CLS. 22 AND 39).

STEVEN PEREZ, EXAMINING ATTORNEY

SN 79-106,328. DEBENHAMS RETAIL PLC, UNITED KINGDOM, FILED 6-15-2011.

RED HERRING

THE MARK CONSISTS OF STANDARD CHARACTERS WITHOUT CLAIM TO ANY PARTICULAR FONT, STYLE, SIZE, OR COLOR.

OWNER OF INTERNATIONAL REGISTRATION 0905776 DATED 9-1-2006, EXPIRES 9-1-2016.

FOR ARTICLES OF CLOTHING, NAMELY, PANTS, TROUSERS, SLACKS, JEANS, SWEATPANTS, SHIRTS, BLOUSES, T-SHIRTS, POLO SHIRTS, PULLOVERS, CARDIGANS, SWEATERS, SWEATSHIRTS, BLAZERS, JACKETS, WIND RESISTANT JACKETS, COATS, RAINCOATS, MEN'S SUITS, TIES, BOW TIES, DINNER JACKETS, FORMAL SUITS, UNDERWEAR, BOXER SHORTS, BRIEFS, PANTIES, SUSPENDERS, SWIMWEAR, BATHING SUITS, BEACHWEAR, BATHROBES, WOMEN'S SUITS, GOWNS, SKIRTS, DRESSES, NIGHTWEAR DRESSES, SCARVES, SHAWLS, JACKETS, SHORTS, BODY SUITS, BOOTS, NECKWEAR, GLOVES, HOSIERY, JUMPSUITS, LINGERIE, PAJAMAS, VESTS, RAINWEAR, SOCKS, WALKING AND MOUNTAIN CLIMBING WEAR, NAMELY, ONE-PIECE EXPEDITION SUITS, INSULATED UNDERWEAR, WATER PROOF INSULATED PULLOVERS AND PANTS, FOOTWEAR, NAMELY, BOOTS, SHOES, SLIPPERS, SANDALS, FLIP FLOPS, TRAINERS BEING SNEAKERS, SOCKS AND HOSIERY; HEADGEAR, NAMELY, HATS, CAPS, BERETS, HEADBANDS, EAR MUFFS; SCARVES; GLOVES; MITTENS; BELTS FOR CLOTHING (U.S. CLS. 22 AND 39).

JORDAN BAKER, EXAMINING ATTORNEY

CLASS 25—(Continued).

SN 85-007,793. PEREZ, NOE, GRAND FORKS, ND. FILED 4-6-2010.

Daehtop

THE MARK CONSISTS OF STANDARD CHARACTERS WITHOUT CLAIM TO ANY PARTICULAR FONT, STYLE, SIZE, OR COLOR.

THE WORD "DAEHTOP" HAS NO MEANING IN A FOREIGN LANGUAGE.

FOR BELTS; HATS; HOODED SWEAT SHIRTS; JACKETS; PANTS; SOCKS; SWEAT SHIRTS; T-SHIRTS; TANK TOPS (U.S. CLS. 22 AND 39).

EDWARD NELSON, EXAMINING ATTORNEY

SN 85-026,787. LMT GLOBAL LLC, ONTARIO, CA. FILED 4-29-2010.

MYTH NYC

THE MARK CONSISTS OF STANDARD CHARACTERS WITHOUT CLAIM TO ANY PARTICULAR FONT, STYLE, SIZE, OR COLOR.

NO CLAIM IS MADE TO THE EXCLUSIVE RIGHT TO USE "NYC", APART FROM THE MARK AS SHOWN.

FOR CLOTHING, NAMELY, SHIRTS, T-SHIRTS, UNDER SHIRTS, NIGHT SHIRTS, RUGBY SHIRTS, POLO SHIRTS, CARDIGANS, JERSEYS, UNIFORMS, PANTS, TROUSERS, SUITS, BLAZERS, DRESS SHIRTS, SLACKS, JEANS, DENIM JEANS, CULOTTES, CARGO PANTS, OVERALLS, COVERALLS, JUMPERS, JUMP SUITS, SHORTS, BOXER SHORTS, TOPS, CROP TOPS, TANK TOPS, HALTER TOPS, SWEAT SHIRTS, SWEAT SHORTS, SWEAT PANTS, WRAPS, WARM-UP SUITS, JOGGING SUITS, TRACK SUITS, PLAY SUITS, BLOUSES, SKIRTS, DRESSES, GOWNS, SWEATERS, VESTS, FLEECE VESTS, PULLOVERS, SNOW SUITS, PARKAS, CAPES, ANORAKS, PONCHOS, JACKETS, SPORTS JACKETS, REVERSIBLE JACKETS, FLEECE JACKETS, COATS, TURTLENECKS, CLOTH SKI BIBS, BEACHWEAR, TENNIS WEAR, SURF WEAR, SKI WEAR, LAYETTES, INFANT WEAR, INFANTS SLEEPERS, BOOTIES, BABY BIBS NOT OF PAPER, CLOTH DIAPERS, CAPS, SWIM CAPS, BERETS, BEANIES, HATS, VISORS, HEADBANDS, WRIST BANDS, SWEAT BANDS, HEADWEAR, EAR MUFFS, APRONS, SCARVES, BANDANAS, BELTS, SUSPENDERS, NECKWEAR, NECKERCHIEFS, ASCOTS, UNDERWEAR, THERMAL UNDERWEAR, LONG UNDERWEAR, BRIEFS, SWIM AND BATHING TRUNKS, BRAS, SPORTS BRAS, BRASSIERES, BUSTIERS, CORSETS, PANTIES, THONGS, GARTERS AND GARTER BELTS, TEDDIES, GIRDLES, FOUNDATION GARMENTS, LOUNGEWEAR, ROBES, SMOCKS, UNDERCLOTHES, PAJAMAS, SLEEPWEAR, NIGHTWEAR, NIGHT GOWNS, LINGERIE, CAMISOLES, NEGLIGEEES, CHEMISES, CHEMISETTES, SLIPS, SARONGS, LEG WARMERS, PANTYHOSE, BODY STOCKINGS, KNEE HIGHS, LEGGINGS, TIGHTS, LEOTARDS, BODY SUITS, UNITARDS, BODY SHAPERS, GLOVES, MITTENS, RAINWEAR, SNEAKERS, BOOTS, GALOSHES, SANDALS, FLIP-FLOPS, AND SLIPPERS; FOOTWEAR, SHOES, HOSIERY, SOCKS, AND SWIMWEAR; MEN'S FORMALWEAR, NAMELY, SUITS, BLAZERS, JACKETS, TROUSERS, DRESS SHIRTS, TIES, COATS, RAIN COATS AND TRENCH COAT (U.S. CLS. 22 AND 39).

BRIAN CALLAGHAN, EXAMINING ATTORNEY

CLASS 25—(Continued).

SN 85-055,599. SUSAN OF NEW YORK INC., LOS ANGELES, CA. FILED 6-5-2010.



THE COLOR(S) RED, DARK BROWN, BEIGE AND DARK GRAY IS/ARE CLAIMED AS A FEATURE OF THE MARK. THE MARK CONSISTS OF THE WORD "LOVE" IN DARK BROWN STYLIZED FONT, FOLLOWED BY A RED HEART WITH A BEIGE OUTLINE AND DARK GRAY SHADOWING AROUND THE LOWER LEFT AND RIGHT SIDES OF THE HEART, FOLLOWED BY THE WORD "TOKEN" IN DARK BROWN STYLIZED FONT.

FOR COATS FOR MEN AND WOMEN; DRESS SUITS; DRESSES; EVENING DRESSES; MEN'S AND WOMEN'S JACKETS, COATS, TROUSERS, VESTS; WOMEN'S CEREMONIAL DRESSES; WOMEN'S TOPS, NAMELY, CAMIS (U.S. CLS. 22 AND 39).

FIRST USE 1-1-2010; IN COMMERCE 4-1-2010.
TINA BROWN, EXAMINING ATTORNEY

CLASS 25—(Continued).

SN 85-123,424. ANDERSON, ERIC SCOTT, DBA MY HAPPY, BROOKLYN, CT. FILED 9-5-2010.

My Happy

THE MARK CONSISTS OF STANDARD CHARACTERS WITHOUT CLAIM TO ANY PARTICULAR FONT, STYLE, SIZE, OR COLOR.

FOR ATHLETIC APPAREL, NAMELY, SHIRTS, PANTS, JACKETS, HATS AND CAPS, ATHLETIC UNIFORMS; BUTTON DOWN SHIRTS; CHILDREN'S AND INFANT'S APPAREL, NAMELY, JUMPERS, OVERALL SLEEPWEAR, PAJAMAS, ROMPERS AND ONE-PIECE GARMENTS; GOLF SHIRTS; HATS; HATS FOR INFANTS, BABIES, TODDLERS AND CHILDREN; HOODED SWEAT SHIRTS; LONG-SLEEVED SHIRTS; SHIRTS; SHIRTS AND SHORT-SLEEVED SHIRTS; SLEEP SHIRTS; SPORT SHIRTS; SPORTS CAPS AND HATS; SWEAT SHIRTS; T-SHIRTS; TEE SHIRTS, NONE OF THE FOREGOING BEING, OR BEING SUITABLE FOR USE AS, CHEF OF COOK STAFF CLOTHING (U.S. CLS. 22 AND 39).

FIRST USE 8-12-2007; IN COMMERCE 6-1-2010.
JOHN DWYER, EXAMINING ATTORNEY

SN 85-130,328. BUMBELLS, LLC, ENGLEWOOD, CO. FILED 9-15-2010.



THE MARK CONSISTS OF THE WORDING "BUMBELLS THE KIDS DUMBBELLS" AND A BUMBLE BEE WITH HIS LEFT ARM FLEXING HOLDING A DUMBBELL, AND HIS RIGHT ARM TO HIS SIDE.

FOR A-SHIRTS; ADULT NOVELTY GAG CLOTHING ITEM, NAMELY, SOCKS; ANGLERS' SHOES; ANKLE SOCKS; ANKLETS; ANTI-PERSPIRANT SOCKS; APPAREL FOR DANCERS, NAMELY, TEE SHIRTS, SWEAT-SHIRTS, PANTS, LEGGINGS, SHORTS AND JACKETS; APRES-SKI SHOES; AQUA SHOES; ATHLETIC APPAREL, NAMELY, SHIRTS, PANTS, JACKETS, FOOTWEAR, HATS AND CAPS, ATHLETIC UNIFORMS; ATHLETIC SHOES; BALLET SHOES; BALLOON PANTS; BALLROOM DANCING SHOES; BASEBALL CAPS AND HATS; BASEBALL SHOES; BEACH SHOES; BERMUDA SHORTS; BIB SHORTS; BOARD SHORTS; BOAT SHOES; BODY SHIRTS; BOWLING SHOES; BOXER SHORTS; BOXING SHOES; BOXING SHORTS; BUTTON DOWN SHIRTS; BUTTON-FRONT ALOHA SHIRTS; CAMOUFLAGE PANTS; CAMOUFLAGE SHIRTS; CAMP SHIRTS; CANVAS SHOES; CAPRI PANTS; CARGO PANTS; CHEF'S HATS; CLEATS FOR ATTACHMENT TO SPORTS SHOES; CLIMBING SHOES; CLOTHING FOR ATHLETIC USE, NAMELY, PADDED PANTS; CLOTHING FOR ATHLETIC USE, NAMELY, PADDED SHIRTS; CLOTHING FOR ATHLETIC USE, NAMELY,

SN 85-084,081. NEVILLE, FRANK W, NEW BRAUNFELS, TX. FILED 7-14-2010.



NO CLAIM IS MADE TO THE EXCLUSIVE RIGHT TO USE "GEAR", APART FROM THE MARK AS SHOWN.

THE MARK CONSISTS OF THE PHRASE "DALLY GEAR" WITH A STYLIZED 6 POINT STAR FOLLOWING THE TERM "DALLY" IN THE MARK.

FOR ATHLETIC APPAREL, NAMELY, SHIRTS, PANTS, JACKETS, FOOTWEAR, HATS AND CAPS, ATHLETIC UNIFORMS; BASEBALL CAPS; BASEBALL CAPS AND HATS; TOBOGGAN HATS, PANTS AND CAPS (U.S. CLS. 22 AND 39).

FIRST USE 12-20-2009; IN COMMERCE 4-15-2010.
JACLYN KIDWELL WALKER, EXAMINING ATTORNEY

CLASS 25—(Continued).

PADDED SHORTS; CLOTHING SHIELDS, NAMELY, PADS APPLIED TO THE UNDERARMS OF SHIRTS, BLOUSES AND SWEATERS; COLLARED SHIRTS; CYCLING SHOES; DANCE SHOES; DECK-SHOES; DENIMS; DRESS PANTS; DRESS SHIRTS; DRIVERS; FISHING SHIRTS; FITTED SHOE OR BOOT COVERING TO PROTECT THE SHOES OR BOOT FROM WATER OR OTHER DAMAGE; FLEECE SHORTS; FOOTBALL SHOES; FUR HATS; GIFT PACKAGES SOLD AS A UNIT CONSISTING PRIMARILY OF A SWEATSHIRT AND ALSO INCLUDING A PHOTO FRAME, A COFFEE MUG, AND A TOTE BAG; GOLF PANTS, SHIRTS AND SKIRTS; GOLF SHIRTS; GOLF SHOES; GOLF SHORTS; GYM PANTS; GYM SHORTS; GYMNASIIC SHOES; HANDBALL SHOES; HAT BANDS; HATS; HATS FOR INFANTS, BABIES, TODDLERS AND CHILDREN; HEADGEAR, NAMELY, HATS; HEEL PIECES FOR SHOES; HOCKEY SHOES; HOODED SWEAT SHIRTS; HUNTING BOOT BAGS; HUNTING PANTS; HUNTING SHIRTS; INFANTS' SHOES AND BOOTS; INSOLES; JACKETS AND SOCKS; JAPANESE STYLE SOCKS (TABI COVERS); JAPANESE STYLE SOCKS (TABI); JEGGINGS, NAMELY, PANTS THAT ARE PARTIALLY JEANS AND PARTIALLY LEGGINGS; JOGGING PANTS; KNIT SHIRTS; LEATHER HATS; LEATHER PANTS; LEATHER SHIRTS; LEATHER SHOES; LEG SHIELDING DEVICE, ATTACHABLE TO AND DETACHABLE FROM A PERSON'S PANTS, COMPRISED OF PADDING TO SHIELD THE LEGS FROM FLYING DEBRIS WHEN MOWING WITH A STRING TRIMMER; LEISURE SHOES; LONG-SLEEVED SHIRTS; LOUNGE PANTS; MEN'S DRESS SOCKS; MEN'S SOCKS; MOISTURE-WICKING SPORTS PANTS; MOISTURE-WICKING SPORTS SHIRTS; MOUNTAINEERING SHOES; NIGHT SHIRTS; NON-DISPOSABLE CLOTH TRAINING PANTS; NURSE PANTS; OPEN-NECKED SHIRTS; OVER SHIRTS; PANTIES, SHORTS AND BRIEFS; PANTS; PAPER HATS FOR USE AS CLOTHING ITEMS; PAPER SHOES USED WHEN GOING THROUGH METAL DETECTORS TO KEEP FEET AND SOCKS CLEAN; PARTY HATS; PERSPIRATION ABSORBENT STRAP TO BE USED IN THE BILL OF A HAT; PETTI-PANTS; PIQUE SHIRTS; POLO SHIRTS; POLYMER CUSTOM CUSHIONED SHOE INSERTS FOR PRIMARILY NON-ORTHOPEDIC PURPOSES; PROTECTIVE METAL MEMBERS FOR SHOES AND BOOTS; RAIN HATS; RIDING SHOES; RUBBER SHOES; RUGBY SHIRTS; RUGBY SHOES; RUGBY SHORTS; RUNNING PADS THAT STRAP ONTO SHOES; RUNNING SHOES; SANDALS AND BEACH SHOES; SCIENTIFIC AND TECHNOLOGICAL APPAREL, NAMELY, SHIRTS, PANTS, JACKETS, FOOTWEAR, HATS AND CAPS, UNIFORMS; SEDGE HATS (SUGE-GASA); SHIRT FRONTS; SHIRT YOKES; SHIRTS; SHIRTS AND SHORT-SLEEVED SHIRTS; SHIRTS AND SLIPS; SHIRTS FOR INFANTS, BABIES, TODDLERS AND CHILDREN; SHIRTS FOR SUITS; SHOE COVERS FOR USE WHEN WEARING SHOES; SHOE DOWELS; SHOE INSERTS FOR PRIMARILY NON-ORTHOPEDIC PURPOSES; SHOE PEGS; SHOE SOLES; SHOE STRAPS; SHOES; SHOES SOLES FOR REPAIR; SHOES WITH HOOK AND PILE FASTENING TAPES; SHORT OVERCOAT FOR KIMONO (HAORI); SHORT PETTICOATS; SHORT SETS; SHORT TROUSERS; SHORT-SLEEVED OR LONG-SLEEVED T-SHIRTS; SHORT-SLEEVED SHIRTS; SHORTS; SKI AND SNOWBOARD SHOES AND PARTS THEREOF; SKI BOOT BAGS; SKI PANTS; SKIING SHOES; SLEEP PANTS; SLEEP SHIRTS; SLEEVES WORN SEPARATE AND APART FROM BLOUSES, SHIRTS AND OTHER TOPS; SLIDING SHORTS; SLIPPER SOCKS; SMALL HATS; SNOW PANTS; SNOWBOARD PANTS; SOCCER SHOES; SOCK SUSPENDERS; SOCKS; SOCKS AND STOCKINGS; SPORT SHIRTS; SPORTS CAPS AND HATS; SPORTS PANTS; SPORTS SHIRTS; SPORTS SHIRTS WITH SHORT SLEEVES; STRETCH PANTS; SWEAT PANTS; SWEAT SHIRTS; SWEAT SHORTS; T-SHIRTS; TAP PANTS; TAP SHOES; TEE SHIRTS; TENNIS SHOES; THERMAL SOCKS; TOBOGGAN HATS, PANTS AND CAPS; TONGUE OR PULLSTRAP FOR SHOES AND BOOTS; TRACK AND FIELD SHOES; TRACK PANTS; TRAINING SHOES; TRAVEL CLOTHING CONTAINED IN A PACKAGE COMPRISING REVERSIBLE JACKETS, PANTS, SKIRTS, TOPS AND A BELT OR SCARF; TRIATHLON CLOTHING, NAMELY, TRIATHLON TIGHTS, TRIATHLON SHORTS, TRIATHLON SINGLET, TRIATHLON SHIRTS, TRIATHLON SUITS; TURTLE NECK SHIRTS;

CLASS 25—(Continued).

UNDERWEAR, NAMELY, BOY SHORTS; VOLLEYBALL SHOES; WALKING SHORTS; WATER REPELLING LEATHER SHOES AND BOOTS; WATER SOCKS; WATERPROOF JACKETS AND PANTS; WATERPROOF LEATHER SHOES; WATERPROOF LEATHER SHOES AND BOOTS; WEARABLE GARMENTS AND CLOTHING, NAMELY, SHIRTS; WELTS FOR BOOTS AND SHOES; WIND PANTS; WIND SHIRTS; WOMEN'S HATS AND HOODS; WOMEN'S SHOES; WOODEN SHOES; WOOLLEN SOCKS; WOOLLY HATS; WORK SHOES AND BOOTS; YOGA PANTS; YOGA SHIRTS (U.S. CLS. 22 AND 39).
FIRST USE 12-24-2008; IN COMMERCE 2-1-2010.
RAMONA ORTIGA, EXAMINING ATTORNEY

SN 85-134,724. MOON PRODUCTS, LLC, SALT LAKE CITY, UT. FILED 9-21-2010.

MALOLO

THE MARK CONSISTS OF STANDARD CHARACTERS WITHOUT CLAIM TO ANY PARTICULAR FONT, STYLE, SIZE, OR COLOR.

FOR EXERCISE CLOTHING, NAMELY, SWEAT PANTS, SWEAT SHIRTS, SWEAT SUITS, T-SHIRTS, JACKETS, WARM-UP SUITS, SHORTS, HEADBANDS, WRISTBANDS, SWIM WEAR, FOOTWEAR, GLOVES, RAIN WEAR, SUN VISORS, LEGGINGS, LEG WARMERS, TIGHTS, LEOTARDS, BODY SUITS, SCARVES, PULLOVERS, ANORAKS, PARKAS, VESTS, RAIN SUITS, DISTRIBUTED PRIMARILY IN CONNECTION WITH THE PROMOTION OF MASSAGE, EXERCISE AND STRESS MANAGEMENT (U.S. CLS. 22 AND 39).
JAMES LOVELACE, EXAMINING ATTORNEY

SN 85-166,604. URBAN ROYALTY L.L.C., FARMINGTON HILLS, MI. FILED 11-1-2010.

Urban  Royalty

THE MARK CONSISTS OF THE STYLIZED TEXT "URBAN ROYALTY" WITH A SHIELD, A CROWN AND THE STYLIZED TEXT "URBAN ROYALTY UR".

FOR BELTS; BOOTS; DRESSES; HATS; JEANS; PANTS; SHIRTS; SHOES; SKIRTS; SOCKS; SWEATERS; T-SHIRTS; UNDERWEAR (U.S. CLS. 22 AND 39).
KRISTIN CARLSON, EXAMINING ATTORNEY

CLASS 25—(Continued).

SN 85-192,143. CUPID FOUNDATIONS, INC., NEW YORK, NY. FILED 12-7-2010.

BETTER WHENEVER

THE MARK CONSISTS OF STANDARD CHARACTERS WITHOUT CLAIM TO ANY PARTICULAR FONT, STYLE, SIZE, OR COLOR.

FOR UNDERGARMENTS (U.S. CLS. 22 AND 39).
BARBARA BROWN, EXAMINING ATTORNEY

SN 85-198,483. LE, CHRISTINE THI, DBA HEALTHCARE DIVAS, SAN DIEGO, CA. FILED 12-15-2010.

HEALTHCARE DIVAS

THE MARK CONSISTS OF THE WORDING "HEALTHCARE DIVAS" ABOVE THE DESIGN OF A CIRCLE CONTAINING A CROSS WITH A CROWN ON TOP.

FOR TOPS, PANTS, SCRUBS NOT FOR MEDICAL PURPOSES, T-SHIRTS, TANKS, JACKETS, HATS; ACTIVEWEAR, NAMELY, SHIRTS, SHORTS, SWEATSHIRTS, JACKETS, SOCKS, HATS, SWIMWEAR (U.S. CLS. 22 AND 39).

FIRST USE 1-6-2008; IN COMMERCE 8-15-2008.
KAREN BRACEY, EXAMINING ATTORNEY

SN 85-203,787. TWINS ENTERPRISE, INC., DEDHAM, MA. FILED 12-22-2010.

47

THE MARK CONSISTS OF STANDARD CHARACTERS WITHOUT CLAIM TO ANY PARTICULAR FONT, STYLE, SIZE, OR COLOR.

FOR ATHLETIC UNIFORMS; BABY BIBS NOT OF PAPER; BANDANAS; BASEBALL CAPS AND HATS; BOTTOMS; CAPS; CARDIGANS; EAR BANDS; EAR MUFFS; GLOVES; HATS; HEADWEAR; JACKETS; JEANS; JERSEYS; MITTENS; PAJAMAS; PANTS; PULL-OVERS; SHIRTS; SHORTS; SOCKS; SWEATERS; SWEATPANTS; SWEATSHIRTS; TANK TOPS; TOPS; TRACK JACKETS; TRACK PANTS; UNDERWEAR (U.S. CLS. 22 AND 39).

CHRISTOPHER BUONGIORNO, EXAMINING ATTORNEY

CLASS 25—(Continued).

SN 85-203,798. TWINS ENTERPRISE, INC., DEDHAM, MA. FILED 12-22-2010.

FORTY SEVEN

THE MARK CONSISTS OF STANDARD CHARACTERS WITHOUT CLAIM TO ANY PARTICULAR FONT, STYLE, SIZE, OR COLOR.

FOR ATHLETIC UNIFORMS; BABY BIBS NOT OF PAPER; BANDANAS; BASEBALL CAPS AND HATS; BOTTOMS; CAPS; CARDIGANS; EAR MUFFS; EARBANDS; GLOVES; HATS; HEADWEAR; JACKETS; JEANS; JERSEYS; MITTENS; PAJAMAS; PANTS; PULL-OVERS; SHIRTS; SHORTS; SWEAT PANTS; SWEATERS; SWEATSHIRTS; TANK TOPS; TOPS; TRACK JACKETS; TRACK PANTS; UNDERWEAR (U.S. CLS. 22 AND 39).

CHRISTOPHER BUONGIORNO, EXAMINING ATTORNEY

SN 85-238,437. WALKER, CHRISTOPHER I, GREENWICH, CT. FILED 2-9-2011.

MotionSport

THE MARK CONSISTS OF STANDARD CHARACTERS WITHOUT CLAIM TO ANY PARTICULAR FONT, STYLE, SIZE, OR COLOR.

FOR ATHLETIC APPAREL, NAMELY, SHIRTS, PANTS, JACKETS, FOOTWEAR, HATS AND CAPS, ATHLETIC UNIFORMS (U.S. CLS. 22 AND 39).

SUSAN STIGLITZ, EXAMINING ATTORNEY

SN 85-238,464. KOMEX INTERNATIONAL, INC., LOS ANGELES, CA. FILED 2-9-2011.

bluBlack

THE MARK CONSISTS OF "BLUBLACK" IN A STYLIZED MANNER.

FOR CLOTHING, NAMELY, JEANS, PANTS, SHORTS, SKIRTS, DENIM JACKETS, CAPRIS, FLOODS IN THE NATURE OF PANTS, OVERALLS, SHORTALLS, MINISKIRTS, T-SHIRTS, KNITS, KNIT TOPS AND DRESSES (U.S. CLS. 22 AND 39).

ANDREW LEASER, EXAMINING ATTORNEY

CLASS 25—(Continued).

SN 85-263,583. MUNGUÍA, LUIS EDUARDO, BOISE, ID.
FILED 3-10-2011.



THE MARK CONSISTS OF A SKULL NEXT TO THE WORDS "RUTHLESS 101".
FOR HATS; HOODED SWEAT SHIRTS; SHORTS; T-SHIRTS (U.S. CLS. 22 AND 39).
WANDA KAY PRICE, EXAMINING ATTORNEY

CLASS 25—(Continued).

SN 85-274,535. MASCOTTE HOLDINGS, INC., NEW YORK, NY. FILED 3-23-2011.

YEEZI

SN 85-272,504. FRESNEL SAMSON CARENA, PHILADELPHIA, PA. FILED 3-21-2011.

Frescar

THE MARK CONSISTS OF STANDARD CHARACTERS WITHOUT CLAIM TO ANY PARTICULAR FONT, STYLE, SIZE, OR COLOR.

FOR ATHLETIC APPAREL, NAMELY, SHIRTS, PANTS, JACKETS, FOOTWEAR, HATS AND CAPS, ATHLETIC UNIFORMS; BASEBALL CAPS AND HATS; CHEF'S HATS; FUR HATS; HAT BANDS; HATS; HATS FOR INFANTS, BABIES, TODDLERS AND CHILDREN; HEADGEAR, NAMELY, HAT (U.S. CLS. 22 AND 39).
RAMONA ORTIGA, EXAMINING ATTORNEY

SN 85-274,411. B. BOMAN & CO., INC., TETERBORO, NJ. FILED 3-23-2011.

BOLTON'S SPORT

THE MARK CONSISTS OF STANDARD CHARACTERS WITHOUT CLAIM TO ANY PARTICULAR FONT, STYLE, SIZE, OR COLOR.

OWNER OF U.S. REG. NO. 1,210,999.
NO CLAIM IS MADE TO THE EXCLUSIVE RIGHT TO USE "SPORT", APART FROM THE MARK AS SHOWN.
FOR T-SHIRTS (U.S. CLS. 22 AND 39).
FIRST USE 11-0-2005; IN COMMERCE 11-0-2005.
CARRIE GENOVESE, EXAMINING ATTORNEY

THE MARK CONSISTS OF STANDARD CHARACTERS WITHOUT CLAIM TO ANY PARTICULAR FONT, STYLE, SIZE, OR COLOR.

THE NAME SHOWN IN THE MARK IDENTIFIES KANYE WEST A LIVING INDIVIDUAL, WHOSE CONSENT TO REGISTER IS MADE OF RECORD.

FOR CLOTHING, NAMELY, SHIRTS, T-SHIRTS, UNDER SHIRTS, NIGHT SHIRTS, RUGBY SHIRTS, POLO SHIRTS, CARDIGANS, JERSEYS, UNIFORMS, SCRUBS NOT FOR MEDICAL PURPOSES, SMOCKS, DRESS SHIRTS, PANTS, TROUSERS, SLACKS, JEANS, CULOTTES, CARGO PANTS, STRETCH PANTS, DENIM JEANS, OVERALLS, COVERALLS, JUMPERS, JUMP SUITS, SHORTS, BOXER SHORTS, TOPS, STRETCH TOPS, TUBE TOPS, CROP TOPS, TANK TOPS, TANKINIS, HALTER TOPS, SWEAT SHIRTS, HOODED SWEAT SHIRTS, SWEAT SHORTS, SWEAT PANTS, WRAPS, WARM-UP SUITS, JOGGING SUITS, TRACK SUITS, PLAY SUITS, BLOUSES, SKIRTS, DRESSES, SWEATERS, VESTS, FLEECE VESTS, PULLOVERS, SNOW SUITS, PARKAS, CAPES, ANORAKS, PONCHOS, CLOAKS, SHRUGS, JACKETS, REVERSIBLE JACKETS, WIND-RESISTANT JACKETS, SHELL JACKETS, SPORTS JACKETS, GOLF AND SKI JACKETS, JEAN JACKETS, COATS, HEAVY COATS, OVER COATS, BLAZERS, SUITS, TURTLENECKS, CLOTH SKI BIBS, SWIMWEAR, BEACHWEAR, TENNIS WEAR, SURF WEAR, SKI WEAR, LAYETTES, INFANTWEAR, INFANTS SLEEPERS, BOOTIES, BABY BIBS NOT OF PAPER, CLOTH DIAPERS, CAPS, SWIM CAPS, BERETS, BEANIES, HATS, VISORS, HEADBANDS, WRIST BANDS, SWEAT BANDS, HEADWEAR, EAR MUFFS, APRONS, SCARVES, BANDANAS, BELTS, SUSPENDERS, NECKWEAR, TIES, NECKERCHIEFS, POCKET SQUARES, ASCOTS, UNDERWEAR, THERMAL UNDERWEAR, LONG UNDERWEAR, BRIEFS, SWIM AND BATHING TRUNKS, BRAS, THONGS, G-STRINGS, SINGLETTS, SOCKS, LOUNGEWEAR, ROBES, UNDERCLOTHES, PJAMAS, SLEEPWEAR, NIGHT GOWNS, NIGHTIES, LINGERIE, LEG WARMERS, HOSIERY, PANTYHOSE, BODY STOCKINGS, KNEE HIGHS, LEGGINGS, TIGHTS, GLOVES, MITTENS, RAIN SLICKERS, RAINWEAR, FOOTWEAR, SHOES, SNEAKERS, BOOTS, GALOSHES, SANDALS, FLIP-FLOPS, AND SLIPPERS (U.S. CLS. 22 AND 39).
CHARISMA HAMPTON, EXAMINING ATTORNEY

CLASS 25—(Continued).

SN 85-277,956. COURAGE SPORTS, INC., FAIRACRES, NM. FILED 3-26-2011.

PANAMANIANCS

THE MARK CONSISTS OF STANDARD CHARACTERS WITHOUT CLAIM TO ANY PARTICULAR FONT, STYLE, SIZE, OR COLOR.

FOR CLOTHING, NAMELY, SHIRTS, PANTS, FOOTWEAR; HEADGEAR, NAMELY, HATS; MEN'S, WOMEN'S AND CHILDREN'S FITNESS, ATHLETIC AND CASUAL CLOTHING, NAMELY, SHOES; SHIRTS, T-SHIRTS, SWEATSHIRTS, SOCKS, PANTS, TROUSERS, SHORTS, SWEATPANTS, CAPS, JOGGING SUITS, WIND AND/OR RAIN RESISTANT JACKETS, JACKETS, COATS AND PARKAS (U.S. CLS. 22 AND 39).

DANNEAN HETZEL, EXAMINING ATTORNEY

SN 85-283,824. DIRTEE APPAREL INC, PLAIN CITY, UT. FILED 4-1-2011.



NO CLAIM IS MADE TO THE EXCLUSIVE RIGHT TO USE "USA LEATHER GOODS", APART FROM THE MARK AS SHOWN.

THE NAME(S), PORTRAIT(S), AND/OR SIGNATURE(S) SHOWN IN THE MARK IDENTIFIES ROBERT GLENN BULLOCK, WHOSE CONSENT(S) TO REGISTER IS MADE OF RECORD.

THE MARK CONSISTS OF THE LITERAL ELEMENTS "R.G. BULLCO U.S.A. LEATHER GOODS" WHEREIN THE IMAGE IS OF AN OVAL SHAPE WITH THREE SMALL STYLIZED HORNS ON EACH SIDE AND ONE BIG STYLIZED HORN ON EACH SIDE AND IN THE MIDDLE OF THE OVAL THERE IS A SKULL OF A BULL AND "R.G. BULLCO" IS WRITTEN ABOVE AN OVAL SHAPE AND "U.S.A. LEATHER GOODS" ARE WRITTEN BELOW AN OVAL SHAPE AS SHOWN IN THE MARK.

FOR BELTS AND GLOVES MADE OF LEATHER (U.S. CLS. 22 AND 39).

FIRST USE 11-1-2010; IN COMMERCE 11-1-2010.
BARBARA GAYNOR, EXAMINING ATTORNEY

CLASS 25—(Continued).

SN 85-288,134. LI, JOSEPH, CITY OF INDUSTRY, CA. FILED 4-6-2011.



OWNER OF U.S. REG. NO. 3,063,703.

THE MARK CONSISTS OF LETTERS "L" AND "A" IN THE FIRST ROW AND LETTERS "M" AND "O" IN THE SECOND ROW SUCH THAT THE LETTERS "L" AND "M" ARE ALIGNED IN A FIRST COLUMN AND THE LETTERS "A" AND "O" ARE ALIGNED IN THE SECOND COLUMN, AND A SHEEP PLACED INSIDE THE LETTER "O". THE MARK IS ON A RECTANGULAR BACKGROUND.

THE WORDING "LAMO" HAS NO MEANING IN A FOREIGN LANGUAGE.

FOR FOOTWEAR, NAMELY, SHOES, BOOTS, BOOTIES, ANKLE WRAP SHOES, CLOGS, MOCCASINS, SCUFFS IN THE NATURE OF SLIPPERS WITH NO HEEL FITTINGS, SANDALS, FLIP-FLOPS, THONGS, JANDALS, SLIPPERS, PLUGGERS IN THE NATURE OF FLIP-FLOPS, SLIDES IN THE NATURE OF SHOES WITH NO HEEL FITTINGS, AND SOCKS (U.S. CLS. 22 AND 39).

FIRST USE 5-31-2010; IN COMMERCE 5-31-2010.

KATHLEEN M. VANSTON, EXAMINING ATTORNEY

SN 85-292,670. YA PUES MANUFACTURING S.R.L., LA PAZ, BOLIVIA, FILED 4-12-2011.

THE MARK CONSISTS OF THE WORDS "YA PUES" WITH AN EXCLAMATION POINT IN STYLIZED FORM, GIVING THE MARK AN ABRASSED OR WEATHERED APPEARANCE. IN THE LETTER "P" APPEARS THE PROFILE OF AN ALPACA HEAD.

THE ENGLISH TRANSLATION OF "YA PUES!" IN THE MARK IS "COME ON!"

FOR CLOTHING, NAMELY, SWEATERS, CARDIGANS, HOODED SWEATSHIRTS, DRESSES, SHAWLS, SCARVES, GLOVES, HATS, CAPS, VESTS, AND SOCKS (U.S. CLS. 22 AND 39).

STEVEN JACKSON, EXAMINING ATTORNEY

CLASS 25—(Continued).

SN 85-296,339. ARMY NATIONAL GUARD, ARLINGTON, VA. FILED 4-15-2011.

YOU CAN

THE MARK CONSISTS OF STANDARD CHARACTERS WITHOUT CLAIM TO ANY PARTICULAR FONT, STYLE, SIZE, OR COLOR.

OWNER OF U.S. REG. NO. 2,920,854.
FOR CLOTHING, NAMELY, FLEECE JACKETS, CAPS, T-SHIRTS, DRESS SHIRTS, POLO SHIRTS, SHORTS, WARM UP SUITS, SWEATSHIRTS, SWEAT PANTS (U.S. CLS. 22 AND 39).

MICHAEL TANNER, EXAMINING ATTORNEY

SN 85-296,378. ARMY NATIONAL GUARD, ARLINGTON, VA. FILED 4-15-2011.

ALWAYS READY, ALWAYS THERE

THE MARK CONSISTS OF STANDARD CHARACTERS WITHOUT CLAIM TO ANY PARTICULAR FONT, STYLE, SIZE, OR COLOR.

FOR CLOTHING, NAMELY, FLEECE JACKETS, CAPS, T-SHIRTS, DRESS SHIRTS, POLO SHIRTS, SHORTS, WARM UP SUITS, SWEATSHIRTS, SWEAT PANTS (U.S. CLS. 22 AND 39).

MICHAEL TANNER, EXAMINING ATTORNEY

SN 85-296,416. ARMY NATIONAL GUARD, ARLINGTON, VA. FILED 4-15-2011.



OWNER OF U.S. REG. NOS. 2,920,854, 3,222,325 AND 3,244,342.

THE MARK CONSISTS OF THE STYLIZED WORDING "ARMY NATIONAL GUARD YOU CAN" AS WELL AS THE DEPICTION OF STYLIZED FLAG. THE TERM "NATIONAL" APPEARS ABOVE THE TERM "GUARD" WITH THE WORDING "YOU CAN" APPEARING BELOW THE

CLASS 25—(Continued).

TERM "GUARD". TO THE RIGHT OF THE WORDING "NATIONAL" APPEARS THE DEPICTION OF A STYLIZED FLUTTERING FLAG. TO THE LEFT OF THE WORDING "NATIONAL GUARD" APPEARS THE TERM "ARMY" WRITTEN VERTICALLY AND SURROUNDED BY A RECTANGULAR BAR. THE WORDING "ARMY NATIONAL GUARD YOU CAN" AS WELL AS THE RECTANGULAR BAR AND STYLIZED FLAG ARE ALL DEPICTED ON A BACKGROUND DESIGN CONSISTING OF SMALL BARS AND SHADING.

SEC. 2(F) AS TO "NATIONAL GUARD".
FOR CLOTHING, NAMELY, FLEECE JACKETS, CAPS, T-SHIRTS, DRESS SHIRTS, POLO SHIRTS, SHORTS, WARM UP SUITS, SWEATSHIRTS, SWEAT PANTS (U.S. CLS. 22 AND 39).

MICHAEL TANNER, EXAMINING ATTORNEY

SN 85-297,013. MARY OF BETHANY, INC., CEDAR PARK, TX. FILED 4-16-2011.

Live Worship Capital

THE MARK CONSISTS OF STANDARD CHARACTERS WITHOUT CLAIM TO ANY PARTICULAR FONT, STYLE, SIZE, OR COLOR.

FOR T-SHIRTS (U.S. CLS. 22 AND 39).
FIRST USE 4-15-2011; IN COMMERCE 4-15-2011.

MICHAEL ENGEL, EXAMINING ATTORNEY

SN 85-301,255. ILANA WOLF, INC., NEW YORK, NY. FILED 4-21-2011.

ILANA WOLF

THE MARK CONSISTS OF STANDARD CHARACTERS WITHOUT CLAIM TO ANY PARTICULAR FONT, STYLE, SIZE, OR COLOR.

THE NAME(S), PORTRAIT(S), AND/OR SIGNATURE(S) SHOWN IN THE MARK IDENTIFIES "ILANA WOLF", WHOSE CONSENT(S) TO REGISTER IS MADE OF RECORD.

FOR WOMEN'S CLOTHING AND ACCESSORIES, NAMELY, JACKETS, TOPS, PANTS, SKIRTS, SHAWLS, CAPES, AND SCARVES (U.S. CLS. 22 AND 39).

FIRST USE 8-0-1995; IN COMMERCE 8-0-1995.

JAMES GRIFFIN, EXAMINING ATTORNEY

CLASS 25—(Continued).

SN 85-301,274. ILANA WOLF, INC., NEW YORK, NY. FILED 4-21-2011.

ILANA

THE MARK CONSISTS OF STANDARD CHARACTERS WITHOUT CLAIM TO ANY PARTICULAR FONT, STYLE, SIZE, OR COLOR.

FOR WOMEN'S CLOTHING AND ACCESSORIES, NAMELY, JACKETS, TOPS, PANTS, SKIRTS, SHAWLS, CAPES, AND SCARVES (U.S. CLS. 22 AND 39).
FIRST USE 5-0-2010; IN COMMERCE 5-0-2010.
JAMES GRIFFIN, EXAMINING ATTORNEY

SN 85-301,674. LEHMAN BROTHERS HOLDINGS INC., NEW YORK, NY. FILED 4-21-2011.

SETAI

THE MARK CONSISTS OF STANDARD CHARACTERS WITHOUT CLAIM TO ANY PARTICULAR FONT, STYLE, SIZE, OR COLOR.

FOR CLOTHING, NAMELY, SHIRTS, PANTS, JEANS, SHORTS, BELTS, VESTS, SHOES, LONG SLEEVE SHIRTS, DRESS SHIRTS, DRESSES, SWEATERS, UNDERWEAR, BATHING SUITS, BATHING TRUNKS, JACKETS AND COATS; FOOTWEAR OTHER THAN SLIPPERS; SPORTSWEAR, NAMELY, TEE SHIRTS, TANK TOPS, PANTS, JEANS, SHORTS, SWEATSHIRTS, HOODED SWEATSHIRTS, POLO KNIT TOPS, BEACHWEAR, AND WOVEN TOPS; AND HEADGEAR, NAMELY, HATS, CAPS, VISORS AND HEADBANDS (U.S. CLS. 22 AND 39).

KATHERINE CHANG, EXAMINING ATTORNEY

SN 85-305,890. JAKKS PACIFIC, INC., MALIBU, CA. FILED 4-27-2011.

IN THE SHADOWS

THE MARK CONSISTS OF STANDARD CHARACTERS WITHOUT CLAIM TO ANY PARTICULAR FONT, STYLE, SIZE, OR COLOR.

FOR HALLOWEEN AND MASQUERADE COSTUMES, AND ACCESSORIES SOLD AS A UNIT IN CONNECTION THEREWITH, NAMELY, MASKS, OVERSHOES, GLOVES, HATS, BELTS, BANDANNAS, PLAYSUITS, HEADWEAR, UNDERWEAR, FOOTWEAR, HOSE, AND WIGS; COSTUMES AND COSTUME ACCESSORIES SOLD AS A UNIT IN CONNECTION THEREWITH, NAMELY, PROPS, JEWELRY, HEADWEAR, FOOTWEAR, MASKS; COSTUMES FOR USE IN ROLE-PLAYING GAMES (U.S. CLS. 22 AND 39).

LINDSEY RUBIN, EXAMINING ATTORNEY

CLASS 25—(Continued).

SN 85-310,418. MOMS INTO FITNESS, INC., SAINT LOUIS, MO. FILED 5-2-2011.

Pretty Fierce

THE MARK CONSISTS OF STANDARD CHARACTERS WITHOUT CLAIM TO ANY PARTICULAR FONT, STYLE, SIZE, OR COLOR.

FOR WOMEN'S CLOTHING, NAMELY, SHIRTS, DRESSES, SKIRTS, BLOUSES (U.S. CLS. 22 AND 39).
FIRST USE 4-1-2011; IN COMMERCE 4-1-2011.
PRISCILLA MILTON, EXAMINING ATTORNEY

SN 85-310,503. ALLYSON AMES COMPANY, INC., CORONA DEL MAR, CA. FILED 5-3-2011.

WONDERLICIOUS

THE MARK CONSISTS OF STANDARD CHARACTERS WITHOUT CLAIM TO ANY PARTICULAR FONT, STYLE, SIZE, OR COLOR.

OWNER OF U.S. REG. NO. 3,629,516.
FOR CLOTHING, NAMELY, SHIRTS, HATS, APRONS, BABY BIBS NOT OF PAPER, LOUNGEWEAR, SWIMSUITS, SOCKS, SHOES, TANK TOPS, JACKETS, SCARFS, BRAS, PANTIES, SLIPS, JEANS, PANTS, SHORTS, YOGA SHIRTS, YOGA PANTS, TENNIS WEAR (U.S. CLS. 22 AND 39).

FIRST USE 1-1-2005; IN COMMERCE 1-1-2011.
JANICE L. MCMORROW, EXAMINING ATTORNEY

SN 85-310,803. MUSSOLINO, LLC, TA GREAT HUNT OUTFITTERS, HAGERSTOWN, MD. FILED 5-3-2011.



NO CLAIM IS MADE TO THE EXCLUSIVE RIGHT TO USE "GREAT HUNT OUTFITTERS", APART FROM THE MARK AS SHOWN.

THE COLOR(S) ORANGE, YELLOW, BLACK, GRAY, BROWNISH GRAY, AND WHITE IS/ARE CLAIMED AS A FEATURE OF THE MARK.

THE MARK CONSISTS OF FOUR CONCENTRIC CIRCLES; THE OUTERMOST CIRCLE IN BLACK; THE SEC-

CLASS 25—(Continued).

OND CIRCLE IN BROWNISH GRAY AND CONTAINS THE WORDING "GREAT HUNT OUTFITTERS" IN WHITE WITH TWO GRAY STARS AT EITHER END OF THE WORDING; THE THIRD CIRCLE IN BLACK; AND THE FOURTH AND INNER MOST CIRCLE CONTAINS A DESIGN ELEMENT CONSISTING OF A BOW HUNTER IN BLACK WITH ORANGE EYES STANDING ON THE BRANCH OF A BLACK TREE WITH AN ORANGE AND YELLOW SUNRISE BEHIND HIM; THE WORDING "THE ULTIMATE PREDATOR" APPEAR IN ORANGE IN A BLACK RECTANGLE WITH ROUNDED ENDS WHICH IS POSITIONED AT THE BOTTOM OF THE CONCENTRIC CIRCLES.

FOR SHIRTS, JACKETS, PANTS AND HATS (U.S. CLS. 22 AND 39).

BILL DAWE, EXAMINING ATTORNEY

SN 85-315,094. VOJOA CLOTHING COMPANY, LLC, DBA (RYO) RIDE YOUR OWN CLOTHING COMPANY, NORTH ARLINGTON, NJ. FILED 5-7-2011.

RYO

THE MARK CONSISTS OF STANDARD CHARACTERS WITHOUT CLAIM TO ANY PARTICULAR FONT, STYLE, SIZE, OR COLOR.

FOR MEN'S AND WOMEN'S CLOTHING, NAMELY, SWIMWEAR, BATHING SUITS, BIKINIS, COVER-UPS, TANK TOPS, SHIRTS, SKIRTS, DRESSES, SHORTS, JUMPERS, CAPRIS, LEGGINGS, PAJAMAS, ROBES, JERSEYS, SOCKS, UNDERWEAR, GLOVES, BELTS, TIES, VESTS; HEADWEAR, NAMELY, CAPS AND VISORS; AND FOOTWEAR, NAMELY, SANDALS, SLIPPERS, BOOTS, AND ATHLETIC SHOES, T-SHIRTS, SWEATSHIRTS, SWEATPANTS, SWIMTRUNKS, WALKING SHORTS, PANTS, UNDERWEAR, TANK TOPS, SHIRTS, JACKETS AND HATS (U.S. CLS. 22 AND 39).

FIRST USE 1-10-2009; IN COMMERCE 3-15-2010.

SALLY SHIH, EXAMINING ATTORNEY

SN 85-316,799. SOLIDCOLORNECKTIES.COM, INC, MUNDLEIN, IL. FILED 5-10-2011.

Alexander Logan Neckwear

THE MARK CONSISTS OF STANDARD CHARACTERS WITHOUT CLAIM TO ANY PARTICULAR FONT, STYLE, SIZE, OR COLOR.

NO CLAIM IS MADE TO THE EXCLUSIVE RIGHT TO USE "NECKWEAR", APART FROM THE MARK AS SHOWN.

THE NAME(S), PORTRAIT(S), AND/OR SIGNATURE(S) SHOWN IN THE MARK DOES NOT IDENTIFY A PARTICULAR LIVING INDIVIDUAL.

FOR NECKTIES (U.S. CLS. 22 AND 39).

FIRST USE 4-15-2008; IN COMMERCE 4-15-2008.

MARIA-VICTORIA SUAREZ, EXAMINING ATTORNEY

CLASS 25—(Continued).

SN 85-318,578. KARMAN INC., AURORA, CO. FILED 5-11-2011.

WEAR THE WEST

THE MARK CONSISTS OF STANDARD CHARACTERS WITHOUT CLAIM TO ANY PARTICULAR FONT, STYLE, SIZE, OR COLOR.

FOR FOOTWEAR, HEADWEAR AND CLOTHING, NAMELY, BLOUSES, COATS, DRESSES, JACKETS, JEANS, PANTS, SHIRTS, SHORTS, SKIRTS, SWEATERS, SWEATSHIRTS AND T-SHIRTS (U.S. CLS. 22 AND 39).

MARY CRAWFORD, EXAMINING ATTORNEY

SN 85-321,334. YOLANDA ADAMS, HOUSTON, TX. FILED 5-15-2011.

Yolanda's Clozet

THE MARK CONSISTS OF STANDARD CHARACTERS WITHOUT CLAIM TO ANY PARTICULAR FONT, STYLE, SIZE, OR COLOR.

THE NAME "YOLANDA" IDENTIFIES YOLANDA ADAMS, A LIVING INDIVIDUAL WHOSE CONSENT IS OF RECORD.

FOR CLOTHING LINE PRODUCED BY GOSPEL SINGING ARTIST YOLANDA ADAMS, NAMELY, T-SHIRTS, JEANS, PANTS, SWEAT SHIRTS, SWEATERS, SHORTS, SHIRTS, SKIRTS, AND BLOUSES (U.S. CLS. 22 AND 39).

APRIL HESIK, EXAMINING ATTORNEY

SN 85-326,950. BUELL, LESLIE A, DBA CHICS WITH PONIES, SUGAR LAND, TX. FILED 5-22-2011.

Chics with Ponies

THE MARK CONSISTS OF STANDARD CHARACTERS WITHOUT CLAIM TO ANY PARTICULAR FONT, STYLE, SIZE, OR COLOR.

FOR HATS; HEADGEAR, NAMELY, CAPS; LEATHER BELTS; PANTS; POLO SHIRTS; SHIRTS; SHIRTS AND SHORT-SLEEVED SHIRTS; SHORT-SLEEVED OR LONG-SLEEVED T-SHIRTS; WEARABLE GARMENTS AND CLOTHING, NAMELY, SHIRTS; WIND SHIRTS; WOMEN'S CLOTHING, NAMELY, SHIRTS, DRESSES, SKIRTS, BLOUSES (U.S. CLS. 22 AND 39).

FIRST USE 11-0-2010; IN COMMERCE 2-0-2011.

JACQUELINE A. LAVINE, EXAMINING ATTORNEY

CLASS 25—(Continued).

SN 85-329,508. KJC, LLC, ST. LOUIS, MO. FILED 5-25-2011.

**KATHERINE JESSICA
COLLECTIONS**

THE MARK CONSISTS OF STANDARD CHARACTERS WITHOUT CLAIM TO ANY PARTICULAR FONT, STYLE, SIZE, OR COLOR.

NO CLAIM IS MADE TO THE EXCLUSIVE RIGHT TO USE "COLLECTIONS", APART FROM THE MARK AS SHOWN.

THE NAME(S), PORTRAIT(S), AND/OR SIGNATURE(S) SHOWN IN THE MARK IDENTIFIES "KATHERINE JESSICA" WEINSTEIN, WHOSE CONSENT(S) TO REGISTER IS MADE OF RECORD.

FOR HEADBANDS; HEADPIECES, NAMELY, HEADWEAR (U.S. CLS. 22 AND 39).

FIRST USE 5-31-2010; IN COMMERCE 5-31-2010.
CIMMERIAN COLEMAN, EXAMINING ATTORNEY

CLASS 25—(Continued).

SN 85-331,727. GRENDENE S.A., 95.180-FARROUPILHA RS, BRAZIL, FILED 5-26-2011.

MELISSA ACADEMY

THE MARK CONSISTS OF STANDARD CHARACTERS WITHOUT CLAIM TO ANY PARTICULAR FONT, STYLE, SIZE, OR COLOR.

PRIORITY CLAIMED UNDER SEC. 44(D) ON BRAZIL APPLICATION NO. 903172305, FILED 11-26-2010.

OWNER OF U.S. REG. NOS. 2,526,595, 2,737,154 AND 3,047,672.

FOR FOOTWEAR, NAMELY, INJECTION-MILDED PLASTIC SANDALS, SNEAKERS, AND CLOGS (U.S. CLS. 22 AND 39).

SHANNON TWOHIG, EXAMINING ATTORNEY

SN 85-331,449. MORI LEE LLC, BOCA RATON, FL. FILED 5-26-2011.

VENI INFANTINO

THE MARK CONSISTS OF STANDARD CHARACTERS WITHOUT CLAIM TO ANY PARTICULAR FONT, STYLE, SIZE, OR COLOR.

THE NAME(S), PORTRAIT(S), AND/OR SIGNATURE(S) SHOWN IN THE MARK IDENTIFIES "VENI INFANTINO", WHOSE CONSENT(S) TO REGISTER IS MADE OF RECORD.

FOR CLOTHING, NAMELY, DRESSES (U.S. CLS. 22 AND 39).

MARY BOAGNI, EXAMINING ATTORNEY

SN 85-336,090. INNOVATIVE FASHION GROUP CORP., NEW YORK, NY. FILED 6-2-2011.

APANA

THE MARK CONSISTS OF STANDARD CHARACTERS WITHOUT CLAIM TO ANY PARTICULAR FONT, STYLE, SIZE, OR COLOR.

FOR CLOTHING, NAMELY, PANTS, SHORTS, SKORTS, TOPS, SWIMWEAR, SOCKS, AND OUTERWEAR, NAMELY, COATS, JACKETS, WIND RESISTANT JACKETS, RAINWEAR, HOOD SWEATSHIRTS AND PRAMS SUITS (U.S. CLS. 22 AND 39).

LINDA ORNDORFF, EXAMINING ATTORNEY

SN 85-331,697. GRENDENE S.A., 95.180 FARROUPILHA RS, BRAZIL, FILED 5-26-2011.



PRIORITY CLAIMED UNDER SEC. 44(D) ON BRAZIL APPLICATION NO. 903172305, FILED 11-26-2010.

OWNER OF U.S. REG. NOS. 2,526,595, 2,737,154 AND 3,047,672.

THE MARK CONSISTS OF THE WORDS "MELISSA ACADEMY" WITH A FANCIFUL PLACEMENT OF THE WORDS AND THE LETTER "Y".

FOR FOOTWEAR, NAMELY, INJECTION-MOLDED PLASTIC SANDALS, SNEAKERS, AND CLOGS (U.S. CLS. 22 AND 39).

SHANNON TWOHIG, EXAMINING ATTORNEY

SN 85-340,802. ARMY NATIONAL GUARD, ARLINGTON, VA. FILED 6-8-2011.

GUARD THE ENVIRONMENT

THE MARK CONSISTS OF STANDARD CHARACTERS WITHOUT CLAIM TO ANY PARTICULAR FONT, STYLE, SIZE, OR COLOR.

FOR CLOTHING, NAMELY, FLEECE JACKETS, CAPS, T-SHIRTS, DRESS SHIRTS, POLO SHIRTS, SHORTS, WARM UP SUITS, SWEATSHIRTS, SWEAT PANTS (U.S. CLS. 22 AND 39).

MICHAEL TANNER, EXAMINING ATTORNEY

CLASS 25—(Continued).

SN 85-353,317. MUNCHKIN, INC., NORTH HILLS, CA. FILED 6-22-2011.

MUNCHKIN

THE MARK CONSISTS OF STANDARD CHARACTERS WITHOUT CLAIM TO ANY PARTICULAR FONT, STYLE, SIZE, OR COLOR.

OWNER OF U.S. REG. NOS. 2,101,757, 3,578,309 AND OTHERS.

FOR INFANTWEAR, BODYSUITS, ONE-PIECE UNDERWEAR, SHIRTS, T-SHIRTS, PANTS, DRESSES, SKIRTS, SHORTS, UNDERSHIRTS, GOWNS, CREEPERS, COVERALLS, HOSIERY, SOCKS, SWADDLING CLOTHES, CLOTH BIBS, AND HATS (U.S. CLS. 22 AND 39).

ELIZABETH HUGHITT, EXAMINING ATTORNEY

SN 85-356,700. ANAMA, L.L.C., MIAMI, FL. FILED 6-27-2011.

SUGAR DADDY

THE MARK CONSISTS OF STANDARD CHARACTERS WITHOUT CLAIM TO ANY PARTICULAR FONT, STYLE, SIZE, OR COLOR.

FOR DRESSES; JACKETS; PANTS; SHORTS; SKIRTS; T-SHIRTS; TOPS (U.S. CLS. 22 AND 39).

BRIDGETT SMITH, EXAMINING ATTORNEY

SN 85-360,658. ROBERT J. ADAMS, PLANT CITY, FL. FILED 6-30-2011.

TREAD HEAD

THE MARK CONSISTS OF STANDARD CHARACTERS WITHOUT CLAIM TO ANY PARTICULAR FONT, STYLE, SIZE, OR COLOR.

FOR HATS, CAPS, VISORS, BANDANAS (U.S. CLS. 22 AND 39).

FLORENTINA BLANDU, EXAMINING ATTORNEY

CLASS 25—(Continued).

SN 85-361,564. UNIFI, INC., GREENSBORO, NC. FILED 7-1-2011.

REPREEVE

THE MARK CONSISTS OF STANDARD CHARACTERS WITHOUT CLAIM TO ANY PARTICULAR FONT, STYLE, SIZE, OR COLOR.

OWNER OF U.S. REG. NO. 2,391,497.

FOR YARN THAT IS AN INTEGRAL PART OF CLOTHING, NAMELY, SHIRTS, T-SHIRTS, PANTS, SHORTS, DRESSES, SKIRTS, SWEATSHIRTS, PULL-OVERS, JACKETS, VESTS, UNDERWEAR, SLEEPWEAR, LOUNGEWEAR, HATS AND CAPS, SOCKS, HOSIERY, AND SWIMWEAR (U.S. CLS. 22 AND 39).

FIRST USE 8-13-2001; IN COMMERCE 8-13-2001.

RAUL CORDOVA, EXAMINING ATTORNEY

SN 85-364,639. ST CYCLEWEAR / GALLOP LLC, EL CAJON, CA. FILED 7-6-2011.

WORLD JERSEYS

THE MARK CONSISTS OF STANDARD CHARACTERS WITHOUT CLAIM TO ANY PARTICULAR FONT, STYLE, SIZE, OR COLOR.

NO CLAIM IS MADE TO THE EXCLUSIVE RIGHT TO USE "JERSEYS", APART FROM THE MARK AS SHOWN.

FOR CLOTHING, NAMELY, BICYCLE JERSEYS, BICYCLE SHORTS, T-SHIRTS, JACKETS AND SOCKS (U.S. CLS. 22 AND 39).

FIRST USE 1-20-2001; IN COMMERCE 3-1-2001.

MICHELE SWAIN, EXAMINING ATTORNEY

SN 85-368,053. TA JUST B. REEL, ISELIN, NJ. FILED 7-11-2011.

LIVE

Love Is Very Empowering

THE MARK CONSISTS OF THE WORDING "LIVE" AND "LOVE IS VERY EMPOWERING" IN STYLIZED FONT.

FOR LONG-SLEEVED SHIRTS; POLO SHIRTS; SHIRTS; SHIRTS AND SHORT-SLEEVED SHIRTS; T-SHIRTS; TEE SHIRTS; WEARABLE GARMENTS AND CLOTHING, NAMELY, SHIRTS (U.S. CLS. 22 AND 39).

TEJBIR SINGH, EXAMINING ATTORNEY

CLASS 25—(Continued).

SN 85-368,179. VERA, JUAN, CANYON LAKE, CA. FILED 7-11-2011.



NO CLAIM IS MADE TO THE EXCLUSIVE RIGHT TO USE "MMA", APART FROM THE MARK AS SHOWN.

THE MARK CONSISTS OF THE WORDING "DOWN2-SCRAP" ABOVE AN OVAL CONTAINING THE DESIGN OF FISTS AND FINGERS FORMING THE LETTERS "MMA".

FOR CLOTHING, NAMELY, T-SHIRTS, SWEATSHIRTS, SHORTS, PANTS; HEADWEAR; AND FOOTWEAR (U.S. CLS. 22 AND 39).

MARC LEIPZIG, EXAMINING ATTORNEY

CLASS 25—(Continued).

SN 85-374,904. FINO, INC., CARTERSVILLE, GA. FILED 7-19-2011.



THE MARK CONSISTS OF THE WORDING "FINO FAILURE IS NO OPTION" IN STYLIZED FONT, WITH THE TERM "FINO" PLACED ABOVE THE WORDS "FAILURE IS NO OPTION".

FOR BATHING SUITS; BEANIES; CAPS; HATS; JACKETS; JERSEYS; SHORTS; SOCKS; SWEAT SHIRTS; SWEATPANTS; T-SHIRTS; TANK-TOPS; WRISTBANDS (U.S. CLS. 22 AND 39).

CURTIS FRENCH, EXAMINING ATTORNEY

SN 85-380,079. AKEEM HENRY, OWINGS MILLS, MD. FILED 7-25-2011.

Riches & Royalty Clothing

SN 85-373,842. WAGGING TONGUE TEES, LLC, GREENSBORO, NC. FILED 7-18-2011.



NO CLAIM IS MADE TO THE EXCLUSIVE RIGHT TO USE "TEES", APART FROM THE MARK AS SHOWN.

THE COLOR(S) BLACK, WHITE AND RED IS/ARE CLAIMED AS A FEATURE OF THE MARK.

THE MARK CONSISTS OF THE FACE OF A DOG IN BLACK WITH THE EARS, SUNGLASSES, NOSE, MOUTH AND TONGUE IN THE SHAPE OF AN EXCLAMATION POINT AND THE TONGUE IN RED STICKING OUT ON A WHITE BACKGROUND. THE WORDS "WAGGING TONGUE TEES" APPEARS IN BLACK UNDERNEATH THE DESIGN ELEMENT.

FOR T-SHIRTS (U.S. CLS. 22 AND 39).

FIRST USE 6-1-2011; IN COMMERCE 6-1-2011.

KIMBERLY PERRY, EXAMINING ATTORNEY

THE MARK CONSISTS OF STANDARD CHARACTERS WITHOUT CLAIM TO ANY PARTICULAR FONT, STYLE, SIZE, OR COLOR.

NO CLAIM IS MADE TO THE EXCLUSIVE RIGHT TO USE "CLOTHING", APART FROM THE MARK AS SHOWN.

FOR CLOTHING, NAMELY, T-SHIRT, HOODED SWEATSHIRTS, TANK TOPS, SWEATSHIRTS; HATS; SOCKS; WRISTBANDS (U.S. CLS. 22 AND 39).

FIRST USE 6-24-2011; IN COMMERCE 6-28-2011.

DEIRDRE ROBERTSON, EXAMINING ATTORNEY

SN 85-381,096. CREACIONES ALMAMIA, S.A., MEDELLIN, COLOMBIA, FILED 7-26-2011.



NO CLAIM IS MADE TO THE EXCLUSIVE RIGHT TO USE "SWIMWEAR", APART FROM THE MARK AS SHOWN.

THE MARK CONSISTS OF AN STYLIZED "ALMAMIA" WITH LINES COMING IN A CIRCLE AT THE END OF "MIA". THE WORD "SWIMWEAR" BELOW.

THE ENGLISH TRANSLATION OF "ALMAMIA" IN THE MARK IS "MYSOUL".

FOR BATHING SUITS; BATHROBES; BEACH COVER-UPS; BEACH FOOTWEAR; BEACH SHOES; DRESSES THAT MAY ALSO BE USED AS TOWELS; HATS; SANDALS AND BEACH SHOES (U.S. CLS. 22 AND 39).

FIRST USE 1-0-2011; IN COMMERCE 2-0-2011.

RONALD AIKENS, EXAMINING ATTORNEY

CLASS 25—(Continued).

SN 85-381,231. MYKEE B PRODUCTIONS INC., NEW YORK, NY. FILED 7-26-2011.

PUT A LITTLE MORE BOOTY ON
IT

THE MARK CONSISTS OF STANDARD CHARACTERS WITHOUT CLAIM TO ANY PARTICULAR FONT, STYLE, SIZE, OR COLOR.

FOR CLOTHING, NAMELY, TOPS, T-SHIRTS, SWEATSHIRTS, VESTS, BOTTOMS, PANTS, HEADWEAR, HATS, WRISTBANDS AND FOOTWEAR (U.S. CLS. 22 AND 39).

MICHAEL ENGEL, EXAMINING ATTORNEY

SN 85-383,631. REYNOSO, JUAN SALVADOR, HIDALGO, TX. FILED 7-28-2011.

Royal Bexar

THE MARK CONSISTS OF THE WORDS "ROYAL BEXAR". OVERLAPPING THE LETTER "B" THERE IS A THREE POINT CROWN ON TOP OF A HEART WHICH HAS A CUT OUT OF A TEDDY BEAR.

THE WORD(S) "BEXAR" HAS NO MEANING IN A FOREIGN LANGUAGE.

FOR WEARING APPAREL, CLOTHING, AND CLOTHING ACCESSORIES, NAMELY, TOPS, BOTTOMS, COATS, JACKETS, TIES, BELTS, HEADWEAR, FOOTWEAR, SWIMWEAR, SWEAT PANTS, SHORTS, SHIRTS, HATS AND CAPS (U.S. CLS. 22 AND 39).

DARRYL SPRUILL, EXAMINING ATTORNEY

SN 85-389,476. KOBRA INTERNATIONAL, LTD, NEW YORK, NY. FILED 8-4-2011.

ARTELIER NICOLE MILLER

THE MARK CONSISTS OF STANDARD CHARACTERS WITHOUT CLAIM TO ANY PARTICULAR FONT, STYLE, SIZE, OR COLOR.

OWNER OF U.S. REG. NOS. 3,304,479, 3,357,703 AND OTHERS.

THE NAME(S), PORTRAIT(S), AND/OR SIGNATURE(S) SHOWN IN THE MARK IDENTIFIES "NICOLE MILLER", WHOSE CONSENT(S) TO REGISTER IS MADE OF RECORD.

FOR HOSIERY; JACKETS; PANTS; SOCKS AND STOCKINGS; SWEATERS; SWIMWEAR; WOMEN'S CLOTHING, NAMELY, SHIRTS, DRESSES, SKIRTS, BLOUSES (U.S. CLS. 22 AND 39).

AHSEN KHAN, EXAMINING ATTORNEY

CLASS 25—(Continued).

SN 85-394,192. VOGUE NERO GLOBAL PVT LTD, HARYANA, INDIA, FILED 8-10-2011.

YOUNG THREADS

THE MARK CONSISTS OF STANDARD CHARACTERS WITHOUT CLAIM TO ANY PARTICULAR FONT, STYLE, SIZE, OR COLOR.

NO CLAIM IS MADE TO THE EXCLUSIVE RIGHT TO USE "THREADS", APART FROM THE MARK AS SHOWN.

FOR BOTTOMS; COATS; DRESSES; JACKETS; SWEATERS; TOPS; VESTS (U.S. CLS. 22 AND 39).

FIRST USE 9-1-2009; IN COMMERCE 9-1-2009.

SUZANNE BLANE, EXAMINING ATTORNEY

SN 85-398,473. BAZE, DAVID B, DBA UNITED BROTHERHOOD OF BEER DRINKERS UNION, LAKEWOOD, CA. FILED 8-15-2011.



THE MARK CONSISTS OF A CIRCLE WITH A WAVY FLAG INSIDE WITH A SCHOONER OF BEER WITHIN THE CIRCLE: "UNITED BROTHERHOOD OF BEER DRINKERS UNION" WRITTEN AROUND TOP OF THE CIRCLE AND "UNITED WE STAND DIVIDED WE FALL" WRITTEN AROUND THE BOTTOM; A SMALL SCHOONER OF BEER ON EACH SIDE OF THE CIRCLE THAT SAYS "LOCAL 32 OZ" INSIDE.

FOR T-SHIRTS (U.S. CLS. 22 AND 39).

FIRST USE 6-1-2011; IN COMMERCE 7-1-2011.

RAUL CORDOVA, EXAMINING ATTORNEY

SN 85-399,721. BABY CATE LLC, SCOTTSDALE, AZ. FILED 8-16-2011.

BABY CATE

THE MARK CONSISTS OF STANDARD CHARACTERS WITHOUT CLAIM TO ANY PARTICULAR FONT, STYLE, SIZE, OR COLOR.

NO CLAIM IS MADE TO THE EXCLUSIVE RIGHT TO USE "BABY", APART FROM THE MARK AS SHOWN.

FOR INFANT WEAR (U.S. CLS. 22 AND 39).

CARYN GLASSER, EXAMINING ATTORNEY

CLASS 25—(Continued).

SN 85-402,699. DILLARD'S, LITTLE ROCK, AR. FILED 8-19-2011.

Ultimate Modern Comfort

THE MARK CONSISTS OF STANDARD CHARACTERS WITHOUT CLAIM TO ANY PARTICULAR FONT, STYLE, SIZE, OR COLOR.

OWNER OF U.S. REG. NO. 4,050,777.
FOR PANTS; SHORTS; SPORT COATS (U.S. CLS. 22 AND 39).

KATHLEEN KOLACZ, EXAMINING ATTORNEY

SN 85-408,958. JIMI DRIGHT, JR., WOODLAND HILLS, CA. FILED 8-27-2011.

DIGITAL UNDERGROUND

THE MARK CONSISTS OF STANDARD CHARACTERS WITHOUT CLAIM TO ANY PARTICULAR FONT, STYLE, SIZE, OR COLOR.

FOR HATS; HOODED SWEATSHIRTS; JACKETS; T-SHIRTS; TANK TOPS (U.S. CLS. 22 AND 39).

JAMES MACFARLANE, EXAMINING ATTORNEY

SN 85-408,961. JIMI DRIGHT, JR., WOODLAND HILLS, CA. FILED 8-27-2011.



THE MARK CONSISTS OF A KEYBOARD WITH A TURNTABLE TO THE LEFT OF THE KEYBOARD, APPEARING UNDERNEATH THE WORDING "DIGITAL UNDERGROUND" IN A STYLIZED FONT WITH LOWERCASE LETTERS, WITH A COMPUTER WITH HEADPHONES APPEARING ON TOP OF THE MONITOR TO THE RIGHT OF THE WORD "DIGITAL", WITH JAGGED LINES REPRESENTING SOUND WAVES TO THE LEFT OF THE COMPUTER, AND WITH FOUR SETS OF EYES TO THE LEFT OF THE COMPUTER MONITOR AND ABOVE THE JAGGED SOUND WAVE LINES.

FOR HATS; HOODED SWEATSHIRTS; JACKETS; T-SHIRTS; TANK TOPS (U.S. CLS. 22 AND 39).

JAMES MACFARLANE, EXAMINING ATTORNEY

CLASS 25—(Continued).

SN 85-410,143. XIAMEN FIVE IMPORT AND EXPORT CO., LTD, XIAMEN, FUJIAN, CHINA, FILED 8-30-2011.



THE MARK CONSISTS OF THE STYLIZED WORDING "VGNODN" WITH THE "V" CONTAINING A CHEVRON WITHIN THE ANGLE OF THE LETTER. ABOVE THE WORDING IS A DESIGN CONSISTING OF AN INCOMPLETE SQUARE WITH A CHEVRON INSIDE OF IT. BELOW THE WORDING ARE THE CHINESE CHARACTERS WHICH TRANSLITERATE TO HUA GE LONG DENG.

THE WORDING "VGNODN" HAS NO MEANING IN A FOREIGN LANGUAGE.

THE NON-LATIN CHARACTERS IN THE MARK TRANSLITERATE TO "HUA GE LONG DENG" AND THIS HAS NO MEANING IN A FOREIGN LANGUAGE.

FOR BALLET SHOES; BALLROOM DANCING SHOES; BASEBALL SHOES; BEACH SHOES; BOAT SHOES; BOOTS; BOOTS FOR MOTORCYCLING; BOOTS FOR SPORT; BOWLING SHOES; BOXING SHOES; CLIMBING SHOES; DECK-SHOES; DRESSES; FOOTBALL BOOTS; FOOTBALL BOOTS AND STUDS THEREFOR; GLOVES; NECKTIES; POLYMER CUSTOM CUSHIONED SHOE INSERTS FOR PRIMARILY NON-ORTHOPEDIC PURPOSES; RIDING SHOES; SHOE PEGS; SHOE SOLES; SHOES; SKIING SHOES; SKULL CAPS; SOCKS; TAP SHOES; WOMEN'S SHOES; WORK SHOES AND BOOTS (U.S. CLS. 22 AND 39).

FIRST USE 8-5-2005; IN COMMERCE 8-21-2009.

MATTHEW MCDOWELL, EXAMINING ATTORNEY

SN 85-411,060. MERSHO, JOHN, SAN JOSE, CA. FILED 8-30-2011.

Cali Society

THE MARK CONSISTS OF STANDARD CHARACTERS WITHOUT CLAIM TO ANY PARTICULAR FONT, STYLE, SIZE, OR COLOR.

NO CLAIM IS MADE TO THE EXCLUSIVE RIGHT TO USE "CALI", APART FROM THE MARK AS SHOWN.

FOR HATS; JACKETS; SHOES; SHORTS; SOCKS; T-SHIRTS (U.S. CLS. 22 AND 39).

WILLIAM BRECKENFELD, EXAMINING ATTORNEY

CLASS 25—(Continued).

SN 85-414,937. SEITZ, NICHOLAS P., SYRACUSE, NY.
FILED 9-4-2011.

Yinzer

THE MARK CONSISTS OF STANDARD CHARACTERS WITHOUT CLAIM TO ANY PARTICULAR FONT, STYLE, SIZE, OR COLOR.

FOR SHORT-SLEEVED OR LONG-SLEEVED T-SHIRTS (U.S. CLS. 22 AND 39).

FIRST USE 11-8-2011; IN COMMERCE 11-8-2011.
SANI KHOURI, EXAMINING ATTORNEY

SN 85-416,076. LILA NIKOLE LLC, MIRAMAR, FL. FILED 9-6-2011.

LILA NIKOLE

COLLECTION

NO CLAIM IS MADE TO THE EXCLUSIVE RIGHT TO USE "COLLECTION", APART FROM THE MARK AS SHOWN.

THE NAME "LILA NIKOLE" IDENTIFIES A LIVING INDIVIDUAL WHOSE CONSENT IS OF RECORD.

THE MARK CONSIST OF THE STYLIZED WORDING "LILA NIKOLE COLLECTION".

FOR SWIMWEAR (U.S. CLS. 22 AND 39).
FIRST USE 7-14-2009; IN COMMERCE 7-14-2009.
LINDA M. KING, EXAMINING ATTORNEY

SN 85-418,788. S. SLATER & SON, INC., DBA GOLDEN BEAR SPORTSWEAR, SAN FRANCISCO, CA. FILED 9-9-2011.

GOLDEN BEAR

THE MARK CONSISTS OF STANDARD CHARACTERS WITHOUT CLAIM TO ANY PARTICULAR FONT, STYLE, SIZE, OR COLOR.

FOR LEATHER JACKETS; FLEECE AND LEATHER JACKETS; SUEDE JACKETS; WOOL, MELTON AND LEATHER VARSITY JACKETS; COMMEMORATIVE JACKETS AND AWARD JACKETS; AND LEATHER AND SUEDE VESTS AND SHIRTS (U.S. CLS. 22 AND 39).

FIRST USE 10-0-1943; IN COMMERCE 10-0-1943.
RUSS HERMAN, EXAMINING ATTORNEY

CLASS 25—(Continued).

SN 85-419,257. OSCAR MIKE LLC, POPLAR GROVE, IL.
FILED 9-9-2011.

OSCAR MIKE

THE MARK CONSISTS OF STANDARD CHARACTERS WITHOUT CLAIM TO ANY PARTICULAR FONT, STYLE, SIZE, OR COLOR.

THE NAME(S), PORTRAIT(S), AND/OR SIGNATURE(S) SHOWN IN THE MARK DOES NOT IDENTIFY A PARTICULAR LIVING INDIVIDUAL.

FOR CLOTHING, NAMELY, SHIRTS, T-SHIRTS, TOPS, JERSEYS, VESTS, SWEATERS, CAPS, BANDANAS, SHORTS, SWEAT SHIRTS, PANTS, BELTS, SOCKS, SWIMWEAR, JACKETS, RAINWEAR, FOOTWEAR, HATS, HEADBANDS, HEADWEAR, PAJAMAS, SLEEPWEAR AND UNDERGARMENTS (U.S. CLS. 22 AND 39).

FIRST USE 7-1-2006; IN COMMERCE 7-1-2006.
DAVID TOOLEY, EXAMINING ATTORNEY

SN 85-422,337. MARTINS, HAROLD, NEWTON, MA. FILED 9-14-2011.

LIFE IS HECTIC

THE MARK CONSISTS OF STANDARD CHARACTERS WITHOUT CLAIM TO ANY PARTICULAR FONT, STYLE, SIZE, OR COLOR.

FOR CLOTHING, NAMELY, SHIRTS, SWEATSHIRTS, JACKETS, SHORTS, PANTS, SWEATPANTS, HEADWEAR, FOOTWEAR (U.S. CLS. 22 AND 39).

MARIA-VICTORIA SUAREZ, EXAMINING ATTORNEY

CLASS 25—(Continued).

SN 85-422,429. FREMANTLEMEDIA LIMITED, LONDON, ENGLAND, FILED 9-14-2011.

TREE FU TOM

THE MARK CONSISTS OF STANDARD CHARACTERS WITHOUT CLAIM TO ANY PARTICULAR FONT, STYLE, SIZE, OR COLOR.

PRIORITY CLAIMED UNDER SEC. 44(D) ON ERPN CMNTY TM OFC APPLICATION NO. 009871443, FILED 4-6-2011, REG. NO. 009871443, DATED 8-22-2011, EXPIRES 4-6-2021.

FOR CLOTHING, NAMELY, SHIRTS, T-SHIRTS, PANTS, SHORTS, DRESSES, SKIRTS, BLOUSES, JACKETS, COATS, SWEATERS, SCARVES, GLOVES, UNDERWEAR, FOUNDATION GARMENTS, HOSIERY, NECKTIES, NIGHTWEAR, SWEAT BANDS, SWIMWEAR, LEOTARDS, LEG WARMERS, LAYETTES, APRONS, UNIFORMS, BOAS, HALLOWEEN COSTUMES, COSTUMES FOR USE IN ROLE-PLAYING GAMES, INFANTWEAR, RAINWEAR; FOOTWEAR INCLUDING BOOTS, SHOES, SLIPPERS, SANDALS, TRAINERS, SOCKS AND HOSIERY; HATS; CAPS; BERETS; SCARVES; GLOVES; MITTENS; ROBES; DRESSING GOWNS; PAJAMAS; SHORTS; SLEEPSUITS; UNDERWEAR; BELTS BEING ARTICLES OF CLOTHING (U.S. CLS. 22 AND 39).

MARK RADEMACHER, EXAMINING ATTORNEY

SN 85-422,732. RAYFIELD, MIRIAM, FORT WASHINGTON, MD. FILED 9-14-2011.

CHARAY'S E.I.J.N.
(EVERYTHING IN JESUS NAME)

THE MARK CONSISTS OF STANDARD CHARACTERS WITHOUT CLAIM TO ANY PARTICULAR FONT, STYLE, SIZE, OR COLOR.

FOR CLOTHING, NAMELY, TOPS, BOTTOMS, SKIRTS, SHORTS, SWEATSHIRTS, JACKETS, ROBES, COATS, PAJAMAS, SLIPPERS, HATS, WRIST BANDS, HEAD BANDS, SOCKS, SCARVES; BABY WEAR, NAMELY, CLOTH BIBS AND ONE PIECE GARMENTS; AND NECKWEAR (U.S. CLS. 22 AND 39).

REGINA DRUMMOND, EXAMINING ATTORNEY

CLASS 25—(Continued).

SN 85-424,627. CHAPTER 4 CORP., DBA SUPREME, NEW YORK, NY. FILED 9-16-2011.

SUPREME

THE MARK CONSISTS OF STANDARD CHARACTERS WITHOUT CLAIM TO ANY PARTICULAR FONT, STYLE, SIZE, OR COLOR.

FOR CLOTHING, NAMELY, SHIRTS, T-SHIRTS, LONG-SLEEVED SHIRTS, UNDER SHIRTS, POLO SHIRTS, RUGBY SHIRTS, JERSEYS, DRESS SHIRTS, DENIM JEANS, HOODED SWEAT SHIRTS, WARM-UP SUITS, SNOW SUITS, PARKAS, CARDIGANS, PANTS, JEAN JACKETS, CARGO PANTS, SHORTS, BOXER SHORTS, TOPS, TANK TOPS, SWEAT SHIRTS, SWEAT JACKETS, SWEAT SHORTS, SWEAT PANTS, SWEATERS, VESTS, FLEECE VESTS, PULLOVERS, JACKETS, COATS, BLAZERS, SUITS, TURTLENECKS, REVERSIBLE JACKETS, WIND-RESISTANT JACKETS, SHELL JACKETS, SPORTS JACKETS, GOLF AND SKI JACKETS, HEAVY COATS, OVER COATS, TOP COATS, SWIMWEAR, BEACHWEAR, VISORS, HEADBANDS, EAR MUFFS, THERMAL UNDERWEAR, LONG UNDERWEAR, UNDERCLOTHES, CAPS, HATS, KNIT CAPS, HEADWEAR, SCARVES, BANDANAS, BELTS, NECKWEAR, TIES, ROBES, GLOVES, BOOTS, RAINWEAR, FOOTWEAR, SHOES AND SNEAKERS (U.S. CLS. 22 AND 39).

FIRST USE 4-0-1994; IN COMMERCE 4-0-1994.
STEVEN JACKSON, EXAMINING ATTORNEY

SN 85-425,329. CHRISTINA GOERNER, AKA CHRISTINA GERNER, ANNAPOLIS, MD. FILED 9-17-2011.

Christina Gerner

THE MARK CONSISTS OF STANDARD CHARACTERS WITHOUT CLAIM TO ANY PARTICULAR FONT, STYLE, SIZE, OR COLOR.

THE NAME "CHRISTINA GERNER" IDENTIFIES A LIVING INDIVIDUAL WHOSE CONSENT IS OF RECORD.

FOR SPORTS AND READY WEAR, NAMELY, SUITS, SLACKS, TROUSERS, SHORTS, JACKETS, BLAZERS, DRESS SHIRTS, KNIT SHIRTS, SWEATERS, BLOUSES, SKIRTS, COATS AND DRESSES, BELTS, GLOVES, HATS, SCARVES, EVENING WEAR, NAMELY, GOWNS, SHORT DRESSES, PANTS AND TUNICS, CAPS, UNDERGARMENTS, SLEEPWEAR, AND LOUNGEWEAR, AND ALL PURPOSE FOOTWEAR EXCLUDING ORTHOPEDIC FOOTWEAR (U.S. CLS. 22 AND 39).

BRENDAN MCCAULEY, EXAMINING ATTORNEY

CLASS 25—(Continued).

SN 85-425,399. DANIELS, APRIL, NEW YORK, NY. AND MOORE, MARQUITA, NEW YORK, NY. FILED 9-17-2011.



THE NAME(S), PORTRAIT(S), AND/OR SIGNATURE(S) SHOWN IN THE MARK DOES NOT IDENTIFY A PARTICULAR LIVING INDIVIDUAL.

THE MARK CONSISTS OF THE WORDS, "RIVER & JETT" IN MIXED UPPERCASE AND LOWERCASE LETTERS. THE WORDS, "KID OF HONOR" IN ALL UPPERCASE LETTERS IS CENTERED IMMEDIATELY BELOW THE WORDS, "RIVER & JETT". THERE IS A FLAG WAVING ON A POLE IMMEDIATELY BELOW THE WORDS, "KID OF HONOR".

FOR BELTS; BELTS FOR CLOTHING; CAPRI PANTS; CARGO PANTS; CHILDREN'S AND INFANT'S APPAREL, NAMELY, JUMPERS, OVERALL SLEEPWEAR, PAJAMAS, ROMPERS AND ONE-PIECE GARMENTS; CHILDREN'S HEADWEAR; COLLARED SHIRTS; CREW NECK SWEATERS; DENIMS; DRESS SHIRTS; GOLF PANTS, SHIRTS AND SKIRTS; GOLF SHIRTS; HOODED SWEAT SHIRTS; HOODED SWEATSHIRTS FOR CHILDREN; HOODS; JACKETS; JEANS; JEGGINGS, NAMELY, PANTS THAT ARE PARTIALLY JEANS AND PARTIALLY LEGGINGS; JERSEYS; JOGGING PANTS; KNIT SHIRTS; LEATHER BELTS; LEATHER PANTS; LONG-SLEEVED SHIRTS; LOUNGE PANTS; MOCK TURTLE-NECK SWEATERS; PANTS; POLO SHIRTS; RUGBY SHIRTS; SHIRTS; SHIRTS AND SHORT-SLEEVED SHIRTS; SHIRTS FOR INFANTS, BABIES, TODDLERS AND CHILDREN; SHORT-SLEEVED OR LONG-SLEEVED T-SHIRTS; SHORT-SLEEVED SHIRTS; SLEEP PANTS; SLEEP SHIRTS; SPORT SHIRTS; SPORTS SHIRTS; SPORTS SHIRTS WITH SHORT SLEEVES; STRETCH PANTS; SWEAT PANTS; SWEAT SHIRTS; SWEATERS; SWEATSHIRTS FOR CHILDREN; T-SHIRTS; T-SHIRTS FOR CHILDREN; TRACK PANTS; TURTLE NECK SHIRTS; TURTLENECK SWEATERS; V-NECK SWEATERS; WEARABLE GARMENTS AND CLOTHING, NAMELY, SHIRTS (U.S. CLS. 22 AND 39).
REBECCA SMITH, EXAMINING ATTORNEY

SN 85-425,419. KHUSH, HONOLULU, HI. FILED 9-17-2011.



THE MARK CONSISTS OF THE WORD "KHUSH" IN STYLIZED FONT AND A CAPITALIZED LETTER "K"

THE ENGLISH TRANSLATION OF "KHUSH" IS "HAPPY, GLAD, PLEASED"

FOR WOMEN'S CLOTHING, NAMELY, DRESSES, TOPS, SHIRTS, PANTS, SHORT, SKIRTS, JUMPSUITS, COVERUPS (U.S. CLS. 22 AND 39).

FIRST USE 6-25-2002; IN COMMERCE 6-25-2002.
ANDREA BUTLER, EXAMINING ATTORNEY

CLASS 25—(Continued).

SN 85-426,448. LINDSAY, JAMES J., DBA ZONE WEAR, CARLSBAD, CA. FILED 9-19-2011.



THE MARK CONSISTS OF STANDARD CHARACTERS WITHOUT CLAIM TO ANY PARTICULAR FONT, STYLE, SIZE, OR COLOR.

FOR CLOTHING, NAMELY, T-SHIRTS, GOLF SHIRTS, AND HATS (U.S. CLS. 22 AND 39).

FIRST USE 3-25-2000; IN COMMERCE 8-4-2000.
ALLISON HOLTZ, EXAMINING ATTORNEY

SN 85-428,469. STAR OF INDIA FASHIONS INC, TEMPE, AZ. FILED 9-21-2011.



THE COLOR(S) IVORY, BLACK AND WHITE IS/ARE CLAIMED AS A FEATURE OF THE MARK.

THE MARK CONSISTS OF AN IVORY BACKGROUND WITH THE WORD "SMITH." IN BLACK WRITTEN AT THE BOTTOM OF THE FRAME IN A TYPE-WRITER FONT WITH THE LETTER "I" SLIGHTLY BOLDER THAN THE OTHER LETTERS IN "SMITH.". A BLACK AND WHITE FLORAL OR LACE IMAGE APPEARS AT THE TOP OF THE MARK.

FOR WOMEN'S CLOTHING, NAMELY, SHIRTS, DRESSES, SKIRTS, BLOUSES (U.S. CLS. 22 AND 39).

FIRST USE 0-0-2008; IN COMMERCE 0-0-2008.
CAROLINE WOOD, EXAMINING ATTORNEY

SN 85-428,549. WILHELM, NEW YORK, NY. FILED 9-21-2011.



THE MARK CONSISTS OF STANDARD CHARACTERS WITHOUT CLAIM TO ANY PARTICULAR FONT, STYLE, SIZE, OR COLOR.

FOR CLOTHING, NAMELY, FEATHER SCARVES, FEATHER CAPELETS (U.S. CLS. 22 AND 39).

BRIDGETT SMITH, EXAMINING ATTORNEY

CLASS 25—(Continued).

SN 85-429,108. OLA NATION LLC, WEST COVINA, CA. FILED 9-22-2011.

On Top U.S.A.

THE MARK CONSISTS OF STANDARD CHARACTERS WITHOUT CLAIM TO ANY PARTICULAR FONT, STYLE, SIZE, OR COLOR.

NO CLAIM IS MADE TO THE EXCLUSIVE RIGHT TO USE "U.S.A.", APART FROM THE MARK AS SHOWN.

FOR SHIRTS; T-SHIRTS; TOPS (U.S. CLS. 22 AND 39).

FIRST USE 2-8-2010; IN COMMERCE 4-8-2010.

SCOTT BIBB, EXAMINING ATTORNEY

CLASS 25—(Continued).

SN 85-432,742. LITTERIO, MICHAEL, ABINGTON, MA. FILED 9-27-2011.



SN 85-429,297. BYER CALIFORNIA, SAN FRANCISCO, CA. FILED 9-22-2011.

ALYX LIMITED

THE MARK CONSISTS OF STANDARD CHARACTERS WITHOUT CLAIM TO ANY PARTICULAR FONT, STYLE, SIZE, OR COLOR.

OWNER OF U.S. REG. NO. 3,188,178.

NO CLAIM IS MADE TO THE EXCLUSIVE RIGHT TO USE "LIMITED", APART FROM THE MARK AS SHOWN.

FOR CLOTHING, NAMELY, DRESSES, SKIRTS, BLOUSES, SKORTS, SHORTS, SHIRTS, PANTS, JACKETS, SWEATERS, VESTS AND JUMPSUITS (U.S. CLS. 22 AND 39).

KATHLEEN KOLACZ, EXAMINING ATTORNEY

SN 85-431,448. ONE, TIST, DBA LOVELABRAND, LOS ANGELES, CA. FILED 9-26-2011.



NO CLAIM IS MADE TO THE EXCLUSIVE RIGHT TO USE "LA", APART FROM THE MARK AS SHOWN.

THE MARK CONSISTS OF ATHLETIC FONT CAPITAL LETTERS "L" AND "A" FOR LOS ANGELES ARE PLACED AS THE EYES OF A SMILING FACED HEART.

FOR ATHLETIC APPAREL, NAMELY, SHIRTS, PANTS, JACKETS, FOOTWEAR, HATS AND CAPS, ATHLETIC UNIFORMS (U.S. CLS. 22 AND 39).

FIRST USE 7-1-2011; IN COMMERCE 7-1-2011.

TRACY CROSS, EXAMINING ATTORNEY

NO CLAIM IS MADE TO THE EXCLUSIVE RIGHT TO USE "BOSTON", APART FROM THE MARK AS SHOWN.

THE COLOR(S) BLUE, RED, WHITE, BROWN, BLACK, LIGHT BROWN, REDDISH BROWN AND ORANGE IS/ARE CLAIMED AS A FEATURE OF THE MARK.

THE MARK CONSISTS OF "BOSTON'S ALL" IN BLUE STYLIZED LETTERS WITH SPORTS EQUIPMENT WITHIN THE LETTERS FOR "BOSTON"; THE BASKETBALL IN THE "B" IS ORANGE WITH BLACK LINING AND THE BASEBALL IS WHITE WITH RED LINING; THE FOOTBALL IN THE "O" IS REDDISH BROWN WITH WHITE LINING; THE HOCKEY STICK IN THE "S" IS WHITE WITH RED LINING ON THE TOP; THE BASEBALL BAT IN THE "T" IS LIGHT BROWN ON THE TOP AND BROWN ON THE BOTTOM; THE FOOTBALL IN THE "O" IS REDDISH BROWN WITH WHITE LINING; THE BASEBALL BAT IN THE "N" IS BROWN ON THE BOTTOM AND LIGHT BROWN ON THE TOP AND THE HOCKEY STICK IN THE "S" IS WHITE WITH RED LINING ON THE TOP. THE RED HEART IS OUTLINED IN BLUE WITH AN ORANGE BASKETBALL WITH WHITE SHADING AND BLACK LINING, A WHITE BASEBALL WITH RED LINING, A BLACK HOCKEY PUCK, A REDDISH BROWN FOOTBALL WITH WHITE LINING, A WHITE BASKETBALL NET WITH A RED HOOP, A WHITE FOOTBALL GOAL, AND A WHITE HOCKEY GOAL.

FOR HATS; JACKETS; PANTS; SHIRTS; SHORTS; SWEATSHIRTS (U.S. CLS. 22 AND 39).

MICHELE SWAIN, EXAMINING ATTORNEY

CLASS 25—(Continued).

SN 85-433,567. DAVON BEAN, NEW YORK, NY. FILED 9-27-2011.



OWNER OF U.S. REG. NOS. 4,037,761 AND 4,071,678.
THE MARK CONSISTS OF AN "F" AND A SHADED "G" SHAPED LIGHT BULB WITH "FLY GEENIUS" LETTERING WRITTEN ON THE BOTTOM.
FOR HATS; SWEATSHIRTS; T-SHIRTS (U.S. CLS. 22 AND 39).
FIRST USE 1-1-2011; IN COMMERCE 4-7-2011.
VIVIAN MICZNIK FIRST, EXAMINING ATTORNEY

SN 85-435,675. ALL THE ABOVE CLOTHING, INC., DENVER, CO. FILED 9-29-2011.

ALL THE ABOVE CLOTHING

THE MARK CONSISTS OF STANDARD CHARACTERS WITHOUT CLAIM TO ANY PARTICULAR FONT, STYLE, SIZE, OR COLOR.
NO CLAIM IS MADE TO THE EXCLUSIVE RIGHT TO USE "CLOTHING", APART FROM THE MARK AS SHOWN.
FOR CLOTHING, NAMELY, T-SHIRTS; SWEATSHIRTS; JACKETS; TANK TOPS (U.S. CLS. 22 AND 39).
FIRST USE 10-23-2010; IN COMMERCE 10-23-2010.
MARK T. MULLEN, EXAMINING ATTORNEY

CLASS 25—(Continued).

SN 85-436,099. LEAVITT, ALLYSON I., BETHPAGE, NY. FILED 9-30-2011.

ALLYSON IVY

THE MARK CONSISTS OF STANDARD CHARACTERS WITHOUT CLAIM TO ANY PARTICULAR FONT, STYLE, SIZE, OR COLOR.

THE NAME(S), PORTRAIT(S), AND/OR SIGNATURE(S) SHOWN IN THE MARK IDENTIFIES ALLYSON IVY LEAVITT, WHOSE CONSENT(S) TO REGISTER IS MADE OF RECORD.

FOR CLOTHING, NAMELY, BOTTOMS, JEANS, SKIRTS, DRESSES, SHIRTS, BLOUSES, AND JACKETS, FOR MEN AND WOMEN (U.S. CLS. 22 AND 39).

ANDREA HACK, EXAMINING ATTORNEY

SN 85-437,071. VINTAGE HIGHWAY, LLC, CLAYTON, MO. FILED 9-30-2011.

Vintage Highway

THE MARK CONSISTS OF STANDARD CHARACTERS WITHOUT CLAIM TO ANY PARTICULAR FONT, STYLE, SIZE, OR COLOR.

NO CLAIM IS MADE TO THE EXCLUSIVE RIGHT TO USE "VINTAGE", APART FROM THE MARK AS SHOWN.

FOR T-SHIRTS, DOLMANS, THERMAL T-SHIRTS, TANK TOPS, DRESSES, SCARVES, SWEATSHIRTS, LONG SLEEVE T-SHIRTS, SHORT-SLEEVE T-SHIRTS (U.S. CLS. 22 AND 39).

FIRST USE 5-0-2010; IN COMMERCE 5-0-2010.
DAVID MURRAY, EXAMINING ATTORNEY

SN 85-438,266. ENDO CUSTOMS, INC., CULVER CITY, CA. FILED 10-3-2011.



NO CLAIM IS MADE TO THE EXCLUSIVE RIGHT TO USE "CUSTOMS", APART FROM THE MARK AS SHOWN.
THE MARK CONSISTS OF THE LETTER "C" WITH A LIGHTNING BOLT STARTING FROM OUTSIDE THE LEFT EDGE OF THE LETTER "C" AND CONTINUING

CLASS 25—(Continued).

THROUGH AND FOR A DISTANCE OF APPROXIMATELY TWICE THE LENGTH OF THE LETTER "C" BEYOND THE LEFT OPEN SIDE OF THE "C". IN ADDITION, THE LEFT UPPER CURVE OF THE "C" ABOVE THE LIGHTNING BOLT, IS EXTENDED ON A 45 DEGREE ANGLE TO CONNECT TO THE TOP AND LEFT EDGE OF THE LIGHTNING BOLT AT THE CLOSED END OF THE "C", AND THE LOWER END OF THE "C" AT THE OPEN END IS TAPERED SO THAT IT IS PARALLEL WITH THE ANGLED BOLT AS IT LEAVES THE OPEN END OF THE "C". BELOW THIS GRAPHIC IMAGE DESCRIBED ABOVE THE WORD "ENDO" APPEARS IN ALL CAPS, AND BELOW "ENDO" THE WORD "CUSTOMS" APPEARS ALL CAPS. THE WORD "CUSTOMS" IS IN MUCH SMALLER LETTERS THAN "ENDO" AS IT APPEARS DIRECTLY BELOW "ENDO" BUT HAS THE SAME LEFT AND RIGHT MARGINS.

FOR BASEBALL CAPS; CAPS; CAPS WITH VISORS; CLOTHING FOR ATHLETIC USE, NAMELY, PADDED ELBOW COMPRESSION SLEEVES BEING PART OF AN ATHLETIC GARMENT; CLOTHING FOR ATHLETIC USE, NAMELY, PADDED PANTS; CLOTHING FOR ATHLETIC USE, NAMELY, PADDED SHIRTS; CLOTHING FOR ATHLETIC USE, NAMELY, PADDED SHORTS; CLOTHING, NAMELY, ATHLETIC SLEEVES; CLOTHING, NAMELY, BASE LAYERS; GLOVES AS CLOTHING; HEADBANDS FOR CLOTHING; HOODED SWEATSHIRTS; JACKETS; JERSEYS; KNITTED CAPS; SHORT-SLEEVED OR LONG-SLEEVED T-SHIRTS; SPORTS CAPS AND HATS; SWEATSHIRTS; TRIATHLON CLOTHING, NAMELY, TRIATHLON TIGHTS, TRIATHLON SHORTS, TRIATHLON SINGLETTS, TRIATHLON SHIRTS, TRIATHLON SUITS; WEARABLE GARMENTS AND CLOTHING, NAMELY, SHIRTS; WOMEN'S CLOTHING, NAMELY, SHIRTS, DRESSES, SKIRTS, BLOUSES (U.S. CLS. 22 AND 39).

JUSTINE D. PARKER, EXAMINING ATTORNEY

SN 85-438,553. WINGMAN LLC, DBA WINGMAN APPAREL COMPANY, CLARKSVILLE, TN. FILED 10-4-2011.



NO CLAIM IS MADE TO THE EXCLUSIVE RIGHT TO USE "APPAREL COMPANY", APART FROM THE MARK AS SHOWN.

THE MARK CONSISTS OF THE WORD, "WINGMAN" ABOVE A ROUNDED SQUARE BOX CONTAINING AN OFF-CENTERED "W" POSITIONED WITHIN AN INCOMPLETE CIRCLE. THE BOX IS CENTERED BELOW THE WORD "WINGMAN". TO THE LEFT OF THE BOX IS THE WORD "APPAREL". TO THE RIGHT OF THE BOX IS THE WORD "COMPANY".

FOR HATS; HOODED SWEATSHIRTS; SHORT-SLEEVED OR LONG-SLEEVED T-SHIRTS; SWEATSHIRTS (U.S. CLS. 22 AND 39).

FIRST USE 7-25-2010; IN COMMERCE 7-25-2010.

KAREN BRACEY, EXAMINING ATTORNEY

CLASS 25—(Continued).

SN 85-439,296. JAYSON CROSS, NEW YORK, NY. FILED 10-4-2011.

Cougars The Only Cats I'm Not Allergic To

THE MARK CONSISTS OF STANDARD CHARACTERS WITHOUT CLAIM TO ANY PARTICULAR FONT, STYLE, SIZE, OR COLOR.

FOR T-SHIRTS (U.S. CLS. 22 AND 39).

FIRST USE 9-15-2011; IN COMMERCE 9-15-2011.

JOHN E. MICHS, EXAMINING ATTORNEY

SN 85-439,725. 2253 APPAREL INC., DBA CELEBRITY PINK INC., MONTEBELLO, CA. FILED 10-5-2011.

SILENT DISCO

THE MARK CONSISTS OF STANDARD CHARACTERS WITHOUT CLAIM TO ANY PARTICULAR FONT, STYLE, SIZE, OR COLOR.

FOR DENIMS, PANTS, TOPS, JACKETS, SHIRTS, SKIRTS, T-SHIRTS, DRESSES, HATS, CAPS, JEANS, BLOUSES, OVERALLS, SHOES, UNDERGARMENTS, SHORTS (U.S. CLS. 22 AND 39).

KATHLEEN LORENZO, EXAMINING ATTORNEY

SN 85-441,894. AGAO, JENNIFER, LAS VEGAS, NV. FILED 10-7-2011.



THE MARK CONSISTS OF THE STYLIZED TEXT "SOUL SEXUAL" INSIDE OF TWO HORIZONTAL RECTANGLES. THE LETTER "O" IN SOUL IS REPLACED WITH A HEART.

FOR T-SHIRTS (U.S. CLS. 22 AND 39).

DAVID COLLIER, EXAMINING ATTORNEY

CLASS 25—(Continued).

SN 85-442,060. PEI-CHIA YAO, TAICHUNG CITY, TAIWAN, FILED 10-7-2011.



THE MARK CONSISTS OF STYLIZED WORDING "RUTER" ON THE RIGHT AND A DEVICE ON THE LEFT. THE DEVICE IS PROVIDED AT THE RIGHT THEREOF WITH A PARALLELOGRAM FORMED BY PARALLEL LINES INCLINED LEFTWARD WITH DIFFERENT WIDTH, AND AT THE LEFT WITH A TRAPEZOID FORMED BY PARALLEL LINES INCLINED RIGHTWARD WITH DIFFERENT WIDTH AND LENGTH AND EXTENDING TO THE LEFT SIDE OF THE PARALLELOGRAM IN SUCH A WAY THAT A TRIANGLE BLACK IS LEFT AT THE BOTTOM CENTER OF THE DEVICES.

FOR FOOTWEAR, SHOES, ATHLETIC SHOES, BEACH SHOES, LEATHER SHOES, LEISURE SHOES, RUNNING SHOES, MOUNTAINEERING BOOTS, SKI BOOTS, BOOTS, SANDALS, SLIPPERS, FOOTWEAR UPPERS, SOLES FOR FOOTWEAR, INSOLES FOR FOOTWEAR, HEELS; CLOTHING, NAMELY, SHIRTS, T-SHIRTS, SWEATSHIRTS, BLOUSES, JACKETS, COATS, PANTS, SHORTS, SWEATPANTS; HEADWEAR; GLOVES, SOCKS, BELTS, SCARVES, TIES (U.S. CLS. 22 AND 39).
EMILY CARLSEN, EXAMINING ATTORNEY

SN 85-442,616. VONRABENAU, SEAN, ORLANDO, FL. FILED 10-7-2011.

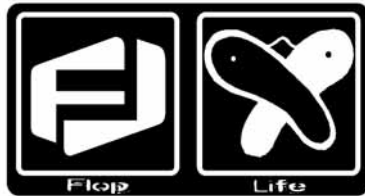

THE MARK CONSISTS OF TWO SQUARES WITHIN A LARGER RECTANGLE. THE 1ST SQUARE CONTAINS A STYLIZED FONT WITH A FORWARD FACING "F" AND BACKWARD FACING "L". THE LETTERS MAKE A HEXAGON SHAPE. THE 2ND SQUARE HAS CROSSED SANDALS OR FLIP-FLOPS IN THE MIDDLE WITH SUNGLASSES ABOVE THE SANDALS. THE TEXT "FLOP LIFE" APPEARS BELOW.

FOR CLOTHING, NAMELY, FLIP FLOPS, SANDALS, WRISTBANDS, SWEATBANDS, VISORS, CAPS, T-SHIRTS, SWEATSHIRTS, SHORTS, DRESSES, SHIRTS, POLO SHIRTS, RUNNING SHORTS, CLOTH BIBS, AND RASH GUARDS (U.S. CLS. 22 AND 39).
DAVID TOOLEY, EXAMINING ATTORNEY

CLASS 25—(Continued).

SN 85-442,676. MCKNIGHT, ZURIAH, RIVERSIDE, CA. FILED 10-7-2011.



NO CLAIM IS MADE TO THE EXCLUSIVE RIGHT TO USE "CLOTHING", APART FROM THE MARK AS SHOWN. THE MARK CONSISTS OF A CLOCK WITH THE HANDS ON THE "9" AND "5", A BIG NUMBER "2" IN THE CENTER OF THE CLOCK, AND THE TEXT "NINE TO FIVE CLOTHING" BELOW THE CLOCK.

FOR DRESSES; JEANS; SHIRTS; SHORTS; SWIM SUITS; TANK TOPS (U.S. CLS. 22 AND 39).
ROBIN MITTLER, EXAMINING ATTORNEY

SN 85-442,895. POUYA TORABI, DANA POINT, CA. FILED 10-9-2011.

Weirdo 4 Life

THE MARK CONSISTS OF STANDARD CHARACTERS WITHOUT CLAIM TO ANY PARTICULAR FONT, STYLE, SIZE, OR COLOR.

OWNER OF U.S. REG. NO. 4,067,938.
FOR ATHLETIC APPAREL, NAMELY, SHIRTS, PANTS, JACKETS, FOOTWEAR, HATS AND CAPS, ATHLETIC UNIFORMS; BASEBALL CAPS; CAPRI PANTS; CAPS; CARGO PANTS; CREW NECK SWEATERS; DOWN JACKETS; GYM PANTS; HATS; HEAVY JACKETS; JACKETS; JACKETS AND SOCKS; JOGGING PANTS; KNITTED CAPS; KNOT CAPS; KNOTTED CAPS; LEATHER JACKETS; LONG JACKETS; LONG SLEEVE PULLOVERS; LONG SLEEVED VESTS; LONG UNDERWEAR; LONG-SLEEVED SHIRTS; MEN'S AND WOMEN'S JACKETS, COATS, TROUSERS, VESTS; MOTORCYCLE JACKETS; PANTS; SHIRTS AND SHORT-SLEEVED SHIRTS; SHORT-SLEEVED OR LONG-SLEEVED T-SHIRTS; SHORT-SLEEVED SHIRTS; SKI JACKETS; SKULL CAPS; SLEEVED OR SLEEVELESS JACKETS; SNOW PANTS; SNOWBOARD PANTS; SPORTS PANTS; SPORTS SHIRTS WITH SHORT SLEEVES; STRETCH PANTS; SWEAT JACKETS; SWEAT PANTS; SWEATERS; T-SHIRTS; TRACK JACKETS; TRACK PANTS; TURTLENECK SWEATERS; V-NECK SWEATERS; WARM UP OUTFITS; WARM UP SUITS; WATERPROOF JACKETS AND PANTS; WIND RESISTANT JACKETS; WIND-JACKETS (U.S. CLS. 22 AND 39).
JAY BESCH, EXAMINING ATTORNEY

CLASS 25—(Continued).

SN 85-443,644. HERNANDO CABÁN-MÉNDEZ, DBA CHRONIC SPORTSWEAR, AUSTIN, TX. FILED 10-10-2011.

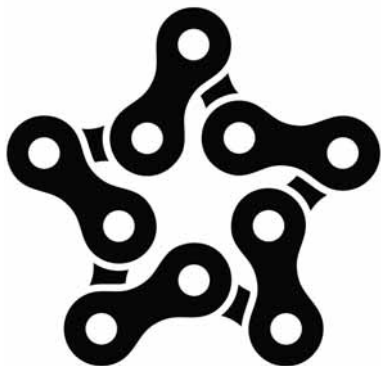

THE MARK CONSISTS OF BICYCLE CHAIN LINKS FORMING A FIVE-POINT STAR.

FOR ATHLETIC APPAREL, NAMELY, SHIRTS, PANTS, JACKETS, FOOTWEAR, HATS AND CAPS, ATHLETIC UNIFORMS; ATHLETIC TIGHTS; ATHLETIC UNIFORMS; BIB SHORTS; BIB TIGHTS; BODY SHIRTS; CLOTHING FOR ATHLETIC USE, NAMELY, PADDED PANTS; COMPRESSION GARMENTS FOR ATHLETIC OR OTHER NON-MEDICAL USE, NAMELY, JERSEYS AND SHORTS; CYCLING SHORTS; CYCLISTS' JERSEYS; JERSEYS; LONG-SLEEVED SHIRTS; MOISTURE-WICKING SPORTS PANTS; MOISTURE-WICKING SPORTS SHIRTS; SHORT-SLEEVED OR LONG-SLEEVED T-SHIRTS; SHORT-SLEEVED SHIRTS; SLEEVELESS JERSEYS; SPORT SHIRTS; SPORT STOCKINGS; SPORTS JERSEYS; SPORTS PANTS; SPORTS SHIRTS; SPORTS SHIRTS WITH SHORT SLEEVES; T-SHIRTS; TEE SHIRTS; TRIATHLON CLOTHING, NAMELY, TRIATHLON TIGHTS, TRIATHLON SHORTS, TRIATHLON SINGLET, TRIATHLON SHIRTS, TRIATHLON SUITS (U.S. CLS. 22 AND 39).

FIRST USE 10-0-2008; IN COMMERCE 0-0-2009.
ELLEN PERKINS, EXAMINING ATTORNEY

SN 85-443,919. U.S. PILOT LLC, HURRICANE, WV. FILED 10-11-2011.



NO CLAIM IS MADE TO THE EXCLUSIVE RIGHT TO USE "U.S.", APART FROM THE MARK AS SHOWN.

THE COLOR(S) BLUE, RED, WHITE AND BLACK IS/ARE CLAIMED AS A FEATURE OF THE MARK.

THE MARK CONSISTS OF THE LITERAL ELEMENT "U.S. PILOT" WRITTEN IN BLACK COLOR OVER AN AMERICAN STYLE FLAG WITH 4 RED AND 3 WHITE STRIPES AND A STAR IN WHITE COLOR INSIDE A BOX IN BLUE COLOR WITH THE ENTIRE FLAG DESIGN BEING OUTLINED IN BLACK.

FOR CLOTHING, NAMELY, T-SHIRTS, POLO SHIRTS, BUTTON UP SHIRTS, HATS, JACKETS, COATS, PANTS (U.S. CLS. 22 AND 39).

MEGHAN REINHART, EXAMINING ATTORNEY

CLASS 25—(Continued).

SN 85-444,547. SALVATION, LLC, TUCSON, AZ. FILED 10-11-2011.

J. CHRISTIANMAN

THE MARK CONSISTS OF STANDARD CHARACTERS WITHOUT CLAIM TO ANY PARTICULAR FONT, STYLE, SIZE, OR COLOR.

OWNER OF U.S. REG. NOS. 3,946,463 AND 4,091,660.

THE NAME "J. CHRISTIANMAN" DOES NOT IDENTIFY A LIVING INDIVIDUAL.

FOR CLOTHING, NAMELY, BELTS, BOARD SHORTS, CAPS, COLLARED SHIRTS, HATS, HOODED SWEATSHIRTS, JACKETS, JEANS, KNIT SHIRTS, SHOES, SHORTS, SOCKS, SWEATERS, SWIMMING TRUNKS AND TEE SHIRTS (U.S. CLS. 22 AND 39).

ELLEN BURNS, EXAMINING ATTORNEY

SN 85-444,700. GOMEZ ZAPATA S.A., BOGOTA D.C., COLOMBIA, FILED 10-11-2011.



NO CLAIM IS MADE TO THE EXCLUSIVE RIGHT TO USE "JEANS", APART FROM THE MARK AS SHOWN.

THE MARK CONSISTS OF THE LETTERS "ATM" IN BIG, PROMINENT STYLIZED LETTERS. BELOW THE LETTER "M" APPEARS THE WORD "JEANS" IN CURSIVE FORM. BEHIND THE LETTERS "ATM" APPEARS AN OVAL SHAPED RING INCREASING ITS SIZE GRADUALLY FROM THE BOTTOM RIGHT SIDE TO THE LEFT SIDE, DECREASING AGAIN ITS SIZE AS IT MEETS THE RIGHT SIDE AND CLOSES.

FOR CAPS; DRESSES; FOOTWEAR FOR MEN AND WOMEN; HEAD WEAR; JACKETS; JEANS; LINGERIE; SHIRTS; SKIRTS; SUITS; TROUSERS (U.S. CLS. 22 AND 39).

JENNIFER VASQUEZ, EXAMINING ATTORNEY

SN 85-445,303. BILLY DEE GLOVER SR., DBA GO TO HELL IN 2012.COM, CHICAGO, IL. FILED 10-12-2011.

GO TO HELL IN 2012.COM

THE MARK CONSISTS OF STANDARD CHARACTERS WITHOUT CLAIM TO ANY PARTICULAR FONT, STYLE, SIZE, OR COLOR.

FOR ATHLETIC APPAREL, NAMELY, SHIRTS, PANTS, JACKETS, FOOTWEAR, HATS AND CAPS, ATHLETIC UNIFORMS (U.S. CLS. 22 AND 39).

MICHAEL KEATING, EXAMINING ATTORNEY

CLASS 25—(Continued).

SN 85-445,331. SKIN HOLDINGS, LLC, NEW YORK, NY. FILED 10-12-2011.



OWNER OF U.S. REG. NOS. 3,543,666 AND 3,782,765. THE MARK CONSISTS OF THE WORD "SKIN" APPEARING IN LOWER-CASE IN A STYLIZED MANNER. FOR MEN'SWEAR, NAMELY, OVERCOATS, SWEAT SHIRTS, JACKETS, SWEATERS, SHIRTS, T-SHIRTS, POLO SHIRTS, RUGBY SHIRTS, LONG-SLEEVED SHIRTS, SHORTS, SOCKS, TRACK PANTS, SWEAT PANTS, UNDERWEAR, SWIMWEAR, SUITS, BLAZERS, COATS, PANTS, TROUSERS, VESTS AND NECKTIES; FOOTWEAR; ACCESSORIES, NAMELY, SCARVES, GLOVES, HATS AND BELTS (U.S. CLS. 22 AND 39). CAROLINE WOOD, EXAMINING ATTORNEY

SN 85-445,372. CHRISSTYLES, LLC, ATLANTA, GA. FILED 10-12-2011.



THE COLOR(S) GREEN, BLACK, GREY, RED, ORANGE AND WHITE IS/ARE CLAIMED AS A FEATURE OF THE MARK. THE MARK CONSISTS OF A BLACK CIRCLE WITH THE WORD "DANK" IN GREEN LETTERS OUTLINED IN BLACK, THE WORD "DANK" BEING WITHIN THE CIRCLE AND EXTENDING ALONG AN ARC GENERALLY CONCENTRIC WITH, AND SUBSTANTIALLY ALONG, THE UPPER HALF OF THE CIRCLE. THE LETTER "N" OF "DANK" HAS WHITE PORTIONS ON THE LEADING EDGE OF THE LETTER AND ON THE LEADING EDGE OF THE LOWER ANGLED PORTION OF THE LETTER AND THE LETTER "K" HAS WHITE PORTIONS ON ITS LEADING EDGE, ON THE LEADING EDGE OF THE LOWER LEG OF THE ANGLED PORTION OF THE LETTER "K", AND ON THE LEADING EDGE OF BOTH UPPER KERNS. THE WORD "BANK" IN GREEN LETTERS OUTLINED IN BLACK IS ALSO WITHIN THE CIRCLE EXTENDING ALONG AN ARC GENERALLY CONCENTRIC WITH, AND SUBSTANTIALLY ALONG, THE LOWER HALF OF THE CIRCLE. THE LETTER "N" OF "BANK" HAS WHITE PORTIONS ON THE LEADING EDGE OF THE LETTER AND ON THE LEADING EDGE OF THE LOWER ANGLED PORTION OF THE LETTER AND THE LETTER "K" HAS A WHITE PORTION ON ITS LEADING EDGE AND ON THE

CLASS 25—(Continued).

TRAILING EDGE OF THE LOWER LEG OF THE ANGLED PORTION OF THE LETTER "K". ENCLOSED WITHIN THE WORDS "DANK BANK" IS A PAIR OF EYEBALLS WITH EYELASHES OVER THEM, EYELIDS PARTIALLY COVERING THE EYEBALLS, AND A BURNING CIGARETTE BELOW THE RIGHTMOST EYEBALL. THE EYELASHES AND PUPILS OF THE EYEBALLS ARE BLACK. THE EYELIDS HAVE CENTRALLY-LOCATED BLACK GENERALLY-TRIANGULAR SECTIONS AT THEIR INSIDES WITH GREY SHADING AT THEIR OUTSIDES AND WHITE BETWEEN THE GREY SHADING AND THE GENERALLY-TRIANGULAR SECTIONS. OUTSIDE THE PUPILS, THE EYES ARE WHITE WITH RED BLOODSHOT STREAKS BELOW THE PUPILS. BELOW THE PUPILS IS A GENERALLY-TRIANGULAR SECTION IN BLACK WITH A LINE EXTENDING FROM THE GENERALLY-TRIANGULAR SECTION SLIGHTLY OUTWARD. THE CIGARETTE TAPERS BECOMING LARGER FROM LEFT TO RIGHT AND IS WHITE WITH GREY TO BLACK CONTOUR STREAKING AND HAS A BURNING ORANGE EMBER AT ITS RIGHTMOST PORTION. THE WHITE BACKGROUND IS NOT CLAIMED.

FOR BELTS; COATS; HATS; HOODED SWEAT SHIRTS; PANTS; SHIRTS; SWEAT SHIRTS; SWEATERS; T-SHIRTS (U.S. CLS. 22 AND 39). SALLY SHIH, EXAMINING ATTORNEY

SN 85-445,454. SHAWN LOREN, LLC, ACWORTH, GA. FILED 10-12-2011.



THE MARK CONSISTS OF A STYLIZED LETTER "S" SUPERIMPOSED OVER A STYLIZED LETTER "L". FOR FOOTWEAR (U.S. CLS. 22 AND 39). BARBARA GAYNOR, EXAMINING ATTORNEY

SN 85-445,459. TAIL OF THE DRAGON, LLC, ROBBINSVILLE, NC. FILED 10-12-2011.

MOONSHINER 28

THE MARK CONSISTS OF STANDARD CHARACTERS WITHOUT CLAIM TO ANY PARTICULAR FONT, STYLE, SIZE, OR COLOR. FOR T-SHIRTS; SHORT-SLEEVED OR LONG-SLEEVED T-SHIRTS (U.S. CLS. 22 AND 39). FIRST USE 11-30-2009; IN COMMERCE 11-30-2009. KAREN SEVERSON, EXAMINING ATTORNEY

CLASS 25—(Continued).

SN 85-445,508. WILD YONDER, LLC, BURLINGTON, VT.
FILED 10-12-2011.

Wild Yonder

THE MARK CONSISTS OF THE STYLIZED TEXT "WILD YONDER".

FOR HATS; HEADBANDS; T-SHIRTS (U.S. CLS. 22 AND 39).

FIRST USE 4-30-2011; IN COMMERCE 4-30-2011.
TEJBIR SINGH, EXAMINING ATTORNEY

SN 85-445,642. HOJOBAGS, PELLA, IA. FILED 10-12-2011.



NO CLAIM IS MADE TO THE EXCLUSIVE RIGHT TO USE "WEAR", APART FROM THE MARK AS SHOWN.

THE MARK CONSISTS OF THE STYLIZED TEXT "HOJO" INSIDE A PARTIAL OVAL. THE SIDE OF THE LETTER "H" MAKES UP THE LEFT SIDE OF THE OVAL. THE STYLIZED TEXT "WEAR" IS UNDERNEATH "HOJO".

FOR HATS; JACKETS; PANTS; SHIRTS (U.S. CLS. 22 AND 39).

JOHN GARTNER, EXAMINING ATTORNEY

SN 85-445,793. ROBERTS, JONATHAN, LAKELAND, FL.
FILED 10-12-2011.

POCKET7

THE MARK CONSISTS OF STANDARD CHARACTERS WITHOUT CLAIM TO ANY PARTICULAR FONT, STYLE, SIZE, OR COLOR.

FOR BEANIES; HOODED SWEAT SHIRTS; SHIRTS; SHIRTS AND SHORT-SLEEVED SHIRTS; SWEAT PANTS; SWEAT SHIRTS; TANK TOPS; WOMEN'S CLOTHING, NAMELY, SHIRTS, DRESSES, SKIRTS, BLOUSES (U.S. CLS. 22 AND 39).

BILL DAWE, EXAMINING ATTORNEY

CLASS 25—(Continued).

SN 85-445,831. N-M VENTURES, LLC, LAS VEGAS, NV.
FILED 10-12-2011.

GBDC

THE MARK CONSISTS OF STANDARD CHARACTERS WITHOUT CLAIM TO ANY PARTICULAR FONT, STYLE, SIZE, OR COLOR.

FOR ATHLETIC SHOES; BATHING SUITS; BEACH COVER-UPS; BELTS; BLAZERS; BLOUSES; BOOTIES; BOOTS; CAPS; FOOTWEAR; GLOVES; GOLF SHIRTS; HATS; HEADBANDS; HEADWEAR; HOSIERY; JACKETS; JEANS; JERSEYS; JOGGING SUITS; LEOTARDS; MITTENS; NECKTIES; NIGHTGOWNS; NIGHTSHIRTS; PAJAMA BOTTOMS; PAJAMAS; PANTS; PARKAS; POLO SHIRTS; PULLOVERS; RAINWEAR; ROBES; ROMPERS; SANDALS AND BEACH SHOES; SCARVES; SHIRTS; SHOES; SHORTS; SKIRTS; SLACKS; SLIPPERS; SNEAKERS; SOCKS; SUSPENDERS; SWEAT PANTS; SWEAT SHIRTS; SWEATERS; SWIMSUITS; T-SHIRTS; TANK TOPS; TURTLENECKS; UNDERGARMENTS; VESTS; VISORS; WARM UP SUITS; WIND RESISTANT JACKETS (U.S. CLS. 22 AND 39).

BRENDAN MCCAULEY, EXAMINING ATTORNEY

SN 85-445,841. THE SAUL ZAENTZ COMPANY, BERKELEY, CA. FILED 10-12-2011.

BAGGINS

THE MARK CONSISTS OF STANDARD CHARACTERS WITHOUT CLAIM TO ANY PARTICULAR FONT, STYLE, SIZE, OR COLOR.

OWNER OF U.S. REG. NOS. 2,925,671, 3,009,036 AND OTHERS.

FOR COSTUMES FOR USE IN ROLE-PLAYING GAMES; DRESSES; FOOTWEAR; HALLOWEEN COSTUMES; HEADWEAR; INFANT WEAR; JACKETS; PAJAMAS; PANTS; SHIRTS; SKIRTS; SOCKS; SWEAT SHIRTS; T-SHIRTS; TIES (U.S. CLS. 22 AND 39).

ANDREW LEASER, EXAMINING ATTORNEY

CLASS 25—(Continued).

SN 85-445,882. NBA DEVELOPMENT LEAGUE, LLC., SECA-CUS, NJ. FILED 10-12-2011.



NO CLAIM IS MADE TO THE EXCLUSIVE RIGHT TO USE "CANTON", APART FROM THE MARK AS SHOWN.

THE MARK CONSISTS OF A MAN HOLDING A SWORD. THE WORDS "CANTON CHARGE" APPEARING UNDER THE SWORD.

FOR CLOTHING, NAMELY HOSIERY, FOOTWEAR, BASKETBALL SHOES, BASKETBALL SNEAKERS, T-SHIRTS, SHIRTS, POLO SHIRTS, SWEATSHIRTS, SWEATPANTS, PANTS, TANK TOPS, JERSEYS, SHORTS, PAJAMAS, SPORT SHIRTS, RUGBY SHIRTS, SWEATERS, BELTS, TIES, NIGHTSHIRTS, HATS, CAPS, VISORS, WARM-UP SUITS, WARM-UP PANTS, WARM-UP TOPS/SHOOTING SHIRTS, JACKETS, WIND RESISTANT JACKETS, PARKAS, COATS, BABY BIBS NOT OF PAPER, HEAD BANDS, WRIST BANDS, APRONS, UNDERGARMENTS, BOXER SHORTS, SLACKS, EAR MUFFS, GLOVES, MITTENS, SCARVES, WOVEN AND KNIT SHIRTS, JERSEY DRESSES, DRESSES, CHEER-LEADING DRESSES AND UNIFORMS, SWIM WEAR, BATHING SUITS, SWIMSUITS, BIKINIS, TANKINIS, SWIM TRUNKS, BATHING TRUNKS, BOARD SHORTS, WET SUITS, BEACH COVER-UPS, BATHING SUIT COVER-UPS, BATHING SUIT WRAPS, SANDALS, BEACH SANDALS, BEACH HATS, SUN VISORS, SWIM CAPS, BATHING CAPS, NOVELTY HEADWEAR WITH ATTACHED WIGS (U.S. CLS. 22 AND 39).

ARETHA SOMERVILLE, EXAMINING ATTORNEY

SN 85-445,889. BACKMON, ELAINE, BRIDGEPORT, CT. FILED 10-12-2011.



THE MARK CONSISTS OF THE STYLIZED WORD "BROKE". TWO ARROWS CONNECTED TO THE LETTER "R". FOUR ARROWS CONNECTED TO THE LETTER "K". TWO ARROWS CONNECTED TO THE LETTER "E".

FOR BASEBALL CAPS; HOODED SWEATSHIRTS; JEANS; SNEAKERS; SWEATSHIRTS; T-SHIRTS (U.S. CLS. 22 AND 39).

STEVEN R. FINE, EXAMINING ATTORNEY

CLASS 25—(Continued).

SN 85-445,905. N-M VENTURES, LLC, LAS VEGAS, NV. FILED 10-12-2011.



FOR ATHLETIC SHOES; BATHING SUITS; BEACH COVER-UPS; BELTS; BLAZERS; BLOUSES; BOOTIES; BOOTS; CAPS; FOOTWEAR; GLOVES; GOLF SHIRTS; HATS; HEADBANDS; HEADWEAR; HOSIERY; JACKETS; JEANS; JERSEYS; JOGGING SUITS; LEOTARDS; MITTENS; NECKTIES; NIGHTGOWNS; NIGHTSHIRTS; PAJAMA BOTTOMS; PAJAMAS; PANTS; PARKAS; POLO SHIRTS; PULLOVERS; RAINWEAR; ROBES; ROMPERS; SANDALS AND BEACH SHOES; SCARVES; SHIRTS; SHOES; SHORTS; SKIRTS; SLACKS; SLIPPERS; SNEAKERS; SOCKS; SUSPENDERS; SWEAT PANTS; SWEAT SHIRTS; SWEATERS; SWIMSUITS; T-SHIRTS; TANK TOPS; TURTLENECKS; UNDERGARMENTS; VESTS; VISORS; WARM UP SUITS; WIND RESISTANT JACKETS (U.S. CLS. 22 AND 39).

BRENDAN MCCAULEY, EXAMINING ATTORNEY

SN 85-446,116. ICER KIDS LLC, NEW YORK, NY. FILED 10-12-2011.



THE MARK CONSISTS OF STANDARD CHARACTERS WITHOUT CLAIM TO ANY PARTICULAR FONT, STYLE, SIZE, OR COLOR.

FOR MEN'S, WOMEN'S AND CHILDREN'S CLOTHING, NAMELY, PANTS, SHIRTS, TOPS, HATS, SHOES, SWEAT SHIRTS, T-SHIRTS AND COATS (U.S. CLS. 22 AND 39).

LINDA M. KING, EXAMINING ATTORNEY

SN 85-446,119. ICER KIDS LLC, NEW YORK, NY. FILED 10-12-2011.



THE MARK CONSISTS OF STANDARD CHARACTERS WITHOUT CLAIM TO ANY PARTICULAR FONT, STYLE, SIZE, OR COLOR.

NO CLAIM IS MADE TO THE EXCLUSIVE RIGHT TO USE "GIRL", APART FROM THE MARK AS SHOWN.

FOR MEN'S, WOMEN'S AND CHILDREN'S CLOTHING, NAMELY, PANTS, SHIRTS, TOPS, HATS, SHOES, SWEAT SHIRTS, T-SHIRTS AND COATS (U.S. CLS. 22 AND 39).

LINDA M. KING, EXAMINING ATTORNEY

CLASS 25—(Continued).

SN 85-446,252. JOCKEY INTERNATIONAL, INC., KENOSHA, WI. FILED 10-13-2011.

DIAMOND BRIGHT

THE MARK CONSISTS OF STANDARD CHARACTERS WITHOUT CLAIM TO ANY PARTICULAR FONT, STYLE, SIZE, OR COLOR.

FOR UNDERWEAR TOPS AND BOTTOMS; PANTIES; CAMISOLES; TANKS; BRAS; SOCKS; HOSIERY; LONG UNDERWEAR; ACTIVEWEAR, NAMELY, TOPS AND BOTTOMS, BRAS, TANKS, T-SHIRTS, PANTS, SHORTS AND JACKETS; SPORTSWEAR, NAMELY, TOPS AND BOTTOMS, BRAS, TANKS, T-SHIRTS, PANTS, SHORTS AND JACKETS; SLEEPWEAR; SHAPEWEAR, NAMELY, TOPS AND BOTTOMS, TANKS, CAMISOLES, SLIPS AND BODYSUITS; AND THERMAL UNDERWEAR TOPS AND BOTTOMS (U.S. CLS. 22 AND 39).

WILLIAM ROSSMAN, EXAMINING ATTORNEY

SN 85-446,256. GLENN LAIKEN, KNOXVILLE, TN. FILED 10-13-2011.

BIBLE BLESSINGS

THE MARK CONSISTS OF STANDARD CHARACTERS WITHOUT CLAIM TO ANY PARTICULAR FONT, STYLE, SIZE, OR COLOR.

FOR MEN'S AND WOMEN'S CLOTHING, NAMELY, TOPS, BOTTOMS, JACKETS, SHIRTS, PANTS, FOOTWEAR, HATS, AND BELTS (U.S. CLS. 22 AND 39).

MICHAEL GAAFAR, EXAMINING ATTORNEY

SN 85-446,275. UNCOMMON FIT, HIGHTSTOWN, NJ. FILED 10-13-2011.

Uncommon Fit

THE MARK CONSISTS OF STANDARD CHARACTERS WITHOUT CLAIM TO ANY PARTICULAR FONT, STYLE, SIZE, OR COLOR.

FOR ATHLETIC APPAREL, NAMELY, SHIRTS, PANTS, JACKETS, FOOTWEAR, HATS AND CAPS, ATHLETIC UNIFORMS (U.S. CLS. 22 AND 39).

FIRST USE 9-1-2010; IN COMMERCE 10-1-2010.

ERNEST SHOSHO, EXAMINING ATTORNEY

CLASS 25—(Continued).

SN 85-446,380. EWING, ADAM, TOANO, VA. FILED 10-13-2011.

BAD POPO

THE MARK CONSISTS OF STANDARD CHARACTERS WITHOUT CLAIM TO ANY PARTICULAR FONT, STYLE, SIZE, OR COLOR.

FOR HATS; JEANS; SHORTS; T-SHIRTS (U.S. CLS. 22 AND 39).

ARETHA SOMERVILLE, EXAMINING ATTORNEY

SN 85-446,457. PAUL MICHAELS, HOUSTON, TX. FILED 10-13-2011.

CONTRAGIRL

THE MARK CONSISTS OF STANDARD CHARACTERS WITHOUT CLAIM TO ANY PARTICULAR FONT, STYLE, SIZE, OR COLOR.

OWNER OF U.S. REG. NO. 3,036,207.

FOR CLOTHING, NAMELY, SHIRTS, PANTS, HATS, CAPS, NIGHTWEAR, UNDERWEAR, LINGERIE, SWIMWEAR, COATS, SOCKS, AND PANTIES (U.S. CLS. 22 AND 39).

FIRST USE 6-29-2002; IN COMMERCE 10-1-2011.

AMY ALFIERI, EXAMINING ATTORNEY

SN 85-446,552. MOORE, ANNE, AUSTIN, TX. FILED 10-13-2011.

Anne Moore

THE MARK CONSISTS OF STANDARD CHARACTERS WITHOUT CLAIM TO ANY PARTICULAR FONT, STYLE, SIZE, OR COLOR.

THE NAME "ANNE MOORE" IDENTIFIES A LIVING INDIVIDUAL WHOSE CONSENT IS OF RECORD.

FOR CLOTHING, NAMELY, SHIRTS, PANTS, SKIRTS, HEADBANDS, JACKETS, TOPS, DRESSES, BLOUSES, BOTTOMS, BELTS, SHOES, ATHLETIC APPAREL, NAMELY, SHIRTS, PANTS, JACKETS, FOOTWEAR, HATS AND CAPS, ATHLETIC UNIFORMS; BATHING SUITS; BATHROBES; BOOTS; BRASSIERES; BRAS; CORSELETS; LADIES' UNDERWEAR; LADIES' SUITS; LADIES' BOOTS; LEGGINGS; PANTIES, SHORTS AND BRIEFS; PEACOATS; SWEATSHIRTS; SWIMWEAR; T-SHIRTS; UNIFORMS; ARTIFICIAL FLOWER HEADDRESSES; APRONS; BALL GOWNS; BANDANAS; BASEBALL CAPS AND HATS; BERETS; BIKINIS; BATHING SUITS; BEACH COVER-UPS; FUR HATS; FUR MUFFS; BEACHWEAR; BELTS; GLOVES; GOLF CAPS; BUCKET CAPS; CAFTANS; HAT BANDS; HATS; HATS FOR INFANTS, BABIES, TODDLERS AND CHILDREN; HEAD SCARVES; HEAD SWEATBANDS; HEAD WEAR; HEADBANDS; HEADBANDS AGAINST SWEATING;

CLASS 25—(Continued).

HEADWEAR; HOODED SWEAT SHIRTS; CANVAS SHOES; CAP PEAKS; CAP VISORS; JEANS; KAFTANS; KNITTED CAPS; KNITTED GLOVES; CAPS; CARDIGANS; CHILDREN'S HEADWEAR; CLOTHING, NAMELY, BASE LAYERS; LEATHER HEADWEAR; LEGGINGS; COMPETITORS' NUMBERS OF TEXTILE; LOUNGEWEAR; DRESSING GOWNS; FLIP FLOPS; MITTENS; MILLINERY, NAMELY, FASCINATORS; BOOTS; BRIDESMAID DRESSES; NIGHTDRESSES; BODY LINEN; NIGHTWEAR; NOVELTY HEADWEAR WITH ATTACHED WIGS; BLOUSES; PAPER HATS FOR USE AS CLOTHING ITEMS; PERSPIRATION ABSORBENT STRAP TO BE USED IN THE BILL OF A HAT; RAIN HATS; RAIN WEAR; ROBES; SANDALS AND BEACH SHOES; SARONGS; SASHES; SCARVES; SHAWLS; SHAWLS AND HEADSCARVES; SHAWLS AND STOLEES; SHIRTS; SHOES; SHORT-SLEEVED OR LONG-SLEEVED T-SHIRTS; SHOULDER WRAPS; SILK SCARVES; SKIRTS AND DRESSES; SLEEPING GARMENTS; SMALL HATS; SUNDRESSES; SUN VISORS; SWEAT BANDS; SWEAT PANTS; SWEAT SHIRTS; SWIMWEAR; TEE SHIRTS; TUNICS; TURBANS; UNDERWEAR; VEILS; WOMEN'S HATS AND HOODS; WOOLLY HATS; WRISTBANDS; YOGA PANTS; YOGA SHIRTS (U.S. CLS. 22 AND 39).

JEFFREY LOOK, EXAMINING ATTORNEY

SN 85-446,580. NOONAN, MICHAEL, KENNESAW, GA. FILED 10-13-2011.

Thanks Prohibition

THE MARK CONSISTS OF STANDARD CHARACTERS WITHOUT CLAIM TO ANY PARTICULAR FONT, STYLE, SIZE, OR COLOR.

FOR CLOTHING, NAMELY, T-SHIRTS, SWEAT SHIRTS, HOODED PULLOVERS, GOLF SHIRTS, DRESS SHIRTS, TOPS, PANTS, SHORTS, GYM SHORTS, SWEAT PANTS, JEANS, SLACKS, CAPRIS, WRISTBANDS, HEADBANDS, PAJAMAS, JACKETS, DRESSES, BANDANAS, GOWNS, ROBES, UNDERWEAR, LINGERIE, SOCKS, SLIPPERS, SHOES, FLIP FLOPS, BOOTS, HATS, VISORS, EARMUFFS, NECK TUBES, HAND-WARMERS, SCARVES, AND GLOVES (U.S. CLS. 22 AND 39).

EMILY CARLSEN, EXAMINING ATTORNEY

SN 85-446,610. GULFSTYLE INC., FORT WALTON BEACH, FL. FILED 10-13-2011.

Livin' Right

THE MARK CONSISTS OF STANDARD CHARACTERS WITHOUT CLAIM TO ANY PARTICULAR FONT, STYLE, SIZE, OR COLOR.

FOR DRESS SHIRTS; PANTS; POLO SHIRTS; T-SHIRTS (U.S. CLS. 22 AND 39).

CHRISTINA SOBRAL, EXAMINING ATTORNEY

CLASS 25—(Continued).

SN 85-446,767. RAMATEX INTERNATIONAL CORP., FAIRFIELD, NJ. FILED 10-13-2011.

BAJA JOE

THE MARK CONSISTS OF STANDARD CHARACTERS WITHOUT CLAIM TO ANY PARTICULAR FONT, STYLE, SIZE, OR COLOR.

FOR JACKETS; PONCHOS; PULLOVERS; SHIRTS (U.S. CLS. 22 AND 39).

SALLY SHIH, EXAMINING ATTORNEY

SN 85-446,777. HOLGUIN, RALPH, BELLFLOWER, CA. FILED 10-13-2011.

VMLF

THE MARK CONSISTS OF STANDARD CHARACTERS WITHOUT CLAIM TO ANY PARTICULAR FONT, STYLE, SIZE, OR COLOR.

FOR CLOTHING, NAMELY, TOPS, BOTTOMS, T-SHIRTS, SHIRTS, JEANS AND PANTS (U.S. CLS. 22 AND 39).

LINDA E. BLOHM, EXAMINING ATTORNEY

SN 85-446,824. HERO & LEANDER LLC, MALIBU, CA. FILED 10-13-2011.

Get Some Action

THE MARK CONSISTS OF STANDARD CHARACTERS WITHOUT CLAIM TO ANY PARTICULAR FONT, STYLE, SIZE, OR COLOR.

FOR CLOTHING, NAMELY, ATHLETIC SWIMWEAR, WORKOUT PANTS, T-SHIRTS, HOODED SWEATSHIRTS, AND SWIM CAPS (U.S. CLS. 22 AND 39).

GENE MACIOL, EXAMINING ATTORNEY

CLASS 25—(Continued).

SN 85-446,835. JJEFFREY B. MATTHEWS, CHATTANOOGA, TN. AND LASHERRIL MATTHEWS, CHATTANOOGA, TN. FILED 10-13-2011.

EVERY DAY IS A GOOD DAY

THE MARK CONSISTS OF STANDARD CHARACTERS WITHOUT CLAIM TO ANY PARTICULAR FONT, STYLE, SIZE, OR COLOR.

FOR T-SHIRTS, POLO SHIRTS, BUTTON DOWN SHIRTS, TANK TOPS AND CAPS (U.S. CLS. 22 AND 39).
FIRST USE 9-12-2011; IN COMMERCE 9-12-2011.
C. DIONNE CLYBURN, EXAMINING ATTORNEY

SN 85-446,858. MUFFINMILK, LLC., NEW YORK, NY. FILED 10-13-2011.

MUFFINMILK

THE MARK CONSISTS OF STANDARD CHARACTERS WITHOUT CLAIM TO ANY PARTICULAR FONT, STYLE, SIZE, OR COLOR.

FOR SHORT-SLEEVED OR LONG-SLEEVED T-SHIRTS; SWEATSHIRTS (U.S. CLS. 22 AND 39).
FIRST USE 12-25-2008; IN COMMERCE 1-1-2009.
GEORGE LORENZO, EXAMINING ATTORNEY

SN 85-446,874. PATRICK LANE COMPANY, DBA LANE BOOT COMPANY, FORT WORTH, TX. FILED 10-13-2011.



THE MARK CONSISTS OF THE WORDING "LANE" ABOVE TWO HORIZONTAL CURVED LINES AND FOUR VERTICAL CURVED LINES.

FOR BOOTS (U.S. CLS. 22 AND 39).
FIRST USE 6-12-2008; IN COMMERCE 9-30-2008.
KIMBERLY PERRY, EXAMINING ATTORNEY

CLASS 25—(Continued).

SN 85-446,878. CHANGA C. INGRAM, COLUMBIA, MD. AND DAMANI K. INGRAM, COLUMBIA, MD. FILED 10-13-2011.

Cageaholic

THE MARK CONSISTS OF STANDARD CHARACTERS WITHOUT CLAIM TO ANY PARTICULAR FONT, STYLE, SIZE, OR COLOR.

FOR ATHLETIC APPAREL, NAMELY, SHIRTS, PANTS, JACKETS, FOOTWEAR, HATS AND CAPS, ATHLETIC UNIFORMS (U.S. CLS. 22 AND 39).
LINDA E. BLOHM, EXAMINING ATTORNEY

SN 85-446,950. ROOCHI TRADERS, INC, COMMERCE, CA. FILED 10-13-2011.

PRO POWER

THE MARK CONSISTS OF STANDARD CHARACTERS WITHOUT CLAIM TO ANY PARTICULAR FONT, STYLE, SIZE, OR COLOR.

FOR CLOTHING, NAMELY, SHIRTS, JACKETS, PANTS, SHORTS, T-SHIRTS, SWEAT PANTS, SWEAT SHIRTS, SWEAT SUITS, TANK TOPS, TRACK SUITS, VESTS, DRESSES; INFANT AND TODDLER CLOTHING, NAMELY, ONE-PIECE CLOTHING AND SHIRTS (U.S. CLS. 22 AND 39).

FIRST USE 7-30-2006; IN COMMERCE 7-30-2006.
LAURIE KAUFMAN, EXAMINING ATTORNEY

SN 85-447,213. MIYASHIRO, DON S., PEARL CITY, HI. FILED 10-13-2011.

420 AM KBUD

THE MARK CONSISTS OF STANDARD CHARACTERS WITHOUT CLAIM TO ANY PARTICULAR FONT, STYLE, SIZE, OR COLOR.

FOR SHIRTS; T-SHIRTS (U.S. CLS. 22 AND 39).
LEIGH LOWRY, EXAMINING ATTORNEY

CLASS 25—(Continued).

SN 85-447,266. AÇAI BERRY FASHION WEAR, INC., ORANGE BEACH, AL. FILED 10-13-2011.

Where Fitness is Fashion

THE MARK CONSISTS OF STANDARD CHARACTERS WITHOUT CLAIM TO ANY PARTICULAR FONT, STYLE, SIZE, OR COLOR.

FOR ATHLETIC APPAREL, NAMELY, SHIRTS, PANTS, JACKETS, FOOTWEAR, HATS AND CAPS, ATHLETIC UNIFORMS (U.S. CLS. 22 AND 39).

FIRST USE 12-1-2009; IN COMMERCE 8-5-2011.
MARY ROSSMAN, EXAMINING ATTORNEY

SN 85-447,282. SOOK HAN LIM, AKA MADDIE LIM, SHANGHAI, CHINA, FILED 10-13-2011.

L I N G U O

THE MARK CONSISTS OF CAPITAL LETTERS OF "LINGUO".

THE WORDING "LINGUO" HAS NO MEANING IN A FOREIGN LANGUAGE.

FOR WOMEN'S CLOTHING, NAMELY, SHIRTS, DRESSES, SKIRTS, BLOUSES (U.S. CLS. 22 AND 39).

FIRST USE 1-1-2011; IN COMMERCE 1-1-2011.
B. PARADEWELAI, EXAMINING ATTORNEY

SN 85-447,291. BRANDGENUITY, LLC, NEW YORK, NY. FILED 10-13-2011.

SUCK FOR LUCK

THE MARK CONSISTS OF STANDARD CHARACTERS WITHOUT CLAIM TO ANY PARTICULAR FONT, STYLE, SIZE, OR COLOR.

FOR CLOTHING, NAMELY, HATS, BASEBALL CAPS AND HATS, T-SHIRTS, GOLF SHIRTS, SWEAT SHIRTS, HOODED SWEAT SHIRTS, SWEAT PANTS, SHORTS AND BOXER SHORTS (U.S. CLS. 22 AND 39).

BRIAN CALLAGHAN, EXAMINING ATTORNEY

CLASS 25—(Continued).

SN 85-447,370. ELIZABETH ROSE GUILLAUME, SOUTH OZONE PARK, NY. FILED 10-14-2011.

erg intimates

THE MARK CONSISTS OF STANDARD CHARACTERS WITHOUT CLAIM TO ANY PARTICULAR FONT, STYLE, SIZE, OR COLOR.

NO CLAIM IS MADE TO THE EXCLUSIVE RIGHT TO USE "INTIMATES", APART FROM THE MARK AS SHOWN.

FOR BRAS; BRIEFS; DISPOSABLE UNDERWEAR; GIRDLES; LADIES' UNDERWEAR; LEOTARDS AND TIGHTS FOR WOMEN, MEN AND CHILDREN OF NYLON, COTTON OR OTHER TEXTILE FIBERS; LINGERIE; PANTIES; THERMAL UNDERWEAR; THONGS; TIGHTS; UNDERWEAR (U.S. CLS. 22 AND 39).

FIRST USE 10-2-2011; IN COMMERCE 10-2-2011.
KAREN K. BUSH, EXAMINING ATTORNEY

SN 85-447,392. POSITIVELY DETROIT, LLC, FERNDALE, MI. FILED 10-14-2011.



NO CLAIM IS MADE TO THE EXCLUSIVE RIGHT TO USE THE SPIRIT OF DETROIT STATUE, APART FROM THE MARK AS SHOWN.

THE MARK CONSISTS OF THE WORDING "POSITIVELY DETROIT", THE STATUE SPIRIT OF DETROIT WHICH IS A SCULPTURE OF A MALE HUMAN BEING WITH A FAMILY IN ONE HAND AND A SPHERE IN THE OTHER HAND AND ALL APPEARING UPON A RECTANGLE.

FOR WEARABLE GARMENTS AND CLOTHING, NAMELY, SHIRTS (U.S. CLS. 22 AND 39).

FIRST USE 10-12-2011; IN COMMERCE 10-12-2011.
EDWARD NELSON, EXAMINING ATTORNEY

SN 85-447,461. WINSTON-SALEM STATE UNIVERSITY, RALEIGH, NC. FILED 10-14-2011.

RMT

THE MARK CONSISTS OF STANDARD CHARACTERS WITHOUT CLAIM TO ANY PARTICULAR FONT, STYLE, SIZE, OR COLOR.

FOR CLOTHING, NAMELY, SHIRTS, TIES AND HATS (U.S. CLS. 22 AND 39).

FIRST USE 7-15-2009; IN COMMERCE 7-15-2009.
SIMON TENG, EXAMINING ATTORNEY

CLASS 25—(Continued).

SN 85-447,497. ACCELET CORPORATION, MILPITAS, CA. FILED 10-14-2011.

DELUXSEY

THE MARK CONSISTS OF STANDARD CHARACTERS WITHOUT CLAIM TO ANY PARTICULAR FONT, STYLE, SIZE, OR COLOR.

FOR CLOTHING FOR BABIES, TODDLERS AND CHILDREN, TREATED WITH FIRE AND HEAT RETARDANTS, NAMELY, PAJAMAS, JACKETS, SHIRTS, PANTS, JUMPERS; MEN'S AND WOMEN'S JACKETS, COATS, TROUSERS, VESTS; MEN'S SUITS, WOMEN'S SUITS; WOMEN'S CLOTHING, NAMELY, SHIRTS, DRESSES, SKIRTS, BLOUSES (U.S. CLS. 22 AND 39).

JENNIFER DIXON, EXAMINING ATTORNEY

CLASS 25—(Continued).

SN 85-447,543. RAG DOLL MERCHANDISING, INC., WOODLAND HILLS, CA. FILED 10-14-2011.

AEROSMITH'S BLUE ARMY

THE MARK CONSISTS OF STANDARD CHARACTERS WITHOUT CLAIM TO ANY PARTICULAR FONT, STYLE, SIZE, OR COLOR.

OWNER OF U.S. REG. NOS. 1,552,802, 2,954,199 AND 3,224,353.

FOR CLOTHING, NAMELY, SHIRTS, T-SHIRTS, POLO SHIRTS, TANK TOPS, SWEATERS, SWEATSHIRTS, BLOUSES, JERSEYS, PANTS, JEANS, SHORTS, SKIRTS, DRESSES, COATS, JACKETS, VESTS, SWIMWEAR, LOUNGEWEAR, SLEEPWEAR, UNDERWEAR, BOXER SHORTS, SOCKS, LEGGINGS, HOSIERY, SCARVES, GLOVES, MITTENS, BANDANAS; BELTS; BABY BIBS NOT OF PAPER; HEADWEAR; FOOTWEAR (U.S. CLS. 22 AND 39).

BRIAN PINO, EXAMINING ATTORNEY

SN 85-447,524. EMERALD AUGUST, ATLANTA, GA. FILED 10-14-2011.



NO CLAIM IS MADE TO THE EXCLUSIVE RIGHT TO USE "QUALITY GOODS" AND "EST 2011", APART FROM THE MARK AS SHOWN.

THE STIPLING IS FOR SHADING PURPOSES ONLY.

THE MARK CONSISTS OF A CURVED RECTANGLE SHAPE WITH THE STYLIZED TEXT "QUALITY GOODS EMERALD AUGUST EST 2011".

FOR DRESSES; LEGGINGS; PANTS; SCARVES; SKIRTS; T-SHIRTS (U.S. CLS. 22 AND 39).

CHRISTOPHER LAW, EXAMINING ATTORNEY

SN 85-447,546. RAG DOLL MERCHANDISING, INC., WOODLAND HILLS, CA. FILED 10-14-2011.

THE BLUE ARMY

THE MARK CONSISTS OF STANDARD CHARACTERS WITHOUT CLAIM TO ANY PARTICULAR FONT, STYLE, SIZE, OR COLOR.

FOR CLOTHING, NAMELY, SHIRTS, T-SHIRTS, POLO SHIRTS, TANK TOPS, SWEATERS, SWEATSHIRTS, BLOUSES, JERSEYS, PANTS, JEANS, SHORTS, SKIRTS, DRESSES, COATS, JACKETS, VESTS, SWIMWEAR, LOUNGEWEAR, SLEEPWEAR, UNDERWEAR, BOXER SHORTS, SOCKS, LEGGINGS, HOSIERY, SCARVES, GLOVES, MITTENS, BANDANAS; BELTS; BABY BIBS NOT OF PAPER; HEADWEAR; FOOTWEAR (U.S. CLS. 22 AND 39).

BRIAN PINO, EXAMINING ATTORNEY

CLASS 25—(Continued).

SN 85-447,599. EQUIBANK, LLC, ENGLEWOOD, CO. FILED 10-14-2011.



THE COLOR(S) RED, ORANGE, WHITE AND BLACK IS/ ARE CLAIMED AS A FEATURE OF THE MARK.
 THE MARK CONSISTS OF A STAR DESIGN OF FOUR FLARES IN ALTERNATING RED AND ORANGE FLARES ABOVE THE WORD "SANTIO" IN WHITE, ALL ON A BLACK BACKGROUND.
 FOR BREECHES (U.S. CLS. 22 AND 39).
 FIRST USE 7-31-2010; IN COMMERCE 7-31-2010.
 LINDA MICKLEBURGH, EXAMINING ATTORNEY

CLASS 25—(Continued).

SN 85-447,641. EQUIBANK, LLC, ENGLEWOOD, CO. FILED 10-14-2011.



THE COLOR(S) TEAL GREEN, AQUA GREEN AND WHITE IS/ARE CLAIMED AS A FEATURE OF THE MARK.
 THE MARK CONSISTS OF THE WORD "NATHALIE" IN WHITE SCRIPT ON A TEAL GREEN BACKGROUND SURROUNDED BY AN AQUA GREEN BORDER, WITH A WHITE AND AQUA GREEN CROWN OVER TOP OF THE "N".
 FOR BREECHES (U.S. CLS. 22 AND 39).
 FIRST USE 7-31-2010; IN COMMERCE 7-31-2010.
 LINDA MICKLEBURGH, EXAMINING ATTORNEY

SN 85-447,760. GREATER MIAMI BASEBALL CLUB, L.P., ST. PETERSBURG, FL. FILED 10-14-2011.

SN 85-447,637. DENNIS ENARSON, DBA MARKIT DENIM, LA MESA, CA. FILED 10-14-2011.



NO CLAIM IS MADE TO THE EXCLUSIVE RIGHT TO USE "MARKIT", APART FROM THE MARK AS SHOWN.
 THE MARK CONSISTS OF A SPECIALIZED AIRBRUSHED STYLE CAPITAL "M" WITH A CIRCLE AROUND THE "M" AND A HORIZONTAL LINE GOING THROUGH THE MIDDLE OF THE "M" IN FRONT OF THE CAPITAL AIRBRUSHED STYLE LETTERS "ARKIT".
 FOR DENIM JEANS, HATS, JACKETS, AND SHIRTS (U.S. CLS. 22 AND 39).
 EDWARD FENNESSY, EXAMINING ATTORNEY



OWNER OF U.S. REG. NO. 1,891,136.
 NO CLAIM IS MADE TO THE EXCLUSIVE RIGHT TO USE "FORT MYERS", APART FROM THE MARK AS SHOWN.
 THE MARK CONSISTS OF A BODY OF WATER WITH A SAILBOAT SAILING TOWARDS A BEACH WITH "FORT MYERS MIRACLE" ABOVE WITH A PALM TREE AND BASEBALL INCORPORATED INTO THE WORDING.
 FOR CLOTHING, NAMELY, APRONS, ATHLETIC UNIFORMS, BANDANAS, BOXER SHORTS, CAPS, CLOTH BABY BIBS, COATS, GOLF SHIRTS, GYM SHORTS, GYM SUITS, HATS, JACKETS, JERSEYS, JOGGING SUITS, KNIT SHIRTS, PAJAMAS, POLO SHIRTS, PONCHOS, PULLOVERS, RAIN COATS, RAINWEAR, SWEATERS, SWEAT PANTS, SWEAT SHIRTS, SWEAT SUITS, SOCKS, SPORT SHIRTS, T- SHIRTS, TANK TOPS, TIES, VISORS, WIND RESISTANT JACKETS AND WRISTBANDS (U.S. CLS. 22 AND 39).
 FIRST USE 10-1-2010; IN COMMERCE 10-1-2010.
 EMILY CARLSEN, EXAMINING ATTORNEY

CLASS 25—(Continued).

SN 85-447,786. MILLER, NICOLE, ATLANTA, GA. FILED 10-14-2011.

*Adriano
Diamante*

THE NAME(S), PORTRAIT(S), AND/OR SIGNATURE(S) SHOWN IN THE MARK DOES NOT IDENTIFY A PARTICULAR LIVING INDIVIDUAL.

THE MARK CONSISTS OF THE STYLIZED TERMS "ADRIANO DIAMANTE". THE LETTER "A" IN "ADRIANO" CONNECTS TO THE LETTER "D" IN "DIAMANTE".

THE ENGLISH TRANSLATION OF THE WORD "DIAMANTE" IN THE MARK IS "DIAMOND".

FOR ESPADRILLES; FOOTWEAR FOR MEN AND WOMEN; FOOTWEAR FOR WOMEN; FOOTWEAR, NAMELY, PUMPS; LEATHER SHOES; SANDALS; SHOES; STILETTO HEELS (U.S. CLS. 22 AND 39).

FIRST USE 9-0-2011; IN COMMERCE 9-0-2011.
APRIL ROACH, EXAMINING ATTORNEY

SN 85-447,849. MICKEYBLU AUSTRALIA PTY LTD, HOVEA, WA, AUSTRALIA, FILED 10-14-2011.

LOVE THE WAY YOU MOVE

THE MARK CONSISTS OF STANDARD CHARACTERS WITHOUT CLAIM TO ANY PARTICULAR FONT, STYLE, SIZE, OR COLOR.

FOR GYM PANTS; HATS; POLO SHIRTS; SHIRTS (U.S. CLS. 22 AND 39).

RENEE MCCRAY, EXAMINING ATTORNEY

SN 85-447,885. DIAMOND MOUNTAIN DISTRIBUTORS LLC, HENDERSON, NV. FILED 10-14-2011.

JUST VEGAS

THE MARK CONSISTS OF STANDARD CHARACTERS WITHOUT CLAIM TO ANY PARTICULAR FONT, STYLE, SIZE, OR COLOR.

NO CLAIM IS MADE TO THE EXCLUSIVE RIGHT TO USE "VEGAS", APART FROM THE MARK AS SHOWN.

FOR CLOTHING, NAMELY, T-SHIRTS AND JACKETS (U.S. CLS. 22 AND 39).

PATRICIA EVANKO, EXAMINING ATTORNEY

CLASS 25—(Continued).

SN 85-448,105. J AND A SHOE CO., INC., GARDENA, CA. FILED 10-14-2011.

SIR. ALEXANDER

THE MARK CONSISTS OF STANDARD CHARACTERS WITHOUT CLAIM TO ANY PARTICULAR FONT, STYLE, SIZE, OR COLOR.

THE NAME "SIR. ALEXANDER" DOES NOT IDENTIFY A LIVING INDIVIDUAL.

FOR FOOTWEAR (U.S. CLS. 22 AND 39).
NANCY CLARKE, EXAMINING ATTORNEY

SN 85-448,161. ENGLEHART, TRAVIS, KILLEEN, TX. FILED 10-14-2011.

ANGRY DIESEL

THE MARK CONSISTS OF STANDARD CHARACTERS WITHOUT CLAIM TO ANY PARTICULAR FONT, STYLE, SIZE, OR COLOR.

FOR CLOTHING, NAMELY, T-SHIRTS, HATS (U.S. CLS. 22 AND 39).

ADA HAN, EXAMINING ATTORNEY

SN 85-448,165. LAMBKE, LOGAN A., ASHBURN, VA. AND MALTZ, DYLAN, ASHBURN, VA. FILED 10-14-2011.

venetic

THE MARK CONSISTS OF STANDARD CHARACTERS WITHOUT CLAIM TO ANY PARTICULAR FONT, STYLE, SIZE, OR COLOR.

FOR SHORTS; SWIMWEAR (U.S. CLS. 22 AND 39).
APRIL HESIK, EXAMINING ATTORNEY

CLASS 25—(Continued).

SN 85-448,212. NASCA LLC, MT PLEASANT, SC. FILED 10-14-2011.

NASCA

THE MARK CONSISTS OF STANDARD CHARACTERS WITHOUT CLAIM TO ANY PARTICULAR FONT, STYLE, SIZE, OR COLOR.
FOR T-SHIRTS (U.S. CLS. 22 AND 39).
CHRISTOPHER BUONGIORNO, EXAMINING ATTORNEY

SN 85-448,214. JEFFRIES, JOHN, MONTECITO, CA. FILED 10-14-2011.

LOCAL

THE MARK CONSISTS OF THE STYLIZED WORDING "LOCAL I" WHERE THE NUMERAL "1" IS LOCATED NEAR THE TOP OF, AND FORMS A PORTION OF, THE LETTER "C" IN THE LETTERS "LOCAL".

FOR CLOTHING, NAMELY, TOPS, BOTTOMS, HATS, T-SHIRTS, PANTS, FOOTWEAR, HEADBANDS, WRIST BANDS, SHORTS, SWIMWEAR (U.S. CLS. 22 AND 39).
JAY BESCH, EXAMINING ATTORNEY

SN 85-448,283. FILS-AIME EDERSON, BROOKLYN, NY. FILED 10-15-2011.

FEDS

THE MARK CONSISTS OF STANDARD CHARACTERS WITHOUT CLAIM TO ANY PARTICULAR FONT, STYLE, SIZE, OR COLOR.

FOR BELTS FOR CLOTHING; BOOTS; BOTTOMS; CLOTHING, NAMELY, KHAKIS; COATS; HATS; HOODS; JACKETS; JEANS; LONG-SLEEVED SHIRTS; SNEAKERS; SPORTS CAPS AND HATS; SWEATERS; TOPS; WEARABLE GARMENTS AND CLOTHING, NAMELY, SHIRTS (U.S. CLS. 22 AND 39).
FIRST USE 10-14-2011; IN COMMERCE 10-14-2011.
ELI HELLMAN, EXAMINING ATTORNEY

CLASS 25—(Continued).

SN 85-448,360. GREGORY DINUR, ATLANTA, GA. FILED 10-15-2011.

TAILBACK U

THE MARK CONSISTS OF STANDARD CHARACTERS WITHOUT CLAIM TO ANY PARTICULAR FONT, STYLE, SIZE, OR COLOR.

THE ENGLISH TRANSLATION OF "U" IN THE MARK IS "UNIVERSITY".

FOR SHORT-SLEEVED OR LONG-SLEEVED T-SHIRTS; T-SHIRTS FOR MEN, WOMEN, CHILDREN, BABIES (U.S. CLS. 22 AND 39).
LAKEISHA LEWIS, EXAMINING ATTORNEY

SN 85-448,419. TYSON, FRANK L., LANSING, MI. FILED 10-16-2011.



NO CLAIM IS MADE TO THE EXCLUSIVE RIGHT TO USE "COLLECTION", APART FROM THE MARK AS SHOWN.

THE MARK CONSISTS OF THE WORDS "MAD PANDA" IN A RECTANGULAR BACKGROUND WITH STYLIZED CROWNS ON THE ENDS AND THE WORDING "COLLECTION" BELOW.

FOR APPAREL FOR DANCERS, NAMELY, TEE SHIRTS, SWEATSHIRTS, PANTS, LEGGINGS, SHORTS AND JACKETS; ATHLETIC APPAREL, NAMELY, SHIRTS, PANTS, JACKETS, FOOTWEAR, HATS AND CAPS, ATHLETIC UNIFORMS; BUTTON DOWN SHIRTS; CHILDREN'S AND INFANT'S APPAREL, NAMELY, JUMPERS, OVERALL SLEEPWEAR, PAJAMAS, ROMPERS AND ONE-PIECE GARMENTS; CHILDREN'S AND INFANTS' APPAREL TREATED WITH FIRE AND HEAT RETARDANTS, NAMELY, JUMPERS, OVERALL SLEEPWEAR, PAJAMAS, ROMPERS AND ONE-PIECE GARMENTS; CLOTHING FOR BABIES, TODDLERS AND CHILDREN, TREATED WITH FIRE AND HEAT RETARDANTS, NAMELY, PAJAMAS, JACKETS, SHIRTS, PANTS, JUMPERS; COLLARED SHIRTS; DRESS SHIRTS; GLOVES FOR APPAREL; HOODED SWEAT SHIRTS; KNIT SHIRTS; LONG-SLEEVED SHIRTS; POLO SHIRTS; SHIRTS AND SHORT-SLEEVED SHIRTS; SHIRTS FOR INFANTS, BABIES, TODDLERS AND CHILDREN; SHORT-SLEEVED OR LONG-SLEEVED T-SHIRTS; SHORT-SLEEVED SHIRTS; SLEEP SHIRTS; SNAP CROTCH SHIRTS FOR INFANTS AND TODDLERS; T-SHIRTS (U.S. CLS. 22 AND 39).

WILLIAM VERHOSEK, EXAMINING ATTORNEY

CLASS 25—(Continued).

SN 85-448,479. BAREFOOT CREATIONS LLC, DBA SOFT STAR SHOES, CORVALLIS, OR. FILED 10-16-2011.

RunAmoc

THE MARK CONSISTS OF STANDARD CHARACTERS WITHOUT CLAIM TO ANY PARTICULAR FONT, STYLE, SIZE, OR COLOR.

FOR SHOES (U.S. CLS. 22 AND 39).
FIRST USE 4-28-2010; IN COMMERCE 4-28-2010.
EDWARD FENNESSY, EXAMINING ATTORNEY

CLASS 25—(Continued).

SN 85-448,690. JAZD-CAP, LLC, WESTLAKE, OH. FILED 10-17-2011.



OWNER OF U.S. REG. NO. 3,723,437.
NO CLAIM IS MADE TO THE EXCLUSIVE RIGHT TO USE "LIGHT", APART FROM THE MARK AS SHOWN.

THE MARK CONSISTS OF THE WORDS "THE RIGHT LIGHT ... LIGHTING THE WAY TO QUALITY CARE" WITH A STETHOSCOPE WITH A LIGHT BETWEEN THE WORDS "RIGHT AND LIGHT".

FOR CAPS AND VISORS WITH LED LIGHT ATTACHED TO BRIM (U.S. CLS. 22 AND 39).
FIRST USE 4-15-2011; IN COMMERCE 4-15-2011.
KATINA MISTER, EXAMINING ATTORNEY

SN 85-448,678. BAKAREMA, EMMANUEL, CINCINNATI, OH. AND SUAREZ, FREDDY, CINCINNATI, OH. FILED 10-17-2011.



THE MARK CONSISTS OF A CIRCULAR, SYMMETRICAL OWL LOGO.
FOR SWEATERS; T-SHIRTS (U.S. CLS. 22 AND 39).
KATINA MISTER, EXAMINING ATTORNEY

SN 85-448,784. TILLMON, CORRINA, LOS ANGELES, CA. FILED 10-17-2011.

LOVER AND FIGHTER

THE MARK CONSISTS OF STANDARD CHARACTERS WITHOUT CLAIM TO ANY PARTICULAR FONT, STYLE, SIZE, OR COLOR.

FOR ATHLETIC APPAREL, NAMELY, SHIRTS, PANTS, JACKETS, FOOTWEAR, HATS AND CAPS, ATHLETIC UNIFORMS; ATHLETIC SHOES; BATHING SUITS; BELTS; BLOUSES; BOOTS; BOXER SHORTS; CAPS; CHILDREN'S AND INFANT'S APPAREL, NAMELY, JUMPERS, OVERALL SLEEPWEAR, PAJAMAS, ROMPERS AND ONE-PIECE GARMENTS; CHILDREN'S HEADWEAR; COATS; COLLARED SHIRTS; DRESSES; FOOTWEAR FOR MEN AND WOMEN; HATS; HEAD WEAR; HEADBANDS; HOODED SWEATSHIRTS; JACKETS; JEANS; LINGERIE; NIGHTWEAR; PAJAMAS; PANTS; RAIN COATS; RAIN HATS; ROBES; SCARVES; SHIRTS AND SHORT-SLEEVED SHIRTS; SHOES; SHORTS; SKIRTS; SNEAKERS; SOCKS; SWEAT SHIRTS; SWEATERS; SWEATPANTS; SWIMWEAR; T-SHIRTS; UNDERWEAR; VESTS; WRISTBANDS (U.S. CLS. 22 AND 39).

JAMES LOVELACE, EXAMINING ATTORNEY

CLASS 25—(Continued).

SN 85-448,884. COLLINS, WILLIAM E., CINCINNATI, OH. FILED 10-17-2011.

Funk U

THE MARK CONSISTS OF STANDARD CHARACTERS WITHOUT CLAIM TO ANY PARTICULAR FONT, STYLE, SIZE, OR COLOR.

FOR ATHLETIC APPAREL, NAMELY, SHIRTS, PANTS, JACKETS, FOOTWEAR, HATS AND CAPS, ATHLETIC UNIFORMS; CAMP SHIRTS; FOOTWEAR FOR MEN AND WOMEN; HOODED SWEAT SHIRTS; T-SHIRTS (U.S. CLS. 22 AND 39).

COLLEEN DOMBROW, EXAMINING ATTORNEY

CLASS 25—(Continued).

SN 85-448,914. WILLIAM E. COLLINS, CINCINNATI, CA. FILED 10-17-2011.

Funk University

THE MARK CONSISTS OF STANDARD CHARACTERS WITHOUT CLAIM TO ANY PARTICULAR FONT, STYLE, SIZE, OR COLOR.

FOR ATHLETIC APPAREL, NAMELY, SHIRTS, PANTS, JACKETS, FOOTWEAR, HATS AND CAPS, ATHLETIC UNIFORMS; CAMP SHIRTS; HOODED SWEAT SHIRTS; T-SHIRTS (U.S. CLS. 22 AND 39).

COLLEEN DOMBROW, EXAMINING ATTORNEY

SN 85-448,894. DOMINITZ, BENZION, CINCINNATI, OH. FILED 10-17-2011.

BENADETTO CUSTOM CLOTHIERS

THE MARK CONSISTS OF STANDARD CHARACTERS WITHOUT CLAIM TO ANY PARTICULAR FONT, STYLE, SIZE, OR COLOR.

NO CLAIM IS MADE TO THE EXCLUSIVE RIGHT TO USE "CUSTOM CLOTHIERS", APART FROM THE MARK AS SHOWN.

THE WORDING "BENADETTO" HAS NO MEANING IN A FOREIGN LANGUAGE.

FOR BLOUSES; BOTTOMS; CUSTOM MADE TO MEASURE SUITS FOR MEN AND WOMEN; DRESS SUITS; FOOTWEAR; JACKETS; MEN'S SUITS, WOMEN'S SUITS; OVERCOATS; PANTS; SHIRTS; SHIRTS FOR SUITS; SHOES; SKIRTS; SUIT COATS; SUITS; SWEATERS; TIES; TOPS; TROUSERS (U.S. CLS. 22 AND 39).

DANIEL CAPSHAW, EXAMINING ATTORNEY

SN 85-448,941. PAUL ESPINO, LOS ANGELES, CA. FILED 10-17-2011.

HUMANS OVER PROFIT

SN 85-448,898. DOMINITZ, BENZION, CINCINNATI, OH. FILED 10-17-2011.

NICO CONTI

THE MARK CONSISTS OF STANDARD CHARACTERS WITHOUT CLAIM TO ANY PARTICULAR FONT, STYLE, SIZE, OR COLOR.

THE NAME(S), PORTRAIT(S), AND/OR SIGNATURE(S) SHOWN IN THE MARK DOES NOT IDENTIFY A PARTICULAR LIVING INDIVIDUAL.

FOR BLOUSES; BOTTOMS; CUSTOM MADE TO MEASURE SUITS FOR MEN AND WOMEN; DRESS SUITS; FOOTWEAR; JACKETS; MEN'S SUITS, WOMEN'S SUITS; OVERCOATS; PANTS; SHIRTS; SHIRTS FOR SUITS; SHOES; SKIRTS; SUIT COATS; SUITS; SWEATERS; TIES; TOPS; TROUSERS (U.S. CLS. 22 AND 39).

DANIEL CAPSHAW, EXAMINING ATTORNEY

THE MARK CONSISTS OF STANDARD CHARACTERS WITHOUT CLAIM TO ANY PARTICULAR FONT, STYLE, SIZE, OR COLOR.

FOR A-SHIRTS; BATHING SUITS; BEANIES; BELTS; BIKINIS; BLOUSES; BOARD SHORTS; CAMOUFLAGE JACKETS; CAMOUFLAGE SHIRTS; CARDIGANS; COATS; DENIM JACKETS; DENIMS; DOWN JACKETS; DRESS SHIRTS; DRESS SUITS; FLEECE TOPS; GOWNS; HATS; HEAD WEAR; JACKETS; JEANS; JERSEYS; LONG-SLEEVED SHIRTS; MEN'S SOCKS; PANTIES; PANTS; PARKAS; PEACOATS; RAIN HATS; RAIN JACKETS; REVERSIBLE JACKETS; SHIRTS; SHIRTS AND SHORT-SLEEVED SHIRTS; SKI SUITS; SLEEVELESS JERSEYS; SPORT SHIRTS; SPORTS JACKETS; SPORTS PANTS; SPORTS SHIRTS; T-SHIRTS (U.S. CLS. 22 AND 39).

FIRST USE 9-18-2011; IN COMMERCE 10-3-2011.

TARAH HARDY, EXAMINING ATTORNEY

CLASS 25—(Continued).

SN 85-448,970. STRAWN, LAWRENCE E., ROUND ROCK, TX. AND STRAWN, KAREN LARUE, ROUND ROCK, TX. AND VINCENTY, TRICIA LYNN, ROUND ROCK, TX. FILED 10-17-2011.



THE MARK CONSISTS OF THE CAPITALIZED LETTERS "NYAFACE" WHERE THE LETTER "N" IS LARGER THAN THE OTHER LETTERS.

FOR BANDANAS; BASEBALL CAPS; BOOTIES; GLOVES; HATS; HEADBANDS; JACKETS; JEANS; PANTS; SCARVES; SHIRTS; SHOES; SKI GLOVES; SKI MASKS; SOCKS; SWEATERS; T-SHIRTS; VISORS; WRISTBANDS (U.S. CLS. 22 AND 39).

LAURIE MAYES, EXAMINING ATTORNEY

SN 85-449,001. TRACHET, DAVID, MURFREESBORO, TN. FILED 10-17-2011.



NO CLAIM IS MADE TO THE EXCLUSIVE RIGHT TO USE "METALS" AND "CUSTOM FABRICATION", APART FROM THE MARK AS SHOWN.

THE MARK CONSISTS OF THE WORDS "BAD ASS METALS CUSTOM FABRICATION" IN A STYLIZED FONT. THE MARK IS ENCLOSED IN AN OVAL. THE WORDS "CUSTOM FABRICATION" ARE PRESENTED AT THE TOP OF THE MARK, BELOW ARE THE WORDS "BAD" AND "ASS". BELOW THE WORDS "BAD" AND "ASS" IS THE WORD "METALS". IN THE CENTER OF THE MARK IS AN IMAGE OF A DONKEY'S HEAD. CUTTING THROUGH THE EARS OF THE DONKEY ARE THE WORDS "CUSTOM FABRICATION".

FOR BUTTON DOWN SHIRTS; COATS; HOODED SWEATSHIRTS; JACKETS; LONG-SLEEVED SHIRTS; SHORTS; SWEATPANTS; SWEATSHIRTS; T-SHIRTS; TANK TOPS (U.S. CLS. 22 AND 39).

FIRST USE 11-0-2009; IN COMMERCE 11-0-2009.

JEAN IM, EXAMINING ATTORNEY

CLASS 25—(Continued).

SN 85-449,030. CALLAWAY, THOMAS, NEW YORK, NY. FILED 10-17-2011.

CEELO

THE MARK CONSISTS OF STANDARD CHARACTERS WITHOUT CLAIM TO ANY PARTICULAR FONT, STYLE, SIZE, OR COLOR.

FOR HATS; HOODED SWEATSHIRTS; SWEATSHIRTS; T-SHIRTS (U.S. CLS. 22 AND 39).

DORITT L. CARROLL, EXAMINING ATTORNEY

SN 85-449,081. GAMBY, INC., CORAL SPRINGS, FL. FILED 10-17-2011.

SLEEFS

THE MARK CONSISTS OF STANDARD CHARACTERS WITHOUT CLAIM TO ANY PARTICULAR FONT, STYLE, SIZE, OR COLOR.

FOR CLOTHING, NAMELY, ATHLETIC SLEEVES (U.S. CLS. 22 AND 39).

FIRST USE 10-1-2011; IN COMMERCE 10-15-2011.

ALEX KEAM, EXAMINING ATTORNEY

SN 85-449,158. COLUMBIA SPORTSWEAR NORTH AMERICA, INC., PORTLAND, OR. FILED 10-17-2011.

OMNI-WIND

THE MARK CONSISTS OF STANDARD CHARACTERS WITHOUT CLAIM TO ANY PARTICULAR FONT, STYLE, SIZE, OR COLOR.

OWNER OF U.S. REG. NOS. 3,878,153, 3,954,825 AND OTHERS.

FOR BALACLAVAS; GLOVES; HEADBANDS; HEADWEAR; JACKETS; NECK GAITERS; PARKAS (U.S. CLS. 22 AND 39).

SUNG IN, EXAMINING ATTORNEY

CLASS 25—(Continued).

SN 85-449,163. JOSEPH ADAMS, BRIGHTON, IL. FILED 10-17-2011.

HARDWOOD JOE'S APPARELS

THE MARK CONSISTS OF STANDARD CHARACTERS WITHOUT CLAIM TO ANY PARTICULAR FONT, STYLE, SIZE, OR COLOR.

NO CLAIM IS MADE TO THE EXCLUSIVE RIGHT TO USE "APPARELS", APART FROM THE MARK AS SHOWN. FOR WEARABLE GARMENTS AND CLOTHING, NAMELY, SHIRTS (U.S. CLS. 22 AND 39).

KATHERINE CONNOLLY, EXAMINING ATTORNEY

SN 85-449,200. HICKS, JOSH, LOUISVILLE, KY. FILED 10-17-2011.

BOAT UP

THE MARK CONSISTS OF STANDARD CHARACTERS WITHOUT CLAIM TO ANY PARTICULAR FONT, STYLE, SIZE, OR COLOR.

FOR CLOTHING, NAMELY, TOPS, BOTTOMS, T-SHIRTS, HATS, CAPS, UNDERWEAR, SWEATSHIRTS, SHORTS, BEANIES (U.S. CLS. 22 AND 39).

TASNEEM HUSSAIN, EXAMINING ATTORNEY

SN 85-449,307. CRUZ, WALTER, SAN PABLO, CA. FILED 10-17-2011.

SELF MOTIVATED CLOTHING

THE MARK CONSISTS OF STANDARD CHARACTERS WITHOUT CLAIM TO ANY PARTICULAR FONT, STYLE, SIZE, OR COLOR.

NO CLAIM IS MADE TO THE EXCLUSIVE RIGHT TO USE "CLOTHING", APART FROM THE MARK AS SHOWN. FOR CLOTHING, NAMELY, FOOTWEAR, HEADWEAR, TOPS, BOTTOMS, SHIRTS, AND PANTS (U.S. CLS. 22 AND 39).

MAYUR VAGHANI, EXAMINING ATTORNEY

CLASS 25—(Continued).

SN 85-449,378. CARPELO JEBOAM, COCONUT CREEK, FL. FILED 10-17-2011.

isticktoit!

THE MARK CONSISTS OF STANDARD CHARACTERS WITHOUT CLAIM TO ANY PARTICULAR FONT, STYLE, SIZE, OR COLOR.

FOR APPAREL FOR DANCERS, NAMELY, TEE SHIRTS, SWEATSHIRTS, PANTS, LEGGINGS, SHORTS AND JACKETS; ATHLETIC APPAREL, NAMELY, SHIRTS, PANTS, JACKETS, HATS AND CAPS, ATHLETIC UNIFORMS; CHILDREN'S AND INFANT'S APPAREL, NAMELY, JUMPERS, OVERALL SLEEPWEAR, PAJAMAS, ROMPERS AND ONE-PIECE GARMENTS; CHILDREN'S AND INFANTS' APPAREL TREATED WITH FIRE AND HEAT RETARDANTS, NAMELY, JUMPERS, OVERALL SLEEPWEAR, PAJAMAS, ROMPERS AND ONE-PIECE GARMENTS; GLOVES FOR APPAREL; SCIENTIFIC AND TECHNOLOGICAL APPAREL, NAMELY, SHIRTS, PANTS, JACKETS, HATS AND CAPS, UNIFORMS (U.S. CLS. 22 AND 39).

FIRST USE 12-16-2009; IN COMMERCE 3-18-2011.

JENNIFER WILLISTON, EXAMINING ATTORNEY

SN 85-449,390. ELITE AGENTS LLC, BROOKLYN, NY. FILED 10-17-2011.



THE MARK CONSISTS OF THE WORDING "COMMUNITY 54". THE LETTER "O" IN "COMMUNITY" IS IN THE SHAPE OF A LION'S HEAD AND THE LETTERS "UNITY" IN THE WORD "COMMUNITY" ARE UNDERLINED. THE WORD "COMMUNITY" APPEARS ON TOP OF THE NUMBER "54".

FOR ATHLETIC APPAREL, NAMELY, SHIRTS, PANTS, JACKETS, FOOTWEAR, HATS AND CAPS, ATHLETIC UNIFORMS; ATHLETIC FOOTWEAR; ATHLETIC SHOES; ATHLETIC UNIFORMS; BELTS; BELTS FOR CLOTHING; BELTS MADE OUT OF CLOTH; BOTTOMS; CLOTHING, NAMELY, KHAKIS; FOOTWEAR FOR TRACK AND FIELD ATHLETICS; GLOVES AS CLOTHING; HEADBANDS FOR CLOTHING; HOODS; JACKETS; JERSEYS; LEATHER BELTS; POCKET SQUARES; SHORT SETS; SHOULDER WRAPS; SHOULDER WRAPS FOR CLOTHING; TIES; TOPS; TRAVEL CLOTHING CONTAINED IN A PACKAGE COMPRISING REVERSIBLE JACKETS, PANTS, SKIRTS, TOPS AND A BELT OR SCARF; WEARABLE GARMENTS AND CLOTHING, NAMELY, SHIRTS; WOMEN'S CLOTHING, NAMELY, SHIRTS, DRESSES, SKIRTS, BLOUSES (U.S. CLS. 22 AND 39).

ANDREW RHIM, EXAMINING ATTORNEY

CLASS 25—(Continued).

SN 85-449,433. PATTON, MARCUS, LOS ANGELES, CA. FILED 10-18-2011.

WOOF MONKEY

THE MARK CONSISTS OF STANDARD CHARACTERS WITHOUT CLAIM TO ANY PARTICULAR FONT, STYLE, SIZE, OR COLOR.

FOR CLOTHING, NAMELY, T-SHIRTS, PANTS, SHORTS, TOPS, BOTTOMS, HATS, JACKETS (U.S. CLS. 22 AND 39).

WILLIAM VERHOSEK, EXAMINING ATTORNEY

SN 85-449,457. DISTLER, ROBERT, GILBERT, AZ. FILED 10-18-2011.

HESSIAN AGGRESSION

THE MARK CONSISTS OF STANDARD CHARACTERS WITHOUT CLAIM TO ANY PARTICULAR FONT, STYLE, SIZE, OR COLOR.

FOR HATS; SHIRTS (U.S. CLS. 22 AND 39).
WILLIAM VERHOSEK, EXAMINING ATTORNEY

SN 85-449,535. SMITH, STACEY D., BUFFALO, NY. FILED 10-18-2011.



THE MARK CONSISTS OF A CIRCLE CONTAINING A PAIR OF SHOES IN FRONT OF STACKS OF DOLLAR BILLS. ENCLOSED IN A BANNER ABOVE THE CIRCLE IS THE STYLIZED TEXT "STACKS AND KICKS". BELOW THE CIRCLE IS AN ABSTRACT WING DESIGN MADE UP OF 17 DIFFERENT SHAPES ARRANGED IN A PATTERN.

FOR HATS; HOODED SWEAT SHIRTS; SCARVES; SWEATBANDS; SWEATPANTS; T-SHIRTS (U.S. CLS. 22 AND 39).

CURTIS FRENCH, EXAMINING ATTORNEY

CLASS 25—(Continued).

SN 85-449,552. ALNALDO GONZALEZ, NORTH BAY VILLAGE, FL. FILED 10-18-2011.



THE MARK CONSISTS OF AN UPSIDE DOWN "U" THAT CREATES AN OPEN DOME SHAPE WITH A "S" INSIDE OF IT. BELOW THE DOME SHAPE, THE WORDS "URBAN SOCIETY" ARE WRITTEN. THE "U" IS UPSIDE DOWN. THE "U" AND "S" ARE CAPITALIZED AND THE OTHER LETTERS ARE IN LOWERCASE.

FOR CLOTHING NAMELY, SWEATERS, JACKETS, HATS, HOODED SWEATERS, LONG SLEEVE SHIRTS AND SHORT SLEEVE SHIRTS, TANK TOPS, JEANS, SHORTS, SOCKS, SNEAKERS (U.S. CLS. 22 AND 39).

REBECCA GILBERT, EXAMINING ATTORNEY

SN 85-449,596. RIMAN, JEFFREY, PLANTATION, FL. FILED 10-18-2011.

Hellbourne

THE MARK CONSISTS OF STANDARD CHARACTERS WITHOUT CLAIM TO ANY PARTICULAR FONT, STYLE, SIZE, OR COLOR.

FOR CLOTHING FOR MEN AND WOMEN, NAMELY TEE SHIRTS, DRESS SHIRTS, SWEATSHIRTS, SWEATERS, PANTS, JEANS, SWEATPANTS, CARGO PANTS, CARGO SHORTS, BOARD SHORTS, DRESSES, HATS, CAPS, SCARVES, AND UNDERGARMENTS (U.S. CLS. 22 AND 39).

MICHELE SWAIN, EXAMINING ATTORNEY

SN 85-449,612. GRIMES, DARRELL, NEW ROSS, IN. FILED 10-18-2011.

CHUBB\$WEAR

THE MARK CONSISTS OF THE STYLIZED TEXT "CHUBB\$WEAR".

FOR HATS; SWEATSHIRTS; UNDERWEAR (U.S. CLS. 22 AND 39).

ODESSA BIBBINS, EXAMINING ATTORNEY

CLASS 25—(Continued).

SN 85-449,657. CULVER, KEITH, ORANGE, CA. FILED 10-18-2011.

Union Thread

THE MARK CONSISTS OF STANDARD CHARACTERS WITHOUT CLAIM TO ANY PARTICULAR FONT, STYLE, SIZE, OR COLOR.

FOR DENIMS; HEADWEAR; HOODED PULLOVERS; HOODED SWEAT SHIRTS; JACKETS; T-SHIRTS; TANK TOPS; WOVEN BOTTOMS; WOVEN TOPS (U.S. CLS. 22 AND 39).

HANNO RITTNER, EXAMINING ATTORNEY

CLASS 25—(Continued).

SN 85-449,776. GLOBAL TRADEMARKS, INC., STOCKERTOWN, PA. FILED 10-18-2011.

BAL HARBOUR SWIM

THE MARK CONSISTS OF STANDARD CHARACTERS WITHOUT CLAIM TO ANY PARTICULAR FONT, STYLE, SIZE, OR COLOR.

NO CLAIM IS MADE TO THE EXCLUSIVE RIGHT TO USE "SWIM", APART FROM THE MARK AS SHOWN.

FOR SWIMWEAR (U.S. CLS. 22 AND 39).
CHRISTINA SOBRAL, EXAMINING ATTORNEY

SN 85-449,675. ALLEN, MARCUS, UNION, NJ. FILED 10-18-2011.

Footables it ain't just socks

THE MARK CONSISTS OF STANDARD CHARACTERS WITHOUT CLAIM TO ANY PARTICULAR FONT, STYLE, SIZE, OR COLOR.

FOR SOCKS (U.S. CLS. 22 AND 39).
LINDA MICKLEBURGH, EXAMINING ATTORNEY

SN 85-449,857. SLYDZ, LLC, YORK, PA. FILED 10-18-2011.

SLYDZ GEAR

THE MARK CONSISTS OF STANDARD CHARACTERS WITHOUT CLAIM TO ANY PARTICULAR FONT, STYLE, SIZE, OR COLOR.

NO CLAIM IS MADE TO THE EXCLUSIVE RIGHT TO USE "GEAR", APART FROM THE MARK AS SHOWN.

FOR CLOTHING, NAMELY, DENIMS (U.S. CLS. 22 AND 39).
JOHN HWANG, EXAMINING ATTORNEY

SN 85-449,677. COLEMAN, VALARIE, LOS ANGELES, CA. FILED 10-18-2011.

Flirty Feet

THE MARK CONSISTS OF STANDARD CHARACTERS WITHOUT CLAIM TO ANY PARTICULAR FONT, STYLE, SIZE, OR COLOR.

FOR FLIP FLOP SANDALS (U.S. CLS. 22 AND 39).
WILLIAM JACKSON, EXAMINING ATTORNEY

SN 85-449,876. GAO, RONG RONG, SHANG HAI, CHINA, FILED 10-18-2011.

PRINCE LUCAS

THE MARK CONSISTS OF STANDARD CHARACTERS WITHOUT CLAIM TO ANY PARTICULAR FONT, STYLE, SIZE, OR COLOR.

THE NAME(S), PORTRAIT(S), AND/OR SIGNATURE(S) SHOWN IN THE MARK DOES NOT IDENTIFY A PARTICULAR LIVING INDIVIDUAL.

FOR DRESS SHIRTS; DRESS SUITS; SHIRTS; SUITS (U.S. CLS. 22 AND 39).
JEFFREY LOOK, EXAMINING ATTORNEY

CLASS 25—(Continued).

SN 85-449,879. SLYDZ, LLC, YORK, PA. FILED 10-18-2011.

SLYDZ CARD

THE MARK CONSISTS OF STANDARD CHARACTERS WITHOUT CLAIM TO ANY PARTICULAR FONT, STYLE, SIZE, OR COLOR.

NO CLAIM IS MADE TO THE EXCLUSIVE RIGHT TO USE "CARD", APART FROM THE MARK AS SHOWN.

FOR FABRIC INSERTS SOLD AS AN INTEGRAL COMPONENT OF FINISHED CLOTHING ITEMS, NAMELY, DENIMS (U.S. CLS. 22 AND 39).

JOHN HWANG, EXAMINING ATTORNEY

SN 85-449,910. GAO, RONG RONG, SHANG HAI, CHINA, FILED 10-18-2011.

PRINCE MILES

THE MARK CONSISTS OF STANDARD CHARACTERS WITHOUT CLAIM TO ANY PARTICULAR FONT, STYLE, SIZE, OR COLOR.

THE NAME(S), PORTRAIT(S), AND/OR SIGNATURE(S) SHOWN IN THE MARK DOES NOT IDENTIFY A PARTICULAR LIVING INDIVIDUAL.

FOR DRESS SHIRTS; DRESS SUITS; SHIRTS; SUITS (U.S. CLS. 22 AND 39).

JEFFREY LOOK, EXAMINING ATTORNEY

SN 85-449,963. MARKHAM, CLYDE LESLIE, III, VIERA, FL. FILED 10-18-2011.

DRAGON'S BACK

THE MARK CONSISTS OF STANDARD CHARACTERS WITHOUT CLAIM TO ANY PARTICULAR FONT, STYLE, SIZE, OR COLOR.

FOR CAPS; HOODED SWEATSHIRTS; T-SHIRTS; WETSUITS (U.S. CLS. 22 AND 39).

JILL PRATER, EXAMINING ATTORNEY

CLASS 25—(Continued).

SN 85-450,025. RANDELL, MARTHA R, DBA SOCK PALS, TALLAHASSEE, FL. FILED 10-18-2011.

Baby's First Friend

THE MARK CONSISTS OF STANDARD CHARACTERS WITHOUT CLAIM TO ANY PARTICULAR FONT, STYLE, SIZE, OR COLOR.

NO CLAIM IS MADE TO THE EXCLUSIVE RIGHT TO USE "BABY'S", APART FROM THE MARK AS SHOWN.

FOR SOCKS (U.S. CLS. 22 AND 39).

LINDA E. BLOHM, EXAMINING ATTORNEY

SN 85-450,124. SOUTHERN MARSH COLLECTION, LLC, BATON ROUGE, LA. FILED 10-18-2011.

FIELDTEC

THE MARK CONSISTS OF STANDARD CHARACTERS WITHOUT CLAIM TO ANY PARTICULAR FONT, STYLE, SIZE, OR COLOR.

FOR CLOTHING, NAMELY, TOPS, BOTTOMS, JACKETS, PARKAS, COATS, PANTS, BIB OVERALL PANTS, VESTS, ONE-PIECE SHELL SUITS, SHELLS, MITTENS, GLOVES, HATS, RAINWEAR, WIND RESISTANT JACKETS, SHORTS, SHIRTS, T-SHIRTS, THERMAL UNDERWEAR, AND SWEATERS; BOOTS, NAMELY, HIKING AND TREKKING BOOTS; SHOES, NAMELY, CLIMBING, HIKING, TRAIL RUNNING, ATHLETIC, SNEAKERS, AND SLIPPERS, AND CLIMBING SLIPPERS (U.S. CLS. 22 AND 39).

FIRST USE 6-13-2011; IN COMMERCE 9-12-2011.

STEVEN JACKSON, EXAMINING ATTORNEY

SN 85-450,135. ROBERTSON, STEVE, EKRON, KY. AND ZDENEK, JESSE, MOBILE, AL. FILED 10-18-2011.

TRASHY BASTARD

THE MARK CONSISTS OF STANDARD CHARACTERS WITHOUT CLAIM TO ANY PARTICULAR FONT, STYLE, SIZE, OR COLOR.

FOR HATS; JACKETS; SHIRTS (U.S. CLS. 22 AND 39).

KAPIL BHANOT, EXAMINING ATTORNEY

CLASS 25—(Continued).

SN 85-450,151. GAZEBO PUBLICATIONS LLC, FORT LAUDERDALE, FL. FILED 10-18-2011.



THE MARK CONSISTS OF AN OCTAGON WITHIN WHICH APPEARS EIGHT OCTAGONS TOUCHING EACH OTHER FORMING AN IRREGULAR DIAMOND SHAPE AND WITHIN THE EIGHT OCTAGONS IS AN IRREGULARLY SHAPED DIAMOND WITH FOUR SQUARES APPEARING ON THE OUTSIDE OF THE DIAMOND.

FOR CLOTHING, NAMELY, FOOTWEAR, HEADWEAR, TOPS, BOTTOMS, SHIRTS, POLO SHIRTS, T-SHIRTS, SWEAT SHIRTS, SWEATERS, JACKETS, AND PANTS (U.S. CLS. 22 AND 39).

EDWARD NELSON, EXAMINING ATTORNEY

SN 85-450,182. CALLAWAY, THOMAS, NEW YORK, NY. FILED 10-18-2011.

CeeLo Green

THE MARK CONSISTS OF STANDARD CHARACTERS WITHOUT CLAIM TO ANY PARTICULAR FONT, STYLE, SIZE, OR COLOR.

FOR HATS; HOODED SWEATSHIRTS; SWEATSHIRTS; T-SHIRTS (U.S. CLS. 22 AND 39).

DORITT L. CARROLL, EXAMINING ATTORNEY

CLASS 25—(Continued).

SN 85-450,207. ASHWORTH, LLC, CARLSBAD, CA. FILED 10-18-2011.

THE COURSE NEVER LEAVES YOU

THE MARK CONSISTS OF STANDARD CHARACTERS WITHOUT CLAIM TO ANY PARTICULAR FONT, STYLE, SIZE, OR COLOR.

FOR FOOTWEAR; SHORTS, PANTS, SKIRTS, SKORTS, DRESSES, SHIRTS, TOPS, VESTS, JERSEYS, UNIFORMS, SWEATERS, SWEATSHIRTS, PULLOVERS, BLAZERS, COATS, JACKETS, TRACK SUITS, TRAINING SUITS, JUMP SUITS, WARM-UP SUITS, RAINWEAR, SKI SUITS, BODYSUITS, SWIMWEAR, UNDERWEAR, SLEEPWEAR, TIGHTS, STOCKINGS, SOCKS, GLOVES, MITTENS, SCARVES, TIES, WRISTBANDS, BELTS; CAPS, HATS, VISORS, HEADBANDS (U.S. CLS. 22 AND 39).

TRACY FLETCHER, EXAMINING ATTORNEY

SN 85-450,237. KEVIN AVERY, FORT WORTH, TX. FILED 10-18-2011.

DARE DOGS

THE MARK CONSISTS OF STANDARD CHARACTERS WITHOUT CLAIM TO ANY PARTICULAR FONT, STYLE, SIZE, OR COLOR.

FOR CAPS; CLOTHING, NAMELY, BASE LAYERS; CLOTHING, NAMELY, CROPS; CLOTHING, NAMELY, KHAKIS; GLOVES; HATS; HEADBANDS; HOODED PULLOVERS; JACKETS; LONG-SLEEVED SHIRTS; PANTS; SHIRTS; SHORTS; SOCKS; SWEATSHIRTS; T-SHIRTS; TANK-TOPS (U.S. CLS. 22 AND 39).

SALLY SHIH, EXAMINING ATTORNEY

SN 85-450,284. HAIDOUS, BILAL, CERRITOS, CA. FILED 10-18-2011.

Oblivious

THE MARK CONSISTS OF STANDARD CHARACTERS WITHOUT CLAIM TO ANY PARTICULAR FONT, STYLE, SIZE, OR COLOR.

FOR CLOTHING, NAMELY, T-SHIRTS, SHIRTS, TANK TOPS, DENIM PANTS, SHORTS, JACKETS, SWEATSHIRTS, HOODED SWEATSHIRT, DRESS PANTS, DRESS SHIRTS, SURF SHORTS, BEANIES, HATS, BELTS, SHOES (U.S. CLS. 22 AND 39).

JOHN WILKE, EXAMINING ATTORNEY

CLASS 25—(Continued).

SN 85-450,298. WOLVERINE FOOTBALL ALUMNI ASSOCIATION, NORTH VERSAILLES, PA. FILED 10-18-2011.

Swthag

THE MARK CONSISTS OF STANDARD CHARACTERS WITHOUT CLAIM TO ANY PARTICULAR FONT, STYLE, SIZE, OR COLOR.

FOR JACKETS; SWEATSHIRTS; T-SHIRTS (U.S. CLS. 22 AND 39).

JILL C. ALT, EXAMINING ATTORNEY

SN 85-450,342. HAIDOUS, BILAL, CERRITOS, CA. FILED 10-18-2011.

Soul Arch

THE MARK CONSISTS OF STANDARD CHARACTERS WITHOUT CLAIM TO ANY PARTICULAR FONT, STYLE, SIZE, OR COLOR.

FOR CLOTHING, NAMELY, T-SHIRTS SHIRTS, SWEATSHIRTS, DENIM PANTS, TWILL PANTS, DENIM SHORTS, TWILL SHORTS, SURF SHORTS, DENIM SHIRTS, DRESS SHIRTS AND HATS (U.S. CLS. 22 AND 39).

JOHN WILKE, EXAMINING ATTORNEY

SN 85-450,343. THOMAS REAY, NEW HAVEN, MO. FILED 10-18-2011.

intertwined swine

THE MARK CONSISTS OF STANDARD CHARACTERS WITHOUT CLAIM TO ANY PARTICULAR FONT, STYLE, SIZE, OR COLOR.

FOR SHIRTS; SHORT-SLEEVED OR LONG-SLEEVED T-SHIRTS; T-SHIRTS (U.S. CLS. 22 AND 39).

NAPOLEON SHARMA, EXAMINING ATTORNEY

CLASS 25—(Continued).

SN 85-450,357. TOWNSEL, DOROTHY, MEMPHIS, TN. FILED 10-18-2011.



THE MARK CONSISTS OF TWO CONCENTRIC VERTICAL OVALS WITH THE LETTERS "ISNS" IN LARGE FONT ACROSS THE CENTER, THE WORDS "I'M SOMEBODY, NOT SOME-BODY" IN BOLD PRINT AROUND THE TOP HALF OF THE OVAL DESIGN, AND THE WORDS "MY MIND IS MY GREATEST ASSET" IN BOLD PRINT AROUND THE BOTTOM HALF OF THE OVAL DESIGN.

FOR HATS; SLEEPWEAR; T-SHIRTS (U.S. CLS. 22 AND 39).

WILLIAM JACKSON, EXAMINING ATTORNEY

SN 85-450,493. ZHEJIANG DONGJIA KNITTING CO., LTD., ZHUJI CITY, CHINA, FILED 10-18-2011.



THE MARK CONSISTS OF THE STYLIZED WORDING "DONGJIA" WITH AN IMAGE OF A BUTTERFLY ABOVE THE LETTERS "DO", AND ABOVE THIS WORDING IS A STYLIZED IMAGE OF A PERSON STANDING INSIDE A TRIANGLE IN WHICH THE BOTTOM OF THE TRIANGLE IS A WAVY LINE.

THE WORDING "DONGJIA" HAS NO MEANING IN A FOREIGN LANGUAGE.

FOR BABY LAYETTES FOR CLOTHING; COATS; GLOVES; HATS; HOSIERY; MEN'S AND WOMEN'S JACKETS, COATS, TROUSERS, VESTS; NECKTIES; SHAWLS AND HEADSCARVES; SHOES; SOCKS; SWIM SUITS; WATERPROOF JACKETS AND PANTS; WOMEN'S CLOTHING, NAMELY, SHIRTS, DRESSES, SKIRTS, BLOUSES (U.S. CLS. 22 AND 39).

FIRST USE 8-15-1990; IN COMMERCE 7-13-2011.

JOHN DWYER, EXAMINING ATTORNEY

CLASS 25—(Continued).

SN 85-450,628. BURTON, CURTIS, LOS ANGELES, CA. FILED 10-19-2011.

i tested positive for christ
some times stressed but
always blessed

THE MARK CONSISTS OF STANDARD CHARACTERS WITHOUT CLAIM TO ANY PARTICULAR FONT, STYLE, SIZE, OR COLOR.

FOR DRESSES; HATS; SHORTS; SWEATSHIRTS; T-SHIRTS (U.S. CLS. 22 AND 39).

MIDGE BUTLER, EXAMINING ATTORNEY

SN 85-451,545. FIFTH STREET GAMING, LLC, LAS VEGAS, NV. FILED 10-19-2011.

DOWNTOWN GRAND

THE MARK CONSISTS OF STANDARD CHARACTERS WITHOUT CLAIM TO ANY PARTICULAR FONT, STYLE, SIZE, OR COLOR.

FOR ATHLETIC SHOES; BATHING SUITS; BEACH COVER-UPS; BELTS; BLAZERS; BLOUSES; BOOTIES; BOOTS; CAPS; FOOTWEAR; GLOVES; GOLF SHIRTS; HATS; HEADBANDS; HEADWEAR; HOSIERY; JACKETS; JEANS; JERSEYS; JOGGING SUITS; LEOTARDS; MITTENS; NECKTIES; NIGHTGOWNS; NIGHTSHIRTS; PAJAMA BOTTOMS; PAJAMAS; PANTS; PARKAS; POLO SHIRTS; PULLOVERS; RAIN WEAR; ROBES; ROMPERS; SANDALS AND BEACH SHOES; SCARVES; SHIRTS; SHOES; SHORTS; SKIRTS; SLACKS; SLIPPERS; SNEAKERS; SOCKS; SUSPENDERS; SWEAT PANTS; SWEAT SHIRTS; SWEATERS; SWIMSUITS; T-SHIRTS; TANK-TOPS; TURTLENECKS; UNDERGARMENTS; VESTS; VISORS; WARM UP SUITS; WIND RESISTANT JACKETS (U.S. CLS. 22 AND 39).

DAVID HOFFMAN, EXAMINING ATTORNEY

CLASS 25—(Continued).

SN 85-451,553. HANNA-BARBERA PRODUCTIONS, INC., BURBANK, CA. FILED 10-19-2011.



THE MARK CONSISTS OF DRAWING OF A SMILING BEAR'S HEAD WITH A BOW TIE AT THE NECK WITH THE VERBIAGE "BOO BOO" BELOW THE BEAR'S HEAD.

FOR CLOTHING FOR MEN, WOMEN AND CHILDREN, NAMELY, SHIRTS, T-SHIRTS, SWEATSHIRTS, JOGGING SUITS, TROUSERS, PANTS, SHORTS, TANK TOPS, RAINWEAR, CLOTH BABY BIBS, SKIRTS, BLOUSES, DRESSES, SUSPENDERS, SWEATERS, JACKETS, COATS, RAINCOATS, SNOW SUITS, TIES, ROBES, HATS, CAPS, SUN VISORS, BELTS, SCARVES, SLEEPWEAR, PAJAMAS, LINGERIE, UNDERWEAR, BOOTS, SHOES, SNEAKERS, SANDALS, SOCKS, BOOTIES, SLIPPER SOCKS, SWIMWEAR AND MASQUERADE AND HALLOWEEN COSTUMES AND MASKS SOLD IN CONNECTION THEREWITH (U.S. CLS. 22 AND 39).

NATALIE POLZER, EXAMINING ATTORNEY

SN 85-451,878. JOCKEY INTERNATIONAL, INC., KENOSHA, WI. FILED 10-20-2011.

GIVE DRY A TRY

THE MARK CONSISTS OF STANDARD CHARACTERS WITHOUT CLAIM TO ANY PARTICULAR FONT, STYLE, SIZE, OR COLOR.

FOR UNDERWEAR TOPS AND BOTTOMS; PANTIES; CAMISOLES; TANKS; BRAS; SOCKS; HOSIERY; LONG UNDERWEAR; ACTIVEWEAR, NAMELY, TOPS AND BOTTOMS, BRAS, TANKS, T-SHIRTS, PANTS, SHORTS AND JACKETS; SPORTSWEAR, NAMELY, TOPS AND BOTTOMS, BRAS, TANKS, T-SHIRTS, PANTS, SHORTS AND JACKETS; SLEEPWEAR; SHAPEWEAR, NAMELY, TOPS AND BOTTOMS, TANKS, CAMISOLES, SLIPS AND BODYSUITS; AND THERMAL UNDERWEAR TOPS AND BOTTOMS (U.S. CLS. 22 AND 39).

WILLIAM ROSSMAN, EXAMINING ATTORNEY

CLASS 25—(Continued).

SN 85-452,685. TWENTIETH CENTURY FOX FILM CORPORATION, LOS ANGELES, CA. FILED 10-20-2011.

CON GARRA

THE MARK CONSISTS OF STANDARD CHARACTERS WITHOUT CLAIM TO ANY PARTICULAR FONT, STYLE, SIZE, OR COLOR.

THE ENGLISH TRANSLATION OF "CON GARRA" IN THE MARK IS "PUNCHY".

FOR SHIRTS; PANTS; SHORTS; UNDERWEAR; BOXER SHORTS; HATS; CAPS; SWEATSHIRTS; SWEATERS; SKIRTS; GLOVES; SOCKS; SHOES; BOOTS; COATS; JACKETS; SWIMWEAR; BELTS; SCARVES; PAJAMAS; SLIPPERS; INFANT WEAR; HOSIERY; HALLOWEEN AND MASQUERADE COSTUMES AND MASKS SOLD IN CONNECTION THEREWITH; TIES (U.S. CLS. 22 AND 39).

JANICE L. MCMORROW, EXAMINING ATTORNEY

SN 85-453,425. SILVER STAR MERCHANDISING, LTD., IRVING, TX. FILED 10-21-2011.

289c Apparel

THE MARK CONSISTS OF STANDARD CHARACTERS WITHOUT CLAIM TO ANY PARTICULAR FONT, STYLE, SIZE, OR COLOR.

NO CLAIM IS MADE TO THE EXCLUSIVE RIGHT TO USE "APPAREL", APART FROM THE MARK AS SHOWN.

FOR CLOTHING FOR MEN, WOMEN AND CHILDREN, NAMELY, SHIRTS, SHORTS, PANTS, JACKETS, JERSEYS, SWEAT SUITS, SWEAT SHIRTS, SWEAT PANTS, FLEECE TOPS AND BOTTOMS, JERSEYS, PAJAMAS, WIND SUITS, COATS, PONCHOS, GLOVES, SOCKS, UNDERWEAR AND HEADWEAR (U.S. CLS. 22 AND 39).

ANGELA M. MICHELI, EXAMINING ATTORNEY

SN 85-454,227. H & H PRINTING, GRENADA, MS. FILED 10-24-2011.



THE MARK CONSISTS OF THE WORDS: "BRING YOUR GAME FACE". THE WORDS "BRING YOUR" IN ALL CAPS POSITIONED ABOVE THE WORD "GAME" IN ALL CAPS, AND THE WORD FACE IN LOWERCASE LETTERS. DEER ANTLERS ARE POSITIONED ABOVE THE WORD "FACE".

FOR T-SHIRTS (U.S. CLS. 22 AND 39).

ALEXANDER L. POWERS, EXAMINING ATTORNEY

CLASS 25—(Continued).

SN 85-454,251. H & H PRINTING, GRENADA, MS. FILED 10-24-2011.



THE MARK CONSISTS OF THE WORDS: "BRING YOUR GAME FACE". THE WORDS "BRING YOUR" IN ALL CAPS ABOVE THE WORD "GAME", AN IMAGE OF THREE DUCKS FLYING OVER THE WORD "FACE" IN ALL LOWER CASE LETTERS.

FOR T-SHIRTS (U.S. CLS. 22 AND 39).

ALEXANDER L. POWERS, EXAMINING ATTORNEY

SN 85-454,301. H & H PRINTING, GRENADA, MS. FILED 10-24-2011.



THE MARK CONSISTS OF THE WORDS: "BRING YOUR GAME FACE" WITH THE WORDS "BRING YOUR" IN ALL CAPS ABOVE THE WORD "GAME", AN IMAGE OF A TENNIS BALL, TENNIS RACQUET, FOOTBALL, SOFTBALL, BASKETBALL, AND SOCCER BALL ABOVE THE WORD "FACE" IN ALL LOWER CASE LETTERS.

FOR T-SHIRTS (U.S. CLS. 22 AND 39).

ALEXANDER L. POWERS, EXAMINING ATTORNEY

SN 85-457,506. HAIDOUS, BILAL, CERRITOS, CA. FILED 10-27-2011.

Antitrust

THE MARK CONSISTS OF STANDARD CHARACTERS WITHOUT CLAIM TO ANY PARTICULAR FONT, STYLE, SIZE, OR COLOR.

FOR CLOTHING, NAMELY, T-SHIRTS SHIRTS, SWEATSHIRTS, DENIM PANTS, TWILL PANTS, DENIM SHORTS, TWILL SHORTS, SURF SHORTS, DENIM SHIRTS, DRESS SHIRTS, HATS, SHOES (U.S. CLS. 22 AND 39).

JOHN WILKE, EXAMINING ATTORNEY

CLASS 25—(Continued).

SN 85-457,976. JNS GLOBAL TRADING, INC., RICHMOND HILL, NY. FILED 10-27-2011.



THE MARK CONSISTS OF STYLIZED LETTERS "JNS GLOBAL" WITH "JNS" APPEARING IN A CIRCULAR DESIGN AND "GLOBAL" APPEARING RIGHT UNDER IT. FOR ATHLETIC APPAREL, NAMELY, SHIRTS, PANTS, JACKETS, FOOTWEAR, HATS AND CAPS, ATHLETIC UNIFORMS; BERMUDA SHORTS; BOMBER JACKETS; BOXER SHORTS; BUTTON DOWN SHIRTS; DENIM JACKETS; DRESS SHIRTS; GYM SHORTS; MEN'S AND WOMEN'S JACKETS, COATS, TROUSERS, VESTS; OUTER JACKETS; SHORTS; SWEAT JACKETS; SWEAT SHORTS; T-SHIRTS; TRACK JACKETS; WALKING SHORTS (U.S. CLS. 22 AND 39).
FIRST USE 11-26-2011; IN COMMERCE 11-26-2011.
FRANK LATTUCA, EXAMINING ATTORNEY

SN 85-458,027. SRL, LLC, LEXINGTON, MA. FILED 10-27-2011.

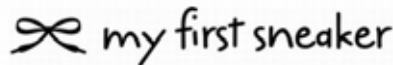

NO CLAIM IS MADE TO THE EXCLUSIVE RIGHT TO USE "SNEAKER", APART FROM THE MARK AS SHOWN. THE MARK CONSISTS OF A SHOE LACE TIED IN A BOW FOLLOWED BY LOWER CASE "MY FIRST SNEAKER". FOR FOOTWEAR (U.S. CLS. 22 AND 39).
CHRISTINA SOBRAL, EXAMINING ATTORNEY

SN 85-458,325. HEROIC RACING APPAREL, LLC, OAKLAND GARDENS, NY. FILED 10-27-2011.



THE MARK CONSISTS OF STANDARD CHARACTERS WITHOUT CLAIM TO ANY PARTICULAR FONT, STYLE, SIZE, OR COLOR.
OWNER OF U.S. REG. NO. 3,645,590.
FOR FOOTWEAR (U.S. CLS. 22 AND 39).
ALEX KEAM, EXAMINING ATTORNEY

CLASS 25—(Continued).

SN 85-458,708. MACY'S MERCHANDISING GROUP, INC., NEW YORK, NY. FILED 10-28-2011.



THE MARK CONSISTS OF STANDARD CHARACTERS WITHOUT CLAIM TO ANY PARTICULAR FONT, STYLE, SIZE, OR COLOR.
FOR CLOTHING, NAMELY, JACKETS AND COATS (U.S. CLS. 22 AND 39).
FIRST USE 8-31-2006; IN COMMERCE 8-31-2006.
SIMON TENG, EXAMINING ATTORNEY

SN 85-458,959. NIELSEN, MARKUS JAMES, SAN DIEGO, CA. FILED 10-28-2011.

BAMBOO & DIAMONDS

THE MARK CONSISTS OF STANDARD CHARACTERS WITHOUT CLAIM TO ANY PARTICULAR FONT, STYLE, SIZE, OR COLOR.
NO CLAIM IS MADE TO THE EXCLUSIVE RIGHT TO USE "BAMBOO", APART FROM THE MARK AS SHOWN.
FOR A-SHIRTS; ADHESIVE BRAS; ANKLE SOCKS; ATHLETIC APPAREL, NAMELY, SHIRTS, PANTS, JACKETS, FOOTWEAR, HATS AND CAPS, ATHLETIC UNIFORMS; ATHLETIC FOOTWEAR; ATHLETIC SHOES; ATHLETIC TIGHTS; BABY BODYSUITS; BABY BOTTOMS; BABY DOLL PYJAMAS; BABY LAYETTES FOR CLOTHING; BALACLAVAS; BALLET SHOES; BALLET SLIPPERS; BANDANAS; BANDEAU TOPS; BASEBALL CAPS; BASEBALL CAPS AND HATS; BASEBALL UNIFORMS; BASKETBALL SNEAKERS; BATHING SUITS; BATHING SUITS FOR MEN; BATHING TRUNKS; BATHROBES; BEACH COVER-UPS; BEACH COVERUPS; BEACH FOOTWEAR; BEANIES; BED JACKETS; BELTS; BELTS MADE OF LEATHER; BELTS THAT ARE DESIGNED TO ACCOMMODATE PREGNANCY SIZE CHANGES; BERMUDA SHORTS; BICYCLE GLOVES; BIKINIS; BLAZERS; BLOUSES; BOARD SHORTS; BOAT SHOES; BODICES; BODY SHIRTS; BODY STOCKINGS; BODY SUITS; BOMBER JACKETS; BONNETS; BOOT ACCESSORIES, NAMELY, FITTED DECORATIVE COVERS FOR BOOTS; BOOTIES; BOTTOMS; BOW TIES; BOWLING SHOES; BOXER BRIEFS; BOXER SHORTS; BRACES; BRIEFS; BUCKET CAPS; BUSTIERS; BUTTON DOWN SHIRTS; CAMISETTES; CAMOUFLAGE GLOVES; CAMOUFLAGE JACKETS; CAMOUFLAGE PANTS; CAMOUFLAGE VESTS; CAP VISORS; CARDIGANS; CARGO PANTS; COATS; COLLARED SHIRTS; COLLARS; COVERALLS; CREW NECK SWEATERS; CREW NECKS; DECK-SHOES; DENIM JACKETS; DENIMS; DOWN JACKETS; DOWN SUITS; DRESS PANTS; DRESS SHIELDS; DRESS SHIRTS; DRESS SUITS; DRESSES; FABRIC BELTS; FLEECE BOTTOMS; FLEECE PULLOVERS; FLEECE SHORTS; FLEECE VESTS; FLIGHT SUITS; FLIP FLOPS; FOOTWEAR; FUR COATS; FUR COATS AND JACKETS; FUR HATS; FUR JACKETS; G-STRINGS; GLOVES; GOLF SHIRTS; GYM BOOTS; GYM PANTS; GYM SHORTS; HATS; HEAD SWEATBANDS; HEADBANDS; HEADWEAR; HEAVY JACKETS; HOODS; JACKET LINERS; JEANS; JERSEYS; JUMPSUITS; KNIT DRESSES; KNIT JACKETS; KNIT SKIRTS; LADIES' SUITS; LADIES' UNDERWEAR; LEATHER BELTS; LEATHER BOOTS; LEATHER COATS; LEATHER HATS; LEATHER HEADWEAR; LEATHER JACKETS; LEATHER PANTS; LEATHER SHIRTS; LEATHER SHOES; LEATHER SKIRTS; LEATHER SLIPPERS; LEATHER VESTS; LEG WARMERS; LEGGINGS; LEISURE SHOES; LINGERIE; LONG JACKETS; LONG SLEEVE PULLOVERS; LONG SLEEVED VESTS; MEN'S SOCKS; NECKWEAR; NIPPLE

CLASS 25—(Continued).

COVERS, NAMELY, PASTIES; OUTDOOR GLOVES; PAJAMAS; PANTIES; PANTS; PANTSUITS; PANTY-HOSE; RUNNING SUITS; SANDALS; SANDALS AND BEACH SHOES; SCARVES; SHIRTS; SHOES; SHORTS; SKI BOOTS; SKI GLOVES; SKI JACKETS; SKI MASKS; SKI PANTS; SKI SUITS; SKIRT SUITS; SKIRTS; SKIRTS AND DRESSES; SKULL CAPS; SLIDING SHORTS; SNEAKERS; SNOW BOARDING SUITS; SNOW BOOTS; SNOW PANTS; SNOW SUITS; SNOWBOARD BOOTS; SNOWBOARD GLOVES; SNOWBOARD JACKETS; SNOWBOARD MITTENS; SNOWBOARD PANTS; SOCCER SHOES; SOCKS; SPORT SHIRTS; SPORTS JACKETS; SPORTS JERSEYS; SPORTS PANTS; SPORTS SHIRTS; SWEAT JACKETS; SWEATSUITS; T-SHIRTS; TANK TOPS; TEE SHIRTS; TRACK JACKETS; TRACK PANTS; TRACKSUITS; TROUSERS; UNDERWEAR; V-NECK SWEATERS; VESTS; VISORS; WATERPROOF FOOTWEAR; WATERPROOF JACKETS AND PANTS; WET SUITS; WINDJAMMERS; WINDSHIRTS; WOMEN'S SHOES; ALL ITEMS MADE IN SUBSTANTIAL PART OF BAMBOO (U.S. CLS. 22 AND 39).

FIRST USE 2-2-2010; IN COMMERCE 5-18-2011.
TARAH HARDY, EXAMINING ATTORNEY

CLASS 25—(Continued).

SN 85-460,003. JOCKEY INTERNATIONAL, INC., KENOSHA, WI. FILED 10-31-2011.



OWNER OF U.S. REG. NO. 768,840.
THE MARK CONSISTS OF SILHOUETTE OF A STANDING JOCKEY.

FOR UNDERWEAR TOPS AND BOTTOMS; PANTIES; CAMISOLES; TANKS; BRAS; SOCKS; HOSIERY; LONG UNDERWEAR; ACTIVEWEAR, NAMELY, TOPS AND BOTTOMS, BRAS, TANKS, T-SHIRTS, PANTS, SHORTS AND JACKETS; SPORTSWEAR, NAMELY, TOPS AND BOTTOMS, BRAS, TANKS, T-SHIRTS, PANTS, SHORTS AND JACKETS; SLEEPWEAR; SHAPEWEAR, NAMELY, TOPS AND BOTTOMS, TANKS, CAMISOLES, SLIPS AND BODYSUITS; AND THERMAL UNDERWEAR TOPS AND BOTTOMS (U.S. CLS. 22 AND 39).
WILLIAM ROSSMAN, EXAMINING ATTORNEY

SN 85-459,708. SMUGGLER'S EVENT MANAGEMENT, LLC, PUNTA GORDA, FL. FILED 10-29-2011.



SN 85-460,648. RANGER BOATS, LLC, FLIPPIN, AR. FILED 10-31-2011.

RANGER BOATS

NO CLAIM IS MADE TO THE EXCLUSIVE RIGHT TO USE "SERIES", APART FROM THE MARK AS SHOWN.

THE MARK CONSISTS OF THE STYLIZED WORDING "FLATSMASTERS SERIES" AND A STYLIZED FISH.

FOR CLOTHING, NAMELY, TEE SHIRTS, POLO SHIRTS, BUTTON DOWN SHIRTS, SHORTS, AND HEADGEAR, NAMELY, HATS, VISORS, CAPS, BANDANAS (U.S. CLS. 22 AND 39).

FIRST USE 3-1-2001; IN COMMERCE 3-1-2001.
ERIN FALK, EXAMINING ATTORNEY

THE MARK CONSISTS OF STANDARD CHARACTERS WITHOUT CLAIM TO ANY PARTICULAR FONT, STYLE, SIZE, OR COLOR.

OWNER OF U.S. REG. NOS. 902,091 AND 1,135,100.
FOR CLOTHING, NAMELY, T-SHIRTS, HATS, VISORS, RAIN WEAR, JACKETS, POLO SHIRTS, SHIRTS, SWEATSHIRTS, AND SWEATPANTS (U.S. CLS. 22 AND 39).

PATRICIA EVANKO, EXAMINING ATTORNEY

CLASS 25—(Continued).

SN 85-460,868. BYER CALIFORNIA, SAN FRANCISCO, CA. FILED 10-31-2011.



THE MARK CONSISTS OF A FILLED-IN HEART DESIGN FOLLOWED BY AN AMPERSAND AND THE LOWER-CASE LETTERS "AMOR", WITH THE LETTER "O" BEING COMPLETELY FILLED IN.

THE ENGLISH TRANSLATION OF THE WORD "AMOR" IN THE MARK IS "LOVE".

FOR CLOTHING, NAMELY, DRESSES, SKIRTS, BLOUSES, SKORTS, SHORTS, SHIRTS, PANTS, JACKETS, SWEATERS, VESTS AND JUMPSUITS (U.S. CLS. 22 AND 39).

KATHLEEN KOLACZ, EXAMINING ATTORNEY

CLASS 25—(Continued).

SN 85-464,160. TURNER ENTERTAINMENT CO., BURBANK, CA. FILED 11-3-2011.

GLINDA THE GOOD WITCH

THE MARK CONSISTS OF STANDARD CHARACTERS WITHOUT CLAIM TO ANY PARTICULAR FONT, STYLE, SIZE, OR COLOR.

OWNER OF U.S. REG. NOS. 2,173,291 AND 2,462,292.

FOR CLOTHING FOR MEN, WOMEN AND CHILDREN, NAMELY, SHIRTS, T-SHIRTS, SWEATSHIRTS, JOGGING SUITS, TROUSERS, PANTS, SHORTS, TANK TOPS, RAINWEAR, CLOTH BABY BIBS, SKIRTS, BLOUSES, DRESSES, SUSPENDERS, SWEATERS, JACKETS, COATS, RAINCOATS, SNOW SUITS, TIES, ROBES, HATS, CAPS, SUN VISORS, BELTS, SCARVES, SLEEPWEAR, PAJAMAS, LINGERIE, UNDERWEAR, BOOTS, SHOES, SNEAKERS, SANDALS, SOCKS, BOOTIES, SLIPPER SOCKS, SWIMWEAR AND MASQUERADE AND HALLOWEEN COSTUMES AND MASKS SOLD IN CONNECTION THEREWITH (U.S. CLS. 22 AND 39).

FIRST USE 1-15-2012; IN COMMERCE 1-15-2012.

GINA FINK, EXAMINING ATTORNEY

SN 85-464,313. RAY WILLIAM JOHNSON, MARINA DEL REY, CA. AND MAKER STUDIOS, INC., MARINA DEL REY, CA. FILED 11-4-2011.

SN 85-462,132. SUPERBEACH TEES, INC., CLEARWATER, FL. FILED 11-2-2011.



NO CLAIM IS MADE TO THE EXCLUSIVE RIGHT TO USE "SUPER BEACH TEES", APART FROM THE MARK AS SHOWN.

THE STIPPLING IS FOR SHADING PURPOSES ONLY.

THE MARK CONSISTS OF THE STYLIZED TEXT "SUPER BEACH" ARCHING ABOVE THE STYLIZED TEXT "TEES" IN WHICH THE LETTER "T" IS REPRESENTED BY A PALM TREE.

FOR BEACH COVER-UPS; HATS; T-SHIRTS; VISORS (U.S. CLS. 22 AND 39).

WON TEAK OH, EXAMINING ATTORNEY

YOUR FAVORITE MARTIAN

THE MARK CONSISTS OF STANDARD CHARACTERS WITHOUT CLAIM TO ANY PARTICULAR FONT, STYLE, SIZE, OR COLOR.

FOR CLOTHING, NAMELY, T-SHIRTS, HATS, SWEATSHIRTS, AND SHOES (U.S. CLS. 22 AND 39).

KIM MONINGHOFF, EXAMINING ATTORNEY

SN 85-466,336. WORLD WRESTLING ENTERTAINMENT, INC., STAMFORD, CT. FILED 11-7-2011.

WWE HOUSE OF FAME

THE MARK CONSISTS OF STANDARD CHARACTERS WITHOUT CLAIM TO ANY PARTICULAR FONT, STYLE, SIZE, OR COLOR.

OWNER OF U.S. REG. NOS. 3,538,710, 4,042,468 AND 4,045,760.

FOR CLOTHING, NAMELY, TOPS, JACKETS, BOTTOMS, UNDERWEAR, PAJAMAS; FOOTWEAR, NAMELY, SHOES, SNEAKERS, SLIPPERS; HEADWEAR, NAMELY, HATS (U.S. CLS. 22 AND 39).

ALEX KEAM, EXAMINING ATTORNEY

CLASS 25—(Continued).

SN 85-468,954. SEITZ, NICHOLAS P., SYRACUSE, NY.
FILED 11-9-2011.

Who Yinz?

THE MARK CONSISTS OF STANDARD CHARACTERS
WITHOUT CLAIM TO ANY PARTICULAR FONT, STYLE,
SIZE, OR COLOR.
FOR SHORT-SLEEVED OR LONG-SLEEVED T-SHIRTS
(U.S. CLS. 22 AND 39).
FIRST USE 11-8-2011; IN COMMERCE 11-8-2011.
SANI KHOURI, EXAMINING ATTORNEY

SN 85-471,223. THAT WAS THEN ENTERPRISES, LOS
ANGELES, CA. FILED 11-13-2011.

FEEL MORE BETTER

THE MARK CONSISTS OF STANDARD CHARACTERS
WITHOUT CLAIM TO ANY PARTICULAR FONT, STYLE,
SIZE, OR COLOR.
FOR CLOTHING, NAMELY, BLOUSES, HALTER
TOPS, TANK TOPS, CROP TOPS, CARDIGANS, JER-
SEYS, T-SHIRTS, TOPS, SHIRTS, KNIT SHIRTS, POLO
SHIRTS, SWEATERS, PULLOVERS, TURTLENECKS,
VESTS, SWEATSHIRTS, SWEATPANTS, UNDERWEAR,
SLEEPWEAR, PAJAMAS, SWIMWEAR, BEACHWEAR,
COVER-UPS, LINGERIE, BRAS, PANTIES, AND HEAD-
WEAR (U.S. CLS. 22 AND 39).
WENDY JUN, EXAMINING ATTORNEY

SN 85-471,719. INDUSTRIAS Y CONFECCIONES, S.A. -
INDUYCO, 28045 MADRID, SPAIN, FILED 11-14-2011.

TINTORETTO

THE MARK CONSISTS OF STANDARD CHARACTERS
WITHOUT CLAIM TO ANY PARTICULAR FONT, STYLE,
SIZE, OR COLOR.
FOR DRESSES, FOOTWEAR, AND HATS (U.S. CLS. 22
AND 39).
BRIAN PINO, EXAMINING ATTORNEY

CLASS 25—(Continued).

SN 85-474,521. SOURCE INTERLINK MAGAZINES, LLC, EL
SEGUNDO, CA. FILED 11-16-2011.

MUD LIFE

THE MARK CONSISTS OF STANDARD CHARACTERS
WITHOUT CLAIM TO ANY PARTICULAR FONT, STYLE,
SIZE, OR COLOR.
OWNER OF U.S. REG. NO. 3,748,352.
FOR BELTS; BLOUSES; DRESSES; JACKETS; PANTS;
SHIRTS; SKIRTS; SOCKS (U.S. CLS. 22 AND 39).
FONG HSU, EXAMINING ATTORNEY

SN 85-481,848. GLOBAL TRADEMARKS, INC., STOCKER-
TOWN, PA. FILED 11-28-2011.

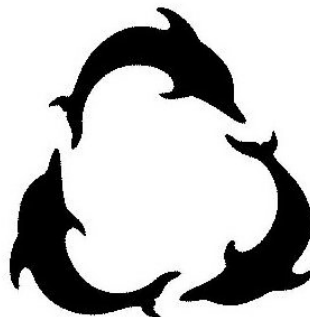

THE MARK CONSISTS OF AN IMAGE OF THREE
DOLPHINS SWIMMING NOSE TO TAIL IN A CIRCLE.
FOR SWIMWEAR (U.S. CLS. 22 AND 39).
CHRISTINA SOBRAL, EXAMINING ATTORNEY

SN 85-482,050. 2253 APPAREL INC., DBA CELEBRITY PINK
INC., MONTEBELLO, CA. FILED 11-28-2011.

CELEBRITY BLUES

THE MARK CONSISTS OF STANDARD CHARACTERS
WITHOUT CLAIM TO ANY PARTICULAR FONT, STYLE,
SIZE, OR COLOR.
NO CLAIM IS MADE TO THE EXCLUSIVE RIGHT TO
USE "BLUES", APART FROM THE MARK AS SHOWN.
FOR DENIMS, PANTS, TOPS, JACKETS, SHIRTS,
SKIRTS, T-SHIRTS, DRESSES, HATS, CAPS, JEANS,
BLOUSES, OVERALLS, SHOES, UNDERGARMENTS,
SHORTS (U.S. CLS. 22 AND 39).
KATHLEEN LORENZO, EXAMINING ATTORNEY

CLASS 25—(Continued).

SN 85-482,436. GLOBAL TRADEMARKS, INC., STOCKERTOWN, PA. FILED 11-29-2011.

SlimSolutions

THE MARK CONSISTS OF STANDARD CHARACTERS WITHOUT CLAIM TO ANY PARTICULAR FONT, STYLE, SIZE, OR COLOR.

FOR JEANS; SHAPEWEAR, NAMELY, BRAS, PANTIES, GIRDLES, AND CAMISOLES; SWIMWEAR (U.S. CLS. 22 AND 39).

CHRISTINA SOBRAL, EXAMINING ATTORNEY

CLASS 25—(Continued).

SN 85-483,392. COLUMBIA INSURANCE COMPANY, OMAHA, NE. FILED 11-30-2011.

LIVSKO

THE MARK CONSISTS OF STANDARD CHARACTERS WITHOUT CLAIM TO ANY PARTICULAR FONT, STYLE, SIZE, OR COLOR.

FOR FOOTWEAR (U.S. CLS. 22 AND 39).
FIRST USE 1-1-2009; IN COMMERCE 1-1-2009.
BERYL GARDNER, EXAMINING ATTORNEY

SN 85-483,372. COLUMBIA INSURANCE COMPANY, OMAHA, NE. FILED 11-30-2011.

SOFSKO

THE MARK CONSISTS OF STANDARD CHARACTERS WITHOUT CLAIM TO ANY PARTICULAR FONT, STYLE, SIZE, OR COLOR.

FOR FOOTWEAR (U.S. CLS. 22 AND 39).
FIRST USE 1-1-2009; IN COMMERCE 1-1-2009.
BERYL GARDNER, EXAMINING ATTORNEY

SN 85-483,383. COLUMBIA INSURANCE COMPANY, OMAHA, NE. FILED 11-30-2011.

DROFT

THE MARK CONSISTS OF STANDARD CHARACTERS WITHOUT CLAIM TO ANY PARTICULAR FONT, STYLE, SIZE, OR COLOR.

FOR FOOTWEAR (U.S. CLS. 22 AND 39).
FIRST USE 1-1-2009; IN COMMERCE 1-1-2009.
BERYL GARDNER, EXAMINING ATTORNEY

SN 85-484,511. REBECCA WALL, LAWRENCEBURG, KY. FILED 12-1-2011.



THE MARK CONSISTS OF THE LITERAL CHARACTERS "NESCOT" WHEREIN THE ELEMENTS MAKING UP THE "T" CHARACTER ARE CROSSED AND A SHIELD-SHAPED ITEM OF NECKWEAR IS DISPOSED BELOW THE "O" CHARACTER.

FOR NECKWEAR (U.S. CLS. 22 AND 39).
FIRST USE 1-12-2012; IN COMMERCE 1-12-2012.
LAURIE KAUFMAN, EXAMINING ATTORNEY

SN 85-489,216. BRANDSOURCE, INC., NEW YORK, NY. FILED 12-7-2011.

Seksi

THE MARK CONSISTS OF STANDARD CHARACTERS WITHOUT CLAIM TO ANY PARTICULAR FONT, STYLE, SIZE, OR COLOR.

FOR BOTTOMS; BRAS; FOOTWEAR FOR MEN AND WOMEN; JEANS; LINGERIE; MEN'S AND WOMEN'S JACKETS, COATS, TROUSERS, VESTS; PAJAMAS; PANTIES; SWIMSUITS; UNDERWEAR; WOMEN'S CLOTHING, NAMELY, SHIRTS, DRESSES, SKIRTS, BLOUSES (U.S. CLS. 22 AND 39).

ERNEST SHOSHO, EXAMINING ATTORNEY

CLASS 25—(Continued).

SN 85-490,639. SAUCONY, INC., LEXINGTON, MA. FILED 12-8-2011.



OWNER OF U.S. REG. NOS. 3,030,404, 3,824,276 AND OTHERS.

THE MARK CONSISTS OF THE NUMBERS "26.2012" AND UNDERNEATH THE NUMBER "2012" TO THE RIGHT-SIDE IS THE WORDING IN LOWER CASE FONT "SAUCONY" WITH A DESIGN ELEMENT FEATURING AN ELONGATED S-SHAPE WITH AN EXTENDING BOTTOM TAIL, THREE CIRCLES ON THE MIDSECTION, AND A SHORT TOP PORTION.

FOR SHORT-SLEEVED OR LONG-SLEEVED T-SHIRTS (U.S. CLS. 22 AND 39).

Laurie Kaufman, Examining Attorney

SN 85-490,767. SAUCONY, INC., LEXINGTON, MA. FILED 12-8-2011.



OWNER OF U.S. REG. NOS. 3,030,404, 3,824,276 AND OTHERS.

THE MARK CONSISTS OF THE NUMBERS "26.2013" AND UNDERNEATH THE NUMBER "2013" TO THE RIGHT-SIDE IS THE WORDING IN LOWER CASE FONT "SAUCONY" WITH A DESIGN ELEMENT FEATURING AN ELONGATED S-SHAPE WITH AN EXTENDING BOTTOM TAIL, THREE CIRCLES ON THE MIDSECTION, AND A SHORT TOP PORTION.

FOR SHORT-SLEEVED OR LONG-SLEEVED T-SHIRTS (U.S. CLS. 22 AND 39).

Laurie Kaufman, Examining Attorney

SN 85-490,986. GLOBAL TRADEMARKS, INC., STOCKERTOWN, PA. FILED 12-8-2011.

ECO BREEZE

THE MARK CONSISTS OF STANDARD CHARACTERS WITHOUT CLAIM TO ANY PARTICULAR FONT, STYLE, SIZE, OR COLOR.

FOR BEACH COVER-UPS; SWIMWEAR (U.S. CLS. 22 AND 39).

Christina Sobral, Examining Attorney

CLASS 25—(Continued).

SN 85-490,989. GLOBAL TRADEMARKS, INC., STOCKERTOWN, PA. FILED 12-8-2011.

ECO TROPICAL

THE MARK CONSISTS OF STANDARD CHARACTERS WITHOUT CLAIM TO ANY PARTICULAR FONT, STYLE, SIZE, OR COLOR.

FOR BEACH COVER-UPS; SWIMWEAR (U.S. CLS. 22 AND 39).

Christina Sobral, Examining Attorney

SN 85-490,990. GLOBAL TRADEMARKS, INC., STOCKERTOWN, PA. FILED 12-8-2011.

ECO FOREVER

THE MARK CONSISTS OF STANDARD CHARACTERS WITHOUT CLAIM TO ANY PARTICULAR FONT, STYLE, SIZE, OR COLOR.

FOR BEACH COVER-UPS; SWIMWEAR (U.S. CLS. 22 AND 39).

Christina Sobral, Examining Attorney

SN 85-491,243. SAUCONY, INC., LEXINGTON, MA. FILED 12-9-2011.



OWNER OF U.S. REG. NOS. 3,030,404, 3,824,276 AND OTHERS.

THE MARK CONSISTS OF THE NUMBERS "26.2014" AND UNDERNEATH THE NUMBER "2014" TO THE RIGHT-SIDE IS THE WORDING IN LOWER CASE FONT "SAUCONY" WITH A DESIGN ELEMENT FEATURING AN ELONGATED S-SHAPE WITH AN EXTENDING BOTTOM TAIL, THREE CIRCLES ON THE MIDSECTION, AND A SHORT TOP PORTION.

FOR SHORT-SLEEVED OR LONG-SLEEVED T-SHIRTS (U.S. CLS. 22 AND 39).

Laurie Kaufman, Examining Attorney

CLASS 25—(Continued).

SN 85-493,121. NINE WEST DEVELOPMENT CORPORATION, WILMINGTON, DE. FILED 12-12-2011.



THE MARK CONSISTS OF THE WORD "LOVE" IN LOWER CASE CURSIVE OVER THE WORD "FURY" IN LOWER CASE CURSIVE.
FOR BELTS; BOTTOMS; FOOTWEAR; GLOVES; HATS; SCARVES; TOPS (U.S. CLS. 22 AND 39).
GRETTA YAO, EXAMINING ATTORNEY

SN 85-494,428. NASCA LLC, MOUNT PLEASANT, SC. FILED 12-13-2011.

**National Association of
Southern Confederate
Americans**

THE MARK CONSISTS OF STANDARD CHARACTERS WITHOUT CLAIM TO ANY PARTICULAR FONT, STYLE, SIZE, OR COLOR.
FOR ATHLETIC APPAREL, NAMELY, SHIRTS, PANTS, JACKETS, FOOTWEAR, HATS AND CAPS, ATHLETIC UNIFORMS; BANDANAS; BASEBALL CAPS; BASEBALL CAPS AND HATS; BEACH FOOTWEAR; BELTS; BELTS FOR CLOTHING; BELTS MADE FROM IMITATION LEATHER; CAMOUFLAGE GLOVES; CAMOUFLAGE JACKETS; CAMOUFLAGE PANTS; CAMOUFLAGE SHIRTS; CAMOUFLAGE VESTS; CAP VISORS; GIFT PACKAGES SOLD AS A UNIT CONSISTING PRIMARILY OF A SWEATSHIRT AND ALSO INCLUDING A PHOTO FRAME, A COFFEE MUG, AND A TOTE BAG; HOODED SWEAT SHIRTS; LEATHER BELTS; LEATHER VESTS; T-SHIRTS; TANK TOPS; TIES; WEARABLE GARMENTS AND CLOTHING, NAMELY, SHIRTS (U.S. CLS. 22 AND 39).
CHRISTOPHER BUONGIORNO, EXAMINING ATTORNEY

CLASS 25—(Continued).

SN 85-499,281. BYER CALIFORNIA, SAN FRANCISCO, CA. FILED 12-19-2011.

B.WEAR BYER GIRL

THE MARK CONSISTS OF STANDARD CHARACTERS WITHOUT CLAIM TO ANY PARTICULAR FONT, STYLE, SIZE, OR COLOR.
OWNER OF U.S. REG. NOS. 2,897,348, 3,041,677 AND 3,294,904.
NO CLAIM IS MADE TO THE EXCLUSIVE RIGHT TO USE "GIRL", APART FROM THE MARK AS SHOWN.
FOR CLOTHING, NAMELY, DRESSES, SKIRTS, BLOUSES, SHORTS, SHIRTS, PANTS, JACKETS, AND SWEATERS (U.S. CLS. 22 AND 39).
FIRST USE 8-11-2009; IN COMMERCE 8-11-2009.
KATHLEEN KOLACZ, EXAMINING ATTORNEY

SN 85-520,247. HYRO-GLIFF, NEW YORK, NY. FILED 1-19-2012.

EVERYONE PARTIES IN CABO

THE MARK CONSISTS OF STANDARD CHARACTERS WITHOUT CLAIM TO ANY PARTICULAR FONT, STYLE, SIZE, OR COLOR.
FOR CLOTHING, NAMELY, SHIRTS, T-SHIRTS, UNDER SHIRTS, NIGHT SHIRTS, RUGBY SHIRTS, POLO SHIRTS, CARDIGANS, JERSEYS, SCRUBS NOT FOR MEDICAL PURPOSES, SMOCKS, PANTS, JEANS, CULOTTES, CARGO PANTS, STRETCH PANTS, DENIM JEANS, OVERALLS, SHORTS, BOXER SHORTS, TOPS, STRETCH TOPS, CROP TOPS, TANK TOPS, TANKINIS, SWEAT SHIRTS, HOODED SWEAT SHIRTS, SWEAT SHORTS, SWEAT PANTS, WRAPS, WARM-UP SUITS, JOGGING SUITS, SKIRTS, DRESSES, SWEATERS, VESTS, FLEECE VESTS, PULLOVERS, SNOW SUITS, PARKAS, CAPES, ANORAKS, PONCHOS, JACKETS, REVERSIBLE JACKETS, WIND-RESISTANT JACKETS, SHELL JACKETS, SPORTS JACKETS, JEAN JACKETS, COATS, SUITS, TURTLENECKS, SWIMWEAR, BEACHWEAR, LAYETTES, INFANTWEAR, INFANTS SLEEPERS, BOOTIES, BABY BIBS NOT OF PAPER, CAPS, HATS, VISORS, HEADBANDS, WRIST BANDS, SWEAT BANDS, HEADWEAR, EAR MUFFS, APRONS, SCARVES, BANDANAS, BELTS, SUSPENDERS, NECKWEAR, UNDERWEAR, THONGS, SINGLETS, SOCKS, LOUNGEWEAR, ROBES, UNDERCLOTHES, PAJAMAS, SLEEPWEAR, LEG WARMERS, HOSIERY, LEGGINGS, TIGHTS, GLOVES, MITTENS, RAIN SLICKERS, RAINWEAR, FOOTWEAR, SHOES, SNEAKERS, GALOSHES, SANDALS, FLIP-FLOPS, AND SLIPPERS (U.S. CLS. 22 AND 39).
ANDREA K. NADELMAN, EXAMINING ATTORNEY

CLASS 25—(Continued).

SN 85-525,930. MORRIS, MAURICE A., BELLEVILLE, MI. FILED 1-26-2012.



THE MARK CONSISTS OF THREE INTERTWINED "L"'S WITHIN AN OVAL ABOVE THE STYLIZED WORDING "LAVISH" ABOVE THE STYLIZED WORDING "LUXURY LANDWEAR".

FOR PANTS, SHIRTS, SHORTS, JACKETS, SUITS, SHOES (U.S. CLS. 22 AND 39).

FIRST USE 9-1-1998; IN COMMERCE 8-9-1999.
KAREN K. BUSH, EXAMINING ATTORNEY

CLASS 26—FANCY GOODS

SN 85-300,671. GOGREEN ENTERPRISES LLC, BOULDER, CO. FILED 4-21-2011.

ADAPT-A-SNAP

THE MARK CONSISTS OF STANDARD CHARACTERS WITHOUT CLAIM TO ANY PARTICULAR FONT, STYLE, SIZE, OR COLOR.

FOR CLOTHING HOOKS AND LOOPS FOR CLOTH DIAPERS; CLOTHING HOOKS AND LOOP SNAP FASTENERS USED FOR CLOTH DIAPERS; HOOK AND LOOP FASTENING TAPE USED FOR CLOTH DIAPERS (U.S. CLS. 37, 39, 40, 42 AND 50).

SAMUEL E. SHARPER JR., EXAMINING ATTORNEY

CLASS 26—(Continued).

SN 85-350,818. SMITH INTERNATIONAL ENTERPRISES, INC., SHAKER HEIGHTS, OH. FILED 6-20-2011.

NO CLAIM IS MADE TO THE EXCLUSIVE RIGHT TO USE "BLOCK & ROLL", APART FROM THE MARK AS SHOWN.

THE MARK CONSISTS OF THE WORDS "BLOCK ROLL" WITH AN AMPERSAND DESIGN BETWEEN THE WORDS. FOR BLOCKING MAT (U.S. CLS. 37, 39, 40, 42 AND 50).

FIRST USE 5-1-2011; IN COMMERCE 6-12-2011.
ALICE BENMAMAN, EXAMINING ATTORNEY

SN 85-425,825. NWOKOLO, OBIOMA, FOREST HILLS, NY. FILED 9-19-2011.

Klipease

THE MARK CONSISTS OF STANDARD CHARACTERS WITHOUT CLAIM TO ANY PARTICULAR FONT, STYLE, SIZE, OR COLOR.

FOR HAIR CLIPS (U.S. CLS. 37, 39, 40, 42 AND 50).

FIRST USE 3-1-2011; IN COMMERCE 9-16-2011.
DAVID C. REIHNER, EXAMINING ATTORNEY

SN 85-439,702. J&K HAIR GALLERY, INC., ROWLAND HEIGHTS, CA. FILED 10-5-2011.

NO CLAIM IS MADE TO THE EXCLUSIVE RIGHT TO USE "HAIR", APART FROM THE MARK AS SHOWN.

THE MARK CONSISTS OF SIX WAVY LINES FOLLOWED BY THE WORDS "J&K HAIR GALLERY".

FOR WIGS, HAIRPIECES, AND ADD-IN AND ADD-ON HAIR ACCESSORIES CONSTRUCTED PRIMARILY OF SYNTHETIC AND/OR HUMAN HAIR (U.S. CLS. 37, 39, 40, 42 AND 50).

AMY KELLY, EXAMINING ATTORNEY

CLASS 26—(Continued).

SN 85-439,714. J&K HAIR GALLERY, INC., ROWLAND HEIGHTS, CA. FILED 10-5-2011.

SANDRA SIMPSON

THE MARK CONSISTS OF STANDARD CHARACTERS WITHOUT CLAIM TO ANY PARTICULAR FONT, STYLE, SIZE, OR COLOR.

THE NAME "SANDRA SIMPSON" DOES NOT IDENTIFY A LIVING INDIVIDUAL.

FOR WIGS, HAIRPIECES, AND ADD-IN AND ADD-ON HAIR ACCESSORIES CONSTRUCTED PRIMARILY OF SYNTHETIC AND/OR HUMAN HAIR (U.S. CLS. 37, 39, 40, 42 AND 50).

AMY KELLY, EXAMINING ATTORNEY

CLASS 26—(Continued).

SN 85-474,654. THANE INTERNATIONAL, INC., LA QUINTA, CA. FILED 11-16-2011.

TOUCH OF GLAM

THE MARK CONSISTS OF STANDARD CHARACTERS WITHOUT CLAIM TO ANY PARTICULAR FONT, STYLE, SIZE, OR COLOR.

FOR HAIR ACCESSORIES, NAMELY, FEATHER HAIR EXTENSIONS; HAIR EXTENSIONS; HAIR PIECES AND WIGS (U.S. CLS. 37, 39, 40, 42 AND 50).

JILL PRATER, EXAMINING ATTORNEY

SN 85-447,395. JILL BOEHLER, MARLTON, NJ. FILED 10-14-2011.

DUELETTE

THE MARK CONSISTS OF STANDARD CHARACTERS WITHOUT CLAIM TO ANY PARTICULAR FONT, STYLE, SIZE, OR COLOR.

FOR HAIR TIE THAT CAN ALSO BE WORN AS A BRACELET (U.S. CLS. 37, 39, 40, 42 AND 50).

SHANNON TWOHIG, EXAMINING ATTORNEY

CLASS 27—FLOOR COVERINGS

SN 85-449,918. LET'S GEL, INC., AUSTIN, TX. FILED 10-18-2011.

Ergo Comfort Rug

THE MARK CONSISTS OF STANDARD CHARACTERS WITHOUT CLAIM TO ANY PARTICULAR FONT, STYLE, SIZE, OR COLOR.

NO CLAIM IS MADE TO THE EXCLUSIVE RIGHT TO USE "COMFORT RUG", APART FROM THE MARK AS SHOWN.

FOR ANTI-FATIGUE FLOOR MAT (U.S. CLS. 19, 20, 37, 42 AND 50).

LAURA KOVALSKY, EXAMINING ATTORNEY

SN 85-450,229. ATLASGUARD LLC, SAN DIEGO, CA. FILED 10-18-2011.

iRACK

THE MARK CONSISTS OF STANDARD CHARACTERS WITHOUT CLAIM TO ANY PARTICULAR FONT, STYLE, SIZE, OR COLOR.

FOR FASTENERS FOR ATTACHING MILITARY MEDALS TO CLOTHING (U.S. CLS. 37, 39, 40, 42 AND 50). FIRST USE 8-27-2011; IN COMMERCE 8-27-2011.

DOUGLAS LEE, EXAMINING ATTORNEY

SN 85-474,408. COLUMBIA INSURANCE COMPANY, OMAHA, NE. FILED 11-16-2011.

VISCOTOUCH

THE MARK CONSISTS OF STANDARD CHARACTERS WITHOUT CLAIM TO ANY PARTICULAR FONT, STYLE, SIZE, OR COLOR.

FOR CARPET PADDING (U.S. CLS. 19, 20, 37, 42 AND 50).

BERYL GARDNER, EXAMINING ATTORNEY

CLASS 27—(Continued).

SN 85-513,994. LET'S GEL, INC., AUSTIN, TX. FILED 1-11-2012.

NEWLIFE

THE MARK CONSISTS OF STANDARD CHARACTERS WITHOUT CLAIM TO ANY PARTICULAR FONT, STYLE, SIZE, OR COLOR.

FOR CARPETS, RUGS, MATS, NAMELY, RESILIENT CARPETS, RUGS, AND FLOOR MATS (U.S. CLS. 19, 20, 37, 42 AND 50).

LAURA KOVALSKY, EXAMINING ATTORNEY

CLASS 28—(Continued).

SN 76-709,623. JAY AT PLAY INTERNATIONAL HONG KONG LIMITED, HONG KONG, CHINA, FILED 11-2-2011.

SKOOL CAN BE KOOL

THE MARK CONSISTS OF STANDARD CHARACTERS WITHOUT CLAIM TO ANY PARTICULAR FONT, STYLE, SIZE, OR COLOR.

FOR PLUSH STUFFED ANIMALS AND PLUSH TOYS (U.S. CLS. 22, 23, 38 AND 50).

MICHAEL GAAFAR, EXAMINING ATTORNEY

CLASS 28—TOYS AND SPORTING GOODS

SN 76-708,744. ELLIOTT, JOSEPH THOMAS, FONTANA, CA. FILED 8-15-2011.

NUM - ALPHA

THE MARK CONSISTS OF STANDARD CHARACTERS WITHOUT CLAIM TO ANY PARTICULAR FONT, STYLE, SIZE, OR COLOR.

FOR INTERLOCKING PIECES TO BUILD TOY STRUCTURES (U.S. CLS. 22, 23, 38 AND 50).

DANNEAN HETZEL, EXAMINING ATTORNEY

SN 76-709,777. JAY AT PLAY INTERNATIONAL HONG KONG LIMITED, HONG KONG, CHINA, FILED 11-18-2011.

CHEER UP CHARLIE

THE MARK CONSISTS OF STANDARD CHARACTERS WITHOUT CLAIM TO ANY PARTICULAR FONT, STYLE, SIZE, OR COLOR.

FOR PLUSH STUFFED ANIMALS AND PLUSH TOYS (U.S. CLS. 22, 23, 38 AND 50).

MICHAEL GAAFAR, EXAMINING ATTORNEY

SN 76-709,447. TOOT SWEET TOYS, INC., NEW YORK, NY. FILED 10-18-2011.

PILLOW PIRATES

THE MARK CONSISTS OF STANDARD CHARACTERS WITHOUT CLAIM TO ANY PARTICULAR FONT, STYLE, SIZE, OR COLOR.

NO CLAIM IS MADE TO THE EXCLUSIVE RIGHT TO USE "PILLOW", APART FROM THE MARK AS SHOWN.

FOR PLUSH DOLLS AND PLUSH TOYS (U.S. CLS. 22, 23, 38 AND 50).

CHRISIE B. KING, EXAMINING ATTORNEY

SN 76-709,989. JAY AT PLAY INTERNATIONAL HONG KONG LIMITED, HONG KONG, CHINA, FILED 12-14-2011.

HATCHKINS

THE MARK CONSISTS OF STANDARD CHARACTERS WITHOUT CLAIM TO ANY PARTICULAR FONT, STYLE, SIZE, OR COLOR.

FOR PLUSH STUFFED ANIMALS AND PLUSH TOYS (U.S. CLS. 22, 23, 38 AND 50).

MICHAEL GAAFAR, EXAMINING ATTORNEY

CLASS 28—(Continued).

SN 77-669,361. ROLL RELEASE INC., CALGARY, ALB., CANADA, FILED 2-12-2009.

CLASS 28—(Continued).

SN 85-258,238. PARADIGM LEARNING INC., ST PETERSBURG, FL. FILED 3-4-2011.

Release Roller



THE MARK CONSISTS OF STANDARD CHARACTERS WITHOUT CLAIM TO ANY PARTICULAR FONT, STYLE, SIZE, OR COLOR.

PRIORITY CLAIMED UNDER SEC. 44(D) ON CANADA APPLICATION NO. 1407095, FILED 8-13-2008, REG. NO. TMA806062, DATED 9-6-2011, EXPIRES 9-6-2026.

NO CLAIM IS MADE TO THE EXCLUSIVE RIGHT TO USE "ROLLER", APART FROM THE MARK AS SHOWN.

FOR EXERCISE EQUIPMENT, NAMELY, STRENGTH AND FLEXIBILITY TRAINING EQUIPMENT IN THE SHAPE OF A CYLINDER SURROUNDED BY FOAM (U.S. CLS. 22, 23, 38 AND 50).

ALAIN LAPTER, EXAMINING ATTORNEY

NO CLAIM IS MADE TO THE EXCLUSIVE RIGHT TO USE "Z", APART FROM THE MARK AS SHOWN.

THE MARK CONSISTS OF A CAPITAL LETTER "Z" IN RECTANGULAR BOX WITH VERTICAL MARKS AT TOP AND BOTTOM.

SEC. 2(F).

FOR BOARD GAMES (U.S. CLS. 22, 23, 38 AND 50).

FIRST USE 7-1-2010; IN COMMERCE 7-31-2010.

FLORENTINA BLANDU, EXAMINING ATTORNEY

SN 85-096,950. INNOVATION INDUSTRIES, MEDIA, PA. FILED 7-30-2010.

SN 85-279,498. THE BRAMTON COMPANY, IRVING, TX. FILED 3-29-2011.

The Plank

PEE POST

THE MARK CONSISTS OF STANDARD CHARACTERS WITHOUT CLAIM TO ANY PARTICULAR FONT, STYLE, SIZE, OR COLOR.

FOR MANUALLY OPERATED EXERCISE EQUIPMENT INCORPORATING RESISTANT EXERCISE BANDS FOR STRETCHING AND TONING (U.S. CLS. 22, 23, 38 AND 50).

HELENE LIWINSKI, EXAMINING ATTORNEY

THE MARK CONSISTS OF STANDARD CHARACTERS WITHOUT CLAIM TO ANY PARTICULAR FONT, STYLE, SIZE, OR COLOR.

OWNER OF U.S. REG. NO. 2,932,101.

SEC. 2(F).

FOR ANIMAL ATTRACTANT YARD STAKE (U.S. CLS. 22, 23, 38 AND 50).

FIRST USE 7-8-2003; IN COMMERCE 7-8-2003.

ALLISON SCHRODY, EXAMINING ATTORNEY

CLASS 28—(Continued).

SN 85-281,252. AGATSUMA CO., LTD., TOKYO, JAPAN,
FILED 3-30-2011.



THE MARK CONSISTS OF THE WORD "QMIX" WITHIN A BACKGROUND WITH THE OUTLINE IN THE SHAPE OF THE LETTERS WHICH IS WITHIN A RECTANGLE WITH ROUNDED CORNERS.

FOR CHILDREN'S PLAYTHINGS FOR RECREATIONAL PURPOSES, NAMELY, SWING SETS, ARTIFICIAL CLIMBING WALL; CHILDREN'S PLAYGROUND EQUIPMENT, NAMELY, CLIMBING UNITS, SLIDES, SWINGS, RIDE-ON TOYS AND TRAMPOLINES; RIDE-ON TOYS AND STRUCTURAL PARTS THEREFOR; SWINGS AND STRUCTURAL PARTS THEREFOR; TRAMPOLINES AND STRUCTURAL PARTS THEREFOR; CLIMBING UNITS AND STRUCTURAL PARTS THEREFOR; SLIDES AND STRUCTURAL PARTS; JUNGLE GYM; CHILDREN'S MULTIPLE ACTIVITY TOYS; MODULAR PLAY CENTERS CONSISTING OF PANELS, RAILS, SLIDES, SWINGS, STEPS, RIDE-ON TOYS, TRAMPOLINES, AND STRUCTURAL PARTS, SOLD IN SELECTED COMBINATION OR SEPARATELY (U.S. CLS. 22, 23, 38 AND 50).

CARYN GLASSER, EXAMINING ATTORNEY

SN 85-284,368. DAS DISTRIBUTORS, INC., PALMYRA, PA.
FILED 4-1-2011.



NO CLAIM IS MADE TO THE EXCLUSIVE RIGHT TO USE "LANCASTER COUNTY TACKLE CO.", APART FROM THE MARK AS SHOWN.

THE MARK CONSISTS OF THE WORDS "LANCASTER COUNTY TACKLE CO." WITH A WAVE AND A JUMPING FISH.

FOR FISHING LURES (U.S. CLS. 22, 23, 38 AND 50).
JOHN KELLY, EXAMINING ATTORNEY

CLASS 28—(Continued).

SN 85-292,216. MANSON WESTERN CORPORATION, DBA
WESTERN PSYCHOLOGICAL SERVICES, LOS ANGELES,
CA. FILED 4-11-2011.

Creative Therapy Store

THE MARK CONSISTS OF STANDARD CHARACTERS WITHOUT CLAIM TO ANY PARTICULAR FONT, STYLE, SIZE, OR COLOR.

NO CLAIM IS MADE TO THE EXCLUSIVE RIGHT TO USE "THERAPY STORE", APART FROM THE MARK AS SHOWN.

SEC. 2(F).

FOR THERAPEUTIC AND EDUCATIONAL GAMES, TOYS, AND INTERVENTION ACTIVITIES THAT MAY ASSIST IN THE DIAGNOSIS OR THERAPY OF CHILDREN OR ADULTS WITH POTENTIAL BEHAVIORAL OR MENTAL DISORDERS, NAMELY, BOARD GAMES, CARD GAMES, ART PROJECTS IN THE NATURE OF EDUCATIONAL GAMES FOR THE TEACHING OF CHILDREN THROUGH THE USE OF ART, MOLDED PLASTIC TOY FIGURINES, AND DOLLS (U.S. CLS. 22, 23, 38 AND 50).

FIRST USE 1-1-1991; IN COMMERCE 1-1-1991.

SEAN CROWLEY, EXAMINING ATTORNEY

SN 85-300,006. G.I. SPORTZ INC., LACHINE, QUEBEC,
CANADA, FILED 4-20-2011.

GOLD HELLFIRE

THE MARK CONSISTS OF STANDARD CHARACTERS WITHOUT CLAIM TO ANY PARTICULAR FONT, STYLE, SIZE, OR COLOR.

OWNER OF U.S. REG. NOS. 2,929,233, 3,057,849 AND 3,312,250.

FOR PAINTBALLS (U.S. CLS. 22, 23, 38 AND 50).

FIRST USE 2-9-2011; IN COMMERCE 2-9-2011.

MARK SPARACINO, EXAMINING ATTORNEY

SN 85-300,691. RALEIGH WILLIAM BAIRD, HOUSTON, TX.
FILED 4-21-2011.



NO CLAIM IS MADE TO THE EXCLUSIVE RIGHT TO USE "BRANCH BLIND", APART FROM THE MARK AS SHOWN.

THE MARK CONSISTS OF THE WORDING "BRANCH BLIND" IN STYLIZED FORM ABOVE A LEAF AND STEM DESIGN.

FOR FIELD BLINDS USED IN HUNTING; HUNTING BLINDS; HUNTING CAMOUFLAGE USED AS HUNTING BLINDS (U.S. CLS. 22, 23, 38 AND 50).

NANCY CLARKE, EXAMINING ATTORNEY

CLASS 28—(Continued).

SN 85-305,814. JAKKS PACIFIC, INC., MALIBU, CA. FILED 4-27-2011.

IM FAB 2

THE MARK CONSISTS OF STANDARD CHARACTERS WITHOUT CLAIM TO ANY PARTICULAR FONT, STYLE, SIZE, OR COLOR.

FOR HALLOWEEN AND MASQUERADE COSTUMES, AND ACCESSORIES SOLD AS A UNIT IN CONNECTION THEREWITH, NAMELY, MASKS, OVERSHOES, GLOVES, HATS, BELTS, BANDANNAS, PLAYSUITS, HEADWEAR, UNDERWEAR, FOOTWEAR, HOSIERY, AND WIGS; COSTUMES AND COSTUME ACCESSORIES SOLD AS A UNIT IN CONNECTION THEREWITH, NAMELY, PROPS, JEWELRY, HEADWEAR, FOOTWEAR, MASKS; COSTUMES FOR USE IN ROLE-PLAYING GAMES (U.S. CLS. 22, 23, 38 AND 50).

LINDSEY RUBIN, EXAMINING ATTORNEY

SN 85-305,829. JAKKS PACIFIC, INC., MALIBU, CA. FILED 4-27-2011.

ARTSY HEARTSY

THE MARK CONSISTS OF STANDARD CHARACTERS WITHOUT CLAIM TO ANY PARTICULAR FONT, STYLE, SIZE, OR COLOR.

FOR HALLOWEEN AND MASQUERADE COSTUMES, AND ACCESSORIES SOLD AS A UNIT IN CONNECTION THEREWITH, NAMELY, MASKS, OVERSHOES, GLOVES, HATS, BELTS, BANDANNAS, PLAYSUITS, HEADWEAR, UNDERWEAR, FOOTWEAR, HOSIERY, AND WIGS; COSTUMES AND COSTUME ACCESSORIES SOLD AS A UNIT IN CONNECTION THEREWITH, NAMELY, PROPS, JEWELRY, HEADWEAR, FOOTWEAR, MASKS; COSTUMES FOR USE IN ROLE-PLAYING GAMES (U.S. CLS. 22, 23, 38 AND 50).

LINDSEY RUBIN, EXAMINING ATTORNEY

SN 85-310,814. SOUTHERN STATES MARKETING, INC., MARIETTA, GA. FILED 5-3-2011.

Dirt Babies

THE MARK CONSISTS OF STANDARD CHARACTERS WITHOUT CLAIM TO ANY PARTICULAR FONT, STYLE, SIZE, OR COLOR.

NO CLAIM IS MADE TO THE EXCLUSIVE RIGHT TO USE "BABIES", APART FROM THE MARK AS SHOWN.

FOR HOBBY CRAFT KIT PRIMARILY FOR KIDS COMPRISING PLANTER, SEED STARTING POD, PLANTING MIX, SEED PACKETS, PLANTING STICK, GROWTH CHART, AND INSTRUCTIONS (U.S. CLS. 22, 23, 38 AND 50).

KIMBERLY PERRY, EXAMINING ATTORNEY

CLASS 28—(Continued).

SN 85-328,676. MIZUNO USA, INC., NORCROSS, GA. FILED 5-24-2011.

PNP

THE MARK CONSISTS OF STANDARD CHARACTERS WITHOUT CLAIM TO ANY PARTICULAR FONT, STYLE, SIZE, OR COLOR.

FOR BASEBALL BATTING GLOVES; BASEBALL GLOVES (U.S. CLS. 22, 23, 38 AND 50).

ELLEN PERKINS, EXAMINING ATTORNEY

SN 85-328,840. JAMES WILLIAM GEORGE, LAS VEGAS, NV. FILED 5-24-2011.

Toys Bodyboards

THE MARK CONSISTS OF STANDARD CHARACTERS WITHOUT CLAIM TO ANY PARTICULAR FONT, STYLE, SIZE, OR COLOR.

NO CLAIM IS MADE TO THE EXCLUSIVE RIGHT TO USE "BODYBOARDS", APART FROM THE MARK AS SHOWN.

FOR BODY BOARDS (U.S. CLS. 22, 23, 38 AND 50).

FIRST USE 9-24-2006; IN COMMERCE 10-1-2006.

THOMAS MANOR, EXAMINING ATTORNEY

SN 85-333,623. GREGORY E HUETT, SPRINGDALE, AR. FILED 5-31-2011.

BIG COUNTRY TOYS

THE MARK CONSISTS OF STANDARD CHARACTERS WITHOUT CLAIM TO ANY PARTICULAR FONT, STYLE, SIZE, OR COLOR.

NO CLAIM IS MADE TO THE EXCLUSIVE RIGHT TO USE "TOYS", APART FROM THE MARK AS SHOWN.

FOR TOY ANIMALS; TOY ANIMALS AND ACCESSORIES THEREFOR (U.S. CLS. 22, 23, 38 AND 50).

JULIE GUTTADAURO, EXAMINING ATTORNEY

CLASS 28—(Continued).

SN 85-335,507. BUILD-A-BEAR RETAIL MANAGEMENT, INC., ST. LOUIS, MO. FILED 6-1-2011.

PAWPAD

THE MARK CONSISTS OF STANDARD CHARACTERS WITHOUT CLAIM TO ANY PARTICULAR FONT, STYLE, SIZE, OR COLOR.

FOR TOY ACCESSORIES FOR STUFFED AND PLUSH TOYS, NAMELY, A TOY RESEMBLING A TABLET COMPUTER, BUT HAVING NO COMPUTER FUNCTIONALITY (U.S. CLS. 22, 23, 38 AND 50).

RONALD MCMORROW, EXAMINING ATTORNEY

SN 85-343,418. 1-STAR ENTERTAINMENT LLC, GREAT NECK, NY. FILED 6-10-2011.

FYRCRACKYRZ

THE MARK CONSISTS OF STANDARD CHARACTERS WITHOUT CLAIM TO ANY PARTICULAR FONT, STYLE, SIZE, OR COLOR.

FOR TOYS, NAMELY, ACTION FIGURE TOYS, BATH TOYS, BATHTUB TOYS, BATTERY-OPERATED ACTION TOYS, BENDABLE TOYS, COLLECTABLE TOY FIGURES, CONSTRUCTION TOYS, CRIB TOYS, CAT TOYS, DOG TOYS, DRAWING TOYS, ELECTRIC ACTION TOYS, ELECTRONIC LEARNING TOYS, ELECTRIC TOY VEHICLES, ELECTRONICALLY OPERATED TOY MOTOR VEHICLES, FANTASY CHARACTER TOYS, TOY FLYING SAUCERS, INFANT TOYS, MECHANICAL TOYS, MODEL TOY VEHICLES, MODELED PLASTIC TOY FIGURINES, MOLDED TOY FIGURES, MUSIC BOX TOYS, MUSICAL TOYS, NON-ELECTRONIC TOY VEHICLES, PARTY FAVORS IN THE NATURE OF SMALL TOYS, PET TOYS, PLASTIC CHARACTER TOYS, PLAY MATS FOR USE WITH TOY VEHICLES, PLUSH TOYS, POP-UP TOYS, PRINTING TOYS, POSITIONABLE TOY FIGURES, PULL TOYS, PUNCHING TOYS, PUSH TOYS, RADIO-CONTROLLED TOY VEHICLES, RIDEABLE TOY VEHICLES, ROLE PLAYING TOYS IN THE NATURE OF PLAY SETS FOR CHILDREN TO IMITATE REAL LIFE OCCUPATIONS, RUBBER CHARACTER TOYS, SAND TOYS, SANDBOX TOYS, SCALE MODEL KITS, SKETCHING TOYS, SOFT SCULPTURE TOYS, SQUEEZE TOYS, STACKING TOYS, STUFFED AND PLUSH TOYS, STUFFED TOYS, TALKING TOYS, TOSING DISC TOYS, TOY AIRPLANES, TOY AND NOVELTY FACE MASKS, TOY ANIMALS, TOY ARMOR, TOY ARTIFICIAL FINGERNAILS, TOY BAKE-WARE AND COOKWARE, TOY BALLOONS, TOY BANKS, TOY BOATS, TOY BOWS AND ARROWS, TOY BUILDING BLOCKS, TOY BUTTERFLY NETS, TOY CANDY DISPENSERS, TOY CARS, TOY CLOCKS AND WATCHES, TOY CONSTRUCTION BLOCKS, TOY CONSTRUCTION SETS, TOY FIGURES, TOY FILM CARTRIDGES AND VIEWERS, TOY FURNITURE, TOY GLIDERS, TOY HOUSES, TOY MASKS, TOY MICROSCOPES, TOY MOBILES, TOY MODEL TRAIN SETS, TOY MODEL HOBBY-CRAFT KITS, TOY MODELING DOUGH, TOY MUSIC BOXES, TOY PISTOLS, TOY PUTTY, TOY RECORD PLAYERS, TOY ROBOTS, TOY ROCKETS, TOY SCOOTERS, TOY SNOW GLOBES, TOY SWORDS, TOY TELESCOPES, TOY TOOLS, TOY VEHICLES, TOY WATCHES, TOY WATER GLOBES, TOY WEAPONS, TOY WHISTLES, BEAN BAG ANIMALS, TRANSFORMING ROBOTIC TOYS, WATER SQUIRT-

CLASS 28—(Continued).

ING TOYS, WATER TOYS, WIND-UP TOYS, DISC TOSS TOYS, CHILDREN'S MULTIPLE ACTIVITY TOYS, ARTICLES OF CLOTHING FOR TOYS, BABY MULTIPLE ACTIVITY TOYS, CASES FOR TOY VEHICLES, CASES FOR TOY DOLLS, TOY DOLLS, BOARD GAMES, CARD GAMES, HAND-HELD UNITS FOR PLAYING VIDEO GAMES OTHER THAN THOSE ADAPTED FOR USE WITH AN EXTERNAL DISPLAY SCREEN OR MONITOR, PUZZLE GAMES, HAND-HELD UNITS FOR PLAYING ELECTRONIC GAMES OTHER THAN THOSE ADAPTED FOR USE WITH AN EXTERNAL DISPLAY SCREEN OR MONITOR, APPARATUS FOR ELECTRONIC GAMES OTHER THAN THOSE ADAPTED FOR USE WITH AN EXTERNAL DISPLAY SCREEN OR MONITOR, KITES; TOYS, NAMELY, SPINNING TOYS IN THE NATURE OF TOYS OF VARIOUS SHAPES THAT ARE CONNECTED TO STRINGS AND SPIN; LIGHT-UP TOYS, NAMELY, TOYS OF VARIOUS SHAPES THAT LIGHT UP AND ARE CONNECTED TO STRING AND SPIN, ELECTRONIC BUILDING BLOCKS THAT LIGHT UP; MOVING TOYS, NAMELY, TOYS OF VARIOUS SHAPES THAT ARE CONNECTED TO STRINGS AND SPIN AND MOVE, ELECTRONIC TOY VEHICLES; PLASTIC SPINNING TOYS, NAMELY, TOYS OF VARIOUS SHAPES MADE OF PLASTIC THAT ARE CONNECTED TO STRINGS AND SPIN; BATTERY-OPERATED TOYS, NAMELY, TOYS OF VARIOUS SHAPES THAT ARE CONNECTED TO STRINGS AND SPIN; MUSICAL TOYS, NAMELY, TOYS OF VARIOUS SHAPES THAT ARE CONNECTED TO STRINGS AND SPIN, PLUSH ANIMALS THAT PLAY MUSIC, TOY GUITARS, TOY MUSICAL INSTRUMENTS, TOY PIANOS, TOY DRUMS; HANDHELD TOYS, NAMELY, TOYS OF VARIOUS SHAPES THAT ARE CONNECTED TO STRINGS AND SPIN; NOVELTY TOYS, NAMELY, TOYS OF VARIOUS SHAPES THAT ARE CONNECTED TO STRINGS AND SPIN, DISPENSERS OF STREAM MATERIAL; LIGHT-SHOW TOYS, NAMELY, TOYS OF VARIOUS SHAPES THAT ARE CONNECTED TO STRINGS AND SPIN AND LIGHT UP; TOYS WITH HANDLES, NAMELY, TOYS OF VARIOUS SHAPES THAT ARE CONNECTED TO STRING AND SPIN AND HAVE HANDLES; TOYS WITH SOUND, NAMELY, TOYS OF VARIOUS SHAPES THAT ARE CONNECTED TO STRINGS AND SPIN AND MAKE SOUNDS, TALKING TOYS; TOYS WITH MICROPHONES, NAMELY, TOYS OF VARIOUS SHAPES THAT ARE CONNECTED TO STRINGS AND SPIN AND HAVE MICROPHONES; TOYS ON A ROPE, NAMELY, TOYS OF VARIOUS SHAPES THAT ARE CONNECTED TO ROPE AND SPIN; GIRLS' TOYS, NAMELY, DOLLS, FIGURINES, PLUSH TOYS, PLASTIC TOYS, DRESS-UP SETS, ROLE PLAY TOYS; BOY'S TOYS, NAMELY, ACTION FIGURES; ACTION TOYS, NAMELY, ELECTRONIC ACTION TOYS; FIGURINES, NAMELY, MOLDED PLASTIC TOY FIGURINES; CHARACTER TOYS, NAMELY, PLASTIC CHARACTER TOYS AND PLUSH CHARACTER TOYS; TOY WITH BOOK, NAMELY, CHILDREN'S MULTIPLE ACTIVITY TOYS SOLD AS A UNIT WITH PRINTED BOOK; CHILDREN'S GAMES, NAMELY, BOARD GAMES, CARD GAMES, PUZZLE GAMES, AND APPARATUS FOR ELECTRONIC GAMES OTHER THAN THOSE ADAPTED FOR USE WITH AN EXTERNAL DISPLAY SCREEN OR MONITOR; TOY ELECTRONICS, NAMELY, ELECTRONIC EDUCATIONAL GAME MACHINES FOR CHILDREN AND ELECTRONIC NON-EDUCATIONAL GAME MACHINES FOR CHILDREN (U.S. CLS. 22, 23, 38 AND 50).

ROBIN CHOSID, EXAMINING ATTORNEY

CLASS 28—(Continued).

SN 85-387,558. JEFFREY L. COPE, AUGUSTA, GA. FILED 8-2-2011.

FABCADDY

THE MARK CONSISTS OF STANDARD CHARACTERS WITHOUT CLAIM TO ANY PARTICULAR FONT, STYLE, SIZE, OR COLOR.

FOR GOLF ACCESSORIES, NAMELY, HOLDERS SPECIALLY ADAPTED FOR HOLDING GOLF TEES AND HOLDERS SPECIALLY ADAPTED FOR HOLDING GOLF BALL MARKERS (U.S. CLS. 22, 23, 38 AND 50).

JEAN IM, EXAMINING ATTORNEY

SN 85-398,496. TRADEMARK GAMES, INC. DBA TRADEMARK GLOBAL, LORAIN, OH. FILED 8-15-2011.

Trademark Poker

THE MARK CONSISTS OF STANDARD CHARACTERS WITHOUT CLAIM TO ANY PARTICULAR FONT, STYLE, SIZE, OR COLOR.

SEC. 2(F).
FOR GAMING EQUIPMENT, NAMELY, PLAYING CARDS, CHIPS, GAMING TABLES AND GAMING CLOTHS (U.S. CLS. 22, 23, 38 AND 50).

FIRST USE 1-1-2004; IN COMMERCE 1-1-2004.

CARRIE GENOVESE, EXAMINING ATTORNEY

SN 85-399,879. HUNTER, ANDREW, MT. PLEASANT, SC. FILED 8-17-2011.

GOAL LINE STAND

THE MARK CONSISTS OF STANDARD CHARACTERS WITHOUT CLAIM TO ANY PARTICULAR FONT, STYLE, SIZE, OR COLOR.

FOR INFLATABLE TOY IN THE NATURE OF AN INDOOR OR OUTDOOR PLAY STRUCTURE (U.S. CLS. 22, 23, 38 AND 50).

SUSAN STIGLITZ, EXAMINING ATTORNEY

CLASS 28—(Continued).

SN 85-401,852. JIM MCCAFFERTY PRODUCTIONS INC., SANTA ANA, CA. AND JULIE PYNES, CARLSBAD, CA. FILED 8-18-2011.

PURSE-IT

THE MARK CONSISTS OF STANDARD CHARACTERS WITHOUT CLAIM TO ANY PARTICULAR FONT, STYLE, SIZE, OR COLOR.

FOR HOBBY CRAFT SETS FOR MAKING PURSES (U.S. CLS. 22, 23, 38 AND 50).

STEPHANIE ALI, EXAMINING ATTORNEY

SN 85-404,821. JACOBY CUSTOM CUES, INC., NEKOOSA, WI. FILED 8-23-2011.

JACOBY

THE MARK CONSISTS OF STANDARD CHARACTERS WITHOUT CLAIM TO ANY PARTICULAR FONT, STYLE, SIZE, OR COLOR.

FOR POOL CUES (U.S. CLS. 22, 23, 38 AND 50).

FIRST USE 1-1-1985; IN COMMERCE 1-1-1985.

SUE LAWRENCE, EXAMINING ATTORNEY

SN 85-407,440. CLEVELAND INDIANS BASEBALL COMPANY LIMITED PARTNERSHIP, CLEVELAND, OH. FILED 8-25-2011.



THE MARK CONSISTS OF A STYLIZED DESIGN OF A BASEBALL DIAMOND, TWO HELMETS AND A HOCKEY PUCK THAT DISPLAYS THE LETTERS "VS", UNDER THE WORD "INDIANS" IN STYLIZED FONT AND THE WORDS "THE FROZEN DIAMOND FACEOFF" IN STYLIZED FONT, ALL SURROUNDED BY A FRAME IN THE SHAPE OF A BASEBALL FIELD.

FOR TOYS AND SPORTING GOODS, NAMELY HOCKEY PUCKS, HOCKEY STICKS, BASEBALLS, BATS, NAMELY, MINIATURE BASEBALL BATS, BASEBALL BATS, AND HELMETS, NAMELY, MINI BATTING HELMET REPLICAS (U.S. CLS. 22, 23, 38 AND 50).

CHARLES L. JENKINS, EXAMINING ATTORNEY

CLASS 28—(Continued).

SN 85-408,625. PLAYTIME LLC, ENGLEWOOD, CO. FILED 8-26-2011.

PLAYTUFF

THE MARK CONSISTS OF STANDARD CHARACTERS WITHOUT CLAIM TO ANY PARTICULAR FONT, STYLE, SIZE, OR COLOR.

OWNER OF U.S. REG. NOS. 3,731,034, 3,989,099 AND OTHERS.

FOR INDOOR AND OUTDOOR PLAYGROUND EQUIPMENT, NAMELY, THEMED PLAY SYSTEMS, THEMED PLAY CLIMBING STRUCTURES, AND RUBBER COATED PLAY ELEMENTS (U.S. CLS. 22, 23, 38 AND 50).

FIRST USE 6-9-2011; IN COMMERCE 6-30-2011.
MARILYN IZZI, EXAMINING ATTORNEY

CLASS 28—(Continued).

SN 85-413,597. THE HAPPIEST BABY, INC., LOS ANGELES, CA. FILED 9-1-2011.

THE HAPPIEST BABY

THE MARK CONSISTS OF STANDARD CHARACTERS WITHOUT CLAIM TO ANY PARTICULAR FONT, STYLE, SIZE, OR COLOR.

OWNER OF U.S. REG. NOS. 3,318,991, 3,434,465 AND 3,851,032.

NO CLAIM IS MADE TO THE EXCLUSIVE RIGHT TO USE "BABY", APART FROM THE MARK AS SHOWN.

FOR INFANT TOYS, BOARD GAMES, CHILDREN'S EDUCATIONAL TOYS FOR DEVELOPING COUNTING SKILLS, COGNITIVE THINKING, FINE MOTOR SKILLS, AUDITORY PROCESSING SKILLS, VISUAL PROCESSING SKILLS; ELECTRONIC GAMES FOR TEACHING OF CHILDREN; PARENTING SKILLS TOYS AND GAMES TO TEACH PARENTS HOW TO HELP THEIR CHILDREN WITH AUDITORY PROCESSING, COGNITIVE LEARNING, VISUAL PROCESSING, AND DEVELOPMENT OF FINE MOTOR SKILLS (U.S. CLS. 22, 23, 38 AND 50).

WILLIAM JACKSON, EXAMINING ATTORNEY

SN 85-411,900. CHARLES E. REPINE, FAYETTEVILLE, GA. FILED 8-31-2011.

LUREPAL

THE MARK CONSISTS OF STANDARD CHARACTERS WITHOUT CLAIM TO ANY PARTICULAR FONT, STYLE, SIZE, OR COLOR.

FOR FISH HOOK HOLDER AND PROTECTOR, NAMELY, A CASE FOR FISH HOOKS; FISH HOOK STORAGE APPARATUS, NAMELY, A CASE FOR FISH HOOKS; STORAGE APPARATUS COMPRISING HOOKS, SUPPORT ARMS, AND SHELVING SPECIALLY ADAPTED FOR SPORTS EQUIPMENT (U.S. CLS. 22, 23, 38 AND 50).

MARLENE BELL, EXAMINING ATTORNEY

SN 85-414,660. KEEPER SPORTS PRODUCTS, LLC, OCEANSIDE, CA. FILED 9-2-2011.



NO CLAIM IS MADE TO THE EXCLUSIVE RIGHT TO USE "CALIFORNIA BOARD COMPANY", APART FROM THE MARK AS SHOWN.

THE MARK CONSISTS OF THE LARGE, BOLD STYLIZED LETTERING "CBC" ABOVE THE WORDING "CALIFORNIA BOARD COMPANY" IN SMALL STYLIZED LETTERING. TO THE LEFT OF "CBC" IS AN OVAL SHAPE CONTAINING A WAVE DESIGN WHICH, TOGETHER WITH "CBC", IS OUTLINED.

FOR BODY BOARDS, SURF BOARDS, KICK BOARD FLOTATION DEVICES FOR RECREATIONAL USE, STAND UP PADDLE BOARDS, SKIM BOARDS, WAKE BOARDS, AND RELATED ACCESSORIES, NAMELY, LEASHES, SWIM FINS, SURFBOARD AND BOARD FINS, PADDLES, AND BAGS SPECIALLY ADAPTED FOR CARRYING BOARDS USED IN THE PRACTICE OF WATER SPORTS (U.S. CLS. 22, 23, 38 AND 50).

LAURA KOVALSKY, EXAMINING ATTORNEY

CLASS 28—(Continued).

SN 85-417,481. PLAY MECHANIX INC., GLEN ELLYN, IL.
FILED 9-8-2011.

BIG BUCK HD

THE MARK CONSISTS OF STANDARD CHARACTERS WITHOUT CLAIM TO ANY PARTICULAR FONT, STYLE, SIZE, OR COLOR.

OWNER OF U.S. REG. NOS. 2,605,456, 3,436,784 AND OTHERS.

NO CLAIM IS MADE TO THE EXCLUSIVE RIGHT TO USE "HD", APART FROM THE MARK AS SHOWN.

FOR ARCADE GAMES; COIN-OPERATED VIDEO GAMES (U.S. CLS. 22, 23, 38 AND 50).

SANJEEV VOHRA, EXAMINING ATTORNEY

SN 85-422,434. FREMANTLE MEDIA LIMITED, LONDON, ENGLAND, FILED 9-14-2011.

TREE FU TOM

THE MARK CONSISTS OF STANDARD CHARACTERS WITHOUT CLAIM TO ANY PARTICULAR FONT, STYLE, SIZE, OR COLOR.

PRIORITY CLAIMED UNDER SEC. 44(D) ON ERPN CMNTY TM OFC APPLICATION NO. 009871443, FILED 4-6-2011, REG. NO. 009871443, DATED 8-22-2011, EXPIRES 4-6-2021.

FOR GAMES AND PLAYTHINGS, NAMELY, TARGET GAMES, BOARD GAMES AND CARD GAMES, KITES, TOY ACTION FIGURES, DISC-TYPE TOSS TOYS, TOY BOWS AND ARROWS, SPORT BALLS AND PLAYGROUND BALLS, DOLLS, DOLL PLAYSETS, PLUSH TOYS, TOY VEHICLES, TOY BUCKET AND SHOVEL SETS, ROLLER SKATES, TOY MODEL HOBBYCRAFT KITS, TOY ROCKETS, TOY GUNS, TOY HOLSTERS, MUSICAL TOYS, JIGSAW PUZZLES, BADMINTON SETS, BUBBLE MAKING WANDS AND SOLUTION SETS, TOY FIGURINES, TOY BANKS, PUPPETS, TOY BALLOONS, YO-YOS, SKATEBOARDS, TOY SCOOTERS, TOY AND NOVELTY FACE MASKS; HAND-HELD COMPUTER GAME EQUIPMENT WHICH IS SELF CONTAINED AND NOT ADAPTED FOR USE WITH TV RECEIVERS; ELECTRONIC TOYS AND ELECTRONIC GAMES, NAMELY, ELECTRONIC ACTION TOYS, ELECTRONIC LEARNING TOYS, AND ELECTRONIC

CLASS 28—(Continued).

GAMES, NAMELY, HAND HELD UNIT FOR PLAYING ELECTRONIC GAMES, BUT SPECIFICALLY EXCLUDING DICE GAMES AND COMPUTER SOFTWARE GAMES, TABLETOP UNITS FOR PLAYING ELECTRONIC GAMES OTHER THAN IN CONJUNCTION WITH A TELEVISION OR COMPUTER, ARCADE TYPE ELECTRONIC VIDEO GAMES; ELECTRONIC GAMES OTHER THAN THOSE ADAPTED FOR USE WITH TELEVISION RECEIVERS ONLY; DOLLS AND DOLLS' CLOTHING; ACCESSORIES FOR DOLLS; DOLLS' HOUSES; DOLLS' FURNITURE; DOLLS' FURNITURE ACCESSORIES; TEDDY BEARS; TOY ACTION FIGURES; TOY VEHICLES; SCALE MODEL VEHICLES; TOY BUILDING STRUCTURES AND TOY VEHICLE TRACKS; SOFT SCULPTURE TOYS; PLUSH TOYS; BALLOONS; PLAYING CARDS; TOY MASKS; FACE MASKS; PUZZLES; DECORATIONS FOR CHRISTMAS TREES; SKATEBOARDS; PUPPETS; MARIONETTES; PLAYING BALLS, NAMELY, SOCCER BALLS, FOOT BALLS, TENNIS BALLS; KITES; BATS; MARBLES (U.S. CLS. 22, 23, 38 AND 50).

MARK RADEMACHER, EXAMINING ATTORNEY

SN 85-423,321. VICTORY LIGHT USA LLC, FRANKLIN PARK, IL. FILED 9-15-2011.

SILICONE SILLIES

THE MARK CONSISTS OF STANDARD CHARACTERS WITHOUT CLAIM TO ANY PARTICULAR FONT, STYLE, SIZE, OR COLOR.

NO CLAIM IS MADE TO THE EXCLUSIVE RIGHT TO USE "SILICONE", APART FROM THE MARK AS SHOWN.

FOR TOYS, NAMELY, DOLLS AND ACCESSORIES THEREFOR, SOFT SCULPTURE TOYS, TOY ACTION FIGURES AND ACCESSORIES THEREFOR; MODELED PLASTIC TOY FIGURINES, CHILDREN'S MULTIPLE ACTIVITY TOYS (U.S. CLS. 22, 23, 38 AND 50).

DANNEAN HETZEL, EXAMINING ATTORNEY

SN 85-424,112. LEON MINEVICH, DBA TUMBLE BLOCKS, DALLAS, TX. AND JOSH SANCHEZ, DBA TUMBLE BLOCKS, DALLAS, TX. FILED 9-15-2011.

Tumbling Towers

THE MARK CONSISTS OF STANDARD CHARACTERS WITHOUT CLAIM TO ANY PARTICULAR FONT, STYLE, SIZE, OR COLOR.

NO CLAIM IS MADE TO THE EXCLUSIVE RIGHT TO USE "TOWERS", APART FROM THE MARK AS SHOWN.

FOR PUZZLE GAMES (U.S. CLS. 22, 23, 38 AND 50).
FIRST USE 5-1-2011; IN COMMERCE 5-1-2011.

SHAILA SETTLES, EXAMINING ATTORNEY

CLASS 28—(Continued).

SN 85-424,563. PAX RIVER PRODUCTS, LLC, UPPER MARLBORO, MD. FILED 9-16-2011.

Go Natural TreeBranch TreeStand Camo System

THE MARK CONSISTS OF STANDARD CHARACTERS WITHOUT CLAIM TO ANY PARTICULAR FONT, STYLE, SIZE, OR COLOR.

NO CLAIM IS MADE TO THE EXCLUSIVE RIGHT TO USE "TREE BRANCH TREE STAND CAMO SYSTEM", APART FROM THE MARK AS SHOWN.

FOR HUNTING CAMOUFLAGE USED AS HUNTING BLINDS; TREESTANDS FOR HUNTING (U.S. CLS. 22, 23, 38 AND 50).

FIRST USE 8-25-2009; IN COMMERCE 8-25-2009.
KHANH LE, EXAMINING ATTORNEY

SN 85-429,866. MAGEE, THANE, DEL MAR, CA. FILED 9-22-2011.

GRIFFIN SKATEBOARDS

THE MARK CONSISTS OF STANDARD CHARACTERS WITHOUT CLAIM TO ANY PARTICULAR FONT, STYLE, SIZE, OR COLOR.

NO CLAIM IS MADE TO THE EXCLUSIVE RIGHT TO USE "SKATEBOARDS", APART FROM THE MARK AS SHOWN.

FOR SKATEBOARD DECKS; SKATEBOARD GRIP TAPES; SKATEBOARD RAILS; SKATEBOARD TRUCKS; SKATEBOARD WHEELS; SKATEBOARDS (U.S. CLS. 22, 23, 38 AND 50).

FIRST USE 6-1-2011; IN COMMERCE 6-1-2011.
MYRIAH HABEEB, EXAMINING ATTORNEY

SN 85-435,830. SHUFFLE MASTER, INC., LAS VEGAS, NV. FILED 9-29-2011.

MD3

THE MARK CONSISTS OF STANDARD CHARACTERS WITHOUT CLAIM TO ANY PARTICULAR FONT, STYLE, SIZE, OR COLOR.

OWNER OF U.S. REG. NOS. 3,011,454, 4,047,028 AND OTHERS.

FOR CASINO GAMING EQUIPMENT, NAMELY, AUTOMATIC CARD SHUFFLING, IDENTIFYING, VERIFYING AND STORING MACHINES AND SPARE PARTS THEREFOR (U.S. CLS. 22, 23, 38 AND 50).

NANCY CLARKE, EXAMINING ATTORNEY

CLASS 28—(Continued).

SN 85-435,838. SHUFFLE MASTER, INC., LAS VEGAS, NV. FILED 9-29-2011.



OWNER OF U.S. REG. NOS. 3,011,454, 4,047,028 AND OTHERS.

THE MARK CONSISTS OF THE ALPHANUMERIC "MD3" INSIDE AN ANGLED OVAL, AND IN THE BACKGROUND A BOWED "3" OF CLUBS PLAYING CARD.

FOR CASINO GAMING EQUIPMENT, NAMELY, AUTOMATIC CARD SHUFFLING, IDENTIFYING, VERIFYING AND STORING MACHINES AND SPARE PARTS THEREFOR (U.S. CLS. 22, 23, 38 AND 50).

NANCY CLARKE, EXAMINING ATTORNEY

SN 85-437,348. HUNTINFX LLC, CHINA GROVE, NC. FILED 10-2-2011.

Wind-it

THE MARK CONSISTS OF STANDARD CHARACTERS WITHOUT CLAIM TO ANY PARTICULAR FONT, STYLE, SIZE, OR COLOR.

FOR HUNTING EQUIPMENT, NAMELY, WIND DIRECTION INDICATOR, HUNTER'S SCENT CAMOUFLAGE, AND/OR ANIMAL ATTRACTANT SCENTS, EACH IN A SPRAY DISPENSER (U.S. CLS. 22, 23, 38 AND 50).

FIRST USE 10-2-2011; IN COMMERCE 10-2-2011.
SUE LAWRENCE, EXAMINING ATTORNEY

CLASS 28—(Continued).

SN 85-442,179. WILLIS ELECTRIC CO., LTD., SINDIAN CITY, TAIPEI, CHINA, FILED 10-7-2011.

HOLIDAY SHOWTIME

THE MARK CONSISTS OF STANDARD CHARACTERS WITHOUT CLAIM TO ANY PARTICULAR FONT, STYLE, SIZE, OR COLOR.

NO CLAIM IS MADE TO THE EXCLUSIVE RIGHT TO USE "HOLIDAY", APART FROM THE MARK AS SHOWN. FOR ARTIFICIAL CHRISTMAS TREES; PRE-LIT ARTIFICIAL CHRISTMAS TREES (U.S. CLS. 22, 23, 38 AND 50).

SALLY SHIH, EXAMINING ATTORNEY

CLASS 28—(Continued).

SN 85-443,333. WARPED DYNAMICS, WESTLAND, MI. FILED 10-10-2011.

X-zero front heli

THE MARK CONSISTS OF STANDARD CHARACTERS WITHOUT CLAIM TO ANY PARTICULAR FONT, STYLE, SIZE, OR COLOR.

NO CLAIM IS MADE TO THE EXCLUSIVE RIGHT TO USE "HELI", APART FROM THE MARK AS SHOWN.

FOR REMOTE CONTROL TOY GLIDER, AIRPLANE AND SAILPLANE EQUIPMENT, NAMELY, REMOTE CONTROL HELICOPTER (U.S. CLS. 22, 23, 38 AND 50).

ALLISON SCHRODY, EXAMINING ATTORNEY

SN 85-442,344. DALE P. FISHER, HUNTINGTON BEACH, CA. FILED 10-7-2011.

FG USA

THE MARK CONSISTS OF STANDARD CHARACTERS WITHOUT CLAIM TO ANY PARTICULAR FONT, STYLE, SIZE, OR COLOR.

NO CLAIM IS MADE TO THE EXCLUSIVE RIGHT TO USE "USA", APART FROM THE MARK AS SHOWN. FOR GOLF CLUB COVERS; GOLF CLUB HEADS (U.S. CLS. 22, 23, 38 AND 50).

FIRST USE 6-1-1996; IN COMMERCE 6-1-1996. SHANNON TWOHIG, EXAMINING ATTORNEY

SN 85-443,958. BUMMER BEARS, LLC, NEW YORK, NY. FILED 10-11-2011.

MENDEED HEART

THE MARK CONSISTS OF STANDARD CHARACTERS WITHOUT CLAIM TO ANY PARTICULAR FONT, STYLE, SIZE, OR COLOR.

FOR PLUSH TOYS (U.S. CLS. 22, 23, 38 AND 50). FIRST USE 2-15-2009; IN COMMERCE 2-15-2009. JANICE KIM, EXAMINING ATTORNEY

SN 85-443,022. CHRISTY ALTARATZ, CHICAGO, IL. FILED 10-10-2011.

5 STAR DINNER

THE MARK CONSISTS OF STANDARD CHARACTERS WITHOUT CLAIM TO ANY PARTICULAR FONT, STYLE, SIZE, OR COLOR.

NO CLAIM IS MADE TO THE EXCLUSIVE RIGHT TO USE "5 STAR", APART FROM THE MARK AS SHOWN.

FOR BOARD GAMES, CHILDREN'S EDUCATIONAL TOYS FOR DEVELOPING NUTRITIONAL AWARENESS, EQUIPMENT SOLD AS A UNIT FOR PLAYING BOARD GAMES (U.S. CLS. 22, 23, 38 AND 50).

MARGARET POWER, EXAMINING ATTORNEY

SN 85-444,217. HYPRUM, LAFAYETTE, IN. FILED 10-11-2011.

The Party Pine

THE MARK CONSISTS OF STANDARD CHARACTERS WITHOUT CLAIM TO ANY PARTICULAR FONT, STYLE, SIZE, OR COLOR.

NO CLAIM IS MADE TO THE EXCLUSIVE RIGHT TO USE "PINE", APART FROM THE MARK AS SHOWN.

FOR ARTIFICIAL CHRISTMAS TREES (U.S. CLS. 22, 23, 38 AND 50).

TRICIA SONNEBORN, EXAMINING ATTORNEY

CLASS 28—(Continued).

SN 85-445,461. EGRANDBUY, INC, INDUSTRY, CA. FILED 10-12-2011.



NO CLAIM IS MADE TO THE EXCLUSIVE RIGHT TO USE "GEAR RC", APART FROM THE MARK AS SHOWN.

THE MARK CONSISTS OF STYLIZED WORDS "MAD GEAR RC", WITH ONE HALF BIG GEAR SHAPE ON THE TOP OF LETTERS "D" AND "G" ON THE RIGHT TO WHICH THERE IS A HALF SMALL GEAR SHAPE, WITH ANOTHER HALF BIG GEAR SHAPE ON THE BOTTOM OF LETTERS "D" AND "G", AND WITH LETTERS "RC" ON THE RIGHT BOTTOM OF "GEAR", AND WITH ONE BOLD DOT BETWEEN LETTER "D" AND LETTER "G".

FOR REMOTE CONTROL TOYS, NAMELY, HELICOPTERS, CARS, TRUCKS, AIRPLANES, BOATS (U.S. CLS. 22, 23, 38 AND 50).

FIRST USE 1-1-2011; IN COMMERCE 1-1-2011.
JULIE WATSON, EXAMINING ATTORNEY

SN 85-445,487. DUST STUDIO LTD., KOWLOON, HONG KONG, FILED 10-12-2011.

DUST TACTICS

THE MARK CONSISTS OF STANDARD CHARACTERS WITHOUT CLAIM TO ANY PARTICULAR FONT, STYLE, SIZE, OR COLOR.

FOR BOARD GAMES; GAME EQUIPMENT, NAMELY, THREE-DIMENSIONAL MODULAR PIECES FOR ASSEMBLY TO SIMULATE MINIATURE TERRAIN; PLAYING PIECES IN THE NATURE OF MINIATURE ACTION FIGURES AND TOY MODEL VEHICLES FOR USE WITH TABLE TOP HOBBY BATTLE GAMES IN THE NATURE OF BATTLE, WAR AND SKIRMISH GAMES, AND FANTASY GAMES; TABLETOP HOBBY BATTLE GAMES IN THE NATURE OF BATTLE, WAR AND SKIRMISH GAMES, AND FANTASY GAMES, AND PLAYING EQUIPMENT SOLD AS A UNIT THEREWITH (U.S. CLS. 22, 23, 38 AND 50).

FIRST USE 8-5-2011; IN COMMERCE 8-5-2011.
ALICE BENMAMAN, EXAMINING ATTORNEY

CLASS 28—(Continued).

SN 85-445,490. EGRANDBUY, INC, INDUSTRY, CA. AND SHENZHEN DYNAM INDUSTRY & TRADE CO., LTD., YANTIAN, DONGGUAN, CHINA, FILED 10-12-2011.



NO CLAIM IS MADE TO THE EXCLUSIVE RIGHT TO USE "HIGH QUALITY RC PRODUCTS", APART FROM THE MARK AS SHOWN.

THE MARK CONSISTS OF STYLIZED WORDS "DYNAM HIGH QUALITY RC PRODUCTS" INSIDE OVALS, WITH EXTENSION BOLD LINES FROM LETTER "Y" TO THE TOP OF LETTERS "NAM" AND TO THE BOTTOM OF LETTER "D".

FOR REMOTE CONTROL TOYS, NAMELY, HELICOPTERS, AIRPLANES, CARS, TRUCKS, BOATS, AND PARTS AND ACCESSORIES THEREFOR; REMOTE CONTROLLED HOBBY MODEL AIRPLANES, HELICOPTERS, AND COMPONENTS AND ACCESSORIES THEREFOR (U.S. CLS. 22, 23, 38 AND 50).

FIRST USE 1-1-2010; IN COMMERCE 1-1-2010.
JULIE WATSON, EXAMINING ATTORNEY

SN 85-445,653. VITAMIN BLUE, INC, COSTA MESA, CA. FILED 10-12-2011.

VITAMIN BLUE

THE MARK CONSISTS OF STANDARD CHARACTERS WITHOUT CLAIM TO ANY PARTICULAR FONT, STYLE, SIZE, OR COLOR.

NO CLAIM IS MADE TO THE EXCLUSIVE RIGHT TO USE "BLUE", APART FROM THE MARK AS SHOWN.

FOR BAGS ESPECIALLY DESIGNED FOR SURFBOARDS AND PADDLEBOARDS (U.S. CLS. 22, 23, 38 AND 50).

FIRST USE 6-0-2000; IN COMMERCE 6-0-2000.
JOHN WILKE, EXAMINING ATTORNEY

SN 85-445,996. LUCKY CRAFT CO., LTD., OYABE-SHI, TOYAMA, JAPAN, FILED 10-12-2011.

AREA'S

THE MARK CONSISTS OF STANDARD CHARACTERS WITHOUT CLAIM TO ANY PARTICULAR FONT, STYLE, SIZE, OR COLOR.

FOR FISHING LURES; FISHING RODS (U.S. CLS. 22, 23, 38 AND 50).

H. M. FISHER, EXAMINING ATTORNEY

CLASS 28—(Continued).

SN 85-446,059. LUCKY CRAFT CO., LTD., OYABE-SHI, TOYAMA, JAPAN, FILED 10-12-2011.

LVR

THE MARK CONSISTS OF STANDARD CHARACTERS WITHOUT CLAIM TO ANY PARTICULAR FONT, STYLE, SIZE, OR COLOR.

FOR FISHING LURES; FISHING RODS (U.S. CLS. 22, 23, 38 AND 50).
H. M. FISHER, EXAMINING ATTORNEY

CLASS 28—(Continued).

SN 85-446,138. SAMEDI RANCH, L.L.C., LITTLETON, CO. FILED 10-13-2011.

FISHING NOT

THE MARK CONSISTS OF STANDARD CHARACTERS WITHOUT CLAIM TO ANY PARTICULAR FONT, STYLE, SIZE, OR COLOR.

NO CLAIM IS MADE TO THE EXCLUSIVE RIGHT TO USE "FISHING", APART FROM THE MARK AS SHOWN. FOR TERMINAL TACKLE (U.S. CLS. 22, 23, 38 AND 50).

COLLEEN DOMBROW, EXAMINING ATTORNEY

SN 85-446,140. SAMEDI RANCH, L.L.C., LITTLETON, CO. FILED 10-13-2011.

NOT

THE MARK CONSISTS OF STANDARD CHARACTERS WITHOUT CLAIM TO ANY PARTICULAR FONT, STYLE, SIZE, OR COLOR.

FOR TERMINAL TACKLE (U.S. CLS. 22, 23, 38 AND 50).

COLLEEN DOMBROW, EXAMINING ATTORNEY

SN 85-446,130. REES-JONES, BLYTHE, TAURANGA, NEW ZEALAND, FILED 10-12-2011.

natures clip

THE MARK CONSISTS OF STANDARD CHARACTERS WITHOUT CLAIM TO ANY PARTICULAR FONT, STYLE, SIZE, OR COLOR.

FOR ACTION FIGURE TOYS; ARTICLES OF CLOTHING FOR TOYS; BABY MULTIPLE ACTIVITY TOYS; BATHTUB TOYS; BENDABLE TOYS; CAT TOYS; CHILDREN'S ACTIVITY TABLES CONTAINING MANIPULATIVE TOYS WHICH CONVERT TO EASELS; CHILDREN'S EDUCATIONAL TOYS FOR DEVELOPING FINE MOTOR, ORAL LANGUAGE, NUMBERS, COUNTING, COLORS AND ALPHABET SKILLS SOLD IN A FABRIC BAG WHICH HAS A CLEAR VINYL WINDOW FOR VIEWING SMALL TRINKETS AND TOYS SECURELY CONTAINED WITHIN THE BAG ITSELF; CHILDREN'S MULTIPLE ACTIVITY TOYS; CONSTRUCTION TOYS; CRIB TOYS; DOG TOYS; ELECTRIC ACTION TOYS; INFANT ACTION CRIB TOYS; INFANT DEVELOPMENT TOYS; INFANT TOYS; INFLATABLE TOYS; MECHANICAL TOYS; MODEL TOY VEHICLES; MOLDED TOY FIGURES; MUSICAL TOYS; NON-RIDING TRANSPORTATION TOYS; PET TOYS; PLAY MATS CONTAINING INFANT TOYS; PULL TOYS; PUSH TOYS; RIDE-ON TOYS; RIDEABLE TOY VEHICLES; SAND TOYS; SQUEEZE TOYS; STUFFED TOYS; TOY ACTION FIGURES; TOY ANIMALS; TOY ANIMALS AND ACCESSORIES THEREFOR; TOY BOXES; TOY CONSTRUCTION BLOCKS; TOY CONSTRUCTION SETS; TOY FIGURES; TOY FURNITURE; TOY HOUSES; TOY MOBILES (U.S. CLS. 22, 23, 38 AND 50).

FIRST USE 1-10-2009; IN COMMERCE 1-9-2011.

RAUL CORDOVA, EXAMINING ATTORNEY

SN 85-446,434. DRISCOLL, JULIA, A, DBA POLZ, MILTON, MA. FILED 10-13-2011.



THE MARK CONSISTS OF THE WORD "POLZ" WITH STYLIZED WHITE LETTERING AGAINST A BLACK BACKGROUND.

FOR PORTABLE SKI CARRIERS (U.S. CLS. 22, 23, 38 AND 50).

FIRST USE 9-1-2011; IN COMMERCE 10-5-2011.

ARETHA SOMERVILLE, EXAMINING ATTORNEY

CLASS 28—(Continued).

SN 85-446,438. VANDERGRIFF, JON L, PASADENA, CA. FILED 10-13-2011.

zero2nine

THE MARK CONSISTS OF STANDARD CHARACTERS WITHOUT CLAIM TO ANY PARTICULAR FONT, STYLE, SIZE, OR COLOR.
FOR BOARD GAMES (U.S. CLS. 22, 23, 38 AND 50).
ARETHA SOMERVILLE, EXAMINING ATTORNEY

CLASS 28—(Continued).

SN 85-447,115. MIMIK, INC., ENCINITAS, CA. FILED 10-13-2011.

Mimik

THE MARK CONSISTS OF STANDARD CHARACTERS WITHOUT CLAIM TO ANY PARTICULAR FONT, STYLE, SIZE, OR COLOR.
FOR BAGS ESPECIALLY DESIGNED FOR SURFBOARDS; SURFBOARD FINS; SURFBOARD LEASHES; SURFBOARD TRACTION PADS; SURFBOARD WAX; SURFBOARDS (U.S. CLS. 22, 23, 38 AND 50).
WON TEAK OH, EXAMINING ATTORNEY

SN 85-446,716. RISSLER, ROSLYN, LOS GATOS, CA. FILED 10-13-2011.

BLUSKYRIDE

THE MARK CONSISTS OF STANDARD CHARACTERS WITHOUT CLAIM TO ANY PARTICULAR FONT, STYLE, SIZE, OR COLOR.
FOR BICYCLE TRAINERS AND STATIC BICYCLE TRAINERS (U.S. CLS. 22, 23, 38 AND 50).
JAY FLOWERS, EXAMINING ATTORNEY

SN 85-447,139. BOOTYGUARD LLC, MERRICK, NY. FILED 10-13-2011.

BOOTY GUARD

NO CLAIM IS MADE TO THE EXCLUSIVE RIGHT TO USE "BOOTY GUARD", APART FROM THE MARK AS SHOWN.
THE MARK CONSISTS OF THE STYLIZED TEXT "BOOTY GUARD" WITH AN IMAGE OF A SKELETON BETWEEN THE TWO WORDS.
FOR ATHLETIC PROTECTIVE PADS WITH AN ATTACHED BELT WORN FOR PROTECTING THE COCCYX AREA (U.S. CLS. 22, 23, 38 AND 50).
FIRST USE 2-1-2010; IN COMMERCE 9-1-2010.
ALICIA COLLINS, EXAMINING ATTORNEY

SN 85-446,892. WRIGHT & MCGILL CO., DENVER, CO. FILED 10-13-2011.

POWERLIGHT

THE MARK CONSISTS OF STANDARD CHARACTERS WITHOUT CLAIM TO ANY PARTICULAR FONT, STYLE, SIZE, OR COLOR.
FOR (BASED ON USE) FISHING RODS; (BASED ON INTENT TO USE) SWIVELS USED FOR FISHING; REELS USED FOR FISHING (U.S. CLS. 22, 23, 38 AND 50).
FIRST USE 7-0-1996; IN COMMERCE 7-0-1996.
YAT SYE, LEE, EXAMINING ATTORNEY

SN 85-447,169. IDEAS WITH HEART, LLC, PORTLAND, OR. FILED 10-13-2011.

OMG

THE MARK CONSISTS OF STANDARD CHARACTERS WITHOUT CLAIM TO ANY PARTICULAR FONT, STYLE, SIZE, OR COLOR.
FOR PLUSH TOYS; STUFFED AND PLUSH TOYS; STUFFED TOY ANIMALS; STUFFED TOY BEARS; STUFFED TOYS (U.S. CLS. 22, 23, 38 AND 50).
WON TEAK OH, EXAMINING ATTORNEY

CLASS 28—(Continued).

SN 85-447,187. IDEAS WITH HEART, LLC, PORTLAND, OR. FILED 10-13-2011.

OMG FRIENDS!

THE MARK CONSISTS OF STANDARD CHARACTERS WITHOUT CLAIM TO ANY PARTICULAR FONT, STYLE, SIZE, OR COLOR.

FOR PLUSH TOYS; STUFFED AND PLUSH TOYS; STUFFED TOY ANIMALS; STUFFED TOY BEARS; STUFFED TOYS (U.S. CLS. 22, 23, 38 AND 50).
WON TEAK OH, EXAMINING ATTORNEY

SN 85-447,304. THE KYJEN COMPANY, INC., CENTENNIAL, CO. FILED 10-14-2011.

Hide A Bee

THE MARK CONSISTS OF STANDARD CHARACTERS WITHOUT CLAIM TO ANY PARTICULAR FONT, STYLE, SIZE, OR COLOR.

OWNER OF U.S. REG. NO. 3,278,965.
FOR DOG TOYS (U.S. CLS. 22, 23, 38 AND 50).
FIRST USE 1-1-2010; IN COMMERCE 1-1-2010.
KIMBERLY FRYE, EXAMINING ATTORNEY

SN 85-447,346. SPORTSMEN'S OUTDOOR STRATEGIES, LLC, FORKSVILLE, PA. FILED 10-14-2011.

S.O.S-SLAYER

THE MARK CONSISTS OF STANDARD CHARACTERS WITHOUT CLAIM TO ANY PARTICULAR FONT, STYLE, SIZE, OR COLOR.

FOR CROSSBOWS; ARCHERY BOWS ; ARCHERY EQUIPMENT, NAMELY, ARM GUARDS, ARROW FLETCHING DEVICES, BOW CASES, NON-TELESCOPIC BOW SIGHTS, QUIVERS; ARCHERY BOW STRINGS; ARCHERY BOW STRING CHANGERS; ARCHERY ARROWS; ARCHERY SETS; ARCHERY TARGETS (U.S. CLS. 22, 23, 38 AND 50).
IRA J. GOODSAD, EXAMINING ATTORNEY

CLASS 28—(Continued).

SN 85-447,352. SPORTSMEN'S OUTDOOR STRATEGIES, LLC, FORKSVILLE, PA. FILED 10-14-2011.



NO CLAIM IS MADE TO THE EXCLUSIVE RIGHT TO USE "SPORTSMEN'S" OR "PRODUCTS", APART FROM THE MARK AS SHOWN.

THE GRAY IN THE MARK IS FOR SHADING PURPOSES ONLY

THE MARK CONSISTS OF THE WORDING "WALKER'S SPORTSMEN'S OUTDOOR STRATEGIES INNOVATIVE PRODUCTS" INSIDE AN OVAL FORMED BY A SHADED ELLIPTICAL LINE, WITH THE SCENE OF A FLYING BIRD, LEAFLESS TREES AND MOUNTAINS TO THE RIGHT.

FOR CROSSBOWS; ARCHERY BOWS; ARCHERY EQUIPMENT, NAMELY, ARM GUARDS, ARROW FLETCHING DEVICES, BOW CASES, NON-TELESCOPIC BOW SIGHTS, QUIVERS; ARCHERY BOW STRINGS; ARCHERY BOW STRING CHANGERS; ARCHERY ARROWS; ARCHERY SETS; ARCHERY TARGETS (U.S. CLS. 22, 23, 38 AND 50).
IRA J. GOODSAD, EXAMINING ATTORNEY

SN 85-447,365. GAMEBROTHERZ INTELLECTUAL PROPERTY HOLDING INC., MONTREAL, CANADA, FILED 10-14-2011.

THE SOCIAL BOARD

THE MARK CONSISTS OF STANDARD CHARACTERS WITHOUT CLAIM TO ANY PARTICULAR FONT, STYLE, SIZE, OR COLOR.

NO CLAIM IS MADE TO THE EXCLUSIVE RIGHT TO USE "BOARD", APART FROM THE MARK AS SHOWN.

FOR BOARD GAMES; CARD GAMES; DICE GAMES; DOLLS; EDUCATIONAL CARD GAMES; ELECTRONIC GAMES OTHER THAN THOSE ADAPTED FOR USE WITH TELEVISION RECEIVERS ONLY; GAME CARDS; INFLATABLE TOYS; PARLOUR GAMES; PLAYING CARDS; PLUSH TOYS; SOFT SCULPTURE TOYS; STUFFED TOYS; TOY FIGURES (U.S. CLS. 22, 23, 38 AND 50).
DAWN FELDMAN, EXAMINING ATTORNEY

CLASS 28—(Continued).

SN 85-447,846. JIMMIE DEAN CALL, DBA CALL OF THE WILD OUTFITTERS, HUTCHINSON, KS. FILED 10-14-2011.

THE LAST STAND

THE MARK CONSISTS OF STANDARD CHARACTERS WITHOUT CLAIM TO ANY PARTICULAR FONT, STYLE, SIZE, OR COLOR.

FOR TREESTANDS FOR HUNTING (U.S. CLS. 22, 23, 38 AND 50).

SUSAN LESLIE DUBOIS, EXAMINING ATTORNEY

SN 85-447,864. GREATER MIAMI BASEBALL CLUB, L.P., FORT MYERS, FL. FILED 10-14-2011.



NO CLAIM IS MADE TO THE EXCLUSIVE RIGHT TO USE "FORT MYERS", APART FROM THE MARK AS SHOWN.

THE MARK CONSISTS OF A BODY OF WATER WITH A SAILBOAT SAILING TOWARDS A BEACH WITH "FORT MYERS MIRACLE" ABOVE WITH A PALM TREE AND BASEBALL INCORPORATED INTO THE WORDING.

FOR TOYS AND SPORTING GOODS, NAMELY, BALLOONS, BASEBALLS, BASEBALL GLOVES, BASEBALL MITTS, BATTING GLOVES, CATCHERS' MASKS, CHEST PROTECTORS FOR SPORTS, CHRISTMAS TREE ORNAMENTS, DOLLS, FLYING DISCS, GOLF BALLS, INFLATABLE TOY BASEBALL BATS, KITES, MINIATURE BASEBALL BATS, SHIN GUARDS FOR ATHLETIC USE, STUFFED TOY ANIMALS, TOY BASEBALL BATTING HELMETS, TOY NOISEMAKERS AND YO-YOS (U.S. CLS. 22, 23, 38 AND 50).

FIRST USE 10-1-2010; IN COMMERCE 10-1-2010.

EMILY CARLSEN, EXAMINING ATTORNEY

CLASS 28—(Continued).

SN 85-447,966. SMARTBALL, INC., CLEARWATER, FL. FILED 10-14-2011.



THE MARK CONSISTS OF A LEFT POINTING ARROW HEAD WITH THE WORD "SMARTBALL" TO THE RIGHT OF THE ARROW HEAD.

FOR GOLF BALLS; GOLF BALL SLEEVES; GOLF ACCESSORIES, NAMELY, CARRIERS AND DISPENSERS FOR GOLF BALLS; COVERS FOR GOLF CLUBS; GOLF PUTTER COVERS; HEAD COVERS FOR GOLF CLUBS; HAND GRIPS FOR GOLF CLUBS; GRIP TAPES FOR GOLF CLUBS; GLOVES FOR GOLF; DIVOT REPAIR TOOLS; GOLF TEES; GOLF CLUBS; GOLF IRONS; GOLF PUTTERS; GOLF CLUB HEADS; GOLF CLUB SHAFTS; GOLF BAGS WITH OR WITHOUT WHEELS; GOLF CLUB BAGS; GOLF BAG COVERS; TROLLEY BAGS FOR GOLF EQUIPMENT; GOLF ACCESSORY POUCHES; GOLF TOWEL CLIPS FOR ATTACHMENT TO GOLF BAGS; GOLF BAG TAGS; GOLF FLAGS; GOLF BALL RETRIEVERS; GOLF BALL MARKERS; GOLF ACCESSORIES, NAMELY, HOLDERS SPECIALLY ADAPTED FOR HOLDING GOLF BALL MARKERS; IMPACT MARKERS IN THE NATURE OF PRESSURE SENSITIVE REUSABLE IMPACT LABELS FOR ATTACHMENT TO THE HEAD OF A GOLF CLUB TO INDICATE WHERE THE CLUB HITS THE BALL; GOLF CLUB INSERTS; GOLF TEE MARKS; GOLF CLUB SWING AND GOLF PUTTING AIDS, NAMELY, GOLF BALLS WITH INDICIA RELATED TO GOLF SWING, STROKE, OR STRATEGY; ORNAMENTED GOLF BALLS; GOLF PRACTICE NETS; DRIVING PRACTICE MATS; PUTTING PRACTICE MATS; MODULAR PREFABRICATED MINIATURE GOLF COURSES AND PUTTING SURFACES (U.S. CLS. 22, 23, 38 AND 50).

AMY KERTGATE, EXAMINING ATTORNEY

SN 85-448,009. EVANS, BRAD, SIERRA MADRE, CA. FILED 10-14-2011.



THE COLOR(S) RED IS/ARE CLAIMED AS A FEATURE OF THE MARK.

THE MARK CONSISTS OF THE WORD "CORBAG" IN RED BLOCK LETTERS; AN OUTLINE OF A FIGHTER IS IN THE MIDDLE SO THAT THE HEAD OF THE FIGHTER IS THE INSIDE OF THE "O" AND THE LOWER LEG PARTS THE LOWER SECTION OF "R", AN OUTLINE OF A COORDINATION BAG MAKES UP THE HOLES IN THE LETTER "B". THE COLOR WHITE REPRESENTS BACKGROUND AND/OR TRANSPARENT AREAS AND IS NOT PART OF THE MARK.

FOR SPORTING GOODS, NAMELY, A SPORTS TRAINING DEVICE TO IMPROVE STRENGTH, TONING, CONDITIONING, BALANCE, AND PROPRIOCEPTION (U.S. CLS. 22, 23, 38 AND 50).

FIRST USE 10-13-2011; IN COMMERCE 10-14-2011.

MAYUR VAGHANI, EXAMINING ATTORNEY

CLASS 28—(Continued).

SN 85-448,080. APPZILLA LLC, WOODLAND HILLS, CA.
FILED 10-14-2011.



THE MARK CONSISTS OF A "V" SUPERIMPOSED ON AN "M" SO THAT THE BOTTOM OF THE "V" COMPLETES THE MIDDLE PORTION OF THE "M". THE WORDS "VOWEL MOVEMENT" APPEAR UNDER THE DESIGN.
FOR PUZZLE GAMES (U.S. CLS. 22, 23, 38 AND 50).
ROSELLE HERRERA, EXAMINING ATTORNEY

SN 85-448,158. SEBASTIAN GIBSON, AKA RALPH M. GIBSON, PALM DESERT, CA. FILED 10-14-2011.

NITT WITTS

THE MARK CONSISTS OF STANDARD CHARACTERS WITHOUT CLAIM TO ANY PARTICULAR FONT, STYLE, SIZE, OR COLOR.
FOR PLUSH TOYS, NOT FOR ANIMALS; SQUEEZABLE SQUEAKING TOYS, NOT FOR ANIMALS; TALKING TOYS, NOT FOR ANIMALS (U.S. CLS. 22, 23, 38 AND 50).
BERYL GARDNER, EXAMINING ATTORNEY

CLASS 28—(Continued).

SN 85-448,318. REALLY BROTHERS, LLC, NEW YORK, NY.
FILED 10-15-2011.

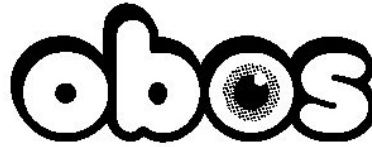

THE MARK CONSISTS OF THE WORD "OBOS" WHEREIN THE SECOND LETTER "O" IS REPRESENTED BY A HUMAN EYE.
THE WORDING "OBOS" HAS NO MEANING IN A FOREIGN LANGUAGE.
FOR COLLECTABLE TOY FIGURES; CONSTRUCTION TOYS; TOY FIGURES (U.S. CLS. 22, 23, 38 AND 50).
ANDREW RHIM, EXAMINING ATTORNEY

SN 85-448,886. LAROSE INDUSTRIES, LLC, RANDOLPH, NJ. FILED 10-17-2011.

SPINZEES

THE MARK CONSISTS OF STANDARD CHARACTERS WITHOUT CLAIM TO ANY PARTICULAR FONT, STYLE, SIZE, OR COLOR.
FOR SPINNING DOLLS AND ACCESSORIES THEREFOR; SPINNING TOY ANIMALS AND ACCESSORIES THEREFOR; PLAYSETS FOR SPINNING DOLLS AND TOY ANIMALS, AND ACCESSORIES THEREFOR; AND TOY PLAYSETS FOR DECORATING HAIR CONSISTING OF HAIR ORNAMENTS, BARRETTES, HAIR CLIPS, HAIR PINS, HAIR BOWS AND HAIR RIBBONS (U.S. CLS. 22, 23, 38 AND 50).
JENNIFER MARTIN, EXAMINING ATTORNEY

SN 85-448,952. MANTON, JUNE, NEW YORK, NY. AND ST JEAN, CATHERINE AVERY, STATEN ISLAND, NY. FILED 10-17-2011.

Bag-A-Head

THE MARK CONSISTS OF STANDARD CHARACTERS WITHOUT CLAIM TO ANY PARTICULAR FONT, STYLE, SIZE, OR COLOR.
FOR FACE MASKS (U.S. CLS. 22, 23, 38 AND 50).
TINA MAI, EXAMINING ATTORNEY

CLASS 28—(Continued).

SN 85-449,223. THE KYJEN COMPANY, INC., CENTENNIAL, CO. FILED 10-17-2011.

Puzzle Plush

THE MARK CONSISTS OF STANDARD CHARACTERS WITHOUT CLAIM TO ANY PARTICULAR FONT, STYLE, SIZE, OR COLOR.

NO CLAIM IS MADE TO THE EXCLUSIVE RIGHT TO USE "PLUSH", APART FROM THE MARK AS SHOWN.

FOR DOG TOYS (U.S. CLS. 22, 23, 38 AND 50).

FIRST USE 1-1-2010; IN COMMERCE 1-1-2010.

KIMBERLY FRYE, EXAMINING ATTORNEY

SN 85-449,349. LAND AMERICA HEALTH & FITNESS CO. LTD, XINGLIN XIAMEN, CHINA, FILED 10-17-2011.

STAIRMILL

THE MARK CONSISTS OF STANDARD CHARACTERS WITHOUT CLAIM TO ANY PARTICULAR FONT, STYLE, SIZE, OR COLOR.

OWNER OF U.S. REG. NO. 1,843,743.

FOR EXERCISE EQUIPMENT, NAMELY, STAIR-STEPPING MACHINES; EXERCISE MACHINES; FITNESS MACHINES AND EQUIPMENT, NAMELY, WEIGHTS, TREADMILLS, ROWING MACHINES, STAIR STEPPING MACHINES, RESISTANCE MACHINES, STATIONARY CYCLES (U.S. CLS. 22, 23, 38 AND 50).

MATTHEW PAPPAS, EXAMINING ATTORNEY

SN 85-449,354. LAND AMERICA HEALTH & FITNESS CO. LTD, XINGLIN XIAMEN, CHINA, FILED 10-17-2011.

CLIMBMILL

THE MARK CONSISTS OF STANDARD CHARACTERS WITHOUT CLAIM TO ANY PARTICULAR FONT, STYLE, SIZE, OR COLOR.

OWNER OF U.S. REG. NO. 1,843,743.

FOR EXERCISE EQUIPMENT, NAMELY, STAIR-STEPPING MACHINES; EXERCISE MACHINES; FITNESS MACHINES AND EQUIPMENT, NAMELY, WEIGHTS, TREADMILLS, ROWING MACHINES, STAIR STEPPING MACHINES, RESISTANCE MACHINES, STATIONARY CYCLES (U.S. CLS. 22, 23, 38 AND 50).

MATTHEW PAPPAS, EXAMINING ATTORNEY

CLASS 28—(Continued).

SN 85-449,503. KWANG GING ENTERPRISE CO., LTD., CHANGHWA HSIEN, TAIWAN, FILED 10-18-2011.

Twinkle

THE MARK CONSISTS OF THE WORD "TWINKLE" WITH THE LAST LETTER "E" GRAPHICALLY DEPICTED AS A FISH THAT ALSO LOOKS LIKE THE LETTER "E".

FOR ANIMAL HUNTING DECOYS; ARTIFICIAL FISHING BAIT; ARTIFICIAL FISHING LURES; BITE INDICATORS; BITE SENSORS; FISHING CREELS; FISHING FLOATS; FISHING HOOKS; FISHING LEADERS; FISHING LINES; FISHING LURE BOXES; FISHING REELS; FISHING ROD HOLDERS; FISHING RODS; FISHING SINKERS; FISHING TACKLE; FISHING TACKLE BAGS; GUT FOR FISHING; HAND-HELD FISHING NETS; LANDING NETS FOR ANGLERS; LURES FOR HUNTING OR FISHING (U.S. CLS. 22, 23, 38 AND 50).

DAVID MURRAY, EXAMINING ATTORNEY

SN 85-449,508. LEPENDOR, MICHELLE M, PRINCETON, NJ. FILED 10-18-2011.



THE COLOR(S) RED, ORANGE, YELLOW, GREEN, TURQUOISE, BLUE AND PURPLE IS/ARE CLAIMED AS A FEATURE OF THE MARK.

THE MARK CONSISTS OF THE LETTERS "M-A-T-H-W-Y-Z" WITH EACH LETTER BEING A DIFFERENT COLOR, SUCH THAT THE "M" IS RED, THE "A" IS ORANGE, THE "T" IS YELLOW, THE "H" IS GREEN, THE SECOND "W" IS TURQUOISE, THE "Y" IS BLUE AND THE "Z" IS PURPLE.

FOR BOARD GAMES (U.S. CLS. 22, 23, 38 AND 50).

SANJEEV VOHRA, EXAMINING ATTORNEY

SN 85-449,623. BURNHAM, TERI, DAMMERON VALLEY, UT. FILED 10-18-2011.

Teri's Toys

THE MARK CONSISTS OF STANDARD CHARACTERS WITHOUT CLAIM TO ANY PARTICULAR FONT, STYLE, SIZE, OR COLOR.

NO CLAIM IS MADE TO THE EXCLUSIVE RIGHT TO USE "TOYS", APART FROM THE MARK AS SHOWN.

FOR CHILDREN'S MULTIPLE ACTIVITY TOYS (U.S. CLS. 22, 23, 38 AND 50).

IRA J. GOODSaid, EXAMINING ATTORNEY

CLASS 28—(Continued).

SN 85-450,134. TUZYANN, SANTA BARBARA, CA. FILED 10-18-2011.

Fact-tions
Tell the true stories of
your life

THE MARK CONSISTS OF STANDARD CHARACTERS WITHOUT CLAIM TO ANY PARTICULAR FONT, STYLE, SIZE, OR COLOR.
FOR BOARD GAMES (U.S. CLS. 22, 23, 38 AND 50).
LINDA E. BLOHM, EXAMINING ATTORNEY

CLASS 28—(Continued).

SN 85-450,390. PRETTY UGLY LLC, EDISON, NJ. AND HORVATH, DAVID, EDISON, NJ. AND KIM, SUN-MIN, EDISON, NJ. FILED 10-18-2011.

NIIMAH

THE MARK CONSISTS OF STANDARD CHARACTERS WITHOUT CLAIM TO ANY PARTICULAR FONT, STYLE, SIZE, OR COLOR.
FOR STUFFED AND PLUSH TOYS (U.S. CLS. 22, 23, 38 AND 50).
FIRST USE 9-14-2011; IN COMMERCE 9-14-2011.
ELI HELLMAN, EXAMINING ATTORNEY

SN 85-450,161. GELB TECHNOLOGIES, LLC, WHITE PLAINS, NY. FILED 10-18-2011.

GEL-B

THE MARK CONSISTS OF STANDARD CHARACTERS WITHOUT CLAIM TO ANY PARTICULAR FONT, STYLE, SIZE, OR COLOR.
FOR MOUTH GUARDS FOR ATHLETIC USE (U.S. CLS. 22, 23, 38 AND 50).
TRACY FLETCHER, EXAMINING ATTORNEY

SN 85-450,392. PRETTY UGLY LLC, EDISON, NJ. AND HORVATH, DAVID, EDISON, NJ. AND KIM, SUN-MIN, EDISON, NJ. FILED 10-18-2011.

TUB NUBURY

THE MARK CONSISTS OF STANDARD CHARACTERS WITHOUT CLAIM TO ANY PARTICULAR FONT, STYLE, SIZE, OR COLOR.
FOR STUFFED AND PLUSH TOYS (U.S. CLS. 22, 23, 38 AND 50).
FIRST USE 9-14-2011; IN COMMERCE 9-14-2011.
ELI HELLMAN, EXAMINING ATTORNEY

SN 85-450,172. TOY STATE INDUSTRIAL LTD., TSIMSHAT-SUI, KOWLOON, HONG KONG, FILED 10-18-2011.

TANKZILLA

THE MARK CONSISTS OF STANDARD CHARACTERS WITHOUT CLAIM TO ANY PARTICULAR FONT, STYLE, SIZE, OR COLOR.
FOR TOY VEHICLES (U.S. CLS. 22, 23, 38 AND 50).
REBECCA POVARCHUK, EXAMINING ATTORNEY

SN 85-451,536. FIFTH STREET GAMING, LLC, LAS VEGAS, NV. FILED 10-19-2011.

DOWNTOWN GRAND

THE MARK CONSISTS OF STANDARD CHARACTERS WITHOUT CLAIM TO ANY PARTICULAR FONT, STYLE, SIZE, OR COLOR.
FOR CARD GAMES; DICE; DICE GAMES; GAMING EQUIPMENT, NAMELY, POKER CHIPS; PLAYING CARDS; ROULETTE WHEELS (U.S. CLS. 22, 23, 38 AND 50).
DAVID HOFFMAN, EXAMINING ATTORNEY

CLASS 28—(Continued).

SN 85-451,559. HANNA-BARBERA PRODUCTIONS, INC., BURBANK, CA. FILED 10-19-2011.



THE MARK CONSISTS OF A DRAWING OF A SMILING BEAR'S HEAD WITH A BOW TIE AT THE NECK WITH THE VERBIAGE "BOO BOO" BELOW THE BEAR'S HEAD.

FOR TOYS AND SPORTING GOODS INCLUDING GAMES AND PLAYTHINGS, NAMELY, ACTION FIGURES AND ACCESSORIES THEREFOR; PLUSH TOYS; BALLOONS; BATHTUB TOYS; RIDE-ON TOYS; EQUIPMENT SOLD AS A UNIT FOR PLAYING CARD GAMES; TOY VEHICLES; DOLLS; FLYING DISCS; ELECTRONIC HAND-HELD GAME UNIT; GAME EQUIPMENT SOLD AS A UNIT FOR PLAYING A BOARD GAME, A CARD GAME, A MANIPULATIVE GAME, A PARLOR GAME AND AN ACTION TYPE TARGET GAME; STAND ALONE VIDEO OUTPUT GAME MACHINES; JIGSAW AND MANIPULATIVE PUZZLES; PAPER FACE MASKS; SKATEBOARDS; ICE SKATES; WATER SQUIRTING TOYS; BALLS, NAMELY, PLAYGROUND BALLS, SOCCER BALLS, BASEBALLS, BASKETBALLS; BASEBALL GLOVES; SWIMMING FLOATS FOR RECREATIONAL USE; KICK BOARD FLOTATION DEVICES FOR RECREATIONAL USE; SURFBOARDS; SWIM BOARDS FOR RECREATIONAL USE; SWIM FINS; TOY BAKEWARE AND TOY COOKWARE; TOY BANKS; TOY SNOW GLOBES; PAPER PARTY HATS; AND CHRISTMAS TREE ORNAMENTS (U.S. CLS. 22, 23, 38 AND 50).
NATALIE POLZER, EXAMINING ATTORNEY

CLASS 28—(Continued).

SN 85-452,687. TWENTIETH CENTURY FOX FILM CORPORATION, LOS ANGELES, CA. FILED 10-20-2011.

CON GARRA

THE MARK CONSISTS OF STANDARD CHARACTERS WITHOUT CLAIM TO ANY PARTICULAR FONT, STYLE, SIZE, OR COLOR.

THE ENGLISH TRANSLATION OF "CON GARRA" IN THE MARK IS "PUNCHY".

FOR CHRISTMAS TREE DECORATIONS; CHRISTMAS TREE ORNAMENTS; HAND HELD UNITS FOR PLAYING ELECTRONIC GAMES OTHER THAN THOSE ADAPTED FOR USE WITH AN EXTERNAL DISPLAY SCREEN OR MONITOR; DOLLS AND DOLL CLOTHING; TOY FIGURES; PLUSH TOYS; BATHTUB TOYS; RUBBER CHARACTER TOYS; BENDABLE TOYS; WIND-UP TOYS; TOY BUILDING BLOCKS; JIGSAW AND MANIPULATIVE PUZZLES; TOY ACTION FIGURES AND ACCESSORIES THEREFOR; ACTION FIGURE PLAY ENVIRONMENTS; PARTY GAMES; PARLOR GAMES; ROLE PLAYING GAMES; BOARD GAMES; ACTION SKILL GAMES; CARD GAMES; PLAYING CARDS; FLYING DISCS; TOY JEWELRY; TOY WATCHES; DART BOARDS; TOY VEHICLES AND ACCESSORIES THEREFOR; SIT-IN AND RIDE-ON TOY VEHICLES; INDOOR PLAY TENTS; HAND HELD PUPPETS; TOY BANKS; WATER SQUIRTING TOYS; TOY PISTOLS; PINBALL AND ARCADE GAME MACHINES; BALLS FOR GAMES; BALLS FOR SPORTS; TENNIS RACKETS; SKATEBOARDS; BALLOONS; HOBBY CRAFT KITS COMPRISED OF TOY FIGURE PLASTIC MOLDS, FASTENERS FOR ATTACHING TOY FIGURE MOLDS, AND DECORATIVE ACCESSORIES FOR MOLDED TOY FIGURES; FLOTATION DEVICES FOR RECREATIONAL USE, NAMELY, INFLATABLE BALLS AND WATER WINGS SWIM AIDS FOR RECREATIONAL USE; COSTUME MASKS (U.S. CLS. 22, 23, 38 AND 50).

JANICE L. MCMORROW, EXAMINING ATTORNEY

SN 85-457,145. DARRELL MCDONALD, IRVING, TX. FILED 10-26-2011.

SLIDEBALL

THE MARK CONSISTS OF STANDARD CHARACTERS WITHOUT CLAIM TO ANY PARTICULAR FONT, STYLE, SIZE, OR COLOR.

FOR SPORTS TRAINING EQUIPMENT, NAMELY, A FLAT CIRCULAR SHAPED APPARATUS USED FOR PHYSICAL FITNESS, ATHLETIC GAMES AND EXERCISE ACTIVITIES (U.S. CLS. 22, 23, 38 AND 50).

FIRST USE 11-1-2010; IN COMMERCE 6-4-2011.
LIEF MARTIN, EXAMINING ATTORNEY

CLASS 28—(Continued).

SN 85-457,354. THE KYJEN COMPANY, INC., CENTENNIAL, CO. FILED 10-27-2011.

IQube

THE MARK CONSISTS OF STANDARD CHARACTERS WITHOUT CLAIM TO ANY PARTICULAR FONT, STYLE, SIZE, OR COLOR.

OWNER OF U.S. REG. NO. 2,677,716.
FOR DOG TOYS (U.S. CLS. 22, 23, 38 AND 50).
FIRST USE 6-1-2010; IN COMMERCE 6-1-2010.
KIMBERLY FRYE, EXAMINING ATTORNEY

SN 85-460,980. THE KYJEN COMPANY, INC., CENTENNIAL, CO. FILED 10-31-2011.

Indestructibles

THE MARK CONSISTS OF STANDARD CHARACTERS WITHOUT CLAIM TO ANY PARTICULAR FONT, STYLE, SIZE, OR COLOR.

FOR DOG TOYS (U.S. CLS. 22, 23, 38 AND 50).
FIRST USE 6-1-2011; IN COMMERCE 6-1-2011.
KIMBERLY FRYE, EXAMINING ATTORNEY

SN 85-466,347. WORLD WRESTLING ENTERTAINMENT, INC., STAMFORD, CT. FILED 11-7-2011.

WWE HOUSE OF FAME

THE MARK CONSISTS OF STANDARD CHARACTERS WITHOUT CLAIM TO ANY PARTICULAR FONT, STYLE, SIZE, OR COLOR.

OWNER OF U.S. REG. NOS. 3,412,176 AND 3,489,357.
FOR TOYS, NAMELY, ACTION FIGURES AND ACCESSORIES THEREFOR; CASES FOR ACTION FIGURES; TOY WRESTLING RINGS; TOY VEHICLES; BOARD GAMES; PLAYING CARDS; PUZZLES; STUFFED TOYS; PLUSH TOYS; TOY BELTS; KNEE AND ELBOW PADS FOR ATHLETIC USE; TOY FOAM HANDS; COSTUME MASKS; DOLLS (U.S. CLS. 22, 23, 38 AND 50).
ALEX KEAM, EXAMINING ATTORNEY

CLASS 28—(Continued).

SN 85-467,050. PRETTY UGLY LLC, EDISON, NJ. AND HORVATH, DAVID, EDISON, NJ. AND KIM, SUN-MIN, EDISON, NJ. FILED 11-8-2011.

BIG BRENNY

THE MARK CONSISTS OF STANDARD CHARACTERS WITHOUT CLAIM TO ANY PARTICULAR FONT, STYLE, SIZE, OR COLOR.

FOR STUFFED AND PLUSH TOYS (U.S. CLS. 22, 23, 38 AND 50).
FIRST USE 10-15-2011; IN COMMERCE 10-15-2011.
ELI HELLMAN, EXAMINING ATTORNEY

SN 85-467,056. PRETTY UGLY LLC, EDISON, NJ. AND HORVATH, DAVID, EDISON, NJ. AND KIM, SUN-MIN, EDISON, NJ. FILED 11-8-2011.

GLARY GLEN

THE MARK CONSISTS OF STANDARD CHARACTERS WITHOUT CLAIM TO ANY PARTICULAR FONT, STYLE, SIZE, OR COLOR.

FOR STUFFED AND PLUSH TOYS (U.S. CLS. 22, 23, 38 AND 50).
FIRST USE 10-15-2011; IN COMMERCE 10-15-2011.
ELI HELLMAN, EXAMINING ATTORNEY

SN 85-467,070. PRETTY UGLY LLC, EDISON, NJ. AND HORVATH, DAVID, EDISON, NJ. AND KIM, SUN-MIN, EDISON, NJ. FILED 11-8-2011.

SMALL TIMER

THE MARK CONSISTS OF STANDARD CHARACTERS WITHOUT CLAIM TO ANY PARTICULAR FONT, STYLE, SIZE, OR COLOR.

FOR STUFFED AND PLUSH TOYS (U.S. CLS. 22, 23, 38 AND 50).
FIRST USE 10-15-2011; IN COMMERCE 10-15-2011.
ELI HELLMAN, EXAMINING ATTORNEY

CLASS 28—(Continued).

SN 85-467,072. PRETTY UGLY LLC, EDISON, NJ. AND HORVATH, DAVID, EDISON, NJ. AND KIM, SUN-MIN, EDISON, NJ. FILED 11-8-2011.

SOGREENO

THE MARK CONSISTS OF STANDARD CHARACTERS WITHOUT CLAIM TO ANY PARTICULAR FONT, STYLE, SIZE, OR COLOR.

FOR STUFFED AND PLUSH TOYS (U.S. CLS. 22, 23, 38 AND 50).

FIRST USE 10-15-2011; IN COMMERCE 10-15-2011.
ELI HELLMAN, EXAMINING ATTORNEY

SN 85-467,289. THANE INTERNATIONAL, INC., LA QUINTA, CA. FILED 11-8-2011.

NANO GYM

THE MARK CONSISTS OF STANDARD CHARACTERS WITHOUT CLAIM TO ANY PARTICULAR FONT, STYLE, SIZE, OR COLOR.

NO CLAIM IS MADE TO THE EXCLUSIVE RIGHT TO USE "NANO", APART FROM THE MARK AS SHOWN.

FOR MANUALLY-OPERATED EXERCISE EQUIPMENT (U.S. CLS. 22, 23, 38 AND 50).

JILL PRATER, EXAMINING ATTORNEY

SN 85-467,700. THE KYJEN COMPANY, INC., CENTENNIAL, CO. FILED 11-8-2011.

Plush Buddies

THE MARK CONSISTS OF STANDARD CHARACTERS WITHOUT CLAIM TO ANY PARTICULAR FONT, STYLE, SIZE, OR COLOR.

NO CLAIM IS MADE TO THE EXCLUSIVE RIGHT TO USE "PLUSH", APART FROM THE MARK AS SHOWN.

FOR DOG TOYS (U.S. CLS. 22, 23, 38 AND 50).

FIRST USE 6-15-1997; IN COMMERCE 6-15-1997.

KIMBERLY FRYE, EXAMINING ATTORNEY

CLASS 28—(Continued).

SN 85-469,770. KEEPER SPORTS PRODUCTS, LLC, OCEANSIDE, CA. FILED 11-10-2011.



NO CLAIM IS MADE TO THE EXCLUSIVE RIGHT TO USE "SLEDS", APART FROM THE MARK AS SHOWN.

THE MARK CONSISTS OF CONCENTRIC OVALS WITH SINGLE BRUSH STROKE ABOVE AND BELOW WITH STYLIZED WORD "SLEDZ" SUPERIMPOSED.

FOR SNOW SLEDS FOR RECREATIONAL USE; SNOW SAUCERS (U.S. CLS. 22, 23, 38 AND 50).

LAURA KOVALSKY, EXAMINING ATTORNEY

SN 85-470,359. EGRANDBUY, INC, INDUSTRY, CA. FILED 11-11-2011.



NO CLAIM IS MADE TO THE EXCLUSIVE RIGHT TO USE "ADVANCED", APART FROM THE MARK AS SHOWN.

THE MARK CONSISTS OF STYLIZED WORDS "ADVANCED MINIAIR", WITH WEBSITE NAME "WWW.MINIAIR-RC.COM" UNDER THE WORD "AIR", WITH WORD "ADVANCED" ON TOP OF "MINI", WITH A SHORT DASH BETWEEN "MINI" AND "AIR", WITH CURVED LINE AROUND WORDS "ADVANCED MINI", AND WITH THREE BOLD CURVED LINES ON TOP OF SECOND "I" IN THE WORD "MINI".

FOR REMOTE CONTROL TOYS, NAMELY, HELICOPTERS, AIRPLANES, CARS, TRUCKS (U.S. CLS. 22, 23, 38 AND 50).

FIRST USE 1-1-2011; IN COMMERCE 1-1-2011.

JULIE WATSON, EXAMINING ATTORNEY

SN 85-470,908. PRETTY UGLY LLC, EDISON, NJ. AND HORVATH, DAVID, EDISON, NJ. AND KIM, SUN-MIN, EDISON, NJ. FILED 11-11-2011.

CROUDY

THE MARK CONSISTS OF STANDARD CHARACTERS WITHOUT CLAIM TO ANY PARTICULAR FONT, STYLE, SIZE, OR COLOR.

FOR STUFFED AND PLUSH TOYS (U.S. CLS. 22, 23, 38 AND 50).

FIRST USE 11-4-2011; IN COMMERCE 11-4-2011.

ELI HELLMAN, EXAMINING ATTORNEY

CLASS 28—(Continued).

SN 85-470,912. PRETTY UGLY LLC, EDISON, NJ. AND HORVATH, DAVID, EDISON, NJ. AND KIM, SUN-MIN, EDISON, NJ. FILED 11-11-2011.

BRIP DRIP

THE MARK CONSISTS OF STANDARD CHARACTERS WITHOUT CLAIM TO ANY PARTICULAR FONT, STYLE, SIZE, OR COLOR.

FOR STUFFED AND PLUSH TOYS (U.S. CLS. 22, 23, 38 AND 50).

FIRST USE 11-4-2011; IN COMMERCE 11-4-2011.
ELI HELLMAN, EXAMINING ATTORNEY

SN 85-474,542. SOURCE INTERLINK MAGAZINES, LLC, EL SEGUNDO, CA. FILED 11-16-2011.

MUD LIFE

THE MARK CONSISTS OF STANDARD CHARACTERS WITHOUT CLAIM TO ANY PARTICULAR FONT, STYLE, SIZE, OR COLOR.

OWNER OF U.S. REG. NO. 3,748,352.
FOR REMOTE CONTROL TOYS, NAMELY, VEHICLES; TOY VEHICLE TRACK SETS AND ROADWAYS AND ACCESSORIES THEREFOR; TOY VEHICLES (U.S. CLS. 22, 23, 38 AND 50).
FONG HSU, EXAMINING ATTORNEY

SN 85-478,379. THE KYJEN COMPANY, INC., CENTENNIAL, CO. FILED 11-21-2011.

Tuff Ones

THE MARK CONSISTS OF STANDARD CHARACTERS WITHOUT CLAIM TO ANY PARTICULAR FONT, STYLE, SIZE, OR COLOR.

FOR DOG TOYS (U.S. CLS. 22, 23, 38 AND 50).
FIRST USE 1-1-2010; IN COMMERCE 1-1-2010.
KIMBERLY FRYE, EXAMINING ATTORNEY

CLASS 28—(Continued).

SN 85-478,803. R&R GAMES, INC., TAMPA, FL. FILED 11-22-2011.

TICKED OFF

THE MARK CONSISTS OF STANDARD CHARACTERS WITHOUT CLAIM TO ANY PARTICULAR FONT, STYLE, SIZE, OR COLOR.

FOR BOARD GAMES (U.S. CLS. 22, 23, 38 AND 50).
KATHRYN COWARD, EXAMINING ATTORNEY

SN 85-479,695. HERSHEY CHOCOLATE & CONFECTIONERY CORPORATION, WHEAT RIDGE, CO. FILED 11-23-2011.

KRACKEL

THE MARK CONSISTS OF STANDARD CHARACTERS WITHOUT CLAIM TO ANY PARTICULAR FONT, STYLE, SIZE, OR COLOR.

OWNER OF U.S. REG. NOS. 703,315, 1,280,490 AND 3,732,677.
FOR TOY TRAINS AND PARTS AND ACCESSORIES THEREFOR (U.S. CLS. 22, 23, 38 AND 50).
LAURIE KAUFMAN, EXAMINING ATTORNEY

SN 85-480,670. LAROSE INDUSTRIES, LLC, RANDOLPH, NJ. FILED 11-24-2011.

MAGRIFIC

THE MARK CONSISTS OF STANDARD CHARACTERS WITHOUT CLAIM TO ANY PARTICULAR FONT, STYLE, SIZE, OR COLOR.

FOR CONSTRUCTION TOYS; TOY CONSTRUCTION SETS; TOY CONSTRUCTION BLOCKS (U.S. CLS. 22, 23, 38 AND 50).
JENNIFER MARTIN, EXAMINING ATTORNEY

CLASS 28—(Continued).

SN 85-480,672. LAROSE INDUSTRIES, LLC, RANDOLPH, NJ. FILED 11-24-2011.

MAG-RIFIC

THE MARK CONSISTS OF STANDARD CHARACTERS WITHOUT CLAIM TO ANY PARTICULAR FONT, STYLE, SIZE, OR COLOR.

FOR CONSTRUCTION TOYS; TOY CONSTRUCTION SETS; TOY CONSTRUCTION BLOCKS (U.S. CLS. 22, 23, 38 AND 50).

JENNIFER MARTIN, EXAMINING ATTORNEY

SN 85-480,673. LAROSE INDUSTRIES, LLC, RANDOLPH, NJ. FILED 11-24-2011.

IT'S MAGRIFIC

THE MARK CONSISTS OF STANDARD CHARACTERS WITHOUT CLAIM TO ANY PARTICULAR FONT, STYLE, SIZE, OR COLOR.

FOR CONSTRUCTION TOYS; TOY CONSTRUCTION SETS; TOY CONSTRUCTION BLOCKS (U.S. CLS. 22, 23, 38 AND 50).

JENNIFER MARTIN, EXAMINING ATTORNEY

SN 85-482,803. TOY STATE INDUSTRIAL LTD., TSIMSHAT-SUI, KOWLOON, HONG KONG, FILED 11-29-2011.

DJZ

THE MARK CONSISTS OF STANDARD CHARACTERS WITHOUT CLAIM TO ANY PARTICULAR FONT, STYLE, SIZE, OR COLOR.

FOR TOY VEHICLES (U.S. CLS. 22, 23, 38 AND 50).

REBECCA POVARCHUK, EXAMINING ATTORNEY

CLASS 28—(Continued).

SN 85-486,891. LAROSE INDUSTRIES, LLC, RANDOLPH, NJ. FILED 12-5-2011.

MAG-CREATOR

THE MARK CONSISTS OF STANDARD CHARACTERS WITHOUT CLAIM TO ANY PARTICULAR FONT, STYLE, SIZE, OR COLOR.

FOR CONSTRUCTION TOYS; TOY CONSTRUCTION SETS; TOY CONSTRUCTION BLOCKS (U.S. CLS. 22, 23, 38 AND 50).

JENNIFER MARTIN, EXAMINING ATTORNEY

SN 85-491,604. EGRANDBUY, INC, INDUSTRY, CA. FILED 12-9-2011.



THE MARK CONSISTS OF STYLIZED WORDS "AEROSKY" ABOVE WHICH THERE IS A PLANE SHAPE.

FOR REMOTE CONTROL TOYS, NAMELY, AIRPLANES, HELICOPTERS, AND ACCESSORIES THEREFOR; REMOTE CONTROLLED HOBBY MODEL AIRPLANES, HELICOPTERS, AND ACCESSORIES THEREFOR (U.S. CLS. 22, 23, 38 AND 50).

FIRST USE 1-1-2011; IN COMMERCE 1-1-2011.

JULIE WATSON, EXAMINING ATTORNEY

SN 85-491,620. EGRANDBUY, INC, INDUSTRY, CA. FILED 12-9-2011.



NO CLAIM IS MADE TO THE EXCLUSIVE RIGHT TO USE "RC", APART FROM THE MARK AS SHOWN.

THE MARK CONSISTS OF STYLIZED WORDS "AIR WING RC", WITH WEBSITE NAME "WWW.AIRWING.COM" ON THE BOTTOM, AND WITH FIVE BLADE SHAPES IN DIFFERENT SIZE FORMING THE SHAPE OF A WING UNDERNEATH THE WORDS.

FOR REMOTE CONTROL TOYS, NAMELY, AIRPLANES, HELICOPTERS, AND ACCESSORIES THEREFOR; REMOTE CONTROLLED HOBBY MODEL AIRPLANES, HELICOPTERS, AND ACCESSORIES THEREFOR (U.S. CLS. 22, 23, 38 AND 50).

FIRST USE 1-1-2011; IN COMMERCE 1-1-2011.

JULIE WATSON, EXAMINING ATTORNEY

CLASS 28—(Continued).

SN 85-491,639. EGRANDBUY, INC, INDUSTRY, CA. FILED 12-9-2011.



THE MARK CONSISTS OF STYLIZED WORDS "DIMENSION" SUPERIMPOSED OVER "V" SHAPE WITH LINES FORMING WINGS.

FOR RADIO-CONTROLLED TOY PARTS, NAMELY, TRANSMITTERS, RECEIVERS, SERVOS, MOTORS AND ELECTRONIC SPEED CONTROLLERS (U.S. CLS. 22, 23, 38 AND 50).

FIRST USE 1-1-2011; IN COMMERCE 1-1-2011.
JULIE WATSON, EXAMINING ATTORNEY

SN 85-517,661. STRATEGIC MARKETING, INC., DUBLIN, OH. FILED 1-17-2012.

UNITED WE STAND

THE MARK CONSISTS OF STANDARD CHARACTERS WITHOUT CLAIM TO ANY PARTICULAR FONT, STYLE, SIZE, OR COLOR.

FOR BOARD GAMES; WORD GAMES PLAYED WITH CARDS (U.S. CLS. 22, 23, 38 AND 50).

JOHN WILKE, EXAMINING ATTORNEY

SN 85-517,662. STRATEGIC MARKETING, INC., DUBLIN, OH. FILED 1-17-2012.

Hoy's Toys

THE MARK CONSISTS OF STANDARD CHARACTERS WITHOUT CLAIM TO ANY PARTICULAR FONT, STYLE, SIZE, OR COLOR.

NO CLAIM IS MADE TO THE EXCLUSIVE RIGHT TO USE "TOYS", APART FROM THE MARK AS SHOWN.

FOR BOARD GAMES; WORD GAMES PLAYED WITH CARDS (U.S. CLS. 22, 23, 38 AND 50).

JOHN WILKE, EXAMINING ATTORNEY

CLASS 29—MEATS AND PROCESSED FOODS

SN 77-295,904. NATURAL HEALTH CORPORATION, MIAMI, FL. FILED 10-4-2007.

PARADISSO

THE MARK CONSISTS OF THE WORD "PARADISSO" IN OUTLINED UPPERCASE LETTERS.

FOR COOKING OIL (U.S. CL. 46).
ANDREA HACK, EXAMINING ATTORNEY

SN 79-101,042. AGRUPACIO DE COOPERATIVES D'OLI DEL MONTSIA, S.C.C.L., ULLDECONA (TARRAGONA), SPAIN, FILED 7-15-2011.

" ACOMONT "

THE MARK CONSISTS OF STANDARD CHARACTERS WITHOUT CLAIM TO ANY PARTICULAR FONT, STYLE, SIZE, OR COLOR.

OWNER OF INTERNATIONAL REGISTRATION 1086753 DATED 7-15-2011, EXPIRES 7-15-2021.

THE WORDING "ACOMONT" HAS NO MEANING IN A FOREIGN LANGUAGE.

FOR EDIBLE OILS (U.S. CL. 46).
MARLENE BELL, EXAMINING ATTORNEY

SN 79-101,044. AGRUPACIO DE COOPERATIVES D'OLI DEL MONTSIA, S.C.C.L., ULLDECONA (TARRAGONA), SPAIN, FILED 7-15-2011.

1000 TARDORS

THE MARK CONSISTS OF STANDARD CHARACTERS WITHOUT CLAIM TO ANY PARTICULAR FONT, STYLE, SIZE, OR COLOR.

OWNER OF INTERNATIONAL REGISTRATION 1086755 DATED 7-15-2011, EXPIRES 7-15-2021.

THE WORDING "TARDORS" HAS NO MEANING IN A FOREIGN LANGUAGE.

FOR EDIBLE OILS (U.S. CL. 46).
MARLENE BELL, EXAMINING ATTORNEY

SN 79-105,404. KAVIARI SAS, FRANCE, FILED 2-9-2011.

KAVIARI

OWNER OF INTERNATIONAL REGISTRATION 0776452 DATED 1-4-2002, EXPIRES 1-4-2022.

THE WORDING "KAVIARI" HAS NO MEANING IN A FOREIGN LANGUAGE.

FOR CAVIAR, FISH, CRUSTACEANS (U.S. CL. 46).
BILL DAWE, EXAMINING ATTORNEY

CLASS 29—(Continued).

SN 79-106,040. ANDREAS PAULSSON, SWEDEN, FILED 10-24-2011.

Goikebiergu

THE MARK CONSISTS OF STANDARD CHARACTERS WITHOUT CLAIM TO ANY PARTICULAR FONT, STYLE, SIZE, OR COLOR.

OWNER OF INTERNATIONAL REGISTRATION 1098896 DATED 10-24-2011, EXPIRES 10-24-2021.

THE WORDING "GOIKEBIERGU" HAS NO MEANING IN A FOREIGN LANGUAGE.

FOR MEAT; SALTED MEAT (U.S. CL. 46).
TOBY BULLOFF, EXAMINING ATTORNEY

SN 85-067,021. EDGAR HUGO, AVENTURA, FL. FILED 6-19-2010.

INUIT CANDY

THE MARK CONSISTS OF STANDARD CHARACTERS WITHOUT CLAIM TO ANY PARTICULAR FONT, STYLE, SIZE, OR COLOR.

NO CLAIM IS MADE TO THE EXCLUSIVE RIGHT TO USE "INUIT", APART FROM THE MARK AS SHOWN.

FOR SALMON FISH FROM INUIT (U.S. CL. 46).
ZACHARY BELLO, EXAMINING ATTORNEY

SN 85-131,471. COLORADO BOXED BEEF CO., AUBURN-DALE, FL. FILED 9-16-2010.



NO CLAIM IS MADE TO THE EXCLUSIVE RIGHT TO USE "ANGUS", APART FROM THE MARK AS SHOWN.

THE MARK CONSISTS OF THE WORDS "HIGH RIVER ANGUS", A HEAD OF CATTLE AND ITS REFLECTION, AND A MOUNTAIN SCENE.

FOR ANGUS BEEF (U.S. CL. 46).
FIRST USE 7-17-2010; IN COMMERCE 7-17-2010.
GEORGE LORENZO, EXAMINING ATTORNEY

CLASS 29—(Continued).

SN 85-154,701. LUISSIER BORDEAU CHESNEL, CHAMPAGNE, FRANCE, FILED 10-18-2010.

BORDEAU-CHESNEL

THE MARK CONSISTS OF STANDARD CHARACTERS WITHOUT CLAIM TO ANY PARTICULAR FONT, STYLE, SIZE, OR COLOR.

OWNER OF FRANCE REG. NO. 1557520, DATED 10-27-1989, EXPIRES 10-26-2019.

OWNER OF U.S. REG. NOS. 2,966,666 AND 3,676,622.
THE WORDING "BORDEAU CHESNEL" HAS NO MEANING IN A FOREIGN LANGUAGE.

FOR MEAT, FISH, POULTRY AND GAME; MEAT EXTRACTS; CHARCUTERIE AND SALTED MEAT PRODUCTS, NAMELY, SAUSAGES, RILLETES, LIVER AND MEAT PATES; READY-COOKED DISHES MADE FROM MEAT, FISH, POULTRY AND GAME (U.S. CL. 46).

REBECCA POVARCHUK, EXAMINING ATTORNEY

SN 85-255,423. NDR LIUZZI, INC., DBA LIUZZIANGELONI CHEESE, HAMDEN, CT. FILED 3-2-2011.



NO CLAIM IS MADE TO THE EXCLUSIVE RIGHT TO USE "SINCE 1981", "CHEESE", "FIOR DI LATTE", "AMERICAN CHEESE SOCIETY", AND "AWARD WINNING 2007", APART FROM THE MARK AS SHOWN.

THE NAME "LIUZZI ANGELONI" DOES NOT IDENTIFY A LIVING INDIVIDUAL.

THE COLOR(S) RED, GREEN & WHITE IS/ARE CLAIMED AS A FEATURE OF THE MARK.

THE MARK CONSISTS OF A GREEN AND WHITE SCENE DEPICTING A GRAZING COW IN A PASTORAL SETTING FEATURING A FIELD AND FARM BUILDINGS; BENEATH THE GRAZING COW SCENE APPEARS THE RED AND WHITE WORDING "LIUZZI ANGELONI" APPEARING BETWEEN GREEN HORIZONTAL LINES; BELOW THIS APPEARS THE WORDING "CHEESE" IN GREEN AND RED AND FLANKED ON EITHER SIDE BY GREEN ORNAMENTAL LEAF DESIGNS; BELOW "CHEESE" APPEARS THE WORDING "BONTA DILATTE" IN STYLIZED GREEN SCRIPT; ALL OF THE AFOREMENTIONED APPEARS WITHIN AN OVAL BORDER DESIGN IN THE COLORS RED, WHITE, AND GREEN; THE WHITE WORDING "SINCE 1981" APPEARS IN A SMALL GREEN RECTANGULAR BACKGROUND HAVING ROUNDED CORNERS AND A RED BORDER, WITH THE WORDING AND BACKGROUND DESIGN BEING INSET IN THE UPPER PORTION OF THE AFOREMENTIONED OVAL BORDER; ACROSS THE BOTTOM EDGE OF THE OVAL BORDER DESIGN APPEARS THE WHITE WORDING "FIOR DI LATTE" UPON A RED BANNER WITH A GREEN BORDER; AT THE RIGHT AND LEFT ENDS OF THE BANNER APPEAR GREEN BASIL LEAVES AND CHEESE OVAL DESIGNS IN THE COLORS WHITE AND GREEN; AT THE BOTTOM LEFT OF THE MARK APPEARS A GREEN, WHITE, AND RED CIRCULAR BORDER WITHIN WHICH APPEARS THE GREEN AND RED WORDING "AMERICAN

CLASS 29—(Continued).

CHEESE SOCIETY" IN THE UPPER PORTION OF A WHITE BACKGROUND AREA AND THE GREEN AND RED WORDING "2007" APPEARING ON THE LOWER PORTION OF A WHITE BACKGROUND AREA; IN THE CENTER OF THE CIRCULAR BORDER AREA APPEARS A SMALLER CIRCLE WITH A GREEN BORDER AND RED BACKGROUND AND WITHIN WHICH APPEARS THE DESIGN OF A CHEESE WEDGE AND A CHEESE-CORING TOOL IN THE COLORS WHITE AND GREEN, WITH THE WEDGE AND TOOL FLANKED BY GREEN LEAVES; THE WHITE WORDING "AWARD WINNING" APPEARS ON A RED AND GREEN BANNER DESIGN APPEARING BENEATH THE CHEESE WEDGE DESIGN; A RED AND WHITE RIBBON DESIGN EXTENDS FROM THE BOTTOM OF THE OUTER CIRCULAR BORDER.

THE ENGLISH TRANSLATION OF "BONTA DI LATTE" IN THE MARK IS THE GOODNESS OF MILK AND THE ENGLISH TRANSLATION OF "FIOR DI LATTE" IN THE MARK IS THE FLOWER OF MILK.

FOR CHEESE; FRESH UNRIPENED CHEESES (U.S. CL. 46).

FIRST USE 6-1-2010; IN COMMERCE 6-1-2010.
KEVIN CORWIN, EXAMINING ATTORNEY

SN 85-285,664. DELICIOUS WORLD CORP., STATEN ISLAND, NY. FILED 4-4-2011.



THE MARK CONSISTS OF THE LETTER "D" AND THE LETTER "W", WITH SHADING TO GIVE THE LETTERS A 3-DIMENSIONAL APPEARANCE, AS WELL AS AN IMAGE OF A GLOBE. THE LETTER "D" IS POSITIONED AT A TILTED 3-DIMENSIONAL ANGLE AND PARTIALLY SUPERIMPOSED OVER THE LETTER "W", WITH THE TOP PORTION OF THE LETTER "W" APPEARING WITHIN THE CENTER OF THE LETTER "D", SO AS TO GIVE THE IMPRESSION THAT THE LETTER "D" IS RESTING ON TOP OF AND AROUND THE LETTER "W". THE IMAGE OF THE GLOBE APPEARS OVER THE CENTER OF THE LETTER "W" AND WITHIN THE CENTER OF THE LETTER "D".

FOR ALBUMEN FOR FOOD, ALGINATES FOR FOOD IN THE NATURE OF DRIED EDIBLE ALGAE, GROUND ALMONDS, ANIMAL MARROW FOR FOOD, APPLE PUREE, BACON, PRESERVED PROCESSED BEANS, BLACK PUDDING, BLOOD SAUSAGE, EDIBLE BONE OIL, BOUILLON, BOUILLON CONCENTRATES, PREPARATIONS FOR MAKING BOUILLON, BROTH, BROTH CONCENTRATES, BUTTER, CHOCOLATE NUT BUTTER, COCOA BUTTER, COCONUT BUTTER, PEANUT BUTTER, CASEIN FOR FOOD, CHARCUTERIE, CHEESE, FRUIT CHIPS, POTATO CHIPS, DESICCATED COCONUT, COCONUT FAT, COCONUT OIL, COLZA OIL FOR FOOD, CORN OIL, CRANBERRY SAUCE, CREAM, WHIPPED CREAM, POTATO CRISPS, CRYSTALLIZED FRUITS, CURD, PROCESSED DATES, EDIBLE BIRDS' NESTS, EDIBLE FATS, EDIBLE OILS, EGGS, POWDERED EGGS, SNAIL EGGS FOR HUMAN CONSUMPTION, FAT-CONTAINING MIXTURES FOR BREAD SLICES IN THE NATURE OF HAZELNUT SPREAD, FATTY SUBSTANCES FOR THE MANUFACTURE OF EDIBLE FATS, FERMENTED VEGETABLE FOODS, POTATO FLAKES IN THE NATURE OF PROCESSED POTATOES, FROSTED FRUITS, FROZEN

CLASS 29—(Continued).

FRUITS, FRUIT JELLIES NOT BEING CONFECTIONERY, FRUIT PEEL, RESERVED FRUIT, FRUIT PRESERVED IN ALCOHOL, FRUIT PULP, FRUIT SALADS, STEWED FRUITS, FRUIT-BASED SNACK FOOD, GAME NOT LIVE, UNFLAVORED GELATIN FOR FOOD, GHERKINS, GINGER JAM, HAM, HERRINGS NOT LIVE, HUMMUS, ISINGLASS FOR FOOD, JAMS, JELLIES FOR FOOD, VEGETABLE JUICE FOR COOKING, KEFIR, KOUMISS, LARD FOR FOOD, TOASTED LIVER, PRESERVED LENTILS, LIVER, LIVER PÂTE, MAIZE OIL, MARGARINE, MARMALADE, MEAT, MEAT EXTRACTS, MEAT JELLIES, PRESERVED MEAT, TINNED MEAT, SALTED MEAT, PROCESSED MUSHROOMS, PREPARED NUTS, OLIVE OIL FOR FOOD, PRESERVED OLIVES, PRESERVED ONIONS, OYSTERS NOT LIVE, PALM KERNEL OIL FOR FOOD, PALM OIL FOR FOOD, LIVER PASTE, PROCESSED PEANUTS, PRESERVED PEAS, PECTIN FOR FOOD, FRUIT PEEL, PICCALILLI, PICKLES, POLLEN PREPARED AS FOODSTUFF, PORK, POTATO FRITTERS, POULTRY NOT LIVE, PROTEIN BEING FOODSTUFFS FOR HUMAN CONSUMPTION, RAISINS, RAPE OIL FOR FOOD, RENNET, VEGETABLE SALADS, SALMON, SARDINES, SAUERKRAUT, SAUSAGES, SAUSAGES IN BATTER, SESAME OIL, SILKWORM CHRYSALIS FOR HUMAN CONSUMPTION, SNAIL EGGS FOR CONSUMPTION, PREPARATIONS FOR MAKING SOUP, VEGETABLE SOUP PREPARATIONS, PRESERVED SOYA BEANS FOR FOOD, SOYA MILK, SUET FOR FOOD, SUNFLOWER OIL FOR FOOD, TAHINI, TOFU, TOMATO JUICE FOR COOKING, TOMATO PUREE, TRIPE, PRESERVED TRUFFLES, COOKED VEGETABLES, DRIED VEGETABLES, PRESERVED VEGETABLES, TINNED VEGETABLES, WEED EXTRACTS FOR FOOD, WHEY, EGG WHITES, YOGURT, EGG YOLKS (U.S. CL. 46).

EMILY CHUO, EXAMINING ATTORNEY

SN 85-302,328. GASTROCEUTICALS, LLC, BEVERLY HILLS, CA. FILED 4-22-2011.

O.F.F.

THE MARK CONSISTS OF STANDARD CHARACTERS WITHOUT CLAIM TO ANY PARTICULAR FONT, STYLE, SIZE, OR COLOR.

FOR ORGANIC, NATURAL AND/OR PROCESSED FOODS AND BEVERAGES, NAMELY, FATS, OILS, DAIRY, NAMELY, MILK, YOGURT AND CHEESE, MEAT, FISH, POULTRY, CANNED, DRIED, COOKED AND/OR FROZEN VEGETABLES, CANNED, DRIED, COOKED AND/OR FROZEN FRUIT, PROCESSED, PREPARED, AND/OR SHELLED NUTS, JAMS, JELLIES (U.S. CL. 46).

KEVIN DINALLO, EXAMINING ATTORNEY

CLASS 29—(Continued).

SN 85-302,375. GASTROCEUTICALS, LLC, BEVERY HILLS, CA. FILED 4-22-2011.



NO CLAIM IS MADE TO THE EXCLUSIVE RIGHT TO USE "FOOD", APART FROM THE MARK AS SHOWN.

THE MARK CONSISTS OF A STICK MAN WITH HIS HANDS RAISED HOLDING THE WORDS "OBESITY FREE FOOD".

FOR ORGANIC, NATURAL AND/OR PROCESSED FOODS AND BEVERAGES, NAMELY, FATS, OILS, DAIRY, NAMELY, MILK, YOGURT AND CHEESE, MEAT, FISH, POULTRY, CANNED, DRIED, COOKED AND/OR FROZEN VEGETABLES, CANNED, DRIED, COOKED AND/OR FROZEN FRUIT, PROCESSED, PREPARED, AND/OR SHELLED NUTS, JAMS, JELLIES (U.S. CL. 46).

KEVIN DINALLO, EXAMINING ATTORNEY

CLASS 29—(Continued).

SN 85-308,844. TAYLOR FRESH FOODS, INC., SALINAS, CA. FILED 4-29-2011.



THE COLOR(S) ORANGE AND BROWN IS/ARE CLAIMED AS A FEATURE OF THE MARK.

THE MARK CONSISTS OF THE WORD "CITIZEN" ABOVE THE WORD "CHEF", BOTH IN LARGE BROWN LETTERING, WITH THE DESIGN OF AN ORANGE COLORED CARROT LOCATED IN BETWEEN THE "I" AND THE "E" IN "CITIZEN", AND THE WORDING "SCRATCH MADE SIMPLE" IN SMALL BROWN LETTERING TO LEFT OF THE WORD "CHEF".

FOR PACKAGED MEAL KITS CONSISTING PRIMARILY OF CUT AND SLICED VEGETABLES AND FRUITS, AND ALSO INCLUDING SAUCES, HERBS, SPICES, SEEDS, NUTS AND GRAINS, NAMELY, RICE, COUS-COUS, QUINOA, BULGUR, AND/OR PASTA, READY FOR COOKING AND ASSEMBLY AS A MEAL (U.S. CL. 46).

RUDY R. SINGLETON, EXAMINING ATTORNEY

SN 85-308,547. NEUROLIFE ADVANTAGE, INC., LOS ANGELES, CA. FILED 4-29-2011.

NEUROLIFE PROTEIN BAR

THE MARK CONSISTS OF STANDARD CHARACTERS WITHOUT CLAIM TO ANY PARTICULAR FONT, STYLE, SIZE, OR COLOR.

NO CLAIM IS MADE TO THE EXCLUSIVE RIGHT TO USE "PROTEIN BAR", APART FROM THE MARK AS SHOWN.

FOR PROTEIN BASED, NUTRIENT-DENSE SNACK BARS (U.S. CL. 46).

KYLE PEETE, EXAMINING ATTORNEY

SN 85-317,598. JK FARMS, LLC, CHAPPELL HILL, TX. FILED 5-10-2011.

JK Smokehouse

THE MARK CONSISTS OF STANDARD CHARACTERS WITHOUT CLAIM TO ANY PARTICULAR FONT, STYLE, SIZE, OR COLOR.

NO CLAIM IS MADE TO THE EXCLUSIVE RIGHT TO USE "SMOKEHOUSE", APART FROM THE MARK AS SHOWN.

FOR MEAT (U.S. CL. 46).

FIRST USE 4-1-2011; IN COMMERCE 4-1-2011.

SUZANNE BLANE, EXAMINING ATTORNEY

CLASS 29—(Continued).

SN 85-358,929. BLEATING HEART CHEESE LLC, DBA BLEATING HEART, SEBASTOPOL, CA. FILED 6-29-2011.



THE MARK CONSISTS OF A CIRCLE CONTAINING A HEART WITH THE STYLIZED WORDING "BLEATING HEART" DISPLAYED AS AN ARC ACROSS THE TOP OF THE HEART.

FOR CHEESE, NAMELY, CHEESES MADE FROM THE MILK OF SHEEP, GOATS, AND COWS; MILK PRODUCTS EXCLUDING ICE CREAM, ICE MILK AND FROZEN YOGURT; MOLD-RIPENED CHEESE; MOULD-RIPENED CHEESE; SHEEP CHEESE (U.S. CL. 46).

FIRST USE 6-1-2009; IN COMMERCE 6-1-2009.
YAT SYE, LEE, EXAMINING ATTORNEY

CLASS 29—(Continued).

SN 85-362,146. THE DANNON COMPANY, INC., WHITE PLAINS, NY. FILED 7-1-2011.



NO CLAIM IS MADE TO THE EXCLUSIVE RIGHT TO USE "FRENCH YOGURT" AND "FRUITY", APART FROM THE MARK AS SHOWN.

THE COLOR(S) BLUE, RED, PINK, WHITE, GREEN AND YELLOW IS/ARE CLAIMED AS A FEATURE OF THE MARK.

THE MARK CONSISTS OF THE WORDING "FRENCH YOGURT SILKY & FRUITY" IN BLUE FONT, ALL OUTLINED IN WHITE, APPEARING OVER AN IMAGE OF A RED, PINK AND WHITE CHECKERED TABLE CLOTH WITH A BACKGROUND OF GREEN GRASS, ALL APPEARING TO THE RIGHT OF AN OBLIQUE LINE; THE BACKGROUND COLOR BETWEEN THE GRASS AND THE OBLIQUE LINE IS YELLOW. THE ENTIRE MARK IS ON A WHITE BACKGROUND.

FOR YOGURT (U.S. CL. 46).
NAKIA HENRY, EXAMINING ATTORNEY

SN 85-380,521. SEA LION INTERNATIONAL, MARGATE, FL. FILED 7-25-2011.

SN 85-362,132. THE DANNON COMPANY, INC., WHITE PLAINS, NY. FILED 7-1-2011.



NO CLAIM IS MADE TO THE EXCLUSIVE RIGHT TO USE "GREEK YOGURT THICK & CREAMY", APART FROM THE MARK AS SHOWN.

THE MARK CONSISTS OF THE WORDING "GREEK YOGURT THICK & CREAMY" IN STYLIZED FONT APPEARING OVER AN IMAGE OF A COLUMN, ALL OF WHICH APPEAR TO THE RIGHT OF AN OBLIQUE LINE.

FOR YOGURT (U.S. CL. 46).
NAKIA HENRY, EXAMINING ATTORNEY

SEA LION

THE MARK CONSISTS OF STANDARD CHARACTERS WITHOUT CLAIM TO ANY PARTICULAR FONT, STYLE, SIZE, OR COLOR.

FOR ARTIFICIAL FISH ROES; CANNED FISH; CHOW MEIN; FISH; FISH CAKES; FISH FILLETS; FROZEN APPETIZERS CONSISTING PRIMARILY OF CHICKEN OR SEAFOOD; FROZEN PRE-PACKAGED ENTREES CONSISTING PRIMARILY OF SEAFOOD; PROCESSED FISH; PROCESSED SEAFOOD, NAMELY, FISH; SEAFOOD; SEAFOOD, NAMELY, SHRIMP; SHELLFISH; SHRIMP; SHRIMPS, NOT LIVE; SHRIMPS, PRAWNS AND LOBSTERS; TUNA FISH (U.S. CL. 46).

FIRST USE 10-12-2004; IN COMMERCE 10-12-2004.
STEPHANIE ALI, EXAMINING ATTORNEY

CLASS 29—(Continued).

SN 85-393,691. CHO LON MOI CORPORATION, SEATTLE, WA. FILED 8-9-2011.

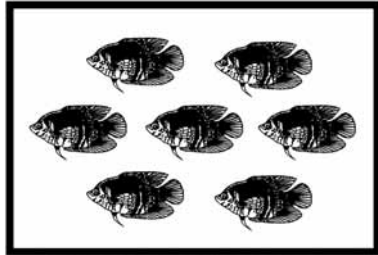

GOURAMY FISH BRAND

OWNER OF U.S. REG. NO. 3,629,007.
 NO CLAIM IS MADE TO THE EXCLUSIVE RIGHT TO USE "FISH BRAND", APART FROM THE MARK AS SHOWN.
 THE MARK CONSISTS OF THE DESIGN OF TWO GOURAMI FISH OVER THE DESIGN OF THREE GOURAMI FISH ALL WITHIN A RECTANGLE BORDER APPEARING OVER THE STYLIZED WORDING "GOURAMY FISH BRAND".
 THE WORDING "GOURAMY" HAS NO MEANING IN A FOREIGN LANGUAGE.
 FOR CANNED BAMBOO SHOOTS; PICKLED VEGETABLES; CANNED FRUIT; FROZEN FRUIT; CANNED VEGETABLES; FISH; MEAT; MEAT BALLS; SAUSAGE; BROTH; DRIED BEANS (U.S. CL. 46).
 FIRST USE 10-0-2007; IN COMMERCE 10-0-2007.
 AMY C. KEAN, EXAMINING ATTORNEY

CLASS 29—(Continued).

SN 85-409,545. CRAVE BROTHERS FARMSTEAD CHEESE, LLC, WATERLOO, WI. FILED 8-29-2011.



NO CLAIM IS MADE TO THE EXCLUSIVE RIGHT TO USE "PRODUCED WITH RENEWABLE ENERGY", APART FROM THE MARK AS SHOWN.
 THE MARK CONSISTS OF A SMALLER CIRCLE WITHIN A LARGER CIRCLE AND A COW POSITIONED WITHIN THE CENTER; THE WORDS "PRODUCED WITH RENEWABLE ENERGY" IS PLACED WITHIN THE OUTSIDE RING. FOR CHEESE (U.S. CL. 46).
 JOHN DALIER, EXAMINING ATTORNEY

SN 85-414,264. GLOBAL SMOKED FOODS LIMITED FOUNDATION, CHARLESTOWN, ST. KITTS-NEVIS, FILED 9-2-2011.

SN 85-409,115. CONOPCO, INC., ENGLEWOOD CLIFFS, NJ. FILED 8-28-2011.

IMPERIAL

THE MARK CONSISTS OF STANDARD CHARACTERS WITHOUT CLAIM TO ANY PARTICULAR FONT, STYLE, SIZE, OR COLOR.
 OWNER OF U.S. REG. NOS. 743,864 AND 2,658,531. FOR VEGETABLE OIL SPREAD (U.S. CL. 46).
 FIRST USE 10-31-1987; IN COMMERCE 10-31-1987.
 CAROLINE WOOD, EXAMINING ATTORNEY



THE MARK CONSISTS OF A DESIGN OF A LOG CABIN. FOR SMOKED FISH, NAMELY, SALMON (U.S. CL. 46).
 FIRST USE 9-11-2003; IN COMMERCE 9-11-2003.
 MARY CRAWFORD, EXAMINING ATTORNEY

CLASS 29—(Continued).

SN 85-414,410. GLOBAL SMOKED FOODS LIMITED FOUNDATION, CHARLESTOWN, ST.KITTS-NEVIS, FILED 9-2-2011.



THE MARK CONSISTS OF THE IMAGE OF A LEAPING FISH SUPERIMPOSED ON TOP OF A FAN-SHAPED GEOMETRIC SHAPE DEPICTING A VIEW OF LAKE, HILLS, AND CLOUDS.

FOR SMOKED FISH, NAMELY, SALMON (U.S. CL. 46).

FIRST USE 9-11-2003; IN COMMERCE 9-11-2003, MARY CRAWFORD, EXAMINING ATTORNEY

CLASS 29—(Continued).

SN 85-427,089. WHITEWAVE SERVICES, INC., DALLAS, TX. FILED 9-20-2011.



OWNER OF U.S. REG. NO. 4,035,744.

NO CLAIM IS MADE TO THE EXCLUSIVE RIGHT TO USE "PURE" AND "FRESH TASTE GUARANTEE", APART FROM THE MARK AS SHOWN.

THE MARK CONSISTS OF A HALO/CROWN DESIGN, TOGETHER WITH THE WORDS "SIMPLY PURE FRESH TASTE GUARANTEE". THE DESIGN ELEMENTS AND WORDING ARE ENCASED IN AN OBLONG SHAPE THAT HAS A CURVED TOP AND BOTTOM.

FOR DAIRY PRODUCTS EXCLUDING ICE CREAM, ICE MILK AND FROZEN YOGURT (U.S. CL. 46).

FIRST USE 7-15-2011; IN COMMERCE 7-15-2011, CHRISTINA SOBRAL, EXAMINING ATTORNEY

SN 85-424,807. RARE HOSPITALITY MANAGEMENT, INC., ORLANDO, FL. FILED 9-16-2011.

T-BONE TOWER

THE MARK CONSISTS OF STANDARD CHARACTERS WITHOUT CLAIM TO ANY PARTICULAR FONT, STYLE, SIZE, OR COLOR.

NO CLAIM IS MADE TO THE EXCLUSIVE RIGHT TO USE "T-BONE", APART FROM THE MARK AS SHOWN.

FOR PREPARED ENTREE CONSISTING PRIMARILY OF STEAK AND ONION RINGS (U.S. CL. 46).

RUSS HERMAN, EXAMINING ATTORNEY

SN 85-430,821. ASHOURIAN, JAMSHID, SANTA MONICA, CA. FILED 9-23-2011.

FREE FRIES

THE MARK CONSISTS OF STANDARD CHARACTERS WITHOUT CLAIM TO ANY PARTICULAR FONT, STYLE, SIZE, OR COLOR.

OWNER OF U.S. REG. NO. 3,531,366.

NO CLAIM IS MADE TO THE EXCLUSIVE RIGHT TO USE "FRIES", APART FROM THE MARK AS SHOWN.

FOR POTATO, VEGETABLE, OR FRUIT BASED SNACK FOODS (U.S. CL. 46).

PAUL MORENO, EXAMINING ATTORNEY

SN 85-426,805. WHITEWAVE SERVICES, INC., DALLAS, TX. FILED 9-20-2011.



OWNER OF U.S. REG. NO. 4,035,744.

NO CLAIM IS MADE TO THE EXCLUSIVE RIGHT TO USE "PURE", APART FROM THE MARK AS SHOWN.

THE MARK CONSISTS OF THE WORDS "SIMPLY PURE" WITH A HALO/CROWN DESIGN DIRECTLY UNDER THE WORDS "SIMPLY PURE".

FOR DAIRY PRODUCTS EXCLUDING ICE CREAM, ICE MILK AND FROZEN YOGURT (U.S. CL. 46).

FIRST USE 7-15-2011; IN COMMERCE 7-15-2011, CHRISTINA SOBRAL, EXAMINING ATTORNEY

SN 85-434,244. FRESH & DIRECT INC., NEW BRAUNFELS, TX. FILED 9-28-2011.

TROPICS BEST

THE MARK CONSISTS OF STANDARD CHARACTERS WITHOUT CLAIM TO ANY PARTICULAR FONT, STYLE, SIZE, OR COLOR.

NO CLAIM IS MADE TO THE EXCLUSIVE RIGHT TO USE "BEST", APART FROM THE MARK AS SHOWN.

FOR COCONUT OIL; DESICCATED COCONUT (U.S. CL. 46).

FIRST USE 8-18-2004; IN COMMERCE 8-20-2004, BRIDGETT SMITH, EXAMINING ATTORNEY

CLASS 29—(Continued).

SN 85-434,530. ZOE'S MEATS, DBA DAPHNE'S CREAMERY, PETALUMA, CA. FILED 9-28-2011.



NO CLAIM IS MADE TO THE EXCLUSIVE RIGHT TO USE "CREAMERY", APART FROM THE MARK AS SHOWN.

THE COLOR(S) BROWN, BLUE, WHITE, GREEN IS/ARE CLAIMED AS A FEATURE OF THE MARK.

THE MARK CONSISTS OF THE WORD "DAPHNE'S" IN BLUE ABOVE THE WORD "CREAMERY" IN GREEN. BLUE FLOWERS, BROWN AND WHITE BACKGROUND.

FOR BUTTER; CHEESE (U.S. CL. 46).
MARK SPARACINO, EXAMINING ATTORNEY

SN 85-434,579. ZOE'S MEATS, DBA DAPHNE'S CREAMERY, PETALUMA, CA. FILED 9-28-2011.



THE COLOR(S) LIGHT PINK, DARK PINK, BROWN IS/ARE CLAIMED AS A FEATURE OF THE MARK.

THE MARK CONSISTS OF THE LETTERS "B U T" IN DARK PINK, THE LETTERS "T E R" IN LIGHT PINK, THE WORD "FAT" IN BROWN, THE WORD "IS" IN DARK PINK, THE LETTERS "B E A U" IN LIGHT PINK, THE LETTERS "T I F U L" IN BROWN.

FOR BUTTER; CHEESE (U.S. CL. 46).
MARK SPARACINO, EXAMINING ATTORNEY

CLASS 29—(Continued).

SN 85-434,961. LACOMBE, BRIAN, SIERRA MADRE, CA. FILED 9-29-2011.



NO CLAIM IS MADE TO THE EXCLUSIVE RIGHT TO USE "BEEF JERKY", APART FROM THE MARK AS SHOWN.

THE MARK CONSISTS OF A CIRCLE WITH THE STYLIZED TEXT "RACER'S EDGE" ARCHING INSIDE THE TOP OF THE CIRCLE WITH THE STYLIZED TEXT "BEEF JERKY" ARCHING INSIDE THE BOTTOM OF THE CIRCLE. UNDER "RACER'S EDGE" IS THE STYLIZED TEXT "GUARANTEED TO" AND ABOVE "BEEF JERKY" IS THE STYLIZED TEXT "SMOKE YOUR TIRES". IN THE CENTER OF THE CIRCLE ARE TWO CHECKERED FLAGS CROSSED IN THE MIDDLE.

FOR BEEF JERKY (U.S. CL. 46).
FIRST USE 6-1-2004; IN COMMERCE 6-1-2004.
KIMBERLY FRYE, EXAMINING ATTORNEY

SN 85-435,521. TRITENT INT'L AGRICULTURE INC., CHICAGO, IL. FILED 9-29-2011.

UNION MILK

THE MARK CONSISTS OF STANDARD CHARACTERS WITHOUT CLAIM TO ANY PARTICULAR FONT, STYLE, SIZE, OR COLOR.

NO CLAIM IS MADE TO THE EXCLUSIVE RIGHT TO USE "MILK", APART FROM THE MARK AS SHOWN.

FOR DAIRY PRODUCTS EXCLUDING ICE CREAM, ICE MILK AND FROZEN YOGURT; MILK; POWDERED MILK (U.S. CL. 46).

LIEF MARTIN, EXAMINING ATTORNEY

CLASS 29—(Continued).

SN 85-441,283. L.A. LUCKY IMPORT & EXPORT INC., BELL, CA. FILED 10-6-2011.

Lucky Crown Brand

THE MARK CONSISTS OF STANDARD CHARACTERS WITHOUT CLAIM TO ANY PARTICULAR FONT, STYLE, SIZE, OR COLOR.

NO CLAIM IS MADE TO THE EXCLUSIVE RIGHT TO USE "BRAND", APART FROM THE MARK AS SHOWN.

FOR CANNED FISH; DRIED VEGETABLES; DUCK EGGS; FERMENTED BAMBOO SHOOTS BOILED AND PRESERVED IN SALT (MENMA); FISH; PROCESSED MUSHROOMS (U.S. CL. 46).

FIRST USE 9-25-2011; IN COMMERCE 9-25-2011.
ALEX KEAM, EXAMINING ATTORNEY

SN 85-442,723. L.A. LUCKY IMPORT & EXPORT INC., BELL, CA. FILED 10-7-2011.



NO CLAIM IS MADE TO THE EXCLUSIVE RIGHT TO USE "L.A." AND "BRAND", APART FROM THE MARK AS SHOWN.

THE COLOR(S) RED, GREY, GREEN, BROWN, PEACH, YELLOW, BLACK, AND WHITE IS/ARE CLAIMED AS A FEATURE OF THE MARK.

THE MARK CONSISTS OF A BACKGROUND DESIGN IN THE COLORS GREY AND WHITE HAVING A BORDER IN THE COLOR OF RED. WITHIN THE DESIGN IS THE WORDING "L.A." IN STYLIZED FONT IN THE COLOR OF RED AND HAS A DARK GREY SHADOW. DIRECTLY TO THE RIGHT OF THE WORDING "L.A." IS A DESIGN OF A PERSON WEARING A GREEN SHIRT WITH BLACK BUTTONS AND POCKET. THE PERSON IS HOLDING A GRUB HOE, IN THE COLOR OF BROWN AND GREY THAT HAS A SHADOW OF DARK GREY, IN HIS RIGHT HAND. HE IS ALSO WEARING A BROWN HAT AND GREY PANTS WITH A WHITE BELT. HIS SKIN IS IN THE COLOR OF PEACH AND HIS FACIAL FEATURES ARE IN THE COLOR OF BROWN. DIRECTLY ABOVE THE PERSON TO THE UPPER RIGHT IS A SUN IN THE COLOR OF YELLOW. DIRECTLY TO THE RIGHT OF THE PERSON IS THE WORDING "LUCKY" IN STYLIZED FONT AND IN THE COLOR OF RED AND HAS A DARK GREY SHADOW. DIRECTLY BELOW THE WORDING "LUCKY" IS THE WORDING "BRAND" IN STYLIZED FONT AND IN THE COLOR OF RED THAT IS POSITIONED WITHIN THE SHAPE'S BORDER.

FOR BROTH; CANNED BEANS; CANNED FISH; CANNED FRUITS; CANNED VEGETABLES; FERMENTED BAMBOO SHOOTS BOILED AND PRESERVED IN SALT (MENMA); PRESERVED VEGETABLES; PROCESSED MUSHROOMS; SOUP PASTES (U.S. CL. 46).

FIRST USE 2-10-2006; IN COMMERCE 2-11-2006.
ALEX KEAM, EXAMINING ATTORNEY

CLASS 29—(Continued).

SN 85-443,399. MEMORY LANE DAIRY, LLC, SPRINGFIELD, MO. FILED 10-10-2011.

MEMORY LANE DAIRY

THE MARK CONSISTS OF STANDARD CHARACTERS WITHOUT CLAIM TO ANY PARTICULAR FONT, STYLE, SIZE, OR COLOR.

NO CLAIM IS MADE TO THE EXCLUSIVE RIGHT TO USE "DAIRY", APART FROM THE MARK AS SHOWN.

FOR MILK, FLAVORED MILK (U.S. CL. 46).
FIRST USE 3-21-2001; IN COMMERCE 3-21-2001.
MATTHEW KLINE, EXAMINING ATTORNEY

SN 85-443,705. SUNCREST FARMS COUNTRY HAMS, INC., WILKESBORO, NC. FILED 10-10-2011.

SUNCREST FARMS

THE MARK CONSISTS OF STANDARD CHARACTERS WITHOUT CLAIM TO ANY PARTICULAR FONT, STYLE, SIZE, OR COLOR.

NO CLAIM IS MADE TO THE EXCLUSIVE RIGHT TO USE "FARMS", APART FROM THE MARK AS SHOWN.

FOR HAM; PORK RINDS (U.S. CL. 46).
FIRST USE 0-0-1995; IN COMMERCE 0-0-1995.
NELSON SNYDER, EXAMINING ATTORNEY

SN 85-444,204. LAWSON, LINCOLN WENTWORTH, DBA LINCOLN THE GREAT, MARINA DEL REY, CA. FILED 10-11-2011.

MINISTRY MILK

THE MARK CONSISTS OF STANDARD CHARACTERS WITHOUT CLAIM TO ANY PARTICULAR FONT, STYLE, SIZE, OR COLOR.

NO CLAIM IS MADE TO THE EXCLUSIVE RIGHT TO USE "MILK", APART FROM THE MARK AS SHOWN.

FOR MILK (U.S. CL. 46).
YAT SYE, LEE, EXAMINING ATTORNEY

CLASS 29—(Continued).

SN 85-444,331. SIYUAN FOOD USA CORP., FORT LEE, NJ. FILED 10-11-2011.

Blue Bay Seafood

THE MARK CONSISTS OF STANDARD CHARACTERS WITHOUT CLAIM TO ANY PARTICULAR FONT, STYLE, SIZE, OR COLOR.

NO CLAIM IS MADE TO THE EXCLUSIVE RIGHT TO USE "SEAFOOD", APART FROM THE MARK AS SHOWN. FOR SEAFOOD, NAMELY, FROZEN TILAPIA AND GOLDEN POMPANO (U.S. CL. 46).

JORDAN BAKER, EXAMINING ATTORNEY

CLASS 29—(Continued).

SN 85-446,384. THE MEATLOAF BAKERY LLC, CHICAGO, IL. FILED 10-13-2011.

YENTL LENTL LOAF

THE MARK CONSISTS OF STANDARD CHARACTERS WITHOUT CLAIM TO ANY PARTICULAR FONT, STYLE, SIZE, OR COLOR.

NO CLAIM IS MADE TO THE EXCLUSIVE RIGHT TO USE "LENTIL LOAF", APART FROM THE MARK AS SHOWN.

FOR PREPARED READY TO EAT ENTREES CONSISTING PRIMARILY OF LEGUMES, RICE AND VEGETABLES (U.S. CL. 46).

FIRST USE 12-10-2008; IN COMMERCE 12-10-2008. CHARLES L. JENKINS, EXAMINING ATTORNEY

SN 85-445,678. FPL FOODS LLC, AUGUSTA, GA. FILED 10-12-2011.

SOUTHERN RIVER FARMS

THE MARK CONSISTS OF STANDARD CHARACTERS WITHOUT CLAIM TO ANY PARTICULAR FONT, STYLE, SIZE, OR COLOR.

NO CLAIM IS MADE TO THE EXCLUSIVE RIGHT TO USE "FARMS", APART FROM THE MARK AS SHOWN. FOR MEAT, PORK AND POULTRY (U.S. CL. 46).

RONALD MCMORROW, EXAMINING ATTORNEY

SN 85-446,504. THE MEATLOAF BAKERY LLC, CHICAGO, IL. FILED 10-13-2011.

A Wing And A Prayer Loaf

THE MARK CONSISTS OF STANDARD CHARACTERS WITHOUT CLAIM TO ANY PARTICULAR FONT, STYLE, SIZE, OR COLOR.

NO CLAIM IS MADE TO THE EXCLUSIVE RIGHT TO USE "LOAF", APART FROM THE MARK AS SHOWN.

FOR PREPARED READY-TO-EAT ENTREES CONSISTING PRIMARILY OF MEAT (U.S. CL. 46).

FIRST USE 12-10-2008; IN COMMERCE 12-10-2008. CHARLES L. JENKINS, EXAMINING ATTORNEY

SN 85-446,102. THE MRS. FIELDS' BRAND, INC., SALT LAKE CITY, UT. FILED 10-12-2011.

PRIMAL ENERGY

THE MARK CONSISTS OF STANDARD CHARACTERS WITHOUT CLAIM TO ANY PARTICULAR FONT, STYLE, SIZE, OR COLOR.

FOR TRAIL MIX CONSISTING PRIMARILY OF PROCESSED NUTS, SEEDS, DRIED FRUIT AND ALSO INCLUDING CHOCOLATE (U.S. CL. 46).

HANNO RITTNER, EXAMINING ATTORNEY

SN 85-446,541. THE MEATLOAF BAKERY LLC, CHICAGO, IL. FILED 10-13-2011.

No Buns About It Burger Loaf

THE MARK CONSISTS OF STANDARD CHARACTERS WITHOUT CLAIM TO ANY PARTICULAR FONT, STYLE, SIZE, OR COLOR.

NO CLAIM IS MADE TO THE EXCLUSIVE RIGHT TO USE "BURGER LOAF", APART FROM THE MARK AS SHOWN.

FOR PREPARED READY-TO-EAT ENTREES CONSISTING PRIMARILY OF MEAT (U.S. CL. 46).

FIRST USE 12-10-2008; IN COMMERCE 12-10-2008. CHARLES L. JENKINS, EXAMINING ATTORNEY

CLASS 29—(Continued).

SN 85-446,583. SIKORSKI SAUSAGES CO. LTD., LONDON, ONTARIO, CANADA, FILED 10-13-2011.

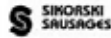

NO CLAIM IS MADE TO THE EXCLUSIVE RIGHT TO USE "SAUSAGES", APART FROM THE MARK AS SHOWN. THE MARK CONSISTS OF THE RENDITION OF TWO SAUSAGES FORMING THE LETTER "S" AND THE WORDS "SIKORSKI SAUSAGES" TO THE RIGHT.

FOR MEATS, NAMELY, SAUSAGES, BEEF TARTAR, PEPPERONI, KIELBASA, WIENERS, HAMS, BACON, LIVERWURST, FRANKFURTERS, PORK, PATE, MEAT LOAF; POULTRY, NAMELY, CHICKEN, TURKEY AND GAME (U.S. CL. 46).

MARY CRAWFORD, EXAMINING ATTORNEY

SN 85-446,822. CORTOPASSI PARTNERS, MODESTO, CA. FILED 10-13-2011.

TROMBETTA

THE MARK CONSISTS OF STANDARD CHARACTERS WITHOUT CLAIM TO ANY PARTICULAR FONT, STYLE, SIZE, OR COLOR.

THE ENGLISH TRANSLATION OF THE WORD "TROMBETTA" IN THE MARK IS TOY TROMBONE.

FOR EDIBLE OIL; COOKING OIL; SALAD OIL; OLIVE OIL (U.S. CL. 46).

ANNE E. GUSTASON, EXAMINING ATTORNEY

SN 85-446,830. CORTOPASSI PARTNERS, MODESTO, CA. FILED 10-13-2011.

PINNACLE

THE MARK CONSISTS OF STANDARD CHARACTERS WITHOUT CLAIM TO ANY PARTICULAR FONT, STYLE, SIZE, OR COLOR.

FOR EDIBLE OIL; COOKING OIL; SALAD OIL; OLIVE OIL (U.S. CL. 46).

ANNE E. GUSTASON, EXAMINING ATTORNEY

CLASS 29—(Continued).

SN 85-446,857. LINK SNACKS, INC., MINONG, WI. FILED 10-13-2011.

RUN WITH THE BULL

THE MARK CONSISTS OF STANDARD CHARACTERS WITHOUT CLAIM TO ANY PARTICULAR FONT, STYLE, SIZE, OR COLOR.

FOR MEAT SNACKS (U.S. CL. 46).

KIMBERLY PERRY, EXAMINING ATTORNEY

SN 85-446,860. LINK SNACKS, INC., MINONG, WI. FILED 10-13-2011.



OWNER OF U.S. REG. NOS. 3,664,923 AND 3,723,467.

THE MARK CONSISTS OF A STEER WITH HORNS, TAIL AND A STAR EYE. BENEATH THE STEER'S HEAD IS THE WORDING "RUN WITH THE BULL".

FOR MEAT SNACKS (U.S. CL. 46).

KIMBERLY PERRY, EXAMINING ATTORNEY

SN 85-447,073. FLAVOR-PIC TOMATO CO., INC., BIRMINGHAM, AL. FILED 10-13-2011.



THE MARK CONSISTS OF AN ANTHROPOMORPHIZED TOMATO WEARING A CAP AND HOLDING A SLINGSHOT WITH A TOMATO IN IT.

FOR PACKAGED FRESH FRUITS AND VEGETABLES; PACKAGED FRESH FRUIT AND VEGETABLE SNACKS (U.S. CL. 46).

CHRISTINE MARTIN, EXAMINING ATTORNEY

CLASS 29—(Continued).

SN 85-447,184. DESCORP MANAGEMENT LLC, BATON ROUGE, LA. FILED 10-13-2011.

BOUDIN BOY

THE MARK CONSISTS OF STANDARD CHARACTERS WITHOUT CLAIM TO ANY PARTICULAR FONT, STYLE, SIZE, OR COLOR.

NO CLAIM IS MADE TO THE EXCLUSIVE RIGHT TO USE "BOUDIN", APART FROM THE MARK AS SHOWN.

FOR SAUSAGES (U.S. CL. 46).
KRISTIN DAHLING, EXAMINING ATTORNEY

SN 85-449,564. DILUIGI'S, INC., DANVERS, MA. FILED 10-18-2011.

DILUIGI

THE MARK CONSISTS OF STANDARD CHARACTERS WITHOUT CLAIM TO ANY PARTICULAR FONT, STYLE, SIZE, OR COLOR.

SEC. 2(F).

FOR RAW, FROZEN AND COOKED MEATS, NAMELY, CHICKEN, PORK, TURKEY, VEAL AND BEEF; PREPARED ENTREES COMPRISED PRIMARILY OF BEEF, PORK, TURKEY AND/OR CHICKEN; SAUSAGES OF PORK, TURKEY AND/OR CHICKEN; BEEF, CHICKEN AND TURKEY PATTIES; MARINATED BEEF, CHICKEN, TURKEY AND PORK (U.S. CL. 46).

FIRST USE 0-0-1979; IN COMMERCE 0-0-1979.
DEBORAH LOBO, EXAMINING ATTORNEY

SN 85-449,702. OSCAR TORRES HERNANDEZ, NUEVO LEÓN, MEXICO, FILED 10-18-2011.



THE MARK CONSISTS OF THREE SMILING CACTI WITH ARMS AND WEARING HATS AND VESTS. FOR SPICY, SWEET AND DRIED CACTUS FOR FOOD PURPOSES (U.S. CL. 46).

FIRST USE 9-1-2011; IN COMMERCE 9-1-2011.
INGA ERVIN, EXAMINING ATTORNEY

CLASS 29—(Continued).

SN 85-453,397. REALAGE, INC., SAN DIEGO, CA. FILED 10-21-2011.

REALAGE

THE MARK CONSISTS OF STANDARD CHARACTERS WITHOUT CLAIM TO ANY PARTICULAR FONT, STYLE, SIZE, OR COLOR.

OWNER OF U.S. REG. NOS. 2,155,113, 3,216,403 AND OTHERS.

FOR FROZEN, PREPARED, AND PACKAGED MEALS CONSISTING PRIMARILY OF MEAT, FISH, POULTRY OR VEGETABLES; FROZEN, PREPARED, AND PACKAGED VEGETABLE-BASED ENTREES; TEXTURED VEGETABLE PROTEIN FOR USE AS A MEAT EXTENDER; PRE-CUT VEGETABLE SALAD; VEGGIE BURGER PATTIES; CHEESE SUBSTITUTES; EGG SUBSTITUTE; MEAT SUBSTITUTES; POULTRY SUBSTITUTES; RICE MILK FOR USE AS A MILK SUBSTITUTE; SOY-BASED FOOD BEVERAGE USED AS A MILK SUBSTITUTE; VEGETABLE-BASED MEAT SUBSTITUTES; MILK BEVERAGES WITH HIGH MILK CONTENT; FRUIT CHIPS; POTATO CRISPS AND CHIPS; SOY CHIPS; VEGETABLE CHIPS; PROCESSED FRUIT- AND NUT-BASED FOOD BARS; SOY-BASED FOOD BARS; SOUPS AND PREPARATIONS FOR MAKING SOUPS (U.S. CL. 46).

MARK T. MULLEN, EXAMINING ATTORNEY

SN 85-453,820. THE MRS. FIELDS' BRAND, INC., SALT LAKE CITY, UT. FILED 10-22-2011.

PRIMITIVE SNACKS

THE MARK CONSISTS OF STANDARD CHARACTERS WITHOUT CLAIM TO ANY PARTICULAR FONT, STYLE, SIZE, OR COLOR.

NO CLAIM IS MADE TO THE EXCLUSIVE RIGHT TO USE "SNACKS", APART FROM THE MARK AS SHOWN.

FOR BEEF JERKY; COCONUT POWDER; COCONUT-BASED BEVERAGE USED AS A MILK SUBSTITUTE; JERKY; MEAT-BASED SNACK FOODS; PROTEIN BASED, NUTRIENT-DENSE SNACK BARS; SNACK MIX CONSISTING OF PRIMARILY OF PROCESSED NUTS, SEEDS, DRIED FRUIT AND ALSO INCLUDING CHOCOLATE; TRAIL MIX CONSISTING PRIMARILY OF PROCESSED NUTS, SEEDS, DRIED FRUIT AND ALSO INCLUDING CHOCOLATE (U.S. CL. 46).

HANNO RITTNER, EXAMINING ATTORNEY

CLASS 29—(Continued).

SN 85-454,146. GLOBAL SMOKED FOODS LIMITED FOUNDATION, CHARLESTOWN, ST.KITTS-NEVIS, FILED 10-24-2011.

GRANTS

THE MARK CONSISTS OF STANDARD CHARACTERS WITHOUT CLAIM TO ANY PARTICULAR FONT, STYLE, SIZE, OR COLOR.

FOR SMOKED FISH; SALMON (U.S. CL. 46).
FIRST USE 1-1-1997; IN COMMERCE 1-1-1997.
MARY CRAWFORD, EXAMINING ATTORNEY

SN 85-454,401. THE MRS. FIELDS' BRAND, INC., SALT LAKE CITY, UT. FILED 10-24-2011.

PRIMITIVE ENERGY

THE MARK CONSISTS OF STANDARD CHARACTERS WITHOUT CLAIM TO ANY PARTICULAR FONT, STYLE, SIZE, OR COLOR.

NO CLAIM IS MADE TO THE EXCLUSIVE RIGHT TO USE "ENERGY", APART FROM THE MARK AS SHOWN.

FOR BEEF JERKY; COCONUT POWDER; COCONUT-BASED BEVERAGE USED AS A MILK SUBSTITUTE; JERKY; MEAT-BASED SNACK FOODS; PROTEIN BASED, NUTRIENT-DENSE SNACK BARS; SNACK MIX CONSISTING OF PRIMARILY OF PROCESSED NUTS, SEEDS, DRIED FRUIT AND ALSO INCLUDING CHOCOLATE; TRAIL MIX CONSISTING PRIMARILY OF PROCESSED NUTS, SEEDS, DRIED FRUIT AND ALSO INCLUDING CHOCOLATE (U.S. CL. 46).

HANNO RITTNER, EXAMINING ATTORNEY

SN 85-454,858. BROWN, WENDELL, CYPRESS, TX. FILED 10-24-2011.

Wendell's Special Chili

THE MARK CONSISTS OF STANDARD CHARACTERS WITHOUT CLAIM TO ANY PARTICULAR FONT, STYLE, SIZE, OR COLOR.

NO CLAIM IS MADE TO THE EXCLUSIVE RIGHT TO USE "SPECIAL CHILI", APART FROM THE MARK AS SHOWN.

FOR CHILI (U.S. CL. 46).
TASNEEM HUSSAIN, EXAMINING ATTORNEY

CLASS 29—(Continued).

SN 85-455,757. OSCAR TORRES HERNANDEZ, NUEVO LEON, MEXICO, FILED 10-25-2011.

NOPALAZO

THE MARK CONSISTS OF STANDARD CHARACTERS WITHOUT CLAIM TO ANY PARTICULAR FONT, STYLE, SIZE, OR COLOR.

FOR SPICY, SWEET AND DRIED CACTUS FOR FOOD PURPOSES (U.S. CL. 46).

FIRST USE 9-1-2011; IN COMMERCE 9-1-2011.
INGA ERVIN, EXAMINING ATTORNEY

SN 85-462,562. GIOVANNINA JENNIFER BELLINO, SANDS POINT, NY. FILED 11-2-2011.

Goddess Gourmet

THE MARK CONSISTS OF STANDARD CHARACTERS WITHOUT CLAIM TO ANY PARTICULAR FONT, STYLE, SIZE, OR COLOR.

NO CLAIM IS MADE TO THE EXCLUSIVE RIGHT TO USE "GOURMET", APART FROM THE MARK AS SHOWN.

FOR PREPARED FOOD KITS COMPOSED OF MEAT, POULTRY, FISH, SEAFOOD, AND/OR VEGETABLES AND ALSO INCLUDING SAUCES OR SEASONINGS, READY FOR COOKING AND ASSEMBLY AS A MEAL (U.S. CL. 46).

RONALD MCMORROW, EXAMINING ATTORNEY

SN 85-471,733. AMERICAN SEAFOODS GROUP LLC, SEATTLE, WA. FILED 11-14-2011.

CATCH THE EXCITEMENT

THE MARK CONSISTS OF STANDARD CHARACTERS WITHOUT CLAIM TO ANY PARTICULAR FONT, STYLE, SIZE, OR COLOR.

FOR SEAFOOD (U.S. CL. 46).
DAVID C. REIHNER, EXAMINING ATTORNEY

CLASS 29—(Continued).

SN 85-471,814. AMERICAN SEAFOODS GROUP LLC, SEATTLE, WA. FILED 11-14-2011.

A STEP AHEAD

THE MARK CONSISTS OF STANDARD CHARACTERS WITHOUT CLAIM TO ANY PARTICULAR FONT, STYLE, SIZE, OR COLOR.
FOR SEAFOOD (U.S. CL. 46).
DAVID C. REIHNER, EXAMINING ATTORNEY

SN 85-477,069. WRIGHT, BRUCE DAVID, SARASOTA, FL. FILED 11-18-2011.

BIO chew

THE MARK CONSISTS OF STANDARD CHARACTERS WITHOUT CLAIM TO ANY PARTICULAR FONT, STYLE, SIZE, OR COLOR.
NO CLAIM IS MADE TO THE EXCLUSIVE RIGHT TO USE "CHEW", APART FROM THE MARK AS SHOWN.
FOR FRUIT-BASED ORGANIC FOOD BARS (U.S. CL. 46).
DEZMONA MIZELLE, EXAMINING ATTORNEY

SN 85-503,315. D'ARTAGNAN TRADEMARKS, LLC, NEWARK, NJ. FILED 12-23-2011.

ROHAN

THE MARK CONSISTS OF STANDARD CHARACTERS WITHOUT CLAIM TO ANY PARTICULAR FONT, STYLE, SIZE, OR COLOR.
FOR POULTRY, NAMELY, DUCK (U.S. CL. 46).
KATHRYN COWARD, EXAMINING ATTORNEY

CLASS 29—(Continued).

SN 85-514,817. AMERICAN SEAFOODS GROUP LLC, SEATTLE, WA. FILED 1-12-2012.

54°N

THE MARK CONSISTS OF THE NUMBER "54" FOLLOWED BY A DEGREE SYMBOL AND THE LETTER "N" WITH A TRIANGLE ABOVE.
FOR CAVIAR AND FISH OIL (U.S. CL. 46).
DAVID C. REIHNER, EXAMINING ATTORNEY

CLASS 30—STAPLE FOODS

SN 76-704,100. MARUKYO SEIKA KABUSHIKI KAISHA, YONAGO-SHI, TOTTORI, JAPAN, FILED 8-11-2010.



OWNER OF U.S. REG. NOS. 3,464,885 AND 3,518,722.
NO CLAIM IS MADE TO THE EXCLUSIVE RIGHT TO USE THE NON-LATIN CHARACTERS THAT TRANSLITERATE TO MEIKA NO TORIAWASE, NIHONCHA NI YOKU, MATHCA MANJU AND SOBA MANJU AND THE DESIGN OF THE MANJU AS IT APPEARS ON THE PLATE, APART FROM THE MARK AS SHOWN.
THE COLOR(S) RED, BLACK, VENETIAN RED, WHITE, SEAL BROWN, CHOCOLATE BROWN, SAP GREEN, ROSEWOOD RED, SANGRIA RED, GREEN, WHEAT, BURGUNDY, MAUVE, RASPBERRY, MAGENTA, OLIVE DRAB, COPPER, OCHRE, ORANGE, CRIMSON AND YELLOW IS/ ARE CLAIMED AS A FEATURE OF THE MARK.
THE MARK CONSISTS OF A STYLIZED DESIGN FEATURING A CIRCLE WITHIN A LOOPING CURVED LINE, ALL IN RED AND THE AREA BETWEEN THE CIRCLE AND LOOPING CURVED LINE BEING WHITE, FOLLOWED BY THE DESIGN OF TWO JAPANESE CHARACTERS IN BLACK, FOLLOWED BY THE WORDING "MARUKYO" IN BLACK, THE WORDING "MARUKYO" IS OVER A RECTANGLE OF VENETIAN RED WHICH FADES RIGHT TO LEFT TO WHITE. BELOW IS THE WORDING "MEISAKU" IN BLACK. BELOW THE WORD "MEISAKU" IS A WHITE CUP WITH SHADING SITTING ON A WOOD GRAIN COASTER OF SEAL BROWN AND CHOCOLATE BROWN IN THE CUP IS A SAP GREEN SUBSTANCE. OVERLAPPING THE COASTER IS A PLATE HAVING A ROSEWOOD RED BORDER AND SHADED SANGRIA RED. ON THE PLATE ARE 6 WHITE PACKAGES, THREE HAVING A RED STRIPE AND THREE HAVING A GREEN STRIPE, AND FEATURING A CIRCLE WITHIN A LOOPING CURVED LINE, ALL IN RED, FOLLOWED BY THE DESIGN OF FIVE JAPANESE CHARACTERS IN BLACK ON THE LEFT SIDE AND JAPANESE LETTERS ON THE RIGHT SIDE. SOME OF THE LETTERING OF THE PACKAGES IS COVERED BY OTHER PACKAGES. OVER THE PACKAGES ARE THREE FLOWER SHAPED BUNS

CLASS 30—(Continued).

COLORED WHEAT, TWO CIRCULAR SHAPED BUNS COLORED WHEAT AND OCHRE, AND TWO TAPERED BUNS COLORED WHEAT ON THE EDGES AND BURGUNDY IN THE CENTERS WITH WHEAT COLORED SPECKS. ON THE RIGHT HAND SIDE IS A HEXAGON, PARTIALLY COVERED BY THE PLATE. THE HEXAGON HAVING AN OUTER BORDER OF MAUVE ON THE TOP AND RASPBERRY ON THE BOTTOM, AN INNER BORDER OF MAGENTA AND AN INNER BORDER OF COPPER. INSIDE THE HEXAGON IS A LARGE OLIVE DRAB CIRCLE AND A SMALLER OLIVE DRAB CIRCLE BELOW THE LARGER CIRCLE. ON THE LARGE CIRCLE ARE TWO LINES OF JAPANESE CHARACTERS. IN THE CENTER OF THE HEXAGON ARE JAPANESE CHARACTERS, THE CENTER OF THE HEXAGON BEING WHITE. ON THE RIGHT INSIDE THE HEXAGON IS A VERTICAL BANNER COLORED CRIMSON AT BOTH ENDS AND FADING TO ORANGE THEN YELLOW AT THE CENTER. ON THE BANNER ARE TWO SETS OF JAPANESE CHARACTERS SEPARATED BY A BULLET POINT.

THE ENGLISH TRANSLATION OF "MEISAKU" IS INSCRIPTION MAKE, "AJI NO" IS OF TASTE, "MEIKA NO TORIAWASE" IS ASSORTMENT OF THE FAMOUS KIND OF PASTRIES, "NIHONCHA NI YOKUUAU" IS WELL MATCHED WITH JAPANESE TEA, "MATHCA MANJU" IS BUN STUFFED WITH THE POWDERED GREEN TEA FLAVORED BEAN JAM, "SOBA MANJU" IS BUN STUFFED WITH THE BUCKWHEAT FLOUR FLAVORED BEAN JAM.

THE TWO NON-LATIN CHARACTERS BEFORE "MARUKYO" TRANSLITERATE INTO "MARUKYO", WHICH IS PART OF APPLICANT'S NAME. THE NON-LATIN CHARACTERS OVER THE OLIVE DRAB CIRCLE OF THE MARK TRANSLITERATE INTO "MEIKA NO TORIAWASE" AND "NIHONCHA NI YOKUUAU", WHICH MEANS ASSORTMENT OF THE FAMOUS KIND OF PASTRIE AND WELL MATCHED WITH JAPANESE TEA IN ENGLISH. THE NON-LATIN CHARACTERS ON THE WHITE BACKGROUND IN THE HEXAGON TRANSLITERATE INTO "AJI NO" AND "MEISAKU", WHICH MEANS OF TASTE AND INSCRIPTION MAKE IN ENGLISH. THE NON-LATIN CHARACTERS ON THE GREEN STRIPED PACKAGES TRANSLITERATE INTO "MATHCA MANJU", WHICH MEANS BUN STUFFED WITH THE POWDERED GREEN TEA FLAVORED BEAN-JAM IN ENGLISH. THE NON-LATIN CHARACTERS ON THE RED STRIPED PACKAGES TRANSLITERATE INTO "SOBA MANJU", WHICH MEANS BUN STUFFED WITH THE BUCKWHEAT FLOUR FLAVORED BEAN-JAM IN ENGLISH.

FOR BUN WITH BEAN-JAM FILLING (MANJU) (U.S. CL. 46).

ALAIN LAPTER, EXAMINING ATTORNEY

SN 77-685,192. BAB, INC., DEERFIELD, IL. FILED 3-6-2009.

CELEBRATION CUPCAKES

THE MARK CONSISTS OF STANDARD CHARACTERS WITHOUT CLAIM TO ANY PARTICULAR FONT, STYLE, SIZE, OR COLOR.

NO CLAIM IS MADE TO THE EXCLUSIVE RIGHT TO USE "CUPCAKES", APART FROM THE MARK AS SHOWN. FOR BAKERY PRODUCTS, NAMELY, CUPCAKES (U.S. CL. 46).

FIRST USE 12-1-2008; IN COMMERCE 1-21-2009.

MARC LEIPZIG, EXAMINING ATTORNEY

CLASS 30—(Continued).

SN 77-729,672. RARE HOSPITALITY MANAGEMENT, INC., ORLANDO, FL. FILED 5-5-2009.

CHOCOLATE STAMPEDE

THE MARK CONSISTS OF STANDARD CHARACTERS WITHOUT CLAIM TO ANY PARTICULAR FONT, STYLE, SIZE, OR COLOR.

NO CLAIM IS MADE TO THE EXCLUSIVE RIGHT TO USE "CHOCOLATE", APART FROM THE MARK AS SHOWN.

FOR FOOD PRODUCTS, NAMELY, A PREPARED DESSERT CONSISTING OF CHOCOLATE CAKE, CHOCOLATE MOUSSE AND FUDGE ICING, FOR CONSUMPTION ON OR OFF PREMISES (U.S. CL. 46).

FIRST USE 2-28-2003; IN COMMERCE 2-28-2003.

MICHAEL ENGEL, EXAMINING ATTORNEY

SN 79-098,169. DAESANG CORPORATION, REPUBLIC OF KOREA, FILED 4-5-2011.

ROSEBUD

PRIORITY DATE OF 11-23-2010 IS CLAIMED. OWNER OF INTERNATIONAL REGISTRATION 1079413 DATED 4-5-2011, EXPIRES 4-5-2021.

FOR COFFEE SUBSTITUTES; COFFEE BEVERAGES WITH MILK; CHOCOLATE-BASED BEVERAGES; COFFEE; COFFEE-BASED BEVERAGES; COCOA; COCOA-BASED BEVERAGES; UNROASTED COFFEE; CHOCOLATE-BASED BEVERAGES WITH MILK; ROASTED COFFEE BEANS; COFFEE BEANS FOR MAKING GROUND COFFEE; TEA-BASED BEVERAGES; COFFEE FLAVORED SYRUP USED IN MAKING FOOD BEVERAGES; BISCUITS; CAKE MIXES; CANDY FOR FOOD; GRAIN-BASED CHIPS; CHOCOLATE; CONFECTIONERY MADE OF SUGAR; COOKIES; DRESSINGS FOR SALAD; FLOUR-MILLED PRODUCTS, NAMELY, BISCUITS; NOODLES; PASTA; FERMENTED SOYBEAN PASTE FOR USE AS A CONDIMENT ('DOYN-JANG'); SAUCES (CONDIMENTS); SOYA SAUCE; SPICES; TEA; VINEGAR; FERMENTED HOT PEPPER PASTE FOR USE AS A CONDIMENT ('GOCHU-JANG'); BREAD; ARTIFICIAL FOOD SEASONINGS; FLOUR FOR FOOD; NATURAL SWEETENERS; SALT FOR FOOD; SUGAR FOR FOOD; CEREAL-BASED PROCESSED PRODUCTS, NAMELY, BREAKFAST CEREAL (U.S. CL. 46).

GENE MACIOL, EXAMINING ATTORNEY

CLASS 30—(Continued).

SN 79-098,687. NONGFU SPRING CO., LTD., CHINA, FILED 6-6-2011.

东方树叶

OWNER OF INTERNATIONAL REGISTRATION 1080826 DATED 6-6-2011, EXPIRES 6-6-2021.

THE ENGLISH TRANSLATION OF THE FOREIGN WORD(S) IN THE MARK IS: IN CHINESE, DONG MEANS THE EAST, FANG MEANS DIRECTIONS, SHU MEANS TREES AND YE MEANS LEAVES, AS A COMBINATION OF CHINESE CHARACTERS OF DONG FANG SHU YE, THIS MARK HAS NO SPECIFIC MEANING IN TRADE GEOGRAPHY.

THE TRANSLITERATION OF THE NON-LATIN CHARACTERS IN THE MARK IS: DONG FANG SHU YE.

FOR COFFEE-BASED BEVERAGES; TEA; TEA-BASED BEVERAGES; CANDIES; DIETETIC SUBSTANCES ADAPTED FOR NON-MEDICAL PURPOSES, NAMELY, PROPOLIS FOR FOOD PURPOSES; CEREAL BASED SNACK FOOD; CEREAL PREPARATIONS, NAMELY, OATMEAL; FLOUR-MILLING PRODUCTS, NAMELY, CORN FLOUR; FARINACEOUS FOODS, NAMELY, FARINACEOUS FOOD PASTES FOR HUMAN CONSUMPTION; ICE CREAM; SEASONINGS; FLAVORING SAUCES; ESSENCES FOR FOODSTUFFS, EXCEPT ETHERIC ESSENCES AND ESSENTIAL OILS, NAMELY, ANISEED AND CHINESE CINNAMON (U.S. CL. 46).
MAYUR VAGHANI, EXAMINING ATTORNEY

SN 79-108,173. TRISELECTA, S.L., SPAIN, FILED 9-5-2011.

SAFRINA

OWNER OF INTERNATIONAL REGISTRATION 1104319 DATED 9-5-2011, EXPIRES 9-5-2021.

FOR SPICES (U.S. CL. 46).
PAUL MORENO, EXAMINING ATTORNEY

SN 85-030,517. RIKA BAKERIES, INC., HIALEAH, FL. FILED 5-5-2010.

RIKA

THE MARK CONSISTS OF STANDARD CHARACTERS WITHOUT CLAIM TO ANY PARTICULAR FONT, STYLE, SIZE, OR COLOR.

FOR CRACKERS AND CRACKER MEAL (U.S. CL. 46).
FIRST USE 2-18-1964; IN COMMERCE 2-18-1964.
REBECCA SMITH, EXAMINING ATTORNEY

CLASS 30—(Continued).

SN 85-063,664. AMES INTERNATIONAL, INC., FIFE, WA. FILED 6-15-2010.



OWNER OF U.S. REG. NOS. 1,602,572, 2,245,300 AND 3,172,310.

THE NAME(S), PORTRAIT(S), AND/OR SIGNATURE(S) SHOWN IN THE MARK IDENTIFIES "EMILY" PAULOSE, WHOSE CONSENT(S) TO REGISTER IS MADE OF RECORD.

THE MARK CONSISTS OF THE LITERAL ELEMENT "EMILY'S" AND A DESIGN ELEMENT CONSISTING OF THE JAPANESE CHARACTER FOR FRIENDSHIP THAT APPEAR ON PACKAGING FOR THE GOODS THAT IS NOT PART OF THE MARK AND IS SHOWN IN BROKEN LINES TO INDICATE THE POSITION OR PLACEMENT OF THE MARK ON THE PACKAGING.

THE NON-LATIN CHARACTERS IN THE MARK TRANSLITERATE TO TOMO AND THIS MEANS FRIENDSHIP IN ENGLISH.

FOR COOKIES; CHOCOLATE-COVERED COOKIES; CHOCOLATE-COVERED FORTUNE COOKIES (U.S. CL. 46).

FIRST USE 11-2-2006; IN COMMERCE 11-2-2006.
SUZANNE BLANE, EXAMINING ATTORNEY

SN 85-128,313. LEIBA, ISHAY ALEX, RISHON LEZION, ISRAEL, FILED 9-13-2010.

BIBLICAL JERUSALEM BALSAM

THE MARK CONSISTS OF STANDARD CHARACTERS WITHOUT CLAIM TO ANY PARTICULAR FONT, STYLE, SIZE, OR COLOR.

PRIORITY CLAIMED UNDER SEC. 44(D) ON ISRAEL APPLICATION NO. 228283, FILED 3-11-2010, REG. NO. 228283, DATED 1-1-2012, EXPIRES 1-1-2022.

NO CLAIM IS MADE TO THE EXCLUSIVE RIGHT TO USE "JERUSALEM BALSAM", APART FROM THE MARK AS SHOWN.

FOR BALSAM VINEGAR, FRUIT VINEGAR, ADDITIVES FOR FOODSTUFFS, NAMELY, BASIL, HYSSOP, CARDAMOM, CORIANDER, CINNAMON, MYRRH, MYRTLE, OREGANO, THYME, BUSAC, NASTURTIUM, LICORICE (U.S. CL. 46).

HEATHER BIDDULPH, EXAMINING ATTORNEY

CLASS 30—(Continued).

SN 85-248,714. DODDATO, RACHAEL, MONROE, NC. FILED 2-22-2011.



NO CLAIM IS MADE TO THE EXCLUSIVE RIGHT TO USE "TREATS CHOCOLATE CHIP COOKIES" AND THE PICTORIAL REPRESENTATION OF THE COOKIES, APART FROM THE MARK AS SHOWN.

THE COLOR(S) BLUE, RED, YELLOW, GREEN, ORANGE, PURPLE, BLACK, TAN AND BROWN IS/ARE CLAIMED AS A FEATURE OF THE MARK.

THE MARK CONSISTS OF THE WORDING "SNEAKIE TREATS CHOCOLATE CHIP CHOCOLATE CHIP COOKIES", THE DESIGN OF TWO CHILDREN APPEARING INSIDE OF AN OVAL, AND A PHOTOGRAPHIC REPRESENTATION OF A PILE OF COOKIES. THE LETTERS IN "SNEAKIES TREATS" APPEAR IN BLUE, RED, YELLOW, GREEN, ORANGE, PURPLE, BLUE, RED, YELLOW, GREEN, ORANGE, PURPLE AND BLUE, RESPECTIVELY, AND WITH BLACK OUTLINING. THE CHILDREN APPEAR INSIDE OF A RED AND BLUE OVAL. THE CHILD ON THE LEFT HAS BLACK HAIR AND BROWN SKIN WITH BLACK LINED FEATURES AND THE CHILD ON THE RIGHT HAS YELLOW HAIR WITH A PURPLE RIBBON AND TAN SKIN WITH A AND BLACK LINED FEATURES. THE WORDING "CHOCOLATE CHIP" APPEARS IN BROWN AND BLACK. THE WORDING "COOKIES" APPEARS IN YELLOW WITH BLACK OUTLINING AND INSIDE OF A PURPLE AND GREEN RECTANGLE. THE COOKIES APPEAR IN BROWN, TAN AND BLACK.

FOR COOKIES CONTAINING REAL MEAT IN THEM IN ORDER TO DISGUISE THE MEAT TASTE FROM CHILDREN AND INCREASE THEIR PROTEIN CONSUMPTION (U.S. CL. 46).

SEAN CROWLEY, EXAMINING ATTORNEY

SN 85-257,272. JOE DIMAGGIO, LLC, HOLLYWOOD, FL. FILED 3-3-2011.

JOLTIN' JOE

THE MARK CONSISTS OF STANDARD CHARACTERS WITHOUT CLAIM TO ANY PARTICULAR FONT, STYLE, SIZE, OR COLOR.

THE NAME(S), PORTRAIT(S), AND/OR SIGNATURE(S) SHOWN IN THE MARK DOES NOT IDENTIFY A PARTICULAR LIVING INDIVIDUAL.

FOR BEVERAGES MADE OF TEA; COFFEE; COFFEE; COFFEE BASED BEVERAGES; COFFEE BEANS; GROUND COFFEE BEANS; ICED COFFEE; ICED TEA; INSTANT COFFEE; INSTANT TEA; TEA; TEA BAGS (U.S. CL. 46).

ELISSA GARBER KON, EXAMINING ATTORNEY

CLASS 30—(Continued).

SN 85-263,140. GRANDY'S, LLC, NASHVILLE, TN. FILED 3-10-2011.

SINNAMON

THE MARK CONSISTS OF STANDARD CHARACTERS WITHOUT CLAIM TO ANY PARTICULAR FONT, STYLE, SIZE, OR COLOR.

FOR BAKERY GOODS FOR CONSUMPTION ON OR OFF THE PREMISES (U.S. CL. 46).

FIRST USE 1-0-1983; IN COMMERCE 1-0-1983. MICHELLE DUBOIS, EXAMINING ATTORNEY

SN 85-265,614. BEE'S KNEES BAKING COMPANY, INC., DBA BEE'S KNEES BAKING COMPANY, BROOKLYN, NY. FILED 3-13-2011.



BEE'S KNEES
BAKING COMPANY

NO CLAIM IS MADE TO THE EXCLUSIVE RIGHT TO USE "BAKING COMPANY", APART FROM THE MARK AS SHOWN.

THE MARK CONSISTS OF A STYLIZED BEE WITH THE WORDS "BEE'S KNEES BAKING COMPANY" BELOW.

FOR BAKERY GOODS (U.S. CL. 46). FIRST USE 7-14-2010; IN COMMERCE 7-14-2010. TOBY BULLOFF, EXAMINING ATTORNEY

SN 85-268,144. COFFEE ROASTERS' ALLIANCE, LLC, ORLANDO, FL. FILED 3-16-2011.

Coffee Roasters' Alliance

THE MARK CONSISTS OF STANDARD CHARACTERS WITHOUT CLAIM TO ANY PARTICULAR FONT, STYLE, SIZE, OR COLOR.

NO CLAIM IS MADE TO THE EXCLUSIVE RIGHT TO USE "COFFEE ROASTERS'", APART FROM THE MARK AS SHOWN.

FOR CAFFEINE-FREE COFFEE; COFFEE; COFFEE BEANS; COFFEE PODS; GROUND COFFEE BEANS (U.S. CL. 46).

FIRST USE 11-10-2009; IN COMMERCE 11-10-2009. MIDGE BUTLER, EXAMINING ATTORNEY

CLASS 30—(Continued).

SN 85-280,590. HESSON, LYNN A., NEENAH, WI. FILED 3-29-2011.



THE MARK CONSISTS OF THE STYLIZED TEXT "SHOCK".

FOR FLAVORED AND COLOR CARBONATED SUGAR CRYSTALS EATEN AS CANDY (U.S. CL. 46).

FIRST USE 7-15-2007; IN COMMERCE 11-15-2007.

JILL PRATER, EXAMINING ATTORNEY

SN 85-285,027. GEL SPICE CO., INC., BAYONNE, NJ. FILED 4-4-2011.



THE MARK CONSISTS OF STANDARD CHARACTERS WITHOUT CLAIM TO ANY PARTICULAR FONT, STYLE, SIZE, OR COLOR.

NO CLAIM IS MADE TO THE EXCLUSIVE RIGHT TO USE "SELECT", APART FROM THE MARK AS SHOWN.

FOR SPICES AND SEASONINGS (U.S. CL. 46).

FIRST USE 7-1-2001; IN COMMERCE 7-1-2001.

SUZANNE BLANE, EXAMINING ATTORNEY

SN 85-285,661. DELICIOUS WORLD CORP., STATEN ISLAND, NY. FILED 4-4-2011.



THE MARK CONSISTS OF THE LETTER "D" AND THE LETTER "W", WITH SHADING TO GIVE THE LETTERS A 3-

CLASS 30—(Continued).

DIMENSIONAL APPEARANCE, AS WELL AS AN IMAGE OF A GLOBE. THE LETTER "D" IS POSITIONED AT A TILTED 3-DIMENSIONAL ANGLE AND PARTIALLY SUPERIMPOSED OVER THE LETTER "W", WITH THE TOP PORTION OF THE LETTER "W" APPEARING WITHIN THE CENTER OF THE LETTER "D", SO AS TO GIVE THE IMPRESSION THAT THE LETTER "D" IS RESTING ON TOP OF AND AROUND THE LETTER "W". THE IMAGE OF THE GLOBE APPEARS OVER THE CENTER OF THE LETTER "W" AND WITHIN THE CENTER OF THE LETTER "D".

FOR ALLSPICE; ALMOND PASTE; ANISEED FOR USE AS A FLAVORING IN FOOD AND DRINKS; AROMATIC PREPARATIONS FOR FOOD, NAMELY, PROCESSED HERBS AND DRIED HERBS; ARTIFICIAL COFFEE; BAKING POWDER; BAKING SODA; CRUSHED BARLEY; HUSKED BARLEY; BARLEY MEAL IN THE NATURE OF BARLEY FLOUR; BEAN MEAL IN THE NATURE OF BEAN PASTE; BEE GLUE FOR HUMAN CONSUMPTION; CHOCOLATE-BASED BEVERAGES; COFFEE-BASED BEVERAGES; FLAVORINGS OTHER THAN ESSENTIAL OILS; TEA-BASED BEVERAGES; BICARBONATE OF SODA FOR COOKING PURPOSES; STARCHED-BASED BINDING AGENTS FOR ICE CREAM; BISCUITS; BREAD; BREAD ROLLS; BREADCRUMBS; BUNS; CAKE PASTE IN THE NATURE OF CAKE FROSTING; CAKE POWDER MIXES; CAKES; EDIBLE DECORATIONS FOR CAKES; FLAVORINGS FOR CAKES OTHER THAN ESSENTIAL OILS; CANDY FOR FOOD; CAPERS; CARAMELS; CELERY SALT; CEREAL-BASED SNACK FOOD; CHEWING GUM NOT FOR MEDICAL PURPOSES; CHICORY FOR USE AS A SUBSTITUTE FOR COFFEE; CHIPS, NAMELY, GRAIN-BASED CHIPS AND FLOUR-BASED CHIPS; CHOCOLATE; CHOW-CHOW IN THE NATURE OF A RELISH; CHUTNEYS; CINNAMON; CLOVES; COCOA; COCOA PRODUCTS, NAMELY, COCOA MIXES AND COCOA POWDER; COFFEE; COFFEE FLAVORINGS; VEGETABLE PREPARATIONS FOR USE AS A COFFEE SUBSTITUTE; CONDIMENTS, NAMELY, PREPARED HORSERADISH; CONFECTIONERY; COOKIES; COOKING SALT; CORN FLAKES; CORN MEAL; MILLED CORN IN THE NATURE OF PROCESSED CORN; POPCORN; ROASTED CORN; COUSCOUS; CRACKERS; CURRY; CUSTARD; SALAD DRESSINGS; EDIBLE ICES; ESSENCES FOR FOODSTUFFS, EXCEPT ETHERIC ESSENCES AND ESSENTIAL OILS; FARINACEOUS FOOD PASTES FOR HUMAN CONSUMPTION; OAT FLAKES; FLAVORINGS, OTHER THAN ESSENTIAL OILS, FOR BEVERAGES; FLOUR; FONDANTS; FROZEN YOGURT; FRUIT JELLIES; GARDEN HERBS; PRESERVED GINGER; GINGERBREAD; GLUCOSE FOR FOOD; GLUTEN FOR FOOD; GOLDEN SYRUP; MEAT GRAVIES; GROATS IN THE NATURE OF GRAINS FOR HUMAN FOOD; GRUEL, WITH A MILK BASE, FOR FOOD; HALVAH; HOMINY; HOMINY GRITS; HONEY; HUSKED BARLEY; HUSKED OATS; ICE CREAM; BINDING AGENTS FOR EDIBLE ICE; EDIBLE ICE; ICE CREAM POWDER; ROYAL JELLY FOR HUMAN CONSUMPTION, NOT FOR MEDICAL PURPOSES; KETCHUP; LEAVEN; LIQUORICE; NON-MEDICATED LOZENGES; MALT BISCUITS; MALT EXTRACT FOR FOOD; MALT FOR HUMAN CONSUMPTION FOR FOOD PURPOSES; MALTOSE; MAYONNAISE; MEAT PIES; MEAT TENDERIZERS FOR HOUSEHOLD PURPOSES; MINT FOR CONFECTIONERY IN THE NATURE OF CANDY MINTS; MOLASSES FOR FOOD; MUESLI; MUSTARD; NUTMEG; OAT FLAKES; OATMEAL; CRUSHED ROLLED OATS; PANCAKES; PASTA; SOYA BEAN PASTE; PASTRIES; PASTY IN THE NATURE OF A FILLED PASTRY; PEPPER; PEPPERMINT SWEETS; PIES; PIZZAS; POTATO FLOUR FOR FOOD; PRALINES; SALT FOR PRESERVING FOODSTUFFS; PROPOLIS FOR HUMAN CONSUMPTION; PUDDINGS IN THE NATURE OF DESSERT PUDDINGS; QUICHES; RELISH; RICE; RICE CAKES; RICE-BASED SNACK FOOD; RUSKS; SAFFRON; SAGO; SANDWICHES; SAUCES; SEA WATER FOR COOKING; SEASONINGS; PRO-

CLASS 30—(Continued).

CESSED SEMOLINA; SHERBETS; SORBETS; SOYA FLOUR; SOYA SAUCE; SPICES; SPRING ROLLS; STAR ANISEED FOR USE AS A FLAVORING IN FOOD AND DRINKS; STARCH FOR USE IN MANUFACTURING FOOD; STARCH-BASED THICKENERS FOR WHIPPED CREAM; SUGAR; SUSHI; NATURAL SWEETENERS; SWEETMEATS; TABBOULEH; TACOS; TAPIOCA; TEA; THICKENING AGENTS FOR COOKING FOODSTUFFS; TORTILLAS; TURMERIC FOR FOOD; VANILLA; VANILLIN IN THE NATURE OF VANILLA FLAVORINGS; VINEGAR; WAFFLES; YEAST NOT FOR MEDICAL USE (U.S. CL. 46).

EMILY CHUO, EXAMINING ATTORNEY

SN 85-292,368. LOERA, JUAN, ROCKLIN, CA. FILED 4-11-2011.

MAYAN WINDS SIGNATURE COFFEES

THE MARK CONSISTS OF STANDARD CHARACTERS WITHOUT CLAIM TO ANY PARTICULAR FONT, STYLE, SIZE, OR COLOR.

NO CLAIM IS MADE TO THE EXCLUSIVE RIGHT TO USE "MAYAN" AND "SIGNATURE COFFEES", APART FROM THE MARK AS SHOWN.

FOR COFFEE (U.S. CL. 46).

FIRST USE 7-4-2004; IN COMMERCE 7-4-2005.

HAI-LY LAM, EXAMINING ATTORNEY

SN 85-297,899. PARSONS, JOSEPH T, LAUDERDALE BY THE SEA, FL. FILED 4-18-2011.



NO CLAIM IS MADE TO THE EXCLUSIVE RIGHT TO USE "TACOS", APART FROM THE MARK AS SHOWN.

THE COLOR(S) ORANGE, GOLD, BROWN, BLUE AND BURGUNDY IS/ARE CLAIMED AS A FEATURE OF THE MARK.

THE MARK CONSISTS OF A GOLD SUN WITH AN OUTER ORANGE BORDER CONTAINING A SMALL REPEATED GEOMETRIC DESIGN WITH BLUE WAVES EMANATING FROM IT WITH A BROWN KOKOPELLI CHARACTER IN THE CENTER AND THE WORDS "JOJO'S TACOS" IN BURGUNDY ACROSS THE DESIGN. THE ENTIRE MARK IS SET AGAINST A TRANSPARENT BACKGROUND.

FOR TACOS (U.S. CL. 46).

FIRST USE 11-1-2010; IN COMMERCE 11-1-2010.

TOBY BULLOFF, EXAMINING ATTORNEY

CLASS 30—(Continued).

SN 85-298,444. PERFECTION BAKERIES, INC., FORT WAYNE, IN. FILED 4-19-2011.

NATURAL 10

THE MARK CONSISTS OF STANDARD CHARACTERS WITHOUT CLAIM TO ANY PARTICULAR FONT, STYLE, SIZE, OR COLOR.

NO CLAIM IS MADE TO THE EXCLUSIVE RIGHT TO USE "NATURAL", APART FROM THE MARK AS SHOWN. FOR BREAD AND OTHER BAKERY PRODUCTS (U.S. CL. 46).

TRACY WHITTAKER-BROWN, EXAMINING ATTORNEY

SN 85-299,240. DIMPLE ORGANICS LLC, WEST JORDAN, UT. FILED 4-19-2011.

SAFFRON VALLEY

THE MARK CONSISTS OF STANDARD CHARACTERS WITHOUT CLAIM TO ANY PARTICULAR FONT, STYLE, SIZE, OR COLOR.

FOR FOOD PRODUCTS, NAMELY, SPICES AND SPICE BLENDS, SAUCES, CANDIES AND CHOCOLATE AND FROZEN CONFECTIONS (U.S. CL. 46).

ALYSSA STEEL, EXAMINING ATTORNEY

SN 85-299,360. SUNSWEET GROWERS INC., YUBA CITY, CA. FILED 4-19-2011.

AMAZIN BRAN

THE MARK CONSISTS OF STANDARD CHARACTERS WITHOUT CLAIM TO ANY PARTICULAR FONT, STYLE, SIZE, OR COLOR.

NO CLAIM IS MADE TO THE EXCLUSIVE RIGHT TO USE "BRAN", APART FROM THE MARK AS SHOWN.

FOR READY-TO-EAT CEREALS, PASTRIES, COOKIES, BREAD (U.S. CL. 46).

ANTHONY RINKER, EXAMINING ATTORNEY

CLASS 30—(Continued).

SN 85-302,825. CREISAT, MEEDO, LOS ANGELES, CA. FILED 4-23-2011.



THE COLOR(S) GREEN, PINK AND DARK PINK IS/ARE CLAIMED AS A FEATURE OF THE MARK.

THE MARK CONSISTS OF A SWIRL DESIGN DEPICTING A BERRY IN THE COLOR GREEN WITH A TWO PRONGED STEM IN THE COLORS PINK AND DARK PINK; THE WORD "BERRYLAND" IS WRITTEN TO THE RIGHT HAND SIDE OF THE IMAGE WITH THE WORD "BERRY" SHOWN IN THE COLOR PINK AND THE WORD "LAND" SHOWN IN THE COLOR GREEN.

FOR FROZEN YOGURT, COFFEE, TEA, COCOA, CAKES, CUPCAKES, CANDY, CHOCOLATE COVERED NUTS, CINNAMON-COATED NUTS, SUGARED NUTS, YOGURT-COVERED NUTS, YOGURT-COVERED FRUIT, CHOCOLATE COVERED FRUIT, COCONUT-BASED FRUIT ICE SUGAR, RICE, TAPIOCA, SAGO, FLOUR, PREPARATIONS MADE FROM CEREALS, BREAD, PASTRY, CONFECTIONERY, ICE, HONEY, TREACLE, YEAST, BAKING POWDER, SALT, MUSTARD, VINEGAR, SAUCES, SPICES (U.S. CL. 46).

LINDA E. BLOHM, EXAMINING ATTORNEY

SN 85-303,057. LOEWENBERG MATTHIAS F, HOLMDEL, NJ, AND LOEWENBERG MEEGAN A, HOLMDEL, NJ. FILED 4-24-2011.

Sweet Excuses

THE MARK CONSISTS OF STANDARD CHARACTERS WITHOUT CLAIM TO ANY PARTICULAR FONT, STYLE, SIZE, OR COLOR.

NO CLAIM IS MADE TO THE EXCLUSIVE RIGHT TO USE "SWEET", APART FROM THE MARK AS SHOWN.

FOR BAKERY GOODS, NAMELY, SWEET AND UNSWEET BAKERY GOODS; CUPCAKES THAT CONTAIN ALCOHOL; EDIBLE CUPCAKE LINERS THAT BAKE ONTO THE CUPCAKE ITSELF (U.S. CL. 46).

SEAN CROWLEY, EXAMINING ATTORNEY

CLASS 30—(Continued).

SN 85-305,560. ALLYSON AMES COMPANY, INC., CORONA DEL MAR, CA. FILED 4-27-2011.

ALLYSON AMES

THE MARK CONSISTS OF STANDARD CHARACTERS WITHOUT CLAIM TO ANY PARTICULAR FONT, STYLE, SIZE, OR COLOR.

THE NAME "ALLYSON AMES" IDENTIFIES A LIVING INDIVIDUAL WHOSE CONSENT IS OF RECORD.

FOR STAPLE FOODS, NAMELY, PRE-PACKAGED BAKING MIXES, FROSTING, ICING, SPRINKLES, EDIBLE DECORATIONS FOR CAKES, FLAVORINGS OTHER THAN ESSENTIAL OILS; CHOCOLATE, CANDY, FLAVORED AND SWEETENED GELATINS, PUDDING, SPICES, CRACKERS, TORTILLA CHIPS, BREAKFAST CEREALS, FLOUR, SUGAR, COCOA, BAKING SODA, BAKING POWDER, SALT, MERINGUE POWDER, TEA, PASTA, COOKIES, COOKIE ARRANGEMENTS, BROWNIES, CUPCAKES, PIES, CAKES, CHEESECAKES, RICE CEREAL TREATS, TARTS, PASTRIES, ARTISTIC BAKERY DESSERTS, DONUTS, RICE CAKES (U.S. CL. 46).

FIRST USE 1-1-2005; IN COMMERCE 1-1-2011.

JANICE L. MCMORROW, EXAMINING ATTORNEY

SN 85-306,959. GRUPO BIMBO, S.A.B. DE C.V., MEXICO CITY, MEXICO, FILED 4-28-2011.



OWNER OF U.S. REG. NOS. 2,374,912, 3,847,239 AND OTHERS.

NO CLAIM IS MADE TO THE EXCLUSIVE RIGHT TO USE "NEW LOOK", "CHILE & LIME", AND THE PICTORIAL REPRESENTATION OF THE CHILI PEPPERS, LIMES, AND SNACK STICKS, APART FROM THE MARK AS SHOWN.

THE COLOR(S) BLACK, WHITE, GREEN, RED, YELLOW, BROWN, ORANGE, GRAY AND BLUE IS/ARE CLAIMED AS A FEATURE OF THE MARK.

THE MARK CONSISTS OF THE WORD "CHURRITOS" IN WHITE AND GRAY LETTERS WITH GRAY AND ORANGE HIGHLIGHTS OUTLINED IN BLACK, INSIDE OF A BLACK, BROWN AND YELLOW BANNER, OVER AN IMAGE OF SNACK STICKS IN VARIOUS SHADES OF BROWN, BLACK AND ORANGE. TWO GREEN, WHITE, AND YELLOW SLICED LIMES AND THREE RED, BROWN, BLACK AND GREEN PEPPERS ARE UNDER THE BANNER, ON TOP OF AN IRREGULAR YELLOW BACKGROUND. THE WORDS "CHILE & LIME" IN WHITE LETTERS OUTLINED IN BLACK ARE UNDER THE PEPPERS. THE BACKGROUND CONSISTS OF AN ORANGE, YELLOW AND RED SWIRL DESIGN, WITH WHITE AREAS AND YELLOW AND WHITE SPARKLES. IN THE

CLASS 30—(Continued).

UPPER LEFT IS A RED QUADRILATERAL WITH WHITE OUTLINE CONTAINING A WHITE "B" AND "BARCEL" IN YELLOW, ALL WITH BLUE SHADOWS. IN THE UPPER RIGHT ARE THE WORDS "NEW LOOK", WITH "NEW" IN YELLOW AND "LOOK" IN WHITE, ON A BLACK BACKGROUND WITH RED OUTLINE. THE MARK REPRESENTS DESIGN FEATURES OF PACKAGING; THE CONFIGURATION OF THE PACKAGING ITSELF, AS REPRESENTED BY DOTTED LINES, IS NOT CLAIMED AS A FEATURE OF THE MARK.

THE ENGLISH TRANSLATION OF "CHURRITOS" IN THE MARK IS "FRITTERS" OR "CRULLERS".

SEC. 2(F) AS TO "CHURRITOS".

FOR NON-WHEAT FLOUR BASED, CRUNCHY FLAVORED SNACK STICKS MADE FROM CORN (U.S. CL. 46).

FIRST USE 1-31-2002; IN COMMERCE 1-31-2002.

ROBIN MITTLER, EXAMINING ATTORNEY

SN 85-311,646. ALLYSON AMES COMPANY, INC., CORONA DEL MAR, CA. FILED 5-4-2011.

WONDERLICIOUS

THE MARK CONSISTS OF STANDARD CHARACTERS WITHOUT CLAIM TO ANY PARTICULAR FONT, STYLE, SIZE, OR COLOR.

OWNER OF U.S. REG. NO. 3,629,516.

FOR STAPLE FOODS, NAMELY, PRE-PACKAGED BAKING MIXES, FROSTING, ICING, SPRINKLES, EDIBLE DECORATIONS FOR CAKES, FLAVORINGS OTHER THAN ESSENTIAL OILS; CHOCOLATE, CANDY, FLAVORED AND SWEETENED GELATINS, PUDDING, SPICES, CRACKERS, TORTILLA CHIPS, BREAKFAST CEREALS, FLOUR, SUGAR, COCOA, BAKING SODA, BAKING POWDER, SALT, MERINGUE POWDER, TEA, PASTA, COOKIES, COOKIE ARRANGEMENTS, BROWNIES, CUPCAKES, PIES, CAKES, CHEESECAKES, RICE CEREAL TREATS, TARTS, PASTRIES, ARTISTIC BAKERY DESSERTS, DONUTS, RICE CAKES (U.S. CL. 46).

FIRST USE 1-1-2005; IN COMMERCE 1-1-2011.

JANICE L. MCMORROW, EXAMINING ATTORNEY

CLASS 30—(Continued).

SN 85-315,076. HART INDUSTRIES, INC., PUYALLUP, WA. FILED 5-7-2011.

Tea Yankee

THE MARK CONSISTS OF STANDARD CHARACTERS WITHOUT CLAIM TO ANY PARTICULAR FONT, STYLE, SIZE, OR COLOR.

FOR ARTIFICIAL COFFEE AND TEA; BEVERAGES MADE OF TEA; BEVERAGES WITH A TEA BASE; BLACK TEA; CHAI TEA; COFFEE AND TEA; DISPOSABLE CUPS WITH A TEA-FILLED POUCH ULTRASONICALLY WELDED TO ONE SIDE OF THE BOTTOM OF THE CUP, WHICH ALLOWS THE NATURAL FIBER POUCH TO FLOAT NEAR THE BOTTOM; FLAVOURINGS OF TEA; FRUIT TEAS; GINSENG TEA; GREEN TEA; HERB TEA; HERBAL TEA; ICED TEA; INSTANT TEA; JAPANESE GREEN TEA; LIME TEA; MIXES IN THE NATURE OF CONCENTRATES, SYRUPS OR POWDERS USED IN THE PREPARATION OF TEA BASED BEVERAGES; OOLONG TEA; SAGE TEA; SYRUPS FOR MAKING TEA; TEA; TEA BAGS; TEA EXTRACTS; TEA FOR INFUSIONS; TEA OF PARCHED POWDER OF BARLEY WITH HUSK (MUGI-CHA); TEA OF SALTY KELP POWDER (KOMBU-CHA); TEA PODS; TEA SUBSTITUTES; TEA-BASED BEVERAGES; TEA-BASED BEVERAGES WITH FRUIT FLAVORING; THEINE-FREE TEA SWEETENED WITH SWEETENERS (U.S. CL. 46).

FIRST USE 4-1-2011; IN COMMERCE 4-1-2011.

CARRIE GENOVESE, EXAMINING ATTORNEY

SN 85-316,299. DON SABROSA, CINCINNATI, OH. FILED 5-9-2011.



THE NAME(S), PORTRAIT(S), AND/OR SIGNATURE(S) SHOWN IN THE MARK DOES NOT IDENTIFY A PARTICULAR LIVING INDIVIDUAL.

THE MARK CONSISTS OF AN OVAL WITH A SOMBRERO AND THE STYLIZED TEXT "DON SABROSA".

THE ENGLISH TRANSLATION OF "DON SABROSA" IN THE MARK IS MR. FLAVORFUL.

FOR BARBECUE SAUCE; JAMBALAYA, NAMELY, A SPICY CREOLE RICE DISH WITH A MIXTURE OF FISH AND MEAT SUCH AS SHRIMP, CHICKEN, HAM AND SPICY SAUSAGE; KETCHUP; MARINADES; SALAD DRESSING; SALSA; SAUCES; SPAGHETTI SAUCE; TORTILLA CHIPS (U.S. CL. 46).

FIRST USE 11-1-2008; IN COMMERCE 11-1-2008.

RON FAIRBANKS, EXAMINING ATTORNEY

CLASS 30—(Continued).

SN 85-321,736. URBANI TARTUFI S.R.L., PERUGIA, ITALY,
FILED 5-16-2011.

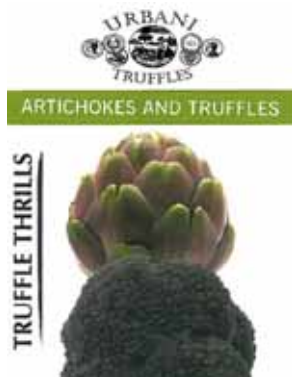

OWNER OF U.S. REG. NOS. 2,977,165, 3,995,978 AND OTHERS.

NO CLAIM IS MADE TO THE EXCLUSIVE RIGHT TO USE "TRUFFLE", "TRUFFLES", "ARTICHOKE AND TRUFFLES", "MARCA DI FABBRICA", "ESPOSIZIONE INTERNAZIONALE TORINO 1911", "PARIGI 1910", "ESPOS. INTERNAZIONALE IN ROMA 1912 TORINO 1911" AND THE DEPICTION OF THE ARTICHOKE AND TRUFFLE, APART FROM THE MARK AS SHOWN.

THE NAMES "VITTORIO EMANUELE" AND "PAOLO URBANI" DO NOT IDENTIFY LIVING INDIVIDUALS.

THE COLOR(S) GREEN, BLACK, AND WHITE IS/ARE CLAIMED AS A FEATURE OF THE MARK.

THE MARK CONSISTS OF THE STYLIZED, BLACK WORDING "URBANI" APPEARING ABOVE THE STYLIZED, BLACK WORDING "TRUFFLES". IN BETWEEN THE WORDING "URBANI" AND "TRUFFLES" IS THE DEPICTION OF TWO GROUPS OF THREE BLACK AND WHITE COINS SEPARATED BY A CIRCLE CONTAINING THE BLACK AND WHITE DEPICTION OF A FARMER WORKING THE FIELDS WITH A DOG IN FRONT OF TICKET OF TREES. LOCATED BELOW THE FARMER AND DOG IN THE FIELD IS A WHITE BANNER CONTAINING THE BLACK WORDING "MARCA DI FABBRICA". THE THREE COINS APPEARING TO THE LEFT OF THE FARMER AND DOG IN THE FIELD ARE ARRANGED IN A TRIANGLE. THE LEFT MOST COIN COMPRISES THE BUST OF A HEAD WITH THE WORDING "VITTORIO EMANUELE ILL RE D'ITALIA", TO THE RIGHT OF THIS COIN APPEARS ANOTHER COIN CONTAINING THE DEPICTION OF A WREATH WITH THE WORDING "ESPOS. INTERNAZIONALE IN ROMA 1912 TORINO 1911" BELOW THAT COIN IS ANOTHER COIN CONTAINING THE DEPICTION OF NON-DESCRIPT PERSON SITTING IN FRONT OF BUILDING. THE THREE COINS APPEARING TO THE RIGHT OF THE FARMER AND DOG IN THE FIELD ARE ALSO ARRANGED IN A TRIANGLE. THE RIGHTMOST COIN COMPRISES THE BUST OF A HEAD, TO THE LEFT OF THIS COIN APPEARS ANOTHER COIN CONTAINING THE CIRCULAR WORDING "ESPOSIZIONE INTERNAZIONALE TORINO 1911" SURROUNDING THE WORDING "A PAOLO URBANI" BELOW THIS COIN APPEARS ANOTHER COIN CONTAINING THE DEPICTION OF A WREATH AND BANNER INSIDE WHICH IS THE WORDING "PARIGI 1911". THE COINS, WORDING IN THE COINS AS WELL AS THE IMAGES IN THE COINS ARE IN THE COLORS BLACK AND WHITE. BELOW THE BLACK WORDING "TRUFFLES" IS A GREEN RECTANGULAR BAND CONTAINING THE WHITE WORDING "ARTICHOKE AND TRUFFLES". BELOW THE GREEN BAND IS THE DEPICTION OF A GREEN AND BLACK ARTICHOKE LOCATED ABOVE THE DEPICTION OF A

CLASS 30—(Continued).

BLACK TRUFFLE. TO THE LEFT OF THE DEPICTION OF THE ARTICHOKE AND TRUFFLE IS THE STYLIZED, BLACK WORDING "TRUFFLE THRILLS" WITH A BLACK UNDERLINE ARRANGED VERTICALLY FROM THE BOTTOM. OTHER THAN THE COLOR WHITE APPEARING IN THE DEPICTION OF THE COINS, THE DEPICTION OF THE FARMER AND DOG IN THE FIELD, AND THE WORDING "ARTICHOKE AND TRUFFLES" THE COLOR WHITE REPRESENTS BACKGROUND OR TRANSPARENT AREAS OF THE MARK AND IS NOT PART OF THE MARK.

THE ENGLISH TRANSLATION OF "URBANI" IS "CITIZENS OF THE TOWN"; THE ENGLISH TRANSLATION OF "ESPOSIZIONE INTERNAZIONALE TORINO 1911 A PAOLO URBANI" IS "INTERNATIONAL EXHIBITION TURIN 1911 TO PAOLO URBANI"; THE ENGLISH TRANSLATION OF "PARIGI 1910" IS "PARIS 1910"; THE ENGLISH TRANSLATION OF "MARCA DI FABBRICA" IS "BRAND" OR "TRADEMARK"; THE ENGLISH TRANSLATION OF "VITTORIO EMANUELE ILL RE D'ITALIA" IS "VITTORIO EMANUELE THE THIRD KING OF ITALY"; THE ENGLISH TRANSLATION OF "ESPOS. INTERNAZIONALE IN ROMA 1912 TORINO 1911" IS "INTERNATIONAL EXHIBITION IN ROME 1912 TURIN 1911".

FOR SAUCES AND SALAD DRESSINGS CONTAINING TRUFFLES AND ARTICHOKE (U.S. CL. 46).

FIRST USE 11-30-2009; IN COMMERCE 11-30-2009.

MICHAEL TANNER, EXAMINING ATTORNEY

SN 85-321,804. URBANI TARTUFI S.R.L., PERUGIA, ITALY,
FILED 5-16-2011.



OWNER OF U.S. REG. NOS. 2,977,165, 3,995,978 AND OTHERS.

NO CLAIM IS MADE TO THE EXCLUSIVE RIGHT TO USE "TRUFFLE", "TRUFFLES", "BLACK TRUFFLES AND MUSHROOMS", "MARCA DI FABBRICA", "ESPOSIZIONE INTERNAZIONALE TORINO 1911", "PARIGI 1910", "ESPOS. INTERNAZIONALE IN ROMA 1912 TORINO 1911" AND THE DEPICTION OF THE TWO MUSHROOMS AND TRUFFLE, APART FROM THE MARK AS SHOWN.

THE NAMES "VITTORIO EMANUELE" AND "PAOLO URBANI" DO NOT IDENTIFY LIVING INDIVIDUALS.

THE COLOR(S) TAN, BLACK, WHITE AND GREY IS/ARE CLAIMED AS A FEATURE OF THE MARK.

THE MARK CONSISTS OF THE STYLIZED, BLACK WORDING "URBANI" APPEARING ABOVE THE STYLIZED, BLACK WORDING "TRUFFLES". IN BETWEEN THE WORDING "URBANI" AND "TRUFFLES" IS THE DEPICTION OF TWO GROUPS OF THREE BLACK AND WHITE COINS SEPARATED BY A CIRCLE CONTAINING THE BLACK AND WHITE DEPICTION OF A FARMER WORKING THE FIELDS WITH A DOG IN FRONT OF TICKET OF TREES. LOCATED BELOW THE FARMER AND DOG IN THE FIELD IS A WHITE BANNER CONTAINING THE BLACK WORDING "MARCA DI FABBRICA". THE THREE COINS APPEARING TO THE LEFT OF THE FARMER AND DOG IN THE FIELD ARE ARRANGED IN A TRIANGLE. THE LEFT MOST COIN COMPRISES THE BUST OF A HEAD WITH THE WORDING "VITTORIO EMANUELE ILL RE D'ITALIA", TO THE RIGHT OF THIS COIN APPEARS ANOTHER COIN CONTAINING THE

CLASS 30—(Continued).

DEPICTION OF A WREATH WITH THE WORDING "ESPOS. INTERNAZIONALE IN ROMA 1912 TORINO 1911" BELOW THAT COIN IS ANOTHER COIN CONTAINING THE DEPICTION OF NON-DESCRIPT PERSON SITTING IN FRONT OF BUILDING. THE THREE COINS APPEARING TO THE RIGHT OF THE FARMER AND DOG IN THE FIELD ARE ALSO ARRANGED IN A TRIANGLE. THE RIGHTMOST COIN COMPRISES THE BUST OF A HEAD, TO THE LEFT OF THIS COIN APPEARS ANOTHER COIN CONTAINING THE CIRCULAR WORDING "ESPOSIZIONE INTERNAZIONALE TORINO 1911" SURROUNDING THE WORDING "A PAOLO URBANI" BELOW THIS COIN APPEARS ANOTHER COIN CONTAINING THE DEPICTION OF A WREATH AND BANNER INSIDE WHICH IS THE WORDING "PARIGI 1911". THE COINS, WORDING IN THE COINS AS WELL AS THE IMAGES IN THE COINS ARE IN THE COLORS BLACK AND WHITE. BELOW THE BLACK WORDING "TRUFFLES" IS A BLACK RECTANGULAR BAND CONTAINING THE WHITE WORDING "BLACK TRUFFLES AND MUSHROOMS". BELOW THE BLACK BAND IS THE DEPICTION OF A TWO TAN, WHITE AND GREY MUSHROOMS LOCATED ABOVE THE DEPICTION OF A BLACK TRUFFLE. TO THE LEFT OF THE DEPICTION OF THE TWO MUSHROOMS AND TRUFFLE IS THE STYLIZED, BLACK WORDING "TRUFFLE THRILLS" WITH A BLACK UNDERLINE ARRANGED VERTICALLY FROM THE BOTTOM. OTHER THAN THE COLOR WHITE APPEARING IN THE DEPICTION OF THE COINS, THE DEPICTION OF THE MUSHROOMS, THE DEPICTION OF THE FARMER AND DOG IN THE FIELD, AND THE WORDING "BLACK TRUFFLES AND MUSHROOMS" THE COLOR WHITE REPRESENTS BACKGROUND OR TRANSPARENT AREAS OF THE MARK AND IS NOT PART OF THE MARK.

THE ENGLISH TRANSLATION OF "URBANI" IS "CITIZENS OF THE TOWN"; THE ENGLISH TRANSLATION OF "ESPOSIZIONE INTERNAZIONALE TORINO 1911 A PAOLO URBANI" IS "INTERNATIONAL EXHIBITION TURIN 1911 TO PAOLO URBANI"; THE ENGLISH TRANSLATION OF "PARIGI 1910" IS "PARIS 1910"; THE ENGLISH TRANSLATION OF "MARCA DI FABBRICA" IS "BRAND OR "TRADEMARK"; THE ENGLISH TRANSLATION OF "VITTORIO EMANUELE ILL RE D'ITALIA" IS "VITTORIO EMANUELE THE THIRD KING OF ITALY"; THE ENGLISH TRANSLATION OF "ESPOS. INTERNAZIONALE IN ROMA 1912 TORINO 1911" IS "INTERNATIONAL EXHIBITION IN ROME 1912 TURIN 1911".

FOR SAUCES AND SALAD DRESSINGS CONTAINING BLACK TRUFFLES AND MUSHROOMS (U.S. CL. 46).

FIRST USE 11-30-2009; IN COMMERCE 11-30-2009.
MICHAEL TANNER, EXAMINING ATTORNEY

CLASS 30—(Continued).

SN 85-321,864. URBANI TARTUFI S.R.L., PERUGIA, ITALY, FILED 5-16-2011.



OWNER OF U.S. REG. NOS. 2,977,165, 3,995,978 AND OTHERS.

NO CLAIM IS MADE TO THE EXCLUSIVE RIGHT TO USE "TRUFFLE", "TRUFFLES", "CREAM AND TRUFFLES", "MARCA DI FABBRICA", "ESPOSIZIONE INTERNAZIONALE TORINO 1911", "PARIGI 1910", "ESPOS. INTERNAZIONALE IN ROMA 1912 TORINO 1911" AND THE DEPICTION OF THE PUDDLE OF POURED CREAM AND TRUFFLE, APART FROM THE MARK AS SHOWN.

THE NAMES "VITTORIO EMANUELE" AND "PAOLO URBANI" DO NOT IDENTIFY LIVING INDIVIDUALS.

THE COLOR(S) BLACK, WHITE AND GREY IS/ARE CLAIMED AS A FEATURE OF THE MARK.

THE MARK CONSISTS OF THE STYLIZED, BLACK WORDING "URBANI" APPEARING ABOVE THE STYLIZED, BLACK WORDING "TRUFFLES". IN BETWEEN THE WORDING "URBANI" AND "TRUFFLES" IS THE DEPICTION OF TWO GROUPS OF THREE BLACK AND WHITE COINS SEPARATED BY A CIRCLE CONTAINING THE BLACK AND WHITE DEPICTION OF A FARMER WORKING THE FIELDS WITH A DOG IN FRONT OF TICKET OF TREES. LOCATED BELOW THE FARMER AND DOG IN THE FIELD IS A WHITE BANNER CONTAINING THE BLACK WORDING "MARCA DI FABBRICA". THE THREE COINS APPEARING TO THE LEFT OF THE FARMER AND DOG IN THE FIELD ARE ARRANGED IN A TRIANGLE. THE LEFT MOST COIN COMPRISES THE BUST OF A HEAD WITH THE WORDING "VITTORIO EMANUELE ILL RE D'ITALIA". TO THE RIGHT OF THIS COIN APPEARS ANOTHER COIN CONTAINING THE DEPICTION OF A WREATH WITH THE WORDING "ESPOS. INTERNAZIONALE IN ROMA 1912 TORINO 1911" BELOW THAT COIN IS ANOTHER COIN CONTAINING THE DEPICTION OF NON-DESCRIPT PERSON SITTING IN FRONT OF BUILDING. THE THREE COINS APPEARING TO THE RIGHT OF THE FARMER AND DOG IN THE FIELD ARE ALSO ARRANGED IN A TRIANGLE. THE RIGHTMOST COIN COMPRISES THE BUST OF A HEAD, TO THE LEFT OF THIS COIN APPEARS ANOTHER COIN CONTAINING THE CIRCULAR WORDING "ESPOSIZIONE INTERNAZIONALE TORINO 1911" SURROUNDING THE WORDING "A PAOLO URBANI" BELOW THIS COIN APPEARS ANOTHER COIN CONTAINING THE DEPICTION OF A WREATH AND BANNER INSIDE WHICH IS THE WORDING "PARIGI 1911". THE COINS, WORDING IN THE COINS AS WELL AS THE IMAGES IN THE COINS ARE IN THE COLORS BLACK AND WHITE. BELOW THE BLACK WORDING "TRUFFLES" IS A GREY RECTANGULAR BAND CONTAINING THE WHITE WORDING "CREAM AND TRUFFLES". BELOW THE GREY BAND IS THE DEPICTION OF A PUDDLE OF POURED WHITE CREAM WITH GREY SHADING LOCATED ABOVE THE DEPICTION OF A BLACK TRUFFLE. TO THE LEFT OF THE DEPICTION OF THE POURED CREAM AND TRUF-

CLASS 30—(Continued).

FLE IS THE STYLIZED, BLACK WORDING "TRUFFLE THRILLS" WITH A BLACK UNDERLINE ARRANGED VERTICALLY FROM THE BOTTOM. OTHER THAN THE COLOR WHITE APPEARING IN THE DEPICTION OF THE COINS, THE DEPICTION OF THE PUDDLE OF POURED CREAM, THE DEPICTION OF THE FARMER AND DOG IN THE FIELD, AND THE WORDING "CREAM AND TRUFFLES" THE COLOR WHITE REPRESENTS BACKGROUND OR TRANSPARENT AREAS OF THE MARK AND IS NOT PART OF THE MARK.

THE ENGLISH TRANSLATION OF "URBANI" IS "CITIZENS OF THE TOWN"; THE ENGLISH TRANSLATION OF "ESPOSIZIONE INTERNAZIONALE TORINO 1911 A PAOLO URBANI" IS "INTERNATIONAL EXHIBITION TURIN 1911 TO PAOLO URBANI"; THE ENGLISH TRANSLATION OF "PARIGI 1910" IS "PARIS 1910"; THE ENGLISH TRANSLATION OF "MARCA DI FABBRICA" IS "BRAND OR "TRADEMARK"; THE ENGLISH TRANSLATION OF "VITTORIO EMANUELE ILL RE D'ITALIA" IS "VITTORIO EMANUELE THE THIRD KING OF ITALY"; THE ENGLISH TRANSLATION OF "ESPOS. INTERNAZIONALE IN ROMA 1912 TORINO 1911" IS "INTERNATIONAL EXHIBITION IN ROME 1912 TURIN 1911".

FOR SAUCES AND SALAD DRESSINGS CONTAINING CREAM AND TRUFFLES (U.S. CL. 46).

FIRST USE 11-30-2009; IN COMMERCE 11-30-2009.

MICHAEL TANNER, EXAMINING ATTORNEY

SN 85-321,931. URBANI TARTUFI S.R.L., PERUGIA, ITALY, FILED 5-16-2011.



OWNER OF U.S. REG. NOS. 2,977,165, 3,995,978 AND OTHERS.

NO CLAIM IS MADE TO THE EXCLUSIVE RIGHT TO USE "TRUFFLE", "TRUFFLES", "PESTO AND TRUFFLES", "MARCA DI FABBRICA", "ESPOSIZIONE INTERNAZIONALE TORINO 1911", "PARIGI 1910", "ESPOS. INTERNAZIONALE IN ROMA 1912 TORINO 1911" AND THE DEPICTION OF THE BASIL LEAF AND TRUFFLE, APART FROM THE MARK AS SHOWN.

THE NAMES "VITTORIO EMANUELE" AND "PAOLO URBANI" DO NOT IDENTIFY LIVING INDIVIDUALS.

THE COLOR(S) BLACK, WHITE, GREEN AND GREY IS/ARE CLAIMED AS A FEATURE OF THE MARK.

THE MARK CONSISTS OF THE STYLIZED, BLACK WORDING "URBANI" APPEARING ABOVE THE STYLIZED, BLACK WORDING "TRUFFLES". IN BETWEEN THE WORDING "URBANI" AND "TRUFFLES" IS THE DEPICTION OF TWO GROUPS OF THREE BLACK AND WHITE COINS SEPARATED BY A CIRCLE CONTAINING THE BLACK AND WHITE DEPICTION OF A FARMER WORKING THE FIELDS WITH A DOG IN FRONT OF TICKET OF TREES. LOCATED BELOW THE FARMER AND DOG IN THE FIELD IS A WHITE BANNER CONTAINING THE BLACK WORDING "MARCA DI FABBRICA". THE THREE COINS APPEARING TO THE LEFT OF THE FARMER AND DOG IN THE FIELD ARE ARRANGED IN A TRIANGLE. THE LEFT MOST COIN COMPRISES THE BUST OF A HEAD WITH THE WORDING "VITTORIO EMANUELE ILL RE D'ITALIA", TO THE RIGHT OF THIS COIN APPEARS ANOTHER COIN CONTAINING THE

CLASS 30—(Continued).

DEPICTION OF A WREATH WITH THE WORDING "ESPOS. INTERNAZIONALE IN ROMA 1912 TORINO 1911" BELOW THAT COIN IS ANOTHER COIN CONTAINING THE DEPICTION OF NON-DESCRIPT PERSON SITTING IN FRONT OF BUILDING. THE THREE COINS APPEARING TO THE RIGHT OF THE FARMER AND DOG IN THE FIELD ARE ALSO ARRANGED IN A TRIANGLE. THE RIGHTMOST COIN COMPRISES THE BUST OF A HEAD, TO THE LEFT OF THIS COIN APPEARS ANOTHER COIN CONTAINING THE CIRCULAR WORDING "ESPOSIZIONE INTERNAZIONALE TORINO 1911" SURROUNDING THE WORDING "A PAOLO URBANI" BELOW THIS COIN APPEARS ANOTHER COIN CONTAINING THE DEPICTION OF A WREATH AND BANNER INSIDE WHICH IS THE WORDING "PARIGI 1911". THE COINS, WORDING IN THE COINS AS WELL AS THE IMAGES IN THE COINS ARE IN THE COLORS BLACK AND WHITE. BELOW THE BLACK WORDING "TRUFFLES" IS A GREEN RECTANGULAR BAND CONTAINING THE WHITE WORDING "PESTO AND TRUFFLES". BELOW THE GREEN BAND IS THE DEPICTION OF A GREEN BASIL LEAF WITH GREY AND BLACK SHADING LOCATED ABOVE THE DEPICTION OF A BLACK TRUFFLE. TO THE LEFT OF THE DEPICTION OF THE BASIL LEAF AND TRUFFLE IS THE STYLIZED, BLACK WORDING "TRUFFLE THRILLS" WITH A BLACK UNDERLINE ARRANGED VERTICALLY FROM THE BOTTOM. OTHER THAN THE COLOR WHITE APPEARING IN THE DEPICTION OF THE COINS, THE DEPICTION OF THE FARMER AND DOG IN THE FIELD, AND THE WORDING "PESTO AND TRUFFLES" THE COLOR WHITE REPRESENTS BACKGROUND OR TRANSPARENT AREAS OF THE MARK AND IS NOT PART OF THE MARK.

THE ENGLISH TRANSLATION OF "URBANI" IS "CITIZENS OF THE TOWN"; THE ENGLISH TRANSLATION OF "ESPOSIZIONE INTERNAZIONALE TORINO 1911 A PAOLO URBANI" IS "INTERNATIONAL EXHIBITION TURIN 1911 TO PAOLO URBANI"; THE ENGLISH TRANSLATION OF "PARIGI 1910" IS "PARIS 1910"; THE ENGLISH TRANSLATION OF "MARCA DI FABBRICA" IS "BRAND OR "TRADEMARK"; THE ENGLISH TRANSLATION OF "VITTORIO EMANUELE ILL RE D'ITALIA" IS "VITTORIO EMANUELE THE THIRD KING OF ITALY"; THE ENGLISH TRANSLATION OF "ESPOS. INTERNAZIONALE IN ROMA 1912 TORINO 1911" IS "INTERNATIONAL EXHIBITION IN ROME 1912 TURIN 1911".

FOR SAUCES AND SALAD DRESSINGS CONTAINING PESTO AND TRUFFLES (U.S. CL. 46).

FIRST USE 11-30-2009; IN COMMERCE 11-30-2009.

MICHAEL TANNER, EXAMINING ATTORNEY

CLASS 30—(Continued).

SN 85-321,969. URBANI TARTUFI S.R.L., PERUGIA, ITALY, FILED 5-16-2011.



OWNER OF U.S. REG. NOS. 2,977,165, 3,995,978 AND OTHERS.

NO CLAIM IS MADE TO THE EXCLUSIVE RIGHT TO USE "TRUFFLE", "TRUFFLES", "RED PESTO AND TRUFFLES", "MARCA DI FABBRICA", "ESPOSIZIONE INTERNAZIONALE TORINO 1911", "PARIGI 1910", "ESPOS. INTERNAZIONALE IN ROMA 1912 TORINO 1911" AND THE DEPICTION OF THE TOMATO, BASIL LEAF AND TRUFFLE, APART FROM THE MARK AS SHOWN.

THE NAMES "VITTORIO EMANUELE" AND "PAOLO URBANI" DO NOT IDENTIFY LIVING INDIVIDUALS.

THE COLOR(S) RED, BLACK, WHITE, GREEN AND GREY IS/ARE CLAIMED AS A FEATURE OF THE MARK.

THE MARK CONSISTS OF THE STYLIZED, BLACK WORDING "URBANI" APPEARING ABOVE THE STYLIZED, BLACK WORDING "TRUFFLES". IN BETWEEN THE WORDING "URBANI" AND "TRUFFLES" IS THE DEPICTION OF TWO GROUPS OF THREE BLACK AND WHITE COINS SEPARATED BY A CIRCLE CONTAINING THE BLACK AND WHITE DEPICTION OF A FARMER WORKING THE FIELDS WITH A DOG IN FRONT OF TICKET OF TREES. LOCATED BELOW THE FARMER AND DOG IN THE FIELD IS A WHITE BANNER CONTAINING THE BLACK WORDING "MARCA DI FABBRICA". THE THREE COINS APPEARING TO THE LEFT OF THE FARMER AND DOG IN THE FIELD ARE ARRANGED IN A TRIANGLE. THE LEFT MOST COIN COMPRISES THE BUST OF A HEAD WITH THE WORDING "VITTORIO EMANUELE ILL RE D'ITALIA", TO THE RIGHT OF THIS COIN APPEARS ANOTHER COIN CONTAINING THE DEPICTION OF A WREATH WITH THE WORDING "ESPOS. INTERNAZIONALE IN ROMA 1912 TORINO 1911" BELOW THAT COIN IS ANOTHER COIN CONTAINING THE DEPICTION OF NON-DESCRIPT PERSON SITTING IN FRONT OF BUILDING. THE THREE COINS APPEARING TO THE RIGHT OF THE FARMER AND DOG IN THE FIELD ARE ALSO ARRANGED IN A TRIANGLE. THE RIGHTMOST COIN COMPRISES THE BUST OF A HEAD, TO THE LEFT OF THIS COIN APPEARS ANOTHER COIN CONTAINING THE CIRCULAR WORDING "ESPOSIZIONE INTERNAZIONALE TORINO 1911" SURROUNDING THE WORDING "A PAOLO URBANI" BELOW THIS COIN APPEARS ANOTHER COIN CONTAINING THE DEPICTION OF A WREATH AND BANNER INSIDE WHICH IS THE WORDING "PARIGI 1911". THE COINS, WORDING IN THE COINS AS WELL AS THE IMAGES IN THE COINS ARE IN THE COLORS BLACK AND WHITE. BELOW THE BLACK WORDING "TRUFFLES" IS A RED RECTANGULAR BAND CONTAINING THE WHITE WORDING "RED PESTO AND TRUFFLES". BELOW THE RED BAND IS THE DEPICTION OF A RED TOMATO HAVING A GREEN STEM AND WHITE AND GREY SHADING AS WELL AS THE DEPICTION OF A GREEN BASIL LEAF WITH GREY AND BLACK SHADING BOTH OF WHICH ARE LOCATED ABOVE THE DEPICTION OF A BLACK TRUFFLE. TO THE LEFT OF THE DEPICTION OF THE TOMATO, BASIL

CLASS 30—(Continued).

LEAF AND TRUFFLE IS THE STYLIZED, BLACK WORDING "TRUFFLE THRILLS" WITH A BLACK UNDERLINE ARRANGED VERTICALLY FROM THE BOTTOM. OTHER THAN THE COLOR WHITE APPEARING IN THE DEPICTION OF THE COINS, THE DEPICTION OF THE FARMER AND DOG IN THE FIELD, THE SHADING ON THE DEPICTION OF THE TOMATO AND THE WORDING "RED PESTO AND TRUFFLES" THE COLOR WHITE REPRESENTS BACKGROUND OR TRANSPARENT AREAS OF THE MARK AND IS NOT PART OF THE MARK.

THE ENGLISH TRANSLATION OF "URBANI" IS "CITIZENS OF THE TOWN"; THE ENGLISH TRANSLATION OF "ESPOSIZIONE INTERNAZIONALE TORINO 1911 A PAOLO URBANI" IS "INTERNATIONAL EXHIBITION TURIN 1911 TO PAOLO URBANI"; THE ENGLISH TRANSLATION OF "PARIGI 1910" IS "PARIS 1910"; THE ENGLISH TRANSLATION OF "MARCA DI FABBRICA" IS "BRAND OR TRADEMARK"; THE ENGLISH TRANSLATION OF "VITTORIO EMANUELE ILL RE D'ITALIA" IS "VITTORIO EMANUELE THE THIRD KING OF ITALY"; THE ENGLISH TRANSLATION OF "ESPOS. INTERNAZIONALE IN ROMA 1912 TORINO 1911" IS "INTERNATIONAL EXHIBITION IN ROME 1912 TURIN 1911".

FOR SAUCES AND SALAD DRESSINGS CONTAINING TOMATO, PESTO AND TRUFFLES (U.S. CL. 46).

FIRST USE 11-30-2009; IN COMMERCE 11-30-2009. MICHAEL TANNER, EXAMINING ATTORNEY

SN 85-321,991. URBANI TARTUFI S.R.L., PERUGIA, ITALY, FILED 5-16-2011.



OWNER OF U.S. REG. NOS. 2,977,165, 3,995,978 AND OTHERS.

NO CLAIM IS MADE TO THE EXCLUSIVE RIGHT TO USE "TRUFFLE", "TRUFFLES", "TOMATOES AND TRUFFLES", "MARCA DI FABBRICA", "ESPOSIZIONE INTERNAZIONALE TORINO 1911", "PARIGI 1910", "ESPOS. INTERNAZIONALE IN ROMA 1912 TORINO 1911" AND THE DEPICTION OF THE TOMATOES AND TRUFFLE, APART FROM THE MARK AS SHOWN.

THE NAMES "VITTORIO EMANUELE" AND "PAOLO URBANI" DO NOT IDENTIFY LIVING INDIVIDUALS.

THE COLOR(S) RED, BLACK, WHITE, GREEN AND GREY IS/ARE CLAIMED AS A FEATURE OF THE MARK.

THE MARK CONSISTS OF THE STYLIZED, BLACK WORDING "URBANI" APPEARING ABOVE THE STYLIZED, BLACK WORDING "TRUFFLES". IN BETWEEN THE WORDING "URBANI" AND "TRUFFLES" IS THE DEPICTION OF TWO GROUPS OF THREE BLACK AND WHITE COINS SEPARATED BY A CIRCLE CONTAINING THE BLACK AND WHITE DEPICTION OF A FARMER WORKING THE FIELDS WITH A DOG IN FRONT OF TICKET OF TREES. LOCATED BELOW THE FARMER AND DOG IN THE FIELD IS A WHITE BANNER CONTAINING THE BLACK WORDING "MARCA DI FABBRICA". THE THREE COINS APPEARING TO THE LEFT OF THE FARMER AND DOG IN THE FIELD ARE ARRANGED IN A TRIANGLE. THE LEFT MOST COIN COMPRISES THE BUST OF A HEAD WITH THE WORDING "VITTORIO EMANUELE ILL RE D'ITALIA", TO THE RIGHT OF THIS COIN APPEARS ANOTHER COIN CONTAINING THE

CLASS 30—(Continued).

DEPICTION OF A WREATH WITH THE WORDING "ESPOS. INTERNAZIONALE IN ROMA 1912 TORINO 1911" BELOW THAT COIN IS ANOTHER COIN CONTAINING THE DEPICTION OF NON-DESCRIPT PERSON SITTING IN FRONT OF BUILDING. THE THREE COINS APPEARING TO THE RIGHT OF THE FARMER AND DOG IN THE FIELD ARE ALSO ARRANGED IN A TRIANGLE. THE RIGHTMOST COIN COMPRISES THE BUST OF A HEAD, TO THE LEFT OF THIS COIN APPEARS ANOTHER COIN CONTAINING THE CIRCULAR WORDING "ESPOSIZIONE INTERNAZIONALE TORINO 1911" SURROUNDING THE WORDING "A PAOLO URBANI" BELOW THIS COIN APPEARS ANOTHER COIN CONTAINING THE DEPICTION OF A WREATH AND BANNER INSIDE WHICH IS THE WORDING "PARIGI 1911". THE COINS, WORDING IN THE COINS AS WELL AS THE IMAGES IN THE COINS ARE IN THE COLORS BLACK AND WHITE. BELOW THE BLACK WORDING "TRUFFLES" IS A RED RECTANGULAR BAND CONTAINING THE WHITE WORDING "TOMATOES AND TRUFFLES". BELOW THE RED BAND IS THE DEPICTION OF FOUR RED TOMATOES HAVING WHITE AND GREY SHADING CONNECTED TO A GREEN STEM LOCATED ABOVE THE DEPICTION OF A BLACK TRUFFLE. TO THE LEFT OF THE DEPICTION OF THE TOMATOES AND TRUFFLE IS THE STYLIZED, BLACK WORDING "TRUFFLE THRILLS" WITH A BLACK UNDERLINE ARRANGED VERTICALLY FROM THE BOTTOM. OTHER THAN THE COLOR WHITE APPEARING IN THE DEPICTION OF THE COINS, THE DEPICTION OF THE FARMER AND DOG IN THE FIELD, THE SHADING ON THE TOMATOES AND THE WORDING "TOMATOES AND TRUFFLES" THE COLOR WHITE REPRESENTS BACKGROUND OR TRANSPARENT AREAS OF THE MARK AND IS NOT PART OF THE MARK.

THE ENGLISH TRANSLATION OF "URBANI" IS "CITIZENS OF THE TOWN"; THE ENGLISH TRANSLATION OF "ESPOSIZIONE INTERNAZIONALE TORINO 1911 A PAOLO URBANI" IS "INTERNATIONAL EXHIBITION TURIN 1911 TO PAOLO URBANI"; THE ENGLISH TRANSLATION OF "PARIGI 1910" IS "PARIS 1910"; THE ENGLISH TRANSLATION OF "MARCA DI FABBRICA" IS "BRAND OR "TRADEMARK"; THE ENGLISH TRANSLATION OF "VITTORIO EMANUELE III RE D'ITALIA" IS "VITTORIO EMANUELE THE THIRD KING OF ITALY"; THE ENGLISH TRANSLATION OF "ESPOS. INTERNAZIONALE IN ROMA 1912 TORINO 1911" IS "INTERNATIONAL EXHIBITION IN ROME 1912 TURIN 1911".

FOR SAUCES AND SALAD DRESSINGS CONTAINING TOMATO AND TRUFFLES (U.S. CL. 46).

FIRST USE 11-30-2009; IN COMMERCE 11-30-2009.

MICHAEL TANNER, EXAMINING ATTORNEY

CLASS 30—(Continued).

SN 85-322,039. URBANI TARTUFI S.R.L., PERUGIA, ITALY, FILED 5-16-2011.



OWNER OF U.S. REG. NOS. 2,977,165, 3,995,978 AND OTHERS.

NO CLAIM IS MADE TO THE EXCLUSIVE RIGHT TO USE "TRUFFLE", "TRUFFLES", "WHITE TRUFFLES AND MUSHROOMS", "MARCA DI FABBRICA", "ESPOSIZIONE INTERNAZIONALE TORINO 1911", "PARIGI 1910", "ESPOS. INTERNAZIONALE IN ROMA 1912 TORINO 1911" AND THE DEPICTION OF THE TWO MUSHROOMS AND TRUFFLE, APART FROM THE MARK AS SHOWN.

THE NAMES "VITTORIO EMANUELE" AND "PAOLO URBANI" DO NOT IDENTIFY LIVING INDIVIDUALS.

THE COLOR(S) TAN, BLACK, BROWN, WHITE AND GREY IS/ARE CLAIMED AS A FEATURE OF THE MARK.

THE MARK CONSISTS OF THE STYLIZED, BLACK WORDING "URBANI" APPEARING ABOVE THE STYLIZED, BLACK WORDING "TRUFFLES". IN BETWEEN THE WORDING "URBANI" AND "TRUFFLES" IS THE DEPICTION OF TWO GROUPS OF THREE BLACK AND WHITE COINS SEPARATED BY A CIRCLE CONTAINING THE BLACK AND WHITE DEPICTION OF A FARMER WORKING THE FIELDS WITH A DOG IN FRONT OF TICKET OF TREES. LOCATED BELOW THE FARMER AND DOG IN THE FIELD IS A WHITE BANNER CONTAINING THE BLACK WORDING "MARCA DI FABBRICA". THE THREE COINS APPEARING TO THE LEFT OF THE FARMER AND DOG IN THE FIELD ARE ARRANGED IN A TRIANGLE. THE LEFT MOST COIN COMPRISES THE BUST OF A HEAD WITH THE WORDING "VITTORIO EMANUELE III RE D'ITALIA", TO THE RIGHT OF THIS COIN APPEARS ANOTHER COIN CONTAINING THE DEPICTION OF A WREATH WITH THE WORDING "ESPOS. INTERNAZIONALE IN ROMA 1912 TORINO 1911" BELOW THAT COIN IS ANOTHER COIN CONTAINING THE DEPICTION OF NON-DESCRIPT PERSON SITTING IN FRONT OF BUILDING. THE THREE COINS APPEARING TO THE RIGHT OF THE FARMER AND DOG IN THE FIELD ARE ALSO ARRANGED IN A TRIANGLE. THE RIGHTMOST COIN COMPRISES THE BUST OF A HEAD, TO THE LEFT OF THIS COIN APPEARS ANOTHER COIN CONTAINING THE CIRCULAR WORDING "ESPOSIZIONE INTERNAZIONALE TORINO 1911" SURROUNDING THE WORDING "A PAOLO URBANI" BELOW THIS COIN APPEARS ANOTHER COIN CONTAINING THE DEPICTION OF A WREATH AND BANNER INSIDE WHICH IS THE WORDING "PARIGI 1911". THE COINS, WORDING IN THE COINS AS WELL AS THE IMAGES IN THE COINS ARE IN THE COLORS BLACK AND WHITE. BELOW THE BLACK WORDING "TRUFFLES" IS A TAN RECTANGULAR BAND CONTAINING THE WHITE WORDING "WHITE TRUFFLES AND MUSHROOMS". BELOW THE TAN BAND IS THE DEPICTION OF A TWO TAN, WHITE AND GREY MUSHROOMS LOCATED ABOVE THE DEPICTION OF A TAN AND BROWN TRUFFLE WITH GREY AND BLACK SHADING. TO THE LEFT OF THE DEPICTION OF THE TWO MUSHROOMS AND TRUFFLE IS THE

CLASS 30—(Continued).

STYLIZED, BLACK WORDING "TRUFFLE THRILLS" WITH A BLACK UNDERLINE ARRANGED VERTICALLY FROM THE BOTTOM. OTHER THAN THE COLOR WHITE APPEARING IN THE DEPICTION OF THE COINS, THE DEPICTION OF THE MUSHROOMS, THE DEPICTION OF THE FARMER AND DOG IN THE FIELD, AND THE WORDING "WHITE TRUFFLES AND MUSHROOMS" THE COLOR WHITE REPRESENTS BACKGROUND OR TRANSPARENT AREAS OF THE MARK AND IS NOT PART OF THE MARK.

THE ENGLISH TRANSLATION OF "URBANI" IS "CITIZENS OF THE TOWN"; THE ENGLISH TRANSLATION OF "ESPOSIZIONE INTERNAZIONALE TORINO 1911 A PAOLO URBANI" IS "INTERNATIONAL EXHIBITION TURIN 1911 TO PAOLO URBANI"; THE ENGLISH TRANSLATION OF "PARIGI 1910" IS "PARIS 1910"; THE ENGLISH TRANSLATION OF "MARCA DI FABBRICA" IS "BRAND OR "TRADEMARK"; THE ENGLISH TRANSLATION OF "VITTORIO EMANUELE III RE D'ITALIA" IS "VITTORIO EMANUELE THE THIRD KING OF ITALY"; THE ENGLISH TRANSLATION OF "ESPOS. INTERNAZIONALE IN ROMA 1912 TORINO 1911" IS "INTERNATIONAL EXHIBITION IN ROME 1912 TURIN 1911".

FOR SAUCES AND SALAD DRESSINGS CONTAINING WHITE TRUFFLES AND MUSHROOMS (U.S. CL. 46).

FIRST USE 11-30-2009; IN COMMERCE 11-30-2009.
MICHAEL TANNER, EXAMINING ATTORNEY

SN 85-322,061. URBANI TARTUFI S.R.L., PERUGIA, ITALY,
FILED 5-16-2011.



OWNER OF U.S. REG. NOS. 2,977,165, 3,995,978 AND OTHERS.

NO CLAIM IS MADE TO THE EXCLUSIVE RIGHT TO USE "TRUFFLE", TRUFFLES", "WHITE TRUFFLES AND PORCINI", "MARCA DI FABBRICA", "ESPOSIZIONE INTERNAZIONALE TORINO 1911", "PARIGI 1910", "ESPOS. INTERNAZIONALE IN ROMA 1912 TORINO 1911" AND THE DEPICTION OF THE PORCINI MUSHROOM AND TRUFFLE, APART FROM THE MARK AS SHOWN.

THE NAMES "VITTORIO EMANUELE" AND "PAOLO URBANI" DO NOT IDENTIFY LIVING INDIVIDUALS.

THE COLOR(S) TAN, BLACK, BROWN, WHITE AND GREY IS/ARE CLAIMED AS A FEATURE OF THE MARK.

THE MARK CONSISTS OF THE STYLIZED, BLACK WORDING "URBANI" APPEARING ABOVE THE STYLIZED, BLACK WORDING "TRUFFLES". IN BETWEEN THE WORDING "URBANI" AND "TRUFFLES" IS THE DEPICTION OF TWO GROUPS OF THREE BLACK AND WHITE COINS SEPARATED BY A CIRCLE CONTAINING THE BLACK AND WHITE DEPICTION OF A FARMER WORKING THE FIELDS WITH A DOG IN FRONT OF TICKET OF TREES. LOCATED BELOW THE FARMER AND DOG IN THE FIELD IS A WHITE BANNER CONTAINING THE BLACK WORDING "MARCA DI FABBRICA". THE THREE COINS APPEARING TO THE LEFT OF THE FARMER AND DOG IN THE FIELD ARE ARRANGED IN A TRIANGLE. THE LEFT MOST COIN COMPRISES THE BUST OF A HEAD WITH THE WORDING "VITTORIO EMANUELE III RE D'ITALIA", TO THE RIGHT OF THIS

CLASS 30—(Continued).

COIN APPEARS ANOTHER COIN CONTAINING THE DEPICTION OF A WREATH WITH THE WORDING "ESPOS. INTERNAZIONALE IN ROMA 1912 TORINO 1911" BELOW THAT COIN IS ANOTHER COIN CONTAINING THE DEPICTION OF NON-DESCRIPT PERSON SITTING IN FRONT OF BUILDING. THE THREE COINS APPEARING TO THE RIGHT OF THE FARMER AND DOG IN THE FIELD ARE ALSO ARRANGED IN A TRIANGLE. THE RIGHTMOST COIN COMPRISES THE BUST OF A HEAD, TO THE LEFT OF THIS COIN APPEARS ANOTHER COIN CONTAINING THE CIRCULAR WORDING "ESPOSIZIONE INTERNAZIONALE TORINO 1911" SURROUNDING THE WORDING "A PAOLO URBANI" BELOW THIS COIN APPEARS ANOTHER COIN CONTAINING THE DEPICTION OF A WREATH AND BANNER INSIDE WHICH IS THE WORDING "PARIGI 1911". THE COINS, WORDING IN THE COINS AS WELL AS THE IMAGES IN THE COINS ARE IN THE COLORS BLACK AND WHITE. BELOW THE BLACK WORDING "TRUFFLES" IS A BROWN RECTANGULAR BAND CONTAINING THE WHITE WORDING "WHITE TRUFFLES AND PORCINI". BELOW THE TAN BAND IS THE DEPICTION OF A BROWN AND TAN PORCINI MUSHROOM WITH WHITE, BLACK AND GREY SHADING LOCATED ABOVE THE DEPICTION OF A TAN AND BROWN TRUFFLE WITH GREY AND BLACK SHADING. TO THE LEFT OF THE DEPICTION OF THE MUSHROOM AND TRUFFLE IS THE STYLIZED, BLACK WORDING "TRUFFLE THRILLS" WITH A BLACK UNDERLINE ARRANGED VERTICALLY FROM THE BOTTOM. OTHER THAN THE COLOR WHITE APPEARING IN THE DEPICTION OF THE COINS, THE DEPICTION OF THE MUSHROOM, THE DEPICTION OF THE FARMER AND DOG IN THE FIELD, AND THE WORDING "WHITE TRUFFLES AND MUSHROOMS" THE COLOR WHITE REPRESENTS BACKGROUND OR TRANSPARENT AREAS OF THE MARK AND IS NOT PART OF THE MARK.

THE ENGLISH TRANSLATION OF "URBANI" IS "CITIZENS OF THE TOWN"; THE ENGLISH TRANSLATION OF "ESPOSIZIONE INTERNAZIONALE TORINO 1911 A PAOLO URBANI" IS "INTERNATIONAL EXHIBITION TURIN 1911 TO PAOLO URBANI"; THE ENGLISH TRANSLATION OF "PARIGI 1910" IS "PARIS 1910"; THE ENGLISH TRANSLATION OF "MARCA DI FABBRICA" IS "BRAND" OR "TRADEMARK"; THE ENGLISH TRANSLATION OF "VITTORIO EMANUELE III RE D'ITALIA" IS "VITTORIO EMANUELE THE THIRD KING OF ITALY"; THE ENGLISH TRANSLATION OF "ESPOS. INTERNAZIONALE IN ROMA 1912 TORINO 1911" IS "INTERNATIONAL EXHIBITION IN ROME 1912 TURIN 1911".

FOR SAUCES AND SALAD DRESSINGS CONTAINING WHITE TRUFFLES AND PORCINI MUSHROOMS (U.S. CL. 46).

FIRST USE 11-30-2009; IN COMMERCE 11-30-2009.
MICHAEL TANNER, EXAMINING ATTORNEY

SN 85-332,887. LA TAPATIA TORTILLERIA, INC., FRESNO,
CA. FILED 5-27-2011.

EL CABALLERO

THE MARK CONSISTS OF STANDARD CHARACTERS WITHOUT CLAIM TO ANY PARTICULAR FONT, STYLE, SIZE, OR COLOR.

THE ENGLISH TRANSLATION OF THE MARK IS "THE GENTLEMAN".

FOR CORN AND FLOUR TORTILLAS, CORN TOSTADAS (U.S. CL. 46).

ELLEN PERKINS, EXAMINING ATTORNEY

CLASS 30—(Continued).

SN 85-343,791. BRADFIELD, RICHARD, BOULDER, CO.
FILED 6-10-2011.

Nova Monda Cacao

THE MARK CONSISTS OF STANDARD CHARACTERS WITHOUT CLAIM TO ANY PARTICULAR FONT, STYLE, SIZE, OR COLOR.

NO CLAIM IS MADE TO THE EXCLUSIVE RIGHT TO USE "CACAO", APART FROM THE MARK AS SHOWN.

FOR CANDY (U.S. CL. 46).
MARCIE MILONE, EXAMINING ATTORNEY

SN 85-348,045. OROGRAIN BAKERIES PRODUCTS, INC.,
HORSHAM, PA. FILED 6-16-2011.

ENTENMANN'S LITTLE BITES

THE MARK CONSISTS OF STANDARD CHARACTERS WITHOUT CLAIM TO ANY PARTICULAR FONT, STYLE, SIZE, OR COLOR.

OWNER OF U.S. REG. NOS. 1,152,585, 3,830,163 AND OTHERS.

SEC. 2(F) AS TO "LITTLE BITES".
FOR BROWNIES AND MUFFINS (U.S. CL. 46).
FIRST USE 4-30-1999; IN COMMERCE 4-30-1999.
TIMOTHY FINNEGAN, EXAMINING ATTORNEY

SN 85-353,602. YOGURTKING LLC, DBA BOBAKING,
DALLAS, TX. FILED 6-22-2011.



THE COLOR(S) LIME GREEN, GREEN, ORANGE, RED AND GOLD IS/ARE CLAIMED AS A FEATURE OF THE MARK.

THE MARK CONSISTS OF THE STYLIZED WORD "BOBAKING"; THE WORD "BOBA" IS IN LIME GREEN AND OUTLINED IN GREEN; THE LETTERS "K" AND "N" ARE IN ORANGE; THE LETTERS "I" AND "G" ARE IN RED. THE LETTER "I" IS TILTED 20 DEGREES TO RIGHT AND THE LETTER "N" IS TILTED 20 DEGREES TO THE LEFT. A THREE POINTED CROWN IN LIME GREEN AND OUTLINED IN GREEN WITH GOLD CIRCLES AT THE POINTS IS POSITIONED ON THE LETTER "G" AND TILTED 20 DEGREES TO THE RIGHT OF CENTER.

THE WORDING "BOBAKING" HAS NO MEANING IN A FOREIGN LANGUAGE.

FOR BEVERAGES MADE OF TEA; BEVERAGES WITH A TEA BASE; COFFEE AND TEA; GINSENG TEA; GREEN TEA; HERB TEA; ICED TEA; LIME TEA; TEA-BASED BEVERAGES; TEA-BASED BEVERAGES WITH FRUIT FLAVORING (U.S. CL. 46).

JULIE GUTTADAURO, EXAMINING ATTORNEY

CLASS 30—(Continued).

SN 85-361,587. DONG WHA PHARM CO., LTD, SEOUL,
REPUBLIC OF KOREA, FILED 7-1-2011.

Whal Myung Su

THE MARK CONSISTS OF STANDARD CHARACTERS WITHOUT CLAIM TO ANY PARTICULAR FONT, STYLE, SIZE, OR COLOR.

OWNER OF U.S. REG. NO. 2,985,021.
THE WORDING "WHAL MYUNG SU" HAS NO MEANING IN A FOREIGN LANGUAGE.
FOR HERBAL FOOD BEVERAGE (U.S. CL. 46).
DAWN FELDMAN, EXAMINING ATTORNEY

SN 85-361,813. RUDY GUERRINO, MOUNT VERNON, NY.
FILED 7-1-2011.

Taste the Islands

THE MARK CONSISTS OF STANDARD CHARACTERS WITHOUT CLAIM TO ANY PARTICULAR FONT, STYLE, SIZE, OR COLOR.

FOR ICE CREAM (U.S. CL. 46).
MARK SPARACINO, EXAMINING ATTORNEY

SN 85-366,704. FABRICA ESPECIAS DON JULIO, S. DE R. L.,
S. PEDRO SULA, HONDURAS, FILED 7-8-2011.

ESPECIAS DON JULIO

THE MARK CONSISTS OF STANDARD CHARACTERS WITHOUT CLAIM TO ANY PARTICULAR FONT, STYLE, SIZE, OR COLOR.

OWNER OF HONDURAS REG. NO. 48879, DATED 2-3-1988, EXPIRES 3-2-2018.

NO CLAIM IS MADE TO THE EXCLUSIVE RIGHT TO USE "ESPECIAS", APART FROM THE MARK AS SHOWN.

THE NAME "DON JULIO" DOES NOT IDENTIFY A LIVING INDIVIDUAL.

THE ENGLISH TRANSLATION OF "ESPECIAS" IS "SPICES" AND "DON JULIO" IS "SIR JULIO."

FOR COFFEE, TEA, COCOA, SUGAR, TAPIOCA, SAGU, RICE, ARTIFICIAL COFFEE, FLOUR AND PREPARATIONS MADE FROM CEREALS, BREAD, BISCUITS, CAKES, PASTRY AND CONFECTIONERY, ICE CREAM, HONEY, SYRUP OF MOLASSES, YEAST, BAKING POWDER, SALT, MUSTARD, VINEGAR, SAUCES-(CONDIMENTS); SAUCES, SPICES, ICE, POP CORN, CUSTARD (U.S. CL. 46).

FIRST USE 6-1-2004; IN COMMERCE 10-20-2004.
JOHN WILKE, EXAMINING ATTORNEY

CLASS 30—(Continued).

SN 85-371,155. E.A. SWEEN COMPANY, EDEN PRAIRIE, MN. FILED 7-14-2011.



THE COLOR(S) GREEN, CREAM, LIGHT GREY, DARK GREY, AND BLACK IS/ARE CLAIMED AS A FEATURE OF THE MARK.

THE MARK CONSISTS OF THREE CONCENTRIC CIRCLES WHERE IN THE SECOND CIRCLE HAS A SCALLOPED BORDER AND WITH TWO SMALLER CIRCLES APPEARING ON THE RIGHT AND LEFT SIDE OF THE MOST INNER CIRCLE TO THE LEFT AND RIGHT OF THE STYLIZED TERM "MS", WHICH APPEARS IN THE CENTER; THE COLOR GREEN APPEARS IN THE OUTERMOST CIRCLE; THE COLOR CREAM APPEARS IN THE CENTER CIRCLE AND IN THE TWO SMALL CIRCLES TO THE LEFT AND RIGHT OF THE STYLIZED TERM "MS"; THE COLORS LIGHT GREY AND DARK GREY APPEAR IN THE SHADING AROUND THE INNERMOST CIRCLE; THE COLOR BLACK APPEARS IN THE CENTER CONCENTRIC CIRCLE WITH THE SCALLOPED BORDER AND IN THE TERM "MS"

FOR SANDWICHES (U.S. CL. 46).
FIRST USE 4-25-2011; IN COMMERCE 4-25-2011.
MYRIAH HABEEB, EXAMINING ATTORNEY

SN 85-371,675. THE JEL SERT CO., WEST CHICAGO, IL, IL. FILED 7-14-2011.

BOLIS

THE MARK CONSISTS OF STANDARD CHARACTERS WITHOUT CLAIM TO ANY PARTICULAR FONT, STYLE, SIZE, OR COLOR.

OWNER OF U.S. REG. NO. 1,875,439.
FOR DESSERTS, NAMELY, PUDDING, CHOCOLATE-BASED PIE FILLINGS, CUSTARD-BASED PIE FILLINGS, CHEESECAKES, FLAN AND ATOLE, NAMELY, CORN STARCH BASED DRINK, IN THE NATURE OF A FOOD BEVERAGE CONSISTING PRIMARILY OF MAIZE AND PORRIDGE; POWDERED MIXES FOR DESSERTS, NAMELY, PUDDING, CHOCOLATE-BASED PIE FILLINGS, CUSTARD-BASED PIE FILLINGS, CHEESECAKES, FLAN AND ATOLE, NAMELY, CORN STARCH BASED DRINK, IN THE NATURE OF A FOOD BEVERAGE CONSISTING PRIMARILY OF MAIZE AND PORRIDGE (U.S. CL. 46).

ELI HELLMAN, EXAMINING ATTORNEY

CLASS 30—(Continued).

SN 85-373,932. PANDURATA ALIMENTOS LTDA., GUARULHOS - SAO PAULO, BRAZIL, FILED 7-18-2011.



THE MARK CONSISTS OF THE TERM "VISCONTI" ON A RIBBON BORDER DESIGN WITH A STAR BURST PATTERN UNDER THE LETTER "V" IN THE TERM "VISCONTI".

THE WORDING "VISCONTI" HAS NO MEANING IN A FOREIGN LANGUAGE.

FOR CRACKERS, SALTINES, COOKIES, BUTTER COOKIES, CREAM CRACKER, CHAMPAGNE BISCUIT, WAFERS, CAKES, TOASTS AND PANETTONES (U.S. CL. 46).

JOHN DALIER, EXAMINING ATTORNEY

SN 85-379,800. S. ABRAHAM & SONS, INC., WALKER, MI. FILED 7-25-2011.

FRUIT RIDGE FARMS

THE MARK CONSISTS OF STANDARD CHARACTERS WITHOUT CLAIM TO ANY PARTICULAR FONT, STYLE, SIZE, OR COLOR.

NO CLAIM IS MADE TO THE EXCLUSIVE RIGHT TO USE "FARMS", APART FROM THE MARK AS SHOWN.

FOR PASTRIES, CAKES, PIES, MUFFINS, BREADS, CINNAMON ROLLS, AND DESSERTS (U.S. CL. 46).
KATINA MISTER, EXAMINING ATTORNEY

SN 85-379,806. S. ABRAHAM & SONS, INC., WALKER, MI. FILED 7-25-2011.



NO CLAIM IS MADE TO THE EXCLUSIVE RIGHT TO USE "FARMS" AND "QUALITY" AND "FRESH", APART FROM THE MARK AS SHOWN.

THE MARK CONSISTS OF AN OVAL CONTAINING A DESIGN OF FARM FIELDS WITH A BARN AND A BUSHEL BASKET AT THE FOREFRONT CONTAINING VEGETABLES AND FRUIT; AT THE TOP OF THE OVAL IS THE WORDS "FRUIT RIDGE FARMS"; AT THE BOTTOM THE TERM "QUALITY FRESH" SEPARATED BY A SMALL FLOWER.

FOR PASTRIES, CAKES, PIES, MUFFINS, BREADS, CINNAMON ROLLS, AND DESSERTS (U.S. CL. 46).
KATINA MISTER, EXAMINING ATTORNEY

CLASS 30—(Continued).

SN 85-380,400. MAKANA BEVERAGES INC., HALEIWA, HI.
FILED 7-25-2011.

TheBU Kombucha

THE MARK CONSISTS OF STANDARD CHARACTERS WITHOUT CLAIM TO ANY PARTICULAR FONT, STYLE, SIZE, OR COLOR.

NO CLAIM IS MADE TO THE EXCLUSIVE RIGHT TO USE "KOMBUCHA", APART FROM THE MARK AS SHOWN.

FOR BEVERAGES WITH A TEA BASE (U.S. CL. 46).
FIRST USE 7-1-2010; IN COMMERCE 7-1-2010.
DAWN FELDMAN, EXAMINING ATTORNEY

CLASS 30—(Continued).

SN 85-418,056. IVAN CHIN, SINGAPORE, SINGAPORE,
FILED 9-8-2011.

ZING KU

THE MARK CONSISTS OF STANDARD CHARACTERS WITHOUT CLAIM TO ANY PARTICULAR FONT, STYLE, SIZE, OR COLOR.

FOR HERBAL FOOD BEVERAGES (U.S. CL. 46).
TIMOTHY FINNEGAN, EXAMINING ATTORNEY

SN 85-413,375. HOMESTEAD DISTRIBUTIONS LLC, SAINT
GEORGE, UT. FILED 9-1-2011.

Purely Organic

THE MARK CONSISTS OF STANDARD CHARACTERS WITHOUT CLAIM TO ANY PARTICULAR FONT, STYLE, SIZE, OR COLOR.

NO CLAIM IS MADE TO THE EXCLUSIVE RIGHT TO USE "ORGANIC", APART FROM THE MARK AS SHOWN.

FOR ORGANIC SEASONINGS (U.S. CL. 46).
FIRST USE 5-16-2011; IN COMMERCE 8-31-2011.
LINDA M. KING, EXAMINING ATTORNEY

SN 85-414,177. FREDERICK'S PASTRIES, LLC, AMHERST,
NH. FILED 9-2-2011.



NO CLAIM IS MADE TO THE EXCLUSIVE RIGHT TO USE "PASTRIES", APART FROM THE MARK AS SHOWN.

THE MARK CONSISTS OF A FORWARD FACING CARICATURE OF A MAN HAVING A MOUSTACHE AND A BANDANA AROUND HIS NECK AND WEARING A CHEF'S HAT, ALONGSIDE THE WORDS "FREDERICK'S PASTRIES".

FOR BAKERY DESSERTS; BAKERY GOODS; CAKES;
CUP CAKES; PASTRIES (U.S. CL. 46).
FIRST USE 1-1-1981; IN COMMERCE 1-1-1981.
CHARLOTTE CORWIN, EXAMINING ATTORNEY

SN 85-422,956. PANOS BRANDS, L.L.C., SADDLE BROOK,
NJ. FILED 9-14-2011.



OWNER OF U.S. REG. NOS. 1,952,904 AND 8,527,673.
NO CLAIM IS MADE TO THE EXCLUSIVE RIGHT TO USE "GINGERBREAD MEN" AND THE PICTORIAL REPRESENTATION OF COOKIES IN THE SHAPE OF GINGERBREAD MEN, APART FROM THE MARK AS SHOWN.

THE COLOR(S) WHITE, BLUE, LIGHT BLUE, RED, BROWN AND BLACK IS/ARE CLAIMED AS A FEATURE OF THE MARK.

THE MARK CONSISTS OF THE TERM, "MI-DEL" IN WHITE OUTLINED IN BLACK AND THEN RED AND INSIDE A LARGE SHADED LIGHT BLUE RECTANGLE OUTLINED IN RED, ABOVE THE TERMS, "GINGERBREAD MEN" IN WHITE INSIDE TWO RED SHADED CONCENTRIC RECTANGLES WITH A WHITE BORDER AROUND THE INSIDE RECTANGLE ALL LOCATED WITHIN THE SAME LIGHT BLUE RECTANGLE DESIGN AS THE TERM, "MI-DEL"; SURROUNDING THE WORDING AND CONCENTRIC RECTANGLE DESIGN ARE FIVE BROWN GINGERBREAD MEN COOKIES SPRINKLED WITH WHITE SUGAR, WITH THE DESIGN OF SEVEN BLUE SNOWFLAKES IN VARIOUS DESIGNS AND SIZES SHOWN ABOVE AND TO THE LEFT OF THE RECTANGLE DESIGN, AND SUPERIMPOSED OVER AND SURROUNDING THE LOWER RIGHT CORNER OF A PARTIAL SHADED LIGHT BLUE RECTANGLE OUTLINED IN RED; THE UPPER RIGHT CORNER OF A THIRD LIGHT BLUE RECTANGLE OUTLINED IN RED IS SHOWN TO THE LEFT AND BELOW THE CENTER RECTANGLE CONTAINING THE WORDING.

FOR COOKIES (U.S. CL. 46).
BARBARA A. GOLD, EXAMINING ATTORNEY

CLASS 30—(Continued).

SN 85-426,627. NATURE'S PRODUCTS LTD, PALO ALTO, CA. FILED 9-20-2011.

MYSTEVIA

THE MARK CONSISTS OF STANDARD CHARACTERS WITHOUT CLAIM TO ANY PARTICULAR FONT, STYLE, SIZE, OR COLOR.
FOR NATURAL SWEETENERS MADE IN SIGNIFICANT PART OF STEVIA (U.S. CL. 46).
LAURIE KAUFMAN, EXAMINING ATTORNEY

SN 85-429,486. NUNATURALS, INC., EUGENE, OR. FILED 9-22-2011.

Sweet Health

THE MARK CONSISTS OF STANDARD CHARACTERS WITHOUT CLAIM TO ANY PARTICULAR FONT, STYLE, SIZE, OR COLOR.
NO CLAIM IS MADE TO THE EXCLUSIVE RIGHT TO USE "SWEET", APART FROM THE MARK AS SHOWN.
FOR NATURAL SWEETENER (U.S. CL. 46).
FIRST USE 12-0-2001; IN COMMERCE 12-0-2001.
ALLISON HOLTZ, EXAMINING ATTORNEY

SN 85-430,114. KOHR BROTHERS, INC., CHARLOTTESVILLE, VA. FILED 9-23-2011.

CONEY ISLAND BOARDWALK CUSTARD

THE MARK CONSISTS OF STANDARD CHARACTERS WITHOUT CLAIM TO ANY PARTICULAR FONT, STYLE, SIZE, OR COLOR.
NO CLAIM IS MADE TO THE EXCLUSIVE RIGHT TO USE "CONEY ISLAND" AND "CUSTARD", APART FROM THE MARK AS SHOWN.
FOR FROZEN DESSERTS, NAMELY, FROZEN CUSTARDS (U.S. CL. 46).
JOHN DWYER, EXAMINING ATTORNEY

CLASS 30—(Continued).

SN 85-430,190. COLLINS, RICHARD D., MINEOLA, NY. FILED 9-23-2011.

PRONUTS

THE MARK CONSISTS OF STANDARD CHARACTERS WITHOUT CLAIM TO ANY PARTICULAR FONT, STYLE, SIZE, OR COLOR.
FOR DONUTS (U.S. CL. 46).
DAWN HAN, EXAMINING ATTORNEY

SN 85-430,819. SCHEPERS, MICHAEL, IRVINE, CA. FILED 9-23-2011.

THE KARMA BURGER

THE MARK CONSISTS OF STANDARD CHARACTERS WITHOUT CLAIM TO ANY PARTICULAR FONT, STYLE, SIZE, OR COLOR.
NO CLAIM IS MADE TO THE EXCLUSIVE RIGHT TO USE "BURGER", APART FROM THE MARK AS SHOWN.
FOR SANDWICHES, NAMELY, HAMBURGERS, CHEESEBURGERS (U.S. CL. 46).
FIRST USE 11-0-2010; IN COMMERCE 11-0-2010.
DAVID MURRAY, EXAMINING ATTORNEY

SN 85-433,575. KIKKOMAN CORPORATION, NODA CITY, CHIBA, JAPAN, FILED 9-27-2011.



OWNER OF U.S. REG. NOS. 1,138,991, 3,627,061 AND OTHERS.
THE MARK CONSISTS OF A CHINESE CHARACTER TRANSLITERATED AS MAN AND MEANING TEN THOUSAND IN A HEXAGON AT THE TOP CENTER OF A CIRCLE DESIGN AND POSITIONED IN THE MIDDLE OF A HORIZONTAL BANNER THAT IS COVERING THE TOP

CLASS 30—(Continued).

PORTION OF THE CIRCLE DESIGN, WITH THE CIRCLE DESIGN COMPRISED OF TWO CONCENTRIC CIRCLES CREATING A LARGE CENTRAL SPACE WITHIN THE INNER CIRCLE, AND A NARROW CIRCULAR SPACE BETWEEN THE INNER AND OUTER CIRCLES, AND WITH THE SAID NARROW CIRCULAR SPACE FILLED IN SYMMETRICALLY WITH SMALL HEXAGONAL SHAPES COVERING ALL OF THE UPPER PORTION AND ABOUT ONE-THIRD OF THE LOWER PORTION OF THE NARROW CIRCULAR SPACE ON EITHER SIDE.

THE ENGLISH TRANSLATION OF THE CHINESE CHARACTER IN THE MARK IS TEN THOUSAND.

THE NON-LATIN CHARACTERS IN THE MARK TRANSLITERATE TO MAN AND THIS MEANS TEN THOUSAND IN ENGLISH.

FOR SEASONINGS: SEASONINGS, NAMELY, SOY SAUCE, WORCESTERSHIRE SAUCE, TERIYAKI SAUCE, HOT CHILI SAUCE, WASABI SAUCE, SWEET SOY GLAZE, KETCHUP, VINEGAR, VINEGAR MIXES, SALAD DRESSING, WHITE SAUCE, MAYONNAISE (U.S. CL. 46).

DEZMONA MIZELLE, EXAMINING ATTORNEY

SN 85-437,478. URBAN BELLY, LLC, CHICAGO, IL. FILED S.R. 10-3-2011; AM. P.R. 10-11-2011.

SEOUL SAUCE

THE MARK CONSISTS OF STANDARD CHARACTERS WITHOUT CLAIM TO ANY PARTICULAR FONT, STYLE, SIZE, OR COLOR.

NO CLAIM IS MADE TO THE EXCLUSIVE RIGHT TO USE "SAUCE", APART FROM THE MARK AS SHOWN.

FOR SOY SAUCE (U.S. CL. 46).

FIRST USE 1-1-2011; IN COMMERCE 1-1-2011.

KELLY BOULTON, EXAMINING ATTORNEY

SN 85-440,610. GRUPO BIMBO, S.A. B. DE C.V., PROLONGACION PASEO DE, MEXICO, FILED 10-6-2011.

BOMBA SANDIA

THE MARK CONSISTS OF STANDARD CHARACTERS WITHOUT CLAIM TO ANY PARTICULAR FONT, STYLE, SIZE, OR COLOR.

NO CLAIM IS MADE TO THE EXCLUSIVE RIGHT TO USE "SANDIA", APART FROM THE MARK AS SHOWN.

THE ENGLISH TRANSLATION OF "BOMBA SANDIA" IN THE MARK IS "WATERMELON BOMB".

FOR CANDY, NAMELY, LOLLIPOPS AND SUCKERS FROM CRYSTALLIZED SUGAR AND/OR CHOCOLATE (U.S. CL. 46).

MARGERÝ A. TIERNEY, EXAMINING ATTORNEY

CLASS 30—(Continued).

SN 85-443,987. GRUPO BIMBO, S.A. B. DE C.V., MEXICO CITY, MEXICO, FILED 10-11-2011.

SEMAFORITO

THE MARK CONSISTS OF STANDARD CHARACTERS WITHOUT CLAIM TO ANY PARTICULAR FONT, STYLE, SIZE, OR COLOR.

THE ENGLISH TRANSLATION OF "SEMAFORITO" IN THE MARK IS "LITTLE TRAFFIC LIGHT".

FOR CANDY, NAMELY, LOLLIPOPS AND SUCKERS FROM CRYSTALLIZED SUGAR AND/OR CHOCOLATE (U.S. CL. 46).

MARGERÝ A. TIERNEY, EXAMINING ATTORNEY

SN 85-445,263. GRUPO BIMBO, S.A. B. DE C.V., MEXICO CITY, MEXICO, FILED 10-12-2011.

PALERINDAS

THE MARK CONSISTS OF STANDARD CHARACTERS WITHOUT CLAIM TO ANY PARTICULAR FONT, STYLE, SIZE, OR COLOR.

THE WORDING "PALERINDAS" HAS NO MEANING IN A FOREIGN LANGUAGE.

FOR LOLLIPOPS AND SUCKERS FROM CRYSTALLIZED SUGAR AND/OR CHOCOLATE (U.S. CL. 46).

MARGERÝ A. TIERNEY, EXAMINING ATTORNEY

SN 85-445,533. CALVERT RETAIL, INC., MONTCHANIN, DE. FILED 10-12-2011.



THE MARK CONSISTS OF "LUVRUB". FOR SPICES, SPICE RUBS, SEASONINGS, BARBECUE SPICES, AND BARBECUE SEASONINGS (U.S. CL. 46).

FIRST USE 4-10-2000; IN COMMERCE 1-1-2001.

KIMBERLY PERRY, EXAMINING ATTORNEY

CLASS 30—(Continued).

SN 85-446,167. SUSHI TOKYO CI INC., BROOKLYN, NY.
FILED 10-13-2011.

YAMATO ROLL

THE MARK CONSISTS OF STANDARD CHARACTERS WITHOUT CLAIM TO ANY PARTICULAR FONT, STYLE, SIZE, OR COLOR.

NO CLAIM IS MADE TO THE EXCLUSIVE RIGHT TO USE "ROLL", APART FROM THE MARK AS SHOWN.

THE ENGLISH TRANSLATION OF "YAMATO" IN THE MARK IS "SOUL OF JAPAN" OR "THE JAPANESE SPIRIT".

FOR SUSHI (U.S. CL. 46).

FIRST USE 0-0-2008; IN COMMERCE 0-0-2008.
DEBORAH LOBO, EXAMINING ATTORNEY

CLASS 30—(Continued).

SN 85-446,297. THEPPADUNGORN, KRIENGSAK, PRANA-
KORN BANGKOK, THAILAND, FILED 10-13-2011.

NO CLAIM IS MADE TO THE EXCLUSIVE RIGHT TO USE "THAI" AND THE NON-LATIN CHARACTERS THAT TRANSLITERATE TO "THAI" AND BRAND, APART FROM THE MARK AS SHOWN.

THE MARK CONSISTS OF THE TERM "ROI" IN A STYLIZED FONT ABOVE THE WORD "THAI" IN A STYLIZED FONT WITH SOME "THAI" LANGUAGE CHARACTERS IN A FANCY FONT AND A GRAPHICAL DEPICTION OF A FLOWER IN BETWEEN.

THE ENGLISH TRANSLATION OF "ROI THAI" IN THE MARK IS THAI WAY.

THE NON-LATIN CHARACTERS IN THE MARK TRANSLITERATE TO TRA ROI BRAND AND THIS MEANS THAI WAY BRAND IN ENGLISH.

FOR FOOD SEASONINGS; SEASONING MIXES; SEASONING PASTES; SEASONINGS, NAMELY, HOLY BASIL SEASONING SAUCES (U.S. CL. 46).

MICHELE SWAIN, EXAMINING ATTORNEY

SN 85-446,386. GAONA, ROBERT D., HOBART, IN. FILED
10-13-2011.

The only dog that has no
tail

THE MARK CONSISTS OF STANDARD CHARACTERS WITHOUT CLAIM TO ANY PARTICULAR FONT, STYLE, SIZE, OR COLOR.

FOR HOT DOG SANDWICHES (U.S. CL. 46).

GIANCARLO CASTRO, EXAMINING ATTORNEY

SN 85-446,168. SUSHI TOKYO CI INC., BROOKLYN, NY.
FILED 10-13-2011.

KRISPY KOSARA

THE MARK CONSISTS OF STANDARD CHARACTERS WITHOUT CLAIM TO ANY PARTICULAR FONT, STYLE, SIZE, OR COLOR.

NO CLAIM IS MADE TO THE EXCLUSIVE RIGHT TO USE "CRISPY", APART FROM THE MARK AS SHOWN.

THE ENGLISH TRANSLATION OF "KOSARA" IS "BASKET".

FOR SUSHI (U.S. CL. 46).

FIRST USE 0-0-2008; IN COMMERCE 0-0-2008.
DEBORAH LOBO, EXAMINING ATTORNEY

SN 85-446,658. PURE'S FOOD GROUP, INC., BROADVIEW,
IL. FILED 10-13-2011.

CARLEY'S

THE MARK CONSISTS OF STANDARD CHARACTERS WITHOUT CLAIM TO ANY PARTICULAR FONT, STYLE, SIZE, OR COLOR.

FOR COOKIES; WAFERS (U.S. CL. 46).

FIRST USE 7-1-2000; IN COMMERCE 7-1-2000.

JESSICA A. POWERS, EXAMINING ATTORNEY

CLASS 30—(Continued).

SN 85-446,783. CHOCOLATE PIZZA COMPANY INC., MARCELLUS, NY. FILED 10-13-2011.



NO CLAIM IS MADE TO THE EXCLUSIVE RIGHT TO USE "CHOCOLATE", "PIZZA", AND "COMPANY", APART FROM THE MARK AS SHOWN.

THE MARK CONSISTS OF THE WORDING "THE CHOCOLATE PIZZA COMPANY" IN WHICH THE TYPE STYLE AND SPACING OF THE LETTERING VARIES FOR EACH WORD AND IN WHICH ONE OF THE LETTERS "O" IS STYLIZED IN A PIE CONFIGURATION, TOGETHER WITH A DESIGN OF A CHEF.

FOR CHOCOLATE CONFECTIONS AND CANDY, NAMELY, CHOCOLATES AND CHOCOLATE-BASED READY-TO-EAT CANDIES AND SNACKS, CHOCOLATE-COVERED POTATO CHIPS, CHOCOLATE-COVERED NUTS, CANDY WITH CARAMEL, CANDY IN THE SHAPE OF VARIOUS FOOD ITEMS FASHIONED AT LEAST IN PART OF CHOCOLATE, PEANUT BUTTER, CARAMEL, AND/OR POTATO CHIPS (U.S. CL. 46).
FIRST USE 12-31-1994; IN COMMERCE 12-31-1994.
TOBY BULLOFF, EXAMINING ATTORNEY

SN 85-447,344. MURPHY, LINDA K, CAPTAIN COOK, HI. AND MURPHY, PAUL D, CAPTAIN COOK, HI. FILED 10-14-2011.



THE COLOR(S) GREEN IS/ARE CLAIMED AS A FEATURE OF THE MARK.

THE MARK CONSISTS OF AN IMAGE OF PETROGLYPH TURTLE IN GREEN COLOR AS SHOWN IN THE MARK. FOR COFFEE; COFFEE BEANS; GROUND COFFEE BEANS (U.S. CL. 46).

FIRST USE 3-9-2001; IN COMMERCE 3-9-2001.
BRIDGETT SMITH, EXAMINING ATTORNEY

CLASS 30—(Continued).

SN 85-447,437. FLORES GARCIA, FRANCISCO JAVIER, MONTERREY, NUEVO LEÓN, MEXICO, FILED 10-14-2011.

LA PEÑITA

THE MARK CONSISTS OF STANDARD CHARACTERS WITHOUT CLAIM TO ANY PARTICULAR FONT, STYLE, SIZE, OR COLOR.

THE WORDING "PEÑITA" HAS NO MEANING IN A FOREIGN LANGUAGE.

FOR TOSTADAS (U.S. CL. 46).
FIRST USE 10-26-2006; IN COMMERCE 10-3-2011.
WILLIAM JACKSON, EXAMINING ATTORNEY

SN 85-447,839. DOTCHIRNE PIDPRIEMSTVO "KONDITERSKA KORPORATZIA "ROSHEN", KYIV 02105, UKRAINE, FILED 10-14-2011.



OWNER OF U.S. REG. NO. 3,838,123.
THE MARK CONSISTS OF THE WORDING "ROSHEN" IN A BANNER IN THE SHAPE OF A RIBBON. FOR CONFECTIONERIES, NAMELY, CANDIES, PASTRIES, CHOCOLATE, HARD CANDIES, AND FRUIT JELLY CANDY (U.S. CL. 46).

FIRST USE 1-30-1998; IN COMMERCE 5-22-2008.
MARC LEIPZIG, EXAMINING ATTORNEY

SN 85-447,994. PEACE PIE, INC., SOMERS POINT, NJ. FILED 10-14-2011.

Pie ala Moo

THE MARK CONSISTS OF STANDARD CHARACTERS WITHOUT CLAIM TO ANY PARTICULAR FONT, STYLE, SIZE, OR COLOR.

NO CLAIM IS MADE TO THE EXCLUSIVE RIGHT TO USE "PIE", APART FROM THE MARK AS SHOWN.

FOR FROZEN CONFECTIONS; ICE CREAM DESERTS (U.S. CL. 46).

RONALD MCMORROW, EXAMINING ATTORNEY

CLASS 30—(Continued).

SN 85-448,094. QSL INTELLECTUAL PROPERTIES CORP., SHARON, PA. FILED 10-14-2011.

LUBEBURGER

THE MARK CONSISTS OF STANDARD CHARACTERS WITHOUT CLAIM TO ANY PARTICULAR FONT, STYLE, SIZE, OR COLOR.
FOR HAMBURGER SANDWICHES (U.S. CL. 46).
FIRST USE 12-31-1986; IN COMMERCE 12-31-1986.
CURTIS FRENCH, EXAMINING ATTORNEY

SN 85-448,465. DIETZ, GRANT D., WAYNE, NJ. FILED 10-16-2011.

HALFFEINATED

THE MARK CONSISTS OF STANDARD CHARACTERS WITHOUT CLAIM TO ANY PARTICULAR FONT, STYLE, SIZE, OR COLOR.
FOR COFFEE (U.S. CL. 46).
RICHARD WHITE, EXAMINING ATTORNEY

SN 85-448,627. BARD COFFEE, PORTLAND, ME. FILED 10-17-2011.

BARD COFFEE

THE MARK CONSISTS OF STANDARD CHARACTERS WITHOUT CLAIM TO ANY PARTICULAR FONT, STYLE, SIZE, OR COLOR.
NO CLAIM IS MADE TO THE EXCLUSIVE RIGHT TO USE "COFFEE", APART FROM THE MARK AS SHOWN.
FOR COFFEE; COFFEE BEANS (U.S. CL. 46).
FIRST USE 4-30-2008; IN COMMERCE 4-30-2008.
ANDREA HACK, EXAMINING ATTORNEY

CLASS 30—(Continued).

SN 85-448,773. PURE'S FOOD GROUP, INC., BROADVIEW, IL. FILED 10-17-2011.



THE MARK CONSISTS OF THE WORD "CARLEYS" WRITTEN IN SCRIPT BETWEEN TWO CURVED HORIZONTAL LINES ON A DESIGN OF A COOKIE JAR.
FOR COOKIES; WAFERS (U.S. CL. 46).
FIRST USE 7-1-2000; IN COMMERCE 7-1-2000.
JESSICA A. POWERS, EXAMINING ATTORNEY

SN 85-448,790. TWO FAT GUYS GOURMET SAUCES, DBA TWO FAT GUYS GOURMET SAUCES, MCHENRY, IL. FILED 10-17-2011.

Two Fat Guys

THE MARK CONSISTS OF STANDARD CHARACTERS WITHOUT CLAIM TO ANY PARTICULAR FONT, STYLE, SIZE, OR COLOR.
OWNER OF U.S. REG. NO. 3,717,830.
FOR BARBEQUE SAUCE (U.S. CL. 46).
FIRST USE 12-9-2008; IN COMMERCE 12-9-2008.
TARAH HARDY, EXAMINING ATTORNEY

SN 85-449,095. S.J. MCCULLAGH, INC., BUFFALO, NY. FILED 10-17-2011.

HOW DO YOU LIKE YOUR COFFEE? GREEN!

THE MARK CONSISTS OF STANDARD CHARACTERS WITHOUT CLAIM TO ANY PARTICULAR FONT, STYLE, SIZE, OR COLOR.
FOR COFFEE (U.S. CL. 46).
FRED CARL, EXAMINING ATTORNEY

CLASS 30—(Continued).

SN 85-449,246. TIA'S BAKERY LLC, EL SEGUNDO, CA. FILED 10-17-2011.

Tia's Bakery

THE MARK CONSISTS OF STANDARD CHARACTERS WITHOUT CLAIM TO ANY PARTICULAR FONT, STYLE, SIZE, OR COLOR.

NO CLAIM IS MADE TO THE EXCLUSIVE RIGHT TO USE "BAKERY", APART FROM THE MARK AS SHOWN. THE ENGLISH TRANSLATION OF "TIA'S" IN THE MARK IS "AUNT".

FOR BAKERY GOODS (U.S. CL. 46).
FIRST USE 1-1-2009; IN COMMERCE 1-1-2009.
JOHN GARTNER, EXAMINING ATTORNEY

SN 85-449,507. HELLO PIZZA, EL PASO, TX. FILED 10-18-2011.

PIZZA GARZING

THE MARK CONSISTS OF STANDARD CHARACTERS WITHOUT CLAIM TO ANY PARTICULAR FONT, STYLE, SIZE, OR COLOR.

NO CLAIM IS MADE TO THE EXCLUSIVE RIGHT TO USE "PIZZA", APART FROM THE MARK AS SHOWN.

THE WORDING "GARZING" HAS NO MEANING IN A FOREIGN LANGUAGE.

FOR PIZZA (U.S. CL. 46).
FIRST USE 2-22-2010; IN COMMERCE 3-2-2010.
ELISSA GARBER KON, EXAMINING ATTORNEY

SN 85-449,582. NORTHERN FOODS GROCERY GROUP LIMITED, WEST YORKSHIRE, UNITED KINGDOM, FILED 10-18-2011.

ELKES

THE MARK CONSISTS OF STANDARD CHARACTERS WITHOUT CLAIM TO ANY PARTICULAR FONT, STYLE, SIZE, OR COLOR.

FOR BISCUITS, COOKIES, AND DIGESTIVE BARS, NAMELY, SWEET-MEAL BISCUITS (U.S. CL. 46).

FIRST USE 5-30-2011; IN COMMERCE 5-30-2011.
APRIL ROACH, EXAMINING ATTORNEY

CLASS 30—(Continued).

SN 85-449,589. MASTERS SOFTWARE, DBA HOME SWEET HOME BAKERY, CEDAR PARK, TX. FILED 10-18-2011.

COME AND BAKE IT

THE MARK CONSISTS OF STANDARD CHARACTERS WITHOUT CLAIM TO ANY PARTICULAR FONT, STYLE, SIZE, OR COLOR.

FOR BAKERY GOODS (U.S. CL. 46).
FIRST USE 10-2-2011; IN COMMERCE 10-2-2011.
LINDA ORNDORFF, EXAMINING ATTORNEY

SN 85-449,597. MASTERS SOFTWARE, DBA HOME SWEET HOME BAKERY, CEDAR PARK, TX. FILED 10-18-2011.



COME AND BAKE IT

THE MARK CONSISTS OF A STAR APPEARING ABOVE A SLICE OF CAKE WITH THE WORDS "COME AND BAKE IT" APPEARING BELOW THE SLICE OF CAKE.

FOR BAKERY GOODS (U.S. CL. 46).
FIRST USE 10-2-2011; IN COMMERCE 10-2-2011.
LINDA ORNDORFF, EXAMINING ATTORNEY

SN 85-449,658. ROBIN BEK LLC, CAMPBELL, CA. FILED 10-18-2011.

One Snack Mind

THE MARK CONSISTS OF STANDARD CHARACTERS WITHOUT CLAIM TO ANY PARTICULAR FONT, STYLE, SIZE, OR COLOR.

FOR COOKIES (U.S. CL. 46).
HANNO RITTNER, EXAMINING ATTORNEY

CLASS 30—(Continued).

SN 85-449,704. UNIQUE BRANDS LLC, MONTCLAIR, NJ. FILED 10-18-2011.

KETCHAYO

THE MARK CONSISTS OF STANDARD CHARACTERS WITHOUT CLAIM TO ANY PARTICULAR FONT, STYLE, SIZE, OR COLOR.
FOR FOOD CONDIMENT CONSISTING PRIMARILY OF KETCHUP AND MAYONNAISE (U.S. CL. 46).
DOMINIC J. FERRAIUOLO, EXAMINING ATTORNEY

SN 85-449,753. UNIQUE BRANDS LLC, MONTCLAIR, NJ. FILED 10-18-2011.

BUFFAYO

THE MARK CONSISTS OF STANDARD CHARACTERS WITHOUT CLAIM TO ANY PARTICULAR FONT, STYLE, SIZE, OR COLOR.
FOR FOOD CONDIMENT CONSISTING PRIMARILY OF BUFFALO SAUCE AND MAYONNAISE (U.S. CL. 46).
DOMINIC J. FERRAIUOLO, EXAMINING ATTORNEY

SN 85-450,156. J & J PROCESSING, INC., SANTA FE SPRINGS, CA. FILED 10-18-2011.

Aunt Cyndi's

THE MARK CONSISTS OF STANDARD CHARACTERS WITHOUT CLAIM TO ANY PARTICULAR FONT, STYLE, SIZE, OR COLOR.
OWNER OF U.S. REG. NO. 3,955,501.
THE NAME "AUNT CYNDI" DOES NOT IDENTIFY A LIVING INDIVIDUAL.
FOR MIXES FOR BAKERY GOODS (U.S. CL. 46).
FIRST USE 5-20-2011; IN COMMERCE 5-20-2011.
COURTNEY ALVAREZ, EXAMINING ATTORNEY

CLASS 30—(Continued).

SN 85-450,316. NIMALASURIYA, KSHAMICA SABENA, LOS ANGELES, CA. FILED 10-18-2011.



NO CLAIM IS MADE TO THE EXCLUSIVE RIGHT TO USE "HERBS", APART FROM THE MARK AS SHOWN.
THE MARK CONSISTS OF AN IMAGE OF A LEAF WITH THE STYLIZED TEXT "TRULY HERBS" UNDER IT.
FOR DRIED HERBS (U.S. CL. 46).
B. PARADEWELAI, EXAMINING ATTORNEY

SN 85-451,459. PAPA MURPHY'S INTERNATIONAL, INC., VANCOUVER, WA. FILED 10-19-2011.



THE MARK CONSISTS OF A CROSS SECTION OF A STYLIZED PIZZA CUTTER WITH AN ANGLED HANDLE EXTENDING UPWARD FROM A CIRCULAR BLADE OVER A HORIZONTAL LINE.
FOR UNBAKED PIZZA PREPARED FOR OFF-PREMISES BAKING AND CONSUMPTION (U.S. CL. 46).
JENNIFER VASQUEZ, EXAMINING ATTORNEY

SN 85-451,472. PAPA MURPHY'S INTERNATIONAL, INC., VANCOUVER, WA. FILED 10-19-2011.

**JOIN THE TAKE 'N' BAKE
REVOLUTION**

THE MARK CONSISTS OF STANDARD CHARACTERS WITHOUT CLAIM TO ANY PARTICULAR FONT, STYLE, SIZE, OR COLOR.
FOR UNBAKED PIZZA PREPARED FOR OFF-PREMISES BAKING AND CONSUMPTION (U.S. CL. 46).
FIRST USE 3-1-2011; IN COMMERCE 3-1-2011.
JENNIFER VASQUEZ, EXAMINING ATTORNEY

CLASS 30—(Continued).

SN 85-451,612. IMMUNOTOPIA, LLC, BOERNE, TEXAS, TX. FILED 10-19-2011.



THE MARK CONSISTS OF THE STYLIZED WORDING "SMARTJOE" WITH A GRAPHIC OF A GRADUATION CAP OVER THE LETTER "S".

FOR BEVERAGES MADE OF COFFEE; BEVERAGES WITH A COFFEE BASE; BUBBLE GUM; CANDIES; CANDY; CANDY BARS; CANDY FOR FOOD; CANDY MINTS; CHEWING GUM; CHEWING GUMS; CHOCOLATE CANDIES; CHOCOLATE COVERED ROASTED COFFEE BEANS; CHOCOLATES AND CHOCOLATE BASED READY TO EAT CANDIES AND SNACKS; COFFEE; COFFEE; COFFEE AND COFFEE SUBSTITUTES; COFFEE BASED BEVERAGES; COFFEE BEANS; COFFEE BEVERAGES WITH MILK; COFFEE ESSENCES; COFFEE ESSENCES FOR USE AS SUBSTITUTES FOR COFFEE; COFFEE EXTRACTS; COFFEE EXTRACTS FOR USE AS SUBSTITUTES FOR COFFEE; COFFEE FLAVORED SYRUP USED IN MAKING FOOD BEVERAGES; COFFEE-BASED BEVERAGE CONTAINING MILK; COFFEE-BASED BEVERAGES; FRUIT JELLY CANDY; SUGAR-FREE CHEWING GUM; SUGARFREE CHEWING GUM; SUGARLESS CANDIES; SUGARLESS CHEWING GUM; SWEETS (U.S. CL. 46).

ALYSSA STEEL, EXAMINING ATTORNEY

SN 85-453,128. GUNTHER'S GOURMET GROCERIES, LLC, RICHMOND, VA. FILED 10-21-2011.

GUNTHER'S GOURMET

THE MARK CONSISTS OF STANDARD CHARACTERS WITHOUT CLAIM TO ANY PARTICULAR FONT, STYLE, SIZE, OR COLOR.

NO CLAIM IS MADE TO THE EXCLUSIVE RIGHT TO USE "GOURMET", APART FROM THE MARK AS SHOWN.

FOR (BASED ON USE IN COMMERCE) MARINADES, VINAIGRETTES, SALSA, SALAD DRESSINGS; (BASED ON INTENT TO USE) SAUCES, PICO DE GALLO SAUCE, PICANTE SAUCES (U.S. CL. 46).

FIRST USE 11-0-2000; IN COMMERCE 11-0-2000. KRISTIN DAHLING, EXAMINING ATTORNEY

CLASS 30—(Continued).

SN 85-453,473. THOMAS REAY, NEW HAVEN, MO. FILED 10-21-2011.

intertwined swine

THE MARK CONSISTS OF STANDARD CHARACTERS WITHOUT CLAIM TO ANY PARTICULAR FONT, STYLE, SIZE, OR COLOR.

NO CLAIM IS MADE TO THE EXCLUSIVE RIGHT TO USE "SWINE", APART FROM THE MARK AS SHOWN.

FOR BARBEQUE SAUCE (U.S. CL. 46).

NAPOLEON SHARMA, EXAMINING ATTORNEY

SN 85-453,821. THE MRS. FIELDS' BRAND, INC., SALT LAKE CITY, UT. FILED 10-22-2011.

PRIMITIVE SNACKS

THE MARK CONSISTS OF STANDARD CHARACTERS WITHOUT CLAIM TO ANY PARTICULAR FONT, STYLE, SIZE, OR COLOR.

NO CLAIM IS MADE TO THE EXCLUSIVE RIGHT TO USE "SNACKS", APART FROM THE MARK AS SHOWN.

FOR CAFFEINE-FREE COFFEE; CEREAL BASED ENERGY BARS; COFFEE; COFFEE BASED BEVERAGES; COOKIES; GRAIN-BASED FOOD BARS ALSO CONTAINING SOY, DRIED FRUITS, CHOCOLATE, NUTS, DRIED VEGETABLES, YOGURT, PROTEIN POWDERS, WHEY, EGG; GRANOLA-BASED SNACK BARS; READY TO EAT, CEREAL DERIVED FOOD BARS (U.S. CL. 46).

HANNO RITTNER, EXAMINING ATTORNEY

SN 85-454,446. THE MRS. FIELDS' BRAND, INC., SALT LAKE CITY, UT. FILED 10-24-2011.

PRIMITIVE ENERGY

THE MARK CONSISTS OF STANDARD CHARACTERS WITHOUT CLAIM TO ANY PARTICULAR FONT, STYLE, SIZE, OR COLOR.

NO CLAIM IS MADE TO THE EXCLUSIVE RIGHT TO USE "ENERGY", APART FROM THE MARK AS SHOWN.

FOR CAFFEINE-FREE COFFEE; CEREAL BASED ENERGY BARS; COFFEE; COFFEE BASED BEVERAGES; COOKIES; GRAIN-BASED FOOD BARS ALSO CONTAINING SOY, DRIED FRUITS, CHOCOLATE, NUTS, DRIED VEGETABLES, YOGURT, PROTEIN POWDERS, WHEY, EGG; GRANOLA-BASED SNACK BARS; READY TO EAT, CEREAL DERIVED FOOD BARS (U.S. CL. 46).

HANNO RITTNER, EXAMINING ATTORNEY

CLASS 30—(Continued).

SN 85-456,279. TOPCO HOLDINGS, INC., SKOKIE, IL. FILED 10-26-2011.

GO RIGHT

THE MARK CONSISTS OF STANDARD CHARACTERS WITHOUT CLAIM TO ANY PARTICULAR FONT, STYLE, SIZE, OR COLOR.
FOR READY TO EAT CEREALS (U.S. CL. 46).
KAREN BRACEY, EXAMINING ATTORNEY

SN 85-456,280. TOPCO HOLDINGS, INC., SKOKIE, IL. FILED 10-26-2011.

GO RIGHT CRUNCH

THE MARK CONSISTS OF STANDARD CHARACTERS WITHOUT CLAIM TO ANY PARTICULAR FONT, STYLE, SIZE, OR COLOR.
FOR READY TO EAT CEREALS (U.S. CL. 46).
KAREN BRACEY, EXAMINING ATTORNEY

SN 85-457,241. IMMUNOTOPIA, LLC, BOERNE, TX. FILED 10-26-2011.

Immunotopia

THE MARK CONSISTS OF STANDARD CHARACTERS WITHOUT CLAIM TO ANY PARTICULAR FONT, STYLE, SIZE, OR COLOR.
FOR BEVERAGES MADE OF COFFEE; BEVERAGES WITH A COFFEE BASE; CAFFEINE-FREE COFFEE; CHEWING GUM; CHOCOLATE COVERED ROASTED COFFEE BEANS; COFFEE; COFFEE BEANS; COFFEE ESSENCES; COFFEE EXTRACTS; COFFEE PODS; COFFEE-BASED BEVERAGES; GROUND COFFEE BEANS; ICED COFFEE; INSTANT COFFEE; MIXTURES OF COFFEE AND CHICORY; NATURAL SWEETENER; PREPARED COFFEE AND COFFEE-BASED BEVERAGES; ROASTED COFFEE BEANS; SUGAR-COATED COFFEE BEANS; UNROASTED COFFEE (U.S. CL. 46).
ALYSSA STEEL, EXAMINING ATTORNEY

CLASS 30—(Continued).

SN 85-457,946. WRIGHT, BRUCE DAVID, SARASOTA, FL. FILED 10-27-2011.

BIO crunch

THE MARK CONSISTS OF STANDARD CHARACTERS WITHOUT CLAIM TO ANY PARTICULAR FONT, STYLE, SIZE, OR COLOR.
NO CLAIM IS MADE TO THE EXCLUSIVE RIGHT TO USE "CRUNCH", APART FROM THE MARK AS SHOWN.
FOR BREAKFAST CEREALS (U.S. CL. 46).
DEZMONA MIZELLE, EXAMINING ATTORNEY

SN 85-460,235. GIBSON, SEBASTIAN, AKA GIBSON, RALPH M., PALM DESERT, CA. FILED 10-31-2011.

NITT WITTS

THE MARK CONSISTS OF STANDARD CHARACTERS WITHOUT CLAIM TO ANY PARTICULAR FONT, STYLE, SIZE, OR COLOR.
FOR CANDY (U.S. CL. 46).
BERYL GARDNER, EXAMINING ATTORNEY

SN 85-460,830. SOCIETE DES PRODUITS NESTLE S.A., 1800 VEVEY, SWITZERLAND, FILED 10-31-2011.

CHIPPERBERRY SWIRL

THE MARK CONSISTS OF STANDARD CHARACTERS WITHOUT CLAIM TO ANY PARTICULAR FONT, STYLE, SIZE, OR COLOR.
NO CLAIM IS MADE TO THE EXCLUSIVE RIGHT TO USE "SWIRL", APART FROM THE MARK AS SHOWN.
FOR ICE CREAM; ICE CREAM BARS; FROZEN CONFECTIONS (U.S. CL. 46).
DAVID TAYLOR, EXAMINING ATTORNEY

CLASS 30—(Continued).

SN 85-464,947. FERRERO U.S.A., INC., SOMERSET, NJ.
FILED 11-4-2011.

MAKE YOUR MOMENTS GOLDEN

THE MARK CONSISTS OF STANDARD CHARACTERS WITHOUT CLAIM TO ANY PARTICULAR FONT, STYLE, SIZE, OR COLOR.

FOR PRALINES, CHOCOLATE AND CHOCOLATE PRODUCTS, NAMELY, CHOCOLATE CANDIES (U.S. CL. 46).

DOMINIC FATHY, EXAMINING ATTORNEY

SN 85-474,941. TEAVANA CORPORATION, ATLANTA, GA.
FILED 11-17-2011.

SHANGHAI ORCHID WHITE TEA

THE MARK CONSISTS OF STANDARD CHARACTERS WITHOUT CLAIM TO ANY PARTICULAR FONT, STYLE, SIZE, OR COLOR.

NO CLAIM IS MADE TO THE EXCLUSIVE RIGHT TO USE "ORCHID WHITE TEA", APART FROM THE MARK AS SHOWN.

FOR TEA (U.S. CL. 46).

FIRST USE 10-1-2010; IN COMMERCE 10-1-2010.

TARAH HARDY, EXAMINING ATTORNEY

SN 85-510,352. KELLOGG NORTH AMERICA COMPANY,
BATTLE CREEK, MI. FILED 1-6-2012.

POP-TARTS FESTIVAL FUN

THE MARK CONSISTS OF STANDARD CHARACTERS WITHOUT CLAIM TO ANY PARTICULAR FONT, STYLE, SIZE, OR COLOR.

OWNER OF U.S. REG. NOS. 791,514, 4,043,452 AND OTHERS.

FOR TOASTER PASTRIES (U.S. CL. 46).

MELISSA VALLILLO, EXAMINING ATTORNEY

CLASS 31—NATURAL AGRICULTURAL PRODUCTS

SN 85-132,965. BLACK POINT ASSOCIATES, LLC, DBA
MOULTON, SEATTLE, WA. FILED 9-19-2010.

Garden Bon Bons

THE MARK CONSISTS OF STANDARD CHARACTERS WITHOUT CLAIM TO ANY PARTICULAR FONT, STYLE, SIZE, OR COLOR.

NO CLAIM IS MADE TO THE EXCLUSIVE RIGHT TO USE "GARDEN", APART FROM THE MARK AS SHOWN.

FOR ORGANIC GARDENING KIT FOR INDOOR AND OUTDOOR PLANTING COMPOSED PRIMARILY OF ORGANIC FLOWER AND HERB SEED AND ALSO INCLUDING ORGANIC COMPOST AND CLAY (U.S. CLS. 1 AND 46).

FIRST USE 5-19-2009; IN COMMERCE 5-19-2009.

ROBERT C. CLARK JR., EXAMINING ATTORNEY

SN 85-272,428. CENTRE DE RECHERCHE LES BUISSONS
INC., POINTE-AUX-OUTARDES, CANADA, FILED 3-21-
2011.

ENVOL

THE MARK CONSISTS OF STANDARD CHARACTERS WITHOUT CLAIM TO ANY PARTICULAR FONT, STYLE, SIZE, OR COLOR.

THE ENGLISH TRANSLATION OF "ENVOL" IN THE MARK IS "FLIGHT".

FOR POTATO SEEDS, NAMELY, SEED POTATOES (U.S. CLS. 1 AND 46).

FIRST USE 3-6-2000; IN COMMERCE 3-6-2000.

ELLEN PERKINS, EXAMINING ATTORNEY

SN 85-295,640. ACTIVEPHYTO TECHNOLOGIES LIMITED,
ST. HELIER, JERSEY, FILED 4-14-2011.

PC SPES

THE MARK CONSISTS OF STANDARD CHARACTERS WITHOUT CLAIM TO ANY PARTICULAR FONT, STYLE, SIZE, OR COLOR.

OWNER OF ERPNCMNTY TM OFC REG. NO. 006845812, DATED 5-14-2009, EXPIRES 4-18-2018.

FOR UNPROCESSED GRAINS, AGRICULTURAL GRAINS FOR PLANTING; LIVE ANIMALS; FRESH FRUITS AND VEGETABLES; SEEDS, NATURAL PLANTS AND FLOWERS; FOODSTUFFS FOR ANIMALS, MALT FOR BREWING AND DISTILLING (U.S. CLS. 1 AND 46).

JOHN HWANG, EXAMINING ATTORNEY

CLASS 31—(Continued).

SN 85-306,335. VERMONT ORGANICS RECLAMATION, INC, WILLISTON, VT. FILED 4-27-2011.

GLOBAL WARMING MUMS

THE MARK CONSISTS OF STANDARD CHARACTERS WITHOUT CLAIM TO ANY PARTICULAR FONT, STYLE, SIZE, OR COLOR.

NO CLAIM IS MADE TO THE EXCLUSIVE RIGHT TO USE "MUMS", APART FROM THE MARK AS SHOWN.

FOR FLOWERS, NAMELY, LOW-LIGHT TOLERANT FLOWERS (U.S. CLS. 1 AND 46).

FIRST USE 3-24-2011; IN COMMERCE 3-24-2011.
BARBARA GAYNOR, EXAMINING ATTORNEY

SN 85-375,152. SALIX ANIMAL HEALTH, LLC, DEERFIELD BEACH, FL. FILED 7-19-2011.

GOOD 'N' TASTY

THE MARK CONSISTS OF STANDARD CHARACTERS WITHOUT CLAIM TO ANY PARTICULAR FONT, STYLE, SIZE, OR COLOR.

FOR DOG TREATS (U.S. CLS. 1 AND 46).
JAY BESCH, EXAMINING ATTORNEY

SN 85-398,138. THE PET HYDRATION PEOPLE, CHICAGO, IL. FILED 8-15-2011.



OWNER OF U.S. REG. NO. 4,017,132.

THE MARK CONSISTS OF A SILHOUETTE PROFILE OF A DOG WITH TONGUE WAGGING, ADJACENT TO THE STYLIZED LITERAL ELEMENT "LICKS". THE MARK IS OUTLINED IN A CIRCULAR BORDER WITH FOUR VERTICAL STRIPES OF VARYING WIDTHS AND LENGTHS POSITIONED BEHIND THE SILHOUETTE PROFILE OF THE DOG ALL INSIDE OF A CIRCLE.

FOR PET BEVERAGES (U.S. CLS. 1 AND 46).
FIRST USE 8-25-2010; IN COMMERCE 12-17-2010.
LINDA ORNDORFF, EXAMINING ATTORNEY

CLASS 31—(Continued).

SN 85-435,998. DÜMMEN GMBH, D - 47495 RHEINBERG, FED REP GERMANY, FILED 9-30-2011.

GREEN TAMBOURINE

THE MARK CONSISTS OF STANDARD CHARACTERS WITHOUT CLAIM TO ANY PARTICULAR FONT, STYLE, SIZE, OR COLOR.

NO CLAIM IS MADE TO THE EXCLUSIVE RIGHT TO USE "GREEN", APART FROM THE MARK AS SHOWN.

FOR LIVING PLANTS; NATURAL PLANTS AND FLOWERS; PLANT SEEDS (U.S. CLS. 1 AND 46).
KIMBERLY PERRY, EXAMINING ATTORNEY

SN 85-446,688. DNE WORLD FRUIT LLC, FORT PIERCE, NJ. FILED 10-13-2011.

THE MARK CONSISTS OF A STYLIZED SUN DESIGN SEPARATING THE WORDS "SOL ZEST".

THE ENGLISH TRANSLATION OF "SOL" IN THE MARK IS SUN.

FOR FRESH FRUIT (U.S. CLS. 1 AND 46).
DANIEL CAPSHAW, EXAMINING ATTORNEY

SN 85-447,608. SIDONIE FAUST, NEW ORLEANS, LA. FILED 10-14-2011.

Chew Dat

THE MARK CONSISTS OF STANDARD CHARACTERS WITHOUT CLAIM TO ANY PARTICULAR FONT, STYLE, SIZE, OR COLOR.

NO CLAIM IS MADE TO THE EXCLUSIVE RIGHT TO USE "CHEW", APART FROM THE MARK AS SHOWN.

FOR PET TREATS (U.S. CLS. 1 AND 46).
MICHAEL KEATING, EXAMINING ATTORNEY

CLASS 31—(Continued).

SN 85-447,715. ROY WEINSTEIN, EAST ROCKAWAY, NY. FILED 10-14-2011.

Oh look, it's a baby dog
and he doesn't know any
better. He's eating big dog
food when he should be
eating baby dog food by

THE MARK CONSISTS OF STANDARD CHARACTERS WITHOUT CLAIM TO ANY PARTICULAR FONT, STYLE, SIZE, OR COLOR.

FOR PET FOOD (U.S. CLS. 1 AND 46).
VERNA BETH RIRIE, EXAMINING ATTORNEY

SN 85-448,411. RUFF LIFE, L.L.C., DALLAS, TX. FILED 10-16-2011.

GOODY 2 CHEWZ

THE MARK CONSISTS OF STANDARD CHARACTERS WITHOUT CLAIM TO ANY PARTICULAR FONT, STYLE, SIZE, OR COLOR.

FOR ANIMAL FOODSTUFFS; CAT FOOD; CAT TREATS; DOG BISCUITS; DOG FOOD; DOG TREATS; EDIBLE CHEWS FOR ANIMALS; PET BEVERAGES; PET FOOD (U.S. CLS. 1 AND 46).

WILLIAM VERHOSEK, EXAMINING ATTORNEY

SN 85-448,413. RUFF LIFE, L.L.C., DALLAS, TX. FILED 10-16-2011.

GURRRLATO

THE MARK CONSISTS OF STANDARD CHARACTERS WITHOUT CLAIM TO ANY PARTICULAR FONT, STYLE, SIZE, OR COLOR.

FOR ANIMAL FOODSTUFFS; CAT FOOD; CAT TREATS; DOG BISCUITS; DOG FOOD; DOG TREATS; EDIBLE CHEWS FOR ANIMALS; PET BEVERAGES; PET FOOD (U.S. CLS. 1 AND 46).

WILLIAM VERHOSEK, EXAMINING ATTORNEY

CLASS 31—(Continued).

SN 85-448,415. RUFF LIFE, L.L.C., DALLAS, TX. FILED 10-16-2011.

YOGURRR

THE MARK CONSISTS OF STANDARD CHARACTERS WITHOUT CLAIM TO ANY PARTICULAR FONT, STYLE, SIZE, OR COLOR.

FOR ANIMAL FOODSTUFFS; CAT FOOD; CAT TREATS; DOG BISCUITS; DOG FOOD; DOG TREATS; EDIBLE CHEWS FOR ANIMALS; PET BEVERAGES; PET FOOD (U.S. CLS. 1 AND 46).

WILLIAM VERHOSEK, EXAMINING ATTORNEY

SN 85-448,416. RUFF LIFE, L.L.C., DALLAS, TX. FILED 10-16-2011.

YOPURRR

THE MARK CONSISTS OF STANDARD CHARACTERS WITHOUT CLAIM TO ANY PARTICULAR FONT, STYLE, SIZE, OR COLOR.

FOR ANIMAL FOODSTUFFS; CAT FOOD; CAT TREATS; DOG BISCUITS; DOG FOOD; DOG TREATS; EDIBLE CHEWS FOR ANIMALS; PET BEVERAGES; PET FOOD (U.S. CLS. 1 AND 46).

WILLIAM VERHOSEK, EXAMINING ATTORNEY

SN 85-448,537. DIVINE RIPE, LLC, PHARR, TX. FILED 10-17-2011.

SARITA

THE MARK CONSISTS OF STANDARD CHARACTERS WITHOUT CLAIM TO ANY PARTICULAR FONT, STYLE, SIZE, OR COLOR.

THE ENGLISH TRANSLATION OF "SARITA" IN THE MARK IS "PRINCESS".

FOR FRESH TOMATOES (U.S. CLS. 1 AND 46).

FIRST USE 7-25-2007; IN COMMERCE 7-25-2007.

WILLIAM BRECKENFELD, EXAMINING ATTORNEY

CLASS 31—(Continued).

SN 85-448,541. DIVINE RIPE, LLC, PHARR, TX. FILED 10-17-2011.

REGINA'S

THE MARK CONSISTS OF STANDARD CHARACTERS WITHOUT CLAIM TO ANY PARTICULAR FONT, STYLE, SIZE, OR COLOR.

THE ENGLISH TRANSLATION OF "REGINA" IN THE MARK IS "QUEEN".

FOR FRESH TOMATOES (U.S. CLS. 1 AND 46).

FIRST USE 10-19-2007; IN COMMERCE 10-19-2007.

WILLIAM BRECKENFELD, EXAMINING ATTORNEY

CLASS 31—(Continued).

SN 85-453,737. DEL MONTE CORPORATION, SAN FRANCISCO, CA. FILED 10-21-2011.

COMBOLICIOSO

THE MARK CONSISTS OF STANDARD CHARACTERS WITHOUT CLAIM TO ANY PARTICULAR FONT, STYLE, SIZE, OR COLOR.

OWNER OF U.S. REG. NO. 3,861,389.

FOR PET FOOD (U.S. CLS. 1 AND 46).

DOUGLAS LEE, EXAMINING ATTORNEY

SN 85-448,542. DIVINE RIPE, LLC, PHARR, TX. FILED 10-17-2011.

VALENTINA

THE MARK CONSISTS OF STANDARD CHARACTERS WITHOUT CLAIM TO ANY PARTICULAR FONT, STYLE, SIZE, OR COLOR.

FOR FRESH TOMATOES (U.S. CLS. 1 AND 46).

WILLIAM BRECKENFELD, EXAMINING ATTORNEY

SN 85-457,884. US FEED, LLC, NICHOLASVILLE, KY. FILED 10-27-2011.

RECHARGE

THE MARK CONSISTS OF STANDARD CHARACTERS WITHOUT CLAIM TO ANY PARTICULAR FONT, STYLE, SIZE, OR COLOR.

FOR BEEF STARTER TRANSITION FEED FOR BEEF CATTLE (U.S. CLS. 1 AND 46).

FIRST USE 9-1-2011; IN COMMERCE 9-1-2011.

COURTNEY ALVAREZ, EXAMINING ATTORNEY

SN 85-450,360. DB DISTRIBUTING, INC., FRESNO, CA. FILED 10-18-2011.

MR D'S

THE MARK CONSISTS OF STANDARD CHARACTERS WITHOUT CLAIM TO ANY PARTICULAR FONT, STYLE, SIZE, OR COLOR.

OWNER OF U.S. REG. NO. 3,763,612.

FOR FRESH FRUIT (U.S. CLS. 1 AND 46).

ALEXANDER L. POWERS, EXAMINING ATTORNEY

SN 85-461,709. DNE WORLD FRUIT LLC, FORT PIERCE, NJ. FILED 11-1-2011.

BABY-O

THE MARK CONSISTS OF THE WORDS "BABY O", WITH A STYLIZED LEAF DESIGN ATTACHED TO THE TOP OF THE LETTER "O".

FOR FRESH FRUIT (U.S. CLS. 1 AND 46).

DANIEL CAPSHAW, EXAMINING ATTORNEY

CLASS 31—(Continued).

SN 85-480,469. SCG POWER RANGERS LLC, LOS ANGELES, CA. FILED 11-23-2011.

SUPER MEGAFORCE

THE MARK CONSISTS OF STANDARD CHARACTERS WITHOUT CLAIM TO ANY PARTICULAR FONT, STYLE, SIZE, OR COLOR.

FOR FRESH FRUIT AND VEGETABLES (U.S. CLS. 1 AND 46).

SUNG IN, EXAMINING ATTORNEY

CLASS 32—LIGHT BEVERAGES

SN 79-098,747. ALDARIS, A/S, LATVIA, FILED 5-2-2011.



OWNER OF INTERNATIONAL REGISTRATION 1080954 DATED 5-2-2011, EXPIRES 5-2-2021.

OWNER OF U.S. REG. NO. 2,479,331.

NO CLAIM IS MADE TO THE EXCLUSIVE RIGHT TO USE "ALDARIS" OR "ALUS DARITAVA" OR "LATVIJA RIGA", APART FROM THE MARK AS SHOWN.

THE COLOR(S) DARK RED, RED, GOLDEN, BLACK, WHITE IS/ARE CLAIMED AS A FEATURE OF THE MARK.

THE MARK CONSISTS OF A BANNER IN RED AND DARK RED, WITH BLACK, GOLD AND WHITE EDGING AND A SHEAF OF WHEAT IN GOLD AND BLACK ALONG THE BOTTOM RIGHT EDGE. THE WORD "ALDARIS" IN WHITE APPEARS WITHIN THE BANNER IN A SCRIPT FONT. A ROUND SEAL IN BLACK, GOLD, DARK RED, RED AND WHITE RESTS ATOP SEVERAL SHEAVES OF WHEAT WITH LEAVES IN GOLD AND BLACK JUST ON TOP OF THE BANNER. THE OUTER CIRCLE OF THE SEAL IS BLACK; THE NEXT CONCENTRIC CIRCLE IS GOLD WITH THE WORDING "ALUS DARITAVA ALDARIS LATVIJA" APPEARS IN BLACK WITHIN; THE NEXT TWO CONCENTRIC CIRCLES ARE BLACK AND THEN GOLD, AND THE DARK RED AND RED CENTER CIRCLE CONTAINS A MAN WEARING AN APRON AND THE MAN WITH THE STICK WHO IS STIRRING THE WORT IN THE BARREL AND STANDING NEXT TO A BARREL IN WHITE AND BLACK. THE WORD "RIGA" IN WHITE APPEARS IN A SMALL CURVED DARK RED AND RED BANNER WITH A WHITE BORDER AT THE BOTTOM OF THE SEAL.

THE ENGLISH TRANSLATION OF THE WORDS "ALDARIS", "ALUS DARITAVA", "LATVIJA RIGA" IN THE MARK IS BREWER, BREWERY, LATVIA RIGA ACCORDINGLY.

FOR BEERS (U.S. CLS. 45, 46 AND 48).

ELLEN BURNS, EXAMINING ATTORNEY

CLASS 32—(Continued).

SN 79-104,096. SCHWEPPE'S INTERNATIONAL LIMITED, LONDON, UNITED KINGDOM, FILED 11-12-2010.



OWNER OF INTERNATIONAL REGISTRATION 0998769 DATED 12-19-2008, EXPIRES 12-19-2018.

OWNER OF U.S. REG. NOS. 1,225,237, 2,287,476 AND OTHERS.

THE COLOR(S) LIGHT BLUE, DARK BLUE, ORANGE, YELLOW, AND WHITE IS/ARE CLAIMED AS A FEATURE OF THE MARK.

THE MARK CONSISTS OF THE WHITE WORDING "ORANGINA" OUTLINED WITH DARK BLUE ON A DARK BLUE BACKGROUND WITH A YELLOW CIRCULAR DESIGN OUTLINED WITH LIGHT BLUE CONTAINING AN ORANGE AND YELLOW ORANGE-LIKE BOTTLE DESIGN WITH WHITE BUBBLES.

FOR NON-ALCOHOLIC BEVERAGES, NAMELY, SOFT DRINKS AND FRUIT JUICES; SYRUPS AND CONCENTRATES USED IN THE PREPARATION OF SOFT DRINKS AND FRUIT JUICES (U.S. CLS. 45, 46 AND 48).

LAURA HAMMEL, EXAMINING ATTORNEY

SN 79-104,486. PABLO MONZÓN BLANCO, SPAIN, FILED 7-20-2011.

H2ALL

THE MARK CONSISTS OF STANDARD CHARACTERS WITHOUT CLAIM TO ANY PARTICULAR FONT, STYLE, SIZE, OR COLOR.

PRIORITY DATE OF 7-14-2011 IS CLAIMED.

OWNER OF INTERNATIONAL REGISTRATION 1095581 DATED 7-20-2011, EXPIRES 7-20-2021.

FOR MINERAL AND TABLE WATERS (U.S. CLS. 45, 46 AND 48).

CARYN GLASSER, EXAMINING ATTORNEY

CLASS 32—(Continued).

SN 85-100,724. H & H PRODUCTS CO., ORLANDO, FL.
FILED 8-5-2010.



The logo for "FLAVOR BURST" features the word "FLAVOR" in red, bold, sans-serif capital letters. To its right, the word "BURST" is written in a larger, stylized font where each letter is outlined in black and filled with a different color: 'B' is yellow, 'U' is green, 'R' is red, 'S' is yellow, and 'T' is green.

THE COLOR(S) RED, YELLOW, GREEN AND BLACK IS/ARE CLAIMED AS A FEATURE OF THE MARK.

THE MARK CONSISTS OF THE WORD "FLAVOR" IN CAPITAL LETTERS AND RED FONT WITH THE WORD "BURST" IMMEDIATELY TO THE RIGHT IN LARGER LETTERS OUTLINED IN BLACK WITH AN INNER LINE IN BLACK WHEREIN THE "B" IS YELLOW, THE "U" IS GREEN, THE "R" IS RED, THE "S" IS YELLOW AND THE "T" IS GREEN.

SEC. 2(F).

FOR NON-ALCOHOLIC FRUIT FLAVORED CONCENTRATES USED IN THE PREPARATION OF MIXED ALCOHOLIC DRINKS; FLAVORED SYRUPS FOR USE IN SHAVED ICE CONFECTIONS, SLUSH-TYPE BEVERAGES, FROZEN DRINKS AND DRINK MIXES (U.S. CLS. 45, 46 AND 48).

FIRST USE 8-28-1979; IN COMMERCE 3-21-1980.

ANGELA M. MICHELI, EXAMINING ATTORNEY

SN 85-165,320. PARA VENTURES CORPORATION, WALNUT, CA. FILED 10-29-2010.

DR. JEKYLL'S

THE MARK CONSISTS OF STANDARD CHARACTERS WITHOUT CLAIM TO ANY PARTICULAR FONT, STYLE, SIZE, OR COLOR.

FOR BEER (U.S. CLS. 45, 46 AND 48).

DEIRDRE ROBERTSON, EXAMINING ATTORNEY

SN 85-202,650. BAVARIA S.A., SANTAFE DE BOGOTA, D.C., COLOMBIA, FILED 12-21-2010.

COSTEÑA

THE MARK CONSISTS OF STANDARD CHARACTERS WITHOUT CLAIM TO ANY PARTICULAR FONT, STYLE, SIZE, OR COLOR.

OWNER OF COLOMBIA REG. NO. 189549, DATED 6-28-2006, EXPIRES 6-28-2016.

THE ENGLISH TRANSLATION OF "COSTEÑA" IN THE MARK IS "COAST" OR "COASTAL"

FOR BEER (U.S. CLS. 45, 46 AND 48).

ANGELA DUONG, EXAMINING ATTORNEY

CLASS 32—(Continued).

SN 85-257,312. JOE DIMAGGIO, LLC, HOLLYWOOD, FL.
FILED 3-3-2011.

JOLTIN' JOE

THE MARK CONSISTS OF STANDARD CHARACTERS WITHOUT CLAIM TO ANY PARTICULAR FONT, STYLE, SIZE, OR COLOR.

THE NAME(S), PORTRAIT(S), AND/OR SIGNATURE(S) SHOWN IN THE MARK DOES NOT IDENTIFY A PARTICULAR LIVING INDIVIDUAL.

FOR ENERGY DRINKS; FRUIT DRINKS AND FRUIT JUICES; SMOOTHIES; SMOOTHIES CONTAINING GRAINS AND OATS (U.S. CLS. 45, 46 AND 48).

ELISSA GARBER KON, EXAMINING ATTORNEY

SN 85-289,249. LOLA'S LIBATIONS LLC, COLLEYVILLE, TX.
FILED 4-7-2011.

SMARTINI

THE MARK CONSISTS OF STANDARD CHARACTERS WITHOUT CLAIM TO ANY PARTICULAR FONT, STYLE, SIZE, OR COLOR.

FOR NON-ALCOHOLIC COCKTAIL MIXES (U.S. CLS. 45, 46 AND 48).

FIRST USE 6-17-2010; IN COMMERCE 6-17-2010.

DOMINIC FATHY, EXAMINING ATTORNEY

SN 85-305,550. ALLYSON AMES COMPANY, INC., CORONA DEL MAR, CA. FILED 4-27-2011.

SWEETACULAR

THE MARK CONSISTS OF STANDARD CHARACTERS WITHOUT CLAIM TO ANY PARTICULAR FONT, STYLE, SIZE, OR COLOR.

FOR BEERS AND NONALCOHOLIC DRINKS, NAMELY, FRUIT JUICE, WATER, CARBONATED BEVERAGES, FRUIT PUNCH, ENERGY BEVERAGES, SPORTS BEVERAGES, FLAVORED WATER, VEGETABLE JUICE, FRUIT JUICE, MILK SHAKES, BEER, SYRUPS FOR MAKING BEVERAGES, CONCENTRATES FOR MAKING FRUIT DRINKS (U.S. CLS. 45, 46 AND 48).

FIRST USE 1-1-2005; IN COMMERCE 1-1-2011.

JANICE L. MCMORROW, EXAMINING ATTORNEY

CLASS 32—(Continued).

SN 85-310,509. ALLYSON AMES COMPANY, INC., CORONA DEL MAR, CA. FILED 5-3-2011.

WONDERLICIOUS

THE MARK CONSISTS OF STANDARD CHARACTERS WITHOUT CLAIM TO ANY PARTICULAR FONT, STYLE, SIZE, OR COLOR.

OWNER OF U.S. REG. NO. 3,629,516.
FOR BEERS AND NONALCOHOLIC DRINKS, NAMELY, FRUIT JUICE, WATER, CARBONATED BEVERAGES, FRUIT PUNCH, ENERGY BEVERAGES, SPORTS BEVERAGES, FLAVORED WATER, VEGETABLE JUICE, FRUIT JUICE, MILK SHAKES, BEER, SYRUPS FOR MAKING BEVERAGES, CONCENTRATES FOR MAKING FRUIT DRINKS (U.S. CLS. 45, 46 AND 48).

FIRST USE 1-1-2005; IN COMMERCE 1-1-2011.
JANICE L. MCMORROW, EXAMINING ATTORNEY

SN 85-384,208. BOVIS FOODS, LLC, SAN MATEO, CA. FILED 7-29-2011.

MARGARITA ZERO

THE MARK CONSISTS OF STANDARD CHARACTERS WITHOUT CLAIM TO ANY PARTICULAR FONT, STYLE, SIZE, OR COLOR.

NO CLAIM IS MADE TO THE EXCLUSIVE RIGHT TO USE "MARGARITA", APART FROM THE MARK AS SHOWN.

SEC. 2(F).
FOR NON-ALCOHOLIC COCKTAIL MIXES (U.S. CLS. 45, 46 AND 48).

FIRST USE 0-0-2001; IN COMMERCE 0-0-2001.
MICHAEL LITZAU, EXAMINING ATTORNEY

SN 85-389,894. CASEY GLOBAL, LLC, BOSTON, MA. FILED 8-4-2011.

SLAMMIN' SAM

THE MARK CONSISTS OF STANDARD CHARACTERS WITHOUT CLAIM TO ANY PARTICULAR FONT, STYLE, SIZE, OR COLOR.

FOR BEVERAGES, NAMELY, BEER (U.S. CLS. 45, 46 AND 48).

MARTHA FROMM, EXAMINING ATTORNEY

CLASS 32—(Continued).

SN 85-405,554. JOHN B. SANFILIPPO & SON, INC., ELGIN, IL. FILED 8-24-2011.

ARMA ENERGY

THE MARK CONSISTS OF STANDARD CHARACTERS WITHOUT CLAIM TO ANY PARTICULAR FONT, STYLE, SIZE, OR COLOR.

NO CLAIM IS MADE TO THE EXCLUSIVE RIGHT TO USE "ENERGY", APART FROM THE MARK AS SHOWN.

FOR NON-ALCOHOLIC BEVERAGES, NAMELY, ENERGY DRINKS, SPORTS DRINKS AND SOFT DRINKS FOR USE BY ATHLETES AND THOSE ENGAGED IN ACTIVE OR STRESSFUL SPORTS AND ACTIVITIES; SPORTS DRINKS, NAMELY, PERFORMANCE ENHANCING DRINKS (U.S. CLS. 45, 46 AND 48).

DAVID TAYLOR, EXAMINING ATTORNEY

SN 85-407,485. COFFEE TECHNOLOGY COMPANY, LLC, NASHVILLE, TN. FILED 8-25-2011.

ISLAND ROX MIXERS

THE MARK CONSISTS OF STANDARD CHARACTERS WITHOUT CLAIM TO ANY PARTICULAR FONT, STYLE, SIZE, OR COLOR.

NO CLAIM IS MADE TO THE EXCLUSIVE RIGHT TO USE "MIXERS", APART FROM THE MARK AS SHOWN.

FOR NON-ALCOHOLIC COCKTAIL MIXES (U.S. CLS. 45, 46 AND 48).

FIRST USE 8-11-2011; IN COMMERCE 8-11-2011.
KIMBERLY FRYE, EXAMINING ATTORNEY

SN 85-419,443. FERRIS, PETER V., RYE, NH. FILED 9-9-2011.

FRESH SAMANTHA

THE MARK CONSISTS OF STANDARD CHARACTERS WITHOUT CLAIM TO ANY PARTICULAR FONT, STYLE, SIZE, OR COLOR.

NO CLAIM IS MADE TO THE EXCLUSIVE RIGHT TO USE "FRESH", APART FROM THE MARK AS SHOWN.

FOR FRUIT JUICES AND FRUIT DRINKS (U.S. CLS. 45, 46 AND 48).

ALLISON HOLTZ, EXAMINING ATTORNEY

CLASS 32—(Continued).

SN 85-420,462. TRIPLE VENTURES, LLC, OWINGS, MD.
FILED 9-12-2011.



NO CLAIM IS MADE TO THE EXCLUSIVE RIGHT TO USE "FRUIT", APART FROM THE MARK AS SHOWN.

THE COLOR(S) BLUE, WHITE AND BLACK IS/ARE CLAIMED AS A FEATURE OF THE MARK.

THE MARK CONSISTS OF A BLUE AND WHITE OVOID DESIGN APPEARING AS A WATER WHIRLPOOL, WITH WATER DROPS EMANATING FROM THE TOP LEFT AND RIGHT SIDES AND WITH THE WORDS, "FRUIT WAVE" IN BLACK AND OUTLINED IN WHITE AND BLUE CURVING THROUGH THE CENTER OF THE WHIRLPOOL FROM LEFT TO RIGHT.

FOR FLAVORED BOTTLED WATER; FLAVORED WATERS; FRUIT FLAVORED DRINKS; FRUIT-FLAVORED BEVERAGES (U.S. CLS. 45, 46 AND 48).

FIRST USE 6-8-2011; IN COMMERCE 6-8-2011.
KYLE PEETE, EXAMINING ATTORNEY

SN 85-434,408. MIRA INTERNATIONAL FOODS, INC., EAST BRUNSWICK, NJ. FILED 9-28-2011.

VOY!

THE MARK CONSISTS OF STANDARD CHARACTERS WITHOUT CLAIM TO ANY PARTICULAR FONT, STYLE, SIZE, OR COLOR.

THE ENGLISH TRANSLATION OF "VOY" IN THE MARK IS "I GO".

FOR ALOE VERA BEVERAGE (U.S. CLS. 45, 46 AND 48).

FIRST USE 8-11-2010; IN COMMERCE 8-11-2010.
SHAUNIA CARLYLE, EXAMINING ATTORNEY

SN 85-437,384. MOCKTAIL BEVERAGES, INC., WENHAM, MA. FILED 10-3-2011.

The Fiji Squeezy

THE MARK CONSISTS OF STANDARD CHARACTERS WITHOUT CLAIM TO ANY PARTICULAR FONT, STYLE, SIZE, OR COLOR.

FOR NON-ALCOHOLIC COCKTAILS (U.S. CLS. 45, 46 AND 48).

SALLY SHIH, EXAMINING ATTORNEY

CLASS 32—(Continued).

SN 85-437,386. MOCKTAIL BEVERAGES, INC., WENHAM, MA. FILED 10-3-2011.

The Passionate Fruit

THE MARK CONSISTS OF STANDARD CHARACTERS WITHOUT CLAIM TO ANY PARTICULAR FONT, STYLE, SIZE, OR COLOR.

NO CLAIM IS MADE TO THE EXCLUSIVE RIGHT TO USE "FRUIT", APART FROM THE MARK AS SHOWN.

FOR NON-ALCOHOLIC COCKTAILS (U.S. CLS. 45, 46 AND 48).

SALLY SHIH, EXAMINING ATTORNEY

SN 85-437,389. MOCKTAIL BEVERAGES, INC., WENHAM, MA. FILED 10-3-2011.

The Cold One

THE MARK CONSISTS OF STANDARD CHARACTERS WITHOUT CLAIM TO ANY PARTICULAR FONT, STYLE, SIZE, OR COLOR.

NO CLAIM IS MADE TO THE EXCLUSIVE RIGHT TO USE "COLD", APART FROM THE MARK AS SHOWN.

FOR NON-ALCOHOLIC COCKTAILS (U.S. CLS. 45, 46 AND 48).

SALLY SHIH, EXAMINING ATTORNEY

SN 85-442,617. BAYOU TECHE BREWING, LLC, ARNAUDVILLE, LA. FILED 10-7-2011.



NO CLAIM IS MADE TO THE EXCLUSIVE RIGHT TO USE "LA" AND THE DESIGN OF THE STATE OF LOUISIANA, APART FROM THE MARK AS SHOWN.

THE MARK CONSISTS OF THE TEXT "LA 31" WRITTEN ON AN OUTLINE OF THE STATE OF LOUISIANA, AND THE OUTLINE OF THE STATE IS ON A SOLID SQUARE BACKGROUND.

FOR BEER (U.S. CLS. 45, 46 AND 48).

FIRST USE 7-1-2009; IN COMMERCE 2-1-2010.

JOHN DWYER, EXAMINING ATTORNEY

CLASS 32—(Continued).

SN 85-442,648. LIL' MAN BREWING, VENTURA, CA. FILED 10-7-2011.

Lil' Man Brewing

THE MARK CONSISTS OF STANDARD CHARACTERS WITHOUT CLAIM TO ANY PARTICULAR FONT, STYLE, SIZE, OR COLOR.

NO CLAIM IS MADE TO THE EXCLUSIVE RIGHT TO USE "BREWING", APART FROM THE MARK AS SHOWN. FOR BEER (U.S. CLS. 45, 46 AND 48).
FONG HSU, EXAMINING ATTORNEY

SN 85-442,688. MYCABO.COM, LA JOLLA, CA. FILED 10-7-2011.

BANDOLERO

THE MARK CONSISTS OF STANDARD CHARACTERS WITHOUT CLAIM TO ANY PARTICULAR FONT, STYLE, SIZE, OR COLOR.

THE ENGLISH TRANSLATION OF "BANDOLERO" IN THE MARK IS BANDIT.

FOR ALCOHOL-FREE BEERS; BEER; BEER WORT; BEER, ALE AND LAGER; BEER, ALE AND PORTER; BEER, ALE, LAGER, STOUT AND PORTER; BEER, ALE, LAGER, STOUT, PORTER, SHANDY; BEER-BASED COOLERS; BEERS; BLACK BEER; BREWED MALT-BASED ALCOHOLIC BEVERAGE IN THE NATURE OF A BEER; COFFEE-FLAVORED BEER; DE-ALCOHOLED BEER; EXTRACTS OF HOPS FOR MAKING BEER; FLAVORED BEERS; FLAVORED BREWED MALT BEVERAGES; GINGER BEER; HOP EXTRACTS FOR MANUFACTURING BEER; IMITATION BEER; MALT BEER; MALT EXTRACTS FOR MAKING BEER; MALT LIQUOR; NON-ALCOHOLIC BEER; PALE BEER; PORTER (U.S. CLS. 45, 46 AND 48).

KEVON CHISOLM, EXAMINING ATTORNEY

SN 85-444,377. MURPHY OIL USA, INC., EL DORADO, AZ. FILED 10-11-2011.

CITRUS INVASION

THE MARK CONSISTS OF STANDARD CHARACTERS WITHOUT CLAIM TO ANY PARTICULAR FONT, STYLE, SIZE, OR COLOR.

NO CLAIM IS MADE TO THE EXCLUSIVE RIGHT TO USE "CITRUS", APART FROM THE MARK AS SHOWN.

FOR NON-ALCOHOLIC BEVERAGES, NAMELY, CARBONATED BEVERAGES (U.S. CLS. 45, 46 AND 48).

ANDREA BUTLER, EXAMINING ATTORNEY

CLASS 32—(Continued).

SN 85-445,554. THEPPADUNGORN, KRIENGSACK, PRANA-KORN BANGKOK, THAILAND, FILED 10-12-2011.



THE MARK CONSISTS OF THE GRAPHICAL DEPICTION OF A FLAG WITH THE WORDING "KING ISLAND" IN THE CENTER WITH PALM TREE BRANCHES ARRANGED IN THE TOP LEFT CORNER AND BOTTOM RIGHT CORNER.

FOR COCONUT JUICE; COCONUT WATER; COCONUT-BASED BEVERAGES (U.S. CLS. 45, 46 AND 48).
MICHELE SWAIN, EXAMINING ATTORNEY

SN 85-445,606. THEPPADUNGORN, KRIENGSACK, PRANA-KORN BANGKOK, THAILAND, FILED 10-12-2011.



NO CLAIM IS MADE TO THE EXCLUSIVE RIGHT TO USE THE NON-LATIN CHARACTERS THAT TRANSLITERATE TO BRAND, APART FROM THE MARK AS SHOWN.

THE MARK CONSISTS OF THE GRAPHICAL DEPICTION OF THE TERM "V-FIT" IN A FANCIFUL FONT OVER A SLASH MARK WITH THAI LETTERING FOR THE WORD TRA "V-FIT" PRINTED IN THAI ON THE SLASH MARK.

THE NON-LATIN CHARACTERS IN THE MARK TRANSLITERATE TO TRA "V-FIT" AND THIS MEANS "V-FIT" BRAND IN ENGLISH.

FOR NON-ALCOHOLIC RICE-BASED BEVERAGES NOT BEING MILK SUBSTITUTES (U.S. CLS. 45, 46 AND 48).

MICHELE SWAIN, EXAMINING ATTORNEY

CLASS 32—(Continued).

SN 85-446,143. SEA BREEZE FRUIT FLAVORS, INC., TO-WACO, NJ. FILED 10-13-2011.

SEA BREEZE ICED TEA

THE MARK CONSISTS OF STANDARD CHARACTERS WITHOUT CLAIM TO ANY PARTICULAR FONT, STYLE, SIZE, OR COLOR.

OWNER OF U.S. REG. NOS. 3,568,324, 3,762,240 AND OTHERS.

NO CLAIM IS MADE TO THE EXCLUSIVE RIGHT TO USE "ICED TEA", APART FROM THE MARK AS SHOWN.

FOR SYRUPS FOR MAKING SOFT DRINKS AND NONALCOHOLIC COCKTAIL MIXES (U.S. CLS. 45, 46 AND 48).

FIRST USE 1-1-1990; IN COMMERCE 1-1-1990.
MICHAEL ENGEL, EXAMINING ATTORNEY

SN 85-446,488. GREEN MOUNTAIN COFFEE ROASTERS, INC., WATERBURY, VT. FILED 10-13-2011.

GREEN MOUNTAIN NATURALS

THE MARK CONSISTS OF STANDARD CHARACTERS WITHOUT CLAIM TO ANY PARTICULAR FONT, STYLE, SIZE, OR COLOR.

OWNER OF U.S. REG. NOS. 1,631,794, 3,755,361 AND OTHERS.

NO CLAIM IS MADE TO THE EXCLUSIVE RIGHT TO USE "NATURALS", APART FROM THE MARK AS SHOWN.

FOR PREPARATIONS FOR MAKING FRUIT-BASED BEVERAGES; FRUIT PUREES FOR MAKING FRUIT-BASED BEVERAGES (U.S. CLS. 45, 46 AND 48).

FIRST USE 10-23-2010; IN COMMERCE 10-23-2010.
TOBY BULLOFF, EXAMINING ATTORNEY

SN 85-446,571. JAMES ELLISON, CRAIG, AK. FILED 10-13-2011.

Bunker Water

THE MARK CONSISTS OF STANDARD CHARACTERS WITHOUT CLAIM TO ANY PARTICULAR FONT, STYLE, SIZE, OR COLOR.

NO CLAIM IS MADE TO THE EXCLUSIVE RIGHT TO USE "WATER", APART FROM THE MARK AS SHOWN.

FOR BOTTLED DRINKING WATER (U.S. CLS. 45, 46 AND 48).

CHARLES L. JENKINS, EXAMINING ATTORNEY

CLASS 32—(Continued).

SN 85-446,591. GREEN MOUNTAIN COFFEE ROASTERS, INC., WATERBURY, VT. FILED 10-13-2011.



OWNER OF U.S. REG. NOS. 1,631,794, 3,755,361 AND OTHERS.

NO CLAIM IS MADE TO THE EXCLUSIVE RIGHT TO USE "NATURALS", APART FROM THE MARK AS SHOWN.

THE MARK CONSISTS OF THE WORD ELEMENTS "GREEN MOUNTAIN NATURALS" WITH A STYLIZED APPLE OVER THE LETTER "S" IN "NATURALS".

FOR PREPARATIONS FOR MAKING FRUIT-BASED BEVERAGES; FRUIT PUREES FOR MAKING FRUIT-BASED BEVERAGES (U.S. CLS. 45, 46 AND 48).

FIRST USE 10-23-2010; IN COMMERCE 10-23-2010.
TOBY BULLOFF, EXAMINING ATTORNEY

SN 85-446,921. STRAUB BREWERY, INC., ST. MARYS, PA. FILED 10-13-2011.

FIRST WATER

THE MARK CONSISTS OF STANDARD CHARACTERS WITHOUT CLAIM TO ANY PARTICULAR FONT, STYLE, SIZE, OR COLOR.

FOR BEER (U.S. CLS. 45, 46 AND 48).
MICHAEL KEATING, EXAMINING ATTORNEY

SN 85-447,410. COMIDAS Y BEBIDAS FERMENTADAS, S.A. DE C.V., MONTERREY, NUEVO LEÓN, MEXICO, FILED 10-14-2011.

NÉCTAR DE LOS DIOS

THE MARK CONSISTS OF STANDARD CHARACTERS WITHOUT CLAIM TO ANY PARTICULAR FONT, STYLE, SIZE, OR COLOR.

THE ENGLISH TRANSLATION OF "NÉCTAR DE LOS DIOS" IN THE MARK IS "NECTAR OF THE GODS".

FOR BEER (U.S. CLS. 45, 46 AND 48).
FIRST USE 3-10-2011; IN COMMERCE 3-10-2011.
SARA BENJAMIN, EXAMINING ATTORNEY

CLASS 32—(Continued).

SN 85-447,736. STRAUB BREWERY, INC., ST. MARYS, PA. FILED 10-14-2011.

FIERCELY INDEPENDENT

THE MARK CONSISTS OF STANDARD CHARACTERS WITHOUT CLAIM TO ANY PARTICULAR FONT, STYLE, SIZE, OR COLOR.

FOR BEER (U.S. CLS. 45, 46 AND 48).
MICHAEL KEATING, EXAMINING ATTORNEY

SN 85-448,509. P-HGH, LLC, JACKSONVILLE, FL. FILED 10-17-2011.

**THERE IS ONLY 1 TRUE
AUTHENTIC - TOTAL
DOMINATION TAKES FULL
CONCENTRATION**

THE MARK CONSISTS OF STANDARD CHARACTERS WITHOUT CLAIM TO ANY PARTICULAR FONT, STYLE, SIZE, OR COLOR.

FOR SPORTS DRINKS; SPORTS DRINKS CONTAINING ELECTROLYTES; SPORTS DRINKS ENHANCED WITH NUTRIENTS; SPORTS DRINKS, NAMELY, PERFORMANCE DRINKS; SPORTS DRINKS, NAMELY, RECOVERY DRINKS (U.S. CLS. 45, 46 AND 48).
LINDA ESTRADA, EXAMINING ATTORNEY

SN 85-448,599. KELTSCH, MICHAEL, SAN RAMON, CA. FILED 10-17-2011.

DrinkSlinger

THE MARK CONSISTS OF STANDARD CHARACTERS WITHOUT CLAIM TO ANY PARTICULAR FONT, STYLE, SIZE, OR COLOR.

FOR FRUIT JUICES; HERBAL JUICES; MIXED FRUIT JUICE; NON-ALCOHOLIC COCKTAIL MIXES; NON-ALCOHOLIC FRUIT JUICE BEVERAGES (U.S. CLS. 45, 46 AND 48).
THOMAS MANOR, EXAMINING ATTORNEY

CLASS 32—(Continued).

SN 85-448,787. DUQUESNE BREWING COMPANY, PITTSBURGH, PA. FILED 10-17-2011.

FORT PITT THAT'S IT!

THE MARK CONSISTS OF STANDARD CHARACTERS WITHOUT CLAIM TO ANY PARTICULAR FONT, STYLE, SIZE, OR COLOR.

FOR BEER (U.S. CLS. 45, 46 AND 48).
TARAH HARDY, EXAMINING ATTORNEY

SN 85-449,207. FRASER AND NEAVE LIMITED, SINGAPORE, SINGAPORE, FILED 10-17-2011.



THE COLOR(S) RED, BLUE, GREEN, AND WHITE IS/ARE CLAIMED AS A FEATURE OF THE MARK.

THE MARK CONSISTS OF THE NUMBER "100" IN WHITE OVER A THREE-STRIPED BACKGROUND WITH THE LEFT STRIPE BEING BLUE, THE MIDDLE STRIPE BEING RED, AND THE RIGHT STRIPE BEING GREEN. THE WORD "PLUS" IS IN BLUE NEXT TO THE THREE-STRIPED BACKGROUND.

FOR AERATED AND MINERAL WATERS; ISOTONIC DRINKS; FRUIT JUICES AND FRUIT DRINKS, FRUIT CONCENTRATES FOR USE IN PREPARATION OF CARBONATED AND NON-CARBONATED SOFT DRINKS; AND SYRUPS FOR MAKING AERATED AND MINERAL WATERS (U.S. CLS. 45, 46 AND 48).

FIRST USE 10-16-2003; IN COMMERCE 10-16-2003.
TASNEEM HUSSAIN, EXAMINING ATTORNEY

CLASS 32—(Continued).

SN 85-449,911. ANHEUSER-BUSCH, LLC, ST. LOUIS, MO.
FILED 10-18-2011.

VALORA LO BUENO

THE MARK CONSISTS OF STANDARD CHARACTERS
WITHOUT CLAIM TO ANY PARTICULAR FONT, STYLE,
SIZE, OR COLOR.

THE ENGLISH TRANSLATION OF "VALORA LO BUE-
NO" IN THE MARK IS "APPRECIATE THE GOOD".

FOR BEER (U.S. CLS. 45, 46 AND 48).

FIRST USE 12-31-2009; IN COMMERCE 12-31-2009.

NANCY CLARKE, EXAMINING ATTORNEY

CLASS 32—(Continued).

SN 85-453,824. THE MRS. FIELDS' BRAND, INC., SALT
LAKE CITY, UT. FILED 10-22-2011.

PRIMITIVE SNACKS

THE MARK CONSISTS OF STANDARD CHARACTERS
WITHOUT CLAIM TO ANY PARTICULAR FONT, STYLE,
SIZE, OR COLOR.

NO CLAIM IS MADE TO THE EXCLUSIVE RIGHT TO
USE "SNACKS", APART FROM THE MARK AS SHOWN.

FOR COCONUT WATER; COCONUT-BASED NON-
ALCOHOLIC BEVERAGES; CONCENTRATES AND
POWDERS USED IN THE PREPARATION OF ENERGY
DRINKS AND FRUIT-FLAVORED BEVERAGES; CON-
CENTRATES, SYRUPS OR POWDERS USED IN THE
PREPARATION OF SPORTS AND ENERGY DRINKS;
ENERGY DRINKS; FRUIT DRINKS; FRUIT DRINKS
AND FRUIT JUICES; POWDERS USED IN THE PRE-
PARATION OF FRUIT-BASED BEVERAGES; PREPARED
ENTREES CONSISTING OF FRUIT DRINKS AND
FRUIT JUICES, FRUIT-BASED BEVERAGES, NON-AL-
COHOLIC BEVERAGES CONTAINING FRUIT JUICES,
NON-ALCOHOLIC FRUIT EXTRACTS USED IN THE
PREPARATION OF BEVERAGES, NON-ALCOHOLIC
FRUIT JUICE BEVERAGES, VEGETABLE JUICES, VE-
GETABLE-FRUIT JUICES AND SMOOTHIES;
SMOOTHIES; SMOOTHIES CONTAINING GRAINS
AND OATS; SPORTS DRINKS; SPORTS DRINKS CON-
TAINING ELECTROLYTES; VEGETABLE DRINKS (U.S.
CLS. 45, 46 AND 48).

HANNO RITTNER, EXAMINING ATTORNEY

SN 85-454,565. THE MRS. FIELDS' BRAND, INC., SALT
LAKE CITY, UT. FILED 10-24-2011.

PRIMITIVE ENERGY

THE MARK CONSISTS OF STANDARD CHARACTERS
WITHOUT CLAIM TO ANY PARTICULAR FONT, STYLE,
SIZE, OR COLOR.

NO CLAIM IS MADE TO THE EXCLUSIVE RIGHT TO
USE "ENERGY", APART FROM THE MARK AS SHOWN.

FOR COCONUT WATER; COCONUT-BASED NON-
ALCOHOLIC BEVERAGES; CONCENTRATES AND
POWDERS USED IN THE PREPARATION OF ENERGY
DRINKS AND FRUIT-FLAVORED BEVERAGES; CON-
CENTRATES, SYRUPS OR POWDERS USED IN THE
PREPARATION OF SPORTS AND ENERGY DRINKS;
ENERGY DRINKS; FRUIT DRINKS; FRUIT DRINKS
AND FRUIT JUICES; POWDERS USED IN THE PRE-
PARATION OF FRUIT-BASED BEVERAGES; PREPARED
ENTREES CONSISTING OF FRUIT DRINKS AND
FRUIT JUICES, FRUIT-BASED BEVERAGES, NON-AL-
COHOLIC BEVERAGES CONTAINING FRUIT JUICES,
NON-ALCOHOLIC FRUIT EXTRACTS USED IN THE
PREPARATION OF BEVERAGES, NON-ALCOHOLIC
FRUIT JUICE BEVERAGES, VEGETABLE JUICES, VE-
GETABLE-FRUIT JUICES AND SMOOTHIES;
SMOOTHIES; SMOOTHIES CONTAINING GRAINS
AND OATS; SPORTS DRINKS; SPORTS DRINKS CON-
TAINING ELECTROLYTES; VEGETABLE DRINKS (U.S.
CLS. 45, 46 AND 48).

HANNO RITTNER, EXAMINING ATTORNEY

SN 85-452,101. B C MARKETING CONCEPTS, INC., DBA
FULL SAIL BREWING COMPANY, HOOD RIVER, OR.
FILED 10-20-2011.

**STOKED TO BREW BREWED TO
STOKE**

THE MARK CONSISTS OF STANDARD CHARACTERS
WITHOUT CLAIM TO ANY PARTICULAR FONT, STYLE,
SIZE, OR COLOR.

FOR BEER, ALE, LAGER, STOUT AND PORTER;
BREWED MALT-BASED ALCOHOLIC BEVERAGE IN
THE NATURE OF A BEER (U.S. CLS. 45, 46 AND 48).

FIRST USE 12-15-2004; IN COMMERCE 3-31-2005.

JERI J. FICKES, EXAMINING ATTORNEY

CLASS 32—(Continued).

SN 85-457,957. WRIGHT, BRUCE DAVID, SARASOTA, FL. FILED 10-27-2011.

BIO juice

THE MARK CONSISTS OF STANDARD CHARACTERS WITHOUT CLAIM TO ANY PARTICULAR FONT, STYLE, SIZE, OR COLOR.

NO CLAIM IS MADE TO THE EXCLUSIVE RIGHT TO USE "JUICE", APART FROM THE MARK AS SHOWN. FOR FRUIT JUICE; HERBAL JUICES; VEGETABLE JUICE (U.S. CLS. 45, 46 AND 48).

DEZMONA MIZELLE, EXAMINING ATTORNEY

SN 85-461,951. ADVANCED FOOD CONCEPTS, INC., BERKELEY, CA. FILED 11-1-2011.

GU

THE MARK CONSISTS OF STANDARD CHARACTERS WITHOUT CLAIM TO ANY PARTICULAR FONT, STYLE, SIZE, OR COLOR.

OWNER OF U.S. REG. NOS. 3,495,529, 3,779,086 AND OTHERS.

FOR NON-ALCOHOLIC BEVERAGES, NAMELY, SPORTS DRINKS INFUSED WITH MALTODEXTRIN, PROTEIN, CARBOHYDRATES, VITAMINS AND ELECTROLYTES; ENERGY DRINKS; SPORTS DRINKS; CONCENTRATES, TABLETS AND POWDERS FOR USE IN PREPARATION OF SPORTS DRINKS (U.S. CLS. 45, 46 AND 48).

FIRST USE 3-0-1994; IN COMMERCE 3-0-1994.
SUNG IN, EXAMINING ATTORNEY

SN 85-464,103. OMAHA STEAKS INTERNATIONAL, INC., OMAHA, NE. FILED 11-3-2011.

A LA ZING

THE MARK CONSISTS OF STANDARD CHARACTERS WITHOUT CLAIM TO ANY PARTICULAR FONT, STYLE, SIZE, OR COLOR.

OWNER OF U.S. REG. NOS. 2,599,010 AND 2,669,995. FOR BOTTLED DRINKING WATER; FLAVORED BOTTLED WATER; BEER; FRUIT DRINKS AND JUICES; NON-ALCOHOLIC BEVERAGES, NAMELY, CARBONATED BEVERAGES; NON-ALCOHOLIC BEVERAGES CONTAINING FRUIT JUICES (U.S. CLS. 45, 46 AND 48).

CAROLYN CATALDO, EXAMINING ATTORNEY

CLASS 32—(Continued).

SN 85-466,786. TOPCO HOLDINGS, INC., SKOKIE, IL. FILED 11-8-2011.

Squēēz!

THE MARK CONSISTS OF STANDARD CHARACTERS WITHOUT CLAIM TO ANY PARTICULAR FONT, STYLE, SIZE, OR COLOR.

FOR REFRIGERATED, FROZEN, AND SHELF STABLE FRUIT JUICES AND JUICE BLENDS INCLUDING BOTH FROM-CONCENTRATE AND NOT FROM CONCENTRATE JUICES; AND FRUIT SMOOTHIES SOLD EXCLUSIVELY IN RETAIL GROCERY STORES (U.S. CLS. 45, 46 AND 48).

KAREN BRACEY, EXAMINING ATTORNEY

SN 85-475,848. APPEL, PAULETTE, SPENCER, IA. FILED 11-17-2011.

ARNOLDS DARK

THE MARK CONSISTS OF STANDARD CHARACTERS WITHOUT CLAIM TO ANY PARTICULAR FONT, STYLE, SIZE, OR COLOR.

NO CLAIM IS MADE TO THE EXCLUSIVE RIGHT TO USE "DARK", APART FROM THE MARK AS SHOWN. FOR BEER, ALE, STOUT (U.S. CLS. 45, 46 AND 48).

JOHN GARTNER, EXAMINING ATTORNEY

SN 85-481,502. SABERTOOTH MOTORCYCLES, LLC, CHESTNUT HILL, MA. FILED 11-28-2011.

WildCat

THE MARK CONSISTS OF STANDARD CHARACTERS WITHOUT CLAIM TO ANY PARTICULAR FONT, STYLE, SIZE, OR COLOR.

OWNER OF U.S. REG. NOS. 3,490,382, 3,580,465 AND OTHERS.

FOR BEER; BOTTLED WATER; ENERGY DRINKS; FLAVORED BOTTLED WATER; POWDERS USED IN THE PREPARATION OF ISOTONIC SPORTS DRINKS AND SPORTS BEVERAGES; SOFT DRINKS; SOFT DRINKS, NAMELY, SODAS; SPORTS DRINKS; SPORTS DRINKS, NAMELY, ENERGY DRINKS (U.S. CLS. 45, 46 AND 48).

FIRST USE 12-15-2005; IN COMMERCE 3-1-2006.

MARK SHINER, EXAMINING ATTORNEY

CLASS 32—(Continued).

SN 85-507,575. MILLERCOORS LLC, CHICAGO, IL. FILED 1-3-2012.



THE MARK CONSISTS OF THE WORDS "COORS RECYCLES" IN A STYLIZED FONT, BENEATH THREE ARROWS THAT POINT TO ONE ANOTHER IN A CLOCKWISE MANNER TO INDICATE A PARTIALLY ENCLOSED SPACE, AND WHERE ONE OF THE ARROWS FORMS A STYLIZED "M" OR MOUNTAIN SHAPE.

FOR BEER (U.S. CLS. 45, 46 AND 48).
JUSTINE D. PARKER, EXAMINING ATTORNEY

SN 85-517,293. MULTI-FLOW INDUSTRIES LP, HUNTINGDON VALLEY, PA. FILED 1-16-2012.



NO CLAIM IS MADE TO THE EXCLUSIVE RIGHT TO USE "COLA", APART FROM THE MARK AS SHOWN.

THE MARK CONSISTS OF THE STYLIZED WORDING "KODIAK BIG-BOLD-PURE COLA" AND BEAR DESIGN. THE DESIGN SHOWS THE HEAD, SHOULDERS AND FRONT PAW OF A FRONT-FACING SNARLING BEAR WITHIN A ROUNDED CORNER RECTANGLE, WITH A PORTION OF THE BEAR COVERING AND EXTENDING OUT FROM THE TOP OF THE RECTANGLE. A MOUNTAIN-SKY SCENE APPEARS IN THE LEFT UPPER CORNER OF THE RECTANGLE. DIRECTLY UNDERNEATH THE BEAR AND PARTIALLY COVERED BY THE CLAWS ON THE PAW IS THE WORD "KODIAK", THE UPPER PORTION OF WHICH IS OUTLINED, THE LOWER PORTION OF WHICH APPEARS TO BE OBSCURED BY SNOW MOUNDS. UNDERNEATH "KODIAK" AND WITHIN THE RECTANGLE APPEARS THE WORDING "BIG-BOLD-PURE COLA" WITH THE LAST WORD LARGER IN SCALE.

FOR COLA. COLA-BASED PREPARATIONS AND BEVERAGES, NAMELY, COLA BASED MIXES IN THE NATURE OF CONCENTRATES AND SYRUPS (U.S. CLS. 45, 46 AND 48).

FIRST USE 5-2-2011; IN COMMERCE 5-2-2011.
LINDA E. BLOHM, EXAMINING ATTORNEY

CLASS 33—WINES AND SPIRITS

SN 77-833,937. TRIVENTO BODEGAS Y VINEDOS S.A., MENDOZA, ARGENTINA, FILED 9-24-2009.

TRIVENTO EOLO

THE MARK CONSISTS OF STANDARD CHARACTERS WITHOUT CLAIM TO ANY PARTICULAR FONT, STYLE, SIZE, OR COLOR.

THE ENGLISH TRANSLATION OF "EOLO" IN THE MARK IS AEOLUS. THE WORDING "TRIVENTO" HAS NO MEANING IN A FOREIGN LANGUAGE.

FOR WINE (U.S. CLS. 47 AND 49).
FIRST USE 6-30-2008; IN COMMERCE 6-30-2008.
LAURIE MAYES, EXAMINING ATTORNEY

SN 77-965,360. CULTIVE, INC., DAVIS, CA. FILED 3-22-2010.

CULTIVÉ CELLARS

THE MARK CONSISTS OF STANDARD CHARACTERS WITHOUT CLAIM TO ANY PARTICULAR FONT, STYLE, SIZE, OR COLOR.

OWNER OF U.S. REG. NO. 3,745,197.

NO CLAIM IS MADE TO THE EXCLUSIVE RIGHT TO USE "CELLARS", APART FROM THE MARK AS SHOWN.

THE ENGLISH TRANSLATION OF "CULTIVÉ" IN THE MARK IS "CULTIVATED".

FOR ALCOHOLIC BEVERAGES, NAMELY, WINES (U.S. CLS. 47 AND 49).

WILLIAM BRECKENFELD, EXAMINING ATTORNEY

SN 79-091,398. CAVAS DEL AMPURDAN, S.A., SPAIN, FILED 11-18-2010.

BLANC PESCADOR

THE MARK CONSISTS OF STANDARD CHARACTERS WITHOUT CLAIM TO ANY PARTICULAR FONT, STYLE, SIZE, OR COLOR.

OWNER OF INTERNATIONAL REGISTRATION 1062058 DATED 11-18-2010, EXPIRES 11-18-2020.

NO CLAIM IS MADE TO THE EXCLUSIVE RIGHT TO USE "BLANC", APART FROM THE MARK AS SHOWN.

THE ENGLISH TRANSLATION OF "BLANC" IN THE MARK IS "WHITE". THE ENGLISH TRANSLATION OF "PESCADOR" IN THE MARK IS "FISHERMAN".

FOR WHITE WINES AND SPARKLING WINES (U.S. CLS. 47 AND 49).

MICHELLE DUBOIS, EXAMINING ATTORNEY

CLASS 33—(Continued).

SN 79-092,757. GFA CHATEAU DE PRESSAC, FRANCE, FILED 1-20-2011.

CHATEAU TOUR DE PRESSAC

THE MARK CONSISTS OF STANDARD CHARACTERS WITHOUT CLAIM TO ANY PARTICULAR FONT, STYLE, SIZE, OR COLOR.

OWNER OF INTERNATIONAL REGISTRATION 1065675 DATED 1-20-2011, EXPIRES 1-20-2021.

OWNER OF U.S. REG. NO. 2,920,600.

NO CLAIM IS MADE TO THE EXCLUSIVE RIGHT TO USE "CHATEAU" OR "PRESSAC", APART FROM THE MARK AS SHOWN.

THE ENGLISH TRANSLATION OF THE WORDS "CHATEAU TOUR DE PRESSAC" IN THE MARK IS "CASTLE TOWER OF PRESSAC".

FOR AOC WINES (WINES WITH PROTECTED APPELLATION OF ORIGIN) FROM THE WINE-MAKING ESTATE CALLED "CHATEAU TOUR DE PRESSAC" (U.S. CLS. 47 AND 49).

BRIAN PINO, EXAMINING ATTORNEY

CLASS 33—(Continued).

SN 79-098,911. CHIVAS HOLDINGS (IP) LIMITED, UNITED KINGDOM, FILED 4-26-2011.



PRIORITY DATE OF 2-15-2011 IS CLAIMED. OWNER OF INTERNATIONAL REGISTRATION 1081428 DATED 4-26-2011, EXPIRES 4-26-2021.

THE MARK CONSISTS OF THE STYLIZED DESIGN OF A LION IN A RECTANGULAR SHAPED DESIGN. FOR ALCOHOLIC BEVERAGES EXCEPT BEERS (U.S. CLS. 47 AND 49).

WILLIAM ROSSMAN, EXAMINING ATTORNEY

SN 79-098,768. EXPLOITATION VINICOLE BENJAMIN DE ROTHSCHILD, FRANCE, FILED 4-22-2011.

CHATEAU DES LAURETS
Appellation Puisseguin Saint Emilion Contrôlée

THE MARK CONSISTS OF STANDARD CHARACTERS WITHOUT CLAIM TO ANY PARTICULAR FONT, STYLE, SIZE, OR COLOR.

OWNER OF INTERNATIONAL REGISTRATION 1081008 DATED 4-22-2011, EXPIRES 4-22-2021.

NO CLAIM IS MADE TO THE EXCLUSIVE RIGHT TO USE "CHATEAU" OR "APPELLATION PUISSEGUIN SAINT EMILION CONTROLEE", APART FROM THE MARK AS SHOWN.

THE ENGLISH TRANSLATION OF "CHATEAU DES LAURETS APPELLATION PUISSEGUIN SAINT EMILION CONTROLEE" IN THE MARK IS "CASTLE OF LAURETS REGISTERED DESIGNATION OF ORIGIN PUISSEGUIN SAINT EMILION".

FOR WINES, NAMELY, AOC WINES, WINES WITH PROTECTED APPELLATION OF ORIGIN (U.S. CLS. 47 AND 49).

KATHERINE CONNOLLY, EXAMINING ATTORNEY

SN 79-098,912. CHIVAS HOLDINGS (IP) LIMITED, UNITED KINGDOM, FILED 4-26-2011.

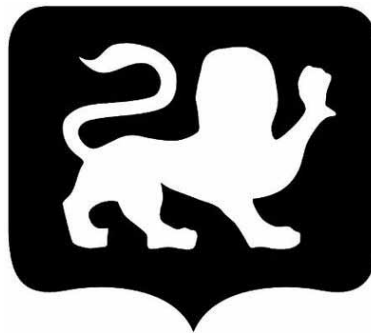

PRIORITY DATE OF 2-15-2011 IS CLAIMED. OWNER OF INTERNATIONAL REGISTRATION 1081429 DATED 4-26-2011, EXPIRES 4-26-2021.

THE MARK CONSISTS OF THE STYLIZED DESIGN OF A LION IN A RECTANGULAR SHAPED DESIGN. FOR ALCOHOLIC BEVERAGES EXCEPT BEERS (U.S. CLS. 47 AND 49).

WILLIAM ROSSMAN, EXAMINING ATTORNEY

CLASS 33—(Continued).

SN 79-099,027. SOCIEDAD VINÍCOLA MIGUEL TORRES S.A., CHILE, FILED 5-19-2011.

HEMISFERIO

THE MARK CONSISTS OF STANDARD CHARACTERS WITHOUT CLAIM TO ANY PARTICULAR FONT, STYLE, SIZE, OR COLOR.

OWNER OF INTERNATIONAL REGISTRATION 1081715 DATED 5-19-2011, EXPIRES 5-19-2021.

OWNER OF U.S. REG. NO. 2,933,508.

THE ENGLISH TRANSLATION OF THE FOREIGN WORD(S) IN THE MARK IS "HEMISPHERE".

FOR ALCOHOLIC BEVERAGES EXCEPT BEERS (U.S. CLS. 47 AND 49).

DOMINIC FATHY, EXAMINING ATTORNEY

SN 79-099,204. I SODI SOCIETA' AGRICOLA S.R.L., ITALY, FILED 5-19-2011.



OWNER OF INTERNATIONAL REGISTRATION 1082241 DATED 5-19-2011, EXPIRES 5-19-2021.

THE MARK CONSISTS OF THE WORD "I SODI" RISING ABOVE AN ARMORIAL BEARINGS CONSISTING OF A SHIELD SUBDIVIDED IN TWO SUPERIMPOSED PARTS THROUGH A DOUBLE HORIZONTAL LINE; IN THE UPPER PART OF SAID SHIELD THERE ARE TWO STARS AND IN THE LOWER PART THERE IS ONE STAR.

FOR ALCOHOLIC BEVERAGES EXCEPT BEERS (U.S. CLS. 47 AND 49).

KIMBERLY PERRY, EXAMINING ATTORNEY

SN 79-100,120. MARCHESI DE' FRESCOBALDI SOCIETA' AGRICOLA S.R.L., ITALY, FILED 4-22-2011.



PRIORITY DATE OF 1-26-2011 IS CLAIMED. OWNER OF INTERNATIONAL REGISTRATION 1084439 DATED 4-22-2011, EXPIRES 4-22-2021.

THE MARK CONSISTS OF THE TERMS "TERRE" AND "MORE" SEPARATED BY A DIAMOND DESIGN CONTAINING A WAVY LINE. UNDERNEATH ARE THE TERMS "DELL'AMMIRAGLIA".

THE ENGLISH TRANSLATION OF THE FOREIGN WORD(S) IN THE MARK IS: "DARK LANDS OF THE FEMALE ADMIRAL".

FOR WINES (U.S. CLS. 47 AND 49).

JANICE L. MCMORROW, EXAMINING ATTORNEY

CLASS 33—(Continued).

SN 79-100,122. MARCHESI DE' FRESCOBALDI SOCIETA' AGRICOLA S.R.L., ITALY, FILED 4-22-2011.

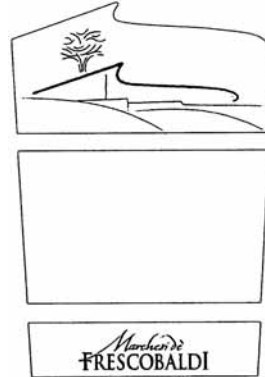

PRIORITY DATE OF 1-26-2011 IS CLAIMED.

OWNER OF INTERNATIONAL REGISTRATION 1084441 DATED 4-22-2011, EXPIRES 4-22-2021.

OWNER OF U.S. REG. NOS. 1,109,623 AND 3,427,022.

THE MARK CONSISTS OF A THREE PART LABEL DESIGN. THE TOP THIRD HAS A RECTANGULAR BOTTOM AND A WAVE DESIGN ON TOP, AND CONTAINS A TREE DESIGN, AND ANOTHER WAVE DESIGN. THE MIDDLE THIRD IS QUADRILATERAL. THE BOTTOM OF THE THREE IS A SMALLER RECTANGLE, AND CONTAINS THE TERMS "MARCHESI DE' FRESCOBALDI".

THE ENGLISH TRANSLATION OF "MARCHESI DE' FRESCOBALDI" IN THE MARK IS "THE FRESCOBALDI MARQUISES".

FOR WINES (U.S. CLS. 47 AND 49).

JANICE L. MCMORROW, EXAMINING ATTORNEY

SN 79-100,529. "ALCONOST" LIMITED LIABILITY COMPANY, RUSSIAN FED., FILED 5-27-2011.



АЛКОНОСТ

OWNER OF INTERNATIONAL REGISTRATION 1085434 DATED 5-27-2011, EXPIRES 5-27-2021.

THE MARK CONSISTS OF A DESIGN OF A HIGHLY STYLIZED BIRD FIGURE WITH A HUMAN FACE AND LONG HAIR WEARING A CROWN; BENEATH THIS DESIGN ARE CYRILLIC CHARACTERS WHICH TRANSLITERATE TO "ALCONOST".

THE NON-LATIN CHARACTERS IN THE MARK TRANSLITERATE TO "ALCONOST" AND THIS MEANS "ALCONOST" IN ENGLISH.

FOR VODKA (U.S. CLS. 47 AND 49).

BENJAMIN OKEKE, EXAMINING ATTORNEY

CLASS 33—(Continued).

SN 79-100,870. CENTRE VINICOLE CHAMPAGNE NICOLAS FEUILLATTE, UNION DE COOPERATIVES AGRICOLES, FRANCE, FILED 7-8-2011.

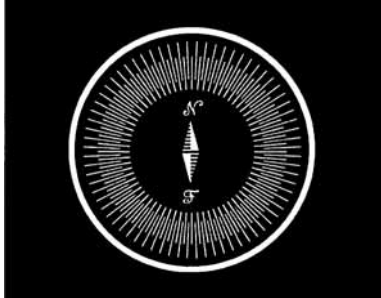

PRIORITY DATE OF 1-20-2011 IS CLAIMED.
OWNER OF INTERNATIONAL REGISTRATION 1086243 DATED 7-8-2011, EXPIRES 7-8-2021.
THE MARK CONSISTS OF A CIRCULAR DIAL WITH RADIATING LINES WITHIN AND TWO STYLIZED ARROWS POINTED UP AND DOWN WITH THE LETTER "N" FACING THE UPWARD ARROW AND THE LETTER "F" FACING THE DOWNWARD ARROW.
FOR ALCOHOLIC BEVERAGES, EXCEPT BEER (U.S. CLS. 47 AND 49).
JACLYN KIDWELL WALKER, EXAMINING ATTORNEY

SN 79-105,342. FRATELLI AVERNA S.P.A., ITALY, FILED 3-4-2011.

FRATTINA

OWNER OF INTERNATIONAL REGISTRATION 0539584 DATED 7-3-1989, EXPIRES 7-3-2019.
THE MARK CONSISTS OF THE STYLIZED WORD "FRATTINA".
FOR WINES, DISTILLED SPIRITS AND DISTILLED LIQUORS (U.S. CLS. 47 AND 49).
KELLEY WELLS, EXAMINING ATTORNEY

SN 79-106,020. VINICOLA DECORDI DEL BORGO IMPERIALE -; CORTESOLE S.P.A., ITALY, FILED 10-27-2011.

SARSITANO

THE MARK CONSISTS OF STANDARD CHARACTERS WITHOUT CLAIM TO ANY PARTICULAR FONT, STYLE, SIZE, OR COLOR.
PRIORITY DATE OF 10-25-2011 IS CLAIMED.
OWNER OF INTERNATIONAL REGISTRATION 1098831 DATED 10-27-2011, EXPIRES 10-27-2021.
FOR ALCOHOLIC BEVERAGES EXCEPT BEERS (U.S. CLS. 47 AND 49).
SHAILA SETTLES, EXAMINING ATTORNEY

CLASS 33—(Continued).

SN 79-107,587. TESCO STORES LIMITED, UNITED KINGDOM, FILED 11-24-2011.

LOCHLAN

THE MARK CONSISTS OF STANDARD CHARACTERS WITHOUT CLAIM TO ANY PARTICULAR FONT, STYLE, SIZE, OR COLOR.
PRIORITY DATE OF 5-27-2011 IS CLAIMED.
OWNER OF INTERNATIONAL REGISTRATION 1102686 DATED 11-24-2011, EXPIRES 11-24-2021.
FOR ALCOHOLIC BEVERAGES (EXCEPT BEERS) (U.S. CLS. 47 AND 49).
TARA PATE, EXAMINING ATTORNEY

SN 85-070,462. TKG BENNETT VALLEY, LLC, SAN FRANCISCO, CA. FILED 6-24-2010.

PAVO

THE MARK CONSISTS OF STANDARD CHARACTERS WITHOUT CLAIM TO ANY PARTICULAR FONT, STYLE, SIZE, OR COLOR.
THE ENGLISH TRANSLATION OF "PAVO" IN THE MARK IS "TURKEY".
FOR WINE (U.S. CLS. 47 AND 49).
FIRST USE 6-30-2009; IN COMMERCE 6-30-2009.
BILL DAWE, EXAMINING ATTORNEY

SN 85-194,819. WINE ADVENTURE TV, LLC, MIAMI, FL. FILED 12-10-2010.

BOTTERO

THE MARK CONSISTS OF STANDARD CHARACTERS WITHOUT CLAIM TO ANY PARTICULAR FONT, STYLE, SIZE, OR COLOR.
FOR WINE (U.S. CLS. 47 AND 49).
MARK PILARO, EXAMINING ATTORNEY

CLASS 33—(Continued).

SN 85-219,481. PRECEPT BRANDS, LLC, SEATTLE, WA.
FILED 1-18-2011.

CLASS 33—(Continued).

SN 85-268,760. THE ABSOLUT COMPANY AKTIEBOLAG,
STOCKHOLM, SWEDEN, FILED 3-16-2011.

CHOCOLATIER

THE MARK CONSISTS OF STANDARD CHARACTERS
WITHOUT CLAIM TO ANY PARTICULAR FONT, STYLE,
SIZE, OR COLOR.

FOR WINE (U.S. CLS. 47 AND 49).
FIRST USE 1-3-2011; IN COMMERCE 1-3-2011.
JOHN DWYER, EXAMINING ATTORNEY



SN 85-238,920. HOLT'S COMPANY, WILMINGTON, DE.
FILED 2-10-2011.

ASHTON

THE MARK CONSISTS OF STANDARD CHARACTERS
WITHOUT CLAIM TO ANY PARTICULAR FONT, STYLE,
SIZE, OR COLOR.

OWNER OF U.S. REG. NOS. 1,376,628, 2,639,893 AND
OTHERS.

SEC. 2(F).
FOR LIQUOR, NAMELY, ALCOHOLIC BEVERAGES
PRODUCED FROM A BREWED MALT BASE, ALCO-
HOLIC COFFEE-BASED BEVERAGES, ALCOHOLIC
MALT COOLERS, ALCOHOLIC PUNCH, BRANDY,
BRANDY SPIRITS, GIN, RUM, SCOTCH, TEQUILA,
VODKA, WINE, WHISKEY (U.S. CLS. 47 AND 49).
ZACHARY BELLO, EXAMINING ATTORNEY

PRIORITY CLAIMED UNDER SEC. 44(D) ON ERP
CMNTY TM OFC APPLICATION NO. 009814807, FILED 3-
16-2011, REG. NO. 009814807, DATED 7-27-2011, EXPIRES 3-
16-2021.

OWNER OF U.S. REG. NOS. 1,893,279, 3,309,725 AND
OTHERS.

NO CLAIM IS MADE TO THE EXCLUSIVE RIGHT TO
USE "VODKA", APART FROM THE MARK AS SHOWN.

THE COLOR(S) BLACK AND BLUE IS/ARE CLAIMED AS
A FEATURE OF THE MARK.

THE MARK CONSISTS OF THE BLUE WORD "ABSO-
LUT" ABOVE THE BLACK WORDS "COUNTRY OF SWE-
DEN" ABOVE THE BLUE WORD "VODKA".

THE ENGLISH TRANSLATION OF "ABSOLUT" IN THE
MARK IS "ABSOLUTE".

SEC. 2(F) AS TO "COUNTRY OF SWEDEN".
FOR ALCOHOLIC BEVERAGES EXCEPT BEERS (U.S.
CLS. 47 AND 49).
LINDA LAVACHE, EXAMINING ATTORNEY

CLASS 33—(Continued).

SN 85-268,788. THE ABSOLUT COMPANY AKTIEBOLAG, STOCKHOLM, SWEDEN, FILED 3-16-2011.

ABSOLUT
Country of Sweden
VODKA

*Every drop of this
superb vodka has been crafted
only with Swedish winter wheat
near the small town of Åhus
and continues a determined
commitment to the pursuit of
perfection since 1879.*

PRIORITY CLAIMED UNDER SEC. 44(D) ON ERP N CMNTY TM OFC APPLICATION NO. 009814849, FILED 3-16-2011, REG. NO. 009814849, DATED 7-27-2011, EXPIRES 3-16-2021.

OWNER OF U.S. REG. NOS. 1,893,279, 3,309,725 AND OTHERS.

NO CLAIM IS MADE TO THE EXCLUSIVE RIGHT TO USE "VODKA", APART FROM THE MARK AS SHOWN.

THE COLOR(S) BLACK AND BLUE IS/ARE CLAIMED AS A FEATURE OF THE MARK.

THE MARK CONSISTS OF THE BLUE WORD "ABSOLUT" ABOVE THE BLACK WORDS "COUNTRY OF SWEDEN" ABOVE THE BLUE WORD "VODKA", ALL OF WHICH IS ABOVE THE BLACK WORDING "EVERY DROP OF THIS SUPERB VODKA HAS BEEN CRAFTED ONLY WITH SWEDISH WINTER WHEAT NEAR THE SMALL TOWN OF ÅHUS AND CONTINUES A DETERMINED COMMITMENT TO THE PURSUIT OF PERFECTION SINCE 1879."

THE ENGLISH TRANSLATION OF "ABSOLUT" IN THE MARK IS "ABSOLUTE".

SEC. 2(F) AS TO "COUNTRY OF SWEDEN".
FOR ALCOHOLIC BEVERAGES EXCEPT BEERS (U.S. CLS. 47 AND 49).

LINDA LAVACHE, EXAMINING ATTORNEY

SN 85-294,589. KING ESTATE WINERY LIMITED PARTNERSHIP, EUGENE, OR. FILED 4-13-2011.



NO CLAIM IS MADE TO THE EXCLUSIVE RIGHT TO USE THE DESIGN OF THE QUICK RESPONSE CODES, APART FROM THE MARK AS SHOWN.

THE MARK CONSISTS OF A STYLIZED DRAWING OF FOUR WINE BOTTLES, WITH LABELS CONSISTING OF QUICK RESPONSE CODE DESIGNS, ON A SHELF AND THE PROFILE OF A WOMAN SCANNING ONE OF THE LABELS WITH A HANDHELD DEVICE.

FOR WINE (U.S. CLS. 47 AND 49).
COLLEEN KEARNEY, EXAMINING ATTORNEY

CLASS 33—(Continued).

SN 85-298,845. 750 ML, LLC, MILFORD, DE. FILED 4-19-2011.

HARD NUTS

THE MARK CONSISTS OF STANDARD CHARACTERS WITHOUT CLAIM TO ANY PARTICULAR FONT, STYLE, SIZE, OR COLOR.

NO CLAIM IS MADE TO THE EXCLUSIVE RIGHT TO USE "NUTS", APART FROM THE MARK AS SHOWN.

FOR ALCOHOLIC BEVERAGES EXCEPT BEERS (U.S. CLS. 47 AND 49).

EUGENIA MARTIN, EXAMINING ATTORNEY

SN 85-299,750. 750 ML, LLC, MILFORD, DE. FILED 4-20-2011.

CHALMONT

THE MARK CONSISTS OF STANDARD CHARACTERS WITHOUT CLAIM TO ANY PARTICULAR FONT, STYLE, SIZE, OR COLOR.

FOR ALCOHOLIC BEVERAGES EXCEPT BEERS (U.S. CLS. 47 AND 49).

EUGENIA MARTIN, EXAMINING ATTORNEY

SN 85-302,712. HERNANDEZ FLORES, ALEJANDRO, PROVIDENCIA, SANTIAGO, CHILE, FILED 4-22-2011.

ALTO ANDINO

THE MARK CONSISTS OF STANDARD CHARACTERS WITHOUT CLAIM TO ANY PARTICULAR FONT, STYLE, SIZE, OR COLOR.

THE ENGLISH TRANSLATION OF "ALTO ANDINO" IN THE MARK IS "HIGH ANDEAN".

FOR WINES (U.S. CLS. 47 AND 49).
BRIDGETT SMITH, EXAMINING ATTORNEY

CLASS 33—(Continued).

SN 85-323,719. CEJA VINEYARDS, INC., NAPA, CA. FILED 5-18-2011.

CEJA VINEYARDS

THE MARK CONSISTS OF STANDARD CHARACTERS WITHOUT CLAIM TO ANY PARTICULAR FONT, STYLE, SIZE, OR COLOR.

OWNER OF U.S. REG. NO. 3,414,209.

NO CLAIM IS MADE TO THE EXCLUSIVE RIGHT TO USE "VINEYARDS", APART FROM THE MARK AS SHOWN.

FOR WINE (U.S. CLS. 47 AND 49).

FIRST USE 5-0-2001; IN COMMERCE 5-0-2001.

HEATHER BIDDULPH, EXAMINING ATTORNEY

SN 85-328,009. XV EXCLUSIVES, INC, MONTCLAIR, NJ. FILED 5-23-2011.

TMRW

THE MARK CONSISTS OF STANDARD CHARACTERS WITHOUT CLAIM TO ANY PARTICULAR FONT, STYLE, SIZE, OR COLOR.

FOR WINES (U.S. CLS. 47 AND 49).

FIRST USE 4-8-2011; IN COMMERCE 4-8-2011.

STEPHANIE ALI, EXAMINING ATTORNEY

CLASS 33—(Continued).

SN 85-338,888. BOHAE BREWERY CO., LTD, JEOLLANAM, REPUBLIC OF KOREA, FILED 6-6-2011.



NO CLAIM IS MADE TO THE EXCLUSIVE RIGHT TO USE THE NON-LATIN CHARACTERS THAT TRANSLITERATE TO "MAKGEOLLI", APART FROM THE MARK AS SHOWN.

THE COLOR(S) RED, WHITE AND BLACK IS/ARE CLAIMED AS A FEATURE OF THE MARK.

THE MARK CONSISTS OF WHITE CHINESE CHARACTERS IN A PORTION OF A RED SPHERE, BLACK KOREAN CHARACTERS, RED KOREAN CHARACTERS OUTLINED BY A RED SQUARE, THE WORDS "SOONY MAKGEOLLI" FOLLOWED BY A RED CUP AND BOTTLE.

THE WORDING "SOONY" HAS NO MEANING IN A FOREIGN LANGUAGE.

THE NON-LATIN CHARACTERS IN THE MARK TRANSLITERATE TO "MAKGEOLLI" AND THIS MEANS "KOREAN TRADITIONAL RICE WINE" IN ENGLISH. THE NON-LATIN CHARACTERS IN THE MARK TRANSLITERATE TO "SOONY" AND THIS HAS NO MEANING IN A FOREIGN LANGUAGE.

FOR SOJU (KOREAN DISTILLED LIQUOR); SAKE; TAG-JU (UNSTRAINED RICE WINE); LIQUEURS; JAPANESE APRICOT LIQUOR; SPARKLING FRUIT WINE; ALCOHOLIC BEVERAGE CONTAINING FRUIT; WHISKY; YAKYONGJU (MEDICINAL ALCOHOLIC BEVERAGES); ACANTHOPANAX WINE (CHINESE LIQUEURS); MAKGEOLLI (KOREAN TRADITIONAL RICE WINE) (U.S. CLS. 47 AND 49).

PAM WILLIS, EXAMINING ATTORNEY

SN 85-339,180. LARSON FAMILY WINERY, INC., SONOMA, CA. FILED 6-6-2011.

Larson Family Winery

THE MARK CONSISTS OF STANDARD CHARACTERS WITHOUT CLAIM TO ANY PARTICULAR FONT, STYLE, SIZE, OR COLOR.

NO CLAIM IS MADE TO THE EXCLUSIVE RIGHT TO USE "FAMILY WINERY", APART FROM THE MARK AS SHOWN.

SEC. 2(F).

FOR WINE (U.S. CLS. 47 AND 49).

FIRST USE 12-11-2003; IN COMMERCE 12-11-2003.

HEATHER THOMPSON, EXAMINING ATTORNEY

CLASS 33—(Continued).

SN 85-346,050. KVV INTELLECTUAL PROPERTIES (PTY) LIMITED, PAARL 7624, SOUTH AFRICA, FILED 6-14-2011.



OWNER OF U.S. REG. NO. 3,389,899.
NO CLAIM IS MADE TO THE EXCLUSIVE RIGHT TO USE "AFRICA", APART FROM THE MARK AS SHOWN.
THE MARK CONSISTS OF "WILD AFRICA" ABOVE A PHOTOGRAPHIC IMAGE OF A LEOPARD'S HEAD ALL DISPLAYED WITHIN A SHIELD DESIGN. THE GRAY IN THE MARK INDICATES SHADING AND COLOR IS NOT CLAIMED AS A FEATURE OF THE MARK.
FOR LIQUEURS (U.S. CLS. 47 AND 49).
CHRIS WELLS, EXAMINING ATTORNEY

SN 85-349,586. LOLA'S LIBATIONS, LLC, COLLEYVILLE, TX. FILED 6-17-2011.

SMARTINI

THE MARK CONSISTS OF STANDARD CHARACTERS WITHOUT CLAIM TO ANY PARTICULAR FONT, STYLE, SIZE, OR COLOR.
FOR PREPARED ALCOHOLIC COCKTAIL MIXES (U.S. CLS. 47 AND 49).
DOMINIC FATHY, EXAMINING ATTORNEY

CLASS 33—(Continued).

SN 85-354,128. A&B ESTATE WINES LLC, FORESTVILLE, CA. FILED 6-23-2011.

WINE GUERRILLA

NO CLAIM IS MADE TO THE EXCLUSIVE RIGHT TO USE "WINE", APART FROM THE MARK AS SHOWN.
THE MARK CONSISTS OF THE STYLIZED TEXT "WINE GUERRILLA".
FOR WINES (U.S. CLS. 47 AND 49).
FIRST USE 1-1-2000, THE MARK WAS FIRST USED ANYWHERE IN A DIFFERENT FORM OTHER THAN THAT SOUGHT TO BE REGISTERED AT LEAST AS EARLY AS 01/01/2000.; IN COMMERCE 1-1-2006, THE MARK WAS FIRST USED IN COMMERCE IN A DIFFERENT FORM OTHER THAN THAT SOUGHT TO BE REGISTERED AT LEAST AS EARLY AS 02/03/2006..
BRENDAN REGAN, EXAMINING ATTORNEY

SN 85-363,881. THE ABSOLUT COMPANY AKTIEBOLAG, STOCKHOLM, SWEDEN, FILED 7-6-2011.

PRIORITY CLAIMED UNDER SEC. 44(D) ON ERPNCMNTY TM OFC APPLICATION NO. 010076701, FILED 6-27-2011, REG. NO. 010076701, DATED 11-7-2011, EXPIRES 11-7-2021.
OWNER OF U.S. REG. NOS. 1,893,279, 3,309,725 AND OTHERS.
THE MARK CONSISTS OF THE WORDING "ABSOLUT GRÄPEVINE" IN BOLD STYLIZED LETTERING WITH THE WORDING "COUNTRY OF SWEDEN" IN BETWEEN IN CURSIVE SCRIPT.
THE ENGLISH TRANSLATION OF "ABSOLUT" IN THE MARK IS "ABSOLUTE".
SEC. 2(F) AS TO "COUNTRY OF SWEDEN".
FOR ALCOHOLIC BEVERAGES EXCEPT BEERS OR WINES (U.S. CLS. 47 AND 49).
ZHALEH DELANEY, EXAMINING ATTORNEY

CLASS 33—(Continued).

SN 85-413,627. SOUTHERN WINE GROUP, LLC, DBA ERMISCH FAMILY CELLARS, BEND, OR. FILED 9-1-2011.

CLASS 33—(Continued).

SN 85-425,083. FRIEDMAN, ANDREW BENJAMIN, SEATTLE, WA. FILED 9-16-2011.

Erendira

323

THE MARK CONSISTS OF STANDARD CHARACTERS WITHOUT CLAIM TO ANY PARTICULAR FONT, STYLE, SIZE, OR COLOR.
THE WORDING "ERENDIRA" HAS NO MEANING IN A FOREIGN LANGUAGE.
FOR RED TABLE WINE (U.S. CLS. 47 AND 49).
FIRST USE 9-1-2011; IN COMMERCE 9-1-2011.
KELLY CHOE, EXAMINING ATTORNEY

THE MARK CONSISTS OF STANDARD CHARACTERS WITHOUT CLAIM TO ANY PARTICULAR FONT, STYLE, SIZE, OR COLOR.
FOR ALCOHOLIC BEVERAGES EXCEPT BEERS; DISTILLED SPIRITS; SPIRITS AND LIQUEURS; VODKA (U.S. CLS. 47 AND 49).
JOHN E. MICHOS, EXAMINING ATTORNEY

SN 85-415,264. KEYSTONE LIBATION COMPANY, LLC, PHILADELPHIA, PA. FILED 9-6-2011.

Spodee & Sody!

THE MARK CONSISTS OF STANDARD CHARACTERS WITHOUT CLAIM TO ANY PARTICULAR FONT, STYLE, SIZE, OR COLOR.
FOR WINES AND FORTIFIED WINES (U.S. CLS. 47 AND 49).
JEAN IM, EXAMINING ATTORNEY

SN 85-425,166. FRIEDMAN, ANDREW BENJAMIN, SEATTLE, WA. FILED 9-16-2011.

SN 85-421,078. MCGOWAN CRAIN, LLC, SAINT LOUIS, MO. FILED 9-13-2011.

404

Black Mamba

THE MARK CONSISTS OF STANDARD CHARACTERS WITHOUT CLAIM TO ANY PARTICULAR FONT, STYLE, SIZE, OR COLOR.
FOR SPIRITS AND LIQUEURS (U.S. CLS. 47 AND 49).
MATTHEW PAPPAS, EXAMINING ATTORNEY

THE MARK CONSISTS OF STANDARD CHARACTERS WITHOUT CLAIM TO ANY PARTICULAR FONT, STYLE, SIZE, OR COLOR.
FOR ALCOHOLIC BEVERAGES EXCEPT BEERS; DISTILLED SPIRITS; SPIRITS AND LIQUEURS; VODKA (U.S. CLS. 47 AND 49).
JOHN E. MICHOS, EXAMINING ATTORNEY

CLASS 33—(Continued).

SN 85-428,765. CINQUE, GREGORY, MILLSTONE TOWNSHIP, NJ. AND COLUCCI, STEVEN, WESTHAMPTON BEACH, NY. FILED 9-21-2011.



NO CLAIM IS MADE TO THE EXCLUSIVE RIGHT TO USE "WINES", APART FROM THE MARK AS SHOWN.

THE NAME "COLUCCI" IDENTIFIES A LIVING INDIVIDUAL WHOSE CONSENT IS OF RECORD.

THE COLOR(S) BLUE, GREEN, RED, BLACK, WHITE AND PEACH IS/ARE CLAIMED AS A FEATURE OF THE MARK.

THE MARK CONSISTS OF A MINIATURE MAN WITH A RED HAT, TIE AND SHOES, PEACH SKIN, WHITE SHIRT, GREEN JACKET AND BLUE PANTS AND THREE BLACK VERTICAL BARS WITH THE STYLIZED BLACK TEXT "COLUCCI" APPEARING TO THE RIGHT; THE BLACK STYLIZED WORDING "SURLY BEAST" APPEARS ABOVE HIM AND UNDERNEATH THE MAN IS THE STYLIZED BLACK TEXT "WINES".

FOR WINE (U.S. CLS. 47 AND 49).

TRICIA SONNEBORN, EXAMINING ATTORNEY

SN 85-432,944. VIÑA DOÑA PAULA S.A., MENDOZA, ARGENTINA, FILED 9-27-2011.

DOÑA PAULA PARCEL SELECTION

THE MARK CONSISTS OF STANDARD CHARACTERS WITHOUT CLAIM TO ANY PARTICULAR FONT, STYLE, SIZE, OR COLOR.

OWNER OF U.S. REG. NOS. 3,737,927 AND 4,020,283.

NO CLAIM IS MADE TO THE EXCLUSIVE RIGHT TO USE "PARCEL SELECTION", APART FROM THE MARK AS SHOWN.

THE NAME(S), PORTRAIT(S), AND/OR SIGNATURE(S) SHOWN IN THE MARK DOES NOT IDENTIFY A PARTICULAR LIVING INDIVIDUAL.

THE ENGLISH TRANSLATION OF "DOÑA PAULA" IN THE MARK IS "MRS. PAULA" OR "LADY PAULA".

FOR WINES (U.S. CLS. 47 AND 49).

CURTIS FRENCH, EXAMINING ATTORNEY

CLASS 33—(Continued).

SN 85-437,062. TEQUILERA RH, SA DE CV, DBA TEQUILERA RH, SA DE CV, GUADALAJARA, JALISCO, MEXICO, FILED 9-30-2011.

R&H INTENSO

THE MARK CONSISTS OF STANDARD CHARACTERS WITHOUT CLAIM TO ANY PARTICULAR FONT, STYLE, SIZE, OR COLOR.

OWNER OF U.S. REG. NO. 4,068,419.

THE ENGLISH TRANSLATION OF "R&H INTENSO" IN THE MARK IS "R&H INTENSE". THE WORDING "R&H" HAS NO MEANING IN A FOREIGN LANGUAGE.

FOR TEQUILA (U.S. CLS. 47 AND 49).

IRA J. GOODSAY, EXAMINING ATTORNEY

SN 85-437,411. SAZERAC COMPANY, INC., METAIRIE, LA. FILED 10-3-2011.

CHATEAU POMARI

THE MARK CONSISTS OF STANDARD CHARACTERS WITHOUT CLAIM TO ANY PARTICULAR FONT, STYLE, SIZE, OR COLOR.

NO CLAIM IS MADE TO THE EXCLUSIVE RIGHT TO USE "CHATEAU", APART FROM THE MARK AS SHOWN.

THE ENGLISH TRANSLATION OF "CHATEAU" IN THE MARK IS "CASTLE" OR "MANOR HOUSE".

FOR LIQUEURS (U.S. CLS. 47 AND 49).

FIRST USE 10-0-2006; IN COMMERCE 10-0-2006.

KIMBERLY PERRY, EXAMINING ATTORNEY

SN 85-437,420. SAZERAC COMPANY, INC., METAIRIE, LA. FILED 10-3-2011.

PICCALA

THE MARK CONSISTS OF STANDARD CHARACTERS WITHOUT CLAIM TO ANY PARTICULAR FONT, STYLE, SIZE, OR COLOR.

THE WORDING "PICCALA" HAS NO MEANING IN A FOREIGN LANGUAGE.

FOR LIQUEURS (U.S. CLS. 47 AND 49).

FIRST USE 9-0-1988; IN COMMERCE 9-0-1988.

KIMBERLY PERRY, EXAMINING ATTORNEY

CLASS 33—(Continued).

SN 85-438,710. KAREN HAINES, DANA POINT, CA. FILED 10-4-2011.

LOW CALORIE HAS NEVER BEEN
SO STYLISH

THE MARK CONSISTS OF STANDARD CHARACTERS WITHOUT CLAIM TO ANY PARTICULAR FONT, STYLE, SIZE, OR COLOR.

FOR LOW CALORIE ALCOHOLIC BEVERAGES EXCEPT BEERS (U.S. CLS. 47 AND 49).
KAREN K. BUSH, EXAMINING ATTORNEY

SN 85-441,180. FELIX SOLIS, S.A., CIUDAD REAL, SPAIN, FILED 10-6-2011.

EL SANCHO ESCUDERO

THE MARK CONSISTS OF STANDARD CHARACTERS WITHOUT CLAIM TO ANY PARTICULAR FONT, STYLE, SIZE, OR COLOR.

THE ENGLISH TRANSLATION OF "EL" AND "ESCUDERO" IS "THE" AND "SHIELD BEARER".
FOR WINES (U.S. CLS. 47 AND 49).
ALEX KEAM, EXAMINING ATTORNEY

SN 85-442,036. CUMULUS CONCEPTS LLC, MAGNOLIA, TX. FILED 10-7-2011.

REAL MATLATL

THE MARK CONSISTS OF STANDARD CHARACTERS WITHOUT CLAIM TO ANY PARTICULAR FONT, STYLE, SIZE, OR COLOR.

THE WORDING "MATLATL" HAS NO MEANING IN A FOREIGN LANGUAGE.
FOR ALCOHOLIC BEVERAGES EXCEPT BEERS (U.S. CLS. 47 AND 49).
AMY KELLY, EXAMINING ATTORNEY

CLASS 33—(Continued).

SN 85-445,684. PATRICK AROFF, PACIFIC PALISADES, CA. FILED 10-12-2011.

Maui Hard Cider

THE MARK CONSISTS OF STANDARD CHARACTERS WITHOUT CLAIM TO ANY PARTICULAR FONT, STYLE, SIZE, OR COLOR.

NO CLAIM IS MADE TO THE EXCLUSIVE RIGHT TO USE "HARD CIDER", APART FROM THE MARK AS SHOWN.

FOR ALCOHOLIC BEVERAGE PRODUCED FROM A BREWED MALT BASE WITH NATURAL FLAVORS; ALCOHOLIC BEVERAGES CONTAINING FRUIT; ALCOHOLIC BEVERAGES OF FRUIT; ALCOHOLIC CARBONATED BEVERAGES, EXCEPT BEER; ALCOHOLIC FRUIT COCKTAIL DRINKS; ALCOHOLIC MALT COOLERS; ALCOHOLIC MIXED BEVERAGES EXCEPT BEERS; ALCOHOLIC PUNCH; FLAVORED BREWED MALT BEVERAGE; PREPARED ALCOHOLIC COCKTAIL; SAKE; SAKE; SPIRITS (U.S. CLS. 47 AND 49).
WILLIAM JACKSON, EXAMINING ATTORNEY

SN 85-445,930. EOLA HILLS WINE CELLARS, INC. RICK-REALL, OR. FILED 10-12-2011.

EOLA HILLS

THE MARK CONSISTS OF STANDARD CHARACTERS WITHOUT CLAIM TO ANY PARTICULAR FONT, STYLE, SIZE, OR COLOR.

SEC. 2(F).
FOR WINE (U.S. CLS. 47 AND 49).
FIRST USE 1-1-1990; IN COMMERCE 1-1-1990.
GRETTA YAO, EXAMINING ATTORNEY

SN 85-446,106. YEALANDS ESTATE WINES LIMITED, MARLBOROUGH, NEW ZEALAND, FILED 10-12-2011.

GRASMERE HEIGHTS

THE MARK CONSISTS OF STANDARD CHARACTERS WITHOUT CLAIM TO ANY PARTICULAR FONT, STYLE, SIZE, OR COLOR.

FOR WINE (U.S. CLS. 47 AND 49).
FIRST USE 2-8-2011; IN COMMERCE 2-8-2011.
HANNO RITTNER, EXAMINING ATTORNEY

CLASS 33—(Continued).

SN 85-446,417. GFY HOLDINGS, LLC, HARRAH, WA. FILED 10-13-2011.

WAR PONY

THE MARK CONSISTS OF STANDARD CHARACTERS WITHOUT CLAIM TO ANY PARTICULAR FONT, STYLE, SIZE, OR COLOR.

FOR ALCOHOLIC BEVERAGES, NAMELY, VODKA, WHISKEY AND GIN (U.S. CLS. 47 AND 49).
JORDAN BAKER, EXAMINING ATTORNEY

CLASS 33—(Continued).

SN 85-446,464. BOER HERITAGE HAUS, LTD., TA LIBERTY TREE WINERY, DOWNINGTOWN, PA. AND BOER, SETH NATHAN, DOWNINGTOWN, PA. AND BOER, APRIL KAY, DOWNINGTOWN, PA. FILED 10-13-2011.

Liberty Tree

THE MARK CONSISTS OF STANDARD CHARACTERS WITHOUT CLAIM TO ANY PARTICULAR FONT, STYLE, SIZE, OR COLOR.

FOR COOKING WINE; FRUIT WINE; GRAPE WINE; RED WINE; RED WINES; TABLE WINES; WHITE WINE; WINE; WINES (U.S. CLS. 47 AND 49).

CARYN GLASSER, EXAMINING ATTORNEY

SN 85-446,465. MOUNT GAY DISTILLERIES LIMITED, SAINT MICHAEL, BARBADOS, FILED 10-13-2011.

SN 85-446,420. KULETO VILLA, LLC, JACKSONVILLE, FL. FILED 10-13-2011.

INDIA INK

THE MARK CONSISTS OF STANDARD CHARACTERS WITHOUT CLAIM TO ANY PARTICULAR FONT, STYLE, SIZE, OR COLOR.

FOR WINES (U.S. CLS. 47 AND 49).
FIRST USE 3-0-2008; IN COMMERCE 3-0-2008.
BILL DAWE, EXAMINING ATTORNEY

SN 85-446,424. KULETO VILLA, LLC, JACKSONVILLE, GA. FILED 10-13-2011.

FROG PRINCE

THE MARK CONSISTS OF STANDARD CHARACTERS WITHOUT CLAIM TO ANY PARTICULAR FONT, STYLE, SIZE, OR COLOR.

FOR WINES (U.S. CLS. 47 AND 49).
FIRST USE 4-0-2010; IN COMMERCE 4-0-2010.
BILL DAWE, EXAMINING ATTORNEY

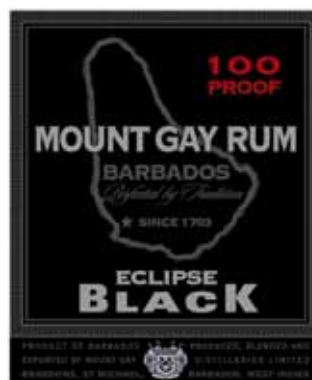

OWNER OF U.S. REG. NOS. 1,690,429, 3,602,534 AND OTHERS.

NO CLAIM IS MADE TO THE EXCLUSIVE RIGHT TO USE "100 PROOF", "RUM", "BARBADOS", "SINCE 1703", "BLACK", REPRESENTATION OF THE ISLAND OF BARBADOS, "PRODUCT OF BARBADOS", "PRODUCED, BLENDED AND EXPORTED BY", "DISTILLERIES LIMITED", "BRANDONS, ST MICHAEL", "BARBADOS, WEST INDIES, APART FROM THE MARK AS SHOWN.

THE COLOR(S) BLACK, GRAY, RED IS/ARE CLAIMED AS A FEATURE OF THE MARK.

THE MARK CONSISTS OF A BLACK RECTANGULAR FIELD WITH A BORDER SURROUNDING MOST OF THE UPPER PORTION OF THE FIELD, THE BORDER CONSISTING OF A GRAY LINE RECTANGLE SURROUNDED BY A DESIGN OF ALTERNATING BLACK AND GRAY LINES PERPENDICULAR TO THE BORDER; INSIDE THE BORDER IS A MAP OF BARBADOS IN DARK GRAY OUTLINE, AND THE FOLLOWING WORDING IN DARK GRAY: "BARBADOS PERFECTED BY TRADITION", THE IMAGE OF A STAR AND "SINCE 1703"; THE WORDING "MOUNT GAY RUM" SUPERIMPOSED OVER THE MAP IN LIGHT GRAY LETTERING; THE WORDING "100 PROOF" IN RED TO THE UPPER RIGHT OF THE MAP AND THE WORDING "ECLIPSE BLACK" IN LIGHT GRAY BELOW THE MAP; BELOW THE BORDER, THE WORDING IN DARK GRAY "PRODUCT OF BARBADOS PRODUCED, BLENDED AND EXPORTED BY MOUNT GAY DISTILLERIES LIMITED BRANDONS ST. MICHAEL BARBADOS WEST INDIES", AND BETWEEN THIS WORDING, A SHIELD DEVICE IN GRAY AND BLACK WITH THE LETTERS "MG" IN BLACK.

FOR RUM (U.S. CLS. 47 AND 49).
FIRST USE 3-0-2011; IN COMMERCE 3-0-2011.
CARYN GLASSER, EXAMINING ATTORNEY

CLASS 33—(Continued).

SN 85-446,477. DIAGEO CHATEAU & ESTATE WINES COMPANY, NAPA, CA. FILED 10-13-2011.

L'HISTOIRE PROFONDE

THE MARK CONSISTS OF STANDARD CHARACTERS WITHOUT CLAIM TO ANY PARTICULAR FONT, STYLE, SIZE, OR COLOR.

THE ENGLISH TRANSLATION OF "L'HISTOIRE PROFONDE" IN THE MARK IS "DEEP HISTORY".

FOR ALCOHOLIC BEVERAGES EXCEPT BEERS (U.S. CLS. 47 AND 49).

JORDAN BAKER, EXAMINING ATTORNEY

CLASS 33—(Continued).

SN 85-446,735. DAOU VINEYARDS, LLC, PASO ROBLES, CA. FILED 10-13-2011.

MAYOTE

THE MARK CONSISTS OF STANDARD CHARACTERS WITHOUT CLAIM TO ANY PARTICULAR FONT, STYLE, SIZE, OR COLOR.

FOR RED WINES; STILL WINES; TABLE WINES; WINE; WINES (U.S. CLS. 47 AND 49).

FIRST USE 2-1-2010; IN COMMERCE 9-1-2011.

GENE MACIOL, EXAMINING ATTORNEY

SN 85-446,606. SAN ANTONIO WINERY, INC., LOS ANGELES, CA. FILED 10-13-2011.

IL GIGOLO

THE MARK CONSISTS OF STANDARD CHARACTERS WITHOUT CLAIM TO ANY PARTICULAR FONT, STYLE, SIZE, OR COLOR.

FOR WINES (U.S. CLS. 47 AND 49).

CHRISTINE MARTIN, EXAMINING ATTORNEY

SN 85-446,788. DAOU VINEYARDS, LLC, PASO ROBLES, CA. FILED 10-13-2011.

SOUL OF A LION

THE MARK CONSISTS OF STANDARD CHARACTERS WITHOUT CLAIM TO ANY PARTICULAR FONT, STYLE, SIZE, OR COLOR.

FOR GRAPE WINE; RED WINE; RED WINES; STILL WINES; TABLE WINES; WINE (U.S. CLS. 47 AND 49).

FIRST USE 2-1-2010; IN COMMERCE 9-1-2011.

GENE MACIOL, EXAMINING ATTORNEY

SN 85-446,712. D'ARTAGNAN TRADEMARKS, LLC, NEWARK, NJ. FILED 10-13-2011.

D'ARTAGNAN

THE MARK CONSISTS OF STANDARD CHARACTERS WITHOUT CLAIM TO ANY PARTICULAR FONT, STYLE, SIZE, OR COLOR.

OWNER OF U.S. REG. NOS. 2,106,319, 3,108,584 AND 3,261,726.

FOR WINES (U.S. CLS. 47 AND 49).

KATHRYN COWARD, EXAMINING ATTORNEY

SN 85-446,902. MASTER BRANDS, LLC, WASHINGTON, CT. FILED 10-13-2011.

CAPE CIRCLE

THE MARK CONSISTS OF STANDARD CHARACTERS WITHOUT CLAIM TO ANY PARTICULAR FONT, STYLE, SIZE, OR COLOR.

FOR WINES (U.S. CLS. 47 AND 49).

FIRST USE 9-0-2011; IN COMMERCE 9-0-2011.

MARK SPARACINO, EXAMINING ATTORNEY

CLASS 33—(Continued).

SN 85-446,911. MASTER BRANDS, LLC, WASHINGTON, CT.
FILED 10-13-2011.

ROTATION

THE MARK CONSISTS OF STANDARD CHARACTERS
WITHOUT CLAIM TO ANY PARTICULAR FONT, STYLE,
SIZE, OR COLOR.
FOR WINES (U.S. CLS. 47 AND 49).
MARK SPARACINO, EXAMINING ATTORNEY

CLASS 33—(Continued).

SN 85-447,643. THE WINE GROUP LLC, TRACY, CA. FILED
10-14-2011.

FISSION

THE MARK CONSISTS OF STANDARD CHARACTERS
WITHOUT CLAIM TO ANY PARTICULAR FONT, STYLE,
SIZE, OR COLOR.
FOR WINE (U.S. CLS. 47 AND 49).
CAROLINE WOOD, EXAMINING ATTORNEY

SN 85-447,078. AEROVIN LLC, SANTA ROSA, CA. FILED 10-
13-2011.

GRYPHUS

THE MARK CONSISTS OF STANDARD CHARACTERS
WITHOUT CLAIM TO ANY PARTICULAR FONT, STYLE,
SIZE, OR COLOR.
FOR WINE (U.S. CLS. 47 AND 49).
FIRST USE 8-10-2009; IN COMMERCE 8-10-2009.
TINA MAI, EXAMINING ATTORNEY

SN 85-447,677. JNJ ENTERPRISES, LLC, NORTH HAVEN,
CT. FILED 10-14-2011.

CROP

THE MARK CONSISTS OF STANDARD CHARACTERS
WITHOUT CLAIM TO ANY PARTICULAR FONT, STYLE,
SIZE, OR COLOR.
OWNER OF U.S. REG. NOS. 3,469,232, 3,497,325 AND
3,888,125.
FOR ALCOHOLIC BEVERAGES EXCEPT BEERS (U.S.
CLS. 47 AND 49).
JENNY PARK, EXAMINING ATTORNEY

SN 85-447,491. TERRAVANT WINE COMPANY, LLC, DBA
RED HAWK RANCH WINES, SANTA BARBARA, CA.
FILED 10-14-2011.

RED HAWK RANCH

THE MARK CONSISTS OF STANDARD CHARACTERS
WITHOUT CLAIM TO ANY PARTICULAR FONT, STYLE,
SIZE, OR COLOR.
NO CLAIM IS MADE TO THE EXCLUSIVE RIGHT TO
USE "RANCH", APART FROM THE MARK AS SHOWN.
FOR WINE; WINES (U.S. CLS. 47 AND 49).
KATHERINE STOIDES, EXAMINING ATTORNEY

SN 85-447,753. MEZCAL CALAVERA, S.A. DE C.V., LERMA,
MEXICO, FILED 10-14-2011.



THE MARK CONSISTS OF THE WORD "MONTELOBOS"
SURROUNDED BY A RECTANGLE AND THE COLORS
BLACK REPRESENTS BACKGROUND AND THE WHITE
OUTLINING AND ARE NOT PART OF THE MARK.
THE ENGLISH TRANSLATION OF "MONTE LOBOS" IN
THE MARK IS "MOUNTAIN LIONS".
FOR MEZCAL (U.S. CLS. 47 AND 49).
LESLEY LAMOTHE, EXAMINING ATTORNEY

CLASS 33—(Continued).

SN 85-448,175. H.D.D. LLC, DBA TRUETT HURST WINERY,
HEALDSBURG, CA. FILED 10-14-2011.

MAD DUCK

THE MARK CONSISTS OF STANDARD CHARACTERS
WITHOUT CLAIM TO ANY PARTICULAR FONT, STYLE,
SIZE, OR COLOR.
FOR ALCOHOLIC BEVERAGES EXCEPT BEERS (U.S.
CLS. 47 AND 49).
BERYL GARDNER, EXAMINING ATTORNEY

SN 85-448,198. RAMSEY WINE CELLARS, INC., NAPA, CA.
FILED 10-14-2011.

GrapeHeart

THE MARK CONSISTS OF STANDARD CHARACTERS
WITHOUT CLAIM TO ANY PARTICULAR FONT, STYLE,
SIZE, OR COLOR.
FOR WINE (U.S. CLS. 47 AND 49).
ELIZABETH HUGHITT, EXAMINING ATTORNEY

SN 85-448,345. RODRIGUEZ MORENO, LEONARDO, ATI-
ZAPAN DE ZARAGOZA, MEXICO, FILED 10-15-2011.

LOS ARANGO

THE MARK CONSISTS OF STANDARD CHARACTERS
WITHOUT CLAIM TO ANY PARTICULAR FONT, STYLE,
SIZE, OR COLOR.
OWNER OF MEXICO REG. NO. 993947, DATED 7-23-2007,
EXPIRES 4-13-2017.
THE NAME(S), PORTRAIT(S), AND/OR SIGNATURE(S)
SHOWN IN THE MARK DOES NOT IDENTIFY A PARTI-
CULAR LIVING INDIVIDUAL.
THE ENGLISH TRANSLATION OF "LOS" IN THE MARK
IS THE PLURAL FORM OF "THE".
SEC. 2(F).
FOR TEQUILA (U.S. CLS. 47 AND 49).
FIRST USE 6-1-1996; IN COMMERCE 7-1-2002.
JAY BESCH, EXAMINING ATTORNEY

CLASS 33—(Continued).

SN 85-448,353. THE WINE GROUP LLC, TRACY, CA. FILED
10-15-2011.

SWEET MEMORIES

THE MARK CONSISTS OF STANDARD CHARACTERS
WITHOUT CLAIM TO ANY PARTICULAR FONT, STYLE,
SIZE, OR COLOR.
FOR WINE (U.S. CLS. 47 AND 49).
CAROLINE WOOD, EXAMINING ATTORNEY

SN 85-448,403. WITHERSPOON, QUENTIN D., FLOWER
MOUND, TX. FILED 10-16-2011.

Cross Timbers Whiskey

THE MARK CONSISTS OF STANDARD CHARACTERS
WITHOUT CLAIM TO ANY PARTICULAR FONT, STYLE,
SIZE, OR COLOR.
NO CLAIM IS MADE TO THE EXCLUSIVE RIGHT TO
USE "WHISKEY", APART FROM THE MARK AS SHOWN.
FOR WHISKEY (U.S. CLS. 47 AND 49).
RICHARD WHITE, EXAMINING ATTORNEY

SN 85-448,669. BORJON, ISCANDER, PLYMOUTH, CA.
FILED 10-17-2011.

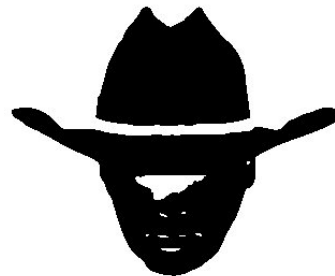

FOR WINE (U.S. CLS. 47 AND 49).
FIRST USE 5-16-2009; IN COMMERCE 5-16-2009.
DAVID TOOLEY, EXAMINING ATTORNEY

CLASS 33—(Continued).

SN 85-448,772. COLUMBIA CONSULTANTS, LLC, NEW YORK, NY. AND DANUCHT ENTERTAINMENT LLC, NEW YORK, NY. FILED 10-17-2011.

10AK

THE MARK CONSISTS OF STANDARD CHARACTERS WITHOUT CLAIM TO ANY PARTICULAR FONT, STYLE, SIZE, OR COLOR.
FOR WINES AND SPIRITS (U.S. CLS. 47 AND 49).
MATTHEW KLINE, EXAMINING ATTORNEY

CLASS 33—(Continued).

SN 85-449,288. LIKE I SAID, LLC, SPOKANE, WA. FILED 10-17-2011.

SOMETHING GOOD POW STRAIGHT TO THE KISSER

THE MARK CONSISTS OF STANDARD CHARACTERS WITHOUT CLAIM TO ANY PARTICULAR FONT, STYLE, SIZE, OR COLOR.
FOR ALCOHOLIC BEVERAGES, NAMELY, DISTILLED SPIRITS (U.S. CLS. 47 AND 49).
ESTHER A. BORSUK, EXAMINING ATTORNEY

SN 85-448,818. SAZERAC COMPANY, INC., METAIRIE, LA. FILED 10-17-2011.

STAND STRONG

THE MARK CONSISTS OF STANDARD CHARACTERS WITHOUT CLAIM TO ANY PARTICULAR FONT, STYLE, SIZE, OR COLOR.
FOR ALCOHOLIC BEVERAGES, NAMELY, DISTILLED SPIRITS (U.S. CLS. 47 AND 49).
FIRST USE 11-7-2011; IN COMMERCE 11-7-2011.
KIMBERLY PERRY, EXAMINING ATTORNEY

SN 85-449,317. INCH, JOSEPH, MONTE SERENO, CA. FILED 10-17-2011.

Champade

THE MARK CONSISTS OF STANDARD CHARACTERS WITHOUT CLAIM TO ANY PARTICULAR FONT, STYLE, SIZE, OR COLOR.
FOR CHAMPAGNE; SPARKLING WINES (U.S. CLS. 47 AND 49).
MATTHEW PAPPAS, EXAMINING ATTORNEY

SN 85-448,913. COLUMBIA CONSULTANTS, LLC, NEW YORK, NY. AND DANUCHT ENTERTAINMENT LLC, NEW YORK, NY. FILED 10-17-2011.

ONE OF A KIND

THE MARK CONSISTS OF STANDARD CHARACTERS WITHOUT CLAIM TO ANY PARTICULAR FONT, STYLE, SIZE, OR COLOR.
FOR WINES AND SPIRITS (U.S. CLS. 47 AND 49).
MATTHEW KLINE, EXAMINING ATTORNEY

SN 85-449,353. MODERN SPIRITS LLC, CA, CA. FILED 10-17-2011.

SLOW HAND

THE MARK CONSISTS OF STANDARD CHARACTERS WITHOUT CLAIM TO ANY PARTICULAR FONT, STYLE, SIZE, OR COLOR.
FOR ALCOHOLIC BEVERAGES EXCEPT BEERS (U.S. CLS. 47 AND 49).
MATTHEW PAPPAS, EXAMINING ATTORNEY

CLASS 33—(Continued).

SN 85-449,460. DRINKS AMERICAS, INC., DBA DRINKS AMERICAS, WILTON, CT. FILED 10-18-2011.

BONGAVE

THE MARK CONSISTS OF STANDARD CHARACTERS WITHOUT CLAIM TO ANY PARTICULAR FONT, STYLE, SIZE, OR COLOR.
FOR SPIRITS (U.S. CLS. 47 AND 49).
KATHERINE STOIDES, EXAMINING ATTORNEY

CLASS 33—(Continued).

SN 85-450,328. DISTILLERS CORPORATION LIMITED, STELLENBOSCH, SOUTH AFRICA, FILED 10-18-2011.



THE MARK CONSISTS OF A PORTRAIT OF A MAN ABOVE "OUDE MEESTER" IN STYLIZED LETTERS. THE ENGLISH TRANSLATION OF "OUDE MEESTER" IN THE MARK IS "OLD MASTER".
FOR BRANDY (U.S. CLS. 47 AND 49).
B. PARADEWELAI, EXAMINING ATTORNEY

SN 85-449,832. MCNEIL WINES, INC., NAPA, CA. FILED 10-18-2011.

BRAINCHILD

THE MARK CONSISTS OF STANDARD CHARACTERS WITHOUT CLAIM TO ANY PARTICULAR FONT, STYLE, SIZE, OR COLOR.
FOR WINES (U.S. CLS. 47 AND 49).
JAY FLOWERS, EXAMINING ATTORNEY

SN 85-450,347. DISTILLERS CORPORATION LIMITED, STELLENBOSCH, SOUTH AFRICA, FILED 10-18-2011.

OUDE MEESTER

THE MARK CONSISTS OF STANDARD CHARACTERS WITHOUT CLAIM TO ANY PARTICULAR FONT, STYLE, SIZE, OR COLOR.
OWNER OF SOUTH AFRICA REG. NO. 76/3550, DATED 7-13-1976, EXPIRES 7-13-2016.
THE ENGLISH TRANSLATION OF "OUDE MEESTER" IN THE MARK IS "OLD MASTER".
FOR BRANDY (U.S. CLS. 47 AND 49).
B. PARADEWELAI, EXAMINING ATTORNEY

SN 85-449,862. MCNEIL WINES, INC., NAPA, CA. FILED 10-18-2011.

TOUGH LOVE

THE MARK CONSISTS OF STANDARD CHARACTERS WITHOUT CLAIM TO ANY PARTICULAR FONT, STYLE, SIZE, OR COLOR.
FOR WINES (U.S. CLS. 47 AND 49).
JAY FLOWERS, EXAMINING ATTORNEY

SN 85-450,388. INDEPENDENT LIQUOR (NZ) LIMITED, PAPAURA, AUCKLAND, NEW ZEALAND, FILED 10-18-2011.

Naughty Cow

THE MARK CONSISTS OF STANDARD CHARACTERS WITHOUT CLAIM TO ANY PARTICULAR FONT, STYLE, SIZE, OR COLOR.
FOR POTABLE SPIRITS; PREPARED ALCOHOLIC COCKTAIL (U.S. CLS. 47 AND 49).
ELI HELLMAN, EXAMINING ATTORNEY

CLASS 33—(Continued).

SN 85-450,641. VINE PRO IMPORTS, LLC., HIALEAH, FL. FILED 10-19-2011.



NO CLAIM IS MADE TO THE EXCLUSIVE RIGHT TO USE "UVA", APART FROM THE MARK AS SHOWN.

THE MARK CONSISTS OF THE WORD "UVA" IN STYLIZED FORM WITHIN A RECTANGLE A DEPICTION OF GRAPES AND LEAF.

THE ENGLISH TRANSLATION OF "UVA" IN THE MARK IS "GRAPE".

FOR WINES BASED IN SIGNIFICANT PART OF GRAPES (U.S. CLS. 47 AND 49).

SEAN CROWLEY, EXAMINING ATTORNEY

SN 85-451,598. STAY @ HOME SOMMELIER LLC, BROOKLYN, NY. FILED 10-19-2011.

A Drop In The Bucket

THE MARK CONSISTS OF STANDARD CHARACTERS WITHOUT CLAIM TO ANY PARTICULAR FONT, STYLE, SIZE, OR COLOR.

FOR WINE (U.S. CLS. 47 AND 49).

SANJEEV VOHRA, EXAMINING ATTORNEY

SN 85-455,874. THE WINE GROUP LLC, TRACY, CA. FILED 10-25-2011.

SWEET & RAD

THE MARK CONSISTS OF STANDARD CHARACTERS WITHOUT CLAIM TO ANY PARTICULAR FONT, STYLE, SIZE, OR COLOR.

FOR WINE (U.S. CLS. 47 AND 49).

CAROLINE WOOD, EXAMINING ATTORNEY

CLASS 33—(Continued).

SN 85-455,876. THE WINE GROUP LLC, TRACY, CA. FILED 10-25-2011.

WALKABOUT RED

THE MARK CONSISTS OF STANDARD CHARACTERS WITHOUT CLAIM TO ANY PARTICULAR FONT, STYLE, SIZE, OR COLOR.

NO CLAIM IS MADE TO THE EXCLUSIVE RIGHT TO USE "RED", APART FROM THE MARK AS SHOWN.

FOR WINE (U.S. CLS. 47 AND 49).

CAROLINE WOOD, EXAMINING ATTORNEY

SN 85-455,877. JPK GROUP, LLC, WHITE PLAINS, NY. FILED 10-25-2011.



NO CLAIM IS MADE TO THE EXCLUSIVE RIGHT TO USE "MOSCATO", APART FROM THE MARK AS SHOWN.

THE MARK CONSISTS OF THE WORDS "MISS" AND "MOSCATO" IN STYLIZED FORM BOTH SHARING AN INITIAL UPPERCASE LETTER "M" WITH THE REMAINING LETTERS IN EACH WORD IN LOWER CASE LETTERS, WITH THE WORD "MISS" APPEARING ABOVE THE WORD "MOSCATO". AN IMAGE OF PARTIALLY FILLED WINE GLASS APPEARS IN THE BACKGROUND BEHIND THE LETTER "A" IN THE WORD "MOSCATO" AND TO THE RIGHT OF THE WORD "MISS".

FOR WINE (U.S. CLS. 47 AND 49).

ESTHER A. BORSUK, EXAMINING ATTORNEY

SN 85-456,507. THE WINE GROUP LLC, TRACY, CA. FILED 10-26-2011.

DONA TERESA

THE MARK CONSISTS OF STANDARD CHARACTERS WITHOUT CLAIM TO ANY PARTICULAR FONT, STYLE, SIZE, OR COLOR.

THE NAME "DONA TERESA" DOES NOT IDENTIFY A LIVING INDIVIDUAL.

FOR WINE (U.S. CLS. 47 AND 49).

CAROLINE WOOD, EXAMINING ATTORNEY

CLASS 33—(Continued).

SN 85-465,438. THE WINE GROUP LLC, TRACY, CA. FILED 11-5-2011.

BITTERSWEET

THE MARK CONSISTS OF STANDARD CHARACTERS WITHOUT CLAIM TO ANY PARTICULAR FONT, STYLE, SIZE, OR COLOR.
FOR SPIRITS; WINE (U.S. CLS. 47 AND 49).
CAROLINE WOOD, EXAMINING ATTORNEY

SN 85-467,949. BODEGA DOMINGO MOLINA, 4427 CAYAYATE SALTA, ARGENTINA, FILED 11-9-2011.

RUPESTRE

THE MARK CONSISTS OF STANDARD CHARACTERS WITHOUT CLAIM TO ANY PARTICULAR FONT, STYLE, SIZE, OR COLOR.
THE ENGLISH TRANSLATION OF "RUPESTRE" IN THE MARK IS "ROCK PAINTINGS".
FOR WINE (U.S. CLS. 47 AND 49).
ZACHARY BELLO, EXAMINING ATTORNEY

SN 85-475,254. THE WINE GROUP LLC, TRACY, CA. FILED 11-17-2011.

DRINK IN THE MOMENT

THE MARK CONSISTS OF STANDARD CHARACTERS WITHOUT CLAIM TO ANY PARTICULAR FONT, STYLE, SIZE, OR COLOR.
FOR LIQUEURS; PREPARED ALCOHOLIC COCKTAIL; PREPARED WINE COCKTAILS; SPIRITS; WINE; WINE-BASED DRINKS (U.S. CLS. 47 AND 49).
CAROLINE WOOD, EXAMINING ATTORNEY

CLASS 33—(Continued).

SN 85-476,354. THE WINE GROUP LLC, TRACY, CA. FILED 11-18-2011.

RIPPIN' RED

THE MARK CONSISTS OF STANDARD CHARACTERS WITHOUT CLAIM TO ANY PARTICULAR FONT, STYLE, SIZE, OR COLOR.
NO CLAIM IS MADE TO THE EXCLUSIVE RIGHT TO USE "RED", APART FROM THE MARK AS SHOWN.
FOR LIQUEURS; PREPARED ALCOHOLIC COCKTAIL; PREPARED WINE COCKTAILS; SPIRITS; WINE-BASED DRINKS; WINES (U.S. CLS. 47 AND 49).
CAROLINE WOOD, EXAMINING ATTORNEY

SN 85-476,355. THE WINE GROUP LLC, TRACY, CA. FILED 11-18-2011.

VINLOCK

THE MARK CONSISTS OF STANDARD CHARACTERS WITHOUT CLAIM TO ANY PARTICULAR FONT, STYLE, SIZE, OR COLOR.
FOR LIQUEURS; PREPARED ALCOHOLIC COCKTAIL; PREPARED WINE COCKTAILS; SPIRITS; WINE-BASED DRINKS; WINES (U.S. CLS. 47 AND 49).
CAROLINE WOOD, EXAMINING ATTORNEY

SN 85-480,717. YEALANDS ESTATE WINES LIMITED, MARLBOROUGH, NEW ZEALAND, FILED 11-24-2011.

GREENSHELL

THE MARK CONSISTS OF STANDARD CHARACTERS WITHOUT CLAIM TO ANY PARTICULAR FONT, STYLE, SIZE, OR COLOR.
FOR WINE (U.S. CLS. 47 AND 49).
HANNO RITTNER, EXAMINING ATTORNEY

CLASS 33—(Continued).

SN 85-481,666. VINOCOPIA, INC., RICHFIELD, MN. FILED 11-28-2011.

CAPRICCIO

THE MARK CONSISTS OF STANDARD CHARACTERS WITHOUT CLAIM TO ANY PARTICULAR FONT, STYLE, SIZE, OR COLOR.

THE ENGLISH TRANSLATION OF "CAPRICCIO" IN THE MARK IS "CAPRICE".

FOR WINE (U.S. CLS. 47 AND 49).
DAWN HAN, EXAMINING ATTORNEY

SN 85-491,325. SPIRITS INTERNATIONAL B.V., LUXEMBOURG, LUXEMBOURG, FILED 12-9-2011.

STOLI STICKI

THE MARK CONSISTS OF STANDARD CHARACTERS WITHOUT CLAIM TO ANY PARTICULAR FONT, STYLE, SIZE, OR COLOR.

OWNER OF U.S. REG. NOS. 865,462, 1,291,454 AND OTHERS.

FOR ALCOHOLIC BEVERAGES, NAMELY, VODKA, FLAVORED VODKA, VODKA-BASED DRINK, VODKA-BASED ALCOHOLIC COCKTAIL (U.S. CLS. 47 AND 49).
ROBERT STRUCK, EXAMINING ATTORNEY

SN 85-492,869. MACHAT, MICHAEL, BEVERLY HILLS, CA. FILED 12-12-2011.

BATS BLOOD

THE MARK CONSISTS OF STANDARD CHARACTERS WITHOUT CLAIM TO ANY PARTICULAR FONT, STYLE, SIZE, OR COLOR.

FOR DISTILLED SPIRITS; LIQUEURS; WINE (U.S. CLS. 47 AND 49).

SIMON TENG, EXAMINING ATTORNEY

CLASS 33—(Continued).

SN 85-499,566. SAN ANTONIO WINERY, INC., LOS ANGELES, CA. FILED 12-20-2011.

SHOWTIME

THE MARK CONSISTS OF STANDARD CHARACTERS WITHOUT CLAIM TO ANY PARTICULAR FONT, STYLE, SIZE, OR COLOR.

FOR WINE (U.S. CLS. 47 AND 49).

CHRISTINE MARTIN, EXAMINING ATTORNEY

SN 85-504,188. SAN ANTONIO WINERY, INC., LOS ANGELES, CA. FILED 12-27-2011.

STELLA BIANCO

THE MARK CONSISTS OF STANDARD CHARACTERS WITHOUT CLAIM TO ANY PARTICULAR FONT, STYLE, SIZE, OR COLOR.

NO CLAIM IS MADE TO THE EXCLUSIVE RIGHT TO USE "BIANCO", APART FROM THE MARK AS SHOWN.

THE ENGLISH TRANSLATION OF "STELLA BIANCO" IN THE MARK IS "STAR WHITE".

FOR WINE (U.S. CLS. 47 AND 49).

CHRISTINE MARTIN, EXAMINING ATTORNEY

SN 85-504,191. SAN ANTONIO WINERY, INC., LOS ANGELES, CA. FILED 12-27-2011.

STELLA ROSSO

THE MARK CONSISTS OF STANDARD CHARACTERS WITHOUT CLAIM TO ANY PARTICULAR FONT, STYLE, SIZE, OR COLOR.

NO CLAIM IS MADE TO THE EXCLUSIVE RIGHT TO USE "ROSSO", APART FROM THE MARK AS SHOWN.

THE ENGLISH TRANSLATION OF "STELLA ROSSO" IN THE MARK IS "STAR RED".

FOR WINE (U.S. CLS. 47 AND 49).

CHRISTINE MARTIN, EXAMINING ATTORNEY

CLASS 34—SMOKERS' ARTICLES

CLASS 34—(Continued).

SN 85-092,543. OETTINGER IMEX AG, BASEL, SWITZERLAND, FILED 7-26-2010.

SN 85-307,262. PHILIP MORRIS USA INC., RICHMOND, VA. FILED 4-28-2011.

PUROS SERIES 5

MARLBORO BLEND 32

THE MARK CONSISTS OF STANDARD CHARACTERS WITHOUT CLAIM TO ANY PARTICULAR FONT, STYLE, SIZE, OR COLOR.

NO CLAIM IS MADE TO THE EXCLUSIVE RIGHT TO USE "PUROS" AND "SERIES", APART FROM THE MARK AS SHOWN.

FOR TOBACCO PRODUCTS, NAMELY, CIGARS, CIGARILLOS, SMOKING TOBACCO; SMOKERS' ARTICLES, NAMELY, CIGAR CUTTERS, NON-ELECTRIC CIGAR AND CIGARETTE LIGHTERS, CIGAR HUMIDIFIERS, CIGAR CASES WITH HUMIDOR; TOBACCO BOXES, CIGAR CASES, ASHTRAYS, LIGHTERS, MATCHES (U.S. CLS. 2, 8, 9 AND 17).

WILLIAM ROSSMAN, EXAMINING ATTORNEY

THE MARK CONSISTS OF STANDARD CHARACTERS WITHOUT CLAIM TO ANY PARTICULAR FONT, STYLE, SIZE, OR COLOR.

OWNER OF U.S. REG. NOS. 68,502, 4,002,642 AND OTHERS.

NO CLAIM IS MADE TO THE EXCLUSIVE RIGHT TO USE "BLEND", APART FROM THE MARK AS SHOWN.

FOR TOBACCO PRODUCTS, NAMELY, CIGARETTES (U.S. CLS. 2, 8, 9 AND 17).

FIRST USE 3-9-2011; IN COMMERCE 3-9-2011.
EDWARD NELSON, EXAMINING ATTORNEY

SN 85-272,579. SWEDISH MATCH NORTH EUROPE AB, STOCKHOLM, SWEDEN, FILED 3-21-2011.

SN 85-309,463. LEIKAS, ANDREW, PORTLAND, OR. FILED 5-2-2011.



Mellow Mood

OWNER OF SWEDEN REG. NO. 418376, DATED 5-13-2011, EXPIRES 5-13-2021.

THE MARK CONSISTS OF THE WORD "KALIBER" WITH THREE HORIZONTAL LINES CENTERED ABOVE THE LETTERS "L", "I" AND "B" OF THE WORD "KALIBER".

THE ENGLISH TRANSLATION OF "KALIBER" IN THE MARK IS "CALIBER".

FOR TOBACCO; MATCHES; TOBACCO SUBSTITUTES NOT FOR MEDICAL PURPOSES; SNUFF AND TOBACCO ALTERNATIVES IN THE FORM OF PRODUCTS BASED ON VEGETABLE FIBERS, FOR ORAL USE, NOT FOR CONSUMPTION; SNUFF; TOBACCO FREE SNUFF; HERBAL SNUFF (U.S. CLS. 2, 8, 9 AND 17).

DORITT L. CARROLL, EXAMINING ATTORNEY

THE MARK CONSISTS OF STANDARD CHARACTERS WITHOUT CLAIM TO ANY PARTICULAR FONT, STYLE, SIZE, OR COLOR.

FOR SMOKING PIPES; SMOKING TOBACCO; TOBACCO; TOBACCO JARS; TOBACCO PIPES; TOBACCO TINS; TOBACCO WATER PIPES (U.S. CLS. 2, 8, 9 AND 17).

FIRST USE 3-7-2001; IN COMMERCE 3-7-2001.
SANJEEV VOHRA, EXAMINING ATTORNEY

CLASS 34—(Continued).

SN 85-335,184. SWEDISH MATCH NORTH EUROPE AB, STOCKHOLM, SWEDEN, FILED 6-1-2011.



PRIORITY CLAIMED UNDER SEC. 44(D) ON SWEDEN APPLICATION NO. 2011/00826, FILED 1-28-2011, REG. NO. 418415, DATED 5-20-2011, EXPIRES 5-20-2021.

THE MARK CONSISTS OF A SQUARE WITH ROUNDED CORNERS. THE SQUARE IS DIVIDED INTO TWO PORTIONS BY A HORIZONTAL LINE APPROXIMATELY THREE QUARTERS OF THE WAY DOWN. THE TOP PORTION CONTAINS A PLUS SIGN AND A RIGHT-ANGLE TRIANGLE FACING TO THE LEFT. THE BOTTOM PORTION CONTAINS THE WORD "STRENGTH".

FOR TOBACCO; MATCHES; TOBACCO SUBSTITUTES NOT FOR MEDICAL PURPOSES; SNUFF AND TOBACCO ALTERNATIVES IN THE FORM OF PRODUCTS BASED ON VEGETABLE FIBERS, FOR ORAL USE, NOT FOR CONSUMPTION; SNUFF; TOBACCO FREE SNUFF; HERBAL SNUFF (U.S. CLS. 2, 8, 9 AND 17).
HENRY S. ZAK, EXAMINING ATTORNEY

SN 85-335,209. SWEDISH MATCH NORTH EUROPE AB, STOCKHOLM, SWEDEN, FILED 6-1-2011.

06

THE MARK CONSISTS OF STANDARD CHARACTERS WITHOUT CLAIM TO ANY PARTICULAR FONT, STYLE, SIZE, OR COLOR.

PRIORITY CLAIMED UNDER SEC. 44(D) ON SWEDEN APPLICATION NO. 2011/00825, FILED 1-28-2011, REG. NO. 500185, DATED 8-12-2011, EXPIRES 8-12-2021.

FOR TOBACCO; MATCHES; TOBACCO SUBSTITUTES NOT FOR MEDICAL PURPOSES; SNUFF AND TOBACCO ALTERNATIVES IN THE FORM OF PRODUCTS BASED ON VEGETABLE FIBERS, FOR ORAL USE, NOT FOR CONSUMPTION; SNUFF; TOBACCO FREE SNUFF; HERBAL SNUFF (U.S. CLS. 2, 8, 9 AND 17).
HENRY S. ZAK, EXAMINING ATTORNEY

CLASS 34—(Continued).

SN 85-362,517. THE SAFE CIG, LLC, LOS ANGELES, CA, FILED 7-3-2011.

HOLLYWOOD CIGS

THE MARK CONSISTS OF STANDARD CHARACTERS WITHOUT CLAIM TO ANY PARTICULAR FONT, STYLE, SIZE, OR COLOR.

NO CLAIM IS MADE TO THE EXCLUSIVE RIGHT TO USE "CIGS", APART FROM THE MARK AS SHOWN, FOR ELECTRONIC CIGARETTES (U.S. CLS. 2, 8, 9 AND 17).

ANNE E. GUSTASON, EXAMINING ATTORNEY

SN 85-366,449. GN TOBACCO SWEDEN AB, JARFALLA, SWEDEN, FILED 7-8-2011.

OLDE VING

THE MARK CONSISTS OF STANDARD CHARACTERS WITHOUT CLAIM TO ANY PARTICULAR FONT, STYLE, SIZE, OR COLOR.

OWNER OF SWEDEN REG. NO. 500762, DATED 9-23-2011, EXPIRES 9-23-2021.

FOR SNUFF; SNUFF BOXES (U.S. CLS. 2, 8, 9 AND 17).
DOMINIC FATHY, EXAMINING ATTORNEY

SN 85-396,846. COMMONWEALTH BRANDS, INC., BOWLING GREEN, KY. FILED 8-12-2011.



OWNER OF U.S. REG. NO. 3,743,331.
THE MARK CONSISTS OF THE FANCIFUL DEPICTION OF A BULL STANDING BEHIND A FENCE OR HITTING POST.

FOR CIGARETTES (U.S. CLS. 2, 8, 9 AND 17).
BARBARA BROWN, EXAMINING ATTORNEY

CLASS 34—(Continued).

SN 85-422,976. HIGH GRADE HERBAL INC., DBA NATURAL LEAF INC., DANIA, FL. FILED 9-14-2011.

HGH Natural Leaf All Natural Tobacco

THE MARK CONSISTS OF STANDARD CHARACTERS WITHOUT CLAIM TO ANY PARTICULAR FONT, STYLE, SIZE, OR COLOR.

NO CLAIM IS MADE TO THE EXCLUSIVE RIGHT TO USE "NATURAL LEAF ALL NATURAL TOBACCO", APART FROM THE MARK AS SHOWN.

FOR HAND-ROLLING TOBACCO; ROLL YOUR OWN TOBACCO; SMOKING TOBACCO; TOBACCO; TOBACCO, CIGARS AND CIGARETTES (U.S. CLS. 2, 8, 9 AND 17).

FIRST USE 1-11-2009; IN COMMERCE 1-31-2009.
NICHOLAS COLEMAN, EXAMINING ATTORNEY

SN 85-425,715. TABACALERA EL ARTISTA S.R.L., FORMERLY TABACALERA EL ARTISTA S.A., TAMBORIL, STGO, DOMINICAN REP, FILED 9-19-2011.



THE MARK CONSISTS OF A SHIELD WITH STRIPES AND A LION AND WITH WINGS ON THE SIDES AND STARS ON THE TOP AND THE WORD "HEREDEROS" AT THE BOTTOM.

THE ENGLISH TRANSLATION OF THE WORD "HEREDEROS" IN THE MARK IS "HEIRS".

FOR CIGARS (U.S. CLS. 2, 8, 9 AND 17).
MARGARET POWER, EXAMINING ATTORNEY

SN 85-440,404. K. HANSOTIA & CO., INC., MIAMI, FL. FILED 10-6-2011.

VICTORIA CROSS

THE MARK CONSISTS OF STANDARD CHARACTERS WITHOUT CLAIM TO ANY PARTICULAR FONT, STYLE, SIZE, OR COLOR.

FOR CIGARS (U.S. CLS. 2, 8, 9 AND 17).
NAKIA HENRY, EXAMINING ATTORNEY

CLASS 34—(Continued).

SN 85-444,027. YOUSIF, JOHNATHAN JOSEPH, DETROIT, MI. FILED 10-11-2011.



THE MARK CONSISTS OF A PAIR OF WINGS WITH A BADGE IN THE MIDDLE OF THE WINGS HAVING THE LETTERS "LU-C" IN STYLIZED FORM.

FOR CIGARETTES (U.S. CLS. 2, 8, 9 AND 17).
EDWARD NELSON, EXAMINING ATTORNEY

SN 85-446,511. SMOKE INN, LLC, WEST PALM BEACH, FL. FILED 10-13-2011.

APOCALYPSE

THE MARK CONSISTS OF STANDARD CHARACTERS WITHOUT CLAIM TO ANY PARTICULAR FONT, STYLE, SIZE, OR COLOR.

FOR CIGARS (U.S. CLS. 2, 8, 9 AND 17).
TARAH HARDY, EXAMINING ATTORNEY

SN 85-447,335. VISION TECH GROUP LLC, DBA CLOUD-CIGS.COM, VALPARAISO, IN. FILED 10-14-2011.

CloudCigs

THE MARK CONSISTS OF STANDARD CHARACTERS WITHOUT CLAIM TO ANY PARTICULAR FONT, STYLE, SIZE, OR COLOR.

FOR ELECTRIC CIGARETTES; ELECTRONIC CIGARETTES; ELECTRONIC CIGARETTES FOR USE AS AN ALTERNATIVE TO TRADITIONAL CIGARETTES; SMOKELESS CIGARETTE VAPORIZER PIPE; TOBACCO SUBSTITUTE; TOBACCO SUBSTITUTES NOT FOR MEDICAL PURPOSES (U.S. CLS. 2, 8, 9 AND 17).

FIRST USE 4-20-2010; IN COMMERCE 9-11-2010.
BRIDGETT SMITH, EXAMINING ATTORNEY

CLASS 34—(Continued).

SN 85-449,533. DE SONIA, FRANK, FOREST PARK, IL. FILED 10-18-2011.

Butt Huggers

THE MARK CONSISTS OF STANDARD CHARACTERS WITHOUT CLAIM TO ANY PARTICULAR FONT, STYLE, SIZE, OR COLOR.

FOR CIGARETTE PACK HOLDERS NOT OF PRECIOUS METAL (U.S. CLS. 2, 8, 9 AND 17).
CURTIS FRENCH, EXAMINING ATTORNEY

SN 85-475,007. NATIONAL TOBACCO COMPANY, L.P., LOUISVILLE, KY. FILED 11-17-2011.

KB-90

THE MARK CONSISTS OF STANDARD CHARACTERS WITHOUT CLAIM TO ANY PARTICULAR FONT, STYLE, SIZE, OR COLOR.

FOR CIGARS; SMOKING TOBACCO; TOBACCO (U.S. CLS. 2, 8, 9 AND 17).
SETH A. RAPPAPORT, EXAMINING ATTORNEY

SN 85-475,160. NATIONAL TOBACCO COMPANY, L.P., LOUISVILLE, KY. FILED 11-17-2011.

BLACK STINGER

THE MARK CONSISTS OF STANDARD CHARACTERS WITHOUT CLAIM TO ANY PARTICULAR FONT, STYLE, SIZE, OR COLOR.

FOR CIGARS; SMOKING TOBACCO; TOBACCO (U.S. CLS. 2, 8, 9 AND 17).
SETH A. RAPPAPORT, EXAMINING ATTORNEY

CLASS 34—(Continued).

SN 85-479,081. XIKAR, INC., KANSAS CITY, MO. FILED 11-22-2011.



THE MARK CONSISTS OF A CARICATURE OF A SARDINE SMOKING A CIGAR.

FOR CIGAR CUTTERS (U.S. CLS. 2, 8, 9 AND 17).
FIRST USE 5-1-2003; IN COMMERCE 5-1-2003.
CHRISTOPHER BUONGIORNO, EXAMINING ATTORNEY

SN 85-486,329. NATIONAL TOBACCO COMPANY, L.P., LOUISVILLE, KY. FILED 12-2-2011.



THE MARK CONSISTS OF A DOUBLE CIRCLE DIVIDED DOWN THE MIDDLE BY A CURVED LINE AND HAVING HATCHED LINES ACROSS THE CIRCLES WHICH BECOME BLURRED AND DARKER ON THE RIGHT SIDE OF THE CIRCLES; THE WORD "RIPTIDE" IS CENTERED IN THE MIDDLE OF THE INNER CIRCLE.

FOR CHEWING TOBACCO; CIGARETTES; CIGARILLOS; CIGARS; HOOKAH TOBACCO; PIPE TOBACCO; ROLL YOUR OWN TOBACCO; SMOKELESS TOBACCO; SMOKING TOBACCO; SNUFF; TOBACCO; TOBACCO POWDER, NAMELY, SNUS (U.S. CLS. 2, 8, 9 AND 17).
SETH A. RAPPAPORT, EXAMINING ATTORNEY

CLASS 35—(Continued).

CLASS 35—(Continued).

SN 77-760,463. FANTASY DIAMOND CORPORATION, CHICAGO, IL. FILED 6-16-2009.

SERVICE MARKS

LIVE CATALOG

CLASS 35—ADVERTISING AND BUSINESS

SN 76-707,470. TEMPESTA MEDIA, CHICAGO, IL. FILED 5-2-2011.

**TEMPESTA
MEDIA**

THE MARK CONSISTS OF STANDARD CHARACTERS WITHOUT CLAIM TO ANY PARTICULAR FONT, STYLE, SIZE, OR COLOR.

NO CLAIM IS MADE TO THE EXCLUSIVE RIGHT TO USE "CATALOG", APART FROM THE MARK AS SHOWN. FOR WHOLESALE DISTRIBUTORSHIPS AND ORDERING SERVICES IN THE FIELD OF JEWELRY (U.S. CLS. 100, 101 AND 102).

FIRST USE 6-15-2009; IN COMMERCE 6-15-2009. STEVEN PEREZ, EXAMINING ATTORNEY

THE MARK CONSISTS OF STANDARD CHARACTERS WITHOUT CLAIM TO ANY PARTICULAR FONT, STYLE, SIZE, OR COLOR.

NO CLAIM IS MADE TO THE EXCLUSIVE RIGHT TO USE "MEDIA", APART FROM THE MARK AS SHOWN.

THE ENGLISH TRANSLATION OF "TEMPESTA" IN THE MARK IS "STORM."

FOR DOMAIN RESEARCH, DEVELOPMENT AND MONETIZATION SERVICES, NAMELY, SERVICES RELATED TO THE ANALYSIS, EVALUATION AND BRAND ESTABLISHMENT OF DOMAIN NAMES; DOMAIN RESEARCH, DEVELOPMENT AND MONETIZATION SERVICES, NAMELY, SERVICES RELATING TO THE OBTAINMENT AND PLACEMENT OF ADVERTISEMENTS ON THE DOMAIN NAMES OF OTHERS (U.S. CLS. 100, 101 AND 102).

FIRST USE 8-1-2008; IN COMMERCE 8-1-2008. RENEE MCCRAY, EXAMINING ATTORNEY

SN 77-966,135. CALACANIS, LLC, SANTA MONICA, CA. FILED 3-23-2010.

LAUNCH

THE MARK CONSISTS OF STANDARD CHARACTERS WITHOUT CLAIM TO ANY PARTICULAR FONT, STYLE, SIZE, OR COLOR.

FOR ORGANIZATION OF BUSINESS CONVENTIONS FOR CONNECTING ENTREPRENEURS AND INVESTORS IN THE FIELD OF INTERNET PRODUCTS AND SERVICES (U.S. CLS. 100, 101 AND 102).

DOMINIC FATHY, EXAMINING ATTORNEY

SN 77-600,287. ICG COMMERCE, INC., KING OF PRUSSIA, PA. FILED 10-24-2008.

ICG COMMERCE

SN 79-098,167. ALGOQUEST, SOCIÉTÉ ANONYME, B-1040 ETTERBEEK, BELGIUM, FILED 4-6-2011.

ALGOQUEST

THE MARK CONSISTS OF STANDARD CHARACTERS WITHOUT CLAIM TO ANY PARTICULAR FONT, STYLE, SIZE, OR COLOR.

OWNER OF U.S. REG. NO. 2,652,339.

NO CLAIM IS MADE TO THE EXCLUSIVE RIGHT TO USE "COMMERCE", APART FROM THE MARK AS SHOWN.

FOR PROCUREMENT OUTSOURCING SERVICES FOR A WIDE VARIETY OF GOODS AND SERVICES OF OTHERS; BUSINESS AND MANAGEMENT CONSULTING IN THE FIELD OF PROCUREMENT (U.S. CLS. 100, 101 AND 102).

FIRST USE 1-1-2001; IN COMMERCE 1-1-2001. MICHAEL KEATING, EXAMINING ATTORNEY

THE MARK CONSISTS OF STANDARD CHARACTERS WITHOUT CLAIM TO ANY PARTICULAR FONT, STYLE, SIZE, OR COLOR.

PRIORITY DATE OF 10-18-2010 IS CLAIMED.

OWNER OF INTERNATIONAL REGISTRATION 1079409 DATED 4-6-2011, EXPIRES 4-6-2021.

FOR COMPILATION AND SYSTEMIZATION OF DATA INTO COMPUTER DATABASES; COMPUTERIZED FILE MANAGEMENT (U.S. CLS. 100, 101 AND 102).

ADA HAN, EXAMINING ATTORNEY

CLASS 35—(Continued).

SN 79-106,553. ULRICH GARTNER, FED REP GERMANY, FILED 10-6-2011.

InfiniteLatitude
COMMUNICATIONS EXPERTISE
WORLDWIDE

OWNER OF INTERNATIONAL REGISTRATION 1100147 DATED 10-6-2011, EXPIRES 10-6-2021.

NO CLAIM IS MADE TO THE EXCLUSIVE RIGHT TO USE "COMMUNICATIONS EXPERTISE WORLDWIDE", APART FROM THE MARK AS SHOWN.

THE COLOR(S) GREEN, BLUE AND GREY IS/ARE CLAIMED AS A FEATURE OF THE MARK.

THE MARK CONSISTS OF THE WORD "INFINITE" IN GREEN, THE WORD "LATITUDE" IN BLUE AND THE WORDS "COMMUNICATIONS EXPERTISE WORLDWIDE" IN GREY.

FOR COMMUNICATIONS CONSULTANCY (U.S. CLS. 100, 101 AND 102).

DOMINIC FATHY, EXAMINING ATTORNEY

SN 85-006,580. EVOFURNITURE, LLC, HAWORTH, NJ, FILED 4-5-2010.

EVOFURNITURE

THE MARK CONSISTS OF STANDARD CHARACTERS WITHOUT CLAIM TO ANY PARTICULAR FONT, STYLE, SIZE, OR COLOR.

FOR ON-LINE RETAIL STORE SERVICES FEATURING FURNITURE (U.S. CLS. 100, 101 AND 102).

FIRST USE 1-1-2002; IN COMMERCE 1-1-2002.

STEVEN R. FINE, EXAMINING ATTORNEY

SN 85-038,057. CAMBRIDGE HOUSE INTERNATIONAL INC., VANCOUVER, BRITISH COLUMBIA, FILED 5-13-2010.

THE
SILVER
SUMMIT

NO CLAIM IS MADE TO THE EXCLUSIVE RIGHT TO USE "SILVER", APART FROM THE MARK AS SHOWN.

THE MARK CONSISTS OF THE WORDING "THE SILVER SUMMIT" IN STYLIZED FORM WITH A STYLIZED DESIGN OF MOUNTAINS.

FOR ARRANGING AND CONDUCTING TRADE SHOW EXHIBITIONS IN THE FIELD OF SILVER MINING (U.S. CLS. 100, 101 AND 102).

FIRST USE 1-31-2008; IN COMMERCE 1-31-2008.

STEVEN PEREZ, EXAMINING ATTORNEY

CLASS 35—(Continued).

SN 85-056,825. FRONTIER COMMUNICATIONS CORPORATION, STAMFORD, CT. FILED 6-7-2010.

THE CONVERSATION COMPANY

THE MARK CONSISTS OF STANDARD CHARACTERS WITHOUT CLAIM TO ANY PARTICULAR FONT, STYLE, SIZE, OR COLOR.

NO CLAIM IS MADE TO THE EXCLUSIVE RIGHT TO USE "COMPANY", APART FROM THE MARK AS SHOWN.

FOR PROVIDING RESIDENTIAL AND COMMERCIAL DIRECTORY INFORMATION VIA TELEPHONE AND GLOBAL COMMUNICATIONS NETWORKS; PROVIDING ONLINE DIRECTORY INFORMATION SERVICES FEATURING HYPERLINKS TO THE WEBSITES OF OTHERS; PROVIDING CONSUMER PRODUCT INFORMATION VIA THE INTERNET; SEARCH ENGINE MARKETING SERVICES, NAMELY, PROMOTING THE GOODS AND SERVICES OF OTHERS BY INCREASING THEIR VISIBILITY IN SEARCH ENGINE RESULTS THROUGH TECHNIQUES SUCH AS KEYWORD ANALYSIS AND PLANNING, PAID INCLUSION, PAID PLACEMENT, AND CONTEXTUAL MARKETING; ADVERTISING THE GOODS AND SERVICES OF OTHERS THROUGH WEB PAGES OPTIMIZED FOR ONLINE SEARCH ENGINES; GEOMARKETING SERVICES FOR OTHERS, NAMELY, USING GEOGRAPHIC INFORMATION ABOUT WEBSITE VISITORS IN THE COURSE OF PLANNING AND IMPLEMENTING TARGETED ADVERTISING CAMPAIGNS FOR OTHERS; ADVERTISING SERVICES, NAMELY, CREATING ADVERTISING MATERIAL FOR OTHERS; DISSEMINATING ADVERTISING MATERIAL FOR OTHERS; PROMOTING THE GOODS AND SERVICES OF OTHERS THROUGH THE DISTRIBUTION OF PRINTED PROMOTIONAL MATTER AND ELECTRONICALLY-TRANSMITTED PROMOTIONAL MATTER; PROMOTING THE GOODS AND SERVICES OF OTHERS BY ANALYZING AND REPORTING ON SEARCH ENGINE, WEB SITE, AND ADVERTISEMENT TRAFFIC AND CLICK-THROUGH RATES; MANAGING ONLINE ADVERTISING CAMPAIGNS FOR OTHERS; PROVIDING ADVERTISING SPACE ON THE INTERNET TO OTHERS; PROVIDING BILLING AND CUSTOMER RELATIONS SERVICES ON BEHALF OF OTHERS; ADMINISTRATION, BILLING, AND RECONCILIATION OF ACCOUNTS ON BEHALF OF OTHERS; RETAIL STORE SERVICES FEATURING TELECOMMUNICATION PRODUCTS, TELECOMMUNICATION SERVICE PLANS, AND TELECOMMUNICATION SERVICE ACTIVATION; COMPUTERIZED ONLINE RETAIL STORE SERVICES FEATURING TELECOMMUNICATION PRODUCTS, TELECOMMUNICATION SERVICE PLANS, AND TELECOMMUNICATION SERVICE ACTIVATION; CUSTOMER LOYALTY SERVICES FOR COMMERCIAL, PROMOTIONAL, AND/OR ADVERTISING PURPOSES; PROVIDING INCENTIVE AWARD PROGRAMS FOR CUSTOMERS THROUGH THE ISSUANCE OF DONATIONS TO QUALIFIED SCHOOLS, LIBRARIES, RELIGIOUS INSTITUTIONS, COMMUNITY-BASED ORGANIZATIONS, NOT-FOR-PROFIT ORGANIZATIONS, BUSINESS ORGANIZATIONS, AND TRADE ASSOCIATIONS, ALL AT THE DIRECTION OF PARTICIPATING CUSTOMERS AND FOR THE PURPOSE OF PROMOTING CUSTOMER RECRUITMENT AND RETENTION (U.S. CLS. 100, 101 AND 102).

CHARLES L. JENKINS, EXAMINING ATTORNEY

CLASS 35—(Continued).

SN 85-118,559. CITY OF VISTA, VISTA, CA. FILED 8-30-2010.



NO CLAIM IS MADE TO THE EXCLUSIVE RIGHT TO USE "CITY OF VISTA" AND "CALIFORNIA", APART FROM THE MARK AS SHOWN.

THE COLOR(S) GREEN, BLUE AND YELLOW IS/ARE CLAIMED AS A FEATURE OF THE MARK.

THE MARK CONSISTS OF "CITY OF VISTA" IN BLUE STYLIZED LETTERS WITH A GREEN MOUNTAIN LANDSCAPE LINE ABOVE THE "CITY OF VISTA" AND A YELLOW STYLIZED SUN ABOVE THE MOUNTAIN LANDSCAPE ON THE RIGHT SIDE. BELOW THE "CITY OF VISTA" IS THE WORD "CALIFORNIA" IN YELLOW LETTERS WITH ONE BLUE HORIZONTAL LINE ABOVE "CALIFORNIA" AND ONE BLUE HORIZONTAL LINE BELOW "CALIFORNIA".

THE ENGLISH TRANSLATION OF "VISTA" IN THE MARK IS "VIEW".

FOR INFORMATION IN THE FIELD OF GOVERNMENT AFFAIRS (U.S. CLS. 100, 101 AND 102).

FIRST USE 6-10-2009; IN COMMERCE 6-10-2009.
HEATHER BIDDULPH, EXAMINING ATTORNEY

SN 85-119,258. SOUTH ARTS, INC., FORMERLY SOUTHERN ARTS FEDERATION, ATLANTA, GA. FILED 8-30-2010.

ARTSREADY

THE MARK CONSISTS OF STANDARD CHARACTERS WITHOUT CLAIM TO ANY PARTICULAR FONT, STYLE, SIZE, OR COLOR.

FOR PROVIDING A WEBSITE FEATURING INFORMATION, DATABASES, DOCUMENTS, AND WEBSITE LINKS RELATED TO BUSINESS CONTINUITY AND BUSINESS MANAGEMENT DURING A CRISIS AND READINESS PLANNING FOR CONTINUING BUSINESS OPERATIONS AFTER A CRISIS (U.S. CLS. 100, 101 AND 102).

FIRST USE 3-2-2010; IN COMMERCE 3-2-2010.
KATHERINE CHANG, EXAMINING ATTORNEY

CLASS 35—(Continued).

SN 85-123,848. GRUPO VL, INC., CAGUAS, PUERTO RICO, FILED 9-7-2010.

FLEX 90

THE MARK CONSISTS OF STANDARD CHARACTERS WITHOUT CLAIM TO ANY PARTICULAR FONT, STYLE, SIZE, OR COLOR.

NO CLAIM IS MADE TO THE EXCLUSIVE RIGHT TO USE "90", APART FROM THE MARK AS SHOWN.

FOR RETAIL PHARMACY SERVICES, NAMELY, PROMOTING A NINETY-DAY SUPPLY OF PHARMACEUTICALS; MAIL ORDER PHARMACY SERVICES (U.S. CLS. 100, 101 AND 102).

FIRST USE 4-25-2007; IN COMMERCE 4-25-2007.
GRETCHEN ULRICH, EXAMINING ATTORNEY

SN 85-130,885. ADSENSA LTD., NEWBURY, BERKSHIRE, UNITED KINGDOM, FILED 9-16-2010.

ADSENSA

THE MARK CONSISTS OF STANDARD CHARACTERS WITHOUT CLAIM TO ANY PARTICULAR FONT, STYLE, SIZE, OR COLOR.

PRIORITY CLAIMED UNDER SEC. 44(D) ON ERPN CMNTY TM OFC APPLICATION NO. 9297029, FILED 8-5-2010, REG. NO. 9297029, DATED 6-10-2011, EXPIRES 8-5-2020.

FOR BUSINESS RECORDS MANAGEMENT IN THE FIELD OF DOCUMENT FINDING, NAMELY, SEARCHING A COLLECTION OF BUSINESS DOCUMENTS TO LOCATE DOCUMENTS WHICH ARE SIMILAR TO OTHER DOCUMENTS OR WHICH MEET SPECIFIED CRITERIA; BUSINESS RECORDS MANAGEMENT IN THE FIELD OF DOCUMENT DE-DUPLICATION SERVICES, NAMELY, IDENTIFYING AND GROUPING BUSINESS DOCUMENTS WHICH ARE IDENTICAL OR NEARLY IDENTICAL FOR FURTHER ANALYSIS OR RATIONALIZATION; BUSINESS RECORDS MANAGEMENT, NAMELY, PROVIDING BUSINESS DOCUMENT CONTENT INDEXING BASED ON THE ANALYSIS OF THE DOCUMENTS; BUSINESS RECORDS MANAGEMENT, NAMELY, PROVIDING DOCUMENT AUDITING SERVICES ENABLING A BUSINESS OR ORGANIZATION TO CREATE AN AUDIT TRAIL OF CHECKS AND PROCESSES THAT HAVE BEEN APPLIED TO BUSINESS DOCUMENTS TO RECORD COMPLIANCE; BUSINESS RECORDS MANAGEMENT, NAMELY, DOCUMENT CONSOLIDATION FOR THE MERGER OF BUSINESS DOCUMENTS TO CREATE A SINGLE DOCUMENT CONTAINING THE ESSENTIAL PARTS FROM THE ORIGINAL DOCUMENTS; BUSINESS RECORDS MANAGEMENT IN THE FIELD OF DOCUMENT VERIFICATION SERVICES, NAMELY, VERIFYING DOCUMENTS FOR ADHERENCE TO A BUSINESS OR ORGANIZATION'S STANDARDS; BUSINESS RECORDS MANAGEMENT, NAMELY, DOCUMENT COMPARISON SERVICES FOR THE COMPARISON OF BUSINESS DOCUMENTS AGAINST EACH OTHER OR AGAINST STANDARD FORMS; BUSINESS DATA ANALYSIS FOR BUSINESS OR ORGANIZATIONS; BUSINESS RECORDS MANAGEMENT, NAMELY, MERGING DOCUMENTS TO CREATE A SINGLE DOCUMENT CONTAINING THE ESSENTIAL PARTS FROM THE ORIGINAL DOCUMENTS; BUSINESS RECORDS MANAGEMENT, NAMELY, MATCHING DOCUMENTS AGAINST EACH

CLASS 35—(Continued).

OTHER OR AGAINST STANDARD FORMS; BUSINESS RECORDS MANAGEMENT, NAMELY, CATEGORIZING A BUSINESS OR ORGANISATIONS' DOCUMENTS ACCORDING TO CATEGORY OR SIMILARITY; BUSINESS RECORDS MANAGEMENT, NAMELY, CONSTRUCTING NEW BUSINESS DOCUMENTS BASED ON TEMPLATES AND SUPPLIED PARAMETERS; BUSINESS RECORDS MANAGEMENT IN THE FIELD OF DOCUMENT RATIONALISATION, NAMELY, SIMPLIFYING AND STANDARDIZING A SET OF BUSINESS DOCUMENTS BY MINIMIZING VARIATIONS IN WORDING AND STRUCTURE; BUSINESS CONSULTATION SERVICES IN THE FIELD OF BUSINESS REGULATION COMPLIANCE, NAMELY, ASSISTING A BUSINESS OR ORGANIZATION IN ANALYZING DOCUMENTS AND APPLYING THEIR OWN RULES, AS APPROPRIATE, TO INCREASE COMPLIANCE CERTAINTY WITHIN REGULATED FIELDS OF BUSINESS; NONE OF THE AFORESAID RELATING TO THE PROVISION OF ADVERTISING OR ADVERTISING RELATED SERVICES (U.S. CLS. 100, 101 AND 102).

FIRST USE 0-0-2007; IN COMMERCE 0-0-2007.
SKYE YOUNG, EXAMINING ATTORNEY

SN 85-151,650. AOL INC., DULLES, VA. FILED 10-13-2010.

MENSWIRE

THE MARK CONSISTS OF STANDARD CHARACTERS WITHOUT CLAIM TO ANY PARTICULAR FONT, STYLE, SIZE, OR COLOR.

PRIORITY CLAIMED UNDER SEC. 44(D) ON ERP CMNTY TM OFC APPLICATION NO. 9401506, FILED 9-24-2010, REG. NO. 9401506, DATED 3-8-2011, EXPIRES 9-24-2020.

FOR PROVIDING A WEBSITE FEATURING NEWS, INFORMATION, AND COMMENTARY IN THE FIELD OF POLITICS (U.S. CLS. 100, 101 AND 102).

KRISTINA MORRIS, EXAMINING ATTORNEY

SN 85-163,132. OVERSTOCK.COM, INC., SALT LAKE CITY, UT. FILED 10-27-2010.

Overstock.com Auctions

THE MARK CONSISTS OF STANDARD CHARACTERS WITHOUT CLAIM TO ANY PARTICULAR FONT, STYLE, SIZE, OR COLOR.

OWNER OF U.S. REG. NOS. 2,503,246, 2,939,764 AND 3,676,884.

NO CLAIM IS MADE TO THE EXCLUSIVE RIGHT TO USE "AUCTIONS", APART FROM THE MARK AS SHOWN. SEC. 2(F) AS TO "OVERSTOCK.COM".

FOR ON-LINE AUCTION SERVICES (U.S. CLS. 100, 101 AND 102).

MARLENE BELL, EXAMINING ATTORNEY

CLASS 35—(Continued).

SN 85-166,919. CITY AND COUNTY OF DENVER, DENVER, CO. FILED 11-2-2010.



NO CLAIM IS MADE TO THE EXCLUSIVE RIGHT TO USE "BALLOT" AND "TRACKING, REPORTING, AND COMMUNICATION ENGINE", APART FROM THE MARK AS SHOWN.

THE COLOR(S) BLUE, WHITE, BLACK, AND RED IS/ARE CLAIMED AS A FEATURE OF THE MARK.

THE MARK CONSISTS OF THREE LINES OF TEXT AND DESIGN AS FOLLOWS: THE FIRST LINE BEGINS WITH ONE SMALL SOLID BLUE FIVE (5) POINTED STAR FOLLOWED BY THE WORD "BALLOT" IN BLACK BLOCK LETTERS WHICH IS IMMEDIATELY FOLLOWED BY TWO COLUMNS OF RED, WHITE, AND RED SLIGHTLY CURVED STRIPES. THE SECOND LINE CONSISTS OF A LARGE FIVE (5) POINTED STAR WITH A BLUE BORDER AND WHITE CENTER. TO THE LEFT OF THE LARGE STAR IS A SMALL SOLID BLUE FIVE (5) POINTED STAR LOCATED BETWEEN THE FIFTH AND FIRST POINTS, CLOCKWISE. TO THE RIGHT OF THE LARGE STAR IS A MEDIUM SOLID BLUE FIVE (5) POINTED STAR LOCATED BETWEEN THE FIRST AND SECOND POINTS, CLOCKWISE. A SMALL SOLID BLUE FIVE (5) POINTED STAR IS LOCATED ON THE SECOND POINT TO THE RIGHT OF THE LARGE STAR. A MEDIUM SOLID BLUE FIVE (5) POINTED STAR IS LOCATED TO THE RIGHT OF THE LARGE STAR BETWEEN THE SECOND AND THIRD POINTS, CLOCKWISE, AND IS FOLLOWED BY THE WORD "TRACE" IN BLACK BLOCK LETTERS. THE THIRD LINE CONSISTS OF THE WORDS "TRACKING, REPORTING, AND COMMUNICATIONS ENGINE" IN BLACK BLOCK LETTERS.

FOR PROVIDING COMPUTERIZED MAIL-BALLOT TRACKING, REPORTING, COMMUNICATION, AND INFORMATION SERVICES CONCERNING THE TRACKING, REPORTING, AND COMMUNICATION OF MAIL ITEMS USING BAR CODES VIA A GLOBAL COMPUTER INFORMATION NETWORK (U.S. CLS. 100, 101 AND 102).

FIRST USE 10-1-2009; IN COMMERCE 10-1-2009.
MICHAEL WIENER, EXAMINING ATTORNEY

SN 85-168,064. CATHERINE MOUSSAZADEH, NEW YORK, NY. FILED 11-3-2010.

LIVE AND LET LIVE

THE MARK CONSISTS OF STANDARD CHARACTERS WITHOUT CLAIM TO ANY PARTICULAR FONT, STYLE, SIZE, OR COLOR.

FOR PROMOTING CHARITABLE GIVING THAT REFLECTS THE CORE VALUES OF THE DONOR BY PROVIDING A METHOD TO IDENTIFY THE DONOR'S CORE VALUES AND TO SELECT CHARITIES THAT FOSTER THOSE VALUES (U.S. CLS. 100, 101 AND 102).

FIRST USE 6-20-2008; IN COMMERCE 6-20-2008.
MARC LEIPZIG, EXAMINING ATTORNEY

CLASS 35—(Continued).

SN 85-172,351. MILLIKEN & COMPANY, SPARTANBURG, SC. FILED 11-9-2010.

OWNER OF U.S. REG. NOS. 896,986, 3,648,244 AND OTHERS.
 THE MARK CONSISTS OF "MILLIKEN" IN CURSIVE WRITING.
 SEC. 2(F).
 FOR MANAGEMENT AND BUSINESS CONSULTING SERVICES IN THE FIELD OF MANUFACTURING AND PERFORMANCE IMPROVEMENT; PROVIDING CONSUMER INFORMATION AND ADVISORY SERVICES IN THE FIELD OF SUSTAINABLE BUSINESS PRACTICES (U.S. CLS. 100, 101 AND 102).
 LINDA ESTRADA, EXAMINING ATTORNEY

SN 85-201,831. MCMULLEN, ANDREA L., SAN DIEGO, CA. FILED 12-20-2010.



NO CLAIM IS MADE TO THE EXCLUSIVE RIGHT TO USE "LEADERSHIP" "BREADTH OF LEADERSHIP CAPABILITY", "DEPTH OF EXPERTISE", "STRATEGIC AGILITY", "INNOVATIVE", "ENTREPRENEURIAL", "GLOBALLY-ORIENTED" AND "ADAPTABLE & RESILIENT", "AUTHENTIC", "ACCOUNTABLE", "INSPIRATIONAL", "COLLABORATIVE", "DEVELOPING & EMPOWERING OTHERS", "CUSTOMER FOCUSED", "MARKET DRIVEN", "DECISIVE", "PROACTIVE" & "RESULTS-BASED", AND "COMPETENCY & SKILLS BUILDING", "SCIENCE & ENGINEERING", "SALES", "MARKETING", "OPERATIONS", "INFORMATION TECHNOLOGY", "FINANCE", "BUSINESS DEVELOPMENT", "LEGAL", "HUMAN RESOURCES", "MANUFACTURING", "ETC.", APART FROM THE MARK AS SHOWN.

"A. MCMULLEN" IDENTIFIES A LIVING INDIVIDUAL WHOSE CONSENT IS OF RECORD.
 THE COLOR(S) BLACK, WHITE, BLUE, RED, GREEN, ORANGE AND GREY IS/ARE CLAIMED AS A FEATURE OF THE MARK.

THE MARK CONSISTS OF THE WORDING "NEXGEN LEADERSHIP & THE LEADERSHIP GENOME" IN THE COLOR BLACK ABOVE THE NAME "MCMULLEN, A. 2010" IN PARENTHESES IN BLACK AND A T-SHAPE WITH A HORIZONTAL DIMENSION ENTITLED THE "BREADTH OF LEADERSHIP CAPABILITY", IN BETWEEN OPPOSING ARROWS IN GREY ABOVE A BLUE BOX WITH THE WORDS "THOUGHT LEADERSHIP" IN WHITE AND BENEATH THE WORDING "STRATEGIC AGILITY", "INNOVATIVE", "ENTREPRENEURIAL", "GLOBALLY-ORIENTED" AND "ADAPTABLE & RESILIENT" IN BULLET FORM AND ALL IN THE COLOR WHITE; A RED BOX IN THE CENTER WITH THE WORDS "PEOPLE LEADERSHIP" IN WHITE AND BENEATH THE WORDING "AUTHENTIC", "ACCOUNTABLE", "INSPIRATIONAL",

CLASS 35—(Continued).

"COLLABORATIVE", "DEVELOPING & EMPOWERING OTHERS" IN BULLET FORM AND ALL IN THE COLOR WHITE; AND GREEN BOX ON THE FAR RIGHT WITH THE WORDS "RESULTS LEADERSHIP" IN WHITE AND BENEATH THE WORDING "CUSTOMER FOCUSED", "MARKET DRIVEN", "DECISIVE", "PROACTIVE" AND "RESULTS-BASED" IN BULLET FORM AND ALL IN THE COLOR WHITE. THE VERTICAL DIMENSION OF THE T-SHAPE FEATURES THE WORDS "DEPTH OF EXPERTISE" IN GREY BETWEEN OPPOSING ARROWS IN GREY AND IS TO THE LEFT OF AN ORANGE BOX WITH THE WORDS "FUNCTIONAL LEADERSHIP: COMPETENCY & SKILLS BUILDING" IN BLACK AND BENEATH THE WORDING "SCIENCE & ENGINEERING", "SALES", "MARKETING", "OPERATIONS", "INFORMATION TECHNOLOGY", "FINANCE", "BUSINESS DEVELOPMENT", "LEGAL", "HUMAN RESOURCES", "MANUFACTURING", "ETC" IN BULLET FORM AND ALL IN THE COLOR BLACK. A FANCIFUL LADDER DESIGN IN BLUE AND YELLOW APPEARS TO THE LEFT OF THE T-SHAPE. THE MARK APPEARS ON A WHITE BACKGROUND WITH A BLUE WAVE DESIGN IMMEDIATELY ABOVE AND BELOW.

FOR BUSINESS MANAGEMENT CONSULTING WITH RELATION TO STRATEGY, MARKETING, SALES, OPERATION, PRODUCT DESIGN PARTICULARLY SPECIALIZING IN THE USE OF ANALYTIC AND STATISTIC MODELS FOR THE UNDERSTANDING AND PREDICTING OF CONSUMERS, BUSINESSES, AND MARKET TRENDS AND ACTIONS; CONSUMER STRATEGY BUSINESS CONSULTING IN THE FIELDS OF MARKETING, SALES, OPERATION, AND PRODUCT DESIGN PARTICULARLY SPECIALIZING IN THE USE OF ANALYTIC MODELS FOR THE UNDERSTANDING AND PREDICTING OF CONSUMER, BUSINESS, AND RETAIL MARKET TRENDS AND ACTIONS (U.S. CLS. 100, 101 AND 102).
 KIMBERLY PERRY, EXAMINING ATTORNEY

SN 85-211,883. HWA FUNDRAISING, LLC, PORTSMOUTH, NH. FILED 1-6-2011.



THE COLOR(S) YELLOW, BLUE, RED, BLACK, AND WHITE IS/ARE CLAIMED AS A FEATURE OF THE MARK.
 THE MARK CONSISTS OF A STYLIZED SCHOOL BUS. THE COLOR YELLOW APPEARS IN THE BODY OF THE BUS. THE COLOR BLUE APPEARS IN THE WINDOWS OF THE BUS. THE COLOR RED APPEARS IN THE LIGHTS ON THE FRONT OF THE BUS. THE COLOR BLACK APPEARS ON THE TIRES, GRILL, AND BACKGROUND. THE COLOR WHITE APPEARS IN GRADIENT FORM ON THE GRILL, TIRES, AND WINDOWS.
 FOR BUSINESS CONSULTATION SERVICES TO ASSIST NON-PROFIT ORGANIZATIONS IN PLANNING, MANAGING, AND CONDUCTING FUNDRAISING ACTIVITIES VIA A GLOBAL COMPUTER NETWORK (U.S. CLS. 100, 101 AND 102).
 DANNEAN HETZEL, EXAMINING ATTORNEY

CLASS 35—(Continued).

SN 85-212,788. MIDWEST DAIRY ASSOCIATION, ST. PAUL, MN. FILED 1-7-2011.



NO CLAIM IS MADE TO THE EXCLUSIVE RIGHT TO USE "ASSOCIATION", APART FROM THE MARK AS SHOWN.

THE MARK CONSISTS OF A STYLIZED DRAWING OF A GLASS OF MILK WITH A SMALLER STYLIZED DRAWING OF A BOWL OF YOGURT POSITIONED TO BE SLIGHTLY OVERLAPPING THE CENTER LEFT SIDE OF THE GLASS AND A SMALLER STYLIZED DRAWING OF A WHEEL OF CHEESE, WITH A TRIANGLE MISSING, POSITIONED TO BE SLIGHTLY OVERLAPPING THE CENTER RIGHT SIDE OF THE GLASS WITH THE STYLIZED WORD "MIDWEST" HORIZONTALLY-POSITIONED ACROSS THE MIDDLE OF THE DRAWING FOLLOWED BY THE WORD "DAIRY" AND THE STYLIZED WORD "ASSOCIATION" APPEARING BELOW THE WORD "DAIRY" IN CAPITAL LETTERS.

SEC. 2(F) AS TO MIDWEST DAIRY ASSOCIATION.

FOR ASSOCIATION SERVICES, NAMELY, PROMOTING THE INTEREST AND WELL-BEING OF DAIRY PRODUCERS (U.S. CLS. 100, 101 AND 102).

FIRST USE 10-1-2009; IN COMMERCE 10-1-2009.

JULIE VEPPUMTHARA, EXAMINING ATTORNEY

CLASS 35—(Continued).

SN 85-242,482. CHRISTY SPORTS, LLC, LAKEWOOD, CO. FILED 2-15-2011.

POWDER DAZE

THE MARK CONSISTS OF STANDARD CHARACTERS WITHOUT CLAIM TO ANY PARTICULAR FONT, STYLE, SIZE, OR COLOR.

FOR RETAIL STORE SERVICES AND ARRANGING AND CONDUCTING COMMERCIAL RETAIL EVENTS FEATURING SKI AND SNOWBOARD GEAR AND APPAREL (U.S. CLS. 100, 101 AND 102).

FIRST USE 8-20-2009; IN COMMERCE 8-20-2009.

JANICE L. MCMORROW, EXAMINING ATTORNEY

SN 85-247,362. CALIFORNIA UTILITIES EMERGENCY ASSOCIATION, MATHER, CA. FILED 2-21-2011.

SN 85-217,516. VHQC, DBA VIRGINIA HEALTH QUALITY COMPANY, RICHMOND, VA. FILED 1-13-2011.



THE COLOR(S) BLUE IS/ARE CLAIMED AS A FEATURE OF THE MARK.

THE MARK CONSISTS OF BLUE CAPITALS LETTERS SPELLING OUT "VHQC", WITH A LINE UNDER THE LETTERS "V", "H" AND "C". ABOVE THE LETTERS APPEARS A BLUE SQUARE WHERE LINES ARE CUT OUT FROM WITHIN THE SQUARE TO FORM A "Q". THE COLOR WHITE IS TRANSPARENT BACKGROUND AND IS NOT CLAIMED AS A FEATURE OF THE MARK.

FOR BUSINESS CONSULTING AND INFORMATION SERVICES (U.S. CLS. 100, 101 AND 102).

FIRST USE 1-1-2000; IN COMMERCE 1-1-2000.

CHARLOTTE CORWIN, EXAMINING ATTORNEY



NO CLAIM IS MADE TO THE EXCLUSIVE RIGHT TO USE "CALIFORNIA UTILITIES EMERGENCY ASSOCIATION" AND THE REPRESENTATION OF THE STATE OF CALIFORNIA, APART FROM THE MARK AS SHOWN.

THE COLOR(S) COBALT BLUE AND DARK TANGERINE IS/ARE CLAIMED AS A FEATURE OF THE MARK.

THE MARK CONSISTS OF A DARK TANGERINE COLORED SILHOUETTE OF THE STATE OF CALIFORNIA, THE LOWER RIGHT PORTION OF WHICH IS SURROUNDED BY LIGHT RAYS IN COBALT BLUE COLOR, ALL OF WHICH IS ACCOMPANIED BY THE WORDS "CALIFORNIA UTILITIES EMERGENCY ASSOCIATION" WITH THE WORDS "CALIFORNIA" AND "ASSOCIATION" IN DARK TANGERINE COLOR, AND THE WORDS "UTILITIES" AND "EMERGENCY" IN COBALT BLUE COLOR.

FOR ASSOCIATION SERVICES, NAMELY, PROMOTING THE INTERESTS OF EMERGENCY SERVICE ORGANIZATIONS, COMPOSED OF UTILITY COMPANIES, IN ENHANCING EMERGENCY PLANNING BY PREPARING AND RESPONDING TO EMERGENCIES THROUGH MITIGATION, COMMUNICATION, RESPONSE AND RESTORATION OF SERVICES (U.S. CLS. 100, 101 AND 102).

FIRST USE 1-10-2008; IN COMMERCE 1-31-2008.

HENRY S. ZAK, EXAMINING ATTORNEY

CLASS 35—(Continued).

SN 85-247,826. PAPERKING INC., WORCESTER, MA. FILED 2-22-2011.

HALLOWEEN OUTLET

THE MARK CONSISTS OF STANDARD CHARACTERS WITHOUT CLAIM TO ANY PARTICULAR FONT, STYLE, SIZE, OR COLOR.

OWNER OF U.S. REG. NO. 2,123,957.

NO CLAIM IS MADE TO THE EXCLUSIVE RIGHT TO USE "OUTLET", APART FROM THE MARK AS SHOWN. SEC. 2(F).

FOR RETAIL STORE SERVICES FEATURING HALLOWEEN AND HALLOWEEN RELATED ITEMS (U.S. CLS. 100, 101 AND 102).

FIRST USE 10-1-1989; IN COMMERCE 10-1-1989.

DEZMONA MIZELLE, EXAMINING ATTORNEY

SN 85-252,052. 9001-6262 QUÉBEC INC., SAINT-AUGUSTIN-DE-DESMAURES, CANADA, FILED 2-25-2011.

GARNEAU CONCEPT

THE MARK CONSISTS OF STANDARD CHARACTERS WITHOUT CLAIM TO ANY PARTICULAR FONT, STYLE, SIZE, OR COLOR.

PRIORITY CLAIMED UNDER SEC. 44(D) ON CANADA APPLICATION NO. 1494087, FILED 8-30-2010, REG. NO. TMA811137, DATED 11-4-2011, EXPIRES 11-4-2026.

OWNER OF U.S. REG. NOS. 3,374,468 AND 3,805,346.

FOR RETAIL STORE SERVICES FEATURING SPORTS AND OUTDOOR CLOTHING, PRODUCTS AND ACCESSORIES (U.S. CLS. 100, 101 AND 102).

RAMONA ORTIGA, EXAMINING ATTORNEY

SN 85-252,701. ABC GIFT CARDS LLC, EAST WINDSOR, NJ. FILED 2-26-2011.

CardCash

THE MARK CONSISTS OF STANDARD CHARACTERS WITHOUT CLAIM TO ANY PARTICULAR FONT, STYLE, SIZE, OR COLOR.

FOR RETAIL AND ONLINE RETAIL STORE SERVICES FEATURING GIFT CARDS, MERCHANDISE CREDIT, PRE-PAID CARDS, CREDIT, DEBIT, SPORTING AND ENTERTAINMENT CARDS; OPERATING ONLINE MARKETPLACES WHERE USERS BUY, SELL, AND SWAP PRE-OWNED AND NEW CARDS (U.S. CLS. 100, 101 AND 102).

FIRST USE 1-1-2008; IN COMMERCE 1-1-2008.

AISHA SALEM, EXAMINING ATTORNEY

CLASS 35—(Continued).

SN 85-258,997. FOOD MERCHANTS, LLC, DBA ALPS DISCOUNT PHARMACY, NIXA, MO. FILED 3-5-2011.



NO CLAIM IS MADE TO THE EXCLUSIVE RIGHT TO USE "DISCOUNT PHARMACY ALWAYS LOW PRICES", APART FROM THE MARK AS SHOWN.

THE COLOR(S) BLACK, GREEN, YELLOW AND BLUE IS/ARE CLAIMED AS A FEATURE OF THE MARK.

THE MARK CONSISTS OF THE WORDING "ALPS DISCOUNT PHARMACY" IN BLACK, "ALWAYS LOW PRICES" IN GREEN, ALL BENEATH A DESIGN OF THREE STYLIZED CAPSULES IN YELLOW, BLUE AND GREEN, FROM LEFT TO RIGHT.

FOR PHARMACEUTICAL SERVICES, NAMELY, PROCESSING ONLINE AND TELEPHONE PRESCRIPTION ORDERS IN RETAIL AND CENTRAL FILL PHARMACIES (U.S. CLS. 100, 101 AND 102).

FIRST USE 2-7-2004; IN COMMERCE 2-7-2004.

FRED CARL, EXAMINING ATTORNEY

SN 85-267,678. BIDTRASH, LLC, TEANECK, NJ. FILED 3-15-2011.



THE MARK CONSISTS OF THE WORD "BIDTRASH" IN STYLIZED LETTERS. A PICTURE OF A SMALL TRASH CAN COMPRISED OF A STYLIZED LETTER "B" APPEARS ON A SIGN TO THE LEFT OF THE WORD.

FOR PROVIDING A WEB SITE WHERE RUBBISH AND WASTE COLLECTION COMPANIES PROVIDE COMPETITIVE PRICE QUOTATIONS TO HOMEOWNERS AND BUSINESSES FOR THEIR WASTE REMOVAL AND RECYCLING SERVICES (U.S. CLS. 100, 101 AND 102).

KAREN BRACEY, EXAMINING ATTORNEY

CLASS 35—(Continued).

SN 85-267,916. NATIONAL HISPANIC CHAMBER OF COMMERCE ON HEALTH, NEW YORK, NY. FILED 3-15-2011.



NO CLAIM IS MADE TO THE EXCLUSIVE RIGHT TO USE "CHAMBER OF COMMERCE". THE DESIGN OF THE CADUCEUS, THE TRAFFIC SIGN SYMBOL OF THE "H" IN A SQUARE, AND "RX", APART FROM THE MARK AS SHOWN.

THE MARK CONSISTS OF THE STYLIZED WORDING "NATIONAL HISPANIC CHAMBER OF COMMERCE ON HEALTH" WITHIN CONCENTRIC CIRCLES. WITHIN THE CIRCLES IS A SEAL DESIGN COMPRISED OF A FLATTENED GLOBE WITH A LAUREL WREATH. IN THE CENTER OF THE GLOBE IS A SHIELD WITH THE STYLIZED WORDING "NHCCH", A CADUCEUS, THE LETTER "H" WHICH IS THE TRAFFIC SIGN SYMBOL FOR A HOSPITAL, THE SILHOUETTES OF A MAN, WOMAN, AND CHILD, AND A MORTAR AND PESTLE WITH AN "RX".

SEC. 2(F) AS TO "NATIONAL HISPANIC CHAMBER OF COMMERCE ON HEALTH".

FOR CHAMBER OF COMMERCE SERVICES, NAMELY, PROMOTING BUSINESS DEVELOPMENT IN THE HOSPITAL, PHARMACEUTICAL, MANAGED CARE, INSURANCE, AND HEALTHCARE SECTORS (U.S. CLS. 100, 101 AND 102).

FIRST USE 5-1-2005; IN COMMERCE 5-1-2005.
KIM SAITO, EXAMINING ATTORNEY

SN 85-268,026. EDWARDS, BYRAN, COLLEGE PARK, GA. FILED 3-16-2011.

Home Team Apparel

THE MARK CONSISTS OF STANDARD CHARACTERS WITHOUT CLAIM TO ANY PARTICULAR FONT, STYLE, SIZE, OR COLOR.

NO CLAIM IS MADE TO THE EXCLUSIVE RIGHT TO USE "APPAREL", APART FROM THE MARK AS SHOWN.

FOR RETAIL STORE SERVICES FEATURING PROMOTIONAL ITEMS CUSTOM DESIGNED TO CUSTOMER SPECIFICATIONS, NAMELY, ARTICLES OF CLOTHING, OFFICE ACCESSORIES, SPORTING GOODS, AWARDS, BANNERS, SIGNS, COMPUTER ACCESSORIES, MOUSE PADS, T-SHIRTS, BIBS, CAPS, HEADWEAR, BANDANAS, HATS, JACKETS, SWEATSHIRTS, GOLF ATTIRE, BAGS, COASTERS, PUZZLES, CAR FLAGS WITH POLE, TOWELS, CAN WRAPS AND INSULATED SLEEVE HOLDERS FOR BEVERAGE CANS, NOT INCLUDING FOOTWEAR FOR MEN AND WOMEN (U.S. CLS. 100, 101 AND 102).

FIRST USE 11-5-2010; IN COMMERCE 11-5-2010.
LINDSEY RUBIN, EXAMINING ATTORNEY

CLASS 35—(Continued).

SN 85-268,745. GENERATION I.D.E.A. CONSULTING, LLC, FARGO, ND. FILED 3-16-2011.

KOTIKITES AND WINDSPORTS

THE MARK CONSISTS OF STANDARD CHARACTERS WITHOUT CLAIM TO ANY PARTICULAR FONT, STYLE, SIZE, OR COLOR.

NO CLAIM IS MADE TO THE EXCLUSIVE RIGHT TO USE "WINDSPORTS", APART FROM THE MARK AS SHOWN.

FOR RETAIL STORE SERVICES FEATURING WINDSPORTS EQUIPMENT AND SPORTS EQUIPMENT (U.S. CLS. 100, 101 AND 102).

EDWARD NELSON, EXAMINING ATTORNEY

SN 85-268,822. GENERATION I.D.E.A. CONSULTING, LLC, FARGO, ND. FILED 3-16-2011.



NO CLAIM IS MADE TO THE EXCLUSIVE RIGHT TO USE "KITES" AND "WIND SPORTS", APART FROM THE MARK AS SHOWN.

THE MARK CONSISTS OF A CAPITAL "K" AND A BACKWARDS CAPITAL "K" WITH A KITE TAIL WITHIN A DIAMOND SHAPE TO THE LEFT OF THE STYLIZED TERM "KOTIKITES" ABOVE THE PHRASE "AND WIND SPORTS".

FOR RETAIL STORE SERVICES FEATURING WINDSPORTS EQUIPMENT AND SPORTS EQUIPMENT (U.S. CLS. 100, 101 AND 102).

EDWARD NELSON, EXAMINING ATTORNEY

CLASS 35—(Continued).

SN 85-272,595. IDN, INC., GRAPEVINE, TX. FILED 3-21-2011.

IDN-H. HOFFMAN

THE MARK CONSISTS OF STANDARD CHARACTERS WITHOUT CLAIM TO ANY PARTICULAR FONT, STYLE, SIZE, OR COLOR.

OWNER OF U.S. REG. NO. 3,915,375.

FOR BUSINESS MANAGEMENT AND MARKETING, NAMELY, ADVERTISING AND PROMOTING THE GOODS OF OTHERS; PROCUREMENT SERVICES, NAMELY, PURCHASING LOCKS AND STRUCTURAL PARTS THEREFOR, ELECTRONIC LOCKS AND ACCESS CONTROL DEVICES, KEYS, KEY ACCESSORIES, ELECTRONIC SECURITY PRODUCTS, EXIT DEVICES AND ALARMS, PADLOCKS, METAL SAFES AND SAFE LOCKS, AND HYDRAULIC DOOR CLOSERS; WHOLESALE DISTRIBUTION OF LOCKS AND STRUCTURAL PARTS THEREFOR, ELECTRONIC LOCKS AND ACCESS CONTROL DEVICES, KEYS, KEY ACCESSORIES, ELECTRONIC SECURITY PRODUCTS, EXIT DEVICES AND ALARMS, PADLOCKS, METAL SAFES AND SAFE LOCKS, AND HYDRAULIC DOOR CLOSERS (U.S. CLS. 100, 101 AND 102).

FIRST USE 7-5-1995; IN COMMERCE 8-31-1995.

NORA BUCHANAN WILL, EXAMINING ATTORNEY

CLASS 35—(Continued).

SN 85-278,588. LIVING IN DIGITAL TIMES, LLC, NEW YORK, NY. FILED 3-28-2011.

LIVING IN DIGITAL TIMES

THE MARK CONSISTS OF STANDARD CHARACTERS WITHOUT CLAIM TO ANY PARTICULAR FONT, STYLE, SIZE, OR COLOR.

FOR CONDUCTING, ARRANGING AND ORGANIZING TRADE SHOWS AND TRADE FAIRS FOR COMMERCIAL AND ADVERTISING PURPOSES; PROMOTING AND CONDUCTING TRADE SHOWS IN THE FIELDS OF TECHNOLOGY AND FASHION; TRADE SHOW MANAGEMENT SERVICES; ORGANIZING OF BUSINESS COMPETITIONS; ORGANIZING TECHNOLOGY COMPETITIONS FOR BUSINESS PURPOSES; CONTESTS AND INCENTIVE AWARD PROGRAMS TO PROMOTE THE SALE OF PRODUCTS AND SERVICES OF OTHERS; ADVERTISING, MARKETING, AND PUBLICITY SERVICES; BUSINESS CONSULTING AND INFORMATION SERVICES; MARKETING CONSULTING SERVICES; FASHION SHOW EXHIBITIONS FOR COMMERCIAL PURPOSES; PROMOTION, ADVERTISING AND MARKETING OF ON-LINE WEBSITES (U.S. CLS. 100, 101 AND 102).

KIM SAITO, EXAMINING ATTORNEY

SN 85-282,079. SENTIENT SERVICES, LP, AUSTIN, TX. FILED 3-31-2011.

ICANMAKEITBETTER

THE MARK CONSISTS OF STANDARD CHARACTERS WITHOUT CLAIM TO ANY PARTICULAR FONT, STYLE, SIZE, OR COLOR.

FOR BUSINESS CONSULTATION AND MANAGEMENT REGARDING MARKETING ACTIVITIES AND LAUNCHING OF NEW PRODUCTS; BUSINESS CONSULTATION IN THE FIELD OF MARKETING RESEARCH AS IT RELATES TO PRODUCT DEVELOPMENT, BRANDING, MARKETING, AND ADVERTISING; BUSINESS RESEARCH AND SURVEYS; BUSINESS RESEARCH CONSULTATION; BUSINESS RESEARCH SERVICES IN THE FIELD OF MARKETING RESEARCH AS IT RELATES TO PRODUCT DEVELOPMENT, BRANDING, MARKETING, AND ADVERTISING; BUSINESS RESEARCH USING FOCUS GROUPS; BUSINESS SERVICES, NAMELY, CONSUMER RESEARCH AND CONSULTING RELATED THERETO; COLLECTION OF MARKET RESEARCH INFORMATION; COMPUTER-ASSISTED BUSINESS INFORMATION AND RESEARCH SERVICES; COMPUTERIZED MARKET RESEARCH SERVICES; CONDUCTING BUSINESS AND MARKET RESEARCH SURVEYS; CONDUCTING ON-LINE BUSINESS MANAGEMENT RESEARCH SURVEYS; CONSUMER MARKETING RESEARCH AND CONSULTING RELATED THERETO; MARKET ANALYSIS AND RESEARCH SERVICES; MARKET RESEARCH STUDIES; ONLINE BUSINESS RESEARCH SERVICES THAT ALLOW USERS TO SHARE OPINIONS WITH A MARKETING RESEARCH COMPANY RELATED TO EVERYDAY CONSUMER PRODUCTS AND SERVICES (U.S. CLS. 100, 101 AND 102).

ZACHARY BELLO, EXAMINING ATTORNEY

SN 85-276,533. WOODWORKER'S SUPPLY INC., CASPER, WY. FILED 3-25-2011.

PRO.WOODWORKER.COM

THE MARK CONSISTS OF STANDARD CHARACTERS WITHOUT CLAIM TO ANY PARTICULAR FONT, STYLE, SIZE, OR COLOR.

OWNER OF U.S. REG. NOS. 1,544,938, 1,637,203 AND 3,824,709.

SEC. 2(F).

FOR RETAIL STORE SERVICES, ON-LINE RETAIL STORE SERVICES, AND CATALOG ORDERING SERVICES, FEATURING WOODWORKING TOOLS, EQUIPMENT, AND SUPPLIES (U.S. CLS. 100, 101 AND 102).

FIRST USE 7-0-2005; IN COMMERCE 7-0-2005.

JESSICA A. POWERS, EXAMINING ATTORNEY

CLASS 35—(Continued).

SN 85-284,362. DAS DISTRIBUTORS, INC., PALMYRA, PA. FILED 4-1-2011.

**RIGHT PRODUCTS. RIGHT
PLACE. RIGHT NOW.**

THE MARK CONSISTS OF STANDARD CHARACTERS WITHOUT CLAIM TO ANY PARTICULAR FONT, STYLE, SIZE, OR COLOR.

FOR MAIL ORDER CATALOG, ONLINE ORDERING, AND WHOLESALE DISTRIBUTORSHIPS FEATURING VEHICLE ACCESSORIES FOR CAMPERS, BOATS, AND ON AND OFF ROAD VEHICLES (U.S. CLS. 100, 101 AND 102).

JOHN KELLY, EXAMINING ATTORNEY

CLASS 35—(Continued).

SN 85-288,396. THE BOX SAVERS, INC., GLENDALE, CA. FILED 4-6-2011.



THE MARK CONSISTS OF AN OUTLINE OF A CONTAINER/BOX WITH THE PHRASE "THE BOX SAVERS" EMBEDDED WITHIN.

FOR COMPUTERIZED ON-LINE ORDERING SERVICES IN THE FIELD OF MOVING AND RELOCATION.; MOVING AND RELOCATION SERVICES, NAMELY, PLANNING AND IMPLEMENTING MOVES OF HOMES AND OFFICES (U.S. CLS. 100, 101 AND 102). FIRST USE 8-28-2010; IN COMMERCE 8-28-2010.

GINA HAYES, EXAMINING ATTORNEY

SN 85-290,269. CLICK SALES INC., BOISE, ID. FILED 4-8-2011.

SOCIALPROMOTE

SN 85-287,015. GEORGIA HEALTH CARE ASSOCIATION, STOCKBRIDGE, GA. FILED 4-5-2011.



THE MARK CONSISTS OF STANDARD CHARACTERS WITHOUT CLAIM TO ANY PARTICULAR FONT, STYLE, SIZE, OR COLOR.

FOR ADVERTISING AND MARKETING SERVICES IN THE FIELD OF E-COMMERCE FOR PROMOTING THE GOODS AND SERVICES OF OTHERS VIA SOCIAL MARKETING NETWORKS (U.S. CLS. 100, 101 AND 102). FIRST USE 2-0-2011; IN COMMERCE 2-0-2011.

BARBARA A. GOLD, EXAMINING ATTORNEY

SN 85-290,656. SANLUIS CORPORACIÓN, S.A.B DE C.V., MEXICO, D.F., MEXICO, FILED 4-8-2011.



NO CLAIM IS MADE TO THE EXCLUSIVE RIGHT TO USE "ASSOCIATION", APART FROM THE MARK AS SHOWN.

THE MARK CONSISTS OF THE TERM "GHCA" IN FRONT OF AN IMAGE OF THE STATE OF GEORGIA, TO THE RIGHT OF WHICH IS THE TERM "GEORGIA HEALTH CARE ASSOCIATION". THERE IS A CROSS BETWEEN THE "H" AND THE "C" IN "GHCA".

SEC. 2(F).

FOR ASSOCIATION SERVICES, NAMELY, PROMOTING THE INTERESTS OF LONG TERM AND POST-ACUTE CARE PROVIDERS AND ADVOCATING FOR CARE AND SERVICES FOR FRAIL, ELDERLY, AND DISABLED INDIVIDUALS (U.S. CLS. 100, 101 AND 102).

FIRST USE 1-0-2005; IN COMMERCE 1-0-2005.

INGA ERVIN, EXAMINING ATTORNEY

OWNER OF MEXICO REG. NO. 609237, DATED 5-12-1999, EXPIRES 2-25-2019.

OWNER OF U.S. REG. NOS. 3,979,922 AND 4,030,697.

THE MARK CONSISTS OF A RECTANGLE WITH CURVED LINES NEXT TO THE WORDS "SANLUIS RASSINI".

THE WORDING "SANLUIS RASSINI" HAS NO MEANING IN A FOREIGN LANGUAGE.

FOR ADVERTISING SERVICES, BUSINESS MANAGEMENT, BUSINESS ADMINISTRATION CONSULTANCY, PROVIDING OFFICE FUNCTIONS, ORGANIZATION OF EXHIBITIONS WITH COMMERCIAL PURPOSES; WHOLESALE DISTRIBUTORSHIP FEATURING AUTO-PARTS (U.S. CLS. 100, 101 AND 102).

PAM WILLIS, EXAMINING ATTORNEY

CLASS 35—(Continued).

SN 85-291,000. MOLLY BRANDENBERGER, DBA MS PARTY GIRL, ATLANTA, GA. FILED 4-9-2011.

Ms Party Girl

THE MARK CONSISTS OF STANDARD CHARACTERS WITHOUT CLAIM TO ANY PARTICULAR FONT, STYLE, SIZE, OR COLOR.

FOR ENTERTAINMENT MARKETING SERVICES, NAMELY, MARKETING, PROMOTION AND ADVERTISING FOR INDEPENDENT RECORDING ARTISTS; ENTERTAINMENT MARKETING SERVICES, NAMELY, MARKETING, PROMOTION AND ADVERTISING FOR RECORDING AND PERFORMING ARTISTS; EVENT PLANNING AND MANAGEMENT FOR MARKETING, BRANDING, PROMOTING OR ADVERTISING THE GOODS AND SERVICES OF OTHERS; PROMOTING THE PARTIES AND SPECIAL EVENTS OF OTHERS (U.S. CLS. 100, 101 AND 102).

FIRST USE 4-8-2011; IN COMMERCE 4-8-2011.
SHAUNIA CARLYLE, EXAMINING ATTORNEY

SN 85-291,855. IDEAS IN COLOR, SAN ANTONIO, TX. FILED 4-11-2011.

Ideas in Color

THE MARK CONSISTS OF STANDARD CHARACTERS WITHOUT CLAIM TO ANY PARTICULAR FONT, STYLE, SIZE, OR COLOR.

FOR ADVERTISING AND MARKETING SERVICES, NAMELY, PROMOTING THE GOODS AND SERVICES OF OTHERS (U.S. CLS. 100, 101 AND 102).

FIRST USE 12-4-2008; IN COMMERCE 12-4-2008.
CAROLINE WOOD, EXAMINING ATTORNEY

SN 85-294,742. POAGE, DAVID ALAN, SYLVANIA, OH. FILED 4-13-2011.

DAEDALEAN

THE MARK CONSISTS OF STANDARD CHARACTERS WITHOUT CLAIM TO ANY PARTICULAR FONT, STYLE, SIZE, OR COLOR.

FOR BUSINESS CONSULTING SERVICES IN THE FIELD OF QUALITY SCIENCES, NAMELY, LEAN SIX-SIGMA, QUALITY MANAGEMENT, QUALITY ENGINEERING, AND QUALITY AUDITING FOR COMPANIES IN SERVICING AND MANUFACTURING INDUSTRIES (U.S. CLS. 100, 101 AND 102).

FIRST USE 1-3-2011; IN COMMERCE 1-3-2011.
SHANNON TWOHIG, EXAMINING ATTORNEY

CLASS 35—(Continued).

SN 85-297,430. TIOGA PIPE SUPPLY COMPANY, INC., PHILADELPHIA, PA. FILED 4-18-2011.

TIOGA PIPE

THE MARK CONSISTS OF STANDARD CHARACTERS WITHOUT CLAIM TO ANY PARTICULAR FONT, STYLE, SIZE, OR COLOR.

OWNER OF U.S. REG. NOS. 1,506,547 AND 1,506,548.

NO CLAIM IS MADE TO THE EXCLUSIVE RIGHT TO USE "PIPE", APART FROM THE MARK AS SHOWN. SEC. 2(F).

FOR DISTRIBUTORSHIP SERVICES IN THE FIELD OF PIPES, STEEL PLATES AND SHEETS, METAL FASTENERS, METAL RODS, METAL FORGINGS, CASTING ALLOYS, CARBON, STAINLESS AND CHROME ALLOY, SPECIALTY ALLOYS AND METALS, TUBULAR PRODUCTS, FITTINGS AND FLANGES MANUFACTURED BY OTHERS (U.S. CLS. 100, 101 AND 102).

FIRST USE 7-0-2010; IN COMMERCE 7-0-2010.
SUE LAWRENCE, EXAMINING ATTORNEY

SN 85-298,115. TRACTION CORPORATION, SAN FRANCISCO, CA. FILED 4-18-2011.



THE MARK CONSISTS OF A STYLIZED LETTER "T" INSIDE A CIRCLE.

FOR INTERACTIVE AGENCY SERVICES FEATURING THE DEVELOPMENT OF INTERACTIVE WEBSITES, SEARCH ENGINE MARKETING CAMPAIGNS AND E-COMMERCE CONSULTING FOR USE BY OTHERS IN PROVIDING FOR THE DELIVERY OF SPECIALIZED ADVERTISING AND MARKETING SERVICES VIA MULTI-MEDIA ENABLED ELECTRONIC BASED DIGITAL SPACE PLATFORMS, AND CONSULTING SERVICES IN CONNECTION THEREWITH (U.S. CLS. 100, 101 AND 102).

FIRST USE 9-25-2001; IN COMMERCE 9-25-2001.
RUSS HERMAN, EXAMINING ATTORNEY

CLASS 35—(Continued).

SN 85-298,909. MATSUDAIRA, DAVID K., PEWAUKEE, WI. FILED 4-19-2011.



NO CLAIM IS MADE TO THE EXCLUSIVE RIGHT TO USE "FINE MEN'S APPAREL", APART FROM THE MARK AS SHOWN.

THE MARK CONSISTS OF DESIGN COMPRISED OF OFFSET CURVES OF A STYLIZED LETTER "S" SUPERIMPOSED OVER A VERTICALLY ORIENTED BARREL SHAPED RECTANGLE TOGETHER WITH THE WORDS SQUIRE FINE MEN'S APPAREL.

FOR BOUTIQUE RETAIL STORE SERVICES FEATURING FINE MEN'S CLOTHING (U.S. CLS. 100, 101 AND 102).

MARK SPARACINO, EXAMINING ATTORNEY

SN 85-301,642. UNITEDHEALTH GROUP INCORPORATED, MINNETONKA, MN. FILED 4-21-2011.

UNITEDHEALTHCARE

THE MARK CONSISTS OF STANDARD CHARACTERS WITHOUT CLAIM TO ANY PARTICULAR FONT, STYLE, SIZE, OR COLOR.

OWNER OF U.S. REG. NOS. 1,967,622, 3,269,588 AND OTHERS.

FOR COST MANAGEMENT SERVICES FOR HEALTH CARE BENEFIT AND DISABILITY PLANS OF OTHERS; COST MANAGEMENT OF VISION BENEFIT PLANS OF OTHERS; COST MANAGEMENT SERVICES FOR PHARMACY BENEFIT AND PRESCRIPTION DRUG BENEFIT PLANS OF OTHERS; COST MANAGEMENT THROUGH APPROPRIATENESS AND TECHNOLOGY ASSESSMENT FOR TRANSPLANTATION PLAN BENEFITS; HEALTH CARE UTILIZATION AND REVIEW SERVICES; HEALTH CARE COST CONTAINMENT; MANAGED CARE SERVICES, NAMELY, ELECTRONIC PROCESSING OF HEALTH CARE INFORMATION; EMPLOYEE ASSISTANCE PROGRAMS CONSISTING OF REFERRAL SERVICES TO ASSIST EMPLOYEES WITH PERSONAL PROBLEMS; EMPLOYEE ASSISTANCE SERVICES, NAMELY, PROVIDING ONLINE, TELEPHONIC, AND IN-PERSON REFERRAL SERVICES FOR PHYSICAL, AND MENTAL HEALTH, AND SUBSTANCE ABUSE AND PROVIDING CONSULTATION, INFORMATION AND ASSESSMENTS IN CONNECTION TO THE REFERRAL SERVICES THEREWITH, AND REFERRAL SERVICES FOR LEGAL AND FINANCIAL ISSUES AND WORK AND FAMILY PROBLEMS; COST MANAGEMENT SERVICES FOR HEALTH CARE BENEFIT PLANS OF OTHERS PROVIDED VIA A GLOBAL COMPUTER NETWORK; HEALTH CARE UTILIZATION AND REVIEW SERVICES PROVIDED VIA A GLOBAL COMPUTER NETWORK; INVOICING SERVICES IN THE FIELD OF HEALTH CARE PROVIDED VIA A GLOBAL COMPUTER NETWORK; ORGANIZING AND ADMINISTERING NETWORKS OF HEALTH CARE PROVIDERS AND HEALTH CARE SPECIALISTS; ADMINISTRATION OF PHARMACY REIMBURSEMENT PROGRAMS AND SERVICES; DRUG UTILIZATION REVIEW SERVICES; MEDICAL CASE MANAGEMENT SERVICES, NAMELY, MEDICAL REFERRAL OF INDIVIDUALS TO APPROPRIATE HEALTH MANAGEMENT PROGRAMS; MEDICATION MANAGEMENT SERVICES FOR COST CONTAINMENT PURPOSES, NAMELY, ASSESSING MEDICATION USE HISTORY AND PROVIDING IN-

CLASS 35—(Continued).

FORMATION REGARDING MEDICATION USE, OPTIONS, AND COST MANAGEMENT; BUSINESS MANAGEMENT CONSULTING SERVICES IN THE FIELDS OF HEALTH CARE, HEALTH BENEFITS AND HEALTH CARE SYSTEMS; RETAIL PHARMACY SERVICES PROVIDED VIA A NETWORK OF RETAIL PHARMACIES; EMPLOYEE ASSISTANCE SERVICES, NAMELY, PROVIDING ON-LINE, TELEPHONIC, AND IN-PERSON CONSULTATION, INFORMATION AND ASSESSMENT FOR WORK AND EMPLOYMENT-RELATED PROBLEMS; DISEASE MANAGEMENT SERVICES, NAMELY, REFERRAL OF INDIVIDUALS TO APPROPRIATE HEALTH MANAGEMENT PROGRAMS; MANAGEMENT CONSULTING SERVICES IN THE PLANNING, ORGANIZATION AND IMPLEMENTATION OF HEALTH CARE SERVICES; HEALTH INSURANCE PLAN NETWORK MANAGEMENT SERVICES; ADMINISTRATION OF A DISCOUNT PROGRAM FOR ENABLING PARTICIPANTS TO OBTAIN DISCOUNTS ON GOODS AND SERVICES OF OTHERS IN THE FIELD OF HEALTH AND WELLNESS THROUGH USE OF A MEMBERSHIP CARD; PROVIDING A HEALTH CARE PROVIDER INCENTIVE REWARD PROGRAM FOLLOWING A PAY-FOR-PERFORMANCE SERVICE MODEL, NAMELY, CONDUCTING A HEALTH CARE PROVIDER INCENTIVE REWARD PROGRAM TO PROMOTE IMPROVEMENT IN HEALTH CARE ACCESS AND OUTCOMES FOR ENROLLEES; PHARMACEUTICAL MANUFACTURER CONTRACTING SERVICES IN THE NATURE OF PROCURING OF CONTRACTS FOR THE PURCHASE AND SALE OF GOODS; HEALTH CARE COST MANAGEMENT SERVICES FOR GOVERNMENT SPONSORED HEALTH CARE BENEFIT PROGRAMS; PROVIDING MEDICAL REFERRALS TO ELDERLY AND CHRONICALLY ILL POPULATIONS; PROVIDING REFERRAL SERVICES TO THE ELDERLY IN THE FIELDS OF HEALTH CARE AND WELL-BEING, WELLNESS AND NUTRITION, MEDICAL EQUIPMENT AND MEDICAL SUPPLIES, TRANSPORTATION, HOUSING AND HOME REPAIR, FINANCIAL COUNSELING AND FINANCIAL SERVICES, INSURANCE SERVICES, COMMUNITY SERVICES AND RESOURCES, HOME SECURITY SYSTEMS AND PERSONAL EMERGENCY RESPONSE SYSTEMS, AND LEGAL SERVICES; GIFT REGISTRY SERVICES; ARRANGING AND CONDUCTING INCENTIVE REWARD PROGRAMS TO PROMOTE THE SALE OF HEALTH AND WELLNESS RELATED GOODS AND SERVICES OF OTHERS; ARRANGING AND CONDUCTING INCENTIVE AWARD PROGRAMS TO PROMOTE THE QUALITY AND EFFICIENCY OF HEALTH CARE PROVIDERS; ARRANGING AND CONDUCTING INCENTIVE REWARD PROGRAMS TO ENCOURAGE HEALTHY ACTIVITIES AND HEALTHY BEHAVIOR AMONG ENROLLEES OF HEALTH PLANS; DEVELOPMENT AND ADMINISTRATION OF GROUP PURCHASING PROGRAMS AS A VALUE-ADDED EMPLOYEE BENEFIT, NAMELY, NEGOTIATING CONTRACTS WITH PROVIDERS OF HEALTHCARE-RELATED GOODS AND SERVICES TO ENABLE PARTICIPANT MEMBERS TO OBTAIN DISCOUNTS ON THE PURCHASE OF HEALTHCARE-RELATED GOODS AND SERVICES; MEDICAL AND HEALTH-CARE COST/PRICE ANALYSIS; ADMINISTRATION OF A DISCOUNT PROGRAM FOR ENABLING PARTICIPANTS TO OBTAIN HEALTH AND WELLNESS SERVICES FROM A NETWORK OF HEALTH CARE PROVIDERS; PROVIDING A WEB SITE FEATURING CONSUMER DISCOUNTS ON THE GOODS AND SERVICES OF OTHERS THROUGH USE OF A DISCOUNT MEMBERSHIP PROGRAM; ADMINISTRATION OF A DISCOUNT PROGRAM FOR ENABLING PARTICIPANTS TO OBTAIN DISCOUNTS ON GOODS AND SERVICES OF OTHERS THROUGH USE OF A MEMBERSHIP CARD; COLLECTION OF MEDICAL BUSINESS AND DIRECTORY INFORMATION, NAMELY, COLLECTING INFORMATION FROM HEALTH CARE PROFESSIONALS AND HEALTH CARE PROVIDER ORGANIZATIONS REGARDING THE SPECIALTIES, CREDENTIALS, EFFECTIVENESS, EXPERIENCE, EXPERTISE, EFFICIENCY AND QUALITY OF HEALTH CARE PROFESSIONALS AND HEALTH CARE PROVIDER ORGANIZATIONS, ANALYZING SUCH INFORMATION, DISSEMINATING SUCH INFORMATION TO PROVIDE RECOGNITION TO THE HEALTH CARE PROFESSIONALS AND HEALTH CARE PROVIDER ORGANIZATIONS WHICH MEET CERTAIN CRITERIA, AND PROVIDING SUCH DIRECTORY INFORMATION

CLASS 35—(Continued).

TO HEALTH CARE PROFESSIONALS AND HEALTH CARE PROVIDER ORGANIZATIONS FOR FURTHER USE; PROVIDING A RECOGNITION PROGRAM IN THE NATURE OF INCENTIVE AWARD PROGRAMS TO MEMBER PHYSICIANS AND MEDICAL PROFESSIONALS TO PROMOTE PRODUCTIVITY, QUALITY, AND EFFICIENCY; BUSINESS ASSISTANCE SERVICES, NAMELY, CONDUCTING A PROGRAM BY WHICH INFORMATION REGARDING THE QUALITY, EFFICIENCY AND ADMINISTRATIVE PROCESSES AND OUTCOMES OF VARIOUS PHYSICIANS AND HEALTH CARE PROFESSIONALS IS COLLECTED AND EVALUATED FOR USE IN PROVIDING FEEDBACK ON ADMINISTRATIVE PROCESSES AND OUTCOMES AND FOR RECOGNIZING AND REWARDING QUALITY, EFFICIENCY, AND ADMINISTRATIVE PROCESSES AND OUTCOMES; ADMINISTRATION OF DISCOUNT PROGRAMS FOR ENABLING PARTICIPANTS TO OBTAIN DISCOUNTS ON PHARMACEUTICALS THROUGH USE OF A DISCOUNT MEMBERSHIP CARD; ON-LINE HEALTH INSURANCE AND BENEFITS SERVICES, NAMELY, PROVIDING A DATABASE OF PROVIDERS AND PHYSICIANS FOR REFERRAL PURPOSES; PROVIDING ON-LINE RETAIL PHARMACY SERVICES (U.S. CLS. 100, 101 AND 102).

AMY HELLA, EXAMINING ATTORNEY

SN 85-302,351. GASTROCEUTICALS, LLC, BEVERLY HILLS, CA. FILED 4-22-2011.

OFF CERTIFIERS

THE MARK CONSISTS OF STANDARD CHARACTERS WITHOUT CLAIM TO ANY PARTICULAR FONT, STYLE, SIZE, OR COLOR.

FOR RETAIL STORE, WHOLESALE STORE AND ON-LINE RETAIL STORE AND WHOLESALE STORE AND DISTRIBUTORSHIP SERVICES FEATURING WEIGHT CONTROL INFORMATION AND FOODS, BEVERAGES AND DIETARY SUPPLEMENTS THAT PROMOTE WEIGHT CONTROL, INCLUDING BUT NOT LIMITED TO FOODS AND BEVERAGES, ORGANIC FOODS AND BEVERAGES, NATURAL FOODS AND BEVERAGES, PROCESSED FOODS AND BEVERAGES, NAMELY, FATS, OILS, DAIRY, MILK, YOGURT, CHEESE, MEAT, FISH, POULTRY, VEGETABLES, FRUIT, NUTS, CEREAL, GRAIN, RICE, PASTA, NOODLES, CONFECTIONERY, NAMELY, CANDIES, GUMMIES, CHEWING GUMS, JAMS, JELLIES, NUTRITIONAL BARS, BAKERY ITEMS, NAMELY, PIES, COOKIES, CAKE, ROLLS, BREAD, BUNS, TARTS, DESSERTS, NAMELY, ICE CREAMS AND FROZEN YOGURT, CONDIMENTS, NAMELY, CATSUP, MUSTARD, MAYONNAISE (U.S. CLS. 100, 101 AND 102).

KEVIN DINALLO, EXAMINING ATTORNEY

CLASS 35—(Continued).

SN 85-302,435. GYPSUM MANAGEMENT AND SUPPLY, INC., TUCKER, GA. FILED 4-22-2011.

FLINT RIVER MATERIALS, INC.

THE MARK CONSISTS OF STANDARD CHARACTERS WITHOUT CLAIM TO ANY PARTICULAR FONT, STYLE, SIZE, OR COLOR.

NO CLAIM IS MADE TO THE EXCLUSIVE RIGHT TO USE "MATERIALS, INC.", APART FROM THE MARK AS SHOWN.

SEC. 2(F).

FOR DISTRIBUTORSHIPS IN THE FIELD OF COMMERCIAL BUILDING MATERIALS; WHOLESALE DISTRIBUTORSHIPS IN THE FIELD OF COMMERCIAL BUILDING MATERIALS (U.S. CLS. 100, 101 AND 102).

FIRST USE 5-1-1997; IN COMMERCE 5-1-1997.

LINDSEY RUBIN, EXAMINING ATTORNEY

SN 85-304,121. BAIR, LISA B., GLADSTONE, NJ. FILED 4-25-2011.

HOBART INNOVATIONS

THE MARK CONSISTS OF STANDARD CHARACTERS WITHOUT CLAIM TO ANY PARTICULAR FONT, STYLE, SIZE, OR COLOR.

NO CLAIM IS MADE TO THE EXCLUSIVE RIGHT TO USE "INNOVATIONS", APART FROM THE MARK AS SHOWN.

FOR CONSULTING SERVICES, NAMELY, ADVISING COMPANIES IN THE PHARMACEUTICAL AND BIOTECHNOLOGY FIELDS ABOUT BUSINESS STRATEGIES (U.S. CLS. 100, 101 AND 102).

FIRST USE 11-0-2010; IN COMMERCE 11-0-2010.

SARA BENJAMIN, EXAMINING ATTORNEY

SN 85-304,299. DUMAS HOLDINGS, LLC, MODESTO, CA. FILED 4-25-2011.

SIMPLY BRILLIANT PRESS

THE MARK CONSISTS OF STANDARD CHARACTERS WITHOUT CLAIM TO ANY PARTICULAR FONT, STYLE, SIZE, OR COLOR.

NO CLAIM IS MADE TO THE EXCLUSIVE RIGHT TO USE "PRESS", APART FROM THE MARK AS SHOWN.

FOR CATALOG ORDERING SERVICE FEATURING STATIONERY, BUSINESS FORMS AND BUSINESS CARDS; COPYING OF DOCUMENTS; DIRECT MAIL ADVERTISING SERVICES; DOCUMENT REPRODUCTION; PHOTOCOPYING; PROVIDING FACILITIES FOR THE USE OF OFFICE EQUIPMENT AND MACHINERY (U.S. CLS. 100, 101 AND 102).

DOMINIC J. FERRAIUOLO, EXAMINING ATTORNEY

CLASS 35—(Continued).

SN 85-304,708. BAIR, LISA B., GLADSTONE, NJ. FILED 4-26-2011.



NO CLAIM IS MADE TO THE EXCLUSIVE RIGHT TO USE "GROUP", APART FROM THE MARK AS SHOWN.

THE MARK CONSISTS OF THE WORDS "THE HOBART GROUP" IN BLOCK LETTERS BELOW A DESIGN CONSISTING OF TWO REVERSE CRESCENT MOONS AND FIVE CIRCLES INCREASING AND DECREASING IN SIZE ACROSS THE REVERSE CRESCENT MOONS. THE STIPPLING IS FOR SHADING PURPOSES ONLY.

FOR CONSULTING SERVICES, NAMELY, ADVISING COMPANIES IN THE PHARMACEUTICAL AND BIOTECHNOLOGY FIELDS ABOUT BUSINESS STRATEGIES (U.S. CLS. 100, 101 AND 102).

FIRST USE 5-0-2006; IN COMMERCE 5-0-2006.
SARA BENJAMIN, EXAMINING ATTORNEY

CLASS 35—(Continued).

SN 85-305,251. ZAK, PAUL J., CLAREMONT, CA. FILED 4-26-2011.

Ofactor

THE MARK CONSISTS OF STANDARD CHARACTERS WITHOUT CLAIM TO ANY PARTICULAR FONT, STYLE, SIZE, OR COLOR.

FOR BUSINESS MANAGEMENT CONSULTING SERVICES; CONDUCTING BUSINESS SURVEYS FOR OTHERS FOR PURPOSES OF IMPROVING EMPLOYEE PERFORMANCE AND MORALE; CONDUCTING BUSINESS SURVEYS TO DETERMINE LEVELS OF TRUST IN INDIVIDUALS IN AN ORGANIZATION; BUSINESS AND RESEARCH SURVEY SERVICES, NAMELY, PREPARATION OF BUSINESS SURVEYS TO DETERMINE LEVELS OF TRUST IN INDIVIDUALS IN AN ORGANIZATION; BUSINESS RESEARCH SERVICES USING NON-INVASIVE TESTING FOR THE DETERMINATION OF AN INDICATION OF CHEMICAL NEUROTRANSMITTERS IN INDIVIDUALS GEARED TOWARD INCREASING BUSINESS PRODUCTIVITY (U.S. CLS. 100, 101 AND 102).

BRENDAN MCCAULEY, EXAMINING ATTORNEY

SN 85-304,758. BAIR, LISA B., GLADSTONE, NJ. FILED 4-26-2011.



NO CLAIM IS MADE TO THE EXCLUSIVE RIGHT TO USE "INNOVATIONS", APART FROM THE MARK AS SHOWN.

THE MARK CONSISTS OF THE WORD "HOBART" IN SMALL BLOCK LETTERS ABOVE THE WORD "INNOVATIONS" IN LOWER-CASE LETTERS, WITH THE LETTERS "INNO" IN BUBBLE FONT AND A DESIGN BELOW THE WORDS CONSISTING OF A CURVED BAND WITH THREE BALLS INCREASING IN SIZE AT THE END OF THE CURVE. THE STIPPLING IS FOR SHADING PURPOSES ONLY.

FOR CONSULTING SERVICES, NAMELY, ADVISING COMPANIES IN THE PHARMACEUTICAL AND BIOTECHNOLOGY FIELDS ABOUT BUSINESS STRATEGIES (U.S. CLS. 100, 101 AND 102).

FIRST USE 11-0-2010; IN COMMERCE 11-0-2010.
SARA BENJAMIN, EXAMINING ATTORNEY

SN 85-305,551. ALLYSON AMES COMPANY, INC., CORONA DEL MAR, CA. FILED 4-27-2011.

SWEETACULAR

THE MARK CONSISTS OF STANDARD CHARACTERS WITHOUT CLAIM TO ANY PARTICULAR FONT, STYLE, SIZE, OR COLOR.

FOR ADVERTISING AND BUSINESS SERVICES, NAMELY, RETAIL BAKERY, RETAIL STORE SERVICES FEATURING PARTIES, CLOTHING, TOYS, GAMES, BAKING MERCHANDISE, GIFTWARE, CRAFTS, PET PRODUCTS, MUSIC, AND VIDEO GAMES (U.S. CLS. 100, 101 AND 102).

FIRST USE 1-1-2005; IN COMMERCE 1-1-2011.

JANICE L. MCMORROW, EXAMINING ATTORNEY

CLASS 35—(Continued).

SN 85-305,553. ALLYSON AMES COMPANY, INC., CORONA DEL MAR, CA. FILED 4-27-2011.

WONDERIFIC

THE MARK CONSISTS OF STANDARD CHARACTERS WITHOUT CLAIM TO ANY PARTICULAR FONT, STYLE, SIZE, OR COLOR.

FOR ADVERTISING AND BUSINESS SERVICES, NAMELY, RETAIL BAKERY, RETAIL STORE SERVICES FEATURING PARTIES, CLOTHING, TOYS, GAMES, BAKING MERCHANDISE, GIFTWARE, CRAFTS, PET PRODUCTS, MUSIC, AND VIDEO GAMES (U.S. CLS. 100, 101 AND 102).

FIRST USE 1-1-2005; IN COMMERCE 1-1-2011.

JANICE L. MCMORROW, EXAMINING ATTORNEY

SN 85-306,015. MICHALAK, SLAWOMIR, ROHNERT PARK, CA. FILED 4-27-2011.

HYDRO DEPOT

THE MARK CONSISTS OF STANDARD CHARACTERS WITHOUT CLAIM TO ANY PARTICULAR FONT, STYLE, SIZE, OR COLOR.

NO CLAIM IS MADE TO THE EXCLUSIVE RIGHT TO USE "DEPOT", APART FROM THE MARK AS SHOWN.

SEC. 2(F).

FOR WHOLESALE AND RETAIL STORE SERVICES AND ON-LINE RETAIL AND WHOLESALE STORE SERVICES FEATURING HORTICULTURAL SUPPLIES (U.S. CLS. 100, 101 AND 102).

FIRST USE 12-31-1997; IN COMMERCE 12-31-2001.

REBECCA EISINGER, EXAMINING ATTORNEY

SN 85-306,159. MARTHA A O'MARA, CAMBRIDGE, MA. FILED 4-27-2011.

Place Strategy

THE MARK CONSISTS OF STANDARD CHARACTERS WITHOUT CLAIM TO ANY PARTICULAR FONT, STYLE, SIZE, OR COLOR.

NO CLAIM IS MADE TO THE EXCLUSIVE RIGHT TO USE "STRATEGY", APART FROM THE MARK AS SHOWN.

SEC. 2(F).

FOR BUSINESS STRATEGY DEVELOPMENT SERVICES, NAMELY, DEVELOPING STRATEGIES FOR BUSINESSES RELATING TO DETERMINING THE BEST PHYSICAL LOCATIONS FOR THEIR BUSINESSES, FOR THE PURPOSE OF CREATING AND SUSTAINING COMPETITIVE ADVANTAGE (U.S. CLS. 100, 101 AND 102).

FIRST USE 6-4-2003; IN COMMERCE 6-4-2003.

EVELYN BRADLEY, EXAMINING ATTORNEY

CLASS 35—(Continued).

SN 85-307,958. INFORMED FAMILIES, MIAMI, FL. FILED 4-29-2011.



NO CLAIM IS MADE TO THE EXCLUSIVE RIGHT TO USE "FAMILIES PROGRAMS", APART FROM THE MARK AS SHOWN.

THE MARK CONSISTS OF THE WORDS "SAFE HOMES" WITH THE "S" AND "H" CAPITALIZED AND THE OTHER LETTERS IN UNDERCASE, IN A SANS SERIF FONT WITH THIN LETTERS, ABOVE THE WORDS "SAFE PARTIES" WITH THE "S" AND "P" CAPITALIZED AND THE OTHER LETTERS IN UNDERCASE, IN A SANS SERIF FONT WITH THICK BLOCK LETTERS, WITH THE TOPS OF THE LETTERS "S" AND "F" IN "SAFE" BEING ELONGATED TO MAKE A SORT OF UNDERLINE TO THE WORDS ABOVE, AND A SIMILAR LINE FROM THE DOT OF THE "I" IN "PARTIES" ELONGATED TO UNDERLINE THE WORDS ABOVE, AND A DEPICTION OF A HOUSE TO THE RIGHT OF THE WORD "HOMES" AND OVER THE LETTERS "E" AND "S" IN "PARTIES", WITH A DEPICTION OF THE SUN RISING OVER THE UPPER RIGHT CORNER OF THE HOUSE, AND THE WORDS "AN INFORMED FAMILIES PROGRAM" IN ALL CAPS ALL ALONG THE BOTTOM OF THE MARK AND THE WORDS "SAFE PARTIES".

FOR PROMOTING PUBLIC AWARENESS OF THE NEED FOR DRUG ABUSE PREVENTION (U.S. CLS. 100, 101 AND 102).

FIRST USE 12-31-1994; IN COMMERCE 12-31-1994.

CHRISTINA SOBRAL, EXAMINING ATTORNEY

SN 85-308,236. LIFTLUXE LLC, NEW YORK, NY. FILED 4-29-2011.

LIFTLUXE

THE MARK CONSISTS OF STANDARD CHARACTERS WITHOUT CLAIM TO ANY PARTICULAR FONT, STYLE, SIZE, OR COLOR.

FOR WEBSITE RETAIL STORE SERVICES FOR MEN FEATURING LUXURY AND FASHION CLOTHING, APPAREL, SHOES, BELTS, AND FASHION ACCESSORIES; PROVIDING A WEBSITE FEATURING COMMERCIAL INFORMATION AND REFERRALS IN THE FIELD OF SHOPPING FOR LUXURY AND FASHION CLOTHING, APPAREL, AND FASHION ACCESSORIES; DATA COMPILING AND ANALYZING IN THE FIELD OF LUXURY AND FASHION CLOTHING, APPAREL, SHOES, BELTS, AND FASHION ACCESSORIES (U.S. CLS. 100, 101 AND 102).

YAT SYE, LEE, EXAMINING ATTORNEY

CLASS 35—(Continued).

SN 85-309,671. URGENT CARE COLLEGE OF PHYSICIANS, WARRENVILLE, IL. FILED 5-2-2011.

UCCOP

THE MARK CONSISTS OF STANDARD CHARACTERS WITHOUT CLAIM TO ANY PARTICULAR FONT, STYLE, SIZE, OR COLOR.

FOR ASSOCIATION SERVICES, NAMELY, PROMOTING QUALITY, VALUE AND ADVANCEMENT IN THE CLINICAL PRACTICE OF URGENT CARE MEDICINE (U.S. CLS. 100, 101 AND 102).

FIRST USE 4-25-2011; IN COMMERCE 4-25-2011.
ERNEST SHOSHO, EXAMINING ATTORNEY

SN 85-309,673. URGENT CARE COLLEGE OF PHYSICIANS, WARRENVILLE, IL. FILED 5-2-2011.



NO CLAIM IS MADE TO THE EXCLUSIVE RIGHT TO USE "URGENT CARE", "COLLEGE OF PHYSICIANS", AND "THE PICTORIAL REPRESENTATION OF THE CADUCEUS SYMBOL", APART FROM THE MARK AS SHOWN.

THE MARK CONSISTS OF A CIRCLE ENCLOSEING THE IMAGE OF THE CADUCEUS SYMBOL, ABOVE WHICH THE TERM "UCCOP" APPEARS. AROUND THE BORDER OF THE CIRCLE ARE THE TERMS "URGENT CARE COLLEGE OF PHYSICIANS" FLANKED BY TWO STARS.

FOR ASSOCIATION SERVICES, NAMELY, PROMOTING QUALITY, VALUE AND ADVANCEMENT IN THE CLINICAL PRACTICE OF URGENT CARE MEDICINE (U.S. CLS. 100, 101 AND 102).

FIRST USE 4-25-2011; IN COMMERCE 4-25-2011.
ERNEST SHOSHO, EXAMINING ATTORNEY

CLASS 35—(Continued).

SN 85-311,206. AMERICAN SPORTS LICENSING, INC., WILMINGTON, DE. FILED 5-3-2011.

DICK'S SPORTING GOODS

THE MARK CONSISTS OF STANDARD CHARACTERS WITHOUT CLAIM TO ANY PARTICULAR FONT, STYLE, SIZE, OR COLOR.

OWNER OF U.S. REG. NOS. 2,621,711, 3,239,877 AND OTHERS.

NO CLAIM IS MADE TO THE EXCLUSIVE RIGHT TO USE "SPORTING GOODS", APART FROM THE MARK AS SHOWN.

FOR RETAIL STORE SERVICES FEATURING SPORTING GOODS AND EQUIPMENT, FITNESS EQUIPMENT, APPAREL AND FOOTWEAR; ONLINE RETAIL STORE SERVICES FEATURING SPORTING GOODS AND EQUIPMENT, FITNESS EQUIPMENT, APPAREL AND FOOTWEAR (U.S. CLS. 100, 101 AND 102).

FIRST USE 10-1-1996; IN COMMERCE 10-1-1996.
CAROLINE WOOD, EXAMINING ATTORNEY

SN 85-311,577. MEYER, CONSTANCE, DBA PERFORMANCE PARTNERS, TAKOMA PARK, MD. FILED 5-3-2011.

Strategic Start

THE MARK CONSISTS OF STANDARD CHARACTERS WITHOUT CLAIM TO ANY PARTICULAR FONT, STYLE, SIZE, OR COLOR.

OWNER OF U.S. REG. NO. 2,881,963.

NO CLAIM IS MADE TO THE EXCLUSIVE RIGHT TO USE "STRATEGIC", APART FROM THE MARK AS SHOWN.

FOR BUSINESS CONSULTING SERVICES IN THE FIELD OF ORGANIZATIONAL CHANGE MANAGEMENT; BUSINESS MANAGEMENT AND CONSULTATION IN THE FIELD OF EXECUTIVE TRANSITIONS; BUSINESS MANAGEMENT CONSULTATION IN THE FIELD OF EXECUTIVE AND LEADERSHIP DEVELOPMENT (U.S. CLS. 100, 101 AND 102).

FIRST USE 4-10-1999, THE MARK WAS FIRST USED ANYWHERE IN A DIFFERENT FORM OTHER THAN THAT SOUGHT TO BE REGISTERED AT LEAST AS EARLY AS 04/10/1999; IN COMMERCE 4-10-1999, THE MARK WAS FIRST USED IN COMMERCE IN A DIFFERENT FORM OTHER THAN THAT SOUGHT TO BE REGISTERED AT LEAST AS EARLY AS 04/10/1999.

KAELIE KUNG, EXAMINING ATTORNEY

CLASS 35—(Continued).

SN 85-311,596. DANIELLE BOYCE, DBA YES! I CAN FITNESS, MAGNOLIA, TX. FILED 5-3-2011.

Yes! I Can Fitness

THE MARK CONSISTS OF STANDARD CHARACTERS WITHOUT CLAIM TO ANY PARTICULAR FONT, STYLE, SIZE, OR COLOR.

NO CLAIM IS MADE TO THE EXCLUSIVE RIGHT TO USE "FITNESS", APART FROM THE MARK AS SHOWN. FOR ONLINE ADVERTISING AND PROMOTIONAL SERVICES (U.S. CLS. 100, 101 AND 102).

FIRST USE 1-1-2008; IN COMMERCE 1-1-2008. JESSICA A. POWERS, EXAMINING ATTORNEY

SN 85-311,649. ALLYSON AMES COMPANY, INC., CORONA DEL MAR, CA. FILED 5-4-2011.

WONDERLICIOUS

THE MARK CONSISTS OF STANDARD CHARACTERS WITHOUT CLAIM TO ANY PARTICULAR FONT, STYLE, SIZE, OR COLOR.

OWNER OF U.S. REG. NO. 3,629,516. FOR ADVERTISING AND BUSINESS SERVICES, NAMELY, RETAIL BAKERY, RETAIL STORE SERVICES FEATURING PARTIES, CLOTHING, TOYS, GAMES, BAKING MERCHANDISE, GIFTWARE, CRAFTS, PET PRODUCTS, MUSIC, AND VIDEO GAMES (U.S. CLS. 100, 101 AND 102).

FIRST USE 1-1-2005; IN COMMERCE 1-1-2011. JANICE L. MCMORROW, EXAMINING ATTORNEY

SN 85-312,163. PAWAR, RANJEET, DBA ARTFULLY ELEGANT, BETHLEHEM, PA. FILED 5-4-2011.

ARTFULLY *elegant*

FOR ONLINE RETAIL JEWELRY STORES (U.S. CLS. 100, 101 AND 102).

FIRST USE 1-1-2009; IN COMMERCE 4-1-2009. JACLYN KIDWELL WALKER, EXAMINING ATTORNEY

CLASS 35—(Continued).

SN 85-313,028. KELLEY, JULIE, NEW YORK, NY. FILED 5-5-2011.

ORGANSMIC

THE MARK CONSISTS OF STANDARD CHARACTERS WITHOUT CLAIM TO ANY PARTICULAR FONT, STYLE, SIZE, OR COLOR.

FOR WHOLESALE GROCERY DISTRIBUTORSHIP SERVICES FOR ORGANIC PRODUCTS, NAMELY, FOODS, HERBAL REMEDIES AND BEAUTY PRODUCTS (U.S. CLS. 100, 101 AND 102).

FIRST USE 1-1-2010; IN COMMERCE 1-1-2010. LINDSEY RUBIN, EXAMINING ATTORNEY

SN 85-313,932. PARI MILLER, SANTA MARIA, CA. FILED 5-6-2011.

BARGAINS GALORE BAZAAR

THE MARK CONSISTS OF STANDARD CHARACTERS WITHOUT CLAIM TO ANY PARTICULAR FONT, STYLE, SIZE, OR COLOR.

NO CLAIM IS MADE TO THE EXCLUSIVE RIGHT TO USE "BARGAINS" AND "BAZAAR", APART FROM THE MARK AS SHOWN.

FOR RETAIL STORE SERVICES AND ON-LINE RETAIL STORE SERVICES FEATURING NEW AND USED GENERAL CONSUMER MERCHANDISE (U.S. CLS. 100, 101 AND 102).

WENDY JUN, EXAMINING ATTORNEY

SN 85-315,478. AFFILIATED FOODS MIDWEST COOPERATIVE, INC., NORFOLK, NE. FILED 5-9-2011.

COOPERATIVE MEDIA SOLUTIONS

THE MARK CONSISTS OF STANDARD CHARACTERS WITHOUT CLAIM TO ANY PARTICULAR FONT, STYLE, SIZE, OR COLOR.

FOR ADVERTISING, MARKETING, PROMOTION AND SOCIAL MEDIA STRATEGY SERVICES; ADVERTISING, MARKETING, AND PROMOTION OF SALES COOPERATIVES, AND WHOLESALERS AND DISTRIBUTORS OF GOODS, VIA THE INTERNET, SOCIAL MEDIA, AND PRINT ADVERTISING (U.S. CLS. 100, 101 AND 102).

TOBY BULLOFF, EXAMINING ATTORNEY

CLASS 35—(Continued).

SN 85-315,898. SOHO PRODUCTS, INC., DBA SOHO PAPER, LIVINGSTON, NJ. FILED 5-9-2011.

CLASS 35—(Continued).

SN 85-322,860. TALENTSOUP, LLC, SAVANNAH, GA. FILED S.R. 5-17-2011; AM. P.R. 2-18-2012.

SOHO PAPER

THE MARK CONSISTS OF STANDARD CHARACTERS WITHOUT CLAIM TO ANY PARTICULAR FONT, STYLE, SIZE, OR COLOR.

NO CLAIM IS MADE TO THE EXCLUSIVE RIGHT TO USE "PAPER", APART FROM THE MARK AS SHOWN.

FOR WHOLESALE DISTRIBUTORSHIP SERVICES FEATURING PRINTED PAPER PRODUCTS (U.S. CLS. 100, 101 AND 102).

FIRST USE 1-6-1998; IN COMMERCE 1-6-1998.
LINDA POWELL, EXAMINING ATTORNEY

Webcomp

SN 85-319,190. ALLEGIANCE RETAIL SERVICES, LLC, ISELIN, NJ. FILED 5-12-2011.



NO CLAIM IS MADE TO THE EXCLUSIVE RIGHT TO USE "MARKET FRESH", APART FROM THE MARK AS SHOWN.

THE COLOR(S) LIGHT GREEN AND DARK GREEN IS/ARE CLAIMED AS A FEATURE OF THE MARK.

THE MARK CONSISTS OF THE WORDS "MARKET FRESH" IN DARK GREEN, WITH TWO LIGHT GREEN LEAVES OVER THE "H", CONTAINED WITHIN A LIGHT GREEN DASHED RECTANGULAR BOX WHICH ITSELF IS CONTAINED WITH A SOLID LIGHT GREEN RECTANGULAR BOX.

FOR RETAIL FOOD SUPERMARKET SERVICES (U.S. CLS. 100, 101 AND 102).

GINA FINK, EXAMINING ATTORNEY

THE MARK CONSISTS OF STANDARD CHARACTERS WITHOUT CLAIM TO ANY PARTICULAR FONT, STYLE, SIZE, OR COLOR.

FOR ADVERTISING AND MARKETING SERVICES, NAMELY, PROMOTING THE GOODS AND SERVICES OF OTHERS; ADVERTISING AND PROMOTING THE GOODS AND SERVICES OF A VISUAL ARTIST; ADVERTISING AND PROMOTION SERVICES AND RELATED CONSULTING; ADVERTISING SERVICES, NAMELY, PROMOTING AND MARKETING THE GOODS AND SERVICES OF OTHERS THROUGH ALL PUBLIC COMMUNICATION MEANS; ENTERTAINMENT MARKETING SERVICES, NAMELY, MARKETING, PROMOTION AND ADVERTISING FOR RECORDING AND PERFORMING ARTISTS; MODELING FOR ADVERTISING OR SALES PROMOTION; MODELING SERVICES FOR ADVERTISING OR SALES PROMOTION; PROMOTING THE GOODS AND SERVICES OF OTHERS BY PROVIDING A WEB SITE AT WHICH USERS CAN LINK TO TALENT'S PORTFOLIO OF PHOTOS, VIDEO, RESUME; PUBLICITY AND SALES PROMOTION SERVICES; TALENT AGENCIES (U.S. CLS. 100, 101 AND 102).

FIRST USE 5-14-2011; IN COMMERCE 5-14-2011.

CIMMERIAN COLEMAN, EXAMINING ATTORNEY

CLASS 35—(Continued).

SN 85-323,430. STRONGER TODAY BRAND, LLC, BOSTON, MA. FILED 5-17-2011.

Stronger Today

THE MARK CONSISTS OF STANDARD CHARACTERS WITHOUT CLAIM TO ANY PARTICULAR FONT, STYLE, SIZE, OR COLOR.

OWNER OF U.S. REG. NOS. 3,661,593, 3,917,789 AND 3,917,844.

FOR ONLINE RETAIL STORE SERVICES FEATURING APPAREL, CLOTHING, HATS, HEADWEAR, UNDERWEAR, BELTS, FOOTWEAR, WATCHES, WRIST BANDS, WALLETS, KEY CHAINS, BACKPACKS, MESSENGER BAGS, DUFFEL BAGS, TOTE BAGS, TRAVEL BAGS, WHEELED BAGS, WAIST PACKS, SLING BAGS, SPORTING GOODS, SPORTS BOTTLES SOLD EMPTY, WATER BOTTLES, SWEAT BANDS, GLOVES, TOWELS, EYEWEAR, SUNGLASSES, BADGES, EVENT TICKETS, MUSIC, PRINTED MATTER, STICKERS, WALLPAPERS, FLASH MEMORY DEVICES, AND ACCESSORIES; RETAIL STORE SERVICES FEATURING APPAREL, CLOTHING, HATS, HEADWEAR, UNDERWEAR, BELTS, FOOTWEAR, WATCHES, WRIST BANDS, WALLETS, KEY CHAINS, BACKPACKS, MESSENGER BAGS, DUFFEL BAGS, TOTE BAGS, TRAVEL BAGS, WHEELED BAGS, WAIST PACKS, SLING BAGS, SPORTING GOODS, SPORTS BOTTLES SOLD EMPTY, WATER BOTTLES, SWEAT BANDS, GLOVES, TOWELS, EYEWEAR, SUNGLASSES, BADGES, EVENT TICKETS, MUSIC, PRINTED MATTER, STICKERS, WALLPAPERS, FLASH MEMORY DEVICES, AND ACCESSORIES; MOBILE RETAIL STORE SERVICES FEATURING APPAREL, CLOTHING, HATS, HEADWEAR, UNDERWEAR, BELTS, FOOTWEAR, WATCHES, WRIST BANDS, WALLETS, KEY CHAINS, BACKPACKS, MESSENGER BAGS, DUFFEL BAGS, TOTE BAGS, TRAVEL BAGS, WHEELED BAGS, WAIST PACKS, SLING BAGS, SPORTING GOODS, SPORTS BOTTLES SOLD EMPTY, WATER BOTTLES, SWEAT BANDS, GLOVES, TOWELS, EYEWEAR, SUNGLASSES, BADGES, EVENT TICKETS, MUSIC, PRINTED MATTER, STICKERS, WALLPAPERS, FLASH MEMORY DEVICES, AND ACCESSORIES (U.S. CLS. 100, 101 AND 102).

CAROLINE WOOD, EXAMINING ATTORNEY

SN 85-325,861. JULIET MURPHY, DBA WOW I LOVE MY CAREER, TUSTIN, CA. FILED 5-20-2011.

WOW I LOVE MY CAREER

THE MARK CONSISTS OF STANDARD CHARACTERS WITHOUT CLAIM TO ANY PARTICULAR FONT, STYLE, SIZE, OR COLOR.

NO CLAIM IS MADE TO THE EXCLUSIVE RIGHT TO USE "CAREER", APART FROM THE MARK AS SHOWN.

FOR CAREER COUNSELING, NAMELY, PROVIDING CAREER INFORMATION (U.S. CLS. 100, 101 AND 102). FIRST USE 7-30-2010; IN COMMERCE 7-21-2011. CURTIS FRENCH, EXAMINING ATTORNEY

CLASS 35—(Continued).

SN 85-328,122. FLYWHEEL SPORTS, INC., NEW YORK, NY. FILED 5-23-2011.

GUYBARRE

THE MARK CONSISTS OF STANDARD CHARACTERS WITHOUT CLAIM TO ANY PARTICULAR FONT, STYLE, SIZE, OR COLOR.

THE NAME(S), PORTRAIT(S), AND/OR SIGNATURE(S) SHOWN IN THE MARK DOES NOT IDENTIFY A PARTICULAR LIVING INDIVIDUAL.

FOR RETAIL STORES FEATURING FITNESS APPAREL (U.S. CLS. 100, 101 AND 102).

TINA L. SNAPP, EXAMINING ATTORNEY

SN 85-329,473. GYPSUM MANAGEMENT AND SUPPLY, INC., TUCKER, GA. FILED 5-25-2011.

GMS
GYPSUM MANAGEMENT & SUPPLY, INC.

NO CLAIM IS MADE TO THE EXCLUSIVE RIGHT TO USE "GYPSUM MANAGEMENT & SUPPLY, INC.", APART FROM THE MARK AS SHOWN.

THE MARK CONSISTS OF THE LETTERS "GMS" IN STYLIZED FONT ABOVE THE WORDS "GYPSUM MANAGEMENT & SUPPLY, INC." IN SMALLER STYLIZED FONT.

FOR DISTRIBUTORSHIPS IN THE FIELD OF COMMERCIAL BUILDING MATERIALS; WHOLESALE DISTRIBUTORSHIPS IN THE FIELD OF COMMERCIAL BUILDING MATERIALS (U.S. CLS. 100, 101 AND 102).

FIRST USE 1-18-1994; IN COMMERCE 1-18-1994.

LINDSEY RUBIN, EXAMINING ATTORNEY

CLASS 35—(Continued).

SN 85-329,474. GYPSUM MANAGEMENT AND SUPPLY, INC., TUCKER, GA. FILED 5-25-2011.



NO CLAIM IS MADE TO THE EXCLUSIVE RIGHT TO USE "GYPSUM" AND "INC.", APART FROM THE MARK AS SHOWN.

THE MARK CONSISTS OF THE WORD "GATOR" IN STYLIZED FONT DIRECTLY BELOW A STYLIZED DRAWING OF AN ALLIGATOR IN GRASS INSIDE OF AN OVAL SHAPE. THE WORDING "GATOR" IS ABOVE THE WORD "GYPSUM". THE ENTIRE DESIGN AND WORDING IS ON TOP OF A BASE THAT COMES TO A POINT AT THE CENTER OF THE WORD "GYPSUM", AND THERE IS A SMALLER FIVE-SIDED SHAPE WITH A POINT IN THE SAME PLACE AS THE BASE WITH THE ACRONYM "INC." INSIDE OF IT.

FOR DISTRIBUTORSHIPS IN THE FIELD OF COMMERCIAL BUILDING MATERIALS; WHOLESALE DISTRIBUTORSHIPS IN THE FIELD OF COMMERCIAL BUILDING MATERIALS (U.S. CLS. 100, 101 AND 102).

FIRST USE 5-25-1984; IN COMMERCE 5-25-1984.
LINDSEY RUBIN, EXAMINING ATTORNEY

SN 85-329,476. GYPSUM MANAGEMENT AND SUPPLY, INC., TUCKER, GA. FILED 5-25-2011.



NO CLAIM IS MADE TO THE EXCLUSIVE RIGHT TO USE "MATERIALS, INC.", APART FROM THE MARK AS SHOWN.

THE MARK CONSISTS OF THE LETTERS "RT" IN STYLIZED LARGE LETTERS ADJACENT AND TO THE LEFT OF THE WORDS "ROCKY TOP MATERIALS, INC." SEC. 2(F) AS TO "ROCKYTOP MATERIALS, INC."

FOR DISTRIBUTORSHIPS IN THE FIELD OF COMMERCIAL BUILDING MATERIALS; WHOLESALE DISTRIBUTORSHIPS IN THE FIELD OF COMMERCIAL BUILDING MATERIALS (U.S. CLS. 100, 101 AND 102).

FIRST USE 1-14-1980; IN COMMERCE 1-14-1980.
LINDSEY RUBIN, EXAMINING ATTORNEY

CLASS 35—(Continued).

SN 85-330,282. R.K./FL MANAGEMENT, INC., SUNNY ISLES BEACH, FL. FILED 5-26-2011.



THE MARK CONSISTS OF THE LETTERS "RK" IN A CIRCLE APPEARING TO THE LEFT OF AN IMAGE OF A BASKETBALL HOOP AND A BASKETBALL WITH THE LETTERS "RK" APPEARING ON THE BASKETBALL.

FOR RETAIL SHOPPING CENTER STORES FEATURING A VARIETY OF GENERAL CONSUMER MERCHANDISE (U.S. CLS. 100, 101 AND 102).

FIRST USE 12-31-1996; IN COMMERCE 12-31-1996.
NORA BUCHANAN WILL, EXAMINING ATTORNEY

SN 85-331,224. BC VENTURES, LLC, DBA MYYYY YO-GURT, RENO, NV. FILED 5-26-2011.

YoMobile

THE MARK CONSISTS OF STANDARD CHARACTERS WITHOUT CLAIM TO ANY PARTICULAR FONT, STYLE, SIZE, OR COLOR.

FOR MOBILE STREET VENDOR SERVICES VIA TRUCK FEATURING FROZEN YOGURT (U.S. CLS. 100, 101 AND 102).

FIRST USE 4-23-2011; IN COMMERCE 4-23-2011.
ODESSA BIBBINS, EXAMINING ATTORNEY

CLASS 35—(Continued).

SN 85-332,018. BEAUTIES OF CHARITY INCORPORATED, TRUMBULL, CT. FILED 5-27-2011.



THE COLOR(S) PINK, PURPLE, BLACK AND WHITE IS/ ARE CLAIMED AS A FEATURE OF THE MARK.

THE MARK CONSISTS OF A PINK CIRCLE OUTLINED IN WHITE AND THEN PURPLE. THE PINK CIRCLE HAS A BLACK SILHOUETTE OF A WOMAN WITH A RANDOM PURPLE AND DARKER PINK DESIGN BEHIND THE SILHOUETTE.

FOR ARRANGING AND CONDUCTING TRADE SHOWS IN THE FIELDS OF BEAUTY, HAIRDRESSING, SKIN CARE AND CAREER DEVELOPMENT IN THESE INDUSTRIES; PROVIDING INFORMATION ABOUT CAREER DEVELOPMENT IN THE FIELDS OF BEAUTY, HAIRDRESSING AND SKIN CARE (U.S. CLS. 100, 101 AND 102).

SUNG IN, EXAMINING ATTORNEY

CLASS 35—(Continued).

SN 85-332,918. ROD HELM, LAS VEGAS, NV. FILED 5-27-2011.

Grant Writing USA

THE MARK CONSISTS OF STANDARD CHARACTERS WITHOUT CLAIM TO ANY PARTICULAR FONT, STYLE, SIZE, OR COLOR.

NO CLAIM IS MADE TO THE EXCLUSIVE RIGHT TO USE "GRANT WRITING", APART FROM THE MARK AS SHOWN.

SEC. 2(F).

FOR PROVIDING ADVISORY SERVICES IN THE FIELD OF WRITING, ADMINISTRATION AND MANAGEMENT OF GOVERNMENT AND PRIVATE SECTOR GRANTS TO GRANT PROPOSAL TEAMS, GRANTS ADMINISTRATIVE OFFICES, AND GRANT MAKING ENTITIES (U.S. CLS. 100, 101 AND 102).

FIRST USE 10-2-2002; IN COMMERCE 10-2-2002.

SARA BENJAMIN, EXAMINING ATTORNEY

SN 85-332,423. BARGAIN BEACHWEAR CORPORATION, MYRTLE BEACH, SC. FILED 5-27-2011.

BARGAIN BEACHWEAR

THE MARK CONSISTS OF STANDARD CHARACTERS WITHOUT CLAIM TO ANY PARTICULAR FONT, STYLE, SIZE, OR COLOR.

NO CLAIM IS MADE TO THE EXCLUSIVE RIGHT TO USE "BEACHWEAR", APART FROM THE MARK AS SHOWN.

SEC. 2(F).

FOR RETAIL STORE SERVICES FEATURING CLOTHING, CLOTHING ACCESSORIES, BEACH AND SURF GEAR, SPORTING GOODS, TOYS AND GAMES, HOUSEHOLD GOODS, GIFTS, NOVELTY ITEMS AND SOUVENIRS (U.S. CLS. 100, 101 AND 102).

FIRST USE 1-31-1984; IN COMMERCE 1-31-1984.

SARA BENJAMIN, EXAMINING ATTORNEY

SN 85-332,926. ROD HELM, LAS VEGAS, NV. FILED 5-27-2011.



GRANT WRITING USA

NO CLAIM IS MADE TO THE EXCLUSIVE RIGHT TO USE "GRANT WRITING USA", APART FROM THE MARK AS SHOWN.

FOR PROVIDING ADVISORY SERVICES IN THE FIELD OF WRITING, ADMINISTRATION AND MANAGEMENT OF GOVERNMENT AND PRIVATE SECTOR GRANTS TO GRANT PROPOSAL TEAMS, GRANTS ADMINISTRATIVE OFFICES, AND GRANT MAKING ENTITIES (U.S. CLS. 100, 101 AND 102).

FIRST USE 10-2-2002; IN COMMERCE 10-2-2002.

SARA BENJAMIN, EXAMINING ATTORNEY

CLASS 35—(Continued).

SN 85-332,928. ROD HELM, LAS VEGAS, NV. FILED 5-27-2011.

Grant Management USA

THE MARK CONSISTS OF STANDARD CHARACTERS WITHOUT CLAIM TO ANY PARTICULAR FONT, STYLE, SIZE, OR COLOR.

NO CLAIM IS MADE TO THE EXCLUSIVE RIGHT TO USE "GRANT MANAGEMENT", APART FROM THE MARK AS SHOWN.

SEC. 2(F).

FOR PROVIDING ADVISORY SERVICES IN THE FIELD OF WRITING, ADMINISTRATION AND MANAGEMENT OF GOVERNMENT AND PRIVATE SECTOR GRANTS TO GRANT PROPOSAL TEAMS, GRANTS ADMINISTRATIVE OFFICES, AND GRANT MAKING ENTITIES (U.S. CLS. 100, 101 AND 102).

FIRST USE 10-2-2002; IN COMMERCE 10-2-2002.

SARA BENJAMIN, EXAMINING ATTORNEY

SN 85-332,936. ROD HELM, LAS VEGAS, NV. FILED 5-27-2011.



NO CLAIM IS MADE TO THE EXCLUSIVE RIGHT TO USE "GRANT MANAGEMENT USA", APART FROM THE MARK AS SHOWN.

FOR PROVIDING ADVISORY SERVICES IN THE FIELD OF WRITING, ADMINISTRATION AND MANAGEMENT OF GOVERNMENT AND PRIVATE SECTOR GRANTS TO GRANT PROPOSAL TEAMS, GRANTS ADMINISTRATIVE OFFICES, AND GRANT MAKING ENTITIES (U.S. CLS. 100, 101 AND 102).

FIRST USE 10-2-2002; IN COMMERCE 10-2-2002.

SARA BENJAMIN, EXAMINING ATTORNEY

SN 85-335,004. COMP OPTIONS INSURANCE COMPANY, INC., JACKSONVILLE, FL. FILED 6-1-2011.

CIRCANA

THE MARK CONSISTS OF STANDARD CHARACTERS WITHOUT CLAIM TO ANY PARTICULAR FONT, STYLE, SIZE, OR COLOR.

FOR MAINTAINING A NETWORK OF HEALTH CARE PROVIDERS WHO HAVE AGREED TO COMPLY WITH NETWORK RULES AND PROCEDURES IN PROVIDING MEDICAL CARE FOR INDIVIDUALS, BOTH FOREIGNERS AND UNITED STATES RESIDENTS, WHO PLAN TO TRAVEL OUTSIDE OF THEIR HOME COUNTRY (U.S. CLS. 100, 101 AND 102).

CAROLINE WOOD, EXAMINING ATTORNEY

CLASS 35—(Continued).

SN 85-340,251. ROMERO-DEL VALLE, LUIS R., SAN JUAN, PUERTO RICO, AND PANIAGUA-CAMACHO, ANA R., SAN JUAN, PUERTO RICO, FILED 6-7-2011.



THE COLOR(S) BLACK, YELLOW, RED, BROWN, BLUE, ORANGE AND GREEN IS/ARE CLAIMED AS A FEATURE OF THE MARK.

THE MARK CONSISTS OF THE WORD "SOUNDIVERSAL.COM", THE "S" APPEARS IN CAPITAL LETTER AND THE REST OF THE LETTERS IN SMALL CAPS, ALL OF THEM IN COLOR BLACK. ON THE LEFT SIDE, OVER AND UNDER THE LETTERS "S", "O", "U", "N" APPEARS VARIOUS FLOATING CIRCLES OF DIFFERENT SIZES AND COLORS. THE CIRCLE COLORS ARE AS FOLLOWS: ONE (1) ORANGE, THREE (3) DIFFERENT SHADES OF YELLOW; TWO (2) BLUES, ONE DARK AND ONE LIGHT, ONE (1) RED, ONE (1) BROWN AND ONE (1) GREEN.

FOR MANAGING LICENSED RIGHTS FOR USERS OF THE MUSICAL TRACKS OF OTHERS FOR COMMERCIAL PURPOSES SUCH AS SYNCHRONIZATION AGAINST IMAGES, TELEVISION, FILM, VIDEO, INTERNET, CORPORATE PRESENTATIONS, FOR USE IN BROADCASTING, WEBCASTING, ADVERTISING AND PROMOTIONAL EVENTS, AMONG OTHERS (U.S. CLS. 100, 101 AND 102).

TRICIA SONNEBORN, EXAMINING ATTORNEY

SN 85-342,383. GYPSUM MANAGEMENT AND SUPPLY, INC., TUCKER, GA. FILED 6-9-2011.



NO CLAIM IS MADE TO THE EXCLUSIVE RIGHT TO USE "INTERIOR PRODUCTS" AND THE PICTORIAL REPRESENTATION OF THE STATE OF NEW JERSEY, APART FROM THE MARK AS SHOWN.

THE MARK CONSISTS OF THE WORD "CAPITOL" IN A VERY LARGE FONT ABOVE THE WORDS "INTERIOR PRODUCTS" IN A SMALLER FONT WITH AN OUTLINE OF THE STATE OF NEW JERSEY TO THE LEFT AND AN OUTLINE OF THE LIBERTY BELL TO THE RIGHT OF THE WORDS, WITH THE ENTIRE MARK APPEARING IN AN OVAL SHAPE.

FOR DISTRIBUTORSHIPS IN THE FIELD OF COMMERCIAL BUILDING MATERIALS; WHOLESALE DISTRIBUTORSHIPS IN THE FIELD OF COMMERCIAL BUILDING MATERIALS (U.S. CLS. 100, 101 AND 102).

FIRST USE 2-4-2010; IN COMMERCE 2-4-2010.

LINDSEY RUBIN, EXAMINING ATTORNEY

CLASS 35—(Continued).

SN 85-347,338. PRECOA, LLC, PORTLAND, OR. FILED 6-15-2011.

PRECOA

THE MARK CONSISTS OF STANDARD CHARACTERS WITHOUT CLAIM TO ANY PARTICULAR FONT, STYLE, SIZE, OR COLOR.

THE WORDING "PRECOA" HAS NO MEANING IN A FOREIGN LANGUAGE.

FOR OPERATION OF A TELEPHONE CALL CENTER FOR OTHERS THAT MAKES AND RECEIVES TELEPHONE CALLS TO AND FROM CUSTOMERS WITH QUESTIONS ABOUT FUNERAL PLANNING; APPOINTMENT SCHEDULING AND BUSINESS MEETING PLANNING SERVICES TO DISCUSS FUNERAL PLANNING; REFERRAL SERVICES IN THE FIELD OF FUNERAL PLANNING, NAMELY, REFERRING POTENTIAL CUSTOMERS TO CONTRACTORS, AGENTS AND OFFICES THAT PROVIDE FUNERAL PLANNING SERVICES; BUSINESS MARKETING SERVICES, NAMELY, PROMOTING THE FUNERAL SERVICES OF OTHERS BY PASSING BUSINESS LEADS AND REFERRALS; BUSINESS MARKETING SERVICES, NAMELY, PROVIDING MARKETING STRATEGIES, CONCEPTS AND OPERATIONS REGARDING PRE-PLANNING FUNERALS (U.S. CLS. 100, 101 AND 102).

FIRST USE 5-6-2011; IN COMMERCE 5-6-2011.
ELI HELLMAN, EXAMINING ATTORNEY

CLASS 35—(Continued).

SN 85-357,472. THE FREECYCLE NETWORK, TUCSON, AZ. FILED 6-27-2011.

FREECYCLE.ORG

THE MARK CONSISTS OF STANDARD CHARACTERS WITHOUT CLAIM TO ANY PARTICULAR FONT, STYLE, SIZE, OR COLOR.

FOR PROVIDING A WEBSITE FEATURING ADVERTISEMENTS FOR GIVING AND RECEIVING OF FREE PROPERTY OF OTHERS ON A GLOBAL COMPUTER NETWORK (U.S. CLS. 100, 101 AND 102).

JULIE GUTTADAURO, EXAMINING ATTORNEY

SN 85-358,951. OPERATION ORGANIZATION, INC., LOS ANGELES, CA. FILED 6-29-2011.

OPERATION ORGANIZATION

SN 85-348,733. COMPREHENSIVE NEUROSCIENCE, INC., MIRAMAR, FL. FILED 6-17-2011.



NO CLAIM IS MADE TO THE EXCLUSIVE RIGHT TO USE "COMPREHENSIVE CLINICAL DEVELOPMENT", APART FROM THE MARK AS SHOWN.

THE MARK CONSISTS OF THE WORDS "COMPREHENSIVE" IN LARGER CAPITAL LETTERS WITH THE WORDS "CLINICAL DEVELOPMENT" OFFSET AND BELOW THE WORD "COMPREHENSIVE" AND WHERE THE "O" OF THE WORD "COMPREHENSIVE" IS MADE FROM A GRAPHIC OF A NOVA WITH A WIDER ELLIPTICAL ORBIT TRACED IN APPROXIMATELY AT 220 ARC AROUND THE NOVA.

FOR BUSINESS MANAGEMENT CONSULTING; COST MANAGEMENT FOR THE HEALTH BENEFIT PLANS OF OTHERS; PHARMACEUTICAL COST MANAGEMENT SERVICES AND DRUG UTILIZATION REVIEW SERVICES; PHARMACEUTICAL BENEFIT MANAGEMENT SERVICES (U.S. CLS. 100, 101 AND 102).

FIRST USE 3-30-2011; IN COMMERCE 3-30-2011.
MIDGE BUTLER, EXAMINING ATTORNEY

THE MARK CONSISTS OF STANDARD CHARACTERS WITHOUT CLAIM TO ANY PARTICULAR FONT, STYLE, SIZE, OR COLOR.

OWNER OF U.S. REG. NO. 3,974,904.

NO CLAIM IS MADE TO THE EXCLUSIVE RIGHT TO USE "ORGANIZATION", APART FROM THE MARK AS SHOWN.

FOR PROVIDING INFORMATION IN THE FIELD OF TIME MANAGEMENT FOR BUSINESS PURPOSES; MOVING AND RELOCATION SERVICES, NAMELY, PLANNING AND IMPLEMENTING MOVES OF HOMES AND OFFICES; PROVIDING DOOR-TO-DOOR SHOPPING SERVICES IN THE FIELD OF PERSONAL AND COMMERCIAL GOODS, NAMELY, CONTAINERS, CLOSET ORGANIZING SYSTEMS, SHELVING, DRAWERS, FOLDERS, HANGERS, FILE CABINETS, FURNITURE, AND ORGANIZATIONAL ITEMS AND HOME FURNISHINGS; PROVIDING A WEBSITE FEATURING INFORMATION IN THE FIELD OF BUSINESS CONSULTATION SERVICES AND ORGANIZATIONAL SERVICES FOR BUSINESSES (U.S. CLS. 100, 101 AND 102).

FIRST USE 5-25-2005; IN COMMERCE 6-26-2005.
LAURIE KAUFMAN, EXAMINING ATTORNEY

CLASS 35—(Continued).

SN 85-360,460. LIFTLUXE LLC, NEW YORK, NY. FILED 6-30-2011.

LIFTLUXE Men's Lifestyle Elevated

THE MARK CONSISTS OF STANDARD CHARACTERS WITHOUT CLAIM TO ANY PARTICULAR FONT, STYLE, SIZE, OR COLOR.

NO CLAIM IS MADE TO THE EXCLUSIVE RIGHT TO USE "MEN'S LIFESTYLE", APART FROM THE MARK AS SHOWN.

FOR WEBSITE RETAIL STORE SERVICES FOR MEN FEATURING LUXURY AND FASHION CLOTHING, APPAREL, SHOES, BELTS, AND FASHION ACCESSORIES; PROVIDING A WEBSITE FEATURING COMMERCIAL INFORMATION AND REFERRALS IN THE FIELD OF SHOPPING FOR LUXURY AND FASHION CLOTHING, APPAREL, AND FASHION ACCESSORIES; DATA COMPILING AND ANALYZING IN THE FIELD OF LUXURY AND FASHION CLOTHING, APPAREL, SHOES, BELTS, AND FASHION ACCESSORIES (U.S. CLS. 100, 101 AND 102).

YAT SYE, LEE, EXAMINING ATTORNEY

SN 85-361,811. FLYNN & FRIENDS, INC., BUFFALO, NY. FILED 7-1-2011.

ChunkMail

THE MARK CONSISTS OF STANDARD CHARACTERS WITHOUT CLAIM TO ANY PARTICULAR FONT, STYLE, SIZE, OR COLOR.

FOR DIRECT MAIL ADVERTISING SERVICES IN THE NATURE OF DEVELOPING DIRECT MAIL PACKAGES AND PREPARING AND DISTRIBUTING DIRECT MAIL PACKAGES FOR OTHERS (U.S. CLS. 100, 101 AND 102).

FIRST USE 9-1-1998; IN COMMERCE 2-1-1999.

JOHN WILKE, EXAMINING ATTORNEY

SN 85-366,127. SUNEBLT BUSINESS BROKERS OF LAS VEGAS, INC., LAS VEGAS, NV. FILED 7-8-2011.

BUILD IT TO SELL: STAGING YOUR BUSINESS TO ATTAIN THE MAXIMUM VALUE AND PRICE

THE MARK CONSISTS OF STANDARD CHARACTERS WITHOUT CLAIM TO ANY PARTICULAR FONT, STYLE, SIZE, OR COLOR.

FOR BUSINESS MANAGEMENT AND ORGANIZATION CONSULTANCY AND PLANNING (U.S. CLS. 100, 101 AND 102).

FIRST USE 6-1-2011; IN COMMERCE 7-1-2011.

GEOFFREY FOSDICK, EXAMINING ATTORNEY

CLASS 35—(Continued).

SN 85-366,129. SUNEBLT BUSINESS BROKERS OF LAS VEGAS, INC., LAS VEGAS, NV. FILED 7-8-2011.

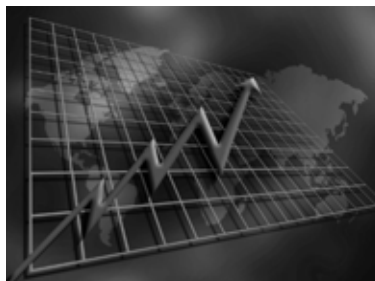

THE MARK CONSISTS OF GRAPH SHOWING INCREASING TREND OF INDEX AND HAVING THE WORLD MAP IN THE BACKGROUND AS SHOWN IN THE MARK.

FOR BUSINESS MANAGEMENT AND ORGANIZATION CONSULTANCY AND PLANNING (U.S. CLS. 100, 101 AND 102).

FIRST USE 6-1-2011; IN COMMERCE 7-1-2011.

GEOFFREY FOSDICK, EXAMINING ATTORNEY

SN 85-367,777. AMERICA APPROVED COMMERCIAL LLC, DBA AMERICA APPROVED ENERGY SERVICES, FT MYERS, FL. FILED 7-11-2011.



NO CLAIM IS MADE TO THE EXCLUSIVE RIGHT TO USE "AMERICA" AND "ENERGY SERVICES DEMAND LOAD CONSUMPTION LED SUPPLY KWH", APART FROM THE MARK AS SHOWN.

THE COLOR(S) RED, BLUE AND WHITE IS/ARE CLAIMED AS A FEATURE OF THE MARK.

THE MARK CONSISTS OF THE WORDING "AMERICAN APPROVED ENERGY SERVICES DEMAND/LOAD SUPPLY/KWH CONSUMPTION/LED" IN BLUE WITH A DESIGN OF A RED, WHITE AND BLUE FLAG AND THREE BLUE ARROWS FORMING A TRIANGLE. THE COLOR WHITE APPEARS IN THE BACKGROUND.

FOR BUSINESS CONSULTING AND ADVISORY SERVICES IN THE FIELD OF ENERGY EFFICIENCY (U.S. CLS. 100, 101 AND 102).

FIRST USE 6-28-2011; IN COMMERCE 7-7-2011.

ROBERT STRUCK, EXAMINING ATTORNEY

CLASS 35—(Continued).

SN 85-367,800. THERASTAFF LLC, SAN DIEGO, CA. FILED 7-11-2011.

TheraStaff

THE MARK CONSISTS OF STANDARD CHARACTERS WITHOUT CLAIM TO ANY PARTICULAR FONT, STYLE, SIZE, OR COLOR.

FOR EMPLOYMENT AGENCY SERVICES, NAMELY, TEMPORARY AND PERMANENT PLACEMENT OF HEALTH CARE PROFESSIONALS (U.S. CLS. 100, 101 AND 102).

FIRST USE 1-1-1995; IN COMMERCE 1-1-1995.
AMY KERTGATE, EXAMINING ATTORNEY

SN 85-368,453. K. ROSS MAY, CANTON, OH. FILED 7-11-2011.

THE YOUNG AMERICAN

THE MARK CONSISTS OF STANDARD CHARACTERS WITHOUT CLAIM TO ANY PARTICULAR FONT, STYLE, SIZE, OR COLOR.

FOR ADVERTISEMENT FOR OTHERS ON THE INTERNET; ADVERTISING AGENCIES; ADVERTISING AGENCIES, NAMELY, PROMOTING THE GOODS AND SERVICES OF OTHERS; ADVERTISING AND BUSINESS MANAGEMENT CONSULTANCY; ADVERTISING AND COMMERCIAL INFORMATION SERVICES, VIA THE INTERNET; ADVERTISING AND DIRECTORY SERVICES, NAMELY, PROMOTING THE SERVICES OF OTHERS BY PROVIDING A WEB PAGE FEATURING LINKS TO THE WEBSITES OF OTHERS; ADVERTISING AND MARKETING; ADVERTISING AND MARKETING CONSULTANCY; ADVERTISING AND MARKETING SERVICES PROVIDED BY MEANS OF INDIRECT METHODS OF MARKETING COMMUNICATIONS, NAMELY, SOCIAL MEDIA, SEARCH ENGINE MARKETING, INQUIRY MARKETING, INTERNET MARKETING, MOBILE MARKETING, BLOGGING AND OTHER FORMS OF PASSIVE, SHARABLE OR VIRAL COMMUNICATIONS CHANNELS; ADVERTISING AND MARKETING SERVICES, NAMELY, PROMOTING THE GOODS AND SERVICES OF OTHERS; ADVERTISING AND PROMOTION SERVICES AND RELATED CONSULTING; ADVERTISING AND PROMOTIONAL SERVICES; ADVERTISING AND PUBLICITY SERVICES; ADVERTISING AND PUBLICITY SERVICES, NAMELY, PROMOTING THE GOODS, SERVICES, BRAND IDENTITY AND COMMERCIAL INFORMATION AND NEWS OF THIRD PARTIES THROUGH PRINT, AUDIO, VIDEO, DIGITAL AND ON-LINE MEDIUM; ADVERTISING CONSULTATION; ADVERTISING IN PERIODICALS, BROCHURES AND NEWSPAPERS; ADVERTISING IN THE POPULAR AND PROFESSIONAL PRESS; ADVERTISING ON THE INTERNET FOR OTHERS; ADVERTISING SERVICES; ADVERTISING SERVICES, NAMELY, PROMOTING THE BRANDS, GOODS AND SERVICES OF OTHERS; ADVERTISING SERVICES, NAMELY, PROVIDING ADVERTISING SPACE IN A PERIODICAL; ADVERTISING, MARKETING AND PROMOTION SERVICES; AGENCIES FOR ADVERTISING TIME AND SPACE; BANNER ADVERTISING; COMPILATION OF ADVERTISEMENTS FOR USE AS WEB PAGES ON THE INTERNET; INTERNET ADVERTISING SERVICES; MARKETING SERVICES, NAMELY, PROMOTING OR ADVERTISING THE

CLASS 35—(Continued).

GOODS AND SERVICES OF OTHERS; ON-LINE ADVERTISING ON COMPUTER COMMUNICATION NETWORKS; ON-LINE ADVERTISING ON COMPUTER NETWORKS; ON-LINE ADVERTISING SERVICES FOR OTHERS; ONLINE ADVERTISEMENTS; ONLINE ADVERTISING AND PROMOTIONAL SERVICES; ONLINE ADVERTISING VIA A COMPUTER COMMUNICATIONS NETWORK; PLACING ADVERTISEMENTS FOR OTHERS; PREPARATION AND REALIZATION OF MEDIA AND ADVERTISING PLANS AND CONCEPTS; PREPARATION OF CUSTOM ADVERTISEMENTS FOR OTHERS; PREPARING ADVERTISEMENTS FOR OTHERS; PREPARING AND PLACING ADVERTISEMENTS FOR OTHERS; PREPARING AND PLACING ADVERTISEMENTS; PRODUCTION OF ADVERTISING MATTER AND COMMERCIALS; PROMOTING THE GOODS AND SERVICES OF OTHERS BY MEANS OF DISTRIBUTING ADVERTISING ON THE INTERNET; PROMOTING, ADVERTISING AND MARKETING OF THE BRANDS, PRODUCTS, SERVICES AND ONLINE WEBSITES OF INDIVIDUALS, BUSINESSES AND NON-PROFIT ORGANIZATIONS; PROMOTING, ADVERTISING AND MARKETING ON-LINE WEB SITES OF OTHERS; PROVIDING A SEARCHABLE ON-LINE ADVERTISING WEBSITE AND GUIDE FEATURING THE GOODS AND SERVICES OF OTHER VENDORS VIA THE INTERNET; PROVIDING A SEARCHABLE ONLINE ADVERTISING GUIDE FEATURING THE GOODS AND SERVICES OF ONLINE VENDORS; PROVIDING A WEB SITE WHICH FEATURES ADVERTISEMENTS FOR THE GOODS AND SERVICES OF OTHERS ON A GLOBAL COMPUTER NETWORK; PROVIDING ADVERTISING SPACE IN PERIODICALS, NEWSPAPERS AND MAGAZINES; PROVIDING AND RENTAL OF ADVERTISING SPACE ON THE INTERNET; PROVIDING ON-LINE BUSINESS INFORMATION OF OTHERS, NAMELY, ADVERTISEMENTS OR SOLICITATIONS; PROVIDING SPACE AT A WEB SITE FOR THE ADVERTISEMENT OF THE GOODS AND SERVICES OF OTHERS; PROVISION OF ADVERTISING SPACE BY ELECTRONIC MEANS AND GLOBAL INFORMATION NETWORKS; PROVISION OF SPACE ON WEBSITES FOR ADVERTISING GOODS AND SERVICES (U.S. CLS. 100, 101 AND 102).

FIRST USE 11-24-2009; IN COMMERCE 12-12-2010.
ALAIN LAPTER, EXAMINING ATTORNEY

SN 85-368,911. BEALE, RYAN G, DBA PURE MENTAL GRAFFITI, SOUTHFIELD, MI. FILED 7-12-2011.

Pure Mental Graffiti

THE MARK CONSISTS OF STANDARD CHARACTERS WITHOUT CLAIM TO ANY PARTICULAR FONT, STYLE, SIZE, OR COLOR.

FOR PROMOTING PUBLIC AWARENESS IN THE FIELD OF SOCIAL WELFARE (U.S. CLS. 100, 101 AND 102).

FIRST USE 3-10-2011; IN COMMERCE 5-1-2011.
SHANNON TWOHIG, EXAMINING ATTORNEY

CLASS 35—(Continued).

SN 85-370,208. PSP FRANCHISING, LLC, FARMINGTON HILLS, MI. FILED 7-13-2011.

PSP PREFERRED PET CLUB

THE MARK CONSISTS OF STANDARD CHARACTERS WITHOUT CLAIM TO ANY PARTICULAR FONT, STYLE, SIZE, OR COLOR.

NO CLAIM IS MADE TO THE EXCLUSIVE RIGHT TO USE "PREFERRED PET CLUB", APART FROM THE MARK AS SHOWN.

FOR MEMBERSHIP CLUB SERVICES THAT PROVIDE INCENTIVE AWARD PROGRAMS FOR CUSTOMERS THROUGH THE ISSUANCE AND PROCESSING OF LOYALTY COUPONS FOR FREQUENT USE OF PARTICIPATING BUSINESSES (U.S. CLS. 100, 101 AND 102).

FIRST USE 9-0-2009; IN COMMERCE 9-0-2009.
RAUL CORDOVA, EXAMINING ATTORNEY

CLASS 35—(Continued).

SN 85-372,817. DFIASS DUTY FREE AIR AND SHIP SUPPLY, CO., MIAMI, FL. FILED 7-15-2011.

SKY SHOPPING

THE MARK CONSISTS OF STANDARD CHARACTERS WITHOUT CLAIM TO ANY PARTICULAR FONT, STYLE, SIZE, OR COLOR.

NO CLAIM IS MADE TO THE EXCLUSIVE RIGHT TO USE "SHOPPING", APART FROM THE MARK AS SHOWN.

FOR IN-FLIGHT AND MAIL ORDER CATALOG SERVICES IN THE FIELD OF DUTY-FREE GOODS, NAMELY, FRAGRANCES, COSMETICS, HANDBAGS, TOBACCO PRODUCTS, JEWELRY, ALCOHOLIC BEVERAGES AND ELECTRONIC GOODS; COMPUTERIZED ONLINE RETAIL STORE SERVICES IN THE FIELD OF DUTY-FREE GOODS, NAMELY, FRAGRANCES, COSMETICS, HANDBAGS, TOBACCO PRODUCTS, JEWELRY, ALCOHOLIC BEVERAGES AND ELECTRONIC GOODS (U.S. CLS. 100, 101 AND 102).

FIRST USE 4-15-2011; IN COMMERCE 4-15-2011.
BERYL GARDNER, EXAMINING ATTORNEY

SN 85-373,219. THOMAS, DESZERA M., DBA DESZERA MARTINELLE, POWDER SPRINGS, GA. FILED 7-16-2011.

SN 85-372,802. DFIASS DUTY FREE AIR AND SHIP SUPPLY, CO., MIAMI, FL. FILED 7-15-2011.

TAKE OFF AND SAVE

THE MARK CONSISTS OF STANDARD CHARACTERS WITHOUT CLAIM TO ANY PARTICULAR FONT, STYLE, SIZE, OR COLOR.

FOR IN-FLIGHT AND MAIL ORDER CATALOG SERVICES IN THE FIELD OF DUTY-FREE GOODS, NAMELY, FRAGRANCES, COSMETICS, HANDBAGS, TOBACCO PRODUCTS, JEWELRY, ALCOHOLIC BEVERAGES AND ELECTRONIC GOODS; COMPUTERIZED ONLINE RETAIL STORE SERVICES IN THE FIELD OF DUTY-FREE GOODS, NAMELY, FRAGRANCES, COSMETICS, HANDBAGS, TOBACCO PRODUCTS, JEWELRY, ALCOHOLIC BEVERAGES AND ELECTRONIC GOODS (U.S. CLS. 100, 101 AND 102).

FIRST USE 4-15-2011; IN COMMERCE 4-15-2011.
BERYL GARDNER, EXAMINING ATTORNEY



Dainty Deszerae Productions

NO CLAIM IS MADE TO THE EXCLUSIVE RIGHT TO USE "PRODUCTIONS", APART FROM THE MARK AS SHOWN.

THE NAME "DESZERA" IDENTIFIES A LIVING INDIVIDUAL WHOSE CONSENT IS OF RECORD.

THE COLOR(S) FUCHSIA, DARK FUCHSIA, LIGHT BROWN, LAVENDER, LIGHT PINK, SILVER, WHITE, DARK PINK, BLACK IS/ARE CLAIMED AS A FEATURE OF THE MARK.

THE MARK CONSISTS OF THE FIGURES OF TWO POSING HIGH HEEL SHOES WITH THE WOMAN'S LEGGINGS EXPOSED. A SHADOW IS UNDERNEATH THE FRONT PORTION OF THE LEFT SHOE. THE HIGH HEEL ON THE LEFT IS SLIGHTLY FACING FORWARD, AND THE HIGH HEEL ON THE RIGHT IS TURNED TO THE RIGHT. THE HEEL OF THE LEFT SHOE'S FRONTAL BOTTOM IS EXPOSED AND IT IS BLACK. THE LEGGINGS ARE THE COLOR FUCHSIA. THE SKIN OF THE FEET IN THE HIGH HEELS IS LIGHT BROWN. THE HEELS ARE DARK PINK WITH A LAVENDER MIX. THE BOTTOMS OF

CLASS 35—(Continued).

THE HIGH HEELS ARE DARK FUCHSIA MIXED WITH BLACK AND HAVE A GLITTER-LIKE QUALITY. THE RIGHT HIGH HEEL HAS A SPARKLY SILVER AND WHITE CURSIVE LETTER "D" ON THE TOP SIDE OF THE HEEL TOWARDS THE FRONT OF THE HIGH HEEL SHOE. UNDERNEATH BOTH HIGH HEEL SHOES IT SAYS, "DAINTY DESZERAЕ PRODUCTIONS" IN A LIGHT PINK CURLY FONT. THE REMAINDER OF THE WHITE IN THE DRAWING REPRESENTS BACKGROUND OR TRANSPARENT AREAS ONLY AND IS NOT PART OF THE MARK.

FOR ADVERTISING AND MARKETING SERVICES PROVIDED BY MEANS OF INDIRECT METHODS OF MARKETING COMMUNICATIONS, NAMELY, SOCIAL MEDIA, SEARCH ENGINE MARKETING, INQUIRY MARKETING, INTERNET MARKETING, MOBILE MARKETING, BLOGGING AND OTHER FORMS OF PASSIVE, SHARABLE OR VIRAL COMMUNICATIONS CHANNELS (U.S. CLS. 100, 101 AND 102).

MAUREEN DALL, EXAMINING ATTORNEY

SN 85-374,560. SEMPRIS, LLC, MINNEAPOLIS, MN. FILED 7-19-2011.

@HOME FUN

THE MARK CONSISTS OF STANDARD CHARACTERS WITHOUT CLAIM TO ANY PARTICULAR FONT, STYLE, SIZE, OR COLOR.

NO CLAIM IS MADE TO THE EXCLUSIVE RIGHT TO USE "@HOME", APART FROM THE MARK AS SHOWN.

FOR BUYING CLUB SERVICES; ONLINE, PHONE AND MAIL ORDER SERVICES FOR GOODS AND SERVICES, INCLUDING THE PROVISION OF MERCHANDISE AND SERVICES DISCOUNTS AND ORDER SAVINGS CERTIFICATES, ALL FEATURING GENERAL MERCHANDISE AND SERVICES; PROMOTING THE SALE OF THE GOODS AND SERVICES OF OTHERS THROUGH THE DISTRIBUTION OF COUPONS AND DISCOUNT OFFERS (U.S. CLS. 100, 101 AND 102).

FIRST USE 1-2-2010; IN COMMERCE 1-2-2010.
THOMAS MANOR, EXAMINING ATTORNEY

SN 85-374,863. SUPERVALU INC., EDEN PRAIRIE, MN. FILED 7-19-2011.

PLENTY FOR TWENTY

THE MARK CONSISTS OF STANDARD CHARACTERS WITHOUT CLAIM TO ANY PARTICULAR FONT, STYLE, SIZE, OR COLOR.

FOR RETAIL GROCERY STORE SERVICES (U.S. CLS. 100, 101 AND 102).

FIRST USE 7-1-2011; IN COMMERCE 7-1-2011.
CAROLINE WOOD, EXAMINING ATTORNEY

CLASS 35—(Continued).

SN 85-374,917. EZ POLICE REPORTS, LLC, AKA MYFREE-POLICEREPORT.COM, PARAMUS, NJ. FILED 7-19-2011.



NO CLAIM IS MADE TO THE EXCLUSIVE RIGHT TO USE "MYFREEPOLICEREPORT.COM", APART FROM THE MARK AS SHOWN.

THE MARK CONSISTS OF AN OUTLINE OF THE TOP OF A CAR WITH THE WORDS: "MYFREEPOLICEREPORT.COM" UNDERNEATH.

FOR PROVIDING CONSUMER INFORMATION, NAMELY, PROVISION OF FREE AUTOMOBILE ACCIDENT REPORTS; INTERNET ADVERTISING (U.S. CLS. 100, 101 AND 102).

FIRST USE 7-19-2011; IN COMMERCE 7-19-2011.
MARK RADEMACHER, EXAMINING ATTORNEY

SN 85-382,120. I'M IN YOUR POCKET, LLC, CIBOLO, TX. FILED 7-27-2011.

I'm In Your Pocket

THE MARK CONSISTS OF STANDARD CHARACTERS WITHOUT CLAIM TO ANY PARTICULAR FONT, STYLE, SIZE, OR COLOR.

FOR COMPUTERIZED ON-LINE RETAIL STORE SERVICES IN THE FIELD OF SOUVENIR PRESSED COINS (U.S. CLS. 100, 101 AND 102).

FIRST USE 7-12-2011; IN COMMERCE 7-12-2011.
GISELLE AGOSTO, EXAMINING ATTORNEY

SN 85-383,232. FARM PROGRESS COMPANIES, INC., ST. CHARLES, IL. FILED 7-28-2011.

USAGRICULTURE BRANDFILE

THE MARK CONSISTS OF STANDARD CHARACTERS WITHOUT CLAIM TO ANY PARTICULAR FONT, STYLE, SIZE, OR COLOR.

OWNER OF U.S. REG. NO. 1,762,207.

SEC. 2(F).

FOR PROVIDING BUSINESS INFORMATION AND ADVICE FROM THE RESULTS OF AN ANNUAL SURVEY OF AGRICULTURE PRODUCERS IDENTIFYING BRAND SPECIFIC INFORMATION OF CROP INPUTS/ DATA AND LIVESTOCK INPUTS/DATA (U.S. CLS. 100, 101 AND 102).

FIRST USE 8-1-2004; IN COMMERCE 8-1-2004.

TIMOTHY FINNEGAN, EXAMINING ATTORNEY

CLASS 35—(Continued).

SN 85-386,164. GIFT BASKETS WITH STYLE, LLC, PHOENIX, AZ. FILED 8-1-2011.

GIFT BASKETS WITH STYLE

THE MARK CONSISTS OF STANDARD CHARACTERS WITHOUT CLAIM TO ANY PARTICULAR FONT, STYLE, SIZE, OR COLOR.

NO CLAIM IS MADE TO THE EXCLUSIVE RIGHT TO USE "GIFT BASKETS", APART FROM THE MARK AS SHOWN.

FOR RETAIL STORE SERVICES FOR SELLING GOURMET AND THEMED GIFT BASKETS (U.S. CLS. 100, 101 AND 102).

FIRST USE 10-1-2004; IN COMMERCE 10-1-2004.
CHARLOTTE CORWIN, EXAMINING ATTORNEY

SN 85-388,705. CREDIT UNION NATIONAL ASSOCIATION, INC., MADISON, WI. FILED 8-3-2011.

CREDIT UNION NATIONAL ASSOCIATION

THE MARK CONSISTS OF STANDARD CHARACTERS WITHOUT CLAIM TO ANY PARTICULAR FONT, STYLE, SIZE, OR COLOR.

NO CLAIM IS MADE TO THE EXCLUSIVE RIGHT TO USE "ASSOCIATION", APART FROM THE MARK AS SHOWN.

SEC. 2(F).

FOR ASSOCIATION SERVICES, NAMELY, PROMOTING THE INTERESTS OF CREDIT UNIONS AND THEIR MEMBERS; BUSINESS MANAGEMENT CONSULTING; BUSINESS RESEARCH SERVICES IN THE FIELD OF CREDIT UNIONS AND THEIR MEMBERS; LOBBYING SERVICES, NAMELY, PROMOTING THE INTERESTS OF CREDIT UNIONS AND THEIR MEMBERS IN THE FIELD OF LEGISLATION AND REGULATION; BUSINESS RESEARCH AND SURVEYS (U.S. CLS. 100, 101 AND 102).

FIRST USE 8-0-1934; IN COMMERCE 8-0-1934.
ANDREA BUTLER, EXAMINING ATTORNEY

CLASS 35—(Continued).

SN 85-388,824. RUZBEHJON, INC., LOS ANGELES, CA. FILED 8-3-2011.

Delphi Greek

THE MARK CONSISTS OF STANDARD CHARACTERS WITHOUT CLAIM TO ANY PARTICULAR FONT, STYLE, SIZE, OR COLOR.

NO CLAIM IS MADE TO THE EXCLUSIVE RIGHT TO USE "GREEK", APART FROM THE MARK AS SHOWN.

FOR ON-LINE ORDERING SERVICES IN THE FIELD OF RESTAURANT TAKE-OUT AND DELIVERY; RESTAURANT FRANCHISING, NAMELY, OFFERING BUSINESS MANAGEMENT ASSISTANCE IN THE ESTABLISHMENT AND/OR OPERATION OF RESTAURANTS (U.S. CLS. 100, 101 AND 102).

FIRST USE 1-1-1985; IN COMMERCE 1-1-1985.
KIMBERLY PERRY, EXAMINING ATTORNEY

SN 85-391,863. HUSNI, SAMIR A., OXFORD, MS. FILED 8-8-2011.

mr. magazine

THE MARK CONSISTS OF STANDARD CHARACTERS WITHOUT CLAIM TO ANY PARTICULAR FONT, STYLE, SIZE, OR COLOR.

NO CLAIM IS MADE TO THE EXCLUSIVE RIGHT TO USE "MAGAZINE", APART FROM THE MARK AS SHOWN. FOR BUSINESS CONSULTATION IN THE FIELD OF PUBLISHING (U.S. CLS. 100, 101 AND 102).

FIRST USE 1-15-1986; IN COMMERCE 1-1-1997.
FRED CARL, EXAMINING ATTORNEY

SN 85-392,174. ECS TUNING, INC., WADSWORTH, OH. FILED 8-8-2011.

ECS TUNING

THE MARK CONSISTS OF STANDARD CHARACTERS WITHOUT CLAIM TO ANY PARTICULAR FONT, STYLE, SIZE, OR COLOR.

NO CLAIM IS MADE TO THE EXCLUSIVE RIGHT TO USE "TUNING", APART FROM THE MARK AS SHOWN.

FOR ONLINE RETAIL STORE SERVICES FEATURING AUTOMOBILE PARTS AND ACCESSORIES (U.S. CLS. 100, 101 AND 102).

FIRST USE 11-15-2002; IN COMMERCE 11-15-2002.
COLLEEN KEARNEY, EXAMINING ATTORNEY

CLASS 35—(Continued).

SN 85-392,193. ECS TUNING, INC., WADSWORTH, OH. FILED 8-8-2011.



NO CLAIM IS MADE TO THE EXCLUSIVE RIGHT TO USE "TUNING", APART FROM THE MARK AS SHOWN.

THE MARK CONSISTS OF STYLIZED LETTERS "E", "C", AND "S", EACH IN AN INDIVIDUAL PARALLELOGRAM, ALL OVER THE WORD "TUNING".

FOR ONLINE RETAIL STORE SERVICES FEATURING AUTOMOBILE PARTS AND ACCESSORIES (U.S. CLS. 100, 101 AND 102).

FIRST USE 11-0-2004; IN COMMERCE 11-0-2004.

COLLEEN KEARNEY, EXAMINING ATTORNEY

SN 85-399,949. COBLENTZ DISTRIBUTING, INC., WALNUT CREEK, OH. FILED 8-17-2011.



OWNER OF U.S. REG. NO. 2,521,633.

THE COLOR(S) BLUE, WHITE, BLACK, RED, ORANGE, GRAY, GREEN, YELLOW, AND BROWN IS/ARE CLAIMED AS A FEATURE OF THE MARK.

THE MARK CONSISTS OF AN AMISH FARM SCENE SURROUNDED BY FOUR CONCENTRIC OVALS, WITH THE OUTER OVAL BEING BLUE, THE NEXT OVAL BEING WHITE, THE NEXT OVAL BEING BLUE, AND THE INNERMOST OVAL BEING WHITE AND FADING INTO THE FARM SCENE. A BLACK AMISH BUGGY WITH RED BLINKER LIGHTS AND AN ORANGE AND RED SLOW MOVING VEHICLE SIGN APPEARS IN THE FOREGROUND. THE BLACK HOOVES OF THE HORSE PULLING THE BUGGY ARE VISIBLE UNDER THE SLOW MOVING VEHICLE SIGN. THE BUGGY IS TRAVELING DOWN A GRAY DIRT LANE. A GREEN PINE TREE AND A TREE WITH YELLOW AND ORANGE LEAVES APPEAR TO THE LEFT OF THE BUGGY. A BROWN WOOD FENCE APPEARS TO THE RIGHT OF THE BUGGY, AND A TREE WITH BROWN BARK AND GREEN LEAVES GROWS ALONG THE FENCE. A CORNFIELD WITH BROWN CORN SHOCKS AND BROWN STANDING CORN APPEARS FARTHER DOWN THE LANE TO THE RIGHT. THERE IS GREEN GRASS TO BOTH THE LEFT AND THE RIGHT OF THE BUGGY, AND BEHIND THE CORNFIELD. YELLOW AND ORANGE LEAVES LITTER THE LANE IN FRONT OF THE BUGGY AND THE GRASS ON BOTH SIDES OF THE BUGGY. A TREE WITH BROWN BARK AND ORANGE FOLIAGE APPEARS BEHIND THE CORNFIELD TOWARDS THE UPPER RIGHT. TO THE RIGHT OF THAT TREE, A BARN WITH A BROWN BRICK FOUNDATION AND GRAY SIDING APPEARS. BELOW THE TREE, A WHITE METAL ROOF OF A SMALL SHED APPEARS. AT THE END OF THE LANE, A HOUSE WITH WHITE SIDING, TWO BLACK UPPER WINDOWS, AND A LOWER WINDOW COVERED IN BLUE APPEARS. A BARN WITH RED SIDING AND A GRAY ROOF APPEARS BEHIND THE HOUSE. A SILO

CLASS 35—(Continued).

WITH A WHITE BODY AND A GRAY ROOF APPEARS TO THE LEFT OF THE BARN. A GREEN PINE TREE APPEARS TO THE LEFT OF THE HOUSE. WITH TWO BLACK AMISH BUGGIES WITH ORANGE SLOW MOVING VEHICLE SIGNS SITTING BESIDE IT. A NUMBER OF TREES WITH GREEN LEAVES APPEAR ON A HILL BEHIND THE HOUSE AND BARN. THE SKY APPEARS ABOVE THE TREES IN WHITE. A BLUE AND WHITE RIBBON COVERS THE BOTTOM OF THE OVALS, WITH THE WORD "CHEESE" WRITTEN ON THE RIBBON IN WHITE. THE WORDS "WALNUT CREEK" APPEAR IN BLACK ABOVE THE OVALS AND FOLLOW THE CURVE OF THE OVALS. SEC. 2(F) AS TO "WALNUT CREEK CHEESE".

FOR RETAIL STORE AND ON-LINE RETAIL STORE SERVICES FEATURING A WIDE VARIETY OF CONSUMER GOODS OF OTHERS (U.S. CLS. 100, 101 AND 102).

FIRST USE 10-1-1996; IN COMMERCE 10-1-1996.

KATHERINE CONNOLLY, EXAMINING ATTORNEY

SN 85-400,393. ACCOUNTABILITY SERVICES LLC, SEATTLE, WA. FILED 8-17-2011.



ACCOUNTABILITY SERVICES

ACCOUNTING • TAXES • BUSINESS CONSULTING

NO CLAIM IS MADE TO THE EXCLUSIVE RIGHT TO USE "SERVICES", "ACCOUNTING", "TAXES" AND "BUSINESS CONSULTING", APART FROM THE MARK AS SHOWN.

THE STIPPLING IS FOR SHADING PURPOSES ONLY.

THE MARK CONSISTS OF A STYLIZED LETTER "A" CONTAINED WITHIN A LATTICE OF NINE BOXES, FOLLOWED BY THE WORDING "ACCOUNTABILITY SERVICES" ALSO CONTAINING THE STYLIZED LETTERS "A". THE WORDING "ACCOUNTING TAXES BUSINESS CONSULTING" APPEARS BENEATH THE WORDING "ACCOUNTABILITY SERVICES". SMALL CIRCULAR DOTS APPEAR IN BETWEEN THE WORDS "ACCOUNTING" AND "TAXES" AND "BUSINESS CONSULTING".

FOR ACCOUNTING SERVICES; BUSINESS INFORMATION AND ACCOUNTING ADVISORY SERVICES; TAX PREPARATION (U.S. CLS. 100, 101 AND 102).

FIRST USE 12-15-2005; IN COMMERCE 12-15-2005.

ANDREW RHIM, EXAMINING ATTORNEY

CLASS 35—(Continued).

SN 85-404,490. WHITE BAY PARTNERS, LLC, CHARLOTTESVILLE, VA. FILED 8-23-2011.



THE MARK CONSISTS OF THREE PALM TREES. FOR ON-LINE RETAIL STORE SERVICES FEATURING SOUVENIRS, CLOTHING AND APPAREL, CLOTHING AND FASHION ACCESSORIES, CAPS, HATS, BOOKS, PRINTS, CALENDARS, COOKBOOKS, PUZZLES, GAMES, TOYS, TUMBLERS, GLASSWARE, BEVERAGEWARE, DRINKWARE, CAN AND BOTTLE HOLDERS, INSULATED CONTAINERS FOR BEVERAGE CANS, STICKERS, KEYCHAINS, JEWELRY, WALLET, BLANKETS, FLAGS, TOTE BAGS, PURSES (U.S. CLS. 100, 101 AND 102).

FIRST USE 2-28-2002; IN COMMERCE 2-28-2002.
CHARLES L. JENKINS, EXAMINING ATTORNEY

SN 85-406,482. ALPHABIRD, SAN FRANCISCO, CA. FILED 8-24-2011.

Alphabird

THE MARK CONSISTS OF THE WORD "ALPHABIRD" IN PLAIN ARIAL FONT.

FOR ADVERTISING, MARKETING AND PROMOTION SERVICES IN THE FIELD OF ONLINE VIDEO DISTRIBUTION ACROSS PREMIUM PUBLISHERS; DEVELOPMENT OF MARKETING STRATEGIES, CONCEPTS AND TACTICS, NAMELY, AUDIENCE DEVELOPMENT, BRAND AWARENESS, ONLINE COMMUNITY BUILDING AND DIGITAL WORD OF MOUTH COMMUNICATIONS (U.S. CLS. 100, 101 AND 102).

FIRST USE 1-22-2007; IN COMMERCE 1-22-2007.
GEOFFREY FOSDICK, EXAMINING ATTORNEY

CLASS 35—(Continued).

SN 85-406,830. SESSO, LYDIA, SINGER ISLAND, FL. FILED 8-25-2011.



THE STIPPLING IS FOR SHADING PURPOSES ONLY. THE MARK CONSISTS OF A VICTORIAN FLOWER CART FILLED WITH MUMS, ROSES, DAFFODILS, AND CASCADING HOLLY ALONG WITH A POLE ATTACHED, WHICH HANGS A POLKA DOTTED HAT FILLED WITH DAFFODILS AND CURLY BRANCHES.

FOR ONLINE RETAIL STORE SERVICES FEATURING FLOWER ARRANGEMENTS IN POTS WHICH ARE CUSTOM DESIGNED TO HAVE THE APPEARANCE OF SEASONAL HATS (U.S. CLS. 100, 101 AND 102).
WENDY GOODMAN, EXAMINING ATTORNEY

SN 85-408,035. JOHN COFFMAN, PARKER, CO. AND JAIME COFFMAN, PARKER, CO. FILED 8-26-2011.

Fro Yo Spot

THE MARK CONSISTS OF STANDARD CHARACTERS WITHOUT CLAIM TO ANY PARTICULAR FONT, STYLE, SIZE, OR COLOR.

NO CLAIM IS MADE TO THE EXCLUSIVE RIGHT TO USE "FRO YO", APART FROM THE MARK AS SHOWN.

FOR SHOPS FEATURING SELF-SERVE FROZEN YOGURT AND FROZEN YOGURT TOPPING; AND FRANCHISE SERVICES, NAMELY, OFFERING BUSINESS MANAGEMENT ASSISTANCE IN THE ESTABLISHMENT AND OPERATION OF SELF-SERVE FROZEN YOGURT SHOPS (U.S. CLS. 100, 101 AND 102).

FIRST USE 8-9-2011; IN COMMERCE 8-9-2011.
MARILYN IZZI, EXAMINING ATTORNEY

CLASS 35—(Continued).

SN 85-408,076. JOHN COFFMAN, PARKER, CO. AND JAIME COFFMAN, PARKER, CO. FILED 8-26-2011.



NO CLAIM IS MADE TO THE EXCLUSIVE RIGHT TO USE "FRO YO", APART FROM THE MARK AS SHOWN.

THE MARK CONSISTS OF A CIRCLE SHAPE IN WHICH THERE IS SWIRLED YOGURT, WITH A STRAWBERRY PARTIALLY OVERLAPPING THE TOP RIGHT SIDE OF THE CIRCLE, AND, TO THE IMMEDIATE RIGHT OF THE CIRCLE SHAPE, THE WORDS "FRO YO SPOT" IN STYLIZED LOWER CASE LETTERS.

FOR SHOPS FEATURING SELF-SERVE FROZEN YOGURT AND FROZEN YOGURT TOPPINGS; AND FRANCHISE SERVICES, NAMELY, OFFERING BUSINESS MANAGEMENT ASSISTANCE IN THE ESTABLISHMENT AND OPERATION OF SELF-SERVE FROZEN YOGURT SHOPS (U.S. CLS. 100, 101 AND 102).
FIRST USE 8-9-2011; IN COMMERCE 8-9-2011.

MARILYN IZZI, EXAMINING ATTORNEY

CLASS 35—(Continued).

SN 85-408,981. NETOTIATE INC., NEWTON UPPER FALLS, MA. FILED 8-27-2011.

NETOTIATE

THE MARK CONSISTS OF STANDARD CHARACTERS WITHOUT CLAIM TO ANY PARTICULAR FONT, STYLE, SIZE, OR COLOR.

FOR NEGOTIATION AND SETTLEMENT OF COMMERCIAL TRANSACTIONS FOR THIRD PARTIES AND NEGOTIATION AND SETTLEMENT OF COMMERCIAL TRANSACTIONS FOR THIRD PARTIES PROVIDED ON-LINE VIA COMPUTER PLATFORM (U.S. CLS. 100, 101 AND 102).

JASON TURNER, EXAMINING ATTORNEY

SN 85-408,617. HARLEY LEGAL SEARCH, INC., NEW YORK, NY. FILED 8-26-2011.

HARLEY LEGAL SEARCH

THE MARK CONSISTS OF STANDARD CHARACTERS WITHOUT CLAIM TO ANY PARTICULAR FONT, STYLE, SIZE, OR COLOR.

NO CLAIM IS MADE TO THE EXCLUSIVE RIGHT TO USE "LEGAL SEARCH", APART FROM THE MARK AS SHOWN.

FOR ATTORNEY RECRUITING AND JOB PLACEMENT SERVICES; ATTORNEY SEARCH SERVICES FOR PURPOSES OF PLACEMENT IN PERMANENT JOBS; PROVIDING EMPLOYMENT COUNSELING INFORMATION ON HOW TO SUCCESSFULLY TRANSITION JOBS PROVIDED TO ATTORNEYS; EMPLOYMENT COUNSELING IN THE FIELD OF LAW (U.S. CLS. 100, 101 AND 102).

FIRST USE 1-11-2011; IN COMMERCE 1-11-2011.

SUNG IN, EXAMINING ATTORNEY

SN 85-409,223. LOENNGREN, LARS-RENE, BARCELONA, SPAIN, FILED 8-29-2011.

speeb

THE MARK CONSISTS OF STANDARD CHARACTERS WITHOUT CLAIM TO ANY PARTICULAR FONT, STYLE, SIZE, OR COLOR.

THE WORDING "SPEEB" HAS NO MEANING IN A FOREIGN LANGUAGE.

FOR ADVERTISING AND PUBLICITY SERVICES, NAMELY, PROMOTING THE GOODS, SERVICES, BRAND IDENTITY AND COMMERCIAL INFORMATION AND NEWS OF THIRD PARTIES THROUGH PRINT, AUDIO, VIDEO, DIGITAL AND ON-LINE MEDIUM (U.S. CLS. 100, 101 AND 102).

FIRST USE 4-7-2011; IN COMMERCE 4-7-2011.

ELLEN PERKINS, EXAMINING ATTORNEY

CLASS 35—(Continued).

SN 85-409,347. GLOBAL TEL*LINK CORPORATION, MOBILE, AL. FILED 8-29-2011.



THE COLOR(S) BLUE, BLACK AND SILVER IS/ARE CLAIMED AS A FEATURE OF THE MARK.

THE MARK CONSISTS OF TWO SILVER CIRCLES WITH THE WORDING "TIP" INSIDE THE INNER CIRCLE IN BLACK, BLUE AND SILVER AND A BLUE RIBBON DESIGN AT THE BOTTOM OF THE CIRCLE WITH THE WORDING "CERTIFIED" IN BLACK, SILVER AND BLUE.

FOR ARRANGING AND CONDUCTING INCENTIVE REWARD PROGRAMS TO PROMOTE THE SALE OF TELECOMMUNICATIONS, MONITORING, DATABASE MANAGEMENT, AND FINANCIAL SOFTWARE AND SERVICES FOR CORRECTIONAL INSTITUTIONS (U.S. CLS. 100, 101 AND 102).

FIRST USE 9-30-2009; IN COMMERCE 9-30-2009.
REGINA DRUMMOND, EXAMINING ATTORNEY

SN 85-409,796. RAWLINGS SPORTING GOODS COMPANY, INC., ST. LOUIS, MO. FILED 8-29-2011.

FROM THE SANDLOT TO THE
BIG LEAGUES

THE MARK CONSISTS OF STANDARD CHARACTERS WITHOUT CLAIM TO ANY PARTICULAR FONT, STYLE, SIZE, OR COLOR.

FOR RETAIL STORES SERVICES IN THE FIELD OF BASEBALL AND SOFTBALL RELATED PRODUCTS (U.S. CLS. 100, 101 AND 102).

FIRST USE 3-0-2011; IN COMMERCE 3-0-2011.
EVELYN BRADLEY, EXAMINING ATTORNEY

SN 85-411,228. KELLEX CORPORATION, NORTH RIDGEVILLE, OH. FILED 8-30-2011.

Hour America

THE MARK CONSISTS OF STANDARD CHARACTERS WITHOUT CLAIM TO ANY PARTICULAR FONT, STYLE, SIZE, OR COLOR.

NO CLAIM IS MADE TO THE EXCLUSIVE RIGHT TO USE "AMERICA", APART FROM THE MARK AS SHOWN.

FOR ADVERTISING AGENCIES SPECIALIZING IN CREATING JOBS AND THE HOURS OF LABOR INVOLVED IN BUYING A US PRODUCED PRODUCT (U.S. CLS. 100, 101 AND 102).

KEVON CHISOLM, EXAMINING ATTORNEY

CLASS 35—(Continued).

SN 85-411,730. OHIO FARM BUREAU FEDERATION, INC., COLUMBUS, OH. FILED 8-31-2011.

ANIMALS FOR LIFE FOUNDATION

THE MARK CONSISTS OF STANDARD CHARACTERS WITHOUT CLAIM TO ANY PARTICULAR FONT, STYLE, SIZE, OR COLOR.

NO CLAIM IS MADE TO THE EXCLUSIVE RIGHT TO USE "ANIMALS" AND "FOUNDATION", APART FROM THE MARK AS SHOWN.

FOR ASSOCIATION SERVICES, NAMELY, PROMOTING PUBLIC AWARENESS OF THE VALUE ANIMALS BRING TO HUMAN LIFE AND THE CARE HUMANS GIVE THEIR ANIMALS, TO INCREASE PUBLIC ACCEPTANCE AND UNDERSTANDING OF HUMAN-ANIMAL INTERDEPENDENCY, AND ACHIEVE PUBLIC RECOGNITION THAT ANIMALS BRING VALUE TO HUMAN LIFE WHILE STRIVING TO IMPROVE THE QUALITY OF LIFE FOR EACH (U.S. CLS. 100, 101 AND 102).

FIRST USE 12-14-2009; IN COMMERCE 12-14-2009.
LINDA M. KING, EXAMINING ATTORNEY

SN 85-412,386. APPBACKR INC., PALO ALTO, CA. FILED 8-31-2011.

SMART10

THE MARK CONSISTS OF STANDARD CHARACTERS WITHOUT CLAIM TO ANY PARTICULAR FONT, STYLE, SIZE, OR COLOR.

FOR PROVIDING A WEBSITE FOR CONNECTING SELLERS, IN THE NATURE OF MOBILE APPLICATION DEVELOPERS, WITH BUYERS OF MOBILE APPLICATIONS; PROVIDING ONLINE CONSUMER INFORMATION REGARDING MOBILE APPLICATIONS TO DEVELOPERS, BUYERS AND DISTRIBUTORS (U.S. CLS. 100, 101 AND 102).

FIRST USE 8-24-2011; IN COMMERCE 8-24-2011.
RUDY R. SINGLETON, EXAMINING ATTORNEY

CLASS 35—(Continued).

SN 85-412,546. CERTIPRO INC., INDEPENDENCE, MN. FILED 9-1-2011.



NO CLAIM IS MADE TO THE EXCLUSIVE RIGHT TO USE "INC.", APART FROM THE MARK AS SHOWN.

THE COLOR(S) BLACK, RED, AND GRAY IS/ARE CLAIMED AS A FEATURE OF THE MARK.

THE MARK CONSISTS OF "CERTIPRO" IS ITALICIZED WITH A CAPITAL "C" AND A CAPITAL "P". "CERTI" IS IN BLACK, AND "PRO", WHICH IS POSITIONED SLIGHTLY BELOW "CERT", IS IN RED. "CERTIPRO" HAS A LIGHT GRAY SHADOW. "INC." IS SMALL AND POSITIONED TO THE RIGHT OF THE LETTER "O".

FOR ADVERTISING AND DIRECTORY SERVICES, NAMELY, PROMOTING THE SERVICES OF OTHERS BY PROVIDING A WEB PAGE FEATURING LINKS TO THE WEBSITES OF OTHERS (U.S. CLS. 100, 101 AND 102).

FIRST USE 4-1-2008; IN COMMERCE 4-1-2008.
HOWARD SMIGA, EXAMINING ATTORNEY

CLASS 35—(Continued).

SN 85-417,622. HOUSTON WIRE & CABLE COMPANY, HOUSTON, TX. FILED 9-8-2011.

RIGHT PRODUCT RIGHT PLACE
RIGHT TIME

THE MARK CONSISTS OF STANDARD CHARACTERS WITHOUT CLAIM TO ANY PARTICULAR FONT, STYLE, SIZE, OR COLOR.

FOR BUSINESS CONSULTATION IN THE WIRE AND CABLE INDUSTRY; INVENTORY MANAGEMENT IN THE FIELD OF WIRE AND CABLE DISTRIBUTION; DISTRIBUTORSHIPS IN THE FIELD OF WIRE AND CABLE; DISTRIBUTORSHIPS IN THE FIELD OF VOICE, VIDEO, DATA, FIBER, AND CENTRAL OFFICE POWER CABLE AND WIRE AND CABLE CONNECTORS AND TERMINATORS; ARRANGING CONTRACTS FOR THE MANUFACTURE OF SPECIALTY WIRE FOR OTHERS (U.S. CLS. 100, 101 AND 102).

FIRST USE 4-5-2007; IN COMMERCE 4-5-2007.
PATRICIA EVANKO, EXAMINING ATTORNEY

SN 85-417,733. VOLUNTEER CENTER OF NORTH TEXAS, DALLAS, TX. FILED 9-8-2011.

SN 85-416,872. SPLASH LAB, INC., LAS VEGAS, NV. FILED 9-7-2011.



THE COLOR(S) YELLOW, BLUE, GRAY AND WHITE IS/ARE CLAIMED AS A FEATURE OF THE MARK.

THE MARK CONSISTS OF THE BLUE WORDS AND NUMBER "PRICESARCH4" TO THE RIGHT OF A YELLOW STYLIZED BAG WITH THE WHITE LETTERS "PS" AND THE WHITE NUMBER 4 ON THE LOWER PORTION OF THE BAG AND BELOW THE BLUE WORDS ARE THE GRAY WORDS AND NUMBER BEFORE YOU BUY IT, "PS4 IT!"

FOR SHOPPING FACILITATION SERVICES, NAMELY, PROVIDING AN ONLINE COMPARISON-SHOPPING SEARCH ENGINE FOR OBTAINING PURCHASING INFORMATION (U.S. CLS. 100, 101 AND 102).

FIRST USE 5-13-2008; IN COMMERCE 5-13-2008.
WANDA KAY PRICE, EXAMINING ATTORNEY



THE COLOR(S) RED AND BLACK IS/ARE CLAIMED AS A FEATURE OF THE MARK.

THE MARK CONSISTS OF THE WORDS "I AM" DISPLAYED IN LOWERCASE LETTERS ABOVE THE WORDS "A VOLUNTEER", WHERE THE "A" IS LOWERCASE LETTERS AND "VOLUNTEER" IS IN UPPERCASE LETTERS. THE "I" IN THE TOP ROW AND "VOLUNTEER" IN THE BOTTOM ROW APPEAR IN BLACK. THE "AM" IN THE TOP ROW AND "A" IN THE BOTTOM ROW APPEAR IN RED. BOTH ROWS EXTEND TO THE SAME WIDTH. AND, THE TOP ROW IS APPROXIMATELY 130% THE SIZE OF THE BOTTOM ROW.

FOR CHARITABLE SERVICES, NAMELY, PROMOTING VOLUNTEERISM IN SUPPORT OF THE MISSION STATEMENT OF THE VOLUNTEER CENTER OF NORTH TEXAS TO TRANSFORM COMMUNITIES BY STRENGTHENING NONPROFITS THROUGH VOLUNTEERS (U.S. CLS. 100, 101 AND 102).

FIRST USE 4-15-2011; IN COMMERCE 4-15-2011.
MICHAEL ENGEL, EXAMINING ATTORNEY

CLASS 35—(Continued).

SN 85-419,245. E.D. MARSHALL, INC., SCOTTSDALE, AZ. FILED 9-9-2011.

E. D. MARSHALL JEWELERS

THE MARK CONSISTS OF STANDARD CHARACTERS WITHOUT CLAIM TO ANY PARTICULAR FONT, STYLE, SIZE, OR COLOR.

NO CLAIM IS MADE TO THE EXCLUSIVE RIGHT TO USE "JEWELERS", APART FROM THE MARK AS SHOWN. THE NAME "E.D. MARSHALL" IDENTIFIES A LIVING INDIVIDUAL WHOSE CONSENT IS OF RECORD.

FOR WHOLESALE AND RETAIL STORE SERVICES FEATURING JEWELRY (U.S. CLS. 100, 101 AND 102).

FIRST USE 0-0-1980; IN COMMERCE 0-0-1980.

MARIA-VICTORIA SUAREZ, EXAMINING ATTORNEY

SN 85-419,285. E.D. MARSHALL, INC., SCOTTSDALE, AZ. FILED 9-9-2011.



NO CLAIM IS MADE TO THE EXCLUSIVE RIGHT TO USE "JEWELERS" AND "SINCE 1971", APART FROM THE MARK AS SHOWN.

THE NAME "E.D. MARSHALL" IDENTIFIES A LIVING INDIVIDUAL WHOSE CONSENT IS OF RECORD.

THE MARK CONSISTS OF A BUILDING PICTURE WITH THE WORDS "SINCE 1971" TO ITS RIGHT, AND THE WORDS "E. D. JEWELERS" UNDERNEATH.

FOR WHOLESALE AND RETAIL STORE SERVICES FEATURING JEWELRY (U.S. CLS. 100, 101 AND 102).

FIRST USE 0-0-1980; IN COMMERCE 0-0-1980.

MARIA-VICTORIA SUAREZ, EXAMINING ATTORNEY

SN 85-420,041. STARLEY, BARBARA, GILBERT, AZ. FILED 9-12-2011.



THE MARK CONSISTS OF AN IMAGE OF A PERSON ON THE LETTER "O" IN THE TEXT "ONE", WITH THE TEXT "THEPOWEROFONE" ON A RECTANGULAR BACKGROUND BELOW "ONE".

FOR PROVIDING A WEBSITE FEATURING BUSINESS ADVICE FOR ENTREPRENEURS (U.S. CLS. 100, 101 AND 102).

FIRST USE 3-4-2010; IN COMMERCE 5-22-2010.

CARYN GLASSER, EXAMINING ATTORNEY

CLASS 35—(Continued).

SN 85-420,388. LENDERS MATCH, LLC, GULFPORT, MS. FILED 9-12-2011.



THE COLOR(S) WHITE, GRAY, LIGHT GRAY, GREEN, AND ORANGE IS/ARE CLAIMED AS A FEATURE OF THE MARK.

THE MARK CONSISTS OF A GRAY BACKGROUND WITH AN ABSTRACT ROOF OF A HOUSE CONTAINED IN A CIRCLE WITH GREEN ABOVE THE ROOF, THE PEAK OF THE ROOF, CHIMNEY AND WINDOW PANE IN LIGHT GRAY, AS IS THE ENCOMPASSING CIRCLE. ALL HOVERING ABOVE A LIGHT GRAY SHADOW, WITH THE PHRASE "LENDERS MATCH" CENTERED BELOW WITH "LENDERS" IN WHITE AND "MATCH" IN ORANGE, FOLLOWED BY, CENTERED ON THE BOTTOM, A LINE IN WHITE, THE PHRASE "FIND YOUR MATCH" IN WHITE AND ANOTHER LINE IN WHITE.

FOR ADVERTISING ON THE INTERNET FOR OTHERS; ON-LINE ADVERTISING SERVICES FOR OTHERS (U.S. CLS. 100, 101 AND 102).

MARK T. MULLEN, EXAMINING ATTORNEY

SN 85-420,425. CU* ANSWERS, INC., GRAND RAPIDS, MI. FILED 9-12-2011.



THE MARK CONSISTS OF AN ASTERISK NEXT TO THE WORDS "CUASTERISK.COM".

FOR BUSINESS CONSULTATION WITH RESPECT TO THE CREATION OF CREDIT UNION SERVICE ORGANIZATIONAL STARTUPS; BUSINESS NETWORKING SERVICES FOR CREDIT UNION SERVICE ORGANIZATIONAL STARTUPS (U.S. CLS. 100, 101 AND 102).

FIRST USE 9-30-2006; IN COMMERCE 9-30-2006.

CHARLES L. JENKINS, EXAMINING ATTORNEY

CLASS 35—(Continued).

SN 85-420,906. PALMER, MICHAEL F, PLEASANTON, CA.
FILED 9-12-2011.



OWNER OF U.S. REG. NO. 3,851,082.

NO CLAIM IS MADE TO THE EXCLUSIVE RIGHT TO USE "ENERGY SYSTEMS", APART FROM THE MARK AS SHOWN.

THE COLOR(S) BLUE, GOLD, BRONZE, WHITE, RED AND GREY IS/ARE CLAIMED AS A FEATURE OF THE MARK.

THE MARK CONSISTS OF A BLUE CIRCLE SURROUNDING A WHITE MIDDLE CIRCLE, UPON WHICH APPEARS A BRONZE INNER SPHERE WITH TWO STAR-SHAPED IMAGES APPEARING THEREON IN THE COLORS GOLD AND BRONZE, WITH THE POINTS OF ONE STAR LOCATED BEHIND THE BLUE CIRCLE AND THE OTHER SUPERIMPOSED IN FRONT OF THE BLUE CIRCLE; TO THE RIGHT OF THE AFOREMENTIONED APPEARS THE WORD "EQUINOX" IN BLUE WITH A GRAY SHADOW, WITH THE WORDING SHOWN IN ALL CAPITAL LETTERS AND WITH THE FIRST LETTER BEING A LARGER FONT THAN THE TRAILING LETTERS. BENEATH THE AFOREMENTIONED WORD APPEARS THE WORDS "ENERGY SYSTEMS" IN RED WITH A GRAY SHADOW, WITH THE WORDING SHOWN IN ALL CAPITAL LETTERS AND WITH THE FIRST LETTER OF EACH WORD BEING LARGER THAN THE TRAILING LETTERS.

FOR BUSINESS SERVICES, NAMELY, PROVIDING AN ONLINE NETWORK FOR CONTRACTORS TO RECEIVE LEADS AND BIDDING OPPORTUNITIES BY MEANS OF AN ONLINE MARKETPLACE FOR THE PURPOSE OF DEVELOPING BUSINESS FOR ENERGY RELATED PRODUCTS AND SERVICES (U.S. CLS. 100, 101 AND 102).

STEVEN R. FINE, EXAMINING ATTORNEY

CLASS 35—(Continued).

TIONAL FACILITIES; CONSULTING SERVICES IN THE FIELD OF ENERGY USAGE MANAGEMENT AND ENERGY EFFICIENCY; CONSULTING SERVICES IN THE FIELDS OF ENERGY CONSUMPTION AND USAGE CONSERVATION TO IMPROVE ENERGY EFFICIENCY; ENERGY AUDITING; ENERGY MANAGEMENT SERVICES, NAMELY, PROVIDING A SERVICE THAT ALLOWS CUSTOMERS TO PURCHASE ENERGY FROM VARIOUS ENERGY PROVIDERS; ENERGY MANAGEMENT SERVICES, NAMELY, PROVIDING A SERVICE THAT ALLOWS CUSTOMERS TO PURCHASE ENERGY, NAMELY, ELECTRICITY, NATURAL GAS AND RENEWABLE ENERGY, AT A FIXED PRICE; ENERGY USAGE MANAGEMENT; ENERGY USAGE MANAGEMENT INFORMATION SERVICES; GOVERNMENT RELATIONS CONSULTANCY SERVICES; HOME ENERGY ASSESSMENT SERVICES FOR THE PURPOSE OF DETERMINING ENERGY EFFICIENCY OR USAGE MANAGEMENT; INFORMATION IN THE FIELD OF ENERGY EFFICIENCY; PROCUREMENT SERVICES, NAMELY, PROCUREMENT OF CONTRACTS FOR OTHERS FOR THE PURCHASE OF ENERGY; PROMOTING THE BENEFITS OF ENERGY EFFICIENT LIGHTING TECHNOLOGIES TO PROFESSIONALS IN THE LIGHTING FIELD; PROMOTING THE ENERGY EFFICIENT PRODUCTS AND SERVICES OF OTHERS; PROMOTING THE INTERESTS OF PEOPLE CONCERNED WITH HEALTH, COMMUNITY AND ENVIRONMENTAL SUSTAINABILITY ISSUES; PROVIDING A WEB-BASED ON-LINE PORTAL THAT PROVIDES CUSTOMER ACCESS TO THEIR ELECTRIC BILL ACCOUNT INFORMATION, ENERGY USAGE PATTERN INFORMATION, AND ENERGY CONSUMPTION AND USAGE DATA, FOR PURPOSES OF UTILITY ACCOUNT BUSINESS MANAGEMENT AND ENERGY USAGE MANAGEMENT; PROVISION OF INFORMATION, ADVICE AND CONSULTANCY IN RELATION TO ENERGY EFFICIENCY; PUBLIC POLICY CONSULTANCY SERVICES (U.S. CLS. 100, 101 AND 102).

FIRST USE 9-22-2005; IN COMMERCE 4-20-2009.

KATINA MISTER, EXAMINING ATTORNEY

SN 85-421,023. CARBON CROSS DEVELOPMENT LLC,
WASHINGTON, DC, DC. FILED 9-13-2011.

Carbon Cross

THE MARK CONSISTS OF STANDARD CHARACTERS WITHOUT CLAIM TO ANY PARTICULAR FONT, STYLE, SIZE, OR COLOR.

NO CLAIM IS MADE TO THE EXCLUSIVE RIGHT TO USE "CARBON", APART FROM THE MARK AS SHOWN.

FOR BUSINESS CONSULTANCY; BUSINESS CONSULTATION; BUSINESS CONSULTING AND ADVISORY SERVICES IN THE FIELD OF ENERGY EFFICIENCY; BUSINESS CONSULTING SERVICES FOR THE ELECTRIC ENERGY INDUSTRY; BUSINESS CONSULTING SERVICES IN THE FIELD OF SUSTAINABLE NEIGHBORHOOD DEVELOPMENT.; BUSINESS CONSULTING SERVICES IN THE FIELDS OF ENERGY MEASUREMENT TO IMPROVE ENERGY EFFICIENCY WITHIN RESIDENTIAL, COMMERCIAL, INDUSTRIAL AND INSTITUTIONAL FACILITIES; CONDUCTING ENERGY AUDITS OF COMMERCIAL AND INSTITUTIONAL FACILITIES FOR THE PURPOSE OF IMPROVING ENERGY EFFICIENCY; CONSULTATION IN THE FIELD OF ENERGY EFFICIENCY; CONSULTING SERVICES IN THE AREA OF SUSTAINABLE BUSINESS SOLUTIONS; CONSULTING SERVICES IN THE FIELD OF ENERGY EFFICIENCY FOR COMMERCIAL AND INSTITU-

SN 85-421,065. MEDAILLE COLLEGE, BUFFALO, NY.
FILED 9-13-2011.

DONATE YOUR BRAIN

THE MARK CONSISTS OF STANDARD CHARACTERS WITHOUT CLAIM TO ANY PARTICULAR FONT, STYLE, SIZE, OR COLOR.

FOR CHARITABLE SERVICES, NAMELY, THE COORDINATION, ORGANIZATION AND CONDUCTING OF VOLUNTEER TRADE FAIRS FOR BUSINESS AND PROMOTIONAL PURPOSES; PROVIDING INFORMATION IN THE FIELD OF INTELLECTUAL VOLUNTEERISM AND CHARITABLE OPPORTUNITIES, NAMELY, PROVIDING INFORMATION IN THE FIELD OF CHARITABLE SERVICES IN THE NATURE OF AVAILABLE VOLUNTEER OPPORTUNITIES IN VOLUNTEER AND CHARITABLE PROGRAMS (U.S. CLS. 100, 101 AND 102).

FIRST USE 10-8-2009; IN COMMERCE 10-8-2009.

KATHERINE E. HALMEN, EXAMINING ATTORNEY

CLASS 35—(Continued).

SN 85-421,639. DMI LLC, MINNEAPOLIS, MN. FILED 9-13-2011.



NO CLAIM IS MADE TO THE EXCLUSIVE RIGHT TO USE "UNIFIED DATA", APART FROM THE MARK AS SHOWN.

THE MARK CONSISTS OF THE LETTERS "B" AND "D" CONNECTED BY AN EXAGGERATED "U": THE WORDS "BRIDGZ UNIFIED" DATA BELOW THE WORD "BUD"; ALL INCASED IN A BADGE DESIGN.

FOR ADVERTISING AND MARKETING SERVICES (U.S. CLS. 100, 101 AND 102).

ERNEST SHOSHO, EXAMINING ATTORNEY

CLASS 35—(Continued).

SN 85-422,662. ALLY FINANCIAL INC., DETROIT, MI. FILED 9-14-2011.



OWNER OF U.S. REG. NOS. 3,667,813, 3,722,309 AND OTHERS.

NO CLAIM IS MADE TO THE EXCLUSIVE RIGHT TO USE "AUTO REMARKETING", APART FROM THE MARK AS SHOWN.

THE MARK CONSISTS OF THE WORDS "ALLY" IN LOWERCASE LETTERS IN A SLIGHTLY LARGER FONT THAN THE WORD "AUTO" WHICH IS IN ALL UPPERCASE LETTERS, BOTH WORDS PLACED ABOVE A LINE WITH THE WORD "REMARKETING" WRITTEN IN ALL UPPERCASE LETTERS APPEARING BELOW THAT SAME LINE.

FOR ARRANGING AND CONDUCTING AUTOMOBILE AUCTIONS; PROVIDING ON-LINE AUTOMOBILE AUCTIONS (U.S. CLS. 100, 101 AND 102).

FIRST USE 2-14-2011; IN COMMERCE 2-14-2011.

MICHAEL LITZAU, EXAMINING ATTORNEY

SN 85-422,097. ALLY FINANCIAL INC., DETROIT, MI. FILED 9-14-2011.

ALLY AUTO REMARKETING

THE MARK CONSISTS OF STANDARD CHARACTERS WITHOUT CLAIM TO ANY PARTICULAR FONT, STYLE, SIZE, OR COLOR.

OWNER OF U.S. REG. NOS. 3,667,813, 3,722,309 AND OTHERS.

NO CLAIM IS MADE TO THE EXCLUSIVE RIGHT TO USE "AUTO REMARKETING", APART FROM THE MARK AS SHOWN.

FOR ARRANGING AND CONDUCTING AUTOMOBILE AUCTIONS; PROVIDING ON-LINE AUTOMOBILE AUCTIONS (U.S. CLS. 100, 101 AND 102).

FIRST USE 2-14-2011; IN COMMERCE 2-14-2011.

MICHAEL LITZAU, EXAMINING ATTORNEY

SN 85-423,323. CAROLYN S. MOSHIER, DBA K.C. ESTATE SALES, WICHITA, KS. FILED 9-15-2011.

K.C. Estate Sales

THE MARK CONSISTS OF STANDARD CHARACTERS WITHOUT CLAIM TO ANY PARTICULAR FONT, STYLE, SIZE, OR COLOR.

NO CLAIM IS MADE TO THE EXCLUSIVE RIGHT TO USE "ESTATE SALES", APART FROM THE MARK AS SHOWN.

FOR ARRANGING, PLANNING, AND CONDUCTING TAG SALES, ESTATE LIQUIDATION SALES, YARD SALES OR GARAGE SALES FOR OTHERS (U.S. CLS. 100, 101 AND 102).

FIRST USE 6-1-1985; IN COMMERCE 6-1-1985.

DANNEAN HETZEL, EXAMINING ATTORNEY

CLASS 35—(Continued).

SN 85-423,329. BECCA'S BARKERY, INC., CABOOL, MO.
FILED 9-15-2011.

Becca's Barkery

THE MARK CONSISTS OF STANDARD CHARACTERS WITHOUT CLAIM TO ANY PARTICULAR FONT, STYLE, SIZE, OR COLOR.

THE NAME(S), PORTRAIT(S), AND/OR SIGNATURE(S) SHOWN IN THE MARK IDENTIFIES REBECA ESSENBURG KALCH, WHOSE CONSENT(S) TO REGISTER IS MADE OF RECORD.

FOR WHOLESALE AND RETAIL STORE SERVICES AND ON-LINE RETAIL AND WHOLESALE STORE SERVICES FEATURING PET PRODUCTS, PET FOOD AND PET TREATS (U.S. CLS. 100, 101 AND 102).

FIRST USE 2-2-2006; IN COMMERCE 2-2-2006.
CHRIS WELLS, EXAMINING ATTORNEY

SN 85-423,559. ORKAT, LLC, WESTWOOD, MA. FILED 9-15-2011.



OWNER OF U.S. REG. NOS. 1,802,380 AND 1,912,000.
NO CLAIM IS MADE TO THE EXCLUSIVE RIGHT TO USE "FASHION & SHOE WAREHOUSE", APART FROM THE MARK AS SHOWN.

THE MARK CONSISTS OF THE WORDS "FRUGAL FANNIE'S" INSIDE THE IMAGE OF A BUILDING WITH THE WORDS "FASHION & SHOE WAREHOUSE" APPEARING UNDERNEATH THE IMAGE.

FOR RETAIL CLOTHING STORE SERVICES (U.S. CLS. 100, 101 AND 102).

FIRST USE 8-31-2009; IN COMMERCE 8-31-2009.
JOHN DALIER, EXAMINING ATTORNEY

CLASS 35—(Continued).

SN 85-424,323. FRANTZ E LEON, PEMBROKE PINES, FL.
FILED 9-16-2011.

Hate is the new love

THE MARK CONSISTS OF STANDARD CHARACTERS WITHOUT CLAIM TO ANY PARTICULAR FONT, STYLE, SIZE, OR COLOR.

FOR ADVERTISING AND MARKETING SERVICES, NAMELY, PROMOTING THE GOODS AND SERVICES OF OTHERS; ADVERTISING AND PROMOTING THE GOODS AND SERVICES OF A VISUAL ARTIST; ADVERTISING SERVICES, NAMELY, PROMOTING AND MARKETING THE GOODS AND SERVICES OF OTHERS THROUGH ALL PUBLIC COMMUNICATION MEANS; ADVERTISING SERVICES, NAMELY, PROMOTING THE BRANDS, GOODS AND SERVICES OF OTHERS; ADVERTISING, MARKETING AND PROMOTION SERVICES; ADVERTISING, PROMOTION AND MARKETING SERVICES IN THE NATURE OF E-MAIL BLAST CAMPAIGNS FOR OTHERS; ARRANGING AND CONDUCTING MARKETING PROMOTIONAL EVENTS FOR OTHERS; CUSTOMER LOYALTY SERVICES AND CUSTOMER CLUB SERVICES, FOR COMMERCIAL, PROMOTIONAL AND/OR ADVERTISING PURPOSES; DEVELOPING PROMOTIONAL CAMPAIGNS FOR BUSINESS; ENTERTAINMENT MARKETING SERVICES, NAMELY, MARKETING, PROMOTION AND ADVERTISING FOR RECORDING AND PERFORMING ARTISTS; EVENT PLANNING AND MANAGEMENT FOR MARKETING, BRANDING, PROMOTING OR ADVERTISING THE GOODS AND SERVICES OF OTHERS; MARKETING AND CONSULTING SERVICES IN THE FIELD OF PROMOTING AND TRACKING THE GOODS, SERVICES, AND BRANDS OF OTHERS THROUGH ALL PUBLIC COMMUNICATION MEANS; ON-LINE PROMOTION OF COMPUTER NETWORKS AND WEBSITES; ONLINE ADVERTISING AND PROMOTIONAL SERVICES; POLITICAL PARTY SERVICES, NAMELY, PROMOTING THE INTERESTS OF A POLITICAL ORGANIZATION; PROMOTING THE GOODS AND SERVICES OF OTHERS BY PROVIDING AN INTERACTIVE WEBSITE WHERE USERS CAN INCREASE THE CURRENT VALUE OF AN ONLINE DISCOUNT BEING OFFERED BY PURCHASING THE GOODS AND SERVICES ASSOCIATED WITH THAT DISCOUNT IN THE FORM OF AN ONLINE COUPON, VOUCHER OR GIFT CARD; PROMOTING THE GOODS AND SERVICES OF OTHERS BY PROVIDING HYPERTEXT LINKS TO THE WEB SITES OF OTHERS (U.S. CLS. 100, 101 AND 102).

HAI-LY LAM, EXAMINING ATTORNEY

SN 85-425,484. J.T. FENN, NOVATO, CA. FILED 9-18-2011.

BEERCRAFT

THE MARK CONSISTS OF STANDARD CHARACTERS WITHOUT CLAIM TO ANY PARTICULAR FONT, STYLE, SIZE, OR COLOR.

FOR RETAIL STORE AND ON-LINE RETAIL STORE SERVICES FEATURING ALCOHOLIC BEVERAGES AND GENERAL CONSUMER GOODS (U.S. CLS. 100, 101 AND 102).

DAWN HAN, EXAMINING ATTORNEY

CLASS 35—(Continued).

SN 85-425,719. LINKABLE NETWORKS, INC., BOSTON, MA. FILED 9-19-2011.

LINKABLE NETWORKS

THE MARK CONSISTS OF STANDARD CHARACTERS WITHOUT CLAIM TO ANY PARTICULAR FONT, STYLE, SIZE, OR COLOR.

NO CLAIM IS MADE TO THE EXCLUSIVE RIGHT TO USE "NETWORKS", APART FROM THE MARK AS SHOWN.

FOR ADVERTISING AND MARKETING (U.S. CLS. 100, 101 AND 102).

JANICE KIM, EXAMINING ATTORNEY

SN 85-425,723. GREGORY, DAWN, ATLANTA, GA. FILED 9-19-2011.

Synergizing Your Customer Experience

THE MARK CONSISTS OF STANDARD CHARACTERS WITHOUT CLAIM TO ANY PARTICULAR FONT, STYLE, SIZE, OR COLOR.

FOR BUSINESS MANAGEMENT AND CONSULTING; BUSINESS CONSULTING AS IT RELATES TO CUSTOMER EXPERIENCE; BUSINESS CONSULTING AS IT RELATES TO PERFORMANCE MANAGEMENT; BUSINESS CONSULTING AS IT RELATES TO CUSTOMER SERVICE; CUSTOMER RELATIONSHIP MANAGEMENT AND BUSINESS CONSULTING RELATING THERETO (U.S. CLS. 100, 101 AND 102).

ELI HELLMAN, EXAMINING ATTORNEY

CLASS 35—(Continued).

SN 85-426,970. COTTERWEB ENTERPRISES, INC., MENDOTA HEIGHTS, MN. FILED 9-20-2011.

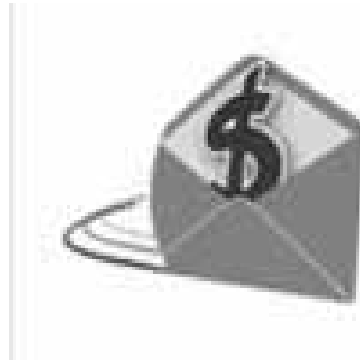

THE MARK CONSISTS OF A STYLIZED DESIGN FEATURING AN ENVELOPE WITH A DOLLAR SIGN SYMBOL, AND LINES DEPICTING SPEED OR PROPULSION TO THE LEFT.

FOR ONLINE CONSUMER LOYALTY SERVICES FOR MARKETING PURPOSES, NAMELY, PROVIDING INCENTIVE REWARD PROGRAMS TO PROMOTE CONSUMERS READING EMAIL ADVERTISING MESSAGES, COMPLETING ONLINE MARKET RESEARCH SURVEYS, CONDUCTING ONLINE SHOPPING AND PLAYING ONLINE GAMES (U.S. CLS. 100, 101 AND 102).

KELLY CHOE, EXAMINING ATTORNEY

SN 85-427,020. NIEHOFF, BLAKE J., AKA TAG SPORTS, WESLEY CHAPEL, FL. FILED 9-20-2011.

Uncork for a Cause

THE MARK CONSISTS OF STANDARD CHARACTERS WITHOUT CLAIM TO ANY PARTICULAR FONT, STYLE, SIZE, OR COLOR.

FOR EVENT PLANNING AND MANAGEMENT FOR MARKETING, BRANDING, PROMOTING OR ADVERTISING THE GOODS AND SERVICES OF OTHERS (U.S. CLS. 100, 101 AND 102).

FIRST USE 6-1-2007; IN COMMERCE 6-1-2007.

HAI-LY LAM, EXAMINING ATTORNEY

CLASS 35—(Continued).

SN 85-427,812. REPUBLIC INC., OTTAWA, CANADA, FILED 9-21-2011.

BABY REPUBLIC

THE MARK CONSISTS OF STANDARD CHARACTERS WITHOUT CLAIM TO ANY PARTICULAR FONT, STYLE, SIZE, OR COLOR.

NO CLAIM IS MADE TO THE EXCLUSIVE RIGHT TO USE "BABY", APART FROM THE MARK AS SHOWN.

FOR GIFT REGISTRY SERVICES (U.S. CLS. 100, 101 AND 102).

RAMONA ORTIGA, EXAMINING ATTORNEY

SN 85-428,167. EXECUTIVE LINKS, LLC, CHARLOTTE, NC. FILED 9-21-2011.



NO CLAIM IS MADE TO THE EXCLUSIVE RIGHT TO USE "EXECUTIVE" AND "LLC", APART FROM THE MARK AS SHOWN.

THE MARK CONSISTS OF THE LITERAL ELEMENTS "EXECUTIVE LINKS, LLC" WHEREIN AN IMAGE OF A GOLFER SWINGING THAT IS STRATEGICALLY PLACED IN BETWEEN THE WORDS "EXECUTIVE" AND "LINKS", WHEREAS THE END OF THE GOLFER STICKS HAVING DOT OVER THE LETTER I IN THE WORD "EXECUTIVE" AS SHOWN IN THE MARK.

FOR BUSINESS NETWORKING SERVICES; PROVIDING BUSINESS NETWORKING OPPORTUNITIES THROUGH GOLF LESSONS AND EVENTS; ARRANGING AND CONDUCTING SPECIAL EVENTS FOR COMMERCIAL, PROMOTIONAL OR ADVERTISING PURPOSES (U.S. CLS. 100, 101 AND 102).

FIRST USE 9-22-2010; IN COMMERCE 9-22-2010.

SUSAN LESLIE DUBOIS, EXAMINING ATTORNEY

CLASS 35—(Continued).

SN 85-428,851. PRESS GANEY ASSOCIATES, INC, SOUTH BEND, IN. FILED 9-22-2011.

**PRESS GANEY STRATEGIC
PLANNING & MARKETING
PERFORMANCE SUITE**

THE MARK CONSISTS OF STANDARD CHARACTERS WITHOUT CLAIM TO ANY PARTICULAR FONT, STYLE, SIZE, OR COLOR.

OWNER OF U.S. REG. NOS. 2,228,347, 3,772,658 AND 4,021,466.

NO CLAIM IS MADE TO THE EXCLUSIVE RIGHT TO USE "STRATEGIC PLANNING & MARKETING PERFORMANCE SUITE", APART FROM THE MARK AS SHOWN.

FOR BUSINESS ANALYSIS AND MANAGEMENT CONSULTING FOR HEALTHCARE PROVIDERS AND RELATED BUSINESSES. ANALYSIS RELATING TO THE UNDERSTANDING OF PUBLIC OPINION; BUSINESS SERVICES, NAMELY, CONDUCTING PATIENT SATISFACTION SURVEYS IN THE HEALTH CARE OR MEDICAL FIELDS AND PROVIDING BUSINESS CONSULTATION FOR THE IMPROVEMENT OF PATIENT SATISFACTION; MONITORING PATIENTS' EXPERIENCE OF CARE ON A REAL-TIME BASIS IN THE FIELD OF HEALTHCARE; PROVIDING STATISTICAL DATA SOLUTION FOR THE PURPOSE OF BRAND POSITIONING AND FOCUSING MARKETING RESOURCES ON TARGETED COMMUNICATIONS (U.S. CLS. 100, 101 AND 102).

FIRST USE 10-25-2010; IN COMMERCE 10-25-2010.

AMY HELLA, EXAMINING ATTORNEY

SN 85-429,664. NUCOMPASS MOBILITY SERVICES INC., PLEASANTON, CA. FILED 9-22-2011.

NUCOMPASS MOBILITY

THE MARK CONSISTS OF STANDARD CHARACTERS WITHOUT CLAIM TO ANY PARTICULAR FONT, STYLE, SIZE, OR COLOR.

NO CLAIM IS MADE TO THE EXCLUSIVE RIGHT TO USE "MOBILITY", APART FROM THE MARK AS SHOWN.

FOR EMPLOYEE RELOCATION SERVICES (U.S. CLS. 100, 101 AND 102).

FIRST USE 2-0-2009; IN COMMERCE 2-0-2009.

LOURDES AYALA, EXAMINING ATTORNEY

CLASS 35—(Continued).

SN 85-429,855. ADVANCED BUSINESS STRATEGIES, LLC, BEAVERTON, OR. FILED 9-22-2011.

ADVANCED BUSINESS SALES &
MARKETING

THE MARK CONSISTS OF STANDARD CHARACTERS WITHOUT CLAIM TO ANY PARTICULAR FONT, STYLE, SIZE, OR COLOR.

OWNER OF U.S. REG. NOS. 2,551,340 AND 3,263,853.

NO CLAIM IS MADE TO THE EXCLUSIVE RIGHT TO USE "BUSINESS", APART FROM THE MARK AS SHOWN. SEC. 2(F).

FOR BUSINESS CONSULTATION SERVICES (U.S. CLS. 100, 101 AND 102).

FIRST USE 8-15-2006; IN COMMERCE 8-15-2006.

LEIGH CAROLINE CASE, EXAMINING ATTORNEY

CLASS 35—(Continued).

SN 85-430,948. AMERGREEN, INC., AKA AMERGREEN-COM, THOUSAND OAKS, CA. FILED 9-23-2011.

Amergreen, Inc.

THE MARK CONSISTS OF STANDARD CHARACTERS WITHOUT CLAIM TO ANY PARTICULAR FONT, STYLE, SIZE, OR COLOR.

NO CLAIM IS MADE TO THE EXCLUSIVE RIGHT TO USE "INC.", APART FROM THE MARK AS SHOWN.

FOR BUSINESS CONSULTING AND INFORMATION SERVICES; BUSINESS CONSULTING AND MANAGEMENT IN THE FIELD OF CLINICAL TRIALS, NAMELY, PROVIDING INFORMATION MANAGEMENT SERVICES; BUSINESS CONSULTING IN THE FIELD OF ENVIRONMENTAL MANAGEMENT, NAMELY, ADVISING BUSINESSES AND INDIVIDUALS ON ISSUES OF ENVIRONMENTAL IMPACT, CONSERVATION, PRESERVATION AND PROTECTION, AND ECONOMIC ANALYSIS FOR BUSINESS PURPOSES; BUSINESS CONSULTING SERVICE THAT PROVIDES TRANSFORMATIONAL STRATEGIES TO COMPANIES WISHING TO MOVE TOWARDS SUSTAINABILITY AND SOCIALLY RESPONSIBLE BUSINESS PRACTICES, PROVIDED MAINLY TO THE CONSUMER PRODUCTS INDUSTRY (U.S. CLS. 100, 101 AND 102).

FIRST USE 11-23-2004; IN COMMERCE 11-23-2004.

FRANK LATTUCA, EXAMINING ATTORNEY

SN 85-431,395. THE ALISAM GROUP, L.L.C., SAN ANTONIO, TX. FILED 9-25-2011.

Alisam Freight Management

THE MARK CONSISTS OF STANDARD CHARACTERS WITHOUT CLAIM TO ANY PARTICULAR FONT, STYLE, SIZE, OR COLOR.

NO CLAIM IS MADE TO THE EXCLUSIVE RIGHT TO USE "FREIGHT MANAGEMENT", APART FROM THE MARK AS SHOWN.

FOR ARRANGING FOR PICKUP, DELIVERY, STORAGE AND TRANSPORTATION OF DOCUMENTS, PACKAGES, FREIGHT AND PARCELS VIA GROUND AND AIR CARRIERS; BUSINESS ADMINISTRATION IN THE FIELD OF TRANSPORT AND DELIVERY; BUSINESS MANAGEMENT CONSULTANCY IN THE FIELD OF TRANSPORT AND DELIVERY; BUSINESS MANAGEMENT IN THE FIELD OF TRANSPORT AND DELIVERY; TRANSPORTATION LOGISTICS SERVICES, NAMELY, ARRANGING THE TRANSPORTATION OF GOODS FOR OTHERS; TRANSPORTATION LOGISTICS SERVICES, NAMELY, PLANNING AND SCHEDULING SHIPMENTS FOR USERS OF TRANSPORTATION SERVICES; TRANSPORTATION MANAGEMENT SERVICES, NAMELY, PLANNING AND COORDINATING TRANSPORTATION OF PEOPLE FOR OTHERS (U.S. CLS. 100, 101 AND 102).

FIRST USE 8-1-2011; IN COMMERCE 8-1-2011.

BRIAN NEVILLE, EXAMINING ATTORNEY

SN 85-430,733. CTPARTNERS EXECUTIVE SEARCH INC., CLEVELAND, OH. FILED 9-23-2011.

CTPartners iClient

THE MARK CONSISTS OF STANDARD CHARACTERS WITHOUT CLAIM TO ANY PARTICULAR FONT, STYLE, SIZE, OR COLOR.

OWNER OF U.S. REG. NO. 3,402,762.

NO CLAIM IS MADE TO THE EXCLUSIVE RIGHT TO USE "ICLIENT", APART FROM THE MARK AS SHOWN.

FOR EXECUTIVE SEARCH AND PLACEMENT SERVICES (U.S. CLS. 100, 101 AND 102).

DAVID ELTON, EXAMINING ATTORNEY

CLASS 35—(Continued).

SN 85-432,014. TUMANOV, ERNEST, ENCINO, CA. FILED 9-26-2011.



THE MARK CONSISTS OF A MAN HOLDING A TORCH FOR WELDING FROM WHICH A SPARK IS EMANATING, ALL OF WHICH EMBEDDED IN A STYLIZED LEAF/WATER DROP DESIGN AT THE TOP OF THE LOGO. THE TORCH CONTAINS A DOT IN THE MIDDLE. THE MAN IS WEARING A PROTECTIVE MASK. ABOVE THE MAN'S LEFT SHOULDER ARE THE LETTERS "EW". DIRECTLY BENEATH THIS DESIGN IS THE WORD "ECOWELDER". IN THE WORD "ECOWELDER", THE MIDDLE PRONG OF THE LETTER "E" IS DEPICTED AS A LEAF AND COMING OUT FROM THE LAST LETTER, "R", IS A FLAME OF FIRE. UNDERNEATH THE WORD "ECOWELDER" IS THE SLOGAN "INNOVATIVE SOLUTIONS IN METALWORKING."

FOR RETAIL STORE AND ON-LINE RETAIL STORE SERVICES FEATURING WELDING AND CUTTING EQUIPMENT, ACCESSORIES AND SUPPLIES FOR WELDING AND CUTTING EQUIPMENT (U.S. CLS. 100, 101 AND 102).

FIRST USE 4-1-2011; IN COMMERCE 4-1-2011.
KATHLEEN KOLACZ, EXAMINING ATTORNEY

CLASS 35—(Continued).

SN 85-432,639. MEDICAL JUSTICE SERVICES, INC., GREENSBORO, NC. FILED 9-27-2011.

MONITOR. RESPOND. PROMOTE.

THE MARK CONSISTS OF STANDARD CHARACTERS WITHOUT CLAIM TO ANY PARTICULAR FONT, STYLE, SIZE, OR COLOR.

FOR BUSINESS MARKETING CONSULTING, NAMELY, REPUTATION MANAGEMENT AND ON-LINE REPUTATION MANAGEMENT FOR DOCTORS (U.S. CLS. 100, 101 AND 102).

FIRST USE 8-0-2011; IN COMMERCE 8-0-2011.
EMILY CHUO, EXAMINING ATTORNEY

SN 85-432,859. THE CORYN GROUP II, LLC, NEWTOWN SQUARE, PA. FILED 9-27-2011.

UNLIMITED VACATION CLUB

SN 85-432,150. THE POWDER COATING INSTITUTE, INC., THE WOODLANDS, TX. FILED 9-26-2011.

POWDER COATING INSTITUTE

THE MARK CONSISTS OF STANDARD CHARACTERS WITHOUT CLAIM TO ANY PARTICULAR FONT, STYLE, SIZE, OR COLOR.

OWNER OF U.S. REG. NO. 1,617,170.
NO CLAIM IS MADE TO THE EXCLUSIVE RIGHT TO USE "INSTITUTE", APART FROM THE MARK AS SHOWN. SEC. 2(F).

FOR ASSOCIATION SERVICES, NAMELY, PROMOTING THE INTERESTS OF THE POWDER COATING INDUSTRY (U.S. CLS. 100, 101 AND 102).

FIRST USE 5-1-1981; IN COMMERCE 5-1-1981.
B. PARADEWELAI, EXAMINING ATTORNEY

THE MARK CONSISTS OF STANDARD CHARACTERS WITHOUT CLAIM TO ANY PARTICULAR FONT, STYLE, SIZE, OR COLOR.

OWNER OF U.S. REG. NO. 4,031,236.
NO CLAIM IS MADE TO THE EXCLUSIVE RIGHT TO USE "VACATION CLUB", APART FROM THE MARK AS SHOWN.

FOR ADMINISTRATION OF A CONSUMER LOYALTY PROGRAM TO PROMOTE HOTEL SERVICES OF OTHERS; MANAGEMENT OF HOTEL INCENTIVE PROGRAMS OF OTHERS; DEVELOPING AND ADMINISTERING A MEMBERSHIP REWARDS PROGRAM FOR LODGING GUESTS TO OBTAIN DISCOUNTS ON GOODS AND SERVICES; PROMOTING THE GOODS AND SERVICES OF OTHERS BY MEANS OF THE ISSUANCE OF LOYALTY REWARDS CARDS; CUSTOMER LOYALTY SERVICES AND CUSTOMER CLUB SERVICES, FOR COMMERCIAL, PROMOTIONAL AND/OR ADVERTISING PURPOSES; PROVIDING INCENTIVE AWARD PROGRAMS FOR CUSTOMERS THROUGH ISSUANCE AND PROCESSING OF LOYALTY POINTS FOR THE PURCHASE OF A COMPANY'S GOODS OR SERVICES (U.S. CLS. 100, 101 AND 102).

FIRST USE 10-1-2010; IN COMMERCE 10-1-2010.
STEVEN JACKSON, EXAMINING ATTORNEY

CLASS 35—(Continued).

SN 85-433,116. ASSOCIATED WHOLESALE GROCERS, INC., KANSAS CITY, KS. FILED 9-27-2011.



OWNER OF U.S. REG. NO. 3,110,889.
THE MARK CONSISTS OF THE STYLIZED WORDING "PRICE DROP" WITHIN AN OVAL DESIGN ELEMENT WITH A SUNBURST BACKGROUND IN THE OVAL EMANATING OUTWARDS. THE WORDING "PRICE" IS LOCATED ABOVE THE WORDING "DROP". THE LETTER "P" IN THE WORD "DROP" HAS A STYLIZED ARROW COMING OUT FROM THE UPPER RIGHT HAND SIDE THAT CURVES AND POINTS DOWNWARDS.
SEC. 2(F).

FOR RETAIL STORE SERVICES IN THE FIELD OF FOOD AND GENERAL CONSUMER MERCHANDISE (U.S. CLS. 100, 101 AND 102).

FIRST USE 8-17-2011; IN COMMERCE 8-17-2011.
NAPOLEON SHARMA, EXAMINING ATTORNEY

CLASS 35—(Continued).

SN 85-435,178. PAANCH INC, SECAUCUS, NJ. FILED 9-29-2011.



NO CLAIM IS MADE TO THE EXCLUSIVE RIGHT TO USE "WINE OUTLET", APART FROM THE MARK AS SHOWN.

THE MARK CONSISTS OF THE STYLIZED TEXT "WINE OUTLET". IN THE MIDDLE THERE IS A WINE BARREL POURING INTO THE WINE GLASS WITH A SPLASH.

FOR RETAIL STORE AND ON-LINE RETAIL STORE SERVICES FEATURING BEER, SPIRITS, AND FINE WINE (U.S. CLS. 100, 101 AND 102).

FIRST USE 11-15-2005; IN COMMERCE 11-15-2005.
ALICIA COLLINS, EXAMINING ATTORNEY

SN 85-435,780. CELLIT, LLC, CHICAGO, IL. FILED 9-29-2011.

CELLIT

SN 85-434,169. TRIAD DIGITAL MEDIA, LLC, SOUTH-FIELD, MI. FILED 9-28-2011.

DIGITAL END AISLE

THE MARK CONSISTS OF STANDARD CHARACTERS WITHOUT CLAIM TO ANY PARTICULAR FONT, STYLE, SIZE, OR COLOR.

NO CLAIM IS MADE TO THE EXCLUSIVE RIGHT TO USE "DIGITAL", APART FROM THE MARK AS SHOWN.

FOR ONLINE ADVERTISING, MARKETING AND PROMOTIONAL SERVICES (U.S. CLS. 100, 101 AND 102).
DOMINIC J. FERRAIUOLO, EXAMINING ATTORNEY

THE MARK CONSISTS OF STANDARD CHARACTERS WITHOUT CLAIM TO ANY PARTICULAR FONT, STYLE, SIZE, OR COLOR.

FOR PROMOTING AND MARKETING THE GOODS AND SERVICES OF OTHERS BY DISTRIBUTING ADVERTISING MATERIAL, COUPONS AND DISCOUNT OFFERS VIA TEXT MESSAGES; PROVIDING MARKETING CAMPAIGNS FOR OTHERS FEATURING ADVERTISING TEXT MESSAGING AND ELECTRONIC COUPONS VIA MOBILE COMMUNICATIONS; CUSTOMER RELATIONSHIP MANAGEMENT; CONDUCTING MARKETING SURVEYS; ACCOUNT AUDITING; CONSULTING IN THE FIELD OF ADVERTISING; ANALYSIS OF CUSTOMER PURCHASING HABITS AND TRENDS (U.S. CLS. 100, 101 AND 102).

FIRST USE 3-31-2005; IN COMMERCE 3-31-2005.
HOWARD B. LEVINE, EXAMINING ATTORNEY

CLASS 35—(Continued).

SN 85-435,966. TAXO, INC., ELMHURST, NY. FILED 9-30-2011.



THE COLOR(S) GREEN, GREY AND WHITE IS/ARE CLAIMED AS A FEATURE OF THE MARK.

THE MARK CONSISTS OF THE WORD "TAXO" IN GREY, WITH A GREEN CIRCLE TO THE LEFT, IN WHICH IS A WHITE CIRCLE, AND A CURVED WHITE LINE BELOW THE WHITE CIRCLE. UNDER THE "O" IN "TAXO", IS A GREEN CURVED LINE.

FOR INCOME TAX PREPARATION; TAX FILING SERVICES; TAX PREPARATION (U.S. CLS. 100, 101 AND 102).

GRETTA YAO, EXAMINING ATTORNEY

SN 85-436,162. VANDEBERG-HOLLAND, LINDA, SAN DIEGO, CA. FILED 9-30-2011.



THE COLOR(S) RED, ORANGE, YELLOW, GREEN, BLUE, PURPLE, AND PINK IS/ARE CLAIMED AS A FEATURE OF THE MARK.

THE MARK CONSISTS OF A STYLIZED HEART IN RED WITH BANDS IN THE COLORS ORANGE, YELLOW, GREEN, BLUE, AND PURPLE. THE WORDING "MAKE THE HOPE HAPPEN" APPEARS IN STACKED FORMATION TO THE RIGHT OF THE HEART IN THE COLORS PINK, ORANGE, PURPLE, AND BLUE.

FOR CONSULTATION SERVICES, NAMELY, CREATIVE AND STRATEGIC CONSULTATION REGARDING DEVELOPMENT AND PRODUCTION OF MARKETING CAMPAIGNS FOR OTHERS (U.S. CLS. 100, 101 AND 102).

YAT SYE, LEE, EXAMINING ATTORNEY

CLASS 35—(Continued).

SN 85-436,384. RODRIGUEZ, GABRIEL, DBA ORIETX, TRUJILLO ALTO, PUERTO RICO, FILED 9-30-2011.

THE COLOR(S) WHITE AND FUCHSIA IS/ARE CLAIMED AS A FEATURE OF THE MARK.

THE MARK CONSISTS OF CAPITAL LETTER "O" FOLLOWED BY LOWERCASE LETTERS "R", "I", "E", "T" FOLLOWED BY THE LETTER "X" IN UPPERCASE. ALL THE LETTERS ARE WHITE ON A RECTANGULAR FUCHSIA BACKGROUND.

FOR ON-LINE BUSINESS NETWORKING SERVICES; PROVIDING A WEBSITE FOR USERS WITH SPECIFIC INFORMED RECOMMENDATIONS OF SPECIFIC CONSUMER PRODUCTS AND SERVICES VALIDATED BY THE USERS' INPUTTED PREFERENCES AND SOCIAL NETWORK; PROVIDING INFORMATION ABOUT THE GOODS AND SERVICES OF OTHERS VIA THE GLOBAL COMPUTER NETWORK; PROVIDING INFORMATION PERTAINING TO PROCUREMENT, BUYING, SELLING AND TENDERING INFORMATION AND OPPORTUNITIES RELATING TO GOODS, SERVICES, AND CONSTRUCTION VIA COMPUTER, COMPUTER NETWORKS, TELEPHONE, THE INTERNET OR ELECTRONIC MAIL; PROVIDING RATINGS VIA A GLOBAL COMPUTER NETWORK FOR HOME PRODUCTS AND SERVICES RECOMMENDED BY CONSUMERS; PROVISION OF ADVERTISING SPACE BY ELECTRONIC MEANS AND GLOBAL INFORMATION NETWORKS; PROVISION OF BUSINESS INFORMATION VIA GLOBAL COMPUTER NETWORKS (U.S. CLS. 100, 101 AND 102).

GRETTA YAO, EXAMINING ATTORNEY

SN 85-437,861. REMICK, LLOYD ZANE, VILLANOVA, PA. FILED 10-3-2011.

Zane Management

THE MARK CONSISTS OF STANDARD CHARACTERS WITHOUT CLAIM TO ANY PARTICULAR FONT, STYLE, SIZE, OR COLOR.

NO CLAIM IS MADE TO THE EXCLUSIVE RIGHT TO USE "MANAGEMENT", APART FROM THE MARK AS SHOWN.

SEC. 2(F).

FOR BUSINESS MANAGEMENT AND BUSINESS MANAGEMENT CONSULTING SERVICES IN THE FIELDS OF SPORTS, MEDIA AND ENTERTAINMENT INCLUDING, BUT NOT LIMITED TO, MUSIC, FILM, RADIO, LITERARY, PERFORMING ARTS AND TELEVISION (U.S. CLS. 100, 101 AND 102).

FIRST USE 1-1-1978; IN COMMERCE 1-1-1978.

MAYUR VAGHANI, EXAMINING ATTORNEY

CLASS 35—(Continued).

SN 85-438,160. GLOBAL VISION HOTELS LLC, NEEDHAM, MA. FILED 10-3-2011.

GLOBAL VISION HOTELS

THE MARK CONSISTS OF STANDARD CHARACTERS WITHOUT CLAIM TO ANY PARTICULAR FONT, STYLE, SIZE, OR COLOR.

NO CLAIM IS MADE TO THE EXCLUSIVE RIGHT TO USE "HOTELS", APART FROM THE MARK AS SHOWN.

FOR HOTEL MANAGEMENT FOR OTHERS (U.S. CLS. 100, 101 AND 102).

FIRST USE 12-1-2007; IN COMMERCE 12-1-2007.

PAUL MORENO, EXAMINING ATTORNEY

SN 85-438,244. GANSEVOORT MANAGEMENT GROUP INC., BROOKLYN, NY. FILED 10-3-2011.



NO CLAIM IS MADE TO THE EXCLUSIVE RIGHT TO USE "MANAGEMENT GROUP", APART FROM THE MARK AS SHOWN.

THE COLOR(S) BLUE, WHITE, BLACK IS/ARE CLAIMED AS A FEATURE OF THE MARK.

THE MARK CONSISTS OF A BLUE SQUARE WITH A PATTERN OF WHITE TRIANGLES POINTING TO THE UPPER RIGHT HAND CORNER OF THE SQUARE. THE TERM "GANSEVOORT" APPEARS BELOW THE SQUARE IN BLACK, WITH A BLUE LINE UNDERNEATH IT. THE TERM "MANAGEMENT GROUP" APPEARS BELOW IN BLACK. THE COLORS BLACK, WHITE AND BLUE ARE CLAIMED AS FEATURES OF THE MARK.

FOR BUSINESS MANAGEMENT AND CONSULTATION IN THE FIELD OF CONSTRUCTION, SECURITY GUARD SERVICES AND FIRE GUARD SERVICES (U.S. CLS. 100, 101 AND 102).

FIRST USE 3-26-2009; IN COMMERCE 3-26-2009.

SUSAN LESLIE DUBOIS, EXAMINING ATTORNEY

CLASS 35—(Continued).

SN 85-438,299. COSTA FARMS, LLC, GOULDS, FL. FILED 10-3-2011.

O24U

THE MARK CONSISTS OF STANDARD CHARACTERS WITHOUT CLAIM TO ANY PARTICULAR FONT, STYLE, SIZE, OR COLOR.

OWNER OF U.S. REG. NOS. 3,741,766 AND 3,768,161.

FOR ADVERTISING AND PROMOTION OF RETAIL SALES OF LIVE FLOWERS AND LIVING PLANTS (U.S. CLS. 100, 101 AND 102).

RICHARD WHITE, EXAMINING ATTORNEY

SN 85-438,637. FABDEALSDAILY LLC, REDONDO BEACH, CA. FILED 10-4-2011.

END OF RETAIL

THE MARK CONSISTS OF STANDARD CHARACTERS WITHOUT CLAIM TO ANY PARTICULAR FONT, STYLE, SIZE, OR COLOR.

NO CLAIM IS MADE TO THE EXCLUSIVE RIGHT TO USE "RETAIL", APART FROM THE MARK AS SHOWN.

FOR ON-LINE RETAIL STORE SERVICES FEATURING A VARIETY OF GENERAL CONSUMER GOODS AND MERCHANDISE (U.S. CLS. 100, 101 AND 102).

ROBERT STRUCK, EXAMINING ATTORNEY

SN 85-438,913. VIU HOME, INC., CELEBRATION, FL. FILED 10-4-2011.

VIU HOME

THE MARK CONSISTS OF STANDARD CHARACTERS WITHOUT CLAIM TO ANY PARTICULAR FONT, STYLE, SIZE, OR COLOR.

NO CLAIM IS MADE TO THE EXCLUSIVE RIGHT TO USE "HOME", APART FROM THE MARK AS SHOWN.

FOR ON-LINE RETAIL STORE SERVICES FEATURING FURNITURE (U.S. CLS. 100, 101 AND 102).

FIRST USE 0-0-2010; IN COMMERCE 0-0-2010.

SCOTT BIBB, EXAMINING ATTORNEY

CLASS 35—(Continued).

SN 85-439,582. ONE CALL MOVE, LLC, MINERAL SPRINGS, NC. FILED S.R. 10-5-2011; AM. P.R. 2-8-2012.



THE COLOR(S) GREEN, BLUE AND BLACK IS/ARE CLAIMED AS A FEATURE OF THE MARK.

THE MARK CONSISTS OF THE WORD "ONE" IN BLUE, FOLLOWED BY THE WORD "CALL" IN GREEN WITH A HANDSET AND PHONE CORD FORMING THE LETTER "C" IN THE WORD "CALL", FOLLOWED BY THE WORD "MOVE" IN BLUE, FOLLOWED BY THE WORDING "ONE CALL HANDLES IT ALL!" IN BLACK.

FOR ARRANGING AND COORDINATING THE CONNECTION OF UTILITIES AND CABLE, TELEPHONE, INTERNET, HOME SECURITY AND MAINTENANCE SERVICES FOR INDIVIDUALS AND BUSINESSES MOVING TO A NEW LOCATION OR RESIDENCE (U.S. CLS. 100, 101 AND 102).

FIRST USE 1-3-2011; IN COMMERCE 1-4-2011.
EDWARD FENNESSY, EXAMINING ATTORNEY

SN 85-440,623. DANIEL J. ZEHNDER, NEW BERLIN, WI. FILED 10-6-2011.

THE BOLT BARN

THE MARK CONSISTS OF STANDARD CHARACTERS WITHOUT CLAIM TO ANY PARTICULAR FONT, STYLE, SIZE, OR COLOR.

NO CLAIM IS MADE TO THE EXCLUSIVE RIGHT TO USE "BOLT", APART FROM THE MARK AS SHOWN.

FOR RETAIL, WHOLESALE AND ONLINE STORE SERVICES FEATURING FASTENERS AND RELATED PARTS FOR USE IN THE FARM AND AGRICULTURE INDUSTRY (U.S. CLS. 100, 101 AND 102).

KRISTIN DAHLING, EXAMINING ATTORNEY

SN 85-440,792. BRAMMO, INC., ASHLAND, OR. FILED 10-6-2011.

BRAMMOPARX

THE MARK CONSISTS OF STANDARD CHARACTERS WITHOUT CLAIM TO ANY PARTICULAR FONT, STYLE, SIZE, OR COLOR.

OWNER OF U.S. REG. NO. 3,831,681.

FOR FRANCHISE SERVICES, NAMELY, OFFERING BUSINESS MANAGEMENT ASSISTANCE IN THE ESTABLISHMENT AND OPERATION OF MOTORCYCLE PARKS THAT PROVIDE VEHICLE RENTAL SERVICES AND FACILITIES FOR MOTORCYCLING (U.S. CLS. 100, 101 AND 102).

HELENE LIWINSKI, EXAMINING ATTORNEY

CLASS 35—(Continued).

SN 85-441,447. CREATIVE PRODUCT SOURCING, INC., SANTA MONICA, CA. FILED 10-6-2011.

MODERN BASICS

THE MARK CONSISTS OF STANDARD CHARACTERS WITHOUT CLAIM TO ANY PARTICULAR FONT, STYLE, SIZE, OR COLOR.

NO CLAIM IS MADE TO THE EXCLUSIVE RIGHT TO USE "MODERN", APART FROM THE MARK AS SHOWN.

FOR ON-LINE RETAIL STORE SERVICES FEATURING A WIDE VARIETY OF CONSUMER GOODS OF OTHERS; ON-LINE RETAIL STORE SERVICES FEATURING KITCHEN ITEMS, ELECTRONIC GADGETS, HOME DECOR ITEMS, BAGS AND POUCHES; OPERATING AN ON-LINE SHOPPING SITE IN THE FIELD OF KITCHEN ITEMS, ELECTRONIC GADGETS, HOME DECOR ITEMS, BAGS AND POUCHES; RETAIL SHOPS FEATURING KITCHEN ITEMS, ELECTRONIC GADGETS, HOME DECOR ITEMS, BAGS AND POUCHES; RETAIL STORE SERVICES FEATURING A WIDE VARIETY OF CONSUMER GOODS OF OTHERS; RETAIL STORES FEATURING KITCHEN ITEMS, ELECTRONIC GADGETS, HOME DECOR ITEMS, BAGS AND POUCHES (U.S. CLS. 100, 101 AND 102).

DARRYL SPRUILL, EXAMINING ATTORNEY

SN 85-441,506. BLUE PETYL LLC, SAN DIEGO, CA. FILED 10-6-2011.

Blue Petyl

THE MARK CONSISTS OF STANDARD CHARACTERS WITHOUT CLAIM TO ANY PARTICULAR FONT, STYLE, SIZE, OR COLOR.

FOR ON-LINE RETAIL STORE SERVICES FEATURING ARTIFICIAL FLORAL ARRANGEMENTS AND ARRANGEMENTS MADE FROM BUTTONS AND BROOCHES (U.S. CLS. 100, 101 AND 102).

FIRST USE 2-28-2011; IN COMMERCE 2-28-2011.

MARY BOAGNI, EXAMINING ATTORNEY

CLASS 35—(Continued).

SN 85-442,567. QUAKE EQUIP LLC, HAWTHORNE, CA. FILED 10-7-2011.



NO CLAIM IS MADE TO THE EXCLUSIVE RIGHT TO USE "QUAKE", APART FROM THE MARK AS SHOWN. THE MARK CONSISTS OF A SQUARE HOUSE WITH AN OPEN DOOR AND CHIMNEY ON A CLASSIC TRIANGULAR ROOF, WITH EXPANDING CIRCLES ENCOMPASSING THE HOUSE. THE TEXTS "QUAKE EQUIP" AND "QUAKE EQUIP" FINALLY ENCLOSES THE HOME AND EXPANDING CIRCLES, SEPARATED BY TWO DASHES. FOR RETAIL STORE AND ON-LINE RETAIL STORE SERVICES FEATURING EARTHQUAKE KITS AND EMERGENCY SURVIVAL SUPPLIES (U.S. CLS. 100, 101 AND 102). FIRST USE 8-30-2010; IN COMMERCE 10-19-2010. MICHAEL WIENER, EXAMINING ATTORNEY

SN 85-442,591. JAILHOUSE JAVA LLC, ROSEMOUNT, MN. FILED 10-7-2011.



NO CLAIM IS MADE TO THE EXCLUSIVE RIGHT TO USE "JAVA", APART FROM THE MARK AS SHOWN. THE COLOR(S) RED, BLUE, LIGHT SLATE BLUE, LIGHT GRAY AND DARK GRAY IS/ARE CLAIMED AS A FEATURE OF THE MARK. THE MARK CONSISTS OF AN IMAGE OF A RED COFFEE CUP BEHIND A ROW OF BARS AS IF IN A JAIL CELL. THERE ARE CURVED RED LINES EMERGING

CLASS 35—(Continued).

FROM THE TOP OF THE CUP. THE BARS OF THE JAIL CELL ARE OUTLINED IN DARK GRAY AND COLORED IN WITH LIGHT GRAY. THE BACKGROUND OF THE CELL BEHIND THE COFFEE CUP IS STYLIZED TO LOOK LIKE BRICK, WITH BLUE OUTLINING THE BRICKS AND LIGHT SLATE BLUE AS THE INTERIOR OF THE BRICKS. ABOVE THE ROW OF BARS IS THE STYLIZED TEXT "JAILHOUSE JAVA" IN RED, AND BELOW THE BARS IS THE STYLIZED TEXT "DON'T BE A PRISONER TO BAD TASTE!" IN RED. FOR ON-LINE RETAIL STORE SERVICES FEATURING COFFEE AND COFFEE BREWING AND DRINKING RELATED ACCESSORIES (U.S. CLS. 100, 101 AND 102). FIRST USE 5-1-2010; IN COMMERCE 8-31-2010. DOUGLAS LEE, EXAMINING ATTORNEY

SN 85-442,693. VANITY CHIC BOUTIQUE, BRONX, NY. FILED 10-7-2011.



NO CLAIM IS MADE TO THE EXCLUSIVE RIGHT TO USE "BOUTIQUE", APART FROM THE MARK AS SHOWN. THE MARK CONSISTS OF A STYLIZED DESIGN OF AN ANTIQUE FRAME WITH SWIRLY/SCROLL WORK, A BOW HANGING FROM THE TOP AND THE LETTERS "VC" AND THE TEXT "VANITY CHIC BOUTIQUE" UNDER IT. FOR RETAIL STORE SERVICES FEATURING FASHION JEWELRY, HANDBAGS, VINTAGE CLOTHING, SHOES, CLOTHING ITEMS, AND JEWELRY ACCESSORIES (U.S. CLS. 100, 101 AND 102). MARK SPARACINO, EXAMINING ATTORNEY

SN 85-443,314. CADABRA LLC, REDMOND, WA. FILED 10-10-2011.

CAMPUSWALL

THE MARK CONSISTS OF STANDARD CHARACTERS WITHOUT CLAIM TO ANY PARTICULAR FONT, STYLE, SIZE, OR COLOR. FOR CLASSIFIED ADVERTISING FOR COLLEGE STUDENTS, STAFF AND OTHERS VIA ELECTRONIC MEDIA, INCLUDING THE INTERNET (U.S. CLS. 100, 101 AND 102). ELLEN PERKINS, EXAMINING ATTORNEY

CLASS 35—(Continued).

SN 85-444,404. PLATINUM MANAGEMENT LLC, DBA PLATINUM GROUP, EDEN PRAIRIE, MN. FILED 10-11-2011.

Meaningful Capitalism

THE MARK CONSISTS OF STANDARD CHARACTERS WITHOUT CLAIM TO ANY PARTICULAR FONT, STYLE, SIZE, OR COLOR.

NO CLAIM IS MADE TO THE EXCLUSIVE RIGHT TO USE "CAPITALISM", APART FROM THE MARK AS SHOWN.

FOR ADVISORY SERVICES RELATING TO BUSINESS MANAGEMENT AND BUSINESS OPERATIONS; ASSISTANCE IN MANAGEMENT OF BUSINESS ACTIVITIES; ASSISTANCE WITH BUSINESS MANAGEMENT AND PLANNING; BUSINESS ADVICE, INQUIRIES OR INFORMATION; BUSINESS ADVISORY SERVICES, CONSULTANCY AND INFORMATION; BUSINESS APPRAISAL CONSULTATION; BUSINESS CONSULTATION; BUSINESS CONSULTING, INQUIRIES OR INFORMATION; BUSINESS CONSULTING, MANAGEMENT, PLANNING AND SUPERVISION; BUSINESS DEVELOPMENT SERVICES; BUSINESS MANAGEMENT ADVICE; BUSINESS MANAGEMENT AND ADVICE; BUSINESS MANAGEMENT CONSULTANCY AND ADVISORY SERVICES; BUSINESS MANAGEMENT CONSULTANCY SERVICES; BUSINESS MANAGEMENT CONSULTATION; BUSINESS MANAGEMENT CONSULTING AND ADVISORY SERVICES (U.S. CLS. 100, 101 AND 102).

FIRST USE 10-3-2008; IN COMMERCE 10-3-2008.
ANDREA BUTLER, EXAMINING ATTORNEY

SN 85-444,469. THE SLEEP TRAIN, INC., ROCKLIN, CA. FILED 10-11-2011.

SLEEP TRAIN MATTRESS CENTER

THE MARK CONSISTS OF STANDARD CHARACTERS WITHOUT CLAIM TO ANY PARTICULAR FONT, STYLE, SIZE, OR COLOR.

OWNER OF U.S. REG. NOS. 1,714,531, 1,715,817 AND 2,924,879.

NO CLAIM IS MADE TO THE EXCLUSIVE RIGHT TO USE "SLEEP" AND "MATTRESS CENTER", APART FROM THE MARK AS SHOWN.

FOR RETAIL FURNITURE STORES (U.S. CLS. 100, 101 AND 102).

FIRST USE 0-0-1992; IN COMMERCE 0-0-1992.
NAAKWAMA ANKRAH, EXAMINING ATTORNEY

CLASS 35—(Continued).

SN 85-444,668. MJCM, LLC, DBA PINNACLE FINANCIAL STRATEGIES, HOUSTON, TX. FILED 10-11-2011.

CASH COUNTS

THE MARK CONSISTS OF STANDARD CHARACTERS WITHOUT CLAIM TO ANY PARTICULAR FONT, STYLE, SIZE, OR COLOR.

NO CLAIM IS MADE TO THE EXCLUSIVE RIGHT TO USE "CASH", APART FROM THE MARK AS SHOWN.

FOR BUSINESS CONSULTATION SERVICES; BUSINESS MARKETING CONSULTING SERVICES; BUSINESS MARKETING SERVICES; PROMOTION AND MARKETING SERVICES AND RELATED CONSULTING (U.S. CLS. 100, 101 AND 102).

DARRYL SPRUILL, EXAMINING ATTORNEY

SN 85-444,677. MJCM, LLC, DBA PINNACLE FINANCIAL STRATEGIES, HOUSTON, TX. FILED 10-11-2011.

BUSINESS COUNTS

THE MARK CONSISTS OF STANDARD CHARACTERS WITHOUT CLAIM TO ANY PARTICULAR FONT, STYLE, SIZE, OR COLOR.

NO CLAIM IS MADE TO THE EXCLUSIVE RIGHT TO USE "BUSINESS", APART FROM THE MARK AS SHOWN.

FOR BUSINESS CONSULTATION SERVICES; BUSINESS MARKETING CONSULTING SERVICES; BUSINESS MARKETING SERVICES; PROMOTION AND MARKETING SERVICES AND RELATED CONSULTING (U.S. CLS. 100, 101 AND 102).

DARRYL SPRUILL, EXAMINING ATTORNEY

SN 85-444,867. KMS CONCEPTS, LLC, BOTHELL, WA. FILED 10-11-2011.

CREATIVE CYCLE CONCEPTS

THE MARK CONSISTS OF STANDARD CHARACTERS WITHOUT CLAIM TO ANY PARTICULAR FONT, STYLE, SIZE, OR COLOR.

NO CLAIM IS MADE TO THE EXCLUSIVE RIGHT TO USE "CYCLE", APART FROM THE MARK AS SHOWN.

FOR RETAIL STORE SERVICES AND ONLINE RETAIL STORE SERVICES IN THE FIELD OF MOTORCYCLE PARTS AND ACCESSORIES (U.S. CLS. 100, 101 AND 102).

FIRST USE 12-17-2003; IN COMMERCE 12-17-2003.
MARIA-VICTORIA SUAREZ, EXAMINING ATTORNEY

CLASS 35—(Continued).

SN 85-445,134. ELECTRIDUCT, INC., FORT LAUDERDALE, FL. FILED 10-12-2011.

ELECTRIDUCT

THE MARK CONSISTS OF STANDARD CHARACTERS WITHOUT CLAIM TO ANY PARTICULAR FONT, STYLE, SIZE, OR COLOR.

FOR ON-LINE RETAIL STORE SERVICES FEATURING ACCESSORIES FOR WIRES AND CABLES, NAMELY, CORD PROTECTORS, CONNECTORS, BRAIDED SLEEVING, CABLE COVERS, AND EXTENSION CORDS (U.S. CLS. 100, 101 AND 102).

FIRST USE 7-28-1955; IN COMMERCE 7-28-1955.
HEATHER BIDDULPH, EXAMINING ATTORNEY

SN 85-445,242. THE GRACE TRUST, INC., WINONA LAKE, IN. FILED 10-12-2011.

ENCOMPASS WORLD PARTNERS

THE MARK CONSISTS OF STANDARD CHARACTERS WITHOUT CLAIM TO ANY PARTICULAR FONT, STYLE, SIZE, OR COLOR.

FOR PROMOTING PUBLIC AWARENESS OF THE NEED FOR AND IMPORTANCE OF MISSIONARY WORK; PROMOTING THE MISSIONARY WORK OF OTHERS, NAMELY, PROVIDING INFORMATION ABOUT MISSIONS FOR THE PURPOSE OF ENCOURAGING OTHERS TO DO MISSIONARY WORK, TO MAKE DONATIONS TO MISSIONARY WORK, AND TO PRAY FOR INDIVIDUALS CONDUCTING MISSIONARY WORK (U.S. CLS. 100, 101 AND 102).

LEIGH CAROLINE CASE, EXAMINING ATTORNEY

SN 85-445,256. INSTRUMENTAL SERVICES INC, HOBOKEN, NJ. FILED 10-12-2011.

InRhythm

THE MARK CONSISTS OF STANDARD CHARACTERS WITHOUT CLAIM TO ANY PARTICULAR FONT, STYLE, SIZE, OR COLOR.

FOR BUSINESS MODELING CONSULTING SERVICES, NAMELY, BUSINESS PLANNING; OPEN MARKET STRATEGY CONSULTING SERVICES, NAMELY, CONSULTING SERVICES IN THE FIELDS OF MARKET ANALYSIS; MARKETING CONSULTING; BUSINESS CONSULTING AND INFORMATION SERVICES; BUSINESS STRATEGY DEVELOPMENT SERVICES IN THE FIELD OF NEW PRODUCTS (U.S. CLS. 100, 101 AND 102).

FIRST USE 6-11-2002; IN COMMERCE 6-11-2002.
DAVID MURRAY, EXAMINING ATTORNEY

CLASS 35—(Continued).

SN 85-445,258. COUTURE CLUB LLC, UNION, NJ. FILED 10-12-2011.



THE
coutureclub
ACCESS TO LUXURY

NO CLAIM IS MADE TO THE EXCLUSIVE RIGHT TO USE "COUTURE CLUB", APART FROM THE MARK AS SHOWN.

THE MARK CONSISTS OF A KEY LOCK DESIGN WITH THE TEXT "THE COUTURECLUB ACCESS TO LUXURY" BELOW IT IN A STACKED FORMATION.

FOR ON-LINE RETAIL STORE SERVICES FEATURING HANDBAGS, SUNGLASSES, AND WATCHES (U.S. CLS. 100, 101 AND 102).

SEAN CROWLEY, EXAMINING ATTORNEY

SN 85-445,302. TAXSHOT CORPORATION, BISCAYNE PARK, FL. FILED 10-12-2011.

Taxshot

THE MARK CONSISTS OF STANDARD CHARACTERS WITHOUT CLAIM TO ANY PARTICULAR FONT, STYLE, SIZE, OR COLOR.

FOR INCOME TAX CONSULTATION; INCOME TAX PREPARATION; TAX ADVISORY SERVICES; TAX AND TAXATION PLANNING, ADVICE, INFORMATION AND CONSULTANCY SERVICES; TAX FILING SERVICES; TAX PREPARATION (U.S. CLS. 100, 101 AND 102).

KIMBERLY FRYE, EXAMINING ATTORNEY

SN 85-445,463. LORITO, TIMOTHY, HOLTSVILLE, NY. FILED 10-12-2011.

**We don't give a HOOT about
the competition**

THE MARK CONSISTS OF STANDARD CHARACTERS WITHOUT CLAIM TO ANY PARTICULAR FONT, STYLE, SIZE, OR COLOR.

FOR ADVERTISING AND MARKETING (U.S. CLS. 100, 101 AND 102).

LINDA ORNDORFF, EXAMINING ATTORNEY

CLASS 35—(Continued).

SN 85-445,473. LATINO CELLULAR LLC, CORAL GABLES, FL. FILED 10-12-2011.

REDMAS

THE MARK CONSISTS OF STANDARD CHARACTERS WITHOUT CLAIM TO ANY PARTICULAR FONT, STYLE, SIZE, OR COLOR.

FOR PROVIDING MOBILE ADVERTISING SERVICES; DISSEMINATION OF ADVERTISING FOR OTHERS VIA MOBILE WEBSITES, TEXT MESSAGES, APPLICATIONS, MOBILE SEARCH ENGINES AND MOBILE DEVICES; PROVIDING ONLINE ADVERTISING FOR OTHERS, NAMELY, PROVIDING ADVERTISING SPACE ON WEBSITES AND SEARCH ENGINES (U.S. CLS. 100, 101 AND 102).

CHRISIE B. KING, EXAMINING ATTORNEY

SN 85-445,495. PARLIAMENT INCORPORATED, PORTLAND, OR. FILED 10-12-2011.

PARLIAMENT

THE MARK CONSISTS OF STANDARD CHARACTERS WITHOUT CLAIM TO ANY PARTICULAR FONT, STYLE, SIZE, OR COLOR.

FOR BRAND CONCEPT AND BRAND DEVELOPMENT SERVICES FOR CORPORATE AND INDIVIDUAL CLIENTS (U.S. CLS. 100, 101 AND 102).

FIRST USE 9-1-2007; IN COMMERCE 9-1-2007.

TEJBIR SINGH, EXAMINING ATTORNEY

SN 85-445,550. FII - NATIONAL, DBA FAMILY INDEPENDENCE INITIATIVE, OAKLAND, CA. FILED 10-12-2011.

FII

THE MARK CONSISTS OF STANDARD CHARACTERS WITHOUT CLAIM TO ANY PARTICULAR FONT, STYLE, SIZE, OR COLOR.

FOR CHARITABLE SERVICES, NAMELY, ORGANIZING AND DEVELOPING PROJECTS THAT AIM TO IMPROVE THE LIVES OF UNDERPRIVILEGED AND IMPOVERISHED PEOPLE (U.S. CLS. 100, 101 AND 102).

FIRST USE 1-1-2001; IN COMMERCE 1-1-2001.

ALICE BENMAMAN, EXAMINING ATTORNEY

CLASS 35—(Continued).

SN 85-445,561. SOLAR ENERGY INDUSTRIES ASSOCIATION, WASHINGTON, DC. FILED 10-12-2011.

SOLAR WORKS FOR AMERICA

THE MARK CONSISTS OF STANDARD CHARACTERS WITHOUT CLAIM TO ANY PARTICULAR FONT, STYLE, SIZE, OR COLOR.

FOR ASSOCIATION SERVICES, NAMELY, PROMOTING THE INTERESTS OF THE SOLAR ENERGY INDUSTRY; PROMOTING PUBLIC AWARENESS OF THE NEED FOR SOLAR ENERGY; AND PROVIDING INFORMATION ABOUT SOLAR INDUSTRY JOBS (U.S. CLS. 100, 101 AND 102).

FIRST USE 9-0-2010; IN COMMERCE 9-0-2010.

JULIE VEPPUMTHARA, EXAMINING ATTORNEY

SN 85-445,622. NATIONAL ACADEMY OF PERIOPERATIVE ECHOCARDIOGRAPHY, INC., SALT LAKE CITY, UT. FILED 10-12-2011.

MEDANALYTICS

THE MARK CONSISTS OF STANDARD CHARACTERS WITHOUT CLAIM TO ANY PARTICULAR FONT, STYLE, SIZE, OR COLOR.

FOR COMPUTER DATABASE MANAGEMENT IN THE FIELD OF MEDICINE AND HEALTHCARE EDUCATION, RECORDKEEPING, TESTING AND CERTIFICATION; BUSINESS MANAGEMENT CONSULTATION AND ADVISORY SERVICES, NAMELY, BUSINESS INTELLIGENCE, BUSINESS PERFORMANCE MANAGEMENT AND BUSINESS ANALYTICS IN THE FIELD OF MEDICINE AND HEALTHCARE EDUCATION, RECORDKEEPING, TESTING AND CERTIFICATION; BUSINESS MANAGEMENT CONSULTATION, NAMELY, DEVELOPMENT OF BUSINESS ANALYTIC SYSTEMS FOR MEDICINE AND HEALTHCARE EDUCATION, RECORDKEEPING, TESTING AND CERTIFICATION; BUSINESS CONSULTATION TO THE HEALTH CARE INDUSTRY IN THE FIELDS OF THE DEVELOPMENT AND IMPLEMENTATION OF MEDICINE AND HEALTHCARE EDUCATION, RECORDKEEPING, TESTING AND CERTIFICATION POLICIES, PRACTICES, AND QUALITY ASSURANCE (U.S. CLS. 100, 101 AND 102).

DAVID I, EXAMINING ATTORNEY

CLASS 35—(Continued).

SN 85-445,746. PERFORM GROUP, LLC, YORK, PA. FILED 10-12-2011.



OWNER OF U.S. REG. NOS. 1,701,887, 1,732,114 AND 2,591,335.

THE MARK CONSISTS OF A STYLIZED "A" WITH THE WORD "AERIALS" ABOVE IT AND THE WORDS "BY ALPHA FACTOR" BELOW IT.

FOR COMPUTERIZED ON-LINE RETAIL STORE SERVICES IN THE FIELD OF APPAREL FOR GYMNASTS; MAIL ORDER CATALOG SERVICES FEATURING APPAREL FOR GYMNASTS (U.S. CLS. 100, 101 AND 102).

FIRST USE 9-19-2011; IN COMMERCE 9-19-2011.
CHRISTOPHER BUONGIORNO, EXAMINING ATTORNEY

SN 85-445,773. CONSUMER METRICS INSTITUTE, INC., LAKEWOOD, CO. FILED 10-12-2011.

ConAffs

THE MARK CONSISTS OF STANDARD CHARACTERS WITHOUT CLAIM TO ANY PARTICULAR FONT, STYLE, SIZE, OR COLOR.

FOR ECONOMIC FORECASTING AND ANALYSIS; MARKET ANALYSIS AND RESEARCH SERVICES; PROVIDING INFORMATION AND ANALYSIS IN THE FIELDS OF ECONOMICS AND BUSINESS (U.S. CLS. 100, 101 AND 102).

FIRST USE 10-12-2011; IN COMMERCE 10-12-2011.
ALICIA COLLINS, EXAMINING ATTORNEY

CLASS 35—(Continued).

SN 85-445,885. BLUE SURF MARKETING, INC, DBA BLUE-SURF, MARINA DEL REY, CA. FILED 10-12-2011.

adRinger

THE MARK CONSISTS OF STANDARD CHARACTERS WITHOUT CLAIM TO ANY PARTICULAR FONT, STYLE, SIZE, OR COLOR.

FOR BUSINESS SERVICES, NAMELY, TRACKING AND MONITORING OF CALLS FOR OTHERS IN RESPONSE TO ADVERTISING ADS (U.S. CLS. 100, 101 AND 102).

FIRST USE 10-11-2011; IN COMMERCE 10-11-2011.
STEVEN R. FINE, EXAMINING ATTORNEY

SN 85-446,210. LACONGO, LAURA M., ORCHARD PARK, NY. FILED 10-13-2011.

Bada-Bing Pet Products

THE MARK CONSISTS OF STANDARD CHARACTERS WITHOUT CLAIM TO ANY PARTICULAR FONT, STYLE, SIZE, OR COLOR.

NO CLAIM IS MADE TO THE EXCLUSIVE RIGHT TO USE "PET PRODUCTS", APART FROM THE MARK AS SHOWN.

FOR RETAIL STORE AND ON-LINE RETAIL STORE SERVICES FEATURING PET PRODUCTS (U.S. CLS. 100, 101 AND 102).

FIRST USE 10-1-2011; IN COMMERCE 10-1-2011.
DAVID HOFFMAN, EXAMINING ATTORNEY

SN 85-446,274. LASER INSTITUTE OF AMERICA, ORLANDO, FL. FILED 10-13-2011.

LME

THE MARK CONSISTS OF STANDARD CHARACTERS WITHOUT CLAIM TO ANY PARTICULAR FONT, STYLE, SIZE, OR COLOR.

FOR ARRANGING AND CONDUCTING TRADE SHOWS IN THE FIELD OF LASERS (U.S. CLS. 100, 101 AND 102).

FIRST USE 9-27-2011; IN COMMERCE 9-27-2011.
PATRICIA EVANKO, EXAMINING ATTORNEY

CLASS 35—(Continued).

SN 85-446,296. SOFT TEK SOLUTIONS, INC., MIAMI, FL.
FILED 10-13-2011.

SIXERR

THE MARK CONSISTS OF STANDARD CHARACTERS WITHOUT CLAIM TO ANY PARTICULAR FONT, STYLE, SIZE, OR COLOR.

FOR OPERATING ON-LINE MARKETPLACES FOR SELLERS OF GOODS AND/OR SERVICES (U.S. CLS. 100, 101 AND 102).

FIRST USE 9-5-2011; IN COMMERCE 9-5-2011.
JAMES GRIFFIN, EXAMINING ATTORNEY

CLASS 35—(Continued).

SN 85-446,306. BANTRA CORPORATION, CHARLOTTE, NC.
FILED 10-13-2011.

WHEN EVERY PIECE MATTERS

THE MARK CONSISTS OF STANDARD CHARACTERS WITHOUT CLAIM TO ANY PARTICULAR FONT, STYLE, SIZE, OR COLOR.

FOR BUSINESS MARKETING AND DIRECT MAIL CONSULTING SERVICES; BUSINESS SERVICES IN THE NATURE OF POSTAL ADDRESS VERIFICATION SERVICES; DATA PROCESSING SERVICES; DIRECT MAIL ADVERTISING SERVICES; DIRECT MARKETING; DIRECT MARKETING ADVERTISING FOR OTHERS; DISTRIBUTION AND DISSEMINATION OF ADVERTISING MATERIALS; DISTRIBUTION OF ADVERTISEMENTS AND COMMERCIAL ANNOUNCEMENTS; DISTRIBUTION OF ADVERTISING MATERIALS; INFORMATION AND DATA COMPILING AND ANALYZING RELATING TO BUSINESS MANAGEMENT; ORDER FULFILLMENT SERVICES (U.S. CLS. 100, 101 AND 102).

FIRST USE 10-1-2011; IN COMMERCE 10-1-2011.
JAMES GRIFFIN, EXAMINING ATTORNEY

SN 85-446,321. THE SOARING CORPORATION, DBA SOARING CONTACT CENTERS, MIAMI, FL. FILED 10-13-2011.



The logo for Soaring Contact Centers features the word "Soaring" in a large, bold, sans-serif font. Below it, the words "Contact Centers" are written in a smaller, bold, sans-serif font. The letters "I" and "N" in "Soaring" are stylized with horizontal lines passing through them.

SN 85-446,302. NETWORKED INSIGHTS, INC., MADISON, WI. FILED 10-13-2011.

NETWORKED INSIGHTS

THE MARK CONSISTS OF STANDARD CHARACTERS WITHOUT CLAIM TO ANY PARTICULAR FONT, STYLE, SIZE, OR COLOR.

OWNER OF U.S. REG. NO. 3,284,335.
FOR BUSINESS ADVICE AND ANALYSIS OF MARKETS; BUSINESS CONSULTATION AND MANAGEMENT REGARDING MARKETING ACTIVITIES AND LAUNCHING OF NEW PRODUCTS; MARKET ANALYSIS; MARKET RESEARCH CONSULTATION; MARKET RESEARCH SERVICES; SOCIAL MEDIA STRATEGY AND MARKETING CONSULTANCY FOCUSING ON HELPING CLIENTS CREATE AND EXTEND THEIR PRODUCT AND BRAND STRATEGIES BY BUILDING VIRALLY ENGAGING MARKETING SOLUTIONS (U.S. CLS. 100, 101 AND 102).

FIRST USE 5-30-2006; IN COMMERCE 5-30-2006.
JAMES GRIFFIN, EXAMINING ATTORNEY

NO CLAIM IS MADE TO THE EXCLUSIVE RIGHT TO USE "CONTACT CENTERS", APART FROM THE MARK AS SHOWN.

THE MARK CONSISTS OF THE WORD "SOARING" ABOVE THE WORDS "CONTACT CENTERS", WITH 4 COLUMNS CREATED BY HORIZONTAL LINES, RISING FROM LEFT TO RIGHT AND EMBEDDED WITHIN THE VERTICAL PORTIONS OF THE LETTERS "RIN" IN "SOARING".

FOR BUSINESS SERVICES, NAMELY, TELEPHONE MANAGEMENT AND ACCOUNTING REPORT SERVICES; COMPUTERIZED DATABASE MANAGEMENT SERVICES; TELEMARKETING SERVICES; DATA PROCESSING SERVICES IN THE FIELDS OF INTERNAL TELECOMMUNICATIONS SYSTEMS AND INFORMATION MANAGEMENT SYSTEMS; BUSINESS CONSULTING SERVICES IN THE FIELDS OF INTERNAL COMMUNICATION SYSTEMS AND INFORMATION PROCESSING AND INFORMATION MANAGEMENT SYSTEMS; ACCOUNT MANAGEMENT SERVICES IN THE FIELDS OF INTERNAL TELECOMMUNICATION SYSTEMS; TELECOMMUNICATION BILLING; GENERATING REPORTS DETAILING CUSTOMER USAGE OF TELECOMMUNICATIONS EQUIPMENT; PROVIDING OUTSOURCED CUSTOMER SUPPORT SERVICES FOR OTHERS IN THE NATURE OF INFORMATION MANAGEMENT AND ANSWERING CUSTOMER INQUIRIES THROUGH TELEPHONIC, ELECTRONIC, AND WORLDWIDE COMPUTER NETWORK-BASED MEANS; BILLING SERVICES, NAMELY, BILLING FOR TELECOMMUNICATION, CABLE, BROADBAND, SATELLITE, INTERNET SERVICE PROVIDERS, HEALTHCARE PROVIDERS, INSURANCE PROVIDERS, FINANCIAL SERVICE PROVIDERS, CORPORATIONS,

CLASS 35—(Continued).

GOVERNMENT ENTITIES, RETAIL, AUTOMOTIVE, COMPUTER SOFTWARE AND UTILITIES; PROVIDING OUTSOURCED CUSTOMER SUPPORT SERVICES FOR TELECOMMUNICATIONS, CABLE, BROADBAND, SATELLITE, INTERNET SERVICE PROVIDERS, HEALTH-CARE PROVIDERS, INSURANCE PROVIDERS, FINANCIAL SERVICE PROVIDERS, CORPORATIONS, GOVERNMENT ENTITIES, RETAIL, AUTOMOTIVE, COMPUTER SOFTWARE AND UTILITIES IN THE NATURE OF INFORMATION MANAGEMENT AND ANSWERING CUSTOMER INQUIRIES THROUGH TELEPHONIC, ELECTRONIC, WIRELESS, FACSIMILE, AND INTERNET-BASED MEANS; EMPLOYEE RELATIONS INFORMATION SERVICES; PAYROLL PREPARATION; ADMINISTRATION OF BUSINESS PAYROLL FOR OTHERS; EMPLOYMENT COUNSELING AND RECRUITING; EMPLOYMENT HIRING, RECRUITING, PLACEMENT, STAFFING AND CAREER NETWORKING SERVICES; EMPLOYMENT OUTPLACEMENT SERVICES; RECORD MANAGEMENT, NAMELY, DOCUMENT INDEXING FOR OTHERS; BUSINESS MANAGEMENT PLANNING; BUSINESS PLANNING (U.S. CLS. 100, 101 AND 102).

FIRST USE 10-1-2011; IN COMMERCE 10-1-2011,
WILLIAM JACKSON, EXAMINING ATTORNEY

SN 85-446,345. HYPNOTIC DONUTS LLC, DALLAS, TX.
FILED 10-13-2011.



NO CLAIM IS MADE TO THE EXCLUSIVE RIGHT TO USE "DONUTS", APART FROM THE MARK AS SHOWN.

THE MARK CONSISTS OF THE WORDS "HYPNOTIC DONUTS" ABOVE A SPIRAL DESIGN, WITH THE "O" IN THE WORD "HYPNOTIC" APPEARING AS A SPIRAL DESIGN AND THE "O" IN THE WORD "DONUTS" APPEARING AS A DONUT WITH SQUIGGLY LINES. THE WEB ADDRESS HYPNOTICDONUTS.COM APPEARS IN THE BOTTOM OF THE SPIRAL DESIGN.

FOR RETAIL STORE SERVICES FEATURING DONUTS, PASTRIES AND BISCUIT SANDWICHES FOR CONSUMPTION OFF THE PREMISES (U.S. CLS. 100, 101 AND 102).

FIRST USE 1-5-2010; IN COMMERCE 7-8-2010,
JENNIFER WILLISTON, EXAMINING ATTORNEY

CLASS 35—(Continued).

SN 85-446,361. PHARMACY BUYING ASSOCIATION, INC.,
KANSAS CITY, MO. FILED 10-13-2011.

PROFITGUARD

THE MARK CONSISTS OF STANDARD CHARACTERS WITHOUT CLAIM TO ANY PARTICULAR FONT, STYLE, SIZE, OR COLOR.

FOR ADMINISTERING GROUP PURCHASING PROGRAMS FOR INDEPENDENT RETAIL PHARMACIES, NAMELY, NEGOTIATING CONTRACTS WITH PROVIDERS OF PRODUCTS TO RETAIL PHARMACIES TO ENABLE PARTICIPANT MEMBERS TO OBTAIN DISCOUNTS ON THE PURCHASE OF PHARMACY PRODUCTS (U.S. CLS. 100, 101 AND 102).

FIRST USE 4-30-2009; IN COMMERCE 4-30-2009,
AMY ALFIERI, EXAMINING ATTORNEY

SN 85-446,399. NOBLE JEWELERS, INC., AUBURN, AL.
FILED 10-13-2011.

INTRIGUE JEWELERS

THE MARK CONSISTS OF STANDARD CHARACTERS WITHOUT CLAIM TO ANY PARTICULAR FONT, STYLE, SIZE, OR COLOR.

NO CLAIM IS MADE TO THE EXCLUSIVE RIGHT TO USE "JEWELERS", APART FROM THE MARK AS SHOWN.

FOR RETAIL STORE SERVICES FEATURING JEWELRY (U.S. CLS. 100, 101 AND 102).

FIRST USE 0-0-2003; IN COMMERCE 0-0-2003,
ERNEST SHOSHO, EXAMINING ATTORNEY

SN 85-446,407. THE SWEETBERRY, LLC, CUTLER BAY, FL.
FILED 10-13-2011.



THE MARK CONSISTS OF THE TEXT "THE" IN TIMES NEW ROMAN FONT AND ABOVE THE LETTER "W" IN "SWEET", "SWEETBERRY" IN HANDWRITING-DAKOTA FONT, AND A 'BERRY' ABOVE THE LETTERS "RY" IN "BERRY".

FOR RETAIL SHOPS FEATURING CANDY STATIONS AND BAKED GOODS (U.S. CLS. 100, 101 AND 102).

FIRST USE 3-23-2011; IN COMMERCE 3-23-2011,
ANNE FARRELL, EXAMINING ATTORNEY

CLASS 35—(Continued).

SN 85-446,412. STROKIN, LLC, CHASKA, MN. FILED 10-13-2011.

POWER PURCHASER CLUB

THE MARK CONSISTS OF STANDARD CHARACTERS WITHOUT CLAIM TO ANY PARTICULAR FONT, STYLE, SIZE, OR COLOR.

NO CLAIM IS MADE TO THE EXCLUSIVE RIGHT TO USE "PURCHASER CLUB", APART FROM THE MARK AS SHOWN.

FOR CUSTOMER LOYALTY SERVICES AND PROGRAMS, FOR COMMERCIAL, PROMOTIONAL AND/OR ADVERTISING PURPOSES, NOT IN THE ENERGY OR ELECTRICITY FIELDS (U.S. CLS. 100, 101 AND 102).

ELISSA GARBER KON, EXAMINING ATTORNEY

SN 85-446,419. TKT & ASSOCIATES, INC., LOUISVILLE, KY. FILED 10-13-2011.

TKT & ASSOCIATES, INC.

THE MARK CONSISTS OF STANDARD CHARACTERS WITHOUT CLAIM TO ANY PARTICULAR FONT, STYLE, SIZE, OR COLOR.

NO CLAIM IS MADE TO THE EXCLUSIVE RIGHT TO USE "ASSOCIATES, INC.", APART FROM THE MARK AS SHOWN.

FOR BUSINESS CONSULTING SERVICES IN THE FIELD OF SUPPLIER DIVERSITY, TALENT ACQUISITION, RECRUITMENT, AND HUMAN RESOURCE DEVELOPMENT; BUSINESS CONSULTING SERVICES, NAMELY, PROVIDING ASSISTANCE IN DEVELOPMENT OF BUSINESS STRATEGIES AND CREATIVE IDEATION (U.S. CLS. 100, 101 AND 102).

FIRST USE 4-30-2006; IN COMMERCE 4-30-2006.
CHRISTOPHER LAW, EXAMINING ATTORNEY

SN 85-446,425. STROKIN, LLC, CHASKA, MN. FILED 10-13-2011.

POWER PURCHASER

THE MARK CONSISTS OF STANDARD CHARACTERS WITHOUT CLAIM TO ANY PARTICULAR FONT, STYLE, SIZE, OR COLOR.

NO CLAIM IS MADE TO THE EXCLUSIVE RIGHT TO USE "PURCHASER", APART FROM THE MARK AS SHOWN.

FOR CUSTOMER LOYALTY SERVICES AND PROGRAMS, FOR COMMERCIAL, PROMOTIONAL AND/OR ADVERTISING PURPOSES, NOT IN THE ENERGY OR ELECTRICITY FIELDS (U.S. CLS. 100, 101 AND 102).

ELISSA GARBER KON, EXAMINING ATTORNEY

CLASS 35—(Continued).

SN 85-446,498. ROBERT SCHULLER, WARWICK, NY. FILED 10-13-2011.

COMMON COUPON

THE MARK CONSISTS OF STANDARD CHARACTERS WITHOUT CLAIM TO ANY PARTICULAR FONT, STYLE, SIZE, OR COLOR.

NO CLAIM IS MADE TO THE EXCLUSIVE RIGHT TO USE "COUPON", APART FROM THE MARK AS SHOWN.

FOR ADVERTISING SERVICES, NAMELY, PROMOTING AND MARKETING THE GOODS AND SERVICES OF OTHERS THROUGH ALL PUBLIC COMMUNICATION MEANS; ADVERTISING SERVICES, NAMELY, PROMOTING THE BRANDS, GOODS AND SERVICES OF OTHERS; ADVERTISING, MARKETING, AND PROMOTING THE GOODS AND SERVICES OF OTHERS VIA A WEBSITE; MARKETING SERVICES, NAMELY, PROMOTING OR ADVERTISING THE GOODS AND SERVICES OF OTHERS; MARKETING, ADVERTISING, AND PROMOTING THE RETAIL GOODS AND SERVICES OF OTHERS THROUGH WIRELESS ELECTRONIC DEVICES; PROMOTING AND MARKETING THE GOODS AND SERVICES OF OTHERS BY DISTRIBUTING ADVERTISING MATERIAL, COUPONS AND DISCOUNT OFFERS VIA TEXT MESSAGES; PROMOTING THE GOODS AND SERVICES OF OTHERS BY MEANS OF DISTRIBUTING ADVERTISING ON THE INTERNET; PROMOTING THE GOODS AND SERVICES OF OTHERS BY PROVIDING A COMMUNITY-DRIVEN WEB SITE FEATURING USER-SUBMITTED CONTENT IN THE NATURE OF COUPONS, REBATES, PRICE-COMPARISON INFORMATION, PRODUCT REVIEWS, LINKS TO THE RETAIL WEB SITES OF OTHERS, AND DISCOUNT INFORMATION; PROMOTING THE GOODS AND SERVICES OF OTHERS BY PROVIDING A WEB SITE AT WHICH USERS CAN LINK TO RETAILER'S WEBSITES; PROMOTING THE GOODS AND SERVICES OF OTHERS BY PROVIDING A WEBSITE FEATURING COUPONS, REBATES, PRICE-COMPARISON INFORMATION, PRODUCT REVIEWS, LINKS TO THE RETAIL WEBSITES OF OTHERS, AND DISCOUNT INFORMATION; PROMOTING THE GOODS AND SERVICES OF OTHERS BY PROVIDING A WEBSITE FEATURING COUPONS, DISCOUNT INFORMATION, AND PROMOTIONAL MATERIALS; PROMOTING THE GOODS AND SERVICES OF OTHERS BY PROVIDING HYPERTEXT LINKS TO THE WEB SITES OF OTHERS; PROMOTING THE GOODS AND SERVICES OF OTHERS BY PROVIDING A COMMUNITY DRIVEN WEBSITE, WHERE COUPONS CAN BE DOWNLOADED AND CONSUMERS CAN RECEIVE OTHER DISCOUNT INFORMATION; PROMOTING THE GOODS AND SERVICES OF OTHERS VIA A GLOBAL COMPUTER NETWORK; PROMOTING THE GOODS OF OTHERS, NAMELY, PROVIDING COUPONS, REBATES AND VOUCHERS FOR THE GOODS OF OTHERS; PROMOTING THE GOODS OF OTHERS, NAMELY, PROVIDING INFORMATION REGARDING DISCOUNTS, COUPONS, REBATES, VOUCHERS AND SPECIAL OFFERS FOR THE GOODS OF OTHERS; PROMOTIONAL SERVICES, NAMELY, PROMOTING THE GOODS OF OTHERS BY MEANS OF PROVIDING ONLINE COUPONS; PROMOTIONAL SERVICES, NAMELY, PROMOTING THE GOODS OF OTHERS BY PROVIDING ONLINE COUPONS AND RESTAURANT MENUS (U.S. CLS. 100, 101 AND 102).

FIRST USE 10-1-2011; IN COMMERCE 10-1-2011.
CARYN GLASSER, EXAMINING ATTORNEY

CLASS 35—(Continued).

SN 85-446,519. PONGR, INC., BOSTON, MA. FILED 10-13-2011.

See Snap Buy

THE MARK CONSISTS OF STANDARD CHARACTERS WITHOUT CLAIM TO ANY PARTICULAR FONT, STYLE, SIZE, OR COLOR.

FOR ADVERTISING, MARKETING, AND PROMOTIONAL SERVICES, NAMELY, PROVIDING PRODUCT INFORMATION VIA PUBLIC AND PRIVATE WIRELESS NETWORKS FOR DISPLAY ON MOBILE DEVICES, FOR ADVERTISING AND SALES PURPOSES; PROMOTIONAL SERVICES, NAMELY, PROVIDING INFORMATION BASED ON IMAGE RECOGNITION TECHNOLOGY ABOUT THE GOODS AND SERVICES OF OTHERS VIA THE INTERNET OR OTHER COMPUTER OR COMMUNICATIONS NETWORKS, PARTICULARLY SPECIALIZING IN THE USE OF SOCIAL MEDIA NETWORKS FOR PROMOTIONAL AND MARKETING PURPOSES (U.S. CLS. 100, 101 AND 102).

KIMBERLY FRYE, EXAMINING ATTORNEY

CLASS 35—(Continued).

SN 85-446,545. CHEMLOGIX, LLC, BLUE BELL, PA. FILED 10-13-2011.

CHEMLOGIX GLOBAL

THE MARK CONSISTS OF STANDARD CHARACTERS WITHOUT CLAIM TO ANY PARTICULAR FONT, STYLE, SIZE, OR COLOR.

OWNER OF U.S. REG. NO. 3,814,126.

NO CLAIM IS MADE TO THE EXCLUSIVE RIGHT TO USE "GLOBAL", APART FROM THE MARK AS SHOWN, FOR BUSINESS MANAGEMENT SERVICES, NAMELY, MANAGING LOGISTICS, REVERSE LOGISTICS, SUPPLY CHAIN SERVICES, SUPPLY CHAIN VISIBILITY AND SYNCHRONIZATION, SUPPLY AND DEMAND FORECASTING AND PRODUCT DISTRIBUTION PROCESSES FOR OTHERS (U.S. CLS. 100, 101 AND 102).

FIRST USE 4-30-2010; IN COMMERCE 4-30-2010.

JEFFREY LOOK, EXAMINING ATTORNEY

SN 85-446,562. SETIEN, JOSE J, ORLANDO, FL. FILED 10-13-2011.

SN 85-446,526. MADEWELL INC., NEW YORK, NY. FILED 10-13-2011.

MADEWELL BEACH SHACK

THE MARK CONSISTS OF STANDARD CHARACTERS WITHOUT CLAIM TO ANY PARTICULAR FONT, STYLE, SIZE, OR COLOR.

OWNER OF U.S. REG. NOS. 968,685, 3,957,991 AND OTHERS.

FOR RETAIL STORE SERVICES IN THE FIELDS OF CLOTHING, FOOTWEAR, HANDBAGS, AND JEWELRY (U.S. CLS. 100, 101 AND 102).

FIRST USE 5-15-2011; IN COMMERCE 5-15-2011.

ODESSA BIBBINS, EXAMINING ATTORNEY



THE MARK CONSISTS OF A CHARACTER ON THE LETTER "Y" OF WORD "YUMMIELAND". CONSISTING OF THE LETTER "Y" ARE SWOOSHES OF BROW AND SMALL CHERRIES, A SMILING FACE INSIDE THE "Y" WITH A WINKING EYE AND THE OTHER EYE IS A SMALL CHERRY. THERE IS A TONGUE LICKING HIS SMILEY MOUTH, A SPOON AS THE BOTTOM OF THE LETTER "Y". THERE IS A MINT LEAF IN THE TOP OF THE SPOON ON THE LETTER "Y". THERE IS A CHERRY AS THE DOT ON THE LETTER "I".

FOR SELF-SERVE FROZEN YOGURT SHOP SERVICES (U.S. CLS. 100, 101 AND 102).

FIRST USE 4-1-2011; IN COMMERCE 4-5-2011.

JUSTINE D. PARKER, EXAMINING ATTORNEY

CLASS 35—(Continued).

SN 85-446,618. ORR CORPORATION, LOUISVILLE, KY. FILED 10-13-2011.

WORKER SAFETY MEANS BUSINESS

THE MARK CONSISTS OF STANDARD CHARACTERS WITHOUT CLAIM TO ANY PARTICULAR FONT, STYLE, SIZE, OR COLOR.

FOR DISTRIBUTORSHIP SERVICES IN THE FIELD OF ALL FORMS OF SAFETY EQUIPMENT (U.S. CLS. 100, 101 AND 102).

KATHY DE JONGE, EXAMINING ATTORNEY

SN 85-446,718. GUNNING & ASSOCIATES MARKETING, INC., MILFORD, OH. FILED 10-13-2011.

GAServiceMax

THE MARK CONSISTS OF STANDARD CHARACTERS WITHOUT CLAIM TO ANY PARTICULAR FONT, STYLE, SIZE, OR COLOR.

FOR ADVERTISING, MARKETING AND PROMOTION SERVICES IN THE FIELD OF AUTOMOTIVE DEALERSHIPS (U.S. CLS. 100, 101 AND 102).

FIRST USE 9-19-2011; IN COMMERCE 9-19-2011. JAY FLOWERS, EXAMINING ATTORNEY

SN 85-446,820. SENIOR ADVISORY GROUP OF AMERICA LLC, DBA SENIOR ADVISORY GROUP, SCOTTSDALE, AZ. FILED 10-13-2011.

iCAMPAIGN

THE MARK CONSISTS OF STANDARD CHARACTERS WITHOUT CLAIM TO ANY PARTICULAR FONT, STYLE, SIZE, OR COLOR.

FOR MARKETING SERVICES, NAMELY, THE PROVISION OF PROMOTIONAL SERVICES AND MARKETING INFORMATION PERTAINING TO THE MARKETING OF FINANCIAL PRODUCTS AND SERVICES SUCH AS BROKERING INSURANCE AND ANNUITIES (U.S. CLS. 100, 101 AND 102).

FIRST USE 3-1-2011; IN COMMERCE 4-1-2011. JORDAN BAKER, EXAMINING ATTORNEY

CLASS 35—(Continued).

SN 85-446,845. URBAN RENEWAL, ENCINITAS, CA. FILED 10-13-2011.

Grassroots Nutrition

THE MARK CONSISTS OF STANDARD CHARACTERS WITHOUT CLAIM TO ANY PARTICULAR FONT, STYLE, SIZE, OR COLOR.

NO CLAIM IS MADE TO THE EXCLUSIVE RIGHT TO USE "NUTRITION", APART FROM THE MARK AS SHOWN.

FOR RETAIL STORE AND ON-LINE RETAIL STORE SERVICES FEATURING VITAMINS, NUTRITIONAL SUPPLEMENTS AND DIETARY SUPPLEMENTS (U.S. CLS. 100, 101 AND 102).

REBECCA SMITH, EXAMINING ATTORNEY

SN 85-446,897. HELENA HOLDING COMPANY, WILMINGTON, DE. FILED 10-13-2011.

GROLINK

THE MARK CONSISTS OF STANDARD CHARACTERS WITHOUT CLAIM TO ANY PARTICULAR FONT, STYLE, SIZE, OR COLOR.

FOR RECORD KEEPING SERVICES, NAMELY, DATA MANAGEMENT SERVICES OF FIELD RECORDS GENERATED DURING FARMING PRODUCTION (U.S. CLS. 100, 101 AND 102).

DAVID YONTEF, EXAMINING ATTORNEY

SN 85-446,898. PERFORM GROUP, LLC, YORK, PA. FILED 10-13-2011.

YOUR PERFORMANCE IS OUR PASSION

THE MARK CONSISTS OF STANDARD CHARACTERS WITHOUT CLAIM TO ANY PARTICULAR FONT, STYLE, SIZE, OR COLOR.

FOR COMPUTERIZED ON-LINE RETAIL STORE SERVICES IN THE FIELD OF APPAREL FOR DANCERS, MAJORETTES, CHEERLEADERS AND PARADE PERFORMANCE UNITS; MAIL ORDER CATALOG SERVICES FEATURING APPAREL FOR DANCERS, MAJORETTES, CHEERLEADERS AND PARADE PERFORMANCE UNITS (U.S. CLS. 100, 101 AND 102).

FIRST USE 8-15-2011; IN COMMERCE 8-15-2011. CHRISTOPHER BUONGIORNO, EXAMINING ATTORNEY

CLASS 35—(Continued).

SN 85-446,926. THE INTERIOR BOUTIQUE, LLC, TEMPLE HILLS, MD. FILED 10-13-2011.



OWNER OF U.S. REG. NO. 4,071,382.
NO CLAIM IS MADE TO THE EXCLUSIVE RIGHT TO USE "THE INTERIOR BOUTIQUE, LLC", APART FROM THE MARK AS SHOWN.

THE MARK CONSISTS OF "THE INTERIOR BOUTIQUE, LLC" STYLIZED WITH A LAMP BEING USED AS THE SECOND "I" IN THE WORD "INTERIOR".

FOR ON-LINE RETAIL STORE SERVICES FEATURING A WIDE VARIETY OF CONSUMER GOODS OF OTHERS (U.S. CLS. 100, 101 AND 102).

FIRST USE 5-7-2010. THE MARK WAS FIRST USED ANYWHERE IN A DIFFERENT FORM OTHER THAN THAT SOUGHT TO BE REGISTERED AT LEAST AS EARLY AS 05/07/2010.; IN COMMERCE 5-7-2010. THE MARK WAS FIRST USED IN COMMERCE IN A DIFFERENT FORM OTHER THAN THAT SOUGHT TO BE REGISTERED AT LEAST AS EARLY AS 05/07/2010..

NAAKWAMA ANKRAH, EXAMINING ATTORNEY

CLASS 35—(Continued).

SN 85-447,108. GLOBAL SUMMIT OF WOMEN, WASHINGTON, DC. FILED 10-13-2011.



THE COLOR(S) BLUE AND TURQUOISE IS/ARE CLAIMED AS A FEATURE OF THE MARK.

THE MARK CONSISTS OF A STYLIZED TURQUOISE GLOBE INSIDE A BLUE WOMEN'S SYMBOL.

FOR ARRANGING AND CONDUCTING BUSINESS CONFERENCES (U.S. CLS. 100, 101 AND 102).

FIRST USE 1-1-1990; IN COMMERCE 1-1-1990.

RON FAIRBANKS, EXAMINING ATTORNEY

SN 85-447,150. MYCOSKIE, LLC, SANTA MONICA, CA. FILED 10-13-2011.

SN 85-446,932. MASTER BRANDS, LLC, WASHINGTON, CT. FILED 10-13-2011.

MASTER BRANDS

THE MARK CONSISTS OF STANDARD CHARACTERS WITHOUT CLAIM TO ANY PARTICULAR FONT, STYLE, SIZE, OR COLOR.

NO CLAIM IS MADE TO THE EXCLUSIVE RIGHT TO USE "BRANDS", APART FROM THE MARK AS SHOWN.

FOR WHOLESALE DISTRIBUTORSHIPS FEATURING WINES (U.S. CLS. 100, 101 AND 102).

MARK SPARACINO, EXAMINING ATTORNEY

ONE FOR ONE

THE MARK CONSISTS OF STANDARD CHARACTERS WITHOUT CLAIM TO ANY PARTICULAR FONT, STYLE, SIZE, OR COLOR.

FOR RETAIL STORE SERVICES AND ON-LINE RETAIL STORE SERVICES IN THE FIELD OF FOOTWEAR, APPAREL, EYEWEAR, JEWELRY, BOOKS, JOURNALS, AND GIFT PACKS CONSISTING OF DVDS AND POSTERS (U.S. CLS. 100, 101 AND 102).

FIRST USE 5-15-2006; IN COMMERCE 5-15-2006.

BILL DAWE, EXAMINING ATTORNEY

CLASS 35—(Continued).

SN 85-447,156. BAE SYSTEMS TACTICAL VEHICLE SYSTEMS LP, SEALY, TX. FILED 10-13-2011.

CLASS 35—(Continued).

SN 85-447,350. ESCHER ANALYTICS LLC, MEDIA, PA. FILED 10-14-2011.

NO ROAD NO PROBLEM

THE MARK CONSISTS OF STANDARD CHARACTERS WITHOUT CLAIM TO ANY PARTICULAR FONT, STYLE, SIZE, OR COLOR.

FOR PROMOTING THE SALE OF GOODS AND SERVICES OF OTHERS IN THE TRUCK INDUSTRY BY DISSEMINATION OF PROMOTIONAL MATERIALS AND PRODUCT INFORMATION THROUGH AN ON-LINE GLOBAL COMPUTER NETWORK, THROUGH THE DISTRIBUTION OF PRINTED MATERIAL, VIDEO TAPES, TELEVISION BROADCASTS, INTERNET WEB SITES, AND PROMOTIONAL CONTESTS; RETAIL STORE SERVICES IN THE FIELD OF TRUCKS, TRUCK PARTS AND ACCESSORIES; AND DEALERSHIP SERVICES IN THE FIELD OF TRUCKS (U.S. CLS. 100, 101 AND 102).

LUCY ARANT, EXAMINING ATTORNEY

ESCHER ANALYTICS

THE MARK CONSISTS OF STANDARD CHARACTERS WITHOUT CLAIM TO ANY PARTICULAR FONT, STYLE, SIZE, OR COLOR.

NO CLAIM IS MADE TO THE EXCLUSIVE RIGHT TO USE "ANALYTICS", APART FROM THE MARK AS SHOWN.

FOR BUSINESS CONSULTING AND INFORMATION SERVICES; BUSINESS CONSULTING IN THE CONSUMER PRODUCTS INDUSTRY; BUSINESS MANAGEMENT CONSULTING WITH RELATION TO STRATEGY, MARKETING, SALES, OPERATION, PRODUCT DESIGN PARTICULARLY SPECIALIZING IN THE USE OF ANALYTIC AND STATISTIC MODELS FOR THE UNDERSTANDING AND PREDICTING OF CONSUMERS, BUSINESSES, AND MARKET TRENDS AND ACTIONS; BUSINESS MONITORING AND CONSULTING SERVICES, NAMELY, TRACKING WEB SITES AND APPLICATIONS OF OTHERS TO PROVIDE STRATEGY, INSIGHT, MARKETING, SALES, OPERATION, PRODUCT DESIGN, PARTICULARLY SPECIALIZING IN THE USE OF ANALYTIC AND STATISTIC MODELS FOR THE UNDERSTANDING AND PREDICTING OF CONSUMERS, BUSINESSES, AND MARKET TRENDS AND ACTIONS; CONSUMER STRATEGY BUSINESS CONSULTING IN THE FIELDS OF MARKETING, SALES, OPERATION, AND PRODUCT DESIGN PARTICULARLY SPECIALIZING IN THE USE OF ANALYTIC MODELS FOR THE UNDERSTANDING AND PREDICTING OF CONSUMER, BUSINESS, AND RETAIL MARKET TRENDS AND ACTIONS; MARKETING RESEARCH SERVICES; MARKETING SERVICES, NAMELY, CONDUCTING CONSUMER TRACKING BEHAVIOR RESEARCH AND CONSUMER TREND ANALYSIS; STATISTICAL ANALYSIS AND REPORTING SERVICES FOR BUSINESS PURPOSES (U.S. CLS. 100, 101 AND 102).

HOWARD B. LEVINE, EXAMINING ATTORNEY

SN 85-447,248. GOODWIN, RHONDA, AIKEN, SC. FILED 10-13-2011.

MOONSTAR7SPIRITS

THE MARK CONSISTS OF STANDARD CHARACTERS WITHOUT CLAIM TO ANY PARTICULAR FONT, STYLE, SIZE, OR COLOR.

FOR ONLINE RETAIL STORE SERVICES FEATURING JEWELRY, POTIONS, INCENSE, SPELLS, SPELL KITS, BEADS, SPELL CAST JEWELRY, PENDANTS, CHARMS (U.S. CLS. 100, 101 AND 102).

FIRST USE 2-1-2006; IN COMMERCE 2-1-2006.
GEORGE LORENZO, EXAMINING ATTORNEY

CLASS 35—(Continued).

SN 85-447,379. ESCHER ANALYTICS LLC, MEDIA, PA.
FILED 10-14-2011.

STRUCTURE FROM CHAOS

THE MARK CONSISTS OF STANDARD CHARACTERS WITHOUT CLAIM TO ANY PARTICULAR FONT, STYLE, SIZE, OR COLOR.

FOR BUSINESS CONSULTING AND INFORMATION SERVICES; BUSINESS CONSULTING IN THE CONSUMER PRODUCTS INDUSTRY; BUSINESS MANAGEMENT CONSULTING WITH RELATION TO STRATEGY, MARKETING, SALES, OPERATION, PRODUCT DESIGN PARTICULARLY SPECIALIZING IN THE USE OF ANALYTIC AND STATISTIC MODELS FOR THE UNDERSTANDING AND PREDICTING OF CONSUMERS, BUSINESSES, AND MARKET TRENDS AND ACTIONS; BUSINESS MONITORING AND CONSULTING SERVICES, NAMELY, TRACKING WEB SITES AND APPLICATIONS OF OTHERS TO PROVIDE STRATEGY, INSIGHT, MARKETING, SALES, OPERATION, PRODUCT DESIGN, PARTICULARLY SPECIALIZING IN THE USE OF ANALYTIC AND STATISTIC MODELS FOR THE UNDERSTANDING AND PREDICTING OF CONSUMERS, BUSINESSES, AND MARKET TRENDS AND ACTIONS; CONSUMER STRATEGY BUSINESS CONSULTING IN THE FIELDS OF MARKETING, SALES, OPERATION, AND PRODUCT DESIGN PARTICULARLY SPECIALIZING IN THE USE OF ANALYTIC MODELS FOR THE UNDERSTANDING AND PREDICTING OF CONSUMER, BUSINESS, AND RETAIL MARKET TRENDS AND ACTIONS; MARKETING RESEARCH SERVICES; MARKETING SERVICES, NAMELY, CONDUCTING CONSUMER TRACKING BEHAVIOR RESEARCH AND CONSUMER TREND ANALYSIS; STATISTICAL ANALYSIS AND REPORTING SERVICES FOR BUSINESS PURPOSES (U.S. CLS. 100, 101 AND 102).

HOWARD B. LEVINE, EXAMINING ATTORNEY

SN 85-447,388. ADVANCE MAGAZINE PUBLISHERS INC.,
NEW YORK, NY. FILED 10-14-2011.

CULTURAL FORESIGHTS

THE MARK CONSISTS OF STANDARD CHARACTERS WITHOUT CLAIM TO ANY PARTICULAR FONT, STYLE, SIZE, OR COLOR.

FOR ADVERTISING AGENCY SERVICES; ORGANIZING AND CONDUCTING MARKETING AND PROMOTIONS FOR OTHERS; BUSINESS CONSULTATION (U.S. CLS. 100, 101 AND 102).

TRACY FLETCHER, EXAMINING ATTORNEY

CLASS 35—(Continued).

SN 85-447,389. ADVANCE MAGAZINE PUBLISHERS INC.,
NEW YORK, NY. FILED 10-14-2011.

**CONDE NAST IDEACTIVE
CULTURE. APPLIED**

THE MARK CONSISTS OF STANDARD CHARACTERS WITHOUT CLAIM TO ANY PARTICULAR FONT, STYLE, SIZE, OR COLOR.

OWNER OF U.S. REG. NOS. 1,568,296, 3,102,717 AND OTHERS.

FOR ADVERTISING AGENCY SERVICES; ORGANIZING AND CONDUCTING MARKETING AND PROMOTIONS FOR OTHERS; BUSINESS CONSULTATION (U.S. CLS. 100, 101 AND 102).

TRACY FLETCHER, EXAMINING ATTORNEY

SN 85-447,390. ADVANCE MAGAZINE PUBLISHERS INC.,
NEW YORK, NY. FILED 10-14-2011.

CULTURE. APPLIED

THE MARK CONSISTS OF STANDARD CHARACTERS WITHOUT CLAIM TO ANY PARTICULAR FONT, STYLE, SIZE, OR COLOR.

FOR ADVERTISING AGENCY SERVICES; ORGANIZING AND CONDUCTING MARKETING AND PROMOTIONS FOR OTHERS; BUSINESS CONSULTATION (U.S. CLS. 100, 101 AND 102).

TRACY FLETCHER, EXAMINING ATTORNEY

SN 85-447,416. INTERBRANDS GROUP, LLC, THE WOODLANDS, TX. FILED 10-14-2011.

IMPORTING SUCCESS

THE MARK CONSISTS OF STANDARD CHARACTERS WITHOUT CLAIM TO ANY PARTICULAR FONT, STYLE, SIZE, OR COLOR.

FOR BUSINESS CONSULTING IN THE CONSUMER PRODUCTS INDUSTRY; BUSINESS CONSULTING SERVICES IN THE FIELD OF IMPORTING PRODUCTS TARGETING HISPANIC CONSUMERS; BUSINESS MANAGEMENT CONSULTING WITH RELATION TO STRATEGY, MARKETING, SALES, OPERATION, PRODUCT DESIGN PARTICULARLY SPECIALIZING IN THE USE OF ANALYTIC AND STATISTIC MODELS FOR THE UNDERSTANDING AND PREDICTING OF CONSUMERS, BUSINESSES, AND MARKET TRENDS AND ACTIONS; PRODUCT MERCHANDISING (U.S. CLS. 100, 101 AND 102).

FIRST USE 9-27-2011; IN COMMERCE 9-27-2011.

KATHERINE CHANG, EXAMINING ATTORNEY

CLASS 35—(Continued).

SN 85-447,451. CULTURE JAM, INC., VENICE, CA. FILED 10-14-2011.

PROMOJAM-GO!

THE MARK CONSISTS OF STANDARD CHARACTERS WITHOUT CLAIM TO ANY PARTICULAR FONT, STYLE, SIZE, OR COLOR.

OWNER OF U.S. REG. NOS. 3,842,982, 3,908,210 AND OTHERS.

FOR ADVERTISING AND DIRECTORY SERVICES, NAMELY, PROMOTING THE SERVICES OF OTHERS BY PROVIDING A WEB PAGE FEATURING LINKS TO THE WEBSITES OF OTHERS; ADVERTISING AND MARKETING SERVICES, NAMELY, PROMOTING THE GOODS AND SERVICES OF OTHERS; ADVERTISING AND PROMOTIONAL SERVICES; ADVERTISING AND PUBLICITY SERVICES, NAMELY, PROMOTING THE GOODS, SERVICES, BRAND IDENTITY AND COMMERCIAL INFORMATION AND NEWS OF THIRD PARTIES THROUGH PRINT, AUDIO, VIDEO, DIGITAL AND ON-LINE MEDIUM; ADVERTISING PARTICULARLY SERVICES FOR THE PROMOTION OF GOODS; ADVERTISING, INCLUDING PROMOTION RELATING TO THE SALE OF ARTICLES AND SERVICES FOR THIRD PARTIES BY THE TRANSMISSION OF ADVERTISING MATERIAL AND THE DISSEMINATION OF ADVERTISING MESSAGES ON COMPUTER NETWORKS; ADVERTISING, MARKETING AND PROMOTIONAL SERVICES RELATED TO ALL INDUSTRIES FOR THE PURPOSE OF FACILITATING NETWORKING AND SOCIALIZING OPPORTUNITIES FOR BUSINESS PURPOSES; ADVERTISING, PROMOTION AND MARKETING SERVICES IN THE NATURE OF E-MAIL BLAST CAMPAIGNS FOR OTHERS; ARRANGING AND CONDUCTING MARKETING PROMOTIONAL EVENTS FOR OTHERS; MARKETING, ADVERTISING, AND PROMOTING THE RETAIL GOODS AND SERVICES OF OTHERS TO WIRELESS ELECTRONIC DEVICES; MARKETING, PROMOTIONAL AND ADVERTISING SERVICES PROVIDED BY MOBILE TELEPHONE CONNECTIONS; ORGANISATION OF PROMOTIONS USING AUDIOVISUAL MEDIA; PROMOTING THE GOODS AND SERVICES OF OTHERS BY DISTRIBUTING ADVERTISING MATERIALS THROUGH A VARIETY OF METHODS; PROMOTING THE GOODS AND SERVICES OF OTHERS BY PROVIDING HYPERTEXT LINKS TO THE WEB SITES OF OTHERS; PROMOTING THE GOODS AND SERVICES OF OTHERS THROUGH SEARCH ENGINE REFERRAL TRAFFIC ANALYSIS AND REPORTING; PROMOTING THE GOODS AND SERVICES OF OTHERS VIA A GLOBAL COMPUTER NETWORK. PROMOTING THE GOODS OF OTHERS, NAMELY, PROVIDING COUPONS, REBATES AND VOUCHERS FOR THE GOODS OF OTHERS; PROMOTING, ADVERTISING AND MARKETING OF THE ON-LINE WEB SITES OF OTHERS; PROMOTION USING AUDIOVISUAL MEDIA; PROMOTION, ADVERTISING AND MARKETING OF ON-LINE WEBSITES; PROVIDING MARKETING AND PROMOTION OF SPECIAL EVENTS; PROVIDING PROMOTIONAL MARKETING SERVICES TO BUSINESSES IN THE BROADBAND AND MEDIA INDUSTRIES (U.S. CLS. 100, 101 AND 102).

FIRST USE 6-0-2011; IN COMMERCE 6-0-2011.

KRISTIN DAHLING, EXAMINING ATTORNEY

CLASS 35—(Continued).

SN 85-447,476. BEBEAU, KYLE JAMES, DBA REALEYEZ APPAREL, FORT MILL, SC. FILED 10-14-2011.



THE MARK CONSISTS OF A STYLIZED "R" ABOVE A CIRCLE.

FOR WHOLESALE DISTRIBUTORSHIP SERVICES AND ONLINE ORDERING SERVICES FEATURING CLOTHING, NAMELY, T-SHIRTS (U.S. CLS. 100, 101 AND 102).

FIRST USE 2-16-2009; IN COMMERCE 1-27-2010.

SIMON TENG, EXAMINING ATTORNEY

SN 85-447,485. HOANG, HOA, NORTH CHELMSFORD, MA. FILED 10-14-2011.

**WHERE A BUSINESS CAN BE A
BUSINESS**

THE MARK CONSISTS OF STANDARD CHARACTERS WITHOUT CLAIM TO ANY PARTICULAR FONT, STYLE, SIZE, OR COLOR.

FOR ADVERTISING SERVICES (U.S. CLS. 100, 101 AND 102).

SIMON TENG, EXAMINING ATTORNEY

CLASS 35—(Continued).

SN 85-447,502. GREENVILLE SPORTS & IMPORTS, INC., GREENVILLE, NC. FILED 10-14-2011.

ShopMyCars

THE MARK CONSISTS OF STANDARD CHARACTERS WITHOUT CLAIM TO ANY PARTICULAR FONT, STYLE, SIZE, OR COLOR.

FOR ADVERTISING, PROMOTION, AND MARKETING SERVICES IN THE NATURE OF LICENSE PLATES ADVERTISEMENTS, ONLINE BANNER ADS, MAGAZINE ADVERTISEMENTS, INTERNET SALES ADVERTISEMENTS, TV ADVERTISEMENTS, AND RADIO ADVERTISEMENTS FOR AUTOMOBILE AND TRUCK OWNERS.; COMPUTERIZED ON-LINE RETAIL STORE SERVICES IN THE FIELD OF AUTOMOBILES AND TRUCKS.; ON-LINE RETAIL STORE SERVICES FEATURING AUTOMOBILES AND TRUCKS.; PROVIDING INFORMATION ABOUT AUTOMOBILES FOR SALE BY MEANS OF THE INTERNET; PROVIDING INFORMATION IN THE FIELD OF THE AUTOMOBILE AND TRUCK INDUSTRY; RETAIL STORE SERVICES FEATURING AUTOMOBILES AND TRUCKS (U.S. CLS. 100, 101 AND 102).

FIRST USE 5-1-2009; IN COMMERCE 5-1-2009.
MARK T. MULLEN, EXAMINING ATTORNEY

SN 85-447,568. NEU IP, LLC, KANSAS CITY, MO. FILED 10-14-2011.

NEUANALYTICS

THE MARK CONSISTS OF STANDARD CHARACTERS WITHOUT CLAIM TO ANY PARTICULAR FONT, STYLE, SIZE, OR COLOR.

FOR BUSINESS DATA ANALYSIS; BUSINESS INFORMATION MANAGEMENT; BUSINESS INFORMATION MANAGEMENT, NAMELY, ELECTRONIC REPORTING OF BUSINESS INFORMATION, BUSINESS ANALYTICS, NAMELY, BUSINESS INVESTIGATIONS, EVALUATIONS, EXPERT APPRAISALS, INFORMATION AND RESEARCH, TRADE SPEND BUSINESS MANAGEMENT; BUSINESS PROCESS OUTSOURCING SERVICES IN THE FIELD OF FINANCE, CREDIT AND COLLECTIONS; BUSINESS SERVICES, NAMELY, REGISTERING, SCREENING, CREDENTIALING, AND ORGANIZING THIRD-PARTY VENDORS, SUPPLIERS, AND CONTRACTORS, AND DOCUMENTATION AND INFORMATION ON BEHALF OF OTHERS; COLLECTION AND COMPILATION OF INFORMATION INTO COMPUTER DATABASES IN THE FIELD OF FINANCE, CREDIT AND COLLECTIONS; COLLECTION AND SYSTEMATISATION OF INFORMATION INTO COMPUTER DATABASES; COMPILATION OF STATISTICS; DATA MANAGEMENT SERVICE FOR USE IN REPORTING DEBT COLLECTION ACCOUNTS TO A COLLECTION

CLASS 35—(Continued).

AGENCY; DATA MANAGEMENT SERVICES FOR USE IN DEBT COLLECTION, NAMELY, ELECTRONIC DATA COLLECTION AND ON-LINE CLAIMS MANAGEMENT; DATA PROCESSING SERVICES; INFORMATION AND DATA COMPILING AND ANALYZING RELATING TO BUSINESS MANAGEMENT; OUTSOURCING SERVICES; PREPARING FINANCIAL REPORTS FOR OTHERS; PROVIDING AN ON-LINE COMPUTER WEB SITE THAT PROVIDES COMMERCIAL FINANCIAL TRANSACTION DATA, ACCOUNT MANAGEMENT, FINANCIAL REPORTING, ACCOUNTING FEATURES AND RELATED REFERENCE INFORMATION; PROVIDING BUSINESS INFORMATION, NAMELY, COMMERCIAL CORPORATE AND STATISTICAL INFORMATION PROVIDED ON-LINE FROM A COMPUTER DATABASE OR THE INTERNET; PROVIDING BUSINESS INTELLIGENCE SERVICES; STATISTICAL ANALYSIS AND REPORTING SERVICES FOR BUSINESS PURPOSES; VENDOR MANAGEMENT SERVICES FOR FINANCIAL SERVICES, CREDIT AND COLLECTION (U.S. CLS. 100, 101 AND 102).

FIRST USE 8-0-2007; IN COMMERCE 8-0-2007.
KAPIL BHANOT, EXAMINING ATTORNEY

SN 85-447,597. MURRAY SMITH, DALLAS, TX. FILED 10-14-2011.

Revenue Labs

THE MARK CONSISTS OF STANDARD CHARACTERS WITHOUT CLAIM TO ANY PARTICULAR FONT, STYLE, SIZE, OR COLOR.

NO CLAIM IS MADE TO THE EXCLUSIVE RIGHT TO USE "REVENUE", APART FROM THE MARK AS SHOWN. FOR BUSINESS CONSULTATION IN THE FIELD OF SALES; CONSULTING IN THE FIELD OF SALES METHODS, SALES MANAGEMENT, AND SALES IMPROVEMENT (U.S. CLS. 100, 101 AND 102).

ADA HAN, EXAMINING ATTORNEY

SN 85-447,657. NEU IP, LLC, KANSAS CITY, MO. FILED 10-14-2011.

NEUFINANCIAL

THE MARK CONSISTS OF STANDARD CHARACTERS WITHOUT CLAIM TO ANY PARTICULAR FONT, STYLE, SIZE, OR COLOR.

FOR ADVISORY SERVICES RELATING TO BUSINESS MANAGEMENT AND BUSINESS OPERATIONS; ASSISTANCE IN MANAGEMENT OF BUSINESS ACTIVITIES; ASSISTANCE WITH BUSINESS MANAGEMENT AND PLANNING; BRANDING SERVICES, NAMELY, CONSULTING, DEVELOPMENT, MANAGEMENT AND MARKETING OF BRANDS FOR BUSINESSES; BUSINESS ADMINISTRATION AND MANAGEMENT; BUSINESS ADVICE AND INFORMATION; BUSINESS ANALYSIS AND BUSINESS STRATEGIC PLANNING SERVICES IN THE TECHNOLOGY INDUSTRY; BUSINESS MANAGEMENT (U.S. CLS. 100, 101 AND 102).

FIRST USE 1-0-2010; IN COMMERCE 1-0-2010.
KAPIL BHANOT, EXAMINING ATTORNEY

CLASS 35—(Continued).

SN 85-447,804. VOIGT, LAURA E., EAST AMHERST, NY. FILED 10-14-2011.

ELLY'S ANGELS

THE MARK CONSISTS OF STANDARD CHARACTERS WITHOUT CLAIM TO ANY PARTICULAR FONT, STYLE, SIZE, OR COLOR.

FOR CHARITABLE SERVICES, NAMELY, COORDINATION OF NON-MONETARY CONTRIBUTIONS TO CHARITIES AND NON-PROFITS; CHARITABLE SERVICES, NAMELY, ORGANIZING AND CONDUCTING VOLUNTEER PROGRAMS AND COMMUNITY SERVICE PROJECTS (U.S. CLS. 100, 101 AND 102).

FIRST USE 5-0-2009; IN COMMERCE 5-0-2009.
JESSICA A. POWERS, EXAMINING ATTORNEY

CLASS 35—(Continued).

SN 85-447,939. NEU IP, LLC, KANSAS CITY, MO. FILED 10-14-2011.

NEU CONSULTING GROUP

THE MARK CONSISTS OF STANDARD CHARACTERS WITHOUT CLAIM TO ANY PARTICULAR FONT, STYLE, SIZE, OR COLOR.

NO CLAIM IS MADE TO THE EXCLUSIVE RIGHT TO USE "CONSULTING GROUP", APART FROM THE MARK AS SHOWN.

FOR ACCOUNT AUDITING; ADVISORY SERVICES RELATING TO BUSINESS MANAGEMENT AND BUSINESS OPERATIONS; BUSINESS ADVICE AND INFORMATION; BUSINESS ADVISORY SERVICES, NAMELY, SEARCH FOR AND SELECTION OF THE BEST POTENTIAL SUPPLIERS FOR OTHERS; BUSINESS ANALYSIS AND BUSINESS STRATEGIC PLANNING SERVICES IN THE TECHNOLOGY INDUSTRY; BUSINESS AUDITING; BUSINESS CONSULTATION SERVICES IN THE FIELDS OF SUPPLY CHAIN ANALYSIS, REGULATION COMPLIANCE AND COUNTERFEIT DETECTION; BUSINESS CONSULTING AND BUSINESS INFORMATION FOR ENTERPRISES; BUSINESS CONSULTING AND INFORMATION SERVICES; BUSINESS DATA ANALYSIS; BUSINESS INFORMATION MANAGEMENT; BUSINESS INVOICING SERVICES; BUSINESS MANAGEMENT; BUSINESS MANAGEMENT CONSULTING; BUSINESS MANAGEMENT CONSULTING WITH RELATION TO STRATEGY, MARKETING, SALES, OPERATION, PRODUCT DESIGN PARTICULARLY SPECIALIZING IN THE USE OF ANALYTIC AND STATISTIC MODELS FOR THE UNDERSTANDING AND PREDICTING OF CONSUMERS, BUSINESSES, AND MARKET TRENDS AND ACTIONS; BUSINESS PROCESS OUTSOURCING SERVICES IN THE FIELD OF FINANCE; BUSINESS PROCESS RE-ENGINEERING SERVICES; BUSINESS RISK MANAGEMENT; COMMERCIAL INFORMATION AGENCIES; COMPILATION OF STATISTICS; INFORMATION AND DATA COMPILING AND ANALYZING RELATING TO BUSINESS MANAGEMENT; OUTSOURCING SERVICES; PROVIDING BUSINESS INFORMATION, NAMELY, COMMERCIAL CORPORATE AND STATISTICAL INFORMATION PROVIDED ON-LINE FROM A COMPUTER DATABASE OR THE INTERNET; PROVIDING BUSINESS INTELLIGENCE SERVICES; STATISTICAL ANALYSIS AND REPORTING SERVICES FOR BUSINESS PURPOSES; VENDOR MANAGEMENT SERVICES FOR FINANCE, CREDIT AND COLLECTIONS (U.S. CLS. 100, 101 AND 102).

FIRST USE 3-0-2007; IN COMMERCE 3-0-2007.
KAPIL BHANOT, EXAMINING ATTORNEY

SN 85-447,807. VELVET PALATE, NEW YORK, NY. FILED 10-14-2011.

VELVET CLUB

THE MARK CONSISTS OF STANDARD CHARACTERS WITHOUT CLAIM TO ANY PARTICULAR FONT, STYLE, SIZE, OR COLOR.

NO CLAIM IS MADE TO THE EXCLUSIVE RIGHT TO USE "CLUB", APART FROM THE MARK AS SHOWN.

FOR ADVERTISING SERVICES, NAMELY, PROMOTING THE FOOD AND WINE OF OTHERS (U.S. CLS. 100, 101 AND 102).

REBECCA SMITH, EXAMINING ATTORNEY

CLASS 35—(Continued).

SN 85-447,955. ELECTRONIC IMAGING SERVICES, INC., DBA VESTCOM RETAIL SOLUTIONS, LITTLE ROCK, AR. FILED 10-14-2011.

AisleWise

THE MARK CONSISTS OF STANDARD CHARACTERS WITHOUT CLAIM TO ANY PARTICULAR FONT, STYLE, SIZE, OR COLOR.

FOR MARKETING SERVICES, NAMELY, ARRANGING AND CONDUCTING MARKETING, PRODUCT PLACEMENT, PRODUCT PRICING, AND MERCHANDISING CAMPAIGNS FOR RETAILERS (U.S. CLS. 100, 101 AND 102).

RONALD MCMORROW, EXAMINING ATTORNEY

SN 85-447,960. PAPIER STUDIOS, LLC., WOODLAND HILLS, CA. FILED 10-14-2011.

CARDACITY

THE MARK CONSISTS OF STANDARD CHARACTERS WITHOUT CLAIM TO ANY PARTICULAR FONT, STYLE, SIZE, OR COLOR.

FOR PROMOTING THE GOODS AND SERVICES OF OTHERS BY PROVIDING AN INTERACTIVE WEBSITE WHERE USERS CAN INCREASE THE CURRENT VALUE OF AN ONLINE DISCOUNT BEING OFFERED BY PURCHASING THE GOODS AND SERVICES ASSOCIATED WITH THAT DISCOUNT IN THE FORM OF AN ONLINE COUPON, VOUCHER OR GIFT CARD; PROMOTIONAL SERVICES, NAMELY, PROMOTING THE GOODS OF OTHERS BY MEANS OF PROVIDING ONLINE COUPONS; PROMOTIONAL SERVICES, NAMELY, PROMOTING THE GOODS OF OTHERS BY MEANS OF PROVIDING ONLINE GIFT CARDS; PROMOTIONAL SERVICES, NAMELY, PROMOTING THE GOODS OF OTHERS BY MEANS OF PROVIDING ONLINE GIFT CERTIFICATES (U.S. CLS. 100, 101 AND 102).

AMY KERTGATE, EXAMINING ATTORNEY

SN 85-447,981. INTERNATIONAL LEAGUE AGAINST EPILEPSY, WEST HARTFORD, CT. FILED 10-14-2011.

STAND UP FOR EPILEPSY

THE MARK CONSISTS OF STANDARD CHARACTERS WITHOUT CLAIM TO ANY PARTICULAR FONT, STYLE, SIZE, OR COLOR.

FOR PROMOTING PUBLIC AWARENESS OF EPILEPSY AND THE PREVENTION, DIAGNOSIS AND TREATMENT OF EPILEPSY (U.S. CLS. 100, 101 AND 102).

LINDA LAVACHE, EXAMINING ATTORNEY

CLASS 35—(Continued).

SN 85-448,014. NATIONAL PEANUT BOARD, ATLANTA, GA. FILED 10-14-2011.

Energize Your World

THE MARK CONSISTS OF STANDARD CHARACTERS WITHOUT CLAIM TO ANY PARTICULAR FONT, STYLE, SIZE, OR COLOR.

FOR PROMOTING PUBLIC AWARENESS OF THE NUTRITIONAL BENEFITS AND MULTIPLE USES OF PEANUTS; PROMOTING THE INTERESTS OF PEANUT PRODUCERS (U.S. CLS. 100, 101 AND 102).

STEPHANIE ALI, EXAMINING ATTORNEY

SN 85-448,057. COMMUNICATE GOOD, LLC, PIKESVILLE, MD. FILED 10-14-2011.

COMMUNICATE GOOD

THE MARK CONSISTS OF STANDARD CHARACTERS WITHOUT CLAIM TO ANY PARTICULAR FONT, STYLE, SIZE, OR COLOR.

FOR BUSINESS CONSULTING SERVICES, NAMELY, PUBLIC RELATIONS CONSULTING SERVICES AND MARKETING-RELATED PROJECT MANAGEMENT SERVICES FOR INDIVIDUALS, BUSINESSES AND NOT FOR PROFIT ORGANIZATIONS (U.S. CLS. 100, 101 AND 102).

FIRST USE 5-13-2011; IN COMMERCE 10-13-2011.

BENJAMIN OKEKE, EXAMINING ATTORNEY

SN 85-448,062. NEUWEG, RYAN, KANSAS CITY, MO. FILED 10-14-2011.

NEUIDEAS

THE MARK CONSISTS OF STANDARD CHARACTERS WITHOUT CLAIM TO ANY PARTICULAR FONT, STYLE, SIZE, OR COLOR.

FOR ADVERTISING AND MARKETING SERVICES, NAMELY, PROMOTING THE GOODS AND SERVICES OF OTHERS; BRANDING SERVICES, NAMELY, CONSULTING, DEVELOPMENT, MANAGEMENT AND MARKETING OF BRANDS FOR BUSINESSES; BUSINESS ADVICE AND INFORMATION; BUSINESS ANALYSIS AND BUSINESS STRATEGIC PLANNING SERVICES IN THE TECHNOLOGY INDUSTRY; BUSINESS CONSULTING AND INFORMATION SERVICES; MARKETING CONSULTING; NEW BUSINESS VENTURE DEVELOPMENT AND FORMATION CONSULTING SERVICES (U.S. CLS. 100, 101 AND 102).

FIRST USE 11-0-2009; IN COMMERCE 1-0-2010.

WILLIAM BRECKENFELD, EXAMINING ATTORNEY

CLASS 35—(Continued).

SN 85-448,066. THE BRANDWARE GROUP, INC., SNELLVILLE, GA. FILED 10-14-2011.

Brandware

THE MARK CONSISTS OF STANDARD CHARACTERS WITHOUT CLAIM TO ANY PARTICULAR FONT, STYLE, SIZE, OR COLOR.

FOR ADVERTISING AND MARKETING SERVICES PROVIDED BY MEANS OF INDIRECT METHODS OF MARKETING COMMUNICATIONS, NAMELY, SOCIAL MEDIA, SEARCH ENGINE MARKETING, INQUIRY MARKETING, INTERNET MARKETING, MOBILE MARKETING, BLOGGING AND OTHER FORMS OF PASSIVE, SHARABLE OR VIRAL COMMUNICATIONS CHANNELS; MARKETING RESEARCH SERVICES; PUBLIC RELATIONS (U.S. CLS. 100, 101 AND 102).

FIRST USE 4-10-2000; IN COMMERCE 6-1-2000.
CHERYL CLAYTON, EXAMINING ATTORNEY

SN 85-448,077. INTEGRATED DISPENSING SOLUTIONS, INC., AGOURA HILLS, CA. FILED 10-14-2011.

IntelliSpense

THE MARK CONSISTS OF STANDARD CHARACTERS WITHOUT CLAIM TO ANY PARTICULAR FONT, STYLE, SIZE, OR COLOR.

FOR ON-LINE RETAIL STORE SERVICES FEATURING ASSEMBLY FLUID DISPENSING AND STORAGE EQUIPMENT (U.S. CLS. 100, 101 AND 102).

FIRST USE 4-0-2002; IN COMMERCE 4-0-2002.
CARYN GLASSER, EXAMINING ATTORNEY

SN 85-448,079. ASHDON FARMS, LLC, WAUKESHA, WI. FILED 10-14-2011.



THE MARK CONSISTS OF THE WORDS "HOPE", "SHARE", "GIVE", LOCATED FROM LEFT TO RIGHT RESPECTIVELY, WITHIN OPENINGS CREATED BY A STYLIZED DESIGN ELEMENT THAT CONSISTS OF STYLIZED PEOPLE WITH ARMS LINKED TO FORM DESIGNS OF BRIDGES AND HOUSES.

FOR ON-LINE RETAIL STORE SERVICES FEATURING PROCESSED NUTS AND NUT MIXES, CARAMEL POPCORN, TRAIL MIXES, CHOCOLATE COVERED NUTS, AND CHOCOLATE AND CARAMEL COVERED NUTS (U.S. CLS. 100, 101 AND 102).

NAPOLEON SHARMA, EXAMINING ATTORNEY

CLASS 35—(Continued).

SN 85-448,151. SLIPSTREAM COMMUNICATIONS, LLC, NEW YORK, NY. FILED 10-14-2011.

THE @ WORK STATE OF MIND

THE MARK CONSISTS OF STANDARD CHARACTERS WITHOUT CLAIM TO ANY PARTICULAR FONT, STYLE, SIZE, OR COLOR.

FOR ADVERTISING AND MARKETING (U.S. CLS. 100, 101 AND 102).

LINDA POWELL, EXAMINING ATTORNEY

SN 85-448,213. DELICIOUSNUTRITIOUS LLC, OAKLAND, CA. FILED 10-14-2011.

: D

THE MARK CONSISTS OF STANDARD CHARACTERS WITHOUT CLAIM TO ANY PARTICULAR FONT, STYLE, SIZE, OR COLOR.

FOR ON-LINE ORDERING SERVICES IN THE FIELD OF FOOD DELIVERY; ON-LINE ORDERING SERVICES IN THE FIELD OF PREMADE FOOD; ON-LINE ORDERING SERVICES IN THE FIELD OF MADE TO ORDER FOOD (U.S. CLS. 100, 101 AND 102).

FIRST USE 10-21-2010; IN COMMERCE 10-21-2010.
JAY BESCH, EXAMINING ATTORNEY

SN 85-448,220. MCHUGH & COMPANY, INC., CONCORD, MA. FILED 10-14-2011.



FOR BUSINESS MANAGEMENT CONSULTATION (U.S. CLS. 100, 101 AND 102).

MARK RADEMACHER, EXAMINING ATTORNEY

CLASS 35—(Continued).

SN 85-448,243. BLUE SURF MARKETING, INC., DBA BLUE-SURF, MARINA DEL REY, CA. FILED 10-14-2011.

Call Tracking. Simplified.

THE MARK CONSISTS OF STANDARD CHARACTERS WITHOUT CLAIM TO ANY PARTICULAR FONT, STYLE, SIZE, OR COLOR.

NO CLAIM IS MADE TO THE EXCLUSIVE RIGHT TO USE "CALL TRACKING", APART FROM THE MARK AS SHOWN.

FOR BUSINESS SERVICES, NAMELY, TRACKING AND MONITORING OF CALLS FOR OTHERS IN RESPONSE TO ADVERTISING ADS (U.S. CLS. 100, 101 AND 102).

FIRST USE 10-1-2011; IN COMMERCE 10-14-2011.
MARK RADEMACHER, EXAMINING ATTORNEY

SN 85-448,247. SUPER 1 TORRANCE, INC., DBA S.MART, LOS ANGELES, CA. FILED 10-14-2011.



THE STIPPLING IS FOR SHADING PURPOSES ONLY.
THE MARK CONSISTS OF THE LETTER "S" AND THE WORD "MART" BOTH IN BOLD AND CAPITALIZED, WITH THE WORD "MART" IN SLIGHTLY SMALLER FONT, AND WITH A SMALL FILLED IN CIRCLE BETWEEN THE LETTER "S" AND THE WORD "MART".

THE WORDING "S.MART" HAS NO MEANING IN A FOREIGN LANGUAGE.

FOR RETAIL GROCERY STORES; SUPERMARKETS (U.S. CLS. 100, 101 AND 102).

FIRST USE 10-1-2011. THE MARK WAS FIRST USED ANYWHERE IN A DIFFERENT FORM OTHER THAN THAT SOUGHT TO BE REGISTERED AT LEAST AS EARLY AS 10/01/2011; IN COMMERCE 10-1-2011, THE MARK WAS FIRST USED IN COMMERCE IN A DIFFERENT FORM OTHER THAN THAT SOUGHT TO BE REGISTERED AT LEAST AS EARLY AS 10/01/2011.

KATINA MISTER, EXAMINING ATTORNEY

CLASS 35—(Continued).

SN 85-448,347. WIKKIT LLC, NEW YORK, NY. FILED 10-15-2011.

teamSQR

THE MARK CONSISTS OF STANDARD CHARACTERS WITHOUT CLAIM TO ANY PARTICULAR FONT, STYLE, SIZE, OR COLOR.

FOR PROMOTING THE SALE OF GOODS AND SERVICES OF OTHERS BY PROVIDING A WEBSITE FEATURING COUPONS, REBATES, PRICE-COMPARISON INFORMATION, PRODUCT REVIEWS, LINKS TO THE RETAIL WEBSITES OF OTHERS, AND PROVIDING INCENTIVE AWARD PROGRAMS FOR CUSTOMERS THROUGH THE ISSUANCE AND PROCESSING OF LOYALTY COUPONS FOR FREQUENT USE OF PARTICIPATING BUSINESSES (U.S. CLS. 100, 101 AND 102).

PRISCILLA MILTON, EXAMINING ATTORNEY

SN 85-448,359. LEAVEN, LLC, CANTON, GA. FILED 10-15-2011.

Leaven

THE MARK CONSISTS OF STANDARD CHARACTERS WITHOUT CLAIM TO ANY PARTICULAR FONT, STYLE, SIZE, OR COLOR.

FOR ADVERTISING AND MARKETING (U.S. CLS. 100, 101 AND 102).

FIRST USE 5-1-2011; IN COMMERCE 5-1-2011.

ANNE FARRELL, EXAMINING ATTORNEY

SN 85-448,461. BOSTWICK, MELINDA A., ANN ARBOR, MI. FILED 10-16-2011.

Picture Me Project

THE MARK CONSISTS OF STANDARD CHARACTERS WITHOUT CLAIM TO ANY PARTICULAR FONT, STYLE, SIZE, OR COLOR.

FOR CHARITABLE SERVICES, NAMELY, ORGANIZING AND DEVELOPING PROJECTS THAT AIM TO IMPROVE THE LIVES OF UNDERPRIVILEGED AND IMPOVERISHED PEOPLE (U.S. CLS. 100, 101 AND 102).

FIRST USE 1-30-2009; IN COMMERCE 1-30-2009.

THOMAS MANOR, EXAMINING ATTORNEY

CLASS 35—(Continued).

SN 85-448,469. COORDINADORA DE FOMENTO AL COMERCIO EXTERIOR DEL ESTADO DE GUANAJUATO, LEON, GUANAJUATO, MEXICO, FILED 10-16-2011.

BAJÍOFIRST

NO CLAIM IS MADE TO THE EXCLUSIVE RIGHT TO USE "FIRST", APART FROM THE MARK AS SHOWN.

THE MARK CONSISTS OF THE WORDS "BAJIO" AND "FIRST" IN STYLIZED AND CAPITAL LETTERS WITH AN ACCENT MARK ON TOP OF LETTER "I".

THE ENGLISH TRANSLATION OF BAJIO IN THE MARK IS LOWLAND.

FOR BUSINESS ADMINISTRATION CONSULTANCY; BUSINESS MANAGEMENT CONSULTING WITH RELATION TO STRATEGY, MARKETING, PRODUCTION, PERSONNEL AND RETAIL SALE MATTERS; CONDUCTING, ARRANGING AND ORGANIZING TRADE SHOWS AND TRADE FAIRS FOR COMMERCIAL AND ADVERTISING PURPOSES; EXPORT AND IMPORT AGENCIES; INTERNATIONAL BUSINESS CONSULTING SERVICES RELATING TO IMPORT AND EXPORT OF GOODS, PRODUCTS TRADING, SERVICES PROMOTION, ADVERTISING, MARKET RESEARCH STUDIES; PROMOTION OF BUSINESS OPPORTUNITIES; SALES DEMONSTRATION (U.S. CLS. 100, 101 AND 102).
EDWARD FENNESSY, EXAMINING ATTORNEY

SN 85-448,472. COORDINADORA DE FOMENTO AL COMERCIO EXTERIOR DEL ESTADO DE GUANAJUATO, LEON, GUANAJUATO, MEXICO, FILED 10-16-2011.



THE MARK CONSISTS OF THREE RECTANGULAR SHAPES FORMING A TWO DIMENSIONAL CAPITAL LETTER H PLACED ABOVE THE WORD "HEURISTIC" IN STYLIZED LETTERS.

FOR BUSINESS ADMINISTRATION CONSULTANCY; BUSINESS MANAGEMENT CONSULTING WITH RELATION TO STRATEGY, MARKETING, PRODUCTION, PERSONNEL AND RETAIL SALE MATTERS; CONDUCTING, ARRANGING AND ORGANIZING TRADE SHOWS AND TRADE FAIRS FOR COMMERCIAL AND ADVERTISING PURPOSES; EXPORT AND IMPORT AGENCIES; INTERNATIONAL BUSINESS CONSULTING SERVICES RELATING TO IMPORT AND EXPORT OF GOODS, PRODUCTS TRADING, SERVICES PROMOTION, ADVERTISING, MARKET RESEARCH STUDIES; PROMOTION OF BUSINESS OPPORTUNITIES; SALES DEMONSTRATION (U.S. CLS. 100, 101 AND 102).
EDWARD FENNESSY, EXAMINING ATTORNEY

CLASS 35—(Continued).

SN 85-448,565. BOATHOUSE GROUP, INC., WALTHAM, MA. FILED 10-17-2011.

SPEEDBILLY

THE MARK CONSISTS OF STANDARD CHARACTERS WITHOUT CLAIM TO ANY PARTICULAR FONT, STYLE, SIZE, OR COLOR.

FOR ADVERTISING, MARKETING AND PROMOTION SERVICES; OPERATING ONLINE MARKETPLACES FOR THE SELLERS OF GOODS; PROVIDING A WEBSITE CONNECTING SELLERS OF GOODS WITH PROSPECTIVE PURCHASERS; MARKETING THE GOODS AND SERVICES OF MOTOR VEHICLE VENDORS; PROVIDING A WEBSITE WHERE THE VENDORS OF MOTOR VEHICLES MAY ADVERTISE THEIR INVENTORIES; PROVIDING A SEARCHABLE ONLINE ADVERTISING WEBSITE AND GUIDE THAT AGGREGATES AND FEATURES INFORMATION ABOUT THE GOODS AND SERVICES OF OTHER VENDORS IN THE FIELD OF MOTOR VEHICLES; PROVIDING A WEBSITE WHERE CONSUMERS MAY RESERVE THE MOTOR VEHICLES OF OTHER VENDORS FOR FURTHER CONSIDERATION AND POSSIBLE PURCHASE BY PAYMENT OF REFUNDABLE DEPOSITS (U.S. CLS. 100, 101 AND 102).

HOWARD SMIGA, EXAMINING ATTORNEY

SN 85-448,576. BAND OF OUTSIDERS, INC., LOS ANGELES, CA. FILED 10-17-2011.

Band of Outsiders

THE MARK CONSISTS OF STANDARD CHARACTERS WITHOUT CLAIM TO ANY PARTICULAR FONT, STYLE, SIZE, OR COLOR.

OWNER OF U.S. REG. NOS. 3,098,897 AND 3,602,221.
FOR RETAIL STORE AND ON-LINE RETAIL STORE SERVICES FEATURING CLOTHING, LEATHER GOODS AND ACCESSORIES (U.S. CLS. 100, 101 AND 102).
NAKIA HENRY, EXAMINING ATTORNEY

SN 85-448,612. KREUZER, CHANDRA Z., MIAMI, FL. FILED 10-17-2011.

FIRST KNOWLEDGE

THE MARK CONSISTS OF STANDARD CHARACTERS WITHOUT CLAIM TO ANY PARTICULAR FONT, STYLE, SIZE, OR COLOR.

FOR ONLINE RETAIL STORE SERVICES FEATURING EARLY CHILDHOOD AND ELEMENTARY CURRICULAR MATERIAL (U.S. CLS. 100, 101 AND 102).
CORY BOONE, EXAMINING ATTORNEY

CLASS 35—(Continued).

SN 85-448,622. WEST VIRGINIA DEPARTMENT OF COMMERCE, CHARLESTON, WV. FILED 10-17-2011.

**BUSINESS AT THE SPEED OF
LIFE**

THE MARK CONSISTS OF STANDARD CHARACTERS WITHOUT CLAIM TO ANY PARTICULAR FONT, STYLE, SIZE, OR COLOR.

FOR PROMOTING THE ECONOMIC DEVELOPMENT IN THE STATE OF WEST VIRGINIA (U.S. CLS. 100, 101 AND 102).

FIRST USE 9-30-2011; IN COMMERCE 9-30-2011.
INGA ERVIN, EXAMINING ATTORNEY

SN 85-448,662. IKASA, LLC, ORANGE, CT. FILED 10-17-2011.

IKASA

THE MARK CONSISTS OF STANDARD CHARACTERS WITHOUT CLAIM TO ANY PARTICULAR FONT, STYLE, SIZE, OR COLOR.

FOR RETAIL STORE AND ON-LINE RETAIL STORE SERVICES FEATURING FURNITURE (U.S. CLS. 100, 101 AND 102).

HANNO RITTNER, EXAMINING ATTORNEY

SN 85-448,707. BENICE, STACI, COLUMBUS, GA. AND THOMAS, MARDEE, COLUMBUS, GA. FILED 10-17-2011.

The Intense Fork

THE MARK CONSISTS OF STANDARD CHARACTERS WITHOUT CLAIM TO ANY PARTICULAR FONT, STYLE, SIZE, OR COLOR.

FOR RETAIL STORE SERVICES FEATURING FOOD (U.S. CLS. 100, 101 AND 102).

MYRIAH HABEEB, EXAMINING ATTORNEY

CLASS 35—(Continued).

SN 85-448,822. PRATIMA RAWAL, KENSAL GREEN, LONDON, UNITED KINGDOM, FILED 10-17-2011.

SIMPLYNAS

THE MARK CONSISTS OF STANDARD CHARACTERS WITHOUT CLAIM TO ANY PARTICULAR FONT, STYLE, SIZE, OR COLOR.

FOR ON-LINE RETAIL STORE SERVICES FEATURING NETWORKED DATA STORAGE, ELECTRONIC STORAGE AND COMPUTER DATA STORAGE (U.S. CLS. 100, 101 AND 102).

FIRST USE 7-23-2010; IN COMMERCE 7-23-2010.
CARYN GLASSER, EXAMINING ATTORNEY

SN 85-448,937. LITTLE BLACK BAG, INC., LOS ANGELES, CA. FILED 10-17-2011.

LITTLE BLACK BAG

THE MARK CONSISTS OF STANDARD CHARACTERS WITHOUT CLAIM TO ANY PARTICULAR FONT, STYLE, SIZE, OR COLOR.

FOR ON-LINE RETAIL STORE SERVICES FEATURING A WIDE VARIETY OF CONSUMER GOODS OF OTHERS, AND PROVIDING A WEBSITE FACILITATING THE TRADING OF GIFTS (U.S. CLS. 100, 101 AND 102).

FIRST USE 9-24-2011; IN COMMERCE 9-24-2011.
TARAH HARDY, EXAMINING ATTORNEY

SN 85-448,959. GET HEALTHY, LLC, PHILADELPHIA, PA. FILED 10-17-2011.

Get Healthy

THE MARK CONSISTS OF STANDARD CHARACTERS WITHOUT CLAIM TO ANY PARTICULAR FONT, STYLE, SIZE, OR COLOR.

FOR RETAIL STORE AND ON-LINE RETAIL STORE SERVICES FEATURING VITAMINS, NUTRITIONAL SUPPLEMENTS, HEALTH FOODS AND HEALTH PRODUCTS (U.S. CLS. 100, 101 AND 102).

FIRST USE 10-5-2011; IN COMMERCE 10-5-2011.
DAWN FELDMAN, EXAMINING ATTORNEY

CLASS 35—(Continued).

SN 85-449,123. TAXKEEPING, LLC, CINCINNATI, OH.
FILED 10-17-2011.



NO CLAIM IS MADE TO THE EXCLUSIVE RIGHT TO USE "LLC", APART FROM THE MARK AS SHOWN.

THE COLOR(S) RED, BLUE, ROSE, SKY BLUE IS/ARE CLAIMED AS A FEATURE OF THE MARK.

THE MARK CONSISTS OF THE WORD "TAXKEEPING" WITH AN UPPERCASE "T" AND "K" IN RED AND OTHER LETTERS LOWERCASE IN RED, ONE RIGHT POINTING CURVED LINE IN SKY BLUE, ONE LEFT POINTING CURVED LINE IN ROSE, AND ONE LARGER LEFT POINTING CURVED LINE IN SKY BLUE HAVING POINTS ENCOMPASSING THE OTHER TWO CURVED LINES AT THE TOP. THE LETTERING "LLC" APPEARS IN BLUE IN THE LOWER RIGHT PORTION OF THE MARK.

FOR BOOKKEEPING; TAX FILING SERVICES; TAX PREPARATION (U.S. CLS. 100, 101 AND 102).

FIRST USE 8-14-2011; IN COMMERCE 10-5-2011.

JORDAN BAKER, EXAMINING ATTORNEY

SN 85-449,152. SEARS BRANDS, LLC, HOFFMAN ESTATES, IL. FILED 10-17-2011.

WORK WHAT YOU GOT

THE MARK CONSISTS OF STANDARD CHARACTERS WITHOUT CLAIM TO ANY PARTICULAR FONT, STYLE, SIZE, OR COLOR.

FOR RETAIL DEPARTMENT STORE SERVICES AND ONLINE RETAIL DEPARTMENT STORE SERVICES (U.S. CLS. 100, 101 AND 102).

FIRST USE 9-0-2011; IN COMMERCE 9-0-2011.

HEATHER BIDDULPH, EXAMINING ATTORNEY

SN 85-449,160. SEARS BRANDS, LLC, HOFFMAN ESTATES, IL. FILED 10-17-2011.

APROVECHA LO QUE TIENES

THE MARK CONSISTS OF STANDARD CHARACTERS WITHOUT CLAIM TO ANY PARTICULAR FONT, STYLE, SIZE, OR COLOR.

THE ENGLISH TRANSLATION OF "APROVECHA LO QUE TIENES" IN THE MARK IS "USE WHAT YOU HAVE".

FOR RETAIL DEPARTMENT STORE SERVICES AND ONLINE RETAIL DEPARTMENT STORE SERVICES (U.S. CLS. 100, 101 AND 102).

FIRST USE 9-0-2011; IN COMMERCE 9-0-2011.

HEATHER BIDDULPH, EXAMINING ATTORNEY

CLASS 35—(Continued).

SN 85-449,192. ISSIO SOLUTIONS, INC., LAFAYETTE, CA.
FILED 10-17-2011.

ISSIO SOLUTIONS

THE MARK CONSISTS OF STANDARD CHARACTERS WITHOUT CLAIM TO ANY PARTICULAR FONT, STYLE, SIZE, OR COLOR.

NO CLAIM IS MADE TO THE EXCLUSIVE RIGHT TO USE "SOLUTIONS", APART FROM THE MARK AS SHOWN.

FOR PHYSICIAN PRACTICE AND MEDICAL PRACTICE MANAGEMENT FOR OTHERS; COMPUTERIZED DATABASE MANAGEMENT IN THE FIELDS OF MEDICAL RECORDS AND MEDICAL BILLING; ONLINE BUSINESS AND FINANCIAL RECORDS MANAGEMENT IN THE FIELDS OF MEDICAL RECORDS AND MEDICAL BILLING; FINANCIAL RECORDS MANAGEMENT, NAMELY, REVENUE MANAGEMENT SERVICES FOR PHYSICIAN PRACTICES AND MEDICAL PRACTICES (U.S. CLS. 100, 101 AND 102).

JANET LEE, EXAMINING ATTORNEY

SN 85-449,215. BRANDTUITIVE, INC., NEW YORK, NY.
FILED 10-17-2011.

BRANDTUITIVE

THE MARK CONSISTS OF STANDARD CHARACTERS WITHOUT CLAIM TO ANY PARTICULAR FONT, STYLE, SIZE, OR COLOR.

FOR MARKETING AND BRANDING SERVICES, NAMELY: CONSULTATION REGARDING THE DEVELOPMENT OF MARKETING AND COMMUNICATION PROGRAMS; DEVELOPMENT AND IMPLEMENTATION OF BRANDING AND CORPORATE IDENTITY STRATEGIES; DEVELOPMENT OF ADVERTISEMENTS AND COMMERCIAL ANNOUNCEMENTS (U.S. CLS. 100, 101 AND 102).

FIRST USE 1-7-2011; IN COMMERCE 1-7-2011.

JENNIFER VASQUEZ, EXAMINING ATTORNEY

CLASS 35—(Continued).

SN 85-449,226. ISSIO SOLUTIONS, INC., LAFAYETTE, CA. FILED 10-17-2011.



NO CLAIM IS MADE TO THE EXCLUSIVE RIGHT TO USE "SOLUTIONS", APART FROM THE MARK AS SHOWN.

THE COLOR(S) BLUE, AQUA AND BLACK IS/ARE CLAIMED AS A FEATURE OF THE MARK.

THE MARK CONSISTS OF THE WORD "ISSIO" IN BLACK LETTERS, OTHER THAN A BLUE INITIAL "I" AND AN AQUA SECOND "I", AND WITH DOTS CONNECTING THE TWO "I" LETTERS IN SHADES BETWEEN BLUE AND AQUA, ALL ABOVE THE WORD "SOLUTIONS" ALL IN BLACK LETTERS.

FOR PHYSICIAN PRACTICE AND MEDICAL PRACTICE MANAGEMENT FOR OTHERS; COMPUTERIZED DATABASE MANAGEMENT IN THE FIELDS OF MEDICAL RECORDS AND MEDICAL BILLING; ONLINE BUSINESS AND FINANCIAL RECORDS MANAGEMENT IN THE FIELDS OF MEDICAL RECORDS AND MEDICAL BILLING; FINANCIAL RECORDS MANAGEMENT, NAMELY, REVENUE MANAGEMENT SERVICES FOR PHYSICIAN PRACTICES AND MEDICAL PRACTICES (U.S. CLS. 100, 101 AND 102).
JANET LEE, EXAMINING ATTORNEY

SN 85-449,254. INDUSTRIE DENIM, LLC, LOS ANGELES, CA. FILED 10-17-2011.

IDENIM

THE MARK CONSISTS OF STANDARD CHARACTERS WITHOUT CLAIM TO ANY PARTICULAR FONT, STYLE, SIZE, OR COLOR.

FOR RETAIL STORE AND ON-LINE RETAIL STORE SERVICES FEATURING CLOTHING, HEADWEAR, FOOTWEAR, JEWELRY, FASHION ACCESSORIES, AND SMALL LEATHER GOODS (U.S. CLS. 100, 101 AND 102).

JOHN GARTNER, EXAMINING ATTORNEY

CLASS 35—(Continued).

SN 85-449,261. SHI-PING WANG, SOUTH EL MONTE, CA. FILED 10-17-2011.

移民樂

THE MARK CONSISTS OF CHINESE CHARACTERS. THE NON-LATIN CHARACTERS IN THE MARK TRANSLITERATE TO "YI MIN LE" AND THIS MEANS "IMMIGRANT HAPPINESS" IN ENGLISH.

FOR RETAIL FURNITURE STORES; RETAIL STORE SERVICES FEATURING APPLIANCES AND HOUSEWARES; SECOND HAND DEALERSHIPS FEATURING FURNITURE (U.S. CLS. 100, 101 AND 102).

FIRST USE 3-0-1996; IN COMMERCE 3-0-1996.

JOHN GARTNER, EXAMINING ATTORNEY

SN 85-449,387. THAT WAS THEN ENTERPRISES, LOS ANGELES, CA. FILED 10-17-2011.

SHORTCUT TO DELICIOUS

THE MARK CONSISTS OF STANDARD CHARACTERS WITHOUT CLAIM TO ANY PARTICULAR FONT, STYLE, SIZE, OR COLOR.

FOR ONLINE RETAIL STORE SERVICES FEATURING FOOD PRODUCTS (U.S. CLS. 100, 101 AND 102).

WENDY JUN, EXAMINING ATTORNEY

SN 85-449,425. BUCHHOLTZ, MARTIN K. AKA ADAMS, MARTIN, MIDDLETOWN, CA. FILED 10-18-2011.

UNITISM

THE MARK CONSISTS OF STANDARD CHARACTERS WITHOUT CLAIM TO ANY PARTICULAR FONT, STYLE, SIZE, OR COLOR.

FOR CONSULTING SERVICES IN THE AREA OF SUSTAINABLE BUSINESS SOLUTIONS; ECONOMIC FORECASTING AND ANALYSIS; PROGNOSIS ON ECONOMIC AFFAIRS; PROMOTING PUBLIC AWARENESS IN THE FIELD OF SOCIAL WELFARE; PROVIDING INFORMATION AND ANALYSIS IN THE FIELDS OF ECONOMICS AND BUSINESS; PROVIDING INFORMATION IN THE FIELD OF ECONOMICS; RESEARCH AND ANALYSIS IN THE FIELDS OF ECONOMICS AND ECONOMIC POLICY (U.S. CLS. 100, 101 AND 102).

FIRST USE 10-11-2011; IN COMMERCE 10-11-2011.

JULIE VEPPUMTHARA, EXAMINING ATTORNEY

CLASS 35—(Continued).

SN 85-449,438. CREATION ENGINE, INC., MOUNTAIN VIEW, CA. FILED 10-18-2011.

CREATION ENGINE

THE MARK CONSISTS OF STANDARD CHARACTERS WITHOUT CLAIM TO ANY PARTICULAR FONT, STYLE, SIZE, OR COLOR.

FOR ONLINE RETAIL STORES SERVICES FEATURING COMPUTER HARDWARE AND SOFTWARE; MAIL ORDER SERVICES FEATURING COMPUTER HARDWARE AND SOFTWARE (U.S. CLS. 100, 101 AND 102).

FIRST USE 3-1-1994; IN COMMERCE 3-1-1994.
COURTNEY ALVAREZ, EXAMINING ATTORNEY

CLASS 35—(Continued).

SN 85-449,603. SETH DAVID NEEDELMAN, DBA EVONATIONAL, FREDERICK, MD. FILED 10-18-2011.

EVOnational

THE MARK CONSISTS OF STANDARD CHARACTERS WITHOUT CLAIM TO ANY PARTICULAR FONT, STYLE, SIZE, OR COLOR.

FOR DATA MANAGEMENT SERVICES FOR USE IN WORKERS COMPENSATION CLAIMS MANAGEMENT, NAMELY, ELECTRONIC DATA COLLECTION AND ONLINE CLAIMS MANAGEMENT (U.S. CLS. 100, 101 AND 102).

FIRST USE 7-1-2011; IN COMMERCE 7-1-2011.
EMILY CHUO, EXAMINING ATTORNEY

SN 85-449,453. SELF MOTIVATED ATHLETIC AGENCY, LANGHORNE, PA. FILED 10-18-2011.

DREAM BIG ACHIEVE BIGGER

THE MARK CONSISTS OF STANDARD CHARACTERS WITHOUT CLAIM TO ANY PARTICULAR FONT, STYLE, SIZE, OR COLOR.

FOR TALENT AGENCY SERVICES (U.S. CLS. 100, 101 AND 102).

WILLIAM VERHOSEK, EXAMINING ATTORNEY

SN 85-449,645. TJM FARMS, LLC, PALOS HEIGHTS, IL. AND TJM FARMS, LLC, PALOS HEIGHTS, IL. FILED 10-18-2011.

EMYCONDO

THE MARK CONSISTS OF STANDARD CHARACTERS WITHOUT CLAIM TO ANY PARTICULAR FONT, STYLE, SIZE, OR COLOR.

FOR REAL ESTATE MARKETING SERVICES IN THE FIELD OF ATTACHED HOUSING (U.S. CLS. 100, 101 AND 102).

LINDA MICKLEBURGH, EXAMINING ATTORNEY

SN 85-449,553. TIME WARNER GLOBAL MEDIA GROUP INC., NEW YORK, NY. FILED 10-18-2011.

WHY I AM

THE MARK CONSISTS OF STANDARD CHARACTERS WITHOUT CLAIM TO ANY PARTICULAR FONT, STYLE, SIZE, OR COLOR.

FOR ADVERTISING SERVICES, NAMELY, PROMOTING THE BRANDS, GOODS AND SERVICES OF OTHERS THROUGH STORIES OF PERSONAL STRENGTH AND TRIUMPH (U.S. CLS. 100, 101 AND 102).

APRIL ROACH, EXAMINING ATTORNEY

SN 85-449,679. LAB CONSULTING PARTNERSHIP, INC., HOUSTON, TX. FILED 10-18-2011.

Non-Technology Improvement

THE MARK CONSISTS OF STANDARD CHARACTERS WITHOUT CLAIM TO ANY PARTICULAR FONT, STYLE, SIZE, OR COLOR.

FOR BUSINESS CONSULTING SERVICES; BUSINESS CONSULTING SERVICES IN THE NATURE OF BUSINESS OPERATIONS CONSULTING; BUSINESS MANAGEMENT CONSULTING (U.S. CLS. 100, 101 AND 102).

FIRST USE 7-1-2008; IN COMMERCE 7-1-2008.
DAVID MURRAY, EXAMINING ATTORNEY

CLASS 35—(Continued).

SN 85-449,691. LAB CONSULTING PARTNERSHIP, INC., HOUSTON, TX. FILED 10-18-2011.

Virtuous Waste

THE MARK CONSISTS OF STANDARD CHARACTERS WITHOUT CLAIM TO ANY PARTICULAR FONT, STYLE, SIZE, OR COLOR.

FOR BUSINESS CONSULTING SERVICES; BUSINESS CONSULTING SERVICES IN THE NATURE OF BUSINESS OPERATIONS CONSULTING; BUSINESS MANAGEMENT CONSULTING (U.S. CLS. 100, 101 AND 102).
FIRST USE 3-1-2007; IN COMMERCE 3-1-2007.
DAVID MURRAY, EXAMINING ATTORNEY

SN 85-449,700. LAB CONSULTING PARTNERSHIP, INC., HOUSTON, TX. FILED 10-18-2011.



OWNER OF U.S. REG. NO. 3,075,993.
THE MARK CONSISTS OF THE WORDS, "THE LAB" IN CAPITAL LETTERS "NON-TECHNOLOGY IMPROVEMENT" DIRECTLY BELOW "THE LAB" AND VERTICAL BARS INCREASING IN LENGTH TO THE LEFT.
FOR BUSINESS CONSULTING SERVICES; BUSINESS CONSULTING SERVICES IN THE NATURE OF BUSINESS OPERATIONS CONSULTING; BUSINESS MANAGEMENT CONSULTING (U.S. CLS. 100, 101 AND 102).
FIRST USE 7-1-2008; IN COMMERCE 7-1-2008.
DAVID MURRAY, EXAMINING ATTORNEY

SN 85-449,734. BRIGHTEDGE TECHNOLOGIES, INC., SAN MATEO, CA. FILED 10-18-2011.

Sites.Search.Social.

THE MARK CONSISTS OF STANDARD CHARACTERS WITHOUT CLAIM TO ANY PARTICULAR FONT, STYLE, SIZE, OR COLOR.

FOR ON-LINE ADVERTISING AND MARKETING SERVICES; MARKETING SERVICES, NAMELY, TRACKING AND ASSESSING CUMULATIVE INTERACTIONS BETWEEN COMPANIES AND CUSTOMERS (U.S. CLS. 100, 101 AND 102).
DOMINIC J. FERRAIUOLO, EXAMINING ATTORNEY

CLASS 35—(Continued).

SN 85-449,758. BRIGHTEDGE TECHNOLOGIES, INC., SAN MATEO, CA. FILED 10-18-2011.

SIGNAL STREAM

THE MARK CONSISTS OF STANDARD CHARACTERS WITHOUT CLAIM TO ANY PARTICULAR FONT, STYLE, SIZE, OR COLOR.

FOR ON-LINE ADVERTISING AND MARKETING SERVICES; MARKETING SERVICES, NAMELY, ANALYZING THE SUM OF CUSTOMER ACTIVITIES ON THE INTERNET, INCLUDING VISITS TO WEB PAGES, INTERNET SEARCHES AND NETWORKING INTERACTIONS (U.S. CLS. 100, 101 AND 102).
DOMINIC J. FERRAIUOLO, EXAMINING ATTORNEY

SN 85-449,833. TORY ROAD LLC, PARK CITY, UT. FILED 10-18-2011.

NO MORE BEDLESS PETS

THE MARK CONSISTS OF STANDARD CHARACTERS WITHOUT CLAIM TO ANY PARTICULAR FONT, STYLE, SIZE, OR COLOR.

FOR COMPUTERIZED ON-LINE RETAIL STORE SERVICES FEATURING PET BEDS, CAT SCRATCHING POSTS, DOG BOWLS, PET CARRIERS AND CRATES (U.S. CLS. 100, 101 AND 102).
FIRST USE 6-28-2011; IN COMMERCE 6-28-2011.
RENEE MCCRAY, EXAMINING ATTORNEY

SN 85-449,849. LSN, INC., ATLANTA, GA. FILED 10-18-2011.

TXT2VOTE

THE MARK CONSISTS OF STANDARD CHARACTERS WITHOUT CLAIM TO ANY PARTICULAR FONT, STYLE, SIZE, OR COLOR.

OWNER OF U.S. REG. NO. 3,300,276.
SEC. 2(F).
FOR DESIGNING AND CREATING PROMOTIONAL CAMPAIGNS FOR ADVERTISERS TO MEASURE CONSUMER RESPONSES BY VOTING THROUGH THE USE OF WIRELESS TEXT MESSAGING SERVICES (U.S. CLS. 100, 101 AND 102).
FIRST USE 12-20-2005; IN COMMERCE 12-20-2005.
SHAILA SETTLES, EXAMINING ATTORNEY

CLASS 35—(Continued).

SN 85-449,861. HOFFMAN, JEFF, TEMPE, AZ. FILED 10-18-2011.

GIVE GOOD

THE MARK CONSISTS OF STANDARD CHARACTERS WITHOUT CLAIM TO ANY PARTICULAR FONT, STYLE, SIZE, OR COLOR.

FOR PROMOTIONAL SERVICES, NAMELY, PROMOTING THE GOODS OF OTHERS BY MEANS OF PROVIDING ONLINE GIFT CARDS; PROMOTIONAL SERVICES, NAMELY, PROMOTING THE GOODS OF OTHERS BY MEANS OF PROVIDING ONLINE GIFT CERTIFICATES; PROMOTIONAL SERVICES, NAMELY, PROMOTING THE GOODS OF OTHERS BY PROVIDING APPAREL, PROMOTIONAL PRODUCTS, GIFTS, PRINTING, CHARITABLE GOODS, AND ADVERTISING SPECIALTIES (U.S. CLS. 100, 101 AND 102).

JAY FLOWERS, EXAMINING ATTORNEY

SN 85-449,868. ECHOED INC., GREAT NECK, NY. FILED 10-18-2011.

Echoed

THE MARK CONSISTS OF STANDARD CHARACTERS WITHOUT CLAIM TO ANY PARTICULAR FONT, STYLE, SIZE, OR COLOR.

FOR ONLINE ADVERTISING AND PROMOTION OF RETAILERS' PRODUCTS AND SERVICES THROUGH SOCIAL NETWORKS AND WORD-OF-MOUTH; PROVIDING STATISTICAL EVALUATION AND MEASUREMENT OF EFFECTIVENESS OF ADVERTISING; PROVIDING INCENTIVE AWARD PROGRAMS TO CUSTOMERS THROUGH RETROACTIVE CREDITS ON THEIR PURCHASES OF GOODS AND SERVICES (U.S. CLS. 100, 101 AND 102).

FIRST USE 10-10-2011; IN COMMERCE 10-10-2011.

JOHN HWANG, EXAMINING ATTORNEY

CLASS 35—(Continued).

SN 85-449,887. STRATEGIC MARKETING, INC., PALM BEACH GARDENS, FL. FILED 10-18-2011.

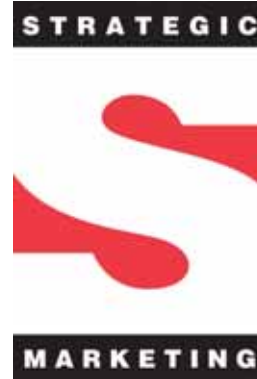

NO CLAIM IS MADE TO THE EXCLUSIVE RIGHT TO USE "STRATEGIC MARKETING", APART FROM THE MARK AS SHOWN.

THE COLOR(S) RED, WHITE AND BLACK IS/ARE CLAIMED AS A FEATURE OF THE MARK.

THE MARK CONSISTS OF THE LETTER "S" IN WHITE, WITH THE NEGATIVE SPACE SURROUNDING THE "S" IN RED, AND A BLACK BAR ABOVE AND BELOW THE "S", AND THE WORD "STRATEGIC" ABOVE THE "S" AND THE WORD "MARKETING" BELOW THE "S" IN WHITE.

FOR ADVERTISING, MARKETING AND PROMOTIONAL SERVICES, BUSINESS MARKETING, CONSULTING SERVICES, PUBLIC RELATIONS, BUSINESS MANAGEMENT SERVICES, PROCURING OF CONTRACTS FOR THE PURCHASE AND SALE OF GOODS AND SERVICES, PREPARING AND PUBLISHING ADVERTISEMENTS FOR OTHERS, DESIGN OF ADVERTISING MATERIALS FOR OTHERS, PROVIDING ADVERTISING, MARKETING AND PROMOTIONAL SERVICES FOR PRINT, DIRECT MAIL, TELEVISION, RADIO AND OTHER MEDIA (U.S. CLS. 100, 101 AND 102).

FIRST USE 1-1-1996; IN COMMERCE 1-1-1996.

JOHN WILKE, EXAMINING ATTORNEY

SN 85-449,898. ANNCO, INC., NEW YORK, NY. FILED 10-18-2011.

LOFT GIRLS' NIGHT IN

THE MARK CONSISTS OF STANDARD CHARACTERS WITHOUT CLAIM TO ANY PARTICULAR FONT, STYLE, SIZE, OR COLOR.

OWNER OF U.S. REG. NO. 3,359,615.
FOR ON-LINE AND IN STORE RETAIL STORE SERVICES IN THE FIELDS OF CLOTHING, FOOTWEAR, HANDBAGS, SMALL LEATHER ACCESSORIES, TOILETRIES, CONSUMABLE BATH PRODUCTS AND COSMETIC PRODUCTS (U.S. CLS. 100, 101 AND 102).

JAY FLOWERS, EXAMINING ATTORNEY

CLASS 35—(Continued).

SN 85-449,915. THE B&F SYSTEM, INC., DALLAS, TX.
FILED 10-18-2011.

THE WHOLESALE GIANT

THE MARK CONSISTS OF STANDARD CHARACTERS WITHOUT CLAIM TO ANY PARTICULAR FONT, STYLE, SIZE, OR COLOR.

NO CLAIM IS MADE TO THE EXCLUSIVE RIGHT TO USE "WHOLESALE", APART FROM THE MARK AS SHOWN.

FOR WHOLESALE-ONLY STORE SERVICES FEATURING GENERAL MERCHANDISE; ON-LINE WHOLESALE-ONLY STORE SERVICES FEATURING GENERAL MERCHANDISE (U.S. CLS. 100, 101 AND 102).

FIRST USE 2-0-2002; IN COMMERCE 2-0-2002.
JORDAN BAKER, EXAMINING ATTORNEY

CLASS 35—(Continued).

SN 85-450,005. IMMORTOLOGY, LLC, CHAPEL HILL, NC.
FILED 10-18-2011.

IMMORTOLOGY

THE MARK CONSISTS OF STANDARD CHARACTERS WITHOUT CLAIM TO ANY PARTICULAR FONT, STYLE, SIZE, OR COLOR.

FOR ADVERTISING, MARKETING AND PROMOTION SERVICES; BRANDING SERVICES, NAMELY, CONSULTING, DEVELOPMENT, MANAGEMENT AND MARKETING OF BRANDS FOR BUSINESSES; PROVIDING CONSULTING SERVICES IN THE FIELD OF FACILITATING THE PLANNING, BUYING, AND SELLING OF MEDIA; PUBLIC RELATIONS; SOCIAL MEDIA STRATEGY AND MARKETING CONSULTANCY FOCUSING ON HELPING CLIENTS CREATE AND EXTEND THEIR PRODUCT AND BRAND STRATEGIES BY BUILDING VIRALLY ENGAGING MARKETING SOLUTIONS (U.S. CLS. 100, 101 AND 102).

TEJBIR SINGH, EXAMINING ATTORNEY

SN 85-449,945. ERYN L. TAYLOR, CASTLE ROCK, CO.
FILED 10-18-2011.

Bite Me Colorado

THE MARK CONSISTS OF STANDARD CHARACTERS WITHOUT CLAIM TO ANY PARTICULAR FONT, STYLE, SIZE, OR COLOR.

NO CLAIM IS MADE TO THE EXCLUSIVE RIGHT TO USE "COLORADO", APART FROM THE MARK AS SHOWN.

FOR ADVERTISING AND PROMOTION SERVICES AND RELATED CONSULTING; ADVERTISING, MARKETING AND PROMOTION SERVICES; PUBLIC ADVOCACY TO PROMOTE AWARENESS OF FISHING IN COLORADO (U.S. CLS. 100, 101 AND 102).

FIRST USE 8-1-2011; IN COMMERCE 8-1-2011.
CARRIE GENOVESE, EXAMINING ATTORNEY

SN 85-450,068. SCENIC HUDSON, INC., POUGHKEEPSIE, NY. FILED 10-18-2011.



NO CLAIM IS MADE TO THE EXCLUSIVE RIGHT TO USE "HUDSON", APART FROM THE MARK AS SHOWN.

THE MARK CONSISTS OF SHADED DRAWING OF TWO MOUNTAINS, THE FIRST, LARGER MOUNTAIN PLACED IN THE UPPER LEFT SIDE OF THE DRAWING IN A

CLASS 35—(Continued).

RECTANGLE; THE SECOND SMALLER MOUNTAIN PLACED TO THE RIGHT AND SLIGHTLY BELOW THE FIRST MOUNTAIN IN AN OVERLAPPING RECTANGLE; THE SPACE BETWEEN THE TWO MOUNTAINS IS WIDER AT THE TOP AND BOTTOM OF THE DRAWING, AND NARROWS IN THE MIDDLE TO CREATE THE IMAGE OF A RIVER. BENEATH THE DRAWING ARE THE WORDS "SCENIC" AND "HUDSON", PRINTED IN CAPITAL LETTERS, WITH THE WORD "SCENIC" PRINTED ABOVE THE WORD "HUDSON".

FOR PROMOTING PUBLIC AWARENESS OF ISSUES RELATED TO LAND CONSERVATION, REGULATION AND MANAGEMENT, ENVIRONMENTAL ISSUES RELATED THERETO, AND HISTORIC PRESERVATION OF THE HUDSON RIVER VALLEY; LOBBYING SERVICES, NAMELY, PROMOTING THE INTERESTS OF LAND CONSERVATION, REGULATION AND MANAGEMENT, ENVIRONMENTAL ISSUES RELATED THERETO AND HISTORIC PRESERVATION OF THE HUDSON RIVER VALLEY IN LEGISLATIVE AND REGULATORY FIELDS; ARRANGING AND CONDUCTING BUSINESS CONFERENCES ON LAND CONSERVATION, ENVIRONMENTAL ADVOCACY, LAND USE, REGULATION AND MANAGEMENT AND HISTORIC PRESERVATION OF THE HUDSON RIVER VALLEY; ADMINISTERING AND MANAGING GRANT PROGRAMS FOR LAND CONSERVATION, MANAGEMENT AND PUBLIC USE OF LAND IN THE HUDSON RIVER VALLEY (U.S. CLS. 100, 101 AND 102).

FIRST USE 10-1-1980; IN COMMERCE 10-1-1980.
KAREN K. BUSH, EXAMINING ATTORNEY

SN 85-450,178. PEAK HEALTH SOLUTIONS, INC., SAN DIEGO, CA. FILED 10-18-2011.



NO CLAIM IS MADE TO THE EXCLUSIVE RIGHT TO USE "TECHNOLOGY" OR "HEALTH SOLUTIONS", APART FROM THE MARK AS SHOWN.

THE COLOR(S) LIGHT BLUE, DARK BLUE, ORANGE, AND DARK GREY IS/ARE CLAIMED AS A FEATURE OF THE MARK.

THE MARK CONSISTS OF THE DESIGN OF TWO TRIANGLES, ONE IN ORANGE AND THE OTHER IN LIGHT BLUE SEPARATED BY A STRAIGHT DIAGONAL WHITE LINE, AND A THIRD TRIANGLE IN DARK BLUE INTERSECTING AND SUPERIMPOSED OVER THE TWO TRIANGLES, ALL TO THE LEFT OF THE WORD "PEAK" IN DARK GRAY, OVER THE WORDS "PEOPLE TECHNOLOGY RESULTS" IN ORANGE WITH EACH WORD SEPARATED BY A SHORT VERTICAL ORANGE LINE, OVER THE WORDS "HEALTH SOLUTIONS" IN DARK GRAY.

FOR BUSINESS INFORMATION MANAGEMENT SERVICES, NAMELY, PROCEDURE AND MEDICATION CODING, BUSINESS AUDITING, AND MONITORING COMPLIANCE OF INSURANCE CLAIMS REGULATIONS AND FINANCIAL RECORD KEEPING FOR HEALTHCARE FACILITIES, HEALTHCARE ORGANIZATIONS AND HEALTH INSURANCE PLANS (U.S. CLS. 100, 101 AND 102).

FIRST USE 1-1-2011; IN COMMERCE 1-1-2011.
BARBARA A. GOLD, EXAMINING ATTORNEY

CLASS 35—(Continued).

SN 85-450,231. ROCKETSPACE INC, SAN FRANCISCO, CA. FILED S.R. 10-18-2011; AM. P.R. 2-7-2012.

RocketSpace

THE MARK CONSISTS OF STANDARD CHARACTERS WITHOUT CLAIM TO ANY PARTICULAR FONT, STYLE, SIZE, OR COLOR.

FOR INCUBATION SERVICES, NAMELY, PROVIDING WORK SPACE CONTAINING BUSINESS EQUIPMENT TO FREELANCERS, START-UPS, EXISTING BUSINESSES AND NON-PROFITS (U.S. CLS. 100, 101 AND 102).

FIRST USE 1-24-2011; IN COMMERCE 1-24-2011.
DOUGLAS LEE, EXAMINING ATTORNEY

SN 85-450,295. 9GLOBAL, INC., SAN BRUNO, CA. FILED 10-18-2011.

NOW PAYDAY

THE MARK CONSISTS OF STANDARD CHARACTERS WITHOUT CLAIM TO ANY PARTICULAR FONT, STYLE, SIZE, OR COLOR.

FOR BUSINESS ADVICE AND INFORMATION RELATING TO LOANS, FINANCE AND CAPITAL (U.S. CLS. 100, 101 AND 102).

FIRST USE 1-1-2011; IN COMMERCE 1-1-2011.
TINA MAI, EXAMINING ATTORNEY

SN 85-450,408. LAUTMAN, KARL, LOS ANGELES, CA. FILED 10-18-2011.

zabosu

THE MARK CONSISTS OF STANDARD CHARACTERS WITHOUT CLAIM TO ANY PARTICULAR FONT, STYLE, SIZE, OR COLOR.

FOR PROVIDING A WEBSITE FEATURING AN ONLINE MARKETPLACE FOR EXCHANGING GOODS AND SERVICES WITH OTHER USERS (U.S. CLS. 100, 101 AND 102).

ANDREA HACK, EXAMINING ATTORNEY

CLASS 35—(Continued).

SN 85-450,427. SPORTFOLIO & MEDIA DESIGN, LLC, FORT WORTH, TX. FILED 10-18-2011.

SPORTFOLIO

THE MARK CONSISTS OF THE STYLIZED TEXT "SPORTFOLIO".

FOR ONLINE RESUME PREPARATION SERVICES, NAMELY, CREATING ONLINE, NON-DOWNLOADABLE RESUMES AND PROFILES THAT ARE USED TO FEATURE A PARTICULAR ATHLETE'S BIOGRAPHY, ACADEMIC STATUS, STATISTICAL DATA, AND MEDIA RELATING TO AN ATHLETE'S CAREER, EDUCATION, SKILL LEVEL, AND ATHLETIC ABILITY, FOR THE PURPOSE OF PROMOTING THE ATHLETE'S ACHIEVEMENT AND SKILLS FOR PROSPECTIVE SCHOOLS AND EMPLOYERS; ONLINE RESUME PREPARATION SERVICES, NAMELY, CREATING ONLINE, NON-DOWNLOADABLE RESUMES AND PROFILES THAT ARE USED TO FEATURE A PARTICULAR SPORTS COACH OR SPORTS ADMINISTRATOR'S PREVIOUS EMPLOYMENT, EXPERIENCE, AND EDUCATION THROUGH REPRESENTATIVE WORK, NAMELY, BIOGRAPHY, COACHING VIDEOS, AND MEDIA RELATING TO EXPERTISE IN THE SPORTS INDUSTRY (U.S. CLS. 100, 101 AND 102).

FIRST USE 9-25-2011; IN COMMERCE 9-25-2011.
ALEXANDER L. POWERS, EXAMINING ATTORNEY

SN 85-450,473. GILLETT, KATHRYN J., DBA KATHRYN GILLETT, SHORELINE, WA. FILED 10-18-2011.

The hero method

THE MARK CONSISTS OF STANDARD CHARACTERS WITHOUT CLAIM TO ANY PARTICULAR FONT, STYLE, SIZE, OR COLOR.

NO CLAIM IS MADE TO THE EXCLUSIVE RIGHT TO USE "METHOD", APART FROM THE MARK AS SHOWN.

FOR CONSULTATION SERVICES, NAMELY, CREATIVE AND STRATEGIC CONSULTATION REGARDING DEVELOPMENT AND PRODUCTION OF MARKETING CAMPAIGNS FOR OTHERS (U.S. CLS. 100, 101 AND 102).

FIRST USE 8-1-2011; IN COMMERCE 8-1-2011.
APRIL HESIK, EXAMINING ATTORNEY

CLASS 35—(Continued).

SN 85-450,491. HEAVENLY TREASURES, GLENDORA, CA. FILED 10-18-2011.

MAKER TO MARKET

THE MARK CONSISTS OF STANDARD CHARACTERS WITHOUT CLAIM TO ANY PARTICULAR FONT, STYLE, SIZE, OR COLOR.

FOR RETAIL STORE SERVICES, COMPUTERIZED ON-LINE RETAIL STORE SERVICES AND MAIL ORDER SERVICES FEATURING THE FOLLOWING: JEWELRY, NECKLACES, RINGS, BRACELETS, BROOCHES, CHOKERS, EARRINGS, PEARLS, JEWELRY BOXES, JEWELRY CASES, CROSSES, AND KEYCHAINS, CLOTHING, SHIRTS, T-SHIRTS, APRONS, BEACH COVERUPS, BELTS, BELTS OF TEXTILE, CLOTH BIBS, HATS, HEADBANDS, COATS, MORNING COATS, NECKTIES, SCARVES, AND SHAWLS, FOOTWEAR, SHOES, SLIPPERS, THONGS, AND FLIP FLOPS, BAGS, OVERNIGHT BAGS, HANDBAGS, FASHION HANDBAGS, SHOULDER BAGS, SLING BAGS, TOILETRY BAGS SOLD EMPTY, TOTE BAGS, BACKPACKS, BABY BACKPACKS, BEACH BAGS, BOOKBAGS, CARRY-ALL BAGS, DIAPER BAGS, DRAWSTRING BAGS, POUCHES, MESSENGER BAGS, WALLETS, PURSES, CHANGE PURSES, CLUTCH PURSES, COIN PURSES, AND COSMETIC BAGS SOLD EMPTY, CANES AND WALKING STICKS, STATIONERY, STATIONERY WRITING PAPER AND ENVELOPES, BLANK JOURNALS, BLANK NOTE CARDS, BOOKMARKS, BOOKENDS, NOTEPADS, PEN AND PENCIL CASES, PENCILS, PHOTOGRAPHS, PAPERWEIGHTS, CARDS, OCCASION CARDS, GREETING CARDS, AND CHRISTMAS CARDS, WOOD CARVINGS, ORNAMENTS OF WOOD, FIGURES AND FIGURINES OF WOOD, ORNAMENTS OF BONE, FIGURES AND FIGURINES OF BONE, PERSONAL COMPACT MIRRORS, PICTURE FRAMES, PHOTOGRAPH FRAMES, WIND CHIMES, WOOD BOXES, AND WORKS OF ART OF MADE OF WOOD, CHRISTMAS DOLLS, CHRISTMAS STOCKINGS, CHRISTMAS DECORATIONS, CHRISTMAS TREE DECORATIONS, CHRISTMAS TREE ORNAMENTS, DOLLS, MUSICAL TOYS, AND CHESS SETS, COOKING UTENSILS AND HOUSEHOLD UTENSILS, NAMELY, WIRE BASKETS, SPATULAS, KITCHEN TONGS, SERVING FORKS, SERVING SPOONS, MIXING SPOONS, AND WOOD CHOPPING BLOCKS; ADVERTISING, MARKETING, AND PROMOTING THE GOODS OF OTHERS VIA PROMOTIONAL EXHIBITIONS (U.S. CLS. 100, 101 AND 102).

ELLEN BURNS, EXAMINING ATTORNEY

CLASS 35—(Continued).

SN 85-450,959. ELEGRITY, INC., SAN FRANCISCO, CA. FILED 10-19-2011.

ELEGRITY

THE MARK CONSISTS OF STANDARD CHARACTERS WITHOUT CLAIM TO ANY PARTICULAR FONT, STYLE, SIZE, OR COLOR.

OWNER OF U.S. REG. NOS. 2,579,556, 2,579,557 AND 2,713,848.

FOR WHOLESALE AND RETAIL STORE AND DISTRIBUTORSHIP SERVICES FEATURING COMPUTER SOFTWARE AND HARDWARE; BUSINESS PROCESS RE-ENGINEERING SERVICES; BUSINESS CONSULTATION SERVICES, NAMELY, BUSINESS PROCESS IMPROVEMENT AND ENTERPRISE ARCHITECTURE DESIGN; BUSINESS CONSULTING SERVICES RELATING TO THE INTEGRATION OF THE AREAS OF BUSINESS PROCESS TECHNOLOGY, ORGANIZATIONAL LEARNING, CHANGE MANAGEMENT, AND OPERATIONAL SUSTAINABILITY; BUSINESS CONSULTING AND INFORMATION SERVICES; AND BUSINESS MANAGEMENT CONSULTING (U.S. CLS. 100, 101 AND 102).

FIRST USE 12-31-1999; IN COMMERCE 12-31-1999.
ROBERT C. CLARK JR., EXAMINING ATTORNEY

CLASS 35—(Continued).

SN 85-451,541. FIFTH STREET GAMING, LLC, LAS VEGAS, NV. FILED 10-19-2011.

DOWNTOWN GRAND

THE MARK CONSISTS OF STANDARD CHARACTERS WITHOUT CLAIM TO ANY PARTICULAR FONT, STYLE, SIZE, OR COLOR.

FOR RETAIL CLOTHING STORES; RETAIL GIFT SHOPS; RETAIL STORE SERVICES FEATURING A WIDE VARIETY OF CONSUMER GOODS OF OTHERS; OPERATION OF A FREQUENT CASINO PLAYERS' INCENTIVE PROGRAM THAT ALLOWS MEMBERS TO REDEEM AWARDS FOR POINT EARNED THROUGH FREQUENT PATRONAGE; CONDUCTING BONUS CARD INCENTIVE AWARD PROGRAMS TO PROMOTE CASINO SERVICES (U.S. CLS. 100, 101 AND 102).

DAVID HOFFMAN, EXAMINING ATTORNEY

SN 85-451,977. ELEGRITY, INC., SAN FRANCISCO, CA. FILED 10-20-2011.

SN 85-451,174. GULF COAST COMMUNITY FOUNDATION, INC., VENICE, FL. FILED 10-19-2011.

GULF COAST GIVES

THE MARK CONSISTS OF STANDARD CHARACTERS WITHOUT CLAIM TO ANY PARTICULAR FONT, STYLE, SIZE, OR COLOR.

NO CLAIM IS MADE TO THE EXCLUSIVE RIGHT TO USE "GULF COAST", APART FROM THE MARK AS SHOWN.

FOR PROMOTING THE CHARITABLE SERVICES OF OTHERS, NAMELY, PROVIDING INDIVIDUALS WITH INFORMATION ABOUT VARIOUS CHARITIES FOR THE PURPOSE OF MAKING DONATIONS TO CHARITIES; PROVIDING A WEBSITE FEATURING INFORMATION IN THE FIELD OF CHARITABLE GIVING FOR THE PROMOTION OF CHARITABLE SERVICES OF OTHERS AND PROVIDING AN ONLINE MEANS FOR DONATING (U.S. CLS. 100, 101 AND 102).

FIRST USE 3-2-2011; IN COMMERCE 3-2-2011.
CAROLYN CATALDO, EXAMINING ATTORNEY

LBMS

THE MARK CONSISTS OF STANDARD CHARACTERS WITHOUT CLAIM TO ANY PARTICULAR FONT, STYLE, SIZE, OR COLOR.

OWNER OF U.S. REG. NO. 3,270,871.

FOR WHOLESALE AND RETAIL STORE AND DISTRIBUTORSHIP SERVICES FEATURING COMPUTER SOFTWARE AND HARDWARE; BUSINESS PROCESS RE-ENGINEERING SERVICES; BUSINESS CONSULTATION SERVICES, NAMELY, BUSINESS PROCESS IMPROVEMENT AND ENTERPRISE ARCHITECTURE DESIGN; BUSINESS CONSULTING SERVICES RELATING TO THE INTEGRATION OF THE AREAS OF BUSINESS PROCESS TECHNOLOGY, ORGANIZATIONAL LEARNING, CHANGE MANAGEMENT, AND OPERATIONAL SUSTAINABILITY; BUSINESS CONSULTING AND INFORMATION SERVICES; AND BUSINESS MANAGEMENT CONSULTING (U.S. CLS. 100, 101 AND 102).

FIRST USE 1-27-2006; IN COMMERCE 2-15-2006.
ROBERT C. CLARK JR., EXAMINING ATTORNEY

CLASS 35—(Continued).

SN 85-451,986. U.S. GAS & ELECTRIC, INC., NORTH MIAMI BEACH, FL. FILED 10-20-2011.

PARTNERS IN GAS & ELECTRIC

THE MARK CONSISTS OF STANDARD CHARACTERS WITHOUT CLAIM TO ANY PARTICULAR FONT, STYLE, SIZE, OR COLOR.

NO CLAIM IS MADE TO THE EXCLUSIVE RIGHT TO USE "GAS & ELECTRIC", APART FROM THE MARK AS SHOWN.

FOR ENERGY MANAGEMENT SERVICES, NAMELY, PROVIDING A SERVICE THAT ALLOWS CUSTOMERS TO PURCHASE ENERGY, NAMELY, ELECTRICITY AND NATURAL GAS; PROVIDING INCENTIVE PROGRAMS FOR COMMERCIAL CUSTOMERS FOR THE PURPOSES OF PROMOTING AND REWARDING NEW BUSINESS REFERRALS IN THE FIELD OF ENERGY MANAGEMENT SERVICES (U.S. CLS. 100, 101 AND 102).
BRIAN PINO, EXAMINING ATTORNEY

CLASS 35—(Continued).

SN 85-452,446. MARCH MARKETING, LLC, WHEATON, IL. FILED 10-20-2011.

March, LLC

THE MARK CONSISTS OF STANDARD CHARACTERS WITHOUT CLAIM TO ANY PARTICULAR FONT, STYLE, SIZE, OR COLOR.

NO CLAIM IS MADE TO THE EXCLUSIVE RIGHT TO USE "LLC", APART FROM THE MARK AS SHOWN.

FOR ADVERTISING AND MARKETING SERVICES, NAMELY, PROMOTING GOODS AND SERVICES OF OTHERS THAT ARE RELEVANT TO MILITARY VETERANS AND THEIR FAMILIES (U.S. CLS. 100, 101 AND 102).

SUSAN RICHARDS, EXAMINING ATTORNEY

SN 85-452,122. E-PULSETRAK.COM, LLC, LOUISVILLE, KY. FILED 10-20-2011.

Think Mobile First

THE MARK CONSISTS OF STANDARD CHARACTERS WITHOUT CLAIM TO ANY PARTICULAR FONT, STYLE, SIZE, OR COLOR.

NO CLAIM IS MADE TO THE EXCLUSIVE RIGHT TO USE "MOBILE", APART FROM THE MARK AS SHOWN.

FOR ADVERTISING AND MARKETING SERVICES PROVIDED BY MEANS OF INDIRECT METHODS OF MARKETING COMMUNICATIONS, NAMELY, SOCIAL MEDIA, SEARCH ENGINE MARKETING, INQUIRY MARKETING, INTERNET MARKETING, MOBILE MARKETING, BLOGGING AND OTHER FORMS OF PASSIVE, SHARABLE OR VIRAL COMMUNICATIONS CHANNELS (U.S. CLS. 100, 101 AND 102).

FIRST USE 10-15-2010; IN COMMERCE 10-15-2010.
ROBERT C. CLARK JR., EXAMINING ATTORNEY

SN 85-453,024. SLUMBERLAND, INC., LITTLE CANADA, MN. FILED 10-21-2011.

HOT BUYS!

THE MARK CONSISTS OF THE WORDS "HOT BUYS!" IN A STYLIZED LETTER FORM WITH THE WORD "HOT" APPEARING VERTICALLY.

FOR RETAIL STORE AND ON-LINE RETAIL STORE SERVICES FEATURING FURNITURE AND MATTRESSES (U.S. CLS. 100, 101 AND 102).

FIRST USE 9-9-2007; IN COMMERCE 9-9-2007.
JENNIFER VASQUEZ, EXAMINING ATTORNEY

CLASS 35—(Continued).

SN 85-453,866. MICRO INTELLECT MANAGEMENT, INC., LAS VEGAS, NV. FILED 10-22-2011.



NO CLAIM IS MADE TO THE EXCLUSIVE RIGHT TO USE "BEST BEAUTY PRODUCTS" AND "FEATURING AWARD WINNING BEAUTY PRODUCTS", APART FROM THE MARK AS SHOWN.

THE MARK CONSISTS OF A STYLIZED IMAGE RESEMBLING BEANS OR PEAS COMING OUT OF A POD. TO THE RIGHT OF THE GRAPHIC APPEAR THE WORDS "BEST BEAUTY PRODUCTS TODAY FEATURING AWARD WINNING BEAUTY PRODUCTS" APPEARING IN STYLIZED FONT.

FOR PROVIDING CONSUMER PRODUCT INFORMATION VIA THE INTERNET; PROVISION OF INFORMATION AND ADVICE TO CONSUMERS REGARDING THE SELECTION OF PRODUCTS AND ITEMS TO BE PURCHASED; ONLINE RETAIL STORE SERVICES FEATURING BEAUTY PRODUCTS (U.S. CLS. 100, 101 AND 102).

ADA HAN, EXAMINING ATTORNEY

SN 85-454,249. RANDALL, STACEY, CHARLOTTE, NC. FILED 10-24-2011.

Randall Research

THE MARK CONSISTS OF STANDARD CHARACTERS WITHOUT CLAIM TO ANY PARTICULAR FONT, STYLE, SIZE, OR COLOR.

NO CLAIM IS MADE TO THE EXCLUSIVE RIGHT TO USE "RESEARCH", APART FROM THE MARK AS SHOWN.

FOR HUMAN RESOURCES CONSULTATION (U.S. CLS. 100, 101 AND 102).

FIRST USE 9-1-2011; IN COMMERCE 9-6-2011.

ARETHA SOMERVILLE, EXAMINING ATTORNEY

SN 85-455,296. PETERSON AND SON ADVERTISING, INC., CHARLOTTE, NC. FILED 10-25-2011.

OVER 60 IN AMERICA

THE MARK CONSISTS OF STANDARD CHARACTERS WITHOUT CLAIM TO ANY PARTICULAR FONT, STYLE, SIZE, OR COLOR.

FOR DIRECT MAIL MARKETING SERVICES (U.S. CLS. 100, 101 AND 102).

CYNTHIA TRIPI, EXAMINING ATTORNEY

CLASS 35—(Continued).

SN 85-455,784. REDCOIN, INC., CHAPEL HILL, NC. FILED 10-25-2011.



THE COLOR(S) RED, BLACK AND WHITE IS/ARE CLAIMED AS A FEATURE OF THE MARK.

THE MARK CONSISTS OF THE WORD "REDCOIN" WRITTEN WITH THE LETTERS "RED" IN THE COLOR RED AND THE LETTERS "C" AND "IN" IN THE COLOR BLACK. THE LETTER "O" CONSISTS OF A DEPICTION OF A RED COIN WITH A WHITE INTERIOR. ABOVE THIS DRAWING OF A RED COIN ARE DEPICTIONS OF THREE ADDITIONAL FALLING RED COINS.

FOR PROMOTING THE GOODS AND SERVICES OF OTHERS, NAMELY, BY OFFERING AN INTERNET-BASED PLATFORM THAT PROVIDES BUSINESSES AND OTHERS THE ABILITY TO CREATE AND SELF-GENERATE COUPONS, DEALS, OR SPECIAL OFFERS THAT CAN BE DOWNLOADED AND/OR REDEEMED BY CONSUMERS (U.S. CLS. 100, 101 AND 102).

ANNE MADDEN, EXAMINING ATTORNEY

SN 85-456,783. VARIETY WHOLESALERS, INC., HENDERSON, NC. FILED 10-26-2011.

WHERE SMART SHOPPERS SAVE
MONEY

THE MARK CONSISTS OF STANDARD CHARACTERS WITHOUT CLAIM TO ANY PARTICULAR FONT, STYLE, SIZE, OR COLOR.

FOR RETAIL DEPARTMENT STORE SERVICES (U.S. CLS. 100, 101 AND 102).

GRETTA YAO, EXAMINING ATTORNEY

CLASS 35—(Continued).

SN 85-456,932. NATIONAL CINEMEDIA, LLC, CENTENNIAL, CO. FILED 10-26-2011.

MOVIE NIGHT OUT

THE MARK CONSISTS OF STANDARD CHARACTERS WITHOUT CLAIM TO ANY PARTICULAR FONT, STYLE, SIZE, OR COLOR.

OWNER OF U.S. REG. NO. 4,051,772.

NO CLAIM IS MADE TO THE EXCLUSIVE RIGHT TO USE "MOVIE", APART FROM THE MARK AS SHOWN.

FOR ADVERTISING SERVICES; PROMOTING THE GOODS AND SERVICES OF OTHERS BY DISTRIBUTING ADVERTISING MATERIALS; CINEMA ADVERTISING; DISSEMINATION OF ADVERTISING FOR OTHERS VIA PUBLIC AND PRIVATE WIRELESS NETWORKS FOR DISPLAY ON MOBILE DEVICES; ADVERTISING VIA ELECTRONIC MEDIA AND SPECIFICALLY THE INTERNET; PROMOTING THE GOODS AND SERVICES OF OTHERS BY PROVIDING A WEBSITE FEATURING FACTS AND INFORMATION ABOUT AND RELATED TO MOTION PICTURES, TELEVISION AND ENTERTAINMENT EVENTS; PROMOTING THE GOODS AND SERVICES OF OTHERS BY PROVIDING LINKS TO THE WEBSITES OF OTHERS (U.S. CLS. 100, 101 AND 102).

FIRST USE 4-13-2010; IN COMMERCE 9-7-2010.
WILLIAM VERHOSEK, EXAMINING ATTORNEY

CLASS 35—(Continued).

SN 85-458,031. SRL, LLC, LEXINGTON, MA. FILED 10-27-2011.

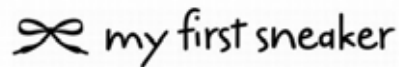
 The logo for "my first sneaker" features a stylized infinity symbol or bow-like graphic to the left of the text "my first sneaker" in a lowercase, handwritten-style font.

NO CLAIM IS MADE TO THE EXCLUSIVE RIGHT TO USE "SNEAKER", APART FROM THE MARK AS SHOWN. THE MARK CONSISTS OF A SHOE LACE TIED IN A BOW FOLLOWED BY LOWER CASE "MY FIRST SNEAKER".

FOR RETAIL SHOE AND FASHION ACCESSORIES STORE SERVICES; COMPUTERIZED ON-LINE RETAIL STORE SERVICES IN THE FIELD OF FOOTWEAR, APPAREL, ACCESSORIES AND BAGS, ACCESSIBLE VIA GLOBAL COMPUTER NETWORKS (U.S. CLS. 100, 101 AND 102).

CHRISTINA SOBRAL, EXAMINING ATTORNEY

SN 85-459,714. ROCKERS & GENTS, LLC, NEW YORK, NY. FILED 10-29-2011.

Rockers & Gents Emporium

SN 85-457,808. CHANTAL GUILLON DI DONATO, SAN FRANCISCO, CA. FILED 10-27-2011.

CHANTAL GUILLON

THE MARK CONSISTS OF STANDARD CHARACTERS WITHOUT CLAIM TO ANY PARTICULAR FONT, STYLE, SIZE, OR COLOR.

THE NAME "CHANTAL GUILLON" IDENTIFIES A LIVING INDIVIDUAL WHOSE CONSENT IS OF RECORD.

FOR RETAIL AND ON-LINE STORE SERVICES FEATURING BAKED GOODS, COOKIES, PASTRIES, MACAROONS, TEAS, BEVERAGES AND ICE CREAM (U.S. CLS. 100, 101 AND 102).

FIRST USE 1-0-2008; IN COMMERCE 1-0-2008.
MICHAEL ENGEL, EXAMINING ATTORNEY

THE MARK CONSISTS OF STANDARD CHARACTERS WITHOUT CLAIM TO ANY PARTICULAR FONT, STYLE, SIZE, OR COLOR.

NO CLAIM IS MADE TO THE EXCLUSIVE RIGHT TO USE "EMPORIUM", APART FROM THE MARK AS SHOWN.

FOR RETAIL STORE SERVICES AND ONLINE RETAIL STORE SERVICES FEATURING MEN'S CLOTHING, SHOES, MEN'S APPAREL, MEN'S JEWELRY AND WATCHES, MEN'S ACCESSORIES, NAMELY, CUFFLINKS, BELTS, GLASSES, SUNGLASSES, UMBRELLAS, POCKET SQUARES AND POCKET KERCHIEFS, WALKING STICKS AND NON-MEDICAL CANES, MOTORCYCLE HELMETS, MEN'S PERFUME/COLOGNE, LEATHER AND IMITATION LEATHER GOODS, NAMELY, LUGGAGE, SUITCASES, TRAVEL BAGS, LAPTOP COMPUTER BAGS, BRIEFCASES, ATTACHE CASES, ALL-PURPOSE CARRYING BAGS AND WALLET (U.S. CLS. 100, 101 AND 102).

ROBERT C. CLARK JR., EXAMINING ATTORNEY

CLASS 35—(Continued).

SN 85-461,136. BATH & BODY WORKS BRAND MANAGEMENT, INC., REYNOLDSBURG, OH. FILED 11-1-2011.

A HOUSE ISN'T A HOME WITHOUT A CANDLE

THE MARK CONSISTS OF STANDARD CHARACTERS WITHOUT CLAIM TO ANY PARTICULAR FONT, STYLE, SIZE, OR COLOR.

FOR RETAIL STORE SERVICES, MAIL ORDER RETAIL STORE SERVICES AND ONLINE RETAIL STORE SERVICES ALL IN THE FIELD OF HOME FRAGRANCE PRODUCTS AND ACCESSORIES (U.S. CLS. 100, 101 AND 102).

LOURDES AYALA, EXAMINING ATTORNEY

SN 85-465,178. KATZMAN, STEVEN, BOYNTON BEACH, FL. AND LAMBROS III, GEORGE, BOYNTON BEACH, FL. FILED 11-4-2011.

Lucky Day Rewards

THE MARK CONSISTS OF STANDARD CHARACTERS WITHOUT CLAIM TO ANY PARTICULAR FONT, STYLE, SIZE, OR COLOR.

NO CLAIM IS MADE TO THE EXCLUSIVE RIGHT TO USE "REWARDS", APART FROM THE MARK AS SHOWN.

FOR PROMOTING THE SALE OF GOODS AND SERVICES OF OTHERS BY CONDUCTING PROMOTIONAL CONTESTS AND DISTRIBUTING DISCOUNTS (U.S. CLS. 100, 101 AND 102).

FIRST USE 1-1-2009; IN COMMERCE 3-1-2009.
ADA HAN, EXAMINING ATTORNEY

SN 85-466,382. COLORTYME, INC., PLANO, TX. FILED 11-7-2011.

COLORTYME

THE MARK CONSISTS OF STANDARD CHARACTERS WITHOUT CLAIM TO ANY PARTICULAR FONT, STYLE, SIZE, OR COLOR.

OWNER OF U.S. REG. NOS. 1,216,129, 2,048,813 AND OTHERS.

FOR RETAIL STORE SERVICES FEATURING FURNITURE, APPLIANCES, CONSUMER ELECTRONICS, HOME ENTERTAINMENT PRODUCTS, COMPUTERS, TIRES, AND WHEEL RIMS (U.S. CLS. 100, 101 AND 102).

FIRST USE 3-9-1979; IN COMMERCE 3-9-1979.
GINA FINK, EXAMINING ATTORNEY

CLASS 35—(Continued).

SN 85-470,337. GUCCI AMERICA, INC., NEW YORK, NY. FILED 11-11-2011.



THE MARK CONSISTS OF THE DESIGN OF A STYLIZED TEDDY BEAR.

FOR RETAIL STORE SERVICES FEATURING CHILDREN'S CLOTHING AND FASHION ACCESSORIES (U.S. CLS. 100, 101 AND 102).

FIRST USE 5-0-2011; IN COMMERCE 5-0-2011.
DAWN HAN, EXAMINING ATTORNEY

SN 85-474,556. SOURCE INTERLINK MAGAZINES, LLC, EL SEGUNDO, CA. FILED 11-16-2011.

MUD LIFE

THE MARK CONSISTS OF STANDARD CHARACTERS WITHOUT CLAIM TO ANY PARTICULAR FONT, STYLE, SIZE, OR COLOR.

OWNER OF U.S. REG. NO. 3,748,352.

FOR ON-LINE RETAIL STORE SERVICES FEATURING APPAREL, BAGS, SOUVENIRS, STICKERS, TOYS, AND BACK ISSUES OF MAGAZINES (U.S. CLS. 100, 101 AND 102).

FONG HSU, EXAMINING ATTORNEY

CLASS 35—(Continued).

SN 85-475,174. JOHN ARAMIAN, RIDGEWOOD, NJ. FILED 11-17-2011.



NO CLAIM IS MADE TO THE EXCLUSIVE RIGHT TO USE "LOCAL DINING TV", APART FROM THE MARK AS SHOWN.

THE COLOR(S) ORANGE, BLACK, GREY IS/ARE CLAIMED AS A FEATURE OF THE MARK.

THE MARK CONSISTS OF THE WORD "LOCAL" IN ORANGE, THE WORD "DINING" IN BLACK, THE LETTERS "TV" IN BLACK, SMOKE IN GREY; THE LETTERS "TV" APPEARS IN A STYLIZED BLACK TELEVISION WITH AN ORANGE SCREEN.

FOR ADVERTISING AND MARKETING SERVICES PROVIDED BY MEANS OF INDIRECT METHODS OF MARKETING COMMUNICATIONS, NAMELY, SOCIAL MEDIA, SEARCH ENGINE MARKETING, INQUIRY MARKETING, INTERNET MARKETING, MOBILE MARKETING, BLOGGING AND OTHER FORMS OF PASSIVE, SHARABLE OR VIRAL COMMUNICATIONS CHANNELS (U.S. CLS. 100, 101 AND 102).

RICHARD WHITE, EXAMINING ATTORNEY

SN 85-480,092. SPECIALIZED BICYCLE COMPONENTS, INC., MORGAN HILL, CA. FILED 11-23-2011.



OWNER OF U.S. REG. NOS. 1,256,797, 3,989,171 AND OTHERS.

THE MARK CONSISTS OF THE STYLIZED LETTER "S". FOR WHOLESALE AND RETAIL STORE SERVICES FEATURING BICYCLES, PARTS AND FITTINGS FOR BICYCLES, CLOTHING, FOOTWEAR AND HEADGEAR, PROTECTIVE SPORTING EQUIPMENT, CYCLING AND SPORTING EQUIPMENT (U.S. CLS. 100, 101 AND 102).

FIRST USE 0-0-1982; IN COMMERCE 0-0-1982.
ZACHARY BELLO, EXAMINING ATTORNEY

CLASS 35—(Continued).

SN 85-481,699. CVS PHARMACY, INC., WOONSOCKET, RI. FILED 11-28-2011.

CLUBBELLEZA EXTRACARE

THE MARK CONSISTS OF STANDARD CHARACTERS WITHOUT CLAIM TO ANY PARTICULAR FONT, STYLE, SIZE, OR COLOR.

OWNER OF U.S. REG. NOS. 2,463,926 AND 3,995,169. THE ENGLISH TRANSLATION OF "BELLEZA" IN THE MARK IS "BEAUTY".

FOR PROMOTING THE CONSUMER GOODS OF OTHERS THROUGH DISTRIBUTION OF DISCOUNT CARDS AND THE ADMINISTRATION OF INCENTIVE AWARD PROGRAMS (U.S. CLS. 100, 101 AND 102).

SIMON TENG, EXAMINING ATTORNEY

SN 85-484,871. REED ELSEVIER INC., NEWTON, MA. FILED 12-1-2011.

JCK MOBILE

THE MARK CONSISTS OF STANDARD CHARACTERS WITHOUT CLAIM TO ANY PARTICULAR FONT, STYLE, SIZE, OR COLOR.

OWNER OF U.S. REG. NOS. 2,112,292, 2,750,147 AND 3,753,719.

NO CLAIM IS MADE TO THE EXCLUSIVE RIGHT TO USE "MOBILE", APART FROM THE MARK AS SHOWN.

FOR PROVIDING MOBILE SHOWROOMS FOR THE GOODS AND SERVICES OF OTHERS IN THE FIELD OF JEWELRY; PROVIDING BANNER ADVERTISING; PROVIDING TEXT MESSAGING MARKETING CAMPAIGNS VIA MOBILE DEVICES; PROVIDING ONLINE DIRECTORIES AND GUIDES FOR TRADESHOW EXHIBITIONS IN THE OF FIELD OF JEWELRY (U.S. CLS. 100, 101 AND 102).

FIRST USE 6-4-2010; IN COMMERCE 6-4-2010.
SANI KHOURI, EXAMINING ATTORNEY

SN 85-489,853. NORTHWEST MOTORSPORT, INC., PUYALLUP, WA. FILED 12-7-2011.

DONT GO REPO

THE MARK CONSISTS OF STANDARD CHARACTERS WITHOUT CLAIM TO ANY PARTICULAR FONT, STYLE, SIZE, OR COLOR.

FOR AUTOMOBILE DEALERSHIPS; DEALERSHIPS IN THE FIELD OF AUTOMOBILES, INCLUDING BUT NOT LIMITED TO, CARS, VANS, AND TRUCKS (U.S. CLS. 100, 101 AND 102).

FIRST USE 11-1-2011; IN COMMERCE 11-1-2011.
JACQUELINE A. LAVINE, EXAMINING ATTORNEY

CLASS 35—(Continued).

SN 85-493,096. PROGRESSIVE CASUALTY INSURANCE COMPANY, MAYFIELD VILLAGE, OH. FILED 12-12-2011.

SMARTSELL

THE MARK CONSISTS OF STANDARD CHARACTERS WITHOUT CLAIM TO ANY PARTICULAR FONT, STYLE, SIZE, OR COLOR.

FOR PROVIDING A SECURED ACCESS DATABASE OF SELLING SOLUTIONS VIA THE INTERNET THROUGH WHICH AUTHORIZED AGENTS CAN CONVERT POTENTIAL CUSTOMER LEADS INTO SALES OF PROPERTY AND CASUALTY INSURANCE POLICIES (U.S. CLS. 100, 101 AND 102).

ANDREA HACK, EXAMINING ATTORNEY

SN 85-495,062. DANA LIMITED, MAUMEE, OH. FILED 12-14-2011.

SPICER

THE MARK CONSISTS OF STANDARD CHARACTERS WITHOUT CLAIM TO ANY PARTICULAR FONT, STYLE, SIZE, OR COLOR.

FOR PROMOTIONAL SPONSORSHIP AND ADVERTISING IN THE FIELD OF AUTO PARTS THROUGH MOTOR SPORTS EVENTS, PUBLICATIONS, RADIO, TELEVISION AND VIA THE INTERNET (U.S. CLS. 100, 101 AND 102).

B. PARADEWELAI, EXAMINING ATTORNEY

SN 85-496,267. CLOCKWORK IP, LLC, SARASOTA, FL. FILED 12-15-2011.



THE MARK CONSISTS OF THE WORDING "CLIENT KINGDOM SECURING YOUR ROYALTY BY BUILDING LOYALTY" IN STYLIZED FORM.

FOR BUSINESS CONSULTATION AND BUSINESS MARKETING CONSULTATION FOR ELECTRICAL, PLUMBING, HEATING, VENTILATION AND AIR CONDITIONING BUSINESSES (U.S. CLS. 100, 101 AND 102).

FIRST USE 5-0-2003; IN COMMERCE 5-0-2003.
LESLIE RICHARDS, EXAMINING ATTORNEY

CLASS 35—(Continued).

SN 85-498,481. WILLIAMS, MARICUS, DOUGLASVILLE, GA. AND THOMAS, JENNIFER, DOUGLASVILLE, GA. FILED 12-19-2011.



NO CLAIM IS MADE TO THE EXCLUSIVE RIGHT TO USE "INC.", APART FROM THE MARK AS SHOWN.

THE STIPPLING IS FOR SHADING PURPOSES ONLY.

THE MARK CONSISTS OF A BIG CAT IN BETWEEN TWO TREES AND A MOON CENTERED DIRECTLY ABOVE. THE TEXT "JUNGLE 9 INC." BELOW THE IMAGE. A PARTIAL REFLECTION OF THE IMAGE IS ON THE GROUND BENEATH THE BIG CAT, MOON, AND TREES ONLY.

FOR PREPARATION OF CUSTOM OR NON-CUSTOM ADVERTISING FOR BUSINESSES FOR DISSEMINATION VIA THE WEB, CD OR DVD FOR OPTIONAL UPLOAD OR DOWNLOAD TO A COMPUTER; PROJECT MANAGEMENT SERVICES FOR OTHERS IN THE FIELDS OF LANGUAGE TRANSLATION, CUSTOM WRITING, TEXT ADAPTATION, INTERPRETING, AND PROOFREADING; PREPARATION OF CUSTOM ADVERTISEMENTS FOR OTHERS; CUSTOM WRITING SERVICES COMPRISING PUBLIC RELATIONS AND MARKETING MATERIALS FOR THE AUDIO AND VIDEO INDUSTRIES (U.S. CLS. 100, 101 AND 102).

ADA HAN, EXAMINING ATTORNEY

SN 85-499,047. NATIONAL CINEMEDIA, LLC, CENTENNIAL, CO. FILED 12-19-2011.

CINEMA SYNC

THE MARK CONSISTS OF STANDARD CHARACTERS WITHOUT CLAIM TO ANY PARTICULAR FONT, STYLE, SIZE, OR COLOR.

NO CLAIM IS MADE TO THE EXCLUSIVE RIGHT TO USE "CINEMA", APART FROM THE MARK AS SHOWN.

FOR ADVERTISING AND MARKETING SERVICES, NAMELY, PROMOTING THE GOODS AND SERVICES OF OTHERS (U.S. CLS. 100, 101 AND 102).

FIRST USE 12-14-2011; IN COMMERCE 12-14-2011.
WILLIAM VERHOSEK, EXAMINING ATTORNEY

CLASS 35—(Continued).

SN 85-499,486. AKAMAI TECHNOLOGIES, INC., CAMBRIDGE, MA. FILED 12-20-2011.

SHOPOGRAPHICS

THE MARK CONSISTS OF STANDARD CHARACTERS WITHOUT CLAIM TO ANY PARTICULAR FONT, STYLE, SIZE, OR COLOR.

FOR ON-LINE ADVERTISING AND MARKETING SERVICES (U.S. CLS. 100, 101 AND 102).
FIRST USE 11-15-2010; IN COMMERCE 11-15-2010.
CARRIE GENOVESE, EXAMINING ATTORNEY

SN 85-502,029. MJCM, LLC, DBA PINNACLE FINANCIAL STRATEGIES, HOUSTON, TX. FILED 12-22-2011.

WHAT COUNTS REWARDS

THE MARK CONSISTS OF STANDARD CHARACTERS WITHOUT CLAIM TO ANY PARTICULAR FONT, STYLE, SIZE, OR COLOR.

NO CLAIM IS MADE TO THE EXCLUSIVE RIGHT TO USE "REWARDS", APART FROM THE MARK AS SHOWN.
FOR BUSINESS CONSULTATION SERVICES; BUSINESS MARKETING CONSULTING SERVICES; BUSINESS MARKETING SERVICES; PROMOTION AND MARKETING SERVICES AND RELATED CONSULTING (U.S. CLS. 100, 101 AND 102).
DARRYL SPRUILL, EXAMINING ATTORNEY

SN 85-502,044. MJCM, LLC, DBA PINNACLE FINANCIAL STRATEGIES, HOUSTON, TX. FILED 12-22-2011.

SPENDING COUNTS

THE MARK CONSISTS OF STANDARD CHARACTERS WITHOUT CLAIM TO ANY PARTICULAR FONT, STYLE, SIZE, OR COLOR.

NO CLAIM IS MADE TO THE EXCLUSIVE RIGHT TO USE "SPENDING", APART FROM THE MARK AS SHOWN.
FOR BUSINESS CONSULTATION SERVICES; BUSINESS MARKETING CONSULTING SERVICES; BUSINESS MARKETING SERVICES; PROMOTION AND MARKETING SERVICES AND RELATED CONSULTING (U.S. CLS. 100, 101 AND 102).
DARRYL SPRUILL, EXAMINING ATTORNEY

CLASS 35—(Continued).

SN 85-502,977. AGILETRAILBLAZERS LLC, DOWNING-TOWN, PA. FILED 12-23-2011.

Continuous Business Value Delivery CBVD

THE MARK CONSISTS OF STANDARD CHARACTERS WITHOUT CLAIM TO ANY PARTICULAR FONT, STYLE, SIZE, OR COLOR.

NO CLAIM IS MADE TO THE EXCLUSIVE RIGHT TO USE "CONTINUOUS BUSINESS VALUE DELIVERY", APART FROM THE MARK AS SHOWN.
FOR BUSINESS MANAGEMENT CONSULTANCY SERVICES (U.S. CLS. 100, 101 AND 102).
DAVID COLLIER, EXAMINING ATTORNEY

SN 85-525,431. THE SLEEP TRAIN, INC., ROCKLIN, CA. FILED 1-25-2012.

NO DRAWING-SENSORY MARK

THE MARK IS A SOUND. THE MARK CONSISTS OF A TRAIN WHISTLE/TRAIN HORN.

FOR RETAIL STORE SERVICES IN THE FIELD OF MATTRESSES, BED BASES, BEDDING ACCESSORIES, BED HEADBOARDS AND DAYBEDS (U.S. CLS. 100, 101 AND 102).
FIRST USE 5-0-1993; IN COMMERCE 5-0-1993.
JASON BLAIR, EXAMINING ATTORNEY

SN 85-975,001. ALLIANCE TRADING, INC., COVINGTON, LA. FILED 6-23-2010.



NO CLAIM IS MADE TO THE EXCLUSIVE RIGHT TO USE "CORP", APART FROM THE MARK AS SHOWN.

THE COLOR(S) BLUE AND BLACK IS/ARE CLAIMED AS A FEATURE OF THE MARK.

THE MARK CONSISTS OF A BLACK PARALLELOGRAM INTERSECTED BY A BLUE WAVE, WITH "POOLCORP" TO THE RIGHT, WITH THE "POOL" IN BLUE LETTERS AND THE "CORP" IN BLACK.

SEC. 2(F).
FOR ADVERTISING, MARKETING AND PROMOTION SERVICES (U.S. CLS. 100, 101 AND 102).
FIRST USE 12-31-2005; IN COMMERCE 12-31-2005.
DOMINIC J. FERRAIUOLO, EXAMINING ATTORNEY

CLASS 36—INSURANCE AND FINANCIAL

SN 76-709,374. HEALTHSHARE, AUSTIN, TX. FILED 10-12-2011.

THA Insurance Services

THE MARK CONSISTS OF STANDARD CHARACTERS WITHOUT CLAIM TO ANY PARTICULAR FONT, STYLE, SIZE, OR COLOR.

NO CLAIM IS MADE TO THE EXCLUSIVE RIGHT TO USE "INSURANCE SERVICES", APART FROM THE MARK AS SHOWN.

FOR CONSULTING AND INFORMATION CONCERNING INSURANCE, INSURANCE ADMINISTRATION, INSURANCE AGENCY AND BROKERAGE, INSURANCE BROKERAGE SERVICES, INSURANCE CLAIMS ADMINISTRATION, INSURANCE CLAIMS PROCESSING, INSURANCE CONSULTANCY, INSURANCE CONSULTATION (U.S. CLS. 100, 101 AND 102).

FIRST USE 9-14-2011; IN COMMERCE 9-14-2011.
ELISSA GARBER KON, EXAMINING ATTORNEY

SN 77-955,824. UPFRONT MEGATAINMENT, INC., ATLANTA, GA. FILED 3-10-2010.

DEVYNE INTERVENTION

THE MARK CONSISTS OF STANDARD CHARACTERS WITHOUT CLAIM TO ANY PARTICULAR FONT, STYLE, SIZE, OR COLOR.

FOR CHARITABLE FOUNDATION SERVICES, NAMELY, PROVIDING FUNDRAISING ACTIVITIES, FUNDING, SCHOLARSHIPS, FINANCIAL SUPPORT SERVICES, AND FINANCIAL ASSISTANCE FOR CHILDREN THROUGH THE ACTIVITIES OF BUSINESSES AND INDIVIDUALS ENGAGED IN THE U.S. AND WORLDWIDE ENTERTAINMENT INDUSTRY (U.S. CLS. 100, 101 AND 102).

FIRST USE 11-1-2009; IN COMMERCE 11-1-2009.
KAELIE KUNG, EXAMINING ATTORNEY

CLASS 36—(Continued).

SN 79-099,440. COLLINSON GROUP (TRADEMARKS) LIMITED, GIBRALTAR, FILED 1-10-2011.



OWNER OF INTERNATIONAL REGISTRATION 1082794 DATED 1-10-2011, EXPIRES 1-10-2021.

NO CLAIM IS MADE TO THE EXCLUSIVE RIGHT TO USE "DIRECT", APART FROM THE MARK AS SHOWN.

THE COLOR(S) BROWN, WHITE, BLACK, BLUE, GREEN AND GRAY IS/ARE CLAIMED AS A FEATURE OF THE MARK.

THE MARK CONSISTS OF A STYLIZED IMAGE OF THE BUST OF A DOG IN BROWN, WHITE AND BLACK WITH A BROWN AND GRAY BARREL AROUND ITS NECK AND HOLDING A BLUE AND GREEN GLOBE OF THE EARTH, ABOVE A BLUE ROUND-CORNERED BANNER WITH THE WORDS "COLUMBUS DIRECT", WITH THREE DOTS IN THREE SHADES OF BLUE UNDER THE WORD "DIRECT".

FOR INSURANCE AGENCY AND BROKERAGE SERVICES IN THE FIELDS OF TRAVEL INSURANCE, HOLIDAY INSURANCE, MOTOR INSURANCE, HOME INSURANCE, MORTGAGE PAYMENT PROTECTION INSURANCE, HEALTH INSURANCE AND PET INSURANCE; INSURANCE CONSULTANCY AND INSURANCE CLAIMS ADMINISTRATION AND PROCESSING IN THE FIELDS OF TRAVEL INSURANCE, HOLIDAY INSURANCE, MOTOR INSURANCE, HOME INSURANCE, MORTGAGE PAYMENT PROTECTION INSURANCE, HEALTH INSURANCE AND PET INSURANCE (U.S. CLS. 100, 101 AND 102).

JANICE L. MCMORROW, EXAMINING ATTORNEY

SN 79-104,060. OPTIVER HOLDING B.V., NETHERLANDS, FILED 7-11-2011.



OWNER OF INTERNATIONAL REGISTRATION 1094585 DATED 7-11-2011, EXPIRES 7-11-2021.

OWNER OF U.S. REG. NO. 2,611,403.

THE MARK CONSISTS OF A DESIGN OF A TRIANGLE. FOR FINANCIAL AFFAIRS, NAMELY, TRADING OF FINANCIAL INSTRUMENTS, SECURITIES, SHARES, OPTIONS AND OTHER DERIVATIVE PRODUCTS AS A MARKET MAKER, ALSO ON-LINE (U.S. CLS. 100, 101 AND 102).

KEVIN DINALLO, EXAMINING ATTORNEY

CLASS 36—(Continued).

SN 79-104,489. OPTIVER HOLDING B.V., NETHERLANDS, FILED 7-11-2011.

OPTIVER

THE MARK CONSISTS OF STANDARD CHARACTERS WITHOUT CLAIM TO ANY PARTICULAR FONT, STYLE, SIZE, OR COLOR.

OWNER OF INTERNATIONAL REGISTRATION 1095584 DATED 7-11-2011, EXPIRES 7-11-2021.

OWNER OF U.S. REG. NOS. 2,613,860 AND 2,629,884. FOR FINANCIAL AFFAIRS, NAMELY, TRADING OF FINANCIAL INSTRUMENTS, SECURITIES, SHARES, OPTIONS AND OTHER DERIVATIVE PRODUCTS AS A MARKET MAKER, ALSO ON-LINE (U.S. CLS. 100, 101 AND 102).

CARYN GLASSER, EXAMINING ATTORNEY

SN 85-000,196. THE VALUATION EXCHANGE CORPORATION, GILLETTE, NJ. FILED 3-28-2010.

VALX

THE MARK CONSISTS OF STANDARD CHARACTERS WITHOUT CLAIM TO ANY PARTICULAR FONT, STYLE, SIZE, OR COLOR.

FOR FINANCIAL INVESTMENT SERVICES, NAMELY, ADMINISTERING THE ISSUANCE, UNDERWRITING AND DISTRIBUTION OF SECURITIES; FINANCIAL RISK MANAGEMENT; FINANCIAL SERVICES IN THE NATURE OF AN INVESTMENT SECURITY; FINANCIAL SERVICES, NAMELY, CONDUCTING A SECURITIES AND DERIVATIVES EXCHANGE; FINANCIAL SERVICES, NAMELY, PROVIDING FOR THE EXCHANGE OF FOREIGN CURRENCY, COMMODITIES, FINANCIAL DERIVATIVES, INTEREST RATE PRODUCTS, AND EQUITIES VIA THE INTERNET AND INTRANET SYSTEMS; FINANCIAL SERVICES, NAMELY, PROVIDING INFORMATION IN THE FIELDS OF FOREIGN CURRENCY, COMMODITIES, FINANCIAL DERIVATIVES, INTEREST RATE PRODUCTS, AND EQUITIES VIA THE INTERNET AND INTRANET SYSTEMS; FINANCIAL SERVICES, NAMELY, THE TRADING OF FINANCIAL INSTRUMENTS, SECURITIES, SHARES, OPTIONS AND OTHER DERIVATIVE PRODUCTS; ON-LINE TRADING OF FINANCIAL INSTRUMENTS, SHARES, OPTIONS AND OTHER DERIVATIVE PRODUCTS; ORGANIZATION OF ONLINE STOCK EXCHANGES FOR THE BENEFIT OF THE TRADE OF STOCKS AND OTHER FINANCIAL SECURITIES; ORGANIZATION OF STOCK EXCHANGES FOR THE BENEFIT OF THE TRADE OF STOCKS AND OTHER FINANCIAL VALUES; PROVIDING INFORMATION AND RESEARCH IN THE FIELD OF FINANCE AND FINANCIAL INVESTMENTS; PROVISION OF A FINANCIAL EXCHANGE FOR THE TRADING OF SECURITIES, SHARES AND OPTIONS AND OTHER DERIVATIVE PRODUCTS (U.S. CLS. 100, 101 AND 102).

TRACY WHITTAKER-BROWN, EXAMINING ATTORNEY

CLASS 36—(Continued).

SN 85-009,078. EYAL HOLDINGS LLC, NEW YORK, NY. FILED 4-8-2010.

Artflow Funding

THE MARK CONSISTS OF STANDARD CHARACTERS WITHOUT CLAIM TO ANY PARTICULAR FONT, STYLE, SIZE, OR COLOR.

NO CLAIM IS MADE TO THE EXCLUSIVE RIGHT TO USE "FUNDING", APART FROM THE MARK AS SHOWN.

FOR PROVIDING FINANCIAL SERVICES RELATING TO FINE ART, NAMELY, PROVIDING LOANS FOR THE PURPOSE OF PURCHASING FINE ART, RE-FINANCING OF FINE ART, AND ENGAGING IN FINE ART AUCTIONS; FINANCIAL LOAN CONSULTATION IN THE FIELD OF FINE ART AND FINE ART AUCTIONS (U.S. CLS. 100, 101 AND 102).

JIM RINGLE, EXAMINING ATTORNEY

SN 85-049,775. PANORAMA TOWERS CONDOMINIUM UNIT OWNERS ASSOCIATION, INC., LAS VEGAS, NV. FILED 5-27-2010.

PANORAMA TOWERS

THE MARK CONSISTS OF STANDARD CHARACTERS WITHOUT CLAIM TO ANY PARTICULAR FONT, STYLE, SIZE, OR COLOR.

FOR REAL ESTATE SERVICES, NAMELY, CONDOMINIUM MANAGEMENT SERVICES (U.S. CLS. 100, 101 AND 102).

FIRST USE 12-15-2006; IN COMMERCE 12-15-2006. DEBRA LEE, EXAMINING ATTORNEY

CLASS 36—(Continued).

SN 85-130,018. CJ 4DPLEX CO., LTD., SEOUL, REPUBLIC OF KOREA, FILED 9-15-2010.

4DPLEX

THE MARK CONSISTS OF STANDARD CHARACTERS WITHOUT CLAIM TO ANY PARTICULAR FONT, STYLE, SIZE, OR COLOR.

PRIORITY CLAIMED UNDER SEC. 44(D) ON REPUBLIC OF KOREA APPLICATION NO. 41-2010-2347, FILED 9-10-2010, REG. NO. 0223561, DATED 12-23-2011, EXPIRES 12-23-2021.

FOR BUILDING LEASING; RENTAL OF OFFICE SPACE; LEASING OF SHOPPING MALL SPACE; RENTAL OF THEATRES; RENTAL OF THEATRES FEATURING MOVIES AUDIENCE EFFECTS SUCH AS WIND, SCENT, WATER SPRAY, MOTION, VIBRATION, SMOKE, BUBBLE, LASER OR FLASH; INSURANCE INFORMATION; INSURANCE SERVICES, NAMELY, UNDERWRITING LIFE INSURANCE, UNDERWRITING HEALTH INSURANCE, UNDERWRITING ACCIDENT INSURANCE, UNDERWRITING FIRE INSURANCE; BANKING; ART APPRAISAL; LEASING OF REAL ESTATE; CUSTOMS BROKERAGE; GUARANTEE ASSURANCE UNDERWRITING; CHARITABLE FUNDRAISING SERVICES; FACTORING AGENCY SERVICES; LENDING AGAINST SECURITY (U.S. CLS. 100, 101 AND 102).
RON FAIRBANKS, EXAMINING ATTORNEY

CLASS 36—(Continued).

SN 85-215,988. SEACOAST BANKING CORPORATION OF FLORIDA, STUART, FL. FILED 1-12-2011.

SEACOAST WEALTH MANAGEMENT

THE MARK CONSISTS OF STANDARD CHARACTERS WITHOUT CLAIM TO ANY PARTICULAR FONT, STYLE, SIZE, OR COLOR.

OWNER OF U.S. REG. NOS. 3,534,187 AND 3,534,188.
NO CLAIM IS MADE TO THE EXCLUSIVE RIGHT TO USE "WEALTH MANAGEMENT", APART FROM THE MARK AS SHOWN.

FOR SECURITIES BROKERAGE SERVICES; SECURITIES TRADING AND INVESTING SERVICES FOR OTHERS VIA THE INTERNET; MANAGEMENT AND BROKERAGE IN THE FIELDS OF STOCKS, BONDS, OPTIONS, COMMODITIES, FUTURES AND OTHER SECURITIES, AND THE INVESTMENT OF FUNDS OF OTHERS (U.S. CLS. 100, 101 AND 102).
MARK SHINER, EXAMINING ATTORNEY

SN 85-215,999. SEACOAST BANKING CORPORATION OF FLORIDA, STUART, FL. FILED 1-12-2011.

SN 85-134,238. NATIONAL LAND REALTY, LLC, GREENVILLE, SC. FILED 9-21-2010.

**NATIONAL
LAND REALTY**

NO CLAIM IS MADE TO THE EXCLUSIVE RIGHT TO USE "NATIONAL LAND REALTY", APART FROM THE MARK AS SHOWN.

THE MARK CONSISTS OF THE WORD "NATIONAL" WITH A TREE COMING OUT OF THE "I" IN "NATIONAL". THE WORD "NATIONAL" IS UNDERLINED AND UNDERNEATH THAT IS THE WORDING "LAND REALTY".

FOR REAL ESTATE SERVICES, NAMELY, REAL ESTATE BROKERAGE (U.S. CLS. 100, 101 AND 102).
DEZMONA MIZELLE, EXAMINING ATTORNEY

Seacoast
WEALTH MANAGEMENT

OWNER OF U.S. REG. NOS. 3,534,187 AND 3,534,188.
NO CLAIM IS MADE TO THE EXCLUSIVE RIGHT TO USE "WEALTH MANAGEMENT", APART FROM THE MARK AS SHOWN.

THE MARK CONSISTS OF THE WORD "SEACOAST" WITH A PAIR OF WHITE SAIL BOATS IN A BLACK BACKGROUND ON THE LEFT AND A SOLID LINE UNDERNEATH AND THE WORDS "WEALTH MANAGEMENT" UNDERNEATH THE LINE.

FOR SECURITIES BROKERAGE SERVICES; SECURITIES TRADING AND INVESTING SERVICES FOR OTHERS VIA THE INTERNET; MANAGEMENT AND BROKERAGE IN THE FIELDS OF STOCKS, BONDS, OPTIONS, COMMODITIES, FUTURES AND OTHER SECURITIES, AND THE INVESTMENT OF FUNDS OF OTHERS (U.S. CLS. 100, 101 AND 102).
MARK SHINER, EXAMINING ATTORNEY

CLASS 36—(Continued).

SN 85-247,716. DOAN, KIM N, DBA OC GOLD, SANTA ANA, CA. FILED 2-21-2011.

OC GOLD

THE MARK CONSISTS OF STANDARD CHARACTERS WITHOUT CLAIM TO ANY PARTICULAR FONT, STYLE, SIZE, OR COLOR.

OWNER OF U.S. REG. NO. 3,833,218.

NO CLAIM IS MADE TO THE EXCLUSIVE RIGHT TO USE "GOLD", APART FROM THE MARK AS SHOWN. SEC. 2(F).

FOR FINANCIAL SERVICES, NAMELY, GOLD TRADING; PROVIDING MONETARY EXCHANGE SERVICES, NAMELY, EXCHANGING GOLD OF OTHERS FOR CASH (U.S. CLS. 100, 101 AND 102).

FIRST USE 2-1-2007; IN COMMERCE 2-1-2007.

KAREN K. BUSH, EXAMINING ATTORNEY

SN 85-251,715. BANK OF THE WEST, SAN FRANCISCO, CA. FILED 2-25-2011.

GO WEST

THE MARK CONSISTS OF STANDARD CHARACTERS WITHOUT CLAIM TO ANY PARTICULAR FONT, STYLE, SIZE, OR COLOR.

OWNER OF U.S. REG. NOS. 1,233,009, 3,680,786 AND OTHERS.

FOR FINANCIAL SERVICES, NAMELY, MONEY LENDING, MORTGAGE REFINANCING, INVESTMENT MANAGEMENT, AND WEALTH MANAGEMENT; TRUST SERVICES, NAMELY, INVESTMENT AND TRUST COMPANY SERVICES; INSURANCE BROKERAGE SERVICES; BANKING SERVICES (U.S. CLS. 100, 101 AND 102).

FLORENTINA BLANDU, EXAMINING ATTORNEY

CLASS 36—(Continued).

SN 85-258,555. LB PROPERTY MANAGEMENT, INC., SHERMAN OAKS, CA. FILED 3-4-2011.



NO CLAIM IS MADE TO THE EXCLUSIVE RIGHT TO USE "PROPERTY MANAGEMENT", APART FROM THE MARK AS SHOWN.

THE COLOR(S) WHITE, LIGHT BLUE, AND DARK BLUE IS/ARE CLAIMED AS A FEATURE OF THE MARK.

THE MARK CONSISTS OF A SQUARE WITH A WHITE BACKGROUND WITH LIGHT BLUE HORIZONTAL LINES INSIDE THAT MEET AN INCOMPLETE WHITE TRIANGLE ON THE BOTTOM OF THE SQUARE RISING UP TO THE RIGHT. FILLING THE TOP LEFT QUARTER OF THE SQUARE THERE IS A DARK BLUE "L" WHICH TOUCHES A DARK BLUE "B" WHICH FILLS THE BOTTOM RIGHT QUARTER OF THE SQUARE AND IS SET WITHIN THE WHITE INCOMPLETE TRIANGLE. ON THE BOTTOM OF SQUARE IS "PROPERTY MANAGEMENT" IN LIGHT BLUE LETTERS.

FOR REAL ESTATE SERVICES, NAMELY, PROPERTY MANAGEMENT SERVICES FOR CONDOMINIUM ASSOCIATIONS, HOMEOWNER ASSOCIATIONS AND APARTMENT BUILDINGS (U.S. CLS. 100, 101 AND 102).

FIRST USE 4-2-1993; IN COMMERCE 4-2-1993.

JOHN KELLY, EXAMINING ATTORNEY

SN 85-263,726. HAREWOOD ASSET MANAGEMENT, PARIS, FRANCE, FILED 3-10-2011.

THEAM

THE MARK CONSISTS OF STANDARD CHARACTERS WITHOUT CLAIM TO ANY PARTICULAR FONT, STYLE, SIZE, OR COLOR.

PRIORITY CLAIMED UNDER SEC. 44(D) ON FRANCE APPLICATION NO. 11/3804527, FILED 2-8-2011, REG. NO. 11/3804527, DATED 6-3-2011, EXPIRES 2-8-2021.

FOR FINANCIAL AFFAIRS AND MONETARY AFFAIRS, NAMELY, FINANCIAL INFORMATION, MANAGEMENT AND ANALYSIS SERVICES; FINANCIAL SERVICES, NAMELY, FINANCIAL CONSULTATION, ADVICE, RESEARCH, INFORMATION, PLANNING AND RESTRUCTURING SERVICES AND FINANCIAL PORTFOLIO ANALYSIS SERVICES; FINANCIAL AND INVESTMENT SERVICES, NAMELY, MANAGEMENT AND BROKERAGE IN THE FIELDS OF STOCKS, BONDS, OPTIONS, COMMODITIES, FUTURES AND OTHER SECURITIES, AND THE INVESTMENT OF FUNDS OF OTHERS; FINANCIAL AND INVESTMENT SERVICES, NAMELY, ASSET AND INVESTMENT ACQUISITION, CONSULTATION, ADVISORY AND DEVELOPMENT; FINANCIAL SERVICES, NAMELY, INVESTMENT FUND TRANSFER AND TRANSACTION SERVICES; FINANCING SERVICES; MUTUAL FUNDS

CLASS 36—(Continued).

BROKERAGE, INVESTMENT, AND DISTRIBUTION, AND ESTABLISHING MUTUAL FUNDS FOR OTHERS; CAPITAL INVESTMENTS SERVICES; INVESTMENT SERVICES, NAMELY, BROKERAGE, ADVICE, ASSET ACQUISITION, CONSULTATION, DEVELOPMENT AND MANAGEMENT SERVICES, INVESTMENT BANKING SERVICES; AND INVESTMENT COMPANIES SERVICES, NAMELY, MANAGEMENT, BROKERAGE, ADVICE, CONSULTATION AND CAPITAL INVESTMENT SERVICES; INVESTMENT MANAGEMENT SERVICES; COMMON FUNDS BROKERAGE, INVESTMENT, AND DISTRIBUTION SERVICES; AND SAVING FUNDS BROKERAGE, INVESTMENT, DISTRIBUTION SERVICES; MONEY MARKET FUND BROKERAGE, INVESTMENT, AND MANAGEMENT SERVICES; FINANCIAL PLANNING AND RESEARCH; PROVIDING BANKING, FINANCIAL AND MONETARY INFORMATION, ADVICE AND ASSISTANCE SERVICES; EXCHANGING MONEY; BANKING; PROVIDING ADVICE, ASSISTANCE AND INFORMATION SERVICES FOR ALL THE AFORESAID SERVICES (U.S. CLS. 100, 101 AND 102).

DARRYL SPRUILL, EXAMINING ATTORNEY

SN 85-276,304. GOODSEARCH, LLC, LOS ANGELES, CA. FILED 3-24-2011.

GOODCHANGE

THE MARK CONSISTS OF STANDARD CHARACTERS WITHOUT CLAIM TO ANY PARTICULAR FONT, STYLE, SIZE, OR COLOR.

OWNER OF U.S. REG. NOS. 3,424,170, 3,743,390 AND OTHERS.

FOR PROVIDING REBATE-FUNDED CHARITABLE DONATION SERVICES, NAMELY, PROVIDING A CHARITABLE DONATION SERVICE BY WHICH USERS CAN ROUND UP THE AMOUNT OF A PURCHASE WITH THE ADDITIONAL AMOUNT GOING TO A CHARITY, NOT-FOR-PROFIT, PHILANTHROPIC ORGANIZATION, ASSOCIATION, SCHOOL, CAUSE, OR CIVIC GROUP OF THEIR CHOICE; CHARITABLE FUNDRAISING SERVICES; CHARITABLE FUNDRAISING SERVICES, NAMELY, SHARING PROFITS OR PROCEEDS FROM ONLINE PURCHASES, ONLINE TRANSACTIONS AND COMMERCIAL WEBSITES; CHARITABLE FUNDRAISING SERVICES, NAMELY, RAISING FUNDS THROUGH ONLINE SHOPPING; CHARITABLE FUNDRAISING SERVICES BY MEANS OF SELLING GOODS TO RAISE FUNDS; ON-LINE CHARITABLE FUNDRAISING SERVICES; FUNDRAISING SERVICES, NAMELY, SHARING PROFITS FROM THE SALE OF SOCIALLY RESPONSIBLE PRODUCTS WITH NOT-FOR-PROFIT ORGANIZATIONS, SCHOOLS, AND CIVIC GROUPS; CHARITABLE FUNDRAISING, NAMELY, RAISING MONIES FOR CHARITIES AND NON-PROFIT ORGANIZATIONS AND ASSOCIATIONS; CHARITABLE FUNDRAISING SERVICES EFFECTED THROUGH THE ONLINE RETAIL SALE OF MERCHANDISE, PRODUCTS, AND SERVICES; CHARITABLE FUNDRAISING SERVICES FOR CHARITIES AND NON-PROFIT ORGANIZATIONS AND ASSOCIATIONS (U.S. CLS. 100, 101 AND 102).

ALAIN LAPTER, EXAMINING ATTORNEY

CLASS 36—(Continued).

SN 85-283,549. INSTITUTIONAL INVESTOR, INC., NEW YORK, NY. FILED 4-1-2011.

IIsearches

THE MARK CONSISTS OF STANDARD CHARACTERS WITHOUT CLAIM TO ANY PARTICULAR FONT, STYLE, SIZE, OR COLOR.

SEC. 2(F).

FOR ELECTRONICALLY PROVIDING ONLINE FINANCIAL NEWS AND INFORMATION RELATING TO INVESTMENT STRATEGIES, MONEY MANAGEMENT AND ASSET ALLOCATION; ELECTRONICALLY PROVIDING ONLINE FINANCIAL INFORMATION AND DATA RELATING TO INVESTMENT STRATEGIES, MONEY MANAGEMENT AND ASSET ALLOCATION VIA E-MAIL NOTIFICATION ALERTS (U.S. CLS. 100, 101 AND 102).

FIRST USE 0-0-1999; IN COMMERCE 0-0-1999.

LINDSEY RUBIN, EXAMINING ATTORNEY

SN 85-286,584. FAUNUS GROUP INTERNATIONAL, INC., NEW YORK, NY. FILED 4-5-2011.

THE FIRST NAME IN INTERNATIONAL FINANCE

THE MARK CONSISTS OF STANDARD CHARACTERS WITHOUT CLAIM TO ANY PARTICULAR FONT, STYLE, SIZE, OR COLOR.

NO CLAIM IS MADE TO THE EXCLUSIVE RIGHT TO USE "INTERNATIONAL FINANCE", APART FROM THE MARK AS SHOWN.

FOR PROVIDING FINANCIAL ANALYSIS AND CONSULTATION SERVICES; FINANCIAL EXCHANGE SERVICES (U.S. CLS. 100, 101 AND 102).

LAURIE KAUFMAN, EXAMINING ATTORNEY

SN 85-287,826. MEREDITH CORPORATION, DES MOINES, IA. FILED 4-6-2011.

DISTINCTIVE COLLECTION BY BETTER HOMES AND GARDENS REAL ESTATE

THE MARK CONSISTS OF STANDARD CHARACTERS WITHOUT CLAIM TO ANY PARTICULAR FONT, STYLE, SIZE, OR COLOR.

NO CLAIM IS MADE TO THE EXCLUSIVE RIGHT TO USE "REAL ESTATE", APART FROM THE MARK AS SHOWN.

FOR REAL ESTATE BROKERAGE SERVICES (U.S. CLS. 100, 101 AND 102).

FIRST USE 5-6-2011; IN COMMERCE 5-6-2011.

NAKWAMA ANKRAH, EXAMINING ATTORNEY

CLASS 36—(Continued).

SN 85-287,833. MEREDITH CORPORATION, DES MOINES, IA. FILED 4-6-2011.

LIFESTYLE PORTFOLIO BY
BETTER HOMES AND GARDENS
REAL ESTATE

THE MARK CONSISTS OF STANDARD CHARACTERS WITHOUT CLAIM TO ANY PARTICULAR FONT, STYLE, SIZE, OR COLOR.

NO CLAIM IS MADE TO THE EXCLUSIVE RIGHT TO USE "REAL ESTATE", APART FROM THE MARK AS SHOWN.

FOR REAL ESTATE BROKERAGE SERVICES (U.S. CLS. 100, 101 AND 102).

NAAKWAMA ANKRAH, EXAMINING ATTORNEY

SN 85-290,696. WESTLAKE FINANCIAL GROUP, INC., CHICAGO, IL. FILED 4-8-2011.

BenefitsTalk

THE MARK CONSISTS OF STANDARD CHARACTERS WITHOUT CLAIM TO ANY PARTICULAR FONT, STYLE, SIZE, OR COLOR.

FOR PROVIDING AN INTERNET BASED PORTAL FOR ENROLLMENT OF EMPLOYEES TO WORK-RELATED PROGRAMS, NAMELY, EMPLOYEE BENEFIT PLANS CONCERNING INSURANCE AND FINANCE (U.S. CLS. 100, 101 AND 102).

MICHELLE DUBOIS, EXAMINING ATTORNEY

SN 85-297,910. MIDFIRST BANK, A FEDERALLY CHARTERED SAVINGS ASSOCIATION, OKLAHOMA CITY, OK. FILED 4-18-2011.

iManage Business Express

THE MARK CONSISTS OF STANDARD CHARACTERS WITHOUT CLAIM TO ANY PARTICULAR FONT, STYLE, SIZE, OR COLOR.

OWNER OF U.S. REG. NOS. 2,940,523, 3,383,309 AND OTHERS.

NO CLAIM IS MADE TO THE EXCLUSIVE RIGHT TO USE "BUSINESS" AND "EXPRESS", APART FROM THE MARK AS SHOWN.

FOR ELECTRONIC BANKING VIA A GLOBAL COMPUTER NETWORK; MERCHANT BANKING SERVICES (U.S. CLS. 100, 101 AND 102).

FIRST USE 2-2-2010; IN COMMERCE 3-15-2010.

GINA FINK, EXAMINING ATTORNEY

CLASS 36—(Continued).

SN 85-298,236. DANIELSON, HUGH, D, KENNESAW, GA. FILED 4-18-2011.



THE COLOR(S) GREEN, WHITE AND BLUE IS/ARE CLAIMED AS A FEATURE OF THE MARK.

THE MARK CONSISTS OF THE TERM "PLAY" IN THE COLOR GREEN WITH THE LETTER "P" CAPITALIZED AND THE LETTERS "LAY" SHOWN IN LOWER CASE. THE NUMERAL "18" FOLLOWS THE TERM "PLAY" AND IS SHOWN IN THE COLOR GREEN. THE NUMERAL "4" FOLLOWS THE NUMERAL "18" AND IS SHOWN IN WHITE, BOTH OF THE NUMBERS "18" AND "4" ARE ENCLOSED WITHIN A BLUE CIRCULAR DESIGN. TO THE RIGHT OF THE CIRCLE DESIGN IS THE TERM "BLUE" SHOWN IN THE COLOR BLUE WITH A CAPITAL "B" AND LOWER CASE LETTERS "LUE".

FOR CHARITABLE FUNDRAISING; CHARITABLE FUNDRAISING SERVICES BY MEANS OF A GOLF EVENT (U.S. CLS. 100, 101 AND 102).

RUSS HERMAN, EXAMINING ATTORNEY

SN 85-301,665. UNITEDHEALTH GROUP INCORPORATED, MINNETONKA, MN. FILED 4-21-2011.

UNITEDHEALTHCARE

THE MARK CONSISTS OF STANDARD CHARACTERS WITHOUT CLAIM TO ANY PARTICULAR FONT, STYLE, SIZE, OR COLOR.

OWNER OF U.S. REG. NOS. 1,967,622, 3,269,588 AND OTHERS.

FOR ADMINISTRATION OF EMPLOYEE BENEFIT PLANS CONCERNING INSURANCE AND FINANCE; ADMINISTRATION OF EMPLOYEE WELFARE BENEFIT PLANS CONCERNING INSURANCE AND FINANCE; ADMINISTRATION OF HEALTH CARE PLANS; ADMINISTRATION OF HEALTH CARE BENEFIT PLANS; ADMINISTRATION OF VISION CARE PLANS; ADMINISTRATION OF HEALTH CARE PLANS IN THE FIELDS OF CHIROPRACTIC, PHYSICAL MEDICINE, AND COMPLEMENTARY AND ALTERNATIVE MEDICINES; ADMINISTRATION AND MANAGEMENT OF PHARMACY BENEFIT AND PRESCRIPTION DRUG BENEFIT PROGRAMS; ADMINISTRATION OF PHARMACY BENEFIT PLANS; PHARMACY BENEFIT MANAGEMENT SERVICES; CLAIMS ADMINISTRATION SERVICES FOR DISABILITY BENEFIT PLANS OF OTHERS; REINSURANCE UNDERWRITING FOR DISABILITY PLANS; UNDERWRITING OF STOP-LOSS INSURANCE FOR SELF-FUNDED HEALTH BENEFIT PLANS OF OTHERS; INSURANCE UNDERWRITING IN THE FIELDS OF HEALTH AND HEALTHCARE INSURANCE; INSURANCE UNDERWRITING AND ADMINISTRATION IN THE FIELD OF DISABILITY INSURANCE; ELECTRONIC PROCESSING OF INSURANCE CLAIMS AND PAYMENT DATA, INCLUDING DISABILITY CLAIMS; DENTAL HEALTH INSURANCE UNDERWRITING AND ADMINISTRATION; DENTAL HEALTH INSURANCE UNDERWRITING AND ADMINISTRATION VIA A GLOBAL COMPUTER NETWORK; ADMINISTRATION OF DENTAL HEALTH PLANS; ADMINISTRATION OF EMPLOYEE BENEFIT DENTAL HEALTH PLANS; ADMINISTRATION OF PREFERRED PROVIDER PLANS IN THE FIELD OF

CLASS 36—(Continued).

HEALTH CARE; INSURANCE ACTUARIAL SERVICES IN THE FIELD OF HEALTH AND DISABILITY INSURANCE; PROVIDING INSURANCE UNDERWRITING AND ADMINISTRATION OF LIFE, ACCIDENT AND CRITICAL ILLNESS BENEFIT PLANS; HEALTH CARE INSURANCE UNDERWRITING AND ADMINISTRATION PROVIDED VIA A GLOBAL COMPUTER NETWORK; INSURANCE ADMINISTRATION AND INSURANCE CLAIMS ADMINISTRATION IN THE FIELD OF HEALTH CARE; INSURANCE ADMINISTRATION SERVICES, NAMELY, REPRICING OF MANAGED CARE INSURANCE CLAIMS; ADMINISTERING HEALTH CARE PROVIDER NETWORKS FEATURING ACCESS TO HEALTH CARE PLANS AND PROGRAMS OUTSIDE OF THE MEMBER PLAN NETWORK; PROVIDING BENEFITS ADMINISTRATION SERVICES FOR OTHERS, NAMELY, ADMINISTRATION OF EMPLOYEE HEALTH AND WELFARE BENEFIT PLANS; EMPLOYEE ASSISTANCE SERVICES, NAMELY, PROVIDING ON-LINE, TELEPHONIC, AND IN-PERSON CONSULTATION, INFORMATION AND ASSESSMENT FOR FINANCIAL ISSUES; THIRD-PARTY ADMINISTRATION OF HEALTH INSURANCE CLAIMS; THIRD-PARTY ADMINISTRATION OF HEALTH CARE BENEFIT PLANS; THIRD-PARTY ADMINISTRATION OF EMPLOYEE BENEFIT PLANS CONCERNING INSURANCE AND FINANCE; THIRD-PARTY ADMINISTRATION OF EMPLOYEE WELFARE BENEFIT PLANS; CLAIMS ADMINISTRATION SERVICES FOR LIFE INSURANCE BENEFIT PLANS OF OTHERS; INSURANCE SERVICES, NAMELY, ORGANIZING, ADMINISTERING, AND UNDERWRITING INSURANCE PLANS AND PROGRAMS IN THE FIELDS OF HEALTH AND LIFE INSURANCE; UNDERWRITING, ISSUANCE, AND ADMINISTRATION OF HEALTH INSURANCE POLICY RIDERS WHICH PROTECT POLICY HOLDERS FROM THE INCREASED COST OF INSURANCE ADMINISTERED UNDER THE CONSOLIDATED OMNIBUS BUDGET RECONCILIATION ACT (COBRA); INSURANCE SERVICES, NAMELY, UNDERWRITING OF SUPPLEMENTAL HEALTH INSURANCE COVERAGE, NAMELY, COBRA COVERAGE; PROVIDING INFORMATION IN THE FIELD OF HEALTH INSURANCE, HEALTH CARE BENEFIT PLANS, PHARMACY BENEFITS, FLEXIBLE SPENDING ACCOUNTS, HEALTH SAVINGS ACCOUNTS AND HEALTH REIMBURSEMENT ACCOUNTS BY MEANS OF AN INTERACTIVE WEBSITE VIA A GLOBAL COMPUTER NETWORK UTILIZING INTERACTIVE COMPUTER MODULES, SOFTWARE TOOLS AND VIDEO MODULES; PROVIDING HEALTH CARE PLAN INFORMATION ON INSURANCE MATTERS IN THE FIELDS OF HEALTH INSURANCE, HEALTH CARE BENEFIT PLANS, PHARMACY BENEFITS, FLEXIBLE SPENDING ACCOUNTS, HEALTH SAVINGS ACCOUNTS AND HEALTH REIMBURSEMENT ACCOUNTS; PROVIDING HEALTH INFORMATION VIA THE INTERNET IN THE FIELDS OF HEALTH INSURANCE, HEALTH CARE BENEFIT PLANS, PHARMACY BENEFITS, FLEXIBLE SPENDING ACCOUNTS, HEALTH SAVINGS ACCOUNTS AND HEALTH REIMBURSEMENT ACCOUNTS; CHARITABLE SERVICES, NAMELY, PROVIDING FINANCIAL SUPPORT TO PATIENTS WITH TERMINAL ILLNESSES FOR THE PURPOSE OF COVERING MEDICAL EXPENSES; CHARITABLE SERVICES, NAMELY, PROVIDING FINANCIAL ASSISTANCE TO MEET THE PHYSICAL, PSYCHOLOGICAL, SOCIAL AND OTHER SPECIAL NEEDS OF OTHERS; ORGANIZING PREPAID HEALTH CARE PLANS AND ADMINISTRATION OF PREPAID HEALTH CARE PLANS; PROVIDING ON-LINE HEALTH INSURANCE INFORMATION; ON-LINE HEALTH INSURANCE AND BENEFITS SERVICES, NAMELY, PROVIDING A DATABASE OF INFORMATION FOR THE PURPOSES OF INSURANCE ELIGIBILITY AND VERIFICATION, AND PROVIDING SECURE BENEFITS AND CLAIM INFORMATION, AND INFORMATION RE-

CLASS 36—(Continued).

GARDING CHANGES IN PRIMARY CARE PHYSICIANS; ADMINISTRATION OF PRE-PAID HEALTH CARE BENEFIT PLANS FOR MEDICAL CARE SERVICES PROVIDED TO ELDERLY AND CHRONICALLY ILL POPULATIONS; ADMINISTRATIVE SERVICE ORGANIZATION (ASO) SERVICES IN THE NATURE OF HEALTH INSURANCE CLAIMS PROCESSING, UNDERWRITING AND ACTUARIAL SERVICES; CHARITABLE FUNDRAISING SERVICES BY MEANS OF THE CREATION OF CARE FUNDS FOR TREATMENT OF TERMINAL ILLNESSES VIA AN ON-LINE SOCIAL NETWORKING SERVICE (U.S. CLS. 100, 101 AND 102).
AMY HELLA, EXAMINING ATTORNEY

SN 85-303,726. LIQUIDITY DEVELOPMENT, LLC, SAN CLEMENTE, CA. FILED 4-25-2011.

TRANSPARENT TRADING TRUST

THE MARK CONSISTS OF STANDARD CHARACTERS WITHOUT CLAIM TO ANY PARTICULAR FONT, STYLE, SIZE, OR COLOR.

NO CLAIM IS MADE TO THE EXCLUSIVE RIGHT TO USE "TRADING TRUST", APART FROM THE MARK AS SHOWN.

FOR INVESTMENT TRUSTS, NAMELY, LEVERAGED INVESTMENT TRUSTS; INVESTMENT TRUST SERVICES, NAMELY, LEVERAGED INVESTMENT TRUST SERVICES AND MANAGEMENT OF LEVERAGED INVESTMENT TRUSTS; INVESTMENT FUNDS (U.S. CLS. 100, 101 AND 102).

ZACHARY BELLO, EXAMINING ATTORNEY

SN 85-304,239. LIQUIDITY DEVELOPMENT, LLC, SAN CLEMENTE, CA. FILED 4-25-2011.

TRIPLE-T

THE MARK CONSISTS OF STANDARD CHARACTERS WITHOUT CLAIM TO ANY PARTICULAR FONT, STYLE, SIZE, OR COLOR.

FOR INVESTMENT TRUSTS, NAMELY, LEVERAGED INVESTMENT TRUSTS; INVESTMENT TRUST SERVICES, NAMELY, LEVERAGED INVESTMENT TRUST SERVICES AND MANAGEMENT OF LEVERAGED INVESTMENT TRUSTS; INVESTMENT FUNDS (U.S. CLS. 100, 101 AND 102).

ZACHARY BELLO, EXAMINING ATTORNEY

CLASS 36—(Continued).

SN 85-305,746. PHILIPPONE ASSOCIATES, INC., TA GLOBALREALESTATE.PRO, ROCHESTER, NY. FILED 4-27-2011.



THE STIPPLING IS A FEATURE OF THE MARK AND DOES NOT INDICATE COLOR; THE STIPPLING IS FOR SHADING PURPOSES ONLY.

THE COLOR(S) BLUE, GREEN, GRAY & YELLOW IS/ ARE CLAIMED AS A FEATURE OF THE MARK.

THE MARK CONSISTS OF A GLOBE OF THE EARTH WITH CONTINENTS AND LINES OF LATITUDE AND LONGITUDE IN DARK BLUE AND THE OCEANS IN LIGHT BLUE. THE GLOBE IS SITUATED INSIDE AN ATOMIC STRUCTURE CONSISTING OF THREE (3) GRAY CIRCULAR ORBITAL PATH LINES AND TWO (2) SMALLER GLOBES OF THE SAME LIGHT BLUE AS THE MAIN GLOBE ON EACH OF THE GRAY ORBITAL PATHS. EACH OF THE SIX (6) SMALLER ORBITAL GLOBES IS MARKED BY EITHER A SOLID OR OUTLINED IMAGE CENTERED ON ITS FACE: A GRAY SKYSCRAPER ON THE UPPER LEFT AT APPROXIMATELY THE ELEVEN O'CLOCK/135-DEGREE POSITION, FOLLOWED BY A GREEN TREE ON THE NEXT GLOBE FOUND CLOCKWISE AT APPROXIMATELY ONE O'CLOCK/45-DEGREE POSITION, FOLLOWED BY A YELLOW HOUSE ON THE NEXT GLOBE FOUND CLOCKWISE AT APPROXIMATELY THE THREE O'CLOCK/ZERO-DEGREE POSITION, FOLLOWED BY A GREEN TREE ON THE NEXT GLOBE FOUND CLOCKWISE AT APPROXIMATELY THE FIVE O'CLOCK/315-DEGREE POSITION, FOLLOWED BY A YELLOW HOUSE ON THE NEXT GLOBE FOUND CLOCKWISE IN AT APPROXIMATELY THE SEVEN O'CLOCK/225-DEGREE POSITION, FOLLOWED BY A GRAY SKYSCRAPER ON THE NEXT/FINAL ORBITAL GLOBE FOUND CLOCKWISE AT APPROXIMATELY THE NINE O'CLOCK/180-DEGREE POSITION. ANY BLACK ON THE IMAGE IS FOR OUTLINE AND/OR SHADING PURPOSES ONLY, AND ANY WHITE ON THE IMAGE IS FOR TRANSPARENT AREAS ONLY; NEITHER ARE EXPRESS OR SPECIFIC COLORS OF THE MARK.

FOR REAL ESTATE BROKERAGE (U.S. CLS. 100, 101 AND 102).

MICHAEL SOUDERS, EXAMINING ATTORNEY

SN 85-307,698. VOIP TECH LLC, AUSTIN, TX. FILED 4-28-2011.

Loco Por Ti

THE MARK CONSISTS OF STANDARD CHARACTERS WITHOUT CLAIM TO ANY PARTICULAR FONT, STYLE, SIZE, OR COLOR.

THE ENGLISH TRANSLATION OF "LOCO POR TI" IN THE MARK IS "CRAZY FOR YOU".

FOR PREPAID TELECOMMUNICATIONS CALLING CARD SERVICES (U.S. CLS. 100, 101 AND 102).

FIRST USE 4-28-2011; IN COMMERCE 4-28-2011.

B. PARADEWELAI, EXAMINING ATTORNEY

CLASS 36—(Continued).

SN 85-307,864. KOSS RESOURCE LLC, LOS ANGELES, CA. FILED 4-28-2011.

KOSS RESOURCE

THE MARK CONSISTS OF STANDARD CHARACTERS WITHOUT CLAIM TO ANY PARTICULAR FONT, STYLE, SIZE, OR COLOR.

FOR PROVIDING AN INTERNET WEBSITE PORTAL OFFERING REAL ESTATE INFORMATION (U.S. CLS. 100, 101 AND 102).

BARBARA RUTLAND, EXAMINING ATTORNEY

SN 85-314,047. THE PRUDENTIAL INSURANCE COMPANY OF AMERICA, NEWARK, NJ. FILED 5-6-2011.

LIVE FORWARD.

THE MARK CONSISTS OF STANDARD CHARACTERS WITHOUT CLAIM TO ANY PARTICULAR FONT, STYLE, SIZE, OR COLOR.

FOR INSURANCE PRODUCTS AND SERVICES, NAMELY, UNDERWRITING AND ADMINISTERING OF GROUP LIFE, DISABILITY, LONG TERM CARE, AND DENTAL INSURANCE (U.S. CLS. 100, 101 AND 102).

TRACY FLETCHER, EXAMINING ATTORNEY

SN 85-314,073. THE PRUDENTIAL INSURANCE COMPANY OF AMERICA, NEWARK, NJ. FILED 5-6-2011.

REAL LIFE REAL ANSWERS

THE MARK CONSISTS OF STANDARD CHARACTERS WITHOUT CLAIM TO ANY PARTICULAR FONT, STYLE, SIZE, OR COLOR.

FOR INSURANCE PRODUCTS AND SERVICES, NAMELY, UNDERWRITING AND ADMINISTERING OF GROUP LIFE, DISABILITY, LONG TERM CARE, AND DENTAL INSURANCE (U.S. CLS. 100, 101 AND 102).

TRACY FLETCHER, EXAMINING ATTORNEY

CLASS 36—(Continued).

SN 85-315,555. MACLAB ENTERPRISES, EDMONTON, ALBERTA, CANADA, FILED 5-9-2011.

MACLAB ENTERPRISES

THE MARK CONSISTS OF STANDARD CHARACTERS WITHOUT CLAIM TO ANY PARTICULAR FONT, STYLE, SIZE, OR COLOR.

OWNER OF CANADA REG. NO. TMA621,124, DATED 9-30-2004, EXPIRES 9-30-2019.

OWNER OF U.S. REG. NO. 2,951,540.

NO CLAIM IS MADE TO THE EXCLUSIVE RIGHT TO USE "ENTERPRISES", APART FROM THE MARK AS SHOWN.

FOR RESIDENTIAL AND COMMERCIAL PROPERTY DEVELOPMENT; RESIDENTIAL AND COMMERCIAL BUILDING CONSTRUCTION; REAL ESTATE MANAGEMENT FOR OTHERS (U.S. CLS. 100, 101 AND 102).

FRANK LATTUCA, EXAMINING ATTORNEY

CLASS 36—(Continued).

SN 85-327,124. FOOD BANK OF SOUTH JERSEY, INC., PENNSAUKEN, NJ. FILED 5-23-2011.



THE COLOR(S) RED, YELLOW, GREEN, ORANGE, WHITE AND BLACK IS/ARE CLAIMED AS A FEATURE OF THE MARK.

THE MARK CONSISTS OF THE STYLIZED WORD "HUNGERSTOCK" APPEARING IN GREEN ABOVE THE FANCIFUL CONFIGURATION OF A GUITAR OUTLINED IN GREEN WHICH IS FILLED WITH VARIOUS VEGETABLES INCLUDING PEPPERS, ASPARAGUS, SQUASH, CARROTS, LETTUCE, RADISHES, AND PEAS APPEARING IN THE COLORS RED, YELLOW, GREEN, ORANGE, WHITE AND BLACK.

FOR CHARITABLE FUNDRAISING SERVICES BY MEANS OF MUSICAL CONCERTS (U.S. CLS. 100, 101 AND 102).

ANTHONY RINKER, EXAMINING ATTORNEY

SN 85-332,034. WILMINGTON SAVINGS FUND SOCIETY, FSB, WILMINGTON, DE. FILED 5-27-2011.

CHRISTIANA TRUST

THE MARK CONSISTS OF STANDARD CHARACTERS WITHOUT CLAIM TO ANY PARTICULAR FONT, STYLE, SIZE, OR COLOR.

NO CLAIM IS MADE TO THE EXCLUSIVE RIGHT TO USE "TRUST", APART FROM THE MARK AS SHOWN.

FOR FINANCIAL ASSET MANAGEMENT (U.S. CLS. 100, 101 AND 102).

FIRST USE 9-0-1992; IN COMMERCE 9-0-1992.

MATTHEW EINSTEIN, EXAMINING ATTORNEY

SN 85-332,039. WILMINGTON SAVINGS FUND SOCIETY, FSB, WILMINGTON, DE. FILED 5-27-2011.

LeaseTerm

THE MARK CONSISTS OF STANDARD CHARACTERS WITHOUT CLAIM TO ANY PARTICULAR FONT, STYLE, SIZE, OR COLOR.

FOR INSURANCE CONSULTANCY; DESIGN AND DEVELOPMENT OF INSURANCE POLICIES FOR OTHERS; INSURANCE, NAMELY, UNDERWRITING, ISSUING AND ADMINISTRATION OF LEASE DEFAULT INSURANCE IN THE NATURE OF INSURANCE IN WHICH BENEFITS ARE PAID TO PROPERTY OWNERS FOR LOSS OF INCOME RESULTING FROM LEASE DEFAULTS (U.S. CLS. 100, 101 AND 102).

CIMMERIAN COLEMAN, EXAMINING ATTORNEY



NO CLAIM IS MADE TO THE EXCLUSIVE RIGHT TO USE "TRUST", "A DIVISION OF" AND "BANK", APART FROM THE MARK AS SHOWN.

THE MARK CONSISTS OF A DESIGN OF A CHAIR WITH THE WORDING "CHRISTIANA TRUST A DIVISION OF WSFS BANK".

FOR FINANCIAL ASSET MANAGEMENT (U.S. CLS. 100, 101 AND 102).

FIRST USE 12-4-2010; IN COMMERCE 12-4-2010.

MATTHEW EINSTEIN, EXAMINING ATTORNEY

CLASS 36—(Continued).

SN 85-332,985. BACHMAN, HOLLY CHOON HYANG, SAN FRANCISCO, CA. FILED 5-27-2011.

Mixed Roots Foundation

THE MARK CONSISTS OF STANDARD CHARACTERS WITHOUT CLAIM TO ANY PARTICULAR FONT, STYLE, SIZE, OR COLOR.

NO CLAIM IS MADE TO THE EXCLUSIVE RIGHT TO USE "FOUNDATION", APART FROM THE MARK AS SHOWN.

FOR CHARITABLE FOUNDATION SERVICES, NAMELY, PROVIDING FUNDRAISING ACTIVITIES, FUNDING, SCHOLARSHIPS AND/OR FINANCIAL ASSISTANCE FOR THE GLOBAL ADOPTEE COMMUNITY, NAMELY, ADOPTEE ORGANIZATIONS AND/OR ORGANIZATIONS THAT SERVE AS A RESOURCE TO THE ADOPTEE COMMUNITY, INDIVIDUAL ADOPTEES AND THEIR FAMILIES; CHARITABLE FUNDRAISING SERVICES (U.S. CLS. 100, 101 AND 102).

JANICE L. MCMORROW, EXAMINING ATTORNEY

CLASS 36—(Continued).

SN 85-341,002. CHRISTIANS FOR ISRAEL INTERNATIONAL, NIJKERK, NETHERLANDS, FILED 6-8-2011.

CHRISTIANS FOR ISRAEL

THE MARK CONSISTS OF STANDARD CHARACTERS WITHOUT CLAIM TO ANY PARTICULAR FONT, STYLE, SIZE, OR COLOR.

SEC. 2(F).

FOR CHARITABLE FUNDRAISING SERVICES; PROVIDING FINANCIAL ASSISTANCE TO MEET THE NEEDS OF CHILDREN AND YOUTH, FAMILIES, VICTIMS OF TERROR, AND NEEDY INDIVIDUALS IN ISRAEL AND TO SUPPORT IMMIGRATION OF JEWS TO ISRAEL; PROVIDING INFORMATION, AND PROVIDING INFORMATION VIA A GLOBAL COMMUNICATIONS NETWORK, RELATING TO CHARITABLE FUNDRAISING, GRANTS, PHILANTHROPIC SERVICES CONCERNING MONETARY DONATIONS, AND FINANCIAL SUPPORT TO JEWS AND PEOPLE IN ISRAEL (U.S. CLS. 100, 101 AND 102).

FIRST USE 0-0-1995; IN COMMERCE 0-0-1995.

ADA HAN, EXAMINING ATTORNEY

SN 85-356,479. SERVICIOS TURISTICOS EXCLUSIVOS, S.A. DE C.V., NUEVO VALLARTA, MEXICO, FILED 6-26-2011.

The Grand Mayan

THE MARK CONSISTS OF STANDARD CHARACTERS WITHOUT CLAIM TO ANY PARTICULAR FONT, STYLE, SIZE, OR COLOR.

FOR REAL ESTATE MANAGEMENT SERVICES; REAL ESTATE TIME-SHARING; VACATION REAL ESTATE TIME SHARE EXCHANGE SERVICES; VACATION REAL ESTATE TIME-SHARING; VACATION REAL ESTATE TIMESHARE SERVICES (U.S. CLS. 100, 101 AND 102).

JOHN WILKE, EXAMINING ATTORNEY

SN 85-340,609. BUDD, JOSEPH, BRENTWOOD, TN. FILED 6-8-2011.

TRUST IS THE MOST VALUABLE ASSET

SN 85-356,481. SERVICIOS TURISTICOS EXCLUSIVOS, S.A. DE C.V., NUEVO VALLARTA, MEXICO, FILED 6-26-2011.

Sea Garden

THE MARK CONSISTS OF STANDARD CHARACTERS WITHOUT CLAIM TO ANY PARTICULAR FONT, STYLE, SIZE, OR COLOR.

FOR INSURANCE BROKERAGE AND FINANCIAL SERVICES, NAMELY, FINANCIAL PLANNING AND INVESTMENT MANAGEMENT SERVICES (U.S. CLS. 100, 101 AND 102).

ZHALEH DELANEY, EXAMINING ATTORNEY

THE MARK CONSISTS OF STANDARD CHARACTERS WITHOUT CLAIM TO ANY PARTICULAR FONT, STYLE, SIZE, OR COLOR.

FOR REAL ESTATE TIME-SHARING; VACATION REAL ESTATE TIME-SHARING (U.S. CLS. 100, 101 AND 102).

JOHN WILKE, EXAMINING ATTORNEY

CLASS 36—(Continued).

SN 85-357,105. SORRENTO PACIFIC FINANCIAL LLC, SAN DIEGO, CA. FILED 6-27-2011.



NO CLAIM IS MADE TO THE EXCLUSIVE RIGHT TO USE "FINANCIAL, LLC", APART FROM THE MARK AS SHOWN.

THE COLOR(S) BLUE AND MAROON IS/ARE CLAIMED AS A FEATURE OF THE MARK.

THE MARK CONSISTS OF A BLUE SQUARE WITH ONE OR MORE ROUNDED CORNERS AND A MISCELLANEOUS MAROON SWIRL DESIGN WITH CURVES AND WAVED LINES SHAPED LIKE A PLANT LEAF RESEMBLING THE LETTER S GOING THROUGH THE SQUARE AND USED WITH THE NAME "SORRENTO PACIFIC FINANCIAL, LLC" IN BLUE FONT.

FOR FINANCIAL SERVICES, NAMELY, STOCK BROKERAGE SERVICES, BROKERAGE SERVICES IN THE NATURE OF MUTUAL FUND INVESTMENTS, PORTFOLIO MANAGEMENT, FUND AND INVESTMENT CONSULTATION, FINANCIAL INVESTMENTS IN THE FIELD OF GENERAL SECURITIES, AND PROVIDING INFORMATION IN THE FIELDS OF INVESTMENT AND FINANCE OVER COMPUTER NETWORKS AND GLOBAL COMMUNICATION NETWORKS (U.S. CLS. 100, 101 AND 102).

FIRST USE 8-10-2010; IN COMMERCE 8-10-2010.
KAPIL BHANOT, EXAMINING ATTORNEY

CLASS 36—(Continued).

SN 85-367,926. THE PRUDENTIAL INSURANCE COMPANY OF AMERICA, NEWARK, NJ. FILED 7-11-2011.

PRUDENTIAL'S PORTFOLIO PROTECTED BUY-OUT

THE MARK CONSISTS OF STANDARD CHARACTERS WITHOUT CLAIM TO ANY PARTICULAR FONT, STYLE, SIZE, OR COLOR.

NO CLAIM IS MADE TO THE EXCLUSIVE RIGHT TO USE "PORTFOLIO PROTECTED BUY-OUT", APART FROM THE MARK AS SHOWN.

FOR ANNUITY CONTRACT SERVICES, NAMELY, ISSUANCE AND ADMINISTRATION OF ANNUITIES OFFERING PENSION RISK TRANSFER SERVICES ASSOCIATED WITH QUALIFIED AND NON-QUALIFIED EMPLOYEE BENEFIT PLANS (U.S. CLS. 100, 101 AND 102).

FIRST USE 6-1-2010; IN COMMERCE 6-1-2010.
TRACY FLETCHER, EXAMINING ATTORNEY

SN 85-360,769. PACIFIC LIFE INSURANCE COMPANY, NEWPORT BEACH, CA. FILED 6-30-2011.

PACIFIC INDEX CHOICE

THE MARK CONSISTS OF STANDARD CHARACTERS WITHOUT CLAIM TO ANY PARTICULAR FONT, STYLE, SIZE, OR COLOR.

OWNER OF U.S. REG. NOS. 2,168,494, 3,240,511 AND 3,716,484.

NO CLAIM IS MADE TO THE EXCLUSIVE RIGHT TO USE "INDEX", APART FROM THE MARK AS SHOWN.

FOR INSURANCE AND FINANCIAL SERVICES, NAMELY, LIFE INSURANCE AND ANNUITY UNDERWRITING, INSURANCE AND ANNUITY ADMINISTRATION, FINANCIAL MANAGEMENT AND BROKERAGE SERVICES FOR ALL TYPES OF INSURANCE, REINSURANCE UNDERWRITING; INSURANCE CLAIMS ADMINISTRATION AND PROCESSING; INSURANCE CONSULTATION; ANNUITY SERVICES, NAMELY, ACCOUNT AND INVESTMENT ADMINISTRATION AND THE INVESTMENT AND DISTRIBUTION OF ANNUITIES (U.S. CLS. 100, 101 AND 102).

JANICE KIM, EXAMINING ATTORNEY

SN 85-367,982. THE PRUDENTIAL INSURANCE COMPANY OF AMERICA, NEWARK, NJ. FILED 7-11-2011.

PRUDENTIAL'S PORTFOLIO PROTECTED BUY-IN

THE MARK CONSISTS OF STANDARD CHARACTERS WITHOUT CLAIM TO ANY PARTICULAR FONT, STYLE, SIZE, OR COLOR.

NO CLAIM IS MADE TO THE EXCLUSIVE RIGHT TO USE "PORTFOLIO PROTECTED BUY-IN", APART FROM THE MARK AS SHOWN.

FOR ANNUITY CONTRACT SERVICES, NAMELY, ISSUANCE AND ADMINISTRATION OF ANNUITIES OFFERING PENSION RISK TRANSFER SERVICES ASSOCIATED WITH QUALIFIED AND NON-QUALIFIED EMPLOYEE BENEFIT PLANS (U.S. CLS. 100, 101 AND 102).

FIRST USE 5-1-2011; IN COMMERCE 5-1-2011.
TRACY FLETCHER, EXAMINING ATTORNEY

CLASS 36—(Continued).

SN 85-369,899. FIRST BANK AND TRUST COMPANY OF INDIANTOWN, INDIANTOWN, FL. FILED 7-13-2011.



NO CLAIM IS MADE TO THE EXCLUSIVE RIGHT TO USE "BANK AND TRUST" AND "FSB", APART FROM THE MARK AS SHOWN.

THE COLOR(S) MAROON AND BLACK IS/ARE CLAIMED AS A FEATURE OF THE MARK.

THE MARK CONSISTS OF AN IMAGE OF THE BUST OF A NATIVE AMERICAN INDIAN WEARING A FEATHER HEAD PIECE, IN BLACK, APPEARING INSIDE A BLACK CIRCLE OUTLINE, TO THE LEFT OF THE WORDS "FIRST BANK AND TRUST OF INDIANTOWN, FSB" IN MAROON. THE WORDS "FIRST BANK" ARE ABOVE THE WORDS "AND TRUST OF INDIANTOWN, FSB".

SEC. 2(F) AS TO "FIRST BANK AND TRUST OF INDIANTOWN, FSB".

FOR BANKING SERVICES (U.S. CLS. 100, 101 AND 102).

FIRST USE 0-0-1960; IN COMMERCE 0-0-1960.

KATHERINE E. HALMEN, EXAMINING ATTORNEY

CLASS 36—(Continued).

SN 85-390,348. CONNECT-GENS LLC, FORMERLY CULVER SPEAKING AND CONSULTING LLC, CINCINNATI, OH. FILED 8-5-2011.

CONNECT-GENS

THE MARK CONSISTS OF STANDARD CHARACTERS WITHOUT CLAIM TO ANY PARTICULAR FONT, STYLE, SIZE, OR COLOR.

FOR CONSULTING AND EDUCATIONAL SERVICES IN THE FIELD OF VALUES-BASED FINANCIAL, ESTATE AND INTERGENERATIONAL LEGACY PLANNING FOR INDIVIDUALS AND ORGANIZATIONS TO ACHIEVE THEIR PURPOSE (U.S. CLS. 100, 101 AND 102).

FIRST USE 6-1-2011; IN COMMERCE 6-1-2011.

LOURDES AYALA, EXAMINING ATTORNEY

SN 85-388,603. APCI FEDERAL CREDIT UNION, ALLENTOWN, PA. FILED 8-3-2011.

OWNER OF U.S. REG. NOS. 2,693,034 AND 2,693,035.

NO CLAIM IS MADE TO THE EXCLUSIVE RIGHT TO USE "EDEPOSIT", APART FROM THE MARK AS SHOWN.

THE MARK CONSISTS OF THE WORDING "APCI EDEPOSIT" WHERE THE FIRST "E" IN "EDEPOSIT" APPEARS ON A CIRCULAR BACKGROUND AND HAS AN ARROW POINTING TO IT.

FOR FINANCIAL SERVICES, NAMELY, ELECTRONIC REMOTE CHECK DEPOSIT SERVICES (U.S. CLS. 100, 101 AND 102).

KATHERINE CHANG, EXAMINING ATTORNEY

SN 85-392,085. INSURANCE CONNECTION AGENCY CORPORATION, ALEXANDRIA, VA. FILED 8-8-2011.

INSURANCE CONNECTION AGENCY

THE MARK CONSISTS OF STANDARD CHARACTERS WITHOUT CLAIM TO ANY PARTICULAR FONT, STYLE, SIZE, OR COLOR.

NO CLAIM IS MADE TO THE EXCLUSIVE RIGHT TO USE "INSURANCE" AND "AGENCY", APART FROM THE MARK AS SHOWN.

FOR INSURANCE AGENCIES IN THE FIELD OF GENERAL LIABILITY, COMMERCIAL AUTO, WORKERS COMPENSATION, PROPERTY INSURANCE, BONDS, DIRECTORS AND OFFICERS, ERRORS AND OMISSIONS, AND INLAND MARINE INSURANCE (U.S. CLS. 100, 101 AND 102).

FIRST USE 8-31-2002; IN COMMERCE 8-31-2002.

APRIL HESIK, EXAMINING ATTORNEY

CLASS 36—(Continued).

SN 85-397,450. ZAFFERANO CAPITAL LIMITED, GRAND CAYMAN, CAYMAN ISLANDS, FILED 8-14-2011.

ZAFF

THE MARK CONSISTS OF STANDARD CHARACTERS WITHOUT CLAIM TO ANY PARTICULAR FONT, STYLE, SIZE, OR COLOR.

PRIORITY CLAIMED UNDER SEC. 44(D) ON ERPNCMNTY TM OFC APPLICATION NO. 010193407, FILED 8-12-2011, REG. NO. 010193407, DATED 12-22-2011, EXPIRES 8-12-2021.

FOR FINANCIAL ASSET AND FUND MANAGEMENT SERVICES, NAMELY, MANAGEMENT OF CAPITAL INVESTMENT FUNDS, VENTURE CAPITAL FUNDS, PROPERTY INVESTMENT FUNDS, STOCK AND PRIVATE EQUITY INVESTMENT FUNDS, EMERGING MARKETS AND GROWTH COMPANY INVESTMENT FUNDS, BONDS INVESTMENT FUNDS, SECURITIES INVESTMENT FUNDS, COMMODITIES INVESTMENT FUNDS, AND LIQUID AND ILLIQUID FINANCIAL INSTRUMENTS; FINANCIAL SERVICES AND INVESTMENT SERVICES, NAMELY, INVESTING FUNDS FOR OTHERS, THE TRADING OF AND ASSISTING OTHERS WITH THE TRADING OF FINANCIAL INSTRUMENTS, STOCKS, EQUITIES, BONDS, COMMODITIES AND SECURITIES, AND IN INVESTMENT FUNDS; FINANCIAL INVESTMENT ADVISORY SERVICES, NAMELY, PROVIDING FINANCIAL INFORMATION RELATING TO INVESTMENT FUNDS, FINANCIAL INSTRUMENTS, STOCKS, EQUITIES, BONDS AND SECURITIES (U.S. CLS. 100, 101 AND 102).

NANCY CLARKE, EXAMINING ATTORNEY

SN 85-400,687. MARCO ESCAPES, INCORPORATED, MARCO ISLAND, FL. FILED 8-17-2011.

MARCO ESCAPES

THE MARK CONSISTS OF STANDARD CHARACTERS WITHOUT CLAIM TO ANY PARTICULAR FONT, STYLE, SIZE, OR COLOR.

NO CLAIM IS MADE TO THE EXCLUSIVE RIGHT TO USE "MARCO", APART FROM THE MARK AS SHOWN.

FOR REAL ESTATE SERVICES, NAMELY, RENTAL OF VACATION HOMES, CONDOMINIUMS, CABINS, AND VILLAS (U.S. CLS. 100, 101 AND 102).

FIRST USE 9-1-2010; IN COMMERCE 10-2-2010.

DAVID H. STINE, EXAMINING ATTORNEY

CLASS 36—(Continued).

SN 85-400,724. MARCO ESCAPES, INCORPORATED, MARCO ISLAND, FL. FILED 8-17-2011.



MARCO ESCAPES

NO CLAIM IS MADE TO THE EXCLUSIVE RIGHT TO USE "MARCO", APART FROM THE MARK AS SHOWN.

THE MARK CONSISTS OF THREE TREES OVER THE WORDS "MARCO ESCAPES".

FOR REAL ESTATE SERVICES, NAMELY, RENTAL OF VACATION HOMES, CONDOMINIUMS, CABINS, AND VILLAS (U.S. CLS. 100, 101 AND 102).

FIRST USE 9-1-2010; IN COMMERCE 10-2-2010.

DAVID H. STINE, EXAMINING ATTORNEY

SN 85-405,352. AUDIOMINE, LLC, GROTON, CT. FILED 8-23-2011.

AudioMine

THE MARK CONSISTS OF STANDARD CHARACTERS WITHOUT CLAIM TO ANY PARTICULAR FONT, STYLE, SIZE, OR COLOR.

FOR COLLECTING LICENSE FEES ON BEHALF OF INDEPENDENT WRITERS AND PUBLISHERS AND MAKING PAYMENTS TO THE COPYRIGHT OWNERS OF THE MUSIC (U.S. CLS. 100, 101 AND 102).

FIRST USE 10-15-2011; IN COMMERCE 10-15-2011.

ROBERT C. CLARK JR., EXAMINING ATTORNEY

SN 85-409,553. FUND FOR INVESTIGATIVE JOURNALISM, INC., WASHINGTON, DC. FILED 8-29-2011.

FUND FOR INVESTIGATIVE JOURNALISM

THE MARK CONSISTS OF STANDARD CHARACTERS WITHOUT CLAIM TO ANY PARTICULAR FONT, STYLE, SIZE, OR COLOR.

NO CLAIM IS MADE TO THE EXCLUSIVE RIGHT TO USE "FUND", APART FROM THE MARK AS SHOWN.

SEC. 2(F).

FOR PROVIDING GRANTS TO FREELANCE REPORTERS, AUTHORS AND NON-PROFIT NEWS ORGANIZATIONS TO FACILITATE THE PUBLICATION OF STORIES, BROADCASTS AND BOOKS (U.S. CLS. 100, 101 AND 102).

FIRST USE 12-31-1969; IN COMMERCE 12-31-1969.

WILLIAM ROSSMAN, EXAMINING ATTORNEY

CLASS 36—(Continued).

SN 85-413,230. KEMPER CORPORATION, CHICAGO, IL. FILED 9-1-2011.



NO CLAIM IS MADE TO THE EXCLUSIVE RIGHT TO USE "LIFE INSURANCE", APART FROM THE MARK AS SHOWN.

THE MARK CONSISTS OF A SOLID TRIANGLE AND A LINED TRIANGLE, CREATING THE IMPRESSION OF THE LETTER "K", AND THE WORDING "RELIABLE LIFE" TO THE RIGHT OF THE TRIANGLES WITH THE WORDING "INSURANCE" DIRECTLY BELOW.

FOR LIFE, HEALTH, ACCIDENT AND PROPERTY INSURANCE UNDERWRITING SERVICES (U.S. CLS. 100, 101 AND 102).

PAUL MORENO, EXAMINING ATTORNEY

SN 85-413,239. KEMPER CORPORATION, CHICAGO, IL. FILED 9-1-2011.



NO CLAIM IS MADE TO THE EXCLUSIVE RIGHT TO USE "HOME SERVICE COMPANIES", APART FROM THE MARK AS SHOWN.

THE MARK CONSISTS OF A SOLID TRIANGLE AND A LINED TRIANGLE, CREATING THE IMPRESSION OF THE LETTER "K", AND THE WORDING "KEMPER" TO THE RIGHT OF THE TRIANGLES WITH THE WORDING "HOME SERVICE COMPANIES" DIRECTLY BELOW.

FOR LIFE, HEALTH, ACCIDENT AND PROPERTY INSURANCE UNDERWRITING SERVICES (U.S. CLS. 100, 101 AND 102).

PAUL MORENO, EXAMINING ATTORNEY

SN 85-413,257. KEMPER CORPORATION, CHICAGO, IL. FILED 9-1-2011.



NO CLAIM IS MADE TO THE EXCLUSIVE RIGHT TO USE "MUTUAL SAVINGS LIFE INSURANCE", APART FROM THE MARK AS SHOWN.

THE MARK CONSISTS OF A SOLID TRIANGLE AND A LINED TRIANGLE, CREATING THE IMPRESSION OF THE LETTER "K", AND THE WORDING "MUTUAL SAVINGS" TO THE RIGHT OF THE TRIANGLES WITH THE WORDING "LIFE INSURANCE" DIRECTLY BELOW.

FOR LIFE, HEALTH, ACCIDENT AND PROPERTY INSURANCE UNDERWRITING SERVICES (U.S. CLS. 100, 101 AND 102).

PAUL MORENO, EXAMINING ATTORNEY

CLASS 36—(Continued).

SN 85-416,394. MEHTA, JAYESH, PLAINSBORO, NJ. AND MEHTA, PUSHPA, PLAINSBORO, NJ. FILED 9-7-2011.



FOR FINANCIAL VALUATIONS OF SECURITIES INVESTMENTS (U.S. CLS. 100, 101 AND 102).

FIRST USE 8-0-2011; IN COMMERCE 8-0-2011.

BARNEY CHARLON, EXAMINING ATTORNEY

SN 85-417,013. LEGAL ONE REALTY, DBA BAY PROPERTY GROUP, SAN FRANCISCO, CA. FILED 9-7-2011.



NO CLAIM IS MADE TO THE EXCLUSIVE RIGHT TO USE "PROPERTY GROUP", APART FROM THE MARK AS SHOWN.

THE COLOR(S) GREY, WHITE, AND BLUE IS/ARE CLAIMED AS A FEATURE OF THE MARK.

THE MARK CONSISTS OF A GREY RECTANGLE ON THE LEFT AND A BLUE RECTANGLE ON THE RIGHT CROSSED BY WHITE LINE SEGMENTS REPRESENTING A STYLIZED BRIDGE, ALL APPEARING ABOVE THE TOP SIDE OF A WHITE RECTANGLE CONTAINING THE STYLIZED WORDING "BAY PROPERTY GROUP" IN GREY.

FOR REAL ESTATE SERVICE, NAMELY, RENTAL PROPERTY MANAGEMENT (U.S. CLS. 100, 101 AND 102).

FIRST USE 8-18-2011; IN COMMERCE 8-18-2011.

KIM SAITO, EXAMINING ATTORNEY

CLASS 36—(Continued).

SN 85-418,346. PYGG PTY LTD, SURRY HILLS, AUSTRALIA, FILED 9-9-2011.

PYGG

THE MARK CONSISTS OF STANDARD CHARACTERS WITHOUT CLAIM TO ANY PARTICULAR FONT, STYLE, SIZE, OR COLOR.

FOR INSURANCE AND FINANCIAL SERVICES, NAMELY, ELECTRONIC FUNDS TRANSFER VIA ELECTRONIC COMMUNICATIONS NETWORKS; CLEARING AND RECONCILING FINANCIAL TRANSACTIONS AND LOANS VIA ELECTRONIC COMMUNICATIONS NETWORKS; ASSESSING CREDIT RATINGS VIA ELECTRONIC COMMUNICATIONS NETWORKS; PROVIDING A WIDE VARIETY OF PAYMENT AND FINANCIAL SERVICES, NAMELY, CREDIT CARD SERVICES, ISSUING CREDIT CARDS AND LINES OF CREDIT, PROCESSING AND TRANSMISSION OF BILLS AND PAYMENTS THEREOF, BILL PAYMENT SERVICES WITH GUARANTEED PAYMENT DELIVERY, AND BROKERAGE OF MONEY MARKET FUNDS, ALL CONDUCTED VIA A GLOBAL COMMUNICATIONS NETWORK (U.S. CLS. 100, 101 AND 102).

FIRST USE 6-15-2011; IN COMMERCE 8-2-2011.
 ASMAT KHAN, EXAMINING ATTORNEY

CLASS 36—(Continued).

SN 85-420,083. KEMPER CORPORATION, CHICAGO, IL, FILED 9-12-2011.



NO CLAIM IS MADE TO THE EXCLUSIVE RIGHT TO USE "LIFE INSURANCE", APART FROM THE MARK AS SHOWN.

THE MARK CONSISTS OF TWO SOLID TRIANGLES, CREATING THE IMPRESSION OF THE LETTER "K", AND THE WORDING "RELIABLE LIFE" TO THE RIGHT OF THE TRIANGLES WITH THE WORDING "INSURANCE" DIRECTLY BELOW.

FOR LIFE, HEALTH, ACCIDENT AND PROPERTY INSURANCE UNDERWRITING SERVICES (U.S. CLS. 100, 101 AND 102).
 FIRST USE 8-25-2011; IN COMMERCE 8-25-2011.
 PAUL MORENO, EXAMINING ATTORNEY

SN 85-420,089. KEMPER CORPORATION, CHICAGO, IL, FILED 9-12-2011.

SN 85-419,181. KEMPER CORPORATION, CHICAGO, IL, FILED 9-9-2011.



NO CLAIM IS MADE TO THE EXCLUSIVE RIGHT TO USE "MUTUAL SAVINGS LIFE INSURANCE", APART FROM THE MARK AS SHOWN.

THE MARK CONSISTS OF TWO SOLID TRIANGLES, CREATING THE IMPRESSION OF THE LETTER "K", AND THE WORDING "MUTUAL SAVINGS" TO THE RIGHT OF THE TRIANGLES WITH THE WORDING "LIFE INSURANCE" DIRECTLY BELOW.

FOR LIFE, HEALTH, ACCIDENT AND PROPERTY INSURANCE UNDERWRITING SERVICES (U.S. CLS. 100, 101 AND 102).
 FIRST USE 8-25-2011; IN COMMERCE 8-25-2011.
 PAUL MORENO, EXAMINING ATTORNEY



NO CLAIM IS MADE TO THE EXCLUSIVE RIGHT TO USE "HOME SERVICE COMPANIES", APART FROM THE MARK AS SHOWN.

THE MARK CONSISTS OF TWO SOLID TRIANGLES, CREATING THE IMPRESSION OF THE LETTER "K", AND THE WORDING "KEMPER" TO THE RIGHT OF THE TRIANGLES WITH THE WORDING "HOME SERVICE COMPANIES" DIRECTLY BELOW.

FOR LIFE, HEALTH, ACCIDENT AND PROPERTY INSURANCE UNDERWRITING SERVICES (U.S. CLS. 100, 101 AND 102).
 FIRST USE 8-25-2011; IN COMMERCE 8-25-2011.
 PAUL MORENO, EXAMINING ATTORNEY

CLASS 36—(Continued).

SN 85-421,643. GOLDMAN, SACHS & CO., NEW YORK, NY. FILED 9-13-2011.

Goldman Sachs Retirement Portfolio Completion Fund

THE MARK CONSISTS OF STANDARD CHARACTERS WITHOUT CLAIM TO ANY PARTICULAR FONT, STYLE, SIZE, OR COLOR.

OWNER OF U.S. REG. NOS. 1,975,880, 2,444,245 AND OTHERS.

NO CLAIM IS MADE TO THE EXCLUSIVE RIGHT TO USE "RETIREMENT PORTFOLIO" AND "FUND", APART FROM THE MARK AS SHOWN.

FOR FINANCIAL SERVICES, NAMELY, INVESTMENT BROKERAGE AND MANAGEMENT; SECURITIES BROKERAGE SERVICES; ELECTRONIC TRADING OF FINANCIAL INSTRUMENTS, SECURITIES, SHARE OPTIONS, OTHER DERIVATIVE PRODUCTS, HEDGE FUNDS, AND MUTUAL FUNDS; FINANCIAL PORTFOLIO MANAGEMENT SERVICES; INVESTMENT MANAGEMENT AND ADVISORY SERVICES; TRADING OF FINANCIAL SECURITIES; HEDGE FUND/MUTUAL FUNDS INVESTMENT MANAGEMENT SERVICES; FINANCIAL PLANNING SERVICES; MANAGEMENT OF FINANCIAL INVESTMENT ACCOUNTS; PORTFOLIO INVESTMENT ADVISORY SERVICES; BROKERAGE SERVICES IN THE FIELD OF STOCK, BOND, HEDGE FUND, AND MUTUAL FUND INVESTING; ESTABLISHING AND MANAGING STOCK FUNDS, BOND FUNDS, HEDGE FUNDS, AND MUTUAL FUNDS FOR OTHERS; FINANCIAL RESEARCH SERVICES; CONSULTING RELATED TO ALL THE FOREGOING SERVICES (U.S. CLS. 100, 101 AND 102).

JOHN SCHUYLER YARD, EXAMINING ATTORNEY

CLASS 36—(Continued).

SN 85-426,097. ALLY FINANCIAL INC., DETROIT, MI. FILED 9-19-2011.



OWNER OF U.S. REG. NOS. 3,667,813, 3,722,309 AND OTHERS.

NO CLAIM IS MADE TO THE EXCLUSIVE RIGHT TO USE "COMMERCIAL FINANCE", APART FROM THE MARK AS SHOWN.

THE MARK CONSISTS OF THE WORD "ALLY" IN LOWERCASE LETTERS FOLLOWED BY THE WORDS "COMMERCIAL FINANCE" IN A SLIGHTLY SMALLER FONT IN ALL CAPITAL LETTERS, WITH THE WORD "COMMERCIAL" ABOVE THE WORD "FINANCE".

FOR FINANCIAL SERVICES, NAMELY, ASSET-BASED LENDING, CASH FLOW LENDING, AND STRUCTURED FINANCE (U.S. CLS. 100, 101 AND 102).

MICHAEL LITZAU, EXAMINING ATTORNEY

SN 85-426,868. NAVRATILOVA, INC., PHILADELPHIA, PA. FILED 9-20-2011.

SN 85-423,259. UGOBBLEUP, LLC, ST. JOHNS, FL. FILED 9-15-2011.

UGobbleUp Devour the Deal

THE MARK CONSISTS OF STANDARD CHARACTERS WITHOUT CLAIM TO ANY PARTICULAR FONT, STYLE, SIZE, OR COLOR.

NO CLAIM IS MADE TO THE EXCLUSIVE RIGHT TO USE "DEAL", APART FROM THE MARK AS SHOWN.

FOR CHARITABLE FUNDRAISING FOR SCHOOLS FEATURING EMAIL ADVERTISING (U.S. CLS. 100, 101 AND 102).

FIRST USE 9-15-2010; IN COMMERCE 11-30-2010.

DAWN HAN, EXAMINING ATTORNEY



OWNER OF U.S. REG. NOS. 2,044,020 AND 3,594,244.

THE MARK CONSISTS OF THE DEPICTION OF A RAINBOW WHICH IS COMPRISED OF SQUARE AND RECTANGLE SHAPES ABOVE THE WORD "RAINBOW".

FOR CHARITABLE FUNDRAISING; CHARITABLE SERVICES, NAMELY, ACCEPTING, ADMINISTERING AND GRANTING FUNDS TO CHARITABLE, PHILANTHROPIC, EDUCATIONAL AND OTHER NOT-FOR-PROFIT ORGANIZATIONS (U.S. CLS. 100, 101 AND 102).

NAPOLEON SHARMA, EXAMINING ATTORNEY

CLASS 36—(Continued).

SN 85-427,820. L&S ASSOCIATES, INC., LANSING, MI. FILED 9-21-2011.

L&S

THE MARK CONSISTS OF STANDARD CHARACTERS WITHOUT CLAIM TO ANY PARTICULAR FONT, STYLE, SIZE, OR COLOR.

FOR INSURANCE SERVICES, NAMELY, PROVIDING INFORMATION AND ON-LINE COMPUTER DATABASES FOR THE PURPOSE OF REVIEW AND VERIFICATION OF MEDICAID AND MEDICARE ELIGIBILITY STATUS AND RELATED INFORMATION (U.S. CLS. 100, 101 AND 102).

FIRST USE 8-1-2011; IN COMMERCE 8-1-2011.
TRICIA SONNEBORN, EXAMINING ATTORNEY

SN 85-433,431. KRUSE, ROGER, MINNEAPOLIS, MN. FILED 9-27-2011.



NO CLAIM IS MADE TO THE EXCLUSIVE RIGHT TO USE "WEALTH MANAGEMENT", APART FROM THE MARK AS SHOWN.

THE COLOR(S) GOLD, WHITE, BLUE AND GRAY IS/ ARE CLAIMED AS A FEATURE OF THE MARK.

THE MARK CONSISTS OF A GOLD RIGHT TRIANGLE WITH THREE WHITE LINES INTERSECTING THE INTERIOR OF THE TRIANGLE; THE LETTERS "FFP" IN BLUE APPEAR IMMEDIATELY TO THE RIGHT OF THE TRIANGLE; THE WORDS "WEALTH" AND "MANAGEMENT" IN BLUE APPEAR IMMEDIATELY TO THE RIGHT OF THE LETTERS "FFP" AND A GRAY VERTICAL LINE IS LOCATED BETWEEN THE LETTERS "FFP" AND THE WORDS "WEALTH" AND "MANAGEMENT".

FOR ADVICE RELATING TO INVESTMENTS; ESTATE TRUST MANAGEMENT; FINANCIAL TRUST PLANNING (U.S. CLS. 100, 101 AND 102).

FIRST USE 8-22-2011; IN COMMERCE 8-22-2011.
GIANCARLO CASTRO, EXAMINING ATTORNEY

CLASS 36—(Continued).

SN 85-436,902. GIVE REALTY, INCORPORATED, AUSTIN, TX. FILED 9-30-2011.



NO CLAIM IS MADE TO THE EXCLUSIVE RIGHT TO USE "REALTY", APART FROM THE MARK AS SHOWN.

THE MARK CONSISTS OF A PENCILED HOUSE SITTING ON AN UPWARD CURVED INCLINE RESEMBLING A HILL, A CUT OUT HEART REPLACES WHAT WOULD BE A DOOR HANDLE ON THE HOUSE; SITUATED DIRECTLY BELOW THE PENCILED HOUSE ARE THE STYLIZED LETTERS "G I V E" AND DIRECTLY BELOW THOSE LETTERS ARE THE STYLIZED CAPITALIZED LETTERS "R E A L T Y".

FOR REAL ESTATE BROKERAGE (U.S. CLS. 100, 101 AND 102).

FIRST USE 7-17-2008; IN COMMERCE 7-23-2008.
ERIN FALK, EXAMINING ATTORNEY

SN 85-438,932. AUXOL CAPITAL, LLC, BOCA RATON, FL. FILED 10-4-2011.

TEKESTA CAPITAL PARTNERS

THE MARK CONSISTS OF STANDARD CHARACTERS WITHOUT CLAIM TO ANY PARTICULAR FONT, STYLE, SIZE, OR COLOR.

NO CLAIM IS MADE TO THE EXCLUSIVE RIGHT TO USE "CAPITAL PARTNERS", APART FROM THE MARK AS SHOWN.

FOR INVESTMENT BANKING SERVICES (U.S. CLS. 100, 101 AND 102).

MATTHEW KLINE, EXAMINING ATTORNEY

CLASS 36—(Continued).

SN 85-440,530. MICHIGAN COMMUNITY INSURANCE AGENCY, INC., NORTHVILLE, MI. FILED 10-6-2011.



THE MARK CONSISTS OF A SOLID BOX WITH ROUNDED EDGES WHEREIN A REPRESENTATION OF A LIGHT HOUSE IS CUT FROM THE INSIDE OF THE BOX.

FOR INDEPENDENT INSURANCE SERVICES, NAMELY, INSURANCE AGENCIES (U.S. CLS. 100, 101 AND 102).

FIRST USE 6-0-1996; IN COMMERCE 6-0-1996.
JOHN DWYER, EXAMINING ATTORNEY

SN 85-440,698. WEALTHCARE CAPITAL MANAGEMENT IP, LLC, RICHMOND, VA. FILED 10-6-2011.

DEFY THE COMMON

THE MARK CONSISTS OF STANDARD CHARACTERS WITHOUT CLAIM TO ANY PARTICULAR FONT, STYLE, SIZE, OR COLOR.

FOR FINANCIAL PLANNING, FINANCIAL ANALYSIS, AND FINANCIAL ADVISING SERVICES (U.S. CLS. 100, 101 AND 102).

MICHELLE DUBOIS, EXAMINING ATTORNEY

SN 85-440,852. BLUFI LENDING CORPORATION, CARLSBAD, CA. FILED 10-6-2011.

BluFi Direct Mortgage

THE MARK CONSISTS OF STANDARD CHARACTERS WITHOUT CLAIM TO ANY PARTICULAR FONT, STYLE, SIZE, OR COLOR.

NO CLAIM IS MADE TO THE EXCLUSIVE RIGHT TO USE "DIRECT MORTGAGE", APART FROM THE MARK AS SHOWN.

FOR MORTGAGE LENDING (U.S. CLS. 100, 101 AND 102).

FIRST USE 1-20-2009; IN COMMERCE 1-20-2009.
MICHELE SWAIN, EXAMINING ATTORNEY

CLASS 36—(Continued).

SN 85-440,861. BLUFI LENDING CORPORATION, CARLSBAD, CA. FILED 10-6-2011.

BluFi Realty

THE MARK CONSISTS OF STANDARD CHARACTERS WITHOUT CLAIM TO ANY PARTICULAR FONT, STYLE, SIZE, OR COLOR.

NO CLAIM IS MADE TO THE EXCLUSIVE RIGHT TO USE "REALTY", APART FROM THE MARK AS SHOWN.

FOR REAL ESTATE AGENCIES (U.S. CLS. 100, 101 AND 102).

MICHELE SWAIN, EXAMINING ATTORNEY

SN 85-440,999. KEMPER CORPORATION, CHICAGO, IL. FILED 10-6-2011.



NO CLAIM IS MADE TO THE EXCLUSIVE RIGHT TO USE "MUTUAL SAVINGS FIRE INSURANCE", APART FROM THE MARK AS SHOWN.

THE MARK CONSISTS OF A SOLID TRIANGLE AND A LINED TRIANGLE, CREATING THE IMPRESSION OF THE LETTER "K", AND THE WORDING "MUTUAL SAVINGS" TO THE RIGHT OF THE TRIANGLES WITH THE WORDING "FIRE INSURANCE" DIRECTLY BELOW.

FOR INSURANCE UNDERWRITING SERVICES IN THE FIELD OF PROPERTY INSURANCE (U.S. CLS. 100, 101 AND 102).

PAUL MORENO, EXAMINING ATTORNEY

SN 85-441,003. KEMPER CORPORATION, CHICAGO, IL. FILED 10-6-2011.



NO CLAIM IS MADE TO THE EXCLUSIVE RIGHT TO USE "MUTUAL SAVINGS FIRE INSURANCE", APART FROM THE MARK AS SHOWN.

THE MARK CONSISTS OF TWO SOLID TRIANGLES, CREATING THE IMPRESSION OF THE LETTER "K", AND THE WORDING "MUTUAL SAVINGS" TO THE RIGHT OF THE TRIANGLES WITH THE WORDING "FIRE INSURANCE" DIRECTLY BELOW.

FOR INSURANCE UNDERWRITING SERVICES IN THE FIELD OF PROPERTY INSURANCE (U.S. CLS. 100, 101 AND 102).

PAUL MORENO, EXAMINING ATTORNEY

CLASS 36—(Continued).

SN 85-441,040. KEMPER CORPORATION, CHICAGO, IL.
FILED 10-6-2011.



NO CLAIM IS MADE TO THE EXCLUSIVE RIGHT TO USE "CASUALTY INSURANCE", APART FROM THE MARK AS SHOWN.

THE MARK CONSISTS OF A SOLID TRIANGLE AND A LINED TRIANGLE, CREATING THE IMPRESSION OF THE LETTER "K", AND THE WORDING "UNITED CASUALTY" TO THE RIGHT OF THE TRIANGLES WITH THE WORDING "INSURANCE" DIRECTLY BELOW.

FOR INSURANCE UNDERWRITING SERVICES IN THE FIELD OF PROPERTY INSURANCE (U.S. CLS. 100, 101 AND 102).

PAUL MORENO, EXAMINING ATTORNEY

SN 85-441,041. KEMPER CORPORATION, CHICAGO, IL.
FILED 10-6-2011.



NO CLAIM IS MADE TO THE EXCLUSIVE RIGHT TO USE "CASUALTY INSURANCE", APART FROM THE MARK AS SHOWN.

THE MARK CONSISTS OF TWO SOLID TRIANGLES, CREATING THE IMPRESSION OF THE LETTER "K", AND THE WORDING "UNITED CASUALTY" TO THE RIGHT OF THE TRIANGLES WITH THE WORDING "INSURANCE" DIRECTLY BELOW.

FOR INSURANCE UNDERWRITING SERVICES IN THE FIELD OF PROPERTY INSURANCE (U.S. CLS. 100, 101 AND 102).

PAUL MORENO, EXAMINING ATTORNEY

CLASS 36—(Continued).

SN 85-441,259. PAYZID LLC, WOODLAND HILLS, CA.
FILED 10-6-2011.

PAYZID

THE MARK CONSISTS OF STANDARD CHARACTERS WITHOUT CLAIM TO ANY PARTICULAR FONT, STYLE, SIZE, OR COLOR.

FOR FINANCIAL SERVICES, NAMELY, BANKING AND CREDIT CARD SERVICES; PROVIDING CREDIT CARD, DEBIT CARD, AND CHARGE CARD SERVICES, AND ISSUING STORED VALUE CARDS; BANKING SERVICES; BILL PAYMENT SERVICES; CREDIT CARD SERVICES; DEBIT CARD SERVICES; CREDIT AND CHARGE CARD SERVICES; ELECTRONIC CASH DISBURSEMENT TRANSACTIONS, NAMELY, ON-LINE CASH ACCOUNT SERVICES; FINANCIAL SERVICES, NAMELY, PROVIDING ONLINE STORED VALUE ACCOUNTS IN AN ELECTRIC ENVIRONMENT; AUTOMATED TELLER MACHINE SERVICES; ELECTRONIC PAYMENT, NAMELY, ELECTRONIC PROCESSING AND TRANSMISSION OF BILL PAYMENT DATA; ON-LINE BANKING SERVICES; FINANCIAL TRANSACTION SERVICES, NAMELY, PROVIDING SECURE COMMERCIAL TRANSACTIONS AND PAYMENT OPTIONS USING A MOBILE DEVICE AT A POINT OF SALE; ELECTRONIC PAYMENT, NAMELY, ELECTRONIC PAYMENT, NAMELY, ELECTRONIC PROCESSING AND TRANSMISSION OF BILL PAYMENT VIA AUTOMATIC TELLER MACHINES; ISSUING OF TRAVELERS CHECKS; CHECK VERIFICATION; CHECK CASHING; ELECTRONIC FUNDS TRANSFER; CURRENCY EXCHANGE AND ADVICE; PROVIDING FINANCIAL INFORMATION VIA THE INTERNET AND OTHER COMPUTER NETWORKS; PREPAID TELEPHONE CALLING CARD SERVICES (U.S. CLS. 100, 101 AND 102).

ALEX KEAM, EXAMINING ATTORNEY

SN 85-441,368. BLUFI LENDING CORPORATION, CARLSBAD, CA. FILED 10-6-2011.

BluFi Mortgage

THE MARK CONSISTS OF STANDARD CHARACTERS WITHOUT CLAIM TO ANY PARTICULAR FONT, STYLE, SIZE, OR COLOR.

NO CLAIM IS MADE TO THE EXCLUSIVE RIGHT TO USE "MORTGAGE", APART FROM THE MARK AS SHOWN.

FOR MORTGAGE LENDING (U.S. CLS. 100, 101 AND 102).

MICHELE SWAIN, EXAMINING ATTORNEY

CLASS 36—(Continued).

SN 85-441,371. BLUFI LENDING CORPORATION, CARLSBAD, CA. FILED 10-6-2011.

BluFi Loans

THE MARK CONSISTS OF STANDARD CHARACTERS WITHOUT CLAIM TO ANY PARTICULAR FONT, STYLE, SIZE, OR COLOR.

NO CLAIM IS MADE TO THE EXCLUSIVE RIGHT TO USE "LOANS", APART FROM THE MARK AS SHOWN. FOR MORTGAGE LENDING (U.S. CLS. 100, 101 AND 102).

MICHELE SWAIN, EXAMINING ATTORNEY

SN 85-441,383. BLUFI LENDING CORPORATION, CARLSBAD, CA. FILED 10-6-2011.

BluFi Home Loans

THE MARK CONSISTS OF STANDARD CHARACTERS WITHOUT CLAIM TO ANY PARTICULAR FONT, STYLE, SIZE, OR COLOR.

NO CLAIM IS MADE TO THE EXCLUSIVE RIGHT TO USE "HOME LOANS", APART FROM THE MARK AS SHOWN.

FOR MORTGAGE LENDING (U.S. CLS. 100, 101 AND 102).

MICHELE SWAIN, EXAMINING ATTORNEY

SN 85-442,592. ROWAYTON WOODS CONDOMINIUM ASSOCIATION, INC., AKA ROWAYTON WOODS, EAST HARTFORD, CT. FILED 10-7-2011.

Rowayton Woods Condominium Association, Inc.

THE MARK CONSISTS OF STANDARD CHARACTERS WITHOUT CLAIM TO ANY PARTICULAR FONT, STYLE, SIZE, OR COLOR.

NO CLAIM IS MADE TO THE EXCLUSIVE RIGHT TO USE "ROWAYTON" AND "CONDOMINIUM ASSOCIATION, INC.", APART FROM THE MARK AS SHOWN.

FOR REAL ESTATE SERVICES, NAMELY, CONDOMINIUM MANAGEMENT SERVICES (U.S. CLS. 100, 101 AND 102).

FIRST USE 8-25-1978; IN COMMERCE 8-25-1978.
DOUGLAS LEE, EXAMINING ATTORNEY

CLASS 36—(Continued).

SN 85-443,054. PI BETA PHI FRATERNITY, TOWN & COUNTRY, MO. FILED 10-10-2011.



OWNER OF U.S. REG. NOS. 3,135,560, 3,781,017 AND OTHERS.

NO CLAIM IS MADE TO THE EXCLUSIVE RIGHT TO USE "LITERACY INITIATIVES", APART FROM THE MARK AS SHOWN.

THE MARK CONSISTS OF A CIRCULAR DESIGN CONTAINING AN UPWARD-POINTING ARROW AND A FANCIFUL REPRESENTATION OF A BOOK, ENCIRCLING THE DESIGN IN THE WORDING "READ. LEAD. ACHIEVE." ON THE UPPER HALF, AND "PI BETA PHI'S LITERACY INITIATIVES" ON THE LOWER HALF.

FOR ACCEPTING AND ADMINISTERING MONETARY CHARITABLE CONTRIBUTIONS; CHARITABLE FUNDRAISING; CHARITABLE FUNDRAISING TO SUPPORT THE PROMOTION OF LITERACY; PHILANTHROPIC SERVICES CONCERNING MONETARY DONATIONS (U.S. CLS. 100, 101 AND 102).

FIRST USE 6-0-2011; IN COMMERCE 6-0-2011.

JASON BLAIR, EXAMINING ATTORNEY

SN 85-445,155. WILSON, DAWN MARGARET, ROLLING HILLS ESTATES, CA. FILED 10-12-2011.

Face of Humanity

THE MARK CONSISTS OF STANDARD CHARACTERS WITHOUT CLAIM TO ANY PARTICULAR FONT, STYLE, SIZE, OR COLOR.

FOR FUNDRAISING SERVICES, NAMELY, ORGANIZING, ARRANGING AND CONDUCTING FUNDRAISING PROGRAMS FOR THE BENEFIT OF NON-PROFIT ORGANIZATIONS (U.S. CLS. 100, 101 AND 102).

RUDY R. SINGLETON, EXAMINING ATTORNEY

CLASS 36—(Continued).

SN 85-445,195. ALPHA2 PARTNERS, LLC, ROGERS, AR. FILED 10-12-2011.



THE COLOR(S) BLUE, GREEN AND RED IS/ARE CLAIMED AS A FEATURE OF THE MARK.

THE MARK CONSISTS OF THE WORD "ALPHA" WITH ALL LETTERS IN BLUE EXCEPT FOR THE LETTER "P" WHICH IS IN GREEN, IMMEDIATELY FOLLOWED BY A RED NUMBER "2" IN SUPERSCRIPIT.

FOR FINANCIAL PLANNING AND INVESTMENT ADVISORY SERVICES (U.S. CLS. 100, 101 AND 102).
DAVID I, EXAMINING ATTORNEY

CLASS 36—(Continued).

SN 85-445,474. AMERICAN ECONOMIC PLANNING GROUP, INC., WARREN, NJ. FILED 10-12-2011.



THE MARK CONSISTS OF STANDARD CHARACTERS WITHOUT CLAIM TO ANY PARTICULAR FONT, STYLE, SIZE, OR COLOR.

FOR ADMINISTRATION OF EMPLOYEE BENEFIT PLANS CONCERNING INSURANCE AND FINANCE; CONSULTING AND INFORMATION CONCERNING INSURANCE; CONSULTING SERVICES IN THE FIELD OF RETIREMENT PLAN ADMINISTRATION AND FIDUCIARY COMPLIANCE; CONSULTING SERVICES IN THE FIELD OF STATE AND FEDERAL EMPLOYEE BENEFIT PLANS CONCERNING INSURANCE AND FINANCE; DESIGN AND DEVELOPMENT OF INSURANCE POLICIES FOR OTHERS; ESTATE PLANNING; ESTATE TRUST PLANNING; FINANCIAL ADMINISTRATION OF RETIREMENT PLANS; FINANCIAL PLANNING; FINANCIAL PLANNING AND INVESTMENT ADVISORY SERVICES; FINANCIAL PLANNING CONSULTATION; INSURANCE ADMINISTRATION; INSURANCE BROKERAGE; INSURANCE INFORMATION AND CONSULTANCY; INVESTMENT MANAGEMENT; PROVIDING INFORMATION IN THE FIELD OF EMPLOYEE FINANCIAL BENEFIT PLANS (U.S. CLS. 100, 101 AND 102).

FIRST USE 3-21-1983; IN COMMERCE 3-21-1983.
DEIRDRE ROBERTSON, EXAMINING ATTORNEY

SN 85-445,237. THE GRACE TRUST, INC., WINONA LAKE, IN. FILED 10-12-2011.

ENCOMPASS WORLD PARTNERS

THE MARK CONSISTS OF STANDARD CHARACTERS WITHOUT CLAIM TO ANY PARTICULAR FONT, STYLE, SIZE, OR COLOR.

FOR CHARITABLE FUNDRAISING SERVICES FOR MISSIONARY AND HUMANITARIAN WORK IN SPREADING THE CHRISTIAN GOSPEL AND SERVING ACCORDING TO THE CHRISTIAN FAITH, FOR RELIGIOUS ORGANIZATIONS, AND FOR PROGRAMS FOR THE POOR, NAMELY PROGRAMS FOR THE POOR WHICH PROVIDE CLOTHING, MEDICAL CARE, SCHOOLS, HOUSING, AGRICULTURAL PROGRAMS AND OTHER HUMANITARIAN ASSISTANCE TO THE POOR AND NEEDY (U.S. CLS. 100, 101 AND 102).
LEIGH CAROLINE CASE, EXAMINING ATTORNEY

SN 85-445,491. AMERICAN ECONOMIC PLANNING GROUP, INC., WARREN, NJ. FILED 10-12-2011.

CONSISTENTLY GOOD ADVICE
IN A CONSTANTLY CHANGING
WORLD

THE MARK CONSISTS OF STANDARD CHARACTERS WITHOUT CLAIM TO ANY PARTICULAR FONT, STYLE, SIZE, OR COLOR.

FOR ADMINISTRATION OF EMPLOYEE BENEFIT PLANS CONCERNING INSURANCE AND FINANCE; CONSULTING AND INFORMATION CONCERNING INSURANCE; CONSULTING SERVICES IN THE FIELD OF RETIREMENT PLAN ADMINISTRATION AND FIDUCIARY COMPLIANCE; CONSULTING SERVICES IN THE FIELD OF STATE AND FEDERAL EMPLOYEE BENEFIT PLANS CONCERNING INSURANCE AND FINANCE; DESIGN AND DEVELOPMENT OF INSURANCE POLICIES FOR OTHERS; ESTATE PLANNING; ESTATE TRUST PLANNING; FINANCIAL ADMINISTRATION OF RETIREMENT PLANS; FINANCIAL PLANNING; FINANCIAL PLANNING AND INVESTMENT ADVISORY SERVICES; FINANCIAL PLANNING CONSULTATION; INSURANCE ADMINISTRATION; INSURANCE BROKERAGE; INSURANCE INFORMATION AND CONSULTANCY; INVESTMENT MANAGEMENT; PROVIDING INFORMATION IN THE FIELD OF EMPLOYEE FINANCIAL BENEFIT PLANS (U.S. CLS. 100, 101 AND 102).

FIRST USE 0-0-2009; IN COMMERCE 0-0-2009.
DEIRDRE ROBERTSON, EXAMINING ATTORNEY

CLASS 36—(Continued).

SN 85-445,519. PROFESSIONAL EDGE FISHING INC., PITTSBORO, NJ. FILED 10-12-2011.

THE IKE FOUNDATION

THE MARK CONSISTS OF STANDARD CHARACTERS WITHOUT CLAIM TO ANY PARTICULAR FONT, STYLE, SIZE, OR COLOR.

NO CLAIM IS MADE TO THE EXCLUSIVE RIGHT TO USE "FOUNDATION", APART FROM THE MARK AS SHOWN.

THE NAME(S), PORTRAIT(S), AND/OR SIGNATURE(S) SHOWN IN THE MARK IDENTIFIES MICHAEL IACONELLI, WHOSE CONSENT(S) TO REGISTER IS MADE OF RECORD.

FOR CHARITABLE FUNDRAISING TO SUPPORT THE COLLECTION AND DISTRIBUTION OF NEW AND USED FISHING EQUIPMENT AND OTHER SPORTING GOODS EQUIPMENT TO ENTRY-LEVEL FISHERMEN AND OTHER ATHLETES FOR THE BENEFIT OF SPORTS AND ATHLETIC ENDEAVORS (U.S. CLS. 100, 101 AND 102).

ANDREA HACK, EXAMINING ATTORNEY

SN 85-445,525. ROBERT SHEMIN WORLDWIDE, NASHVILLE, TN. FILED 10-12-2011.

Robert Shemin

THE MARK CONSISTS OF STANDARD CHARACTERS WITHOUT CLAIM TO ANY PARTICULAR FONT, STYLE, SIZE, OR COLOR.

THE NAME "ROBERT SHEMIN" IDENTIFIES A LIVING INDIVIDUAL WHOSE CONSENT IS OF RECORD.

FOR INVESTMENT ADVICE IN THE FIELD OF REAL ESTATE (U.S. CLS. 100, 101 AND 102).

FIRST USE 6-10-1963; IN COMMERCE 6-10-1963.
LINDA E. BLOHM, EXAMINING ATTORNEY

SN 85-445,592. ALABAMA HOUSING FINANCE AUTHORITY, MONTGOMERY, AL. FILED 10-12-2011.

SERVISOLUTIONS

THE MARK CONSISTS OF STANDARD CHARACTERS WITHOUT CLAIM TO ANY PARTICULAR FONT, STYLE, SIZE, OR COLOR.

FOR MAINTAINING MORTGAGE ESCROW ACCOUNTS; MORTGAGE BANKING SERVICES, NAMELY, ORIGINATION, ACQUISITION, SERVICING, SECURITIZATION AND BROKERAGE OF MORTGAGE LOANS; MORTGAGE FORECLOSURE SERVICES (U.S. CLS. 100, 101 AND 102).

AMY HELLA, EXAMINING ATTORNEY

CLASS 36—(Continued).

SN 85-445,671. CASH SYSTEMS, INC., LAS VEGAS, NV. FILED 10-12-2011.

TABLECASH

THE MARK CONSISTS OF STANDARD CHARACTERS WITHOUT CLAIM TO ANY PARTICULAR FONT, STYLE, SIZE, OR COLOR.

THE WORDING "TABLECASH" HAS NO MEANING IN A FOREIGN LANGUAGE.

FOR FINANCIAL SERVICES, NAMELY, CASH DISPENSING TRANSACTIONS, CURRENCY EXCHANGE, CHECK CASHING, MONEY WIRE TRANSFERS, CASH ADVANCES, DEBIT, NAMELY, ELECTRONIC DEBIT TRANSACTIONS AND DEPOSITS, NAMELY, DELAYED DEPOSIT TRANSACTIONS AND MONEY LENDING; AUTOMATED TELLER MACHINE SERVICES (U.S. CLS. 100, 101 AND 102).

STEVEN JACKSON, EXAMINING ATTORNEY

SN 85-445,721. FCOA, LLC, CALEDONIA, MI. FILED 10-12-2011.

GO AHEAD. EXPECT MORE.

THE MARK CONSISTS OF STANDARD CHARACTERS WITHOUT CLAIM TO ANY PARTICULAR FONT, STYLE, SIZE, OR COLOR.

FOR PROPERTY AND CASUALTY INSURANCE UNDERWRITING SERVICES; INSURANCE CLAIMS PROCESSING, INSURANCE CLAIMS ADMINISTRATION, AND INSURANCE AGENCIES; PROVIDING INFORMATION IN INSURANCE MATTERS (U.S. CLS. 100, 101 AND 102).

FIRST USE 9-0-2009; IN COMMERCE 9-0-2009.
BENJAMIN OKEKE, EXAMINING ATTORNEY

SN 85-445,819. POKALSKY, MICHAEL, LEVITTOWN, NY. FILED 10-12-2011.

NEPALA

THE MARK CONSISTS OF STANDARD CHARACTERS WITHOUT CLAIM TO ANY PARTICULAR FONT, STYLE, SIZE, OR COLOR.

THE WORDING "NEPALA" HAS NO MEANING IN A FOREIGN LANGUAGE.

FOR LEASING OF REAL ESTATE; LEASING OF FARMS; LEASING OF RURAL PROPERTY FOR OIL AND GAS EXPLORATION AND DEVELOPMENT (U.S. CLS. 100, 101 AND 102).

FIRST USE 5-16-2008; IN COMMERCE 5-16-2008.
AMY KELLY, EXAMINING ATTORNEY

CLASS 36—(Continued).

SN 85-446,233. PREMIER MEMBERS FEDERAL CREDIT UNION, BOULDER, CO. FILED 10-13-2011.

Better banking through cooperation

THE MARK CONSISTS OF STANDARD CHARACTERS WITHOUT CLAIM TO ANY PARTICULAR FONT, STYLE, SIZE, OR COLOR.

FOR BANKING; BANKING AND FINANCING SERVICES; BANKING SERVICES (U.S. CLS. 100, 101 AND 102).

MICHAEL ENGEL, EXAMINING ATTORNEY

SN 85-446,270. EASY STREET REALTY, INC., INDIANAPOLIS, IN. FILED 10-13-2011.

HIGHGARDEN REAL ESTATE

THE MARK CONSISTS OF STANDARD CHARACTERS WITHOUT CLAIM TO ANY PARTICULAR FONT, STYLE, SIZE, OR COLOR.

NO CLAIM IS MADE TO THE EXCLUSIVE RIGHT TO USE "REAL ESTATE", APART FROM THE MARK AS SHOWN.

FOR LEASING OF REAL ESTATE; REAL ESTATE AGENCIES; REAL ESTATE BROKERAGE (U.S. CLS. 100, 101 AND 102).

MARK RADEMACHER, EXAMINING ATTORNEY

SN 85-446,280. EASY STREET REALTY, INC., INDIANAPOLIS, IN. FILED 10-13-2011.



NO CLAIM IS MADE TO THE EXCLUSIVE RIGHT TO USE "REAL ESTATE", APART FROM THE MARK AS SHOWN.

THE MARK CONSISTS OF THE LETTER "H" CONSISTING OF A HOME WITH TWO DIMENSIONAL ROOF PITCHES THAT COMPRISES THE MIDDLE HORIZONTAL LINE OF THE "H". UNDERNEATH THE "H" IS THE WORD "HIGHGARDEN" ABOVE THE WORDS "REAL ESTATE".

FOR LEASING OF REAL ESTATE; REAL ESTATE AGENCIES; REAL ESTATE BROKERAGE (U.S. CLS. 100, 101 AND 102).

MARK RADEMACHER, EXAMINING ATTORNEY

CLASS 36—(Continued).

SN 85-446,282. PREMIER MEMBERS FEDERAL CREDIT UNION, BOULDER, CO. FILED 10-13-2011.

Working together to make banking better

THE MARK CONSISTS OF STANDARD CHARACTERS WITHOUT CLAIM TO ANY PARTICULAR FONT, STYLE, SIZE, OR COLOR.

FOR BANKING; BANKING AND FINANCING SERVICES; BANKING SERVICES (U.S. CLS. 100, 101 AND 102).

MICHAEL ENGEL, EXAMINING ATTORNEY

SN 85-446,378. COAST 2 COAST TELECOM CORPORATION, P/PEMBROKE PINES, FL. FILED 10-13-2011.

LLENA y BAILA

THE MARK CONSISTS OF STANDARD CHARACTERS WITHOUT CLAIM TO ANY PARTICULAR FONT, STYLE, SIZE, OR COLOR.

THE ENGLISH TRANSLATION OF THE WORD "LLENA Y BAILA" IN THE MARK IS "FILL AND DANCE".

FOR PREPAID SERVICES IN THE NATURE OF MAKING ADVANCE PAYMENTS TO ADD VALUE TO PREPAID OR PAY-AS-YOU-GO CARDS FOR THE PURCHASE OF DIGITAL MUSIC (U.S. CLS. 100, 101 AND 102).

MIDGE BUTLER, EXAMINING ATTORNEY

SN 85-446,392. BLUFI LENDING CORPORATION, CARLSBAD, CA. FILED 10-13-2011.

BluFi Real Estate

THE MARK CONSISTS OF STANDARD CHARACTERS WITHOUT CLAIM TO ANY PARTICULAR FONT, STYLE, SIZE, OR COLOR.

NO CLAIM IS MADE TO THE EXCLUSIVE RIGHT TO USE "REAL ESTATE", APART FROM THE MARK AS SHOWN.

FOR REAL ESTATE AGENCIES (U.S. CLS. 100, 101 AND 102).

MICHELE SWAIN, EXAMINING ATTORNEY

CLASS 36—(Continued).

SN 85-446,394. THE HOME SAVINGS AND LOAN COMPANY OF YOUNGSTOWN, OHIO, YOUNGSTOWN, OH. FILED 10-13-2011.

MAKE YOURSELF AT HOME!

THE MARK CONSISTS OF STANDARD CHARACTERS WITHOUT CLAIM TO ANY PARTICULAR FONT, STYLE, SIZE, OR COLOR.

FOR ADMINISTRATION OF SAVINGS ACCOUNTS; CASH MANAGEMENT SERVICES; BANKING; BILL PAYMENT SERVICES; CHECK CASHING; CHECKING ACCOUNT SERVICES; CONSUMER LENDING SERVICES; FINANCIAL LOAN CONSULTATION; FINANCIAL MANAGEMENT; FINANCIAL PLANNING; FINANCIAL SERVICES IN THE FIELD OF MONEY LENDING; FINANCIAL SERVICES, NAMELY, MORTGAGE PLANNING; HOME EQUITY LOANS; INVESTMENT ADVICE; INVESTMENT CONSULTATION; INVESTMENT MANAGEMENT; ISSUANCE OF BANK CHECKS; LOAN FINANCING; MORTGAGE BANKING; MORTGAGE LENDING; MORTGAGE SERVICES, NAMELY, BUYER PRE-QUALIFICATION FOR MORTGAGE LOANS; ON-LINE BANKING SERVICES; SAVINGS ACCOUNT SERVICES; SAVINGS AND LOAN SERVICES; SAVINGS BANK SERVICES (U.S. CLS. 100, 101 AND 102).

FIRST USE 10-12-2011; IN COMMERCE 10-12-2011.
GIANCARLO CASTRO, EXAMINING ATTORNEY

SN 85-446,406. COAST 2 COAST TELECOM CORPORATION, PEMBROKE PINES, FL. FILED 10-13-2011.

LLENA y CANTA

THE MARK CONSISTS OF STANDARD CHARACTERS WITHOUT CLAIM TO ANY PARTICULAR FONT, STYLE, SIZE, OR COLOR.

THE ENGLISH TRANSLATION OF "LLENA Y CANTA" IN THE MARK IS "FILL AND SING".

FOR PREPAID SERVICES IN THE NATURE OF MAKING ADVANCE PAYMENTS TO ADD VALUE TO PREPAID OR PAY-AS-YOU-GO CARDS FOR THE PURCHASE OF DIGITAL MUSIC (U.S. CLS. 100, 101 AND 102).

MIDGE BUTLER, EXAMINING ATTORNEY

CLASS 36—(Continued).

SN 85-446,427. COAST 2 COAST TELECOM CORPORATION, PEMBROKE PINES, FL. FILED 10-13-2011.

CANTA y BAILA

THE MARK CONSISTS OF STANDARD CHARACTERS WITHOUT CLAIM TO ANY PARTICULAR FONT, STYLE, SIZE, OR COLOR.

OWNER OF U.S. REG. NO. 4,048,898.

THE ENGLISH TRANSLATION OF "CANTA Y BAILA" IN THE MARK IS "SING AND DANCE".

FOR PREPAID SERVICES IN THE NATURE OF MAKING ADVANCE PAYMENTS TO ADD VALUE TO PREPAID OR PAY-AS-YOU-GO CARDS FOR THE PURCHASE OF DIGITAL MUSIC (U.S. CLS. 100, 101 AND 102).

MICHAEL GAAFAR, EXAMINING ATTORNEY

SN 85-446,432. STUECK, DAVID, WENATCHEE, WA. FILED 10-13-2011.



NO CLAIM IS MADE TO THE EXCLUSIVE RIGHT TO USE "NW" AND "NW COMMERCIAL BROKERS", APART FROM THE MARK AS SHOWN.

THE MARK CONSISTS OF BUILDINGS IN THE BACKGROUND WITH A LARGE "NW" ACROSS AND OVER THE BUILDINGS, AND THE TEXT "NW COMMERCIAL BROKERS" SPELLED OUT BELOW THE LOGO.

FOR REAL ESTATE BROKERAGE (U.S. CLS. 100, 101 AND 102).

AMY ALFIERI, EXAMINING ATTORNEY

CLASS 36—(Continued).

SN 85-446,436. DILLON, BETTY D., ROCHELLE, VA. FILED 10-13-2011.



THE MARK CONSISTS OF A CIRCLE CONTAINING THE TEXT "HOOFIN' FOR HEROES" CURVED ACROSS THE TOP AND AN UPWARDS FACING HORSESHOE WITH DOG TAGS ATTACHED TO THE UPPER RIGHT PORTION OF HORSESHOE BELOW THE TEXT.

FOR CHARITABLE FUNDRAISING SERVICES BY MEANS OF ORGANIZING AND CONDUCTING SPECIAL EVENTS FOR MILITARY AND VETERANS (U.S. CLS. 100, 101 AND 102).

FIRST USE 10-1-2008; IN COMMERCE 10-1-2008.
ARETHA SOMERVILLE, EXAMINING ATTORNEY

SN 85-446,437. COAST TO COAST TELECOM CORPORATION, PEMBROKE PINES, FL. FILED 10-13-2011.

Praise and Share

THE MARK CONSISTS OF STANDARD CHARACTERS WITHOUT CLAIM TO ANY PARTICULAR FONT, STYLE, SIZE, OR COLOR.

FOR PREPAID SERVICES IN THE NATURE OF MAKING ADVANCE PAYMENTS TO ADD VALUE TO PREPAID OR PAY-AS-YOU-GO CARDS FOR THE PURCHASE OF DIGITAL MUSIC (U.S. CLS. 100, 101 AND 102).

MICHAEL GAAFAR, EXAMINING ATTORNEY

CLASS 36—(Continued).

SN 85-446,451. COAST 2 COAST TELECOM CORPORATION, PEMBROKE PINES, FL. FILED 10-13-2011.

Sing and Praise

THE MARK CONSISTS OF STANDARD CHARACTERS WITHOUT CLAIM TO ANY PARTICULAR FONT, STYLE, SIZE, OR COLOR.

FOR PREPAID SERVICES IN THE NATURE OF MAKING ADVANCE PAYMENTS TO ADD VALUE TO PREPAID OR PAY-AS-YOU-GO CARDS FOR THE PURCHASE OF DIGITAL MUSIC (U.S. CLS. 100, 101 AND 102).

MIDGE BUTLER, EXAMINING ATTORNEY

SN 85-446,666. COMMUNITY HOSPICE FOUNDATION, ROCKY MOUNT, NC. FILED 10-13-2011.

COMMUNITY HOSPICE FOUNDATION

THE MARK CONSISTS OF STANDARD CHARACTERS WITHOUT CLAIM TO ANY PARTICULAR FONT, STYLE, SIZE, OR COLOR.

OWNER OF U.S. REG. NO. 3,161,203.
NO CLAIM IS MADE TO THE EXCLUSIVE RIGHT TO USE "FOUNDATION", APART FROM THE MARK AS SHOWN.

SEC. 2(F).
FOR NON-PROFIT CHARITABLE ACTIVITIES, NAMELY PROVIDING FINANCIAL SUPPORT TO INDIGENT AND LIMITED MEANS INDIVIDUALS IN NEED OF END-OF-LIFE CARE, AND FUNDRAISING FOR END-OF LIFE CARE (U.S. CLS. 100, 101 AND 102).

FIRST USE 9-30-2004; IN COMMERCE 9-30-2004.
JESSICA A. POWERS, EXAMINING ATTORNEY

SN 85-446,784. KIAN CAPITAL PARTNERS, LLC, CHARLOTTE, NC. FILED 10-13-2011.



NO CLAIM IS MADE TO THE EXCLUSIVE RIGHT TO USE "CAPITAL A PRIVATE INVESTMENT FIRM", APART FROM THE MARK AS SHOWN.

THE MARK CONSISTS OF THE WORDS "KIAN CAPITAL" IN STYLIZED FONT AND THE WORDS "A PRIVATE INVESTMENT FIRM" IN SMALLER TYPE AND UNDERNEATH. ADJACENT TO THE WORDING IS A DESIGN OF A SQUARE COMPRISED OF THE LETTERS "KC".

FOR FINANCIAL SERVICES, NAMELY, PRIVATE EQUITY INVESTMENT AND MEZZANINE INVESTMENT SERVICES; MANAGEMENT OF PRIVATE EQUITY FUNDS (U.S. CLS. 100, 101 AND 102).

FIRST USE 9-22-2011; IN COMMERCE 9-22-2011.
DEIRDRE ROBERTSON, EXAMINING ATTORNEY

CLASS 36—(Continued).

SN 85-446,792. HY-VEE, INC., WEST DES MOINES, IA. FILED 10-13-2011.

Hy-Vee One Step

THE MARK CONSISTS OF STANDARD CHARACTERS WITHOUT CLAIM TO ANY PARTICULAR FONT, STYLE, SIZE, OR COLOR.

OWNER OF U.S. REG. NOS. 3,217,660, 3,217,663 AND OTHERS.

FOR CHARITABLE FUNDRAISING SERVICES, NAMELY, RAISING MONEY FOR COMMUNITIES THROUGH PROMOTIONS AND INCENTIVES (U.S. CLS. 100, 101 AND 102).

DEIRDRE ROBERTSON, EXAMINING ATTORNEY

SN 85-446,817. KIAN CAPITAL PARTNERS, LLC, CHARLOTTE, NC. FILED 10-13-2011.



THE MARK CONSISTS OF A DESIGN OF A SQUARE COMPRISED OF THE LETTERS "KC".

FOR FINANCIAL SERVICES, NAMELY, PRIVATE EQUITY INVESTMENT AND MEZZANINE INVESTMENT SERVICES; MANAGEMENT OF PRIVATE EQUITY FUNDS (U.S. CLS. 100, 101 AND 102).

DEIRDRE ROBERTSON, EXAMINING ATTORNEY

CLASS 36—(Continued).

SN 85-446,907. TOKIO MARINE & NICHIDO FIRE INSURANCE CO., LTD., CHIYODA-KU, TOKYO, JAPAN, FILED 10-13-2011.



OWNER OF U.S. REG. NOS. 2,897,133, 3,892,479 AND OTHERS.

THE MARK CONSISTS OF A SPHERE INSIDE THREE THREE-DIMENSIONAL BANDS, ALL ABOVE THE WORDS "TOKIO MARINE TMR".

SEC. 2(F) AS TO "TOKIO MARINE".

FOR PROPERTY AND CASUALTY REINSURANCE UNDERWRITING; PROPERTY AND CASUALTY INSURANCE UNDERWRITING; INSURANCE AND REINSURANCE CLAIMS ADJUSTING; INSURANCE AND REINSURANCE ACTUARIAL SERVICES; INSURANCE AND REINSURANCE PREMIUM RATE COMPUTING SERVICES; INSURANCE AND REINSURANCE INFORMATION SERVICES; INSURANCE AND REINSURANCE CONSULTANCY SERVICES; ACTUARIAL SERVICES; REINSURANCE UNDERWRITING (U.S. CLS. 100, 101 AND 102).

FIRST USE 9-11-2006; IN COMMERCE 9-11-2006. CARRIE GENOVESE, EXAMINING ATTORNEY

SN 85-446,962. 93 FINANCIAL GROUP, LLC, WOBURN, MA. FILED 10-13-2011.



OWNER OF U.S. REG. NO. 2,869,785.

THE MARK CONSISTS OF THE NUMBER "93" WITH THE LETTERS "F" AND "G" NEXT TO IT, ALL WRITTEN IN A CURSIVE STYLE AND REVERSED OUT ON A SOLID DARK RECTANGLE. THE RECTANGLE IS SURROUNDED BY A SOLID, DARK BORDER.

FOR FINANCIAL PLANNING AND INVESTMENT ADVISORY SERVICES; INSURANCE AGENCY AND BROKERAGE (U.S. CLS. 100, 101 AND 102).

FIRST USE 8-31-2011; IN COMMERCE 8-31-2011. SHANNON TWOHIG, EXAMINING ATTORNEY

CLASS 36—(Continued).

SN 85-447,211. CERVISIOR LLC, AUSTIN, TX. FILED 10-13-2011.

CLASS 36—(Continued).

SN 85-447,761. OPENARC ASSET MANAGEMENT, LLC, FORMERLY OPENARC CAPITAL MANAGEMENT, LLC, NEW YORK, NY. FILED 10-14-2011.

Pay Next Month

THE MARK CONSISTS OF STANDARD CHARACTERS WITHOUT CLAIM TO ANY PARTICULAR FONT, STYLE, SIZE, OR COLOR.

FOR PROVIDING ELECTRONIC PROCESSING OF ELECTRONIC FUNDS TRANSFER, ACH, CREDIT CARD, DEBIT CARD, ELECTRONIC CHECK AND ELECTRONIC PAYMENTS; PROVIDING PERSONAL LOANS AND LINES OF CREDIT (U.S. CLS. 100, 101 AND 102).

THOMAS MANOR, EXAMINING ATTORNEY

OpenArc Asset Management

SN 85-447,513. GREENVILLE SPORTS & IMPORTS, INC., GREENVILLE, NC. FILED 10-14-2011.

Finance My Autos

THE MARK CONSISTS OF STANDARD CHARACTERS WITHOUT CLAIM TO ANY PARTICULAR FONT, STYLE, SIZE, OR COLOR.

FOR FINANCING AND LOAN SERVICES; FINANCING RELATING TO AUTOMOBILES; PROVIDING INFORMATION IN THE FIELD OF FINANCE (U.S. CLS. 100, 101 AND 102).

FIRST USE 8-1-2009; IN COMMERCE 8-1-2009.
MARK T. MULLEN, EXAMINING ATTORNEY

THE MARK CONSISTS OF STANDARD CHARACTERS WITHOUT CLAIM TO ANY PARTICULAR FONT, STYLE, SIZE, OR COLOR.

NO CLAIM IS MADE TO THE EXCLUSIVE RIGHT TO USE "ASSET MANAGEMENT", APART FROM THE MARK AS SHOWN.

FOR ADVICE RELATING TO INVESTMENTS; FINANCIAL ADVICE; FINANCIAL ADVICE AND CONSULTANCY SERVICES; FINANCIAL PLANNING AND INVESTMENT ADVISORY SERVICES; FINANCIAL SERVICES, NAMELY, A TOTAL PORTFOLIO OFFERING FOR HIGH NET WORTH CLIENTS CONSISTING OF BOTH SEPARATE ACCOUNTS AND MUTUAL FUNDS FOR EQUITY AND FIXED INCOME INVESTMENTS; FINANCIAL SERVICES, NAMELY, INVESTMENT ADVICE, INVESTMENT MANAGEMENT, INVESTMENT CONSULTATION AND INVESTMENT OF FUNDS FOR OTHERS, INCLUDING PRIVATE AND PUBLIC EQUITY AND DEBT INVESTMENT SERVICES; FUNDS INVESTMENT; HEDGE FUND INVESTMENT SERVICES; INFORMATION, ADVISORY, CONSULTANCY AND RESEARCH SERVICES RELATING TO FINANCE AND INVESTMENTS; INVESTMENT ADVICE; INVESTMENT ADVISORY SERVICES; INVESTMENT CONSULTANCY; INVESTMENT CONSULTATION; INVESTMENT MANAGEMENT; INVESTMENT OF FUNDS FOR OTHERS (U.S. CLS. 100, 101 AND 102).

FIRST USE 4-1-2011; IN COMMERCE 4-1-2011.
DEBORAH LOBO, EXAMINING ATTORNEY

CLASS 36—(Continued).

SN 85-447,827. ZACHOR HOLOCAUST REMEMBRANCE FOUNDATION, LAS VEGAS, NV. FILED 10-14-2011.

ZACHOR
זכור
HOLOCAUST
Remembrance
FOUNDATION

NO CLAIM IS MADE TO THE EXCLUSIVE RIGHT TO USE "HOLOCAUST REMEMBRANCE FOUNDATION", APART FROM THE MARK AS SHOWN.

THE MARK CONSISTS OF THE WORDS "ZACHOR HOLOCAUST REMEMBRANCE FOUNDATION" WITH THE WORDS "ZACHOR", "HOLOCAUST", "REMEMBRANCE" AND "FOUNDATION" STACKED HORIZONTALLY, WITH THE WORD "REMEMBER" APPEARING IN HEBREW CHARACTERS BETWEEN THE WORDS "ZACHOR" AND "HOLOCAUST".

THE ENGLISH TRANSLATION OF "ZACHOR" IN THE MARK IS "REMEMBER".

THE NON-LATIN CHARACTERS IN THE MARK TRANSLITERATE TO "ZACHOR" AND THIS MEANS "REMEMBER" IN ENGLISH.

FOR CHARITABLE FOUNDATION SERVICES, NAMELY, PROVIDING FUNDRAISING ACTIVITIES, FUNDING, SCHOLARSHIPS AND/OR FINANCIAL ASSISTANCE FOR SUPPORTING HOLOCAUST REMEMBRANCE AND EDUCATION (U.S. CLS. 100, 101 AND 102).

FIRST USE 1-1-2009; IN COMMERCE 1-1-2009.
 KIMBERLY FRYE, EXAMINING ATTORNEY

SN 85-447,937. EREALTY CONCEPTS, INC., LAS VEGAS, NV. FILED 10-14-2011.

EPRONET

THE MARK CONSISTS OF STANDARD CHARACTERS WITHOUT CLAIM TO ANY PARTICULAR FONT, STYLE, SIZE, OR COLOR.

FOR BUSINESS BROKERAGE SERVICES AND RELATED CONSULTING PERTAINING TO BUSINESS SALES, MERGERS, ACQUISITIONS AND BUSINESS VALUATIONS; CLASSIFIED REAL ESTATE LISTINGS OF APARTMENT RENTALS AND HOUSING RENTALS; COMMERCIAL AND RESIDENTIAL REAL ESTATE AGENCY SERVICES; EVALUATING REAL ESTATE TO ASSESS FEASIBILITY FOR USE AS A PROPERTY SELF-STORAGE FACILITY; ARRANGING OF LEASES AND RENTAL AGREEMENTS FOR REAL ESTATE; ASSESSMENT AND MANAGEMENT OF REAL ESTATE; LAND ACQUISITION, NAMELY, REAL ESTATE BROKERAGE; LEASING OF REAL ESTATE; MORTGAGE FORECLOSURE MITIGATION AND LOAN DEFAULT MITIGATION SERVICES, NAMELY, ACQUISITION AND LEASE-BACK OF REAL ESTATE; PROVIDING A DATABASE OF INFORMATION ABOUT RESIDENTIAL REAL ESTATE LISTINGS; PROVIDING AN INTERNET WEBSITE PORTAL OFFERING INFORMATION IN THE FIELDS

CLASS 36—(Continued).

OF REAL ESTATE CONCERNING THE PURCHASE AND SALE OF NEW, RESALE HOMES, AND CONDOS; PROVIDING INFORMATION IN THE FIELD OF REAL ESTATE BY MEANS OF LINKING THE WEB SITE TO OTHER WEB SITES FEATURING REAL ESTATE INFORMATION; PROVIDING REAL ESTATE LISTINGS AND REAL ESTATE INFORMATION VIA THE INTERNET; REAL ESTATE ACQUISITION SERVICES; REAL ESTATE AGENCIES; REAL ESTATE APPRAISAL AND VALUATION; REAL ESTATE BROKERAGE; REAL ESTATE BROKERAGE SERVICES SPECIALIZING IN RESTAURANTS AND OTHER FOOD SERVICE RELATED BUSINESSES; REAL ESTATE CONSULTATION; REAL ESTATE EQUITY SHARING, NAMELY, MANAGING AND ARRANGING FOR CO-OWNERSHIP OF REAL ESTATE; REAL ESTATE FINANCING SERVICES; REAL ESTATE FUNDS INVESTMENT SERVICES; REAL ESTATE INSURANCE UNDERWRITING SERVICES; REAL ESTATE INVESTMENT SERVICES; REAL ESTATE INVESTMENT SERVICES IN THE NATURE OF PURCHASING AND SELLING OF REAL ESTATE FOR OTHERS; REAL ESTATE INVESTMENT TRUST SERVICES; REAL ESTATE INVESTMENT TRUST MANAGEMENT SERVICES; REAL ESTATE INVESTMENT TRUST ADVISORY SERVICES; REAL ESTATE LENDING SERVICES; REAL ESTATE LISTING; REAL ESTATE LISTING SERVICES FOR HOUSING RENTALS AND APARTMENT RENTALS; REAL ESTATE MANAGEMENT SERVICES; REAL ESTATE MANAGEMENT CONSULTATION; REAL ESTATE MULTIPLE LISTING SERVICES; REAL ESTATE PROCUREMENT FOR OTHERS; REAL ESTATE RENTAL SERVICES, NAMELY, RENTAL OF RESIDENTIAL HOUSING, VACATION HOMES, CONDOMINIUMS, CABINS, AND VILLAS; REAL ESTATE SERVICE, NAMELY, RENTAL PROPERTY MANAGEMENT; REAL ESTATE SERVICES, NAMELY, RENTAL OF SHORT-TERM FURNISHED APARTMENTS; REAL ESTATE SERVICES IN THE FORM OF PROVIDING PHYSICAL ACCESS TO AVAILABLE PROPERTIES VIA A REMOTE CALL-IN LOCKING DEVICE; REAL ESTATE SERVICES TO STOP FORECLOSURE, NAMELY, MORTGAGE DEBT MANAGEMENT; REAL ESTATE SERVICES, NAMELY, PROVIDING ONLINE QUESTIONS TO HELP USERS DETERMINE THE BEST NEIGHBORHOODS AND COMMUNITIES SUITED TO THEIR INDIVIDUAL NEEDS AND PREFERENCES; REAL ESTATE SERVICES, NAMELY, LEASING AND MANAGEMENT FOR OTHERS OF CONDOMINIUMS LOCATED WITHIN HOTEL DEVELOPMENTS; REAL ESTATE SERVICES, NAMELY, VACATION HOME RENTAL MANAGEMENT SERVICES; REAL ESTATE SERVICES, NAMELY, RENTAL, BROKERAGE, LEASING AND MANAGEMENT OF COMMERCIAL PROPERTY, OFFICES AND OFFICE SPACE; REAL ESTATE SERVICES, NAMELY, PROPERTY MANAGEMENT SERVICES FOR CONDOMINIUM ASSOCIATIONS, HOMEOWNER ASSOCIATIONS AND APARTMENT BUILDINGS; REAL ESTATE SERVICES, NAMELY, CONDOMINIUM MANAGEMENT SERVICES; REAL ESTATE TRUSTEE SERVICES; REAL ESTATE VALUATION SERVICES; RESIDENTIAL REAL ESTATE AGENCY SERVICES (U.S. CLS. 100, 101 AND 102).

DAVID C. REIHNER, EXAMINING ATTORNEY

SN 85-447,992. ACCOUNT RECOVERY SPECIALISTS, INC., WICHITA, KS. FILED 10-14-2011.

ARSI

THE MARK CONSISTS OF STANDARD CHARACTERS WITHOUT CLAIM TO ANY PARTICULAR FONT, STYLE, SIZE, OR COLOR.

FOR DEBT RECOVERY AND COLLECTION AGENCIES (U.S. CLS. 100, 101 AND 102).

FIRST USE 6-24-1992; IN COMMERCE 6-24-1992.
 RONALD MCMORROW, EXAMINING ATTORNEY

CLASS 36—(Continued).

SN 85-447,993. METRO HEALTH SERVICES FEDERAL CREDIT UNION, DBA METRO CREDIT UNION, OMAHA, NE. FILED 10-14-2011.

PUTTING VALUE BACK IN BANKING

THE MARK CONSISTS OF STANDARD CHARACTERS WITHOUT CLAIM TO ANY PARTICULAR FONT, STYLE, SIZE, OR COLOR.

FOR CREDIT UNION SERVICES (U.S. CLS. 100, 101 AND 102).

FIRST USE 9-24-2011; IN COMMERCE 9-24-2011.

RONALD MCMORROW, EXAMINING ATTORNEY

SN 85-448,035. PREMIER MEMBERS FEDERAL CREDIT UNION, BOULDER, CO. FILED 10-14-2011.

Working together for better banking

THE MARK CONSISTS OF STANDARD CHARACTERS WITHOUT CLAIM TO ANY PARTICULAR FONT, STYLE, SIZE, OR COLOR.

FOR BANKING; BANKING AND FINANCING SERVICES; BANKING SERVICES (U.S. CLS. 100, 101 AND 102).

MICHAEL ENGEL, EXAMINING ATTORNEY

SN 85-448,063. CATTLEMEN'S DAYS, INC., GUNNISON, CO. FILED 10-14-2011.



THE MARK CONSISTS OF A COWBOY HAT PLACED OVER THE TOP OF A LOOPED RIBBON.

FOR CHARITABLE FUNDRAISING TO SUPPORT BREAST CANCER RESEARCH, DIAGNOSIS AND TREATMENT (U.S. CLS. 100, 101 AND 102).

FIRST USE 2-28-2006; IN COMMERCE 2-28-2006.

CURTIS FRENCH, EXAMINING ATTORNEY

CLASS 36—(Continued).

SN 85-448,193. THREE BRIDGES CAPITAL, LP, NEW YORK, NY. FILED 10-14-2011.

THREE BRIDGES CAPITAL

THE MARK CONSISTS OF STANDARD CHARACTERS WITHOUT CLAIM TO ANY PARTICULAR FONT, STYLE, SIZE, OR COLOR.

NO CLAIM IS MADE TO THE EXCLUSIVE RIGHT TO USE "CAPITAL", APART FROM THE MARK AS SHOWN.

FOR FINANCIAL SERVICES, NAMELY, ASSET MANAGEMENT SERVICES, INVESTMENT MANAGEMENT SERVICES AND INVESTMENT ADVISORY SERVICES RENDERED TO FUNDS AND TRADING ACCOUNTS FOR THE TRADING OF SECURITIES (U.S. CLS. 100, 101 AND 102).

ELIZABETH HUGHITT, EXAMINING ATTORNEY

SN 85-448,293. FIDOOSH, INC., MADISON, WI. FILED 10-15-2011.

TrustEgg

THE MARK CONSISTS OF STANDARD CHARACTERS WITHOUT CLAIM TO ANY PARTICULAR FONT, STYLE, SIZE, OR COLOR.

FOR TRUST SERVICES, NAMELY, INVESTMENT AND TRUST COMPANY SERVICES (U.S. CLS. 100, 101 AND 102).

RICHARD WHITE, EXAMINING ATTORNEY

SN 85-448,417. THE IBC NETWORK FOUNDATION, FRIENDSWOOD, TX. FILED S.R. 10-16-2011; AM. P.R. 2-3-2012.

Hunt for Hope

THE MARK CONSISTS OF STANDARD CHARACTERS WITHOUT CLAIM TO ANY PARTICULAR FONT, STYLE, SIZE, OR COLOR.

NO CLAIM IS MADE TO THE EXCLUSIVE RIGHT TO USE "HUNT", APART FROM THE MARK AS SHOWN.

FOR CHARITABLE FUNDRAISING SERVICES, NAMELY, ORGANIZING AND CONDUCTING SCAVENGER HUNTS TO RAISE MONEY FOR BREAST CANCER RESEARCH AND LOCAL COMMUNITY BREAST HEALTH AWARENESS PROGRAMS (U.S. CLS. 100, 101 AND 102).

FIRST USE 8-1-2011; IN COMMERCE 8-1-2011.

WILLIAM VERHOSEK, EXAMINING ATTORNEY

CLASS 36—(Continued).

SN 85-448,560. BOATHOUSE GROUP, INC., WALTHAM, MA. FILED 10-17-2011.

SPEEDBILLY

THE MARK CONSISTS OF STANDARD CHARACTERS WITHOUT CLAIM TO ANY PARTICULAR FONT, STYLE, SIZE, OR COLOR.

FOR PAYMENT PROCESSING SERVICES, NAMELY ELECTRONIC PROCESSING OF REFUNDABLE DEPOSITS MADE BY CONSUMERS TO RESERVE THE MOTOR VEHICLES OF OTHER VENDORS FOR FURTHER CONSIDERATION AND POSSIBLE PURCHASE; ELECTRONIC PROCESSING OF PARTIAL PAYMENTS FOR MOTOR VEHICLES (U.S. CLS. 100, 101 AND 102).

HOWARD SMIGA, EXAMINING ATTORNEY

CLASS 36—(Continued).

SN 85-448,765. RALEY, WATTS & O'NEILL, CALIFORNIA, MD. FILED 10-17-2011.

YOUR PROTECTION IS OUR MISSION

THE MARK CONSISTS OF STANDARD CHARACTERS WITHOUT CLAIM TO ANY PARTICULAR FONT, STYLE, SIZE, OR COLOR.

FOR INSURANCE SERVICES, NAMELY, CONSULTATION, BROKERAGE AND UNDERWRITING OF INSURANCE POLICIES FOR WORKER'S COMPENSATION, BUSINESS LIABILITY, PERSONAL UMBRELLA, DISABILITY INCOME, LONG-TERM CARE, AND LIFE INSURANCE; INSURANCE SERVICES, NAMELY, CONSULTATION, BROKERAGE AND UNDERWRITING OF INSURANCE POLICIES FOR AUTOMOBILES, MOTORCYCLES, BOATS, AND RECREATIONAL VEHICLES; INSURANCE SERVICES, NAMELY, CONSULTATION, BROKERAGE AND UNDERWRITING OF INSURANCE POLICIES FOR RENTERS, HOMEOWNERS, INSTITUTIONS, AND BUSINESSES; FINANCIAL SERVICES FOR EMPLOYEE BENEFIT PLANS, NAMELY, CONSULTATION, ADMINISTRATION AND INVESTMENT MANAGEMENT OF PENSION FUNDS, SIMPLE IRAS, PROFIT SHARING PLANS, AND 401(K) PLANS; FINANCIAL SERVICES FOR RETIREMENT, NAMELY, CONSULTATION, ADMINISTRATION AND INVESTMENT MANAGEMENT OF TRADITIONAL AND ROTH IRAS, FIXED AND VARIABLE ANNUITIES, AND CLIENT RETIREMENT PORTFOLIOS; FINANCIAL SERVICES FOR INVESTMENTS, NAMELY, MANAGEMENT AND DISTRIBUTION OF ANNUITIES, MUTUAL FUNDS, UNIT INVESTMENT TRUSTS, AND SECURITIES; FINANCIAL SERVICES FOR COLLEGE FUNDING, NAMELY, CONSULTATION AND ADMINISTERING SEC. 529 PLANS, AND PROVIDING CONSULTATION FOR COLLEGE COSTS AND FUNDING STRATEGIES USING LIFE INSURANCE; FINANCIAL SERVICES FOR BUSINESS CONTINUATION, NAMELY, CONSULTATION REGARDING INSURANCE BUY/SELL STRATEGIES, FUNDING OPTION ANALYSIS, AND KEY PERSON INSURANCE; FINANCIAL SERVICES FOR EXECUTIVE BENEFITS, NAMELY, CONSULTATION, MANAGEMENT AND DISTRIBUTION OF EXECUTIVE BONUS PLANS CONCERNING INSURANCE AND FINANCE, SUPPLEMENTAL EXECUTIVE RETIREMENT PLANS, AND SPLIT DOLLAR INSURANCE; FINANCIAL SERVICES FOR DEFERRED COMPENSATION, NAMELY, CONSULTATION, MANAGEMENT AND DISTRIBUTION OF SALARY CONTINUATION PLANS AND NON-QUALIFIED EXECUTIVE BENEFITS; FINANCIAL SERVICES FOR ESTATE PLANNING, NAMELY, LEGACY PLANNING AND CHARITABLE GIVING; FINANCIAL SERVICES, NAMELY, CONSULTATION FOR ASSET MANAGEMENT PROGRAMS AND COMPREHENSIVE FINANCIAL PLANS (U.S. CLS. 100, 101 AND 102).

DAVID I, EXAMINING ATTORNEY

SN 85-448,618. NATIONAL FAMILY MORTGAGE, LLC, NORWOOD, MA. FILED 10-17-2011.

ALWAYS INVEST IN FAMILY

THE MARK CONSISTS OF STANDARD CHARACTERS WITHOUT CLAIM TO ANY PARTICULAR FONT, STYLE, SIZE, OR COLOR.

FOR PROVIDING AN ONLINE FINANCIAL SERVICES WEBSITE FEATURING ELECTRONIC FUND TRANSFER SERVICES TO ENABLE INDIVIDUALS TO ENGAGE IN SECURED LENDING AND BORROWING TRANSACTIONS WITH OTHER INDIVIDUALS VIA A GLOBAL COMPUTER NETWORK; FINANCIAL AFFAIRS AND MONETARY AFFAIRS, NAMELY, PROVIDING FINANCIAL INFORMATION AND REAL ESTATE INFORMATION (U.S. CLS. 100, 101 AND 102).

FIRST USE 9-17-2011; IN COMMERCE 9-17-2011.

KATHERINE CHANG, EXAMINING ATTORNEY

SN 85-448,624. PROGRESSIVE CASUALTY INSURANCE COMPANY, MAYFIELD VILLAGE, OH. FILED 10-17-2011.

SMARTVIEW

THE MARK CONSISTS OF STANDARD CHARACTERS WITHOUT CLAIM TO ANY PARTICULAR FONT, STYLE, SIZE, OR COLOR.

FOR PROVIDING A SECURED ACCESS DATABASE VIA THE INTERNET THROUGH WHICH AUTHORIZED AGENTS CAN MONITOR CUSTOMERS' INSURANCE POLICIES, CUSTOMER SERVICE INQUIRIES, AND QUOTE ACTIVITY TO FACILITATE THE ORIGINATION, SERVICING, AND MANAGEMENT OF PROPERTY AND CASUALTY LINES OF INSURANCE (U.S. CLS. 100, 101 AND 102).

FIRST USE 11-21-2011; IN COMMERCE 11-21-2011.

ANDREA HACK, EXAMINING ATTORNEY

CLASS 36—(Continued).

SN 85-448,881. TEMPUS CONSULTING, INC., WASHINGTON, DC, DC. FILED 10-17-2011.



THE MARK CONSISTS OF A STYLIZED "T" DESIGN WITH FOUR COLUMNS IN THE MIDDLE, SURROUNDED BY A CIRCLE WITH A SINGLE LINE BORDER THAT IS BROKEN IN THREE SPOTS. SHADING IS NOT A CLAIMED FEATURE OF THE MARK.

FOR FOREIGN EXCHANGE INFORMATION SERVICES; FOREIGN EXCHANGE TRANSACTIONS (U.S. CLS. 100, 101 AND 102).

FIRST USE 3-0-1999; IN COMMERCE 3-0-1999.
BRIAN NEVILLE, EXAMINING ATTORNEY

SN 85-448,885. TEMPUS CONSULTING, INC., WASHINGTON, DC, DC. FILED 10-17-2011.

TEMPUS

THE MARK CONSISTS OF STANDARD CHARACTERS WITHOUT CLAIM TO ANY PARTICULAR FONT, STYLE, SIZE, OR COLOR.

FOR FOREIGN EXCHANGE INFORMATION SERVICES; FOREIGN EXCHANGE TRANSACTIONS (U.S. CLS. 100, 101 AND 102).

FIRST USE 3-0-1999; IN COMMERCE 3-0-1999.
BRIAN NEVILLE, EXAMINING ATTORNEY

SN 85-448,931. BANK MIDWEST, NATIONAL ASSOCIATION, KANSAS CITY, MO. FILED 10-17-2011.

WHERE COMMON SENSE LIVES

THE MARK CONSISTS OF STANDARD CHARACTERS WITHOUT CLAIM TO ANY PARTICULAR FONT, STYLE, SIZE, OR COLOR.

FOR BANKING SERVICES (U.S. CLS. 100, 101 AND 102).

FIRST USE 8-10-2011; IN COMMERCE 8-10-2011.
LINDA MICKLEBURGH, EXAMINING ATTORNEY

CLASS 36—(Continued).

SN 85-448,985. CORNERSTONE DEALER SERVICES, INC., HOUSTON, TX. FILED 10-17-2011.



THE COLOR(S) DARK BLUE, MEDIUM BLUE, BLUE, STEEL BLUE, SILVER, LIGHT GRAY, GRAY, BRIGHT WHITE, WHITE IS/ARE CLAIMED AS A FEATURE OF THE MARK.

THE MARK CONSISTS OF THE GLOBE WITH THE CONTINENTS IN SILVER AND LIGHT GRAY, THE WATER OF THE GLOBE FADES FROM TOP TO BOTTOM, DARK BLUE, MEDIUM BLUE, STEEL BLUE, BLUE, MEDIUM BLUE AND DARK BLUE, THERE ARE 7 MULTI-POINT STARS IN BRIGHT WHITE, THE STAR IS INSIDE A WHITE CIRCLE WITH ALL OF THE POINTS OF THE STAR OUTSIDE THE EDGE OF THE CIRCLE WITH RADIATING LINES FROM THE STARS IN WHITE, BELOW THE GLOBE THERE IS A GRAY SHADOW, TO THE RIGHT OF THE GLOBE THE WORD "MERIDIAN" WRITTEN IN STEEL BLUE WITH THE FONT BEING IN BASKERVILLE OLD FACE WITH THE "M" BEING CAPITALIZED.

FOR EXTENDED WARRANTY SERVICES, NAMELY, SERVICE CONTRACTS; WARRANTY CLAIMS ADMINISTRATION SERVICES, NAMELY, PROCESSING WARRANTY CLAIMS FOR VEHICLES (U.S. CLS. 100, 101 AND 102).

FIRST USE 10-11-2011; IN COMMERCE 10-11-2011.
SAIMA MAKHDOOM, EXAMINING ATTORNEY

SN 85-449,089. FIRST ACCEPTANCE CORPORATION, NASHVILLE, TN. FILED 10-17-2011.



THE MARK CONSISTS OF A DEPICTION OF THE FRONT OF A CAR, INCLUDING ROUND HEADLIGHTS, A CURVED BUMPER AND THE VISIBLE PORTION OF THE STEERING WHEEL CONFIGURED TO CREATE THE IMPRESSION OF SMILING FACIAL FEATURES.

FOR INSURANCE SERVICES, NAMELY INSURANCE BROKERAGE AND ADMINISTRATION IN THE FIELDS OF HOME, AUTOMOBILE, BOAT, RENTERS, HEALTH AND LIFE INSURANCE (U.S. CLS. 100, 101 AND 102).

JESSICA FATHY, EXAMINING ATTORNEY

CLASS 36—(Continued).

SN 85-449,105. BANK OF CAPE COD, HYANNIS, MA. FILED 10-17-2011.

BANK OF CAPE COD

THE MARK CONSISTS OF STANDARD CHARACTERS WITHOUT CLAIM TO ANY PARTICULAR FONT, STYLE, SIZE, OR COLOR.

OWNER OF U.S. REG. NO. 3,287,240.
NO CLAIM IS MADE TO THE EXCLUSIVE RIGHT TO USE "BANK", APART FROM THE MARK AS SHOWN.
SEC. 2(F).

FOR BANKING SERVICES (U.S. CLS. 100, 101 AND 102).

FIRST USE 8-15-2006; IN COMMERCE 8-15-2006.
FRED CARL, EXAMINING ATTORNEY

CLASS 36—(Continued).

SN 85-449,180. CICOLETTI, KATHRYN, SANTA MONICA, CA. FILED 10-17-2011.

MakinSense Babe

THE MARK CONSISTS OF STANDARD CHARACTERS WITHOUT CLAIM TO ANY PARTICULAR FONT, STYLE, SIZE, OR COLOR.

FOR PROVIDING A WEBSITE FEATURING INFORMATION, NEWS AND OPINIONS REGARDING MONEY MANAGEMENT, FINANCIAL NEWS, INVESTING, BUDGETING, EARNING AND SPENDING MONEY, MONEY-SAVING TIPS, AND LIFESTYLE AND ATTITUDE ISSUES RELATED TO PERSONAL FINANCE AND MONEY MANAGEMENT (U.S. CLS. 100, 101 AND 102).
DANNEAN HETZEL, EXAMINING ATTORNEY

SN 85-449,166. SCOTTRADE, INC., ST. LOUIS, MO. FILED 10-17-2011.

I'M WITH SCOTTRADE

THE MARK CONSISTS OF STANDARD CHARACTERS WITHOUT CLAIM TO ANY PARTICULAR FONT, STYLE, SIZE, OR COLOR.

OWNER OF U.S. REG. NOS. 2,140,963, 3,573,743 AND OTHERS.

FOR ON-LINE DISCOUNT SECURITIES BROKERAGE SERVICES (U.S. CLS. 100, 101 AND 102).

FIRST USE 10-10-2011; IN COMMERCE 10-10-2011.
KATHERINE CONNOLLY, EXAMINING ATTORNEY

SN 85-449,289. THE CALIFORNIA ENDOWMENT, LOS ANGELES, CA. FILED 10-17-2011.

FRESHWORKS

THE MARK CONSISTS OF STANDARD CHARACTERS WITHOUT CLAIM TO ANY PARTICULAR FONT, STYLE, SIZE, OR COLOR.

FOR OFFERING LOANS TO GROCERY STORES, MARKETS AND OTHER HEALTHY FOOD RETAILERS TO ENCOURAGE THE SALE AND CONSUMPTION OF FRESH PRODUCE AND HEALTHY FOOD ALTERNATIVES IN UNDERSERVED COMMUNITIES (U.S. CLS. 100, 101 AND 102).

FIRST USE 3-2-2011; IN COMMERCE 3-2-2011.
SANI KHOURI, EXAMINING ATTORNEY

SN 85-449,174. CICOLETTI, KATHRYN, SANTA MONICA, CA. FILED 10-17-2011.

**SSzzzsssizzling News &
Uncensored Views for the
Almost Affluent YOU**

THE MARK CONSISTS OF STANDARD CHARACTERS WITHOUT CLAIM TO ANY PARTICULAR FONT, STYLE, SIZE, OR COLOR.

FOR PROVIDING A WEBSITE FEATURING INFORMATION, NEWS AND OPINIONS REGARDING MONEY MANAGEMENT, FINANCIAL NEWS, INVESTING, BUDGETING, EARNING AND SPENDING MONEY, MONEY-SAVING TIPS, AND LIFESTYLE AND ATTITUDE ISSUES RELATED TO PERSONAL FINANCE AND MONEY MANAGEMENT (U.S. CLS. 100, 101 AND 102).
DANNEAN HETZEL, EXAMINING ATTORNEY

SN 85-449,340. PRIMAVERA FINANCIAL, INC., NEWPORT BEACH, CA. FILED 10-17-2011.

PRIMA PLUS

THE MARK CONSISTS OF STANDARD CHARACTERS WITHOUT CLAIM TO ANY PARTICULAR FONT, STYLE, SIZE, OR COLOR.

FOR FINANCIAL SERVICES, NAMELY, PROVISION OF LOANS AND FINANCING FOR HEALTHCARE TREATMENTS AND PROCEDURES (U.S. CLS. 100, 101 AND 102).

MATTHEW PAPPAS, EXAMINING ATTORNEY

CLASS 36—(Continued).

SN 85-449,450. UNION FEDERAL SAVINGS BANK, NORTH PROVIDENCE, RI. FILED 10-18-2011.

UNION FEDERAL

THE MARK CONSISTS OF STANDARD CHARACTERS WITHOUT CLAIM TO ANY PARTICULAR FONT, STYLE, SIZE, OR COLOR.

NO CLAIM IS MADE TO THE EXCLUSIVE RIGHT TO USE "FEDERAL", APART FROM THE MARK AS SHOWN.

FOR BANKING SERVICES; MORTGAGE BANKING SERVICES, LOAN FINANCING SERVICES (U.S. CLS. 100, 101 AND 102).

FIRST USE 11-12-2001; IN COMMERCE 11-12-2001.
WILLIAM VERHOSEK, EXAMINING ATTORNEY

SN 85-449,488. BUFFALO CHIP CAMPGROUND, LLC, STURGIS, SD. FILED 10-18-2011.

BIKER BELLES

THE MARK CONSISTS OF STANDARD CHARACTERS WITHOUT CLAIM TO ANY PARTICULAR FONT, STYLE, SIZE, OR COLOR.

FOR CHARITABLE FUNDRAISING (U.S. CLS. 100, 101 AND 102).

FIRST USE 4-14-2011; IN COMMERCE 4-14-2011.
BRIAN NEVILLE, EXAMINING ATTORNEY

SN 85-449,620. MAGELLAN ASSET MANAGEMENT LIMITED, SYDNEY NSW 2000, AUSTRALIA, FILED 10-18-2011.

MAML

THE MARK CONSISTS OF STANDARD CHARACTERS WITHOUT CLAIM TO ANY PARTICULAR FONT, STYLE, SIZE, OR COLOR.

FOR FINANCIAL SERVICES, NAMELY, INVESTMENT MANAGEMENT AND INVESTMENT ADVISORY SERVICES, ASSET MANAGEMENT, MUTUAL FUNDS AND INVESTMENT OF FUNDS FOR OTHERS (U.S. CLS. 100, 101 AND 102).

JORDAN BAKER, EXAMINING ATTORNEY

CLASS 36—(Continued).

SN 85-449,628. MAGELLAN ASSET MANAGEMENT LIMITED, SYDNEY NSW 2000, AUSTRALIA, FILED 10-18-2011.

MFG ASSET MANAGEMENT

THE MARK CONSISTS OF STANDARD CHARACTERS WITHOUT CLAIM TO ANY PARTICULAR FONT, STYLE, SIZE, OR COLOR.

NO CLAIM IS MADE TO THE EXCLUSIVE RIGHT TO USE "ASSET MANAGEMENT", APART FROM THE MARK AS SHOWN.

FOR FINANCIAL SERVICES, NAMELY, INVESTMENT MANAGEMENT AND INVESTMENT ADVISORY SERVICES, ASSET MANAGEMENT, MUTUAL FUNDS AND INVESTMENT OF FUNDS FOR OTHERS (U.S. CLS. 100, 101 AND 102).

JORDAN BAKER, EXAMINING ATTORNEY

SN 85-449,654. TGM ASSOCIATES L.P., NEW YORK, NY. FILED 10-18-2011.



THE MARK CONSISTS OF THE OUTLINE OF TWO ATTACHED HOUSES WITH CHIMNEYS ON AN INCLINE.

FOR ACQUISITION OF MULTI-FAMILY HOUSING ON BEHALF OF INVESTOR CLIENTS; REAL ESTATE SERVICES, NAMELY, PROVISION OF COMMERCIAL AND RENTAL PROPERTY MANAGEMENT SERVICES TO INVESTOR CLIENTS (U.S. CLS. 100, 101 AND 102).

FIRST USE 6-1-2011; IN COMMERCE 6-1-2011.
HANNO RITTNER, EXAMINING ATTORNEY

CLASS 36—(Continued).

SN 85-449,814. MISSION HEALTH SYSTEM, INC., ASHEVILLE, NC. FILED 10-18-2011.

MISSION FOUNDATION

THE MARK CONSISTS OF STANDARD CHARACTERS WITHOUT CLAIM TO ANY PARTICULAR FONT, STYLE, SIZE, OR COLOR.

OWNER OF U.S. REG. NOS. 2,917,751, 3,763,900 AND OTHERS.

NO CLAIM IS MADE TO THE EXCLUSIVE RIGHT TO USE "FOUNDATION", APART FROM THE MARK AS SHOWN.

FOR CHARITABLE FUND RAISING SERVICES, NAMELY, FOR THE SUPPORT OF MEDICAL CARE FOR HOSPITAL PATIENTS, HOSPITAL FACILITIES AND EQUIPMENT, AND HEALTH-RELATED EDUCATIONAL PROGRAMS; CHARITABLE FOUNDATION SERVICES, NAMELY, PROVIDING SUPPLEMENTAL FUNDING, CAPITAL IMPROVEMENT FUNDING, AND/OR FINANCIAL ASSISTANCE FOR MEDICAL CARE FOR HOSPITAL PATIENTS, HOSPITAL FACILITIES AND EQUIPMENT, AND HEALTH-RELATED EDUCATIONAL PROGRAMS (U.S. CLS. 100, 101 AND 102).

DOMINIC FATHY, EXAMINING ATTORNEY

SN 85-449,858. FCOA, LLC, CALEDONIA, MI. FILED 10-18-2011.

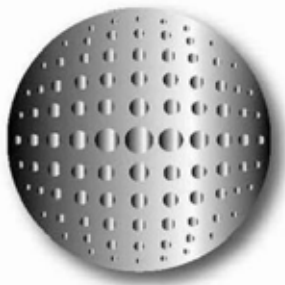

THE MARK CONSISTS OF A SPHERE DESIGN CONTAINING SMALLER CIRCLES THAT GET LARGER AS THEY PROGRESS TOWARD THE MIDDLE OF THE SPHERE; THERE IS ALSO A SHADING EFFECT TO THE RIGHT-SIDE OF THE SPHERE DESIGN.

FOR PROPERTY AND CASUALTY INSURANCE UNDERWRITING SERVICES; INSURANCE CLAIMS PROCESSING, INSURANCE CLAIMS ADMINISTRATION, AND INSURANCE AGENCIES; PROVIDING INFORMATION IN INSURANCE MATTERS (U.S. CLS. 100, 101 AND 102).

BENJAMIN OKEKE, EXAMINING ATTORNEY

CLASS 36—(Continued).

SN 85-449,955. POLANSKY, JENNIFER J., GOODYEAR, AZ. FILED 10-18-2011.

Get More Ooh La-La, For Your Mu-La-La

THE MARK CONSISTS OF STANDARD CHARACTERS WITHOUT CLAIM TO ANY PARTICULAR FONT, STYLE, SIZE, OR COLOR.

FOR COMMERCIAL AND RESIDENTIAL REAL ESTATE AGENCY SERVICES (U.S. CLS. 100, 101 AND 102). FIRST USE 6-1-2009; IN COMMERCE 8-1-2009.

CARRIE GENOVESE, EXAMINING ATTORNEY

SN 85-450,365. HANSON, ELAINE, TOPANGA, CA. FILED 10-18-2011.

Discover Topanga

THE MARK CONSISTS OF STANDARD CHARACTERS WITHOUT CLAIM TO ANY PARTICULAR FONT, STYLE, SIZE, OR COLOR.

NO CLAIM IS MADE TO THE EXCLUSIVE RIGHT TO USE "TOPANGA", APART FROM THE MARK AS SHOWN.

FOR PROVIDING AN INTERNET WEBSITE PORTAL OFFERING INFORMATION IN THE FIELDS OF REAL ESTATE CONCERNING THE PURCHASE AND SALE OF NEW AND RESALE HOMES AND CONDOS; PROVIDING INFORMATION IN THE FIELD OF REAL ESTATE VIA THE INTERNET; REAL ESTATE LISTING; RESIDENTIAL REAL ESTATE AGENCY SERVICES (U.S. CLS. 100, 101 AND 102).

FIRST USE 10-2-2007; IN COMMERCE 10-2-2007.

NAPOLEON SHARMA, EXAMINING ATTORNEY

SN 85-450,635. HAY, SUZANNE, LAWTON, OK. FILED 10-19-2011.



THE MARK CONSISTS OF A RIBBON LADY RIDING A MOTORCYCLE WITH A SEMI-CIRCLE OF STARS BORDERED BY A STRIPE.

FOR CHARITABLE FUNDRAISING SERVICES BY MEANS OF MOTORCYCLE RIDING EVENTS (U.S. CLS. 100, 101 AND 102).

FIRST USE 10-1-2009; IN COMMERCE 10-1-2009.

B. PARADEWELAI, EXAMINING ATTORNEY

CLASS 36—(Continued).

SN 85-452,762. ZULUTRADE INC., NEW YORK, NY. FILED 10-21-2011.

ZULUTRADE

THE MARK CONSISTS OF STANDARD CHARACTERS WITHOUT CLAIM TO ANY PARTICULAR FONT, STYLE, SIZE, OR COLOR.

FOR ONLINE FOREIGN EXCHANGE AUTOTRADING SERVICES (U.S. CLS. 100, 101 AND 102).
FIRST USE 2-27-2007; IN COMMERCE 2-27-2007.
TASNEEM HUSSAIN, EXAMINING ATTORNEY

SN 85-453,365. EPPS, XAVIER N, WOODBRIDGE, VA. FILED 10-21-2011.

 *X-scape to Financial Freedom*

NO CLAIM IS MADE TO THE EXCLUSIVE RIGHT TO USE "FINANCIAL", APART FROM THE MARK AS SHOWN.

THE MARK CONSISTS OF THE STYLIZED WORDING "X-SCAPE TO FINANCIAL FREEDOM".

FOR FINANCIAL PLANNING FEATURING PERSONAL DEBT ANALYSIS, BUDGET PLANNING AND SMALL BUSINESS CASH FLOW MANAGEMENT (U.S. CLS. 100, 101 AND 102).

IRA J. GOODSaid, EXAMINING ATTORNEY

SN 85-453,413. SYMETRA LIFE INSURANCE COMPANY, BELLEVUE, WA. FILED 10-21-2011.



THE COLOR(S) BLUE IS/ARE CLAIMED AS A FEATURE OF THE MARK.

THE MARK CONSISTS OF A SIDE VIEW DESIGN OF A FANCIFUL BIRD IN SILHOUETTE, IN THE COLOR BLUE.

FOR INSURANCE AND INVESTMENT SERVICES, NAMELY, INSURANCE AGENCY AND BROKERAGE AND UNDERWRITING OF LIFE INSURANCE; INVESTMENT BROKERAGE, DISTRIBUTION, AND UNDERWRITING OF ANNUITIES; INSURANCE AGENCY AND BROKERAGE, DISTRIBUTION, AND UNDERWRITING OF STOP-LOSS INSURANCE; INSURANCE AGENCY AND BROKERAGE, DISTRIBUTION AND UNDERWRITING OF REINSURANCE; BROKERAGE, DISTRIBUTION, AND MANAGEMENT OF INVESTMENTS AND MUTUAL FUNDS; MONEY LENDING (U.S. CLS. 100, 101 AND 102).

KAREN K. BUSH, EXAMINING ATTORNEY

CLASS 36—(Continued).

SN 85-456,207. FMR LLC, BOSTON, MA. FILED 10-26-2011.

FIDELITY PRIVATE WEALTH MANAGEMENT

THE MARK CONSISTS OF STANDARD CHARACTERS WITHOUT CLAIM TO ANY PARTICULAR FONT, STYLE, SIZE, OR COLOR.

OWNER OF U.S. REG. NOS. 2,846,561, 3,693,763 AND OTHERS.

NO CLAIM IS MADE TO THE EXCLUSIVE RIGHT TO USE "PRIVATE WEALTH MANAGEMENT", APART FROM THE MARK AS SHOWN.

FOR FINANCIAL SERVICES, NAMELY, FINANCIAL PLANNING, WEALTH PLANNING, FINANCIAL ASSET MANAGEMENT, FINANCIAL ASSET PROTECTION, FINANCIAL TRUST ADMINISTRATION AND ESTATE PLANNING SERVICES (U.S. CLS. 100, 101 AND 102).

MARIA-VICTORIA SUAREZ, EXAMINING ATTORNEY

SN 85-461,993. KENDALL DATA LLC, WILMINGTON, DE. FILED 11-1-2011.

 **Late Fee Protection**

NO CLAIM IS MADE TO THE EXCLUSIVE RIGHT TO USE "LATE FEE PROTECTION", APART FROM THE MARK AS SHOWN.

THE MARK CONSISTS OF A PORTION OF A STYLIZED SHIELD TOGETHER WITH THE WORDS "LATE FEE PROTECTION".

FOR COMPUTER DATA PROCESSING IN THE FIELD OF FINANCIAL TRANSACTIONS (U.S. CLS. 100, 101 AND 102).

DAVID MURRAY, EXAMINING ATTORNEY

SN 85-464,700. GREAT-WEST LIFE & ANNUITY INSURANCE COMPANY, GREENWOOD VILLAGE, CO. FILED 11-4-2011.

GREAT-WEST SMART TRACK

THE MARK CONSISTS OF STANDARD CHARACTERS WITHOUT CLAIM TO ANY PARTICULAR FONT, STYLE, SIZE, OR COLOR.

OWNER OF U.S. REG. NOS. 1,683,217, 3,398,240 AND OTHERS.

FOR FINANCIAL SERVICES, NAMELY, INVESTMENT MANAGEMENT AND DISTRIBUTION OF ANNUITIES (U.S. CLS. 100, 101 AND 102).

MICHELE SWAIN, EXAMINING ATTORNEY

CLASS 36—(Continued).

SN 85-468,292. COMMUNITY CHOICE FAMILY INSURANCE AGENCY, LLC, DUBLIN, OH. FILED 11-9-2011.



NO CLAIM IS MADE TO THE EXCLUSIVE RIGHT TO USE "FAMILY INSURANCE", APART FROM THE MARK AS SHOWN.

THE MARK CONSISTS OF TWO INTERSECTING ARCHES ABOVE THE WORDS "COMMUNITY CHOICE" IN LARGER FONT OVER THE WORDS "FAMILY INSURANCE", WITH THE ARCHES EXTENDING FROM THE LETTER "U" IN "COMMUNITY" TO THE SECOND "C" IN "CHOICE".

FOR INSURANCE AGENCY SERVICES (U.S. CLS. 100, 101 AND 102).

FIRST USE 11-8-2011; IN COMMERCE 11-8-2011.
VERNA BETH RIRIE, EXAMINING ATTORNEY

SN 85-476,993. GREEN DOT CORPORATION, MONROVIA, CA. FILED 11-18-2011.

**IT'S YOUR MONEY. TAKE
CONTROL TODAY.**

THE MARK CONSISTS OF STANDARD CHARACTERS WITHOUT CLAIM TO ANY PARTICULAR FONT, STYLE, SIZE, OR COLOR.

FOR BANKING SERVICES; DEBIT CARD SERVICES (U.S. CLS. 100, 101 AND 102).

MATTHEW EINSTEIN, EXAMINING ATTORNEY

SN 85-478,252. MASTERCARD INTERNATIONAL INCORPORATED, PURCHASE, NY. FILED 11-21-2011.

**TAP & GO THE NEWEST WAY TO
PAY**

THE MARK CONSISTS OF STANDARD CHARACTERS WITHOUT CLAIM TO ANY PARTICULAR FONT, STYLE, SIZE, OR COLOR.

OWNER OF U.S. REG. NOS. 2,849,568, 3,335,821 AND OTHERS.

FOR FINANCIAL SERVICES, NAMELY, CREDIT AND DEBIT CARD SERVICES; FINANCIAL SERVICES, NAMELY, PROVISION OF CONTACTLESS MOBILE PAYMENTS BY MEANS OF RADIO FREQUENCY IDENTIFICATION DEVICES, NAMELY, TRANSPONDERS (U.S. CLS. 100, 101 AND 102).

DAVID MURRAY, EXAMINING ATTORNEY

CLASS 36—(Continued).

SN 85-479,968. EVERBANK, JACKSONVILLE, FL. FILED 11-23-2011.



OWNER OF U.S. REG. NOS. 2,568,122, 3,845,024 AND OTHERS.

THE MARK CONSISTS OF WORDS "EVERBANK INFINITY" WITH THE DESIGN ELEMENT IN THE "Y" IN THE WORD "INFINITY" DISPLAYING THE SYMBOL FOR INFINITY.

FOR BANKING AND FINANCING SERVICES; BANKING CONSULTATION; ON-LINE BANKING SERVICES (U.S. CLS. 100, 101 AND 102).

TINA MAI, EXAMINING ATTORNEY

SN 85-487,321. AMANRESORTS LIMITED, CENTRAL, HONG KONG, FILED 12-5-2011.

AMANZOE

THE MARK CONSISTS OF STANDARD CHARACTERS WITHOUT CLAIM TO ANY PARTICULAR FONT, STYLE, SIZE, OR COLOR.

OWNER OF U.S. REG. NOS. 2,828,188, 3,133,393 AND 3,341,763.

THE ENGLISH TRANSLATION OF "AMAN" IN THE MARK IS "PEACEFUL".

FOR REAL ESTATE SERVICES, NAMELY, ARRANGING OF LEASES AND RENTAL AGREEMENTS FOR REAL ESTATE, ASSESSMENT AND MANAGEMENT OF REAL ESTATE, LEASING OF REAL ESTATE, REAL ESTATE APPRAISAL, RENTAL PROPERTY MANAGEMENT; PROVISION OF HOUSING ACCOMMODATION, NAMELY, REAL ESTATE ACQUISITION SERVICES; PROVISION OF INFORMATION RELATING TO REAL ESTATE PROPERTY; REAL ESTATE PROPERTY LEASING; REAL ESTATE PROPERTY MANAGEMENT; REAL ESTATE PROPERTY CONSULTANCY SERVICES; REAL ESTATE AGENCY SERVICES; REAL ESTATE PROPERTY BROKERAGE SERVICES; REAL ESTATE MANAGEMENT SERVICES (U.S. CLS. 100, 101 AND 102).

HENRY S. ZAK, EXAMINING ATTORNEY

SN 85-490,697. GREEN DOT CORPORATION, MONROVIA, CA. FILED 12-8-2011.

PROFESSOR DOG

THE MARK CONSISTS OF STANDARD CHARACTERS WITHOUT CLAIM TO ANY PARTICULAR FONT, STYLE, SIZE, OR COLOR.

FOR DEBIT CARD SERVICES; CASH CARD SERVICES (U.S. CLS. 100, 101 AND 102).

MATTHEW EINSTEIN, EXAMINING ATTORNEY

CLASS 36—(Continued).

SN 85-519,400. MASTERCARD INTERNATIONAL INCORPORATED, PURCHASE, NY. FILED 1-18-2012.

MASTERCARD TAP & RIDE

THE MARK CONSISTS OF STANDARD CHARACTERS WITHOUT CLAIM TO ANY PARTICULAR FONT, STYLE, SIZE, OR COLOR.

OWNER OF U.S. REG. NOS. 1,186,117, 1,814,279 AND OTHERS.

FOR BANKING SERVICES; FINANCIAL SERVICES; NAMELY, CREDIT AND DEBIT CARD SERVICES, FINANCIAL TRANSACTION AUTHORIZATION AND SETTLEMENT SERVICES; FINANCIAL SERVICES, NAMELY, PROVISION OF DEBIT CARD SERVICES AND CREDIT CARD SERVICES BY MEANS OF RADIO FREQUENCY IDENTIFICATION DEVICES, NAMELY, TRANSPONDERS (U.S. CLS. 100, 101 AND 102).
DAVID MURRAY, EXAMINING ATTORNEY

CLASS 37—(Continued).

SN 76-709,078. PIONEER DRILLING COMPANY, SAN ANTONIO, TX. FILED 9-15-2011.

PIONEER

THE MARK CONSISTS OF STANDARD CHARACTERS WITHOUT CLAIM TO ANY PARTICULAR FONT, STYLE, SIZE, OR COLOR.

OWNER OF U.S. REG. NOS. 3,217,824, 3,778,719 AND OTHERS.

FOR OIL AND GAS DRILLING; OIL AND GAS WELL SERVICING, NAMELY, OIL AND GAS WELL MAINTENANCE AND REPAIR; OIL AND GAS WELL COMPLETION AND WORK OVER SERVICES, NAMELY, PREPARING WELLS FOR PRODUCTION AND CLEANING, REPAIRING AND MAINTAINING RE-ENTERED WELLS; PLUGGING AND ABANDONMENT OF OIL AND GAS WELLS; RENTAL OF OIL AND GAS WELL EQUIPMENT AND FISHING TOOLS; FLUID DISPOSAL, NAMELY, DISPOSAL OF BRINE AND OTHER DRILLING AND PRODUCTION FLUIDS USED IN OIL AND GAS DRILLING; WIRELINING FOR OIL AND GAS WELLS; OIL AND GAS FRACTURING, NAMELY, WELL IMPROVEMENT SERVICES, NAMELY, HYDRAULIC FRACTURING OF SUBSURFACE GEOLOGIC FORMATIONS TO ENHANCE WELL PRODUCTION (U.S. CLS. 100, 103 AND 106).

FIRST USE 2-27-1989; IN COMMERCE 2-27-1989.
TASNEEM HUSSAIN, EXAMINING ATTORNEY

CLASS 37—CONSTRUCTION AND REPAIR

SN 76-706,881. CALHOUN PROPERTIES, SEATTLE, WA. FILED 3-17-2011.

aPodments

THE MARK CONSISTS OF STANDARD CHARACTERS WITHOUT CLAIM TO ANY PARTICULAR FONT, STYLE, SIZE, OR COLOR.

OWNER OF U.S. REG. NO. 3,808,828.

FOR DEVELOPMENT AND CONSTRUCTION OF MICRO-UNIT RESIDENTIAL APARTMENTS AND SMALL RESIDENTIAL APARTMENTS (U.S. CLS. 100, 103 AND 106).

TINA BROWN, EXAMINING ATTORNEY

SN 85-062,151. CARNEY PLUMBING, HEATING & COOLING, INC., LINE LEXINGTON, PA. FILED 6-14-2010.

**CARNEY PLUMBING HEATING
COOLING**

THE MARK CONSISTS OF STANDARD CHARACTERS WITHOUT CLAIM TO ANY PARTICULAR FONT, STYLE, SIZE, OR COLOR.

NO CLAIM IS MADE TO THE EXCLUSIVE RIGHT TO USE "PLUMBING HEATING COOLING", APART FROM THE MARK AS SHOWN.

SEC. 2(F).

FOR PLUMBING SERVICES; INSTALLATION, REPAIR AND MAINTENANCE OF PLUMBING, HEATING, VENTILATION AND AIR CONDITIONING EQUIPMENT AND SYSTEMS (U.S. CLS. 100, 103 AND 106).

FIRST USE 10-1-2002; IN COMMERCE 10-20-2006.
ANGELA M. MICHELI, EXAMINING ATTORNEY

CLASS 37—(Continued).

SN 85-074,017. WHR HOLDINGS, LLC, HOLLYWOOD, FL. FILED 6-29-2010.

ACME KOHLMAN CHUTE SYSTEMS

THE MARK CONSISTS OF STANDARD CHARACTERS WITHOUT CLAIM TO ANY PARTICULAR FONT, STYLE, SIZE, OR COLOR.

OWNER OF U.S. REG. NO. 3,827,022.

NO CLAIM IS MADE TO THE EXCLUSIVE RIGHT TO USE "CHUTE SYSTEMS", APART FROM THE MARK AS SHOWN.

FOR INSTALLATION, MAINTENANCE AND REPAIR OF TRASH CHUTES, TRASH CHUTE DOORS, TRASH COMPACTORS, SORTING MACHINES FOR SORTING RECYCLABLE MATERIALS, LAUNDRY CHUTES AND LAUNDRY CHUTE DOORS (U.S. CLS. 100, 103 AND 106).

CHRISTINE COOPER, EXAMINING ATTORNEY

SN 85-107,019. SYROS, LLC, VIRGINIA BEACH, VA. FILED 8-13-2010.

THE DRAGAS GROUP

THE MARK CONSISTS OF STANDARD CHARACTERS WITHOUT CLAIM TO ANY PARTICULAR FONT, STYLE, SIZE, OR COLOR.

NO CLAIM IS MADE TO THE EXCLUSIVE RIGHT TO USE "GROUP", APART FROM THE MARK AS SHOWN.

FOR BUILDING CONSTRUCTION SERVICES; CONSTRUCTION OF COMMERCIAL, EDUCATIONAL, HISTORIC, INSTITUTIONAL, INDUSTRIAL, RETAIL AND RESIDENTIAL BUILDINGS, HOMES AND COMMERCIAL, INDUSTRIAL AND INSTITUTIONAL FACILITIES, BUILDING COMPLEXES; CUSTOM CONSTRUCTION OF COMMERCIAL, INDUSTRIAL, RETAIL, EDUCATIONAL, HISTORIC AND RESIDENTIAL BUILDINGS, HOMES AND COMMERCIAL, INDUSTRIAL AND INSTITUTIONAL FACILITIES, AND BUILDING COMPLEXES; BUILDING CONSTRUCTION; GENERAL BUILDING CONTRACTOR SERVICES; CONSTRUCTION MANAGEMENT; CONSTRUCTION SUPERVISION; RENOVATION AND REPAIR SERVICES FOR BUILDINGS, HOMES AND COMMERCIAL, INDUSTRIAL AND INSTITUTIONAL FACILITIES; REAL ESTATE DEVELOPMENT; LAND DEVELOPMENT SERVICES, NAMELY, PLANNING AND REAL ESTATE DEVELOPMENT OF RESIDENTIAL AND COMMERCIAL COMMUNITIES; BUILDING INSPECTION, NAMELY, INSPECTING STRUCTURAL, MECHANICAL, ELECTRICAL SYSTEMS OF BUILDINGS AND COMMERCIAL, INDUSTRIAL AND INSTITUTIONAL FACILITIES; CONSULTING SERVICES IN THE DESIGN AND DEVELOPMENT OF PREVENTIVE MAINTENANCE PROGRAMS FOR THE STRUCTURAL, MECHANICAL, ELECTRICAL SYSTEMS OF BUILDINGS AND COMMERCIAL, INDUSTRIAL AND INSTITUTIONAL FACILITIES; OFF SITE BUILDING CONSTRUCTION PROJECT MANAGEMENT (U.S. CLS. 100, 103 AND 106).

RENEE SERVANCE, EXAMINING ATTORNEY

CLASS 37—(Continued).

SN 85-128,166. CJ 4DPLEX CO., LTD., SEOUL, REPUBLIC OF KOREA, FILED 9-13-2010.

4DPLEX

THE MARK CONSISTS OF STANDARD CHARACTERS WITHOUT CLAIM TO ANY PARTICULAR FONT, STYLE, SIZE, OR COLOR.

PRIORITY CLAIMED UNDER SEC. 44(D) ON REPUBLIC OF KOREA APPLICATION NO. 41-2010-2347, FILED 9-10-2010, REG. NO. 0223562, DATED 12-23-2011, EXPIRES 12-23-2021.

FOR CONSTRUCTION OF BUILDINGS; REPAIR OF BUILDINGS; BUILDING OF THEATRES; INSTALLATION OF THEATRE PLANTS; BUILDING OF THEATRES FEATURING MOVIES AUDIENCE EFFECTS SUCH AS WIND, SCENT, WATER SPRAY, MOTION, VIBRATION, SMOKE, BUBBLE, LASER OR FLASH; INSTALLATION OF THEATRE PLANTS FOR MOVIES AUDIENCE EFFECTS SUCH AS WIND, SCENT, WATER SPRAY, MOTION, VIBRATION, SMOKE, BUBBLE, LASER OR FLASH; BUILDING CONSTRUCTION SUPERVISION; DRILLING OF WELLS; CLEANING OF BUILDING EXTERIOR SURFACES; HEATING EQUIPMENT INSTALLATION AND REPAIR; INSTALLATION, MAINTENANCE AND REPAIR OF MACHINERY FOR MOVIES AUDIENCE EFFECTS IN CINEMA; FILM PROJECTOR REPAIR; SAFE MAINTENANCE AND REPAIR; FURNITURE RESTORATION; REPAIR OF MUSICAL INSTRUMENTS (U.S. CLS. 100, 103 AND 106).

RON FAIRBANKS, EXAMINING ATTORNEY

SN 85-275,267. RENU SYSTEMS, INC., ADDISON, IL. FILED 3-24-2011.

RAPID REVENUE RESTORATION

THE MARK CONSISTS OF STANDARD CHARACTERS WITHOUT CLAIM TO ANY PARTICULAR FONT, STYLE, SIZE, OR COLOR.

NO CLAIM IS MADE TO THE EXCLUSIVE RIGHT TO USE "RESTORATION", APART FROM THE MARK AS SHOWN.

FOR COMMERCIAL CLEANING SERVICES, NAMELY, CLEANING OF CARPET, DRAPES, UPHOLSTERY, PACKAGED TERMINAL AIR CONDITIONING UNITS, TILE, GROUT, STONE (U.S. CLS. 100, 103 AND 106).

FIRST USE 3-22-2011; IN COMMERCE 3-22-2011.
JOHN KELLY, EXAMINING ATTORNEY

CLASS 37—(Continued).

SN 85-282,451. SUFFOLK CONSTRUCTION COMPANY, INC., BOSTON, MA. FILED 3-31-2011.



NO CLAIM IS MADE TO THE EXCLUSIVE RIGHT TO USE "BUILD", APART FROM THE MARK AS SHOWN. THE COLOR(S) BLUE, RED, GRAY AND WHITE IS/ARE CLAIMED AS A FEATURE OF THE MARK.

THE MARK CONSISTS OF A RECTANGLE WITH THE LEFT SIDE IN BLUE AND THE RIGHT SIDE IN RED. THE WHITE WORD "SUFFOLK" IS CENTERED INSIDE THE RECTANGLE. THE GRAY WORDING "BUILD SMART" APPEARS ABOVE THE RECTANGLE. THE REMAINDER OF THE WHITE IN THE DRAWING REPRESENTS BACKGROUND AREAS ONLY AND IS NOT PART OF THE MARK.

SEC. 2(F) AS TO "SUFFOLK".

FOR CONSTRUCTION SERVICES, NAMELY, PLANNING, LAYING OUT AND CUSTOM CONSTRUCTION OF RESIDENTIAL AND COMMERCIAL BUILDINGS; BUILDING CONSTRUCTION, REMODELING AND REPAIR; CONSTRUCTION MANAGEMENT (SUPERVISION); CONSTRUCTION PLANNING; CONSTRUCTION PROJECT MANAGEMENT SERVICES; CONSULTING IN THE FIELD OF BUILDING CONSTRUCTION (U.S. CLS. 100, 103 AND 106).

MAUREEN DALL, EXAMINING ATTORNEY

SN 85-293,296. PN II, INC., BLOOMFIELD HILLS, MI. FILED 4-12-2011.

LIFE TESTED

THE MARK CONSISTS OF STANDARD CHARACTERS WITHOUT CLAIM TO ANY PARTICULAR FONT, STYLE, SIZE, OR COLOR.

FOR PLANNING AND CONSTRUCTION SERVICES, NAMELY, PLANNING, LAYING OUT AND CONSTRUCTION OF RESIDENTIAL COMMUNITIES (U.S. CLS. 100, 103 AND 106).

FIRST USE 3-1-2011; IN COMMERCE 3-1-2011.

JORDAN BAKER, EXAMINING ATTORNEY

CLASS 37—(Continued).

SN 85-299,868. MABRU POWER SYSTEMS, INC., FORT LAUDERDALE, FL. FILED 4-20-2011.

MABRU

THE MARK CONSISTS OF STANDARD CHARACTERS WITHOUT CLAIM TO ANY PARTICULAR FONT, STYLE, SIZE, OR COLOR.

THE WORDING "MABRU" HAS NO MEANING IN A FOREIGN LANGUAGE.

FOR INSTALLATION AND MAINTENANCE OF MARINE AIR CONDITIONERS, MARINE GENERATORS, AND RELATED MARINE ELECTRONICS, INCLUDING UNDERWATER LIGHTS AND WATER MAKERS (U.S. CLS. 100, 103 AND 106).

FIRST USE 5-1-1995; IN COMMERCE 5-1-1995.

BILL DAWE, EXAMINING ATTORNEY

SN 85-420,673. MR AUDIO AND VIDEO, INC., NEWPORT, NC. FILED 9-12-2011.

MR Audio & Video

THE MARK CONSISTS OF STANDARD CHARACTERS WITHOUT CLAIM TO ANY PARTICULAR FONT, STYLE, SIZE, OR COLOR.

NO CLAIM IS MADE TO THE EXCLUSIVE RIGHT TO USE "AUDIO & VIDEO", APART FROM THE MARK AS SHOWN.

FOR INSTALLATION AND SERVICING OF AUDIO AND VIDEO EQUIPMENT (U.S. CLS. 100, 103 AND 106).

FIRST USE 4-1-2010; IN COMMERCE 4-1-2010.

KRISTINA MORRIS, EXAMINING ATTORNEY

SN 85-430,287. PH4 CORPORATION, BLOOMFIELD HILLS, MI. FILED 9-23-2011.

INSPIRED DESIGNS BY DEL WEBB

THE MARK CONSISTS OF STANDARD CHARACTERS WITHOUT CLAIM TO ANY PARTICULAR FONT, STYLE, SIZE, OR COLOR.

OWNER OF U.S. REG. NOS. 2,345,498, 2,877,276 AND OTHERS.

NO CLAIM IS MADE TO THE EXCLUSIVE RIGHT TO USE "DESIGNS", APART FROM THE MARK AS SHOWN.

THE NAME "DEL WEBB" DOES NOT IDENTIFY A LIVING INDIVIDUAL.

FOR PLANNING AND CONSTRUCTION SERVICES, NAMELY PLANNING, LAYING OUT AND CONSTRUCTION OF RESIDENTIAL BUILDINGS AND COMMUNITIES (U.S. CLS. 100, 103 AND 106).

FIRST USE 10-15-2011; IN COMMERCE 10-15-2011.

MARILYN IZZI, EXAMINING ATTORNEY

CLASS 37—(Continued).

SN 85-433,530. AEROTURBINE, INC., MIAMI, FL. FILED 9-27-2011.

 The logo for AEROTURBINE features the word "AEROTURBINE" in a bold, sans-serif font. The letters "A", "E", and "O" are stylized with a thick, curved underline that loops around the letters, creating a sense of motion or a turbine-like structure.

OWNER OF U.S. REG. NOS. 2,260,554 AND 3,138,938.
 THE MARK CONSISTS OF "AEROTURBINE" WITH
 SWIRL DESIGN OVER "AERO".
 FOR MAINTENANCE, REPAIR AND OVERHAUL OF
 AIRCRAFT AND AIRCRAFT ENGINES AND PARTS
 THEREOF (U.S. CLS. 100, 103 AND 106).
 DAVID ELTON, EXAMINING ATTORNEY

CLASS 37—(Continued).

SN 85-445,149. IPR PLUMBER, LLC, HOUSTON, TX. FILED 10-12-2011.

HOME GUARD

THE MARK CONSISTS OF STANDARD CHARACTERS
 WITHOUT CLAIM TO ANY PARTICULAR FONT, STYLE,
 SIZE, OR COLOR.

FOR PREVENTATIVE MAINTENANCE SERVICES IN
 THE HVAC AND PLUMBING INDUSTRY (U.S. CLS. 100,
 103 AND 106).

MATTHEW KLINE, EXAMINING ATTORNEY

SN 85-435,423. ROOF ASSET MANAGEMENT USA,
 STRONGSVILLE, OH. FILED 9-29-2011.

RoofRAM

THE MARK CONSISTS OF STANDARD CHARACTERS
 WITHOUT CLAIM TO ANY PARTICULAR FONT, STYLE,
 SIZE, OR COLOR.

FOR ROOFING CONSULTATION (U.S. CLS. 100, 103
 AND 106).

FIRST USE 9-1-2009; IN COMMERCE 10-7-2009.
 TASHIA BUNCH, EXAMINING ATTORNEY

SN 85-446,105. ALLIED CLEANING SERVICES, LLC, POSEN,
 IL. FILED 10-12-2011.

Allied Services

THE MARK CONSISTS OF STANDARD CHARACTERS
 WITHOUT CLAIM TO ANY PARTICULAR FONT, STYLE,
 SIZE, OR COLOR.

NO CLAIM IS MADE TO THE EXCLUSIVE RIGHT TO
 USE "SERVICES", APART FROM THE MARK AS SHOWN.
 FOR PEST CONTROL AND EXTERMINATION OTHER
 THAN FOR AGRICULTURAL PURPOSES (U.S. CLS. 100,
 103 AND 106).

FIRST USE 5-1-2009; IN COMMERCE 5-1-2009.
 HANNO RITTNER, EXAMINING ATTORNEY

SN 85-441,631. CART SHIELD USA, LLC, POMPANO
 BEACH, FL. FILED 10-7-2011.

Max Green Protection

THE MARK CONSISTS OF STANDARD CHARACTERS
 WITHOUT CLAIM TO ANY PARTICULAR FONT, STYLE,
 SIZE, OR COLOR.

NO CLAIM IS MADE TO THE EXCLUSIVE RIGHT TO
 USE "GREEN", APART FROM THE MARK AS SHOWN.

FOR CLEANING OF PORTABLE CONTAINERS,
 NAMELY, PUSH CARTS, HAND CARRY BASKETS
 AND FOOD TRAYS VIA AN ENVIRONMENTALLY
 FRIENDLY MOBILE CLEANING, SANITIZING AND
 BACTERIAL PROTECTION SYSTEM COMPRISED OF A
 STEAM CLEANING APPARATUS (U.S. CLS. 100, 103
 AND 106).

EMILY CHUO, EXAMINING ATTORNEY

SN 85-446,110. ALLIED CLEANING SERVICES, LLC, POSEN,
 IL. FILED 10-12-2011.

Got Bed Bugs?

THE MARK CONSISTS OF STANDARD CHARACTERS
 WITHOUT CLAIM TO ANY PARTICULAR FONT, STYLE,
 SIZE, OR COLOR.

FOR PEST CONTROL AND EXTERMINATION OTHER
 THAN FOR AGRICULTURAL PURPOSES (U.S. CLS. 100,
 103 AND 106).

FIRST USE 11-1-2009; IN COMMERCE 11-1-2009.
 HANNO RITTNER, EXAMINING ATTORNEY

CLASS 37—(Continued).

SN 85-446,418. PREVENTREX, INC., ST. PETERSBURG, FL. FILED 10-13-2011.

LEADING THE WAY AGAINST GERMS

THE MARK CONSISTS OF STANDARD CHARACTERS WITHOUT CLAIM TO ANY PARTICULAR FONT, STYLE, SIZE, OR COLOR.

FOR SANITATION SERVICES, NAMELY, SANITIZING AND DISINFECTING SURFACES OF BUILDING STRUCTURES AND EQUIPMENT AND FIXTURES WITHIN BUILDING STRUCTURES (U.S. CLS. 100, 103 AND 106).

MAYUR VAGHANI, EXAMINING ATTORNEY

SN 85-446,523. TURBINE GENERATOR MAINTENANCE, INC., CAPE CORAL, FL. FILED 10-13-2011.

Total Turbine Care

THE MARK CONSISTS OF STANDARD CHARACTERS WITHOUT CLAIM TO ANY PARTICULAR FONT, STYLE, SIZE, OR COLOR.

NO CLAIM IS MADE TO THE EXCLUSIVE RIGHT TO USE "TURBINE CARE", APART FROM THE MARK AS SHOWN.

FOR MAINTENANCE, REPAIR, REPLACEMENT AND TUNING OF COMPONENTS, PARTS OR SYSTEMS IN STEAM AND GAS TURBINE GENERATORS (U.S. CLS. 100, 103 AND 106).

FIRST USE 10-3-2011; IN COMMERCE 10-3-2011.
AMY C. KEAN, EXAMINING ATTORNEY

SN 85-446,644. TURBINE GENERATOR MAINTENANCE, INC., CAPE CORAL, FL. FILED 10-13-2011.



OWNER OF U.S. REG. NO. 2,114,840.

THE COLOR(S) WHITE, BLACK, LIGHT BLUE, DARK BLUE AND GRAY IS/ARE CLAIMED AS A FEATURE OF THE MARK.

THE MARK CONSISTS OF THE DESIGN OF A MAN IN THE COLORS WHITE AND BLACK WEARING A LIGHT BLUE AND DARK BLUE UNIFORM WITH BLACK OUT-

CLASS 37—(Continued).

LINING WITH THE STYLIZED WORDING "MR. TURBINE" IN BLACK LETTERING OVER THE RIGHT CHEST POCKET, WORK BOOTS IN LIGHT BLUE WITH BLACK OUTLINING, A HARD HAT IN LIGHT BLUE WITH BLACK OUTLINING WITH THE STYLIZED WORDING "TGM" IN BLACK LETTERING ABOVE THE BRIM AND LIGHT BLUE GLOVES WITH BLACK OUTLINING HOLDING A TURBINE OVER HIS LEFT SHOULDER IN BLACK, WHITE AND GRAY ALL APPEARING OVER A DARK BLUE OVAL WITH LIGHT BLUE OUTLINING.

FOR MAINTENANCE, REPAIR, REPLACEMENT AND TUNING OF COMPONENTS, PARTS OR SYSTEMS IN STEAM AND GAS TURBINE GENERATORS (U.S. CLS. 100, 103 AND 106).

FIRST USE 10-3-2011; IN COMMERCE 10-3-2011.
AMY C. KEAN, EXAMINING ATTORNEY

SN 85-446,842. SOLUTIONS TO AUTOMOTIVE RECONDITIONING LLC, CENTENNIAL, CO. FILED 10-13-2011.



NO CLAIM IS MADE TO THE EXCLUSIVE RIGHT TO USE "SOLUTIONS TO AUTOMOTIVE RECONDITIONING", APART FROM THE MARK AS SHOWN.

THE COLOR(S) YELLOW AND BLACK IS/ARE CLAIMED AS A FEATURE OF THE MARK.

THE MARK CONSISTS OF A STYLIZED REPRESENTATION OF AN AUTOMOBILE WITH A YELLOW TOP OUTLINE AND BLACK BODY OUTLINE, A BLACK STAR IN THE AUTOMOBILE WINDOW AREA, AND THE WORDS "SOLUTIONS TO AUTOMOTIVE RECONDITIONING" WITH THE INITIAL LETTER OF EACH WORD CAPITALIZED AND IN YELLOW AND THE REMAINING LETTERS OF EACH WORD NOT CAPITALIZED AND IN BLACK.

FOR AUTOMOBILE DETAILING; AUTOMOBILE RECONDITIONING SERVICES (U.S. CLS. 100, 103 AND 106).

FIRST USE 10-12-2011; IN COMMERCE 10-12-2011.
ASMAT KHAN, EXAMINING ATTORNEY

SN 85-447,742. EM CONSULTING GROUP, INC., TIMONIUM, MD. FILED 10-14-2011.

HELION

THE MARK CONSISTS OF STANDARD CHARACTERS WITHOUT CLAIM TO ANY PARTICULAR FONT, STYLE, SIZE, OR COLOR.

FOR INSTALLATION, REPAIR AND MAINTENANCE OF COMPUTERS AND COMPUTER PERIPHERALS; MAINTENANCE AND REPAIR OF COMPUTER NETWORKING HARDWARE; MAINTENANCE OF COMPUTER HARDWARE SYSTEMS (U.S. CLS. 100, 103 AND 106).

FIRST USE 2-1-2005; IN COMMERCE 2-1-2005.
HOWARD SMIGA, EXAMINING ATTORNEY

CLASS 37—(Continued).

SN 85-448,205. VIVOPOOLS, LLC, LA CANADA, CA. FILED 10-14-2011.



OWNER OF U.S. REG. NO. 4,091,907.
THE COLOR(S) BLUE, WHITE AND YELLOW IS/ARE CLAIMED AS A FEATURE OF THE MARK.

THE MARK CONSISTS OF A DESIGN ELEMENT CONSISTING OF A CIRCLE, INSIDE WHICH ARE A BLUE STYLIZED WAVE AND A YELLOW STYLIZED SUN, SEPARATED BY WHITE; AND THE WORD ELEMENT "VIVOPOOLS" IN BLUE.

FOR SWIMMING POOL AND SPA CLEANING SERVICES; SWIMMING POOL AND SPA MAINTENANCE; REPAIR OR MAINTENANCE OF SWIMMING POOLS AND SPAS (U.S. CLS. 100, 103 AND 106).

FIRST USE 5-5-2010; IN COMMERCE 9-20-2011.
NAAKWAMA ANKRAH, EXAMINING ATTORNEY

SN 85-448,473. SERVICES OF AMERICA, LLC, ALEXANDRIA, VA. FILED 10-16-2011.



NO CLAIM IS MADE TO THE EXCLUSIVE RIGHT TO USE THE OUTLINE OF THE CONTIGUOUS UNITED STATES, FILLED IN WITH RED AND WHITE STRIPES, APART FROM THE MARK AS SHOWN.

THE COLOR(S) RED, WHITE, AND BLUE IS/ARE CLAIMED AS A FEATURE OF THE MARK.

THE MARK CONSISTS OF THE OUTLINE OF THE CONTIGUOUS UNITED STATES, FILLED IN WITH ALTERNATING RED AND WHITE STRIPES, THE ACRONYM CONSISTING OF THE LETTERS S AND O AND A IN BLUE LETTERING OUTLINED IN WHITE, LOCATED CENTRALLY WITHIN THE MARK, AND A BLUE STAR LOCATED IN THE UPPER LEFT CORNER OF THE IMAGE, ALSO OUTLINED IN WHITE.

FOR JANITORIAL SERVICES (U.S. CLS. 100, 103 AND 106).

FIRST USE 11-0-2009; IN COMMERCE 11-0-2009.
JILL C. ALT, EXAMINING ATTORNEY

CLASS 37—(Continued).

SN 85-448,905. RELIABLE COMPUTER TECHS, YONKERS, NY. FILED 10-17-2011.

The company where
"computer" is our middle
name

THE MARK CONSISTS OF STANDARD CHARACTERS WITHOUT CLAIM TO ANY PARTICULAR FONT, STYLE, SIZE, OR COLOR.

FOR REPAIR OF COMPUTER HARDWARE (U.S. CLS. 100, 103 AND 106).

THEODORE MCBRIDE, EXAMINING ATTORNEY

SN 85-448,938. CINERAMAX SPECIAL VENUES LLC, MIAMI, FL. FILED 10-17-2011.

CINERAMAX

THE MARK CONSISTS OF STANDARD CHARACTERS WITHOUT CLAIM TO ANY PARTICULAR FONT, STYLE, SIZE, OR COLOR.

FOR INSTALLATION OF HOME THEATRES AND RELATED STRUCTURED WIRING (U.S. CLS. 100, 103 AND 106).

FIRST USE 7-28-2000; IN COMMERCE 1-3-2003.
TARAH HARDY, EXAMINING ATTORNEY

SN 85-450,410. HORKY, ROBERT, SAN ANSELMO, CA. FILED 10-18-2011.



NO CLAIM IS MADE TO THE EXCLUSIVE RIGHT TO USE "GREEN HEATING", APART FROM THE MARK AS SHOWN.

THE MARK CONSISTS OF A STYLIZED YIN-YANG SYMBOL ENCLOSED WITHIN A CIRCLE WITHIN WHICH IS LOCATED THE WORDING "GREEN HEATING."

FOR INSTALLATION, REPAIR AND REPLACEMENT SERVICE FOR HEATING, COOLING, GEOTHERMAL, VENTILATING AND AIR CONDITIONING SYSTEMS USING SOLAR ENERGY AND RENEWABLE ENERGY RESOURCES (U.S. CLS. 100, 103 AND 106).

FIRST USE 8-25-2010; IN COMMERCE 8-25-2010.
NAPOLEON SHARMA, EXAMINING ATTORNEY

CLASS 37—(Continued).

SN 85-451,875. ALEXANDER R. ISER, TULSA, OK. FILED 10-20-2011.

PHONE DOCTORS

THE MARK CONSISTS OF STANDARD CHARACTERS WITHOUT CLAIM TO ANY PARTICULAR FONT, STYLE, SIZE, OR COLOR.

OWNER OF U.S. REG. NO. 3,824,790.

NO CLAIM IS MADE TO THE EXCLUSIVE RIGHT TO USE "PHONE", APART FROM THE MARK AS SHOWN FOR REPAIR AND MAINTENANCE OF CELLULAR TELEPHONES (U.S. CLS. 100, 103 AND 106).

FIRST USE 12-7-2009; IN COMMERCE 12-7-2009.

VERNA BETH RIRIE, EXAMINING ATTORNEY

CLASS 37—(Continued).

SN 85-460,458. YOUNG, GREGG WHEELER, AUSTIN, TX. FILED 10-31-2011.

BERNARD JOHNSON

SN 85-456,919. EXPEST EXTERMINATING, INC., SNELLVILLE, GA. FILED 10-26-2011.



THE COLOR(S) BLACK AND RED IS/ARE CLAIMED AS A FEATURE OF THE MARK.

THE MARK CONSISTS OF A LARGE BLACK LETTER "X" IN A THICK FONT WITH A BOX IN THE MIDDLE WITH "EXPEST" WRITTEN IN THE BOX IN RED. THE COLOR WHITE IS NOT CLAIMED AS A FEATURE OF THE MARK. THE COLOR WHITE MERELY REPRESENTS TRANSPARENT AREAS AND IS NOT PART OF THE MARK.

FOR EXTERMINATING CONSULTATION; PEST CONTROL AND EXTERMINATION OTHER THAN FOR AGRICULTURAL PURPOSES; VERMIN EXTERMINATION OTHER THAN FOR AGRICULTURE (U.S. CLS. 100, 103 AND 106).

FIRST USE 2-5-1990; IN COMMERCE 2-5-1990.

ADA HAN, EXAMINING ATTORNEY

THE NAME(S), PORTRAIT(S), AND/OR SIGNATURE(S) SHOWN IN THE MARK DOES NOT IDENTIFY A PARTICULAR LIVING INDIVIDUAL.

THE COLOR(S) BLUE IS/ARE CLAIMED AS A FEATURE OF THE MARK.

THE MARK CONSISTS OF THE WORDS "BERNARD JOHNSON" IN BLOCK LETTERS IN BLUE.

FOR BUILDING CAULKING SERVICES; BUILDING CONSTRUCTION SERVICES; BUILDING SEALING AND CAULKING SERVICES; CONSTRUCTION GRADING SERVICES; CONSTRUCTION PROJECT MANAGEMENT SERVICES; CONSTRUCTION PROJECT MANAGEMENT SERVICES IN THE FIELD OF CONSTRUCTION OF RENEWABLE ENERGY AND ENERGY GENERATION EQUIPMENT SUPPORT STRUCTURES AND ANCILLARY STRUCTURES FOR SUPPORTING METEOROLOGICAL DATA GATHERING EQUIPMENT; CONSULTATION SERVICES IN THE FIELD OF CONSTRUCTION OF ENVIRONMENTALLY-CONSCIOUS BUILDINGS; CONSULTING SERVICES IN THE FIELD OF CONSTRUCTION OF WIND ENERGY FACILITIES; DAMP PROOFING SERVICES; ELECTRICAL CONTRACTOR SERVICES; GENERAL BUILDING CONTRACTOR SERVICES; GENERAL CONTRACTING SERVICES IN THE FIELD OF FLOORING; GENERAL CONTRACTOR SERVICES, NAMELY, PLUMBING, HEATING AND AIR CONDITIONING, CARPENTRY, DRYWALL, PAINTING, ELECTRICAL, BUILDING AND FRAMING CONTRACTOR SERVICES; HEATING CONTRACTOR SERVICES; HOME ENERGY ASSESSMENT SERVICES FOR THE PURPOSE OF DETERMINING HOME IMPROVEMENTS NEEDED TO IMPROVE ENERGY USE AND EFFICIENCY; HVAC CONTRACTOR SERVICES; INSPECTION SERVICES IN THE COURSE OF CONSTRUCTION OF DAMS, BRIDGES, NEW COMMERCIAL AND RESIDENTIAL BUILDINGS; MECHANIC SERVICES; MECHANICAL CONTRACTOR SERVICES; PLUMBING CONTRACTOR SERVICES; PLUMBING SERVICES; TECHNICAL SUPPORT SERVICES, NAMELY, TROUBLESHOOTING IN THE NATURE OF THE REPAIR OF COMPUTER HARDWARE (U.S. CLS. 100, 103 AND 106).

ANDREA BUTLER, EXAMINING ATTORNEY

CLASS 37—(Continued).

SN 85-463,192. YOUNG, GREGG WHEELER, AUSTIN, TX. FILED 11-3-2011.

BERNARD JOHNSON GROUP

NO CLAIM IS MADE TO THE EXCLUSIVE RIGHT TO USE "GROUP", APART FROM THE MARK AS SHOWN.

THE NAME "BERNARD JOHNSON" DOES NOT IDENTIFY A LIVING INDIVIDUAL.

THE COLOR(S) BLUE IS/ARE CLAIMED AS A FEATURE OF THE MARK.

THE MARK CONSISTS OF THE WORDS "BERNARD JOHNSON GROUP" IN BLOCK LETTERS IN BLUE.

FOR BUILDING CAULKING SERVICES; BUILDING CONSTRUCTION SERVICES; BUILDING SEALING AND CAULKING SERVICES; CONSTRUCTION PROJECT MANAGEMENT SERVICES; CONSTRUCTION SERVICES, NAMELY, PLANNING, LAYING OUT AND CONSTRUCTION OF A PLANNED RESIDENTIAL COMMUNITY; CONSTRUCTION SERVICES, NAMELY, PLANNING, LAYING OUT AND CONSTRUCTION OF RESIDENTIAL AND COMMERCIAL COMMUNITIES; CONSTRUCTION SERVICES, NAMELY, PLANNING, LAYING OUT AND CUSTOM CONSTRUCTION OF COMMERCIAL BUILDINGS; CONSTRUCTION SERVICES, NAMELY, PLANNING, LAYING OUT AND CUSTOM CONSTRUCTION OF RESIDENTIAL AND COMMERCIAL COMMUNITIES; CONSULTING SERVICES IN THE FIELD OF CONSTRUCTION OF WIND ENERGY FACILITIES; DAMP PROOFING SERVICES; GENERAL BUILDING CONTRACTOR SERVICES; GENERAL CONTRACTING SERVICES IN THE FIELD OF FLOORING; HVAC CONTRACTOR SERVICES; PLUMBING CONTRACTOR SERVICES; PLUMBING SERVICES (U.S. CLS. 100, 103 AND 106).

ANDREA BUTLER, EXAMINING ATTORNEY

SN 85-482,674. MAYTAG PROPERTIES, LLC, ST. JOSEPH, MI. FILED 11-29-2011.

MAYTAG

THE MARK CONSISTS OF STANDARD CHARACTERS WITHOUT CLAIM TO ANY PARTICULAR FONT, STYLE, SIZE, OR COLOR.

OWNER OF U.S. REG. NOS. 2,638,631, 3,811,414 AND OTHERS.

FOR PROVIDING WASHING AND DRYING LAUNDRY FACILITIES; SELF-SERVICE LAUNDRIES (U.S. CLS. 100, 103 AND 106).

DAVID H. STINE, EXAMINING ATTORNEY

CLASS 37—(Continued).

SN 85-508,285. PREVENTREX, INC., ST. PETERSBURG, FL. FILED 1-4-2012.

HEALTHIER YOU. HAPPIER LIFE.

THE MARK CONSISTS OF STANDARD CHARACTERS WITHOUT CLAIM TO ANY PARTICULAR FONT, STYLE, SIZE, OR COLOR.

FOR SANITATION SERVICES, NAMELY, SANITIZING AND DISINFECTING SURFACES OF BUILDING STRUCTURES AND EQUIPMENT AND FIXTURES WITHIN BUILDING STRUCTURES (U.S. CLS. 100, 103 AND 106).

MAYUR VAGHANI, EXAMINING ATTORNEY

CLASS 38—COMMUNICATION

SN 85-018,674. AOL INC., DULLES, VA. FILED 4-20-2010.

BEAT THE INTERNET

THE MARK CONSISTS OF STANDARD CHARACTERS WITHOUT CLAIM TO ANY PARTICULAR FONT, STYLE, SIZE, OR COLOR.

NO CLAIM IS MADE TO THE EXCLUSIVE RIGHT TO USE "INTERNET", APART FROM THE MARK AS SHOWN.

FOR ELECTRONIC TRANSMISSION OF DATA, IMAGES, DOCUMENTS, MESSAGES, VIDEO, AND SOUND VIA COMPUTER NETWORKS AND DIGITAL NETWORKS; PROVIDING MULTIPLE USER ACCESS TO COMPUTER AND DIGITAL NETWORKS; PROVIDING ONLINE COMPUTER AND DIGITAL NETWORK FACILITIES FOR REAL TIME INTERACTION AND COMMUNICATION WITH OTHER COMPUTER AND DIGITAL USERS CONCERNING TOPICS OF GENERAL INTEREST; TELECOMMUNICATIONS SERVICES, NAMELY, PERSONAL COMMUNICATION SERVICES; PROVIDING ONLINE CHAT ROOMS FOR TRANSMISSION OF MESSAGES, DOCUMENTS, IMAGES, AND DATA CONCERNING TOPICS OF GENERAL INTEREST; PROVIDING ONLINE FORUMS FOR TRANSMISSION OF MESSAGES, DOCUMENTS, IMAGES, AND DATA AMONG USERS CONCERNING TOPICS OF GENERAL INTEREST; ELECTRONIC MAIL SERVICES; STREAMING OF AUDIO, VISUAL, AND AUDIOVISUAL MATERIAL VIA COMPUTER AND DIGITAL NETWORKS; BROADCASTING OF RADIO PROGRAMS; DELIVERY OF DIGITAL MUSIC BY ELECTRONIC TRANSMISSION; TRANSMISSION OF DIGITAL AUDIO AND VIDEO FILES VIA COMPUTER AND DIGITAL NETWORKS (U.S. CLS. 100, 101 AND 104).

CORY BOONE, EXAMINING ATTORNEY

CLASS 38—(Continued).

SN 85-128,178. CJ 4DPLEX CO., LTD., SEOUL, REPUBLIC OF KOREA, FILED 9-13-2010.

4DPLEX

THE MARK CONSISTS OF STANDARD CHARACTERS WITHOUT CLAIM TO ANY PARTICULAR FONT, STYLE, SIZE, OR COLOR.

PRIORITY CLAIMED UNDER SEC. 44(D) ON REPUBLIC OF KOREA APPLICATION NO. 41-2010-2347, FILED 9-10-2010, REG. NO. 0223563, DATED 12-23-2011, EXPIRES 12-23-2021.

FOR BROADCASTING MOVIES; BROADCASTING MOVIES FEATURING MOVIES AUDIENCE EFFECTS SUCH AS WIND, SCENT, WATER SPRAY, MOTION, VIBRATION, SMOKE, BUBBLE, LASER OR FLASH; CABLE TELEVISION BROADCASTING; RADIO BROADCASTING; TELEVISION BROADCASTING; PROVIDING TELECOMMUNICATIONS CONNECTIONS TO A GLOBAL COMPUTER NETWORK; TELEPHONE SERVICES; COMPUTER AIDED TRANSMISSION OF MESSAGES AND IMAGES; WIRELESS BROADBAND COMMUNICATION SERVICES (U.S. CLS. 100, 101 AND 104).
RON FAIRBANKS, EXAMINING ATTORNEY

SN 85-149,867. GLABBER, INC., NEWARK, DE. FILED 10-11-2010.

GLABBER

THE MARK CONSISTS OF STANDARD CHARACTERS WITHOUT CLAIM TO ANY PARTICULAR FONT, STYLE, SIZE, OR COLOR.

FOR PROVIDING ELECTRONIC BULLETIN BOARD SERVICES; PROVIDING ELECTRONIC INFORMATION SHARING IN THE NATURE OF INFORMATION TRANSMISSION VIA ELECTRONIC COMMUNICATIONS NETWORKS, INCLUDING CONTENT SHARING AND SOCIAL NETWORKING; PROVIDING RATING SYSTEM SERVICES, NAMELY, ELECTRONIC TRANSMISSION OF RATINGS DATA VIA THE INTERNET; PROVIDING ELECTRONIC EMAIL SERVICES, PROVIDING INSTANT MESSAGING SERVICES; PROVIDING ON-LINE FORUMS FOR TRANSMISSION OF MESSAGES AMONG COMPUTER USERS CONCERNING GENERAL INTEREST TOPICS, CLASSIFIEDS, VIRTUAL COMMUNITIES, SOCIAL NETWORKING, PHOTO SHARING, VIDEO SHARING AND TRANSMISSION OF PHOTOGRAPHIC IMAGES; PROVIDING MULTIPLE USER ACCESS TO A GLOBAL COMPUTER INFORMATION NETWORK, PROVIDING ONLINE CHAT ROOM SERVICES; PROVIDING COMMUNICATION AND TRANSMISSION SERVICES FOR MOBILE PHONES AND PROVIDING COMMUNICATIONS BY MOBILE PHONE, ELECTRONIC TRANSMISSION OF VOICE, DATA AND IMAGES BY MOBILE PHONE; ELECTRONIC EXCHANGE OF DATA AND GRAPHICS STORED IN DATABASES ACCESSIBLE VIA TELECOMMUNICATION NETWORKS ; WEBSITE LINK SHARING SERVICES, NAMELY, ELECTRONIC TRANSMISSION OF URLS AMONG INTERNET USERS; PHOTO AND VIDEO SHARING SERVICES, NAMELY, ELECTRONIC TRANSMISSION OF DIGITAL PHOTO AND VIDEO FILES AMONG INTERNET USERS (U.S. CLS. 100, 101 AND 104).

JAMES LOVELACE, EXAMINING ATTORNEY

CLASS 38—(Continued).

SN 85-293,611. FIBERCAST CORPORATION, MANCHESTER, NH. FILED 4-13-2011.

FIBERCAST

THE MARK CONSISTS OF STANDARD CHARACTERS WITHOUT CLAIM TO ANY PARTICULAR FONT, STYLE, SIZE, OR COLOR.

FOR CABLE RADIO TRANSMISSION; CABLE TELEVISION TRANSMISSION; COMMUNICATION SERVICES, NAMELY, TRANSMISSION OF VOICE, AUDIO, VISUAL IMAGES AND DATA BY TELECOMMUNICATIONS NETWORKS, WIRELESS COMMUNICATION NETWORKS, THE INTERNET, INFORMATION SERVICES NETWORKS AND DATA NETWORKS; COMMUNICATIONS BY TELEPHONE; DATA TRANSMISSION AND RECEPTION SERVICES VIA TELECOMMUNICATION MEANS; LOCAL AND LONG DISTANCE TELEPHONE SERVICES; PROVIDING A HIGH SPEED ACCESS TO AREA NETWORKS AND A GLOBAL COMPUTER INFORMATION NETWORK (U.S. CLS. 100, 101 AND 104).

FIRST USE 3-27-2006; IN COMMERCE 3-27-2006.
BILL DAWE, EXAMINING ATTORNEY

SN 85-377,043. HUBBELL INCORPORATED, SHELTON, CT. FILED 7-21-2011.

BURNDYLink

THE MARK CONSISTS OF THE WORDING "BURNDY-LINK" WITH A SIGNAL DESIGN CONSISTING OF THREE CURVED LINES OVER THE LETTER "K".

FOR TRANSMISSION OF ONLINE BASED INFORMATION ACCESSED VIA A VISUAL REFERENCE, NAMELY, A QR CODE OR OTHER VISUAL CODES AND BARCODES VIA COMPUTER OR MOBILE DEVICES, OR ANY COMBINATION THEREOF FOR PURPOSES OF SHARING, DISTRIBUTING AND ADVERTISING INFORMATION ABOUT ELECTRICAL AND ELECTRONIC CONNECTORS AND TOOLS (U.S. CLS. 100, 101 AND 104).

TRACY WHITTAKER-BROWN, EXAMINING ATTORNEY

CLASS 38—(Continued).

SN 85-409,456. PATRICK NETTER, LOS ANGELES, CA. FILED 8-29-2011.



NO CLAIM IS MADE TO THE EXCLUSIVE RIGHT TO USE "CONSUMER TV", APART FROM THE MARK AS SHOWN.

THE NAME "PATRICK NETTER" IDENTIFIES A LIVING INDIVIDUAL WHOSE CONSENT IS OF RECORD.

THE MARK CONSISTS OF THE STYLIZED WORDS "PATRICK NETTER'S" CENTERED ABOVE THE WORDS "BOOMER CONSUMER" IN STYLIZED FONT. TO THE RIGHT OF THE WORDS "BOOMER CONSUMER" IS A DRAWING OF A TELEVISION SET WITH THE STYLIZED INITIALS "TV" ON THE SCREEN.

FOR BROADCAST OF EDUCATION, ENTERTAINMENT AND NEWS MEDIA OVER SATELLITE, CABLE, THE INTERNET AND CELLULAR NETWORKS (U.S. CLS. 100, 101 AND 104).

FIRST USE 8-4-2011; IN COMMERCE 8-4-2011.
KRISTINA MORRIS, EXAMINING ATTORNEY

CLASS 38—(Continued).

SN 85-412,680. THE RICHARD STOCKTON COLLEGE OF NEW JERSEY, POMONA, NJ. FILED 9-1-2011.

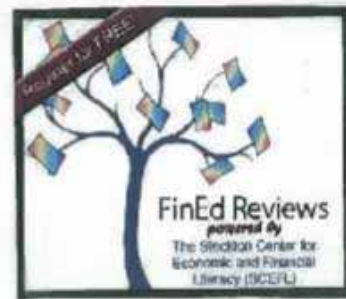

SN 85-410,945. THE RICHARD STOCKTON COLLEGE OF NEW JERSEY, POMONA, NJ. FILED 8-30-2011.

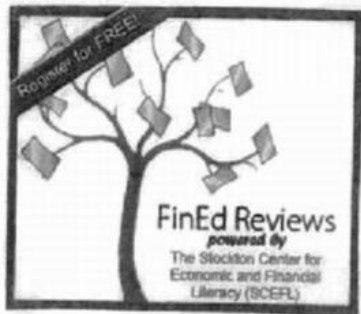

NO CLAIM IS MADE TO THE EXCLUSIVE RIGHT TO USE "REGISTER FOR FREE", "FIN ED REVIEWS" AND "CENTER FOR ECONOMIC AND FINANCIAL LITERACY", APART FROM THE MARK AS SHOWN.

THE MARK CONSISTS OF A SQUARE BORDER WITH A STYLIZED TREE WITH A TRUNK EXTENDING FROM THE BOTTOM BORDER IN THE SPACE FORMED BY THE BORDER, AND STYLIZED LEAVES EXTENDING FROM BRANCHES ATTACHED TO THE TRUNK WITH THE TERM "REGISTER FOR FREE" IN A DIAGONAL BAND AT AN UPPER LEFT HAND CORNER OF THE INTERIOR SPACE AND THE LITERAL ELEMENTS "FINED REVIEWS POWERED BY THE STOCKTON CENTER FOR ECONOMIC AND FINANCIAL LITERACY (SCEFL)" IN THE LOWER RIGHT HAND CORNER OF THE INTERIOR SPACE.

FOR PROVIDING ON-LINE FACILITIES FOR REAL-TIME INTERACTION WITH COMPUTER USERS CONCERNING TOPICS OF INTEREST RELATING TO FINANCIAL LITERACY, NAMELY, PROVIDING A MODERATED WEBSITE FOR THE RATING OF FINANCIAL LITERACY MATERIALS BASED ON SCHOLARLY RESEARCH IN THE FIELD OF BEST PRACTICES IN EDUCATIONAL CURRICULAR DESIGN AND INSTRUCTION FOR PRE-KINDERGARTEN TO ADULT EDUCATION (U.S. CLS. 100, 101 AND 104).

FIRST USE 6-7-2011; IN COMMERCE 6-7-2011.
MARY CRAWFORD, EXAMINING ATTORNEY

NO CLAIM IS MADE TO THE EXCLUSIVE RIGHT TO USE "REGISTER FOR FREE" AND "FIN ED REVIEWS" AND "CENTER FOR ECONOMIC AND FINANCIAL LITERACY", APART FROM THE MARK AS SHOWN.

THE COLOR(S) BLACK, RUST, BLUE, YELLOW, GREEN, ORANGE AND WHITE IS/ARE CLAIMED AS A FEATURE OF THE MARK.

THE MARK CONSISTS OF A SQUARE BLACK BORDER WITH A WHITE INTERIOR HAVING A DIAGONAL RUST COLORED BAND IN THE UPPER LEFT CORNER OF THE INTERIOR SPACE, WITH THE LITERAL ELEMENTS "REGISTER FOR FREE" IN WHITE IN THE BAND, A BLUE TREE WITH BLUE BRANCHES HAVING MULTICOLORED STYLIZED LEAVES OF BLUE, GREEN, YELLOW, ORANGE AND THE LITERAL ELEMENT "FINED REVIEWS" IN BLACK FOLLOWED BY "POWERED BY" IN RUST COLOR, FOLLOWED BY "THE STOCKTON CENTER FOR ECONOMIC AND FINANCIAL LITERACY (SCEFL)" IN BLACK IN THE LOWER RIGHT HAND CORNER OF THE INTERIOR SPACE.

FOR PROVIDING ON-LINE FACILITIES FOR REAL-TIME INTERACTION WITH COMPUTER USERS CONCERNING TOPICS OF INTEREST RELATING TO FINANCIAL LITERACY, NAMELY, PROVIDING A MODERATED WEBSITE FOR THE RATING OF FINANCIAL LITERACY MATERIALS BASED ON SCHOLARLY RESEARCH IN THE FIELD OF BEST PRACTICES IN EDUCATIONAL CURRICULAR DESIGN AND INSTRUCTION FOR PRE-KINDERGARTEN TO ADULT EDUCATION (U.S. CLS. 100, 101 AND 104).

FIRST USE 6-7-2011; IN COMMERCE 6-7-2011.
MARY CRAWFORD, EXAMINING ATTORNEY

CLASS 38—(Continued).

SN 85-421,806. LINGO LOUNGE, LLC, ANCHORAGE, AK.
FILED 9-13-2011.

LINGO LOUNGE

THE MARK CONSISTS OF STANDARD CHARACTERS WITHOUT CLAIM TO ANY PARTICULAR FONT, STYLE, SIZE, OR COLOR.

FOR PROVIDING ACCESS TO COMPUTER DATABASES IN THE FIELD OF SOCIAL NETWORKING; PEER-TO-PEER NETWORK COMPUTER SERVICES, NAMELY, ELECTRONIC TRANSMISSION OF AUDIO, VIDEO AND OTHER DATA AND DOCUMENTS AMONG COMPUTERS FEATURING USER PROFILE INFORMATION, DIGITAL PHOTO FILES, DIGITAL MUSIC FILES, DIGITAL VIDEO FILES, BLOG SHARING, AND WEBLINK INFORMATION AMONG INTERNET USERS; PROVIDING ELECTRONIC TRANSMISSION SERVICES VIA THE INTERNET AND MOBILE COMMUNICATIONS DEVICES SO THAT USERS OF BLOG NETWORKS AND MULTIMEDIA NETWORKS MAY ACCESS USER PROFILE INFORMATION, SEND MESSAGES TO USERS, POST INFORMATION VIEWABLE TO USERS AND ACCESS CONTACT INFORMATION (U.S. CLS. 100, 101 AND 104).

CHRISTOPHER LAW, EXAMINING ATTORNEY

SN 85-421,809. LINGO LOUNGE, LLC, ANCHORAGE, AK.
FILED 9-13-2011.



THE MARK CONSISTS OF TWO STYLIZED "L" LETTERS, A SMALLER "L" LETTER SITTING ON TOP OF THE LARGER "L" LETTER AND BOTH OF WHICH ARE CONTAINED WITHIN A PARALLELOGRAM, THE SAME PARALLELOGRAM OVERLAPPING A SECOND AND A THIRD PARALLELOGRAM.

FOR PROVIDING ACCESS TO COMPUTER DATABASES IN THE FIELD OF SOCIAL NETWORKING; PEER-TO-PEER NETWORK COMPUTER SERVICES, NAMELY, ELECTRONIC TRANSMISSION OF AUDIO, VIDEO AND OTHER DATA AND DOCUMENTS AMONG COMPUTERS FEATURING USER PROFILE INFORMATION, DIGITAL PHOTO FILES, DIGITAL MUSIC FILES, DIGITAL VIDEO FILES, BLOG SHARING, AND WEBLINK INFORMATION AMONG INTERNET USERS; PROVIDING ELECTRONIC TRANSMISSION SERVICES VIA THE INTERNET AND MOBILE COMMUNICATIONS DEVICES SO THAT USERS OF BLOG NETWORKS AND MULTIMEDIA NETWORKS MAY ACCESS USER PROFILE INFORMATION, SEND MESSAGES TO USERS, POST INFORMATION VIEWABLE TO USERS AND ACCESS CONTACT INFORMATION (U.S. CLS. 100, 101 AND 104).

CHRISTOPHER LAW, EXAMINING ATTORNEY

CLASS 38—(Continued).

SN 85-423,960. INTERNATIONAL MEDIA CONTENT LTD,
CASTRIES, ST.LUCIA, FILED 9-15-2011.



NO CLAIM IS MADE TO THE EXCLUSIVE RIGHT TO USE "TV", APART FROM THE MARK AS SHOWN.

THE MARK CONSISTS OF THE TERM "CEE" IN STYLIZED LETTERS WITH A LINE DESIGN BELOW IT AND THE TERM "TV" IN STYLIZED LETTERS WITHIN A CIRCLE TO THE TOP RIGHT.

FOR TELEVISION BROADCASTING SERVICES; SUBSCRIPTION TELEVISION BROADCASTING; VIDEO-ON-DEMAND TRANSMISSION SERVICES; CABLE AND/OR SATELLITE TELEVISION BROADCASTING SERVICES; INTERNET PROTOCOL TELEVISION (IPTV) TRANSMISSION SERVICES (U.S. CLS. 100, 101 AND 104).

DOMINICK J. SALEMI, EXAMINING ATTORNEY

SN 85-423,973. AT&T INTELLECTUAL PROPERTY II, L.P.,
RENO, NV. FILED 9-15-2011.

**NO DRAWING-SENSORY
MARK**

THE MARK IS A SOUND. THE MARK IS IN THE KEY OF G-MAJOR, AND BEGINS WITH A SYNTHESIZED BELL SOUND PLAYING A D4 DOTTED QUARTER NOTE,

CLASS 38—(Continued).

FOLLOWED BY A D5 EIGHTH NOTE THAT IS TIED TO A D5 QUARTER NOTE, THEN AN E5 QUARTER NOTE THAT IS TIED TO AN E5 EIGHTH NOTE, AND FINALLY A B4 QUARTER NOTE. THE SYNTHESIZED BELL IS PLAYED IN A STOCATTO MANNER. AS THE SOUND BEGINS, SYNTHESIZED STRINGS PLAYING A G5 CHORD SLOWLY FADE IN, AND LAST THE DURATION. A SNAP SOUND OCCURS AT THE SAME MOMENT THE FINAL B4 QUARTER NOTE IS PLAYED, AND IS PRECEDED BY THE SOUND OF A SHORT REVERSE ECHO OF THE SNAP.

FOR TELECOMMUNICATIONS SERVICES, NAMELY, PROVIDING TELEPHONE COMMUNICATION AND INTERNET TELEPHONY SERVICES; PROVIDING TELEPHONE COMMUNICATIONS SERVICES THAT PROVIDE A GROUP OF SPECIALIZED TELEPHONE SERVICES WITH CUSTOM CALLING FEATURES AND TELEPHONE CALLING PLANS; ELECTRONIC VOICE MESSAGING, NAMELY, THE RECORDING AND SUBSEQUENT TRANSMISSION OF VOICE MESSAGES BY TELEPHONE; PROVIDING MULTIPLE USER DIAL-UP, HIGH-SPEED AND DEDICATED ACCESS TO THE INTERNET; ELECTRONIC TRANSMISSION OF MESSAGES, DATA, IMAGES, VIDEO AND INFORMATION VIA THE INTERNET; WIRELESS TRANSMISSION OF VOICE, MESSAGES, DATA AND INFORMATION; HIGH-SPEED ACCESS SERVICES AND WIRELESS ACCESS SERVICES TO THE INTERNET; TELEVISION TRANSMISSION SERVICES; TELECOMMUNICATIONS SERVICES IN THE NATURE OF PROVIDING VOICE AND DATA NETWORKING SERVICES, NAMELY, PROVIDING DIGITAL AND ANALOG NETWORKING SERVICES TO TRANSMIT DATA AND VOICE; TELECONFERENCING, VIDEOCONFERENCING AND WEB CONFERENCING SERVICES; CELLULAR AND MOBILE TELEPHONE COMMUNICATIONS; TELECOMMUNICATIONS CONSULTATION; VOICE OVER INTERNET PROTOCOL (VOIP) SERVICES; TELECOMMUNICATIONS CONSULTATION IN THE FIELD OF DATA, VOICE AND VIDEO COMMUNICATIONS NETWORKS (U.S. CLS. 100, 101 AND 104).

JASON BLAIR, EXAMINING ATTORNEY

SN 85-425,809. VOX GROUP INTERNATIONAL, INC., NEW YORK, NY. FILED 9-19-2011.



THE COLOR(S) RED, BLACK AND WHITE IS/ARE CLAIMED AS A FEATURE OF THE MARK.

THE MARK CONSISTS OF "VOX ME" IN RED WITH A THIN WHITE BORDER WHICH ARE THEN BORDERED IN BLACK. THE "O" IN "VOX" IS A RED AND WHITE GLOBE. THE BOTTOM RIGHT OF THE LETTER "X" EXTENDS INTO A LINE ON WHICH THE WORD "ME" SITS.

THE ENGLISH TRANSLATION OF THE WORD "VOX" IN THE MARK IS "VOICE".

FOR PREPAID INTERNATIONAL TEXT MESSAGING SERVICES VIA SMS (U.S. CLS. 100, 101 AND 104).

CHRISTOPHER LAW, EXAMINING ATTORNEY

CLASS 38—(Continued).

SN 85-430,214. AMERICAN MARKETING ASSOCIATION, CHICAGO, IL. FILED 9-23-2011.

AMA TV

THE MARK CONSISTS OF STANDARD CHARACTERS WITHOUT CLAIM TO ANY PARTICULAR FONT, STYLE, SIZE, OR COLOR.

OWNER OF U.S. REG. NO. 2,301,511.

NO CLAIM IS MADE TO THE EXCLUSIVE RIGHT TO USE "TV", APART FROM THE MARK AS SHOWN.

FOR AUDIO AND VIDEO BROADCASTING SERVICES OVER THE INTERNET; AUDIO AND VIDEO BROADCASTING SERVICES OVER THE INTERNET IN THE FIELD OF MARKETING; BROADCASTING OF VIDEO AND AUDIO PROGRAMMING OVER THE INTERNET (U.S. CLS. 100, 101 AND 104).

FIRST USE 8-22-2011; IN COMMERCE 8-22-2011.

ESTHER BELENKER, EXAMINING ATTORNEY

SN 85-430,232. AMERICAN MARKETING ASSOCIATION, CHICAGO, IL. FILED 9-23-2011.



OWNER OF U.S. REG. NO. 2,301,511.

NO CLAIM IS MADE TO THE EXCLUSIVE RIGHT TO USE "TV", APART FROM THE MARK AS SHOWN.

THE MARK CONSISTS OF THE CAPITAL LETTERS "AMA" OVER THE CAPITAL LETTERS "TV" INSIDE A SQUARE BOX. ALONG THE BOTTOM EDGE OF THE BOX, THERE IS A CIRCLE BETWEEN AND BELOW THE "T" AND "V" WITH A TRIANGLE ARROW POINTING TO THE RIGHT.

FOR AUDIO AND VIDEO BROADCASTING SERVICES OVER THE INTERNET; AUDIO AND VIDEO BROADCASTING SERVICES OVER THE INTERNET IN THE FIELD OF MARKETING; BROADCASTING OF VIDEO AND AUDIO PROGRAMMING OVER THE INTERNET (U.S. CLS. 100, 101 AND 104).

FIRST USE 8-22-2011; IN COMMERCE 8-22-2011.

ESTHER BELENKER, EXAMINING ATTORNEY

CLASS 38—(Continued).

SN 85-431,392. THE SECRET TO WRITING, LLC, ATLANTA, GA. FILED 9-25-2011.

Because Words Matter

THE MARK CONSISTS OF STANDARD CHARACTERS WITHOUT CLAIM TO ANY PARTICULAR FONT, STYLE, SIZE, OR COLOR.

FOR EDUCATIONAL SERVICES, NAMELY, PROVIDING CLASSES AND TUTORING IN THE FIELD OF WRITING AND DISTRIBUTION OF COURSE AND TRAINING MATERIALS IN CONNECTION THEREWITH; PERSONAL COACHING SERVICES IN THE FIELD OF WRITING; WRITTEN TEXT EDITING FOR BUSINESS PROFESSIONALS (U.S. CLS. 100, 101 AND 104).

FIRST USE 9-1-2009; IN COMMERCE 9-5-2009.
LINDA M. KING, EXAMINING ATTORNEY

CLASS 38—(Continued).

SN 85-445,181. LYONS, JOSHUA, WASHINGTON, DC. FILED 10-12-2011.

Corporate Confidential

THE MARK CONSISTS OF STANDARD CHARACTERS WITHOUT CLAIM TO ANY PARTICULAR FONT, STYLE, SIZE, OR COLOR.

FOR PROVIDING AN ON-LINE FORUM FOR DISCUSSION OF WORK-RELATED TOPICS (U.S. CLS. 100, 101 AND 104).

LUCY ARANT, EXAMINING ATTORNEY

SN 85-446,612. WEBCAST PEOPLE, LLC, COLUMBUS, OH. FILED 10-13-2011.

WEBCAST PEOPLE

THE MARK CONSISTS OF STANDARD CHARACTERS WITHOUT CLAIM TO ANY PARTICULAR FONT, STYLE, SIZE, OR COLOR.

NO CLAIM IS MADE TO THE EXCLUSIVE RIGHT TO USE "WEBCAST", APART FROM THE MARK AS SHOWN.

FOR COMMUNICATION SERVICES, NAMELY TRANSMISSION OF ON-LINE, LIVE AND ON-DEMAND RICH MEDIA COMMUNICATIONS FOR WEBCASTING, WEBCONFERENCING, CONTENT PUBLISHING AND DIGITAL ASSET MANAGEMENT SERVICES IN A HIGHLY SECURE ENVIRONMENT (U.S. CLS. 100, 101 AND 104).

FIRST USE 9-17-2011; IN COMMERCE 9-17-2011.
ADA HAN, EXAMINING ATTORNEY

SN 85-438,309. FIRST GENESIS PROFESSIONAL SERVICE, INC., SUGAR LAND, TX. FILED 10-4-2011.



NO CLAIM IS MADE TO THE EXCLUSIVE RIGHT TO USE "HEALTH INFORMATION SERVICES EXCHANGE", APART FROM THE MARK AS SHOWN.

THE MARK CONSISTS OF A MOBIUS STRIP/RIBBON DESIGN TO THE RIGHT OF WHICH, ALL IN CAPITAL LETTERS, A FIRST LITERAL ELEMENT READS, "MOBIUS HISE", WHICH FIRST LITERAL ELEMENT IS CENTERED ALONG THE HORIZONTAL AXIS OF SAID MOBIUS STRIP/RIBBON DESIGN, AND CENTERED BELOW THE FIRST LITERAL ELEMENT IS A SECOND LITERAL ELEMENT WHICH READS, "HEALTH INFORMATION SERVICES EXCHANGE", WHICH SECOND LITERAL ELEMENT IS OF A FONT SMALLER THAN THAT OF THE FIRST LITERAL ELEMENT, AND WHERE ONLY THE FIRST LETTER OF EACH WORD OF THE SECOND LITERAL ELEMENT IS CAPITALIZED, WHERE THE MOBIUS STRIP/RIBBON DESIGN HAS A WIDTH SLIGHTLY GREATER THAN ITS HEIGHT, AND ITS BASE IS SLIGHTLY BELOW THE SECOND LITERAL ELEMENT, AND WHERE THE MOBIUS STRIP/RIBBON DESIGN CASTS A SMALL SLIGHT SHADOW BELOW THE RIGHTMOST PORTION OF THE MOBIUS STRIP/RIBBON DESIGN.

FOR ELECTRONIC EXCHANGE OF MEDICAL RECORDS ACROSS A NATIONWIDE HEALTH INFORMATION NETWORK (U.S. CLS. 100, 101 AND 104).

ELLEN BURNS, EXAMINING ATTORNEY

SN 85-446,840. ZACK LOWE, NASHVILLE, TN. FILED 10-13-2011.

StageCrave

THE MARK CONSISTS OF STANDARD CHARACTERS WITHOUT CLAIM TO ANY PARTICULAR FONT, STYLE, SIZE, OR COLOR.

FOR BROADCASTING OF VIDEO AND AUDIO PROGRAMMING OVER THE INTERNET; VIDEO BROADCASTING SERVICES OVER THE INTERNET OR OTHER COMMUNICATIONS NETWORK, NAMELY, ELECTRONICALLY TRANSMITTING VIDEO CLIPS (U.S. CLS. 100, 101 AND 104).

C. DIONNE CLYBURN, EXAMINING ATTORNEY

CLASS 38—(Continued).

SN 85-447,167. GRAIN, MICHAEL, MILTON KEYNES, UNITED KINGDOM, FILED 10-13-2011.

CLASS 38—(Continued).

SN 85-447,312. AKOO INTERNATIONAL, INC., ROSEMONT, IL. FILED 10-14-2011.

ALERTVIEW

THE MARK CONSISTS OF STANDARD CHARACTERS WITHOUT CLAIM TO ANY PARTICULAR FONT, STYLE, SIZE, OR COLOR.

FOR TELECOMMUNICATION SERVICES, NAMELY, TRANSMISSION OF VOICE, DATA, GRAPHICS, IMAGES, AUDIO AND VIDEO BY MEANS OF TELECOMMUNICATIONS NETWORKS, WIRELESS COMMUNICATION NETWORKS, DATA NETWORKS, AND THE INTERNET (U.S. CLS. 100, 101 AND 104).

DAVID TAYLOR, EXAMINING ATTORNEY

THE AKOO GIFT

THE MARK CONSISTS OF STANDARD CHARACTERS WITHOUT CLAIM TO ANY PARTICULAR FONT, STYLE, SIZE, OR COLOR.

OWNER OF U.S. REG. NO. 3,218,620.

FOR BROADCAST OF CABLE TELEVISION PROGRAMMES; BROADCASTING OF TELEVISION PROGRAMMES; BROADCASTING OF VIDEO AND AUDIO PROGRAMMING OVER THE INTERNET; BROADCASTING PROGRAMS VIA A GLOBAL COMPUTER NETWORK; CABLE TELEVISION BROADCASTING; TELEVISION BROADCASTING; VIDEO BROADCASTING SERVICES OVER THE INTERNET OR OTHER COMMUNICATIONS NETWORK, NAMELY, ELECTRONICALLY TRANSMITTING VIDEO CLIPS (U.S. CLS. 100, 101 AND 104).

ALLISON HOLTZ, EXAMINING ATTORNEY

SN 85-447,311. AKOO INTERNATIONAL, INC., ROSEMONT, IL. FILED 10-14-2011.

SN 85-447,319. QUOTEPRO, INC., CHICAGO, IL. FILED 10-14-2011.

THE GIFT

THE MARK CONSISTS OF STANDARD CHARACTERS WITHOUT CLAIM TO ANY PARTICULAR FONT, STYLE, SIZE, OR COLOR.

FOR BROADCAST OF CABLE TELEVISION PROGRAMMES; BROADCASTING OF TELEVISION PROGRAMMES; BROADCASTING OF VIDEO AND AUDIO PROGRAMMING OVER THE INTERNET; BROADCASTING PROGRAMS VIA A GLOBAL COMPUTER NETWORK; CABLE TELEVISION BROADCASTING; TELEVISION BROADCASTING; VIDEO BROADCASTING SERVICES OVER THE INTERNET OR OTHER COMMUNICATIONS NETWORK, NAMELY, ELECTRONICALLY TRANSMITTING VIDEO CLIPS (U.S. CLS. 100, 101 AND 104).

ALLISON HOLTZ, EXAMINING ATTORNEY

QUOTEPRO EXCHANGE

THE MARK CONSISTS OF STANDARD CHARACTERS WITHOUT CLAIM TO ANY PARTICULAR FONT, STYLE, SIZE, OR COLOR.

FOR PROVIDING ACCESS TO DATABASES; PROVIDING MULTIPLE USER ACCESS TO PROPRIETARY COLLECTIONS OF INFORMATION BY MEANS OF GLOBAL COMPUTER INFORMATION NETWORKS; PROVIDING MULTIPLE-USER ACCESS TO DATA ON THE INTERNET IN THE FIELD OF INSURANCE (U.S. CLS. 100, 101 AND 104).

MIDGE BUTLER, EXAMINING ATTORNEY

CLASS 38—(Continued).

SN 85-447,348. DISASTER INC., ST PETERSBURG, FL. FILED 10-14-2011.

john titor

THE MARK CONSISTS OF STANDARD CHARACTERS WITHOUT CLAIM TO ANY PARTICULAR FONT, STYLE, SIZE, OR COLOR.

THE NAME(S), PORTRAIT(S), AND/OR SIGNATURE(S) SHOWN IN THE MARK DOES NOT IDENTIFY A PARTICULAR LIVING INDIVIDUAL.

FOR TELECOMMUNICATION SERVICES, NAMELY, BROADCASTING SERVICES, NAMELY, AUDIO BROADCASTING, VIDEO BROADCASTING, BROADCASTING PROGRAMS VIA A GLOBAL COMPUTER NETWORK; COMMUNICATION SERVICES, NAMELY, STREAMING OF AUDIO MATERIAL ON THE INTERNET, STREAMING OF VIDEO MATERIAL ON THE INTERNET; ELECTRONIC TRANSMISSION OF MESSAGES AND DATA; WEBCASTING SERVICES; PROVIDING ON-LINE FORUMS FOR TRANSMISSION OF MESSAGES AMONG COMPUTER USERS, ALL IN THE FIELD OF TIME TRAVEL (U.S. CLS. 100, 101 AND 104).

MARK T. MULLEN, EXAMINING ATTORNEY

CLASS 38—(Continued).

SN 85-447,455. METROPCS WIRELESS, INC., RICHARDSON, TX. FILED 10-14-2011.

METROGLOBAL

THE MARK CONSISTS OF STANDARD CHARACTERS WITHOUT CLAIM TO ANY PARTICULAR FONT, STYLE, SIZE, OR COLOR.

OWNER OF U.S. REG. NOS. 2,803,097, 3,542,846 AND OTHERS.

FOR TELECOMMUNICATIONS SERVICES, NAMELY, WIRELESS TELEPHONY, WIRELESS BROADBAND COMMUNICATIONS SERVICES FOR THE TRANSMISSION OF VOICE, AND LONG DISTANCE TELEPHONE COMMUNICATION SERVICES (U.S. CLS. 100, 101 AND 104).

INGA ERVIN, EXAMINING ATTORNEY

SN 85-447,743. VSPORTO, LLC, MADISON, MS. FILED 10-14-2011.

SN 85-447,435. METROPCS WIRELESS, INC., RICHARDSON, TX. FILED 10-14-2011.

METROWORLD

THE MARK CONSISTS OF STANDARD CHARACTERS WITHOUT CLAIM TO ANY PARTICULAR FONT, STYLE, SIZE, OR COLOR.

OWNER OF U.S. REG. NOS. 2,803,097, 3,542,846 AND OTHERS.

FOR TELECOMMUNICATIONS SERVICES, NAMELY, WIRELESS TELEPHONY, WIRELESS BROADBAND COMMUNICATIONS SERVICES FOR THE TRANSMISSION OF VOICE, AND LONG DISTANCE TELEPHONE COMMUNICATION SERVICES (U.S. CLS. 100, 101 AND 104).

INGA ERVIN, EXAMINING ATTORNEY

VSPORTO

THE MARK CONSISTS OF STANDARD CHARACTERS WITHOUT CLAIM TO ANY PARTICULAR FONT, STYLE, SIZE, OR COLOR.

FOR BROADCASTING OF RADIO PROGRAMMES; BROADCASTING OF SPORTS RADIO PROGRAMS; INTERNET RADIO BROADCASTING SERVICES; INTERNET RADIO SERVICES, NAMELY, TRANSMISSION OF AUDIO MATERIAL VIA THE INTERNET; MOBILE RADIO TELEPHONE SERVICES; RADIO BROADCASTING; RADIO PROGRAM BROADCASTING (U.S. CLS. 100, 101 AND 104).

FIRST USE 9-27-2011; IN COMMERCE 9-27-2011.

KHANH LE, EXAMINING ATTORNEY

CLASS 38—(Continued).

SN 85-448,369. KRIETZMAN, MARK, PALOS VERDES, CA. FILED 10-15-2011.

YURDL

THE MARK CONSISTS OF STANDARD CHARACTERS WITHOUT CLAIM TO ANY PARTICULAR FONT, STYLE, SIZE, OR COLOR.

FOR AUDIO AND VIDEO BROADCASTING SERVICES OVER THE INTERNET OR OTHER COMMUNICATIONS NETWORK, NAMELY, UPLOADING, POSTING, SHOWING, DISPLAYING, TAGGING AND ELECTRONICALLY TRANSMITTING INFORMATION, AUDIO, AND VIDEO CLIPS; PROVIDING ACCESS TO INFORMATION, AUDIO, AND VIDEO VIA WEBSITES, CABLE TELEVISION, SATELLITE TELEVISION, GAMING SYSTEM, MEDIA BOXES, IP TV, OVER THE AIRWAVES, TELEPHONE LINES, INTERNET OR CABLE LINES (U.S. CLS. 100, 101 AND 104).

CHARLOTTE CORWIN, EXAMINING ATTORNEY

SN 85-448,643. METROPCS WIRELESS, INC., RICHARDSON, TX. FILED 10-17-2011.

METROBLOCK

THE MARK CONSISTS OF STANDARD CHARACTERS WITHOUT CLAIM TO ANY PARTICULAR FONT, STYLE, SIZE, OR COLOR.

OWNER OF U.S. REG. NOS. 2,803,097, 3,542,846 AND OTHERS.

FOR TELECOMMUNICATION SERVICES; TELECOMMUNICATION SERVICES, NAMELY, PROVIDING ADVANCED CALLING AND TEXTING FEATURES; TELECOMMUNICATION SERVICES, NAMELY INBOUND CALL AND TEXT BLOCKING (U.S. CLS. 100, 101 AND 104).

INGA ERVIN, EXAMINING ATTORNEY

SN 85-448,659. METROPCS WIRELESS, INC., RICHARDSON, TX. FILED 10-17-2011.

METROBLOCK-IT

THE MARK CONSISTS OF STANDARD CHARACTERS WITHOUT CLAIM TO ANY PARTICULAR FONT, STYLE, SIZE, OR COLOR.

OWNER OF U.S. REG. NOS. 2,803,097, 3,542,846 AND OTHERS.

FOR TELECOMMUNICATION SERVICES; TELECOMMUNICATION SERVICES, NAMELY, PROVIDING ADVANCED CALLING AND TEXTING FEATURES; TELECOMMUNICATION SERVICES, NAMELY INBOUND CALL AND TEXT BLOCKING (U.S. CLS. 100, 101 AND 104).

INGA ERVIN, EXAMINING ATTORNEY

CLASS 38—(Continued).

SN 85-448,950. GORDON, MICHAEL D., DERBY, KS. FILED 10-17-2011.

AAH

THE MARK CONSISTS OF STANDARD CHARACTERS WITHOUT CLAIM TO ANY PARTICULAR FONT, STYLE, SIZE, OR COLOR.

FOR VIDEO BROADCASTING AND TRANSMISSION SERVICES VIA THE INTERNET, FEATURING FILMS AND MOVIES; VIDEO BROADCASTING SERVICES OVER THE INTERNET OR OTHER COMMUNICATIONS NETWORK FEATURING THE UPLOADED, POSTED AND TAGGED VIDEOS OF OTHERS; VIDEO-ON-DEMAND TRANSMISSION SERVICES VIA THE INTERNET (U.S. CLS. 100, 101 AND 104).

MICHAEL WEBSTER, EXAMINING ATTORNEY

SN 85-452,902. METROPCS WIRELESS, INC., RICHARDSON, TX. FILED 10-21-2011.

METRONEWS

THE MARK CONSISTS OF STANDARD CHARACTERS WITHOUT CLAIM TO ANY PARTICULAR FONT, STYLE, SIZE, OR COLOR.

OWNER OF U.S. REG. NOS. 2,803,097, 3,542,846 AND OTHERS.

FOR TELECOMMUNICATIONS SERVICES, NAMELY, WIRELESS TELEPHONY AND WIRELESS BROADBAND COMMUNICATIONS SERVICES FOR THE TRANSMISSION OF VOICE, VIDEO, IMAGES, DATA AND INFORMATION; STREAMING OF DIGITAL MEDIA CONTENT FOR OTHERS VIA COMPUTER NETWORKS; PROVIDING E-MAIL SERVICES (U.S. CLS. 100, 101 AND 104).

INGA ERVIN, EXAMINING ATTORNEY

SN 85-454,668. WEST CORPORATION, OMAHA, NE. FILED 10-24-2011.

AlertFirst

THE MARK CONSISTS OF STANDARD CHARACTERS WITHOUT CLAIM TO ANY PARTICULAR FONT, STYLE, SIZE, OR COLOR.

FOR TELECOMMUNICATIONS SERVICES, NAMELY, PROVIDING NOTIFICATIONS VIA LANDLINE, CELLULAR PHONE, TEXT, FACSIMILE OR TEXT TELEPHONE (TTY) TO SELECT GROUPS OF INDIVIDUALS OR SPECIFIC GEOGRAPHIC AREAS (U.S. CLS. 100, 101 AND 104).

ANNE MADDEN, EXAMINING ATTORNEY

CLASS 38—(Continued).

SN 85-459,154. SUNSHINE STREAMING. LLC, NEW YORK CITY, NY. FILED 10-28-2011.



NO CLAIM IS MADE TO THE EXCLUSIVE RIGHT TO USE "FILM FESTIVAL" AND "REPLAY", APART FROM THE MARK AS SHOWN.

THE MARK CONSISTS OF A FILM STRIP GRAPHIC WITH A REWIND ICON. THE REWIND ICON IS REPRESENTED BY 2 LEFT POINTING ARROWS. THE FILM STRIP IS REPRESENTED BY A SQUARE SHAPE WITH SPROCKET HOLES ON THE UPPER AND LOWER EDGES. TO THE RIGHT THERE IS THE STYLIZED TEXT "FILM FESTIVAL REPLAY", WITH THE LETTER "F" BEING SHARED IN THE TERMS "FILM" AND "FESTIVAL".

FOR BROADCASTING SERVICES AND PROVISION OF TELECOMMUNICATION ACCESS TO VIDEO AND AUDIO CONTENT PROVIDED VIA A VIDEO-ON-DEMAND SERVICE VIA THE INTERNET; ELECTRONIC TRANSMISSION AND STREAMING OF DIGITAL MEDIA CONTENT FOR OTHERS VIA GLOBAL AND LOCAL COMPUTER NETWORKS; STREAMING OF AUDIO, VISUAL AND AUDIOVISUAL MATERIAL VIA A GLOBAL COMPUTER NETWORK (U.S. CLS. 100, 101 AND 104).

TEJBIR SINGH, EXAMINING ATTORNEY

CLASS 39—TRANSPORTATION AND STORAGE

SN 77-370,722. CITY CAB COMPANY OF ORLANDO, INC., ORLANDO, FL. FILED 1-14-2008.



NO CLAIM IS MADE TO THE EXCLUSIVE RIGHT TO USE "CAB", APART FROM THE MARK AS SHOWN.

THE COLOR(S) YELLOW, BLACK, AND WHITE IS/ARE CLAIMED AS A FEATURE OF THE MARK.

THE MARK CONSISTS OF A THREE-DIMENSIONAL CONFIGURATION OF A YELLOW VAN-STYLE VEHICLE WITH A YELLOW HORIZONTAL BAND ON A WHITE BACKGROUND AND THE WORDS "CHECKER CAB" AND A CHECKER DESIGN IN BLACK ON THE FRONT PASSENGER DOOR. THE MATTER SHOWN IN BROKEN LINES IS NOT PART OF THE MARK AND SERVES ONLY TO SHOW THE POSITION OR PLACEMENT OF THE MARK.

SEC. 2(F).

FOR TRANSPORTATION SERVICES, NAMELY, HIRED CAR TRANSPORT; PASSENGER TRANSPORT; TAXI TRANSPORT (U.S. CLS. 100 AND 105).

FIRST USE 0-0-1988; IN COMMERCE 0-0-1988.

VIVIAN MICZNIK FIRST, EXAMINING ATTORNEY

SN 79-101,324. CARS ON DEMAND LIMITED, UNITED KINGDOM, FILED 7-8-2011.

SN 85-523,224. PAYNE, TIMOTHY J., OCEANSIDE, CA. FILED 1-23-2012.

QRemembrance.com 3D QR Codes



OWNER OF INTERNATIONAL REGISTRATION 1087452 DATED 7-8-2011, EXPIRES 7-8-2021.

NO CLAIM IS MADE TO THE EXCLUSIVE RIGHT TO USE "CARS ON DEMAND", APART FROM THE MARK AS SHOWN.

THE COLOR(S) ORANGE, BLACK, WHITE AND GREY IS/ARE CLAIMED AS A FEATURE OF THE MARK.

THE MARK CONSISTS OF A BLACK RECTANGLE CARRIER WITH THE WORDS "CARS ON DEMAND" WITH THE WORD "CARS" APPEARING IN WHITE, THE WORD "ON" APPEARING IN GREY, AND THE WORD "DEMAND" IN ORANGE. TO THE RIGHT OF THE WORDING APPEARS A STYLIZED HIGHWAY SHADED IN GREY, ORANGE AND WHITE.

FOR VEHICLE RENTAL AND LEASING (U.S. CLS. 100 AND 105).

JACLYN KIDWELL WALKER, EXAMINING ATTORNEY

THE MARK CONSISTS OF STANDARD CHARACTERS WITHOUT CLAIM TO ANY PARTICULAR FONT, STYLE, SIZE, OR COLOR.

NO CLAIM IS MADE TO THE EXCLUSIVE RIGHT TO USE "3D QR CODES", APART FROM THE MARK AS SHOWN.

FOR COMPUTER TRANSMISSION OF INFORMATION ACCESSED VIA A CODE OR A TERMINAL (U.S. CLS. 100, 101 AND 104).

COLLEEN KEARNEY, EXAMINING ATTORNEY

CLASS 39—(Continued).

SN 85-114,182. TRANSCORE COMMERCIAL SERVICES, LLC, BEAVERTON, OR. FILED 8-24-2010.

TRANSCORE TRENDLINES

THE MARK CONSISTS OF STANDARD CHARACTERS WITHOUT CLAIM TO ANY PARTICULAR FONT, STYLE, SIZE, OR COLOR.

NO CLAIM IS MADE TO THE EXCLUSIVE RIGHT TO USE "TRENDLINES", APART FROM THE MARK AS SHOWN.

FOR PROVIDING A WEBSITE FEATURING NEWS AND DATA INFORMATION IN THE FREIGHT TRANSPORTATION INDUSTRY (U.S. CLS. 100 AND 105).

FIRST USE 9-15-2009; IN COMMERCE 9-15-2009.
DEIRDRE ROBERTSON, EXAMINING ATTORNEY

SN 85-117,244. MIDWAY ARMS, INC., COLOMBIA, MO. FILED 8-27-2010.

NITRO EXPRESS SHIPPING

THE MARK CONSISTS OF STANDARD CHARACTERS WITHOUT CLAIM TO ANY PARTICULAR FONT, STYLE, SIZE, OR COLOR.

NO CLAIM IS MADE TO THE EXCLUSIVE RIGHT TO USE "EXPRESS SHIPPING", APART FROM THE MARK AS SHOWN.

FOR SHIPPING OF GUNS, HUNTING PRODUCTS, SHOOTING SPORTS PRODUCTS EXCLUDING PISTONS, APPAREL AND FOOTWEAR (U.S. CLS. 100 AND 105).

CHRISIE B. KING, EXAMINING ATTORNEY

SN 85-198,757. EKOVENTURE, INC., AKA ZOZI, SAN FRANCISCO, CA. FILED 12-15-2010.

zozi guru

THE MARK CONSISTS OF STANDARD CHARACTERS WITHOUT CLAIM TO ANY PARTICULAR FONT, STYLE, SIZE, OR COLOR.

THE WORDING "ZOZI" HAS NO MEANING IN A FOREIGN LANGUAGE.

FOR ORGANIZATION, BOOKING AND ARRANGEMENT OF ADVENTURE EXCURSIONS, DAY TRIPS, AND SIGHTSEEING TOURS ACCOMPANIED BY PROFESSIONAL ATHLETES AND CELEBRITIES; TRAVEL PACKAGES IN THE NATURE OF ORGANIZATION OF TRAVEL AND ARRANGING TRAVEL TOURS ACCOMPANIED BY PROFESSIONAL ATHLETES AND CELEBRITIES (U.S. CLS. 100 AND 105).

FIRST USE 1-24-2012; IN COMMERCE 1-24-2012.
NELSON SNYDER, EXAMINING ATTORNEY

CLASS 39—(Continued).

SN 85-233,448. AMERICAN EXPRESS MARKETING & DEVELOPMENT CORP., NEW YORK, NY. FILED 2-3-2011.



NO CLAIM IS MADE TO THE EXCLUSIVE RIGHT TO USE "TRAVEL", APART FROM THE MARK AS SHOWN.

THE MARK CONSISTS OF THE TERM "SCENESTER" AND SUNGLASSES WITHIN A BADGE. THE BACKGROUND OF THE BADGE IS COVERED IN LETTERS SPELLING "AMERICAN EXPRESS TRAVEL".

FOR ARRANGING TRAVEL TOURS, NAMELY, CUSTOMIZED MYSTERY TRIP BASED ON RESPONSES TO A QUIZ; CUSTOMIZED MYSTERY TRIP BASED ON RESPONSES TO A QUIZ, NAMELY, MAKING RESERVATIONS AND BOOKINGS FOR TRANSPORTATION (U.S. CLS. 100 AND 105).

KYLE PEETE, EXAMINING ATTORNEY

SN 85-252,979. PARKLAND TRAVEL, LTD., DBA SPLASH VACATION AND CRUISE, HALES CORNERS, WI. FILED 2-28-2011.

Splash Vacation and Cruise

THE MARK CONSISTS OF STANDARD CHARACTERS WITHOUT CLAIM TO ANY PARTICULAR FONT, STYLE, SIZE, OR COLOR.

NO CLAIM IS MADE TO THE EXCLUSIVE RIGHT TO USE "VACATION AND CRUISE", APART FROM THE MARK AS SHOWN.

FOR BOOKING OF SEATS FOR TRAVEL; ESCORTING OF TRAVELERS; TRANSPORTATION RESERVATION SERVICES; TRAVEL AND TOUR TICKET RESERVATION SERVICES; RESERVATION AND BOOKING SEATS FOR TRAVEL; TRANSPORT OF TRAVELLERS, PROFESSIONAL TRAVEL CONSULTATION AND PLANNING OF VACATIONS AND CRUISES FOR SINGLES, COUPLES, FAMILIES AND GROUPS, NAMELY, ARRANGING FOR TRAVEL VISAS, PASSPORTS AND TRAVEL DOCUMENTS FOR PERSONS TRAVELING ABROAD, COORDINATING TRAVEL ARRANGEMENTS FOR INDIVIDUALS AND FOR GROUPS, ORGANIZATION OF TRAVEL, PROVISION OF TRAVEL INFORMATION, TRAVEL ROUT PLANNING, AND TRAVEL, EXCURSION AND CRUISE ARRANGEMENT ALL DESTINATIONS THROUGHOUT THE WORLD (U.S. CLS. 100 AND 105).

FIRST USE 2-11-2011; IN COMMERCE 2-11-2011.
LEIGH CAROLINE CASE, EXAMINING ATTORNEY

CLASS 39—(Continued).

SN 85-311,442. MEDQUICK ADVANTAGE, LLC, FRIDLEY, MN. FILED S.R. 5-3-2011; AM. P.R. 1-31-2012.

MEDQUICK ADVANTAGE

THE MARK CONSISTS OF STANDARD CHARACTERS WITHOUT CLAIM TO ANY PARTICULAR FONT, STYLE, SIZE, OR COLOR.

FOR COURIER SERVICES; MEDICAL TRANSPORT SERVICES (U.S. CLS. 100 AND 105).

FIRST USE 11-8-2010; IN COMMERCE 11-8-2010.

ROBERT C. CLARK JR., EXAMINING ATTORNEY

SN 85-339,645. ASTRA TECH AB, MÖLNDAL, SWEDEN, FILED 6-7-2011.



NO CLAIM IS MADE TO THE EXCLUSIVE RIGHT TO USE "HOME DELIVERY", APART FROM THE MARK AS SHOWN.

THE COLOR(S) RED AND BLUE IS/ARE CLAIMED AS A FEATURE OF THE MARK.

THE MARK CONSISTS OF THE WORDING "SELECT US LOFRIC HOME DELIVERY" WITH A STYLIZED DROP AND RIPPLE DESIGN TO THE RIGHT OF THE WORDING. THE WORDS "SELECT" AND "LOFRIC HOME DELIVERY" AND THE DROP ARE ALL IN BLUE. THE TOP OF THE "U" IN "US" IS IN BLUE, WHILE THE BOTTOM OF THE "U" IS IN RED, AND THE RIPPLES AROUND THE DROP ARE ALSO IN RED.

FOR HOME DELIVERY SERVICES FOR MEDICAL DEVICES (U.S. CLS. 100 AND 105).

INGA ERVIN, EXAMINING ATTORNEY

SN 85-368,834. DALLAS AREA RAPID TRANSIT, DALLAS, TX. FILED 7-12-2011.

On the go In the know

THE MARK CONSISTS OF STANDARD CHARACTERS WITHOUT CLAIM TO ANY PARTICULAR FONT, STYLE, SIZE, OR COLOR.

FOR PROVISION OF ONLINE TRAVEL INFORMATION, NAMELY, PROVIDING DEPARTURE AND ARRIVAL TIMES AND ROUTES FOR MASS TRANSIT FOR THE GENERAL PUBLIC (U.S. CLS. 100 AND 105).

RICHARD WHITE, EXAMINING ATTORNEY

CLASS 39—(Continued).

SN 85-392,893. GREATER ORLANDO AVIATION AUTHORITY, ORLANDO, FL. FILED 8-9-2011.

The Orlando Experience

THE MARK CONSISTS OF STANDARD CHARACTERS WITHOUT CLAIM TO ANY PARTICULAR FONT, STYLE, SIZE, OR COLOR.

NO CLAIM IS MADE TO THE EXCLUSIVE RIGHT TO USE "ORLANDO", APART FROM THE MARK AS SHOWN.

FOR AIRPORT SERVICES (U.S. CLS. 100 AND 105).

FIRST USE 1-21-1998; IN COMMERCE 1-21-1998.

MICHAEL WEBSTER, EXAMINING ATTORNEY

SN 85-401,496. SAN DIEGO SPEED BOAT ADVENTURES INC., SAN DIEGO, CA. FILED 8-18-2011.



OWNER OF U.S. REG. NO. 3,936,067.

NO CLAIM IS MADE TO THE EXCLUSIVE RIGHT TO USE "SPEED BOAT ADVENTURES", APART FROM THE MARK AS SHOWN.

THE MARK CONSISTS OF THE WORDS "SPEED BOAT" IN STYLIZED LETTERING DIRECTLY ABOVE THE WORD "ADVENTURES" ALSO WRITTEN IN STYLIZED LETTERING WHICH IS SLIGHTLY ARCHED; BELOW THE WORD "ADVENTURES" IS A DRAWING OF A SPEED BOAT SHOWN WITH A WAKE OF WATER TRAILING BEHIND THE BOAT WHICH ARCHES OUT TO THE RIGHT OF THE DESIGN AND ENDS ABOVE THE WORDS "SPEED BOAT"; ALSO ABOVE THE WORDS "SPEED BOAT" AND POSITIONED BEHIND THE ARCHED WAKE IS A MULTI-POINTED STAR-LIKE IMAGE, BACKED BY A SOLID HALF CIRCLE.

FOR CONDUCTING BOAT CHARTERS; CONDUCTING SIGHTSEEING TOURS BY BOAT; RENTAL OF BOATS (U.S. CLS. 100 AND 105).

FIRST USE 1-15-2010; IN COMMERCE 1-15-2010.

KATHLEEN KOLACZ, EXAMINING ATTORNEY

CLASS 39—(Continued).

SN 85-403,961. SHERPA CLINICAL PACKAGING, LLC, DBA SHERPA CLINICAL PACKAGING, LLC, SAN DIEGO, CA. FILED 8-22-2011.



NO CLAIM IS MADE TO THE EXCLUSIVE RIGHT TO USE "CLINICAL PACKAGING", APART FROM THE MARK AS SHOWN.

THE COLOR(S) WHITE, BLACK AND BLUE IS/ARE CLAIMED AS A FEATURE OF THE MARK.

THE MARK CONSISTS OF THE WORDS "SHERPA CLINICAL PACKAGING" IN BLACK ON A WHITE BACKGROUND WITH BLUE MOUNTAINTOPS.

FOR MERCHANDISE PACKAGING FOR OTHERS; PACKAGING AND PARCELLING OF GOODS FOR TRANSPORT PURPOSES, NAMELY, THE PACKING OF GOODS USING SUSTAINABLE OR BIODEGRADABLE PACKAGING AND SHIPPING MATERIALS; PACKAGING ARTICLES FOR TRANSPORTATION; PACKAGING ARTICLES TO THE ORDER AND SPECIFICATION OF OTHERS; SUPPLY CHAIN LOGISTICS AND REVERSE LOGISTICS SERVICES, NAMELY, STORAGE, TRANSPORTATION AND DELIVERY OF DOCUMENTS, PACKAGES, RAW MATERIALS, AND OTHER FREIGHT FOR OTHERS BY AIR, RAIL, SHIP OR TRUCK; WAREHOUSING SERVICES, NAMELY, STORAGE, DISTRIBUTION, PICK-UP, AND PACKING FOR SHIPMENT OF DOCUMENTS, PACKAGES, RAW MATERIALS, AND OTHER FREIGHT FOR OTHERS (U.S. CLS. 100 AND 105).

FIRST USE 11-17-2010; IN COMMERCE 11-17-2010.
ERNEST SHOSHO, EXAMINING ATTORNEY

SN 85-411,713. ALASKA AIRLINES, INC., SEATTLE, WA. FILED 8-31-2011.

FLYINGSOCIAL

THE MARK CONSISTS OF STANDARD CHARACTERS WITHOUT CLAIM TO ANY PARTICULAR FONT, STYLE, SIZE, OR COLOR.

FOR AIR TRANSPORTATION SERVICES (U.S. CLS. 100 AND 105).

FIRST USE 8-31-2011; IN COMMERCE 8-31-2011.
CARRIE GENOVESE, EXAMINING ATTORNEY

CLASS 39—(Continued).

SN 85-415,184. GROUPIST, INC., NEW YORK, NY. FILED 9-6-2011.

EUROPEAN GATEWAYS

THE MARK CONSISTS OF STANDARD CHARACTERS WITHOUT CLAIM TO ANY PARTICULAR FONT, STYLE, SIZE, OR COLOR.

NO CLAIM IS MADE TO THE EXCLUSIVE RIGHT TO USE "EUROPEAN", APART FROM THE MARK AS SHOWN.

FOR TRAVEL AGENCY SERVICES, NAMELY, MAKING RESERVATIONS AND BOOKINGS FOR TRANSPORTATION (U.S. CLS. 100 AND 105).

TOBY BULLOFF, EXAMINING ATTORNEY

SN 85-431,457. CHRISTOPHER W REAMER, DBA GREY-WATER GURU, PETALUMA, CA. FILED 9-26-2011.

Greywater Guru

THE MARK CONSISTS OF STANDARD CHARACTERS WITHOUT CLAIM TO ANY PARTICULAR FONT, STYLE, SIZE, OR COLOR.

NO CLAIM IS MADE TO THE EXCLUSIVE RIGHT TO USE "GREYWATER", APART FROM THE MARK AS SHOWN.

FOR RECYCLED WATER DISTRIBUTION SERVICES FOR OTHERS (U.S. CLS. 100 AND 105).

FIRST USE 1-15-2011; IN COMMERCE 6-1-2011.
ROSELLE HERRERA, EXAMINING ATTORNEY

SN 85-433,534. AEROTURBINE, INC., MIAMI, FL. FILED 9-27-2011.

OWNER OF U.S. REG. NOS. 2,260,554 AND 3,138,938.

THE MARK CONSISTS OF "AEROTURBINE" WITH SWIRL DESIGN OVER "AERO".

SEC. 2(F) AS TO "AEROTURBINE".

FOR RENTAL AND LEASING OF AIRCRAFT, AIRCRAFT ENGINES, AND PARTS THEREOF (U.S. CLS. 100 AND 105).

DAVID ELTON, EXAMINING ATTORNEY

CLASS 39—(Continued).

SN 85-438,186. COWTOWN BUS CHARTERS, INC., FORT WORTH, TX. FILED 10-3-2011.

COWTOWN BUS CHARTERS, INC.

NO CLAIM IS MADE TO THE EXCLUSIVE RIGHT TO USE "BUS CHARTERS, INC.", APART FROM THE MARK AS SHOWN.

THE MARK CONSISTS OF THE WORDS "COWTOWN BUS CHARTERS, INC." IN STYLIZED FONT.

SEC. 2(F).
FOR PASSENGER TRANSPORT; TRANSPORTATION OF PASSENGERS AND/OR GOODS BY BUS (U.S. CLS. 100 AND 105).

FIRST USE 10-0-1990; IN COMMERCE 10-0-1990.
WILLIAM JACKSON, EXAMINING ATTORNEY

SN 85-439,218. COWTOWN BUS CHARTERS, INC., FORT WORTH, TX. FILED 10-4-2011.

COWTOWN  CHARTERS

NO CLAIM IS MADE TO THE EXCLUSIVE RIGHT TO USE "CHARTERS", APART FROM THE MARK AS SHOWN.

THE MARK CONSISTS OF THE STYLIZED WORDS "COWTOWN CHARTERS" SEPARATED BY A DRAWING OF A COWBOY BOOT AND SPUR.

SEC. 2(F).
FOR PASSENGER TRANSPORT; TRANSPORTATION OF PASSENGERS AND/OR GOODS BY BUS (U.S. CLS. 100 AND 105).

FIRST USE 10-0-1990; IN COMMERCE 10-0-1990.
WILLIAM JACKSON, EXAMINING ATTORNEY

SN 85-440,779. BRAMMO, INC., ASHLAND, OR. FILED 10-6-2011.

BRAMMOPARX

THE MARK CONSISTS OF STANDARD CHARACTERS WITHOUT CLAIM TO ANY PARTICULAR FONT, STYLE, SIZE, OR COLOR.

OWNER OF U.S. REG. NO. 3,831,681.
FOR RENTAL OF VEHICLES (U.S. CLS. 100 AND 105).
HELENE LIWINSKI, EXAMINING ATTORNEY

CLASS 39—(Continued).

SN 85-442,266. ASTA PARKING, FORT LAUDERDALE, FL. FILED 10-7-2011.

 **ASTA PARKING**

NO CLAIM IS MADE TO THE EXCLUSIVE RIGHT TO USE "PARKING", APART FROM THE MARK AS SHOWN.

THE MARK CONSISTS OF THE LETTERS "AP", BLENDED AS ONE INSIDE A CIRCLE THAT IS OPEN AT THE BOTTOM, AND THE WORDS "ASTA PARKING" TO THE RIGHT OF THE CIRCLE WITH THE WORD "PARKING" BELOW THE WORD "ASTA".

FOR PARKING LOT SERVICES (U.S. CLS. 100 AND 105).

TINA MAI, EXAMINING ATTORNEY

SN 85-442,805. CALIFORNIA PASSPORT, LLC, MORGAN HILL, CA. FILED 10-8-2011.

California Passport

THE MARK CONSISTS OF STANDARD CHARACTERS WITHOUT CLAIM TO ANY PARTICULAR FONT, STYLE, SIZE, OR COLOR.

NO CLAIM IS MADE TO THE EXCLUSIVE RIGHT TO USE "CALIFORNIA", APART FROM THE MARK AS SHOWN.

FOR ARRANGING EXCURSIONS FOR TOURISTS; ARRANGING OF TOURS; ARRANGING OF TOURS AND CRUISES; ARRANGING TRAVEL TOURS; ARRANGING, ORGANIZING, AND CONDUCTING CYCLING TOURS AND TRIPS; BUS TRANSPORT; CAR TRANSPORT; CONDUCTING SIGHTSEEING TOURS BY BUS, MINIBUS, MINIVAN, LIMOUSINE, OR CAR; CONDUCTING SIGHTSEEING TOURS FOR OTHERS; HIRED CAR TRANSPORT; MOVING VAN TRANSPORT; ON-LINE TRANSPORTATION RESERVATION AND TRAVEL TICKET RESERVATION SERVICES; ONLINE TRANSPORTATION RESERVATION SERVICES; ORGANISATION OF SIGHTSEEING TOURS; ORGANIZATION OF EXCURSIONS, SIGHTSEEING TOURS, HOLIDAYS, TOURS AND TRAVEL; ORGANIZATION, BOOKING AND ARRANGEMENT OF EXCURSIONS, DAY TRIPS AND SIGHTSEEING TOURS; ORGANIZING TRAVEL FOR OTHERS; PASSENGER TRANSPORT; PERSONAL TOUR GUIDE SERVICES; TOUR CONDUCTING; TOUR CONDUCTING OR ESCORTING; TOUR GUIDE SERVICES; TOUR OPERATING; TOUR OPERATING AND ORGANISING; TOUR ORGANISING; TRANSPORT BY

CLASS 39—(Continued).

BUS, MINIBUS, MINIVAN, LIMOUSINE, OR CAR; TRANSPORT OF PASSENGERS; TRANSPORT OF PERSONS; TRANSPORT OF TRAVELLERS; TRANSPORT OF PEOPLE AND BAGGAGE BY BUS, MINIBUS, MINIVAN, LIMOUSINE, OR CAR; TRANSPORT SERVICES, NAMELY, LOCAL, INTERSTATE AND INTERNATIONAL MOVING SERVICES; TRANSPORTATION INFORMATION; TRANSPORTATION OF PASSENGERS AND PASSENGERS' LUGGAGE; TRANSPORTATION OF PASSENGERS AND/OR GOODS BY BUS, MINIBUS, MINIVAN, LIMOUSINE, OR CAR; TRANSPORTATION RESERVATION SERVICES; TRANSPORTATION SERVICES, NAMELY, PROVIDING SHUTTLE SERVICES BY BUS, MINIBUS, MINIVAN, LIMOUSINE, OR CAR; TRANSPORTATION SERVICES, NAMELY, PROVIDING SHUTTLE SERVICES FOR GOLFERS; TRAVEL AGENCY SERVICES, NAMELY, MAKING RESERVATIONS AND BOOKINGS FOR TRANSPORTATION; TRAVEL AND TOUR INFORMATION SERVICE; TRAVEL AND TOUR TICKET RESERVATION SERVICE (U.S. CLS. 100 AND 105).

FIRST USE 4-1-2008; IN COMMERCE 8-1-2011.

JACQUELINE A. LAVINE, EXAMINING ATTORNEY

SN 85-446,354. OTOOLE, MICHAEL, ROCKAWAY PARK, NY. FILED 10-13-2011.

when you're shot, we're
not.

THE MARK CONSISTS OF STANDARD CHARACTERS WITHOUT CLAIM TO ANY PARTICULAR FONT, STYLE, SIZE, OR COLOR.

FOR TAXI TRANSPORT (U.S. CLS. 100 AND 105).
DOMINIC FATHY, EXAMINING ATTORNEY

SN 85-447,280. CHESAPEAKE UTILITIES CORPORATION, DOVER, DE. FILED 10-13-2011.



OWNER OF U.S. REG. NO. 4,077,951.

NO CLAIM IS MADE TO THE EXCLUSIVE RIGHT TO USE "CHESAPEAKE UTILITIES SERVICES", APART FROM THE MARK AS SHOWN.

THE MARK CONSISTS OF A STYLIZED DOMINANT WORD "CHESAPEAKE" WITH A FLAME APPEARING ABOVE THE FIRST-APPEARING LETTER "A"; THE WORD "CHESAPEAKE" APPEARS ABOVE THE WORD "UTILITIES"; THE WORD "UTILITIES" APPEARS ABOVE THE WORD "SERVICES".

FOR PUBLIC UTILITY SERVICES; PUBLIC UTILITY SERVICES IN THE NATURE OF ELECTRICITY DISTRIBUTION; PUBLIC UTILITY SERVICES IN THE NATURE OF NATURAL GAS DISTRIBUTION (U.S. CLS. 100 AND 105).

B. PARADEWELAI, EXAMINING ATTORNEY

CLASS 39—(Continued).

SN 85-447,442. ATLANTA PEACH MOVERS, INC., DORAVILLE, GA. FILED 10-14-2011.

ATLANTA PEACH MOVERS

THE MARK CONSISTS OF STANDARD CHARACTERS WITHOUT CLAIM TO ANY PARTICULAR FONT, STYLE, SIZE, OR COLOR.

OWNER OF U.S. REG. NO. 3,382,375.

NO CLAIM IS MADE TO THE EXCLUSIVE RIGHT TO USE "ATLANTA" OR "MOVERS", APART FROM THE MARK AS SHOWN.

FOR MOVING AND STORAGE OF FURNITURE, MISCELLANEOUS HOUSEHOLD ITEMS, AND MISCELLANEOUS BUSINESS ITEMS; PACKING ARTICLES FOR TRANSPORTATION; RENTAL OF MOVING EQUIPMENT, NAMELY, PADS, STRAPS, HITCHES, DOLLIES, BOXES, CARRIERS, AND HAND TRUCKS; RENTAL OF TRUCKS; TRANSPORT OF GOODS AND FURNITURE OF OTHERS BY TRUCK, VAN, OR AUTOMOBILE (U.S. CLS. 100 AND 105).

FIRST USE 9-1-1998; IN COMMERCE 9-1-1998.

THOMAS MANOR, EXAMINING ATTORNEY

SN 85-447,732. AAR CORP., WOOD DALE, IL. FILED 10-14-2011.

AAR

THE MARK CONSISTS OF STANDARD CHARACTERS WITHOUT CLAIM TO ANY PARTICULAR FONT, STYLE, SIZE, OR COLOR.

OWNER OF U.S. REG. NOS. 2,280,849, 2,389,476 AND 2,475,025.

FOR TRANSPORT OF PASSENGERS AND GOODS (U.S. CLS. 100 AND 105).

FIRST USE 1-3-2011; IN COMMERCE 1-3-2011.

ELLEN B. AWRICH, EXAMINING ATTORNEY

SN 85-448,138. MCS CARGO SYSTEMS, INC., DBA EA LOGISTICS, WOOD DALE, IL. FILED 10-14-2011.

EA LOGISTICS

THE MARK CONSISTS OF STANDARD CHARACTERS WITHOUT CLAIM TO ANY PARTICULAR FONT, STYLE, SIZE, OR COLOR.

OWNER OF U.S. REG. NOS. 3,210,668 AND 3,479,823.

NO CLAIM IS MADE TO THE EXCLUSIVE RIGHT TO USE "LOGISTICS", APART FROM THE MARK AS SHOWN.

FOR FREIGHT TRANSPORTATION BY MOTOR VEHICLES, AUTOMOBILES, TRUCKS, RAILWAYS, SHIPS AND PLANES; WAREHOUSING SERVICES (U.S. CLS. 100 AND 105).

FIRST USE 6-2-2005; IN COMMERCE 6-2-2005.

APRIL HESIK, EXAMINING ATTORNEY

CLASS 39—(Continued).

SN 85-448,167. MCS CARGO SYSTEMS, INC., DBA EA LOGISTICS, WOOD DALE, IL. FILED 10-14-2011.



OWNER OF U.S. REG. NOS. 3,210,668 AND 3,479,823.
NO CLAIM IS MADE TO THE EXCLUSIVE RIGHT TO USE "LOGISTICS", APART FROM THE MARK AS SHOWN.
THE MARK CONSISTS OF THE WORDING "EA" WITH THE WORD "LOGISTICS" STAGGERED UNDERNEATH.
FOR FREIGHT TRANSPORTATION BY MOTOR VEHICLES, AUTOMOBILES, TRUCKS, RAILWAYS, SHIPS AND PLANES; WAREHOUSING SERVICES (U.S. CLS. 100 AND 105).
FIRST USE 9-2-2011; IN COMMERCE 9-2-2011.
APRIL HESIK, EXAMINING ATTORNEY

SN 85-448,355. SLOW GLOBE TRAVEL LLC, COLLEGE PARK, MD. FILED 10-15-2011.



THE COLOR(S) BLUE, GREEN, BROWN, BLACK IS/ARE CLAIMED AS A FEATURE OF THE MARK.
THE MARK CONSISTS OF A STYLIZED BROWN SNAIL GRAPHIC IMAGE WITH A STYLIZED BLUE, GREEN AND BLACK WORLD GLOBE MAP AS THE SHELL.
FOR ARRANGING AND COORDINATING TRAVEL ARRANGEMENTS FOR INDIVIDUALS AND GROUPS, NAMELY, DESTINATIONS STAYS, HONEYMOONS, FAMILY VACATIONS, AND DESTINATION WEDDINGS; ARRANGING TRAVEL TOURS; COORDINATING TRAVEL ARRANGEMENTS FOR INDIVIDUALS AND FOR GROUPS; ESCORTING TRAVELLERS; ORGANISATION OF TRAVEL; ORGANIZATION OF EXCURSIONS, SIGHTSEEING TOURS, HOLIDAYS, TOURS AND TRAVEL; PROVIDING A WEBSITE FEATURING INFORMATION ON TRAVEL (U.S. CLS. 100 AND 105).
FIRST USE 2-1-2010; IN COMMERCE 5-1-2011.
PRISCILLA MILTON, EXAMINING ATTORNEY

CLASS 39—(Continued).

SN 85-448,864. GATE 1 LTD, DBA GATE 1 TRAVEL, FT. WASHINGTON, PA. FILED 10-17-2011.

Gate 1 Travel

THE MARK CONSISTS OF STANDARD CHARACTERS WITHOUT CLAIM TO ANY PARTICULAR FONT, STYLE, SIZE, OR COLOR.
NO CLAIM IS MADE TO THE EXCLUSIVE RIGHT TO USE "TRAVEL", APART FROM THE MARK AS SHOWN.
FOR ARRANGING AND COORDINATING TRAVEL ARRANGEMENTS FOR INDIVIDUALS AND GROUPS, NAMELY, DESTINATIONS STAYS, HONEYMOONS, FAMILY VACATIONS, AND DESTINATION WEDDINGS; ARRANGING TRAVEL TOURS; BOOKING OF SEATS FOR TRAVEL; ESCORTING TRAVELLERS; RESERVATION AND BOOKING OF SEATS FOR TRAVEL (U.S. CLS. 100 AND 105).
FIRST USE 2-23-1993; IN COMMERCE 2-23-1993.
EVELYN BRADLEY, EXAMINING ATTORNEY

SN 85-448,870. ALABAMA GAS CORPORATION, BIRMINGHAM, AL. FILED 10-17-2011.

WE'RE THE GOOD HEAT

THE MARK CONSISTS OF STANDARD CHARACTERS WITHOUT CLAIM TO ANY PARTICULAR FONT, STYLE, SIZE, OR COLOR.
FOR PUBLIC UTILITY SERVICES IN THE NATURE OF NATURAL GAS DISTRIBUTION (U.S. CLS. 100 AND 105).
FIRST USE 10-10-2011; IN COMMERCE 10-10-2011.
THEODORE MCBRIDE, EXAMINING ATTORNEY

SN 85-449,522. MIDWEST TAPE, LLC, HOLLAND, OH. FILED 10-18-2011.

HOOPLA

THE MARK CONSISTS OF STANDARD CHARACTERS WITHOUT CLAIM TO ANY PARTICULAR FONT, STYLE, SIZE, OR COLOR.
FOR DISTRIBUTION SERVICES, NAMELY, DELIVERY OF AUDIOVISUAL AND AUDIO RECORDINGS (U.S. CLS. 100 AND 105).
CURTIS FRENCH, EXAMINING ATTORNEY

CLASS 39—(Continued).

SN 85-449,567. CARTER-TRUSSELL, MARY L., ST. PETERSBURG, FL. FILED 10-18-2011.

FIRST STEP ANIMAL AMBULANCE EXPRESS

THE MARK CONSISTS OF STANDARD CHARACTERS WITHOUT CLAIM TO ANY PARTICULAR FONT, STYLE, SIZE, OR COLOR.

NO CLAIM IS MADE TO THE EXCLUSIVE RIGHT TO USE "ANIMAL AMBULANCE EXPRESS", APART FROM THE MARK AS SHOWN.

FOR ANIMAL TRANSPORTATION SERVICES; ANIMAL AMBULANCE TRANSPORT SERVICES (U.S. CLS. 100 AND 105).

CHRISTOPHER LAW, EXAMINING ATTORNEY

SN 85-449,805. AGXIT, LLC, JEFFERSONVILLE, OH. FILED 10-18-2011.

AGXIT

THE MARK CONSISTS OF STANDARD CHARACTERS WITHOUT CLAIM TO ANY PARTICULAR FONT, STYLE, SIZE, OR COLOR.

FOR GLOBAL TRANSPORTATION OF FREIGHT FOR OTHERS BY ALL AVAILABLE MEANS (U.S. CLS. 100 AND 105).

GEORGE LORENZO, EXAMINING ATTORNEY

CLASS 39—(Continued).

SN 85-450,364. POWER FREIGHT SYSTEMS, INC., NEWARK, CA. FILED 10-18-2011.

JAVELIN LOGISTICS

THE MARK CONSISTS OF STANDARD CHARACTERS WITHOUT CLAIM TO ANY PARTICULAR FONT, STYLE, SIZE, OR COLOR.

NO CLAIM IS MADE TO THE EXCLUSIVE RIGHT TO USE "LOGISTICS", APART FROM THE MARK AS SHOWN.

FOR FREIGHT FORWARDING; FREIGHT LOADING SERVICES; TRANSPORTATION OF GOODS BY AIR, SHIP, RAIL, AND TRUCK; GLOBAL AND DOMESTIC TRANSPORTATION OF FREIGHT FOR OTHERS BY ALL AVAILABLE MEANS; LOCAL AND REGIONAL CARTAGE SERVICES, NAMELY, TRANSPORTING MATERIAL BY TRUCK FOR OTHERS; TRANSPORTATION AND DELIVERY OF GOODS; WAREHOUSING SERVICES, NAMELY, STORAGE, DISTRIBUTION, PICK-UP, AND PACKING FOR SHIPMENT OF DOCUMENTS, PACKAGES, RAW MATERIALS, INDUSTRIAL AND COMMERCIAL GOODS, AND OTHER FREIGHT FOR OTHERS; DELIVERY OF DOCUMENTS, PACKAGES, AND INDUSTRIAL AND COMMERCIAL GOODS, AND OTHER FREIGHT FOR OTHERS; AIR FREIGHT SHIPPING SERVICES; FREIGHT TRANSPORTATION CONSULTATION IN THE FIELD OF FREIGHT TRANSPORTATION BY TRUCK, RAIL, AIR, AND OCEAN; SUPPLY CHAIN LOGISTICS AND REVERSE LOGISTICS SERVICES, NAMELY, STORAGE, TRANSPORTATION AND DELIVERY OF DOCUMENTS, PACKAGES, RAW MATERIALS, AND OTHER FREIGHT FOR OTHERS BY AIR, RAIL, SHIP OR TRUCK (U.S. CLS. 100 AND 105).

LAURIE MAYES, EXAMINING ATTORNEY

SN 85-459,394. ENTERPRISE HOLDINGS, INC., ST. LOUIS, MO. FILED 10-28-2011.

PUMP LESS

THE MARK CONSISTS OF STANDARD CHARACTERS WITHOUT CLAIM TO ANY PARTICULAR FONT, STYLE, SIZE, OR COLOR.

FOR VEHICLE RENTAL AND LEASING SERVICES, AND RESERVATION SERVICES FOR THE RENTAL AND LEASING OF VEHICLES (U.S. CLS. 100 AND 105).

ESTHER A. BORSUK, EXAMINING ATTORNEY

CLASS 39—(Continued).

SN 85-465,064. ALABAMA GAS CORPORATION, BIRMINGHAM, AL. FILED 11-4-2011.

ALAGASCO

THE MARK CONSISTS OF STANDARD CHARACTERS WITHOUT CLAIM TO ANY PARTICULAR FONT, STYLE, SIZE, OR COLOR.

FOR PUBLIC UTILITY SERVICES IN THE NATURE OF NATURAL GAS DISTRIBUTION (U.S. CLS. 100 AND 105).

FIRST USE 10-1-1979; IN COMMERCE 10-1-1979.
THEODORE MCBRIDE, EXAMINING ATTORNEY

SN 85-466,865. ENTERPRISE HOLDINGS, INC., ST. LOUIS, MO. FILED 11-8-2011.

PUMP LESS, OR PUMPLESS.

THE MARK CONSISTS OF STANDARD CHARACTERS WITHOUT CLAIM TO ANY PARTICULAR FONT, STYLE, SIZE, OR COLOR.

FOR VEHICLE RENTAL AND LEASING SERVICES, AND RESERVATION SERVICES FOR THE RENTAL AND LEASING OF VEHICLES (U.S. CLS. 100 AND 105).
ESTHER A. BORSUK, EXAMINING ATTORNEY

SN 85-496,613. SMITHSONIAN INSTITUTION, WASHINGTON, DC. FILED 12-15-2011.

EVOTOURISM

THE MARK CONSISTS OF STANDARD CHARACTERS WITHOUT CLAIM TO ANY PARTICULAR FONT, STYLE, SIZE, OR COLOR.

FOR PROVIDING TRAVEL INFORMATION SERVICES (U.S. CLS. 100 AND 105).

FIRST USE 12-19-2011; IN COMMERCE 12-19-2011.
WILLIAM ROSSMAN, EXAMINING ATTORNEY

CLASS 39—(Continued).

SN 85-515,293. JUNK DAWGS, INC., SPEEDWAY, IN. FILED 1-12-2012.



THE MARK CONSISTS OF TWO FORWARD-FACING DALMATIAN DOGS SITUATED BEHIND AN UPSIDE-DOWN FIREFIGHTER'S HELMET, WHICH BEARS THE WORDS "FIRE" AND "DEPT" AND THE NUMBER TWO.

FOR JUNK, TRASH AND DEBRIS REMOVAL (U.S. CLS. 100 AND 105).

FIRST USE 9-20-2011; IN COMMERCE 9-20-2011.
TAMARA FRAZIER, EXAMINING ATTORNEY

CLASS 40—MATERIAL TREATMENT

SN 85-034,170. WASTE-AWAY GROUP, LTD., ELKHART, IN. FILED 5-10-2010.

RECYCLING WORKS

THE MARK CONSISTS OF STANDARD CHARACTERS WITHOUT CLAIM TO ANY PARTICULAR FONT, STYLE, SIZE, OR COLOR.

NO CLAIM IS MADE TO THE EXCLUSIVE RIGHT TO USE "RECYCLING", APART FROM THE MARK AS SHOWN.

FOR RECYCLING SERVICES (U.S. CLS. 100, 103 AND 106).

FIRST USE 7-0-1989; IN COMMERCE 7-0-1989.
STEVEN R. FINE, EXAMINING ATTORNEY

CLASS 40—(Continued).

SN 85-271,557. BAYSHORE DENTAL STUDIO LLC, TAMPA, FL. FILED 3-19-2011.

BAYSHORE DENTAL STUDIO

THE MARK CONSISTS OF STANDARD CHARACTERS WITHOUT CLAIM TO ANY PARTICULAR FONT, STYLE, SIZE, OR COLOR.

NO CLAIM IS MADE TO THE EXCLUSIVE RIGHT TO USE "DENTAL STUDIO", APART FROM THE MARK AS SHOWN.

FOR DENTAL LABORATORIES (U.S. CLS. 100, 103 AND 106).

FIRST USE 0-0-2009; IN COMMERCE 0-0-2009.
JOHN KELLY, EXAMINING ATTORNEY

SN 85-297,440. TIOGA PIPE SUPPLY COMPANY, INC., PHILADELPHIA, PA. FILED 4-18-2011.

TIOGA PIPE

THE MARK CONSISTS OF STANDARD CHARACTERS WITHOUT CLAIM TO ANY PARTICULAR FONT, STYLE, SIZE, OR COLOR.

OWNER OF U.S. REG. NOS. 1,506,547 AND 1,506,548.

NO CLAIM IS MADE TO THE EXCLUSIVE RIGHT TO USE "PIPE", APART FROM THE MARK AS SHOWN.

SEC. 2(F).

FOR CUSTOM MANUFACTURING SERVICES IN THE FIELD OF PIPES, STEEL PLATES AND SHEETS, METAL FASTENERS, METAL RODS, METAL FORGINGS, CASTING ALLOYS, CARBON, STAINLESS AND CHROME ALLOY, SPECIALTY ALLOYS AND METALS, TUBULAR PRODUCTS, FITTINGS AND FLANGES AND RELATED PRODUCTS; METAL FABRICATION AND FINISHING SERVICES (U.S. CLS. 100, 103 AND 106).

FIRST USE 7-0-2010; IN COMMERCE 7-0-2010.
SUE LAWRENCE, EXAMINING ATTORNEY

SN 85-304,304. DUMAS HOLDINGS, LLC, MODESTO, CA. FILED 4-25-2011.

SIMPLY BRILLIANT PRESS

THE MARK CONSISTS OF STANDARD CHARACTERS WITHOUT CLAIM TO ANY PARTICULAR FONT, STYLE, SIZE, OR COLOR.

NO CLAIM IS MADE TO THE EXCLUSIVE RIGHT TO USE "PRESS", APART FROM THE MARK AS SHOWN.

FOR DESIGN PRINTING FOR OTHERS; DIGITAL ON-DEMAND PRINTING SERVICES OF BOOKS AND OTHER DOCUMENTS; LITHOGRAPHIC PRINTING; PHOTOGRAPHIC PRINTING; PRINTING; TYPESETTING (U.S. CLS. 100, 103 AND 106).

DOMINIC J. FERRAIUOLO, EXAMINING ATTORNEY

CLASS 40—(Continued).

SN 85-339,584. WHEELING AREA TRAINING CENTER FOR THE HANDICAPPED, INC., WHEELING, WV. FILED 6-7-2011.



THE MARK CONSISTS OF A GERMAN SHEPHERD DOG HOLDING A PARTIALLY SHREDDED PIECE OF PAPER CONTAINING THE WORDING "WATCHDOG", ALL ON A SHADED RECTANGLE BACKGROUND.

FOR DOCUMENT DESTRUCTION; DOCUMENT SHREDDING SERVICES (U.S. CLS. 100, 103 AND 106).

FIRST USE 11-18-2009; IN COMMERCE 11-18-2009.
ANNE FARRELL, EXAMINING ATTORNEY

SN 85-360,263. VISSER PRECISION CAST, LLC, DENVER, CO. FILED 6-30-2011.

VISSER PRECISION CAST

THE MARK CONSISTS OF STANDARD CHARACTERS WITHOUT CLAIM TO ANY PARTICULAR FONT, STYLE, SIZE, OR COLOR.

NO CLAIM IS MADE TO THE EXCLUSIVE RIGHT TO USE "PRECISION CAST", APART FROM THE MARK AS SHOWN.

FOR MANUFACTURING SERVICES, NAMELY, THE MANUFACTURE OF MOLDS FOR THE CASTING OF METAL ALLOY PARTS AND COMPONENTS TO ORDER AND/OR SPECIFICATION OF OTHERS; MANUFACTURING SERVICES, NAMELY, CUSTOM MANUFACTURE OF METAL ALLOY PARTS AND COMPONENTS TO ORDER AND/OR SPECIFICATION OF OTHERS (U.S. CLS. 100, 103 AND 106).

BRIAN NEVILLE, EXAMINING ATTORNEY

CLASS 40—(Continued).

SN 85-375,861. H 2 SONICS, LLC., GLASTONBURY, CT. FILED 7-20-2011.



THE MARK CONSISTS OF THE WORD "H2SONICS" WITH A CIRCULAR ATOM DESIGN POSITIONED ADJACENT THERETO.

FOR MANUFACTURING SERVICES FOR OTHERS IN THE FIELD OF HYDROGEN AND ALUMINA (U.S. CLS. 100, 103 AND 106).

FIRST USE 8-1-2009; IN COMMERCE 8-1-2009.
ALICE BENMAMAN, EXAMINING ATTORNEY

CLASS 40—(Continued).

SN 85-398,423. FINE DESIGNS, INC., TUKWILA, WA. FILED 8-15-2011.



NO CLAIM IS MADE TO THE EXCLUSIVE RIGHT TO USE "FINE DESIGNS IMPRINTED SPORTSWEAR", APART FROM THE MARK AS SHOWN.

THE MARK CONSISTS OF THE LETTERS "FD" IN STYLIZED FORMAT TO THE LEFT OF THE WORDS "FINE DESIGNS" OVER THE WORDING "IMPRINTED SPORTSWEAR," ALL IN A STYLIZED FONT.

FOR IMPRINTING MESSAGES ON SPORTSWEAR, NAMELY, ON-SITE IMPRINTING AT SPORTS EVENTS (U.S. CLS. 100, 103 AND 106).

FIRST USE 1-1-2003; IN COMMERCE 1-1-2003.
ALLISON SCHRODY, EXAMINING ATTORNEY

SN 85-380,165. RYAN BLOOM INC., SANTA ANA, CA. FILED 7-25-2011.



NO CLAIM IS MADE TO THE EXCLUSIVE RIGHT TO USE "OC RECYCLING.COM", APART FROM THE MARK AS SHOWN.

THE COLOR(S) ORANGE, GREEN, WHITE AND RED IS/ARE CLAIMED AS A FEATURE OF THE MARK.

THE MARK CONSISTS OF THE LITERAL ELEMENTS "OC RECYCLING.COM" WITH THE STYLIZED LETTERS "O" AND "C" APPEARING IN ORANGE AND RED AND THERE IS GREEN AND WHITE LEAF ABOVE THE LETTER "O". UNDERNEATH THE LETTERS "OC" THE WORD "RECYCLING.COM" IS WRITTEN IN GREEN COLOR AS SHOWN IN THE MARK.

FOR RECYCLING; RECYCLING OF WASTE; MATERIAL TREATMENT SERVICES IN CONNECTION WITH RECYCLING; RECYCLING OF ANY MATERIAL THAT CAN BE RECYCLED (U.S. CLS. 100, 103 AND 106).

FIRST USE 8-20-2010; IN COMMERCE 8-20-2010.
CHARLES L. JENKINS, EXAMINING ATTORNEY

SN 85-400,571. HOROWITZ, DAVID, ST. PETERSBURG, FL. AND HOROWITZ, PATRICIA, ST. PETERSBURG, FL. FILED 8-17-2011.

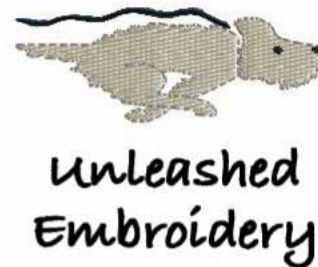

NO CLAIM IS MADE TO THE EXCLUSIVE RIGHT TO USE "EMBROIDERY", APART FROM THE MARK AS SHOWN.

THE STIPPLING IS FOR SHADING PURPOSES ONLY.

THE MARK CONSISTS OF A RUNNING DOG WITH LEASH AND THE TEXT "UNLEASHED EMBROIDERY" BELOW IT.

FOR EMBROIDERY SERVICES (U.S. CLS. 100, 103 AND 106).

FIRST USE 8-1-2011; IN COMMERCE 8-1-2011.
HANNO RITTNER, EXAMINING ATTORNEY

CLASS 40—(Continued).

SN 85-415,593. VITA-HERB NUTRICEUTICALS, INC., PLACENTIA, CA. FILED 9-6-2011.

NPIB

THE MARK CONSISTS OF STANDARD CHARACTERS WITHOUT CLAIM TO ANY PARTICULAR FONT, STYLE, SIZE, OR COLOR.

OWNER OF U.S. REG. NO. 3,780,664.
FOR ENCAPSULATING SERVICES, NAMELY, MANUFACTURING CAPSULES FOR HUMAN CONSUMPTION IN THE PHARMACEUTICAL AND NUTRACEUTICAL INDUSTRIES (U.S. CLS. 100, 103 AND 106).

FIRST USE 0-0-2001; IN COMMERCE 0-0-2002.
ALICE BENMAMAN, EXAMINING ATTORNEY

SN 85-427,136. ACTION METALS, INC., DALLAS, TX. FILED 9-20-2011.

ACTION METALS RECYCLERS

THE MARK CONSISTS OF STANDARD CHARACTERS WITHOUT CLAIM TO ANY PARTICULAR FONT, STYLE, SIZE, OR COLOR.

NO CLAIM IS MADE TO THE EXCLUSIVE RIGHT TO USE "METALS RECYCLERS", APART FROM THE MARK AS SHOWN.

FOR RECYCLING (U.S. CLS. 100, 103 AND 106).
NAKIA HENRY, EXAMINING ATTORNEY

SN 85-432,072. GREEN SIGN COMPANY, INC., GREENSBURG, IN. FILED 9-26-2011.

GREEN SIGN

THE MARK CONSISTS OF STANDARD CHARACTERS WITHOUT CLAIM TO ANY PARTICULAR FONT, STYLE, SIZE, OR COLOR.

OWNER OF U.S. REG. NO. 3,014,645.
NO CLAIM IS MADE TO THE EXCLUSIVE RIGHT TO USE "SIGN", APART FROM THE MARK AS SHOWN.

FOR CUSTOM SIGNAGE CONSTRUCTION FOR OTHERS (U.S. CLS. 100, 103 AND 106).
FIRST USE 5-12-2006; IN COMMERCE 7-1-2006.
ANDREW RHIM, EXAMINING ATTORNEY

CLASS 40—(Continued).

SN 85-445,452. SHOREWOOD PACKAGING CORPORATION, STAMFORD, CT. FILED 10-12-2011.

REFLEXIONS

THE MARK CONSISTS OF STANDARD CHARACTERS WITHOUT CLAIM TO ANY PARTICULAR FONT, STYLE, SIZE, OR COLOR.

FOR COATING AND PRINTING ON PAPER AND PAPERBOARD, AND CONVERTING OF PAPER AND PAPERBOARD INTO CONSUMER PRODUCT PACKAGING (U.S. CLS. 100, 103 AND 106).

CIMMERIAN COLEMAN, EXAMINING ATTORNEY

SN 85-445,494. PLCIP, L.L.C., SALISBURY, MD. FILED 10-12-2011.

**DYLAN ENERGY,
This is it.**

THE MARK CONSISTS OF STANDARD CHARACTERS WITHOUT CLAIM TO ANY PARTICULAR FONT, STYLE, SIZE, OR COLOR.

NO CLAIM IS MADE TO THE EXCLUSIVE RIGHT TO USE "ENERGY", APART FROM THE MARK AS SHOWN.

FOR GENERATION OF ENERGY (U.S. CLS. 100, 103 AND 106).

LINDA M. KING, EXAMINING ATTORNEY

SN 85-445,807. TRS GROUP, INC., LONGVIEW, WA. FILED 10-12-2011.



OWNER OF U.S. REG. NO. 4,060,203.

THE COLOR(S) RED, ORANGE AND WHITE IS/ARE CLAIMED AS A FEATURE OF THE MARK.

THE MARK CONSISTS OF A CIRCLE GRADING FROM RED COLOR AT TOP TO ORANGE COLOR AT BOTTOM WITH THREE SMALLER CIRCLES IN WHITE ASSEMBLED WITHIN IN A TRIANGULAR PATTERN AND WITH WHITE LINES PASSING THROUGH THE LOCATIONS THAT INTERSECT TWO OF THE SMALLER CIRCLES AND THE LETTERS "TRS" IN ORANGE.

FOR ENVIRONMENTAL REMEDIATION SERVICES, NAMELY, TREATMENT OF SOIL AND GROUND-WATER (U.S. CLS. 100, 103 AND 106).

FIRST USE 4-21-2009; IN COMMERCE 4-21-2009.
DOUGLAS LEE, EXAMINING ATTORNEY

CLASS 40—(Continued).

SN 85-446,891. R.H. ROSENFELD CO., SANFORD, ME.
FILED 10-13-2011.

PRINTEMS.COM

THE MARK CONSISTS OF STANDARD CHARACTERS WITHOUT CLAIM TO ANY PARTICULAR FONT, STYLE, SIZE, OR COLOR.

FOR CUSTOM IMPRINTING OF PAPER OR MERCHANDISE; DESIGN PRINTING FOR OTHERS; DIGITAL ON-DEMAND PRINTING SERVICES OF BOOKS AND OTHER DOCUMENTS; DIGITAL PRINTING; PRINTING SERVICES (U.S. CLS. 100, 103 AND 106).
YAT SYE, LEE, EXAMINING ATTORNEY

SN 85-447,111. ACCELERGY CORPORATION, HOUSTON, TX. FILED 10-13-2011.

TERRASYNC

THE MARK CONSISTS OF STANDARD CHARACTERS WITHOUT CLAIM TO ANY PARTICULAR FONT, STYLE, SIZE, OR COLOR.

FOR CONSULTATION IN THE FIELD OF PRODUCING, TREATING AND REFINING FUELS; PRODUCTION, TREATMENT AND REFINEMENT OF FUEL FOR OTHERS (U.S. CLS. 100, 103 AND 106).

RON FAIRBANKS, EXAMINING ATTORNEY

SN 85-447,874. APPLIED TEXTILES, INC., BYRON CENTER, MI. FILED 10-14-2011.

STILETTO

THE MARK CONSISTS OF STANDARD CHARACTERS WITHOUT CLAIM TO ANY PARTICULAR FONT, STYLE, SIZE, OR COLOR.

FOR TREATMENT OF TEXTILES AND FABRICS WITH PROTECTANTS AND PUNCTURE RESISTANT BACKINGS (U.S. CLS. 100, 103 AND 106).

EMILY CARLSEN, EXAMINING ATTORNEY

CLASS 40—(Continued).

SN 85-447,974. ELECTRONIC IMAGING SERVICES, INC., DBA VESTCOM RETAIL SOLUTIONS, LITTLE ROCK, AR. FILED 10-14-2011.

AisleWise

THE MARK CONSISTS OF STANDARD CHARACTERS WITHOUT CLAIM TO ANY PARTICULAR FONT, STYLE, SIZE, OR COLOR.

FOR CUSTOMIZED DIGITAL PRINTING OF MARKETING TOOLS FOR RETAILERS; PRINTING OF PLANOGRAMS FOR RETAILERS; PRINTING OF PRICING LABELS FOR RETAILERS THAT ARE PRINTED AT PRESET INTERVALS TO COMPLY WITH PRODUCT PLACEMENT GUIDELINES (U.S. CLS. 100, 103 AND 106).

RONALD MCMORROW, EXAMINING ATTORNEY

SN 85-460,939. DOWNEY RIDGE ENVIRONMENTAL COMPANY, ANSTED, WV. FILED 10-31-2011.



THE COLOR(S) GREEN, RED, ORANGE, YELLOW, BLACK AND WHITE IS/ARE CLAIMED AS A FEATURE OF THE MARK.

THE MARK CONSISTS OF A SIDE PROFILE VIEW OF A DRAGON TYPE HEAD FACING TO THE RIGHT. THE DRAGON IS BEARING ITS TEETH. AT THE BACK OF THE DRAGON'S HEAD IS A BURST OF FLAME EXITING TO THE LEFT. THE DRAGON'S HEAD IS SUBSTANTIALLY IN THE COLOR GREEN WITH BLACK PIPING. THE DRAGON'S TEETH ARE WHITE. THE DRAGON'S EYES ARE RED, BLACK AND WHITE. THE FLAME EXITS THE DRAGON'S HEAD IN THE COLOR RED AND THEN TRANSITIONS INTO THE COLORS ORANGE AND YELLOW. THE FIRE IS ALSO OUTLINED IN BLACK PIPING. THE WORD "GREASEZILLA" IS LOCATED UNDERNEATH THE DRAGON'S HEAD AND IS ORANGE IN COLOR WITH BLACK PIPING.

FOR FAT, OIL, AND GREASE (FOG) MANAGEMENT SERVICES, NAMELY, CONVERTING COLLECTED BROWN SEWER GREASE AND FOG TO BIOFUELS (U.S. CLS. 100, 103 AND 106).

FIRST USE 2-25-2011; IN COMMERCE 2-25-2011.

DAVID MURRAY, EXAMINING ATTORNEY

CLASS 41—EDUCATION AND ENTERTAINMENT

SN 76-706,898. TRI-STATE LOTTO COMMISSION, BARRE, VT. FILED 3-21-2011.



OWNER OF U.S. REG. NOS. 2,783,685 AND 3,558,027.
NO CLAIM IS MADE TO THE EXCLUSIVE RIGHT TO USE "TRI-STATE", "WEEKLY GRAND", "VERMONT" AND THE \$ SIGN, APART FROM THE MARK AS SHOWN.

THE MARK CONSISTS OF "TRI-STATE" ON THE TOP LEFT SIDE OF THE MARK ABOVE A \$ SIGN WHICH IS TO THE LEFT OF "EXTRA", WITH ALL THREE BEING ABOVE "WEEKLY GRAND" AND THEN "VERMONT". ALL OF THE WORDING IS CONTAINED WITHIN A STYLIZED DESIGN OUTLINING SUCH WORDING AND \$ SIGN.

FOR LOTTERY GAME SERVICES (U.S. CLS. 100, 101 AND 107).

FIRST USE 5-30-2011; IN COMMERCE 5-30-2011.
KARANENDRA S. CHHINA, EXAMINING ATTORNEY

SN 76-709,437. PARKER, ROBERT L., PITTSBURGH, PA. FILED 10-18-2011.

FINANCIAL SURCURITY!

THE MARK CONSISTS OF STANDARD CHARACTERS WITHOUT CLAIM TO ANY PARTICULAR FONT, STYLE, SIZE, OR COLOR.

FOR PRODUCTION OF MOVIES (U.S. CLS. 100, 101 AND 107).

AISHA CLARKE, EXAMINING ATTORNEY

SN 76-709,908. PARKER, ROBERT L., PITTSBURGH, PA. FILED 12-6-2011.

MILLIONAIRE NOW!

THE MARK CONSISTS OF STANDARD CHARACTERS WITHOUT CLAIM TO ANY PARTICULAR FONT, STYLE, SIZE, OR COLOR.

FOR PRODUCTION OF MOVIES (U.S. CLS. 100, 101 AND 107).

AISHA CLARKE, EXAMINING ATTORNEY

CLASS 41—(Continued).

SN 77-033,302. TRACEY L. CROISIER, BELLEVUE, WA. FILED 10-31-2006.

MISS PINK

THE MARK CONSISTS OF STANDARD CHARACTERS WITHOUT CLAIM TO ANY PARTICULAR FONT, STYLE, SIZE, OR COLOR.

FOR ENTERTAINMENT SERVICES, NAMELY, PROVIDING ON-LINE STORIES IN THE FIELD OF MEMOIRS (U.S. CLS. 100, 101 AND 107).

FIRST USE 9-1-2005; IN COMMERCE 9-1-2005.
DOMINICK J. SALEMI, EXAMINING ATTORNEY

SN 77-287,925. THE GENERAL COUNCIL OF THE ASSEMBLIES OF GOD, DBA GOSPEL PUBLISHING HOUSE, SPRINGFIELD, MO. FILED 9-25-2007.

GOSPEL PUBLISHING HOUSE

THE MARK CONSISTS OF STANDARD CHARACTERS WITHOUT CLAIM TO ANY PARTICULAR FONT, STYLE, SIZE, OR COLOR.

NO CLAIM IS MADE TO THE EXCLUSIVE RIGHT TO USE "PUBLISHING HOUSE", APART FROM THE MARK AS SHOWN.

SEC. 2(F).

FOR EDUCATION INFORMATION; ENTERTAINMENT INFORMATION IN THE FIELD OF RELIGIOUS MUSIC AND RELIGIOUS ENTERTAINMENT; ENTERTAINMENT SERVICES, NAMELY, PROVIDING WEB SITES FEATURING PHOTOGRAPHIC, AUDIO, VIDEO AND PROSE PRESENTATIONS FEATURING RELIGION; ENTERTAINMENT SERVICES, NAMELY, PROVIDING PODCASTS IN THE FIELD OF RELIGION; PROVIDING NEWSLETTERS IN THE FIELD OF RELIGION VIA E-MAIL; PUBLISHING OF BOOKS, MAGAZINES AND PERIODICALS; RELIGIOUS INSTRUCTION SERVICES (U.S. CLS. 100, 101 AND 107).

FIRST USE 0-0-1914; IN COMMERCE 0-0-1914.
TRICIA SONNEBORN, EXAMINING ATTORNEY

SN 77-295,145. GOSNELL, EVAN, ROCKVILLE, MD. FILED 10-3-2007.

EGOZ.entertainment.

THE MARK CONSISTS OF STANDARD CHARACTERS WITHOUT CLAIM TO ANY PARTICULAR FONT, STYLE, SIZE, OR COLOR.

FOR ENTERTAINMENT SERVICES, NAMELY, PROVIDING A WEB SITE FEATURING PORNOGRAPHIC VIDEOS, RELATED FILM CLIPS, PHOTOGRAPHS, AND OTHER MULTIMEDIA MATERIALS (U.S. CLS. 100, 101 AND 107).

ELISSA GARBER KON, EXAMINING ATTORNEY

CLASS 41—(Continued).

SN 77-309,044. CHILDREN'S AID SOCIETY OF PENNSYLVANIA, PHILADELPHIA, PA. FILED 10-19-2007.

TIME OUT FOR TEENS AND TOTS

THE MARK CONSISTS OF STANDARD CHARACTERS WITHOUT CLAIM TO ANY PARTICULAR FONT, STYLE, SIZE, OR COLOR.

FOR SOCIAL SERVICES PROGRAM, NAMELY, PROVIDING EDUCATIONAL CLASSES AND SEMINARS TO TEEN PARENTS AND THEIR CHILDREN IN THE AREA OF PARENTING SKILLS AND PERSONAL DEVELOPMENT AND PROVIDING EDUCATION AND PLAY CLASSES FOCUSING ON PHYSICAL AND MENTAL DEVELOPMENT ACTIVITIES FOR CHILDREN AND THEIR TEEN PARENTS (U.S. CLS. 100, 101 AND 107).

FIRST USE 10-16-1988; IN COMMERCE 10-16-1988.
REBECCA GILBERT, EXAMINING ATTORNEY

CLASS 41—(Continued).

SN 79-100,006. PICTURE CONTACT BV, NETHERLANDS, FILED 3-21-2011.

TRVL

THE MARK CONSISTS OF STANDARD CHARACTERS WITHOUT CLAIM TO ANY PARTICULAR FONT, STYLE, SIZE, OR COLOR.

PRIORITY DATE OF 3-3-2011 IS CLAIMED.
OWNER OF INTERNATIONAL REGISTRATION 1084167 DATED 3-21-2011, EXPIRES 3-21-2021.

FOR PUBLICATIONS OF TEXTS AND IMAGERY IN THE FORM OF ELECTRONIC MEDIA, NAMELY, PUBLICATION OF MAGAZINES AND E-ZINES; PUBLICATIONS OF PRINTED MATTER; PRODUCTION OF TEXTS AND IMAGERY IN THE FORM OF ELECTRONIC MEDIA, EXCEPT FOR ADVERTISING PURPOSES, NAMELY, PUBLICATION OF E-ZINES, PROVIDING IMAGES AND TEXT FEATURING TRAVEL STORIES AND ARTICLES AND PICTURES ON-LINE (U.S. CLS. 100, 101 AND 107).

CARYN GLASSER, EXAMINING ATTORNEY

SN 85-014,554. INTERNATIONAL BIOCENTRIC FOUNDATION LTD, DUBLIN, IRELAND, FILED 4-15-2010.



OWNER OF ERPN CMNTY TM OFC REG. NO. 008396541, DATED 1-12-2010, EXPIRES 6-30-2019.

NO CLAIM IS MADE TO THE EXCLUSIVE RIGHT TO USE "DANCE" AND "SYSTEM", APART FROM THE MARK AS SHOWN.

THE NAME "ROLANDO TORO" DOES NOT IDENTIFY A LIVING INDIVIDUAL.

THE MARK CONSISTS OF THE WORDING "BIOCENTRIC DANCE ROLANDO TORO SYSTEM" AND A REPRESENTATION OF A CRANE. A CIRCLE WITH BROKEN LINES SERVES AS A BORDER.

FOR EDUCATIONAL SERVICES, NAMELY, CONDUCTING WORKSHOPS, SEMINARS, ADVANCED EDUCATION AND ADVANCED TRAINING FOR PROFESSIONALS RELATING TO THERAPEUTIC APPLICATION OF DANCE, MOTION, MUSIC AND SINGING IN THE FIELD OF PSYCHOTHERAPY AND DISTRIBUTION OF PRINTED MATERIALS IN CONNECTION THEREWITH IN HARD COPY OR ELECTRONIC FORMAT ON THE SAME TOPICS; ENTERTAINMENT, NAMELY, PRODUCTION OF DANCE, MOTION AND MUSIC SHOWS; PUBLICATION OF BOOKS, MAGAZINES, JOURNALS, PERIODICALS, AND BROCHURES (U.S. CLS. 100, 101 AND 107).

PRISCILLA MILTON, EXAMINING ATTORNEY

SN 77-944,006. PARMACOTTO, S.P.A., PARMA, ITALY, FILED 2-24-2010.



OWNER OF ERPN CMNTY TM OFC REG. NO. 007240856, DATED 5-11-2009, EXPIRES 9-18-2018.

NO CLAIM IS MADE TO THE EXCLUSIVE RIGHT TO USE "SALUMERIA", APART FROM THE MARK AS SHOWN.

THE COLOR(S) BORDEAUX RED AND WHITE IS/ARE CLAIMED AS A FEATURE OF THE MARK.

THE MARK CONSISTS OF A RECTANGULAR BOX IN BORDEAUX RED WITH THE STYLIZED WORDING "SALUMERIA ROSI PARMACOTTO" IN WHITE INSIDE OF THE BOX.

THE ENGLISH TRANSLATION OF "SALUMERIA" IN THE MARK IS "DELICATESSEN". THE WORDING "ROSI PARMACOTTO" HAS NO MEANING IN A FOREIGN LANGUAGE.

FOR ENTERTAINMENT SERVICES, NAMELY, PROVIDING TRAINING COURSES IN THE FIELD OF WINE AND GASTRONOMY (U.S. CLS. 100, 101 AND 107).

ANNE MADDEN, EXAMINING ATTORNEY

CLASS 41—(Continued).

SN 85-104,042. TELEVISION FOOD NETWORK, G.P., NEW YORK, NY. FILED 8-10-2010.

SPICE & EASY

THE MARK CONSISTS OF STANDARD CHARACTERS WITHOUT CLAIM TO ANY PARTICULAR FONT, STYLE, SIZE, OR COLOR.

NO CLAIM IS MADE TO THE EXCLUSIVE RIGHT TO USE "SPICE", APART FROM THE MARK AS SHOWN.

FOR EDUCATIONAL AND ENTERTAINMENT SERVICES, NAMELY, A CONTINUING PROGRAM ABOUT FOOD AND COOKING, ACCESSIBLE BY RADIO, TELEVISION, CABLE, FIBER OPTIC NETWORKS, WIRELESS NETWORKS, SATELLITE, AUDIO VIDEO, AND COMPUTER NETWORKS (U.S. CLS. 100, 101 AND 107).

FIRST USE 4-24-2010; IN COMMERCE 4-24-2010.

ALLISON HOLTZ, EXAMINING ATTORNEY

SN 85-130,022. CJ 4DPLEX CO., LTD., SEOUL, REPUBLIC OF KOREA, FILED 9-15-2010.

4DPLEX

THE MARK CONSISTS OF STANDARD CHARACTERS WITHOUT CLAIM TO ANY PARTICULAR FONT, STYLE, SIZE, OR COLOR.

PRIORITY CLAIMED UNDER SEC. 44(D) ON REPUBLIC OF KOREA APPLICATION NO. 2010-0023476, FILED 9-10-2010, REG. NO. 0223564, DATED 12-23-2011, EXPIRES 12-23-2021.

FOR CINEMA THEATERS; CINEMA THEATERS PROVIDING MOVIE AUDIENCE EFFECTS SUCH AS WIND, SCENT, WATER SPRAY, MOTION, VIBRATION, SMOKE, BUBBLE, LASER OR FLASH; PRODUCTION OF RADIO AND TELEVISION PROGRAMS; PRESENTATION OF LIVE SHOW PERFORMANCES; PRESENTATION OF MUSICAL PERFORMANCE; IMPRESARIO SERVICES, NAMELY, ORGANIZATION OF LIVE SHOW PERFORMANCES IN THE FIELD OF MOVIES; ANIMATION PRODUCTION SERVICES; ENTERTAINMENT IN THE NATURE OF LIVE STAGE PERFORMANCES IN THE NATURE OF PLAYS AND CONCERTS; DISTRIBUTION OF MOTION PICTURE FILMS; ENTERTAINMENT SERVICES, NAMELY, PLANNING AND CONDUCTING A SERIES OF FILM FESTIVALS; FILM PRODUCTION; MOVIE STUDIOS; RENTAL OF CINE-FILMS; PUBLICATION OF PERIODICALS; NIGHT CLUBS; VIDEOTAPING; NEWS REPORTERS SERVICES; PROVIDING AMUSEMENT FACILITIES; ARRANGING FOR TICKET RESERVATIONS FOR MOVIES; ARRANGING FOR TICKET RESERVATIONS FOR SHOWS AND OTHER ENTERTAINMENT EVENTS; PROVISION OF ENTERTAINMENT INFORMATION AND DATA CONCERNING MOVIES (U.S. CLS. 100, 101 AND 107).

RON FAIRBANKS, EXAMINING ATTORNEY

CLASS 41—(Continued).

SN 85-131,482. WHOLESOME HOME, LLC, DBA THE HEALTHY HOME SHOW, OMAHA, NE. FILED 9-16-2010.



OWNER OF U.S. REG. NO. 3,873,621.

NO CLAIM IS MADE TO THE EXCLUSIVE RIGHT TO USE "HEALTHY HOME SHOW", APART FROM THE MARK AS SHOWN.

THE COLOR(S) BLACK, GREEN, BLUE, GOLD, AND GRAY IS/ARE CLAIMED AS A FEATURE OF THE MARK.

THE MARK CONSISTS OF THE WORDING "THE HEALTHY HOME SHOW, WITH THE WORDING "THE" IN THE COLOR BLACK, "HEALTHY" IN THE COLOR GREEN, AND "HOME SHOW" IN THE COLOR BLUE; A TRANSMITTING TOWER IN THE COLORS GRAY AND BLACK STANDS IN THE PLACE OF THE LETTER 'A' IN THE WORDING "HEALTHY" AND A SPHERE WITH CONCENTRIC SOUND WAVES, ALL IN THE COLOR GOLD, APPEAR TO EMANATE FROM THE TRANSMISSION TOWER.

FOR EDUCATIONAL AND ENTERTAINMENT SERVICES, NAMELY, A CONTINUING PROGRAM ABOUT HOME IMPROVEMENT ACCESSIBLE BY RADIO, TELEVISION, SATELLITE, AUDIO, VIDEO AND COMPUTER NETWORKS (U.S. CLS. 100, 101 AND 107).

FIRST USE 10-0-1996; IN COMMERCE 10-0-1996.

SUZANNE BLANE, EXAMINING ATTORNEY

SN 85-141,998. THE RITZ-CARLTON HOTEL COMPANY, L.L.C., BETHESDA, MD. FILED 9-30-2010.

RITZ

THE MARK CONSISTS OF STANDARD CHARACTERS WITHOUT CLAIM TO ANY PARTICULAR FONT, STYLE, SIZE, OR COLOR.

OWNER OF U.S. REG. NOS. 1,535,834, 2,869,095 AND 2,934,838.

FOR EDUCATIONAL AND ENTERTAINMENT SERVICES, NAMELY, ARRANGING AND CONDUCTING SEMINARS, WORKSHOPS, CLASSES, CONFERENCES, AND SYMPOSIUMS IN THE FIELD OF LEADERSHIP DEVELOPMENT, HUMAN RESOURCES, CUSTOMER SERVICE, CUSTOMER AND EMPLOYEE SATISFACTION AND LOYALTY, EMPLOYEE RECRUITMENT, AND EMPLOYEE ORIENTATION, TRAINING, AND DEVELOPMENT, AND DISTRIBUTION OF MATERIALS IN CONNECTION THEREWITH; CASINO SERVICES; CABARET SERVICES; NIGHTCLUB SERVICES; ARRANGING FOR TICKET RESERVATIONS FOR SHOWS AND OTHER ENTERTAINMENT EVENTS; HEALTH AND FITNESS CLUB SERVICES, NAMELY, PROVIDING INSTRUCTION AND EQUIPMENT IN THE FIELD OF PHYSICAL EXERCISE; PROVIDING FACILITIES AND EQUIPMENT FOR FITNESS, EXERCISE, TENNIS, SWIMMING, RECREATIONAL ACTIVITIES, BICY-

CLASS 41—(Continued).

CLING, GOLF, WATER SPORTS, HORSEBACK RIDING AND SKIING; GOLF CLUB, GOLF COURSE AND GOLF INSTRUCTION SERVICES; CONSULTATION AND COORDINATION OF SPECIAL EVENTS FOR SOCIAL ENTERTAINMENT PURPOSES, WEDDING PLANNING CONSULTATION AND COORDINATION SERVICES; EVENT PLANNING AND MANAGEMENT SERVICES, NAMELY, ARRANGING, ORGANIZING, SCHEDULING AND DESIGNING SPECIAL EVENTS FOR SOCIAL ENTERTAINMENT PURPOSES; WEDDING PARTY PLANNING SERVICES; CONDUCTING EDUCATIONAL CLASSES, PROGRAMS, AND WORKSHOPS IN THE FIELD OF ART, FOREIGN LANGUAGES, ETIQUETTE, ARTS AND CRAFTS, NATURE, AND CONSERVATION; PROVIDING HOTEL GUESTS WITH EDUCATIONAL AND ENTERTAINMENT INFORMATION ABOUT LOCAL ATTRACTIONS AND POINTS OF INTEREST; ART EXHIBITIONS; PROVIDING BEACH FACILITIES FOR SWIMMING AND BATHING; COUNTRY CLUBS; RENTAL OF SKIN DIVING AND SCUBA DIVING EQUIPMENT (U.S. CLS. 100, 101 AND 107).

GENE MACIOL, EXAMINING ATTORNEY

SN 85-148,410. PENNSYLVANIA FRIENDS OF AGRICULTURE FOUNDATION, CAMP HILL, PA. FILED 10-8-2010.



THE COLOR(S) WHITE, BLACK, BLUE, GREEN AND RED IS/ARE CLAIMED AS A FEATURE OF THE MARK.

THE MARK CONSISTS OF A WHITE AND BLACK BARN DESIGN AND BLUE, GREEN AND RED SCIENTIFIC TEST TUBES OUTLINED IN BLACK NEXT TO THE BARN.

FOR EDUCATIONAL SERVICES, NAMELY, COURSES, CLASSES AND SEMINARS IN THE FIELD OF SCIENCE BY MEANS OF A MOBILE SCIENCE LABORATORY CONTAINED IN A TRAILER (U.S. CLS. 100, 101 AND 107).

REGINA DRUMMOND, EXAMINING ATTORNEY

CLASS 41—(Continued).

SN 85-149,874. GLABBER, INC., NEWARK, DE. FILED 10-11-2010.

GLABBER

THE MARK CONSISTS OF STANDARD CHARACTERS WITHOUT CLAIM TO ANY PARTICULAR FONT, STYLE, SIZE, OR COLOR.

FOR PROVIDING AN ONLINE SEARCHABLE COMPUTER DATABASE FEATURING ENTERTAINMENT INFORMATION, SPORTS TRAINING INFORMATION, INFORMATION RELATING TO SPORTS AND SPORTING EVENTS AND INFORMATION RELATING TO ORGANIZING COMMUNITY SPORTING AND CULTURAL ACTIVITIES, CONTESTS AND GAMES; PROVIDING RATING SYSTEM SERVICES, NAMELY, PROVIDING A WEB SITE WHERE USERS CAN POST RATINGS, REVIEWS AND RECOMMENDATIONS ON EVENTS AND ACTIVITIES IN THE FIELD OF ENTERTAINMENT AND EDUCATION; PROVIDING A WEBSITE FEATURING NON-DOWNLOADABLE VIDEOS IN THE FIELD OF MUSIC, MOVIES AND SPORTS (U.S. CLS. 100, 101 AND 107).

JAMES LOVELACE, EXAMINING ATTORNEY

SN 85-156,569. BABY NETWORK LIMITED, LONDON, UNITED KINGDOM, FILED 10-19-2010.



THE MARK CONSISTS OF THE STYLIZED WORD "PICARO" ON WHICH THE LETTER "P" APPEARS WITH A BACKGROUND OF WOOD GRAIN AND AN IMAGE OF A PONYTAIL APPEARING FROM THE TOP LEFT; THE LETTER "I" APPEARS WITH A BACKGROUND OF WOOD

CLASS 41—(Continued).

GRAIN AND AN IMAGE OF AN IMAGINARY CHARACTER'S FACE WITH FIVE PONYTAILS ON HIS HEAD; THE LETTER "C" APPEARS WITH A BACKGROUND OF WOOD GRAIN AND AN IMAGE OF A SCREW APPEARING INSIDE THE LETTER "C"; THE LETTER "A" APPEARS WITH BUMPS RISING FROM THE TOP; THE LETTER "R" APPEARS WITH A BACKGROUND OF WOOD GRAIN; AND THE LETTER "O" IS THE IMAGE OF A FROG WITH AN IMAGE OF A SCREW APPEARING INSIDE THE LETTER "O".

FOR PROVIDING ON-LINE INFORMATION IN THE FIELD OF LANGUAGE INSTRUCTION AND CHILDREN'S ENTERTAINMENT VIA THE INTERNET; ENTERTAINMENT SERVICES IN THE NATURE OF NON-DOWNLOADABLE INSTRUCTIONAL VIDEOS AND IMAGES FEATURING LANGUAGE INSTRUCTION, SPEECH DEVELOPMENT AND CHILDREN'S ENTERTAINMENT TRANSMITTED VIA THE INTERNET AND WIRELESS COMMUNICATION NETWORKS; PRODUCTION AND DISTRIBUTION OF NON-DOWNLOADABLE VIDEOS AND IMAGES IN THE FIELD OF LANGUAGE INSTRUCTION, SPEECH DEVELOPMENT AND CHILDREN'S ENTERTAINMENT TRANSMITTED VIA THE INTERNET AND WIRELESS COMMUNICATION NETWORKS; PROVIDING ON-LINE COMPUTER GAMES; ON-LINE ELECTRONIC NEWSLETTERS DELIVERED BY E-MAIL IN THE FIELD OF LANGUAGE, SPEECH DEVELOPMENT AND CHILDREN'S ENTERTAINMENT; ON-LINE JOURNALS, NAMELY, BLOGS FEATURING PERSONAL OPINIONS IN THE FIELD OF GENERAL INTEREST, LANGUAGE, SPEECH DEVELOPMENT AND CHILDREN'S ENTERTAINMENT (U.S. CLS. 100, 101 AND 107).

STEVEN JACKSON, EXAMINING ATTORNEY

SN 85-187,814. ZYNGA INC., SAN FRANCISCO, CA. FILED 11-30-2010.



The logo for "Treasure Isle" features the words "Treasure Isle" in a stylized, bubbly font. The letter "I" in "Isle" is replaced by a shovel standing upright on a small patch of dirt, with several coins scattered to its left.

THE MARK CONSISTS OF THE WORDS "TREASURE ISLE" WITH THE IMAGE OF A SHOVEL AS THE LETTER "I" STANDING UPRIGHT ON DIRT WITH COINS TO THE LEFT OF THE SHOVEL UNDER THE WORDS.

FOR PROVIDING ONLINE COMPUTER GAMES; PROVIDING ONLINE VIDEO GAMES (U.S. CLS. 100, 101 AND 107).

FIRST USE 4-1-2010; IN COMMERCE 4-1-2010.
KATHERINE CHANG, EXAMINING ATTORNEY

SN 85-188,628. REFERRAL INSTITUTE, LLC, ROHNERT PARK, CA. FILED 12-1-2010.



The logo for "VCP" consists of the letters "VCP" in a bold, serif font. The letter "V" is significantly larger than the "C" and "P", and the "C" and "P" are positioned to the right of the "V".

THE MARK CONSISTS OF STANDARD CHARACTERS WITHOUT CLAIM TO ANY PARTICULAR FONT, STYLE, SIZE, OR COLOR.

OWNER OF U.S. REG. NO. 3,752,602.
FOR EDUCATION SERVICES, NAMELY, PROVIDING CLASSES AND SEMINARS IN THE FIELD OF REFERRAL MARKETING AND NETWORKING EDUCATION (U.S. CLS. 100, 101 AND 107).

FIRST USE 9-1-1999; IN COMMERCE 9-1-1999.
MICHAEL GAAFAR, EXAMINING ATTORNEY

CLASS 41—(Continued).

SN 85-201,871. GAUTHIER, BRYAN J., DBA SOMETHING BETTER COMPANY, LLC, PHOENIX, AZ. FILED 12-20-2010.

Improvement Heroes

THE MARK CONSISTS OF STANDARD CHARACTERS WITHOUT CLAIM TO ANY PARTICULAR FONT, STYLE, SIZE, OR COLOR.

NO CLAIM IS MADE TO THE EXCLUSIVE RIGHT TO USE "IMPROVEMENT", APART FROM THE MARK AS SHOWN.

FOR CONTINUING EDUCATION SERVICES, NAMELY, PROVIDING LIVE AND ON-LINE CONTINUING PROFESSIONAL EDUCATION SEMINARS IN THE FIELD OF DECORATIVE CONCRETE, HOME IMPROVEMENT, ART, CONTRACTING, PERSONAL IMPROVEMENT, HEALTH AND FITNESS, GENERAL TRADES, PRODUCTION TRADES, BUSINESS AND DIY HOME IMPROVEMENT AND DISTRIBUTING OF TRAINING MATERIALS SUCH AS DVDS, TECH MANUALS AND BOOKS; EDUCATION AND ENTERTAINMENT SERVICES, NAMELY, ONGOING TELEVISION PUBLIC SERVICE ANNOUNCEMENTS AND ONGOING TELEVISION PROGRAMS IN THE FIELD OF DECORATIVE CONCRETE, HOME IMPROVEMENT, ART, CONTRACTING, PERSONAL IMPROVEMENT, HEALTH AND FITNESS, GENERAL TRADES, PRODUCTION TRADES, BUSINESS AND DIY HOME IMPROVEMENT AND DISTRIBUTING OF TRAINING MATERIALS SUCH AS DVDS, TECH MANUALS AND BOOKS; EDUCATION IN THE FIELDS OF DECORATIVE CONCRETE, HOME IMPROVEMENT, ART, CONTRACTING, PERSONAL IMPROVEMENT, HEALTH AND FITNESS, GENERAL TRADES, PRODUCTION TRADES, BUSINESS AND DIY HOME IMPROVEMENT AND DISTRIBUTING OF TRAINING MATERIALS SUCH AS DVDS, TECH MANUALS AND BOOKS; EDUCATION SERVICES, NAMELY, ONE-ON-ONE MENTORING IN THE FIELDS OF DECORATIVE CONCRETE, HOME IMPROVEMENT, ART, CONTRACTING, PERSONAL IMPROVEMENT, HEALTH AND FITNESS, GENERAL TRADES, PRODUCTION TRADES, BUSINESS AND DIY HOME IMPROVEMENT AND DISTRIBUTING OF TRAINING MATERIALS SUCH AS DVDS, TECH MANUALS AND BOOKS; EDUCATION SERVICES, NAMELY, PROVIDING CAREER RE-TRAINING LIVE AND ON-LINE CLASSES, SEMINARS, WORKSHOPS, AND DISTRIBUTING OF TRAINING MATERIALS SUCH AS DVDS, TECH MANUALS IN THE FIELDS OF DECORATIVE CONCRETE, HOME IMPROVEMENT, ART, CONTRACTING, PERSONAL IMPROVEMENT, HEALTH AND FITNESS, GENERAL TRADES, PRODUCTION TRADES, BUSINESS AND DIY HOME IMPROVEMENT; EDUCATION SERVICES, NAMELY, PROVIDING LIVE AND ON-LINE LIVE AND ONLINE CLASSES, SEMINARS, WORKSHOPS, AND DISTRIBUTING OF TRAINING MATERIALS SUCH AS DVDS, TECH MANUALS AND BOOKS IN THE FIELD OF DECORATIVE CONCRETE, HOME IMPROVEMENT, ART, CONTRACTING, PERSONAL IMPROVEMENT, HEALTH AND FITNESS, GENERAL TRADES, PRODUCTION TRADES, BUSINESS AND DIY HOME IMPROVEMENT; EDUCATION SERVICES, NAMELY, PROVIDING MENTORING, TUTORING, CLASSES, SEMINARS AND WORKSHOPS IN THE FIELD OF DECORATIVE CONCRETE, HOME IMPROVEMENT, ART, CONTRACTING, PERSONAL IMPROVEMENT, HEALTH AND FITNESS, GENERAL TRADES, PRODUCTION TRADES, BUSINESS AND DIY HOME IMPROVEMENT AND DISTRIBUTING OF TRAINING MATERIALS SUCH AS DVDS, TECH MANUALS; EDUCATION SERVICES, NAMELY, PROVIDING ON-LINE LIVE AND ONLINE CLASSES, SEMINARS, WORKSHOPS, AND DISTRIBUTING OF TRAINING MATERIALS SUCH AS DVDS, TECH MANUALS IN THE FIELD OF DECORATIVE CONCRETE, HOME IMPROVEMENT, ART, CONTRACTING, PERSONAL IMPROVEMENT, HEALTH AND FITNESS, GENERAL TRADES, PRODUCTION TRADES, BUSINESS AND DIY HOME IMPROVEMENT.

CLASS 41—(Continued).

TRADES, PRODUCTION TRADES, BUSINESS AND DIY HOME IMPROVEMENT; EDUCATION SERVICES, NAMELY, PROVIDING TUTORIAL SESSIONS IN THE FIELDS OF DECORATIVE CONCRETE, HOME IMPROVEMENT, ART, CONTRACTING, PERSONAL IMPROVEMENT, HEALTH AND FITNESS, GENERAL TRADES, PRODUCTION TRADES, BUSINESS AND DIY HOME IMPROVEMENT; EDUCATION SERVICES, NAMELY, PROVIDING LIVE AND ONLINE CLASSES, SEMINARS, WORKSHOPS, AND DISTRIBUTING OF TRAINING MATERIALS SUCH AS DVDS, TECH MANUALS IN THE FIELDS OF DECORATIVE CONCRETE, HOME IMPROVEMENT, ART, CONTRACTING, PERSONAL IMPROVEMENT, HEALTH AND FITNESS, GENERAL TRADES, PRODUCTION TRADES, BUSINESS AND DIY HOME IMPROVEMENT; EDUCATIONAL AND ENTERTAINMENT SERVICES, NAMELY, A CONTINUING PROGRAM ABOUT DECORATIVE CONCRETE, HOME IMPROVEMENT, ART, CONTRACTING, PERSONAL IMPROVEMENT, HEALTH AND FITNESS, GENERAL TRADES, PRODUCTION TRADES, BUSINESS AND DIY HOME IMPROVEMENT ACCESSIBLE BY RADIO, TELEVISION, SATELLITE, AUDIO, VIDEO AND COMPUTER NETWORKS AND DISTRIBUTING OF TRAINING MATERIALS SUCH AS DVDS, TECH MANUALS; EDUCATIONAL AND ENTERTAINMENT SERVICES, NAMELY, PROVIDING MOTIVATIONAL AND EDUCATIONAL SPEAKERS IN THE FIELD OF SELF- AND PERSONAL IMPROVEMENT AND DISTRIBUTING OF TRAINING MATERIALS SUCH AS DVDS, TECH MANUALS; EDUCATIONAL AND ENTERTAINMENT SERVICES, NAMELY, PROVIDING MOTIVATIONAL SPEAKING SERVICES IN THE FIELD OF DECORATIVE CONCRETE, HOME IMPROVEMENT, ART, CONTRACTING, PERSONAL IMPROVEMENT, HEALTH AND FITNESS, GENERAL TRADES, PRODUCTION TRADES, BUSINESS AND DIY HOME IMPROVEMENT AND DISTRIBUTING OF TRAINING MATERIALS SUCH AS DVDS, TECH MANUALS; EDUCATIONAL SERVICES, NAMELY, CONDUCTING DISTANCE LEARNING INSTRUCTION AT THE SECONDARY, COLLEGE AND GRADUATE LEVELS AND DISTRIBUTING OF TRAINING MATERIALS SUCH AS DVDS, TECH MANUALS; EDUCATIONAL SERVICES, NAMELY, CONDUCTING INFORMAL ON-LINE PROGRAMS IN THE FIELDS OF DECORATIVE CONCRETE, HOME IMPROVEMENT, ART, CONTRACTING, PERSONAL IMPROVEMENT, HEALTH AND FITNESS, GENERAL TRADES, PRODUCTION TRADES, BUSINESS AND DIY HOME IMPROVEMENT, AND PRINTABLE MATERIALS DISTRIBUTED THEREWITH AND DISTRIBUTING OF TRAINING MATERIALS SUCH AS DVDS, TECH MANUALS; EDUCATIONAL SERVICES, NAMELY, CONDUCTING ON LINE AND TELEPHONIC INSTRUCTION AND COURSES IN THE FIELD OF DECORATIVE CONCRETE, HOME IMPROVEMENT, ART, CONTRACTING, PERSONAL IMPROVEMENT, HEALTH AND FITNESS, GENERAL TRADES, PRODUCTION TRADES, BUSINESS AND DIY HOME IMPROVEMENT AND DISTRIBUTING OF TRAINING MATERIALS SUCH AS DVDS, TECH MANUALS; EDUCATIONAL SERVICES, NAMELY, CONDUCTING PROGRAMS IN THE FIELD OF DECORATIVE CONCRETE, HOME IMPROVEMENT, ART, CONTRACTING, PERSONAL IMPROVEMENT, HEALTH AND FITNESS, GENERAL TRADES, PRODUCTION TRADES, BUSINESS AND DIY HOME IMPROVEMENT AND DISTRIBUTING OF TRAINING MATERIALS SUCH AS DVDS, TECH MANUALS; EDUCATIONAL SERVICES, NAMELY, CONDUCTING LIVE AND ONLINE CLASSES, SEMINARS, WORKSHOPS, TRAINING DVDS, TRAINING VIDEOS, ONLINE TRAINING, BOOKS AND TECH MANUALS IN

CLASS 41—(Continued).

THE FIELDS OF DECORATIVE CONCRETE, HOME IMPROVEMENT, ART, CONTRACTING, PERSONAL IMPROVEMENT, HEALTH AND FITNESS, GENERAL TRADES, PRODUCTION TRADES, BUSINESS AND DIY HOME IMPROVEMENT AND DISTRIBUTION OF TRAINING MATERIALS IN CONNECTION THEREWITH AND DISTRIBUTING OF TRAINING MATERIALS SUCH AS DVDS, TECH MANUALS; EDUCATIONAL SERVICES, NAMELY, CONDUCTING LIVE AND ONLINE CLASSES, SEMINARS, WORKSHOPS, TRAINING DVDS, TRAINING VIDEOS, ONLINE TRAINING, BOOKS AND TECH MANUALS IN THE FIELD OF DECORATIVE CONCRETE, HOME IMPROVEMENT, ART, CONTRACTING, PERSONAL IMPROVEMENT, HEALTH AND FITNESS, GENERAL TRADES, PRODUCTION TRADES, BUSINESS AND DIY HOME IMPROVEMENT AND DISTRIBUTING OF TRAINING MATERIALS SUCH AS DVDS, TECH MANUALS; EDUCATIONAL SERVICES, NAMELY, CONDUCTING LIVE AND ONLINE CLASSES, SEMINARS, WORKSHOPS, TRAINING DVDS, TRAINING VIDEOS, ONLINE TRAINING, BOOKS AND TECH MANUALS IN THE FIELD OF DECORATIVE CONCRETE, HOME IMPROVEMENT, ART, CONTRACTING, PERSONAL IMPROVEMENT, HEALTH AND FITNESS, GENERAL TRADES, PRODUCTION TRADES, BUSINESS AND DIY HOME IMPROVEMENT AND DISTRIBUTION OF PRINTED MATERIALS IN CONNECTION THEREWITH IN HARD COPY OR ELECTRONIC FORMAT ON THE SAME TOPICS AND DISTRIBUTING OF TRAINING MATERIALS SUCH AS DVDS, TECH MANUALS; EDUCATIONAL SERVICES, NAMELY, CONDUCTING LIVE AND ONLINE CLASSES, SEMINARS, WORKSHOPS, AND DISTRIBUTING OF TRAINING MATERIALS SUCH AS DVDS, TECH MANUALS IN THE FIELD OF DECORATIVE CONCRETE, HOME IMPROVEMENT, ART, CONTRACTING, PERSONAL IMPROVEMENT, HEALTH AND FITNESS, GENERAL TRADES, PRODUCTION TRADES, BUSINESS AND DIY HOME IMPROVEMENT AND DISTRIBUTION OF COURSE MATERIAL IN CONNECTION THEREWITH; EDUCATIONAL SERVICES, NAMELY, CONDUCTING LIVE AND ONLINE CLASSES, SEMINARS, WORKSHOPS, AND DISTRIBUTING OF TRAINING MATERIALS SUCH AS DVDS, TECH MANUALS IN THE FIELD OF DECORATIVE CONCRETE, HOME IMPROVEMENT, ART, CONTRACTING, PERSONAL IMPROVEMENT, HEALTH AND FITNESS, GENERAL TRADES, PRODUCTION TRADES, BUSINESS AND DIY HOME IMPROVEMENT AND DISTRIBUTION OF TRAINING MATERIAL IN CONNECTION THEREWITH; EDUCATIONAL SERVICES, NAMELY, DEVELOPING ANIMATION BASED INSTRUCTIONS FOR OTHERS IN THE FIELD OF CONSUMER OR MANUFACTURING HOW-TO PROCEDURES AND DISTRIBUTING OF TRAINING MATERIALS SUCH AS DVDS, TECH MANUALS; EDUCATIONAL SERVICES, NAMELY, DEVELOPING CURRICULUM FOR OTHERS IN THE FIELD OF DECORATIVE CONCRETE, HOME IMPROVEMENT, ART, CONTRACTING, PERSONAL IMPROVEMENT, HEALTH AND FITNESS, GENERAL TRADES, PRODUCTION TRADES, BUSINESS AND DIY HOME IMPROVEMENT AND DISTRIBUTING OF TRAINING MATERIALS SUCH AS DVDS, TECH MANUALS; EDUCATIONAL SERVICES, NAMELY, DEVELOPING, ARRANGING, AND CONDUCTING EDUCATIONAL CONFERENCES AND PROGRAMS AND PROVIDING COURSES OF INSTRUCTION IN THE FIELD OF DECORATIVE CONCRETE, HOME IMPROVEMENT, ART, CONTRACTING, PERSONAL IMPROVEMENT, HEALTH AND FITNESS, GENERAL TRADES, PRODUCTION TRADES, BUSINESS AND DIY HOME IMPROVEMENT AND DISTRIBUTING OF TRAINING MATERIALS SUCH AS DVDS, TECH MANUALS; EDUCATIONAL SERVICES, NAMELY, PROVIDING CONTINUING PROFESSIONAL EDUCATION COURSES IN THE FIELD OF DECORATIVE CONCRETE, HOME IMPROVEMENT, ART, CONTRACTING, PERSONAL IMPROVEMENT, HEALTH AND FITNESS, GENERAL TRADES, PRODUCTION TRADES, BUSINESS AND DIY HOME IMPROVEMENT AND DISTRIBUTING OF TRAINING MATERIALS SUCH AS DVDS, TECH MANUALS; EDUCATIONAL SERVICES, NAMELY, PROVIDING EDUCATIONAL SPEAKERS IN THE FIELD OF DECORATIVE CONCRETE, HOME

CLASS 41—(Continued).

IMPROVEMENT, ART, CONTRACTING, PERSONAL IMPROVEMENT, HEALTH AND FITNESS, GENERAL TRADES, PRODUCTION TRADES, BUSINESS AND DIY HOME IMPROVEMENT AND DISTRIBUTING OF TRAINING MATERIALS SUCH AS DVDS, TECH MANUALS; PROVIDING ASSISTANCE, PERSONAL TRAINING AND PHYSICAL FITNESS CONSULTATION TO INDIVIDUALS TO HELP THEM MAKE PHYSICAL FITNESS, STRENGTH, CONDITIONING, AND EXERCISE IMPROVEMENT IN THEIR DAILY LIVING AND DISTRIBUTING OF TRAINING MATERIALS SUCH AS DVDS, TECH MANUALS (U.S. CLS. 100, 101 AND 107).
KIMBERLY PERRY, EXAMINING ATTORNEY

SN 85-202,756. CHOI, JUNG KI, KATY, TX. AND CHOI, WHAN KI, KATY, TX. FILED 12-21-2010.



NO CLAIM IS MADE TO THE EXCLUSIVE RIGHT TO USE "HAPKIDO ASSOCIATION" AND THE NON-LATIN CHARACTERS THAT TRANSLITERATE TO "HAP KI DO", APART FROM THE MARK AS SHOWN.

THE COLOR(S) BLUE, RED, YELLOW, BLACK, GRAY AND WHITE IS/ARE CLAIMED AS A FEATURE OF THE MARK.

THE MARK CONSISTS OF THE "UMA HAPKIDO ASSOCIATION" LOGO HAVING A YELLOW CIRCLE OF MINIMAL THICKNESS ENCOMPASSING A THICKER BLUE CIRCLE WITH THE WORDS "UMA HAPKIDO ASSOCIATION" IN WHITE LOCATED IN A SEMICIRCLE FASHION AT THE TOP HALF OF THE BLUE CIRCLE. A YELLOW STAR IS LOCATED APPROXIMATELY 2 LETTER LENGTHS BEFORE "UMA" AND AFTER "ASSOCIATION". THREE KOREAN CHARACTERS IN WHITE ARE THAN LOCATED AT THE BOTTOM CENTER OF THE BLUE CIRCLE. A THIN WHITE CIRCLE ENCIRCLES A "YIN-YANG" TYPE CIRCLE WITH RED COLOR WITHIN THE YIN AND BLUE COLOR WITHIN THE YANG. A WHITE BOUNDARY LINE SEPARATES THE YIN FROM THE YANG. AN EAGLE IN GRAY COLOR, OUTLINED IN BLACK, WITH A WHITE HEAD WITH TWO OPEN WINGS AND IN ATTACK POSITION IS PLACED IN THE MIDDLE OF THIS YIN-YANG.

THE NON-LATIN CHARACTERS IN THE MARK TRANSLITERATE TO "HAP KI DO" AND THIS MEANS "HAPKIDO" IN ENGLISH.

FOR OPERATING OF MARTIAL ARTS' SCHOOLS; ORGANIZING LIVE MIXED MARTIAL ARTS EVENTS AND COMPETITIONS; PRESENTATION OF MIXED MARTIAL ARTS (MMA) EVENTS; PROVIDING CLASSES, WORKSHOPS, SEMINARS AND CAMPS IN THE FIELDS OF FITNESS, EXERCISE, BOXING, KICK BOXING AND MIXED MARTIAL ARTS; PROVIDING GENERAL FITNESS AND MIXED MARTIAL ARTS FACILITIES THAT REQUIRE MEMBERSHIPS AND ARE FOCUSED IN THE FIELDS OF GENERAL FITNESS, EXERCISE, AND MIXED MARTIAL ARTS (U.S. CLS. 100, 101 AND 107).

FIRST USE 1-1-1973; IN COMMERCE 1-1-1973.
JOHN SCHUYLER YARD, EXAMINING ATTORNEY

CLASS 41—(Continued).

SN 85-206,187. ZYNGA INC., SAN FRANCISCO, CA. FILED 12-27-2010.



THE MARK CONSISTS OF THE STYLIZED LETTER "C" AND THE STYLIZED LETTER "V" WITH THE TOP PORTION OF THE LETTER "C" SLIGHTLY OVERLAPPING THE TOP PORTION OF THE LETTER "V".

FOR PROVIDING ONLINE COMPUTER AND ELECTRONIC GAMES; PROVIDING ONLINE REVIEWS OF COMPUTER GAMES; PROVIDING ONLINE INFORMATION RELATING TO COMPUTER GAMES; PROVIDING AN INTERNET WEBSITE PORTAL IN THE FIELD OF COMPUTER GAMES AND ONLINE GAMING; PROVIDING VIRTUAL ENVIRONMENTS IN WHICH USERS CAN INTERACT THROUGH SOCIAL GAMES FOR RECREATIONAL, LEISURE OR ENTERTAINMENT PURPOSES (U.S. CLS. 100, 101 AND 107).

FIRST USE 12-2-2010; IN COMMERCE 12-2-2010.
CHRISTOPHER BUONGIORNO, EXAMINING ATTORNEY

SN 85-217,908. GOODLIFE MANAGEMENT LLC, HOUSTON, TX. FILED 1-14-2011.

OUR LEGENDS CIGAR BAR

THE MARK CONSISTS OF STANDARD CHARACTERS WITHOUT CLAIM TO ANY PARTICULAR FONT, STYLE, SIZE, OR COLOR.

NO CLAIM IS MADE TO THE EXCLUSIVE RIGHT TO USE "CIGAR BAR", APART FROM THE MARK AS SHOWN. FOR CIGAR LOUNGE SERVICES (U.S. CLS. 100, 101 AND 107).

FIRST USE 8-25-2010; IN COMMERCE 8-25-2010.
IRA J. GOODSaid, EXAMINING ATTORNEY

CLASS 41—(Continued).

SN 85-261,565. BLACKSTONE MORTGAGE HOLDINGS, LLC, GUTHRIE, OK. FILED 3-8-2011.

Cosmic Jump

THE MARK CONSISTS OF STANDARD CHARACTERS WITHOUT CLAIM TO ANY PARTICULAR FONT, STYLE, SIZE, OR COLOR.

NO CLAIM IS MADE TO THE EXCLUSIVE RIGHT TO USE "JUMP", APART FROM THE MARK AS SHOWN.

FOR EXERCISE AND RECREATION FACILITIES (U.S. CLS. 100, 101 AND 107).

JACLYN KIDWELL WALKER, EXAMINING ATTORNEY



SN 85-264,098. HOLDER, EARL, HEMPSTEAD, NY. FILED 3-11-2011.

PERIPHERAL ENTERPRISES, LLC

THE MARK CONSISTS OF STANDARD CHARACTERS WITHOUT CLAIM TO ANY PARTICULAR FONT, STYLE, SIZE, OR COLOR.

NO CLAIM IS MADE TO THE EXCLUSIVE RIGHT TO USE "ENTERPRISES, LLC", APART FROM THE MARK AS SHOWN.

FOR ENTERTAINMENT AND RECORD LABEL SERVICES, NAMELY, MUSIC SONGWRITING, RECORDING, PRODUCTION AND PUBLISHING, MUSIC VIDEO CREATION AND PRODUCTION, MUSIC PUBLISHING, FILM DISTRIBUTION, ARRANGING AND CONDUCTING OF CONCERTS; ORGANIZING EVENTS FEATURING LIVE MUSICAL PERFORMANCES; FILM AND VIDEO FILM PRODUCTION; MOTION PICTURE FILM PRODUCTION; DISTRIBUTION OF MOTION PICTURE FILMS; MULTIMEDIA ENTERTAINMENT SERVICES IN THE NATURE OF DEVELOPMENT, PRODUCTION AND POST-PRODUCTION SERVICES IN THE FIELDS OF MUSIC, VIDEO AND FILMS; DISTRIBUTION OF TELEVISION PROGRAMS FOR OTHERS; ENTERTAINMENT MEDIA PRODUCTION SERVICES FOR MOTION PICTURES, TELEVISION AND INTERNET; PRODUCTION OF TELEVISION PROGRAMS; TELEVISION, VIDEO AND MOVIE FILMING SERVICES (U.S. CLS. 100, 101 AND 107).

JANICE KIM, EXAMINING ATTORNEY

CLASS 41—(Continued).

SN 85-272,374. SOULJAH STORY, INC., NEW YORK, NY. FILED 3-21-2011.

SISTER SOULJAH

THE MARK CONSISTS OF STANDARD CHARACTERS WITHOUT CLAIM TO ANY PARTICULAR FONT, STYLE, SIZE, OR COLOR.

"SISTER SOULJAH" IDENTIFIES THE STAGE NAME AND PSEUDONYM OF LISA WILLIAMSON, A LIVING INDIVIDUAL WHOSE CONSENT IS OF RECORD.

FOR ENTERTAINMENT IN THE NATURE OF LIVE DRAMATIC, COMEDIC, MUSICAL AND SPOKEN WORD PERFORMANCES; ENTERTAINMENT SERVICES, NAMELY, LIVE, TELEVISED AND MOVIE APPEARANCES BY A PROFESSIONAL ENTERTAINER; PUBLISHING OF BOOKS, MAGAZINES, REVIEWS; PUBLISHING OF JOURNALS, BOOKS AND HANDBOOKS IN THE FIELD OF MEDICINE (U.S. CLS. 100, 101 AND 107).

FIRST USE 0-0-1989; IN COMMERCE 0-0-1989.

REGINA DRUMMOND, EXAMINING ATTORNEY



SN 85-284,830. CONFIDENTIAL CONCEPTS, INC., DOVER, DE. FILED 4-4-2011.

SIRROCCO PUBLISHING

THE MARK CONSISTS OF STANDARD CHARACTERS WITHOUT CLAIM TO ANY PARTICULAR FONT, STYLE, SIZE, OR COLOR.

NO CLAIM IS MADE TO THE EXCLUSIVE RIGHT TO USE "PUBLISHING", APART FROM THE MARK AS SHOWN.

THE WORDING "SIRROCCO" HAS NO MEANING IN A FOREIGN LANGUAGE.

FOR PUBLICATION OF BOOKS; PUBLICATION OF ELECTRONIC BOOKS AND JOURNALS ON-LINE; MULTIMEDIA PUBLISHING OF BOOKS, MAGAZINES, JOURNALS, SOFTWARE, GAMES, MUSIC, AND ELECTRONIC PUBLICATIONS (U.S. CLS. 100, 101 AND 107).

FIRST USE 1-1-2000; IN COMMERCE 1-1-2000.

KIMBERLY FRYE, EXAMINING ATTORNEY

CLASS 41—(Continued).

SN 85-288,193. FANTASY FOR REALITY, LLC, CHICAGO, IL. FILED 4-6-2011.

FANTASY4REALITY

THE MARK CONSISTS OF STANDARD CHARACTERS WITHOUT CLAIM TO ANY PARTICULAR FONT, STYLE, SIZE, OR COLOR.

FOR ENTERTAINMENT SERVICES IN THE NATURE OF TELEVISION GAME SHOWS AND REALITY-BASED TELEVISION SHOWS FEATURING COMPETITIONS; PROVIDING A WEBSITE FEATURING ENTERTAINMENT INFORMATION ON TELEVISION SHOWS, TELEVISION GAME SHOWS, AND REALITY-BASED TELEVISION SHOWS FEATURING COMPETITIONS; ENTERTAINMENT SERVICES, NAMELY, PROVIDING ON-LINE GAMES BASED ON TELEVISION GAME SHOWS AND REALITY-BASED TELEVISION SHOWS FEATURING COMPETITIONS (U.S. CLS. 100, 101 AND 107).

STEVEN R. FINE, EXAMINING ATTORNEY

SN 85-291,857. THE JIM HENSON COMPANY, INC., LOS ANGELES, CA. FILED 4-11-2011.

THE POSSIBILITY SHOP

THE MARK CONSISTS OF STANDARD CHARACTERS WITHOUT CLAIM TO ANY PARTICULAR FONT, STYLE, SIZE, OR COLOR.

FOR ENTERTAINMENT SERVICES, NAMELY, PROVIDING ONGOING WEBISODES FEATURING CREATIVE AND INSPIRATIONAL ACTIVITIES FOR CHILDREN AND FAMILIES, CRAFTS, AND FOOD AND MEAL TIPS VIA A GLOBAL COMPUTER NETWORK; PRODUCING WEBISODES FEATURING FAMILY AND CHILDREN'S ENTERTAINMENT AND ACTIVITIES; PROVIDING A WEBSITE FEATURING NON-DOWNLOADABLE VIDEO CLIPS FEATURING CHILDREN'S AND FAMILY ENTERTAINMENT AND CREATIVE LEARNING ACTIVITIES FOR CHILDREN AND FAMILIES, CRAFT ACTIVITIES, AND INFORMATION ON RELATED WEBISODES; AND NON-DOWNLOADABLE ACTIVITY GUIDES FEATURING CRAFTS, RECREATIONAL, LEISURE, ENTERTAINMENT, AND CREATIVE AND LEARNING ACTIVITIES FOR CHILDREN AND FAMILY (U.S. CLS. 100, 101 AND 107).

FIRST USE 0-0-2009; IN COMMERCE 0-0-2009.
JUDITH HELFMAN, EXAMINING ATTORNEY

CLASS 41—(Continued).

SN 85-294,903. HEALTHCARE INFORMATION AND MANAGEMENT SYSTEMS SOCIETY, CHICAGO, IL. FILED 4-14-2011.

THE JOURNAL OF HEALTHCARE INFORMATION MANAGEMENT

THE MARK CONSISTS OF STANDARD CHARACTERS WITHOUT CLAIM TO ANY PARTICULAR FONT, STYLE, SIZE, OR COLOR.

OWNER OF U.S. REG. NOS. 1,650,487 AND 1,714,415.

NO CLAIM IS MADE TO THE EXCLUSIVE RIGHT TO USE "JOURNAL", APART FROM THE MARK AS SHOWN.

SEC. 2(F) AS TO "HEALTHCARE INFORMATION MANAGEMENT".

FOR ON-LINE JOURNALS, NAMELY, MAGAZINES CONCERNING TOPICS OF INTEREST TO PROFESSIONALS IN THE FIELDS OF INFORMATION SYSTEMS, MANAGEMENT ENGINEERING, AND TELECOMMUNICATIONS, ALL IN THE HEALTH CARE INDUSTRY (U.S. CLS. 100, 101 AND 107).

FIRST USE 10-0-2007; IN COMMERCE 10-0-2007.

WILLIAM VERHOSEK, EXAMINING ATTORNEY

SN 85-295,748. DISNEY ENTERPRISES, INC., BURBANK, CA. FILED 4-14-2011.

TINKER BELL

THE MARK CONSISTS OF STANDARD CHARACTERS WITHOUT CLAIM TO ANY PARTICULAR FONT, STYLE, SIZE, OR COLOR.

FOR PRODUCTION, PRESENTATION, DISTRIBUTION, AND RENTAL OF MOTION PICTURE FILMS; PRODUCTION, PRESENTATION AND DISTRIBUTION OF TELEVISION AND RADIO PROGRAMS; PRODUCTION, PRESENTATION, DISTRIBUTION, AND RENTAL OF SOUND AND VISUAL RECORDINGS; PRODUCTION AND PROVISION OF ENTERTAINMENT IN THE FIELDS OF LIVE-ACTION ENTERTAINMENT, ANIMATED ENTERTAINMENT, MUSIC, STORIES, ACTIVITIES AND GAMES VIA COMMUNICATION NETWORKS; PROVISION OF ENTERTAINMENT NEWS AND INFORMATION VIA COMMUNICATION NETWORKS; PROVISION OF ONLINE ELECTRONIC, VIDEO AND COMPUTER GAMES; AMUSEMENT PARK AND THEME PARK SERVICES; EDUCATIONAL AND ENTERTAINMENT SERVICES RENDERED IN OR RELATING TO THEME PARKS, NAMELY, LIVE STAGE SHOWS, LIVE AMUSEMENT PARK SHOWS, LIVE PERFORMANCES BY COSTUMED CHARACTERS, AND PRESENTATION OF LIVE THEATRICAL PERFORMANCES; PRESENTATION OF LIVE STAGE SHOWS; PRESENTATION OF LIVE SHOW PERFORMANCES; THEATER PRODUCTIONS; ENTERTAINER SERVICES, NAMELY, LIVE APPEARANCES BY A PROFESSIONAL ENTERTAINER (U.S. CLS. 100, 101 AND 107).

NAKWAMA ANKRAH, EXAMINING ATTORNEY

CLASS 41—(Continued).

SN 85-296,797. FLEXEDGE GAMING, LLC, HUNTINGTON BEACH, CA. FILED 4-15-2011.



NO CLAIM IS MADE TO THE EXCLUSIVE RIGHT TO USE "BACCARAT", APART FROM THE MARK AS SHOWN. THE MARK CONSISTS OF THE WORDS "SUPREME BACCARAT" IN STYLIZED FORMAY WHEREIN THE LETTER "S" OF THE WORD "SUPREME" APPEARS AS A STYLIZED DRAGON.

FOR ENTERTAINMENT IN THE NATURE OF CONDUCTING LIVE BACCARAT GAMES; ENTERTAINMENT SERVICES, NAMELY, CASINO GAMING; ENTERTAINMENT SERVICES, NAMELY, PROVIDING AN ON-LINE COMPUTER GAME; GAMING SERVICES IN THE NATURE OF CASINO GAMING; LEASING OF CASINO GAMES; LEASING OF ELECTRONIC GAMING MACHINES (U.S. CLS. 100, 101 AND 107).

JAMES A. RAUEN, EXAMINING ATTORNEY

SN 85-298,068. DISNEY ENTERPRISES, INC., BURBANK, CA. FILED 4-18-2011.

LADY AND THE TRAMP

THE MARK CONSISTS OF STANDARD CHARACTERS WITHOUT CLAIM TO ANY PARTICULAR FONT, STYLE, SIZE, OR COLOR.

FOR PRODUCTION, PRESENTATION, DISTRIBUTION, AND RENTAL OF MOTION PICTURE FILMS; PRODUCTION, PRESENTATION AND DISTRIBUTION OF TELEVISION AND RADIO PROGRAMS; PRODUCTION, PRESENTATION, DISTRIBUTION, AND RENTAL OF SOUND AND VISUAL RECORDINGS; PRODUCTION AND PROVISION OF ENTERTAINMENT IN THE FIELDS OF LIVE-ACTION ENTERTAINMENT, ANIMATED ENTERTAINMENT, MUSIC, STORIES, ACTIVITIES AND GAMES VIA COMMUNICATION NETWORKS; PROVISION OF ENTERTAINMENT NEWS AND INFORMATION VIA COMMUNICATION NETWORKS; PROVISION OF ONLINE ELECTRONIC, VIDEO AND COMPUTER GAMES; AMUSEMENT PARK AND THEME PARK SERVICES; EDUCATIONAL AND ENTERTAINMENT SERVICES RENDERED IN OR RELATING TO THEME PARKS, NAMELY, LIVE STAGE SHOWS, LIVE AMUSEMENT PARK SHOWS, LIVE PERFORMANCES BY COSTUMED CHARACTERS, AND PRESENTATION OF LIVE THEATRICAL PERFORMANCES; PRESENTATION OF LIVE STAGE SHOWS; PRESENTATION OF LIVE SHOW PERFORMANCES; THEATER PRODUCTIONS; ENTERTAINER SERVICES, NAMELY, LIVE APPEARANCES BY A PROFESSIONAL ENTERTAINER (U.S. CLS. 100, 101 AND 107).

NAKWAMA ANKRAH, EXAMINING ATTORNEY

CLASS 41—(Continued).

SN 85-298,071. DISNEY ENTERPRISES, INC., BURBANK, CA. FILED 4-18-2011.

CRUELLA DE VIL

THE MARK CONSISTS OF STANDARD CHARACTERS WITHOUT CLAIM TO ANY PARTICULAR FONT, STYLE, SIZE, OR COLOR.

THE NAME(S), PORTRAIT(S), AND/OR SIGNATURE(S) SHOWN IN THE MARK DOES NOT IDENTIFY A PARTICULAR LIVING INDIVIDUAL.

FOR PRODUCTION, PRESENTATION, DISTRIBUTION, AND RENTAL OF MOTION PICTURE FILMS; PRODUCTION, PRESENTATION AND DISTRIBUTION OF TELEVISION AND RADIO PROGRAMS; PRODUCTION, PRESENTATION, DISTRIBUTION, AND RENTAL OF SOUND AND VISUAL RECORDINGS; PRODUCTION AND PROVISION OF ENTERTAINMENT IN THE FIELDS OF LIVE-ACTION ENTERTAINMENT, ANIMATED ENTERTAINMENT, MUSIC, STORIES, ACTIVITIES AND GAMES VIA COMMUNICATION NETWORKS; PROVISION OF ENTERTAINMENT NEWS AND INFORMATION VIA COMMUNICATION NETWORKS; PROVISION OF ONLINE ELECTRONIC, VIDEO AND COMPUTER GAMES; AMUSEMENT PARK AND THEME PARK SERVICES; EDUCATIONAL AND ENTERTAINMENT SERVICES RENDERED IN OR RELATING TO THEME PARKS, NAMELY, LIVE STAGE SHOWS, LIVE AMUSEMENT PARK SHOWS, LIVE PERFORMANCES BY COSTUMED CHARACTERS, AND PRESENTATION OF LIVE THEATRICAL PERFORMANCES; PRESENTATION OF LIVE STAGE SHOWS; PRESENTATION OF LIVE SHOW PERFORMANCES; THEATER PRODUCTIONS; ENTERTAINER SERVICES, NAMELY, LIVE APPEARANCES BY A PROFESSIONAL ENTERTAINER (U.S. CLS. 100, 101 AND 107).

NAKWAMA ANKRAH, EXAMINING ATTORNEY

CLASS 41—(Continued).

SN 85-298,074. DISNEY ENTERPRISES, INC., BURBANK, CA. FILED 4-18-2011.

JIMINY CRICKET

THE MARK CONSISTS OF STANDARD CHARACTERS WITHOUT CLAIM TO ANY PARTICULAR FONT, STYLE, SIZE, OR COLOR.

FOR PRODUCTION, PRESENTATION, DISTRIBUTION, AND RENTAL OF MOTION PICTURE FILMS; PRODUCTION, PRESENTATION AND DISTRIBUTION OF TELEVISION AND RADIO PROGRAMS; PRODUCTION, PRESENTATION, DISTRIBUTION, AND RENTAL OF SOUND AND VISUAL RECORDINGS; PRODUCTION AND PROVISION OF ENTERTAINMENT IN THE FIELDS OF LIVE-ACTION ENTERTAINMENT, ANIMATED ENTERTAINMENT, MUSIC, STORIES, ACTIVITIES AND GAMES VIA COMMUNICATION NETWORKS; PROVISION OF ENTERTAINMENT NEWS AND INFORMATION VIA COMMUNICATION NETWORKS; PROVISION OF ONLINE ELECTRONIC, VIDEO AND COMPUTER GAMES; AMUSEMENT PARK AND THEME PARK SERVICES; EDUCATIONAL AND ENTERTAINMENT SERVICES RENDERED IN OR RELATING TO THEME PARKS, NAMELY, LIVE STAGE SHOWS, LIVE AMUSEMENT PARK SHOWS, LIVE PERFORMANCES BY COSTUMED CHARACTERS, AND PRESENTATION OF LIVE THEATRICAL PERFORMANCES; PRESENTATION OF LIVE STAGE SHOWS; PRESENTATION OF LIVE SHOW PERFORMANCES; THEATER PRODUCTIONS; ENTERTAINER SERVICES, NAMELY, LIVE APPEARANCES BY A PROFESSIONAL ENTERTAINER (U.S. CLS. 100, 101 AND 107).

NAAKWAMA ANKRAH, EXAMINING ATTORNEY

CLASS 41—(Continued).

SN 85-298,076. DISNEY ENTERPRISES, INC., BURBANK, CA. FILED 4-18-2011.

MALEFICENT

THE MARK CONSISTS OF STANDARD CHARACTERS WITHOUT CLAIM TO ANY PARTICULAR FONT, STYLE, SIZE, OR COLOR.

FOR PRODUCTION, PRESENTATION, DISTRIBUTION, AND RENTAL OF MOTION PICTURE FILMS; PRODUCTION, PRESENTATION AND DISTRIBUTION OF TELEVISION AND RADIO PROGRAMS; PRODUCTION, PRESENTATION, DISTRIBUTION, AND RENTAL OF SOUND AND VISUAL RECORDINGS; PRODUCTION AND PROVISION OF ENTERTAINMENT IN THE FIELDS OF LIVE-ACTION ENTERTAINMENT, ANIMATED ENTERTAINMENT, MUSIC, STORIES, ACTIVITIES AND GAMES VIA COMMUNICATION NETWORKS; PROVISION OF ENTERTAINMENT NEWS AND INFORMATION VIA COMMUNICATION NETWORKS; PROVISION OF ONLINE ELECTRONIC, VIDEO AND COMPUTER GAMES; AMUSEMENT PARK AND THEME PARK SERVICES; EDUCATIONAL AND ENTERTAINMENT SERVICES RENDERED IN OR RELATING TO THEME PARKS, NAMELY, LIVE STAGE SHOWS, LIVE AMUSEMENT PARK SHOWS, LIVE PERFORMANCES BY COSTUMED CHARACTERS, AND PRESENTATION OF LIVE THEATRICAL PERFORMANCES; PRESENTATION OF LIVE STAGE SHOWS; PRESENTATION OF LIVE SHOW PERFORMANCES; THEATER PRODUCTIONS; ENTERTAINER SERVICES, NAMELY, LIVE APPEARANCES BY A PROFESSIONAL ENTERTAINER (U.S. CLS. 100, 101 AND 107).

NAAKWAMA ANKRAH, EXAMINING ATTORNEY

SN 85-298,200. COASTAL LUXURY MANAGEMENT, LLC, DBA LOS ANGELES FOOD & WINE, MONTEREY, CA. FILED 4-18-2011.

LOS ANGELES
FOOD & WINE

THE MARK CONSISTS OF STANDARD CHARACTERS WITHOUT CLAIM TO ANY PARTICULAR FONT, STYLE, SIZE, OR COLOR.

NO CLAIM IS MADE TO THE EXCLUSIVE RIGHT TO USE "FOOD & WINE", APART FROM THE MARK AS SHOWN.

SEC. 2(F).

FOR ENTERTAINMENT SERVICES, NAMELY, WINE AND FOOD TASTINGS (U.S. CLS. 100, 101 AND 107).

FIRST USE 10-13-2011; IN COMMERCE 10-13-2011.

ALYSSA STEEL, EXAMINING ATTORNEY

CLASS 41—(Continued).

SN 85-298,212. COASTAL LUXURY MANAGEMENT, LLC,
DBA LOS ANGELES FOOD & WINE, MONTEREY, CA.
FILED 4-18-2011.

LOS ANGELES FOOD & WINE

NO CLAIM IS MADE TO THE EXCLUSIVE RIGHT TO USE "FOOD & WINE", APART FROM THE MARK AS SHOWN.

THE MARK CONSISTS OF THE STYLIZED WORDING "LOS ANGELES", ALL OF WHICH APPEARS ABOVE A THIN, HORIZONTAL LINE SEGMENT, WHICH ITSELF APPEARS ABOVE THE STYLIZED WORDING "FOOD & WINE".

SEC. 2(F).

FOR ENTERTAINMENT SERVICES, NAMELY, WINE AND FOOD TASTINGS (U.S. CLS. 100, 101 AND 107).

FIRST USE 10-13-2011; IN COMMERCE 10-13-2011.

ALYSSA STEEL, EXAMINING ATTORNEY

SN 85-299,581. MAGIC MINDS BUSINESS SOLUTIONS, INC.,
QUEBEC CITY, QUEBEC, CANADA, FILED 4-20-2011.

MAGICMINDS

THE MARK CONSISTS OF STANDARD CHARACTERS WITHOUT CLAIM TO ANY PARTICULAR FONT, STYLE, SIZE, OR COLOR.

FOR EDUCATIONAL SERVICES, NAMELY, CONDUCTING CLASSES, CONFERENCES, SEMINARS AND WORKSHOPS IN THE FIELD OF GENERATING PEAK BRAIN PERFORMANCE (U.S. CLS. 100, 101 AND 107).

TINA L. SNAPP, EXAMINING ATTORNEY

SN 85-299,839. SILVA, TEA, DBA SILVA, TEA, MIAMI, FL.
FILED 4-20-2011.

Wand Fight Team Mixed Martial Arts

THE MARK CONSISTS OF STANDARD CHARACTERS WITHOUT CLAIM TO ANY PARTICULAR FONT, STYLE, SIZE, OR COLOR.

OWNER OF U.S. REG. NO. 3,629,436.

NO CLAIM IS MADE TO THE EXCLUSIVE RIGHT TO USE "FIGHT TEAM MIXED MARTIAL ARTS", APART FROM THE MARK AS SHOWN.

FOR PROVIDING CLASSES, WORKSHOPS, SEMINARS AND CAMPS IN THE FIELDS OF FITNESS, EXERCISE, BOXING, KICK BOXING AND MIXED MARTIAL ARTS (U.S. CLS. 100, 101 AND 107).

FIRST USE 2-2-2009; IN COMMERCE 2-2-2009.

MICHELE SWAIN, EXAMINING ATTORNEY

CLASS 41—(Continued).

SN 85-301,689. UNITEDHEALTH GROUP INCORPORATED,
MINNETONKA, MN. FILED 4-21-2011.

UNITEDHEALTHCARE

THE MARK CONSISTS OF STANDARD CHARACTERS WITHOUT CLAIM TO ANY PARTICULAR FONT, STYLE, SIZE, OR COLOR.

OWNER OF U.S. REG. NOS. 1,967,622, 3,269,588 AND OTHERS.

FOR EDUCATION SERVICES, NAMELY, PROVIDING ONLINE TRAINING IN THE FIELDS OF HEALTH, WELLNESS, HEALTH CARE SERVICES, HEALTH INSURANCE, HEALTH CARE BENEFIT PLANS, HEALTH CARE BENEFITS, PHARMACY BENEFITS, FLEXIBLE SPENDING ACCOUNTS, HEALTH SAVINGS ACCOUNTS AND HEALTH REIMBURSEMENT ACCOUNTS VIA A GLOBAL COMPUTER NETWORK UTILIZING COMPUTER MODULES, SOFTWARE TOOLS, VIDEO MODULES AND INTERACTIVE QUIZZES; EDUCATION SERVICES, NAMELY, PROVIDING MENTORING, TUTORING, TRAINING, CLASSES, SEMINARS AND WORKSHOPS IN THE FIELD OF NURSE PROFESSIONAL TRAINING AND ADVANCEMENT; MEDICAL TRAINING AND TEACHING; PROVIDING ON-LINE JOURNALS AND WEB LOGS FEATURING USER-CREATED CONTENT IN THE FIELDS OF HEALTH, WELLNESS, AND HEALTH RESEARCH; PROVIDING ONLINE WEBINARS FEATURING CASE STUDIES, PODCASTS, AND ONLINE PUBLICATIONS IN THE NATURE OF WHITE PAPERS IN THE FIELDS OF HEALTH AND WELLNESS AND HEALTH RESEARCH; PROVIDING TRAINING SERVICES TO OTHERS IN THE FIELDS OF EMPLOYEE ASSISTANCE AND WORK/LIFE PROGRAMS AND SERVICES; HEALTH AND WELLNESS INCENTIVE REWARD PROGRAMS DESIGNED TO REWARD PROGRAM PARTICIPANTS WHO EXERCISE, MAKE HEALTHY EATING CHOICES AND ENGAGE IN OTHER HEALTH-PROMOTING ACTIVITIES; EDUCATIONAL SERVICES, NAMELY CONDUCTING PROGRAMS IN THE FIELD OF NUTRITION, DIET, HEALTH AND WELLNESS; PROVIDING ONLINE PUBLICATIONS IN THE NATURE OF REPORTS, JOURNAL ARTICLES AND NEWSLETTERS IN THE FIELDS OF HEALTH AND WELLNESS (U.S. CLS. 100, 101 AND 107).

AMY HELLA, EXAMINING ATTORNEY

SN 85-302,278. LARKIN, RAYMOND A., SEEKONK, MA.
FILED 4-22-2011.

Budding Academy

THE MARK CONSISTS OF STANDARD CHARACTERS WITHOUT CLAIM TO ANY PARTICULAR FONT, STYLE, SIZE, OR COLOR.

NO CLAIM IS MADE TO THE EXCLUSIVE RIGHT TO USE "ACADEMY", APART FROM THE MARK AS SHOWN. FOR EDUCATIONAL SERVICES, NAMELY, CONDUCTING SEMINARS IN THE FIELD OF BOTANY, HORTICULTURE, AND THE EMERGING CANNABIS INDUSTRY (U.S. CLS. 100, 101 AND 107).

FIRST USE 2-1-2011; IN COMMERCE 2-1-2011.

ELISSA GARBER KON, EXAMINING ATTORNEY

CLASS 41—(Continued).

SN 85-302,859. HITGRAB INC., OAKVILLE, CANADA, FILED 4-23-2011.



THE COLOR(S) GREY, RED, GREEN, YELLOW, BROWN, AND BLACK IS/ARE CLAIMED AS A FEATURE OF THE MARK.

THE MARK CONSISTS OF THE WORD "FISH" IN GREY, WITH A RED OUTLINE, AND THIN YELLOW SHADING LINES ON THE RIGHT PORTION OF THE INDIVIDUAL LETTERS, ALL POSITIONED ABOVE THE WORD "HUNT" IN GREY, WITH A GREEN OUTLINE, AND THIN YELLOW SHADING LINES ON THE RIGHT PORTION OF THE INDIVIDUAL LETTERS. THE LITERAL ELEMENT IS POSITIONED BEFORE A BROWN BASE, AND THE ENTIRE MARK SITS ON A BLACK BACKGROUND, WHICH IS CLAIMED AS A FEATURE OF THE MARK.

FOR ENTERTAINMENT SERVICES, NAMELY, PROVIDING AN ON-LINE COMPUTER GAME (U.S. CLS. 100, 101 AND 107).

JORDAN BAKER, EXAMINING ATTORNEY

SN 85-303,864. KINETIC CYCLING LLC, LOS ANGELES, CA, FILED 4-25-2011.



NO CLAIM IS MADE TO THE EXCLUSIVE RIGHT TO USE "KINETIC CYCLING", APART FROM THE MARK AS SHOWN.

THE MARK CONSISTS OF WORDS, "KINETIC" AND "CYCLING" AND A SWIRLED LOOP WITH "KINETIC" IN THE MIDDLE.

FOR CONDUCTING FITNESS CLASSES, NAMELY, INDOOR CYCLING CLASSES UTILIZING INDOOR CYCLING EQUIPMENT (U.S. CLS. 100, 101 AND 107).

FIRST USE 9-1-2008; IN COMMERCE 9-1-2008.
LINDA ORNDORFF, EXAMINING ATTORNEY

CLASS 41—(Continued).

SN 85-304,224. PARENT, JOSEPH H., OJAI, CA. FILED 4-25-2011.

Zen Golf

THE MARK CONSISTS OF STANDARD CHARACTERS WITHOUT CLAIM TO ANY PARTICULAR FONT, STYLE, SIZE, OR COLOR.

OWNER OF U.S. REG. NO. 2,623,134.

NO CLAIM IS MADE TO THE EXCLUSIVE RIGHT TO USE "GOLF", APART FROM THE MARK AS SHOWN.

FOR EDUCATIONAL SERVICES, NAMELY, CONDUCTING INFORMAL ON-LINE PROGRAMS IN THE FIELDS OF GOLF, AND PRINTABLE MATERIALS DISTRIBUTED THEREWITH; EDUCATIONAL SERVICES, NAMELY, CONDUCTING ON LINE AND TELEPHONIC INSTRUCTION AND COURSES IN THE FIELD OF GOLF; EDUCATIONAL SERVICES, NAMELY, CONDUCTING PROGRAMS IN THE FIELD OF GOLF; EDUCATIONAL SERVICES, NAMELY, CONDUCTING SEMINARS, LECTURES, TELESEMINARS, TELECLASSES, AND WORKSHOPS IN PERSONAL AWARENESS; EDUCATIONAL SERVICES, NAMELY, PROFESSIONAL COACHING OF TEACHERS IN THE FIELD OF GOLF PROVIDED ON A REAL-TIME BASIS DURING CLASSROOM INSTRUCTION (U.S. CLS. 100, 101 AND 107).

FIRST USE 1-19-2002; IN COMMERCE 1-19-2002.

ZACHARY BELLO, EXAMINING ATTORNEY

SN 85-304,480. HOOD, ROGER, SOUTHFIELD, MI. FILED 4-26-2011.



NO CLAIM IS MADE TO THE EXCLUSIVE RIGHT TO USE "THE HIGHSCHOOL SPORTS NETWORK", APART FROM THE MARK AS SHOWN.

THE COLOR(S) BLACK, YELLOW, RED, BLUE, PURPLE, BROWN, TAN AND GREEN IS/ARE CLAIMED AS A FEATURE OF THE MARK.

THE MARK CONSISTS OF THE LETTERS "THSN", IN ARIAL TYPE BLACK FONT, CAPITALIZED AND STYLIZED WITH THE TOP 1/3 OF THE LETTERS SEPARATED FROM THE BOTTOM 2/3 OF THE LETTERS. TO THE LEFT ARE THREE STACKED, INTERLOCKING COLORED RINGS. THE TOP RING IS YELLOW, THE BOTTOM LEFT IS RED, AND THE BOTTOM RIGHT IS BLUE. THERE IS ONE PURPLE RING CENTERED, ABOVE THE TOP OF THE "H" AND THE "S" AND THREE INTERLOCKING, STACKED, COLORED RINGS TO THE RIGHT OF THE "N". THE TOP RING IS BROWN, THE BOTTOM LEFT IS TAN, AND THE BOTTOM RIGHT IS GREEN. THE WORDS "THE HIGH SCHOOL SPORTS NETWORK", ARE IN ARIAL TYPE BLACK FONT, ALL CAPITALIZED, BELOW THE "THSN" AND RINGS.

FOR HIGH SCHOOL SPORTS CABLE TELEVISION PROGRAMMING (U.S. CLS. 100, 101 AND 107).

MICHAEL WEBSTER, EXAMINING ATTORNEY

CLASS 41—(Continued).

SN 85-305,558. ALLYSON AMES COMPANY, INC., CORONA DEL MAR, CA. FILED 4-27-2011.

ALLYSON AMES

THE MARK CONSISTS OF STANDARD CHARACTERS WITHOUT CLAIM TO ANY PARTICULAR FONT, STYLE, SIZE, OR COLOR.

THE NAME "ALLYSON AMES" IDENTIFIES A LIVING INDIVIDUAL WHOSE CONSENT IS OF RECORD.

FOR ENTERTAINMENT SERVICES IN THE NATURE OF PRODUCTION SERVICES OF MULTIMEDIA ENTERTAINMENT CONTENT; MULTIMEDIA PUBLISHING OF BOOKS, WORKBOOKS, MAGAZINES, JOURNALS, SOFTWARE, GAMES, MUSIC, AND ELECTRONIC PUBLICATIONS (U.S. CLS. 100, 101 AND 107).

FIRST USE 1-1-2005; IN COMMERCE 1-1-2011.

JANICE L. MCMORROW, EXAMINING ATTORNEY

SN 85-306,047. INTERNATIONAL MISSION BOARD OF THE SOUTHERN BAPTIST CONVENTION, RICHMOND, VA. FILED 4-27-2011.



THE MARK CONSISTS OF THE STYLIZED LOWER CASE LETTERS "IMB" WITH THE SCRIPT WORD "CONNECTING" UNDERNEATH AND SLIGHTLY TO THE RIGHT OF THE LETTERS "IMB".

FOR EDUCATION SERVICES, NAMELY, CONDUCTING CLASSES AND SEMINARS IN THE FIELD OF RELIGIOUS EDUCATION, NAMELY, ABOUT WORLD EVANGELISM, RELIGIOUS EDUCATION AND CHRISTIAN MISSIONS; PROVIDING TRAINING IN THE FIELD OF WORLD EVANGELISM, RELIGIOUS EDUCATION AND CHRISTIAN MISSIONS; ARRANGING AND CONDUCTING TRAINING IN THE FIELD OF WORLD EVANGELISM, RELIGIOUS EDUCATION AND CHRISTIAN MISSIONS; EMPLOYMENT TRAINING IN THE FIELD OF WORLD EVANGELISM, RELIGIOUS EDUCATION AND CHRISTIAN MISSIONS; EDUCATION IN THE FIELD OF WORLD EVANGELISM, RELIGIOUS EDUCATION AND CHRISTIAN MISSIONS RENDERED THROUGH CORRESPONDENCE COURSES; PROVIDING INFORMATION AND PROVIDING INFORMATION ON-LINE IN THE FIELD OF RELIGIOUS EDUCATION, NAMELY, ABOUT WORLD EVANGELISM, RELIGIOUS EDUCATION AND CHRISTIAN MISSIONS; PROVIDING FACILITIES FOR EDUCATIONAL INSTRUCTION; PRODUCING, ORGANIZING AND PRESENTING EDUCATIONAL CONFERENCES; ORGANIZING AND CONDUCTING TRAINING IN THE FIELD OF RELIGIOUS EDUCATION, NAMELY, ABOUT WORLD EVANGELISM, RELIGIOUS EDUCATION AND CHRISTIAN MISSIONS; FESTIVALS IN THE FIELD OF RELIGIOUS EDUCATION, NAMELY, ABOUT WORLD EVANGELISM, RELIGIOUS EDUCATION AND CHRISTIAN MISSIONS; SEMINARS IN THE FIELD OF RELIGIOUS EDUCATION, NAMELY, ABOUT WORLD EVANGELISM, RELIGIOUS EDUCATION AND CHRISTIAN MISSIONS; WORKSHOPS IN THE FIELD OF RELIGIOUS EDUCATION, NAMELY, ABOUT WORLD EVANGELISM, RELIGIOUS EDUCATION AND CHRISTIAN MISSIONS; PUBLICATION OF NEWSLETTERS, MAGAZINES, AND BOOKS; TRAINING CONSULTANCY IN THE FIELD OF RELIGIOUS EDUCATION, NAMELY, ABOUT WORLD EVANGELISM, RELIGIOUS EDUCATION AND CHRISTIAN MISSIONS; PRODUCTION OF AUDIO AND VIDEO RECORDINGS, NAMELY, DVDS, VIDEOTAPES, VIDEO DISCS, AND VIDEO CASSETTES; PROVIDING INFORMATION AND PROVIDING INFORMATION BY ELECTRONIC MEANS AND VIA A GLOBAL COMPUTER NETWORK IN THE FIELD OF RELIGIOUS EDUCATION, NAMELY, ABOUT WORLD EVANGELISM, RELIGIOUS EDUCATION AND CHRISTIAN MISSIONS; PROVIDING A WEBSITE FEATURING RELIGIOUS INSTRUCTION SERVICES IN THE FIELD OF WORLD EVANGELISM, RELIGIOUS EDUCATION AND CHRISTIAN MISSIONS; PROVIDING A WEBSITE FEATURING ONLINE RELIGIOUS INSTRUCTION SERVICES FOR CHURCHES AND INDIVIDUALS REGARDING GREAT COMMISSION RELIGIOUS INSTRUCTION ACTIVITIES, WORLD EVANGELISM, RELIGIOUS EDUCATION AND CHRISTIAN MISSIONS (U.S. CLS. 100, 101 AND 107).

CLASS 41—(Continued).

FIRST USE 6-15-2009; IN COMMERCE 6-15-2009.

JULIE GUTTADAURO, EXAMINING ATTORNEY

SN 85-306,314. JUNG, KWANG HO, DAEGU, REPUBLIC OF KOREA, AND JUNG, JONG MOON, DAEGU, REPUBLIC OF KOREA, FILED 4-27-2011.

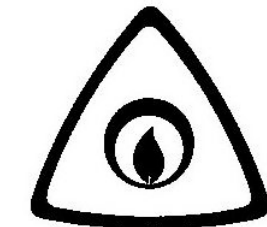

빛 Viit Meditation

NO CLAIM IS MADE TO THE EXCLUSIVE RIGHT TO USE "MEDITATION", APART FROM THE MARK AS SHOWN.

THE MARK CONSISTS OF A FLAME WITHIN A CIRCLE, BOTH ENCLOSED WITHIN AN EQUILATERAL TRIANGLE WITH BEVELED CORNERS. BELOW THE BASE OF THE TRIANGLE APPEARS A KOREAN HANGUL CHARACTER, WHICH TRANSLITERATES AS "BIT," FOLLOWED BY THE TERM "VIIT MEDITATION".

THE WORDING "VIIT" HAS NO MEANING IN A FOREIGN LANGUAGE.

THE NON-LATIN CHARACTERS IN THE MARK TRANSLITERATE TO BIT AND THIS MEANS LIGHT IN ENGLISH. FOR MEDITATION TRAINING (U.S. CLS. 100, 101 AND 107).

KATHRYN COWARD, EXAMINING ATTORNEY

CLASS 41—(Continued).

SN 85-306,726. MCCARTHY, THOMAS MATTHEW, MONROVIA, CA. FILED 4-27-2011.

SnackyShack

THE MARK CONSISTS OF STANDARD CHARACTERS WITHOUT CLAIM TO ANY PARTICULAR FONT, STYLE, SIZE, OR COLOR.

FOR ENTERTAINMENT IN THE NATURE OF VISUAL AND AUDIO PERFORMANCES, AND MUSICAL, VARIETY, NEWS AND COMEDY SHOWS; ENTERTAINMENT SERVICES, NAMELY, PROVIDING ON-GOING WEBSITES FEATURING MUSIC ARTISTS, COMEDIANS, ACTORS, PERFORMING ARTISTS, AND VISUAL ARTISTS VIA A GLOBAL COMPUTER NETWORK (U.S. CLS. 100, 101 AND 107).

FIRST USE 4-19-2011; IN COMMERCE 4-19-2011.
MICHAEL SOUDERS, EXAMINING ATTORNEY

CLASS 41—(Continued).

SN 85-306,922. BAKER & TAYLOR, INC., CHARLOTTE, NC. FILED 4-28-2011.



NO CLAIM IS MADE TO THE EXCLUSIVE RIGHT TO USE "DIGITAL MEDIA LIBRARY", APART FROM THE MARK AS SHOWN.

THE COLOR(S) GREEN AND GRAY IS/ARE CLAIMED AS A FEATURE OF THE MARK.

THE MARK CONSISTS OF THE STYLIZED WORDS "AXIS 360 DIGITAL MEDIA LIBRARY BY BAKER & TAYLOR" TOGETHER WITH THE DESIGN OF A PARTIAL SUNBURST AROUND THE "0" IN "360", WITH THE WORD "AXIS" IN GREEN AND THE REST OF THE MARK IN GRAY.

FOR ON-LINE LIBRARY SERVICES, NAMELY, PROVIDING ELECTRONIC LIBRARY CIRCULATION SERVICES WHICH FEATURE E-BOOKS (U.S. CLS. 100, 101 AND 107).

SUSAN STIGLITZ, EXAMINING ATTORNEY

SN 85-306,920. BAKER & TAYLOR, INC., CHARLOTTE, NC. FILED 4-28-2011.



NO CLAIM IS MADE TO THE EXCLUSIVE RIGHT TO USE "DIGITAL MEDIA LIBRARY", APART FROM THE MARK AS SHOWN.

THE MARK CONSISTS OF THE STYLIZED WORDS "AXIS 360 DIGITAL MEDIA LIBRARY BY BAKER & TAYLOR" TOGETHER WITH THE DESIGN OF A PARTIAL SUNBURST AROUND THE "0" IN "360".

FOR ON-LINE LIBRARY SERVICES, NAMELY, PROVIDING ELECTRONIC LIBRARY CIRCULATION SERVICES WHICH FEATURE E-BOOKS (U.S. CLS. 100, 101 AND 107).

SUSAN STIGLITZ, EXAMINING ATTORNEY

GCOM

THE MARK CONSISTS OF STANDARD CHARACTERS WITHOUT CLAIM TO ANY PARTICULAR FONT, STYLE, SIZE, OR COLOR.

FOR EDUCATIONAL SERVICES, NAMELY, PROVIDING COURSES OF INSTRUCTION AT THE UNDERGRADUATE, GRADUATE AND PROFESSIONAL LEVELS IN THE FIELDS OF HEALTH CARE AND MEDICINE; RESEARCH IN THE FIELD OF MEDICAL EDUCATION; CONDUCTING EDUCATIONAL SEMINARS, LECTURES AND CONFERENCES IN THE FIELDS OF HEALTH CARE AND MEDICINE; ENTERTAINMENT SERVICES, NAMELY, CONDUCTING ATHLETIC AND CULTURAL EVENTS OCCURRING AT A COLLEGE OF MEDICINE (U.S. CLS. 100, 101 AND 107).

MICHAEL ENGEL, EXAMINING ATTORNEY

SN 85-309,899. PHILADELPHIA COLLEGE OF OSTEO-PATHIC MEDICINE, PHILADELPHIA, PA. FILED 5-2-2011.

CLASS 41—(Continued).

SN 85-310,078. PHILADELPHIA COLLEGE OF OSTEO-PATHIC MEDICINE, PHILADELPHIA, PA. FILED 5-2-2011.

GSP

THE MARK CONSISTS OF STANDARD CHARACTERS WITHOUT CLAIM TO ANY PARTICULAR FONT, STYLE, SIZE, OR COLOR.

FOR EDUCATIONAL SERVICES, NAMELY PROVIDING COURSES OF INSTRUCTION AT THE UNDERGRADUATE, GRADUATE AND PROFESSIONAL LEVELS IN THE FIELDS OF HEALTH CARE AND MEDICINE; RESEARCH IN THE FIELD OF MEDICAL EDUCATION; CONDUCTING EDUCATIONAL SEMINARS, LECTURES AND CONFERENCES IN THE FIELDS OF HEALTH CARE AND MEDICINE; ENTERTAINMENT SERVICES, NAMELY, CONDUCTING ATHLETIC AND CULTURAL EVENTS OCCURRING AT A COLLEGE OF MEDICINE (U.S. CLS. 100, 101 AND 107).
MICHAEL ENGEL, EXAMINING ATTORNEY

SN 85-310,081. PHILADELPHIA COLLEGE OF OSTEO-PATHIC MEDICINE, PHILADELPHIA, PA. FILED 5-2-2011.

GCP

THE MARK CONSISTS OF STANDARD CHARACTERS WITHOUT CLAIM TO ANY PARTICULAR FONT, STYLE, SIZE, OR COLOR.

FOR EDUCATIONAL SERVICES, NAMELY, PROVIDING COURSES OF INSTRUCTION AT THE UNDERGRADUATE, GRADUATE AND PROFESSIONAL LEVELS IN THE FIELDS OF HEALTH CARE AND MEDICINE; RESEARCH IN THE FIELD OF MEDICAL EDUCATION; CONDUCTING EDUCATIONAL SEMINARS, LECTURES AND CONFERENCES IN THE FIELDS OF HEALTH CARE AND MEDICINE; ENTERTAINMENT SERVICES, NAMELY, CONDUCTING ATHLETIC AND CULTURAL EVENTS OCCURRING AT A COLLEGE OF MEDICINE (U.S. CLS. 100, 101 AND 107).
MICHAEL ENGEL, EXAMINING ATTORNEY

CLASS 41—(Continued).

SN 85-320,814. CITY OF HOPE, DUARTE, CA. FILED 5-13-2011.

YOGA FOR HOPE

THE MARK CONSISTS OF STANDARD CHARACTERS WITHOUT CLAIM TO ANY PARTICULAR FONT, STYLE, SIZE, OR COLOR.

NO CLAIM IS MADE TO THE EXCLUSIVE RIGHT TO USE "YOGA", APART FROM THE MARK AS SHOWN.

FOR ENTERTAINMENT AND RECREATIONAL SERVICES, NAMELY, PROVIDING PHYSICAL FITNESS AND YOGA INSTRUCTION (U.S. CLS. 100, 101 AND 107).

FIRST USE 6-8-2002; IN COMMERCE 6-8-2002.
NATALIE POLZER, EXAMINING ATTORNEY

SN 85-324,407. REVELLE INDEPENDENT LLC, LOS ANGELES, CA. FILED 5-18-2011.

**WHO KNEW? Just
when you thought you
knew the news . . .**

THE MARK CONSISTS OF STANDARD CHARACTERS WITHOUT CLAIM TO ANY PARTICULAR FONT, STYLE, SIZE, OR COLOR.

FOR ENTERTAINMENT SERVICES, NAMELY, THE PROVISION OF CONTINUING SHOWS FEATURING NEWS DELIVERED BY TELEVISION AND THE INTERNET; ENTERTAINMENT, NAMELY, A CONTINUING NEWS SHOW BROADCAST OVER TELEVISION, SATELLITE, AUDIO, AND VIDEO MEDIA (U.S. CLS. 100, 101 AND 107).

THOMAS MANOR, EXAMINING ATTORNEY

SN 85-324,410. REVELLE INDEPENDENT LLC, LOS ANGELES, CA. FILED 5-18-2011.

WHO KNEW?

THE MARK CONSISTS OF STANDARD CHARACTERS WITHOUT CLAIM TO ANY PARTICULAR FONT, STYLE, SIZE, OR COLOR.

FOR ENTERTAINMENT SERVICES, NAMELY, THE PROVISION OF CONTINUING SHOWS FEATURING NEWS DELIVERED BY TELEVISION AND THE INTERNET; ENTERTAINMENT, NAMELY, A CONTINUING NEWS SHOW BROADCAST OVER TELEVISION, SATELLITE, AUDIO, AND VIDEO MEDIA (U.S. CLS. 100, 101 AND 107).

THOMAS MANOR, EXAMINING ATTORNEY

CLASS 41—(Continued).

SN 85-326,501. GREY GLOBAL GROUP INC., NEW YORK, NY. FILED 5-20-2011.

GRAVY TALKS

THE MARK CONSISTS OF STANDARD CHARACTERS WITHOUT CLAIM TO ANY PARTICULAR FONT, STYLE, SIZE, OR COLOR.

NO CLAIM IS MADE TO THE EXCLUSIVE RIGHT TO USE "TALKS", APART FROM THE MARK AS SHOWN.

FOR ENTERTAINMENT AND EDUCATIONAL SERVICES, NAMELY, THE PRESENTATION OF LECTURES AND PANEL DISCUSSIONS IN THE FIELDS OF ADVERTISING AND CREATIVE ENDEAVORS FOR THE CREATIVE, ADVERTISING, AND MARKETING COMMUNITIES (U.S. CLS. 100, 101 AND 107).

FIRST USE 12-0-2010; IN COMMERCE 12-0-2010.
ERIN FALK, EXAMINING ATTORNEY

SN 85-328,123. FLYWHEEL SPORTS, INC., NEW YORK, NY. FILED 5-23-2011.

GUYBARRE

THE MARK CONSISTS OF STANDARD CHARACTERS WITHOUT CLAIM TO ANY PARTICULAR FONT, STYLE, SIZE, OR COLOR.

THE NAME(S), PORTRAIT(S), AND/OR SIGNATURE(S) SHOWN IN THE MARK DOES NOT IDENTIFY A PARTICULAR LIVING INDIVIDUAL.

FOR PROVIDING FITNESS AND EXERCISE STUDIO SERVICES, NAMELY, INDOOR CYCLING INSTRUCTION, PERSONAL TRAINING AND PHYSICAL FITNESS CLASSES; COUNSELING SERVICES IN THE FIELD OF EXERCISE (U.S. CLS. 100, 101 AND 107).

TINA L. SNAPP, EXAMINING ATTORNEY

SN 85-328,497. EPIC ANGLING & ADVENTURE, LLC, AUSTIN, TX. FILED 5-24-2011.

EPIC ANGLING & ADVENTURE

THE MARK CONSISTS OF STANDARD CHARACTERS WITHOUT CLAIM TO ANY PARTICULAR FONT, STYLE, SIZE, OR COLOR.

NO CLAIM IS MADE TO THE EXCLUSIVE RIGHT TO USE "ANGLING", APART FROM THE MARK AS SHOWN.

FOR FISHING GUIDE SERVICES; OUTDOOR RECREATION GUIDE SERVICES, NAMELY, PROVIDING GUIDES AND ARRANGING TRIPS INVOLVING HIKING, CAMPING, RIVER RAFTING, WILDLIFE VIEWING AND OTHER OUTDOOR ACTIVITIES (U.S. CLS. 100, 101 AND 107).

FIRST USE 1-28-2004; IN COMMERCE 7-6-2004.
REGINA DRUMMOND, EXAMINING ATTORNEY

CLASS 41—(Continued).

SN 85-329,930. ATLANTIC MEDIA COMPANY, WASHINGTON, DC. FILED 5-25-2011.

NATIONAL JOURNAL DAILY

THE MARK CONSISTS OF STANDARD CHARACTERS WITHOUT CLAIM TO ANY PARTICULAR FONT, STYLE, SIZE, OR COLOR.

OWNER OF U.S. REG. NO. 917,681.

NO CLAIM IS MADE TO THE EXCLUSIVE RIGHT TO USE "JOURNAL DAILY", APART FROM THE MARK AS SHOWN.

SEC. 2(F).

FOR PROVIDING ON-LINE NEWSLETTERS IN THE FIELD OF POLITICS AND POLITICAL NEWS (U.S. CLS. 100, 101 AND 107).

FIRST USE 10-26-2010; IN COMMERCE 10-26-2010.

MICHAEL ENGEL, EXAMINING ATTORNEY

SN 85-336,427. DANIEL D'ARCO, POTTSVILLE, PA. FILED 6-2-2011.

THE ORIGIN OF MAGIC

THE MARK CONSISTS OF STANDARD CHARACTERS WITHOUT CLAIM TO ANY PARTICULAR FONT, STYLE, SIZE, OR COLOR.

FOR ENTERTAINMENT SERVICES, NAMELY, PRODUCTION AND DISTRIBUTION OF MOTION PICTURES; SCRIPT DEVELOPMENT, NAMELY, SCRIPTWRITING SERVICES; ENTERTAINMENT INFORMATION, NAMELY, PROVIDING ONLINE NEWS AND INFORMATION RELATED TO MOTION PICTURES, SCIENCE FICTION TOPICS AND COMPUTER GAMING; CONSULTING IN THE FIELD OF MOTION PICTURE PRODUCTION (U.S. CLS. 100, 101 AND 107).

SANI KHOURI, EXAMINING ATTORNEY

CLASS 41—(Continued).

SN 85-341,016. CHRISTIANS FOR ISRAEL INTERNATIONAL, NIJKERK, NETHERLANDS, FILED 6-8-2011.

CHRISTIANS FOR ISRAEL

THE MARK CONSISTS OF STANDARD CHARACTERS WITHOUT CLAIM TO ANY PARTICULAR FONT, STYLE, SIZE, OR COLOR.

SEC. 2(F).

FOR GUIDED TOURS OF HISTORICAL AND RELIGIOUS SITES IN ISRAEL; EDUCATIONAL SERVICES, NAMELY, PROVIDING CONFERENCES, SEMINARS, WORKSHOPS, AND LECTURES IN THE FIELDS OF INTER-RELIGIOUS DIALOGUE, CHRISTIANITY, JUDAISM, BIBLICAL PROPHECY AND HISTORY, AND A BIBLICAL UNDERSTANDING OF THE JEWISH PEOPLE, AND DISTRIBUTION OF EDUCATIONAL MATERIAL IN CONNECTION THEREWITH (U.S. CLS. 100, 101 AND 107).

FIRST USE 0-0-1998; IN COMMERCE 0-0-1998.

ADA HAN, EXAMINING ATTORNEY

SN 85-345,203. CAPRIO, BRENDA, SCOTTSDALE, AZ. FILED 6-14-2011.

AWESOME MANNERED K9S

THE MARK CONSISTS OF STANDARD CHARACTERS WITHOUT CLAIM TO ANY PARTICULAR FONT, STYLE, SIZE, OR COLOR.

NO CLAIM IS MADE TO THE EXCLUSIVE RIGHT TO USE "K9S", APART FROM THE MARK AS SHOWN.

FOR DOG TRAINING SERVICES (U.S. CLS. 100, 101 AND 107).

BRIAN NEVILLE, EXAMINING ATTORNEY

SN 85-345,952. SOURCE INTERLINK MAGAZINES, LLC, EL SEGUNDO, CA. FILED 6-14-2011.

MUD LIFE

THE MARK CONSISTS OF STANDARD CHARACTERS WITHOUT CLAIM TO ANY PARTICULAR FONT, STYLE, SIZE, OR COLOR.

OWNER OF U.S. REG. NO. 3,748,352.

NO CLAIM IS MADE TO THE EXCLUSIVE RIGHT TO USE "MUD", APART FROM THE MARK AS SHOWN.

FOR ENTERTAINMENT SERVICES IN THE NATURE ORGANIZING, OPERATING, AND CONDUCTING MUD TRUCK COMPETITIONS, EXHIBITIONS, AND EVENTS FEATURING MUD TRUCKS, ALL-TERRAIN VEHICLES, AND OTHER OFF-ROAD VEHICLES (U.S. CLS. 100, 101 AND 107).

FIRST USE 1-15-2009; IN COMMERCE 1-15-2009.

ALICE BENMAMAN, EXAMINING ATTORNEY

CLASS 41—(Continued).

SN 85-347,506. ENTERTAINMENT CONTENT, INC., LOS ANGELES, CA. FILED 6-16-2011.

LEGADO.TV

THE MARK CONSISTS OF STANDARD CHARACTERS WITHOUT CLAIM TO ANY PARTICULAR FONT, STYLE, SIZE, OR COLOR.

THE ENGLISH TRANSLATION OF "LEGADO" IN THE MARK IS "LEGACY".

FOR PROVIDING ENTERTAINMENT, EDUCATIONAL AND INFORMATIONAL ONGOING PROGRAMS IN THE FIELDS OF BUSINESS, ENTERTAINMENT, MEDICINE, HEALTHCARE, PSYCHOLOGY, LEGAL, SPORTS, ACCOMPLISHED ARTISTS, SCHOLARS, PHILANTHROPISTS, AND ENTREPRENEURS ACCESSIBLE BY SATELLITE, TELEVISION, INTERNET, WIRELESS NETWORKS AND THROUGH TRANSMISSION OF AUDIO AND/OR VIDEO SIGNALS TO ANY TYPE OF VISUAL DISPLAY DEVICE; PRODUCTION AND DISTRIBUTION OF TELEVISION SHOWS (U.S. CLS. 100, 101 AND 107).

NATALIE POLZER, EXAMINING ATTORNEY

SN 85-351,162. PROQUEST LLC, ANN ARBOR, MI. FILED 6-20-2011.



OWNER OF U.S. REG. NOS. 1,656,697, 2,468,946 AND 2,751,655.

THE MARK CONSISTS OF THE WORD "PROQUEST" CONTAINING A CAPITAL "P" AND A STYLIZED CAPITAL "Q" THAT HAS AN ELONGATED WAVY TAIL. THE REMAINING LETTERS ARE IN LOWER CASE, AND THERE IS A THIN UNDERLINING ARC BENEATH THE "PRO" AND "UEST" PORTIONS OF THE MARK.

FOR ONLINE SERVICES, NAMELY, PROVIDING EDUCATIONAL, INSTRUCTIONAL, TEACHING, AND GENERAL REFERENCE EDUCATIONAL MATERIALS, IN A WIDE VARIETY OF FIELDS (U.S. CLS. 100, 101 AND 107).

VIVIAN MICZNIK FIRST, EXAMINING ATTORNEY

CLASS 41—(Continued).

SN 85-353,146. KIMAMA EDUCATION PROGRAMS, LTD., KIBBUTZ SHFAIM, ISRAEL, FILED 6-22-2011.

KIMAMA CAMP USA

THE MARK CONSISTS OF STANDARD CHARACTERS WITHOUT CLAIM TO ANY PARTICULAR FONT, STYLE, SIZE, OR COLOR.

NO CLAIM IS MADE TO THE EXCLUSIVE RIGHT TO USE "CAMP USA", APART FROM THE MARK AS SHOWN.

THE ENGLISH TRANSLATION OF "KIMAMA" IN THE MARK IS "BUTTERFLY".

FOR SUMMER CAMPS; CONDUCTING WORKSHOPS AND SEMINARS IN THE FIELD OF TEAM BUILDING AND LEADERSHIP DEVELOPMENT (U.S. CLS. 100, 101 AND 107).

KELLY CHOE, EXAMINING ATTORNEY

SN 85-353,162. KIMAMA EDUCATION PROGRAMS, LTD., KIBBUTZ, SHFAIM, ISRAEL, FILED 6-22-2011.



OWNER OF ISRAEL REG. NO. 217595, DATED 3-18-2010, EXPIRES 12-28-2018.

NO CLAIM IS MADE TO THE EXCLUSIVE RIGHT TO USE "CAMP" "ISRAEL" AND "FAMILY", APART FROM THE MARK AS SHOWN.

THE COLOR(S) BLACK, BLUE, ORANGE AND YELLOW IS/ARE CLAIMED AS A FEATURE OF THE MARK.

THE MARK CONSISTS OF BUTTERFLY DESIGN WITH ARMS, LEGS AND HEAD IN THE COLORS BLACK, BLUE, ORANGE AND YELLOW, AND BELOW APPEARS BLUE VERTICAL LINES WITH THE WORDING "KIMAMA CAMP ISRAEL" IN BLACK, AND BENEATH ARE THE WORDS "SPIRIT" "ADVENTURE" AND "FAMILY" IN BLACK SEPARATED BY TWO ORANGE CIRCLES; THE COLOR WHITE IS NOT CLAIMED AS PART OF THE MARK BUT REPRESENTS TRANSPARENT BACKGROUND.

THE ENGLISH TRANSLATION OF "KIMAMA" IN THE MARK IS "BUTTERFLY".

FOR SUMMER CAMPS; CONDUCTING WORKSHOPS AND SEMINARS IN THE FIELD OF TEAM BUILDING AND LEADERSHIP DEVELOPMENT (U.S. CLS. 100, 101 AND 107).

KELLY CHOE, EXAMINING ATTORNEY

CLASS 41—(Continued).

SN 85-353,177. KIMAMA EDUCATION PROGRAMS, LTD., KIBBUTZ, SHFAIM, ISRAEL, FILED 6-22-2011.



NO CLAIM IS MADE TO THE EXCLUSIVE RIGHT TO USE "CAMP USA" AND "FAMILY", APART FROM THE MARK AS SHOWN.

THE COLOR(S) BLACK, BLUE, ORANGE AND YELLOW IS/ARE CLAIMED AS A FEATURE OF THE MARK.

THE MARK CONSIST OF BUTTERFLY DESIGN WITH ARMS, LEGS AND HEAD IN THE COLOR BLACK, BLUE, ORANGE AND YELLOW, AND BELOW APPEARS BLUE VERTICAL LINES WITH THE WORDING "KIMAMA CAMP USA" IN BLACK, AND BENEATH ARE THE WORDS "SPIRIT" "ADVENTURE" AND "FAMILY" IN BLACK SEPARATED BY TWO ORANGE CIRCLES; THE COLOR WHITE IS NOT CLAIMED AS PART OF THE MARK BUT REPRESENTS TRANSPARENT BACKGROUND.

THE ENGLISH TRANSLATION OF "KIMAMA" IN THE MARK IS "BUTTERFLY".

FOR SUMMER CAMPS; CONDUCTING WORKSHOPS AND SEMINARS IN THE FIELD OF TEAM BUILDING AND LEADERSHIP DEVELOPMENT (U.S. CLS. 100, 101 AND 107).

KELLY CHOE, EXAMINING ATTORNEY

SN 85-355,555. THE TAILHOOK ASSOCIATION, SAN DIEGO, CA. FILED 6-24-2011.



NO CLAIM IS MADE TO THE EXCLUSIVE RIGHT TO USE "ASSOCIATION" AND "CARRIER NAVY", APART FROM THE MARK AS SHOWN.

THE STIPPLING IS FOR SHADING PURPOSES ONLY.

THE MARK CONSISTS OF A CIRCULAR BORDER. WITHIN, AND ADJACENT TO, THE BORDER IS A CONTINUOUS ARRESTING CABLE THAT DEPARTS FROM THE BORDER IN THE LOWER LEFT QUADRANT, AND THE WORDS "CARRIER NAVY" APPEAR IN THE WHITE

CLASS 41—(Continued).

SPACE BETWEEN THE BORDER AND THE ARRESTING CABLE. THE SPACE ON THE INSIDE OF THE ARRESTING CABLE, CONTAINS THE WORDS "TAILHOOK ASSOCIATION" AT THE TOP WITH THE NAVAL AVIATOR DESIGNATOR DEVICE CONSISTING OF AN EAGLE SPREAD WINGS APPEARING DIRECTLY BELOW THOSE WORDS, A BLACK AND WHITE STRIPPED HOOK EXTENDING DIAGONALLY FROM THE LOWER LEFT QUADRANT, AND AN AIRCRAFT CARRIER AND OCEAN AT THE BOTTOM.

FOR EDUCATIONAL SERVICES, NAMELY, CONDUCTING CONFERENCES IN THE FIELD OF CARRIER AVIATION'S ROLE IN THE PAST, PRESENT AND FUTURE OF THE NATION'S DEFENSE AND DISTRIBUTION OF EDUCATIONAL MATERIALS IN CONNECTION THEREWITH (U.S. CLS. 100, 101 AND 107).

FIRST USE 9-1-1956; IN COMMERCE 9-1-1956.
ZACHARY BELLO, EXAMINING ATTORNEY

SN 85-356,690. RILEY, JAMES R., NORTHPORT, AL. FILED 6-27-2011.

The Grain Game

THE MARK CONSISTS OF STANDARD CHARACTERS WITHOUT CLAIM TO ANY PARTICULAR FONT, STYLE, SIZE, OR COLOR.

FOR CHARITABLE SERVICES, NAMELY, PROVIDING CAMPS FOR KIDS AND TEENAGERS; EDUCATIONAL SERVICES, NAMELY, CONDUCTING CLASSES, SEMINARS, CONFERENCES, WORKSHOPS, RETREATS, CAMPS AND FIELD TRIPS IN THE FIELD OF BIBLE TEACHING AND DISTRIBUTION OF TRAINING MATERIAL IN CONNECTION THEREWITH (U.S. CLS. 100, 101 AND 107).

FIRST USE 12-1-2004; IN COMMERCE 5-1-2007.
BRIDGETT SMITH, EXAMINING ATTORNEY

SN 85-360,564. A. ALLEN ROWE, SOUTHLAKE, TX. FILED 6-30-2011.

The Whole Me Diet

THE MARK CONSISTS OF STANDARD CHARACTERS WITHOUT CLAIM TO ANY PARTICULAR FONT, STYLE, SIZE, OR COLOR.

NO CLAIM IS MADE TO THE EXCLUSIVE RIGHT TO USE "DIET", APART FROM THE MARK AS SHOWN.

FOR EDUCATION SERVICES, NAMELY, PROVIDING ON-LINE CLASSES, TRAINING, COACHING AND WORKSHOPS ACCESSIBLE VIA VIDEO MEDIA AND EMAIL IN THE FIELD OF DIET, WEIGHT LOSS, DIET PLANNING, FITNESS, AND COMPREHENSIVE LIFESTYLE HEALTH AND WELLNESS; PROVIDING A WEBSITE FEATURING BLOGS IN THE FIELDS OF DIET, WEIGHT LOSS, DIET PLANNING AND COMPREHENSIVE HEALTH AND LIFESTYLE WELLNESS (U.S. CLS. 100, 101 AND 107).

FIRST USE 2-23-2011; IN COMMERCE 2-23-2011.
NAAKWAMA ANKRAH, EXAMINING ATTORNEY

CLASS 41—(Continued).

SN 85-361,046. COMISSO, GRACE, RANCHO CUCAMONGA, CA. FILED 6-30-2011.

The Pen and Brush Overlap

THE MARK CONSISTS OF STANDARD CHARACTERS WITHOUT CLAIM TO ANY PARTICULAR FONT, STYLE, SIZE, OR COLOR.

FOR EDUCATIONAL SERVICES, NAMELY, CONDUCTING COURSES OF INSTRUCTION IN THE FIELD OF PAINTING (U.S. CLS. 100, 101 AND 107).

REBECCA SMITH, EXAMINING ATTORNEY

SN 85-368,221. TOUCHDOWN TOTS FRANCHISING LLC, DBA TOUCHDOWN TOTS, FRISCO, TX. FILED 7-11-2011.



NO CLAIM IS MADE TO THE EXCLUSIVE RIGHT TO USE "TOTS", APART FROM THE MARK AS SHOWN.

THE COLOR(S) RED, BLACK AND WHITE IS/ARE CLAIMED AS A FEATURE OF THE MARK.

THE MARK CONSISTS OF A WHITE AND BLACK FOOTBALL PLAYER KICKING A WHITE AND BLACK FOOTBALL THROUGH A BLACK GOALPOST FOLLOWED BY A TRAIL OF BLACK BROKEN LINES. THE PLAYER IS WEARING A BLACK HELMET, RED JERSEY, BLACK PANTS, WHITE SOCKS AND WHITE SHOES. THE WORDING "TOUCHDOWN TOTS" IS WRITTEN OUT IN RED TO THE RIGHT OF THE PLAYER, WITH THE LETTERS "H" AND "D" IN THE WORD "TOUCHDOWN" AND THE FIRST LETTER "T" IN THE WORD "TOTS" PART OF THE GOALPOST.

FOR ARRANGING AND CONDUCTING YOUTH FOOTBALL PROGRAMS (U.S. CLS. 100, 101 AND 107).

FIRST USE 6-1-2011; IN COMMERCE 6-1-2011.
TINA MAI, EXAMINING ATTORNEY

CLASS 41—(Continued).

SN 85-371,651. PHILADELPHIA UNIVERSITY, PHILADELPHIA, PA. FILED 7-14-2011.



OWNER OF U.S. REG. NOS. 2,709,727 AND 3,569,999.
THE MARK CONSISTS OF A STYLIZED LETTER "P".

FOR EDUCATIONAL SERVICES, NAMELY, PROVIDING INSTRUCTION AND TRAINING AT THE UNDERGRADUATE AND GRADUATE LEVELS AND CONTINUING AND PROFESSIONAL EDUCATION CLASSES IN THE FIELDS OF ARCHITECTURE, BUSINESS, DESIGN, ENGINEERING, FASHION, HEALTH, SCIENCE AND TEXTILES; PROVIDING EDUCATIONAL RESEARCH PROGRAMS FOR THE STUDY OF ARCHITECTURE, BUSINESS, DESIGN, ENGINEERING, FASHION, HEALTH, SCIENCE AND TEXTILES; PROVIDING CONTINUING AND PROFESSIONAL EDUCATION CONFERENCES, SEMINARS AND WORKSHOPS IN THE FIELDS OF ARCHITECTURE, BUSINESS, DESIGN, ENGINEERING, FASHION, HEALTH, SCIENCE AND TEXTILES; CONDUCTING CONFERENCES, SEMINARS AND WORKSHOPS RELATING TO THE STUDY OF ARCHITECTURE, BUSINESS, DESIGN, ENGINEERING, FASHION, HEALTH, SCIENCE AND TEXTILES; PUBLICATION OF NEWSLETTERS, MONOGRAPHS, NEWSPAPERS, BOOKS, COMMEMORATIVE PROGRAMS AND OTHER ELECTRONIC AND PRINTED PUBLICATIONS RELATING TO THE EDUCATIONAL SERVICES PROVIDED, NONE OF THE AFOREMENTIONED SERVICES BEING FOR ADVERTISING MATERIALS; AND ENTERTAINMENT SERVICES IN THE NATURE OF THE PRESENTATION OF A VARIETY OF INTERCOLLEGIATE SPORTING EVENTS, NAMELY, BASEBALL, BASKETBALL, GOLF, LACROSSE, SOFTBALL, CROSS-COUNTRY RUNNING, ROWING, TENNIS AND VOLLEYBALL EVENTS (U.S. CLS. 100, 101 AND 107).

FIRST USE 6-10-2011; IN COMMERCE 7-11-2011.

TINA L. SNAPP, EXAMINING ATTORNEY

CLASS 41—(Continued).

SN 85-371,671. PHILADELPHIA UNIVERSITY, PHILADELPHIA, PA. FILED 7-14-2011.

POWERED TO DO

THE MARK CONSISTS OF STANDARD CHARACTERS WITHOUT CLAIM TO ANY PARTICULAR FONT, STYLE, SIZE, OR COLOR.

OWNER OF U.S. REG. NO. 3,563,820.

FOR EDUCATIONAL SERVICES, NAMELY, PROVIDING INSTRUCTION AND TRAINING AT THE UNDERGRADUATE AND GRADUATE LEVELS AND CONTINUING AND PROFESSIONAL EDUCATION CLASSES IN THE FIELDS OF ARCHITECTURE, BUSINESS, DESIGN, ENGINEERING, FASHION, HEALTH, SCIENCE AND TEXTILES; PROVIDING EDUCATIONAL RESEARCH PROGRAMS FOR THE STUDY OF ARCHITECTURE, BUSINESS, DESIGN, ENGINEERING, FASHION, HEALTH, SCIENCE AND TEXTILES; PROVIDING CONTINUING AND PROFESSIONAL EDUCATION CONFERENCES, SEMINARS AND WORKSHOPS IN THE FIELDS OF ARCHITECTURE, BUSINESS, DESIGN, ENGINEERING, FASHION, HEALTH, SCIENCE AND TEXTILES; CONDUCTING CONFERENCES, SEMINARS AND WORKSHOPS RELATING TO THE STUDY OF ARCHITECTURE, BUSINESS, DESIGN, ENGINEERING, FASHION, HEALTH, SCIENCE AND TEXTILES; PUBLICATION OF NEWSLETTERS, MONOGRAPHS, NEWSPAPERS, BOOKS, COMMEMORATIVE PROGRAMS AND OTHER ELECTRONIC AND PRINTED PUBLICATIONS RELATING TO THE EDUCATIONAL SERVICES PROVIDED, NONE OF THE AFOREMENTIONED SERVICES BEING FOR ADVERTISING MATERIALS; AND ENTERTAINMENT SERVICES IN THE NATURE OF THE PRESENTATION OF A VARIETY OF INTERCOLLEGIATE SPORTING EVENTS, NAMELY, BASEBALL, BASKETBALL, GOLF, LACROSSE, SOFTBALL, CROSS-COUNTRY RUNNING, ROWING, TENNIS AND VOLLEYBALL EVENTS (U.S. CLS. 100, 101 AND 107).

FIRST USE 6-10-2011; IN COMMERCE 7-11-2011.

TINA L. SNAPP, EXAMINING ATTORNEY

SN 85-371,752. DISCOVERY COMMUNICATIONS, LLC, SILVER SPRING, MD. FILED 7-14-2011.

DINOSAUR REVOLUTION

THE MARK CONSISTS OF STANDARD CHARACTERS WITHOUT CLAIM TO ANY PARTICULAR FONT, STYLE, SIZE, OR COLOR.

NO CLAIM IS MADE TO THE EXCLUSIVE RIGHT TO USE "DINOSAUR", APART FROM THE MARK AS SHOWN.

FOR ENTERTAINMENT AND EDUCATIONAL SERVICES IN THE NATURE OF TELEVISION AND MULTIMEDIA PROGRAM SERIES FEATURING SUBJECTS OF GENERAL HUMAN INTEREST DISTRIBUTED VIA VARIOUS PLATFORMS ACROSS MULTIPLE FORMS OF TRANSMISSION MEDIA; PROVIDING ENTERTAINMENT INFORMATION TO OTHERS VIA A GLOBAL COMPUTER NETWORK (U.S. CLS. 100, 101 AND 107).

BRIAN PINO, EXAMINING ATTORNEY

CLASS 41—(Continued).

SN 85-372,216. TACONIC PARTNERS, LLC, ST. PAUL, MN.
FILED 7-15-2011.

WAYVIEW

THE MARK CONSISTS OF STANDARD CHARACTERS WITHOUT CLAIM TO ANY PARTICULAR FONT, STYLE, SIZE, OR COLOR.

FOR EDUCATIONAL SERVICES, NAMELY, CONDUCTING WORKSHOPS IN THE FIELD OF SMALL GROUP CONSENSUS AND STRATEGIC PLANNING FOR NON-PROFIT AND COMMERCIAL ORGANIZATIONS (U.S. CLS. 100, 101 AND 107).

TASHIA BUNCH, EXAMINING ATTORNEY

SN 85-373,113. SIMMONS, MARIA C., DBA IMPROV-ED.,
HANSON, MA. FILED 7-16-2011.

**IMPROV-ED. PEACE BY PIECE:
UNITY ONE SCENE AT A TIME**

THE MARK CONSISTS OF STANDARD CHARACTERS WITHOUT CLAIM TO ANY PARTICULAR FONT, STYLE, SIZE, OR COLOR.

FOR EDUCATION SERVICES, NAMELY, PROVIDING CLASSES AND WORKSHOPS IN THE FIELD OF DRAMATIC IMPROVISATION (U.S. CLS. 100, 101 AND 107).

FIRST USE 1-25-2011; IN COMMERCE 1-25-2011.

TIMOTHY FINNEGAN, EXAMINING ATTORNEY

SN 85-376,874. YABLON, ERIC, NORTH RICHLAND HILLS,
TX. FILED 7-21-2011.

LOVE YOUR BOOBIES

THE MARK CONSISTS OF STANDARD CHARACTERS WITHOUT CLAIM TO ANY PARTICULAR FONT, STYLE, SIZE, OR COLOR.

FOR EDUCATIONAL SERVICES, NAMELY, PROVIDING ON-LINE NON-DOWNLOADABLE BROCHURES, ARTICLES AND HANDOUTS IN THE FIELD OF BREAST CANCER (U.S. CLS. 100, 101 AND 107).

FIRST USE 6-14-2010; IN COMMERCE 6-14-2010.

JULIE GUTTADAURO, EXAMINING ATTORNEY

CLASS 41—(Continued).

SN 85-377,211. STATE OF OREGON ACTING BY AND THROUGH THE STATE BOARD OF HIGHER EDUCATION ON BEHALF OF OREGON STATE UNIVERSITY, CORVALLIS, OR. FILED 7-21-2011.

BETTER BONES & BALANCE

THE MARK CONSISTS OF STANDARD CHARACTERS WITHOUT CLAIM TO ANY PARTICULAR FONT, STYLE, SIZE, OR COLOR.

SEC. 2(F).

FOR PROVIDING INFORMATION AND CLASSES IN THE FIELD OF PHYSICAL EXERCISE (U.S. CLS. 100, 101 AND 107).

FIRST USE 0-0-1999; IN COMMERCE 0-0-1999.

JOHN DWYER, EXAMINING ATTORNEY

SN 85-383,855. MASSEY, LEONARD, WASHINGTON, DC.
FILED 7-28-2011.

VENUSPLUSX

THE MARK CONSISTS OF STANDARD CHARACTERS WITHOUT CLAIM TO ANY PARTICULAR FONT, STYLE, SIZE, OR COLOR.

FOR EDUCATION AND ENTERTAINMENT SERVICES, NAMELY, PROVIDING TRAINING AND SEMINARS IN THE FIELD OF LESBIAN, GAY, BISEXUAL, AND TRANSGENDER FREEDOMS AND PROTESTS (U.S. CLS. 100, 101 AND 107).

FIRST USE 7-10-2010; IN COMMERCE 2-2-2011.

BARBARA BROWN, EXAMINING ATTORNEY

SN 85-384,347. THE FERRARI GROUP, INC., LEXINGTON,
KY. FILED 7-29-2011.

**Etta May's White Trash
Diary**

THE MARK CONSISTS OF STANDARD CHARACTERS WITHOUT CLAIM TO ANY PARTICULAR FONT, STYLE, SIZE, OR COLOR.

OWNER OF U.S. REG. NOS. 3,041,498, 3,041,499 AND 3,041,502.

THE NAME(S), PORTRAIT(S), AND/OR SIGNATURE(S) SHOWN IN THE MARK IDENTIFIES "ETTA MAY", WHOSE CONSENT(S) TO REGISTER IS MADE OF RECORD.

FOR ENTERTAINMENT SERVICES IN THE NATURE OF COMEDY PRESENTATIONS, NAMELY, LIVE PERFORMANCES BY COMEDIANS; AND PROVIDING A WEB SITE FEATURING COMEDY ENTERTAINMENT AND COMEDY INFORMATION ON THE INTERNET (U.S. CLS. 100, 101 AND 107).

FIRST USE 7-20-2011; IN COMMERCE 7-20-2011.

SHAILA SETTLES, EXAMINING ATTORNEY

CLASS 41—(Continued).

SN 85-385,899. HILL, RUSSELL, BEACH HAVEN, NJ. FILED 8-1-2011.

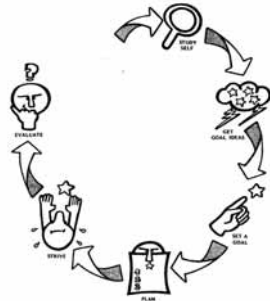

THE MARK CONSISTS OF A SERIES OF FIGURES ABOVE WORDS IN A CIRCULAR PATTERN, EACH SEPARATED BY A CURVED ARROW, GOING CLOCKWISE FROM THE TOP, THERE IS A MAGNIFYING GLASS ABOVE THE WORDS "STUDY SELF"; A CLOUD WITH FOUR STARS AND TWO LIGHTNING BOLTS ABOVE "GET GOAL IDEAS"; A HAND AND FINGER POINTING TO A STAR ABOVE "SET A GOAL"; A FACE PEERING ABOVE A PIECE OF PAPER WITH "1 2 3" ON IT, ABOVE "PLAN"; A FIGURE WITH OUTSTRETCHED ARMS, FOUR DROPLETS OF WATER NEXT TO ITS HEAD AND A STAR ABOVE "STRIVE"; AND A FACE RESTING ON A HAND UNDER A QUESTION MARK, ABOVE "EVALUATE".

FOR EDUCATIONAL SERVICES, NAMELY, CONDUCTING TRAINING SEMINARS, CONFERENCES, AND WORKSHOPS IN THE FIELD OF GENERAL ACADEMIC STUDIES WITH FOCUS ON GOAL SETTING AND ACHIEVEMENT BEHAVIORS FOR THE PURPOSE OF INCREASING PARTICIPANTS ACHIEVEMENT AND INTERNAL LOCUS OF CONTROL, AND THE DISTRIBUTION OF TRAINING MATERIALS IN CONNECTION THEREWITH (U.S. CLS. 100, 101 AND 107).

ELISSA GARBER KON, EXAMINING ATTORNEY

SN 85-386,838. PUSH ATHLETICS LLC, SAN FRANCISCO, CA. FILED 8-2-2011.

Push

THE MARK CONSISTS OF STANDARD CHARACTERS WITHOUT CLAIM TO ANY PARTICULAR FONT, STYLE, SIZE, OR COLOR.

FOR ON-LINE PUBLICATION OF MAGAZINES, NEWSLETTERS, NEWSPAPERS, BOOKS AND BOOKLETS IN THE FIELD OF EXERCISE AND FITNESS; PERSONAL FITNESS TRAINING SERVICES AND CONSULTANCY; PHYSICAL FITNESS CONDITIONING CLASSES; PHYSICAL FITNESS CONSULTATION; PHYSICAL FITNESS INSTRUCTION; PHYSICAL FITNESS TRAINING SERVICES; PROVIDING FITNESS AND EXERCISE FACILITIES (U.S. CLS. 100, 101 AND 107).

BARBARA A. GOLD, EXAMINING ATTORNEY

CLASS 41—(Continued).

SN 85-388,700. CREDIT UNION NATIONAL ASSOCIATION, INC., MADISON, WI. FILED 8-3-2011.

CREDIT UNION NATIONAL ASSOCIATION

THE MARK CONSISTS OF STANDARD CHARACTERS WITHOUT CLAIM TO ANY PARTICULAR FONT, STYLE, SIZE, OR COLOR.

SEC. 2(F).

FOR EDUCATION SERVICES, NAMELY, PROVIDING LIVE SEMINARS, CLASSES AND CONFERENCES IN THE FIELD OF CREDIT UNIONS; EDUCATION SERVICES, NAMELY, PROVIDING ON-LINE SEMINARS, CLASSES AND CONFERENCES IN THE FIELD OF CREDIT UNIONS; ONLINE NEWSLETTERS IN THE FIELD OF CREDIT UNION PROMOTION, BUSINESS AND EDUCATION (U.S. CLS. 100, 101 AND 107).

FIRST USE 7-30-1954; IN COMMERCE 7-30-1954.

ANDREA BUTLER, EXAMINING ATTORNEY

SN 85-391,795. THE SMITH ADVISORY GROUP, LLC, WESTFIELD, IN. FILED 8-8-2011.

Investing Sense

THE MARK CONSISTS OF STANDARD CHARACTERS WITHOUT CLAIM TO ANY PARTICULAR FONT, STYLE, SIZE, OR COLOR.

NO CLAIM IS MADE TO THE EXCLUSIVE RIGHT TO USE "INVESTING", APART FROM THE MARK AS SHOWN. FOR ENTERTAINMENT SERVICES, NAMELY, AN ON-GOING SERIES FEATURING A DISCUSSION OF FINANCIAL PLANNING AND INVESTMENT TOPICS PROVIDED THROUGH RADIO BROADCASTS (U.S. CLS. 100, 101 AND 107).

FIRST USE 10-25-2003; IN COMMERCE 10-25-2003.

MARC LEIPZIG, EXAMINING ATTORNEY

SN 85-393,155. BARNHORST, ZACHARY, LA JOLLA, CA. AND BARNHORST, NICHOLAS, LA JOLLA, CA. FILED 8-9-2011.

TURKATHLON

THE MARK CONSISTS OF STANDARD CHARACTERS WITHOUT CLAIM TO ANY PARTICULAR FONT, STYLE, SIZE, OR COLOR.

FOR ENTERTAINMENT IN THE NATURE OF ORGANIZING A RACE; ORGANIZATION OF SPORTS EVENTS IN THE FIELD OF TRIATHLONS; PROVISION OF INFORMATION RELATING TO SPORTS AND SPORTING EVENTS; ENTERTAINMENT IN THE NATURE OF TRIATHLONS; ORGANIZATION OF SPORTS COMPETITIONS (U.S. CLS. 100, 101 AND 107).

FIRST USE 11-27-2008; IN COMMERCE 11-27-2008.

RONALD AIKENS, EXAMINING ATTORNEY

CLASS 41—(Continued).

SN 85-393,598. REAVES, RAY, AUSTIN, TX. FILED 8-9-2011.



NO CLAIM IS MADE TO THE EXCLUSIVE RIGHT TO USE "AUSTIN MIND & BODY", APART FROM THE MARK AS SHOWN.

THE COLOR(S) LIGHT BLUE AND NAVY BLUE IS/ARE CLAIMED AS A FEATURE OF THE MARK.

THE MARK CONSISTS OF THE WORDING "AUSTINMB.COM", WHERE THE LETTER "T" IS FORMED BY STYLIZED REPRESENTATION OF A PERSON, AND THE STYLIZED PERSON AND THE LETTERS MB APPEAR IN NAVY BLUE, WHILE THE LETTERS "AUS IN" AND ".COM" APPEAR IN LIGHT BLUE. UNDERNEATH, THE WORDING "AUSTIN MIND & BODY" APPEARS IN LIGHT BLUE.

FOR PROVIDING ON-LINE E-ZINES IN THE FIELD OF MIND AND BODY (U.S. CLS. 100, 101 AND 107).
AMY ALFIERI, EXAMINING ATTORNEY

CLASS 41—(Continued).

SN 85-396,444. 2275701 ONTARIO INC., THORNHILL, ONTARIO, CANADA, FILED 8-12-2011.



NO CLAIM IS MADE TO THE EXCLUSIVE RIGHT TO USE "FILMS", APART FROM THE MARK AS SHOWN.

THE MARK CONSISTS OF THE WORDS "URBINDER FILMS" BELOW A CURVED ARC DESIGN.

FOR ENTERTAINMENT SERVICES, NAMELY, PRODUCTION AND DISTRIBUTION OF MOTION PICTURES (U.S. CLS. 100, 101 AND 107).

SUSAN RICHARDS, EXAMINING ATTORNEY

SN 85-397,524. THOMAS O'NEIL, LOS ANGELES, CA. FILED 8-14-2011.

TV Derby

THE MARK CONSISTS OF STANDARD CHARACTERS WITHOUT CLAIM TO ANY PARTICULAR FONT, STYLE, SIZE, OR COLOR.

NO CLAIM IS MADE TO THE EXCLUSIVE RIGHT TO USE "TV", APART FROM THE MARK AS SHOWN.

FOR PROVIDING A WEBSITE FEATURING ENTERTAINMENT INFORMATION (U.S. CLS. 100, 101 AND 107).

FIRST USE 11-30-2009; IN COMMERCE 11-30-2009.

KAPIL BHANOT, EXAMINING ATTORNEY

SN 85-395,958. SCHULTZ, STEPHEN, PITTSBURGH, PA. FILED 8-11-2011.

AMERICAN BAROQUE

THE MARK CONSISTS OF STANDARD CHARACTERS WITHOUT CLAIM TO ANY PARTICULAR FONT, STYLE, SIZE, OR COLOR.

NO CLAIM IS MADE TO THE EXCLUSIVE RIGHT TO USE "AMERICAN", APART FROM THE MARK AS SHOWN.

FOR ENTERTAINMENT RENDERED BY MUSICAL ARTISTS, NAMELY, ENTERTAINMENT IN THE NATURE OF VISUAL AND AUDIO PERFORMANCES BY A MUSICAL ACT; LIVE PERFORMANCES BY A MUSICAL ACT; MULTIMEDIA ENTERTAINMENT SERVICES IN THE NATURE OF RECORDING, PRODUCTION AND POST-PRODUCTION SERVICES IN THE FIELD OF MUSIC AND VIDEO; ENTERTAINMENT SERVICES BY A MUSICAL ARTIST, NAMELY, MUSICAL COMPOSITION AND PRODUCTION OF MUSICAL SOUND RECORDINGS; PROVIDING A WEB SITE FEATURING PRE-RECORDED MUSICAL AUDIO AND AUDIO-VISUAL CLIPS, PHOTOGRAPHS, NEWS, AND REVIEWS IN CONNECTION WITH A MUSICAL ACT; FAN CLUB SERVICES (U.S. CLS. 100, 101 AND 107).

FIRST USE 4-1-1989; IN COMMERCE 2-2-1990.

REGINA DRUMMOND, EXAMINING ATTORNEY

SN 85-402,954. PORTER, PATRICK, DUBLIN, CA. FILED 8-20-2011.

PATRICK PORTER

THE MARK CONSISTS OF STANDARD CHARACTERS WITHOUT CLAIM TO ANY PARTICULAR FONT, STYLE, SIZE, OR COLOR.

THE NAME(S), PORTRAIT(S), AND/OR SIGNATURE(S) SHOWN IN THE MARK IDENTIFIES "PATRICK PORTER", WHOSE CONSENT(S) TO REGISTER IS MADE OF RECORD.

FOR LIFE COACHING SERVICES IN THE FIELD OF WELLNESS AND STRESS REDUCTION (U.S. CLS. 100, 101 AND 107).

FIRST USE 4-1-1987; IN COMMERCE 4-1-1987.

SUNG IN, EXAMINING ATTORNEY

CLASS 41—(Continued).

SN 85-405,925. HARGROVE, MARILYN, SANTA FE, NM. FILED 8-24-2011.



THE COLOR(S) GREEN IS/ARE CLAIMED AS A FEATURE OF THE MARK.

THE MARK CONSISTS OF THE LITERAL ELEMENT "D" IN SMALL CASE WITH A DOT IN THE CENTRE IN GREEN COLOR AS SHOWN IN THE MARK.

FOR EDUCATIONAL SERVICES, NAMELY, PROVIDING ONLINE MEDITATION EXERCISES TO EDUCATE USERS ON HOW TO BETTER MANAGE THEIR NEGATIVE EMOTIONS AND TO BETTER ENJOY THEIR POSITIVE EMOTIONS (U.S. CLS. 100, 101 AND 107).

WILLIAM JACKSON, EXAMINING ATTORNEY

SN 85-406,805. COMPUTERS FOR YOUTH FOUNDATION, INC., NEW YORK, NY. FILED 8-25-2011.

POWERMYLEARNING

THE MARK CONSISTS OF STANDARD CHARACTERS WITHOUT CLAIM TO ANY PARTICULAR FONT, STYLE, SIZE, OR COLOR.

FOR PROVIDING A WEBSITE FEATURING EDUCATIONAL INFORMATION FOR THE PURPOSE OF ACADEMIC STUDY IN THE FIELD OF SUBJECTS TAUGHT IN PRE-SCHOOL AND GRADES K-12, WHICH ENABLES USERS TO SHARE THEIR OWN EDUCATIONAL RESOURCES WITH OTHER USERS, AND ENABLES USERS TO RATE, COMMENT UPON, AND MODIFY AVAILABLE EDUCATIONAL RESOURCES; PROVIDING AN INTERACTIVE WEBSITE FEATURING EDUCATIONAL INFORMATION FOR THE PURPOSE OF ACADEMIC STUDY IN THE FIELD OF SUBJECTS TAUGHT IN PRE-SCHOOL AND GRADES K-12 THAT ALLOWS USERS TO ASSIGN EDUCATIONAL RESOURCES TO STUDENTS AND MONITOR STUDENTS' PROGRESS; PROVIDING EDUCATIONAL INFORMATION FOR THE PURPOSE OF ACADEMIC STUDY IN THE FIELD OF SUBJECTS TAUGHT IN PRE-SCHOOL AND GRADES K-12, VIA BROADBAND DISTRIBUTION AND ONLINE WEB SITES (U.S. CLS. 100, 101 AND 107).

ALICIA COLLINS, EXAMINING ATTORNEY

CLASS 41—(Continued).

SN 85-410,374. BIRUTE REGINE, CAMBRIDGE, MA. FILED 8-30-2011.

IRON BUTTERFLIES

THE MARK CONSISTS OF STANDARD CHARACTERS WITHOUT CLAIM TO ANY PARTICULAR FONT, STYLE, SIZE, OR COLOR.

FOR ENTERTAINMENT AND EDUCATIONAL SERVICES, NAMELY, ORGANIZING AND HOSTING WORKSHOPS AND CONFERENCES AND PROVIDING TRAINING FOR CONVENERS IN THE FIELD OF ACCELERATING WOMEN'S LEADERSHIP SKILLS AND PERSONAL AND SOCIAL TRANSFORMATION (U.S. CLS. 100, 101 AND 107).

NORA BUCHANAN WILL, EXAMINING ATTORNEY

SN 85-415,441. ANCHONDO, ALDO, COLORADO SPRINGS, CO. AND ANCHONDO, DANIEL, COLORADO SPRINGS, CO. AND ANCHONDO, LEONEL, COLORADO SPRINGS, CO. FILED 9-6-2011.

D'vociion Norteña

THE MARK CONSISTS OF STANDARD CHARACTERS WITHOUT CLAIM TO ANY PARTICULAR FONT, STYLE, SIZE, OR COLOR.

THE ENGLISH TRANSLATION OF THE TERM "NORTEÑA" IS "NORTH". THE TERM "D'VOCIION" HAS NO MEANING IN A FOREIGN LANGUAGE.

FOR LIVE PERFORMANCES BY A MUSICAL GROUP (U.S. CLS. 100, 101 AND 107).

FIRST USE 1-1-2011; IN COMMERCE 1-1-2011.

EVELYN BRADLEY, EXAMINING ATTORNEY

SN 85-415,845. ARIZONA SWIMMING, INC., PHOENIX, AZ. FILED 9-6-2011.



NO CLAIM IS MADE TO THE EXCLUSIVE RIGHT TO USE "ARIZONA SWIMMING", APART FROM THE MARK AS SHOWN.

THE COLOR(S) RED, WHITE, AND BLUE IS/ARE CLAIMED AS A FEATURE OF THE MARK.

THE MARK CONSISTS OF THE SHAPE OF THE STATE OF ARIZONA OUTLINED IN BLUE WITH THE WORD "ARIZONA" IN BLUE CAPITAL LETTERS ALONG THE NORTHERN BORDER OF THE STATE SHAPE AND THE WORD "SWIMMING" IN BLUE CAPITAL LETTERS ALONG THE SOUTHERN BORDER OF THE STATE SHAPE.

CLASS 41—(Continued).

THERE IS A WHITE FIVE POINTED STAR OUTLINED IN BLUE POSITIONED SLIGHTLY TO THE RIGHT OF THE CENTER OF THE ARIZONA STATE SHAPE WITH THE TOPMOST POINT FALLING BELOW AND APPROXIMATELY BETWEEN THE "O" AND THE "N" OF "ARIZONA". FROM JUST BELOW THE TOP LEFT CORNER OF THE ARIZONA STATE SHAPE, THERE IS A BLUE FIGURE OF A HUMAN OUTLINED IN WHITE POSITIONED AS THOUGH DIVING DIAGONALLY DOWNWARD. THE HUMAN FIGURE'S FEET EXTEND JUST BEYOND THE NORTH WESTERN BORDER OF THE STATE AND THE CALVES OF THE HUMAN FIGURE ARE JUST BELOW THE "A" IN THE WORD "ARIZONA". THE HANDS OF THE HUMAN FIGURE ARE IN THE CENTER OF THE STAR. THE ARIZONA STATE SHAPE IS BISECTED BY TWO DISTINCT BACKGROUNDS ON THE TOP AND BOTTOM OF THE STATE SHAPE, RESPECTIVELY. THE BOTTOM HALF OF THE ARIZONA STATE SHAPE IS COLORED IN BLUE AND WHITE, GIVING THE IMPRESSION OF A BACKGROUND OF WATER OR WAVES. THE LOWER PORTION OF THE STAR IS IN FRONT OF THE BLUE BACKGROUND. THE TOP HALF OF THE ARIZONA STATE SHAPE IS COLORED WITH ALTERNATING RED AND WHITE DIAGONAL STRIPES RADIATING OUTWARD FROM THE STAR, GIVING THE IMPRESSION OF A BACKGROUND OF A RED AND WHITE STARBURST. THE UPPER PORTION OF THE STAR IS IN FRONT OF THE RED AND WHITE BACKGROUND.

FOR ORGANIZING, ARRANGING, AND CONDUCTING YOUTH SWIMMING MEET EVENTS (U.S. CLS. 100, 101 AND 107).

FIRST USE 5-4-2005; IN COMMERCE 5-4-2005.
JEFFERY COWARD, EXAMINING ATTORNEY

SN 85-416,737. TIPPING POINT ENERGY, INC., DUBLIN, OH. FILED 9-7-2011.

Solar By Soldiers

THE MARK CONSISTS OF STANDARD CHARACTERS WITHOUT CLAIM TO ANY PARTICULAR FONT, STYLE, SIZE, OR COLOR.

NO CLAIM IS MADE TO THE EXCLUSIVE RIGHT TO USE "SOLAR", APART FROM THE MARK AS SHOWN.

FOR PROVIDING TRAINING TO MILITARY VETERANS TO WORK ON SOLAR ENERGY PROJECTS (U.S. CLS. 100, 101 AND 107).

FIRST USE 8-16-2011; IN COMMERCE 8-16-2011.
TIMOTHY FINNEGAN, EXAMINING ATTORNEY

CLASS 41—(Continued).

SN 85-419,534. FOCUS POINT LABS, LLC, NEWPORT BEACH, CA. FILED 9-10-2011.

WAKE STATE

THE MARK CONSISTS OF STANDARD CHARACTERS WITHOUT CLAIM TO ANY PARTICULAR FONT, STYLE, SIZE, OR COLOR.

FOR DIGITAL VIDEO, AUDIO, AND MULTIMEDIA PUBLISHING SERVICES; PRODUCTION AND DISTRIBUTION OF INDEPENDENT MOTION PICTURES; PRODUCTION OF DVDS, VIDEOTAPES AND TELEVISION PROGRAMS FEATURING MUSIC, SPORTS AND LIFESTYLE SUBJECTS; PRODUCTION OF MUSICAL VIDEOS (U.S. CLS. 100, 101 AND 107).

SARA BENJAMIN, EXAMINING ATTORNEY

SN 85-421,014. GWO, TAE & GAY L.L.C., PHILADELPHIA, PA. FILED 9-13-2011.

PROGRESS YOURSELF

THE MARK CONSISTS OF STANDARD CHARACTERS WITHOUT CLAIM TO ANY PARTICULAR FONT, STYLE, SIZE, OR COLOR.

FOR PROVIDING A WEBSITE FEATURING NON-DOWNLOADABLE INSTRUCTIONAL VIDEO RECORDINGS IN DIGITAL FORMAT FEATURING THE TOPIC OF FITNESS IN THE NATURE OF EXERCISE THERAPY (U.S. CLS. 100, 101 AND 107).

ANDREA K. NADELMAN, EXAMINING ATTORNEY

SN 85-421,177. CORRELL, BROOKE, CHARLOTTESVILLE, VA. FILED 9-13-2011.

NO CLAIM IS MADE TO THE EXCLUSIVE RIGHT TO USE "SLOGA", APART FROM THE MARK AS SHOWN.

THE COLOR(S) BLUE, GRAY AND LIGHT YELLOW IS/ARE CLAIMED AS A FEATURE OF THE MARK.

THE MARK CONSISTS OF THE WORD "SLOGA" WITH THE "SL" AND PART OF THE LETTER "O" IN BLUE STYLIZED FONT WITH A GRAY CURVED LINE CUTTING THROUGH THE CENTER OF THE "O"; THE OTHER SIDE OF THE "O" AS WELL AS THE LETTERS "GA" ARE IN A LIGHT YELLOW STYLIZED FONT.

FOR YOGA INSTRUCTION (U.S. CLS. 100, 101 AND 107).

FIRST USE 3-0-2010; IN COMMERCE 3-0-2010.
KATHERINE E. HALMEN, EXAMINING ATTORNEY

CLASS 41—(Continued).

SN 85-421,780. TIM CAMP, LINESVILLE, PA. FILED 9-13-2011.



NO CLAIM IS MADE TO THE EXCLUSIVE RIGHT TO USE "BAND", APART FROM THE MARK AS SHOWN.

THE MARK CONSISTS OF THE WORDS "SOFA KING" PRINTED IN A STYLIZED FONT ACROSS THE CENTER OF A LARGE OVAL; THE WORD "THE" IS PRINTED ABOVE THE "O" OF "SOFA" IN A SQUARE FONT; THE WORDS "COOL BAND" ARE PRINTED WITH THE SQUARE FONT IN A SMALLER FONT SIZE BENEATH "SOFA KING"; A FANCIFUL DEPICTION OF A SOFA HAVING A DIP IN THE CENTER OF THE BACK SITS ABOVE THE CENTER LINE OF THE OVAL EXTENDING OUTSIDE THE OVAL; A STYLIZED CROWN IS POSITIONED ABOVE THE DIP OF THE SOFA BACK AND TILTED SLIGHTLY TO THE LEFT.

FOR ENTERTAINMENT SERVICES IN THE NATURE OF PRESENTING LIVE MUSICAL PERFORMANCES (U.S. CLS. 100, 101 AND 107).

FIRST USE 7-29-2011; IN COMMERCE 7-29-2011.
ANNE FARRELL, EXAMINING ATTORNEY

CLASS 41—(Continued).

SN 85-422,437. FREMANTLEMEDIA LIMITED, LONDON, ENGLAND, FILED 9-14-2011.

TREE FU TOM

THE MARK CONSISTS OF STANDARD CHARACTERS WITHOUT CLAIM TO ANY PARTICULAR FONT, STYLE, SIZE, OR COLOR.

PRIORITY CLAIMED UNDER SEC. 44(D) ON ERPN CMNTY TM OFC APPLICATION NO. 009871443, FILED 4-6-2011, REG. NO. 009871443, DATED 8-22-2011, EXPIRES 4-6-2021.

FOR ENTERTAINMENT AND EDUCATION SERVICES, NAMELY, AN ONGOING CHILDREN'S MULTIPLATFORM FANTASY ANIMATION ADVENTURE SERIES; ENTERTAINMENT, EDUCATION AND INSTRUCTION BY OR RELATING TO RADIO AND TELEVISION, NAMELY, A CHILDREN'S MULTIPLATFORM FANTASY ANIMATION ADVENTURE SERIES; PRODUCTION, PRESENTATION AND RENTAL OF TELEVISION AND RADIO PROGRAMS AND OF FILMS AND SOUND AND VIDEO RECORDINGS; ENTERTAINMENT, EDUCATION AND INSTRUCTION FOR CHILDREN, NAMELY, PRODUCTION AND DISTRIBUTION OF ONGOING TELEVISION PROGRAMS IN THE FIELD OF CHILDREN'S ENTERTAINMENT; ORGANIZATION COMPETITIONS, GAMES, QUIZZES, FUN DAYS, AND SPORTING EVENTS FOR EDUCATIONAL AND ENTERTAINMENT PURPOSES; ORGANIZATION, PRESENTATION AND PRODUCTION OF SHOWS, LIVE PERFORMANCES AND AUDIENCE PARTICIPATION EVENT FOR EDUCATIONAL AND ENTERTAINMENT PURPOSES; PROVISION OF NON-DOWNLOADABLE GAMES VIA MOBILE OR COMPUTER NETWORKS; PROVISION OF NON-DOWNLOADABLE INTERACTIVE VOICE RECOGNITION GAMES AND ENTERTAINMENT COMPETITIONS; OPERATION OF LOTTERY AND GAMES OF CHANCE; PROVISION OF VIDEO CLIPS VIA MOBILE AND COMPUTER NETWORKS FOR ENTERTAINMENT AND/OR EDUCATIONAL PURPOSES IN THE FIELD OF CHILDREN'S ENTERTAINMENT; PROVIDING AN INTERNET WEBSITE FEATURING INFORMATION RELATING TO A TELEVISION COMEDY SERIES (U.S. CLS. 100, 101 AND 107).
MARK RADEMACHER, EXAMINING ATTORNEY

SN 85-422,943. MCCONVILLE, SHANNON, CHESTERFIELD, VA. FILED 9-14-2011.

Stavna Ballet

THE MARK CONSISTS OF STANDARD CHARACTERS WITHOUT CLAIM TO ANY PARTICULAR FONT, STYLE, SIZE, OR COLOR.

NO CLAIM IS MADE TO THE EXCLUSIVE RIGHT TO USE "BALLET", APART FROM THE MARK AS SHOWN.

FOR DANCE INSTRUCTION; ENTERTAINMENT IN THE NATURE OF DANCE PERFORMANCES (U.S. CLS. 100, 101 AND 107).

FIRST USE 12-1-2010; IN COMMERCE 1-5-2011.
RAMONA ORTIGA, EXAMINING ATTORNEY

CLASS 41—(Continued).

SN 85-427,315. KNOWLES, CRAIG, SNEVILLE, GA. FILED 9-20-2011.

KINESIOMUSCULAR THERAPY

THE MARK CONSISTS OF STANDARD CHARACTERS WITHOUT CLAIM TO ANY PARTICULAR FONT, STYLE, SIZE, OR COLOR.

NO CLAIM IS MADE TO THE EXCLUSIVE RIGHT TO USE "THERAPY", APART FROM THE MARK AS SHOWN. FOR INFORMATION IN THE FIELD OF MASSAGE THERAPY (U.S. CLS. 100, 101 AND 107).

FIRST USE 1-15-2011; IN COMMERCE 1-15-2011.
ERNEST SHOSHO, EXAMINING ATTORNEY

CLASS 41—(Continued).

SN 85-428,425. RODRIGUEZ, RODNEY J., FREEPORT, NY. FILED 9-21-2011.

The logo for "AEROSOULS" features the word "AEROSOULS" in a stylized, graffiti-like font. The letter "O" in "AERO" is replaced by a circular graphic that resembles a spray can nozzle.

THE MARK CONSISTS OF "AEROSOULS"- IS A PLAY ON WORDS. IT IS ANOTHER WAY OF WRITING AEROSOLS. THE SECOND PART OF THE WORD "SOULS" IS DEPICTED IN A GRAFFITI STYLE FONT. THE "O" IN "AERO" HAS AN AEROSOL (SPRAY) CAN ON IT.

FOR ENTERTAINMENT SERVICES, NAMELY, AN ON-GOING SERIES FEATURING AEROSOL AND GRAFFITI ARTISTS PROVIDED THROUGH TELEVISION (U.S. CLS. 100, 101 AND 107).

TEJBIR SINGH, EXAMINING ATTORNEY

SN 85-428,100. HALL, RAYMOND LEWIS, LAS VEGAS, NV. FILED 9-21-2011.

THE NEXT FEMALE SUPERSTAR

THE MARK CONSISTS OF STANDARD CHARACTERS WITHOUT CLAIM TO ANY PARTICULAR FONT, STYLE, SIZE, OR COLOR.

NO CLAIM IS MADE TO THE EXCLUSIVE RIGHT TO USE "FEMALE SUPERSTAR", APART FROM THE MARK AS SHOWN.

FOR ENTERTAINMENT IN THE NATURE OF AN ON-GOING SPECIAL VARIETY, NEWS, MUSIC OR COMEDY SHOW FEATURING MUSIC COMPETITION BROADCAST OVER TELEVISION, SATELLITE, AUDIO, AND VIDEO MEDIA; ENTERTAINMENT IN THE NATURE OF VISUAL AND AUDIO PERFORMANCES, AND MUSICAL, VARIETY, NEWS AND COMEDY SHOWS; ENTERTAINMENT SERVICES IN THE NATURE OF AN ON-GOING REALITY BASED TELEVISION PROGRAM; ENTERTAINMENT SERVICES, NAMELY, PERSONAL APPEARANCES BY A CELEBRITY AND POP MUSIC ACTS (U.S. CLS. 100, 101 AND 107).

FIRST USE 1-0-2011; IN COMMERCE 1-0-2011.
TRACY FLETCHER, EXAMINING ATTORNEY

SN 85-432,881. KNITTING FEVER, INC., AMITYVILLE, NY. FILED 9-27-2011.

The logo for "Yarnologue" features the word "Yarnologue" in a large, elegant, serif font.

THE MARK CONSISTS OF STANDARD CHARACTERS WITHOUT CLAIM TO ANY PARTICULAR FONT, STYLE, SIZE, OR COLOR.

FOR ON-LINE JOURNALS, NAMELY, BLOGS FEATURING INFORMATION ON YARN, KNITTING AND FASHION (U.S. CLS. 100, 101 AND 107).

FIRST USE 9-15-2011; IN COMMERCE 9-15-2011.
BENJAMIN OKEKE, EXAMINING ATTORNEY

CLASS 41—(Continued).

SN 85-435,265. NETWORK SEARCH INCORPORATED, CHICAGO, IL. FILED 9-29-2011.



NO CLAIM IS MADE TO THE EXCLUSIVE RIGHT TO USE "CORPORATE", APART FROM THE MARK AS SHOWN.

THE COLOR(S) BROWN AND GRAY IS/ARE CLAIMED AS A FEATURE OF THE MARK.

THE MARK CONSISTS OF THE WORDS "CORPORATE BOARDLINK" WRITTEN IN A STYLIZED MANNER, WITH THE WORDS "CORPORATE" AND "BOARD" IN BROWN AND THE WORD "LINK" IN GRAY. THE "R" IN THE WORD "BOARD" EXTENDS BELOW AND CURVES UNDER THE REMAINDER OF THE WORD "BOARDLINK".

FOR BUSINESS EDUCATION AND TRAINING SERVICES, NAMELY, DEVELOPING AND FACILITATING CUSTOMIZED LEADERSHIP AND EXECUTIVE DEVELOPMENT PROGRAMS, PROVIDING EXECUTIVE COACHING SERVICES, AND PROVIDING BUSINESS EDUCATION PROGRAMS TO EMPLOYEES AND EXECUTIVES (U.S. CLS. 100, 101 AND 107).

FIRST USE 9-1-2008; IN COMMERCE 9-1-2008.
JOHN DALIER, EXAMINING ATTORNEY

CLASS 41—(Continued).

SN 85-435,797. ALBRECHT, KATE, DBA MR. KATE, LOS ANGELES, CA. FILED 9-29-2011.



THE NAME(S), PORTRAIT(S), AND/OR SIGNATURE(S) SHOWN IN THE MARK IDENTIFIES KATE MACKENZIE ALBRECHT, WHOSE CONSENT(S) TO REGISTER IS MADE OF RECORD.

THE MARK CONSISTS OF THE WORDS "MR. KATE" OVER THE IMAGE OF A MUSTACHE, WITH THE PERIOD AFTER "MR" BEING REPRESENTED BY A BEAUTY MARK.

FOR PROVIDING WRITTEN BLOGS AND NON-DOWNLOADABLE VIDEO BLOGS FEATURING INFORMATION, TUTORIALS AND ADVICE IN THE FIELDS OF FASHION, HOME DECORATING, FOOD, HEALTH, TRAVEL, AND PERSONAL GROWTH (U.S. CLS. 100, 101 AND 107).

FIRST USE 2-15-2011; IN COMMERCE 2-15-2011.
MARK RADEMACHER, EXAMINING ATTORNEY

SN 85-435,390. ROMANO, CARINA, DBA CARINA ROMANO PHOTOGRAPHY, PHILADELPHIA, PA. FILED 9-29-2011.

Love Me Do Photography

THE MARK CONSISTS OF STANDARD CHARACTERS WITHOUT CLAIM TO ANY PARTICULAR FONT, STYLE, SIZE, OR COLOR.

NO CLAIM IS MADE TO THE EXCLUSIVE RIGHT TO USE PHOTOGRAPHY, APART FROM THE MARK AS SHOWN.

FOR PHOTOGRAPHY; PHOTOGRAPHY SERVICES; PORTRAIT PHOTOGRAPHY; WEDDING PHOTOGRAPHY SERVICES (U.S. CLS. 100, 101 AND 107).

FIRST USE 9-1-2008; IN COMMERCE 9-1-2008.
LESLEY LAMOTHE, EXAMINING ATTORNEY

SN 85-435,831. ALBRECHT, KATE, DBA MR. KATE, LOS ANGELES, CA. FILED 9-29-2011.

MR. KATE

THE MARK CONSISTS OF STANDARD CHARACTERS WITHOUT CLAIM TO ANY PARTICULAR FONT, STYLE, SIZE, OR COLOR.

THE NAME(S), PORTRAIT(S), AND/OR SIGNATURE(S) SHOWN IN THE MARK IDENTIFIES KATE MACKENZIE ALBRECHT, WHOSE CONSENT(S) TO REGISTER IS MADE OF RECORD.

FOR PROVIDING WRITTEN BLOGS AND NON-DOWNLOADABLE VIDEO BLOGS FEATURING INFORMATION, TUTORIALS AND ADVICE IN THE FIELDS OF FASHION, HOME DECORATING, FOOD, HEALTH, TRAVEL, AND PERSONAL GROWTH (U.S. CLS. 100, 101 AND 107).

FIRST USE 6-10-2009; IN COMMERCE 6-10-2009.
MARK RADEMACHER, EXAMINING ATTORNEY

CLASS 41—(Continued).

SN 85-435,964. SEMPION, INC, NEW YORK, NY. FILED 9-30-2011.



NO CLAIM IS MADE TO THE EXCLUSIVE RIGHT TO USE "MUSIC FOR MOVIES", APART FROM THE MARK AS SHOWN.

THE MARK CONSISTS OF THE WORD "MUSIC" TO THE RIGHT OF THAT IS THE NUMBER "4", CENTERED BELOW THAT IS THE WORD "MOVIES" WITH THE LETTER "O" BEING A FILM REEL, CENTERED BELOW THAT IS "SOUNDS LIKE A GOOD MOVIE!"

FOR PROVIDING AN ONLINE SEARCHABLE DATABASE IN THE FIELD OF MUSIC AND MOVIES FEATURING A DIRECTORY OF FILMMAKERS, PRODUCERS, DIRECTORS, AGENTS, FILM COMPOSERS, TELEVISION COMPOSERS, SOUND DESIGNERS, SONGWRITERS, PRE-RECORDED SONGS AND MUSIC, SOUND EDITORS, SOUND ENGINEERS, SOUND RECORDISTS, MUSIC SUPERVISORS, MUSIC PUBLISHERS, AND VOICEOVER ARTISTS (U.S. CLS. 100, 101 AND 107).

FIRST USE 8-1-2011; IN COMMERCE 8-1-2011.
GRETTA YAO, EXAMINING ATTORNEY

CLASS 41—(Continued).

SN 85-436,950. JERRY BROOKS, AKA JB SMOOVE, BEVERLY HILLS, CA. FILED 9-30-2011.



NO CLAIM IS MADE TO THE EXCLUSIVE RIGHT TO USE "PRODUCTIONS", APART FROM THE MARK AS SHOWN.

THE MARK CONSISTS OF THE WORDS "FOUR SQUARE MILES" ABOVE THE WORD "PRODUCTIONS" ALL OF WHICH ARE UNDER THE NUMBER "4" WHICH HAS THE NUMBER "2" SUPERIMPOSED. A SEMI-CIRCULAR DESIGN EXTENDS FROM THE NUMBER "4" AND CONTINUES UNDER THE WORD ELEMENTS, ENDING IN A CIRCLE DESIGN.

FOR ENTERTAINMENT IN THE NATURE OF LIVE MUSICAL PERFORMANCES, DRAMATIC PERFORMANCES AND COMEDIC PERFORMANCES; MUSIC VIDEO PRODUCTION; PRODUCTION OF SOUND AND MUSIC VIDEO RECORDINGS; MULTIMEDIA ENTERTAINMENT SERVICES IN THE NATURE OF RECORDING, PRODUCTION AND POST-PRODUCTION SERVICES IN THE FIELDS OF MUSIC, VIDEO AND FILM; ENTERTAINMENT SERVICES, NAMELY, PROVIDING ON-GOING WEBISODES FEATURING MUSIC, COMEDY AND DRAMA VIA A GLOBAL COMPUTER NETWORK (U.S. CLS. 100, 101 AND 107).

AMY C. KEAN, EXAMINING ATTORNEY

SN 85-436,889. PIEROT-CRAWFORD, DEBORAH, RICHARDSON, TX. FILED 9-30-2011.

Singing Pierot Family

THE MARK CONSISTS OF STANDARD CHARACTERS WITHOUT CLAIM TO ANY PARTICULAR FONT, STYLE, SIZE, OR COLOR.

NO CLAIM IS MADE TO THE EXCLUSIVE RIGHT TO USE "SINGING", APART FROM THE MARK AS SHOWN. SEC. 2(F).

FOR ENTERTAINMENT SERVICES IN THE NATURE OF LIVE MUSICAL PERFORMANCES (U.S. CLS. 100, 101 AND 107).

FIRST USE 8-1-1970; IN COMMERCE 9-1-1970.
DAVID C. REIHNER, EXAMINING ATTORNEY

SN 85-437,372. M. DAVIS & ASSOCIATES CAPITAL INC., VANCOUVER, CANADA, FILED 10-3-2011.

The Five-to-One Fitness Formula

THE MARK CONSISTS OF STANDARD CHARACTERS WITHOUT CLAIM TO ANY PARTICULAR FONT, STYLE, SIZE, OR COLOR.

NO CLAIM IS MADE TO THE EXCLUSIVE RIGHT TO USE "FITNESS", APART FROM THE MARK AS SHOWN.

FOR PHYSICAL FITNESS CONSULTATION (U.S. CLS. 100, 101 AND 107).

TEJBIR SINGH, EXAMINING ATTORNEY

CLASS 41—(Continued).

SN 85-438,026. CAFE N PLAY, INC, NAPERVILLE, IL. FILED 10-3-2011.



NO CLAIM IS MADE TO THE EXCLUSIVE RIGHT TO USE "NAPERVILLE" AND "CAFE" AND "PLAY", APART FROM THE MARK AS SHOWN.

THE COLOR(S) BLACK, WHITE, AQUA, YELLOW AND ORANGE IS/ARE CLAIMED AS A FEATURE OF THE MARK.

THE MARK CONSISTS OF FIVE OUTLINED AQUA BUBBLES COMING FROM A YELLOW BUBBLE WAND AND A BLACK CIRCULAR BACKGROUND WITH A WHITE COFFEE CUP WITH A BLACK OVAL IN THE CENTER FROM WHICH THE YELLOW BUBBLE WAND IS PLACED. THE WHITE AREAS OF THE BUBBLES ARE TRANSPARENT AREAS AND ARE NOT CLAIMED AS FEATURES OF THE MARK. THE WHITE COFFEE CUP HAS THE WORD "NAPERVILLE" IN BLACK BLOCK LETTERS, FOLLOWED BY THE WORD "MOMS" IN AQUA SCRIPT LETTERS, WHICH IS FOLLOWED BY THE WORD "NETWORK" IN BLACK BLOCK LETTERS. UNDER THE WHITE COFFEE CUP, BUT STILL WITHIN PORTIONS OF THE BLACK CIRCLE, IS AN ORANGE AND AQUA BANNER WITH THE WORD "CAFE" IN WHITE LETTERS, THE LETTER "N" IN AQUA AND THE WORD "PLAY" IN WHITE LETTERS. BELOW THE BLACK CIRCLE IS THE PHRASE "THE PLACE WHERE MOMS & KIDS CONNECT" IN YELLOW LETTERING IN A SEMICIRCLE.

FOR CHILDREN'S ENTERTAINMENT AND AMUSEMENT CENTERS, NAMELY, INTERACTIVE PLAY AREAS; PROVIDING CHILDREN'S PARTY CENTERS FOR THE PURPOSE OF ENTERTAINING CHILDREN AND CELEBRATING BIRTHDAYS; PROVIDING RECREATIONAL AREAS IN THE NATURE OF PLAY AREAS FOR CHILDREN (U.S. CLS. 100, 101 AND 107).
BRENDAN MCCAULEY, EXAMINING ATTORNEY

SN 85-438,514. HARPER, JASON, SACRAMENTO, CA. FILED 10-4-2011.

Character Combine

THE MARK CONSISTS OF STANDARD CHARACTERS WITHOUT CLAIM TO ANY PARTICULAR FONT, STYLE, SIZE, OR COLOR.

NO CLAIM IS MADE TO THE EXCLUSIVE RIGHT TO USE "CHARACTER", APART FROM THE MARK AS SHOWN.

FOR EDUCATIONAL SERVICES, NAMELY, CONDUCTING CONFERENCES IN THE FIELD OF INCREASING CHARACTER AND INTEGRITY AMONG COACHES AND STUDENT ATHLETES (U.S. CLS. 100, 101 AND 107).

FIRST USE 5-1-2004; IN COMMERCE 5-1-2004.

KATHLEEN KOLACZ, EXAMINING ATTORNEY

CLASS 41—(Continued).

SN 85-438,530. ELIZA PORTRAIT DESIGN LLC, OMAHA, NE. FILED 10-4-2011.

Sexy Lil Photography

THE MARK CONSISTS OF STANDARD CHARACTERS WITHOUT CLAIM TO ANY PARTICULAR FONT, STYLE, SIZE, OR COLOR.

NO CLAIM IS MADE TO THE EXCLUSIVE RIGHT TO USE "PHOTOGRAPHY", APART FROM THE MARK AS SHOWN.

FOR PHOTOGRAPHY SERVICES (U.S. CLS. 100, 101 AND 107).

FIRST USE 4-1-2007; IN COMMERCE 4-1-2007.

GENE MACIOL, EXAMINING ATTORNEY

SN 85-438,642. SCOTT HERMAN FITNESS LLC, SALEM, NH. FILED 10-4-2011.

SCOTT HERMAN FITNESS

THE MARK CONSISTS OF STANDARD CHARACTERS WITHOUT CLAIM TO ANY PARTICULAR FONT, STYLE, SIZE, OR COLOR.

NO CLAIM IS MADE TO THE EXCLUSIVE RIGHT TO USE "FITNESS", APART FROM THE MARK AS SHOWN.

THE NAME(S), PORTRAIT(S), AND/OR SIGNATURE(S) SHOWN IN THE MARK IDENTIFIES "SCOTT HERMAN", WHOSE CONSENT(S) TO REGISTER IS MADE OF RECORD.

FOR CONSULTING SERVICES IN THE FIELDS OF FITNESS AND EXERCISE; COUNSELING SERVICES IN THE FIELD OF PHYSICAL FITNESS; PERSONAL FITNESS TRAINING SERVICES AND CONSULTANCY; PHYSICAL FITNESS INSTRUCTION; PROVIDING A WEB SITE FEATURING INFORMATION ON EXERCISE AND FITNESS; PROVIDING A WEBSITE FEATURING ONLINE SPORTS TRAINING AND TRAINING ADVICE AND THE RECORDING OF TRAINING AND WORK-OUTS; PROVIDING AN INTERACTIVE WEBSITE FEATURING INFORMATION AND LINKS RELATING TO FITNESS; PROVIDING AN ON-LINE COMPUTER DATABASE FEATURING INFORMATION REGARDING EXERCISE AND FITNESS (U.S. CLS. 100, 101 AND 107).

FIRST USE 9-1-2007; IN COMMERCE 9-1-2007.

IRA J. GOODSaid, EXAMINING ATTORNEY

CLASS 41—(Continued).

SN 85-440,786. BRAMMO, INC., ASHLAND, OR. FILED 10-6-2011.

BRAMMOPARX

THE MARK CONSISTS OF STANDARD CHARACTERS WITHOUT CLAIM TO ANY PARTICULAR FONT, STYLE, SIZE, OR COLOR.

OWNER OF U.S. REG. NO. 3,831,681.
FOR ENTERTAINMENT IN THE NATURE OF A MOTORCYCLE PARK; PROVIDING FACILITIES FOR MOTORCYCLING (U.S. CLS. 100, 101 AND 107).
HELENE LIWINSKI, EXAMINING ATTORNEY

SN 85-441,067. AMERICAN THEOLOGICAL LIBRARY ASSOCIATION, CHICAGO, IL. FILED 10-6-2011.

**ATLA CATHOLIC PERIODICAL
AND LITERATURE INDEX**

THE MARK CONSISTS OF STANDARD CHARACTERS WITHOUT CLAIM TO ANY PARTICULAR FONT, STYLE, SIZE, OR COLOR.

OWNER OF U.S. REG. NOS. 2,240,601, 2,938,062 AND OTHERS.

NO CLAIM IS MADE TO THE EXCLUSIVE RIGHT TO USE "PERIODICAL AND LITERATURE INDEX", APART FROM THE MARK AS SHOWN.

SEC. 2(F) "CATHOLIC PERIODICAL AND LITERATURE INDEX".

FOR PROVIDING AN ONLINE ELECTRONIC COMPUTER DATABASE FEATURING EDUCATIONAL INFORMATION IN THE ACADEMIC FIELD OF RELIGION, NAMELY, AN INDEX OF RELIGIOUS WRITINGS AND ABSTRACTS THEREOF VIA A GLOBAL COMPUTER NETWORK (U.S. CLS. 100, 101 AND 107).

FIRST USE 9-1-2011; IN COMMERCE 9-1-2011.
APRIL ROACH, EXAMINING ATTORNEY

SN 85-441,394. MRS. D'S PHOTOGRAPHY, LLC, SEARCY, AR. FILED 10-6-2011.

MRS. D'S PHOTOGRAPHY

THE MARK CONSISTS OF STANDARD CHARACTERS WITHOUT CLAIM TO ANY PARTICULAR FONT, STYLE, SIZE, OR COLOR.

NO CLAIM IS MADE TO THE EXCLUSIVE RIGHT TO USE "PHOTOGRAPHY", APART FROM THE MARK AS SHOWN.

FOR PHOTOGRAPHY SERVICES (U.S. CLS. 100, 101 AND 107).

WON TEAK OH, EXAMINING ATTORNEY

CLASS 41—(Continued).

SN 85-441,636. INTERNATIONAL SOCIETY OF RADIOLOGY, INC., BETHESDA, MD. FILED 10-7-2011.



NO CLAIM IS MADE TO THE EXCLUSIVE RIGHT TO USE "GLOBAL OUTREACH RADIOLOGY", APART FROM THE MARK AS SHOWN.

THE MARK CONSISTS OF THE WORDING "GORAD GLOBAL OUTREACH RADIOLOGY ISR" AND DESIGN ELEMENTS. THE LETTER "O" IN "GORAD" IS FORMED BY A GLOBE, AND A BAND APPEARS TO ENCIRCLE THE WORD "GORAD". BENEATH THAT APPEAR THE WORDS "GLOBAL OUTREACH RADIOLOGY", AND BENEATH THAT THE LETTERS "ISR". ALL OF THE WORDING APPEARS IN A SHADED OVAL WITH A LIGHTER SHADED OUTER BAND. THE COLOR WHITE IN THE DRAWING REPRESENTS BACKGROUND AND IS NOT PART OF THE MARK.

FOR PUBLISHING OF ELECTRONIC PUBLICATIONS IN THE FIELD OF RADIOLOGY; NON-DOWNLOADABLE ONLINE ELECTRONIC NEWSLETTERS DELIVERED BY E-MAIL IN THE FIELD OF RADIOLOGY (U.S. CLS. 100, 101 AND 107).

FIRST USE 6-0-2010; IN COMMERCE 6-0-2010.
EMILY CHUO, EXAMINING ATTORNEY

SN 85-441,637. UPRISING, INC., BOWLING GREEN, KY. FILED 10-7-2011.

REUP

THE MARK CONSISTS OF STANDARD CHARACTERS WITHOUT CLAIM TO ANY PARTICULAR FONT, STYLE, SIZE, OR COLOR.

FOR RELIGIOUS INSTRUCTION SERVICES IN THE FIELD OF RELIGIOUS MINISTRY SERVICES AND RELIGION FOR MEN; EDUCATIONAL AND ENTERTAINMENT SERVICES, NAMELY, PROVIDING MOTIVATIONAL SPEAKING SERVICES IN THE FIELD OF RELIGIOUS MINISTRY SERVICES AND RELIGION FOR MEN (U.S. CLS. 100, 101 AND 107).

MICHAEL GAFFAR, EXAMINING ATTORNEY

CLASS 41—(Continued).

SN 85-441,662. DESANTO, THOMAS, CORONADO, CA. FILED 10-7-2011.

Healthcare Contrarian

THE MARK CONSISTS OF STANDARD CHARACTERS WITHOUT CLAIM TO ANY PARTICULAR FONT, STYLE, SIZE, OR COLOR.

NO CLAIM IS MADE TO THE EXCLUSIVE RIGHT TO USE "HEALTHCARE", APART FROM THE MARK AS SHOWN.

FOR EDUCATIONAL SERVICES, NAMELY, PROVIDING EDUCATIONAL SPEAKERS IN THE FIELD OF HEALTHCARE; ON-LINE JOURNALS, NAMELY, BLOGS FEATURING COMMENTARY ON ALL ASPECTS OF HEALTHCARE; PROVIDING ON-LINE NEWSLETTERS IN THE FIELD OF HEALTHCARE; SCRIPTWRITING SERVICES; TRAINING COURSES IN STRATEGIC PLANNING RELATING TO ADVERTISING, PROMOTION, MARKETING AND BUSINESS; WRITING OF TEXTS OTHER THAN PUBLICITY TEXTS (U.S. CLS. 100, 101 AND 107).

APRIL ROACH, EXAMINING ATTORNEY

SN 85-441,790. PAULUS, HELEN, DBA OUT OF THE BOX INSTITUTE, ALLENTOWN, PA. FILED 10-7-2011.

OUT OF THE BOX INSTITUTE

THE MARK CONSISTS OF STANDARD CHARACTERS WITHOUT CLAIM TO ANY PARTICULAR FONT, STYLE, SIZE, OR COLOR.

NO CLAIM IS MADE TO THE EXCLUSIVE RIGHT TO USE "INSTITUTE", APART FROM THE MARK AS SHOWN.

FOR CLASSES, TELECOURSES, AND SEMINARS IN THE FIELD OF PERSONAL DEVELOPMENT, BEHAVIOR, LIFE BALANCE AND NAVIGATION (U.S. CLS. 100, 101 AND 107).

FIRST USE 0-0-2000; IN COMMERCE 0-0-2000.
SEAN CROWLEY, EXAMINING ATTORNEY

CLASS 41—(Continued).

SN 85-441,965. SOUND VIDEO PRODUCTIONS, LLC, CUYA-HOGA FALLS, OH. FILED 10-7-2011.



THE MARK CONSISTS OF THE STYLIZED WORD "BUGGITY". THE LETTERS "GG" HAVE EYEGLASS FRAMES WITH VISIBLE EYES AND BELOW EACH "G" ARE THREE LINES DEPICTING A MOUTH SPEAKING; THE GLASSES HAVE EAR PIECES THAT EXTEND DIAGONALLY UPWARD AND TO THE LEFT.

FOR VIDEOGRAPHY SERVICES (U.S. CLS. 100, 101 AND 107).

FIRST USE 7-15-2009; IN COMMERCE 9-1-2011.

LINDA MICKLEBURGH, EXAMINING ATTORNEY

SN 85-442,340. NEAL, ALFRED M., ST. PETERSBURG, FL. FILED 10-7-2011.

element- tao

THE MARK CONSISTS OF STANDARD CHARACTERS WITHOUT CLAIM TO ANY PARTICULAR FONT, STYLE, SIZE, OR COLOR.

FOR PROVIDING A WEBSITE FEATURING BLOGS AND NON-DOWNLOADABLE PUBLICATIONS IN THE NATURE OF ARTICLES, BROCHURES, BOOKS AND MAGAZINES IN THE FIELDS OF ENVIRONMENTAL PRESERVATION, ALTERNATIVE ENERGY, ENVIRONMENTAL SUSTAINABILITY AND HEALTHY LIVING (U.S. CLS. 100, 101 AND 107).

DAVID YONTEF, EXAMINING ATTORNEY

SN 85-442,379. THE CHRISTIAN BROTHERS OF J. K. MULLEN HIGH SCHOOL, INC., DENVER, CO. FILED 10-7-2011.

Mullen High School

THE MARK CONSISTS OF STANDARD CHARACTERS WITHOUT CLAIM TO ANY PARTICULAR FONT, STYLE, SIZE, OR COLOR.

NO CLAIM IS MADE TO THE EXCLUSIVE RIGHT TO USE "HIGH SCHOOL", APART FROM THE MARK AS SHOWN.

SEC. 2(F).

FOR EDUCATING AT SENIOR HIGH SCHOOLS (U.S. CLS. 100, 101 AND 107).

FIRST USE 0-0-1954; IN COMMERCE 0-0-1954.
LINDA E. BLOHM, EXAMINING ATTORNEY

CLASS 41—(Continued).

SN 85-442,383. THE CULTURED SEED, LLC, NORTH HILLS, CA. FILED 10-7-2011.

THE CULTURED SEED

THE MARK CONSISTS OF STANDARD CHARACTERS WITHOUT CLAIM TO ANY PARTICULAR FONT, STYLE, SIZE, OR COLOR.

FOR PROVIDING A WEBSITE FEATURING BLOGS FOR PARENTS IN THE FIELD OF CHILDREN'S ENTERTAINMENT, CULTURAL EVENTS, FOOD, ARTS, TRAVEL AND EDUCATION; ARRANGING, CONDUCTING, ORGANIZING AND HOSTING SOCIAL ENTERTAINMENT EVENTS FOR FAMILIES; ARRANGING, CONDUCTING, ORGANIZING AND HOSTING EDUCATIONAL EVENTS FOR FAMILIES, NAMELY, CULTURAL AND ARTS EVENTS (U.S. CLS. 100, 101 AND 107).

FIRST USE 2-14-2010; IN COMMERCE 2-14-2010.
TRICIA SONNEBORN, EXAMINING ATTORNEY

SN 85-442,423. THE CHRISTIAN BROTHERS OF J. K. MULLEN HIGH SCHOOL, INC., DENVER, CO. FILED 10-7-2011.

MULLEN

THE MARK CONSISTS OF THE WORD "MULLEN" IN A STYLIZED FONT WITH A STAR BETWEEN THE "L'S OF THE WORD.

FOR EDUCATING AT SENIOR HIGH SCHOOLS (U.S. CLS. 100, 101 AND 107).
FIRST USE 7-31-2011; IN COMMERCE 7-31-2011.
LINDA E. BLOHM, EXAMINING ATTORNEY

CLASS 41—(Continued).

SN 85-442,657. WEIDNER RESORT DEVELOPMENT, INC., LAS VEGAS, NV. FILED 10-7-2011.



THE MARK CONSISTS OF A RENDERING OF A GATE WITH CHINESE CHARACTERS TO THE RIGHT AND THE WORDS "XING GONG TRAVELING PALACE" BELOW THE RENDERING, WITH HORIZONTAL LINES ABOVE AND BELOW THE WORDING.

THE ENGLISH TRANSLATION OF "XING GONG" IN THE MARK IS TRAVELING PALACE.

THE NON-LATIN CHARACTERS IN THE MARK TRANSLITERATE TO "XING GONG" AND THIS MEANS "TRAVELING PALACE" IN ENGLISH.

FOR CASINOS; CASINO SERVICES, FEATURING A CASINO CUSTOMER LOYALTY PROGRAM THAT PROVIDES CASINO BENEFITS TO REWARD REPEAT CUSTOMERS; HEALTH CLUB, NAMELY, PROVIDING INSTRUCTION AND EQUIPMENT IN THE FIELD OF PHYSICAL EXERCISE; AMUSEMENT ARCADES; BEACH AND POOL CLUBS, NAMELY, PROVIDING FITNESS AND EXERCISE FACILITIES FEATURING POOLS AND BATHING AND SHOWERING FACILITIES; PROVISION OF SPORTS FACILITIES, SPORTS INSTRUCTION SERVICES, ARRANGING AND CONDUCTING ATHLETIC EVENTS AND ATHLETIC COMPETITIONS; ARRANGING OF SEMINARS, ART EXHIBITIONS; PHOTOGRAPHY SERVICES (U.S. CLS. 100, 101 AND 107).

ROBIN MITTLER, EXAMINING ATTORNEY

SN 85-442,668. SCRUBLAND FILMS, SANTA FE, NM. FILED 10-7-2011.

Scrubland Films

THE MARK CONSISTS OF STANDARD CHARACTERS WITHOUT CLAIM TO ANY PARTICULAR FONT, STYLE, SIZE, OR COLOR.

NO CLAIM IS MADE TO THE EXCLUSIVE RIGHT TO USE "FILMS", APART FROM THE MARK AS SHOWN.

FOR DOCUMENTARY FILM PRODUCTION AND EDITING SERVICES; VIDEO PRODUCTION CONSULTING SERVICES (U.S. CLS. 100, 101 AND 107).

FONG HSU, EXAMINING ATTORNEY

CLASS 41—(Continued).

SN 85-443,004. RYAN PUBLISHERS AND PUBLICATIONS MANAGEMENT CO., INC., DBA RYAN & CO., INC., WASHINGTON, DC. FILED 10-10-2011.

GOVLISH

THE MARK CONSISTS OF STANDARD CHARACTERS WITHOUT CLAIM TO ANY PARTICULAR FONT, STYLE, SIZE, OR COLOR.

FOR PROVIDING AN INTERNET WEBSITE PORTAL IN THE NATURE OF AN ONLINE REFERENCE LIBRARY FEATURING AN ONLINE NON-DOWNLOADABLE DATABASE IN THE FIELDS OF FEDERAL AND STATE GOVERNMENT ACRONYMS, ABBREVIATIONS, AND TERMS (U.S. CLS. 100, 101 AND 107).

FIRST USE 10-4-2011; IN COMMERCE 10-4-2011.
JENNIFER WILLISTON, EXAMINING ATTORNEY

SN 85-443,014. MOTTO CITIZENS, LLC, DENMARK, ME. FILED 10-10-2011.

BROADCAST WISDOM

THE MARK CONSISTS OF STANDARD CHARACTERS WITHOUT CLAIM TO ANY PARTICULAR FONT, STYLE, SIZE, OR COLOR.

NO CLAIM IS MADE TO THE EXCLUSIVE RIGHT TO USE "BROADCAST", APART FROM THE MARK AS SHOWN.

FOR EDUCATION SERVICES, NAMELY, PROVIDING CLASSES, SEMINARS, WORKSHOPS AND LECTURES VIA PODCASTS AND STREAMING AUDIO AND VIDEO IN THE FIELD OF RELIGION, PHILOSOPHY, CONTEMPLATION AND ENLIGHTENMENT (U.S. CLS. 100, 101 AND 107).

TASHIA BUNCH, EXAMINING ATTORNEY

SN 85-443,119. SCHMIDT, MARY SUSAN, DBA SUSAN SCHMIDT, BEAUFORT, NC. FILED 10-10-2011.

Polish to Publish

THE MARK CONSISTS OF STANDARD CHARACTERS WITHOUT CLAIM TO ANY PARTICULAR FONT, STYLE, SIZE, OR COLOR.

FOR WRITTEN TEXT EDITING (U.S. CLS. 100, 101 AND 107).

FIRST USE 6-1-2009; IN COMMERCE 6-1-2009.
GEOFFREY FOSDICK, EXAMINING ATTORNEY

CLASS 41—(Continued).

SN 85-443,392. SUNCOAST DENTAL, INC., CLEARWATER, FL. FILED 10-10-2011.

NIRISAB

THE MARK CONSISTS OF STANDARD CHARACTERS WITHOUT CLAIM TO ANY PARTICULAR FONT, STYLE, SIZE, OR COLOR.

FOR EDUCATIONAL SEMINARS, CLASSES, PRESENTATIONS, WORKSHOPS, TRAINING PROGRAMS, LECTURES AND ONE-ON-ONE MENTORING IN THE FIELDS OF IMPLANT DENTISTRY, ORAL REHABILITATION AND BONE AUGMENTATION TECHNIQUES (U.S. CLS. 100, 101 AND 107).

JENNIFER VASQUEZ, EXAMINING ATTORNEY

SN 85-443,549. MICHAEL SUMNER, GASTONIA, NC. FILED 10-10-2011.



NO CLAIM IS MADE TO THE EXCLUSIVE RIGHT TO USE "CHAMPIONS CLASSIC", APART FROM THE MARK AS SHOWN.

THE COLOR(S) RED, WHITE, ROYAL BLUE, AND LIGHT BLUE IS/ARE CLAIMED AS A FEATURE OF THE MARK.

THE MARK CONSISTS OF THE WORD "CHAMPIONS" IN RED, OUTLINED IN ROYAL BLUE, WITH A RED RIBBON UNDERNEATH IT AND THE WORD "CLASSIC" IN WHITE OUTLINED IN ROYAL BLUE WITHIN THE RIBBON. IN THE BACKGROUND IS A LIGHT BLUE CIRCLE WITH A RED BASKETBALL AT THE BOTTOM THE CIRCLE. THE LIGHT BLUE CIRCLE HAS A WHITE OUTLINE, THEN THICKER ROYAL BLUE OUTLINE, THEN ANOTHER WHITE OUTLINE AND ANOTHER ROYAL BLUE OUTLINE.

FOR ENTERTAINMENT IN THE NATURE OF BASKETBALL GAMES (U.S. CLS. 100, 101 AND 107).

FIRST USE 10-1-2011; IN COMMERCE 10-1-2011.
BRIAN NEVILLE, EXAMINING ATTORNEY

CLASS 41—(Continued).

SN 85-443,555. NEW CHAPTER ENTERTAINMENT LLC, CHICAGO, IL. FILED 10-10-2011.



NO CLAIM IS MADE TO THE EXCLUSIVE RIGHT TO USE "ENTERTAINMENT LLC", APART FROM THE MARK AS SHOWN.

THE COLOR(S) BLUE, YELLOW, WHITE, BLACK, AND GRAY IS/ARE CLAIMED AS A FEATURE OF THE MARK.

THE MARK CONSISTS OF THE BLUE STYLIZED WORDS "NEW CHAPTER ENTERTAINMENT LLC" ABOVE A PICTURE OF A YELLOW AND WHITE TELEVISION SET WITH A BLACK AND GRAY BLANK SCREEN WITH ITS GRAY ANTENNA EXTENDING UPWARD THROUGH THE WORD "CHAPTER".

FOR ENTERTAINMENT MEDIA PRODUCTION SERVICES FOR MOTION PICTURES, TELEVISION AND INTERNET (U.S. CLS. 100, 101 AND 107).

KATHLEEN LORENZO, EXAMINING ATTORNEY

CLASS 41—(Continued).

SN 85-444,177. VARSITY VOCALS, LLC, CHICAGO, IL. FILED 10-11-2011.

ICCA

THE MARK CONSISTS OF STANDARD CHARACTERS WITHOUT CLAIM TO ANY PARTICULAR FONT, STYLE, SIZE, OR COLOR.

FOR EDUCATIONAL SERVICES IN THE FIELD OF MUSIC, NAMELY, ORGANIZING AND CONDUCTING MUSIC COMPETITIONS AND PROVIDING INSTRUCTION IN THE FIELD OF MUSIC AND MUSIC PERFORMANCE; PRODUCTION OF LIVE ENTERTAINMENT EVENTS, NAMELY, LIVE MUSICAL CONCERTS; ENTERTAINMENT SERVICES, NAMELY, ORGANIZING AND CONDUCTING LIVE MUSICAL EVENTS (U.S. CLS. 100, 101 AND 107).

FIRST USE 0-0-2000; IN COMMERCE 0-0-2000.

MELISSA VALLILLO, EXAMINING ATTORNEY

SN 85-444,313. LANDAU, MARIANGELA PINO, DBA THE CENTER FOR TRUE NORTH,LLC, SPRINGDALE, UT. FILED 10-11-2011.

A.L.I.V.E. Workshops

THE MARK CONSISTS OF STANDARD CHARACTERS WITHOUT CLAIM TO ANY PARTICULAR FONT, STYLE, SIZE, OR COLOR.

NO CLAIM IS MADE TO THE EXCLUSIVE RIGHT TO USE "WORKSHOPS", APART FROM THE MARK AS SHOWN.

FOR EDUCATION SERVICES, NAMELY, PROVIDING LIVE AND ON-LINE CLASSES, SEMINARS, WORKSHOPS AND PRESENTATIONS IN THE FIELD OF SPIRITUALITY, SELF IMPROVEMENT, PHILOSOPHY (U.S. CLS. 100, 101 AND 107).

FIRST USE 9-24-2011; IN COMMERCE 9-24-2011.

MICHAEL GAFFAR, EXAMINING ATTORNEY

SN 85-444,064. PHASE 3 EVENTS LLC, SEATTLE, WA. FILED 10-11-2011.

white out electronic music festival

THE MARK CONSISTS OF STANDARD CHARACTERS WITHOUT CLAIM TO ANY PARTICULAR FONT, STYLE, SIZE, OR COLOR.

NO CLAIM IS MADE TO THE EXCLUSIVE RIGHT TO USE "ELECTRONIC MUSIC FESTIVAL", APART FROM THE MARK AS SHOWN.

FOR ENTERTAINMENT IN THE NATURE OF A LIVE MUSIC FESTIVAL (U.S. CLS. 100, 101 AND 107).

FIRST USE 11-1-2003; IN COMMERCE 11-1-2003.

KIMBERLY PERRY, EXAMINING ATTORNEY

SN 85-444,442. MORALES, MARK WARREN, TIBURON, CA. FILED 10-11-2011.

prime:game

THE MARK CONSISTS OF STANDARD CHARACTERS WITHOUT CLAIM TO ANY PARTICULAR FONT, STYLE, SIZE, OR COLOR.

FOR COMPUTER EDUCATION TRAINING SERVICES; EDUCATION SERVICES, NAMELY, PROVIDING ON-LINE EDUCATIONAL COMPUTER GAMES FOR USE IN DEVELOPING KNOWLEDGE OF CORE CONCEPTS IN THE FIELDS OF SCIENCE, MATHEMATICS, ART, AND GRAPHIC DESIGN (U.S. CLS. 100, 101 AND 107).

MICHAEL GAFFAR, EXAMINING ATTORNEY

CLASS 41—(Continued).

SN 85-444,520. SAFARI CLUB INTERNATIONAL, LOS ANGELES AND ORANGE COUNTY CHAPTERS, MISSION VIEJO, CA. FILED 10-11-2011.

YOUTHSAFARID AY

THE MARK CONSISTS OF STANDARD CHARACTERS WITHOUT CLAIM TO ANY PARTICULAR FONT, STYLE, SIZE, OR COLOR.

FOR EDUCATION SERVICES, NAMELY, PROVIDING PARTICIPATORY EXHIBITIONS IN THE FIELD OF OUTDOOR ACTIVITIES, NAMELY, ARCHERY, BB GUNS, KAYAKING, FISHING, FALCONRY, SHOOTING, LASER SHOT, MAKING GAME CALLS, PAINTING DUCK DECOYS, PAINTBALL GAMES, IDENTIFYING ANIMALS, AND HORSEBACK RIDING (U.S. CLS. 100, 101 AND 107).

FIRST USE 7-31-1999; IN COMMERCE 7-31-1999.
LINDA LAVACHE, EXAMINING ATTORNEY

SN 85-444,542. URBAN STUDENTS EMPOWERED FOUNDATION, CHICAGO, IL. FILED 10-11-2011.

OneGoal

THE MARK CONSISTS OF STANDARD CHARACTERS WITHOUT CLAIM TO ANY PARTICULAR FONT, STYLE, SIZE, OR COLOR.

FOR CHARITABLE SERVICES, NAMELY, PROVIDING COLLEGE PREPARATORY CLASSES AND WORKSHOPS TO LOW INCOME STUDENTS (U.S. CLS. 100, 101 AND 107).

WON TEAK OH, EXAMINING ATTORNEY

SN 85-444,710. LINK TRANSLATIONS INC., NEW YORK, NY. FILED 10-11-2011.



NO CLAIM IS MADE TO THE EXCLUSIVE RIGHT TO USE "TRANSLATIONS", APART FROM THE MARK AS SHOWN.

THE MARK CONSISTS OF THE WORD "LINK" BEING PARTIALLY CIRCLED BY 2 TWIRLING ARROW DESIGNS ALL WITHIN A SHADED RECTANGLE. BELOW THE RECTANGLE IS THE WORD "TRANSLATIONS".

FOR LANGUAGE TRANSLATION (U.S. CLS. 100, 101 AND 107).

FIRST USE 0-0-2008; IN COMMERCE 0-0-2008.
JENNIFER VASQUEZ, EXAMINING ATTORNEY

CLASS 41—(Continued).

SN 85-445,024. DOLCE DIVA MUSIC, LLC, NEW YORK, NY. FILED 10-12-2011.

DOLCE DIVA MUSIC

THE MARK CONSISTS OF STANDARD CHARACTERS WITHOUT CLAIM TO ANY PARTICULAR FONT, STYLE, SIZE, OR COLOR.

NO CLAIM IS MADE TO THE EXCLUSIVE RIGHT TO USE "MUSIC", APART FROM THE MARK AS SHOWN.

THE ENGLISH TRANSLATION OF "DOLCE DIVA" IN THE MARK IS "SWEET DIVA".

FOR RECORD PRODUCTION; RECORD MASTER PRODUCTION; MUSIC PRODUCTION; AUDIO RECORDING AND PRODUCTION; VIDEOTAPE PRODUCTION; ENTERTAINMENT SERVICES, NAMELY, PRODUCING AND DISTRIBUTING MUSICAL AUDIO AND VIDEO RECORDINGS; ENTERTAINMENT IN THE NATURE OF A LIVE MUSICAL ARTIST, MUSICAL BAND AND MUSICAL GROUP; ENTERTAINMENT IN THE NATURE OF LIVE PERFORMANCES BY A MUSICAL ARTIST, MUSICAL BAND AND MUSICAL GROUP; ENTERTAINMENT IN THE NATURE OF VISUAL AND AUDIO PERFORMANCES BY A MUSICAL ARTIST, MUSICAL BAND AND MUSICAL GROUP; ENTERTAINMENT, NAMELY, LIVE MUSIC CONCERTS; ENTERTAINMENT, NAMELY, PERSONAL APPEARANCES BY A MUSICAL ARTIST, MUSICAL BAND AND MUSICAL GROUP; ENTERTAINMENT SERVICES, NAMELY, PROVIDING A WEB SITE FEATURING NON-DOWNLOADABLE MUSICAL PERFORMANCES, MUSICAL VIDEOS, RELATED FILM CLIPS, PHOTOGRAPHS, AND OTHER MULTIMEDIA MATERIALS IN THE FIELD OF MUSIC; ENTERTAINMENT SERVICES, NAMELY, PROVIDING NON-DOWNLOADABLE PRERECORDED MUSIC, INFORMATION IN THE FIELD OF MUSIC, COMMENTARY AND ARTICLES ABOUT MUSIC, ALL ONLINE VIA A GLOBAL COMPUTER NETWORK (U.S. CLS. 100, 101 AND 107).

FIRST USE 7-18-2002; IN COMMERCE 2-27-2004.
LAURIE KAUFMAN, EXAMINING ATTORNEY

SN 85-445,192. SCHOBBER, ANTHONY, PLANO, TX. FILED 10-12-2011.

Coach Calorie

THE MARK CONSISTS OF STANDARD CHARACTERS WITHOUT CLAIM TO ANY PARTICULAR FONT, STYLE, SIZE, OR COLOR.

FOR PROVIDING A WEBSITE FEATURING SERVICES, INFORMATION AND ADVICE IN THE FIELDS OF DIET, WEIGHT LOSS, DIET PLANNING AND LIFESTYLE WELLNESS (U.S. CLS. 100, 101 AND 107).

DAVID I, EXAMINING ATTORNEY

CLASS 41—(Continued).

SN 85-445,235. THE GRACE TRUST, INC., WINONA LAKE, IN. FILED 10-12-2011.

ENCOMPASS WORLD PARTNERS

THE MARK CONSISTS OF STANDARD CHARACTERS WITHOUT CLAIM TO ANY PARTICULAR FONT, STYLE, SIZE, OR COLOR.

FOR EDUCATIONAL SERVICES, NAMELY, PROVIDING INSTRUCTION AND TRAINING PROGRAMS IN THE FIELD OF MISSIONARY WORK AND IN CHRISTIANITY; RELIGIOUS INSTRUCTION SERVICES (U.S. CLS. 100, 101 AND 107).

LEIGH CAROLINE CASE, EXAMINING ATTORNEY

SN 85-445,449. NEW YORK MEDIA LLC, NEW YORK, NY. FILED 10-12-2011.

VULTURE

THE MARK CONSISTS OF STANDARD CHARACTERS WITHOUT CLAIM TO ANY PARTICULAR FONT, STYLE, SIZE, OR COLOR.

OWNER OF U.S. REG. NO. 3,368,526.

FOR ENTERTAINMENT SERVICES, NAMELY, PROVIDING A WEB SITE FEATURING INFORMATION, NEWS, COMMENTARY, REVIEWS AND INTERVIEWS ON THE SUBJECTS OF MOTION PICTURES, TELEVISION PROGRAMS, MUSIC, BOOKS, ART, THEATER PRODUCTIONS, POPULAR CULTURE AND THE ENTERTAINMENT INDUSTRY (U.S. CLS. 100, 101 AND 107).

FIRST USE 2-1-2010; IN COMMERCE 2-1-2010.
CIMMERIAN COLEMAN, EXAMINING ATTORNEY

SN 85-445,537. CABLE NEWS NETWORK, INC., ATLANTA, GA. FILED 10-12-2011.

SCHOOLS OF THOUGHT

THE MARK CONSISTS OF STANDARD CHARACTERS WITHOUT CLAIM TO ANY PARTICULAR FONT, STYLE, SIZE, OR COLOR.

FOR ON-LINE JOURNALS, NAMELY, BLOGS FEATURING NEWS, ENTERTAINMENT, CURRENT EVENTS AND POLITICS (U.S. CLS. 100, 101 AND 107).

LINDA M. KING, EXAMINING ATTORNEY

CLASS 41—(Continued).

SN 85-445,662. MARS HILL CHURCH, SEATTLE, WA. FILED 10-12-2011.

Re:Train

THE MARK CONSISTS OF STANDARD CHARACTERS WITHOUT CLAIM TO ANY PARTICULAR FONT, STYLE, SIZE, OR COLOR.

FOR EDUCATION SERVICES, NAMELY, LECTURES, COURSES AND WORKSHOPS IN THE FIELD OF THEOLOGY AND MINISTRY; EDUCATION SERVICES IN THE NATURE OF COURSES AT THE UNIVERSITY LEVEL (U.S. CLS. 100, 101 AND 107).

FIRST USE 4-0-2009; IN COMMERCE 4-0-2009.
RONALD MCMORROW, EXAMINING ATTORNEY

SN 85-445,694. NEW ENGLAND MAIL ORDER ASSOCIATION, DBA NEMOA, SCARBOROUGH, ME. FILED 10-12-2011.

DIRECTXCHANGE

THE MARK CONSISTS OF STANDARD CHARACTERS WITHOUT CLAIM TO ANY PARTICULAR FONT, STYLE, SIZE, OR COLOR.

FOR CONDUCTING WORKSHOPS AND SEMINARS IN MATTERS RELATING TO THE FIELD OF DIRECT MARKETING (U.S. CLS. 100, 101 AND 107).

FIRST USE 1-15-2011; IN COMMERCE 1-15-2011.
RONALD MCMORROW, EXAMINING ATTORNEY

SN 85-445,778. SMITH, LOWELL V., ST.HELENA, CA. FILED 10-12-2011.

The Napa Valley Wine Wave
a joyful sequential wine toast

THE MARK CONSISTS OF STANDARD CHARACTERS WITHOUT CLAIM TO ANY PARTICULAR FONT, STYLE, SIZE, OR COLOR.

NO CLAIM IS MADE TO THE EXCLUSIVE RIGHT TO USE "NAPA VALLEY WINE", APART FROM THE MARK AS SHOWN.

FOR ORGANIZING COMMUNITY FESTIVALS FEATURING A VARIETY OF ACTIVITIES, NAMELY, LIVE MUSIC, ART AND FOOD DISPLAYS, WINE TASTING, TOASTING AND PARTICIPATORY GAMES (U.S. CLS. 100, 101 AND 107).

JAMES LOVELACE, EXAMINING ATTORNEY

CLASS 41—(Continued).

SN 85-445,843. N-M VENTURES, LLC, LAS VEGAS, NV.
FILED 10-12-2011.

GBDC

THE MARK CONSISTS OF STANDARD CHARACTERS WITHOUT CLAIM TO ANY PARTICULAR FONT, STYLE, SIZE, OR COLOR.

FOR ARRANGING FOR TICKET RESERVATIONS FOR SHOWS AND OTHER ENTERTAINMENT EVENTS; DISC JOCKEY SERVICES; ENTERTAINMENT IN THE NATURE OF LIVE PERFORMANCES FEATURING MUSICIANS, DANCERS, ACTORS, AND ACROBATS; NIGHT CLUBS; PROVIDING FACILITIES FOR PRODUCING VIDEO, CINEMA AND PHOTOGRAPHY PRODUCTIONS; PROVIDING FACILITIES FOR RECREATION ACTIVITIES; SPECIAL EVENT PLANNING FOR SOCIAL ENTERTAINMENT PURPOSES (U.S. CLS. 100, 101 AND 107).

FIRST USE 10-22-2011; IN COMMERCE 10-22-2011.
BRENDAN MCCAULEY, EXAMINING ATTORNEY

SN 85-445,871. GOTFREDSON, MICHAEL B., LA JOLLA, CA.
FILED 10-12-2011.

1ST THURSDAY ADVENTURE RUN

THE MARK CONSISTS OF STANDARD CHARACTERS WITHOUT CLAIM TO ANY PARTICULAR FONT, STYLE, SIZE, OR COLOR.

NO CLAIM IS MADE TO THE EXCLUSIVE RIGHT TO USE "1ST THURSDAY" AND "RUN", APART FROM THE MARK AS SHOWN.

FOR ORGANIZING, ARRANGING, AND CONDUCTING RUNNING EVENTS (U.S. CLS. 100, 101 AND 107).

FIRST USE 2-1-2011; IN COMMERCE 2-1-2011.
LUCY ARANT, EXAMINING ATTORNEY

CLASS 41—(Continued).

SN 85-445,906. NBA DEVELOPMENT LEAGUE, LLC., SECA-CUS, NJ. FILED 10-12-2011.



NO CLAIM IS MADE TO THE EXCLUSIVE RIGHT TO USE "CANTON", APART FROM THE MARK AS SHOWN.

THE MARK CONSISTS OF A MAN HOLDING A SWORD. THE WORDS CANTON CHARGE APPEARING UNDER THE SWORD.

FOR ENTERTAINMENT AND EDUCATIONAL SERVICES IN THE NATURE OF ONGOING TELEVISION AND RADIO PROGRAMS IN THE FIELD OF BASKETBALL AND RENDERING LIVE BASKETBALL GAMES AND BASKETBALL EXHIBITIONS; THE PRODUCTION AND DISTRIBUTION OF RADIO AND TELEVISION SHOWS FEATURING BASKETBALL GAMES, BASKETBALL EVENTS AND PROGRAMS IN THE FIELD OF BASKETBALL; CONDUCTING AND ARRANGING BASKETBALL CLINICS AND CAMPS, COACHES CLINICS AND CAMPS, DANCE TEAM CLINICS AND CAMPS AND BASKETBALL GAMES; ENTERTAINMENT SERVICES IN THE NATURE OF PERSONAL APPEARANCES BY A COSTUMED MASCOT OR DANCE TEAM AT BASKETBALL GAMES AND EXHIBITIONS, CLINICS, CAMPS, PROMOTIONS, AND OTHER BASKETBALL-RELATED EVENTS, SPECIAL EVENTS AND PARTIES; FAN CLUB SERVICES; ENTERTAINMENT SERVICES, NAMELY PROVIDING A WEBSITE FEATURING MULTIMEDIA MATERIAL IN THE NATURE OF TELEVISION HIGHLIGHTS, INTERACTIVE TELEVISION HIGHLIGHTS, VIDEO RECORDINGS, VIDEO STREAM RECORDINGS, INTERACTIVE VIDEO HIGHLIGHT SELECTIONS, RADIO PROGRAMS, RADIO HIGHLIGHTS, AND AUDIO RECORDINGS IN THE FIELD OF BASKETBALL; PROVIDING NEWS AND INFORMATION IN THE NATURE OF STATISTICS AND TRIVIA IN THE FIELD OF BASKETBALL; ON-LINE NON-DOWNLOADABLE GAMES, NAMELY, COMPUTER GAMES, VIDEO GAMES, INTERACTIVE VIDEO GAMES, ACTION SKILL GAMES, ARCADE GAMES, ADULTS' AND CHILDREN'S PARTY GAMES, BOARD GAMES, PUZZLES, AND TRIVIA GAMES; ELECTRONIC PUBLISHING SERVICES, NAMELY, PUBLICATION OF MAGAZINES, GUIDES, NEWSLETTERS, COLORING BOOKS, AND GAME SCHEDULES OF OTHERS ON-LINE THROUGH THE INTERNET, ALL IN THE FIELD OF BASKETBALL; PROVIDING AN ONLINE COMPUTER DATABASE IN THE FIELD OF BASKETBALL (U.S. CLS. 100, 101 AND 107).

ARETHA SOMERVILLE, EXAMINING ATTORNEY

CLASS 41—(Continued).

SN 85-445,909. N-M VENTURES, LLC, LAS VEGAS, NV.
FILED 10-12-2011.



FOR ARRANGING FOR TICKET RESERVATIONS FOR SHOWS AND OTHER ENTERTAINMENT EVENTS; DISC JOCKEY SERVICES; ENTERTAINMENT IN THE NATURE OF LIVE PERFORMANCES FEATURING MUSICIANS, DANCERS, ACTORS AND ACROBATS; NIGHT CLUBS; PROVIDING FACILITIES FOR PRODUCING VIDEO, CINEMA AND PHOTOGRAPHY PRODUCTIONS; PROVIDING FACILITIES FOR RECREATION ACTIVITIES; SPECIAL EVENT PLANNING FOR SOCIAL ENTERTAINMENT PURPOSES (U.S. CLS. 100, 101 AND 107).

FIRST USE 10-22-2011; IN COMMERCE 10-22-2011.
BRENDAN MCCAULEY, EXAMINING ATTORNEY

SN 85-445,912. GOTFREDSON, MICHAEL B., LA JOLLA, CA.
FILED 10-12-2011.

2ND THURSDAY ADVENTURE RUN

THE MARK CONSISTS OF STANDARD CHARACTERS WITHOUT CLAIM TO ANY PARTICULAR FONT, STYLE, SIZE, OR COLOR.

NO CLAIM IS MADE TO THE EXCLUSIVE RIGHT TO USE "2ND THURSDAY" AND "RUN", APART FROM THE MARK AS SHOWN.

FOR ORGANIZING, ARRANGING, AND CONDUCTING RUNNING EVENTS (U.S. CLS. 100, 101 AND 107).

FIRST USE 2-1-2011; IN COMMERCE 2-1-2011.
LUCY ARANT, EXAMINING ATTORNEY

SN 85-446,184. INVENE0, INC, SAN FRANCISCO, CA.
FILED 10-13-2011.

ICTWORKS

THE MARK CONSISTS OF STANDARD CHARACTERS WITHOUT CLAIM TO ANY PARTICULAR FONT, STYLE, SIZE, OR COLOR.

FOR ON-LINE JOURNALS, NAMELY, BLOGS FEATURING RESOURCES AND INFORMATION FOR SHARING AND EXPANDING KNOWLEDGE ON APPROPRIATE INFORMATION AND COMMUNICATION TECHNOLOGIES (ICT) AND THE IMPLEMENTATION PROCESSES THAT CAN MAKE THEM SUSTAINABLE IN RURAL AND UNDERSERVED COMMUNITIES ACROSS THE DEVELOPING WORLD (U.S. CLS. 100, 101 AND 107).

FIRST USE 5-16-2009; IN COMMERCE 7-15-2009.
DEBORAH LOBO, EXAMINING ATTORNEY

CLASS 41—(Continued).

SN 85-446,229. EXECUQUEST CORPORATION, BALTIMORE, MD. FILED 10-13-2011.

SEVEN HABITS OF SUCCESSFUL SOURCERS

THE MARK CONSISTS OF STANDARD CHARACTERS WITHOUT CLAIM TO ANY PARTICULAR FONT, STYLE, SIZE, OR COLOR.

FOR WORKSHOPS PROVIDING TRAINING IN PERSONNEL RECRUITMENT RESEARCH AND STRATEGY (U.S. CLS. 100, 101 AND 107).

JAMES A. RAUEN, EXAMINING ATTORNEY

SN 85-446,277. MTS LOGISTICS, INC., NEW YORK, NY.
FILED 10-13-2011.



THE MARK CONSISTS OF THE WORDS "MORE THAN SHIPPING" WITH THE FIRST LETTERS OF EACH WORD APPEARING IN A BOX.

FOR ON-LINE JOURNALS, NAMELY, BLOGS FEATURING INFORMATION ABOUT GLOBAL TRADE, LOGISTICS AND SHIPPING (U.S. CLS. 100, 101 AND 107).

FIRST USE 7-19-2011; IN COMMERCE 7-19-2011.
MAYUR VAGHANI, EXAMINING ATTORNEY

SN 85-446,301. JOE BUFF, INC., MILAN, NY. FILED 10-13-2011.

TIDAL RIP

THE MARK CONSISTS OF STANDARD CHARACTERS WITHOUT CLAIM TO ANY PARTICULAR FONT, STYLE, SIZE, OR COLOR.

FOR ENTERTAINMENT SERVICES IN THE FIELD OF FILM AND TELEVISION, NAMELY, THE PRODUCTION AND DISTRIBUTION OF MOTION PICTURE FILMS, ANIMATED MOVIES, TELEVISION PROGRAMS AND PRODUCTION OF COMPUTER GENERATED IMAGES FOR MOTION PICTURE FILMS, ANIMATED MOVIES, VIDEOS, ANIMATED VIDEOS, TELEVISION PROGRAMS; PRODUCTION OF VIDEOS AND ANIMATED VIDEOS; ANIMATION PRODUCTION SERVICES; PROVIDING TELEVISION AND MOTION PICTURE AUDIO AND VISUAL SPECIAL EFFECTS ANIMATION SERVICES FOR FILM, VIDEO AND TELEVISION; PROVIDING NEWS IN THE FIELD OF ENTERTAINMENT; MULTIMEDIA ENTERTAINMENT SERVICES IN THE NATURE OF PRE-PRODUCTION CONTENT PREPARATION AND POST-PRODUCTION SERVICES IN THE FIELDS OF MOTION PICTURES, VIDEOS, ANIMATION, AND TELEVISION PROGRAMS; ENTERTAINMENT SERVICES PROVIDED ON-LINE BY MEANS OF GLO-

CLASS 41—(Continued).

BAL AND LOCAL AREA NETWORKS, NAMELY, PROVIDING ENTERTAINMENT INFORMATION REGARDING TELEVISION AND MOTION PICTURE FILMS AND INTERACTIVE COMPUTER GAME SOFTWARE, INTERACTIVE VIDEO GAME SOFTWARE AND INTERACTIVE COMPUTER GAMES AND INTERACTIVE VIDEO GAMES, ALL ON-LINE BY MEANS OF GLOBAL AND LOCAL AREA NETWORKS; PROVIDING NEWS IN THE FIELD OF ENTERTAINMENT RELATING TO INTERACTIVE COMPUTER GAME SOFTWARE AND INTERACTIVE VIDEO GAME SOFTWARE OVER AN ELECTRONIC NETWORK; EDUCATIONAL AND ENTERTAINMENT SERVICES, NAMELY, A CONTINUING PROGRAM ABOUT NEWS RELATING TO ADVENTURE-BASED ENTERTAINMENT ACCESSIBLE BY COMPUTER NETWORKS; FAN CLUB SERVICES; PROVIDING AN ON-LINE INTERACTIVE COMPUTER GAME OVER AN ELECTRONIC NETWORK THAT MAY BE ACCESSED NETWORK-WIDE BY NETWORK USERS; PROVIDING ONLINE COMPUTER GAMES (U.S. CLS. 100, 101 AND 107).

JAMES GRIFFIN, EXAMINING ATTORNEY

CLASS 41—(Continued).

SN 85-446,375. THE HOTCAKES LLC, NEW YORK, NY. FILED 10-13-2011.

THE HOTCAKES

THE MARK CONSISTS OF STANDARD CHARACTERS WITHOUT CLAIM TO ANY PARTICULAR FONT, STYLE, SIZE, OR COLOR.

OWNER OF U.S. REG. NO. 4,038,065.

FOR ENTERTAINMENT, NAMELY, LIVE PERFORMANCES BY A MUSICAL BAND (U.S. CLS. 100, 101 AND 107).

FIRST USE 8-30-2007; IN COMMERCE 8-30-2007.
SHANNON TWOHIG, EXAMINING ATTORNEY

SN 85-446,343. PAN AMERICAN LANGUAGE SERVICES, INC. DBA PALS INTERNATIONAL, TROY, MI. FILED 10-13-2011.



NO CLAIM IS MADE TO THE EXCLUSIVE RIGHT TO USE "INTERNATIONAL" AND THE DESIGN OF THE GLOBE, APART FROM THE MARK AS SHOWN.

THE COLOR(S) WHITE, BLACK AND GOLD IS/ARE CLAIMED AS A FEATURE OF THE MARK.

THE MARK CONSISTS OF THE WORDING "PALS INTERNATIONAL" IN WHITE ABOVE A GOLD AND BLACK GLOBE AGAINST A GOLD BACKGROUND.

FOR INTERACTIVE ON-LINE TRAINING SERVICES IN THE FIELD OF FOREIGN LANGUAGE INSTRUCTION; LANGUAGE INSTRUCTION; LANGUAGE INTERPRETATION SERVICES PROVIDED BY TELEPHONE; LANGUAGE INTERPRETER SERVICES; LANGUAGE INTERPRETING; LANGUAGE TRANSLATION; PROVIDING VOICE OVERS FOR TAPES, RECORDS AND OTHER RECORDED MEDIA FOR ENTERTAINMENT AND EDUCATION PURPOSES; TRANSLATION SERVICES (U.S. CLS. 100, 101 AND 107).

FIRST USE 0-0-1997; IN COMMERCE 0-0-1997.
SHANNON TWOHIG, EXAMINING ATTORNEY

SN 85-446,390. FURANO, DAVID, EL SEGUNDO, CA. FILED 10-13-2011.

Rocktoberfest

THE MARK CONSISTS OF STANDARD CHARACTERS WITHOUT CLAIM TO ANY PARTICULAR FONT, STYLE, SIZE, OR COLOR.

FOR CONDUCTING ENTERTAINMENT EXHIBITIONS IN THE NATURE OF BEER FESTIVALS (U.S. CLS. 100, 101 AND 107).

FIRST USE 8-8-2010; IN COMMERCE 8-8-2010.

GIANCARLO CASTRO, EXAMINING ATTORNEY

SN 85-446,408. NORTH AMERICAN SEMINARS, INC. FRANKLIN, TN. FILED 10-13-2011.

elomotus

THE MARK CONSISTS OF STANDARD CHARACTERS WITHOUT CLAIM TO ANY PARTICULAR FONT, STYLE, SIZE, OR COLOR.

FOR MEDICAL TRAINING AND TEACHING (U.S. CLS. 100, 101 AND 107).

FIRST USE 9-1-2011; IN COMMERCE 9-1-2011.

ANNE FARRELL, EXAMINING ATTORNEY

CLASS 41—(Continued).

SN 85-446,456. CHAPMAN, ROBERT L., NEW YORK, NY. FILED 10-13-2011.

Black Stars of the Great White Way

THE MARK CONSISTS OF STANDARD CHARACTERS WITHOUT CLAIM TO ANY PARTICULAR FONT, STYLE, SIZE, OR COLOR.

FOR ENTERTAINMENT IN THE NATURE OF VISUAL AND AUDIO PERFORMANCES, AND MUSICAL, VARIETY, NEWS AND COMEDY SHOWS (U.S. CLS. 100, 101 AND 107).

LINDA E. BLOHM, EXAMINING ATTORNEY

SN 85-446,480. BERG, MICHELLE, VENICE, CA. FILED 10-13-2011.

CREATE:FIXATE

THE MARK CONSISTS OF STANDARD CHARACTERS WITHOUT CLAIM TO ANY PARTICULAR FONT, STYLE, SIZE, OR COLOR.

FOR ART EXHIBITION SERVICES; ORGANIZATION OF EXHIBITIONS FOR CULTURAL OR EDUCATIONAL PURPOSES; ORGANIZING CULTURAL AND ARTS EVENTS (U.S. CLS. 100, 101 AND 107).

FIRST USE 4-23-1996; IN COMMERCE 11-1-2001.
KATHERINE CHANG, EXAMINING ATTORNEY

SN 85-446,484. TREVOR BAYNE INC., CORNELIUS, NC. FILED 10-13-2011.



THE MARK CONSISTS OF A STYLIZED "B" WITH A CROSS WITH A CROWN OF THORNS AT THE TOP.

FOR ENTERTAINMENT SERVICES, NAMELY, PARTICIPATION IN PROFESSIONAL AUTO RACES (U.S. CLS. 100, 101 AND 107).

FIRST USE 2-28-2011; IN COMMERCE 2-28-2011.
PATRICIA EVANKO, EXAMINING ATTORNEY

CLASS 41—(Continued).

SN 85-446,517. APEX INDUSTRIAL TECHNOLOGIES LLC, MASON, OH. FILED 10-13-2011.



NO CLAIM IS MADE TO THE EXCLUSIVE RIGHT TO USE "TECHNOLOGY", APART FROM THE MARK AS SHOWN.

THE MARK CONSISTS OF THE WORDS "APEX CONNECT N' GO TECHNOLOGY" IN A STYLIZED FORM, WITH THE WORD "APEX" ABOVE THE WORDS "CONNECT N' GO" WHICH IS ABOVE THE WORD "TECHNOLOGY". THERE ARE 4 LINES TO THE LEFT AND RIGHT OF THE WORD "APEX" AND A STYLIZED POWER CORD IN AN ELLIPTICAL SHAPE SURROUNDING ALL OF THE WORDS.

FOR COMPUTER SERVICES, NAMELY, PROVIDING A WEB-BASED SYSTEM AND ONLINE PORTAL FEATURING ON-LINE NON-DOWNLOADABLE SOFTWARE FOR USE IN TRACKING, PROCESSING AND PROVIDING USER ACCESS TO DATA RELATING TO DISPENSING, ACCESS AND USAGE OF HARDWARE, PARTS, SUPPLIES, COMPONENTS AND THE LIKE, AND FOR USE IN SUPPLY CHAIN MANAGEMENT, INVENTORY CONTROL, ACCESS CONTROL, DEMAND MANAGEMENT AND PROCESS CONTROL (U.S. CLS. 100, 101 AND 107).

FIRST USE 3-15-2008; IN COMMERCE 3-15-2008.
VIVIAN MICZNIK FIRST, EXAMINING ATTORNEY

SN 85-446,522. APEX INDUSTRIAL TECHNOLOGIES LLC, MASON, OH. FILED 10-13-2011.

APEX TRAJECTORY

THE MARK CONSISTS OF STANDARD CHARACTERS WITHOUT CLAIM TO ANY PARTICULAR FONT, STYLE, SIZE, OR COLOR.

FOR COMPUTER SERVICES, NAMELY, PROVIDING A WEB-BASED SYSTEM AND ONLINE PORTAL FEATURING ON-LINE NON-DOWNLOADABLE SOFTWARE FOR USE IN TRACKING, PROCESSING AND PROVIDING USER ACCESS TO DATA RELATING TO DISPENSING, ACCESS AND USAGE OF HARDWARE, PARTS, SUPPLIES, COMPONENTS AND THE LIKE, AND FOR USE IN SUPPLY CHAIN MANAGEMENT, INVENTORY CONTROL, ACCESS CONTROL, DEMAND MANAGEMENT AND PROCESS CONTROL (U.S. CLS. 100, 101 AND 107).

FIRST USE 4-1-2011; IN COMMERCE 4-1-2011.
VIVIAN MICZNIK FIRST, EXAMINING ATTORNEY

CLASS 41—(Continued).

SN 85-446,558. THE UNIVERSITY OF NORTH CAROLINA AT CHAPEL HILL, CHAPEL HILL, NC. FILED 10-13-2011.

MBA @ UNC

THE MARK CONSISTS OF STANDARD CHARACTERS WITHOUT CLAIM TO ANY PARTICULAR FONT, STYLE, SIZE, OR COLOR.

OWNER OF U.S. REG. NO. 1,262,384.

NO CLAIM IS MADE TO THE EXCLUSIVE RIGHT TO USE "MBA", APART FROM THE MARK AS SHOWN.

FOR EDUCATIONAL SERVICES, NAMELY, PROVIDING ONLINE COURSES OF INSTRUCTION, SEMINARS, WORKSHOPS, AND CONFERENCES AT THE UNIVERSITY LEVEL (U.S. CLS. 100, 101 AND 107).

JUSTINE D. PARKER, EXAMINING ATTORNEY

CLASS 41—(Continued).

SN 85-446,762. CURRENT MEDIA, LLC, SAN FRANCISCO, CA. FILED 10-13-2011.

POLITICALLY DIRECT

THE MARK CONSISTS OF STANDARD CHARACTERS WITHOUT CLAIM TO ANY PARTICULAR FONT, STYLE, SIZE, OR COLOR.

FOR CABLE, SATELLITE, TELEVISION, WIRELESS, MOBILE AND INTERNET BROADCASTING SERVICES (U.S. CLS. 100, 101 AND 107).

SALLY SHIH, EXAMINING ATTORNEY

SN 85-446,627. VINO VAN GOGH, INC., SAN ANTONIO, TX. FILED 10-13-2011.

VINO VAN GOGH

THE MARK CONSISTS OF STANDARD CHARACTERS WITHOUT CLAIM TO ANY PARTICULAR FONT, STYLE, SIZE, OR COLOR.

FOR EDUCATION AND ENTERTAINMENT SERVICES, NAMELY, PROVIDING INSTRUCTION IN THE FIELD OF ART (U.S. CLS. 100, 101 AND 107).

FIRST USE 9-19-2011; IN COMMERCE 9-19-2011.
DAVID HOFFMAN, EXAMINING ATTORNEY

SN 85-446,793. VCHERASHANSKY, LUBA, FOREST HILLS, NY. FILED 10-13-2011.

petite gourmet culinary
arts

THE MARK CONSISTS OF STANDARD CHARACTERS WITHOUT CLAIM TO ANY PARTICULAR FONT, STYLE, SIZE, OR COLOR.

NO CLAIM IS MADE TO THE EXCLUSIVE RIGHT TO USE "GOURMET CULINARY ARTS", APART FROM THE MARK AS SHOWN.

FOR EDUCATION SERVICES, NAMELY, PROVIDING CLASSES IN THE FIELD OF COOKING (U.S. CLS. 100, 101 AND 107).

CHRISIE B. KING, EXAMINING ATTORNEY

SN 85-446,714. TASTEFULLY SIMPLE, INC., ALEXANDRIA, MN. FILED 10-13-2011.

INSPIRADA DREAMS

THE MARK CONSISTS OF STANDARD CHARACTERS WITHOUT CLAIM TO ANY PARTICULAR FONT, STYLE, SIZE, OR COLOR.

THE ENGLISH TRANSLATION OF THE WORD "INSPIRADA" IN THE MARK IS "INSPIRED".

FOR EDUCATIONAL SERVICES, NAMELY, PROVIDING GOAL-SETTING AND MOTIVATIONAL TRAINING SERVICES; ONLINE EDUCATIONAL SERVICES, NAMELY, PROVIDING ONLINE SEMINARS, CLASSES AND WORKSHOPS IN THE FIELD OF PERSONAL GROWTH, PERSONAL HAPPINESS, AND PERSONAL MOTIVATION (U.S. CLS. 100, 101 AND 107).

NATALIE POLZER, EXAMINING ATTORNEY

SN 85-446,848. THE TRAVEL TEAM, INC., BUFFALO, NY. FILED 10-13-2011.

INTERPRETRAVEL

THE MARK CONSISTS OF STANDARD CHARACTERS WITHOUT CLAIM TO ANY PARTICULAR FONT, STYLE, SIZE, OR COLOR.

FOR LANGUAGE TRANSLATION SERVICES (U.S. CLS. 100, 101 AND 107).

NATALIE POLZER, EXAMINING ATTORNEY

CLASS 41—(Continued).

SN 85-446,886. GOLD, ELISABETH ANNE, KEALAKEKUA, HI. FILED 10-13-2011.

BUTI

THE MARK CONSISTS OF STANDARD CHARACTERS WITHOUT CLAIM TO ANY PARTICULAR FONT, STYLE, SIZE, OR COLOR.

FOR PHYSICAL FITNESS TRAINING OF INDIVIDUALS AND GROUPS; PROVIDING A WEBSITE FEATURING INFORMATION ON EXERCISE AND FITNESS (U.S. CLS. 100, 101 AND 107).

FIRST USE 6-1-2011; IN COMMERCE 6-1-2011.
YAT SYE, LEE, EXAMINING ATTORNEY

CLASS 41—(Continued).

SN 85-446,928. ELIZABETH WEISS, CHICAGO, IL. FILED 10-13-2011.

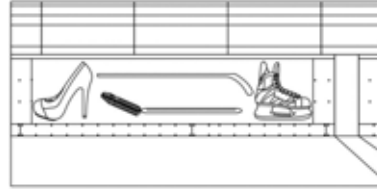

THE MARK CONSISTS OF A PANEL ON THE SIDE BOARD OF A HOCKEY RINK, THE PANEL INCLUDING AN ILLUSTRATION OF A HIGH HEEL SHOE, A HOCKEY SKATE, A HOCKEY STICK, AND A COSMETIC APPLICATOR.

FOR PROVIDING A WEBSITE THAT PROVIDES INFORMATION AND RESOURCES FOR HOCKEY PLAYERS, THEIR FAMILIES, AND THEIR FANS (U.S. CLS. 100, 101 AND 107).

NAKWAMA ANKRAH, EXAMINING ATTORNEY

SN 85-446,948. ROW SHAM BOW, INC., ORLANDO, FL. FILED 10-13-2011.

SN 85-446,918. DISCOVERY COMMUNICATIONS, LLC, SILVER SPRING, MD. FILED 10-13-2011.

WOODLAND HEROES

THE MARK CONSISTS OF STANDARD CHARACTERS WITHOUT CLAIM TO ANY PARTICULAR FONT, STYLE, SIZE, OR COLOR.

FOR ENTERTAINMENT SERVICES, NAMELY, PROVIDING AN ON-LINE COMPUTER GAME (U.S. CLS. 100, 101 AND 107).

JOHN GARTNER, EXAMINING ATTORNEY

REEL CRIME/REAL STORY

SN 85-446,949. CHTCHEVELEV, VAL N., LAS VEGAS, NV. FILED 10-13-2011.

THE MARK CONSISTS OF STANDARD CHARACTERS WITHOUT CLAIM TO ANY PARTICULAR FONT, STYLE, SIZE, OR COLOR.

FOR ENTERTAINMENT AND EDUCATIONAL SERVICES IN THE NATURE OF TELEVISION AND MULTIMEDIA PROGRAM SERIES FEATURING SUBJECTS OF GENERAL HUMAN INTEREST DISTRIBUTED VIA VARIOUS PLATFORMS ACROSS MULTIPLE FORMS OF TRANSMISSION MEDIA; PROVIDING ENTERTAINMENT INFORMATION TO OTHERS VIA A GLOBAL COMPUTER NETWORK (U.S. CLS. 100, 101 AND 107).

MICHELE SWAIN, EXAMINING ATTORNEY

UMATAX

THE MARK CONSISTS OF STANDARD CHARACTERS WITHOUT CLAIM TO ANY PARTICULAR FONT, STYLE, SIZE, OR COLOR.

FOR ENTERTAINMENT INFORMATION; TICKET AGENCY SERVICES FOR ENTERTAINMENT EVENTS (U.S. CLS. 100, 101 AND 107).

FIRST USE 12-5-2010; IN COMMERCE 12-5-2010.
JOHN GARTNER, EXAMINING ATTORNEY

CLASS 41—(Continued).

SN 85-446,974. HWANG, JUNSEOK, IRVINE, CA. AND HWANG, JOONYONG, IRVINE, CA. FILED 10-13-2011.

DIGITALOGY

THE MARK CONSISTS OF STANDARD CHARACTERS WITHOUT CLAIM TO ANY PARTICULAR FONT, STYLE, SIZE, OR COLOR.

FOR BOOK PUBLISHING (U.S. CLS. 100, 101 AND 107).
AMY HELLA, EXAMINING ATTORNEY

SN 85-447,072. WORLD CHAMPION CENTER, INC, RIVERVIEW, FL. FILED 10-13-2011.



NO CLAIM IS MADE TO THE EXCLUSIVE RIGHT TO USE "CENTER", APART FROM THE MARK AS SHOWN.

THE MARK CONSISTS OF THE WORDING "WORLD CHAMPION CENTER" BENEATH AN OVAL-WINGED DESIGN ELEMENT CONTAINING THE STYLIZED LETTERS "WCC".

FOR CONDUCTING AFTER SCHOOL TUTORING PROGRAMS; MARTIAL ARTS INSTRUCTION; OPERATING OF MARTIAL ARTS' SCHOOLS; OPERATING OF MARTIAL ARTS' STUDIOS; PROVIDING A WEB SITE FEATURING NON-DOWNLOADABLE INSTRUCTIONAL VIDEOS IN THE FIELD OF MARTIAL ARTS; PROVIDING AFTER SCHOOL EDUCATIONAL PROGRAMS FOR CHILDREN IN GRADES PRESCHOOL TO 12TH GRADE; PROVIDING AFTER SCHOOL EDUCATIONAL PROGRAMS IN THE FIELD OF TAEKWONDO AND PLAY FACILITIES FOR CHILDREN; PROVIDING CLASSES, WORKSHOPS, SEMINARS AND CAMPS IN THE FIELDS OF FITNESS, EXERCISE, BOXING, KICK BOXING AND MIXED MARTIAL ARTS; PROVIDING GENERAL FITNESS AND MIXED MARTIAL ARTS FACILITIES THAT REQUIRE MEMBERSHIPS AND ARE FOCUSED IN THE FIELDS OF GENERAL FITNESS, EXERCISE, AND MIXED MARTIAL ARTS (U.S. CLS. 100, 101 AND 107).

FIRST USE 1-1-2009. THE MARK WAS FIRST USED ANYWHERE IN A DIFFERENT FORM OTHER THAN THAT SOUGHT TO BE REGISTERED AT LEAST AS EARLY AS 01/01/2008; IN COMMERCE 1-1-2009, THE MARK WAS FIRST USED IN COMMERCE IN A DIFFERENT FORM OTHER THAN THAT SOUGHT TO BE REGISTERED AT LEAST AS EARLY AS 01/01/2008.

GEOFFREY FOSDICK, EXAMINING ATTORNEY

CLASS 41—(Continued).

SN 85-447,109. COMMBRIDGE LANGUAGE SERVICES, GILBERT, AZ. FILED 10-13-2011.

CommBridge

THE MARK CONSISTS OF STANDARD CHARACTERS WITHOUT CLAIM TO ANY PARTICULAR FONT, STYLE, SIZE, OR COLOR.

FOR LANGUAGE TRANSLATION; WRITING OF TEXTS OTHER THAN PUBLICITY TEXTS; WRITTEN TEXT EDITING (U.S. CLS. 100, 101 AND 107).
RON FAIRBANKS, EXAMINING ATTORNEY

SN 85-447,232. TWENTIETH CENTURY FOX FILM CORPORATION, LOS ANGELES, CA. FILED 10-13-2011.

THE FINDER

THE MARK CONSISTS OF STANDARD CHARACTERS WITHOUT CLAIM TO ANY PARTICULAR FONT, STYLE, SIZE, OR COLOR.

FOR ENTERTAINMENT SERVICES IN THE NATURE OF A TELEVISION SERIES FEATURING DRAMA; PROVIDING ON-LINE INFORMATION IN THE FIELD OF TELEVISION AND VIDEO ENTERTAINMENT FEATURING DRAMA VIA THE INTERNET; ENTERTAINMENT SERVICES IN THE NATURE OF NON-DOWNLOADABLE VIDEOS AND IMAGES FEATURING TELEVISION SHOWS TRANSMITTED VIA THE INTERNET AND WIRELESS COMMUNICATION NETWORKS; ON-LINE JOURNALS, NAMELY, BLOGS FEATURING PERSONAL OPINIONS IN THE FIELD OF GENERAL INTEREST AND DRAMA (U.S. CLS. 100, 101 AND 107).

JANICE L. MCMORROW, EXAMINING ATTORNEY

SN 85-447,419. CITY OF WESTFIELD, WESTFIELD, IN. FILED 10-14-2011.

GRAND PARK

THE MARK CONSISTS OF STANDARD CHARACTERS WITHOUT CLAIM TO ANY PARTICULAR FONT, STYLE, SIZE, OR COLOR.

NO CLAIM IS MADE TO THE EXCLUSIVE RIGHT TO USE "PARK", APART FROM THE MARK AS SHOWN.

FOR PROVIDING VARIOUS FACILITIES FOR AN ARRAY OF SPORTING EVENTS, SPORTS AND ATHLETIC COMPETITIONS AND AWARDS PROGRAMMES (U.S. CLS. 100, 101 AND 107).

EDWARD NELSON, EXAMINING ATTORNEY

CLASS 41—(Continued).

SN 85-447,424. FINK IV, RICHARD, BERGEN, NY. FILED 10-14-2011.

THROGA

THE MARK CONSISTS OF STANDARD CHARACTERS WITHOUT CLAIM TO ANY PARTICULAR FONT, STYLE, SIZE, OR COLOR.

FOR EDUCATION SERVICES, NAMELY, PROVIDING LIVE AND ON-LINE CLASSES IN THE FIELD OF VOCAL TRAINING TECHNIQUES; INSTRUCTION IN THE FIELD OF VOCAL TRAINING TECHNIQUES; TEACHING IN THE FIELD OF VOCAL TRAINING TECHNIQUES (U.S. CLS. 100, 101 AND 107).

FIRST USE 2-1-2011; IN COMMERCE 6-1-2011.
JULIE WATSON, EXAMINING ATTORNEY

SN 85-447,430. LISTEN WRITE PRESENT LLC, WILSON, NC. FILED 10-14-2011.

LISTEN WRITE PRESENT

THE MARK CONSISTS OF STANDARD CHARACTERS WITHOUT CLAIM TO ANY PARTICULAR FONT, STYLE, SIZE, OR COLOR.

FOR EDUCATION SERVICES, NAMELY CONDUCTING WORKSHOPS, SEMINARS, LECTURES AND TRAINING IN THE FIELD OF COMMUNICATION, AND THE DISTRIBUTION OF COURSE MATERIALS IN CONNECTION THEREWITH (U.S. CLS. 100, 101 AND 107).

FIRST USE 10-10-2011; IN COMMERCE 10-10-2011.
RICHARD WHITE, EXAMINING ATTORNEY

SN 85-447,500. LION'S CLAW PRODUCTIONS LLC, PALMDALE, CA. FILED 10-14-2011.



NO CLAIM IS MADE TO THE EXCLUSIVE RIGHT TO USE "PRODUCTIONS", APART FROM THE MARK AS SHOWN.

THE COLOR(S) BLACK, BLUE, GRAY, TAN, AND WHITE IS/ARE CLAIMED AS A FEATURE OF THE MARK.

THE MARK CONSISTS OF THE WORDS "LION'S CLAW PRODUCTIONS" IN A STYLIZED BLUE FONT AND

CLASS 41—(Continued).

CIRCLE AND CLAW DESIGN. THE OUTER CIRCLE IS TAN ON THE INSIDE AND CONTAINS THE WORDS "LION'S CLAW PRODUCTIONS". THE LOWER RIGHT SIDE OF THE OUTSIDE CIRCLE HAS A BLACK SHADE ON THE OUTSIDE. THE INNER CIRCLE OF THE MARK IS SHADED BLUE ON THE INSIDE. A LION'S PAW IS PRESENTED INSIDE THE INNER CIRCLE. THE PAW IS TAN WITH A BLACK CENTER AND SHADING WITH A WHITE OUTLINE. THE CLAWS OF THE PAW ARE WHITE AND GRAY.

FOR FILM AND VIDEO PRODUCTION; FILM PRODUCTION (U.S. CLS. 100, 101 AND 107).

FIRST USE 6-0-2011; IN COMMERCE 6-0-2011.
BRIAN PINO, EXAMINING ATTORNEY

SN 85-447,551. BALANCE INTEGRATION CORPORATION, NEW YORK, NY. FILED 10-14-2011.

The Incubator

THE MARK CONSISTS OF STANDARD CHARACTERS WITHOUT CLAIM TO ANY PARTICULAR FONT, STYLE, SIZE, OR COLOR.

FOR EDUCATION SERVICES, NAMELY, PROVIDING CLASSES IN THE FIELD OF STRESS MANAGEMENT AND WELLNESS IMPROVEMENT (U.S. CLS. 100, 101 AND 107).

FIRST USE 8-31-2008; IN COMMERCE 8-31-2008.
MEGHAN REINHART, EXAMINING ATTORNEY

SN 85-447,573. BALANCE INTEGRATION CORPORATION, NEW YORK, NY. FILED 10-14-2011.

OmWork

THE MARK CONSISTS OF STANDARD CHARACTERS WITHOUT CLAIM TO ANY PARTICULAR FONT, STYLE, SIZE, OR COLOR.

FOR EDUCATION SERVICES, NAMELY, PROVIDING CLASSES AND COACHING IN THE FIELD OF WELLNESS, PERSONAL ENERGY MANAGEMENT AND SELF MASTERY (U.S. CLS. 100, 101 AND 107).

FIRST USE 10-31-2002; IN COMMERCE 10-31-2002.
MEGHAN REINHART, EXAMINING ATTORNEY

CLASS 41—(Continued).

SN 85-447,693. REVELLE INDEPENDENT LLC, LOS ANGELES, CA. FILED 10-14-2011.

SAVING AMERICA

THE MARK CONSISTS OF STANDARD CHARACTERS WITHOUT CLAIM TO ANY PARTICULAR FONT, STYLE, SIZE, OR COLOR.

FOR ENTERTAINMENT SERVICES IN THE NATURE OF AN ON-GOING TELEVISION GAME SHOW; PROVIDING ON-LINE INFORMATION IN THE FIELD OF TELEVISION AND VIDEO ENTERTAINMENT FEATURING A TELEVISION GAME SHOW VIA A GLOBAL COMMUNICATIONS NETWORK; ENTERTAINMENT SERVICES IN THE NATURE OF NON-DOWNLOADABLE VIDEOS AND IMAGES FEATURING A TELEVISION GAME SHOW TRANSMITTED VIA THE INTERNET AND WIRELESS COMMUNICATION NETWORKS; ON-LINE JOURNALS, NAMELY, BLOGS FEATURING PERSONAL OPINIONS IN THE FIELD OF GENERAL INTEREST AND A TELEVISION GAME SHOW (U.S. CLS. 100, 101 AND 107).

WILLIAM P. SHANAHAN, EXAMINING ATTORNEY

CLASS 41—(Continued).

SN 85-447,704. K2 NETWORK, INC., IRVINE, CA. FILED 10-14-2011.



THE COLOR(S) BLUE, WHITE, GOLD AND BLACK IS/ARE CLAIMED AS A FEATURE OF THE MARK.

THE MARK CONSISTS OF A BLUE STYLIZED ORB COVERED WITH LINES OF WHITE LIGHTENING DESIGNS OVER WHICH APPEAR THE WORDS "HAILAN RISING" IN GOLD LETTERING OUTLINED BY A BLACK SHADOW.

THE WORDING "HAILAN" HAS NO MEANING IN A FOREIGN LANGUAGE.

FOR ENTERTAINMENT SERVICES, NAMELY, PROVIDING COMPETITIVE MULTI-PLAYER VIDEO GAMING VIA A GLOBAL COMPUTER NETWORK (U.S. CLS. 100, 101 AND 107).

DEBORAH LOBO, EXAMINING ATTORNEY

SN 85-447,708. K2 NETWORK, INC., IRVINE, CA. FILED 10-14-2011.

SN 85-447,698. K2 NETWORK, INC., IRVINE, CA. FILED 10-14-2011.



THE COLOR(S) RED, BLACK, GOLD AND WHITE IS/ARE CLAIMED AS A FEATURE OF THE MARK.

THE MARK CONSISTS OF A RED STYLIZED ORB COVERED WITH LINES OF WHITE LIGHTENING DESIGNS OVER WHICH APPEAR THE WORDS "HAILAN RISING" IN GOLD LETTERING OUTLINED BY A BLACK SHADOW.

THE WORDING "HAILAN" HAS NO MEANING IN A FOREIGN LANGUAGE.

FOR ENTERTAINMENT SERVICES, NAMELY, PROVIDING COMPETITIVE MULTI-PLAYER VIDEO GAMING VIA A GLOBAL COMPUTER NETWORK (U.S. CLS. 100, 101 AND 107).

DEBORAH LOBO, EXAMINING ATTORNEY



THE COLOR(S) RED, WHITE, GOLD AND BLACK IS/ARE CLAIMED AS A FEATURE OF THE MARK.

THE MARK CONSISTS OF A RED STYLIZED ORB COVERED WITH LINES OF WHITE LIGHTENING DESIGNS OVER WHICH APPEAR THE WORDS "HAILAN" ABOVE THE WORD "RISING" IN GOLD LETTERING OUTLINED BY A BLACK SHADOW.

THE WORDING "HAILAN" HAS NO MEANING IN A FOREIGN LANGUAGE.

FOR ENTERTAINMENT SERVICES, NAMELY, PROVIDING COMPETITIVE MULTI-PLAYER VIDEO GAMING VIA A GLOBAL COMPUTER NETWORK (U.S. CLS. 100, 101 AND 107).

DEBORAH LOBO, EXAMINING ATTORNEY

CLASS 41—(Continued).

SN 85-447,711. K2 NETWORK, INC., IRVINE, CA. FILED 10-14-2011.



THE COLOR(S) BLUE, GOLD, WHITE AND BLACK IS/ARE CLAIMED AS A FEATURE OF THE MARK.

THE MARK CONSISTS OF A BLUE STYLIZED ORB COVERED WITH LINES OF WHITE LIGHTENING DESIGNS AND A BLACK SHADOW OUTLINE OVER WHICH THE WORDS "AVENTURA ETERNA" APPEAR IN GOLD AND WHITE LETTERING CONTAINING BLUE CRACKS.

THE ENGLISH TRANSLATION OF "AVENTURA ETERNA" IS "ETERNAL ADVENTURE".

FOR ENTERTAINMENT SERVICES, NAMELY, PROVIDING AN ON-LINE COMPUTER GAME (U.S. CLS. 100, 101 AND 107).

DEBORAH LOBO, EXAMINING ATTORNEY

SN 85-447,799. JOSEPH FIORE, BROOKLYN, NY. FILED 10-14-2011.



THE COLOR(S) GRAY AND BLACK IS/ARE CLAIMED AS A FEATURE OF THE MARK.

THE MARK CONSISTS OF THE STYLIZED TERM "FURBALL" IN GRAY WITH BLACK SHADING AND APPEARING ON A BLACK BACKGROUND.

FOR ENTERTAINMENT SERVICES, NAMELY, CONDUCTING DANCE PARTIES CATERING TO GAY MEN (U.S. CLS. 100, 101 AND 107).

FIRST USE 2-15-1995; IN COMMERCE 3-1-1995.

JESSICA A. POWERS, EXAMINING ATTORNEY

SN 85-447,852. CHEEZBURGER, INC., SEATTLE, WA. FILED 10-14-2011.

MEMEBASE

THE MARK CONSISTS OF STANDARD CHARACTERS WITHOUT CLAIM TO ANY PARTICULAR FONT, STYLE, SIZE, OR COLOR.

FOR ENTERTAINMENT SERVICES, NAMELY, PROVIDING A WEB SITE FEATURING NON-DOWNLOADABLE TEXT, PHOTOS, VIDEOS AND OTHER AUDIOVISUAL MATERIAL OF A COMEDIC NATURE (U.S. CLS. 100, 101 AND 107).

FIRST USE 10-7-2010; IN COMMERCE 10-7-2010.

KIMBERLY FRYE, EXAMINING ATTORNEY

CLASS 41—(Continued).

SN 85-447,961. LAVETTA WILLIS, LOS ANGELES, CA. FILED 10-14-2011.

TURBO LINE DANCING

THE MARK CONSISTS OF STANDARD CHARACTERS WITHOUT CLAIM TO ANY PARTICULAR FONT, STYLE, SIZE, OR COLOR.

NO CLAIM IS MADE TO THE EXCLUSIVE RIGHT TO USE "LINE DANCING", APART FROM THE MARK AS SHOWN.

FOR ENTERTAINMENT IN THE NATURE OF LINE DANCING; CONDUCTING FITNESS CLASSES FEATURING LINE DANCING; INSTRUCTION OF DANCE (U.S. CLS. 100, 101 AND 107).

AMY KERTGATE, EXAMINING ATTORNEY

SN 85-447,970. DEEPBLUE WORLDS INC., SHERMAN OAKS, CA. FILED 10-14-2011.

XPLORE

THE MARK CONSISTS OF STANDARD CHARACTERS WITHOUT CLAIM TO ANY PARTICULAR FONT, STYLE, SIZE, OR COLOR.

FOR ENTERTAINMENT SERVICES, NAMELY, PROVIDING ON-LINE COMPUTER GAMES FEATURING ONLINE VIRTUAL WORDS FOR CHILDREN THAT PROMOTE LEARNING THROUGH PUZZLES AND GAMES (U.S. CLS. 100, 101 AND 107).

AMY KERTGATE, EXAMINING ATTORNEY

SN 85-447,979. MERLA, CARLOS, GRAPEVINE, TX. FILED 10-14-2011.

LEAD IT 2 WIN IT

THE MARK CONSISTS OF STANDARD CHARACTERS WITHOUT CLAIM TO ANY PARTICULAR FONT, STYLE, SIZE, OR COLOR.

FOR EDUCATION SERVICES, NAMELY, PROVIDING TRAINING, CLASSES, SEMINARS, AND WORKSHOPS IN THE FIELD OF LEADERSHIP AND EXECUTIVE COACHING (U.S. CLS. 100, 101 AND 107).

ESTHER A. BORSUK, EXAMINING ATTORNEY

CLASS 41—(Continued).

SN 85-448,010. MED MOBILE, INC., FOUNTAIN VALLEY, CA. FILED 10-14-2011.

ARHQ

THE MARK CONSISTS OF STANDARD CHARACTERS WITHOUT CLAIM TO ANY PARTICULAR FONT, STYLE, SIZE, OR COLOR.

FOR AUGMENTED REALITY VIDEO PRODUCTION; MULTIMEDIA ENTERTAINMENT SERVICES IN THE NATURE OF RECORDING, PRODUCTION AND POST-PRODUCTION SERVICES IN THE FIELDS OF MUSIC, VIDEO, AND FILMS; PRODUCTION OF SOUND AND MUSIC VIDEO RECORDINGS; PRODUCTION OF VIDEO AND COMPUTER GAME SOFTWARE; PROVIDING FACILITIES FOR PRODUCING VIDEO, CINEMA AND PHOTOGRAPHY PRODUCTIONS; PROVIDING INFORMATION ON-LINE RELATING TO COMPUTER GAMES AND COMPUTER ENHANCEMENTS FOR GAMES; PROVIDING ONLINE AUGMENTED REALITY GAMES; VIDEO ARCADE SERVICES (U.S. CLS. 100, 101 AND 107).

STEPHANIE ALI, EXAMINING ATTORNEY

CLASS 41—(Continued).

SN 85-448,245. ROTO SPORTS, INC., MADISON, WI. FILED 10-14-2011.

ROTOWIRE.COM

THE MARK CONSISTS OF STANDARD CHARACTERS WITHOUT CLAIM TO ANY PARTICULAR FONT, STYLE, SIZE, OR COLOR.

FOR ENTERTAINMENT SERVICES IN THE NATURE OF FANTASY SPORTS LEAGUES; PROVIDING NEWS AND INFORMATION IN THE FIELD OF SPORTS (U.S. CLS. 100, 101 AND 107).

FIRST USE 4-1-2001; IN COMMERCE 4-1-2001.

JENNIFER WILLISTON, EXAMINING ATTORNEY

SN 85-448,017. KELLY, JOHN J., NEW ORLEANS, LA. FILED 10-14-2011.

KREWE OF LAFCADIO

THE MARK CONSISTS OF STANDARD CHARACTERS WITHOUT CLAIM TO ANY PARTICULAR FONT, STYLE, SIZE, OR COLOR.

NO CLAIM IS MADE TO THE EXCLUSIVE RIGHT TO USE "KREWE", APART FROM THE MARK AS SHOWN.

"LAFCADIO" DOES NOT REPRESENT THE NAME OF A LIVING INDIVIDUAL. THE TERM "LAFCADIO" REFERS TO "LAFCADIO" HEARN, NOW DECEASED.

FOR ENTERTAINMENT SERVICES IN THE NATURE OF MARDI GRAS PARADE PERFORMANCES (U.S. CLS. 100, 101 AND 107).

ZHALEH DELANEY, EXAMINING ATTORNEY

SN 85-448,295. POTENTIAL CONNECTIONS, LLC, DOVER, NH. FILED 10-15-2011.



THE COLOR(S) PURPLE, GREEN AND WHITE IS/ARE CLAIMED AS A FEATURE OF THE MARK.

THE MARK CONSISTS OF A PURPLE CIRCLE INSIDE A WHITE CIRCLE INSIDE A GREEN CIRCLE WHICH IS INSIDE A PURPLE CIRCLE. IN THE CENTER PURPLE CIRCLE ARE THE WORDS "I CAN HELP" WITH THE "I" IN GREEN AND "CAN HELP" IN WHITE. IN THE GREEN CIRCLE IS THE WHITE WORDING "I UNDERSTAND" AND "I AM COMMITTED". THE PHRASES ARE SEPARATED BY TWO WHITE LEAF SHAPES.

FOR EDUCATION SERVICES, NAMELY, PROVIDING LIVE AND ON-LINE WORKSHOPS, PROFESSIONAL DEVELOPMENT TRAINING AND COMMUNITY TRAINING IN THE FIELD OF CREATING SAFE PLACES IN OUR COMMUNITIES FOR ADOLESCENTS TO SELF-IDENTIFY POTENTIAL MENTAL HEALTH OR SUBSTANCE USE BEHAVIORS (U.S. CLS. 100, 101 AND 107).

FIRST USE 2-20-2011; IN COMMERCE 5-6-2011.

AMY HELLA, EXAMINING ATTORNEY

SN 85-448,145. PLYOKICK LLC, FEDERAL WAY, WA. FILED 10-14-2011.

Plyokick

THE MARK CONSISTS OF STANDARD CHARACTERS WITHOUT CLAIM TO ANY PARTICULAR FONT, STYLE, SIZE, OR COLOR.

FOR PHYSICAL FITNESS INSTRUCTION (U.S. CLS. 100, 101 AND 107).

FIRST USE 3-1-2011; IN COMMERCE 3-1-2011.

LINDA POWELL, EXAMINING ATTORNEY

CLASS 41—(Continued).

SN 85-448,410. BRIARWOOD STUDIOS OF ATHENS LLC, ATHENS, OH. FILED 10-16-2011.

ArtBreak

THE MARK CONSISTS OF STANDARD CHARACTERS WITHOUT CLAIM TO ANY PARTICULAR FONT, STYLE, SIZE, OR COLOR.

FOR EDUCATION SERVICES, NAMELY, PROVIDING CLASSES, TRAINING, SESSIONS AND WORKSHOPS IN THE FIELD OF CHOICE-BASED STUDIO ART WITHIN THE FRAMEWORK OF THE EXPRESSIVE THERAPIES CONTINUUM (U.S. CLS. 100, 101 AND 107).

FIRST USE 9-16-2009; IN COMMERCE 7-6-2011.
FRED CARL, EXAMINING ATTORNEY

SN 85-448,477. WHATAGOODDOG! LLC, DBA WHATAGREATDOG! TRAINING CENTER, PROSPER, TX. FILED 10-16-2011.

What a Great Dog!

THE MARK CONSISTS OF STANDARD CHARACTERS WITHOUT CLAIM TO ANY PARTICULAR FONT, STYLE, SIZE, OR COLOR.

FOR DOG TRAINING (U.S. CLS. 100, 101 AND 107).
FIRST USE 2-1-2010; IN COMMERCE 2-1-2010.
JILL C. ALT, EXAMINING ATTORNEY

CLASS 41—(Continued).

SN 85-448,485. JESSE GEORGE SERGIOS, GRAND CAYMAN, CAYMAN ISLANDS, FILED 10-17-2011.

SUNSONIC

THE MARK CONSISTS OF STANDARD CHARACTERS WITHOUT CLAIM TO ANY PARTICULAR FONT, STYLE, SIZE, OR COLOR.

FOR ARRANGING, ORGANIZING, CONDUCTING, AND HOSTING SOCIAL ENTERTAINMENT EVENTS; ENTERTAINMENT IN THE NATURE OF VISUAL AND AUDIO PERFORMANCES, NAMELY, MUSICAL BAND, ROCK GROUP, GYMNASTIC, DANCE, AND BALLET PERFORMANCES; ENTERTAINMENT SERVICES IN THE NATURE OF LIVE MUSICAL PERFORMANCES; ENTERTAINMENT SERVICES IN THE NATURE OF PRESENTING LIVE MUSICAL PERFORMANCES; ENTERTAINMENT SERVICES, NAMELY, CONDUCTING PARTIES; ENTERTAINMENT, NAMELY, LIVE MUSIC CONCERTS; ENTERTAINMENT, NAMELY, LIVE PERFORMANCES BY MUSICAL BANDS; MULTIMEDIA ENTERTAINMENT SERVICES IN THE NATURE OF RECORDING, PRODUCTION AND POST-PRODUCTION SERVICES IN THE FIELDS OF MUSIC, VIDEO, AND FILMS; ORGANIZATION OF EXHIBITIONS FOR MUSICAL ENTERTAINMENT; POST-PRODUCTION EDITING SERVICES IN THE FIELD OF MUSIC, VIDEOS AND FILM; PRESENTATION OF MUSICAL PERFORMANCE; PRODUCTION OF MUSICAL SOUND RECORDING; PRODUCTION OF MUSICAL VIDEOS; PRODUCTION OF SOUND AND MUSIC VIDEO RECORDINGS; PROVIDING A WEB SITE WHERE USERS CAN POST RATINGS, REVIEWS AND RECOMMENDATIONS ON EVENTS AND ACTIVITIES IN THE FIELD OF ENTERTAINMENT AND EDUCATION; PROVIDING A WEBSITE FEATURING INFORMATION IN THE FIELD OF MUSIC AND ENTERTAINMENT; PROVIDING A WEBSITE FOR ENTERTAINMENT PURPOSES WHERE USERS CAN VIEW AND POST VIDEOS FEATURING MUSICAL BANDS; PROVIDING AN INTERNET WEBSITE PORTAL IN THE FIELD OF MUSIC (U.S. CLS. 100, 101 AND 107).

JENNY PARK, EXAMINING ATTORNEY

SN 85-448,497. IT DATAWORKS, LLC, TULSA, OK. FILED 10-17-2011.

AMERICAN MAFIA

THE MARK CONSISTS OF STANDARD CHARACTERS WITHOUT CLAIM TO ANY PARTICULAR FONT, STYLE, SIZE, OR COLOR.

FOR ENTERTAINMENT SERVICES, NAMELY, PROVIDING AN ON-LINE COMPUTER GAME (U.S. CLS. 100, 101 AND 107).

FIRST USE 5-5-2006; IN COMMERCE 5-5-2006.
KELLY CHOE, EXAMINING ATTORNEY

CLASS 41—(Continued).

SN 85-448,568. STACY, MICHAEL, DAYTON, OH. FILED 10-17-2011.

GATHERING MERCURY

THE MARK CONSISTS OF STANDARD CHARACTERS WITHOUT CLAIM TO ANY PARTICULAR FONT, STYLE, SIZE, OR COLOR.

FOR ENTERTAINMENT, NAMELY, LIVE PERFORMANCES BY A MUSICAL BAND (U.S. CLS. 100, 101 AND 107).

NAKIA HENRY, EXAMINING ATTORNEY

SN 85-448,570. CAPE TO CAIRO SAFARI LOUNGE, ROSWELL, GA. FILED 10-17-2011.

UNDER AFRICAN SKIES

THE MARK CONSISTS OF STANDARD CHARACTERS WITHOUT CLAIM TO ANY PARTICULAR FONT, STYLE, SIZE, OR COLOR.

FOR FILM AND VIDEO PRODUCTION; MUSIC PRODUCTION SERVICES; MUSIC VIDEO PRODUCTION (U.S. CLS. 100, 101 AND 107).

NAKIA HENRY, EXAMINING ATTORNEY

SN 85-448,642. TREE-MENDOUS FOREST INC., AKA TREE-MENDOUS FOREST ADVENTURE PARK INC., GHENT, NY. FILED 10-17-2011.

Tree-Mendous Forest

THE MARK CONSISTS OF STANDARD CHARACTERS WITHOUT CLAIM TO ANY PARTICULAR FONT, STYLE, SIZE, OR COLOR.

FOR AMUSEMENT PARK AND THEME PARK SERVICES; AMUSEMENT PARKS; PROVIDING AMUSEMENT PARKS; PROVIDING THEME PARK SERVICES; PROVISION OF INFORMATION RELATING TO AMUSEMENT PARK SHOWS; RECREATIONAL PARK SERVICES (U.S. CLS. 100, 101 AND 107).

CHRIS WELLS, EXAMINING ATTORNEY

CLASS 41—(Continued).

SN 85-448,705. DIETZLER, SOREL, CARLSBAD, CA. FILED 10-17-2011.

KANGAROO KONSCIOUSNESS

THE MARK CONSISTS OF STANDARD CHARACTERS WITHOUT CLAIM TO ANY PARTICULAR FONT, STYLE, SIZE, OR COLOR.

NO CLAIM IS MADE TO THE EXCLUSIVE RIGHT TO USE "CONSCIOUSNESS", APART FROM THE MARK AS SHOWN.

FOR CONDUCTING WORKSHOPS AND SEMINARS IN PERSONAL AWARENESS (U.S. CLS. 100, 101 AND 107).

FIRST USE 8-2-2011; IN COMMERCE 8-2-2011.

KATHLEEN LORENZO, EXAMINING ATTORNEY

SN 85-448,741. BIG CAT ENTERTAINMENT, INC., CINCINNATI, OH. FILED 10-17-2011.

MY MOODIES

THE MARK CONSISTS OF STANDARD CHARACTERS WITHOUT CLAIM TO ANY PARTICULAR FONT, STYLE, SIZE, OR COLOR.

FOR ENTERTAINMENT SERVICES, NAMELY, AN ON-GOING SERIES FEATURING PROGRAMS FOR PRE-TEEN AND TEEN AGED YOUNG PEOPLE PROVIDED THROUGH THE INTERNET AND TELEVISION (U.S. CLS. 100, 101 AND 107).

TARAH HARDY, EXAMINING ATTORNEY

CLASS 41—(Continued).

SN 85-448,789. LANCASTER UNIVERSITY, LANCASTER LA1 4YW, UNITED KINGDOM, FILED 10-17-2011.

**CONTROLLED COGNITIVE
ENGAGEMENT**

THE MARK CONSISTS OF STANDARD CHARACTERS WITHOUT CLAIM TO ANY PARTICULAR FONT, STYLE, SIZE, OR COLOR.

FOR EDUCATIONAL SERVICES, NAMELY, CONDUCTING TRAINING COURSES AND SEMINARS IN THE FIELD OF SECURITY OPERATIONS AND SERVICE, AT THE END OF WHICH STUDENTS RECEIVE A CERTIFICATE NOTING TRAINING COMPLETION AND DISTRIBUTION OF EDUCATIONAL MATERIALS IN CONNECTION THEREWITH; TRAINING IN THE USE AND OPERATION OF AIRPORT SECURITY DEVICES; TRAINING SERVICES IN THE FIELD OF SECURITY OPERATIONS AND SERVICE, PERSONAL SECURITY, AIRPORT BAGGAGE SECURITY INSPECTION SERVICES, FRAUD AND IDENTITY THEFT PROTECTION SERVICES, AIRPORT SECURITY SERVICES, NAMELY, SECURITY CONTROL OF PERSONS AND LUGGAGE IN AIRPORTS, SECURITY INSPECTION AUDITS, BORDER SECURITY SERVICES, BACKGROUND SCREENING OF PERSONNEL AND PASSENGERS, AIRPORT SECURITY SYSTEMS, AND RISK ASSESSMENT PERTAINING TO AIRPORT LAYOUTS AND SECURITY DEPLOYMENT (U.S. CLS. 100, 101 AND 107).

TARAH HARDY, EXAMINING ATTORNEY

SN 85-448,867. ARMADILLO, INC., BOZEMAN, MT. FILED 10-17-2011.



THE MARK CONSISTS OF THE WORDS "THE MUSIC STORE" WHEREIN "THE" IS ABOVE AND SLIGHTLY TO THE LEFT OF "MUSIC" WHICH IS IN TURN ABOVE AND SLIGHTLY TO THE LEFT OF "STORE" AND IN PLACE OF THE LETTER "O" IN "STORE" IS THE SHAPE OF A GUITAR.

FOR ENTERTAINMENT SERVICES, NAMELY, AN ON-GOING SERIES FEATURING COMEDY, DOCUMENTARY, AND REALITY-BASED EPISODES PROVIDED THROUGH TELEVISION; ENTERTAINMENT SERVICES, NAMELY, PROVIDING ON-GOING WEBSITES FEATURING COMEDY, DOCUMENTARY, AND REALITY-BASED SEGMENTS VIA A GLOBAL COMPUTER NETWORK (U.S. CLS. 100, 101 AND 107).

FIRST USE 4-26-2011; IN COMMERCE 4-26-2011.
BERNICE MIDDLETON, EXAMINING ATTORNEY

CLASS 41—(Continued).

SN 85-448,889. LAURIA, FRANKE NIKLAS, SAN DIEGO, CA. FILED 10-17-2011.



THE STIPPLING IS FOR SHADING PURPOSES ONLY.

THE MARK CONSISTS OF A CIRCLE CONTAINING A PAIR OF VERTICALLY-REFLECTED QUESTION MARKS JOINED AT THEIR PERIOD-BASE. JUST ABOVE AND BEHIND THESE MARKS IS A STARBURST RISING. BELOW THESE MARKS ARE TWO HORIZONTALLY-REFLECTED PENROSE TRIANGLES. THE PENROSE TRIANGLES MAKE THE CENTER OF A LAUREL WREATH WHICH CIRCLES EITHER SIDE OF THE QUESTION MARKS. THE WREATH STOPS JUST AFTER THE TOP OF THE QUESTION MARKS BUT BEFORE THE RAYS OF THE STARBURST.

FOR EDUCATION SERVICES, NAMELY, PROVIDING LIVE AND ON-LINE CLASSES, SEMINARS, WORKSHOPS AND VIDEOS IN THE FIELD OF PHILOSOPHY, LOGIC AND CRITICAL THINKING (U.S. CLS. 100, 101 AND 107).

ALAIN LAPTER, EXAMINING ATTORNEY

SN 85-448,930. RICHMOND CREATIVE GROUP, LLC, WINDHAM, ME. FILED 10-17-2011.

OLDE ENGLAND

THE MARK CONSISTS OF STANDARD CHARACTERS WITHOUT CLAIM TO ANY PARTICULAR FONT, STYLE, SIZE, OR COLOR.

FOR AMUSEMENT PARK AND THEME PARK SERVICES; AMUSEMENT PARKS; ENTERTAINMENT SERVICES, NAMELY, ARRANGING AND CONDUCTING SPECIAL EVENTS AT AN AMUSEMENT PARK; PROVIDING THEME PARK SERVICES; RECREATIONAL PARK SERVICES (U.S. CLS. 100, 101 AND 107).

JASON BLAIR, EXAMINING ATTORNEY

CLASS 41—(Continued).

SN 85-448,948. SPASSION LLC, MIAMI, FL. FILED 10-17-2011.



THE MARK CONSISTS OF THE NUMBER "5" IN A CIRCLE FOLLOWED BY THE WORD "PASSION" WITHOUT A SPACE. THE TWO "S"'S IN THE WORD "PASSION" ARE SUPERIMPOSED IN A WAY AS TO IMPLY A SPELLING OF THE WORD WITH EITHER ONE OR TWO "S"'S, REFLECTING THE DIFFERING SPELLING OF THE WORD "PASSION" IN BOTH ENGLISH AND SPANISH.

FOR ENTERTAINMENT SERVICES BY A MUSICAL ARTIST AND PRODUCER, NAMELY, MUSICAL COMPOSITION FOR OTHERS AND PRODUCTION OF MUSICAL SOUND RECORDINGS (U.S. CLS. 100, 101 AND 107).

FIRST USE 11-17-2010; IN COMMERCE 11-17-2010.
TINA MAI, EXAMINING ATTORNEY

SN 85-448,960. GO LONG ENDURANCE LLC, RIDGEWOOD, NJ. FILED 10-17-2011.

How bad do you want it?

THE MARK CONSISTS OF STANDARD CHARACTERS WITHOUT CLAIM TO ANY PARTICULAR FONT, STYLE, SIZE, OR COLOR.

FOR SPORTS TRAINING SERVICES (U.S. CLS. 100, 101 AND 107).

DAWN FELDMAN, EXAMINING ATTORNEY

SN 85-448,961. RICHMOND CREATIVE GROUP, LLC, WINDHAM, ME. FILED 10-17-2011.

OLDE SPAIN

THE MARK CONSISTS OF STANDARD CHARACTERS WITHOUT CLAIM TO ANY PARTICULAR FONT, STYLE, SIZE, OR COLOR.

FOR AMUSEMENT PARK AND THEME PARK SERVICES; AMUSEMENT PARKS; ENTERTAINMENT SERVICES, NAMELY, ARRANGING AND CONDUCTING SPECIAL EVENTS AT AN AMUSEMENT PARK; PROVIDING THEME PARK SERVICES; RECREATIONAL PARK SERVICES (U.S. CLS. 100, 101 AND 107).

JASON BLAIR, EXAMINING ATTORNEY

CLASS 41—(Continued).

SN 85-448,988. RICHMOND CREATIVE GROUP, LLC, WINDHAM, ME. FILED 10-17-2011.

PHANTOM KNIGHT

THE MARK CONSISTS OF STANDARD CHARACTERS WITHOUT CLAIM TO ANY PARTICULAR FONT, STYLE, SIZE, OR COLOR.

FOR AMUSEMENT PARK AND THEME PARK SERVICES; AMUSEMENT PARKS; ENTERTAINMENT SERVICES, NAMELY, ARRANGING AND CONDUCTING SPECIAL EVENTS AT AN AMUSEMENT PARK; PROVIDING THEME PARK SERVICES; RECREATIONAL PARK SERVICES (U.S. CLS. 100, 101 AND 107).

JASON BLAIR, EXAMINING ATTORNEY

SN 85-449,061. DANIEL MORRIS, WASHINGTON, DC. FILED 10-17-2011.

JR EXECS

THE MARK CONSISTS OF STANDARD CHARACTERS WITHOUT CLAIM TO ANY PARTICULAR FONT, STYLE, SIZE, OR COLOR.

FOR EDUCATION SERVICES, NAMELY, PROVIDING LIVE AND ON-LINE CLASSES, WEBINARS, AND WORKSHOPS IN THE FIELD OF PARENTING AND EDUCATING YOUNG ENTREPRENEURS IN THE FIELD OF BUSINESS AND DISTRIBUTION OF COURSE MATERIAL IN CONNECTION THEREWITH (U.S. CLS. 100, 101 AND 107).

SUSAN LESLIE DUBOIS, EXAMINING ATTORNEY

SN 85-449,090. SOCIALTRADE CORPORATION, DBA SOCIALTRADE CORPORATION, PALO ALTO, CA. FILED 10-17-2011.

Slope of Hope

THE MARK CONSISTS OF STANDARD CHARACTERS WITHOUT CLAIM TO ANY PARTICULAR FONT, STYLE, SIZE, OR COLOR.

FOR ON-LINE JOURNALS, NAMELY, BLOGS FEATURING MARKET ANALYSIS AND COMMENTARY (U.S. CLS. 100, 101 AND 107).

FIRST USE 3-29-2005; IN COMMERCE 3-29-2005.

ALEX KEAM, EXAMINING ATTORNEY

CLASS 41—(Continued).

SN 85-449,154. CROWDSTAR INTERNATIONAL LIMITED, BLACKROCK, CO. DUBLIN, IRELAND, FILED 10-17-2011.

**CROWDSTAR'S WASTELAND
EMPIRES**

THE MARK CONSISTS OF STANDARD CHARACTERS WITHOUT CLAIM TO ANY PARTICULAR FONT, STYLE, SIZE, OR COLOR.

OWNER OF U.S. REG. NOS. 3,800,884, 3,987,205 AND OTHERS.

FOR ENTERTAINMENT SERVICES, NAMELY, PROVIDING TEMPORARY USE OF NON-DOWNLOADABLE ELECTRONIC GAMES (U.S. CLS. 100, 101 AND 107).
SUNG IN, EXAMINING ATTORNEY

SN 85-449,245. FEDER, KENNETH, PUNTA GORDA, FL. FILED 10-17-2011.

Goldtones

THE MARK CONSISTS OF STANDARD CHARACTERS WITHOUT CLAIM TO ANY PARTICULAR FONT, STYLE, SIZE, OR COLOR.

FOR LIVE PERFORMANCES BY A MUSICAL GROUP (U.S. CLS. 100, 101 AND 107).

FIRST USE 9-15-2009; IN COMMERCE 1-0-2010.
JOHN GARTNER, EXAMINING ATTORNEY

SN 85-449,320. SHARP AS A TACK, INC., CHICAGO, IL. FILED 10-17-2011.

PLAY WITH PURPOSE

THE MARK CONSISTS OF THE STYLIZED TEXT "PLAY WITH PURPOSE".

FOR EDUCATIONAL SERVICES, NAMELY, CONDUCTING PROGRAMS IN THE FIELD OF BEFORE, DURING AND AFTER-SCHOOL PROGRAMMING (U.S. CLS. 100, 101 AND 107).

FIRST USE 8-23-2008; IN COMMERCE 8-23-2008.
NAPOLEON SHARMA, EXAMINING ATTORNEY

CLASS 41—(Continued).

SN 85-449,436. TAYLOR, DALTON, CLEVELAND, VA. FILED 10-18-2011.

VINDICATED

THE MARK CONSISTS OF STANDARD CHARACTERS WITHOUT CLAIM TO ANY PARTICULAR FONT, STYLE, SIZE, OR COLOR.

FOR ENTERTAINMENT, NAMELY, LIVE PERFORMANCES BY A MUSICAL BAND (U.S. CLS. 100, 101 AND 107).

FIRST USE 8-1-2010; IN COMMERCE 9-5-2010.
WILLIAM VERHOSEK, EXAMINING ATTORNEY

SN 85-449,459. CHATHAM COMMUNICATIONS CORPORATION, VICTOR, NY. FILED 10-18-2011.

NO PRACTICE SUNDAY

THE MARK CONSISTS OF STANDARD CHARACTERS WITHOUT CLAIM TO ANY PARTICULAR FONT, STYLE, SIZE, OR COLOR.

FOR EDUCATIONAL AND ENTERTAINMENT SERVICES, NAMELY, PROVIDING MOTIVATIONAL AND EDUCATIONAL SPEAKERS IN THE FIELD OF SELF- AND PERSONAL IMPROVEMENT (U.S. CLS. 100, 101 AND 107).

WILLIAM VERHOSEK, EXAMINING ATTORNEY

SN 85-449,466. OSBORN, DAN, BIG BEAR LAKE, CA. FILED 10-18-2011.

FIERCE WITH AGE

THE MARK CONSISTS OF STANDARD CHARACTERS WITHOUT CLAIM TO ANY PARTICULAR FONT, STYLE, SIZE, OR COLOR.

FOR CONDUCTING WORKSHOPS AND SEMINARS IN PERSONAL AWARENESS; EDUCATIONAL AND ENTERTAINMENT SERVICES, NAMELY, PROVIDING MOTIVATIONAL AND EDUCATIONAL SPEAKERS IN THE FIELD OF SELF- AND PERSONAL IMPROVEMENT; EDUCATIONAL AND ENTERTAINMENT SERVICES, NAMELY, PROVIDING MOTIVATIONAL SPEAKING SERVICES IN THE FIELD OF LIFE IMPROVEMENT AND AGE ADJUSTMENT; PERSONAL COACHING SERVICES IN THE FIELD OF LIFE IMPROVEMENT AND AGE ADJUSTMENT (U.S. CLS. 100, 101 AND 107).

JENNIFER DIXON, EXAMINING ATTORNEY

CLASS 41—(Continued).

SN 85-449,524. MCCARTHY, KEVIN, VIENNA, VA. FILED 10-18-2011.

Nerd Tears

THE MARK CONSISTS OF STANDARD CHARACTERS WITHOUT CLAIM TO ANY PARTICULAR FONT, STYLE, SIZE, OR COLOR.

FOR ENTERTAINMENT SERVICES, NAMELY, PROVIDING ON-LINE REVIEWS OF MOVIES; PROVIDING ONLINE INTERVIEWS FEATURING CELEBRITIES, MOVIE CAST MEMBERS IN THE FIELD OF MOVIES FOR ENTERTAINMENT PURPOSES (U.S. CLS. 100, 101 AND 107).

FIRST USE 10-7-2011; IN COMMERCE 10-7-2011.
CURTIS FRENCH, EXAMINING ATTORNEY

SN 85-449,572. MRW HOLDINGS, LLC, SANTA MONICA, CA. FILED 10-18-2011.

DIRTY TRUTH

THE MARK CONSISTS OF STANDARD CHARACTERS WITHOUT CLAIM TO ANY PARTICULAR FONT, STYLE, SIZE, OR COLOR.

FOR ENTERTAINMENT SERVICES IN THE NATURE OF AN ON-GOING REALITY BASED TELEVISION PROGRAM; ENTERTAINMENT SERVICES, NAMELY, PROVIDING A WEB SITE FEATURING PHOTOGRAPHIC, AUDIO, VIDEO AND PROSE PRESENTATIONS OF NEWS ABOUT WORK ATTITUDES, DIFFICULT OR OBSCURE JOBS AND THE FIELD OF LABOR AND EMPLOYMENT (U.S. CLS. 100, 101 AND 107).

IRA J. GOODSAD, EXAMINING ATTORNEY

SN 85-449,574. BEAVERUN FOUNDERS DEVELOPMENT, LLC, WAMPUM, PA. FILED 10-18-2011.



NO CLAIM IS MADE TO THE EXCLUSIVE RIGHT TO USE "INTERNATIONAL RACE COMPLEX", APART FROM THE MARK AS SHOWN.

THE MARK CONSISTS OF THE WORD "PITTSBURGH" FOLLOWED BY A PATTERN OF OFFSET PARALLELOGRAMS FOLLOWED BY THE WORDS "INTERNATIONAL RACECOMPLEX".

FOR ENTERTAINMENT IN THE NATURE OF PROVIDING FACILITIES FOR MOTORSPORTS (U.S. CLS. 100, 101 AND 107).

FIRST USE 12-8-2011; IN COMMERCE 12-8-2011.
DEIRDRE ROBERTSON, EXAMINING ATTORNEY

CLASS 41—(Continued).

SN 85-449,579. OXFORD GROUP INTERNATIONAL, LLC, FARMINGDALE, NY. FILED 10-18-2011.



THE MARK CONSISTS OF THE LETTERS GPA FOLLOWED BY THE NUMBER 5.0. A HORIZONTAL CRESCENT LIES ABOVE THE ENTIRE LITERAL ELEMENT OF THE MARK EXTENDING TO THE RIGHT OF THE ZERO IN 5.0.

FOR EDUCATIONAL SERVICES, NAMELY, SUPPLEMENTAL AND/OR REMEDIAL EDUCATION SERVICES, NAMELY, PERSONAL COACHING IN THE FIELD OF COGNITIVE SKILLS TO FACILITATE ACADEMIC GROWTH THROUGH INTERACTIVE COACHING; TUTORING OF STUDENTS ON ALL SUBJECTS TO ENHANCE AND DEVELOP ACADEMIC SKILLS; CONDUCTING COURSES OF INSTRUCTION AND LEARNING ENHANCEMENT THROUGH THE DEVELOPMENT OF CRITICAL THINKING, PROBLEM SOLVING AND GENERALIZATION COGNITIVE SKILLS (U.S. CLS. 100, 101 AND 107).

KATHERINE CONNOLLY, EXAMINING ATTORNEY

SN 85-449,605. ARTIFACT STUDIO, LLC, SAN FRANCISCO, CA. FILED 10-18-2011.

ARTIFACT

THE MARK CONSISTS OF STANDARD CHARACTERS WITHOUT CLAIM TO ANY PARTICULAR FONT, STYLE, SIZE, OR COLOR.

FOR EDUCATIONAL SERVICES, NAMELY, CONDUCTING CLASSES IN THE FIELD OF CHILDREN'S ART (U.S. CLS. 100, 101 AND 107).

FIRST USE 9-13-2010; IN COMMERCE 9-13-2010.
INGA ERVIN, EXAMINING ATTORNEY

SN 85-449,649. 3DBC, LLC, BROOKLYN, NY. FILED 10-18-2011.

BMS System

THE MARK CONSISTS OF STANDARD CHARACTERS WITHOUT CLAIM TO ANY PARTICULAR FONT, STYLE, SIZE, OR COLOR.

FOR EDUCATIONAL SERVICES, NAMELY, PROVIDING WORKSHOPS AND TRAINING TO TEACH WOMEN HOW TO OWN THEIR OWN UNIQUE BEAUTY (U.S. CLS. 100, 101 AND 107).

FIRST USE 4-9-2011; IN COMMERCE 4-9-2011.
LINDA MICKLEBURGH, EXAMINING ATTORNEY

CLASS 41—(Continued).

SN 85-449,656. OMP, INC., LONG BEACH, CA. FILED 10-18-2011.

NU-DERM

THE MARK CONSISTS OF STANDARD CHARACTERS WITHOUT CLAIM TO ANY PARTICULAR FONT, STYLE, SIZE, OR COLOR.
OWNER OF U.S. REG. NO. 2,155,067.
FOR TRAINING SERVICES IN THE FIELD OF SKIN CARE (U.S. CLS. 100, 101 AND 107).
HANNO RITTNER, EXAMINING ATTORNEY

CLASS 41—(Continued).

SN 85-449,797. CATHOLIC HEALTHCARE WEST, SAN FRANCISCO, CA. FILED 10-18-2011.

Brainbook

THE MARK CONSISTS OF STANDARD CHARACTERS WITHOUT CLAIM TO ANY PARTICULAR FONT, STYLE, SIZE, OR COLOR.
FOR EDUCATIONAL SERVICES, NAMELY, PROVIDING ON-LINE CLASSES IN THE FIELD OF CONCUSSION SIGNS AND DANGERS (U.S. CLS. 100, 101 AND 107).
B. PARADEWELAI, EXAMINING ATTORNEY

SN 85-449,672. BLAKE, TREVOR G., REDMOND, WA. FILED 10-18-2011.

Three Simple Steps

THE MARK CONSISTS OF STANDARD CHARACTERS WITHOUT CLAIM TO ANY PARTICULAR FONT, STYLE, SIZE, OR COLOR.
FOR PROFESSIONAL COACHING SERVICES IN THE FIELD OF PERSONAL GROWTH (U.S. CLS. 100, 101 AND 107).
COURTNEY ALVAREZ, EXAMINING ATTORNEY

SN 85-449,826. KATHLEEN A. HALL, CLARKESVILLE, GA. FILED 10-18-2011.

MINDFUL MOMENTS

SN 85-449,754. DEMATHA CATHOLIC HIGH SCHOOL, INC., HYATTSVILLE, MD. FILED 10-18-2011.

DEMATHA

THE MARK CONSISTS OF STANDARD CHARACTERS WITHOUT CLAIM TO ANY PARTICULAR FONT, STYLE, SIZE, OR COLOR.
FOR EDUCATIONAL SERVICES IN THE NATURE OF SECONDARY SCHOOLS (U.S. CLS. 100, 101 AND 107).
FIRST USE 9-9-1946; IN COMMERCE 9-9-1946.
DOMINIC J. FERRAIUOLO, EXAMINING ATTORNEY

THE MARK CONSISTS OF STANDARD CHARACTERS WITHOUT CLAIM TO ANY PARTICULAR FONT, STYLE, SIZE, OR COLOR.
OWNER OF U.S. REG. NOS. 3,440,450, 3,674,696 AND 3,720,241.
FOR ENTERTAINMENT SERVICES, NAMELY, AN ONGOING SERIES FEATURING PHYSICAL, MENTAL AND SPIRITUAL HEALTH, HEALING AND WELLNESS, LIFESTYLE MANAGEMENT, DISEASE PREVENTION, AND IDENTIFYING, OVERCOMING AND AVOIDING STRESS AND DESTRUCTIVE BEHAVIOR PROVIDED THROUGH THE INTERNET (U.S. CLS. 100, 101 AND 107).
FIRST USE 9-15-2010; IN COMMERCE 9-15-2010.
SALLY SHIH, EXAMINING ATTORNEY

CLASS 41—(Continued).

SN 85-449,894. KATHLEEN A. HALL, CLARKESVILLE, GA. FILED 10-18-2011.

MINDFUL FAMILY

THE MARK CONSISTS OF STANDARD CHARACTERS WITHOUT CLAIM TO ANY PARTICULAR FONT, STYLE, SIZE, OR COLOR.

OWNER OF U.S. REG. NOS. 3,877,397, 4,060,334 AND OTHERS.

NO CLAIM IS MADE TO THE EXCLUSIVE RIGHT TO USE "FAMILY", APART FROM THE MARK AS SHOWN.

FOR ENTERTAINMENT SERVICES, NAMELY, AN ONGOING SERIES FEATURING PHYSICAL, MENTAL AND SPIRITUAL HEALTH, HEALING AND WELLNESS, LIFESTYLE MANAGEMENT, DISEASE PREVENTION, AND IDENTIFYING, OVERCOMING AND AVOIDING STRESS AND DESTRUCTIVE BEHAVIOR PROVIDED THROUGH THE INTERNET (U.S. CLS. 100, 101 AND 107).

FIRST USE 9-15-2010; IN COMMERCE 9-15-2010.
SALLY SHIH, EXAMINING ATTORNEY

SN 85-449,928. JOWY PRODUCTIONS, BEVERLY HILLS, CA. FILED 10-18-2011.

WE PLAN. YOU PARTY.

THE MARK CONSISTS OF STANDARD CHARACTERS WITHOUT CLAIM TO ANY PARTICULAR FONT, STYLE, SIZE, OR COLOR.

FOR SPECIAL EVENT PLANNING FOR SOCIAL ENTERTAINMENT PURPOSES (U.S. CLS. 100, 101 AND 107).

FIRST USE 12-30-2010; IN COMMERCE 12-30-2010.
TEJBIR SINGH, EXAMINING ATTORNEY

SN 85-450,034. CONTRERAS, CARLA, M, BROOKLYN, NY. FILED 10-18-2011.

RED CLOG KITCHEN

THE MARK CONSISTS OF STANDARD CHARACTERS WITHOUT CLAIM TO ANY PARTICULAR FONT, STYLE, SIZE, OR COLOR.

NO CLAIM IS MADE TO THE EXCLUSIVE RIGHT TO USE "KITCHEN", APART FROM THE MARK AS SHOWN.

FOR EDUCATION SERVICES, NAMELY, PROVIDING LIVE AND ON-LINE WORKSHOPS, EDUCATIONAL DEMONSTRATIONS AND SEMINARS IN THE FIELD OF COOKING AND DISTRIBUTION OF COURSE MATERIALS IN CONNECTION THEREWITH; BLOGS FEATURING INFORMATION ON COOKING (U.S. CLS. 100, 101 AND 107).

FIRST USE 6-1-2011; IN COMMERCE 6-1-2011.
ALLISON HOLTZ, EXAMINING ATTORNEY

CLASS 41—(Continued).

SN 85-450,035. PARKER, MELVIN, HOUSTON, TX. FILED 10-18-2011.

PHASE II PHOTOGRAPHY

THE MARK CONSISTS OF STANDARD CHARACTERS WITHOUT CLAIM TO ANY PARTICULAR FONT, STYLE, SIZE, OR COLOR.

NO CLAIM IS MADE TO THE EXCLUSIVE RIGHT TO USE "PHOTOGRAPHY", APART FROM THE MARK AS SHOWN.

FOR PHOTOGRAPHY; PHOTOGRAPHY SERVICES; PORTRAIT PHOTOGRAPHY (U.S. CLS. 100, 101 AND 107).

FIRST USE 3-28-2011; IN COMMERCE 3-28-2011.
JESSICA A. POWERS, EXAMINING ATTORNEY

SN 85-450,141. ROGER ASMAR, NEW YORK, NY. FILED 10-18-2011.

Bring Rock Back

THE MARK CONSISTS OF STANDARD CHARACTERS WITHOUT CLAIM TO ANY PARTICULAR FONT, STYLE, SIZE, OR COLOR.

FOR PRODUCTION OF LIVE ENTERTAINMENT EVENTS, NAMELY, LIVE MUSICAL CONCERTS AND MUSIC FESTIVALS (U.S. CLS. 100, 101 AND 107).

FIRST USE 9-15-2011; IN COMMERCE 9-15-2011.
JOHN GARTNER, EXAMINING ATTORNEY

SN 85-450,167. BIOLOGICAL SCIENCES CURRICULUM STUDY, AKA BSCS, COLORADO SPRINGS, CO. FILED 10-18-2011.

5E

THE MARK CONSISTS OF STANDARD CHARACTERS WITHOUT CLAIM TO ANY PARTICULAR FONT, STYLE, SIZE, OR COLOR.

FOR EDUCATION SERVICES, NAMELY, PROVISION OF AN INSTRUCTIONAL MODEL TO EDUCATORS TO TEACH SCIENCES THROUGH APPLICATION OF A LEARNING MODEL AND TEACHING METHODOLOGY AND PROVIDING CURRICULA IN CONNECTION THEREWITH (U.S. CLS. 100, 101 AND 107).

FIRST USE 1-1-1989; IN COMMERCE 1-1-1989.
JACQUELINE A. LAVINE, EXAMINING ATTORNEY

CLASS 41—(Continued).

SN 85-450,177. RICHMOND CREATIVE GROUP, LLC, WINDHAM, ME. FILED 10-18-2011.

TO INSPIRE THE WORLD'S IMAGINATION

THE MARK CONSISTS OF STANDARD CHARACTERS WITHOUT CLAIM TO ANY PARTICULAR FONT, STYLE, SIZE, OR COLOR.

FOR AMUSEMENT PARK AND THEME PARK SERVICES; AMUSEMENT PARKS; ENTERTAINMENT SERVICES, NAMELY, ARRANGING AND CONDUCTING SPECIAL EVENTS AT AN AMUSEMENT PARK; PROVIDING THEME PARK SERVICES; RECREATIONAL PARK SERVICES (U.S. CLS. 100, 101 AND 107).

JASON BLAIR, EXAMINING ATTORNEY

SN 85-450,239. EDUCATION CONTINUUM, LLC, AND-OVER, MN. FILED 10-18-2011.

Higher Plain Learning

THE MARK CONSISTS OF STANDARD CHARACTERS WITHOUT CLAIM TO ANY PARTICULAR FONT, STYLE, SIZE, OR COLOR.

NO CLAIM IS MADE TO THE EXCLUSIVE RIGHT TO USE "LEARNING", APART FROM THE MARK AS SHOWN.

FOR EDUCATIONAL SERVICES, NAMELY, PROVIDING CONTINUING PROFESSIONAL EDUCATION COURSES IN THE FIELD OF TEACHER EDUCATION (U.S. CLS. 100, 101 AND 107).

SALLY SHIH, EXAMINING ATTORNEY

SN 85-450,300. VATTEROTT EDUCATIONAL CENTERS, INC., AKA EX'TREME INSTITUTE - BY NELLY, OLIVETTE, MO. FILED 10-18-2011.

How to Make a Beat

THE MARK CONSISTS OF STANDARD CHARACTERS WITHOUT CLAIM TO ANY PARTICULAR FONT, STYLE, SIZE, OR COLOR.

FOR EDUCATIONAL SERVICES, NAMELY, CONDUCTING CLASSES AND PROVIDING POSTSECONDARY EDUCATION IN THE FIELD OF SOUND ENGINEERING AND MUSIC PRODUCTION AND DISTRIBUTION OF EDUCATIONAL MATERIALS IN CONNECTION THEREWITH (U.S. CLS. 100, 101 AND 107).

JILL C. ALT, EXAMINING ATTORNEY

CLASS 41—(Continued).

SN 85-450,356. HOMETOWN HEROES BOXING, SOUTH CHARLESTON, WV. FILED 10-18-2011.

Hometown Heroes Boxing

THE MARK CONSISTS OF STANDARD CHARACTERS WITHOUT CLAIM TO ANY PARTICULAR FONT, STYLE, SIZE, OR COLOR.

NO CLAIM IS MADE TO THE EXCLUSIVE RIGHT TO USE "BOXING", APART FROM THE MARK AS SHOWN.

FOR EDUCATION SERVICES, NAMELY, MENTORING IN THE FIELD OF BOXING; EDUCATION SERVICES, NAMELY, PROVIDING CLASSES IN THE FIELD OF BOXING; ENTERTAINMENT IN THE NATURE OF BOXING CONTESTS; ORGANIZATION OF BOXING MATCHES; TEACHING IN THE FIELD OF BOXING (U.S. CLS. 100, 101 AND 107).

ALEXANDER L. POWERS, EXAMINING ATTORNEY

SN 85-450,389. X2LINE.COM LLC, MARIETTA, GA. FILED 10-18-2011.

Café Street

THE MARK CONSISTS OF STANDARD CHARACTERS WITHOUT CLAIM TO ANY PARTICULAR FONT, STYLE, SIZE, OR COLOR.

FOR ENTERTAINMENT SERVICES, NAMELY, PROVIDING ON-LINE COMPUTER GAMES (U.S. CLS. 100, 101 AND 107).

FIRST USE 10-16-2011; IN COMMERCE 10-16-2011.

ELI HELLMAN, EXAMINING ATTORNEY

SN 85-450,425. CELEBRATE EXPO, LLC, FOUNTAIN VALLEY, CA. FILED 10-18-2011.

CelebrateXpo!

THE MARK CONSISTS OF THE STYLIZED TEXT "CELEBRATEXPO!".

FOR EDUCATIONAL SERVICES, NAMELY, PROVIDING SEMINARS IN THE FIELD OF DESIGN (U.S. CLS. 100, 101 AND 107).

FIRST USE 9-18-2010; IN COMMERCE 1-1-2011.

ASMAT KHAN, EXAMINING ATTORNEY

CLASS 41—(Continued).

SN 85-450,554. CREATIVE TRANSFORMATIONS WELLNESS PROGRAM, LLC, LARGO, MD. FILED 10-19-2011.

JUST OBSERVE YOURSELF

THE MARK CONSISTS OF STANDARD CHARACTERS WITHOUT CLAIM TO ANY PARTICULAR FONT, STYLE, SIZE, OR COLOR.

FOR MEDITATION TRAINING (U.S. CLS. 100, 101 AND 107).

FIRST USE 10-16-2011; IN COMMERCE 10-16-2011.

JANICE L. MCMORROW, EXAMINING ATTORNEY

SN 85-451,420. KIM, STEVEN, UPLAND, CA. FILED 10-19-2011.

mind your bliss

THE MARK CONSISTS OF STANDARD CHARACTERS WITHOUT CLAIM TO ANY PARTICULAR FONT, STYLE, SIZE, OR COLOR.

FOR PEER TO PEER COACHING SERVICES IN THE FIELD OF MINDFUL LISTENING AND QUESTIONING SKILLS (U.S. CLS. 100, 101 AND 107).

FIRST USE 2-11-2011; IN COMMERCE 2-11-2011.

NAPOLEON SHARMA, EXAMINING ATTORNEY

SN 85-451,473. PALMS, MICHAEL CHARLES, BROOKLYN, NY. FILED 10-19-2011.

Chances With Wolves

THE MARK CONSISTS OF STANDARD CHARACTERS WITHOUT CLAIM TO ANY PARTICULAR FONT, STYLE, SIZE, OR COLOR.

FOR ENTERTAINMENT IN THE NATURE OF LIVE PERFORMANCES BY A MUSICAL GROUP; ENTERTAINMENT SERVICES, NAMELY, PROVIDING AN ON-GOING RADIO PROGRAM IN THE FIELD OF MUSIC; ENTERTAINMENT SERVICES, NAMELY, THE PROVISION OF CONTINUING MUSICAL VARIETY SHOWS FEATURING COMMENTARY DELIVERED BY RADIO (U.S. CLS. 100, 101 AND 107).

FIRST USE 7-20-2009; IN COMMERCE 7-20-2009.

REBECCA POVARCHUK, EXAMINING ATTORNEY

CLASS 41—(Continued).

SN 85-451,554. FIFTH STREET GAMING, LLC, LAS VEGAS, NV. FILED 10-19-2011.

DOWNTOWN GRAND

THE MARK CONSISTS OF STANDARD CHARACTERS WITHOUT CLAIM TO ANY PARTICULAR FONT, STYLE, SIZE, OR COLOR.

FOR AMUSEMENT ARCADES; ARRANGING AND CONDUCTING ATHLETIC COMPETITIONS; CASINOS; CONDUCTING AND PROVIDING FACILITIES FOR SPECIAL EVENTS FEATURING CASINO AND GAMING CONTESTS AND TOURNAMENTS; HEALTH CLUB SERVICES, NAMELY, PROVIDING INSTRUCTION AND EQUIPMENT IN THE FIELD OF PHYSICAL EXERCISE; NIGHT CLUBS; PROVIDING CASINO SERVICES FEATURING A CASINO PLAYERS REWARDS PROGRAM; PROVIDING FACILITIES FOR RECREATION ACTIVITIES; PROVIDING SWIMMING POOLS; SPECIAL EVENT PLANNING FOR SOCIAL ENTERTAINMENT PURPOSES; TICKET RESERVATION AND BOOKING SERVICES FOR ENTERTAINMENT, SPORTING AND CULTURAL EVENTS (U.S. CLS. 100, 101 AND 107).

DAVID HOFFMAN, EXAMINING ATTORNEY

SN 85-451,603. ECHO MINE LLC, WILTON, CT. FILED 10-19-2011.

ENDUROO

THE MARK CONSISTS OF STANDARD CHARACTERS WITHOUT CLAIM TO ANY PARTICULAR FONT, STYLE, SIZE, OR COLOR.

FOR ENTERTAINMENT SERVICES, NAMELY, PROVIDING AN ON-LINE COMPUTER GAME (U.S. CLS. 100, 101 AND 107).

SANJEEV VOHRA, EXAMINING ATTORNEY

CLASS 41—(Continued).

SN 85-452,119. SAN ANTONIO BOWL ASSOCIATION, SAN ANTONIO, TX. FILED 10-20-2011.

**YOU NEVER FORGET THE
FEELING**

THE MARK CONSISTS OF STANDARD CHARACTERS WITHOUT CLAIM TO ANY PARTICULAR FONT, STYLE, SIZE, OR COLOR.

FOR ENTERTAINMENT SERVICES, NAMELY, ORGANIZING AND CONDUCTING AN ANNUAL POST-SEASON COLLEGIATE FOOTBALL GAME AND COMMUNITY FESTIVAL FEATURING PRIMARILY A FOOTBALL CLINIC, PARTIES, GOLF TOURNAMENT, PEP RALLIES AND PROVIDING RECOGNITION AND INCENTIVES BY THE WAY OF AWARDS TO DEMONSTRATE EXCELLENCE IN THE FIELD OF ACADEMICS AND ALSO PROVIDING DINNER (U.S. CLS. 100, 101 AND 107).

FIRST USE 10-1-2011; IN COMMERCE 10-1-2011.
ROBERT C. CLARK JR., EXAMINING ATTORNEY

SN 85-452,374. MURPHY, KEVIN L., LOS ANGELES, CA. AND GRAD, JACQUELINE S., LOS ANGELES, CA. FILED 10-20-2011.

BEDROCK

THE MARK CONSISTS OF STANDARD CHARACTERS WITHOUT CLAIM TO ANY PARTICULAR FONT, STYLE, SIZE, OR COLOR.

FOR RECORDING STUDIOS (U.S. CLS. 100, 101 AND 107).

FIRST USE 8-1-2008; IN COMMERCE 1-15-2009.
JOHN DALIER, EXAMINING ATTORNEY

SN 85-453,405. REALAGE, INC., NEW YORK, NY. FILED 10-21-2011.

REALAGE

THE MARK CONSISTS OF STANDARD CHARACTERS WITHOUT CLAIM TO ANY PARTICULAR FONT, STYLE, SIZE, OR COLOR.

OWNER OF U.S. REG. NOS. 2,155,113, 3,216,403 AND OTHERS.

FOR PRODUCTION OF RADIO AND TELEVISION PROGRAMS (U.S. CLS. 100, 101 AND 107).

MARK T. MULLEN, EXAMINING ATTORNEY

CLASS 41—(Continued).

SN 85-453,956. RICHMOND CREATIVE GROUP, LLC, WINDHAM, ME. FILED 10-23-2011.

**WHERE HISTORY NOT ONLY
COMES ALIVE, YOU LIVE IT!**

THE MARK CONSISTS OF STANDARD CHARACTERS WITHOUT CLAIM TO ANY PARTICULAR FONT, STYLE, SIZE, OR COLOR.

FOR AMUSEMENT PARK AND THEME PARK SERVICES; AMUSEMENT PARKS; ENTERTAINMENT SERVICES, NAMELY, ARRANGING AND CONDUCTING SPECIAL EVENTS AT AN AMUSEMENT PARK; PROVIDING THEME PARK SERVICES; RECREATIONAL PARK SERVICES (U.S. CLS. 100, 101 AND 107).

JASON BLAIR, EXAMINING ATTORNEY

SN 85-454,231. HUMINTELL, LLC, EL CERRITO, CA. FILED 10-24-2011.

INTELLICULTURE

THE MARK CONSISTS OF STANDARD CHARACTERS WITHOUT CLAIM TO ANY PARTICULAR FONT, STYLE, SIZE, OR COLOR.

FOR EDUCATIONAL SERVICES, NAMELY, PROVIDING TRAINING IN THE FORM OF COURSES, SEMINARS AND WORKSHOPS IN THE FIELD OF CROSS-CULTURAL ADAPTATION; EDUCATION SERVICES, NAMELY, PROVIDING ON-LINE TRAINING IN THE FORM OF COURSES, SEMINARS AND WORKSHOPS IN THE FIELD OF CROSS-CULTURAL ADAPTATION (U.S. CLS. 100, 101 AND 107).

STEVEN JACKSON, EXAMINING ATTORNEY

SN 85-454,742. VICTORIA'S SECRET STORES BRAND MANAGEMENT, INC., REYNOLDSBURG, OH. FILED 10-24-2011.

**THE SEXIEST NIGHT ON
TELEVISION**

THE MARK CONSISTS OF STANDARD CHARACTERS WITHOUT CLAIM TO ANY PARTICULAR FONT, STYLE, SIZE, OR COLOR.

FOR ENTERTAINMENT, NAMELY, PRODUCTION OF ON-GOING FASHION SHOWS SHOWN ON TELEVISION (U.S. CLS. 100, 101 AND 107).

MICHAEL LITZAU, EXAMINING ATTORNEY

CLASS 41—(Continued).

SN 85-455,422. VIACOM INTERNATIONAL INC., NEW YORK, NY. FILED 10-25-2011.

WAKE BROTHERS

THE MARK CONSISTS OF STANDARD CHARACTERS WITHOUT CLAIM TO ANY PARTICULAR FONT, STYLE, SIZE, OR COLOR.

NO CLAIM IS MADE TO THE EXCLUSIVE RIGHT TO USE "BROTHERS", APART FROM THE MARK AS SHOWN.

FOR ENTERTAINMENT SERVICES IN THE NATURE OF CONTINUING PROGRAM SERIES, FEATURING LIVE ACTION, COMEDY AND DRAMA PROVIDED THROUGH CABLE TELEVISION, BROADCAST TELEVISION, INTERNET, VIDEO-ON-DEMAND, AND THROUGH OTHER DISTRIBUTION PLATFORMS; PROVIDING ONLINE INFORMATION IN THE FIELD OF ENTERTAINMENT CONCERNING TELEVISION PROGRAMS (U.S. CLS. 100, 101 AND 107).

ALEX KEAM, EXAMINING ATTORNEY

CLASS 41—(Continued).

SN 85-456,700. TELEVISA, S.A. DE C.V., SANTA FE, MEXICO, FILED 10-26-2011.

GLITTER CAFÉ

THE MARK CONSISTS OF STANDARD CHARACTERS WITHOUT CLAIM TO ANY PARTICULAR FONT, STYLE, SIZE, OR COLOR.

OWNER OF MEXICO REG. NO. 1213989, DATED 12-7-2010, EXPIRES 12-7-2020.

FOR ENTERTAINMENT SERVICES IN THE NATURE OF A CONTINUING SHOW BROADCAST OVER THE INTERNET FEATURING INFORMATION REGARDING TENDENCIES FOR LIFE STYLE, FASHION, TECHNOLOGICAL GADGETS, MUSIC, INTERVIEWS WITH ARTISTS AND AN ONGOING TV PROGRAM FEATURING INFORMATION REGARDING TENDENCIES FOR LIFE STYLE, FASHION, TECHNOLOGICAL GADGETS, MUSIC, INTERVIEWS WITH ARTISTS (U.S. CLS. 100, 101 AND 107).

GILBERT SWIFT, EXAMINING ATTORNEY

SN 85-455,602. PHICOM INVESTMENTS, INC, TEXARKANA, TX. FILED 10-25-2011.

DIP P. DOO

THE MARK CONSISTS OF STANDARD CHARACTERS WITHOUT CLAIM TO ANY PARTICULAR FONT, STYLE, SIZE, OR COLOR.

THE NAME(S), PORTRAIT(S), AND/OR SIGNATURE(S) SHOWN IN THE MARK DOES NOT IDENTIFY A PARTICULAR LIVING INDIVIDUAL.

FOR ENTERTAINMENT AND AMUSEMENT CENTERS FEATURING BUMPER-CARS, ARCADE GAMES, GO-KARTS AND MOVIE THEATERS (U.S. CLS. 100, 101 AND 107).

AISHA SALEM, EXAMINING ATTORNEY

SN 85-456,782. TELEVISA, S.A. DE C.V., SANTA FE, MEXICO, FILED 10-26-2011.

FURCIO

THE MARK CONSISTS OF STANDARD CHARACTERS WITHOUT CLAIM TO ANY PARTICULAR FONT, STYLE, SIZE, OR COLOR.

FOR ENTERTAINMENT SERVICES IN THE NATURE OF AN ONGOING COMEDY SHOW FEATURING SHORT OUT-TAKES BROADCAST OVER THE INTERNET AND AN ONGOING TV PROGRAM IN THE FIELD OF COMEDY FEATURING SHORT OUT-TAKES (U.S. CLS. 100, 101 AND 107).

FIRST USE 11-12-2011; IN COMMERCE 11-12-2011.

GILBERT SWIFT, EXAMINING ATTORNEY

CLASS 41—(Continued).

SN 85-456,945. NATIONAL CINEMEDIA, LLC, CENTENNIAL, CO. FILED 10-26-2011.

MOVIE NIGHT OUT

THE MARK CONSISTS OF STANDARD CHARACTERS WITHOUT CLAIM TO ANY PARTICULAR FONT, STYLE, SIZE, OR COLOR.

OWNER OF U.S. REG. NO. 4,051,772.

NO CLAIM IS MADE TO THE EXCLUSIVE RIGHT TO USE "MOVIE", APART FROM THE MARK AS SHOWN.

FOR PROVIDING INFORMATION, NEWS AND COMMENTARY IN THE FIELD OF ENTERTAINMENT, NAMELY, MOVIES AND CELEBRITIES; ENTERTAINMENT SERVICES IN THE FIELD OF FILM, MOVIES AND ENTERTAINMENT, NAMELY, PRODUCTION, EDITING AND DISTRIBUTION OF FILM CLIPS, MOVIE TRAILERS, NEWS ARTICLES, PHOTOGRAPHS AND OTHER MULTIMEDIA MATERIALS; ENTERTAINMENT SERVICES IN THE NATURE OF DEVELOPMENT, CREATION, PRODUCTION AND POST-PRODUCTION SERVICES OF MULTIMEDIA ENTERTAINMENT CONTENT; PROVIDING WEBSITES AND MOBILE MEDIA CONTENT IN THE NATURE OF NON-DOWNLOADABLE PHOTOGRAPHIC, AUDIO AND VIDEO PRESENTATIONS AND NON-DOWNLOADABLE VIDEOS FEATURING ENTERTAINMENT INFORMATION; ENTERTAINMENT SERVICES, NAMELY, PROVIDING WEBSITES AND MOBILE MEDIA CONTENT IN THE NATURE OF NON-DOWNLOADABLE PHOTOGRAPHIC, AUDIO AND VIDEO PRESENTATIONS AND NON-DOWNLOADABLE VIDEOS FEATURING NON-DOWNLOADABLE FILM CLIPS, MOVIE TRAILERS, PHOTOGRAPHS, MUSIC AND MULTIMEDIA MATERIALS ALL IN THE FIELD OF ENTERTAINMENT; PROVIDING INTERNET WEBSITES IN THE FIELD OF MOVIES AND ENTERTAINMENT; PROVIDING WEBSITES FEATURING ENTERTAINMENT INFORMATION; ENTERTAINMENT SERVICES, NAMELY, PROVIDING ON-LINE REVIEWS, RATINGS AND RECOMMENDATIONS FOR MOVIES AND FILMS; PROVIDING ON-LINE INFORMATION IN THE FIELD ENTERTAINMENT VIA THE INTERNET AND MOBILE COMMUNICATION DEVICES; MOVIE THEATER AND MOVIE SCHEDULE AND LOCATION INFORMATION SERVICES (U.S. CLS. 100, 101 AND 107).

FIRST USE 4-13-2010; IN COMMERCE 9-7-2010.

WILLIAM VERHOSEK, EXAMINING ATTORNEY

CLASS 41—(Continued).

SN 85-457,011. VIACOM INTERNATIONAL INC., NEW YORK, NY. FILED 10-26-2011.

STEVIE TV

THE MARK CONSISTS OF STANDARD CHARACTERS WITHOUT CLAIM TO ANY PARTICULAR FONT, STYLE, SIZE, OR COLOR.

NO CLAIM IS MADE TO THE EXCLUSIVE RIGHT TO USE "TV", APART FROM THE MARK AS SHOWN.

FOR ENTERTAINMENT SERVICES IN THE NATURE OF CONTINUING PROGRAM SERIES, FEATURING LIVE ACTION, COMEDY AND DRAMA PROVIDED THROUGH CABLE TELEVISION, BROADCAST TELEVISION, INTERNET, VIDEO-ON-DEMAND, AND THROUGH OTHER DISTRIBUTION PLATFORMS; PROVIDING ONLINE INFORMATION IN THE FIELD OF ENTERTAINMENT CONCERNING TELEVISION PROGRAMS (U.S. CLS. 100, 101 AND 107).

ALEX KEAM, EXAMINING ATTORNEY

SN 85-457,712. CONWAY & FRATES, L.L.C., TULSA, OK. FILED 10-27-2011.

CENTRAL HIGH

THE MARK CONSISTS OF STANDARD CHARACTERS WITHOUT CLAIM TO ANY PARTICULAR FONT, STYLE, SIZE, OR COLOR.

OWNER OF U.S. REG. NO. 2,497,787.

FOR PROVIDING AN ONLINE INTERACTIVE GAME IN THE FORM OF A MOVIE WHERE CHARACTER DEVELOPMENT OF THE VIEWER PARTICIPANT IS EMPHASIZED (U.S. CLS. 100, 101 AND 107).

FIRST USE 2-28-2009; IN COMMERCE 2-28-2009.

WENDY JUN, EXAMINING ATTORNEY

SN 85-457,759. CONWAY & FRATES, L.L.C., TULSA, OK. FILED 10-27-2011.

DESTINY INTERACTIVE

THE MARK CONSISTS OF STANDARD CHARACTERS WITHOUT CLAIM TO ANY PARTICULAR FONT, STYLE, SIZE, OR COLOR.

OWNER OF U.S. REG. NO. 2,492,111.

NO CLAIM IS MADE TO THE EXCLUSIVE RIGHT TO USE "INTERACTIVE", APART FROM THE MARK AS SHOWN.

FOR PROVIDING AN ONLINE INTERACTIVE GAME IN THE FORM OF A MOVIE WHERE CHARACTER DEVELOPMENT OF THE VIEWER PARTICIPANT IS EMPHASIZED (U.S. CLS. 100, 101 AND 107).

FIRST USE 2-28-2009; IN COMMERCE 2-28-2009.

WENDY JUN, EXAMINING ATTORNEY

CLASS 41—(Continued).

SN 85-457,868. ARENA FOOTBALL ONE, LLC, DBA ARENA FOOTBALL LEAGUE, TULSA, OK. FILED 10-27-2011.



OWNER OF U.S. REG. NOS. 1,855,376 AND 3,954,765. NO CLAIM IS MADE TO THE EXCLUSIVE RIGHT TO USE "SEASONS", APART FROM THE MARK AS SHOWN.

THE COLOR(S) BLUE, RED, WHITE AND SILVER IS/ARE CLAIMED AS A FEATURE OF THE MARK.

THE MARK CONSISTS OF THE WORDING "25 SEASONS" IN BLUE. BETWEEN THE "25" NUMBERS IS THE WORDING "AFL" LINED IN SILVER WITH "A" IN RED AND "FL" IN BLUE. BELOW THIS WORDING IS A BLUE LINED SHIELD OUTLINED IN SILVER CONTAINING A FOOTBALL PLAYER IN BLUE AND OUTLINED IN SILVER. RED APPEARS AT THE BOTTOM OF THE SHIELD. THE INTERIOR OF THE SHIELD IS ALSO LINED IN SILVER AND A SILVER STREAK APPEARS BETWEEN THE RED SHIELD INTERIOR AND THE FOOTBALL PLAYER. A BLUE FOOTBALL APPEARS ON THE LEFT OF THE SHIELD. THE ENTIRE MARK IS OUTLINED IN SILVER. WHITE APPEARS WITHIN THE GRAY OUTER LINE AND THE WORDING "25 SEASONS" AND WITHIN THE SHIELD BEHIND THE FOOTBALL PLAYER.

FOR ENTERTAINMENT SERVICES, NAMELY, ORGANIZING AND PRESENTING FOOTBALL GAMES BEFORE LIVE AUDIENCES AND ON TELEVISION, RADIO, FOR GLOBAL COMPUTER NETWORK DISPLAY AND OTHER MEDIA (U.S. CLS. 100, 101 AND 107).

FIRST USE 8-12-2011; IN COMMERCE 8-12-2011.

REBECCA POVARCHUK, EXAMINING ATTORNEY

SN 85-458,390. LIPMAN, SUSAN SACHS, MILL VALLEY, CA. FILED 10-27-2011.

SLOW FAMILY

THE MARK CONSISTS OF STANDARD CHARACTERS WITHOUT CLAIM TO ANY PARTICULAR FONT, STYLE, SIZE, OR COLOR.

NO CLAIM IS MADE TO THE EXCLUSIVE RIGHT TO USE "FAMILY", APART FROM THE MARK AS SHOWN.

FOR EDUCATION SERVICES, NAMELY, PROVIDING SEMINARS, LECTURES, AND WORKSHOPS IN THE FIELD OF PARENTING, FAMILY AND LIFESTYLE.; ON-LINE JOURNALS, NAMELY, BLOGS FEATURING INFORMATION IN THE FIELDS OF PARENTING, FAMILY AND LIFESTYLE (U.S. CLS. 100, 101 AND 107).

TASNEEM HUSSAIN, EXAMINING ATTORNEY

CLASS 41—(Continued).

SN 85-458,643. VENTURE STUDIO, LLC, NEW YORK, NY. FILED 10-28-2011.

VENTURE STUDIO

THE MARK CONSISTS OF STANDARD CHARACTERS WITHOUT CLAIM TO ANY PARTICULAR FONT, STYLE, SIZE, OR COLOR.

NO CLAIM IS MADE TO THE EXCLUSIVE RIGHT TO USE "STUDIO", APART FROM THE MARK AS SHOWN.

FOR PROVIDING ONLINE INTERVIEWS FEATURING ENTREPRENEURS, INVESTORS, WRITERS AND PERSONALITIES IN THE FIELD OF ENTREPRENEURSHIP FOR ENTERTAINMENT PURPOSES (U.S. CLS. 100, 101 AND 107).

FIRST USE 2-28-2011; IN COMMERCE 2-28-2011.

ZACHARY BELLO, EXAMINING ATTORNEY

SN 85-458,667. FREEMAN, BRET, FARNHAM COMMON, UNITED KINGDOM, FILED 10-28-2011.

IT'S GO TIME

THE MARK CONSISTS OF STANDARD CHARACTERS WITHOUT CLAIM TO ANY PARTICULAR FONT, STYLE, SIZE, OR COLOR.

OWNER OF UNITED KINGDOM REG. NO. 2563114, DATED 11-3-2010, EXPIRES 11-3-2020.

FOR ENTERTAINMENT SERVICES, NAMELY, VOICE SERVICES FOR SPORTING EVENTS; ENTERTAINMENT SERVICES, NAMELY, ANNOUNCING SERVICES FOR RADIO, TELEVISION, FILM, MUSIC AND VIDEOS; ENTERTAINMENT SERVICES, NAMELY, PROVIDING CHARACTER VOICES FOR TAPES, RECORDS AND OTHER RECORDED MEDIA FOR ENTERTAINMENT AND EDUCATION PURPOSES; MASTER OF CEREMONY SERVICES (U.S. CLS. 100, 101 AND 107).

TEJBIR SINGH, EXAMINING ATTORNEY

CLASS 41—(Continued).

SN 85-460,205. TEN HATS PRODUCTIONS, LLC, WOODLAND HILLS, CA. FILED 10-31-2011.

**TEN HATS
PRODUCTIONS**

NO CLAIM IS MADE TO THE EXCLUSIVE RIGHT TO USE "PRODUCTIONS", APART FROM THE MARK AS SHOWN.

THE COLOR(S) BLACK, WHITE AND GRAY IS/ARE CLAIMED AS A FEATURE OF THE MARK.

THE MARK CONSISTS OF THE WORDS "TEN HATS" ARE WRITTEN ABOVE THE WORD "PRODUCTIONS" ALL IN BLACK TYPE; THE "H" IN "HATS" HAS BEEN STYLIZED TO INCLUDE A BLACK FEDORA HAT WITH WHITE TRIM AND GRAY SHADING.

FOR DISTRIBUTION OF MOTION PICTURE FILMS; PRODUCTION AND DISTRIBUTION OF MOTION PICTURES (U.S. CLS. 100, 101 AND 107).

FIRST USE 8-1-2011; IN COMMERCE 10-24-2011.

LOURDES AYALA, EXAMINING ATTORNEY

CLASS 41—(Continued).

SN 85-461,166. TELEVISA, S.A. DE C.V., SANTA FE, MEXICO, FILED 11-1-2011.

CUIDA TU SALUD

THE MARK CONSISTS OF STANDARD CHARACTERS WITHOUT CLAIM TO ANY PARTICULAR FONT, STYLE, SIZE, OR COLOR.

THE ENGLISH TRANSLATION OF "CUIDA TU SALUD" IN THE MARK IS "TAKE CARE OF YOUR HEALTH".

FOR ENTERTAINMENT SERVICES IN THE NATURE OF AN ONGOING SPANISH LANGUAGE SHOW BROADCAST OVER THE INTERNET REGARDING CURRENT NEWS AND INFORMATION ON HEALTH PROMOTION AND DISEASE PREVENTION, AND AN ONGOING SPANISH LANGUAGE TV PROGRAM REGARDING CURRENT NEWS AND INFORMATION ON HEALTH PROMOTION AND DISEASE PREVENTION (U.S. CLS. 100, 101 AND 107).

FIRST USE 11-13-2011; IN COMMERCE 11-13-2011.

GILBERT SWIFT, EXAMINING ATTORNEY

SN 85-461,390. THE INSTITUTE OF INTERNAL AUDITORS, INC., ALTAMONTE SPRINGS, FL. FILED 11-1-2011.

AUDIT CHANNEL

THE MARK CONSISTS OF STANDARD CHARACTERS WITHOUT CLAIM TO ANY PARTICULAR FONT, STYLE, SIZE, OR COLOR.

OWNER OF U.S. REG. NO. 2,928,371.

SEC. 2(F).

FOR EDUCATIONAL SERVICES, NAMELY, CONDUCTING COURSES, WORKSHOPS, SEMINARS AND WEBINARS OVER THE INTERNET AND OVER INTRANETS IN THE FIELD OF AUDITING; PROVIDING TRAINING COURSES FOR OTHERS VIA THE INTERNET AND INTRANETS IN THE FIELD OF AUDITING (U.S. CLS. 100, 101 AND 107).

FIRST USE 11-8-2004; IN COMMERCE 11-8-2004.

ALLISON SCHRODY, EXAMINING ATTORNEY

SN 85-460,476. WORLD WRESTLING ENTERTAINMENT, INC., STAMFORD, CT. FILED 10-31-2011.

WWE LIVEWIRE

THE MARK CONSISTS OF STANDARD CHARACTERS WITHOUT CLAIM TO ANY PARTICULAR FONT, STYLE, SIZE, OR COLOR.

OWNER OF U.S. REG. NOS. 2,772,683, 3,578,960 AND OTHERS.

FOR ENTERTAINMENT SERVICES, NAMELY, A TELEVISION SHOW ABOUT SPORTS ENTERTAINMENT; ENTERTAINMENT SERVICES, NAMELY, THE PRODUCTION AND EXHIBITION OF PROFESSIONAL WRESTLING EVENTS RENDERED LIVE AND THROUGH THE MEDIA OF TELEVISION; ENTERTAINMENT SERVICES, NAMELY, A TELEVISION SHOW ABOUT PROFESSIONAL WRESTLING; ENTERTAINMENT SERVICES, NAMELY, WRESTLING-RELATED ON-GOING REALITY BASED TELEVISION PROGRAM; PROVIDING WRESTLING NEWS AND INFORMATION VIA A GLOBAL COMPUTER NETWORK (U.S. CLS. 100, 101 AND 107).

ALEX KEAM, EXAMINING ATTORNEY

SN 85-465,294. HEWLETT-PACKARD DEVELOPMENT COMPANY, L.P., HOUSTON, TX. FILED 11-4-2011.

PWN20WN

THE MARK CONSISTS OF STANDARD CHARACTERS WITHOUT CLAIM TO ANY PARTICULAR FONT, STYLE, SIZE, OR COLOR.

FOR COMPUTER SECURITY CONTEST EVENT WHERE CONTESTANTS ARE CHALLENGED TO FIND SECURITY VULNERABILITIES IN COMPUTING PLATFORMS AND SOFTWARE (U.S. CLS. 100, 101 AND 107).

KELLY TRUSILO, EXAMINING ATTORNEY

CLASS 41—(Continued).

SN 85-474,482. SOURCE INTERLINK MAGAZINES, LLC, EL SEGUNDO, CA. FILED 11-16-2011.

MUD LIFE

THE MARK CONSISTS OF STANDARD CHARACTERS WITHOUT CLAIM TO ANY PARTICULAR FONT, STYLE, SIZE, OR COLOR.

OWNER OF U.S. REG. NO. 3,748,352.

NO CLAIM IS MADE TO THE EXCLUSIVE RIGHT TO USE "MUD", APART FROM THE MARK AS SHOWN.

FOR PROVIDING A WEBSITE FEATURING NON-DOWNLOADABLE PUBLICATIONS IN THE NATURE OF MAGAZINES IN THE FIELD OF MUD TRUCKS, MUD TRUCK COMPETITIONS, EXHIBITIONS, AND EVENTS FEATURING MUD TRUCKS, ALL-TERRAIN VEHICLES, AND OTHER OFF-ROAD VEHICLES (U.S. CLS. 100, 101 AND 107).

FIRST USE 8-0-2008; IN COMMERCE 8-0-2008.
FONG HSU, EXAMINING ATTORNEY

CLASS 41—(Continued).

SN 85-485,903. VIACOM INTERNATIONAL INC., NEW YORK, NY. FILED 12-2-2011.

LIQUID TELEVISION

THE MARK CONSISTS OF STANDARD CHARACTERS WITHOUT CLAIM TO ANY PARTICULAR FONT, STYLE, SIZE, OR COLOR.

NO CLAIM IS MADE TO THE EXCLUSIVE RIGHT TO USE "TELEVISION", APART FROM THE MARK AS SHOWN.

FOR ENTERTAINMENT SERVICES IN THE NATURE OF A REMAKE OF A CONTINUING PROGRAM SERIES FEATURING ANIMATION, LIVE ACTION, COMEDY AND DRAMA BASED ON THE FAMOUS MTV SERIES OF SAME NAME PROVIDED THROUGH CABLE TELEVISION, BROADCAST TELEVISION, INTERNET, VIDEO-ON-DEMAND, AND THROUGH OTHER DISTRIBUTION PLATFORMS; PROVIDING ONLINE INFORMATION IN THE FIELD OF ENTERTAINMENT CONCERNING TELEVISION PROGRAMS (U.S. CLS. 100, 101 AND 107).

ALEX KEAM, EXAMINING ATTORNEY

SN 85-485,907. VIACOM INTERNATIONAL INC., NEW YORK, NY. FILED 12-2-2011.

SN 85-476,715. SOURCE INTERLINK MAGAZINES, LLC, EL SEGUNDO, CA. FILED 11-18-2011.

GEEK LIFE

THE MARK CONSISTS OF STANDARD CHARACTERS WITHOUT CLAIM TO ANY PARTICULAR FONT, STYLE, SIZE, OR COLOR.

FOR PROVIDING ON-LINE NON-DOWNLOADABLE MAGAZINE FOCUSED ON TOPICS OF INTEREST TO ENTHUSIASTS OF ELECTRONICS, MOBILE AND NEW MEDIA, VIDEO GAMES, AND ANIME (U.S. CLS. 100, 101 AND 107).

FONG HSU, EXAMINING ATTORNEY

LIQUID TV

THE MARK CONSISTS OF STANDARD CHARACTERS WITHOUT CLAIM TO ANY PARTICULAR FONT, STYLE, SIZE, OR COLOR.

NO CLAIM IS MADE TO THE EXCLUSIVE RIGHT TO USE "TV", APART FROM THE MARK AS SHOWN.

FOR ENTERTAINMENT SERVICES IN THE NATURE OF A REMAKE OF A CONTINUING PROGRAM SERIES FEATURING ANIMATION, LIVE ACTION, COMEDY AND DRAMA BASED ON THE FAMOUS MTV SERIES OF SAME NAME PROVIDED THROUGH CABLE TELEVISION, BROADCAST TELEVISION, INTERNET, VIDEO-ON-DEMAND, AND THROUGH OTHER DISTRIBUTION PLATFORMS; PROVIDING ONLINE INFORMATION IN THE FIELD OF ENTERTAINMENT CONCERNING TELEVISION PROGRAMS (U.S. CLS. 100, 101 AND 107).

ALEX KEAM, EXAMINING ATTORNEY

CLASS 41—(Continued).

SN 85-486,282. TELEvisa, S.A. DE C.V., SANTA FE, MEXICO, FILED 12-2-2011.

NAVIDAD SIN FIN

THE MARK CONSISTS OF STANDARD CHARACTERS WITHOUT CLAIM TO ANY PARTICULAR FONT, STYLE, SIZE, OR COLOR.

OWNER OF MEXICO REG. NO. 875145, DATED 2-5-2005, EXPIRES 2-5-2015.

THE ENGLISH TRANSLATION OF "NAVIDAD SIN FIN" IN THE MARK IS "NEVER ENDING CHRISTMAS".

FOR ENTERTAINMENT SERVICES IN THE NATURE OF A CONTINUING DRAMATIC SHOW BROADCAST OVER THE INTERNET AND AN ONGOING DRAMATIC TELEVISION SHOW (U.S. CLS. 100, 101 AND 107).
GILBERT SWIFT, EXAMINING ATTORNEY

CLASS 41—(Continued).

SN 85-494,034. U.S. MARINE CORPS, A COMPONENT OF THE U.S. DEPARTMENT OF THE NAVY, WASHINGTON, DC. FILED 12-13-2011.

HEALTHY KIDS FUN RUN

THE MARK CONSISTS OF STANDARD CHARACTERS WITHOUT CLAIM TO ANY PARTICULAR FONT, STYLE, SIZE, OR COLOR.

NO CLAIM IS MADE TO THE EXCLUSIVE RIGHT TO USE "HEALTHY KIDS" AND "RUN", APART FROM THE MARK AS SHOWN.

FOR ORGANIZING, ARRANGING, AND CONDUCTING RUNNING AND ATHLETIC EVENTS; PROVIDING A WEBSITE FEATURING INFORMATION RELATING TO THE SPORT OF RUNNING AND FITNESS (U.S. CLS. 100, 101 AND 107).

FIRST USE 10-27-2001; IN COMMERCE 10-27-2001.

RAUL CORDOVA, EXAMINING ATTORNEY

SN 85-494,858. CABLE NEWS NETWORK, INC., ATLANTA, GA. FILED 12-14-2011.

UNDERScore

THE MARK CONSISTS OF STANDARD CHARACTERS WITHOUT CLAIM TO ANY PARTICULAR FONT, STYLE, SIZE, OR COLOR.

FOR ON-LINE JOURNALS, NAMELY, BLOGS FEATURING NEWS, ENTERTAINMENT, CURRENT EVENTS AND POLITICS (U.S. CLS. 100, 101 AND 107).

LINDA M. KING, EXAMINING ATTORNEY

SN 85-490,264. VIACOM INTERNATIONAL INC., NEW YORK, NY. FILED 12-8-2011.

STyled BY JUNE

THE MARK CONSISTS OF STANDARD CHARACTERS WITHOUT CLAIM TO ANY PARTICULAR FONT, STYLE, SIZE, OR COLOR.

NO CLAIM IS MADE TO THE EXCLUSIVE RIGHT TO USE "STyled", APART FROM THE MARK AS SHOWN.

FOR ENTERTAINMENT SERVICES IN THE NATURE OF CONTINUING PROGRAM SERIES, FEATURING LIVE ACTION, COMEDY AND DRAMA PROVIDED THROUGH CABLE TELEVISION, BROADCAST TELEVISION, INTERNET, VIDEO-ON-DEMAND, AND THROUGH OTHER DISTRIBUTION PLATFORMS; PROVIDING ONLINE INFORMATION IN THE FIELD OF ENTERTAINMENT CONCERNING TELEVISION PROGRAMS (U.S. CLS. 100, 101 AND 107).

ALEX KEAM, EXAMINING ATTORNEY

SN 85-499,049. NATIONAL CINEMEDIA, LLC, CENTENNIAL, CO. FILED 12-19-2011.

CINEMA SYNC

THE MARK CONSISTS OF STANDARD CHARACTERS WITHOUT CLAIM TO ANY PARTICULAR FONT, STYLE, SIZE, OR COLOR.

NO CLAIM IS MADE TO THE EXCLUSIVE RIGHT TO USE "CINEMA", APART FROM THE MARK AS SHOWN.

FOR PROVIDING INFORMATION, NEWS AND COMMENTARY IN THE FIELD OF ENTERTAINMENT; PROVIDING AN INTERNET WEBSITE IN THE FIELD OF MOVIES AND ENTERTAINMENT (U.S. CLS. 100, 101 AND 107).

FIRST USE 12-14-2011; IN COMMERCE 12-14-2011.

WILLIAM VERHOSEK, EXAMINING ATTORNEY

CLASS 41—(Continued).

SN 85-512,892. CABLE NEWS NETWORK, INC., ATLANTA, GA. FILED 1-10-2012.

MAGIC WALL

THE MARK CONSISTS OF STANDARD CHARACTERS WITHOUT CLAIM TO ANY PARTICULAR FONT, STYLE, SIZE, OR COLOR.

FOR ENTERTAINMENT SERVICES, NAMELY, PRODUCTION OF COMPUTER-GENERATED IMAGERY AND COMPUTER-GENERATED GRAPHICS FOR USE IN THE PRODUCTION OF TELEVISION AND INTERNET COVERAGE OF NEWS, ENTERTAINMENT, CURRENT EVENTS AND POLITICS (U.S. CLS. 100, 101 AND 107).

LINDA M. KING, EXAMINING ATTORNEY

SN 85-513,286. N-M VENTURES, LLC, LAS VEGAS, NV. FILED 1-10-2012.

FANCY SAUCE

THE MARK CONSISTS OF STANDARD CHARACTERS WITHOUT CLAIM TO ANY PARTICULAR FONT, STYLE, SIZE, OR COLOR.

FOR ARRANGING FOR TICKET RESERVATIONS FOR SHOWS AND OTHER ENTERTAINMENT EVENTS; DISC JOCKEY SERVICES; ENTERTAINMENT IN THE NATURE OF LIVE PERFORMANCES FEATURING MUSICIANS, DANCERS, ACTORS AND ACROBATS; NIGHTS-CLUBS; PROVIDING FACILITIES FOR PRODUCING VIDEO, CINEMA AND PHOTOGRAPHY PRODUCTIONS; PROVIDING FACILITIES FOR RECREATION ACTIVITIES; SPECIAL EVENT PLANNING FOR SOCIAL ENTERTAINMENT PURPOSES (U.S. CLS. 100, 101 AND 107).

BRENDAN MCCAULEY, EXAMINING ATTORNEY

CLASS 41—(Continued).

SN 85-515,961. KATHLEEN A. HALL, CLARKESVILLE, GA. FILED 1-13-2012.

RENEWAL RITUALS

THE MARK CONSISTS OF STANDARD CHARACTERS WITHOUT CLAIM TO ANY PARTICULAR FONT, STYLE, SIZE, OR COLOR.

OWNER OF U.S. REG. NOS. 3,873,949 AND 3,877,416. FOR ENTERTAINMENT SERVICES, NAMELY, AN ONGOING SERIES FEATURING PHYSICAL, MENTAL AND SPIRITUAL HEALTH, HEALING AND WELLNESS, LIFESTYLE MANAGEMENT, DISEASE PREVENTION, AND IDENTIFYING, OVERCOMING AND AVOIDING STRESS AND DESTRUCTIVE BEHAVIOR PROVIDED THROUGH THE INTERNET (U.S. CLS. 100, 101 AND 107).

FIRST USE 10-6-2010; IN COMMERCE 10-6-2010.
SALLY SHIH, EXAMINING ATTORNEY

SN 85-520,254. HYRO-GLIFF, NEW YORK, NY. FILED 1-19-2012.

EVERYONE PARTIES IN CABO

THE MARK CONSISTS OF STANDARD CHARACTERS WITHOUT CLAIM TO ANY PARTICULAR FONT, STYLE, SIZE, OR COLOR.

FOR NIGHT CLUBS (U.S. CLS. 100, 101 AND 107).
ANDREA K. NADELMAN, EXAMINING ATTORNEY

SN 85-526,503. FAIR HEALTH, INC., NEW YORK, NY. FILED 1-26-2012.

FAIR HEALTH ACCESS

THE MARK CONSISTS OF STANDARD CHARACTERS WITHOUT CLAIM TO ANY PARTICULAR FONT, STYLE, SIZE, OR COLOR.

OWNER OF U.S. REG. NOS. 4,039,068 AND 4,046,275. NO CLAIM IS MADE TO THE EXCLUSIVE RIGHT TO USE "HEALTH", APART FROM THE MARK AS SHOWN. FOR ON-LINE ELECTRONIC NEWSLETTERS IN THE FIELD OF HEALTH CARE EXPENSES (U.S. CLS. 100, 101 AND 107).

FIRST USE 9-21-2011; IN COMMERCE 9-21-2011.
ALEXANDER L. POWERS, EXAMINING ATTORNEY

CLASS 41—(Continued).

SN 85-526,525. FAIR HEALTH, INC., NEW YORK, NY. FILED 1-26-2012.

FAIR HEALTH CONSUMER ACCESS

THE MARK CONSISTS OF STANDARD CHARACTERS WITHOUT CLAIM TO ANY PARTICULAR FONT, STYLE, SIZE, OR COLOR.

OWNER OF U.S. REG. NOS. 4,039,068 AND 4,046,275. NO CLAIM IS MADE TO THE EXCLUSIVE RIGHT TO USE "HEALTH CONSUMER", APART FROM THE MARK AS SHOWN.

FOR ON-LINE ELECTRONIC NEWSLETTERS IN THE FIELD OF HEALTH CARE EXPENSES (U.S. CLS. 100, 101 AND 107).

FIRST USE 10-10-2011; IN COMMERCE 10-10-2011. ALEXANDER L. POWERS, EXAMINING ATTORNEY

CLASS 42—(Continued).

SN 85-004,215. GEOSYNTEC CONSULTANTS, INC., BOCA RATON, FL. FILED 4-1-2010.

MMI

THE MARK CONSISTS OF STANDARD CHARACTERS WITHOUT CLAIM TO ANY PARTICULAR FONT, STYLE, SIZE, OR COLOR.

FOR CONSULTING IN THE FIELD OF STRUCTURAL ENGINEERING; ENGINEERING SERVICES, NAMELY, ENGINEERING FOR THE OIL AND GAS, ENERGY, UTILITIES, SECURITY, GOVERNMENT, INDUSTRIAL AND COMMERCIAL MARKETS; STRUCTURAL ENGINEERING DESIGN SERVICES (U.S. CLS. 100 AND 101).

FIRST USE 3-16-2001; IN COMMERCE 3-16-2001. ELLEN PERKINS, EXAMINING ATTORNEY

CLASS 42—SCIENTIFIC AND COMPUTER SERVICES

SN 76-708,712. COMPUSHARE, INC., SANTA ANA, CA. FILED 8-12-2011.

C³

FOR CLOUD COMPUTING FEATURING SOFTWARE THAT ENABLES FINANCIAL SERVICES COMPANIES SUCH AS COMMUNITY BANKS, CREDIT UNIONS AND HEDGE FUNDS TO ACCESS THEIR LEGACY FINANCIAL APPLICATIONS THROUGH ANY WEB-ENABLED DEVICE OVER A SECURE PUBLIC CLOUD, ALLOWS USERS TO HAVE LAYERS OF SECURITY, BUSINESS CONTINUITY RESILIENCY, SCALABILITY, AND ROBUST REMOTE ACCESS TO ALL OF THEIR APPLICATIONS (U.S. CLS. 100 AND 101).

FIRST USE 10-1-2010; IN COMMERCE 10-1-2010. LINDSEY RUBIN, EXAMINING ATTORNEY

SN 85-110,685. NCH MARKETING SERVICES, INC., DEERFIELD, IL. FILED 8-18-2010.

benchmark

THE COLOR(S) RED AND BLACK IS/ARE CLAIMED AS A FEATURE OF THE MARK.

THE MARK CONSISTS OF THE WORD "BENCHMARK" IN THE COLOR BLACK WITH RED CURVED LINES ABOVE AND BELOW "NCH" PORTION OF THE MARK.

FOR ONLINE COUPON INFORMATION MANAGEMENT SYSTEM FOR RETAILERS AND COUPON DATA MANAGEMENT SERVICES, NAMELY, PROVIDING ONLINE NON-DOWNLOADABLE SOFTWARE FOR USE IN REVIEWING AND REPORTING MANUFACTURER PAYMENT, FOR INVOICE RECONCILIATION AND ADJUSTMENT INFORMATION AS RELATING TO COUPONS BY STORE LEVEL, FOR ANALYSIS OF COSTS RELATING TO COUPON OFFERS, FOR TRACKING ADJUSTMENTS BY REASON CODE OR MANUFACTURER AS RELATING TO COUPONS, AND FOR CREATING REPORTS GENERATED IN CONNECTION THEREWITH (U.S. CLS. 100 AND 101).

FIRST USE 7-13-2004; IN COMMERCE 7-13-2004. WANDA KAY PRICE, EXAMINING ATTORNEY

CLASS 42—(Continued).

SN 85-123,566. SWINGLEY, PAMELA, DBA REMEMBERIT-NOW!, ORINDA, CA. FILED 9-6-2010.



OWNER OF U.S. REG. NO. 3,964,141.
THE COLOR(S) GREEN, WHITE, AND GRAY IS/ARE CLAIMED AS A FEATURE OF THE MARK.

THE MARK CONSISTS OF THE WORD "REMEMBER" IN GREEN FOLLOWED BY "ITNOW" IN GRAY AND A GREEN AND GRAY PERIOD. THE END OF THE MARK IS ACCENTED BY A GREEN CONVERSATION BOX CONTAINING A WHITE BELL.

FOR PROVIDING ON-LINE NON-DOWNLOADABLE SOFTWARE FOR ALLOWING WEBSITE USERS ON THEIR DESKTOP AND MOBILE PHONE TO MANAGE MEDICATIONS, KEEP A PERSONAL HEALTH RECORD, SET AND SEND REMINDERS, AND CREATE A PRIVATE COMMUNITY; WHERE USERS CAN SCHEDULE CARE, MANAGE CONTACTS, TRACK APPOINTMENTS, PRESCRIPTIONS, HEALTH CARE HISTORY, AND OTHER HEALTH RECORDS (U.S. CLS. 100 AND 101).

LINDA ORNDORFF, EXAMINING ATTORNEY

CLASS 42—(Continued).

SN 85-128,191. CJ 4DPLEX CO., LTD., SEOUL, REPUBLIC OF KOREA, FILED 9-13-2010.

4DPLEX

THE MARK CONSISTS OF STANDARD CHARACTERS WITHOUT CLAIM TO ANY PARTICULAR FONT, STYLE, SIZE, OR COLOR.

PRIORITY CLAIMED UNDER SEC. 44(D) ON REPUBLIC OF KOREA APPLICATION NO. 41-2010-2347, FILED 9-10-2010, REG. NO. 0223565, DATED 12-23-2011, EXPIRES 12-23-2021.

FOR DIGITAL SIGNAL PROCESSING FOR MOVIES AUDIENCE EFFECTS; DEVELOPMENT OF SOFTWARE FOR MOVIES AUDIENCE EFFECTS; DIGITAL SIGNAL PROCESSING FOR MOVIES AUDIENCE EFFECTS IN CINEMAS WITH SPECIAL EFFECTS SUCH AS WIND, SCENT, WATER SPRAY, MOTION, VIBRATION, SMOKE, BUBBLE, LASER OR FLASH; DEVELOPMENT OF SOFTWARE FOR MOVIES AUDIENCE EFFECTS IN CINEMAS WITH SPECIAL EFFECTS SUCH AS WIND, SCENT, WATER SPRAY, MOTION, VIBRATION, SMOKE, BUBBLE, LASER OR FLASH; COMPUTER PROGRAMMING; CONVERSION OF DATA OR DOCUMENTS FROM PHYSICAL TO ELECTRONIC MEDIA; RENTAL OF APPLICATION SOFTWARE (U.S. CLS. 100 AND 101).

RON FAIRBANKS, EXAMINING ATTORNEY

SN 85-127,887. MICROSEISMIC, INC., HOUSTON, TX. FILED 9-13-2010.



OWNER OF U.S. REG. NO. 4,059,227.
NO CLAIM IS MADE TO THE EXCLUSIVE RIGHT TO USE "MICROSEISMIC", APART FROM THE MARK AS SHOWN.

THE MARK CONSISTS OF THE WORDING "MICROSEISMIC" WITH THE LETTERS "M" IN "MICRO" AND FIRST "S" IN "SEISMIC" ARE CAPITALIZED AND A MAGNIFYING GLASS DIRECTED OVER THE CAPITAL LETTER "S" WHERE THE WORD "SEISMIC" APPEARS IN HORIZONTAL STRIPES.

FOR SEISMIC DATA ACQUISITION, MAPPING, PROCESSING AND ANALYSIS SERVICES; SCIENTIFIC AND TECHNOLOGICAL SERVICES, NAMELY, RESERVOIR DATA MONITORING AND ANALYSIS IN THE FIELD OF GEOPHYSICS; GEOLOGICAL ESTIMATIONS AND RESEARCH; TECHNICAL CONSULTATION IN THE FIELD OF GEOPHYSICS, ALL SERVICES FOR OTHERS (U.S. CLS. 100 AND 101).

FIRST USE 0-0-2003; IN COMMERCE 0-0-2003.

LINDA ORNDORFF, EXAMINING ATTORNEY

SN 85-135,921. ALIGN TECHNOLOGY, INC., SAN JOSE, CA. FILED 9-22-2010.

SMILESCORE

THE MARK CONSISTS OF STANDARD CHARACTERS WITHOUT CLAIM TO ANY PARTICULAR FONT, STYLE, SIZE, OR COLOR.

FOR HOSTING AN ONLINE COMMUNITY WEB SITE FEATURING DENTAL INFORMATION, NAMELY, HOSTING AN ONLINE INTERACTIVE WEB SITE UTILIZING A SOFTWARE APPLICATION TO POST, CATEGORIZE, TRACK, MAINTAIN, AND REVIEW A GALLERY OF IMAGES DEPICTING DENTAL TREATMENT OUTCOMES, AND TO FACILITATE USERS' PEER-BASED RECOGNITION OF OUTSTANDING TREATMENT RESULTS (U.S. CLS. 100 AND 101).

FIRST USE 6-9-2011; IN COMMERCE 6-9-2011.

KATHERINE E. HALMEN, EXAMINING ATTORNEY

CLASS 42—(Continued).

SN 85-141,925. COVANCE INC., PRINCETON, NJ. FILED 9-30-2010.

XCELLERATE

THE MARK CONSISTS OF STANDARD CHARACTERS WITHOUT CLAIM TO ANY PARTICULAR FONT, STYLE, SIZE, OR COLOR.

FOR CONDUCTING CLINICAL TRIALS OF PHARMACEUTICALS AND MEDICAL DEVICES; SCIENTIFIC RESEARCH SERVICES, NAMELY, TRACKING, ANALYZING, FORECASTING, AND REPORTING DATA IN THE FIELD OF CLINICAL TRIALS OF PHARMACEUTICALS AND MEDICAL DEVICES (U.S. CLS. 100 AND 101).

MARK RADEMACHER, EXAMINING ATTORNEY

SN 85-149,880. GLABBER, INC., NEWARK, DE. FILED 10-11-2010.

GLABBER

THE MARK CONSISTS OF STANDARD CHARACTERS WITHOUT CLAIM TO ANY PARTICULAR FONT, STYLE, SIZE, OR COLOR.

FOR COMPUTER SERVICES, NAMELY, PROVIDING INTERNET SEARCH ENGINE SERVICES; COMPUTER SERVICES IN THE NATURE OF CUSTOMIZED WEB PAGES FEATURING USER DEFINED INFORMATION, PERSONAL PROFILES AND GENERAL PERSONAL INFORMATION; COMPUTER SERVICES, NAMELY, CREATING AN ONLINE COMMUNITY FOR MEMBERS TO PARTICIPATE IN DISCUSSIONS, GET FEEDBACK FROM OTHER MEMBERS AND THEIR PEERS, FORM VIRTUAL COMMUNITIES, AND ENGAGE IN SOCIAL NETWORKING; FILE SHARING SERVICES, NAMELY, PROVIDING A WEBSITE FEATURING TECHNOLOGY ENABLING USERS TO UPLOAD AND DOWNLOAD ELECTRONIC FILES; ELECTRONIC EXCHANGE SERVICES, NAMELY, PROVIDING A WEBSITE FEATURING TECHNOLOGY ENABLING USERS TO SHARE DATA, GRAPHICS, WEBSITE LINKS, PHOTOS AND VIDEOS (U.S. CLS. 100 AND 101).

JAMES LOVELACE, EXAMINING ATTORNEY

CLASS 42—(Continued).

SN 85-268,139. IBD RESOURCE GROUP, LTD., LAS VEGAS, NV. FILED 3-16-2011.

IBD RESOURCE GROUP

THE MARK CONSISTS OF STANDARD CHARACTERS WITHOUT CLAIM TO ANY PARTICULAR FONT, STYLE, SIZE, OR COLOR.

NO CLAIM IS MADE TO THE EXCLUSIVE RIGHT TO USE "RESOURCE GROUP", APART FROM THE MARK AS SHOWN.

FOR COMPUTER SERVICES, NAMELY, PROVIDING TECHNOLOGIES THAT FACILITATE OR IMPROVE BUILDING DESIGN, CONSTRUCTION AND OPERATIONS LIFE-CYCLE AND THAT ALLOW USERS TO MANAGE, VIEW, STUDY OR USE ONLINE DIGITAL CONTENT AND DOCUMENTATION USED IN DIGITAL MODELS IN THE FIELDS OF BUILDING DESIGN, CONSTRUCTION AND MANAGEMENT; APPLICATION SERVICE PROVIDER, NAMELY, PROVIDING, HOSTING, MANAGING, DEVELOPING, AND MAINTAINING APPLICATIONS, SOFTWARE, WEB SITES, AND DATABASES FOR MANAGING DIGITAL CONTENT AND DOCUMENTATION AND ANALYZING USE OF AND ACCESS OF DIGITAL CONTENT AND DOCUMENTATION IN THE FIELDS OF BUILDING DESIGN, CONSTRUCTION AND MANAGEMENT (U.S. CLS. 100 AND 101).

ZACHARY BELLO, EXAMINING ATTORNEY

SN 85-270,543. SOUNDCHIP SA, BUSSIGNY-LAUSANNE, SWITZERLAND, FILED 3-18-2011.



NO CLAIM IS MADE TO THE EXCLUSIVE RIGHT TO USE "SOUND CHIP", APART FROM THE MARK AS SHOWN.

THE MARK CONSISTS OF THE WORDING "SOUND CHIP" AND A STYLIZED DESIGN COMPRISED OF THREE CONCENTRIC OVALS.

FOR AUDIO ENGINEERING AND ELECTROACOUSTIC DESIGN AND CONSULTING SERVICES IN THE NATURE OF AUDIO ENGINEERING AND CONSULTATION IN THE FIELD OF AUDIO ENGINEERING (U.S. CLS. 100 AND 101).

SEAN CROWLEY, EXAMINING ATTORNEY

CLASS 42—(Continued).

SN 85-284,690. ROSAEN, KARL J., DBA REAL TIME FARMS, LLC, ANN ARBOR, MI. FILED 4-3-2011.

Real Time Farms

THE MARK CONSISTS OF STANDARD CHARACTERS WITHOUT CLAIM TO ANY PARTICULAR FONT, STYLE, SIZE, OR COLOR.

NO CLAIM IS MADE TO THE EXCLUSIVE RIGHT TO USE "FARMS", APART FROM THE MARK AS SHOWN.

FOR PROVIDING A WEB SITE FEATURING TECHNOLOGY THAT ENABLES USERS TO ACCESS AND SHARE INFORMATION ON WHERE THEIR FOOD COMES FROM AND TO USE TOOLS TO PROMOTE AND/OR SELL THEIR GOODS; PROVIDING TEMPORARY USE OF NON-DOWNLOADABLE SOFTWARE FOR USE IN IDENTIFYING THE SOURCE OR SOURCES OF FOOD PRODUCTS TO FACILITATE MENU MANAGEMENT AND FOOD RETAILING OPERATIONS (U.S. CLS. 100 AND 101).

FIRST USE 4-30-2010; IN COMMERCE 4-30-2010.
NICHOLAS ALTREE, EXAMINING ATTORNEY



SN 85-285,075. GAS TECHNOLOGY INSTITUTE, DES PLAINES, IL. FILED 4-4-2011.

IH2

THE MARK CONSISTS OF STANDARD CHARACTERS WITHOUT CLAIM TO ANY PARTICULAR FONT, STYLE, SIZE, OR COLOR.

FOR SCIENTIFIC RESEARCH, DEVELOPMENT AND DEMONSTRATION RELATING TO CATALYST TECHNOLOGY FOR RENEWABLE ENERGY SUPPLY, TRANSMISSION, DISTRIBUTION, UTILIZATION AND CONSERVATION; ENGINEERING CONSULTING SERVICES IN THE FIELD OF RENEWABLE GASEOUS AND LIQUID FUEL PRODUCTION AND OTHER TECHNOLOGIES RELATED TO THE PRODUCTION, TRANSMISSION, STORAGE, DISTRIBUTION AND END-USE OF SUCH RENEWABLE GASEOUS AND LIQUID FUELS (U.S. CLS. 100 AND 101).

TRACY CROSS, EXAMINING ATTORNEY

CLASS 42—(Continued).

SN 85-286,610. OASIS DIGITAL, INC., SEATTLE, WA. FILED 4-5-2011.

OASIS

THE MARK CONSISTS OF STANDARD CHARACTERS WITHOUT CLAIM TO ANY PARTICULAR FONT, STYLE, SIZE, OR COLOR.

FOR SOFTWARE AS A SERVICE (SAAS) SERVICES FOR THE HOSPITALITY INDUSTRY FEATURING NON-DOWNLOADABLE SOFTWARE FOR ACCESSING LOCAL EVENT SCHEDULES AND RELATED INFORMATION VIA CALENDARS, INTERACTIVE VOICE RESPONSE (IVR), AND SHORT MESSAGE SERVICE (SMS) SYSTEMS MAINTAINED BY OTHERS; SOFTWARE SERVICES FOR THE HOSPITALITY INDUSTRY FEATURING TEMPORARY USE OF NON-DOWNLOADABLE SOFTWARE TO PROVIDE ACCESS TO CUSTOMER-DEFINED GENERATED CONTENT AND CONTENT OF OTHERS AUTOMATICALLY SELECTED AND CUSTOMIZED BASED ON THE KNOWN OR ESTIMATED GEOGRAPHICAL LOCATION OF AN INTERNET, MOBILE TELEPHONE OR OTHER WIRED OR WIRELESS DIGITAL NETWORK BASED CUSTOMER FROM WITHIN A CLOSED NETWORK MAINTAINED BY OTHERS (U.S. CLS. 100 AND 101).

CURTIS FRENCH, EXAMINING ATTORNEY



SN 85-287,876. JOHNSON & JOHNSON, NEW BRUNSWICK, NJ. FILED 4-6-2011.

IMUNITI

THE MARK CONSISTS OF STANDARD CHARACTERS WITHOUT CLAIM TO ANY PARTICULAR FONT, STYLE, SIZE, OR COLOR.

FOR CONDUCTING CLINICAL TRIALS FOR PHARMACEUTICAL SERVICES FEATURING PHARMACEUTICAL PREPARATIONS (U.S. CLS. 100 AND 101).

JEAN IM, EXAMINING ATTORNEY

CLASS 42—(Continued).

SN 85-297,318. MIYAZAKI, SO, SAN FRANCISCO, CA. FILED 4-18-2011.



NO CLAIM IS MADE TO THE EXCLUSIVE RIGHT TO USE "FREE APP", APART FROM THE MARK AS SHOWN. THE COLOR(S) GOLD, BROWN, RED, GRAY AND WHITE IS/ARE CLAIMED AS A FEATURE OF THE MARK.

THE MARK CONSISTS OF A DESIGN OF A KING'S CROWN IN GOLD AND RED OUTLINED IN BROWN, PLACED ABOVE A DESIGN WITH SWIRLS AND FLOWERS IN BROWN AND A RED OVAL IN THE CENTER, WHEREIN THE WORDING "FREEAPP" IN GRAY WITH BROWN OUTLINES IS WRITTEN BELOW THE DESIGN AND THE WORDING "KING" IS WRITTEN BELOW THE WORDING "FREEAPP" IN GOLD WITH BROWN OUTLINES. INSIDE THE LETTER "G" OF THE WORDING "KING" IS A DESIGN OF A CROWN IN GOLD WITH BROWN OUTLINES. THERE ARE GRAY SHADOWS UNDERNEATH THE WORDING AND WHITE FOUR POINTED STARS ON THE SWIRLING DESIGN BENEATH THE CROWN, THE RED OVAL IN THE CENTER, ON THE LETTERS, "K" AND "G" TO INDICATE SPARKLE.

FOR APPLICATION SERVICE PROVIDER, NAMELY, HOSTING COMPUTER SOFTWARE APPLICATIONS FOR MOBILE PHONES OF OTHERS (U.S. CLS. 100 AND 101).

JANET LEE, EXAMINING ATTORNEY

SN 85-297,321. MIYAZAKI, SO, SAN FRANCISCO, CA. FILED 4-18-2011.

FREEAPPKING

THE MARK CONSISTS OF STANDARD CHARACTERS WITHOUT CLAIM TO ANY PARTICULAR FONT, STYLE, SIZE, OR COLOR.

FOR APPLICATION SERVICE PROVIDER, NAMELY, HOSTING COMPUTER SOFTWARE APPLICATIONS OF OTHERS FOR MOBILE PHONES (U.S. CLS. 100 AND 101).

JANET LEE, EXAMINING ATTORNEY

CLASS 42—(Continued).

SN 85-299,177. SAVVIENT, INC., LOS ANGELES, CA. FILED 4-19-2011.



NO CLAIM IS MADE TO THE EXCLUSIVE RIGHT TO USE "CLOUD RECORDS" AND "COMPANY", APART FROM THE MARK AS SHOWN.

THE COLOR(S) LIGHT BLUE, DARK BLUE, BLACK, AND WHITE IS/ARE CLAIMED AS A FEATURE OF THE MARK.

THE MARK CONSISTS OF THE WORDING "CLOUD RECORDS A SAVVIENT COMPANY" AND A DESIGN OF A DARK BLUE AND BLACK FOLDER DISPLAYING PARTIAL CLOUDS IN WHITE AND LIGHT BLUE. THE WORD "CLOUD" IS IN DARK BLUE, THE WORD "RECORDS" IS IN BLACK, AND THE WORDING "A SAVVIENT COMPANY" IS IN BLACK.

FOR PROVIDING TEMPORARY USE OF ON-LINE NON-DOWNLOADABLE SOFTWARE AND APPLICATIONS FOR COORDINATED CARE INFORMATION TECHNOLOGY PLATFORMS FOR USE IN THE FIELD OF HEALTHCARE; SOFTWARE AS A SERVICE (SAAS) SERVICES FEATURING SOFTWARE FOR CONTROLLING AND MANAGING PATIENT MEDICAL INFORMATION; SOFTWARE AS A SERVICE (SAAS) SERVICES FEATURING SOFTWARE IN THE FIELD OF APPLICATION AND DATABASE INTEGRATION; SOFTWARE AS A SERVICE (SAAS) SERVICES FEATURING SOFTWARE FOR THE MINING, REPORTING AND ANALYSIS OF HEALTH INFORMATION EXCHANGE (HIE) DATA; PROVIDING A SECURE ELECTRONIC ONLINE SYSTEM FEATURING TECHNOLOGY WHICH ALLOWS THE SECURE DELIVERY OF MEDICAL RECORD DATA TO MEDICAL CARE PROVIDERS VIA INTERFACES TO LABORATORY INFORMATION SYSTEMS (LIS), HOSPITAL INFORMATION SYSTEMS (HIS), RADIOLOGY INFORMATION SYSTEMS (RIS) ELECTRONIC PRESCRIBING SYSTEMS (EPS), ELECTRONIC MEDICAL RECORDS (EMRS) AND ELECTRONIC HEALTH RECORDS (EHRS); SOFTWARE AS A SERVICE (SAAS) SERVICES FEATURING SOFTWARE IN THE FIELD OF CONTROLLED ACCESS SERVICE WHICH MAINTAINS DATABASES OF PATIENT HEALTH INFORMATION AND PROVIDES ACCESS TO SUCH INFORMATION TO HEALTH CARE PERSONNEL AND HEALTH CARE INSTITUTIONS (U.S. CLS. 100 AND 101).

YAT SYE, LEE, EXAMINING ATTORNEY

CLASS 42—(Continued).

SN 85-301,705. UNITEDHEALTH GROUP INCORPORATED, MINNETONKA, MN. FILED 4-21-2011.

UNITEDHEALTHCARE

THE MARK CONSISTS OF STANDARD CHARACTERS WITHOUT CLAIM TO ANY PARTICULAR FONT, STYLE, SIZE, OR COLOR.

OWNER OF U.S. REG. NOS. 1,967,622, 3,269,588 AND OTHERS.

FOR PROVIDING A WEBSITE FEATURING TEMPORARY USE OF NON-DOWNLOADABLE SOFTWARE ALLOWING USERS TO ACCESS, UPDATE, AND MANAGE ELECTRONIC HEALTH RECORDS; PROVIDING A WEBSITE FEATURING TEMPORARY USE OF NON-DOWNLOADABLE SOFTWARE FOR PROVIDING HEALTH AND MEDICARE INFORMATION; PROVIDING TEMPORARY USE OF ONLINE NON-DOWNLOADABLE SOFTWARE FEATURING HEALTH RISK APPRAISALS, QUIZZES, SELF-ASSESSMENTS, CALCULATORS, AND GOAL TRACKING IN THE FIELDS OF HEALTH AND WELLNESS (U.S. CLS. 100 AND 101).

AMY HELLA, EXAMINING ATTORNEY

SN 85-302,612. RESPONSYS, INC., SAN BRUNO, CA. FILED 4-22-2011.

INTERACT SUITE

THE MARK CONSISTS OF STANDARD CHARACTERS WITHOUT CLAIM TO ANY PARTICULAR FONT, STYLE, SIZE, OR COLOR.

OWNER OF U.S. REG. NOS. 2,538,509, 3,523,277 AND OTHERS.

NO CLAIM IS MADE TO THE EXCLUSIVE RIGHT TO USE "SUITE", APART FROM THE MARK AS SHOWN.

FOR SOFTWARE AS A SERVICE (SAAS) SERVICES, NAMELY, PROVIDING TEMPORARY USE OF ON-LINE NON-DOWNLOADABLE SOFTWARE FOR DESIGN, MANAGEMENT, AUTOMATION, AND DEPLOYMENT OF MARKETING CAMPAIGNS AND COMMUNICATIONS, AND FOR DATA INTEGRATION, DATA TRANSFER BETWEEN DIFFERENT COMPUTER PROGRAMS, DATA ANALYSIS AND REPORTING, ALL IN THE FIELD OF MARKETING CAMPAIGNS AND COMMUNICATIONS; APPLICATION SERVICE PROVIDER FEATURING APPLICATION PROGRAMMING INTERFACE (API) SOFTWARE FOR USE IN BUILDING SOFTWARE APPLICATIONS IN THE FIELD OF MARKETING CAMPAIGNS AND COMMUNICATIONS; AND CONSULTING SERVICES ASSISTING IN THE OF USE OF ALL THE AFORESAID SOFTWARE (U.S. CLS. 100 AND 101).

FIRST USE 10-29-2009; IN COMMERCE 10-29-2009.

RAUL CORDOVA, EXAMINING ATTORNEY

CLASS 42—(Continued).

SN 85-303,991. PITMAKER, LLC, HUMBLE, TX. FILED 4-25-2011.

PITMAKER

THE MARK CONSISTS OF STANDARD CHARACTERS WITHOUT CLAIM TO ANY PARTICULAR FONT, STYLE, SIZE, OR COLOR.

FOR CUSTOM DESIGN OF BARBECUE SMOKERS, BARBECUE TRAILERS, GRILLS, AND OUTDOOR KITCHENS BASED ON PERSONAL SELECTIONS MADE BY THE CUSTOMER (U.S. CLS. 100 AND 101).

FIRST USE 2-1-2009; IN COMMERCE 2-1-2009.

BILL DAWE, EXAMINING ATTORNEY

SN 85-307,241. MUFASA HOLDINGS LLC, MIAMI, FL. FILED 4-28-2011.

WatchFacts

THE MARK CONSISTS OF STANDARD CHARACTERS WITHOUT CLAIM TO ANY PARTICULAR FONT, STYLE, SIZE, OR COLOR.

FOR AUTHENTICATION, GRADING AND INSPECTION SERVICES FOR OTHERS, IN THE FIELD OF WATCHES AND CLOCKS, FOR PURPOSES OF COMMERCIAL CERTIFICATION (U.S. CLS. 100 AND 101).

FIRST USE 10-15-2010; IN COMMERCE 10-15-2010.

ELISSA GARBER KON, EXAMINING ATTORNEY

SN 85-309,085. GLOBAL UNIVERSAL DESIGN COMMISSION, INC., SYRACUSE, NY. FILED 4-30-2011.

GUDC

THE MARK CONSISTS OF STANDARD CHARACTERS WITHOUT CLAIM TO ANY PARTICULAR FONT, STYLE, SIZE, OR COLOR.

FOR DEVELOPMENT OF VOLUNTARY STANDARDS FOR THE PROMOTION, UNDERSTANDING AND USE OF UNIVERSAL DESIGN IN THE DESIGN AND DEVELOPMENT OF BUILDINGS, PRODUCTS AND ENVIRONMENTS TO BE USEABLE BY ALL PEOPLE, TO THE GREATEST EXTENT POSSIBLE WITHOUT THE NEED FOR ADAPTATION, RETROFITTING OR SPECIALIZED DESIGN, TESTING, ANALYSIS AND EVALUATION OF THE GOODS AND SERVICES OF OTHERS FOR THE PURPOSE OF CERTIFICATION (U.S. CLS. 100 AND 101).

MICHAEL WEBSTER, EXAMINING ATTORNEY

CLASS 42—(Continued).

SN 85-310,752. LUNDSTROM INSURANCE AGENCY, INC.,
ELGIN, IL. FILED 5-3-2011.

INSURE MY MEMORY

THE MARK CONSISTS OF STANDARD CHARACTERS WITHOUT CLAIM TO ANY PARTICULAR FONT, STYLE, SIZE, OR COLOR.

FOR COMPUTER SERVICES, NAMELY, HOSTING AN INTERACTIVE WEB SITE THAT ALLOWS AUTOMATICALLY AND/OR MANUALLY PROVIDING ALARMING, ALERTING TO AND/OR REMINDING OF UPCOMING DATES INCLUDING DUE DATES AND RENEWAL DUE DATES, FOR USERS, SUCH AS EMPLOYEES, SALESPERSONS, CUSTOMERS, CORPORATIONS, BUSINESSES, INDIVIDUALS, FAMILIES AND OTHER ORGANIZED ENTITIES, INSURANCE USERS OR INSURANCE AGENCIES, AND/OR INSURANCE BROKERAGES REPRESENTING INSURANCE CARRIERS, THAT USE AND/OR PURCHASE PROTECTIONS, INCLUDING BUSINESS INSURANCE, LIFE INSURANCE, HEALTH INSURANCE, GROUP HEALTH INSURANCE, GROUP BENEFITS INSURANCE, VEHICLE INSURANCE, HOMEOWNERS INSURANCE, CHURCH INSURANCE, VETERINARY INSURANCE, EQUINE INSURANCE AND OTHER SPECIALTY INSURANCES (U.S. CLS. 100 AND 101).

KATHLEEN LORENZO, EXAMINING ATTORNEY

SN 85-316,627. REDDIT, INC., NEW YORK, NY. FILED 5-10-2011.

REDDIT GADGETGUIDE

THE MARK CONSISTS OF STANDARD CHARACTERS WITHOUT CLAIM TO ANY PARTICULAR FONT, STYLE, SIZE, OR COLOR.

OWNER OF U.S. REG. NOS. 3,474,493 AND 3,786,519.

NO CLAIM IS MADE TO THE EXCLUSIVE RIGHT TO USE "GADGET GUIDE", APART FROM THE MARK AS SHOWN.

FOR PROVIDING ONLINE NEWS AND INFORMATION IN THE FIELD OF COMPUTER SOFTWARE AND HARDWARE; PROVIDING ONLINE NEWS AND INFORMATION IN THE FIELD OF INFORMATION TECHNOLOGY (U.S. CLS. 100 AND 101).

FIRST USE 1-17-2007; IN COMMERCE 1-17-2007.

WANDA KAY PRICE, EXAMINING ATTORNEY

CLASS 42—(Continued).

SN 85-317,483. 3QC, INC, FOLSOM, CA. FILED 5-10-2011.

3QC ENLIGHTENED BUILDINGS

THE MARK CONSISTS OF STANDARD CHARACTERS WITHOUT CLAIM TO ANY PARTICULAR FONT, STYLE, SIZE, OR COLOR.

NO CLAIM IS MADE TO THE EXCLUSIVE RIGHT TO USE "BUILDINGS", APART FROM THE MARK AS SHOWN.

FOR CONSULTING IN THE FIELDS OF ENGINEERING AND ARCHITECTURE TO BUILDING OWNERS, ARCHITECTS, AND ENGINEERS IN THE AREAS OF BUILDING COMMISSIONING, ENERGY/BUILDING AUDITS, SUSTAINABILITY, LEED NAVIGATION AND LABOR COMPLIANCE SERVICES (U.S. CLS. 100 AND 101).

FIRST USE 12-1-2009; IN COMMERCE 1-1-2010.

BRIAN CALLAGHAN, EXAMINING ATTORNEY

SN 85-324,412. , PENTAD SYSTEMS, LLC, SPOKANE, WA.
FILED 5-18-2011.



NO CLAIM IS MADE TO THE EXCLUSIVE RIGHT TO USE "SYSTEMS", APART FROM THE MARK AS SHOWN.

THE MARK CONSISTS OF A FIVE-POINTED STAR CONTAINING FOUR SMALLER EIGHT-POINTED WHITE STARS LOCATED ON THE BODY OF THE FIVE-POINTED STAR. VARIOUS LINES GIVE THE FIVE-POINTED STAR THE APPEARANCE OF THREE DIMENSIONS. THE WORDING "PENTAD SYSTEMS" APPEARS TO THE RIGHT AND IN FRONT OF THE FIVE POINTED STAR WITH THE LOWER RIGHT LEG OF THE STAR INTERSECTING THE WORD LARGER AND FIRST WORD.

THE WORD(S) "PENTAD" HAS NO MEANING IN A FOREIGN LANGUAGE.

FOR APPLICATION SERVICE PROVIDER (ASP), NAMELY, HOSTING COMPUTER SOFTWARE APPLICATIONS OF OTHERS; COMPUTER CONSULTATION; COMPUTER CONSULTATION IN THE FIELD OF COMPUTER SECURITY, NAMELY, RESTRICTING ACCESS TO AND BY COMPUTER NETWORKS TO AND OF UNDESIRED WEB SITES, MEDIA AND INDIVIDUALS AND FACILITIES; COMPUTER CONSULTATION IN THE FIELD OF KNOWLEDGE MANAGEMENT, NAMELY, ACTING AS AN APPLICATION SERVICE PROVIDER FOR SEARCHING AND RETRIEVING INFORMATION FROM DATABASES AND COMPUTER NETWORKS; COMPUTER CONSULTATION IN THE FIELD OF KNOWLEDGE MANAGEMENT, NAMELY, ACTING AS AN APPLICATION SERVICE PROVIDER FOR THE COLLECTION, EDITING, ORGANIZING, MODIFYING, BOOK MARKING, TRANSMISSION, STORAGE AND SHARING OF DATA AND INFORMATION; COMPUTER HARDWARE AND SOFTWARE CONSULTING SERVICES; COMPUTER HARDWARE AND SOFTWARE DESIGN; COMPUTER PROGRAMMING SERVICES; COMPUTER PROGRAMMING AND SOFTWARE DESIGN; COMPUTER SERVICE, NAMELY, ACT-

CLASS 42—(Continued).

ING AS AN APPLICATION SERVICE PROVIDER IN THE FIELD OF KNOWLEDGE MANAGEMENT TO HOST COMPUTER APPLICATION SOFTWARE FOR CREATING SEARCHABLE DATABASES OF INFORMATION AND DATA; COMPUTER SERVICE, NAMELY, ACTING AS AN APPLICATION SERVICE PROVIDER IN THE FIELD OF KNOWLEDGE MANAGEMENT TO HOST COMPUTER APPLICATION SOFTWARE FOR SEARCHING AND RETRIEVING INFORMATION FROM DATABASES AND COMPUTER NETWORKS; COMPUTER SERVICE, NAMELY, ACTING AS AN APPLICATION SERVICE PROVIDER IN THE FIELD OF INFORMATION MANAGEMENT TO HOST COMPUTER APPLICATION SOFTWARE FOR THE PURPOSE OF BUSINESS PLANNING, BUSINESS MANAGEMENT, CUSTOMER SERVICE, HUMAN RESOURCES, INFORMATION MANAGEMENT, PROJECT MANAGEMENT, ASSET MANAGEMENT, AND PROCUREMENT; COMPUTER SERVICES IN THE NATURE OF CUSTOMIZED WEB PAGES FEATURING BUSINESS AND PERSONAL INFORMATION DERIVED FROM DATABASE STRUCTURES; COMPUTER SOFTWARE CONSULTING; COMPUTER SOFTWARE DESIGN, COMPUTER PROGRAMMING, AND MAINTENANCE OF COMPUTER SOFTWARE; CONSULTING SERVICES IN THE FIELD OF HOSTING COMPUTER SOFTWARE APPLICATIONS CUSTOMIZATION OF COMPUTER HARDWARE AND SOFTWARE; PLATFORM AS A SERVICE (PAAS) FEATURING COMPUTER SOFTWARE PLATFORMS FOR DATABASE ACCESS AND MANAGEMENT, NAMELY, FOR BUSINESS PLANNING, BUSINESS MANAGEMENT, CUSTOMER SERVICE, HUMAN RESOURCES, INFORMATION MANAGEMENT, PROJECT MANAGEMENT, ASSET MANAGEMENT, AND PROCUREMENT; SOFTWARE AS A SERVICE (SAAS) FEATURING COMPUTER SOFTWARE FOR DATABASE ACCESS AND MANAGEMENT, NAMELY, FOR BUSINESS PLANNING, BUSINESS MANAGEMENT, CUSTOMER SERVICE, HUMAN RESOURCES, INFORMATION MANAGEMENT, PROJECT MANAGEMENT, ASSET MANAGEMENT, AND PROCUREMENT (U.S. CLS. 100 AND 101).

FIRST USE 5-1-2004; IN COMMERCE 5-1-2004.
HOWARD SMIGA, EXAMINING ATTORNEY

SN 85-331,146. PARK CITY ENTERTAINMENT, INC., SALT LAKE CITY, UT. FILED 5-26-2011.

Interactive Health Partner

THE MARK CONSISTS OF STANDARD CHARACTERS WITHOUT CLAIM TO ANY PARTICULAR FONT, STYLE, SIZE, OR COLOR.

NO CLAIM IS MADE TO THE EXCLUSIVE RIGHT TO USE "INTERACTIVE HEALTH", APART FROM THE MARK AS SHOWN.

FOR PROVIDING A SECURED-ACCESS, MEMBERS ONLY WEBSITE FEATURING TECHNOLOGY THAT GIVES MEMBERS THE ABILITY TO STORE AND ACCESS HEALTH AND EXERCISE INFORMATION (U.S. CLS. 100 AND 101).

FIRST USE 12-31-2005; IN COMMERCE 12-31-2005.
JEFF DEFORD, EXAMINING ATTORNEY

CLASS 42—(Continued).

SN 85-331,178. PARK CITY ENTERTAINMENT, INC., SALT LAKE CITY, UT. FILED 5-26-2011.

IHP Certified

THE MARK CONSISTS OF STANDARD CHARACTERS WITHOUT CLAIM TO ANY PARTICULAR FONT, STYLE, SIZE, OR COLOR.

NO CLAIM IS MADE TO THE EXCLUSIVE RIGHT TO USE "CERTIFIED", APART FROM THE MARK AS SHOWN.

FOR DEVELOPMENT OF VOLUNTARY STANDARDS FOR COMMUNICATING AND STORING HEALTH AND EXERCISE INFORMATION (U.S. CLS. 100 AND 101).

FIRST USE 12-31-2005; IN COMMERCE 12-31-2005.
JEFF DEFORD, EXAMINING ATTORNEY

SN 85-336,564. VIROMED CO., LTD., SEOUL, REPUBLIC OF KOREA, FILED 6-2-2011.

VM BIOPHARMA

THE MARK CONSISTS OF STANDARD CHARACTERS WITHOUT CLAIM TO ANY PARTICULAR FONT, STYLE, SIZE, OR COLOR.

NO CLAIM IS MADE TO THE EXCLUSIVE RIGHT TO USE "BIOPHARMA", APART FROM THE MARK AS SHOWN.

FOR PHARMACEUTICAL RESEARCH AND DEVELOPMENT (U.S. CLS. 100 AND 101).

DAVID HOFFMAN, EXAMINING ATTORNEY

SN 85-338,652. CELERITY GOVERNMENT SOLUTIONS, LLC, MCLEAN, VA. FILED 6-6-2011.



OWNER OF U.S. REG. NOS. 3,531,467, 3,576,641 AND OTHERS.

NO CLAIM IS MADE TO THE EXCLUSIVE RIGHT TO USE "GOVERNMENT SOLUTIONS", APART FROM THE MARK AS SHOWN.

THE MARK CONSISTS OF "CELERITY GOVERNMENT SOLUTIONS" WITH A "C" INSIDE OF A SPHERE.

FOR COMPUTER CONSULTING SERVICES IN THE FIELD OF PROGRAMMING, ANALYSIS, DESIGN AND IMPLEMENTATION, RESEARCH AND DEVELOPMENT FOR NEW INFORMATION TECHNOLOGY PRODUCTS FOR OTHERS, IN THE FIELD OF INFORMATION TECHNOLOGY (U.S. CLS. 100 AND 101).

FIRST USE 5-1-2011; IN COMMERCE 5-1-2011.
HELENE LIWINSKI, EXAMINING ATTORNEY

CLASS 42—(Continued).

SN 85-340,856. CMDIRECT, INC., DENVER, CO. FILED 6-8-2011.

CMDirect

THE MARK CONSISTS OF STANDARD CHARACTERS WITHOUT CLAIM TO ANY PARTICULAR FONT, STYLE, SIZE, OR COLOR.

FOR PLATFORM AS A SERVICE (PAAS) FEATURING COMPUTER SOFTWARE PLATFORMS FOR THE NEGOTIATION AND TRADING OF PHYSICAL COMMODITIES; PROVIDING TEMPORARY USE OF ON-LINE NON-DOWNLOADABLE SOFTWARE PLATFORMS FOR THE NEGOTIATION AND TRADING OF PHYSICAL COMMODITIES (U.S. CLS. 100 AND 101).

FIRST USE 5-13-2010; IN COMMERCE 5-13-2010.
DAVID H. STINE, EXAMINING ATTORNEY

CLASS 42—(Continued).

SN 85-355,360. SHOWCASE PUBLICATIONS, INC., TOMS RIVER, NJ. FILED 6-24-2011.

TRUCKSHOPPER.COM

THE MARK CONSISTS OF STANDARD CHARACTERS WITHOUT CLAIM TO ANY PARTICULAR FONT, STYLE, SIZE, OR COLOR.

OWNER OF U.S. REG. NOS. 2,014,611 AND 2,779,219. SEC. 2(F).

FOR COMPUTER SERVICES, NAMELY, PROVIDING TEMPORARY USE OF NON-DOWNLOADABLE SEARCH ENGINE SOFTWARE FOR USE IN SEARCHING DATABASES FEATURING LISTINGS OF TRUCKS, TRAILERS AND RELATED EQUIPMENT FOR PURCHASE AND SALE AND INFORMATION, PHOTOGRAPHS, SPECIFICATIONS, PRICING, AND REVIEWS IN THE FIELD OF TRUCKS, TRAILERS AND RELATED EQUIPMENT; COMPUTER SERVICES, NAMELY, CREATING, MAINTAINING AND HOSTING CUSTOMIZED WEB PAGES OF OTHERS FEATURING USER-DEFINED INFORMATION, PROFILES, PHOTOGRAPHS AND INFORMATION FOR THE PURPOSE OF ADVERTISING TRUCKS, TRAILERS AND RELATED EQUIPMENT FOR SALE (U.S. CLS. 100 AND 101).

FIRST USE 8-31-1997; IN COMMERCE 8-31-1997.
TARAH HARDY, EXAMINING ATTORNEY

SN 85-348,738. COMPREHENSIVE NEUROSCIENCE, INC., MIRAMAR, FL. FILED 6-17-2011.



NO CLAIM IS MADE TO THE EXCLUSIVE RIGHT TO USE "COMPREHENSIVE CLINICAL DEVELOPMENT", APART FROM THE MARK AS SHOWN.

THE MARK CONSISTS OF THE WORDS "COMPREHENSIVE" IN LARGER CAPITAL LETTERS WITH THE WORDS "CLINICAL DEVELOPMENT" OFFSET AND BELOW THE WORD "COMPREHENSIVE" AND WHERE THE "O" OF THE WORD "COMPREHENSIVE" IS MADE FROM A GRAPHIC OF A NOVA WITH A WIDER ELLIPTICAL ORBIT TRACED IN APPROXIMATELY AT 220 ARC AROUND THE NOVA.

FOR MEDICAL AND SCIENTIFIC RESEARCH; PHARMACEUTICAL PRODUCT EVALUATION; PHARMACEUTICAL RESEARCH SERVICES (U.S. CLS. 100 AND 101).

FIRST USE 3-30-2011; IN COMMERCE 3-30-2011.
MIDGE BUTLER, EXAMINING ATTORNEY

SN 85-357,680. BRICKMAN, ANDREW L., MIAMI, FL. FILED 6-28-2011.

CHEER

THE MARK CONSISTS OF STANDARD CHARACTERS WITHOUT CLAIM TO ANY PARTICULAR FONT, STYLE, SIZE, OR COLOR.

FOR PROVIDING AN INTERACTIVE WEBSITE FEATURING TECHNOLOGY THAT ALLOWS USERS TO ENTER, ACCESS AND SHARE INFORMATION IN THE FIELDS OF EDUCATION, HEALTH, AND ECONOMIC RESOURCES (U.S. CLS. 100 AND 101).

JOHN WILKE, EXAMINING ATTORNEY

CLASS 42—(Continued).

SN 85-373,733. VMWARE, INC., PALO ALTO, CA. FILED 7-18-2011.

VNOW

THE MARK CONSISTS OF STANDARD CHARACTERS WITHOUT CLAIM TO ANY PARTICULAR FONT, STYLE, SIZE, OR COLOR.

FOR PROVIDING TEMPORARY USE OF ON-LINE NON-DOWNLOADABLE PRODUCTIVITY AND ENTERPRISE OFFICE SUITE SOFTWARE, NAMELY, COMMUNICATIONS SOFTWARE AND GROUPWARE FOR USE IN WORD PROCESSING, ELECTRONIC MAIL, INSTANT MESSAGING, WEB COLLABORATION, DOCUMENT SHARING; PROVIDING TEMPORARY USE OF ON-LINE NON-DOWNLOADABLE SOFTWARE FOR USE IN ORGANIZING, ANALYZING AND PRESENTING DATA; PROVIDING SOFTWARE DEVELOPMENT, SOFTWARE DESIGN AND SOFTWARE MANAGEMENT SERVICES FOR CUSTOMIZED COMPUTER APPLICATIONS (U.S. CLS. 100 AND 101).

ANN E. SAPPENFIELD, EXAMINING ATTORNEY

SN 85-373,736. VMWARE, INC., PALO ALTO, CA. FILED 7-18-2011.

VQUO

THE MARK CONSISTS OF STANDARD CHARACTERS WITHOUT CLAIM TO ANY PARTICULAR FONT, STYLE, SIZE, OR COLOR.

FOR PROVIDING TEMPORARY USE OF ON-LINE NON-DOWNLOADABLE PRODUCTIVITY AND ENTERPRISE OFFICE SUITE SOFTWARE, NAMELY, COMMUNICATIONS SOFTWARE AND GROUPWARE FOR USE IN WORD PROCESSING, ELECTRONIC MAIL, INSTANT MESSAGING, WEB COLLABORATION, DOCUMENT SHARING; PROVIDING TEMPORARY USE OF ON-LINE NON-DOWNLOADABLE SOFTWARE FOR USE IN ORGANIZING, ANALYZING AND PRESENTING DATA; PROVIDING SOFTWARE DEVELOPMENT, SOFTWARE DESIGN AND SOFTWARE MANAGEMENT SERVICES FOR CUSTOMIZED COMPUTER APPLICATIONS (U.S. CLS. 100 AND 101).

ANN E. SAPPENFIELD, EXAMINING ATTORNEY

CLASS 42—(Continued).

SN 85-374,582. ANDAGO INGENIERIA, S.L., 28904 GETAFE, MADRID, SPAIN, FILED 7-19-2011.



OWNER OF ERPN CMNTY TM OFC REG. NO. 10016426, DATED 11-2-2011, EXPIRES 6-2-2021.

THE COLOR(S) BLACK, WHITE, GRAY, GREEN, LIGHT BLUE AND DARK BLUE IS/ARE CLAIMED AS A FEATURE OF THE MARK.

THE MARK CONSISTS OF THE WORD "CAREFY" IN STYLIZED DARK BLUE FONT TO THE RIGHT OF A CIRCLE OUTLINED IN DARK BLUE AND WITH AN INTERIOR OF LIGHT BLUE AND WHITE. IN THE CIRCLE APPEARS A REPRESENTATION OF A WINGED INSECT WITH BLUE UPPER WINGS THAT EXTEND OUTSIDE THE CIRCLE, GREEN LOWER WINGS AND A BLACK AND WHITE BODY. GRAY SHADOWING APPEARS BENEATH THE DESIGN AND LETTERING.

FOR RESEARCH AND DESIGN OF COMPUTER APPLICATION SOFTWARE FOR MOBILE PHONES, HANDHELD COMPUTER, COMPUTERS, AND TABLET COMPUTERS, NAMELY, SOFTWARE PROVIDING PERSONALIZED HEALTH MONITORING OF WEIGHT, BLOOD PRESSURE, BLOOD GLUCOSE, BODY TEMPERATURE, RESPIRATION, OXYGEN AND HEART RATE USING WIRELESS SENSORS OR MANUAL INPUT; COMPUTER CONSULTANCY SERVICES; DESIGN AND DEVELOPMENT OF COMPUTER HARDWARE AND SOFTWARE; COMPUTER SYSTEMS DESIGN SERVICES; DESIGNING, CREATING, MAINTAINING, AND HOSTING MEDICAL INFORMATION WEBSITES FOR OTHERS FEATURING ON-LINE NON-DOWNLOADABLE SOFTWARE THAT ENABLES USERS TO VIEW, MODIFY OR DELETE THEIR VITAL SIGNS DATA AND ALLOWS USERS TO SHARE THEIR DATA WITH OTHER USERS AND HEALTH CARE PROFESSIONALS; ENGINEERING AND DESIGN CONSULTANCY IN RELATION TO COMPUTER SYSTEMS; TECHNOLOGY SPECIFICATION, NAMELY, ANALYZING TECHNOLOGY REQUIREMENTS AND DEVELOPING RECOMMENDATIONS FOR THE COMPUTER SOFTWARE AND SYSTEMS AND OTHER TECHNOLOGY NEEDED TO MEET THOSE REQUIREMENTS, IN THE FIELD OF WELLNESS AND HEALTH CARE; GRAPHIC DESIGN; TECHNICAL PROJECT STUDIES, NAMELY, CONDUCTING OF FEASIBILITY STUDIES AND TECHNICAL WRITING FOR OTHERS IN CONNECTION THEREWITH; ENGINEERING, TECHNICAL SURVEYING (U.S. CLS. 100 AND 101).

STEVEN PEREZ, EXAMINING ATTORNEY

CLASS 42—(Continued).

SN 85-384,111. D2 INTERIEURS, LLC, WESTON, CT. FILED 7-28-2011.

A Home Well Styled

THE MARK CONSISTS OF STANDARD CHARACTERS WITHOUT CLAIM TO ANY PARTICULAR FONT, STYLE, SIZE, OR COLOR.

FOR CONSULTING FOR DESIGNING AND PLANNING OF INTERIOR AND EXTERIOR HOME SPACES, INCLUDING SELECTION OF FURNITURE, MATERIALS, SURFACES, AND LIGHTING; AND HOME STAGING SERVICES, NAMELY, TEMPORARY INTERIOR AND EXTERIOR HOME DECORATION CONSULTATION FOR THE PURPOSE OF MAKING HOMES MORE APPEALING TO PROSPECTIVE BUYERS (U.S. CLS. 100 AND 101).

FIRST USE 1-1-2011; IN COMMERCE 4-1-2011.
ANTHONY RINKER, EXAMINING ATTORNEY

SN 85-386,088. MPI RESEARCH, INC., MATTAWAN, MI. FILED 8-1-2011.



THE COLOR(S) GRAY IS/ARE CLAIMED AS A FEATURE OF THE MARK.

THE MARK CONSISTS OF A FLASK INSIDE OF WHICH ARE 4 FLOORS WHICH ARE CONNECTED BY A SPIRAL STAIRCASE, EACH FLOOR SHOWING INDIVIDUALS WORKING IN DIFFERENT CLINICAL SETTINGS. THE CLINICAL SETTINGS ARE, MOVING TOP TO BOTTOM, 3 INDIVIDUALS SITTING AT A TABLE, 2 INDIVIDUALS LOOKING INTO MICROSCOPES, 2 INDIVIDUALS WORKING IN A LABORATORY SETTING, AND 5 INDIVIDUALS WORKING IN A SURGICAL SETTING. THE FLASKS, STAIRCASE, AND AFOREMENTIONED SETTINGS ARE GRAY. THE BACKGROUND IS GRAY.

FOR ARRANGING AND CONDUCTING PRE-CLINICAL RESEARCH AND PRE-CLINICAL TRIALS FOR PHARMACEUTICAL, INDUSTRIAL, CHEMICAL, AGROCHEMICAL, BIOTECHNOLOGY, VETERINARY, FOOD, HEALTH CARE, AND CONSUMER COMPANIES TO ASSURE COMPLIANCE WITH FEDERAL REGULATIONS (U.S. CLS. 100 AND 101).

MICHAEL KEATING, EXAMINING ATTORNEY

CLASS 42—(Continued).

SN 85-386,107. MPI RESEARCH, INC., MATTAWAN, MI. FILED 8-1-2011.



THE MARK CONSISTS OF A FLASK INSIDE OF WHICH ARE 4 FLOORS WHICH ARE CONNECTED BY A SPIRAL STAIRCASE, EACH FLOOR SHOWING INDIVIDUALS WORKING IN DIFFERENT CLINICAL SETTINGS. THE CLINICAL SETTINGS ARE, MOVING TOP TO BOTTOM, 3 INDIVIDUALS SITTING AT A TABLE, 2 INDIVIDUALS LOOKING INTO MICROSCOPES, 2 INDIVIDUALS WORKING IN A LABORATORY SETTING, AND 5 INDIVIDUALS WORKING IN A SURGICAL SETTING.

FOR ARRANGING AND CONDUCTING PRE-CLINICAL RESEARCH AND PRE-CLINICAL TRIALS FOR PHARMACEUTICAL, INDUSTRIAL, CHEMICAL, AGROCHEMICAL, BIOTECHNOLOGY, VETERINARY, FOOD, HEALTH CARE, AND CONSUMER COMPANIES TO ASSURE COMPLIANCE WITH FEDERAL REGULATIONS (U.S. CLS. 100 AND 101).

FIRST USE 5-0-2010; IN COMMERCE 5-0-2010.
MICHAEL KEATING, EXAMINING ATTORNEY

SN 85-386,121. MPI RESEARCH, INC., MATTAWAN, MI. FILED 8-1-2011.



THE COLOR(S) GRAY, WHITE, DARK BLUE, BLUE, ORANGE AND SILVER IS/ARE CLAIMED AS A FEATURE OF THE MARK.

THE MARK CONSISTS OF A ORANGE AND GRAY FLASK INSIDE OF WHICH ARE 4 FLOORS WHICH ARE CONNECTED BY A GRAY AND SILVER SPIRAL STAIRCASE, EACH FLOOR SHOWING INDIVIDUALS WORKING IN DIFFERENT CLINICAL SETTINGS. THE CLINICAL SETTINGS ARE, MOVING TOP TO BOTTOM, 3 INDIVIDUALS IN DARK BLUE SUITS SITTING AT A GRAY

CLASS 42—(Continued).

TABLE, 2 INDIVIDUALS IN WHITE COATS AND DARK BLUE PANTS LOOKING INTO GRAY MICROSCOPES WITH A GRAY AND BLUE DISPLAY SCREEN, 2 INDIVIDUALS WORKING IN A LABORATORY SETTING WITH WHITE COATS AND DARK BLUE PANTS WITH SILVER, GRAY AND BLUE EQUIPMENT, AND 5 INDIVIDUALS WORKING IN A SURGICAL SETTING IN BLUE AND DARK BLUE SCRUB SUITS WITH A GRAY FLOOR, WHITE LIGHT AND GRAY, SILVER AND BLUE EQUIPMENT. THE BACKGROUND IS ORANGE.

FOR ARRANGING AND CONDUCTING PRE-CLINICAL RESEARCH AND PRE-CLINICAL TRIALS FOR PHARMACEUTICAL, INDUSTRIAL, CHEMICAL, AGROCHEMICAL, BIOTECHNOLOGY, VETERINARY, FOOD, HEALTH CARE, AND CONSUMER COMPANIES TO ASSURE COMPLIANCE WITH FEDERAL REGULATIONS (U.S. CLS. 100 AND 101).

FIRST USE 5-0-2010; IN COMMERCE 5-0-2010.

MICHAEL KEATING, EXAMINING ATTORNEY

SN 85-386,137. MPI RESEARCH, INC., MATTAWAN, MI.
FILED 8-1-2011.



THE COLOR(S) GRAY, WHITE, DARK BLUE, BLUE, GRAY-BLUE AND SILVER IS/ARE CLAIMED AS A FEATURE OF THE MARK.

THE MARK CONSISTS OF A GRAY-BLUE AND GRAY FLASK INSIDE OF WHICH ARE 4 FLOORS WHICH ARE CONNECTED BY A GRAY AND SILVER SPIRAL STAIRCASE. EACH FLOOR SHOWING INDIVIDUALS WORKING IN DIFFERENT CLINICAL SETTINGS. THE CLINICAL SETTINGS ARE, MOVING TOP TO BOTTOM, 3 INDIVIDUALS IN DARK BLUE SUITS SITTING AT A GRAY TABLE, 2 INDIVIDUALS IN WHITE COATS AND DARK BLUE PANTS LOOKING INTO GRAY MICROSCOPES WITH A GRAY AND BLUE DISPLAY SCREEN, 2 INDIVIDUALS WORKING IN A LABORATORY SETTING WITH WHITE COATS AND DARK BLUE PANTS WITH SILVER, GRAY AND BLUE EQUIPMENT, AND 5 INDIVIDUALS WORKING IN A SURGICAL SETTING IN BLUE AND DARK BLUE SCRUB SUITS WITH A GRAY FLOOR, WHITE LIGHT AND GRAY, SILVER AND BLUE EQUIPMENT. THE FLASK HAS A BLUE AND GRAY-BLUE SHADOW EXTENDING OUTWARD FROM THE BOTTOM LEFT OF THE FLASK.

FOR ARRANGING AND CONDUCTING PRE-CLINICAL RESEARCH AND PRE-CLINICAL TRIALS FOR PHARMACEUTICAL, INDUSTRIAL, CHEMICAL, AGROCHEMICAL, BIOTECHNOLOGY, VETERINARY, FOOD, HEALTH CARE, AND CONSUMER COMPANIES TO ASSURE COMPLIANCE WITH FEDERAL REGULATIONS (U.S. CLS. 100 AND 101).

FIRST USE 5-0-2010; IN COMMERCE 5-0-2010.

MICHAEL KEATING, EXAMINING ATTORNEY

CLASS 42—(Continued).

SN 85-394,679. INFIELD SALES/PRO LLC, FAIRFIELD, NJ.
FILED 8-10-2011.

MOBILEPRO3

THE MARK CONSISTS OF STANDARD CHARACTERS WITHOUT CLAIM TO ANY PARTICULAR FONT, STYLE, SIZE, OR COLOR.

FOR SOFTWARE AS A SERVICE, NAMELY, PROVIDING ON-LINE NON-DOWNLOADABLE SOFTWARE FOR MANAGING CUSTOMER RELATIONSHIP INFORMATION, IN THE FIELDS OF SALES AND MARKETING (U.S. CLS. 100 AND 101).

PATRICIA EVANKO, EXAMINING ATTORNEY

SN 85-395,180. AASKI TECHNOLOGY, INC., OCEAN, NJ.
FILED 8-11-2011.

**Mission Focused, Customer
Centric**

THE MARK CONSISTS OF STANDARD CHARACTERS WITHOUT CLAIM TO ANY PARTICULAR FONT, STYLE, SIZE, OR COLOR.

NO CLAIM IS MADE TO THE EXCLUSIVE RIGHT TO USE "CUSTOMER CENTRIC", APART FROM THE MARK AS SHOWN.

FOR DESIGN FOR OTHERS IN THE FIELD OF COMPUTER NETWORKS, SOFTWARE, AND ENGINEERING FOR THE DEPARTMENT OF DEFENSE (U.S. CLS. 100 AND 101).

FIRST USE 7-1-2011; IN COMMERCE 7-1-2011.

ZACHARY BELLO, EXAMINING ATTORNEY

SN 85-398,034. COLLEGE OF AMERICAN PATHOLOGISTS,
NORTHFIELD, IL. FILED 8-15-2011.

**CAP ACCREDITATION
READINESS ASSESSMENT**

THE MARK CONSISTS OF STANDARD CHARACTERS WITHOUT CLAIM TO ANY PARTICULAR FONT, STYLE, SIZE, OR COLOR.

OWNER OF U.S. REG. NOS. 3,479,635, 3,819,547 AND OTHERS.

NO CLAIM IS MADE TO THE EXCLUSIVE RIGHT TO USE "ACCREDITATION READINESS ASSESSMENT", APART FROM THE MARK AS SHOWN.

FOR TESTING, ANALYSIS AND EVALUATION OF THE GOODS AND SERVICES OF OTHERS FOR THE PURPOSE OF CERTIFICATION (U.S. CLS. 100 AND 101).

FIRST USE 7-21-2010; IN COMMERCE 7-21-2010.

ESTHER A. BORSUK, EXAMINING ATTORNEY

CLASS 42—(Continued).

SN 85-403,052. SCHAFFER, STEFAN, EGGENSTEIN-LEO-POLDSHAF, FED REP GERMANY, FILED 8-20-2011.

GLOOOBAL

THE MARK CONSISTS OF STANDARD CHARACTERS WITHOUT CLAIM TO ANY PARTICULAR FONT, STYLE, SIZE, OR COLOR.

FOR COMPUTER SERVICES, NAMELY, ON-SITE MANAGEMENT OF INFORMATION TECHNOLOGY (IT) SYSTEMS; COMPUTER SERVICES, NAMELY, REMOTE MANAGEMENT OF THE INFORMATION TECHNOLOGY (IT) SYSTEMS OF OTHERS; COMPUTER SOFTWARE DEVELOPMENT; COMPUTER SOFTWARE DEVELOPMENT AND COMPUTER PROGRAMMING DEVELOPMENT FOR OTHERS; COMPUTER SOFTWARE DEVELOPMENT IN THE FIELD OF MOBILE APPLICATIONS; COMPUTER TECHNICAL SUPPORT SERVICES, NAMELY, 24/7 SERVICE DESK/HELP DESK SERVICES FOR IT INFRASTRUCTURE, OPERATING SYSTEMS, DATABASE SYSTEMS, AND WEB APPLICATIONS, IT CONSULTING SERVICES; IT INTEGRATION SERVICES; TECHNICAL SUPPORT SERVICES, NAMELY, REMOTE AND ON-SITE INFRASTRUCTURE MANAGEMENT SERVICES FOR MONITORING, ADMINISTRATION AND MANAGEMENT OF PUBLIC AND PRIVATE CLOUD COMPUTING IT AND APPLICATION SYSTEMS (U.S. CLS. 100 AND 101).

ANNE MADDEN, EXAMINING ATTORNEY

SN 85-404,896. EADOPT, LLC, DAVIDSON, NC. FILED 8-23-2011.



NO CLAIM IS MADE TO THE EXCLUSIVE RIGHT TO USE "EADOPT", APART FROM THE MARK AS SHOWN.

THE COLOR(S) BLUE IS/ARE CLAIMED AS A FEATURE OF THE MARK.

THE MARK CONSISTS OF THE LITERAL ELEMENTS "EADOPT" WRITTEN IN BLUE COLOR TO THE LEFT OF WHICH THERE IS AN IMAGE OF FOUR BALLOON LIKE STRUCTURES IN BLUE COLOR PLACED OVER ONE OTHER RESPECTIVELY IN SUCH A WAY AS THE POINTED PORTION OF EACH IMAGE LIE OVER THE OTHER AS SHOWN IN THE MARK.

FOR COMPUTER SOFTWARE SERVICES, NAMELY, PROVIDING A WEB-BASED SYSTEM AND ONLINE PORTAL FEATURING ONLINE NON-DOWNLOADABLE SOFTWARE THAT ENABLES REGISTERED ADOPTION AGENCIES TO MANAGE ADOPTION PROCESS AND SHARE PROCESS, CHECKLISTS AND DOCUMENTS WITH REGISTERED CLIENTS (U.S. CLS. 100 AND 101).

FIRST USE 5-11-2010; IN COMMERCE 9-9-2010.

STEVEN R. FINE, EXAMINING ATTORNEY

CLASS 42—(Continued).

SN 85-417,392. ASPIRE ALLIANCE LLC, DBA TRUSTNET, ATLANTA, GA. FILED 9-8-2011.

ITRUST

THE MARK CONSISTS OF STANDARD CHARACTERS WITHOUT CLAIM TO ANY PARTICULAR FONT, STYLE, SIZE, OR COLOR.

FOR COMPUTER SERVICES, NAMELY, ASSESSING, AUDITING, MONITORING, AND REPORTING SECURITY AND COMPLIANCE RISKS IN COMPUTER NETWORKS (U.S. CLS. 100 AND 101).

FIRST USE 10-2-2010; IN COMMERCE 10-2-2010.

STEVEN R. FINE, EXAMINING ATTORNEY

SN 85-417,852. HELIAE DEVELOPMENT, LLC, GILBERT, AZ. FILED 9-8-2011.

FOOD, FUEL, FOREVER.

THE MARK CONSISTS OF STANDARD CHARACTERS WITHOUT CLAIM TO ANY PARTICULAR FONT, STYLE, SIZE, OR COLOR.

FOR PRODUCT RESEARCH AND DEVELOPMENT IN THE FIELD OF MANUFACTURING, EXTRACTING, HYDROTREATING, MEASURING, CONTROLLING AND REFINING FUELS, HIGH VALUE NUTRACEUTICAL PRODUCTS AND CHEMICALS FROM ALGAE AND LIGHT CAPTURE PHOTOBIOREACTORS (U.S. CLS. 100 AND 101).

NANCY CLARKE, EXAMINING ATTORNEY

SN 85-418,954. VALIDAR INC, SEATTLE, WA. FILED 9-9-2011.

EventHub

THE MARK CONSISTS OF STANDARD CHARACTERS WITHOUT CLAIM TO ANY PARTICULAR FONT, STYLE, SIZE, OR COLOR.

FOR COMPUTER SERVICES, NAMELY, HOSTING AN INTERACTIVE WEB SITE THAT ALLOWS EVENT MARKETERS TO CONNECT TO THEIR ATTENDEES PRIOR, DURING AND AFTER AN EVENT BY ENABLING FEATURES OF REGISTRATION, SURVEY FEEDBACK, SCHEDULES, EXCHANGE OF CONTACT INFORMATION BETWEEN ATTENDEES (U.S. CLS. 100 AND 101).

DAVID TAYLOR, EXAMINING ATTORNEY

CLASS 42—(Continued).

SN 85-421,245. NETEFFECT NETWORKS, INC., LAS VEGAS, NV. FILED 9-13-2011.

MyGrid ANYWHERE COMPUTING

THE MARK CONSISTS OF STANDARD CHARACTERS WITHOUT CLAIM TO ANY PARTICULAR FONT, STYLE, SIZE, OR COLOR.

OWNER OF U.S. REG. NO. 4,049,277.

NO CLAIM IS MADE TO THE EXCLUSIVE RIGHT TO USE "COMPUTING", APART FROM THE MARK AS SHOWN.

FOR PROVIDING VIRTUAL COMPUTER SYSTEMS AND VIRTUAL COMPUTER ENVIRONMENTS THROUGH CLOUD COMPUTING (U.S. CLS. 100 AND 101).

FIRST USE 12-1-2010; IN COMMERCE 12-1-2010.
SKYE YOUNG, EXAMINING ATTORNEY

SN 85-421,265. MICRO SYSTEMS MANAGEMENT COMPANY, INC., WESTLAKE, OH. FILED 9-13-2011.

ProSysCtrl

THE MARK CONSISTS OF STANDARD CHARACTERS WITHOUT CLAIM TO ANY PARTICULAR FONT, STYLE, SIZE, OR COLOR.

FOR COMPUTER SERVICES, NAMELY, COMPUTER SYSTEM ADMINISTRATION FOR OTHERS; COMPUTER SERVICES, NAMELY, DATA RECOVERY SERVICES; COMPUTER SERVICES, NAMELY, INTEGRATION OF COMPUTER SOFTWARE INTO MULTIPLE SYSTEMS AND NETWORKS; COMPUTER SERVICES, NAMELY, INTEGRATION OF PRIVATE AND PUBLIC CLOUD COMPUTING ENVIRONMENTS; COMPUTER SERVICES, NAMELY, MONITORING AND REPORTING ON THE PERFORMANCE, AVAILABILITY, AND ERRORS OF WEB SITES OF OTHERS; COMPUTER SERVICES, NAMELY, ON-LINE SCANNING, DETECTING, QUARANTINING AND ELIMINATING OF VIRUSES, WORMS, TROJANS, SPYWARE, ADWARE, MALWARE AND UNAUTHORIZED DATA AND PROGRAMS ON COMPUTERS AND ELECTRONIC DEVICES; COMPUTER SERVICES, NAMELY, ON-SITE MANAGEMENT OF INFORMATION TECHNOLOGY (IT) SYSTEMS; COMPUTER SERVICES, NAMELY, PROVIDING VIRTUAL AND NON VIRTUAL APPLICATION SERVERS, WEB SERVERS, FILE SERVERS, CO-LOCATION SERVERS, LOAD BALANCING SERVERS, REDUNDANCY SERVERS, MEDIA SERVERS AND DATABASE SERVERS OF VARIABLE CAPACITY TO THIRD PARTY COMPUTING AND DATA STORAGE FACILITIES; COMPUTER SERVICES, NAMELY, REMOTE AND ON-SITE MANAGEMENT OF ELECTRONIC MAIL SERVER OF OTHERS; COMPUTER SERVICES, NAMELY, REMOTE MANAGEMENT OF THE INFORMATION TECHNOLOGY (IT) SYSTEMS OF OTHERS; COMPUTER SERVICES, NAMELY, REMOTE MANAGEMENT OF DATA SERVER FOR OTHERS (U.S. CLS. 100 AND 101).

FIRST USE 9-12-2011; IN COMMERCE 9-12-2011.
ELLEN PERKINS, EXAMINING ATTORNEY

CLASS 42—(Continued).

SN 85-421,792. BBH CONSULTING, INC., CLEARFIELD, UT. FILED 9-13-2011.



NO CLAIM IS MADE TO THE EXCLUSIVE RIGHT TO USE "CONSULTING", APART FROM THE MARK AS SHOWN.

THE COLOR(S) BLUE AND RED IS/ARE CLAIMED AS A FEATURE OF THE MARK.

THE MARK CONSISTS OF THE LETTERS "BBH", IN BLUE AND RED, IN STYLIZED FORM, ABOVE THE WORD "CONSULTING", WHICH IS IN BLUE.

FOR ENGINEERING SERVICES IN THE FIELDS OF DATA ANALYSIS, DEPOT LOGISTICS, SUPPLY CHAIN MANAGEMENT, DEPOT REPAIR, PRODUCT MANAGEMENT, PROGRAM MANAGEMENT, PROCESS MODELING, AEROSPACE, AND WEAPONRY; PRODUCT DEVELOPMENT AND ENGINEERING SERVICES FOR OTHERS IN THE FIELDS OF PRODUCT MANAGEMENT, PROGRAM MANAGEMENT, DEPOT LOGISTICS, SUPPLY CHAIN MANAGEMENT, DEPOT REPAIR, PROCESS MODELING, AEROSPACE, AND WEAPONRY; PLANNING AND DESIGN OF AEROSPACE MAINTENANCE FACILITIES; PLANNING, DESIGN AND MANAGEMENT OF INFORMATION TECHNOLOGY SYSTEMS; TECHNOLOGICAL SERVICES, NAMELY, RESEARCH, ANALYSIS, AND TESTING, IN THE FIELDS OF DEPOT LOGISTICS, SUPPLY CHAIN MANAGEMENT, DEPOT REPAIR, PRODUCT MANAGEMENT, PROGRAM MANAGEMENT, PROCESS MODELING, AEROSPACE, AND WEAPONRY; TESTING, ANALYSIS, AND EVALUATION OF AEROSPACE SYSTEMS AND WEAPONRY SYSTEMS; DESIGN FOR OTHERS IN THE FIELD OF ENGINEERING FOR THE PRODUCT MANAGEMENT, PROGRAM MANAGEMENT, PROCESS MODELING, AEROSPACE, AND WEAPONRY INDUSTRIES; DATA MINING (U.S. CLS. 100 AND 101).

FIRST USE 1-1-2011; IN COMMERCE 1-1-2011.
STEPHANIE ALI, EXAMINING ATTORNEY

CLASS 42—(Continued).

SN 85-423,217. HARRIS CORPORATION, MELBOURNE, FL.
FILED 9-15-2011.

PEAKE HEALTHCARE INNOVATIONS

THE MARK CONSISTS OF STANDARD CHARACTERS WITHOUT CLAIM TO ANY PARTICULAR FONT, STYLE, SIZE, OR COLOR.

NO CLAIM IS MADE TO THE EXCLUSIVE RIGHT TO USE "HEALTHCARE", APART FROM THE MARK AS SHOWN.

FOR CLOUD COMPUTING SERVICES FEATURING SOFTWARE FOR USE IN THE ACCESSING AND RETRIEVAL OF REMOTELY STORED DATA IN THE NATURE OF MEDICAL IMAGES; SOFTWARE AS A SERVICE (SAAS) SERVICES FEATURING SOFTWARE FOR USE IN MANAGING MEDICAL IMAGES; PROVIDING TEMPORARY USE OF ON-LINE NON-DOWNLOADABLE SOFTWARE FOR MANAGING MEDICAL IMAGES (U.S. CLS. 100 AND 101).

AMY ALFIERI, EXAMINING ATTORNEY

CLASS 42—(Continued).

SN 85-432,568. QUICK RESPONSE HOLDINGS, LLC, DBA
SCANSOLD, SAN DIEGO, CA. FILED 9-27-2011.

ScanSold

THE MARK CONSISTS OF STANDARD CHARACTERS WITHOUT CLAIM TO ANY PARTICULAR FONT, STYLE, SIZE, OR COLOR.

FOR PROVIDING A WEB HOSTING PLATFORM FOR MOBILE DEVICE WEBSITES TO ENABLE USERS TO CREATE AND MANAGE WEBSITES; PROVIDING A WEB SITE FEATURING TECHNOLOGY THAT ENABLES USERS TO CREATE AND MANAGE MOBILE DEVICE WEBSITES (U.S. CLS. 100 AND 101).

FIRST USE 8-1-2011; IN COMMERCE 8-1-2011.

WON TEAK OH, EXAMINING ATTORNEY

SN 85-433,367. INTEGRATED SERVICE PARTNERS LTD.,
CHICAGO, IL. FILED 9-27-2011.

CloudServe

THE MARK CONSISTS OF STANDARD CHARACTERS WITHOUT CLAIM TO ANY PARTICULAR FONT, STYLE, SIZE, OR COLOR.

FOR IT CONSULTING SERVICES (U.S. CLS. 100 AND 101).

FIRST USE 9-1-2011; IN COMMERCE 9-1-2011.

MATTHEW MCDOWELL, EXAMINING ATTORNEY

SN 85-431,278. BABY DIMENSIONS LLC, NEWNAN, GA.
FILED 9-24-2011.



NO CLAIM IS MADE TO THE EXCLUSIVE RIGHT TO USE "BABY", APART FROM THE MARK AS SHOWN.

THE STIPPLING IS FOR SHADING PURPOSES ONLY.

THE MARK CONSISTS OF 4 HALF ARCS ON TOP OF TWO BABY FEET, WITH THE WORDS "BABY DIMENSIONS" UNDER THE FEET.

FOR NON-MEDICAL, ULTRASOUND IMAGING SERVICES (U.S. CLS. 100 AND 101).

FIRST USE 7-10-2007; IN COMMERCE 7-10-2007.

JAMES A. RAUEN, EXAMINING ATTORNEY

SN 85-433,745. INDUSTRY STANDARD DESIGN LAB, LLC,
OLATHE, KS. FILED 9-28-2011.

Lendle

THE MARK CONSISTS OF STANDARD CHARACTERS WITHOUT CLAIM TO ANY PARTICULAR FONT, STYLE, SIZE, OR COLOR.

OWNER OF U.S. REG. NO. 4,025,804.

FOR PROVIDING AN ONLINE NON-DOWNLOADABLE INTERNET-BASED SYSTEM APPLICATION FEATURING TECHNOLOGY ENABLING USERS TO LIST OWNED ELECTRONIC BOOKS AND IDENTIFY OTHER ELECTRONIC BOOKS OWNED BY OTHER USERS, THUS CREATING A SHARING ENVIRONMENT FOR THE LENDING AND BORROWING OF ELECTRONIC BOOKS (U.S. CLS. 100 AND 101).

FIRST USE 1-27-2011; IN COMMERCE 1-27-2011.

JEFFREY LOOK, EXAMINING ATTORNEY

CLASS 42—(Continued).

SN 85-435,109. NOVALINK SOLUTIONS, LLC, DULUTH, GA. FILED 9-29-2011.

NOVALINK

THE MARK CONSISTS OF STANDARD CHARACTERS WITHOUT CLAIM TO ANY PARTICULAR FONT, STYLE, SIZE, OR COLOR.

FOR CONSULTING IN THE FIELDS OF INFORMATION TECHNOLOGY AND TELECOMMUNICATIONS TECHNOLOGY; PROVIDING ENGINEERING SERVICES IN THE FIELDS OF INFORMATION TECHNOLOGY AND TELECOMMUNICATIONS (U.S. CLS. 100 AND 101).

FIRST USE 7-21-2003; IN COMMERCE 7-21-2003.
AMY KERTGATE, EXAMINING ATTORNEY

CLASS 42—(Continued).

SN 85-437,410. DR. CHARLES BLAIR & ASSOCIATES, INC., MOUNT HOLLY, NC. FILED 10-3-2011.

PRACTICE BOOSTER

THE MARK CONSISTS OF STANDARD CHARACTERS WITHOUT CLAIM TO ANY PARTICULAR FONT, STYLE, SIZE, OR COLOR.

OWNER OF U.S. REG. NO. 3,162,176.

NO CLAIM IS MADE TO THE EXCLUSIVE RIGHT TO USE "PRACTICE", APART FROM THE MARK AS SHOWN.

FOR PROVIDING ON-LINE NON-DOWNLOADABLE SOFTWARE FOR DENTISTS WHICH ALLOWS A DENTAL OFFICE TO LOOK UP INSURANCE CODES FOR DENTAL AND MEDICAL INSURANCE CLAIMS; PROVIDING ON-LINE NON-DOWNLOADABLE SOFTWARE FOR DENTISTS WHICH ASSISTS A DENTAL OFFICE IN COMPLETING AND FILING DENTAL AND MEDICAL INSURANCE CLAIMS; PROVIDING ON-LINE NON-DOWNLOADABLE SOFTWARE FOR DENTAL OFFICE PRACTICE MANAGEMENT (U.S. CLS. 100 AND 101).

FIRST USE 9-15-2011; IN COMMERCE 9-15-2011.
MICHELE SWAIN, EXAMINING ATTORNEY

SN 85-435,509. NCH SOFTWARE, GREENWOOD VILLAGE, CO. FILED 9-29-2011.



The logo consists of the letters "NCH" in a bold, black, sans-serif font. The letter "C" is red and is positioned between the "N" and "H". Below "NCH" is the word "Software" in a smaller, black, sans-serif font.

NCH Software

NO CLAIM IS MADE TO THE EXCLUSIVE RIGHT TO USE "SOFTWARE", APART FROM THE MARK AS SHOWN. THE COLOR(S) RED AND BLACK IS/ARE CLAIMED AS A FEATURE OF THE MARK.

THE MARK CONSISTS OF THE LETTERS "NCH" ABOVE "NCH SOFTWARE". THE TOP LETTER "C" IS RED AND SUPERIMPOSED ACROSS THE LETTERS "NH". THE REST OF THE LETTERING IS BLACK.

FOR DESIGN AND DEVELOPMENT OF COMPUTER HARDWARE AND SOFTWARE; UPDATING OF COMPUTER SOFTWARE FOR OTHERS (U.S. CLS. 100 AND 101).

FIRST USE 3-1-1993; IN COMMERCE 3-1-1993.
IRA J. GOODSAD, EXAMINING ATTORNEY

SN 85-437,522. LYNCH, JOHNNY, MCKINNEY, TX. AND BARNES, MARCUS, MCKINNEY, TX. FILED 10-3-2011.

craniumsoft

THE MARK CONSISTS OF STANDARD CHARACTERS WITHOUT CLAIM TO ANY PARTICULAR FONT, STYLE, SIZE, OR COLOR.

FOR SOFTWARE AS A SERVICE (SAAS) SERVICES FEATURING SOFTWARE FOR BUSINESSES TO PROMOTE EXCLUSIVE PURCHASING OF GOODS AND SERVICES THROUGH NON-PROFIT AND COMMUNITY BASED GROUPS AND THE BUSINESSES PAY MONETARY COMMISSIONS TO THESE GROUPS BASED UPON RESULTING PURCHASES (U.S. CLS. 100 AND 101).

FIRST USE 2-11-2009; IN COMMERCE 8-9-2010.
EDWARD NELSON, EXAMINING ATTORNEY

CLASS 42—(Continued).

SN 85-441,893. PEGASYSTEMS INC., CAMBRIDGE, MA. FILED 10-7-2011.

PEGA CLOUD

THE MARK CONSISTS OF STANDARD CHARACTERS WITHOUT CLAIM TO ANY PARTICULAR FONT, STYLE, SIZE, OR COLOR.

OWNER OF U.S. REG. NOS. 2,799,071, 2,905,104 AND 3,247,526.

NO CLAIM IS MADE TO THE EXCLUSIVE RIGHT TO USE "CLOUD", APART FROM THE MARK AS SHOWN.

FOR PROVIDING ON-LINE NON-DOWNLOADABLE SOFTWARE FOR BUSINESS PROCESS MANAGEMENT (BPM) AND CUSTOMER RELATIONSHIP MANAGEMENT (CRM); PLATFORM AS A SERVICE (PAAS) FEATURING A COMPUTER SOFTWARE PLATFORM FOR BUSINESS PROCESS MANAGEMENT AND CUSTOMER RELATIONSHIP MANAGEMENT; PROVIDING ON-LINE NON-DOWNLOADABLE SOFTWARE FOR CREATING, MAINTAINING AND LINKING DATABASES OF INFORMATION RELATING TO CUSTOMERS, SUPPLIERS AND OTHER BUSINESS CONTACTS; PROVIDING ON-LINE NON-DOWNLOADABLE SOFTWARE FOR MANAGING CUSTOMER SERVICE REQUESTS; PROVIDING ON-LINE NON-DOWNLOADABLE SOFTWARE FOR ROUTING CUSTOMER INQUIRIES TO THE APPROPRIATE PERSONNEL AND FOR PRIORITIZING THE WORK RESULTING FROM SUCH INQUIRIES; PROVIDING ON-LINE NON-DOWNLOADABLE SOFTWARE FOR AUTOMATICALLY RETRIEVING AND ANALYZING INFORMATION REQUIRED TO RESPOND TO CUSTOMER INQUIRIES; PROVIDING ON-LINE NON-DOWNLOADABLE SOFTWARE FOR AUTOMATICALLY GENERATING COMMUNICATIONS IN RESPONSE TO CUSTOMER INQUIRIES; PROVIDING ON-LINE NON-DOWNLOADABLE SOFTWARE FOR RESOLVING CUSTOMER-RELATED ISSUES BY REFERENCE TO APPROPRIATE BUSINESS RULES; PROVIDING ON-LINE NON-DOWNLOADABLE SOFTWARE FOR MANAGING TELEPHONE CALL CENTERS; PROVIDING ON-LINE NON-DOWNLOADABLE SOFTWARE FOR INTEGRATING CUSTOMER DATA AND CONTACT INFORMATION FROM A VARIETY OF DIFFERENT SOURCES; PROVIDING ON-LINE NON-DOWNLOADABLE SOFTWARE FOR BUSINESS WORKFLOW AUTOMATION; COMPUTER SOFTWARE CONSULTATION, NAMELY, CONSULTATION IN THE FIELD OF BUSINESS PROCESS MANAGEMENT SOFTWARE; COMPUTER SYSTEM CONFIGURATION AND ANALYSIS; COMPUTER SYSTEMS INTEGRATION SERVICES; TECHNICAL SUPPORT SERVICES, NAMELY, TROUBLESHOOTING OF COMPUTER SOFTWARE PROBLEMS; INFORMATION TECHNOLOGY CONSULTATION (U.S. CLS. 100 AND 101).

FIRST USE 0-0-2010; IN COMMERCE 0-0-2010.

EMILY CARLSEN, EXAMINING ATTORNEY

CLASS 42—(Continued).

SN 85-442,479. STRATECH, INC., CARY, NC. FILED 10-7-2011.



NO CLAIM IS MADE TO THE EXCLUSIVE RIGHT TO USE "TECH", APART FROM THE MARK AS SHOWN.

THE MARK CONSISTS OF THE LITERAL ELEMENT "STRATECH" APPEARING IN A STYLIZED FONT TO THE RIGHT OF AND ADJACENT TO A STYLIZED CIRCULAR DESIGN ELEMENT RESEMBLING A GLOBE WITH MERIDIANS AND PARALLELS

FOR COMPUTER SYSTEM DESIGN AND INTEGRATION FOR OTHERS; APPLICATION SERVICE PROVIDER, NAMELY, PROVIDING HOSTING, MANAGING, AND MAINTAINING SOFTWARE AND DATABASES FOR OTHERS; INFORMATION TECHNOLOGY SECURITY CONSULTING SERVICES; MONITORING OF NETWORK SYSTEMS, AND PROVIDING BACK-UP COMPUTER PROGRAMS AND FACILITIES; COMPUTER COLOCATION SERVICES, NAMELY, PROVIDING FACILITIES FOR THE LOCATION OF COMPUTER SERVERS WITH THE EQUIPMENT OF OTHERS; COMPUTER SERVICES, NAMELY, REMOTE AND ON-SITE MANAGEMENT OF THE INFORMATION TECHNOLOGY (IT) SYSTEMS OF OTHERS; AND IT CONSULTING SERVICES; AND IT INTEGRATION SERVICES (U.S. CLS. 100 AND 101).

DOMINIC J. FERRAIUOLO, EXAMINING ATTORNEY

SN 85-444,257. DIGITACTICS, INC., SAN ANTONIO, TX. FILED 10-11-2011.

DIGITACTICS

THE MARK CONSISTS OF STANDARD CHARACTERS WITHOUT CLAIM TO ANY PARTICULAR FONT, STYLE, SIZE, OR COLOR.

FOR COMPUTER AND SOFTWARE CONSULTING; COMPUTER HARDWARE AND SOFTWARE DESIGN; COMPUTER SUPPORT SERVICES, NAMELY, TROUBLESHOOTING IN THE NATURE OF DIAGNOSING COMPUTER HARDWARE AND SOFTWARE PROBLEMS; COMPUTER NETWORK SECURITY SERVICES, NAMELY, RESTRICTING ACCESS TO AND BY COMPUTER NETWORKS TO AND OF UNDESIRE WEB SITES, MEDIA AND INDIVIDUALS AND FACILITIES AND RESPONDING TO, REMEDIATING, AND INVESTIGATING SECURITY ANOMALIES; SOFTWARE APPLICATION DEVELOPMENT; DIGITAL FORENSICS SERVICES FOR COMPUTERS (U.S. CLS. 100 AND 101).

FIRST USE 2-7-2004; IN COMMERCE 2-7-2004.

MELISSA VALLILLO, EXAMINING ATTORNEY

CLASS 42—(Continued).

SN 85-444,757. CSG SYSTEMS, INC., ENGLEWOOD, CO.
FILED 10-11-2011.

PRECISION EMAIL

THE MARK CONSISTS OF STANDARD CHARACTERS WITHOUT CLAIM TO ANY PARTICULAR FONT, STYLE, SIZE, OR COLOR.

NO CLAIM IS MADE TO THE EXCLUSIVE RIGHT TO USE "EMAIL", APART FROM THE MARK AS SHOWN.

FOR APPLICATION SERVICE PROVIDER FEATURING SOFTWARE FOR PREPARATION OF CUSTOMIZED TRANSACTIONAL AND COMMERCIAL ELECTRONIC MAIL COMMUNICATIONS WITH ENCRYPTED OR UNENCRYPTED ATTACHMENTS TAILORED TO EACH RECIPIENT BASED ON CUSTOMER PROFILE DATA, SUCH AS ACCOUNT STATUS, ORDER AND PAYMENT HISTORY, CUSTOMER DEMOGRAPHICS AND OTHER CRITERIA SPECIFIC TO EACH CUSTOMER; APPLICATION SERVICE PROVIDER FEATURING SOFTWARE FOR TRACKING AND REPORTING EFFECTIVENESS OF MESSAGES DELIVERED VIA ELECTRONIC MAIL (U.S. CLS. 100 AND 101).

FIRST USE 10-1-2009; IN COMMERCE 10-1-2009.
ANDREW LEASER, EXAMINING ATTORNEY

SN 85-444,780. CSG SYSTEMS, INC., ENGLEWOOD, CO.
FILED 10-11-2011.

PRECISION EMARKETING

THE MARK CONSISTS OF STANDARD CHARACTERS WITHOUT CLAIM TO ANY PARTICULAR FONT, STYLE, SIZE, OR COLOR.

NO CLAIM IS MADE TO THE EXCLUSIVE RIGHT TO USE "EMARKETING", APART FROM THE MARK AS SHOWN.

FOR APPLICATION SERVICE PROVIDER FEATURING SOFTWARE FOR OPTIMALLY CONVERTING PAPER-BASED ADVERTISING TO ELECTRONIC COMMUNICATION CHANNELS AND ALLOWING FOR THE MANAGEMENT OF THE DELIVERY OF ADVERTISING THROUGH VARIOUS ELECTRONIC COMMUNICATION CHANNELS; APPLICATION SERVICE PROVIDER FEATURING SOFTWARE FOR TRACKING AND REPORTING EFFECTIVENESS OF ADVERTISING DELIVERED VIA ELECTRONIC COMMUNICATION CHANNELS (U.S. CLS. 100 AND 101).

FIRST USE 10-1-2009; IN COMMERCE 10-1-2009.
ANDREW LEASER, EXAMINING ATTORNEY

CLASS 42—(Continued).

SN 85-444,789. CSG SYSTEMS, INC., ENGLEWOOD, CO.
FILED 10-11-2011.

PRECISION ECOMMERCE

THE MARK CONSISTS OF STANDARD CHARACTERS WITHOUT CLAIM TO ANY PARTICULAR FONT, STYLE, SIZE, OR COLOR.

NO CLAIM IS MADE TO THE EXCLUSIVE RIGHT TO USE "ECOMMERCE", APART FROM THE MARK AS SHOWN.

FOR APPLICATION SERVICE PROVIDER FEATURING SOFTWARE ALLOWING CUSTOMERS TO PERFORM CUSTOMER CARE FUNCTIONS VIA A GLOBAL COMPUTER NETWORK SITE, NAMELY, PRODUCT OR SERVICE REQUESTS AND PROVISIONING, OBTAINING SERVICE UPGRADES AND TECHNICIAN SCHEDULING (U.S. CLS. 100 AND 101).

FIRST USE 10-1-2009; IN COMMERCE 10-1-2009.
ANDREW LEASER, EXAMINING ATTORNEY

SN 85-444,803. CSG SYSTEMS, INC., ENGLEWOOD, CO.
FILED 10-11-2011.

PRECISION EBPP

THE MARK CONSISTS OF STANDARD CHARACTERS WITHOUT CLAIM TO ANY PARTICULAR FONT, STYLE, SIZE, OR COLOR.

NO CLAIM IS MADE TO THE EXCLUSIVE RIGHT TO USE "EBPP", APART FROM THE MARK AS SHOWN.

FOR APPLICATION SERVICE PROVIDER FEATURING SOFTWARE FOR ELECTRONIC PRESENTMENT AND/OR PROCESSING OF BILLS, TRANSMISSION OF BILL PAYMENT DATA AND CUSTOMER ACCOUNT MANAGEMENT; APPLICATION SERVICE PROVIDER FEATURING SOFTWARE FOR PROVIDING ELECTRONIC PROCESSING OF ONE-TIME AND RECURRING PAYMENTS BY SUCH METHODS AS AUTOMATED CLEARING HOUSE (ACH), DEBIT/CREDIT CARD TRANSACTIONS AND ELECTRONIC PAYMENTS VIA A GLOBAL COMPUTER NETWORK (U.S. CLS. 100 AND 101).

FIRST USE 10-1-2009; IN COMMERCE 10-1-2009.
ANDREW LEASER, EXAMINING ATTORNEY

SN 85-444,864. MONTRUE TECHNOLOGIES, INC., ASHLAND, OR. FILED 10-11-2011.

MONTRUE

THE MARK CONSISTS OF STANDARD CHARACTERS WITHOUT CLAIM TO ANY PARTICULAR FONT, STYLE, SIZE, OR COLOR.

FOR COMPUTER SOFTWARE DEVELOPMENT, COMPUTER PROGRAMMING AND MAINTENANCE OF COMPUTER SOFTWARE FOR EMERGENCY SERVICES (U.S. CLS. 100 AND 101).

FIRST USE 5-12-2011; IN COMMERCE 5-12-2011.
MARIA-VICTORIA SUAREZ, EXAMINING ATTORNEY

CLASS 42—(Continued).

SN 85-444,869. AVL APLICATIVOS LTDA. - EPP, SÃO PAULO, BRAZIL, FILED 10-11-2011.

CLASS 42—(Continued).

SN 85-445,377. STUDIOV, LLC, VENICE, CA. FILED 10-12-2011.

TOP FREE GAMES - BEST APPS

THE MARK CONSISTS OF STANDARD CHARACTERS WITHOUT CLAIM TO ANY PARTICULAR FONT, STYLE, SIZE, OR COLOR.

FOR DEVELOPMENT AND CREATION OF COMPUTER SOFTWARE AND COMPUTER SOFTWARE APPLICATIONS FOR COMMUNICATION DEVICES (U.S. CLS. 100 AND 101).

RENEE MCCRAY, EXAMINING ATTORNEY



SN 85-445,005. GLOBAL ADVANT INC., MIAMI, FL. FILED 10-12-2011.

InvoiNet

THE MARK CONSISTS OF STANDARD CHARACTERS WITHOUT CLAIM TO ANY PARTICULAR FONT, STYLE, SIZE, OR COLOR.

FOR SOFTWARE AS A SERVICE (SAAS) SERVICES FEATURING SOFTWARE FOR ELECTRONIC INVOICE PRESENTMENT AND PAYMENT (U.S. CLS. 100 AND 101).

FIRST USE 6-1-2011; IN COMMERCE 6-1-2011.
SEAN CROWLEY, EXAMINING ATTORNEY

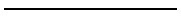

SN 85-445,233. NATIONAL ELECTRONIC ATTACHMENT, INC., NORCROSS, GA. FILED 10-12-2011.

FastAttach

THE MARK CONSISTS OF STANDARD CHARACTERS WITHOUT CLAIM TO ANY PARTICULAR FONT, STYLE, SIZE, OR COLOR.

FOR SOFTWARE AS A SERVICE (SAAS) SERVICES FEATURING SOFTWARE FOR SECURELY STORING AND SHARING ELECTRONIC INFORMATION (U.S. CLS. 100 AND 101).

FIRST USE 2-18-1998; IN COMMERCE 2-18-1998.
JAMES A. RAUEN, EXAMINING ATTORNEY

Industrial Opulence

THE MARK CONSISTS OF STANDARD CHARACTERS WITHOUT CLAIM TO ANY PARTICULAR FONT, STYLE, SIZE, OR COLOR.

FOR INTERIOR DESIGN SERVICES FEATURING HISTORICAL DESIGN AND CONTEMPORARY INTERIORS (U.S. CLS. 100 AND 101).

DORITT L. CARROLL, EXAMINING ATTORNEY

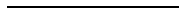

SN 85-445,392. TERRAINE, INC, RALEIGH, NC. FILED 10-12-2011.

ezCoC

THE MARK CONSISTS OF STANDARD CHARACTERS WITHOUT CLAIM TO ANY PARTICULAR FONT, STYLE, SIZE, OR COLOR.

FOR PROVIDING AN ONLINE NON-DOWNLOADABLE INTERNET-BASED SYSTEM APPLICATION FEATURING TECHNOLOGY ENABLING USERS TO CREATE ELECTRONIC CHAIN-OF-CUSTODY (COC) FORMS FOR ENVIRONMENTAL SAMPLES AND SUBMIT THE COCS ELECTRONICALLY TO LABORATORIES, SIGN COCS USING DIGITAL SIGNATURES, FIND AND CONTACT A LABORATORY/LABORATORIES VIA VARIOUS CRITERIA, BROWSE THROUGH ANALYTICAL METHODS, PRINT SAMPLE CONTAINER LABELS, ORDER SAMPLE CONTAINER SUPPLIES FROM LABORATORIES, REQUEST ANALYTICAL SERVICE QUOTES FROM LABORATORIES, IMPORT DATA FROM VARIOUS SOURCES INTO THE SYSTEM, EXPORT DATA STORED IN THE SYSTEM IN VARIOUS ELECTRONIC FORMATS, AND BROWSE THROUGH VENDOR PROMOTIONS (U.S. CLS. 100 AND 101).

FIRST USE 1-11-2011; IN COMMERCE 1-11-2011.
KAREN K. BUSH, EXAMINING ATTORNEY

CLASS 42—(Continued).

SN 85-445,394. CARROLL, THOMAS, LAKEVILLE, MN.
FILED 10-12-2011.



NO CLAIM IS MADE TO THE EXCLUSIVE RIGHT TO USE "PRODUCTIONS", APART FROM THE MARK AS SHOWN.

THE MARK CONSISTS OF THE STYLIZED TEXT "RAIN-CLOUD". ABOVE THE LETTERS "CLOUD" BETWEEN THE LETTERS "L" AND "D" IS THE STYLIZED TEXT "PRODUCTIONS" IN LOWERCASE. OVERLAPPING THE LETTERS "C", "L" AND "O" IN "CLOUD" IS THE TOP OF THE CLOUD GRAPHIC. THE CLOUD GRAPHIC IS TALLEST NEAR THE MIDDLE AND TAPERS OFF ON BOTH SIDES. ON THE BOTTOM-MIDDLE PART OF THE INSIDE OF THE CLOUD GRAPHIC ARE TWO CIRCLES REPRESENTING EYES. IN BETWEEN THE TWO CIRCLES IS A CRESCENT SHAPE INSIDE OF THE CLOUD GRAPHIC REPRESENTING THE CLOUD'S SMILE. BELOW THE CLOUD GRAPHIC ARE THREE SLANTED DROPLET SHAPES REPRESENTING RAIN.

FOR GRAPHIC DESIGN; DESIGN OF COMPUTER GAME SOFTWARE AND VIDEO GAME SOFTWARE; WEB SITE DESIGN (U.S. CLS. 100 AND 101).

FIRST USE 1-1-2010; IN COMMERCE 6-1-2010.

KAREN K. BUSH, EXAMINING ATTORNEY

SN 85-445,410. BAILEY, JORGE R., VANCOUVER, WA.
FILED 10-12-2011.

Gun-Trax

THE MARK CONSISTS OF STANDARD CHARACTERS WITHOUT CLAIM TO ANY PARTICULAR FONT, STYLE, SIZE, OR COLOR.

FOR COMPUTER SERVICES, NAMELY, PROVIDING REGISTERED USERS A WEB-BASED SYSTEM AND ON-LINE PORTAL FEATURING ON-LINE NON-DOWNLOADABLE SOFTWARE THAT ENABLES USERS TO ACCESS WEAPONS CATALOGING AND SUCCESSION TRANSITION MANAGEMENT SYSTEM TO STORE AND MAINTAIN WEAPONS RECORDS, ALLOWS AUTOMATED SERVICE REMINDERS, SAFETY ALERTS, AND RECALL ALERTS, PROVIDES A RESOLUTION PROCESS FOR LOST OR STOLEN WEAPONS, AND ALLOWS GENERAL QUERIES LIMITED BY SPECIFIC WEAPON IDENTIFICATION TO VERIFY THAT THE RECORD EXISTS PROVIDING NON-OWNER SPECIFIC HISTORY (U.S. CLS. 100 AND 101).

SEAN CROWLEY, EXAMINING ATTORNEY

CLASS 42—(Continued).

SN 85-445,455. INTERACTIVE SCHEDULE, INC., CHICAGO, IL. FILED 10-12-2011.



NO CLAIM IS MADE TO THE EXCLUSIVE RIGHT TO USE "INTERACTIVE SCHEDULE.COM", APART FROM THE MARK AS SHOWN.

THE MARK CONSISTS OF A CALENDAR WITH A CIRCULAR ARROW NEXT TO THE WORDS "INTERACTIVE SCHEDULE.COM". THE WORDING "SCHEDULE.COM" APPEARS IN RECTANGLE DESIGN.

FOR COMPUTER SERVICES, NAMELY, HOSTING AN INTERACTIVE WEB SITE THAT ALLOWS USERS TO PUBLISH, SHARE, ORGANIZE, ITEMIZE AND ENTER WORK, VACATION, AND PERSONAL SCHEDULES (U.S. CLS. 100 AND 101).

DANIEL CAPSHAW, EXAMINING ATTORNEY

SN 85-445,476. TRAIL SHERPA LLC, HENDERSON, NV.
FILED 10-12-2011.

TRAIL SHERPA

THE MARK CONSISTS OF STANDARD CHARACTERS WITHOUT CLAIM TO ANY PARTICULAR FONT, STYLE, SIZE, OR COLOR.

FOR CREATION, DESIGN, DEVELOPMENT, HOSTING, AND MAINTENANCE OF WEBSITES FOR OTHERS; CREATING AN ON-LINE COMMUNITY FOR OUTDOOR ENTHUSIASTS TO SHARE AND EXCHANGE INFORMATION, MESSAGES, COMMENTS, IMAGES, VIDEOS AND MULTIMEDIA CONTENT, PARTICIPATE IN DISCUSSIONS, FORM VIRTUAL COMMUNITIES, AND ENGAGE IN SOCIAL NETWORKING; PROVIDING A WEBSITE FEATURING TECHNOLOGY THAT ENABLES USERS TO UPLOAD, POST, SHARE, EXCHANGE, DISPLAY AND VIEW INFORMATION, MESSAGES, COMMENTS, IMAGES AND MULTIMEDIA CONTENT (U.S. CLS. 100 AND 101).

FIRST USE 6-28-2011; IN COMMERCE 6-28-2011.

DAVID C. REIHNER, EXAMINING ATTORNEY

CLASS 42—(Continued).

SN 85-445,512. PARLIAMENT INCORPORATED, PORTLAND, OR. FILED 10-12-2011.

PARLIAMENT

THE MARK CONSISTS OF STANDARD CHARACTERS WITHOUT CLAIM TO ANY PARTICULAR FONT, STYLE, SIZE, OR COLOR.

FOR GRAPHIC DESIGN SERVICES; PLANNING AND LAYOUT DESIGN SERVICES FOR INTERIOR SPACE OF RETAIL BUSINESS ESTABLISHMENTS; WEB SITE DESIGN (U.S. CLS. 100 AND 101).

FIRST USE 9-1-2007; IN COMMERCE 9-1-2007.
TEJBIR SINGH, EXAMINING ATTORNEY

SN 85-445,547. BROWN, MICHAEL L., WAXAHACHIE, TX. FILED 10-12-2011.

SkillsPASS

THE MARK CONSISTS OF STANDARD CHARACTERS WITHOUT CLAIM TO ANY PARTICULAR FONT, STYLE, SIZE, OR COLOR.

FOR SOFTWARE AS A SERVICE (SAAS) SERVICES FEATURING SOFTWARE WHICH TRANSLATES PERSONAL EXPERIENCE, COMPETENCE, KNOWLEDGE ACQUISITION ACTIVITY, DEMONSTRATED PROFICIENCIES AND CAREER OBJECTIVES INTO A COMMON LANGUAGE WHICH IS BENCHMARKED AGAINST REAL-TIME LABOR MARKET INFORMATION, SECONDARY AND POST SECONDARY EDUCATION CONTENT, AND ECONOMIC CLUSTERS (U.S. CLS. 100 AND 101).

FIRST USE 6-0-2011; IN COMMERCE 6-0-2011.
KATHERINE CHANG, EXAMINING ATTORNEY

CLASS 42—(Continued).

SN 85-445,552. A&W CONSULTING GROUP LLC, CHICAGO, IL. FILED 10-12-2011.



NO CLAIM IS MADE TO THE EXCLUSIVE RIGHT TO USE "CONSULTING GROUP LLC", APART FROM THE MARK AS SHOWN.

THE MARK CONSISTS OF A FANCIFUL DESIGN FORMED BY AN "A" AND A "W". TO THE RIGHT IS THE WORDING "A&W CONSULTING", WHICH APPEARS ABOVE THE WORDING "GROUP LLC". THE TWO PHRASES ARE SEPARATED BY A HORIZONTAL LINE.

FOR CONSULTING IN THE FIELD OF INFORMATION TECHNOLOGY; TECHNICAL CONSULTING SERVICES IN THE FIELDS OF DATACENTER ARCHITECTURE, PUBLIC AND PRIVATE CLOUD COMPUTING SOLUTIONS, AND EVALUATION AND IMPLEMENTATION OF INTERNET TECHNOLOGY AND SERVICES (U.S. CLS. 100 AND 101).

FIRST USE 8-16-2005; IN COMMERCE 8-16-2005.
KATHERINE CHANG, EXAMINING ATTORNEY

SN 85-445,664. VISUALZEN, INC., NORFOLK, VA. FILED 10-12-2011.

VZ SUNFLOWER

THE MARK CONSISTS OF STANDARD CHARACTERS WITHOUT CLAIM TO ANY PARTICULAR FONT, STYLE, SIZE, OR COLOR.

THE LETTERS "VZ" HAS NO MEANING OTHER THAN TRADEMARK SIGNIFICANCE.

FOR COMPUTER SERVICES, NAMELY, HOSTING AND MAINTAINING AN ONLINE EDUCATIONAL PORTAL WEBSITE FOR OTHERS THAT ALLOWS USERS TO UPLOAD, EXCHANGE AND SHARE PERSONAL AND EDUCATIONAL INFORMATION (U.S. CLS. 100 AND 101).

STEVEN JACKSON, EXAMINING ATTORNEY

SN 85-445,795. REVOLSUN LLC, HONOLULU, HI. FILED 10-12-2011.



OWNER OF U.S. REG. NO. 3,752,142.
THE MARK CONSISTS OF THE WORD "REVOLUSUN" WITH A FATIGUED CRESCENT SUN DESIGN APPEARING BEFORE THE LETTERS "SUN".

FOR DESIGN OF SOLAR PHOTOVOLTAIC SYSTEMS (U.S. CLS. 100 AND 101).

FIRST USE 9-15-2009; IN COMMERCE 9-15-2009.
BILL DAWE, EXAMINING ATTORNEY

CLASS 42—(Continued).

SN 85-445,821. MITEM CORPORATION, MENLO PARK, CA. FILED 10-12-2011.

BLUE IRIS

THE MARK CONSISTS OF STANDARD CHARACTERS WITHOUT CLAIM TO ANY PARTICULAR FONT, STYLE, SIZE, OR COLOR.

OWNER OF U.S. REG. NOS. 3,055,864, 3,862,064 AND 3,921,032.

FOR PROVIDING TEMPORARY USE OF ONLINE NON-DOWNLOADABLE COMPUTER SOFTWARE IN THE FIELDS OF MEDICAL AND HEALTHCARE RECORDS CREATION AND PROCESSING, NAMELY, PROVIDING RECORD GENERATING CAPACITY, AND PROVIDING INTERCONNECTIVITY AND INTEGRATION OF ELECTRONIC MEDICAL RECORDS, CLINICAL LABORATORY RECORDS, RADIOLOGICAL RECORDS, EPIDEMIOLOGICAL RECORDS, PHARMACOLOGICAL RECORDS, HOSPITALS' RECORDS, PHYSICIANS' RECORDS, PHARMACIES' RECORDS, HEALTHCARE PROVIDERS' RECORDS, INSURANCE PROVIDERS' RECORDS, AND BILLING AND PAYMENT RECORDS OF HEALTHCARE PROVIDERS (U.S. CLS. 100 AND 101).

AMY KELLY, EXAMINING ATTORNEY

CLASS 42—(Continued).

SN 85-445,946. SQUEAKSTER MEDIA LLC, HOPATCONG, NJ. FILED 10-12-2011.



THE MARK CONSISTS OF THE STYLIZED WORD "SQUEAKSTER". AN IMAGE OF A STYLIZED MOUSE TO THE RIGHT OF THE TEXT.

FOR PROVIDING TEMPORARY USE OF NON-DOWNLOADABLE SOFTWARE TO ENABLE UPLOADING, CAPTURING, POSTING, SHOWING, EDITING, PLAYING, STREAMING, VIEWING, PREVIEWING, DISPLAYING, TAGGING, BLOGGING, SHARING, MANIPULATING, DISTRIBUTING, PUBLISHING, REPRODUCING, AND OTHERWISE PROVIDING ELECTRONIC MEDIA, MULTIMEDIA CONTENT, VIDEOS, MOVIES, PICTURES, IMAGES, TEXT, PHOTOS, USER-GENERATED CONTENT, AUDIO CONTENT AND INFORMATION VIA THE INTERNET AND OTHER COMMUNICATIONS NETWORKS; PROVIDING TEMPORARY USE OF NON-DOWNLOADABLE SOFTWARE TO ENABLE SHARING OF MULTIMEDIA CONTENT AND COMMENTS AMONG USERS; PROVIDING TEMPORARY USE OF NON-DOWNLOADABLE SOFTWARE TO ENABLE CONTENT PROVIDERS TO TRACK MULTIMEDIA CONTENT; PROVIDING TEMPORARY USE OF NON-DOWNLOADABLE ANALYTICS SOFTWARE, NAMELY, SOFTWARE THAT PROVIDES STATISTICS ABOUT THE BEHAVIOR OF VIEWERS OF ONLINE VIDEOS, MOVIES, PICTURES, IMAGES, TEXT, PHOTOS, GAMES AND OTHER USER-GENERATED CONTENT; HOSTING OF WEBSITES FEATURING MULTIMEDIA CONTENT FOR OTHERS; HOSTING MULTIMEDIA ENTERTAINMENT AND EDUCATIONAL CONTENT FOR OTHERS; PROVIDING A WEB SITE THAT GIVES COMPUTER USERS THE ABILITY TO UPLOAD AND SHARE USER-GENERATED VIDEOS, ESSAYS AND ARTICLES ON A WIDE VARIETY OF TOPICS AND SUBJECTS (U.S. CLS. 100 AND 101).

GRETTA YAO, EXAMINING ATTORNEY

SN 85-446,158. ALOHAR MOBILE, PALO ALTO, CA. FILED 10-13-2011.

PLACERANK

THE MARK CONSISTS OF STANDARD CHARACTERS WITHOUT CLAIM TO ANY PARTICULAR FONT, STYLE, SIZE, OR COLOR.

FOR PROVIDING ON-LINE NON-DOWNLOADABLE SOFTWARE FOR IDENTIFYING THE USER'S CURRENT AND/OR PREVIOUS LOCATION(S) BY COLLECTING AND ORGANIZING GEOGRAPHICAL DATA (U.S. CLS. 100 AND 101).

EDWARD FENNESSY, EXAMINING ATTORNEY

CLASS 42—(Continued).

SN 85-446,195. UNITED DATA TECHNOLOGIES, INC., DORAL, FL. FILED 10-13-2011.

UDT Corp

THE MARK CONSISTS OF STANDARD CHARACTERS WITHOUT CLAIM TO ANY PARTICULAR FONT, STYLE, SIZE, OR COLOR.

OWNER OF U.S. REG. NOS. 3,183,655, 3,539,726 AND 3,658,918.

FOR INFORMATION TECHNOLOGY CONSULTATION (U.S. CLS. 100 AND 101).

FIRST USE 9-15-2011; IN COMMERCE 9-15-2011.
DAVID HOFFMAN, EXAMINING ATTORNEY

SN 85-446,250. FRILLICI, MARIA A., LOS ANGELES, CA. FILED 10-13-2011.



allura dai design

NO CLAIM IS MADE TO THE EXCLUSIVE RIGHT TO USE "DESIGN", APART FROM THE MARK AS SHOWN.

THE MARK CONSISTS OF A SWIRL WITH FOUR ABSTRACT SYMBOLS ALONG THE LOWER RIGHT SIDE. BELOW THE SWIRL IS THE STYLIZED TEXT "ALLURA DAI DESIGN".

THE WORDING "ALLURA DAI" HAS NO MEANING IN A FOREIGN LANGUAGE.

FOR JEWELRY DESIGN (U.S. CLS. 100 AND 101).
DEBORAH LOBO, EXAMINING ATTORNEY

SN 85-446,348. OPINIONAIDED, INC., RED BANK, NJ. FILED 10-13-2011.

THUMB

THE MARK CONSISTS OF STANDARD CHARACTERS WITHOUT CLAIM TO ANY PARTICULAR FONT, STYLE, SIZE, OR COLOR.

FOR COMPUTER SERVICES, NAMELY, CREATING AN ON-LINE COMMUNITY FOR USERS TO GIVE AND GET OPINIONS AND ADVICE FROM THEIR PEERS AND BUSINESSES (U.S. CLS. 100 AND 101).
PATRICIA EVANKO, EXAMINING ATTORNEY

CLASS 42—(Continued).

SN 85-446,391. IEC ELECTRONICS CORPORATION, NEWARK, NY. FILED 10-13-2011.



THE MARK CONSISTS OF THE LETTERS "DRTL", SHADED, WITH AN AIRPLANE FIGHTER JET LOCATED ABOVE THE "R", AND A CONTRAIL SWOOSHING FROM THE JET DOWN TO THE LEFT AND INTERSECTING WITH THE "D".

FOR DEVELOPMENT AND IMPLEMENTATION OF SOFTWARE, HARDWARE AND TECHNOLOGY SOLUTIONS FOR THE PURPOSE OF TESTING OF ELECTRONIC COMPONENTS AND ELECTRONIC SYSTEMS; DIAGNOSTIC SERVICES IN THE FIELD OF ELECTRONIC AND MICROELECTRONIC DEVICES; MATERIALS TESTING AND ANALYSING; MATERIALS TESTING AND EVALUATION; PRODUCT FAILURE ANALYSIS SERVICES; PRODUCT TESTING; SCIENTIFIC AND TECHNOLOGICAL SERVICES, NAMELY, RISK MITIGATION, TESTING, EVALUATION, AND ANALYSIS IN THE FIELD OF ELECTRONIC AND MICROELECTRONIC DEVICES; TESTING, ANALYSIS, AND EVALUATION OF ELECTRONIC AND MICROELECTRONIC DEVICES TO ASSURE COMPLIANCE WITH INDUSTRY STANDARDS (U.S. CLS. 100 AND 101).

FIRST USE 2-7-2011; IN COMMERCE 6-1-2011.
GIANCARLO CASTRO, EXAMINING ATTORNEY

SN 85-446,453. CULTURE JAM, INC., VENICE, CA. FILED 10-13-2011.

PROMOJAM-GO!

THE MARK CONSISTS OF STANDARD CHARACTERS WITHOUT CLAIM TO ANY PARTICULAR FONT, STYLE, SIZE, OR COLOR.

OWNER OF U.S. REG. NOS. 3,842,982, 3,908,210 AND OTHERS.

FOR PROVIDING A WEBSITE FEATURING NON-DOWNLOADABLE SOFTWARE FOR THIRD PARTY PROMOTERS TO DEVELOP OR DESIGN THE SOFTWARE NECESSARY TO DEVELOP SOCIAL MEDIA VIRAL MARKETING CAMPAIGNS TO ENABLE BUILDING SOCIAL MEDIA VIRAL PROMOTIONAL MARKETING CAMPAIGNS FOR THEIR COMPANY, CLIENT, BRAND OR ARTIST ON THEIR OWN, WITHOUT THE NEED FOR AN INTERMEDIARY TO DEVELOP OR DESIGN THE SOFTWARE NECESSARY TO DEVELOP SOCIAL MEDIA VIRAL MARKETING CAMPAIGNS; COMPUTER SOFTWARE DEVELOPMENT IN THE FIELD OF MOBILE APPLICATIONS (U.S. CLS. 100 AND 101).

FIRST USE 6-0-2011; IN COMMERCE 6-0-2011.
KRISTIN DAHLING, EXAMINING ATTORNEY

CLASS 42—(Continued).

SN 85-446,512. KGROVE, LLC, CHAMPAIGN, IL. FILED 10-13-2011.

KGROVE

THE MARK CONSISTS OF STANDARD CHARACTERS WITHOUT CLAIM TO ANY PARTICULAR FONT, STYLE, SIZE, OR COLOR.

FOR CLOUD COMPUTING FEATURING SOFTWARE FOR USE IN EXPERTISE MANAGEMENT, KNOWLEDGE MANAGEMENT, TALENT MANAGEMENT AND PEOPLE LOCATION (U.S. CLS. 100 AND 101).

FIRST USE 10-21-2009; IN COMMERCE 10-21-2009.
TARAH HARDY, EXAMINING ATTORNEY

SN 85-446,551. SHADOWBOY VENTURES, LLC, MERIDIAN, ID. FILED 10-13-2011.

SHADOW BOY

THE MARK CONSISTS OF STANDARD CHARACTERS WITHOUT CLAIM TO ANY PARTICULAR FONT, STYLE, SIZE, OR COLOR.

FOR APPLICATION SERVICE PROVIDER (ASP), NAMELY, HOSTING COMPUTER SOFTWARE APPLICATIONS OF OTHERS; APPLICATION SERVICE PROVIDER, NAMELY, HOSTING, MANAGING, DEVELOPING, ANALYZING, AND MAINTAINING APPLICATIONS, SOFTWARE, AND WEB SITES, OF OTHERS IN THE FIELDS OF ADVERTISING AND MARKETING; APPLICATION SERVICE PROVIDER, NAMELY, HOSTING, MANAGING, DEVELOPING, ANALYZING, AND MAINTAINING APPLICATIONS, SOFTWARE, AND WEB SITES, OF OTHERS IN THE FIELDS OF HEALTHCARE, BENEFITS PROGRAMS, EMPLOYEE PRODUCTIVITY, RISK MANAGEMENT; APPLICATION SERVICE PROVIDER, NAMELY, HOSTING, MANAGING, DEVELOPING, AND MAINTAINING APPLICATIONS, SOFTWARE, AND WEB SITES, IN THE FIELDS OF PERSONAL PRODUCTIVITY, WIRELESS COMMUNICATION, MOBILE INFORMATION ACCESS, AND REMOTE DATA MANAGEMENT FOR WIRELESS DELIVERY OF CONTENT TO HANDHELD COMPUTERS, LAPTOPS AND MOBILE ELECTRONIC DEVICES; APPLICATION SERVICE PROVIDER, NAMELY, HOSTING, MANAGING, DEVELOPING, ANALYZING, AND MAINTAINING APPLICATIONS, SOFTWARE AND WEB SITES OF OTHERS IN THE FIELDS OF SMALL BUSINESSES; BUILDING AND MAINTAINING WEBSITES; CLOUD COMPUTING FEATURING SOFTWARE FOR USE IN SMALL BUSINESS; COMPUTER CO-LOCATION SERVICES, NAMELY, PROVIDING FACILITIES FOR THE LOCATION OF COMPUTER SERVERS WITH THE EQUIPMENT OF OTHERS; COMPUTER CONSULTATION; COMPUTER CONSULTATION IN THE FIELD OF COMPUTER SECURITY; COMPUTER DISASTER RECOVERY PLANNING; COMPUTER FORENSIC SERVICES; COMPUTER GRAPHICS DESIGN SERVICES; COMPUTER GRAPHICS SERVICES; COMPUTER MONITORING SERVICE WHICH TRACKS APPLICATION SOFTWARE PERFORMANCE, PERFORMS PERIODIC MAINTENANCE AND PROVIDES REPORTS AND ALERTS CONCERNING SUCH PERFORMANCE; COMPUTER MONITORING SERVICE WHICH TRACKS HARDWARE PERFORMANCE AND PROCESSES AND SENDS OUT HISTORICAL REPORTS AND ALERTS; COMPUTER PROGRAMMING AND MAINTENANCE

CLASS 42—(Continued).

OF COMPUTER PROGRAMS; COMPUTER PROGRAMMING AND RENTAL OF COMPUTER PROGRAMS; COMPUTER SECURITY CONSULTANCY; COMPUTER SECURITY CONSULTANCY IN THE FIELD OF SCANNING AND PENETRATION TESTING OF COMPUTERS AND NETWORKS TO ASSESS INFORMATION SECURITY VULNERABILITY; COMPUTER SECURITY SERVICE, NAMELY, RESTRICTING ACCESS TO AND BY COMPUTER NETWORKS TO AND OF UNDESIRE WEB SITES, MEDIA AND INDIVIDUALS AND FACILITIES; COMPUTER SERVICES IN THE NATURE OF CUSTOMIZED WEB PAGES AND OTHER DATA FEED FORMATS FEATURING USER-DEFINED INFORMATION; COMPUTER SERVICES, NAMELY, CLOUD HOSTING PROVIDER SERVICES; COMPUTER SERVICES, NAMELY, CREATING COMPUTER NETWORK-BASED INDEXES OF INFORMATION, WEBSITES AND RESOURCES; COMPUTER SERVICES, NAMELY, CREATING, MAINTAINING, DESIGNING AND IMPLEMENTING WEB SITES FOR OTHERS; COMPUTER SERVICES, NAMELY, DESIGNING AND IMPLEMENTING WEB PAGES FOR OTHERS; COMPUTER SERVICES, NAMELY, DESIGNING AND IMPLEMENTING WEB SITES FOR OTHERS; COMPUTER SERVICES, NAMELY, DIGITAL FORMATTING AND COMPRESSION OF MUSIC AND VIDEO IMAGES INTO DOWNLOADABLE MEDIA; COMPUTER SERVICES, NAMELY, DOMAIN FORWARDING SERVICES; COMPUTER SERVICES, NAMELY, FILTERING OF UNWANTED E-MAILS; COMPUTER SERVICES, NAMELY, HOSTING AN INTERACTIVE WEB SITE THAT ALLOWS AUDIO AND VIDEO FILES; COMPUTER SERVICES, NAMELY, INTERACTIVE HOSTING SERVICES WHICH ALLOW THE USER TO PUBLISH AND SHARE THEIR OWN CONTENT AND IMAGES ON-LINE; COMPUTER SERVICES, NAMELY, INTERNET PROTOCOL ADDRESS MANAGEMENT; COMPUTER SERVICES, NAMELY, MANAGING WEB SITES FOR OTHERS; COMPUTER SERVICES, NAMELY, MONITORING AND REPORTING ON THE PERFORMANCE, AVAILABILITY, AND ERRORS OF WEB SITES OF OTHERS; COMPUTER SERVICES, NAMELY, ON-LINE SCANNING, DETECTING, QUARANTINING AND ELIMINATING OF VIRUSES, WORMS, TROJANS, SPYWARE, MALWARE AND UNAUTHORIZED DATA AND PROGRAMS ON COMPUTERS AND ELECTRONIC DEVICES; COMPUTER SERVICES, NAMELY, PROVIDING AN INTERACTIVE WEB SITE FEATURING TECHNOLOGY THAT ALLOWS USERS TO COLLECT, STORE, MANAGE, DELIVER AND SHOWCASE ELECTRONIC AND PAPER-BASED CONTENT; COMPUTER SERVICES, NAMELY, PROVIDING CUSTOMIZED WEB PAGES FEATURING USER-DEFINED INFORMATION; COMPUTER SERVICES, NAMELY, PROVIDING VIRTUAL AND NON VIRTUAL APPLICATION SERVERS, WEB SERVERS, FILE SERVERS, CO-LOCATION SERVERS, LOAD BALANCING SERVERS, REDUNDANCY SERVERS, MEDIA SERVERS AND DATABASE SERVERS OF VARIABLE CAPACITY TO THIRD PARTY COMPUTING AND DATA STORAGE FACILITIES; COMPUTER SERVICES, NAMELY, REDIRECTING ELECTRONIC MAIL TO CHANGED PERSONAL ELECTRONIC ADDRESS; COMPUTER SERVICES, NAMELY, REMOTE MANAGEMENT OF THE INFORMATION TECHNOLOGY (IT) SYSTEMS OF OTHERS; COMPUTER SERVICES, NAMELY, SEARCH ENGINE OPTIMIZATION; COMPUTER SITE DESIGN; COMPUTER TECHNICAL SUPPORT SERVICES, NAMELY, 24/7 SERVICE DESK/HELP DESK SERVICES FOR IT INFRASTRUCTURE, OPERATING SYSTEMS, DATABASE SYSTEMS, AND WEB APPLICATIONS.; COMPUTER VIRUS PROTECTION SERVICES; COMPUTER WEBSITE DESIGN; CONSULTANCY WITH REGARD TO WEBPAGE DESIGN; CONSULTING IN THE FIELD OF INFORMATION TECHNOLOGY; CONSULTING SERVICES IN THE FIELD OF CLOUD COMPUTING; CONSULTING SERVICES IN THE FIELD OF HOSTING COMPUTER SOFTWARE APPLICATIONS; CONSULTING SERVICES IN THE FIELD OF SEARCH ENGINE OPTIMIZATION; CREATING AND MAINTAINING BLOGS FOR OTHERS; CREATING AND MAINTAINING INTERNET SITES FOR OTHERS; CREATING AND MAINTAINING WEB SITES FOR OTHERS; CREATING AND MAINTAINING WEBLOGS FOR OTHERS; CREATING HOME PAGES FOR OTHERS; CREATING OF HOME PAGES FOR COMPUTER NETWORKS; CREATING WEB PAGES FOR OTHERS; CREATING, DESIGNING AND MAIN-

CLASS 42—(Continued).

TAINING WEB SITES; CREATION AND MAINTENANCE OF WEB SITES FOR OTHERS; CREATION, DESIGN, DEVELOPMENT AND MAINTENANCE OF WEB SITES FOR THIRD PARTIES; DESIGN AND MAINTENANCE OF COMPUTER SITES FOR THIRD PARTIES; DESIGN AND MAINTENANCE OF WEB SITES FOR OTHERS; DESIGN OF HOME PAGES; DESIGN OF HOME PAGES AND WEB SITES; DESIGN OF HOME PAGES, COMPUTER SOFTWARE AND WEB SITES; DESIGN OF HOMEPAGES AND WEBSITES; DESIGN, CREATION, HOSTING AND MAINTENANCE OF INTERNET SITES FOR THIRD PARTIES; DESIGN, CREATION, HOSTING, MAINTENANCE OF WEBSITES FOR OTHERS; DESIGNING AND DEVELOPING WEPPAGES ON THE INTERNET; DESIGNING WEB PAGES FOR OTHERS; DESIGNING WEBSITES FOR ADVERTISING PURPOSES; DESIGNING WEBSITES FOR OTHERS; DEVELOPING AND HOSTING A SERVER ON A GLOBAL COMPUTER NETWORK FOR THE PURPOSE OF FACILITATING E-COMMERCE VIA SUCH A SERVER; DEVELOPING AND IMPLEMENTING CUSTOMIZED PLANS FOR IMPROVING COMPUTER SECURITY AND PREVENTING CRIMINAL ACTIVITY FOR BUSINESSES AND GOVERNMENTAL AGENCIES; DEVELOPMENT, DESIGN AND UPDATING OF HOME PAGES; DISPLAYING THE WEB SITES AND IMAGES OF OTHERS ON A COMPUTER SERVER; DOMAIN NAME SEARCH SERVICES, NAMELY, CONDUCTING ONLINE COMPUTERIZED SEARCHES FOR THE AVAILABILITY OF DOMAIN NAMES ; E-MAIL SYSTEM DESIGN AND IMPLEMENTATION FOR OTHERS; HOMEPAGE AND WEBPAGE DESIGN; HOSTING INTERNET SITES FOR OTHERS; HOSTING OF DIGITAL CONTENT ON THE INTERNET; HOSTING OF WEB SITES; HOSTING THE SOFTWARE, WEBSITES AND OTHER COMPUTER APPLICATIONS OF OTHERS ON A VIRTUAL PRIVATE SERVER; HOSTING THE WEB SITES OF OTHERS ON A COMPUTER SERVER FOR A GLOBAL COMPUTER NETWORK; HOSTING WEBSITES ON THE INTERNET; INFORMATION TECHNOLOGY CONSULTATION; MAINTENANCE OF WEBSITES AND HOSTING ON-LINE WEB FACILITIES FOR OTHERS; MANAGING WEB SITES FOR OTHERS; ON-LINE SECURITY SERVICES, NAMELY, PROVIDING SECURITY AND ANONYMITY FOR ELECTRONICALLY TRANSMITTED CREDIT CARD TRANSACTIONS; ONLINE COMPUTER SERVICES, NAMELY, PROVIDING SPAM FILTERING SERVICES TO PROTECT WEBSITES AND ONLINE APPLICATIONS FROM RECEIVING UNSOLICITED MESSAGES; PLANNING, DESIGN, DEVELOPMENT, MAINTENANCE AND OPTIMIZATION OF ONLINE WEBSITES FOR THIRD PARTIES; PROVIDING A MEMBERS-ONLY WEBSITE FEATURING TECHNOLOGY WHICH PROVIDES MEMBERS WITH THE ABILITY TO ENCRYPT PAYMENT INFORMATION FOR PAYING INVOICES OVER THE INTERNET; PROVIDING A SECURE ELECTRONIC ONLINE SYSTEM FEATURING TECHNOLOGY WHICH ALLOWS VENDORS TO SUBMIT ELECTRONIC INVOICES TO SALES REPRESENTATIVE AGENCIES FOR IMPORTING AND PROCESSING OF ELECTRONIC INVOICES TO SAVE TIME AND IMPROVE ACCURACY; PROVIDING A SECURE, WEB-BASED SERVICE ENABLING INDIVIDUALS TO REMOTELY CREATE AND MANAGE THEIR OWN ACCOUNTS SO THAT WHATEVER PRIVATE CONTENT THEY UPLOAD NOW CAN BE ENCRYPTED, THEN DELIVERED TO THEIR INTENDED RECIPIENTS, AT THE TIME AND IN THE MANNER REQUESTED; PROVIDING A SECURED-ACCESS WEBSITE THAT GIVES REGISTERED INTERNET NETWORKED INSTITUTIONS THE ABILITY TO UPLOAD, VIEW, COPY, PRINT, DOWNLOAD AND SHARE DOCUMENTS AND IMAGES FOR THE PURPOSES OF CONDUCTING CONSUMER-DRIVEN TRANSACTIONS; PROVIDING A WEB SITE ALLOWING USERS TO UPLOAD ON-LINE VIDEOS FOR SHARING WITH OTHERS FOR MOTIVATIONAL AND INSPIRATIONAL PURPOSES; PROVIDING A WEB SITE THAT GIVES COMPUTER USERS THE ABILITY TO UPLOAD AND SHARE USER-GENERATED VIDEOS, ESSAYS AND ARTICLES ON A WIDE VARIETY OF TOPICS AND SUBJECTS (U.S. CLS. 100 AND 101).

FIRST USE 2-5-2004; IN COMMERCE 2-5-2004.
JAY FLOWERS, EXAMINING ATTORNEY

CLASS 42—(Continued).

SN 85-446,587. GREEN CIRCLE, LLC, ALPHARETTA, GA.
FILED 10-13-2011.

YOUMITTER

THE MARK CONSISTS OF STANDARD CHARACTERS WITHOUT CLAIM TO ANY PARTICULAR FONT, STYLE, SIZE, OR COLOR.

FOR COMPUTER SERVICES, NAMELY, CREATING AN ON-LINE COMMUNITY FOR REGISTERED USERS TO PARTICIPATE IN DISCUSSIONS, GET FEEDBACK FROM THEIR PEERS, FORM VIRTUAL COMMUNITIES, AND ENGAGE IN SOCIAL NETWORKING SERVICES IN THE FIELD OF RELATIONSHIPS, DATING, POLITICS, RELIGION, SPIRITUAL, FAMILIAL, SOCIAL, TOPICAL INTERESTS; COMPUTER SERVICES, NAMELY, CREATING AN ON-LINE COMMUNITY FOR REGISTERED USERS TO ENGAGE IN ANONYMOUS SOCIAL INTERACTION THROUGH MESSAGING, MICRO-BLOGGING, CHATTING, EMAIL, TEXTING (U.S. CLS. 100 AND 101).

KATHY DE JONGE, EXAMINING ATTORNEY

SN 85-446,681. HAMAGAMI/CARROLL, INC., LOS ANGELES, CA. FILED 10-13-2011.

OPEN BAR

THE MARK CONSISTS OF STANDARD CHARACTERS WITHOUT CLAIM TO ANY PARTICULAR FONT, STYLE, SIZE, OR COLOR.

FOR COMPUTER SERVICES, NAMELY, CREATING, MAINTAINING, DESIGNING, AND IMPLEMENTING WEBSITES FOR OTHERS IN THE FIELD OF MULTIMEDIA DESIGN AND USER INTERFACE DESIGN FOR MOBILE APPLICATIONS, MOBILE PLATFORMS AND MOBILE DEVICES; COMPUTER SERVICES, NAMELY, DESIGNING AND IMPLEMENTING INTERACTIVE WEBSITES, MOBILE APPLICATIONS AND MOBILE PLATFORMS FOR OTHERS; COMPUTER SOFTWARE DEVELOPMENT IN THE FIELD OF MOBILE APPLICATIONS; COMPUTER WEBSITE DESIGN; GRAPHIC DESIGN; WEBSITE DESIGN AND DEVELOPMENT FOR OTHERS (U.S. CLS. 100 AND 101).

ADA HAN, EXAMINING ATTORNEY

CLASS 42—(Continued).

SN 85-446,771. VEDDIO, LLC, FT. LAUDERDALE, FL.
FILED 10-13-2011.



THE MARK CONSISTS OF THE WORD "VEDDIO" WITH A COLON AT THE END OF IT AND NINE CIRCLES SITUATED ABOVE.

FOR DESIGN, CREATION, HOSTING, MAINTENANCE OF WEBSITES FOR OTHERS; HOSTING INTERNET SITES FOR OTHERS; HOSTING OF DIGITAL CONTENT ON THE INTERNET; HOSTING WEBSITES ON THE INTERNET; PROVIDING A WEB SITE FEATURING TECHNOLOGY THAT ENABLES USERS TO PRESENT PRODUCTS, SERVICES, AND PROPOSALS TO OTHERS FOR COMMENT, AND GATHER FEEDBACK FROM THOSE OTHERS ABOUT THOSE PRODUCTS, SERVICES, AND PROPOSALS; PROVIDING VIRTUAL COMPUTER SYSTEMS AND VIRTUAL COMPUTER ENVIRONMENTS THROUGH CLOUD COMPUTING (U.S. CLS. 100 AND 101).

FIRST USE 11-9-2006; IN COMMERCE 3-1-2009.
SALLY SHIH, EXAMINING ATTORNEY

SN 85-447,003. CLEAR CONSULTING, LLC, MINNEAPOLIS, MN. FILED 10-13-2011.

SOFTWARE FOR GOOD

THE MARK CONSISTS OF STANDARD CHARACTERS WITHOUT CLAIM TO ANY PARTICULAR FONT, STYLE, SIZE, OR COLOR.

NO CLAIM IS MADE TO THE EXCLUSIVE RIGHT TO USE "SOFTWARE", APART FROM THE MARK AS SHOWN. FOR COMPUTER SOFTWARE DEVELOPMENT (U.S. CLS. 100 AND 101).

FIRST USE 4-23-2010; IN COMMERCE 4-23-2010.
JERI J. FICKES, EXAMINING ATTORNEY

CLASS 42—(Continued).

SN 85-447,434. COMPLEX MEDIA, INC., NEW YORK, NY.
FILED 10-14-2011.

NTRSCTN

THE MARK CONSISTS OF STANDARD CHARACTERS WITHOUT CLAIM TO ANY PARTICULAR FONT, STYLE, SIZE, OR COLOR.

FOR PROVIDING A WEBSITE FEATURING TECHNOLOGY THAT ENABLES USERS TO UPLOAD, POST, SHOW, VIEW, DISPLAY, CATEGORIZE, SEARCH, DOWNLOAD, RATE, COMMENT UPON, STORE, TAG, BLOG, AND SHARE NEWS STORIES AND ARTICLES IN THE FIELDS OF PERSONAL STYLE, SHOPPING, MUSIC, ART, GAMING, CLOTHING, ENTERTAINMENT AND SPORTS, AND THEN RANKING AND SORTING THE NEWS STORIES AND ARTICLES BASED UPON POPULARITY AND RELEVANCE; COMPUTER SERVICES, NAMELY, CREATING AN ON-LINE COMMUNITY FOR REGISTERED USERS TO PARTICIPATE IN DISCUSSIONS, GET FEEDBACK FROM THEIR PEERS, FORM VIRTUAL COMMUNITIES, AND ENGAGE IN SOCIAL NETWORKING; COMPUTER SERVICES, NAMELY, HOSTING ON-LINE WEB FACILITIES FOR OTHERS FOR ORGANIZING AND CONDUCTING ON-LINE MEETINGS, GATHERINGS, AND INTERACTIVE DISCUSSIONS; APPLICATION SERVICE PROVIDER (ASP) FEATURING SOFTWARE TO ENABLE OR FACILITATE THE UPLOADING, DOWNLOADING, STREAMING, POSTING, DISPLAYING, BLOGGING, LINKING, SHARING OR OTHERWISE PROVIDING ELECTRONIC MEDIA OR INFORMATION OVER COMMUNICATION NETWORKS; PROVIDING AN ONLINE NETWORK SERVICE THAT ENABLES USERS TO TRANSFER PERSONAL IDENTITY DATA TO AND SHARE PERSONAL IDENTITY DATA WITH AND AMONG MULTIPLE WEBSITES; PROVIDING A WEB SITE FEATURING TECHNOLOGY THAT ENABLES ONLINE USERS TO CREATE PERSONAL PROFILES FEATURING SOCIAL NETWORKING INFORMATION AND TO TRANSFER AND SHARE SUCH INFORMATION AMONG MULTIPLE WEBSITES; PROVIDING TEMPORARY USE OF ONLINE NON-DOWNLOADABLE SOFTWARE, NAMELY, SOFTWARE TO TRACK WEB SITE USER ACTIVITY, DELIVER TARGETED DATA AND INFORMATION TO WEB SITE USERS BASED ON AMBIENT, BEHAVIORAL, OR EXPLICITLY PROVIDED DATA, MEASURE AND TEST USER AFFINITY FOR MATERIAL AND CONTENT ALTERNATIVES, AND CAPTURE AND REPORT ON DATA SUBMITTED BY WEB SITE USERS VIA THE APPLICATION (U.S. CLS. 100 AND 101).

WILLIAM JACKSON, EXAMINING ATTORNEY

CLASS 42—(Continued).

SN 85-447,495. VISUAL ADVERTISING SALES TECHNOLOGY, GRASS VALLEY, CA. FILED 10-14-2011.



OWNER OF U.S. REG. NO. 3,650,196.
THE MARK CONSISTS OF A TAPERING BOX SHAPE WITH AN INVERTED-V ANTENNA EXTENDING UPWARDLY FROM THE TAPERING BOX WITH THE WORD SHOWSEEKER IN STYLIZED LETTERING EXTENDING FROM AN OPEN RIGHT SIDE OF THE TAPERING BOX.
FOR PROVIDING ONLINE NON-DOWNLOADABLE SOFTWARE FOR USE IN TELEVISED MEDIA SCHEDULING THAT ALLOWS USERS TO ACCESS UPCOMING TELEVISED MEDIA SCHEDULES TO DETERMINE WHERE AND WHEN THEY WOULD LIKE THEIR ADVERTISEMENTS TO APPEAR, AND HELPS MEDIA OUTLETS CREATE AND SEND PROPOSALS TO THOSE USERS TO EXPEDITE THE ADVERTISING SALES PROCESS (U.S. CLS. 100 AND 101).
KATHERINE STOIDES, EXAMINING ATTORNEY

SN 85-447,750. KAHUA, INC., ALPHARETTA, GA. FILED 10-14-2011.

KCREATOR

THE MARK CONSISTS OF STANDARD CHARACTERS WITHOUT CLAIM TO ANY PARTICULAR FONT, STYLE, SIZE, OR COLOR.
FOR SOFTWARE AS A SERVICE (SAAS) SERVICES, NAMELY, HOSTING AND MANAGING ONLINE SOFTWARE FOR OTHERS THAT ENABLES USE, DEVELOPMENT, AND SHARING OF SOFTWARE APPLICATIONS; PROVIDING TEMPORARY USE OF ON-LINE, NON-DOWNLOADABLE COMPUTER SOFTWARE THAT ENABLES USERS TO CREATE AND DEVELOP COMPUTER SOFTWARE PROGRAMS (U.S. CLS. 100 AND 101).
DANNEAN HETZEL, EXAMINING ATTORNEY

CLASS 42—(Continued).

SN 85-447,995. ELECTRONIC IMAGING SERVICES, INC., DBA VESTCOM RETAIL SOLUTIONS, LITTLE ROCK, AR. FILED 10-14-2011.

AisleWise

THE MARK CONSISTS OF STANDARD CHARACTERS WITHOUT CLAIM TO ANY PARTICULAR FONT, STYLE, SIZE, OR COLOR.
FOR CREATION AND DESIGN OF PLANOGRAMS AND PRICING LABELS FOR RETAILERS (U.S. CLS. 100 AND 101).
RONALD MCMORROW, EXAMINING ATTORNEY

SN 85-448,180. SILVAS, JAMES, M., HENDERSON, NV. FILED 10-14-2011.



THE MARK CONSISTS OF THE LETTER "G" WITH A MODIFIED PR/QT INTERVAL MARKING MERGED INTO THE "G"; THE LETTER "G" REPRESENTS "GYM" AND THE PR/QT INTERVAL MARKING REPRESENTS "WIRE".
FOR PROVIDING A WEB SITE FEATURING TECHNOLOGY THAT ENABLES INTERNET USERS TO CREATE, BOOKMARK, ANNOTATE, AND PUBLICLY SHARE DATA (U.S. CLS. 100 AND 101).
GRETTA YAO, EXAMINING ATTORNEY

CLASS 42—(Continued).

SN 85-448,464. TITZER, PATRICK THOMAS, CENTENNIAL, CO. AND ENTREPRENUITY, CENTENNIAL, CO. FILED 10-16-2011.

EntrepreNuity

THE MARK CONSISTS OF STANDARD CHARACTERS WITHOUT CLAIM TO ANY PARTICULAR FONT, STYLE, SIZE, OR COLOR.

FOR COMPUTER SERVICES, NAMELY, CREATING, MAINTAINING, DESIGNING AND IMPLEMENTING WEB SITES FOR OTHERS; COMPUTER SERVICES, NAMELY, DESIGNING AND IMPLEMENTING WEB PAGES FOR OTHERS; COMPUTER SERVICES, NAMELY, DESIGNING AND IMPLEMENTING WEB SITES FOR OTHERS; CREATING AND DESIGNING WEB PAGES FOR OTHERS; CREATING AND DESIGNING WEB PAGES FOR OTHERS; CREATING AND MAINTAINING WEB SITES FOR OTHERS; CREATING WEB PAGES FOR OTHERS; CREATING, DESIGNING AND MAINTAINING WEB SITES; CREATION AND MAINTENANCE OF WEB SITES FOR OTHERS; DESIGN AND CREATING WEB SITES FOR OTHERS; DESIGN AND MAINTENANCE OF WEB SITES FOR OTHERS; DESIGN OF HOME PAGES AND WEB SITES; DESIGN OF HOME PAGES, COMPUTER SOFTWARE AND WEB SITES; DESIGNING WEB PAGES FOR OTHERS; WEB SITE DESIGN; WEB SITE DEVELOPMENT FOR OTHERS (U.S. CLS. 100 AND 101).

COURTNEY ALVAREZ, EXAMINING ATTORNEY

SN 85-448,517. PETZOOMBA, LLC, BROOKFIELD, CT. FILED 10-17-2011.

Petzoomba

THE MARK CONSISTS OF STANDARD CHARACTERS WITHOUT CLAIM TO ANY PARTICULAR FONT, STYLE, SIZE, OR COLOR.

FOR COMPUTER SERVICES, NAMELY, CREATING AN ON-LINE COMMUNITY FOR REGISTERED USERS, NAMELY, PET OWNERS, VETERINARIANS, PET INDUSTRY RETAILERS, MANUFACTURERS, ENTREPRENEURS AND PET SERVICE PROVIDERS TO PARTICIPATE IN DISCUSSIONS, GET FEEDBACK FROM THEIR PEERS, FORM VIRTUAL COMMUNITIES, AND ENGAGE IN SOCIAL NETWORKING SERVICES IN THE FIELD OF PROMOTING AND ADVANCING PET CARE AND PET WELLNESS (U.S. CLS. 100 AND 101).

ANTHONY RINKER, EXAMINING ATTORNEY

CLASS 42—(Continued).

SN 85-448,552. BOATHOUSE GROUP, INC., WALTHAM, MA. FILED 10-17-2011.

SPEEDBILLY

THE MARK CONSISTS OF STANDARD CHARACTERS WITHOUT CLAIM TO ANY PARTICULAR FONT, STYLE, SIZE, OR COLOR.

FOR SOFTWARE-AS-A-SERVICE (SAAS) SERVICES FEATURING E-COMMERCE SOFTWARE THAT ALLOWS USERS TO PERFORM ELECTRONIC BUSINESS TRANSACTIONS VIA THE INTERNET, AND THAT ALLOWS THE VENDORS OF MOTOR VEHICLES TO ADVERTISE THEIR INVENTORIES ONLINE (U.S. CLS. 100 AND 101).

HOWARD SMIGA, EXAMINING ATTORNEY

SN 85-449,311. CAKEMAIL INC., MONTREAL, CANADA, FILED 10-17-2011.

CAKEMAIL

THE MARK CONSISTS OF STANDARD CHARACTERS WITHOUT CLAIM TO ANY PARTICULAR FONT, STYLE, SIZE, OR COLOR.

FOR PROVIDING ON-LINE NON-DOWNLOADABLE SOFTWARE FOR SUPPORTING AND MANAGING THE CREATION AND SENDING OF BULK ELECTRONIC MAIL (U.S. CLS. 100 AND 101).

FIRST USE 1-10-2007; IN COMMERCE 1-10-2007.

JACQUELINE A. LAVINE, EXAMINING ATTORNEY

SN 85-449,313. 3KEYLOGIC, LLC, BLOOMINGTON, MN. FILED 10-17-2011.



THE MARK CONSISTS OF THE STYLIZED NUMBER AND WORDS "3KEYLOGIC". AN IMAGE OF THREE C-SHAPED DESIGNS TO THE LEFT OF THE TEXT.

FOR IT CONSULTING SERVICES (U.S. CLS. 100 AND 101).

FIRST USE 1-1-2004; IN COMMERCE 1-1-2004.

SUNG IN, EXAMINING ATTORNEY

CLASS 42—(Continued).

SN 85-449,326. CAKEMAIL INC., MONTREAL, CANADA, FILED 10-17-2011.



THE MARK CONSISTS OF AN IMAGE OF CAKE WITH THE WORD CAKE IS WRITTEN INSIDE IT AS SHOWN IN THE MARK.

FOR PROVIDING ON-LINE NON-DOWNLOADABLE SOFTWARE FOR SUPPORTING AND MANAGING THE CREATION AND SENDING OF BULK ELECTRONIC MAIL (U.S. CLS. 100 AND 101).

FIRST USE 1-10-2007; IN COMMERCE 1-10-2007.
JACQUELINE A. LAVINE, EXAMINING ATTORNEY

SN 85-449,357. ROOF CHICKEN, LLC, GLENDALE, AZ. FILED 10-17-2011.

Roof Chicken

THE MARK CONSISTS OF STANDARD CHARACTERS WITHOUT CLAIM TO ANY PARTICULAR FONT, STYLE, SIZE, OR COLOR.

FOR COMPUTER SERVICES, NAMELY, PROVIDING SEARCH ENGINES FOR OBTAINING DATA ON A GLOBAL COMPUTER NETWORK; PROVIDING A WEB-SITE FEATURING A MEDIA AGGREGATOR AND SEARCH ENGINE FOR INTERNET CONTENT (U.S. CLS. 100 AND 101).

MATTHEW PAPPAS, EXAMINING ATTORNEY

CLASS 42—(Continued).

SN 85-449,398. OCTOPI LLC, DBA DEEP SEA DESIGN, SAINT GEORGE, UT. FILED 10-18-2011.



THE MARK CONSISTS OF A STYLIZED DESIGN OF AN OCTOPUS.

FOR MULTIDISCIPLINARY GRAPHIC DESIGN SERVICES (U.S. CLS. 100 AND 101).

FIRST USE 11-1-2008; IN COMMERCE 5-1-2010.
SHAILA SETTLES, EXAMINING ATTORNEY

SN 85-449,469. DINUBILE, NICHOLAS A, HAVERTOWN, PA. FILED 10-18-2011.

FrameCheck

THE MARK CONSISTS OF STANDARD CHARACTERS WITHOUT CLAIM TO ANY PARTICULAR FONT, STYLE, SIZE, OR COLOR.

FOR PROVIDING ON-LINE NON-DOWNLOADABLE SOFTWARE FOR USE BY FITNESS PROFESSIONALS, HEALTH CLUBS AND MEDICAL PROFESSIONALS FOR MAKING ASSESSMENTS OF INDIVIDUALS' HEALTH, WELLNESS, FITNESS AND LIFESTYLE AND CREATION OF CUSTOMIZED COMPUTERIZED REPORTS RELATING THERETO (U.S. CLS. 100 AND 101).

JENNIFER DIXON, EXAMINING ATTORNEY

SN 85-449,471. HANCOCK, DANIEL, JOHNSON & NAGLE, P.C., GLEN ALLEN, VA. FILED 10-18-2011.

ROCKENROLL

THE MARK CONSISTS OF STANDARD CHARACTERS WITHOUT CLAIM TO ANY PARTICULAR FONT, STYLE, SIZE, OR COLOR.

FOR COMPUTER SERVICES, NAMELY, PROVIDING AN INTERACTIVE WEB SITE FEATURING TECHNOLOGY THAT ALLOWS USERS TO PROVIDE INFORMATION FOR AND MONITOR THE STATUS OF MEDICARE ENROLLMENT APPLICATIONS (U.S. CLS. 100 AND 101).

FIRST USE 9-30-2011; IN COMMERCE 9-30-2011.
KATHERINE STOIDES, EXAMINING ATTORNEY

CLASS 42—(Continued).

SN 85-449,544. TENSION INTERNATIONAL, INC., KANSAS CITY, MO. FILED 10-18-2011.



NO CLAIM IS MADE TO THE EXCLUSIVE RIGHT TO USE "PACKAGING & AUTOMATION", APART FROM THE MARK AS SHOWN.

THE MARK CONSISTS OF THE WORD TENSION ABOVE THE WORDS PACKAGING & AUTOMATION; STYLIZED LETTER T INSIDE A CIRCLE TO THE UPPER RIGHT OF THE WORD TENSION; AND THE WORDS INGENUITY AT WORK TO THE RIGHT OF THE CIRCLE.

FOR DESIGN, DEVELOPMENT, ENGINEERING, AND TESTING OF AUTOMATED EQUIPMENT, NAMELY, PACKAGING SYSTEMS, MAIL-ORDER SYSTEMS, CENTRAL-FILL SYSTEMS, PRE-PACK SYSTEMS, DIRECT-TO-CONSUMERS SYSTEMS, AND PHARMACY SYSTEMS (U.S. CLS. 100 AND 101).

FIRST USE 7-13-2011; IN COMMERCE 7-13-2011.

ADA HAN, EXAMINING ATTORNEY

CLASS 42—(Continued).

SN 85-449,749. AVIIR, INC., IRVINE, CA. FILED 10-18-2011.

TRURISK

THE MARK CONSISTS OF STANDARD CHARACTERS WITHOUT CLAIM TO ANY PARTICULAR FONT, STYLE, SIZE, OR COLOR.

FOR MEDICAL LABORATORY SERVICES (U.S. CLS. 100 AND 101).

DOMINIC J. FERRAIUOLO, EXAMINING ATTORNEY

SN 85-449,952. CINDY PERRY, VERNAL, UT. FILED 10-18-2011.

MEMORY MARK

SN 85-449,721. SCANBUGGY LLC, TEQUESTA, FL. FILED 10-18-2011.



NO CLAIM IS MADE TO THE EXCLUSIVE RIGHT TO USE THE DESIGN OF THE QUICK RESPONSE CODE, APART FROM THE MARK AS SHOWN.

THE COLOR(S) BLACK, WHITE AND RED IS/ARE CLAIMED AS A FEATURE OF THE MARK.

THE MARK CONSISTS OF A BLACK AND WHITE QUICK RESPONSE DESIGN CODE WITH A RED AND BLACK LADYBUG IMAGE IN THE CENTER OF THE CODE. TO THE RIGHT OF THE QUICK RESPONSE DESIGN CODE IS THE WORD "SCAN" IN RED WITH BLOCK STYLE UPPERCASE LETTERING. BELOW THE WORD "SCAN" IS THE WORD "BUGGY.COM". THE WORD "BUGGY" IS IN BLACK IN BLOCK STYLE UPPERCASE LETTERING. DIRECTLY TO THE RIGHT OF "BUGGY" IS THE WORD ".COM" IN BLACK, LOWERCASE ITALIC LETTERING.

FOR PROVIDING TEMPORARY USE OF ONLINE NON-DOWNLOADABLE SOFTWARE WHICH ALLOWS USERS TO CREATE AND GENERATE QUICK RESPONSE BAR CODE MARKETING APPLICATIONS AND TO GENERATE QUICK RESPONSE BAR CODES TO BE USED IN PRODUCTION OF USER CREATED BUSINESS CARDS AND SOCIAL CARDS (U.S. CLS. 100 AND 101).

COLLEEN KEARNEY, EXAMINING ATTORNEY

THE MARK CONSISTS OF STANDARD CHARACTERS WITHOUT CLAIM TO ANY PARTICULAR FONT, STYLE, SIZE, OR COLOR.

FOR PROVIDING A SECURED-ACCESS WEBSITE THAT GIVES MEMBERS THE ABILITY TO ORGANIZE, STORE AND RETRIEVE PERSONAL INFORMATION (U.S. CLS. 100 AND 101).

JILL PRATER, EXAMINING ATTORNEY

SN 85-449,961. CINDY PERRY, VERNAL, UT. FILED 10-18-2011.



THE MARK CONSISTS OF THE WORDS "MEMORY" AND "MARK" SEPARATED BY AN IMAGE OF A PERSON WITH HANDPRINTS ABOVE THE PERSON'S OUT-STRETCHED HANDS.

FOR PROVIDING A SECURED-ACCESS WEBSITE THAT GIVES MEMBERS THE ABILITY TO ORGANIZE, STORE AND RETRIEVE PERSONAL INFORMATION (U.S. CLS. 100 AND 101).

JILL PRATER, EXAMINING ATTORNEY

CLASS 42—(Continued).

SN 85-450,056. CLARKSON UNIVERSITY, POTSDAM, NY. FILED 10-18-2011.

NEED IT -GET IT

THE MARK CONSISTS OF STANDARD CHARACTERS WITHOUT CLAIM TO ANY PARTICULAR FONT, STYLE, SIZE, OR COLOR.
FOR INFORMATION TECHNOLOGY CONSULTATION (U.S. CLS. 100 AND 101).
MICHAEL GAAFAR, EXAMINING ATTORNEY

SN 85-450,221. CELSIS INTERNATIONAL LIMITED, CHICAGO, IL. FILED 10-18-2011.

SMART SCIENCE FOR SMART BUSINESS

THE MARK CONSISTS OF STANDARD CHARACTERS WITHOUT CLAIM TO ANY PARTICULAR FONT, STYLE, SIZE, OR COLOR.
FOR PROVIDING SCIENTIFIC LABORATORY RESEARCH AND TESTING SERVICES IN THE FIELDS OF CHEMISTRY, BIOLOGY, AND STABILITY TESTING (U.S. CLS. 100 AND 101).
FIRST USE 4-20-2010; IN COMMERCE 4-20-2010.
DOUGLAS LEE, EXAMINING ATTORNEY

SN 85-450,306. SOGWAP SOLUTIONS, LITTLETON, CO. FILED 10-18-2011.

Sogwap

THE MARK CONSISTS OF STANDARD CHARACTERS WITHOUT CLAIM TO ANY PARTICULAR FONT, STYLE, SIZE, OR COLOR.
FOR COMPUTER SOFTWARE TECHNOLOGY CONSULTING (U.S. CLS. 100 AND 101).
FIRST USE 5-10-2000; IN COMMERCE 6-1-2003.
NANCY CLARKE, EXAMINING ATTORNEY

CLASS 42—(Continued).

SN 85-450,361. POWER FREIGHT SYSTEMS, INC., NEWARK, CA. FILED 10-18-2011.

JAVELIN LOGISTICS

THE MARK CONSISTS OF STANDARD CHARACTERS WITHOUT CLAIM TO ANY PARTICULAR FONT, STYLE, SIZE, OR COLOR.
NO CLAIM IS MADE TO THE EXCLUSIVE RIGHT TO USE "LOGISTICS", APART FROM THE MARK AS SHOWN.
FOR PROVIDING A WEB SITE FEATURING NON-DOWNLOADABLE SOFTWARE THAT ENABLES SHIPPERS OF FREIGHT USING TRUCK, RAIL, OCEAN OR AIR TRANSPORTATION TO SELECT ROUTES AND CARRIERS, TO COMMUNICATE WITH CARRIERS, AND TO MANAGE PICKUP AND DELIVERY OF SHIPMENTS (U.S. CLS. 100 AND 101).
LAURIE MAYES, EXAMINING ATTORNEY

SN 85-451,515. PINE LAKE MARKETING, L.L.C., PETOSKEY, MI. FILED 10-19-2011.

SUNGEM

THE MARK CONSISTS OF STANDARD CHARACTERS WITHOUT CLAIM TO ANY PARTICULAR FONT, STYLE, SIZE, OR COLOR.
FOR COMPUTER SERVICES, NAMELY, CREATING, MAINTAINING, DESIGNING AND IMPLEMENTING WEB SITES FOR OTHERS; COMPUTER SERVICES, NAMELY, DESIGNING AND IMPLEMENTING WEB PAGES FOR OTHERS; COMPUTER SERVICES, NAMELY, DESIGNING AND IMPLEMENTING WEB SITES FOR OTHERS; COMPUTER SITE DESIGN; COMPUTER WEBSITE DESIGN; CONSULTANCY WITH REGARD TO WEBPAGE DESIGN; CREATING AND DESIGNING WEB PAGES FOR OTHERS; CREATING, DESIGNING AND MAINTAINING WEB SITES; CREATION, DESIGN, DEVELOPMENT AND MAINTENANCE OF WEB SITES FOR THIRD PARTIES; DESIGN AND CREATING WEB SITES FOR OTHERS; DESIGN AND MAINTENANCE OF WEB SITES FOR OTHERS; DESIGN OF HOMEPAGES AND WEBSITES; DESIGN, CREATION, HOSTING, MAINTENANCE OF WEBSITES FOR OTHERS; PROVIDING A WEBSITE THAT GIVES USERS THE ABILITY TO CREATE CUSTOMIZED WEB PAGES FEATURING USER-DEFINED INFORMATION; PROVIDING A WEBSITE THAT GIVES USERS THE ABILITY TO CREATE CUSTOMIZED WEB PAGES FEATURING USER-DEFINED PROFILES (U.S. CLS. 100 AND 101).
FIRST USE 6-1-2010; IN COMMERCE 6-1-2010.
JACQUELINE A. LAVINE, EXAMINING ATTORNEY

CLASS 42—(Continued).

SN 85-451,737. APEX INDUSTRIAL TECHNOLOGIES LLC, MASON, OH. FILED 10-20-2011.



THE MARK CONSISTS OF THE WORDS "SMARTER SPACES" WITH THE WORD "SMARTER" ABOVE THE WORD "SPACES" WITH A STYLIZED LINES TO THE LEFT OF THE WORDS WHICH MAKE UP A CIRCULAR DESIGN.

FOR COMPUTER SERVICES, NAMELY, PROVIDING A WEB-BASED SYSTEM AND ONLINE PORTAL FEATURING ON-LINE NON-DOWNLOADABLE SOFTWARE FOR USE IN TRACKING, PROCESSING AND PROVIDING USER ACCESS TO DATA RELATING TO DISPENSING, ACCESS AND USAGE OF HARDWARE, PARTS, SUPPLIES, COMPONENTS AND THE LIKE, AND FOR USE IN SUPPLY CHAIN MANAGEMENT, INVENTORY CONTROL, ACCESS CONTROL, DEMAND MANAGEMENT AND PROCESS CONTROL (U.S. CLS. 100 AND 101).

VIVIAN MICZNIK FIRST, EXAMINING ATTORNEY

SN 85-451,741. APEX INDUSTRIAL TECHNOLOGIES LLC, MASON, OH. FILED 10-20-2011.

MAKING SPACES SMART

THE MARK CONSISTS OF STANDARD CHARACTERS WITHOUT CLAIM TO ANY PARTICULAR FONT, STYLE, SIZE, OR COLOR.

FOR COMPUTER SERVICES, NAMELY, PROVIDING A WEB-BASED SYSTEM AND ONLINE PORTAL FEATURING ON-LINE NON-DOWNLOADABLE SOFTWARE FOR USE IN TRACKING, PROCESSING AND PROVIDING USER ACCESS TO DATA RELATING TO DISPENSING, ACCESS AND USAGE OF HARDWARE, PARTS, SUPPLIES, COMPONENTS AND THE LIKE, AND FOR USE IN SUPPLY CHAIN MANAGEMENT, INVENTORY CONTROL, ACCESS CONTROL, DEMAND MANAGEMENT AND PROCESS CONTROL (U.S. CLS. 100 AND 101).

VIVIAN MICZNIK FIRST, EXAMINING ATTORNEY

CLASS 42—(Continued).

SN 85-453,162. SYNEDGEN, INC, CLAREMONT, CA. FILED 10-21-2011.

SYNEDGEN

THE MARK CONSISTS OF STANDARD CHARACTERS WITHOUT CLAIM TO ANY PARTICULAR FONT, STYLE, SIZE, OR COLOR.

FOR RESEARCH AND DEVELOPMENT SERVICES FOR SYNTHESIS AND ANALYSIS OF MEDICAL THERAPEUTICS, ANTIMICROBIALS AND THERAPEUTIC DELIVERY SYSTEMS (U.S. CLS. 100 AND 101).

ALAIN LAPTER, EXAMINING ATTORNEY

SN 85-455,248. LAYER-EIGHT, INC., GOSHEN, MA. FILED 10-25-2011.

VERTITECH IT

THE MARK CONSISTS OF STANDARD CHARACTERS WITHOUT CLAIM TO ANY PARTICULAR FONT, STYLE, SIZE, OR COLOR.

NO CLAIM IS MADE TO THE EXCLUSIVE RIGHT TO USE "IT", APART FROM THE MARK AS SHOWN.

FOR IT CONSULTATION AND INTEGRATION SERVICES, COMPUTER TECHNICAL SUPPORT SERVICES, NAMELY, ONSITE AND REMOTE MANAGEMENT OF THE INFORMATION TECHNOLOGY SYSTEMS OF OTHERS INCLUDING OPERATING SYSTEMS, DATABASE SYSTEMS AND WEB APPLICATIONS (U.S. CLS. 100 AND 101).

SIMON TENG, EXAMINING ATTORNEY

SN 85-456,424. QUOTEPRO, INC., CHICAGO, IL. FILED 10-26-2011.

QUOTEPRO

THE MARK CONSISTS OF STANDARD CHARACTERS WITHOUT CLAIM TO ANY PARTICULAR FONT, STYLE, SIZE, OR COLOR.

OWNER OF U.S. REG. NO. 2,111,653.

FOR PROVIDING ON-LINE NON-DOWNLOADABLE SOFTWARE FOR OBTAINING QUOTES IN THE FIELD OF INSURANCE; SOFTWARE AS A SERVICE (SAAS) SERVICES FEATURING SOFTWARE FOR USE IN THE INSURANCE INDUSTRY (U.S. CLS. 100 AND 101).

FIRST USE 6-1-2003; IN COMMERCE 6-1-2003.

MIDGE BUTLER, EXAMINING ATTORNEY

CLASS 42—(Continued).

SN 85-457,061. AVIIR, INC., IRVINE, CA. FILED 10-26-2011.

MIRISK

THE MARK CONSISTS OF STANDARD CHARACTERS WITHOUT CLAIM TO ANY PARTICULAR FONT, STYLE, SIZE, OR COLOR.

FOR MEDICAL LABORATORY SERVICES (U.S. CLS. 100 AND 101).

DOMINIC J. FERRAIUOLO, EXAMINING ATTORNEY

CLASS 42—(Continued).

SN 85-457,259. ZONAR SYSTEMS, INC., SEATTLE, WA. FILED 10-26-2011.

GROUND TRAFFIC CONTROL

THE MARK CONSISTS OF STANDARD CHARACTERS WITHOUT CLAIM TO ANY PARTICULAR FONT, STYLE, SIZE, OR COLOR.

NO CLAIM IS MADE TO THE EXCLUSIVE RIGHT TO USE "TRAFFIC CONTROL", APART FROM THE MARK AS SHOWN.

SEC. 2(F).

FOR PROVIDING A WEB SITE FEATURING TEMPORARY USE OF NON-DOWNLOADABLE SOFTWARE FOR IMPROVING THE EFFICIENCY AND EFFECTIVENESS OF VEHICLE SAFETY, SECURITY, AND MAINTENANCE INSPECTIONS (U.S. CLS. 100 AND 101).

FIRST USE 9-1-2005; IN COMMERCE 9-1-2005.
MATTHEW PAPPAS, EXAMINING ATTORNEY

SN 85-457,093. NATIONAL CINEMEDIA, LLC, CENTENNIAL, CO. FILED 10-26-2011.

MOVIE NIGHT OUT

THE MARK CONSISTS OF STANDARD CHARACTERS WITHOUT CLAIM TO ANY PARTICULAR FONT, STYLE, SIZE, OR COLOR.

OWNER OF U.S. REG. NO. 4,051,772.

NO CLAIM IS MADE TO THE EXCLUSIVE RIGHT TO USE "MOVIE", APART FROM THE MARK AS SHOWN.

FOR COMPUTER SERVICES, NAMELY, HOSTING ON-LINE INTERACTIVE WEBSITE FEATURING ENTERTAINMENT INFORMATION, ON-LINE INTERACTIVE PUBLIC CALENDARS, AND ELECTRONIC MAPS, THAT ALLOWS MULTIPLE PARTICIPANTS TO SHARE ENTERTAINMENT EVENT INFORMATION, EVENT SCHEDULES AND EVENT LOCATIONS; PROVIDING A WEBSITE FEATURING TEMPORARY USE OF NON-DOWNLOADABLE SOFTWARE ALLOWING USERS TO DYNAMICALLY SEARCH AND BROWSE THROUGH MOVIES TO VIEW INFORMATION IN THE FIELD OF MOVIES AND ENTERTAINMENT; COMPUTER SERVICES, NAMELY, CREATING AN ON-LINE COMMUNITY FOR REGISTERED USERS TO SHARE ENTERTAINMENT INFORMATION, PARTICIPATE IN DISCUSSIONS, GET FEEDBACK FROM THEIR PEERS, AND ENGAGE IN SOCIAL NETWORKING; PROVIDING A WEBSITE THROUGH WHICH USERS ARE ABLE TO SELECT, MANAGE AND DOWNLOAD DIGITAL MEDIA CONTENT FROM THE INTERNET DIRECTLY TO COMPUTERS, MEDIA PLAYERS AND MOBILE DEVICES (U.S. CLS. 100 AND 101).

FIRST USE 4-13-2010; IN COMMERCE 9-7-2010.

WILLIAM VERHOSEK, EXAMINING ATTORNEY

SN 85-462,823. GYRODATA INCORPORATED, HOUSTON, TX. FILED 11-2-2011.

GWD70

THE MARK CONSISTS OF STANDARD CHARACTERS WITHOUT CLAIM TO ANY PARTICULAR FONT, STYLE, SIZE, OR COLOR.

OWNER OF U.S. REG. NO. 3,993,516.

FOR CONDUCTING WELLBORE SURVEY SERVICES FOR THE OIL AND GAS, ENERGY, MINING, ENVIRONMENTAL AND CONSTRUCTION INDUSTRIES; PROVIDING WELLBORE MAPPING SERVICES; PROVIDING ELECTRONIC WELLBORE DATA COLLECTION SERVICES, NAMELY, PROVIDING SERVICES OF COLLECTING OF WELLBORE DIRECTION AND ORIENTATION DATA FROM WELLBORE MEASUREMENT DEVICES OF OTHERS IN THE OIL AND GAS, ENERGY, MINING, ENVIRONMENTAL AND CONSTRUCTION INDUSTRIES; PROVIDING WELLBORE DATA COLLECTION SERVICES FOR USE IN DIRECTIONAL DRILLING CONTROL IN THE OIL AND GAS, ENERGY, MINING, ENVIRONMENTAL AND CONSTRUCTION INDUSTRIES; PROVIDING WELLBORE DIRECTIONAL DRILLING CONTROL DATA COLLECTION SERVICES IN THE OIL AND GAS WELL DRILLING INDUSTRY, NAMELY, GYROSCOPIC MEASUREMENT OF DIRECTIONAL DRILLING CONTROL DATA, AND COMMUNICATION OF DIRECTIONAL DRILLING CONTROL DATA TO WELLBORE DRILLING OPERATORS; PROVIDING OIL AND GAS WELL RESERVOIR MEASUREMENT SERVICES IN THE OIL AND GAS WELL INDUSTRY, NAMELY, GYROSCOPIC MEASUREMENT OF DIRECTION AND ORIENTATION OF WELLBORES IN RELATION TO OIL AND GAS WELL RESERVOIR FORMATIONS (U.S. CLS. 100 AND 101).

FIRST USE 2-21-2011; IN COMMERCE 2-21-2011.

RUSS HERMAN, EXAMINING ATTORNEY

CLASS 42—(Continued).

SN 85-462,901. GYRODATA INCORPORATED, HOUSTON, TX. FILED 11-2-2011.

GWD40

THE MARK CONSISTS OF STANDARD CHARACTERS WITHOUT CLAIM TO ANY PARTICULAR FONT, STYLE, SIZE, OR COLOR.

OWNER OF U.S. REG. NO. 3,993,516.

FOR CONDUCTING WELLBORE SURVEY SERVICES FOR THE OIL AND GAS, ENERGY, MINING, ENVIRONMENTAL AND CONSTRUCTION INDUSTRIES; PROVIDING WELLBORE MAPPING SERVICES; PROVIDING ELECTRONIC WELLBORE DATA COLLECTION SERVICES, NAMELY, PROVIDING SERVICES OF COLLECTING OF WELLBORE DIRECTION AND ORIENTATION DATA FROM WELLBORE MEASUREMENT DEVICES OF OTHERS IN THE OIL AND GAS, ENERGY, MINING, ENVIRONMENTAL AND CONSTRUCTION INDUSTRIES; PROVIDING WELLBORE DATA COLLECTION SERVICES FOR USE IN DIRECTIONAL DRILLING CONTROL IN THE OIL AND GAS, ENERGY, MINING, ENVIRONMENTAL AND CONSTRUCTION INDUSTRIES; PROVIDING WELLBORE DIRECTIONAL DRILLING CONTROL DATA COLLECTION SERVICES IN THE OIL AND GAS WELL DRILLING INDUSTRY, NAMELY, GYROSCOPIC MEASUREMENT OF DIRECTIONAL DRILLING CONTROL DATA, AND COMMUNICATION OF DIRECTIONAL DRILLING CONTROL DATA TO WELLBORE DRILLING OPERATORS; PROVIDING OIL AND GAS WELL RESERVOIR MEASUREMENT SERVICES IN THE OIL AND GAS WELL INDUSTRY, NAMELY, GYROSCOPIC MEASUREMENT OF DIRECTION AND ORIENTATION OF WELLBORES IN RELATION TO OIL AND GAS WELL RESERVOIR FORMATIONS (U.S. CLS. 100 AND 101).

FIRST USE 7-1-2011; IN COMMERCE 7-1-2011.
RUSS HERMAN, EXAMINING ATTORNEY

SN 85-467,775. WINNING OPINION LLC, DBA THEWINNINGOPINION.COM, THOUSAND OAKS, CA. FILED 11-8-2011.

Winning Opinion

THE MARK CONSISTS OF STANDARD CHARACTERS WITHOUT CLAIM TO ANY PARTICULAR FONT, STYLE, SIZE, OR COLOR.

FOR PROVIDING AN INTERACTIVE WEBSITE FEATURING TECHNOLOGY THAT ALLOWS USERS TO REVIEW VARIOUS PRINT, PHOTOGRAPHIC, GRAPHIC IMAGE, AND AUDIO AND VIDEO CONTENT AND UTILIZE A CUSTOM TEMPLATE TO PROVIDE INPUT, LIKES, DISLIKES, EDITS, CHANGES, MODIFICATIONS, OPINIONS, SUGGESTIONS, AND COMMENTS AND ENGAGE IN SOCIAL, BUSINESS AND COMMUNITY NETWORKING AND HAVE THE OPPORTUNITY OF WINNING MONEY AND VARIOUS PRIZES (U.S. CLS. 100 AND 101).

HEATHER BIDDULPH, EXAMINING ATTORNEY

CLASS 42—(Continued).

SN 85-479,657. WEST CORPORATION, OMAHA, NE. FILED 11-23-2011.

Interchange

THE MARK CONSISTS OF STANDARD CHARACTERS WITHOUT CLAIM TO ANY PARTICULAR FONT, STYLE, SIZE, OR COLOR.

FOR COMPUTER SERVICES, NAMELY, CREATING AN ON-LINE COMMUNITY FOR REGISTERED USERS TO NETWORK WITH OTHER SMALL BUSINESSES AND ENTERPRISE CUSTOMERS; VISIT VIRTUAL SMALL BUSINESS BOOTHS; PARTICIPATE IN DISCUSSIONS, FORUMS AND WEBINARS; WATCH KEYNOTE SPEECHES AND VIDEOS; VIEW JOB BOARDS; AND ENGAGE IN ON-LINE SOCIAL NETWORKING IN THE FIELD OF SMALL BUSINESS (U.S. CLS. 100 AND 101).

ANNE MADDEN, EXAMINING ATTORNEY

SN 85-493,719. AARON BELYEA, BOSTON, MA. FILED 12-13-2011.



NO CLAIM IS MADE TO THE EXCLUSIVE RIGHT TO USE "DESIGN", APART FROM THE MARK AS SHOWN.

THE MARK CONSISTS OF A BUILDING WITH THE LETTERS "ABC" ABOVE THE BUILDING ENCLOSED BY A CIRCLE, THE WORDS "ALPHABET ARM DESIGN" BELOW THE BUILDING AND A LINE BETWEEN THE DESIGN OF THE BUILDING AND THE WORDING "ALPHABET ARM DESIGN".

FOR GRAPHIC ART DESIGN; GRAPHIC ILLUSTRATION SERVICES FOR OTHERS (U.S. CLS. 100 AND 101).
FIRST USE 11-1-2001; IN COMMERCE 11-1-2001.
JANET LEE, EXAMINING ATTORNEY

CLASS 42—(Continued).

SN 85-497,698. INXPO, INC., CHICAGO, IL. FILED 12-16-2011.

The Power to Reach

THE MARK CONSISTS OF STANDARD CHARACTERS WITHOUT CLAIM TO ANY PARTICULAR FONT, STYLE, SIZE, OR COLOR.

FOR PROVIDING THE TEMPORARY USE OF NON-DOWNLOADABLE, WEB-BASED COMPUTER SOFTWARE FOR OFFERING, ORGANIZING AND CONDUCTING INTERACTIVE EVENTS VIA THE INTERNET, NAMELY, MEETINGS, CONFERENCES, SYMPOSIUMS, SEMINARS, TRADE SHOWS, CAREER FAIRS, EDUCATIONAL PROGRAMS, TRAINING PROGRAMS, LEAD GENERATION EVENTS AND CORPORATE COMMUNICATION, FOR PROVIDING WEBCASTS AND DELIVERING LIVE AND PRE-RECORDED AUDIO-VISUAL AND MULTIMEDIA CONTENT VIA THE INTERNET, FOR CREATING AND OFFERING VIRTUAL OFFICE SPACES, VIRTUAL COMMUNITY SPACES OR VIRTUAL EDUCATIONAL SPACES FOR THE PURPOSE OF REPLICATING A PHYSICAL ENVIRONMENT ON THE INTERNET, AND FOR REAL TIME COMMUNICATION AND COLLABORATION AMONG USERS IN CONNECTION WITH EACH OF THE ABOVE (U.S. CLS. 100 AND 101).

FIRST USE 1-6-2012; IN COMMERCE 1-6-2012.

JOHN DWYER, EXAMINING ATTORNEY

SN 85-499,355. CULTURE JAM, INC., VENICE, CA. FILED 12-19-2011.

SOCIAL STORM

THE MARK CONSISTS OF STANDARD CHARACTERS WITHOUT CLAIM TO ANY PARTICULAR FONT, STYLE, SIZE, OR COLOR.

NO CLAIM IS MADE TO THE EXCLUSIVE RIGHT TO USE "SOCIAL", APART FROM THE MARK AS SHOWN.

FOR PROVIDING A WEBSITE FEATURING NON-DOWNLOADABLE SOFTWARE FOR THIRD PARTY PROMOTERS TO DEVELOP OR DESIGN THE SOFTWARE NECESSARY TO DEVELOP SOCIAL MEDIA VIRAL MARKETING CAMPAIGNS TO ENABLE BUILDING SOCIAL MEDIA VIRAL PROMOTIONAL MARKETING CAMPAIGNS FOR THEIR COMPANY, CLIENT, BRAND OR ARTIST ON THEIR OWN, WITHOUT THE NEED FOR AN INTERMEDIARY TO DEVELOP OR DESIGN THE SOFTWARE NECESSARY TO DEVELOP SOCIAL MEDIA VIRAL MARKETING CAMPAIGNS; COMPUTER SOFTWARE DEVELOPMENT IN THE FIELD OF MOBILE APPLICATIONS (U.S. CLS. 100 AND 101).

KRISTIN DAHLING, EXAMINING ATTORNEY

CLASS 42—(Continued).

SN 85-506,610. CSG SYSTEMS, INC., ENGLEWOOD, CO. FILED 12-30-2011.

AGENTHUB

THE MARK CONSISTS OF STANDARD CHARACTERS WITHOUT CLAIM TO ANY PARTICULAR FONT, STYLE, SIZE, OR COLOR.

FOR APPLICATION SERVICE PROVIDER (ASP) FEATURING SOFTWARE FOR USE IN PROVIDING CUSTOMER INTERACTION MANAGEMENT, CROSS-PLATFORM CONTACT CENTER COMMUNICATIONS, OPERATIONS AND MANAGEMENT, AND CONTACT CENTER AND TELECOMMUNICATIONS SYNCHRONIZED FUNCTIONALITY; PROVIDING TEMPORARY USE OF ONLINE NON-DOWNLOADABLE COMPUTER SOFTWARE FOR USE IN THE FIELD OF CONTACT CENTER OPERATIONS AND OUTSOURCING AND MANAGING BUSINESS PROCESSES; PROVIDING TEMPORARY USE OF NON-DOWNLOADABLE COMPUTER DATABASE MANAGEMENT SOFTWARE AND COMMUNICATIONS SOFTWARE TO ENABLE BETTER EFFICIENCY, COMMUNICATION AND VISIBILITY BETWEEN BUSINESSES AND THEIR CONTACT CENTER RESOURCES; PROVIDING TEMPORARY USE OF NON-DOWNLOADABLE COMPUTER SOFTWARE FOR INTEGRATING DIFFERENT CONTACT CENTER APPLICATIONS SO THAT THEY MAY WORK TOGETHER; CUSTOMIZATION AND IMPLEMENTATION OF COMPUTER SOFTWARE FOR CONTACT CENTER MANAGEMENT; COMPUTER PROGRAMMING SERVICES FOR OTHERS; COMPUTER CONSULTATION SERVICES; CONSULTING SERVICES IN THE FIELD OF DESIGN, DEVELOPMENT, IMPLEMENTATION, EVALUATION, OPERATION AND USE OF COMPUTER SOFTWARE, COMPUTER NETWORKS, AND WEBSITES (U.S. CLS. 100 AND 101).

FIRST USE 6-7-2011; IN COMMERCE 11-1-2011.

ANDREW LEASER, EXAMINING ATTORNEY

SN 85-513,128. INXPO, INC., CHICAGO, IL. FILED 1-10-2012.

VXPlatform

THE MARK CONSISTS OF STANDARD CHARACTERS WITHOUT CLAIM TO ANY PARTICULAR FONT, STYLE, SIZE, OR COLOR.

FOR COMPUTER SERVICES, NAMELY, PROVIDING ACCESS AND TEMPORARY USE OF NON-DOWNLOADABLE COMPUTER SOFTWARE FOR THE PURPOSE OF CONDUCTING INTERACTIVE VIRTUAL AND VIRTUAL-LIVE HYBRID BUSINESS MEETINGS, TRADESHOWS, WEBCASTS CONFERENCES, SYMPOSIUMS, EXPOSITIONS, SEMINARS, TRAINING PROGRAMS, ONLINE EDUCATION PROGRAMS, PRODUCT LAUNCHES, CORPORATE BRIEFINGS, JOB FAIRS, LEAD GENERATION ACTIVITIES, INDUSTRY NETWORKING PROGRAMS, BUSINESS NETWORKING PROGRAMS, VIDEO STREAMING, ONLINE EDUCATION PROGRAMS AND COMBINATIONS THEREOF (U.S. CLS. 100 AND 101).

FIRST USE 1-12-2011; IN COMMERCE 1-12-2011.

JOHN DWYER, EXAMINING ATTORNEY

CLASS 42—(Continued).

SN 85-513,166. INXPO, INC., CHICAGO, IL. FILED 1-10-2012.

VX

THE MARK CONSISTS OF STANDARD CHARACTERS WITHOUT CLAIM TO ANY PARTICULAR FONT, STYLE, SIZE, OR COLOR.

FOR COMPUTER SERVICES, NAMELY, PROVIDING TEMPORARY USE OF NON-DOWNLOADABLE COMPUTER SOFTWARE FOR THE PURPOSE OF CONDUCTING INTERACTIVE VIRTUAL AND VIRTUAL-LIVE HYBRID BUSINESS MEETINGS, TRADESHOWS, CONFERENCES, WEBCASTS, SYMPOSIUMS, EXPOSITIONS, SEMINARS, TRAINING PROGRAMS, ONLINE EDUCATION PROGRAMS, PRODUCT LAUNCHES, CORPORATE BRIEFINGS, JOB FAIRS, LEAD GENERATION ACTIVITIES, INDUSTRY NETWORKING PROGRAMS, BUSINESS NETWORKING PROGRAMS, VIDEO STREAMING, ONLINE EDUCATION PROGRAMS AND COMBINATIONS THEREOF (U.S. CLS. 100 AND 101).

FIRST USE 1-12-2011; IN COMMERCE 1-12-2011.

JOHN DWYER, EXAMINING ATTORNEY

CLASS 43—HOTEL AND RESTAURANT SERVICES

SN 77-756,161. MAXIMA INTERNATIONAL LLC, WASHINGTON, DC. FILED 6-10-2009.

CAFE RAVEN

THE MARK CONSISTS OF STANDARD CHARACTERS WITHOUT CLAIM TO ANY PARTICULAR FONT, STYLE, SIZE, OR COLOR.

NO CLAIM IS MADE TO THE EXCLUSIVE RIGHT TO USE "CAFE", APART FROM THE MARK AS SHOWN.

FOR BAR, CAFE, AND RESTAURANT SERVICES; RESTAURANT CARRY-OUT SERVICES; CATERING SERVICES; PROVISION OF FOOD AND BEVERAGES (U.S. CLS. 100 AND 101).

KATHY DE JONGE, EXAMINING ATTORNEY

CLASS 43—(Continued).

SN 77-756,163. MAXIMA INTERNATIONAL LLC, WASHINGTON, DC. FILED 6-10-2009.



NO CLAIM IS MADE TO THE EXCLUSIVE RIGHT TO USE "CAFE", APART FROM THE MARK AS SHOWN.

THE NAME(S), PORTRAIT(S), AND/OR SIGNATURE(S) SHOWN IN THE MARK DOES NOT IDENTIFY A PARTICULAR LIVING INDIVIDUAL.

THE MARK CONSISTS OF A DARK COLORED CIRCLE; PROMINENTLY FEATURED IN THE CENTER OF THE CIRCLE IS A LIGHT COLORED STAR SHAPE; ON EITHER SIDE OF THE STAR IN THE TOP PORTION OF THE CIRCLE ARE A TOTAL OF SIX FLAGS, THREE ON EACH SIDE OF THE STAR POINT; IN THE BOTTOM LEFT PORTION OF THE CIRCLE IS A DEPICTION OF A MAN WEARING A SOMBRERO AND PONCHO STANDING IN FRONT OF A SOUTHWESTERN STYLE BUILDING; IN THE BOTTOM RIGHT HAND PORTION OF THE CIRCLE IS A DEPICTION OF AN AMERICAN INDIAN WEARING A FEATHERED HEADDRESS STANDING IN FRONT OF TEEPEES; IN THE BOTTOM CENTER PORTION OF THE CIRCLE IS A DEPICTION OF A MAN WEARING A PLAID, RUFFLED COLLARED SHIRT AND A WIDE, FABRIC HEADBAND; THE WORD "CAFE" IN DARK TEXT IS POSITIONED VERTICALLY IN THE TOP POINT OF THE STAR AND THE WORD "RAVEN" IN DARK TEXT IS PROMINENTLY FEATURED HORIZONTALLY ACROSS THE CENTER OF THE STAR AND CIRCLE.

FOR BAR, CAFE, AND RESTAURANT SERVICES; RESTAURANT CARRY-OUT SERVICES; CATERING SERVICES; PROVISION OF FOOD AND BEVERAGES (U.S. CLS. 100 AND 101).

KATHY DE JONGE, EXAMINING ATTORNEY

SN 77-863,299. VICTORIA PARTNERS, LAS VEGAS, NV. FILED 11-2-2009.

HOTEL32

THE MARK CONSISTS OF STANDARD CHARACTERS WITHOUT CLAIM TO ANY PARTICULAR FONT, STYLE, SIZE, OR COLOR.

FOR HOTEL SERVICES (U.S. CLS. 100 AND 101).

STEVEN R. FINE, EXAMINING ATTORNEY

CLASS 43—(Continued).

SN 85-194,198. A.A.K. LEARNING CENTERS, LLC, LIBERTY TOWNSHIP, OH. FILED 12-9-2010.



NO CLAIM IS MADE TO THE EXCLUSIVE RIGHT TO USE "KIDS" AND "A GREEN CHILDCARE AND LEARNING CENTER", APART FROM THE MARK AS SHOWN.

THE MARK CONSISTS OF A CHILD HOLDING A BEACH BALL WITH THE LITERAL ELEMENTS "ALL ABOUT KIDS A GREEN CHILDCARE AND LEARNING CENTER" IN STYLIZED TEXT.

FOR CHILD CARE CENTERS NOT INCLUDING IN-HOME TUTORING IN ACADEMIC SUBJECTS AND NOT INCLUDING SPORTS FACILITIES FOR CHILDREN FEATURING GYMNASTICS, CHEERLEADING, DANCE, SWIMMING, MARTIAL ARTS, AND SOCCER; CHILD CARE SERVICES NOT INCLUDING IN-HOME TUTORING IN ACADEMIC SUBJECTS AND NOT INCLUDING SPORTS FACILITIES FOR CHILDREN FEATURING GYMNASTICS, CHEERLEADING, DANCE, SWIMMING, MARTIAL ARTS, AND SOCCER (U.S. CLS. 100 AND 101).

FIRST USE 8-8-2005; IN COMMERCE 8-8-2005.
LAKEISHA LEWIS, EXAMINING ATTORNEY

SN 85-236,956. TEXAS TACO CABANA, L.P., SAN ANTONIO, TX. FILED 2-8-2011.

Taco Cabana Chips In

THE MARK CONSISTS OF STANDARD CHARACTERS WITHOUT CLAIM TO ANY PARTICULAR FONT, STYLE, SIZE, OR COLOR.

OWNER OF U.S. REG. NOS. 1,581,970, 1,978,245 AND OTHERS.

NO CLAIM IS MADE TO THE EXCLUSIVE RIGHT TO USE "TACO", APART FROM THE MARK AS SHOWN.

FOR FAST FOOD RESTAURANT SPECIALIZING IN MEXICAN FOOD (U.S. CLS. 100 AND 101).

FIRST USE 12-15-2010; IN COMMERCE 12-15-2010.
MICHAEL SOUDERS, EXAMINING ATTORNEY

CLASS 43—(Continued).

SN 85-271,154. LIAO, JUI YU, IRVINE, CA. FILED 3-18-2011.



THE COLOR(S) RED AND YELLOW IS/ARE CLAIMED AS A FEATURE OF THE MARK.

THE MARK CONSISTS OF A RED RECTANGLE CARRYING A STYLIZED DESIGN ON THE LEFT SIDE OF A PLATE AND TWO CROSSED CHOPSTICKS LAYING ACROSS THE PLATE WHICH ARE COMPRISED OF AN INCOMPLETE YELLOW CIRCLE AND TWO STRAIGHT YELLOW LINES DRAWN WITH THE TEXTURE OF A PAINT-STROKE. THE WORD "HAN" APPEARS TO THE RIGHT OF THE LOGO IN BROAD PAINT-STROKE LIKE YELLOW SCRIPT.

THE WORDING "HAN" HAS NO MEANING IN A FOREIGN LANGUAGE.

FOR CARRY-OUT RESTAURANTS; FAST-FOOD RESTAURANTS; RESTAURANT SERVICES (U.S. CLS. 100 AND 101).

FIRST USE 1-1-2010; IN COMMERCE 1-1-2010.
ANTHONY RINKER, EXAMINING ATTORNEY

SN 85-282,848. D'AMICO ENTERPRISES, INC., HOUSTON, TX. FILED 3-31-2011.

NASH D'AMICO'S ITALIAN MARKET CAFE

THE MARK CONSISTS OF STANDARD CHARACTERS WITHOUT CLAIM TO ANY PARTICULAR FONT, STYLE, SIZE, OR COLOR.

NO CLAIM IS MADE TO THE EXCLUSIVE RIGHT TO USE "ITALIAN MARKET CAFE", APART FROM THE MARK AS SHOWN.

THE NAME(S), PORTRAIT(S), AND/OR SIGNATURE(S) SHOWN IN THE MARK IDENTIFIES "NASH D'AMICO", WHOSE CONSENT(S) TO REGISTER IS MADE OF RECORD.

FOR BAR AND RESTAURANT SERVICES (U.S. CLS. 100 AND 101).

DEBRA LEE, EXAMINING ATTORNEY

CLASS 43—(Continued).

SN 85-290,691. STACHURA, MICHAEL, SMYRNA, GA. FILED 4-8-2011.

University Draft House UDH

THE MARK CONSISTS OF STANDARD CHARACTERS WITHOUT CLAIM TO ANY PARTICULAR FONT, STYLE, SIZE, OR COLOR.

NO CLAIM IS MADE TO THE EXCLUSIVE RIGHT TO USE "DRAFT HOUSE", APART FROM THE MARK AS SHOWN.

FOR RESTAURANT AND BAR SERVICES (U.S. CLS. 100 AND 101).

MICHELLE DUBOIS, EXAMINING ATTORNEY

SN 85-296,980. DONNAGIO'S, PALISADES PARK, NJ. FILED 4-15-2011.

**DONNAGIO'S PIZZERIA
"QUALITY AND QUANTITY"
SINCE 1965**

THE MARK CONSISTS OF STANDARD CHARACTERS WITHOUT CLAIM TO ANY PARTICULAR FONT, STYLE, SIZE, OR COLOR.

NO CLAIM IS MADE TO THE EXCLUSIVE RIGHT TO USE "PIZZERIA", "QUALITY AND QUANTITY" SINCE 1965", APART FROM THE MARK AS SHOWN.

FOR TAKE-OUT RESTAURANT SERVICES ; RESTAURANTS FEATURING HOME DELIVERY ; RESTAURANT SERVICES (U.S. CLS. 100 AND 101).

FIRST USE 9-4-2004; IN COMMERCE 9-4-2004.
EDWARD NELSON, EXAMINING ATTORNEY

SN 85-299,005. HULA DOG, LLC, WINDERMERE, FL. FILED 4-19-2011.



NO CLAIM IS MADE TO THE EXCLUSIVE RIGHT TO USE "DOG" AND "AUTHENTIC HAWAIIAN-STYLE HOT DOGS", APART FROM THE MARK AS SHOWN.

THE COLOR(S) RED, ORANGE, YELLOW, PEACH, PINK, GREEN, WHITE, BLACK AND BROWN IS/ARE CLAIMED AS A FEATURE OF THE MARK.

THE MARK CONSISTS OF AN IMAGE OF A PEACH-COLORED CARTOON-LIKE DOG, WITH A BROWN NOSE,

CLASS 43—(Continued).

RED TONGUE, WHITE STOMACH AND TIP OF TAIL, AND PINK INSIDE THE EARS. THE DOG IS WEARING A LEI WITH ORANGE FLOWERS, BLACK SUNGLASSES, GREEN GRASS SKIRT AND BROWN SANDALS. HE APPEARS TO BE RUNNING AND CARRYING A YELLOW SURFBOARD WITH RED STRIPES, AND A HOT DOG IN RED, PEACH AND BROWN, WITH A BITE OUT OF IT. THE STYLIZED WORDS "KONA DOG", IN RED, AND "AUTHENTIC HAWAIIAN-STYLE HOT DOGS", IN BLACK, APPEAR UNDERNEATH THE DOG. ORANGE FLOWERS APPEAR AT THE FRONT AND END OF THE WORDS "KONA DOG". FOR RESTAURANT SERVICES (U.S. CLS. 100 AND 101).

FIRST USE 4-19-2011; IN COMMERCE 4-19-2011.
KELLEY WELLS, EXAMINING ATTORNEY

SN 85-299,114. PIRTLE, CORDELL, MEMPHIS, TN. AND PIRTLE, TAWANDA, MEMPHIS, TN. FILED 4-19-2011.



NO CLAIM IS MADE TO THE EXCLUSIVE RIGHT TO USE "CHICKEN", APART FROM THE MARK AS SHOWN. THE NAME "JACK PIRTLE" DOES NOT IDENTIFY A PARTICULAR LIVING INDIVIDUAL.

THE MARK CONSISTS OF "JACK PIRTLE'S" ABOVE A HALF CIRCLE WITH A CHICKEN INSIDE THE HALF CIRCLE WEARING A COWBOY HAT; UNDERNEATH THE HALF CIRCLE ARE THE WORDS "IT'S DOWN HOME DELICIOUS".

FOR RESTAURANT SERVICES (U.S. CLS. 100 AND 101).

FIRST USE 12-1-1994; IN COMMERCE 12-1-1994.
ALEX KEAM, EXAMINING ATTORNEY

CLASS 43—(Continued).

SN 85-308,569. KNOWLEDGE BRIDGE INC., OTTAWA, ONTARIO, CANADA, FILED 4-29-2011.

CLASS 43—(Continued).

SN 85-311,947. LDRV HOLDINGS CORP., SEFFNER, FL. FILED 5-4-2011.

23-18

EXIT 10

THE MARK CONSISTS OF STANDARD CHARACTERS WITHOUT CLAIM TO ANY PARTICULAR FONT, STYLE, SIZE, OR COLOR.

FOR OPERATION OF HOTEL, MOTEL, LODGING, INN, RESORT AND CONVENTION SERVICES, NAMELY, MAKING HOTEL AND ACCOMMODATION RESERVATIONS AND BOOKINGS FOR OTHERS, MAKING CONFERENCE AND MEETING ROOM RESERVATIONS FOR OTHERS, PROVIDING INFORMATION REGARDING ROOM BOOKING, PROVIDING ACCOMMODATION RATINGS, REVIEWS, AND RECOMMENDATIONS, PROVIDING INFORMATION REGARDING FACILITIES ACCOMMODATION AVAILABILITY FOR BANQUETS, SPECIAL OCCASIONS AND CONVENTIONS; OPERATION OF RESTAURANT, CATERING, BAR, AND LOUNGE SERVICES, NAMELY, PROVIDING BAR, RESTAURANT, AND COCKTAIL LOUNGE SERVICES, PROVIDING FOOD, DRINK, AND TEMPORARY ACCOMMODATION SERVICES (U.S. CLS. 100 AND 101).
SUE LAWRENCE, EXAMINING ATTORNEY

THE MARK CONSISTS OF STANDARD CHARACTERS WITHOUT CLAIM TO ANY PARTICULAR FONT, STYLE, SIZE, OR COLOR.

FOR RESTAURANT, BAR, AND TAKE-OUT FOOD RESTAURANT SERVICES (U.S. CLS. 100 AND 101).
ALEX KEAM, EXAMINING ATTORNEY

SN 85-308,621. KNOWLEDGE BRIDGE INC., OTTAWA, ONTARIO, CANADA, FILED 4-29-2011.

SN 85-352,179. PAPPAS RESTAURANTS, INC., HOUSTON, TX. FILED 6-21-2011.

HAMMOCK TRAVELER



THE MARK CONSISTS OF STANDARD CHARACTERS WITHOUT CLAIM TO ANY PARTICULAR FONT, STYLE, SIZE, OR COLOR.

NO CLAIM IS MADE TO THE EXCLUSIVE RIGHT TO USE "TRAVELER", APART FROM THE MARK AS SHOWN.

FOR OPERATION OF HOTEL, MOTEL, LODGING, INN, RESORT AND CONVENTION SERVICES, NAMELY, MAKING HOTEL AND ACCOMMODATION RESERVATIONS AND BOOKINGS FOR OTHERS, MAKING CONFERENCE AND MEETING ROOM RESERVATIONS FOR OTHERS, PROVIDING INFORMATION REGARDING ROOM BOOKING, PROVIDING ACCOMMODATION RATINGS, REVIEWS, AND RECOMMENDATIONS, PROVIDING INFORMATION REGARDING FACILITIES ACCOMMODATION AVAILABILITY FOR BANQUETS, SPECIAL OCCASIONS AND CONVENTIONS; OPERATION OF RESTAURANT, CATERING, BAR, AND LOUNGE SERVICES, NAMELY, PROVIDING BAR, RESTAURANT, AND COCKTAIL LOUNGE SERVICES, PROVIDING FOOD, DRINK, AND TEMPORARY ACCOMMODATION SERVICES (U.S. CLS. 100 AND 101).
SUE LAWRENCE, EXAMINING ATTORNEY

NO CLAIM IS MADE TO THE EXCLUSIVE RIGHT TO USE "AMERICA'S HAMBURGER", APART FROM THE MARK AS SHOWN.

THE MARK CONSISTS OF A STYLIZED DEPICTION OF A HAMBURGER ON A PLATE APPEARING WITHIN A CIRCLE UPON WHICH THE WORDS "AMERICA'S HAMBURGER" AND TWO DECORATIVE STARS ARE DEPICTED.

FOR RESTAURANT SERVICES (U.S. CLS. 100 AND 101).
FIRST USE 6-26-2007; IN COMMERCE 6-26-2007.
VERNA BETH RIRIE, EXAMINING ATTORNEY

CLASS 43—(Continued).

SN 85-370,327. GELFAND, KEVIN, SAN DIEGO, CA. FILED 7-13-2011.

Shake Your Shape

THE MARK CONSISTS OF STANDARD CHARACTERS WITHOUT CLAIM TO ANY PARTICULAR FONT, STYLE, SIZE, OR COLOR.

NO CLAIM IS MADE TO THE EXCLUSIVE RIGHT TO USE "SHAKE", APART FROM THE MARK AS SHOWN.

FOR RESTAURANT SERVICES FEATURING SMOOTHIES, PROTEIN DRINKS, AND NUTRITIONAL ENERGY BARS (U.S. CLS. 100 AND 101).

FIRST USE 9-1-2010; IN COMMERCE 9-1-2010.
ALLISON HOLTZ, EXAMINING ATTORNEY

SN 85-372,977. MUCKLESHOOT INDIAN TRIBE, AUBURN, WA. FILED 7-15-2011.

COYABA GRILL

THE MARK CONSISTS OF STANDARD CHARACTERS WITHOUT CLAIM TO ANY PARTICULAR FONT, STYLE, SIZE, OR COLOR.

NO CLAIM IS MADE TO THE EXCLUSIVE RIGHT TO USE "GRILL", APART FROM THE MARK AS SHOWN.

THE WORDING "COYABA" HAS NO MEANING IN A FOREIGN LANGUAGE.

FOR BAR AND RESTAURANT SERVICES (U.S. CLS. 100 AND 101).

FIRST USE 7-23-2009; IN COMMERCE 7-23-2009.
KATHY DE JONGE, EXAMINING ATTORNEY

SN 85-377,847. PACIFIC RESORTS INVESTMENTS LIMITED, ASPEN, CO. FILED 7-21-2011.

WAKAYA

THE MARK CONSISTS OF STANDARD CHARACTERS WITHOUT CLAIM TO ANY PARTICULAR FONT, STYLE, SIZE, OR COLOR.

FOR HOTEL SERVICES, RESORT HOTEL SERVICES AND RESTAURANT SERVICES (U.S. CLS. 100 AND 101).

FIRST USE 2-1-1990; IN COMMERCE 3-1-1991.
GISELLE AGOSTO, EXAMINING ATTORNEY

CLASS 43—(Continued).

SN 85-379,094. KIM, EUN-HEE, SEOUL, REPUBLIC OF KOREA, FILED 7-22-2011.



OWNER OF REPUBLIC OF KOREA REG. NO. 45-0028301, DATED 7-14-2009, EXPIRES 7-14-2019.

THE MARK CONSISTS OF AN OUTLINED CIRCLE. INSIDE THE CIRCLE IS ANOTHER DARK SHADED CIRCLE WITH A CURVED TOP PORTION. THE INNER CIRCLE CONTAINS THE WORDING "COFFINE" ABOVE A HORIZONTAL LINE AND THE WORDING "GURUNARU".

THE WORDING "GURUNARU" HAS NO MEANING IN A FOREIGN LANGUAGE.

FOR COFFEE BAR, COFFEE SHOP, WINE BAR, CAFÉ SERVICES, CAFETERIA SERVICES, BAR SERVICES, RESTAURANTS, SELF SERVICE RESTAURANTS, SNACK BAR SERVICES (U.S. CLS. 100 AND 101).

TARAH HARDY, EXAMINING ATTORNEY

SN 85-406,717. MKMG LLC, ALEXANDRIA, VA. FILED 8-25-2011.



NO CLAIM IS MADE TO THE EXCLUSIVE RIGHT TO USE "MONGOLIAN GRILL" AND "HEALTHY STIR FRY", APART FROM THE MARK AS SHOWN.

THE COLOR(S) BLACK, WHITE, RED, YELLOW, GRAY AND GOLD IS/ARE CLAIMED AS A FEATURE OF THE MARK.

THE MARK CONSISTS OF THE WORDING "MIGHTY KHAN'S" IN RED LETTERING, WITH THE LETTER "Y" AND THE LETTERS "AN'S" OUTLINED IN WHITE, AND PARTIALLY OVERLAPPING THE DESIGN OF RED AND YELLOW FIRE IN A BOWL WHICH IS GRAY WITH WHITE SHADING AND OUTLINED IN BLACK. BEHIND THE BOWL IS A SEAL WHICH IS YELLOW IN THE CENTER AND GOLD ON THE OUTER EDGE AND LINED IN BLACK. THE SEAL HAS A BLACK MISCELLANEOUS DESIGN LINING THE ENTIRE EDGE AND BLACK MISCELLANEOUS TRIANGULAR SHAPES IN THE CENTER OF THE SEAL PARTIALLY HIDDEN BY THE DESIGN OF THE FIRE. THE WORDING "MONGOLIAN GRILL", IN BLACK LETTERING, APPEARS ALONG THE TOP OF THE SEAL AND THE WORDING "HEALTHY STIR FRY" IN BLACK LETTERING APPEARS ALONG THE BOTTOM.

FOR RESTAURANT SERVICES (U.S. CLS. 100 AND 101).

WENDY GOODMAN, EXAMINING ATTORNEY

CLASS 43—(Continued).

SN 85-407,582. FIVE LOAVES CAFE, INC., CHARLESTON, SC. FILED 8-25-2011.



NO CLAIM IS MADE TO THE EXCLUSIVE RIGHT TO USE "CAFE", APART FROM THE MARK AS SHOWN.

THE MARK CONSISTS OF A FANCIFUL DESIGN OF A SKILLET WITH FIVE LOAVES OF BREAD IN THE SKILLET, ALONG WITH A STEAMING BOWL OF SOUP. THE TERMS "FIVE LOAVES" IN A STYLIZED FONT APPEAR ABOVE THE SKILLET AND THE TERM "CAFE" IN A STYLIZED FONT APPEARS BELOW THE SKILLET. ALL OF THE FOREGOING APPEAR INSIDE A DIAMOND.

FOR CATERING SERVICES; RESTAURANT SERVICES; TAKE-OUT RESTAURANT SERVICES (U.S. CLS. 100 AND 101).

FIRST USE 12-31-2002; IN COMMERCE 12-31-2002.
CAROL SPILS, EXAMINING ATTORNEY

CLASS 43—(Continued).

SN 85-419,221. THE RANCH STEAKHOUSE AND SALOON, INC., ANAHEIM, CA. FILED 9-9-2011.

THE RANCH
— RESTAURANT & SALOON —

NO CLAIM IS MADE TO THE EXCLUSIVE RIGHT TO USE "RESTAURANT & SALOON", APART FROM THE MARK AS SHOWN.

THE MARK CONSISTS OF THE WORDS "THE RANCH" ON THE TOP LINE AND A DASH FOLLOWED BY THE WORDS "RESTAURANT & SALOON" AND THEN A SECOND DASH ON THE SECOND LINE.

FOR RESTAURANT AND BAR SERVICES (U.S. CLS. 100 AND 101).

MARY BOAGNI, EXAMINING ATTORNEY

SN 85-416,690. EL TACO GRANDE MEXICAN FOOD, LLC, PLEASANT GROVE, UT. FILED 9-7-2011.

TACOS BERO

THE MARK CONSISTS OF STANDARD CHARACTERS WITHOUT CLAIM TO ANY PARTICULAR FONT, STYLE, SIZE, OR COLOR.

NO CLAIM IS MADE TO THE EXCLUSIVE RIGHT TO USE "TACOS", APART FROM THE MARK AS SHOWN.

THE WORDING "BERO" HAS NO MEANING IN A FOREIGN LANGUAGE.

FOR FAST-FOOD RESTAURANTS; RESTAURANT SERVICES FEATURING MEXICAN FOOD; RESTAURANT SERVICES, INCLUDING SIT-DOWN SERVICE OF FOOD AND TAKE-OUT RESTAURANT SERVICES; RESTAURANT SERVICES, NAMELY, PROVIDING OF FOOD AND BEVERAGES FOR CONSUMPTION ON AND OFF THE PREMISES (U.S. CLS. 100 AND 101).

ALLISON HOLTZ, EXAMINING ATTORNEY

SN 85-420,916. GPG CAPITAL, LLC, LA JOLLA, CA. FILED 9-13-2011.

TAVÉRNA BLU

THE MARK CONSISTS OF STANDARD CHARACTERS WITHOUT CLAIM TO ANY PARTICULAR FONT, STYLE, SIZE, OR COLOR.

NO CLAIM IS MADE TO THE EXCLUSIVE RIGHT TO USE "TAVERNA", APART FROM THE MARK AS SHOWN.

FOR RESTAURANT AND BAR SERVICES (U.S. CLS. 100 AND 101).

FIRST USE 7-31-2011; IN COMMERCE 7-31-2011.

AMY C. KEAN, EXAMINING ATTORNEY

CLASS 43—(Continued).

SN 85-426,316. MTM PLAZA, INC. DBA KORYO KALBI KOREAN BBQ, DALLAS, TX. FILED 9-19-2011.



NO CLAIM IS MADE TO THE EXCLUSIVE RIGHT TO USE "KOREAN BBQ" AND THE NON-LATIN CHARACTERS THAT TRANSLITERATE TO SOOTBOOL APART FROM THE MARK AS SHOWN, APART FROM THE MARK AS SHOWN.

THE COLOR(S) RED,GRAY,WHITE AND BLACK IS/ARE CLAIMED AS A FEATURE OF THE MARK.

THE MARK CONSISTS OF A WHITE CIRCLE WITH A GRAY BORDER:A DRAWING OF THE LEGENDARY BIRD CALLED SAM-JOK-O APPEARS IN GRAY IN THE CIRCLE. SUPERIMPOSED ON THIS DESIGN IS THE TERM "KORYO KALBI KOREAN BBQ" IN RED LETTERING; KOREAN SYMBOL IN BLACK, TRANSLATED IN ENGLISH AS "KORYO KALBI". AND RED COLORED BOX CONTAINING KOREAN SYMBOLS IN WHITE WHICH TRANSLATE INTO ENGLISH AS CHARCOAL.

THE ENGLISH TRANSLATION OF THE WORDS "KORYO KALBI" IN THE MARK IS KOREAN DYNASTY OF "KALBI".

THE NON-LATIN CHARACTERS IN THE MARK TRANSLITERATE TO SOOTBOOL AND THIS MEANS CHARCOAL IN ENGLISH. THE NON-LATIN CHARACTERS IN BLACK SUPERIMPOSED OVER THE GREY CIRCLE TRANSLITERATE TO "KORYO KALBI" AND THIS MEANS " KOREAN DYNASTY OF KALBI" IN ENGLISH.

FOR RESTAURANT (U.S. CLS. 100 AND 101).
HENRY S. ZAK, EXAMINING ATTORNEY

SN 85-429,838. GELATINO IN, AKA PRIME - SANDWICH, BKLYN, NY. FILED 9-22-2011.

PRIME SANDWICH

THE MARK CONSISTS OF STANDARD CHARACTERS WITHOUT CLAIM TO ANY PARTICULAR FONT, STYLE, SIZE, OR COLOR.

NO CLAIM IS MADE TO THE EXCLUSIVE RIGHT TO USE "SANDWICH", APART FROM THE MARK AS SHOWN. SEC. 2(F).

FOR RESTAURANT AND CATERING SERVICES (U.S. CLS. 100 AND 101).

FIRST USE 2-4-2007; IN COMMERCE 2-4-2007.
COURTNEY ALVAREZ, EXAMINING ATTORNEY

CLASS 43—(Continued).

SN 85-430,315. YALIN CHIANG, TAIPEI CITY, TAIWAN, FILED 9-23-2011.



NO CLAIM IS MADE TO THE EXCLUSIVE RIGHT TO USE "ORANGE TEA", APART FROM THE MARK AS SHOWN.

THE MARK CONSISTS OF THE WORDS "ORANGE TEA" WITH CHINESE LETTERS ABOVE IT AND ON THE LEFT HAND SIDE OF THE WORDING, AN ORANGE SLICED IN HALF WITH ANOTHER ORANGE SECTION ABOVE IT WITH A LEAF ON THE LEFT HAND SIDE AND TWO WATER DROPS ON THE RIGHT HAND SIDE.

THE ENGLISH TRANSLATION OF THE MARK IS "HEALTH AND ORANGE WORKSHOP".

THE NON-LATIN CHARACTERS IN THE MARK TRANSLITERATE TO JIANKANG JUZI GONGFANG AND THIS MEANS HEALTH AND ORANGE WORKSHOP IN ENGLISH.

FOR RESTAURANT AND BAR SERVICES; BEVERAGE STORES PROVIDING COFFEE DRINKS AND TEA DRINKS; PREPARATION AND SERVING FOR CARRY OUT FOOD AND BEVERAGES; CARRY-OUT SERVICES; COFFEE AND TEA BARS AND SERVICES; CAFE; FAST FOOD SERVICES; TAKE OUT STORES FOR SERVING BREAKFAST AND BURGERS (U.S. CLS. 100 AND 101).

JACQUELINE A. LAVINE, EXAMINING ATTORNEY

SN 85-433,735. SIXES TAVERN, LLC, CANTON, GA. FILED 9-28-2011.

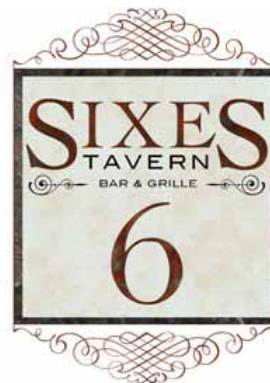

NO CLAIM IS MADE TO THE EXCLUSIVE RIGHT TO USE "TAVERN BAR & GRILLE", APART FROM THE MARK AS SHOWN.

THE COLOR(S) COPPER, GRAY, TAN AND BLACK IS/ ARE CLAIMED AS A FEATURE OF THE MARK.

THE MARK CONSISTS OF ORNAMENTAL FRAMEWORK IN THE SHAPE OF A SQUARE WITH A GREY BORDER AND WITH THE WORDS "SIXES TAVERN" THAT

CLASS 43—(Continued).

ARE COPPER IN COLOR, THE WORDS "BAR & GRILLE" THAT ARE BLACK IN COLOR AND CENTERED BENEATH THE WORD "TAVERN;" THE NUMBER "6" THAT IS COPPER IN COLOR APPEARS BELOW "BAR & GRILLE." THE INTERIOR OF THE SQUARE DESIGN IS SET ON A TAN MARBLE BACKGROUND. ORNAMENTAL LINES THAT ARE BLACK IN COLOR ARE LOCATED ON EACH SIDE OF THE WORDS "BAR & GRILLE." ORNAMENTAL BORDERS THAT ARE COPPER IN COLOR ARE LOCATED OUTSIDE OF THE SQUARE FRAMEWORK.

FOR RESTAURANT AND BAR SERVICES (U.S. CLS. 100 AND 101).

FIRST USE 8-0-2011; IN COMMERCE 8-0-2011.
JEFFREY LOOK, EXAMINING ATTORNEY

CLASS 43—(Continued).

SN 85-442,645. WEIDNER RESORT DEVELOPMENT, INC., LAS VEGAS, NV. FILED 10-7-2011.

SN 85-436,386. SUNG, DAVID, LOS ANGELES, CA. FILED 9-30-2011.

MOANA HAWAIIAN BBQ

THE MARK CONSISTS OF STANDARD CHARACTERS WITHOUT CLAIM TO ANY PARTICULAR FONT, STYLE, SIZE, OR COLOR.

NO CLAIM IS MADE TO THE EXCLUSIVE RIGHT TO USE "HAWAIIAN BBQ", APART FROM THE MARK AS SHOWN.

THE ENGLISH TRANSLATION OF "MOANA" IN THE MARK IS "OCEAN".

FOR RESTAURANT SERVICES FEATURING HAWAIIAN STYLE FOODS AND DRINKS (U.S. CLS. 100 AND 101).

FIRST USE 10-1-2009; IN COMMERCE 10-1-2009.
RICHARD WHITE, EXAMINING ATTORNEY



SN 85-442,019. REVEILLE INDEPENDENT LLC, LOS ANGELES, CA. FILED 10-7-2011.

MASTERCHEF

THE MARK CONSISTS OF STANDARD CHARACTERS WITHOUT CLAIM TO ANY PARTICULAR FONT, STYLE, SIZE, OR COLOR.

OWNER OF U.S. REG. NO. 3,923,964.

FOR RESTAURANT, CAFÉ, BAR AND CATERING SERVICES; MOBILE RESTAURANT AND CAFE SERVICES FOR PROVIDING FOOD AND DRINK; PREPARATION OF FOOD AND BEVERAGES; PROVIDING AN ONLINE COMPUTER DATABASE TO CONSUMERS FEATURING INFORMATION ABOUT RECIPES, INGREDIENTS AND COOKING INFORMATION; PROVIDING INFORMATION, NEWS AND COMMENTARY IN THE FIELD OF DINING; PROVIDING OF FOOD AND DRINK; PROVIDING OF FOOD AND DRINK VIA A MOBILE TRUCK (U.S. CLS. 100 AND 101).

WILLIAM P. SHANAHAN, EXAMINING ATTORNEY

THE MARK CONSISTS OF A RENDERING OF A PAGODA WITH CHINESE CHARACTERS TO THE RIGHT AND THE WORDS "XING GONG TRAVELING PALACE" BELOW THE RENDERING, WITH A HORIZONTAL LINE BETWEEN THE PAGODA AND THE WORDING.

THE ENGLISH TRANSLATION OF "XING GONG" IN THE MARK IS "TRAVELING PALACE".

THE NON-LATIN CHARACTERS IN THE MARK TRANSLITERATE TO "XING GONG" AND THIS MEANS "TRAVELING PALACE" IN ENGLISH.

FOR HOTELS, HOTEL RESORT SERVICES; PROVISION OF CONVENTION, CONFERENCE, EXHIBITION AND MEETING FACILITIES; RESTAURANT AND BAR SERVICES, CAFES; CAFETERIAS; CATERING; CHILD CARE; BUFFET-STYLE RESTAURANTS; COCKTAIL LOUNGES; ARENA SERVICES, NAMELY, PROVIDING FACILITIES FOR SPORTS, CONCERTS, CONVENTIONS AND EXHIBITIONS; SNACK BARS; HOTEL AND RESTAURANT RESERVATION SERVICES (U.S. CLS. 100 AND 101).

ROBIN MITTLER, EXAMINING ATTORNEY

CLASS 43—(Continued).

SN 85-442,672. WEIDNER RESORT DEVELOPMENT, INC., LAS VEGAS, NV. FILED 10-7-2011.



THE MARK CONSISTS OF A RENDERING OF A GATE WITH CHINESE CHARACTERS TO THE RIGHT AND THE WORDS "XING GONG TRAVELING PALACE" BELOW THE RENDERING, WITH HORIZONTAL LINES ABOVE AND BELOW THE WORDING.

THE ENGLISH TRANSLATION OF "XING GONG" IN THE MARK IS "TRAVELING PALACE".

THE NON-LATIN CHARACTERS IN THE MARK TRANSLITERATE TO "XING GONG" AND THIS MEANS "TRAVELING PALACE" IN ENGLISH.

FOR HOTELS, HOTEL RESORT SERVICES; PROVISION OF CONVENTION, CONFERENCE, EXHIBITION AND MEETING FACILITIES; RESTAURANT AND BAR SERVICES, CAFES; CAFETERIAS; CATERING; CHILD CARE; BUFFET-STYLE RESTAURANTS; COCKTAIL LOUNGES; ARENA SERVICES, NAMELY, PROVIDING FACILITIES FOR SPORTS, CONCERTS, CONVENTIONS AND EXHIBITIONS; SNACK BARS; HOTEL AND RESTAURANT RESERVATION SERVICES (U.S. CLS. 100 AND 101).

ROBIN MITTLER, EXAMINING ATTORNEY

SN 85-442,996. ALIMENTOS SAN MARTIN LIMITADA, VIÑA DEL MAR, CHILE, FILED 10-10-2011.

SANTABRASA

THE MARK CONSISTS OF STANDARD CHARACTERS WITHOUT CLAIM TO ANY PARTICULAR FONT, STYLE, SIZE, OR COLOR.

OWNER OF CHILE REG. NO. 673.690, DATED 9-17-2003, EXPIRES 9-17-2013.

THE WORDING "SANTABRASA" HAS NO LITERAL MEANING IN A FOREIGN LANGUAGE. THE LITERAL TRANSLATION OF "SANTA" IS "SAINT" AND THE LITERAL TRANSLATION OF "BRASA" IS "GRILL"; HOWEVER THE WORDS ARE NOT USED TOGETHER IN THE SPOKEN OR WRITTEN LANGUAGE.

FOR BAR SERVICES; CONSULTING SERVICES IN THE FIELD OF CULINARY ARTS; FAST-FOOD RESTAURANT SERVICES; HOTEL SERVICES; MOTEL SERVICES; RESTAURANT AND HOTEL SERVICES; RESTAURANT SERVICES; SELF-SERVICE RESTAURANTS; TAKE-OUT RESTAURANT SERVICES; TEA BARS (U.S. CLS. 100 AND 101).

LINDA POWELL, EXAMINING ATTORNEY

CLASS 43—(Continued).

SN 85-443,212. FAIRVIEW DOME, LLC, CHARLESTON, SC. FILED 10-10-2011.

POE'S TAVERN

THE MARK CONSISTS OF STANDARD CHARACTERS WITHOUT CLAIM TO ANY PARTICULAR FONT, STYLE, SIZE, OR COLOR.

NO CLAIM IS MADE TO THE EXCLUSIVE RIGHT TO USE "TAVERN", APART FROM THE MARK AS SHOWN.

SEC. 2(F).
FOR RESTAURANT SERVICES (U.S. CLS. 100 AND 101).

FIRST USE 6-0-2003; IN COMMERCE 6-0-2003.

JAY BESCH, EXAMINING ATTORNEY

SN 85-444,448. HLT INTERNATIONAL IP LLC, MCLEAN, VA. FILED 10-11-2011.

OWNER OF U.S. REG. NOS. 788,856, 2,478,190 AND OTHERS.

NO CLAIM IS MADE TO THE EXCLUSIVE RIGHT TO USE "INN", APART FROM THE MARK AS SHOWN.

THE MARK CONSISTS OF "HILTON GARDEN INN SATISFACTION" (IN WORDS) WITH A DIVIDING LINE "PROMISE" (WORD) ("O" IN "PROMISE" CONTAINS A LEAF AND A CHECKMARK).

FOR RESTAURANT SERVICES (U.S. CLS. 100 AND 101).

ALLISON HOLTZ, EXAMINING ATTORNEY

CLASS 43—(Continued).

SN 85-444,729. MADE BY HAND, LOUISVILLE, KY. FILED 10-11-2011.



NO CLAIM IS MADE TO THE EXCLUSIVE RIGHT TO USE "TACO", APART FROM THE MARK AS SHOWN.
 THE MARK CONSISTS OF A STYLIZED MEXICAN DAY OF THE DEAD SUGAR SKULL WITH UNIQUE FLORAL AND SUNBURST DETAILS. UNDER THE SKULL IS THE STYLIZED TEXT "TACO PUNK". IN BETWEEN THE WORDS ARE TWO CONCENTRIC CIRCLES WITH PETAL DETAILS INSIDE.
 FOR RESTAURANT SERVICES (U.S. CLS. 100 AND 101).
 FIRST USE 4-6-2011; IN COMMERCE 4-20-2011.
 LINDA POWELL, EXAMINING ATTORNEY

CLASS 43—(Continued).

SN 85-445,518. BOXERS NYC LLC, NEW YORK, NY. FILED 10-12-2011.



NO CLAIM IS MADE TO THE EXCLUSIVE RIGHT TO USE "DC", APART FROM THE MARK AS SHOWN.
 THE MARK CONSISTS OF THE WORD "BOXERS" IN STYLIZED LETTERING, ABOVE WHICH IS AN IMAGE OF A DOG, AND BELOW WHICH ARE THE LETTERS "DC" IN STYLIZED LETTERING LOCATED WITHIN A RECTANGLE. THERE IS ONE DOT TO THE LEFT OF THE LETTERS "DC", AND ONE DOT TO THE RIGHT OF THE LETTERS "DC".
 FOR BAR AND RESTAURANT SERVICES (U.S. CLS. 100 AND 101).
 KEVIN CORWIN, EXAMINING ATTORNEY

SN 85-445,655. LEGEND BREWING CO., RICHMOND, VA. FILED 10-12-2011.

Legend Brewing Co.

THE MARK CONSISTS OF STANDARD CHARACTERS WITHOUT CLAIM TO ANY PARTICULAR FONT, STYLE, SIZE, OR COLOR.
 OWNER OF U.S. REG. NOS. 2,183,228, 2,197,635 AND OTHERS.
 NO CLAIM IS MADE TO THE EXCLUSIVE RIGHT TO USE "BREWING CO.", APART FROM THE MARK AS SHOWN.
 FOR RESTAURANT AND BAR SERVICES (U.S. CLS. 100 AND 101).
 FIRST USE 1-0-1994; IN COMMERCE 1-0-1994.
 JOHN WILKE, EXAMINING ATTORNEY

SN 85-445,511. BOXERS NYC LLC, NEW YORK, NY. FILED 10-12-2011.



NO CLAIM IS MADE TO THE EXCLUSIVE RIGHT TO USE "NYC", APART FROM THE MARK AS SHOWN.
 THE MARK CONSISTS OF THE WORD "BOXERS" IN STYLIZED LETTERING, ABOVE WHICH IS AN IMAGE OF A DOG, AND BELOW WHICH ARE THE LETTERS "NYC" IN STYLIZED LETTERING LOCATED WITHIN A RECTANGLE. THERE IS ONE DOT TO THE LEFT OF THE LETTERS "NYC", AND ONE DOT TO THE RIGHT OF THE LETTERS "NYC".
 FOR BAR AND RESTAURANT SERVICES (U.S. CLS. 100 AND 101).
 FIRST USE 4-28-2010; IN COMMERCE 4-28-2010.
 KEVIN CORWIN, EXAMINING ATTORNEY

SN 85-445,822. TWIN CITY CHRISTIAN HOMES, INC., RICHFIELD, MN. FILED 10-12-2011.

AVINITY

THE MARK CONSISTS OF STANDARD CHARACTERS WITHOUT CLAIM TO ANY PARTICULAR FONT, STYLE, SIZE, OR COLOR.
 FOR CHARITABLE SERVICES, NAMELY, PROVIDING HOUSING AND ASSISTED LIVING FACILITIES TO SENIOR CITIZENS (U.S. CLS. 100 AND 101).
 AMY KELLY, EXAMINING ATTORNEY

CLASS 43—(Continued).

SN 85-445,883. N-M VENTURES, LLC, LAS VEGAS, NV.
FILED 10-12-2011.

GBDC

THE MARK CONSISTS OF STANDARD CHARACTERS WITHOUT CLAIM TO ANY PARTICULAR FONT, STYLE, SIZE, OR COLOR.

FOR COCKTAIL LOUNGE SERVICES; PROVIDING SOCIAL MEETING, BANQUET AND SOCIAL FUNCTION FACILITIES; RESTAURANT AND BAR SERVICES (U.S. CLS. 100 AND 101).

FIRST USE 10-22-2011; IN COMMERCE 10-22-2011.
BRENDAN MCCAULEY, EXAMINING ATTORNEY

SN 85-445,919. N-M VENTURES, LLC, LAS VEGAS, NV.
FILED 10-12-2011.



FOR COCKTAIL LOUNGE SERVICES; PROVIDING SOCIAL MEETING, BANQUET AND SOCIAL FUNCTION FACILITIES; RESTAURANT AND BAR SERVICES (U.S. CLS. 100 AND 101).

FIRST USE 10-22-2011; IN COMMERCE 10-22-2011.
BRENDAN MCCAULEY, EXAMINING ATTORNEY

SN 85-446,113. DAVIDSON, DEMETRIA A., FORT BELVOIR,
VA. FILED 10-12-2011.

DEE'S KIDDY KORNER CHILD CARE

THE MARK CONSISTS OF STANDARD CHARACTERS WITHOUT CLAIM TO ANY PARTICULAR FONT, STYLE, SIZE, OR COLOR.

NO CLAIM IS MADE TO THE EXCLUSIVE RIGHT TO USE "KIDDY" OR "CHILD CARE", APART FROM THE MARK AS SHOWN.

FOR CHILD CARE SERVICES (U.S. CLS. 100 AND 101).
HANNO RITTNER, EXAMINING ATTORNEY

CLASS 43—(Continued).

SN 85-446,169. SUSHI TOKYO CI INC., BROOKLYN, NY.
FILED 10-13-2011.

SUSHI TOKYO

THE MARK CONSISTS OF STANDARD CHARACTERS WITHOUT CLAIM TO ANY PARTICULAR FONT, STYLE, SIZE, OR COLOR.

NO CLAIM IS MADE TO THE EXCLUSIVE RIGHT TO USE "SUSHI", APART FROM THE MARK AS SHOWN.
FOR RESTAURANT SERVICES (U.S. CLS. 100 AND 101).

FIRST USE 0-0-2008; IN COMMERCE 0-0-2008.
DEBORAH LOBO, EXAMINING ATTORNEY

SN 85-446,508. MCCUTCHEN, MARCIA ALICE, SUGAR
LAND, TX. FILED 10-13-2011.



NO CLAIM IS MADE TO THE EXCLUSIVE RIGHT TO USE "CHEF", APART FROM THE MARK AS SHOWN.

THE STIPPLING IS FOR SHADING PURPOSES ONLY.
THE MARK CONSISTS OF THE STYLIZED TEXT OF "CHEF FOR YOU" WITH TWO CARROTS GOING THROUGH THE "C" IN "CHEF". ON THE BACKGROUND THERE IS A PLATE AND A SET OF UTENSILS.

FOR CATERING SERVICES (U.S. CLS. 100 AND 101).
FIRST USE 1-2-2001; IN COMMERCE 1-2-2001.
TARAH HARDY, EXAMINING ATTORNEY

SN 85-446,843. INDIGENOUS, LLC, SARASOTA, FL. FILED
10-13-2011.

INDIGENOUS

THE MARK CONSISTS OF STANDARD CHARACTERS WITHOUT CLAIM TO ANY PARTICULAR FONT, STYLE, SIZE, OR COLOR.

FOR RESTAURANT SERVICES (U.S. CLS. 100 AND 101).

FIRST USE 9-7-2011; IN COMMERCE 9-7-2011.
GEORGE LORENZO, EXAMINING ATTORNEY

CLASS 43—(Continued).

SN 85-446,866. THE QUINTESSENCE CORPORATION, DBA
TEXADELPHIA, RICHARDSON, TX. FILED 10-13-2011.

Texadelphia Social Grill

THE MARK CONSISTS OF STANDARD CHARACTERS
WITHOUT CLAIM TO ANY PARTICULAR FONT, STYLE,
SIZE, OR COLOR.

OWNER OF U.S. REG. NO. 2,092,102.

NO CLAIM IS MADE TO THE EXCLUSIVE RIGHT TO
USE "GRILL", APART FROM THE MARK AS SHOWN.

FOR RESTAURANT SERVICES, NAMELY, PROVIDING
OF FOOD AND BEVERAGES FOR CONSUMPTION
ON AND OFF THE PREMISES (U.S. CLS. 100 AND 101).

KIMBERLY PERRY, EXAMINING ATTORNEY

SN 85-447,090. GIUSEPPE VITALE, WEST HOLLYWOOD,
CA. FILED 10-13-2011.

OWNER OF U.S. REG. NO. 3,508,216.

NO CLAIM IS MADE TO THE EXCLUSIVE RIGHT TO
USE "PIZZA", APART FROM THE MARK AS SHOWN.

THE COLOR(S) RED IS/ARE CLAIMED AS A FEATURE
OF THE MARK.

THE MARK CONSISTS OF THE STYLIZED TEXT "JOE'S
PIZZA" IN RED.

FOR RESTAURANT SERVICES FEATURING PIZZA
(U.S. CLS. 100 AND 101).

FIRST USE 10-13-2011; IN COMMERCE 10-13-2011.

BENJAMIN OKEKE, EXAMINING ATTORNEY

SN 85-447,489. JET CITY FOODS LLC, MERCER ISLAND,
WA. FILED 10-14-2011.

SMOKIN TACOS

THE MARK CONSISTS OF STANDARD CHARACTERS
WITHOUT CLAIM TO ANY PARTICULAR FONT, STYLE,
SIZE, OR COLOR.

NO CLAIM IS MADE TO THE EXCLUSIVE RIGHT TO
USE "TACOS", APART FROM THE MARK AS SHOWN.

FOR RESTAURANT SERVICES, NAMELY, PROVIDING
OF FOOD AND BEVERAGES FOR CONSUMPTION
ON AND OFF THE PREMISES (U.S. CLS. 100 AND 101).

KATHRYN COWARD, EXAMINING ATTORNEY

CLASS 43—(Continued).

SN 85-447,701. DIANE PERAZA, MUTTONTOWN, NY.
FILED 10-14-2011.

PAW-FURD FETCH

THE MARK CONSISTS OF STANDARD CHARACTERS
WITHOUT CLAIM TO ANY PARTICULAR FONT, STYLE,
SIZE, OR COLOR.

OWNER OF U.S. REG. NO. 3,551,131.

FOR PROVIDING PET FOOD AND BEVERAGES VIA
A MOBILE TRUCK (U.S. CLS. 100 AND 101).

JEAN IM, EXAMINING ATTORNEY

SN 85-447,933. ACCOR NORTH AMERICA, INC., CARROLL-
TON, TX. FILED 10-14-2011.

OWNER OF U.S. REG. NO. 3,077,166.

NO CLAIM IS MADE TO THE EXCLUSIVE RIGHT TO
USE "CORPORATE", APART FROM THE MARK AS
SHOWN.

THE COLOR(S) BLUE, WHITE, RED AND GRAY IS/ARE
CLAIMED AS A FEATURE OF THE MARK.

THE MARK CONSISTS OF THE PHRASE "CORPORATE
PLUS" IN WHITE WITH THE FIRST WORD SET AGAINST
A BLUE BACKGROUND AND THE SECOND A RED
BACKGROUND FOLLOWED BY "@" IN GRAY AND THE
NUMBER "6" IN BLUE.

FOR HOTEL AND MOTEL SERVICES; HOTEL AND
MOTEL SERVICES FOR PREFERRED CUSTOMERS
(U.S. CLS. 100 AND 101).

FIRST USE 7-27-2011; IN COMMERCE 7-27-2011.

RAUL CORDOVA, EXAMINING ATTORNEY

CLASS 43—(Continued).

SN 85-448,122. ELIAS, NECOLE, DALLAS, TX. FILED 10-14-2011.



NO CLAIM IS MADE TO THE EXCLUSIVE RIGHT TO USE "BARTENDING", APART FROM THE MARK AS SHOWN.

THE MARK CONSISTS OF THE STYLIZED WORDS "BARTENDING DIVAS". AN IMAGE OF A MARTINI GLASS WITH A WOMAN'S LEG AS THE STEM WITH HIGH HEEL SHOE AS THE BASE ABOVE THE TEXT.

FOR SERVING FOOD AND DRINKS, NAMELY, PROVIDING FEMALE WAIT STAFF AND BARTENDERS FOR SOCIAL ENTERTAINMENT AND SPECIAL EVENTS (U.S. CLS. 100 AND 101).

FIRST USE 4-1-2009; IN COMMERCE 4-1-2009.
B. PARADEWELAI, EXAMINING ATTORNEY

SN 85-448,162. CACHE CACHE, LTD., ASPEN, CO. FILED 10-14-2011.

CACHE CACHE

THE MARK CONSISTS OF STANDARD CHARACTERS WITHOUT CLAIM TO ANY PARTICULAR FONT, STYLE, SIZE, OR COLOR.

THE ENGLISH TRANSLATION OF CACHE CACHE IN THE MARK IS "HIDE N SEEK".

FOR BAR SERVICES; RESTAURANT SERVICES; SERVING FOOD AND DRINKS (U.S. CLS. 100 AND 101).

FIRST USE 10-17-1987; IN COMMERCE 10-17-1987.
SHAUNIA CARLYLE, EXAMINING ATTORNEY

CLASS 43—(Continued).

SN 85-448,414. BROWN, DAVID ALAN, DUBLIN, OH. FILED 10-16-2011.

SUBTEMBER

THE MARK CONSISTS OF STANDARD CHARACTERS WITHOUT CLAIM TO ANY PARTICULAR FONT, STYLE, SIZE, OR COLOR.

FOR FAST-FOOD RESTAURANT SERVICES; MOBILE RESTAURANT SERVICES; RESTAURANT SERVICES; RESTAURANT SERVICES FEATURING SUB SANDWICHES; RESTAURANT SERVICES, INCLUDING SIT-DOWN SERVICE OF FOOD AND TAKE-OUT RESTAURANT SERVICES; RESTAURANT SERVICES, NAMELY, PROVIDING OF FOOD AND BEVERAGES FOR CONSUMPTION ON AND OFF THE PREMISES; TAKE-OUT RESTAURANT SERVICES (U.S. CLS. 100 AND 101).

DOMINIC FATHY, EXAMINING ATTORNEY

SN 85-448,449. PATEL, KAMLESH, SAN DIEGO, CA. FILED 10-16-2011.



NO CLAIM IS MADE TO THE EXCLUSIVE RIGHT TO USE "STIR FRY", APART FROM THE MARK AS SHOWN.

THE COLOR(S) YELLOW, RED, GREEN, BLACK, WHITE AND GREY IS/ARE CLAIMED AS A FEATURE OF THE MARK.

THE MARK CONSISTS OF A BLACK SQUARE BORDER CONTAINING THE WORDS "STIR" IN YELLOW, "FRY" IN RED, AND "BOWL" IN GREEN, OUTLINED IN BLACK AND THEN SUPERIMPOSED IN A WHITE OUTLINE THEN ALL WORDS ARE ENCAPSULATED IN A THICKER BLACK OUTLINE. THE WORDS ARE STACKED ON TOP OF EACH OTHER WITH A SEMI-CIRCULAR BASE AT THE BOTTOM HOLDING THE WORDS. THE BASE INCLUDES A GREY SHADOW. TWO BLACK CHOPSTICKS PROTRUDE FROM THE LETTER "B" AND EXTEND OUT PAST THE SQUARE BORDER. THE BASE OF THE SQUARE CONTAINS A ROUNDED OBLONG SHAPE IN BLACK CONTAINING THE WORDS "CREATE YOUR OWN EXPERIENCE!" IN WHITE LETTERING.

FOR FAST-FOOD RESTAURANT SERVICES; RESTAURANT AND CATERING SERVICES; RESTAURANT SERVICES; RESTAURANT SERVICES, INCLUDING SIT-DOWN SERVICE OF FOOD AND TAKE-OUT RESTAURANT SERVICES; RESTAURANT SERVICES, NAMELY, PROVIDING OF FOOD AND BEVERAGES FOR CONSUMPTION ON AND OFF THE PREMISES; SELF-SERVICE RESTAURANTS (U.S. CLS. 100 AND 101).

GEOFFREY FOSDICK, EXAMINING ATTORNEY

CLASS 43—(Continued).

SN 85-448,810. THENA FOOTE, JOHNSON, NY. FILED 10-17-2011.



NO CLAIM IS MADE TO THE EXCLUSIVE RIGHT TO USE "PROGRESSIVE STREET FOOD", APART FROM THE MARK AS SHOWN.

THE MARK CONSISTS OF THE WORDS "NOMAD PROGRESSIVE STREET FOOD" AND THE DESIGN OF A STYLIZED DEPICTION OF A CHEF HIKING, WEARING A CHEF'S HAT AND A BACKPACK, AND USING A WALKING STICK SHAPED LIKE A CHOP STICK.

FOR MOBILE CAFE SERVICES FOR PROVIDING FRESH, LOCAL, PROPERLY PROPORTIONED, HEALTHY FOOD AND DRINK (U.S. CLS. 100 AND 101).
CARYN GLASSER, EXAMINING ATTORNEY

SN 85-448,833. NAM PHAMTRAN, GARDEN GROVE, CA. FILED 10-17-2011.

SWSH SHABU SHABU

THE MARK CONSISTS OF STANDARD CHARACTERS WITHOUT CLAIM TO ANY PARTICULAR FONT, STYLE, SIZE, OR COLOR.

NO CLAIM IS MADE TO THE EXCLUSIVE RIGHT TO USE "SHABU SHABU", APART FROM THE MARK AS SHOWN.

FOR RESTAURANT SERVICES (U.S. CLS. 100 AND 101).

FIRST USE 7-1-2011; IN COMMERCE 7-1-2011.
TIMOTHY FINNEGAN, EXAMINING ATTORNEY

SN 85-449,149. ASHA'S RESTAURANTS INTERNATIONAL LIMITED, DUBAI, UNITED ARAB EMIR., FILED 10-17-2011.

ASHA'S

THE MARK CONSISTS OF STANDARD CHARACTERS WITHOUT CLAIM TO ANY PARTICULAR FONT, STYLE, SIZE, OR COLOR.

FOR RESTAURANT SERVICES, INCLUDING BUT NOT LIMITED TO, SELF-SERVICE RESTAURANT SERVICES; RESTAURANTS FEATURING HOME DELIVERY; CATERING SERVICES; AND FOOD PREPARATION (U.S. CLS. 100 AND 101).

KATHERINE CONNOLLY, EXAMINING ATTORNEY

CLASS 43—(Continued).

SN 85-449,195. HAJDIN RRACI, CROSS RIVER, NY. AND KUJTIM RRACI, CROSS RIVER, NY. FILED 10-17-2011.

Rraci's

THE MARK CONSISTS OF STANDARD CHARACTERS WITHOUT CLAIM TO ANY PARTICULAR FONT, STYLE, SIZE, OR COLOR.

SEC. 2(F).
FOR FAST-FOOD RESTAURANT SERVICES; PIZZA PARLORS; RESTAURANT AND CAFE SERVICES; RESTAURANT SERVICES; RESTAURANT SERVICES FEATURING ITALIAN CUISINE; RESTAURANT SERVICES, INCLUDING SIT-DOWN SERVICE OF FOOD AND TAKE-OUT RESTAURANT SERVICES; RESTAURANT SERVICES, NAMELY, PROVIDING OF FOOD AND BEVERAGES FOR CONSUMPTION ON AND OFF THE PREMISES; TAKE-OUT RESTAURANT SERVICES (U.S. CLS. 100 AND 101).

FIRST USE 4-1-2002; IN COMMERCE 4-1-2002.
KELLEY WELLS, EXAMINING ATTORNEY

SN 85-449,202. DAVID MAGROGAN GROUP, LLC, WEST CHESTER, PA. FILED 10-17-2011.



NO CLAIM IS MADE TO THE EXCLUSIVE RIGHT TO USE "SEASONAL GRILL & WINE BAR", APART FROM THE MARK AS SHOWN.

THE MARK CONSISTS OF THE TERMINOLOGY "HARVEST SEASONAL GRILL & WINE BAR" ON A RECTANGULAR CARRIER FEATURING THREE GRAIN STALKS. FOR RESTAURANT SERVICES; WINE BARS (U.S. CLS. 100 AND 101).

FIRST USE 4-1-2010; IN COMMERCE 10-24-2010.
HAI-LY LAM, EXAMINING ATTORNEY

CLASS 43—(Continued).

SN 85-449,256. RUBIN, STUART, COVINA, CA. FILED 10-17-2011.

PUPS & PINTS

THE MARK CONSISTS OF STANDARD CHARACTERS WITHOUT CLAIM TO ANY PARTICULAR FONT, STYLE, SIZE, OR COLOR.

NO CLAIM IS MADE TO THE EXCLUSIVE RIGHT TO USE "PINTS", APART FROM THE MARK AS SHOWN. FOR RESTAURANT SERVICES (U.S. CLS. 100 AND 101).

LINDA LAVACHE, EXAMINING ATTORNEY

SN 85-449,420. WECARE A SENIOR PLACEMENT SERVICE, TRAVERSE CITY, MI. AND OHEARN, JOHN, TRAVERSE CITY, MI. AND OHEARN, JEANNE, TRAVERSE CITY, MI. FILED 10-18-2011.



THE COLOR(S) LIGHT GREEN, WHITE AND DARK GREEN IS/ARE CLAIMED AS A FEATURE OF THE MARK.

THE MARK CONSISTS OF A UNIQUE BOX SEEMS AS A TAG IN DARK GREEN COLOR WHEREIN THERE IS AN IMAGE OF A TREE IN WHITE COLOR ENCLOSED IN CIRCLE FILLED WITH LIGHT GREEN COLOR HAVING A WHITE BORDER, AT THE RIGHT OF THIS IMAGE THE WORDS "WE" IN LIGHT GREEN COLOR AND THE WORD "CARE" IN WHITE COLOR IS WRITTEN ONE UNDER ANOTHER AS SHOWN IN THE MARK.

FOR PROVIDING ASSISTANCE TO SENIOR CITIZENS SEEKING TO DETERMINE ASSISTED LIVING FACILITIES APPROPRIATE FOR THEIR NEEDS (U.S. CLS. 100 AND 101).

FIRST USE 9-5-2011; IN COMMERCE 9-20-2011.
SUSAN RICHARDS, EXAMINING ATTORNEY

SN 85-449,655. MIRCHI INC, PRINCETON JUNCTION, NJ. FILED 10-18-2011.



NO CLAIM IS MADE TO THE EXCLUSIVE RIGHT TO USE "MIRCHI", APART FROM THE MARK AS SHOWN.

THE MARK CONSISTS OF THE WORD "MIRCHI" WITH BOTH THE LETTER "I" S DESIGNED LIKE A CHILI.

THE ENGLISH TRANSLATION OF "MIRCHI" IN THE MARK IS "CHILI".

FOR RESTAURANT SERVICES (U.S. CLS. 100 AND 101).

FIRST USE 5-15-2010; IN COMMERCE 5-15-2010.
HANNO RITTNER, EXAMINING ATTORNEY

CLASS 43—(Continued).

SN 85-449,687. TWO FISHERMAN, INC., SANTA ANA, CA. FILED 10-18-2011.



NO CLAIM IS MADE TO THE EXCLUSIVE RIGHT TO USE "GRILL & ROLLS", APART FROM THE MARK AS SHOWN.

THE COLOR(S) BLUE, LIGHT BLUE, YELLOW AND RED IS/ARE CLAIMED AS A FEATURE OF THE MARK.

THE MARK CONSISTS OF A STYLIZED FISH IN THE SHAPE OF A 2. THE BODY OF THE FISH IS LIGHT BLUE AND THE FINS AND TAIL ARE BLUE. THERE IS A YELLOW OUTLINE ON THE LEFT OF THE FISH. THE BLUE TAIL EXTENDS TO THE RIGHT OF THE LOGO IN A ZIG ZAG LINE. TO THE RIGHT OF THE FISH IS THE YELLOW STYLIZED WORD "FISHERMEN", OUTLINED IN BLUE. BELOW THE ZIG ZAG LINE ARE THE RED WORDS "GRILL & ROLLS".

FOR RESTAURANT SERVICES (U.S. CLS. 100 AND 101).

FIRST USE 9-24-2011; IN COMMERCE 9-24-2011.
LINDSEY RUBIN, EXAMINING ATTORNEY

SN 85-449,804. LYNDA ANNISON, DBA NURTURING RUBY GEMS CHILD CARE, SANTA CLARA, CA. FILED 10-18-2011.

NURTURING RUBY GEMS CHILD CARE

THE MARK CONSISTS OF STANDARD CHARACTERS WITHOUT CLAIM TO ANY PARTICULAR FONT, STYLE, SIZE, OR COLOR.

NO CLAIM IS MADE TO THE EXCLUSIVE RIGHT TO USE "CHILD CARE", APART FROM THE MARK AS SHOWN.

FOR CHILD CARE SERVICES (U.S. CLS. 100 AND 101).
FIRST USE 9-21-2011; IN COMMERCE 10-17-2011.

MICHELE SWAIN, EXAMINING ATTORNEY

SN 85-450,048. DENIHAN OWNERSHIP COMPANY, LLC, NEW YORK, NY. FILED 10-18-2011.

TLC TENDER LOVING COMFORT

THE MARK CONSISTS OF STANDARD CHARACTERS WITHOUT CLAIM TO ANY PARTICULAR FONT, STYLE, SIZE, OR COLOR.

FOR HOTEL SERVICES (U.S. CLS. 100 AND 101).
FIRST USE 10-17-2011; IN COMMERCE 10-17-2011.

NAKWAMA ANKRAH, EXAMINING ATTORNEY

CLASS 43—(Continued).

SN 85-450,299. COOL BEANS, INC., HOUSTON, TX. FILED 10-18-2011.

Mama Tran's Trailer

THE MARK CONSISTS OF STANDARD CHARACTERS WITHOUT CLAIM TO ANY PARTICULAR FONT, STYLE, SIZE, OR COLOR.

FOR RESTAURANT AND CATERING SERVICES (U.S. CLS. 100 AND 101).

JILL C. ALT, EXAMINING ATTORNEY

SN 85-450,490. SG GROUP INC., HONOLULU, HI. FILED 10-18-2011.

PHO FACTORY

THE MARK CONSISTS OF STANDARD CHARACTERS WITHOUT CLAIM TO ANY PARTICULAR FONT, STYLE, SIZE, OR COLOR.

NO CLAIM IS MADE TO THE EXCLUSIVE RIGHT TO USE "PHO", APART FROM THE MARK AS SHOWN.

THE ENGLISH TRANSLATION OF "PHO" IN THE MARK IS "NOODLE SOUP".

FOR RESTAURANT SERVICES; RESTAURANT SERVICES FEATURING VIETNAMESE FOOD; RESTAURANT SERVICES, INCLUDING SIT-DOWN SERVICE OF FOOD AND TAKE-OUT RESTAURANT SERVICES (U.S. CLS. 100 AND 101).

LEIGH CAROLINE CASE, EXAMINING ATTORNEY

SN 85-450,726. PREMENSIS LLC, WILMINGTON, DE. FILED 10-19-2011.



The logo for "Miso Yummy" features the word "Miso" in a black, cursive font, followed by a stylized green circle with a red mouth and a green face, and the word "Yummy" in a black, cursive font.

THE COLOR(S) BLACK, RED, GREEN IS/ARE CLAIMED AS A FEATURE OF THE MARK.

THE MARK CONSISTS OF THE WORDING "MISO YUMMY" IN BLACK. THE LETTER "O" IN "MISO" HAS A GREEN FACE DRAWN WITH A RED MOUTH. THE DOT IN THE LETTER "I" IS IN GREEN.

FOR RESTAURANT AND CAFE SERVICES (U.S. CLS. 100 AND 101).

JOHN HWANG, EXAMINING ATTORNEY

CLASS 43—(Continued).

SN 85-451,440. FURANO, DAVID, EL SEGUNDO, CA. FILED 10-19-2011.

Balls & Brews

THE MARK CONSISTS OF STANDARD CHARACTERS WITHOUT CLAIM TO ANY PARTICULAR FONT, STYLE, SIZE, OR COLOR.

NO CLAIM IS MADE TO THE EXCLUSIVE RIGHT TO USE "BREWS", APART FROM THE MARK AS SHOWN.

FOR BAR SERVICES; RESTAURANT SERVICES (U.S. CLS. 100 AND 101).

FIRST USE 7-25-2011; IN COMMERCE 7-25-2011.
GIANCARLO CASTRO, EXAMINING ATTORNEY

SN 85-451,456. GALARDI GROUP, INC., IRVINE, CA. FILED 10-19-2011.

TWO MADRES

THE MARK CONSISTS OF STANDARD CHARACTERS WITHOUT CLAIM TO ANY PARTICULAR FONT, STYLE, SIZE, OR COLOR.

THE ENGLISH TRANSLATION OF "MADRES" IN THE MARK IS "MOTHERS".

FOR RESTAURANT SERVICES (U.S. CLS. 100 AND 101).

ANDREA HACK, EXAMINING ATTORNEY

SN 85-451,489. ERIC ONG, LOS ANGELES, CA. FILED 10-19-2011.

Humble Potato

THE MARK CONSISTS OF STANDARD CHARACTERS WITHOUT CLAIM TO ANY PARTICULAR FONT, STYLE, SIZE, OR COLOR.

FOR RESTAURANT SERVICES, INCLUDING SIT-DOWN SERVICE OF FOOD AND TAKE-OUT RESTAURANT SERVICES (U.S. CLS. 100 AND 101).

THEODORE MCBRIDE, EXAMINING ATTORNEY

CLASS 43—(Continued).

SN 85-451,496. ERIC ONG, LOS ANGELES, CA. FILED 10-19-2011.

Japanese With Attitude

THE MARK CONSISTS OF STANDARD CHARACTERS WITHOUT CLAIM TO ANY PARTICULAR FONT, STYLE, SIZE, OR COLOR.

NO CLAIM IS MADE TO THE EXCLUSIVE RIGHT TO USE "JAPANESE", APART FROM THE MARK AS SHOWN.

FOR RESTAURANT SERVICES, INCLUDING SIT-DOWN SERVICE OF FOOD AND TAKE-OUT RESTAURANT SERVICES (U.S. CLS. 100 AND 101).

THEODORE MCBRIDE, EXAMINING ATTORNEY

SN 85-451,530. FIFTH STREET GAMING, LLC, LAS VEGAS, NV. FILED 10-19-2011.

DOWNTOWN GRAND

THE MARK CONSISTS OF STANDARD CHARACTERS WITHOUT CLAIM TO ANY PARTICULAR FONT, STYLE, SIZE, OR COLOR.

FOR ARENA SERVICES, NAMELY, PROVIDING FACILITIES FOR SPORTS, CONCERTS, CONVENTIONS AND EXHIBITIONS; BAR SERVICES; COCKTAIL LOUNGE SERVICES; PROVIDING BANQUET AND SOCIAL FUNCTION FACILITIES FOR SPECIAL OCCASIONS; PROVISION OF CONFERENCE, EXHIBITION AND MEETING FACILITIES; PROVISION OF FACILITIES FOR CONVENTIONS; RESTAURANT SERVICES (U.S. CLS. 100 AND 101).

DAVID HOFFMAN, EXAMINING ATTORNEY

SN 85-460,665. MOTHER CLUCKERS GRILL LLC, FALLSTON, MD. FILED 10-31-2011.

THE CHICKEN ON THE ROOF GRILL

THE MARK CONSISTS OF STANDARD CHARACTERS WITHOUT CLAIM TO ANY PARTICULAR FONT, STYLE, SIZE, OR COLOR.

NO CLAIM IS MADE TO THE EXCLUSIVE RIGHT TO USE "GRILL", APART FROM THE MARK AS SHOWN.

FOR RESTAURANT SERVICES; TAKE-OUT RESTAURANT SERVICES; CARRYOUT RESTAURANT SERVICES (U.S. CLS. 100 AND 101).

ALICIA COLLINS, EXAMINING ATTORNEY

CLASS 43—(Continued).

SN 85-460,749. MOTHER CLUCKERS GRILL LLC, FALLSTON, MD. FILED 10-31-2011.



NO CLAIM IS MADE TO THE EXCLUSIVE RIGHT TO USE "GRILL", APART FROM THE MARK AS SHOWN.

THE COLOR(S) YELLOW, BLACK, RED, BLUE, BROWN AND WHITE IS/ARE CLAIMED AS A FEATURE OF THE MARK.

THE MARK CONSISTS OF THE LITERAL ELEMENTS "THE CHICKEN ON THE ROOF GRILL" WHEREIN THERE IS AN IMAGE OF A YELLOW RECTANGLE WITH WORDS "THE CHICKEN" WRITTEN IN YELLOW WITH BLACK OUTLINE AND THE OTHER WORDS "ON THE ROOF GRILL" WRITTEN IN RED WITH BLACK OUTLINE AND TO THE RIGHT OF WHICH THERE IS AN IMAGE OF A COCK IN RED, WHITE, YELLOW, BROWN AND BLUE ABOVE THE LETTER "F" IN THE WORD "ROOF" AND LETTERS "GR" IN THE WORD "GRILL".

FOR RESTAURANT SERVICES; TAKE-OUT RESTAURANT SERVICES; CARRYOUT RESTAURANT SERVICES (U.S. CLS. 100 AND 101).

ALICIA COLLINS, EXAMINING ATTORNEY

SN 85-467,951. HLT INTERNATIONAL IP LLC, MCLEAN, VA. FILED 11-9-2011.

EMBASSY SUITES BY HILTON

THE MARK CONSISTS OF STANDARD CHARACTERS WITHOUT CLAIM TO ANY PARTICULAR FONT, STYLE, SIZE, OR COLOR.

OWNER OF U.S. REG. NOS. 788,856, 2,478,190 AND OTHERS.

NO CLAIM IS MADE TO THE EXCLUSIVE RIGHT TO USE "SUITES", APART FROM THE MARK AS SHOWN.

FOR HOTEL SERVICES; RESTAURANT, CATERING, BAR AND COCKTAIL LOUNGE SERVICES; RESORT LODGING SERVICES; PROVISION OF GENERAL PURPOSE FACILITIES FOR MEETINGS, CONFERENCES AND EXHIBITIONS; PROVISION OF BANQUETING AND SOCIAL FUNCTION FACILITIES FOR SPECIAL OCCASIONS; AND RESERVATION SERVICE FOR HOTEL ACCOMMODATIONS FOR OTHERS (U.S. CLS. 100 AND 101).

ALLISON HOLTZ, EXAMINING ATTORNEY

CLASS 43—(Continued).

SN 85-468,032. HLT INTERNATIONAL IP LLC, MCLEAN, VA. FILED 11-9-2011.



OWNER OF U.S. REG. NOS. 788,856, 2,478,190 AND OTHERS.

NO CLAIM IS MADE TO THE EXCLUSIVE RIGHT TO USE "SUITES", APART FROM THE MARK AS SHOWN.

THE MARK CONSISTS OF STYLIZED "E" WITH THE CENTER LINE COMPONENT COMPRISED OF A LEAF DESIGN AND THE WORDS "EMBASSY SUITES BY HILTON".

FOR HOTEL SERVICES; RESTAURANT, CATERING, BAR AND COCKTAIL LOUNGE SERVICES; RESORT LODGING SERVICES; PROVISION OF GENERAL PURPOSE FACILITIES FOR MEETINGS, CONFERENCES AND EXHIBITIONS; PROVISION OF BANQUETING AND SOCIAL FUNCTION FACILITIES FOR SPECIAL OCCASIONS; AND RESERVATION SERVICE FOR HOTEL ACCOMMODATIONS FOR OTHERS (U.S. CLS. 100 AND 101).

ALLISON HOLTZ, EXAMINING ATTORNEY

CLASS 43—(Continued).

SN 85-483,443. LORITO, TIMOTHY, HOLTSVILLE, NY. FILED 11-30-2011.



THE MARK CONSISTS OF A DIAMOND SHAPE DESIGN WITH THE STYLIZED WORD "CANSTRUCTION" INSIDE. FOR BAR SERVICES; RESTAURANT SERVICES (U.S. CLS. 100 AND 101).

FIRST USE 8-1-2010; IN COMMERCE 8-1-2011.

LINDA ORNDORFF, EXAMINING ATTORNEY

SN 85-481,369. PAMPLONA TAPAS BAR AND RESTAURANT, LLC, LAFAYETTE, LA. FILED 11-28-2011.

Pamplona

THE MARK CONSISTS OF STANDARD CHARACTERS WITHOUT CLAIM TO ANY PARTICULAR FONT, STYLE, SIZE, OR COLOR.

FOR RESTAURANT SERVICES (U.S. CLS. 100 AND 101).

FIRST USE 10-1-2007; IN COMMERCE 10-1-2007. WILLIAM ROSSMAN, EXAMINING ATTORNEY



THE MARK CONSISTS OF THE LETTER "I" ABOVE A HEART SYMBOL, AND 2 BEER CAN TOPS BELOW THE HEART SYMBOL.

FOR RESTAURANT AND BAR SERVICES (U.S. CLS. 100 AND 101).

FIRST USE 8-1-2011; IN COMMERCE 8-1-2011. LINDA ORNDORFF, EXAMINING ATTORNEY

CLASS 43—(Continued).

SN 85-500,983. CULTURE CLUB FROZEN YOGURT LLC, LITTLE SILVER, NJ. FILED 12-21-2011.

DA WORLD'S CHILLEST FROZEN
YOGURT

THE MARK CONSISTS OF STANDARD CHARACTERS WITHOUT CLAIM TO ANY PARTICULAR FONT, STYLE, SIZE, OR COLOR.

NO CLAIM IS MADE TO THE EXCLUSIVE RIGHT TO USE "FROZEN YOGURT", APART FROM THE MARK AS SHOWN.

FOR RESTAURANT SERVICES OFFERING PRIMARILY FROZEN YOGURT (U.S. CLS. 100 AND 101).
NICHOLAS ALTREE, EXAMINING ATTORNEY

SN 85-513,156. HLT INTERNATIONAL IP LLC, MCLEAN, VA. FILED 1-10-2012.



OWNER OF U.S. REG. NO. 3,092,607.
NO CLAIM IS MADE TO THE EXCLUSIVE RIGHT TO USE "SUITE" AND "GUARANTEE", APART FROM THE MARK AS SHOWN.

THE MARK CONSISTS OF A BOX CONTAINING A DUCK DESIGN DIVIDED BY A HORIZONTAL LINE THEN THE WORDS "SUITE ASSURANCE" ABOVE "GUARANTEE".

FOR HOTEL SERVICES; RESTAURANT, CATERING, BAR AND COCKTAIL LOUNGE SERVICES; RESORT LODGING SERVICES; PROVISION OF GENERAL PURPOSE FACILITIES FOR MEETINGS, CONFERENCES AND EXHIBITIONS; PROVISION OF BANQUETING AND SOCIAL FUNCTION FACILITIES FOR SPECIAL OCCASIONS; AND RESERVATION SERVICE FOR HOTEL ACCOMMODATIONS FOR OTHERS; ALL INCLUDED IN CLASS 43 (U.S. CLS. 100 AND 101).
ALLISON HOLTZ, EXAMINING ATTORNEY

SN 85-513,265. N-M VENTURES, LLC, LAS VEGAS, NV. FILED 1-10-2012.

FANCY SAUCE

THE MARK CONSISTS OF STANDARD CHARACTERS WITHOUT CLAIM TO ANY PARTICULAR FONT, STYLE, SIZE, OR COLOR.

FOR BAR SERVICES; COCKTAIL LOUNGE SERVICES; PROVIDING BANQUET AND SOCIAL FUNCTION FACILITIES FOR SPECIAL OCCASIONS; RESTAURANT SERVICES (U.S. CLS. 100 AND 101).
BRENDAN MCCAULEY, EXAMINING ATTORNEY

CLASS 43—(Continued).

SN 85-514,800. HLT INTERNATIONAL IP LLC, MCLEAN, VA. FILED 1-12-2012.



OWNER OF U.S. REG. NOS. 788,856, 2,478,190 AND OTHERS.

NO CLAIM IS MADE TO THE EXCLUSIVE RIGHT TO USE "SUITES", APART FROM THE MARK AS SHOWN.

THE MARK CONSISTS OF THE WORD "HOMEWOOD" WITH A DUCK DESIGN UNDERNEATH SPLITTING TWO LINES WITH THE WORDS "SUITES" AND "BY HILTON".

FOR HOTEL SERVICES; RESTAURANT, CATERING, BAR AND COCKTAIL LOUNGE SERVICES; RESORT LODGING SERVICES; PROVISION OF GENERAL PURPOSE FACILITIES FOR MEETINGS, CONFERENCES AND EXHIBITIONS; PROVISION OF BANQUETING AND SOCIAL FUNCTION FACILITIES FOR SPECIAL OCCASIONS; AND RESERVATION SERVICE FOR HOTEL ACCOMMODATIONS FOR OTHERS (U.S. CLS. 100 AND 101).

FIRST USE 7-31-2011; IN COMMERCE 7-31-2011.
ALLISON HOLTZ, EXAMINING ATTORNEY

SN 85-515,580. LORITO, TIMOTHY, HOLTSVILLE, NY. FILED 1-12-2012.

Do You Have a Crush on Our
Canz

THE MARK CONSISTS OF STANDARD CHARACTERS WITHOUT CLAIM TO ANY PARTICULAR FONT, STYLE, SIZE, OR COLOR.

FOR BAR SERVICES; RESTAURANT SERVICES (U.S. CLS. 100 AND 101).
FIRST USE 7-1-2010; IN COMMERCE 7-1-2010.
LINDA ORNDORFF, EXAMINING ATTORNEY

CLASS 44—MEDICAL, BEAUTY AND AGRICULTURAL SERVICES

SN 77-182,539. BROW, GEORGES R., GEORGETOWN, CANADA, FILED 5-16-2007.

smiling U

THE MARK CONSISTS OF STANDARD CHARACTERS WITHOUT CLAIM TO ANY PARTICULAR FONT, STYLE, SIZE, OR COLOR.

PRIORITY CLAIMED UNDER SEC. 44(D) ON CANADA APPLICATION NO. 1345858, FILED 5-2-2007, REG. NO. TMA798,581, DATED 5-26-2011, EXPIRES 5-26-2026.

FOR OPERATION OF PUBLIC TOILETS (U.S. CLS. 100 AND 101).

JAMES GRIFFIN, EXAMINING ATTORNEY

SN 77-183,497. BROW, GEORGES R., GEORGETOWN, CANADA, FILED 5-17-2007.

Überloo

THE MARK CONSISTS OF STANDARD CHARACTERS WITHOUT CLAIM TO ANY PARTICULAR FONT, STYLE, SIZE, OR COLOR.

PRIORITY CLAIMED UNDER SEC. 44(D) ON CANADA APPLICATION NO. 1347699, FILED 5-16-2007, REG. NO. TMA799,768, DATED 6-13-2011, EXPIRES 6-13-2026.

FOR OPERATION OF PUBLIC TOILETS (U.S. CLS. 100 AND 101).

JAMES GRIFFIN, EXAMINING ATTORNEY

SN 77-940,810. COMPREHENSIVE NEUROSCIENCE, INC., MIRAMAR, FL. FILED 2-21-2010.

BEHAVIORAL PHARMACY MANAGEMENT

THE MARK CONSISTS OF STANDARD CHARACTERS WITHOUT CLAIM TO ANY PARTICULAR FONT, STYLE, SIZE, OR COLOR.

SEC. 2(F).

FOR MEDICAL EVALUATION SERVICES, NAMELY, FUNCTIONAL ASSESSMENT PROGRAM FOR PATIENTS RECEIVING MEDICAL REHABILITATION SERVICES FOR PURPOSES OF GUIDING TREATMENT AND ASSESSING PROGRAM EFFECTIVENESS (U.S. CLS. 100 AND 101).

FIRST USE 12-31-2002; IN COMMERCE 12-31-2002.

LINDA E. BLOHM, EXAMINING ATTORNEY

CLASS 44—(Continued).

SN 85-120,548. HOUSTON PATIENT ADVOCACY, LLC, BELLAIRE, TX. FILED 9-1-2010.



NO CLAIM IS MADE TO THE EXCLUSIVE RIGHT TO USE "HOUSTON PATIENT ADVOCACY", APART FROM THE MARK AS SHOWN.

THE MARK CONSISTS OF THE ACRONYM "HPA" AND THE WORDS "HOUSTON PATIENT ADVOCACY" WITH A HORIZONTAL BAR SEPARATING THE WORDS "PROVIDING PATIENT EMPOWERMENT", WITH A VERTICAL BAR SEPARATING A STYLIZED HEART DESIGN WITH SILHOUETTES OF PEOPLE INSIDE.

FOR MEDICAL COUNSELING, NAMELY, PROVIDING MEDICAL COUNSELING SERVICES WHERE NON-TREATING PHYSICIANS ACT AS LIAISONS BETWEEN PATIENTS AND THE PATIENTS' MEDICAL PROVIDERS AND OTHER THIRD PARTIES AND DO NOT PROVIDE MEDICAL TREATMENT (U.S. CLS. 100 AND 101).

FIRST USE 8-14-2010; IN COMMERCE 8-31-2010.

ANDREA BUTLER, EXAMINING ATTORNEY

SN 85-127,709. GREYSON BARGER, DBA OPTICOLOGY EYECARE, LLC, WICHITA, KS. FILED 9-12-2010.

OPTICOLOGY

THE MARK CONSISTS OF STANDARD CHARACTERS WITHOUT CLAIM TO ANY PARTICULAR FONT, STYLE, SIZE, OR COLOR.

FOR OPTOMETRIC AND OPTICIAN SERVICES IN THE NATURE OF FITTING OF OPTICAL LENSES (U.S. CLS. 100 AND 101).

FIRST USE 7-1-2010; IN COMMERCE 9-1-2010.

BARBARA RUTLAND, EXAMINING ATTORNEY

CLASS 44—(Continued).

SN 85-250,864. PALMS IMAGING CENTER, LLC, OXNARD, CA. FILED 2-24-2011.



NO CLAIM IS MADE TO THE EXCLUSIVE RIGHT TO USE "SOFTTOUCH MAMMO", APART FROM THE MARK AS SHOWN.

THE MARK CONSISTS OF TWO INTERLOCKING SEMI-CIRCLES, WITH A HEART CENTERED WITHIN THE RIGHT-HAND SEMI-CIRCLE, AND CENTERED OVER THE WORDS "SOFTTOUCH MAMMO".

FOR MAMMOGRAPHY TESTING SERVICES (U.S. CLS. 100 AND 101).

FIRST USE 11-1-2008; IN COMMERCE 11-1-2008.

JOHN E. MICHOŠ, EXAMINING ATTORNEY

SN 85-283,894. HOMMAGE, INC., LITTLETON, CO. FILED 4-1-2011.

HOMMAGE ATELIER

THE MARK CONSISTS OF STANDARD CHARACTERS WITHOUT CLAIM TO ANY PARTICULAR FONT, STYLE, SIZE, OR COLOR.

PRIORITY CLAIMED UNDER SEC. 44(D) ON UNITED KINGDOM APPLICATION NO. 2566794, FILED 12-13-2010, REG. NO. 2566794, DATED 4-8-2011, EXPIRES 12-13-2020.

PRIORITY CLAIMED UNDER SEC. 44(D) ON UNITED KINGDOM APPLICATION NO. 2560570, FILED 10-5-2010, REG. NO. 2560570, DATED 4-15-2011, EXPIRES 10-5-2020.

OWNER OF U.S. REG. NOS. 3,197,694 AND 3,613,832.

NO CLAIM IS MADE TO THE EXCLUSIVE RIGHT TO USE "ATELIER", APART FROM THE MARK AS SHOWN.

THE ENGLISH TRANSLATION OF "HOMMAGE" IN THE MARK IS "HOMAGE".

FOR HAIR SALON SERVICES AND DAY SPA SERVICES FOR MEN, NAMELY, NAIL CARE, MANICURES, PEDICURES AND NAIL ENHANCEMENTS; PERSONAL GROOMING SERVICES FOR MEN, NAMELY, FACIALS, MASSAGES, BARBERING, BODY WAXING, MANICURES AND PEDICURES (U.S. CLS. 100 AND 101).

H. M. FISHER, EXAMINING ATTORNEY

CLASS 44—(Continued).

SN 85-293,260. NORTH FULTON MEDICAL CENTER, INC., DALLAS, TX. FILED 4-12-2011.



OWNER OF U.S. REG. NO. 3,933,521.

NO CLAIM IS MADE TO THE EXCLUSIVE RIGHT TO USE "NETWORK" OR "HOSPITAL", APART FROM THE MARK AS SHOWN.

THE COLOR(S) DARK GREEN, LIGHT GREEN, LIGHT PINK AND DARK PINK AND WHITE IS/ARE CLAIMED AS A FEATURE OF THE MARK.

THE MARK CONSISTS OF THE NUMBER "9" IN DARK GREEN AND THE WORDING "MONTH NETWORK AT NORTH FULTON HOSPITAL" IN WHITE, ALL SET WITHIN A STYLIZED RIBBON AND BANNER DESIGN CONSISTING OF LIGHT GREEN AND LIGHT PINK CONCENTRIC CIRCLES OUTLINED IN DARK GREEN WITH LIGHT PINK SCALLOPING AND DARK PINK OUTLINES APPEARING ABOVE A DARK GREEN ADVERTISING BANNER WITH LIGHT GREEN OUTLINING.

SEC. 2(F) "NORTH FULTON" HAS BECOME DISTINCTIVE OF THE GOODS/SERVICES AS EVIDENCED BY THE OWNERSHIP ON THE PRINCIPAL REGISTER FOR THE SAME MARK FOR RELATED GOODS OR SERVICES OF U.S. REGISTRATION NO(S). 3933521...

FOR HEALTH CARE (U.S. CLS. 100 AND 101).

SEAN CROWLEY, EXAMINING ATTORNEY

SN 85-296,954. LAURENCE ROGER, WEST HOLLYWOOD, CA. FILED 4-15-2011.

CHARLIE EN PARTICULIER

THE MARK CONSISTS OF STANDARD CHARACTERS WITHOUT CLAIM TO ANY PARTICULAR FONT, STYLE, SIZE, OR COLOR.

THE NAME(S), PORTRAIT(S), AND/OR SIGNATURE(S) SHOWN IN THE MARK DOES NOT IDENTIFY A PARTICULAR LIVING INDIVIDUAL.

THE ENGLISH TRANSLATION OF EN PARTICULIER IN THE MARK IS "IN PARTICULAR".

FOR BEAUTY SALON SERVICES (U.S. CLS. 100 AND 101).

KELLY BOULTON, EXAMINING ATTORNEY

CLASS 44—(Continued).

SN 85-300,281. WINSPIRATION WELLNESS, LLC, SPRING HILL, KS. FILED 4-20-2011.

WINSPIRATION WELLNESS

THE MARK CONSISTS OF STANDARD CHARACTERS WITHOUT CLAIM TO ANY PARTICULAR FONT, STYLE, SIZE, OR COLOR.

NO CLAIM IS MADE TO THE EXCLUSIVE RIGHT TO USE "WELLNESS", APART FROM THE MARK AS SHOWN.

FOR COUNSELING AND CONSULTING SERVICES IN THE FIELDS OF HEALTH AND NUTRITION; PROVIDING INFORMATION, NEWS AND COMMENTARY IN THE FIELDS OF HEALTH AND NUTRITION; PROVIDING WELLNESS SERVICES FOR HEALTH PURPOSES, NAMELY, PERSONAL ASSESSMENTS, PERSONALIZED ROUTINES, AND MAINTENANCE SCHEDULES; PROVIDING AN INTERACTIVE WEBSITE FEATURING HEALTH AND NUTRITION INFORMATION; PROVIDING PATIENT BENEFIT INFORMATION CONCERNING ORGANIC AND HOLISTIC PRODUCTS AND SERVICES (U.S. CLS. 100 AND 101).

KATHERINE CHANG, EXAMINING ATTORNEY

SN 85-301,713. UNITEDHEALTH GROUP INCORPORATED, MINNETONKA, MN. FILED 4-21-2011.

UNITEDHEALTHCARE

THE MARK CONSISTS OF STANDARD CHARACTERS WITHOUT CLAIM TO ANY PARTICULAR FONT, STYLE, SIZE, OR COLOR.

OWNER OF U.S. REG. NOS. 1,967,622, 3,269,588 AND OTHERS.

FOR MANAGED HEALTH CARE SERVICES; MANAGED HEALTH CARE SERVICES PROVIDED VIA A GLOBAL COMPUTER NETWORK; MANAGED VISION CARE SERVICES PROVIDED THROUGH A NETWORK OF VISION CARE PROVIDERS; MANAGED HEALTH CARE SERVICES IN THE FIELD OF VISION CARE; MANAGED HEALTH CARE SERVICES IN THE FIELD OF DISABILITY CARE; MANAGED HEALTH CARE SERVICES IN THE FIELD OF DENTAL CARE; MANAGED HEALTH CARE SERVICES IN THE FIELD OF DENTAL CARE VIA A GLOBAL COMPUTER NETWORK; MANAGED DENTAL HEALTH CARE SERVICES PROVIDED THROUGH A NETWORK OF DENTAL CARE PROVIDERS; MANAGED PHYSICAL THERAPY SERVICES PROVIDED THROUGH A NETWORK OF PHYSICAL THERAPY PROVIDERS; COMPLEMENTARY AND ALTERNATIVE MEDICINE SERVICES; MANAGED COMPLEMENTARY AND ALTERNATIVE MEDICINE SERVICES PROVIDED THROUGH A NETWORK OF COMPLEMENTARY AND ALTERNATIVE MEDICINE PROVIDERS TO HEALTH PLANS AND SELF-INSURED COMPANIES; NURSE TRIAGE AND NURSE CALL CENTERS PROVIDING INFORMATION REGARDING THE IDENTIFICATION OF SPECIFIC HEALTH-RELATED CONCERNS AND GENERAL HEALTH ISSUES; PRE-TRANSPLANT MEDICAL REVIEW PROGRAM FOR REINSURANCE AND INSURANCE COMPANIES, SELF-FUNDED EMPLOYERS AND HEALTH MAINTENANCE ORGANIZATIONS (HMOS) TO ASSESS MEDICAL EFFICACY OF TRANSPLANT-RELATED TECHNOLOGY AND PROVIDE RECOMMENDATIONS FOR TRANSPLANTS; PROVIDING HEALTH CARE INFORMATION ON CARE GIVING SERVICES,

CLASS 44—(Continued).

CARE MANAGEMENT SERVICES, AND PHARMACY AND OVER-THE-COUNTER PRODUCTS AND SERVICES; HEALTH CARE IN THE NATURE OF HEALTH MAINTENANCE ORGANIZATIONS (HMOS), PREFERRED PROVIDER ORGANIZATIONS (PPOS), AND CONSUMER DIRECTED HEALTH PLANS; EMPLOYEE ASSISTANCE SERVICES, NAMELY, PROVIDING ON-LINE, TELEPHONIC, AND IN-PERSON MEDICAL CONSULTATION, MEDICAL INFORMATION AND MEDICAL ASSESSMENT FOR PHYSICAL, AND MENTAL HEALTH, AND SUBSTANCE ABUSE; PROVIDING MEDICAL AND HEALTH-RELATED INFORMATION REGARDING THE SPECIALTIES, CREDENTIALS, EFFECTIVENESS, EXPERIENCE, EXPERTISE, EFFICIENCY AND QUALITY OF HEALTH CARE PROFESSIONALS AND HEALTH CARE PROVIDER ORGANIZATIONS TO HEALTH PLAN MEMBERS FOR USE IN EVALUATING AND SELECTING HEALTH CARE PROFESSIONALS AND HEALTH CARE PROVIDER ORGANIZATIONS; PROVIDING INTERACTIVE ONLINE SERVICES VIA A GLOBAL COMPUTER NETWORK UTILIZING INTERACTIVE COMPUTER MODULES, SOFTWARE TOOLS AND VIDEO MODULES FEATURING INFORMATION RELATING TO HEALTH, WELLNESS, AND HEALTH CARE SERVICES; PROVIDING HEALTH INFORMATION; PROVIDING HEALTH INFORMATION VIA THE INTERNET IN THE FIELDS OF HEALTH, WELLNESS, AND HEALTH CARE SERVICES; PROVIDING HEALTH AND WELLNESS INFORMATION; HEALTHCARE SERVICES IN THE NATURE OF PROVIDING PATIENT POPULATION HEALTH MANAGEMENT SERVICES FOR EMPLOYERS, NAMELY, WELLNESS MANAGEMENT, DISEASE PREVENTION MANAGEMENT AND DISEASE MANAGEMENT; PROVIDING HEALTH ASSESSMENT SERVICES TO EMPLOYERS AND EMPLOYEES, HEALTH RISK ASSESSMENTS AND HEALTH COACHING ASSESSMENTS IN THE NATURE OF PROVIDING PERSONAL HEALTH ASSESSMENTS CONSISTING OF HEALTH-RELATED INFORMATION IN THE FORM OF RECOMMENDED EDUCATIONAL RESOURCES AND TREATMENT INFORMATION; MEDICAL TESTING FOR DIAGNOSTIC OR TREATMENT PURPOSES; PROVIDING HEALTH INFORMATION AND ASSISTANCE IN THE NATURE OF PROVIDING HEALTH RISK APPRAISALS; HEALTH CARE SERVICES, NAMELY, DISEASE MANAGEMENT PROGRAMS, AND HEALTH AND WELLNESS PROGRAMS; MEDICAL SERVICES, NAMELY, ARRANGING MEDICAL CARE FOR NURSING HOME RESIDENTS; PROVIDING ON-LINE HEALTH AND MEDICAL INFORMATION (U.S. CLS. 100 AND 101).

AMY HELLA, EXAMINING ATTORNEY

CLASS 44—(Continued).

SN 85-303,121. ROBERTS, BRENDA LEE, DBA THE WHOLE SOUL GROUP, DALLAS, TX. FILED S.R. 4-24-2011; AM. P.R. 1-27-2012.



THE COLOR(S) ORANGE AND PURPLE IS/ARE CLAIMED AS A FEATURE OF THE MARK.

THE MARK CONSISTS OF THE WORDING "THE WHOLE SOUL" WITH "THE WHOLE" APPEARING IN PURPLE AND "SOUL" APPEARING IN ORANGE SURROUNDED BY THE DESIGN OF TWO BODIES TOUCHING WITH THE BODY ON THE LEFT IN ORANGE AND THE BODY ON THE RIGHT IN PURPLE.

FOR CLINICAL MENTAL HEALTH COUNSELING SERVICES; MENTAL HEALTH COUNSELING AND PSYCHOTHERAPY AS IT RELATES TO RELATIONSHIPS; PSYCHOLOGICAL COUNSELING; PSYCHOTHERAPY AND PSYCHOTHERAPY COUNSELING FOR CHILDREN AND ADULTS IN INDIVIDUAL AND FAMILY SESSIONS (U.S. CLS. 100 AND 101).

FIRST USE 11-4-2004; IN COMMERCE 11-4-2004.
ERIN FALK, EXAMINING ATTORNEY

CLASS 44—(Continued).

SN 85-310,343. KASTL, RASHILA, LONG GROVE, IL. FILED 5-2-2011.

BOLLYBROW

THE MARK CONSISTS OF STANDARD CHARACTERS WITHOUT CLAIM TO ANY PARTICULAR FONT, STYLE, SIZE, OR COLOR.

FOR FACIAL THREADING SERVICES; EYEBROW THREADING SERVICES; BEAUTY CONSULTATION SERVICES; BEAUTY SALON SERVICES; PROVIDING INFORMATION ABOUT BEAUTY; BEAUTY CONSULTATION SERVICES IN THE SELECTION AND USE OF COSMETICS, FRAGRANCES, BEAUTY AIDS, PERSONAL CARE PRODUCTS, AND BATH, BODY AND BEAUTY PRODUCTS; HAIR STYLING SERVICES; AESTHETICIAN SERVICES, NAMELY, COSMETICIAN SERVICES, COSMETIC FACE CARE AND SKIN CARE SERVICES (U.S. CLS. 100 AND 101).

ERNEST SHOSHO, EXAMINING ATTORNEY

SN 85-318,786. SCHERING CORPORATION, KENILWORTH, NJ. FILED 5-12-2011.

SN 85-306,080. EQUEST, WYLIE, TX. FILED 4-27-2011.



THE MARK CONSISTS OF "EQUEST" AND THE SILHOUETTE OF A HORSE AND RIDER JUMPING OVER THE MOON.

FOR PHYSICAL AND PSYCHOLOGICAL THERAPY FOR HUMANS WITH THE USE OF HORSES (U.S. CLS. 100 AND 101).

FIRST USE 1-30-1988; IN COMMERCE 1-30-1988.
ESTHER A. BORSUK, EXAMINING ATTORNEY



THE COLOR(S) ORANGE, BROWN, GREEN, YELLOW, BLACK, AND WHITE IS/ARE CLAIMED AS A FEATURE OF THE MARK.

THE MARK CONSISTS OF AN ORANGE AND BROWN CUBE CONTAINING A GREEN LEAF WITH A YELLOW STEM WITH WHITE AND BLACK EYES.

FOR PROVIDING AN INTERACTIVE WEB SITE FEATURING EDUCATIONAL INFORMATION ABOUT NASAL ALLERGIES (U.S. CLS. 100 AND 101).

CHRISTINE MARTIN, EXAMINING ATTORNEY

CLASS 44—(Continued).

SN 85-347,681. HOME SERVICES UNLIMITED, INC., AKA HSU; HOME SERVICES UNLIMITED, INDIANAPOLIS, IN. FILED 6-16-2011.



THE COLOR(S) ORANGE, BLUE AND WHITE IS/ARE CLAIMED AS A FEATURE OF THE MARK.

THE MARK CONSISTS OF THE LETTERS "HSU" IN THE COLOR BLUE, THE WORD "CARES" IN THE COLOR ORANGE, AND A SEMI-CIRCULAR DESIGN AROUND UPPER PART OF LOGO DOWN ALONG THE RIGHT SIDE TO THE LOWER RIGHT IN THE COLORS BLUE, ORANGE AND WHITE.

FOR HOME HEALTH CARE SERVICES (U.S. CLS. 100 AND 101).

FIRST USE 5-2-2011; IN COMMERCE 5-2-2011.
JOHN DWYER, EXAMINING ATTORNEY

SN 85-348,740. COMPREHENSIVE NEUROSCIENCE, INC., MIRAMAR, FL. FILED 6-17-2011.



NO CLAIM IS MADE TO THE EXCLUSIVE RIGHT TO USE "COMPREHENSIVE CLINICAL DEVELOPMENT", APART FROM THE MARK AS SHOWN.

THE MARK CONSISTS OF THE WORDS "COMPREHENSIVE" IN LARGER CAPITAL LETTERS WITH THE WORDS "CLINICAL DEVELOPMENT" OFFSET AND BELOW THE WORD "COMPREHENSIVE" AND WHERE THE "O" OF THE WORD "COMPREHENSIVE" IS MADE FROM A GRAPHIC OF A NOVA WITH A WIDER ELLIPTICAL ORBIT TRACED IN APPROXIMATELY AT 220 ARC AROUND THE NOVA.

FOR MEDICAL EVALUATION SERVICES; MEDICAL EVALUATION SERVICES, NAMELY, FUNCTIONAL ASSESSMENT PROGRAM FOR PATIENTS FOR PURPOSES OF GUIDING TREATMENT AND ASSESSING PROGRAM EFFECTIVENESS (U.S. CLS. 100 AND 101).

FIRST USE 3-30-2011; IN COMMERCE 3-30-2011.
MIDGE BUTLER, EXAMINING ATTORNEY

CLASS 44—(Continued).

SN 85-357,907. CONVATEC INC., SKILLMAN, NJ. FILED 6-28-2011.



OWNER OF U.S. REG. NOS. 1,139,439, 3,703,519 AND OTHERS.

THE MARK CONSISTS OF THE DESIGN OF A RECTANGLE FEATURING AN UPPER SECTION INCLUDING A DESIGN OF A HUMAN HAND HOLDING A TRAY WITH THE WORD "CONCIERGE" ABOVE THE TRAY. THE "O" IN "CONCIERGE" IS REPRESENTED BY A DESIGN OF A TEMPLE WITH A CAPSTONE AND THREE PILLARS WITHIN A CIRCULAR DESIGN. THE LOWER SECTION OF THE RECTANGLE FEATURES THE WORD "CONVA-TEC".

FOR MEDICAL INFORMATION; HEALTHCARE SERVICES, NAMELY, OSTOMY PATIENT SUPPORT SERVICES (U.S. CLS. 100 AND 101).

FIRST USE 2-28-2011; IN COMMERCE 2-28-2011.
KEVIN DINALLO, EXAMINING ATTORNEY

SN 85-364,853. STRICKLAND, TONY, LOS ANGELES, CA. FILED 7-7-2011.

SPORTS CARE CONNECT

THE MARK CONSISTS OF STANDARD CHARACTERS WITHOUT CLAIM TO ANY PARTICULAR FONT, STYLE, SIZE, OR COLOR.

NO CLAIM IS MADE TO THE EXCLUSIVE RIGHT TO USE "SPORTS CARE", APART FROM THE MARK AS SHOWN.

FOR PROVIDING HEALTH CARE SERVICES TO UNDERSERVED YOUTH AND YOUNG ADULT POPULATIONS (U.S. CLS. 100 AND 101).

ALICIA COLLINS, EXAMINING ATTORNEY

CLASS 44—(Continued).

SN 85-376,365. WILLIAMS, DAVID, MERRITT ISLAND, FL. FILED 7-20-2011.

MEDFAST URGENT CARE CENTERS

THE MARK CONSISTS OF STANDARD CHARACTERS WITHOUT CLAIM TO ANY PARTICULAR FONT, STYLE, SIZE, OR COLOR.

NO CLAIM IS MADE TO THE EXCLUSIVE RIGHT TO USE "UREGENT CARE CENTERS", APART FROM THE MARK AS SHOWN.

FOR URGENT MEDICAL CARE CENTERS (U.S. CLS. 100 AND 101).

JACLYN KIDWELL WALKER, EXAMINING ATTORNEY

SN 85-394,178. PASSPORT HEALTH COMMUNICATIONS, INC., FRANKLIN, TN. FILED 8-10-2011.

COVERAGE DISCOVERY

THE MARK CONSISTS OF STANDARD CHARACTERS WITHOUT CLAIM TO ANY PARTICULAR FONT, STYLE, SIZE, OR COLOR.

NO CLAIM IS MADE TO THE EXCLUSIVE RIGHT TO USE "COVERAGE", APART FROM THE MARK AS SHOWN.

FOR PROVISION OF HEALTHCARE INFORMATION BY ELECTRONIC MEANS (U.S. CLS. 100 AND 101).

MICHELE SWAIN, EXAMINING ATTORNEY

SN 85-410,650. SAAD, MOHAMED, DEARBORN, MI. FILED 8-30-2011.

EUROPEAN TANNING CLUB

THE MARK CONSISTS OF STANDARD CHARACTERS WITHOUT CLAIM TO ANY PARTICULAR FONT, STYLE, SIZE, OR COLOR.

NO CLAIM IS MADE TO THE EXCLUSIVE RIGHT TO USE "TANNING CLUB", APART FROM THE MARK AS SHOWN.

FOR TANNING SALONS (U.S. CLS. 100 AND 101).

FIRST USE 11-24-1999; IN COMMERCE 2-1-2000.

MARC LEIPZIG, EXAMINING ATTORNEY

CLASS 44—(Continued).

SN 85-413,680. CLINICAL LAB CONSULTING, LLC, CARMEL, IN. FILED 9-2-2011.

Laboratory Desk Reference

THE MARK CONSISTS OF STANDARD CHARACTERS WITHOUT CLAIM TO ANY PARTICULAR FONT, STYLE, SIZE, OR COLOR.

NO CLAIM IS MADE TO THE EXCLUSIVE RIGHT TO USE "LABORATORY" AND "REFERENCE", APART FROM THE MARK AS SHOWN.

FOR CONSULTING SERVICES IN THE FIELDS OF DIAGNOSTIC MEDICAL TESTING AND NUTRITION (U.S. CLS. 100 AND 101).

CHRIS WELLS, EXAMINING ATTORNEY

SN 85-415,464. NEW YORK PAIN MANAGEMENT GROUP, PLLC, NEW YORK, NY. FILED 9-6-2011.



NO CLAIM IS MADE TO THE EXCLUSIVE RIGHT TO USE "NY PAIN MANAGEMENT GROUP", APART FROM THE MARK AS SHOWN.

THE COLOR(S) BLUE AND GREEN IS/ARE CLAIMED AS A FEATURE OF THE MARK.

THE MARK CONSISTS OF THE FOLLOWING: A CIRCULAR INTERLOCKING BLUE "N" AND GREEN "Y", STYLIZED TO LOOK LIKE PEOPLE, WITH THE PHRASE "WE ALL DESERVE TO BE PAIN FREE" IN THE COLOR BLUE AROUND A BLUE AND GREEN CIRCULAR IMAGE, TO THE RIGHT OF WHICH IS THE PHRASE "PAIN MANAGEMENT GROUP" WITH THE WORDS "PAIN" AND "GROUP" IN THE COLOR BLUE AND THE WORD "MANAGEMENT" IN THE COLOR GREEN.

FOR MEDICAL SERVICES, NAMELY, PAIN MANAGEMENT (U.S. CLS. 100 AND 101).

FIRST USE 1-1-2011; IN COMMERCE 1-2-2011.

BARNEY CHARLON, EXAMINING ATTORNEY

CLASS 44—(Continued).

SN 85-421,720. JENSEN MAASS, DBA THE LAST RESORT, SOQUEL, CA. FILED 9-13-2011.



OWNER OF U.S. REG. NO. 3,345,906.
 THE MARK CONSISTS OF THE WORDING "THE LAST RESORT" SUPERIMPOSED OVER A STYLIZED BOTANICAL DRAWING OF FOLIAGE, WITH STYLIZED IMAGE OF WATER FLOWING FROM THE LETTER "O" IN THE WORD "RESORT".
 FOR HEALTH SPA SERVICES, NAMELY, BODY WRAPS, MUD TREATMENTS, SEAWEED TREATMENTS, HYDROTHERAPY BATHS, AND BODY SCRUBS (U.S. CLS. 100 AND 101).
 FIRST USE 7-1-2006; IN COMMERCE 7-1-2006.
 REGINA DRUMMOND, EXAMINING ATTORNEY

SN 85-424,197. CHURCH, PAMELA, V, PORTLAND, OR. FILED 9-15-2011.

Brain Update

THE MARK CONSISTS OF STANDARD CHARACTERS WITHOUT CLAIM TO ANY PARTICULAR FONT, STYLE, SIZE, OR COLOR.
 FOR CLINICAL MENTAL HEALTH COUNSELING SERVICES (U.S. CLS. 100 AND 101).
 FIRST USE 9-12-2011; IN COMMERCE 9-12-2011.
 REGINA DRUMMOND, EXAMINING ATTORNEY

CLASS 44—(Continued).

SN 85-429,767. MONTANA HEALTH SOLUTIONS, INC., MISSOULA, MT. FILED 9-22-2011.



NO CLAIM IS MADE TO THE EXCLUSIVE RIGHT TO USE "DIRECT CARE", APART FROM THE MARK AS SHOWN.
 THE COLOR(S) BLUE AND WHITE IS/ARE CLAIMED AS A FEATURE OF THE MARK.
 THE MARK CONSISTS OF THE WORDING "MY DIRECT CARE", FRAMED WITH A RECTANGULAR THICK, BLUE OUTER BORDER AND AN INTERIOR THIN, LIGHT BLUE BORDER. ADDITIONALLY, THE WORD "MY" IS ENCLOSED WITHIN A WHITE RECTANGLE. THE WORD "MY" IS IN BLUE TEXT AND THE WORDING "DIRECT CARE" IS IN WHITE TEXT.
 FOR HOME HEALTH CARE SERVICES; PROVIDING A WEBSITE FEATURING INFORMATION IN THE FIELD OF SELF-DIRECTED AND HOME HEALTH CARE SERVICES (U.S. CLS. 100 AND 101).
 FIRST USE 7-1-2009; IN COMMERCE 7-1-2009.
 LEIGH CAROLINE CASE, EXAMINING ATTORNEY

SN 85-434,602. DELTA DENTAL OF VIRGINIA, ROANOKE, VA. FILED 9-28-2011.



THE MARK CONSISTS OF TWO RECTANGULAR SHAPES ARRANGED HORIZONTALLY IN RELATION TO EACH OTHER AND SEPARATED FROM ONE ANOTHER BY SPACES, WITH THE PHRASE "THAT'S THE" SUPERIMPOSED ON THE RESPECTIVE RECTANGULAR BOXES, WITH ONE WORD APPEARING WITHIN EACH RECTANGLE, AND A THIRD RECTANGULAR SHAPE PLACED BENEATH THEM, SEPARATED BY A SPACE AND ALIGNED AT THE RIGHT MARGIN, WITH THE WORD "TROOTH" SUPERIMPOSED IN THAT RECTANGLE.
 FOR PROVIDING INFORMATION REGARDING ORAL DISEASE AND ITS CAUSES, SYMPTOMS, AND PREVENTION (U.S. CLS. 100 AND 101).
 FIRST USE 8-5-2011; IN COMMERCE 9-3-2011.
 LAURIE KAUFMAN, EXAMINING ATTORNEY

CLASS 44—(Continued).

SN 85-437,468. CENTENE CORPORATION, ST. LOUIS, MO. FILED 10-3-2011.

NURSE RESPONSE

THE MARK CONSISTS OF STANDARD CHARACTERS WITHOUT CLAIM TO ANY PARTICULAR FONT, STYLE, SIZE, OR COLOR.

OWNER OF U.S. REG. NO. 2,797,745.
NO CLAIM IS MADE TO THE EXCLUSIVE RIGHT TO USE "NURSE", APART FROM THE MARK AS SHOWN. SEC. 2(F).

FOR NURSE INFORMATION SERVICES, NAMELY, NURSE TRIAGE AND NURSE CALL CENTERS PROVIDING INFORMATION REGARDING THE IDENTIFICATION OF SPECIFIC HEALTH RELATED CONCERNS AND GENERAL HEALTH ISSUES (U.S. CLS. 100 AND 101).
FIRST USE 9-19-2002; IN COMMERCE 9-19-2002.
MARLENE BELL, EXAMINING ATTORNEY



SN 85-437,488. CENTENE CORPORATION, ST. LOUIS, MO. FILED 10-3-2011.

**NURSE RESPONSE CARE.
RIGHT. NOW.**

THE MARK CONSISTS OF STANDARD CHARACTERS WITHOUT CLAIM TO ANY PARTICULAR FONT, STYLE, SIZE, OR COLOR.

OWNER OF U.S. REG. NO. 2,797,745.
NO CLAIM IS MADE TO THE EXCLUSIVE RIGHT TO USE "NURSE", APART FROM THE MARK AS SHOWN.

FOR NURSE INFORMATION SERVICES, NAMELY, NURSE TRIAGE AND NURSE CALL CENTERS PROVIDING INFORMATION REGARDING THE IDENTIFICATION OF SPECIFIC HEALTH RELATED CONCERNS AND GENERAL HEALTH ISSUES (U.S. CLS. 100 AND 101).

FIRST USE 8-25-2011; IN COMMERCE 8-25-2011.
MARLENE BELL, EXAMINING ATTORNEY



SN 85-437,509. CENTENE CORPORATION, ST. LOUIS, MO. FILED 10-3-2011.

**PUTTING GREAT CARE INTO
GIVING GREAT CARE**

THE MARK CONSISTS OF STANDARD CHARACTERS WITHOUT CLAIM TO ANY PARTICULAR FONT, STYLE, SIZE, OR COLOR.

FOR NURSE INFORMATION SERVICES, NAMELY, NURSE TRIAGE AND NURSE CALL CENTERS PROVIDING INFORMATION REGARDING THE IDENTIFICATION OF SPECIFIC HEALTH RELATED CONCERNS AND GENERAL HEALTH; PROVIDING HEALTH CARE INFORMATION BY TELEPHONE (U.S. CLS. 100 AND 101).

MARLENE BELL, EXAMINING ATTORNEY

CLASS 44—(Continued).

SN 85-437,533. CENTENE CORPORATION, ST. LOUIS, MO. FILED 10-3-2011.

CARE. RIGHT. NOW.

THE MARK CONSISTS OF STANDARD CHARACTERS WITHOUT CLAIM TO ANY PARTICULAR FONT, STYLE, SIZE, OR COLOR.

FOR NURSE INFORMATION SERVICES, NAMELY, NURSE TRIAGE AND NURSE CALL CENTERS PROVIDING INFORMATION REGARDING THE IDENTIFICATION OF SPECIFIC HEALTH RELATED CONCERNS AND GENERAL HEALTH ISSUES; MANAGED HEALTH CARE SERVICES (U.S. CLS. 100 AND 101).

FIRST USE 7-25-2011; IN COMMERCE 7-25-2011.
MARLENE BELL, EXAMINING ATTORNEY



SN 85-438,662. MARY F. MURPHY, M.D., P.C., BOZEMAN, MT. FILED 10-4-2011.



NO CLAIM IS MADE TO THE EXCLUSIVE RIGHT TO USE "RADIOLOGY NETWORKS LLC", APART FROM THE MARK AS SHOWN.

THE MARK CONSISTS OF THE WORDING "RADIOLOGY NETWORKS LLC" SURROUNDED BY AN ARROW EXTENDING OFF THE LETTER "R".

FOR MEDICAL RADIOLOGY SERVICES (U.S. CLS. 100 AND 101).

FIRST USE 10-4-2011; IN COMMERCE 10-4-2011.
KAPIL BHANOT, EXAMINING ATTORNEY



SN 85-441,335. CALVERT ENTERPRISES, INC., NEWPORT BEACH, CA. FILED 10-6-2011.

ROX SURGICAL CENTER

THE MARK CONSISTS OF STANDARD CHARACTERS WITHOUT CLAIM TO ANY PARTICULAR FONT, STYLE, SIZE, OR COLOR.

NO CLAIM IS MADE TO THE EXCLUSIVE RIGHT TO USE "SURGICAL CENTER", APART FROM THE MARK AS SHOWN.

FOR SURGERY; COSMETIC AND PLASTIC SURGERY; MEDICAL SPA SERVICES, NAMELY, MINIMALLY AND NON-INVASIVE COSMETIC AND BODY FITNESS THERAPIES; PROVIDE A WEBSITE FEATURING INFORMATION ABOUT HOLISTIC COSMETIC AND PLASTIC SURGERY PRACTICE; MEDICAL CARE CENTERS (U.S. CLS. 100 AND 101).

SHAILA SETTLES, EXAMINING ATTORNEY

CLASS 44—(Continued).

SN 85-441,681. CALIFORNIA ORTHOPEDIC AND SPORTS THERAPY REHABILITATION SERVICES, INC. CAPITOLA, CA. FILED 10-7-2011.

CALIFORNIA ORTHOPEDIC AND SPORTS THERAPY

THE MARK CONSISTS OF STANDARD CHARACTERS WITHOUT CLAIM TO ANY PARTICULAR FONT, STYLE, SIZE, OR COLOR.

NO CLAIM IS MADE TO THE EXCLUSIVE RIGHT TO USE "ORTHODEIC AND SPORTS THERAPY", APART FROM THE MARK AS SHOWN.

SEC. 2(F).

FOR PHYSICAL THERAPY EVALUATION, IDENTIFICATION, AND MANAGEMENT OF MOVEMENT DYSFUNCTION TO RESTORE, MAINTAIN, AND PROMOTE OPTIMAL PHYSICAL FUNCTION PREVENTING THE ONSET, SYMPTOMS AND PROGRESSION OF IMPAIRMENTS, FUNCTIONAL LIMITATIONS, AND DISABILITIES RESULTING FROM DISEASE, DISORDERS, CONDITIONS, OR INJURIES (U.S. CLS. 100 AND 101).

FIRST USE 2-3-1995; IN COMMERCE 2-3-1995.
DANIEL CAPSHAW, EXAMINING ATTORNEY

CLASS 44—(Continued).

SN 85-442,348. PERFECT DIABETES CONTROL LLC, NEWNAN, GA. FILED 10-7-2011.

Perfect Diabetes Control

THE MARK CONSISTS OF STANDARD CHARACTERS WITHOUT CLAIM TO ANY PARTICULAR FONT, STYLE, SIZE, OR COLOR.

NO CLAIM IS MADE TO THE EXCLUSIVE RIGHT TO USE "DIABETES CONTROL", APART FROM THE MARK AS SHOWN.

FOR PROVIDING INFORMATION IN THE FIELD OF DIABETES (U.S. CLS. 100 AND 101).

FIRST USE 5-16-2011; IN COMMERCE 9-2-2011.
DAVID YONTEF, EXAMINING ATTORNEY

SN 85-442,649. WEIDNER RESORT DEVELOPMENT, INC., LAS VEGAS, NV. FILED 10-7-2011.

SN 85-441,831. OJCC, LLC, DBA THE BRIDGE CARE SUITES, SKOKIE, IL. FILED 10-7-2011.



NO CLAIM IS MADE TO THE EXCLUSIVE RIGHT TO USE "CARE SUITES", APART FROM THE MARK AS SHOWN.

THE COLOR(S) MAROON AND GRAY IS/ARE CLAIMED AS A FEATURE OF THE MARK.

THE MARK CONSISTS OF THE WORDING "THE BRIDGE CARE SUITES" IN MAROON APPEARING BELOW A GROUP NINE VERTICAL GRAY LINES OF VARYING HEIGHTS.

FOR HEALTH CARE IN THE NATURE OF LONG TERM AND SHORT TERM, IN-PATIENT, TRANSITIONAL AND PHYSICAL REHABILITATION HEALTH CARE SERVICES; PROVIDING LONG TERM AND SHORT TERM, TRANSITIONAL AND PHYSICAL REHABILITATION HEATH CARE SERVICES AND FACILITIES; SKILLED NURSING HOME SERVICES (U.S. CLS. 100 AND 101).

JULIE VEPPUMTHARA, EXAMINING ATTORNEY



THE MARK CONSISTS OF A RENDERING OF A PAGODA WITH CHINESE CHARACTERS TO THE RIGHT AND THE WORDS "XING GONG TRAVELING PALACE" BELOW THE RENDERING, WITH A HORIZONTAL LINE BELOW THE PAGODA AND THE WORDING.

THE ENGLISH TRANSLATION OF XING GONG IN THE MARK IS TRAVELING PALACE.

THE NON-LATIN CHARACTERS IN THE MARK TRANSLITERATE TO "XING GONG" AND THIS MEANS "TRAVELING PALACE" IN ENGLISH.

FOR BEAUTY SALONS; HEALTH SPA SERVICES FOR HEALTH AND WELLNESS OF THE BODY AND SPIRIT, NAMELY, PROVIDING MASSAGE, FACIAL AND BODY TREATMENT SERVICES, COSMETIC BODY CARE SERVICES; FLOWER ARRANGING (U.S. CLS. 100 AND 101).

ROBIN MITTLER, EXAMINING ATTORNEY

CLASS 44—(Continued).

SN 85-442,675. WEIDNER RESORT DEVELOPMENT, INC., LAS VEGAS, NV. FILED 10-7-2011.



THE MARK CONSISTS OF A RENDERING OF A GATE WITH CHINESE CHARACTERS TO THE RIGHT AND THE WORDS "XING GONG TRAVELING PALACE" BELOW THE RENDERING, WITH HORIZONTAL LINES ABOVE AND BELOW THE WORDING.

THE ENGLISH TRANSLATION OF "XING GONG" IN THE MARK IS TRAVELING PALACE.

THE NON-LATIN CHARACTERS IN THE MARK TRANSLITERATE TO "XING GONG" AND THIS MEANS "TRAVELING PALACE" IN ENGLISH.

FOR BEAUTY SALONS; HEALTH SPA SERVICES FOR HEALTH AND WELLNESS OF THE BODY AND SPIRIT, NAMELY, PROVIDING MASSAGE, FACIAL AND BODY TREATMENT SERVICES, COSMETIC BODY CARE SERVICES; FLOWER ARRANGING (U.S. CLS. 100 AND 101).
ROBIN MITTLER, EXAMINING ATTORNEY

SN 85-443,917. HEROES BARBERSHOPS, LLC, DEBARY, FL. FILED 10-11-2011.

HEROES BARBERSHOP

THE MARK CONSISTS OF STANDARD CHARACTERS WITHOUT CLAIM TO ANY PARTICULAR FONT, STYLE, SIZE, OR COLOR.

NO CLAIM IS MADE TO THE EXCLUSIVE RIGHT TO USE "BARBERSHOP", APART FROM THE MARK AS SHOWN.

FOR BEAUTY SALONS; BARBER SHOP SERVICES (U.S. CLS. 100 AND 101).

MEGHAN REINHART, EXAMINING ATTORNEY

CLASS 44—(Continued).

SN 85-444,423. ALI ENTERPRISES, INC., CULVER CITY, CA. FILED 10-11-2011.

My Herb Guy

THE MARK CONSISTS OF STANDARD CHARACTERS WITHOUT CLAIM TO ANY PARTICULAR FONT, STYLE, SIZE, OR COLOR.

NO CLAIM IS MADE TO THE EXCLUSIVE RIGHT TO USE "HERB", APART FROM THE MARK AS SHOWN.

FOR COUNSELING SERVICES IN THE FIELDS OF HEALTH, HERBALISM, AND LIFESTYLE WELLNESS (U.S. CLS. 100 AND 101).

FIRST USE 9-1-2001; IN COMMERCE 9-1-2001.
TARAH HARDY, EXAMINING ATTORNEY

SN 85-444,881. GENOVA DIAGNOSTICS, INC., ASHEVILLE, NC. FILED 10-11-2011.



THE COLOR(S) BLUE AND LIGHT GREEN IS/ARE CLAIMED AS A FEATURE OF THE MARK.

THE MARK CONSISTS OF "PRED" IN BLUE; "GUIDE" IN LIGHT GREEN, UNDER A LIGHT GREEN ARROW COMPRISING A PLURALITY OF DOTS POINTING UPWARD AND TO THE RIGHT IN A DIRECTION BEGINNING FROM A POINT BETWEEN THE "RE" PORTION OF THE WORD "PREDGUIDE".

FOR MEDICAL TESTING FOR DIAGNOSTIC OR TREATMENT PURPOSES (U.S. CLS. 100 AND 101).

FIRST USE 12-1-2010; IN COMMERCE 12-1-2010.
LESLIE RICHARDS, EXAMINING ATTORNEY

SN 85-445,415. OLIVER, GREGORY, INDIANAPOLIS, IN. FILED 10-12-2011.

HealthQuicken

THE MARK CONSISTS OF STANDARD CHARACTERS WITHOUT CLAIM TO ANY PARTICULAR FONT, STYLE, SIZE, OR COLOR.

FOR COUNSELING SERVICES IN THE FIELDS OF HEALTH, NUTRITION AND LIFESTYLE WELLNESS; PROVIDING WEIGHT LOSS PROGRAM SERVICES (U.S. CLS. 100 AND 101).

FIRST USE 10-1-2010; IN COMMERCE 10-1-2010.
ERIN FALK, EXAMINING ATTORNEY

CLASS 44—(Continued).

SN 85-445,620. BAY CENTER FOR JAW SURGERY, P.A., LARGO, FL. FILED 10-12-2011.



THE MARK CONSISTS OF A CONCH SHELL DESIGN. FOR MEDICAL SERVICES, NAMELY ORAL AND MAXILLOFACIAL AND FACIAL RECONSTRUCTION SURGERY (U.S. CLS. 100 AND 101). FIRST USE 8-10-1986; IN COMMERCE 8-10-1986. JENNIFER DIXON, EXAMINING ATTORNEY

SN 85-445,840. STOP AGING NOW, LLC, BETHESDA, MD. FILED 10-12-2011.



OWNER OF U.S. REG. NO. 3,930,176. NO CLAIM IS MADE TO THE EXCLUSIVE RIGHT TO USE "YOUR GUIDE TO NATURAL HEALTH", APART FROM THE MARK AS SHOWN. THE COLOR(S) GREEN, YELLOW, BLACK, AND GRAY IS/ARE CLAIMED AS A FEATURE OF THE MARK. THE MARK CONSISTS OF A STYLIZED YELLOW SUN RISING OVER A CURVED, GREEN HILL, WITH THE LARGE GREEN WORD "LIVE" TO THE LEFT OF THE SUN, THE SMALL, BLACK WORDS "IN THE" STACKED ON TOP OF EACH OTHER UNDER "LIVE", AND THE LARGER GREEN WORD "NOW" TO THE LEFT OF "IN THE". BENEATH THE SUN, HILL AND WORDS "LIVE IN THE NOW", AND SCROLLING FROM LEFT TO RIGHT, ARE THE SMALLER GRAY WORDS "YOUR GUIDE TO NATURAL HEALTH". FOR PROVIDING A WEBSITE FEATURING INFORMATION ABOUT HEALTH, WELLNESS AND NUTRITION (U.S. CLS. 100 AND 101). FIRST USE 10-5-2011; IN COMMERCE 10-5-2011. ROBERT C. CLARK JR., EXAMINING ATTORNEY

CLASS 44—(Continued).

SN 85-446,305. CORD:USE CORD BLOOD BANK, INC., ORLANDO, FL. FILED 10-13-2011.

THE TEAM THAT DID IT FIRST. THE TEAM THAT DOES IT BEST.

THE MARK CONSISTS OF STANDARD CHARACTERS WITHOUT CLAIM TO ANY PARTICULAR FONT, STYLE, SIZE, OR COLOR. FOR COLLECTION AND PRESERVATION OF HUMAN BLOOD; CORD BLOOD BANK SERVICES; PRESERVATION OF UMBILICAL CORD BLOOD FOR POTENTIAL USE AS A SOURCE OF STEM CELLS (U.S. CLS. 100 AND 101). KAREN K. BUSH, EXAMINING ATTORNEY

SN 85-446,329. RAPSON, PATCHARA, HOUSTON, TX. AND SMITH, MATTHEW, HOUSTON, TX. FILED 10-13-2011.

THAI EXPERIENCE

THE MARK CONSISTS OF STANDARD CHARACTERS WITHOUT CLAIM TO ANY PARTICULAR FONT, STYLE, SIZE, OR COLOR. NO CLAIM IS MADE TO THE EXCLUSIVE RIGHT TO USE "THAI", APART FROM THE MARK AS SHOWN. FOR MASSAGE THERAPY SERVICES (U.S. CLS. 100 AND 101). FIRST USE 0-0-2006; IN COMMERCE 0-0-2006. WILLIAM JACKSON, EXAMINING ATTORNEY

SN 85-446,376. DAIGLE, KAREN, SOUTHERN PINES, NC. FILED 10-13-2011.

Fithippie

THE MARK CONSISTS OF STANDARD CHARACTERS WITHOUT CLAIM TO ANY PARTICULAR FONT, STYLE, SIZE, OR COLOR. FOR CONSULTING SERVICES IN THE FIELDS OF HEALTH, NUTRITION AND LIFESTYLE WELLNESS (U.S. CLS. 100 AND 101). WILLIAM ROSSMAN, EXAMINING ATTORNEY

CLASS 44—(Continued).

SN 85-446,647. CORD:USE CORD BLOOD BANK, INC., ORLANDO, FL. FILED 10-13-2011.

BANK WITH CONFIDENCE

THE MARK CONSISTS OF STANDARD CHARACTERS WITHOUT CLAIM TO ANY PARTICULAR FONT, STYLE, SIZE, OR COLOR.

FOR COLLECTION AND PRESERVATION OF HUMAN BLOOD; CORD BLOOD BANK SERVICES; PRESERVATION OF UMBILICAL CORD BLOOD FOR POTENTIAL USE AS A SOURCE OF STEM CELLS (U.S. CLS. 100 AND 101).

KAREN K. BUSH, EXAMINING ATTORNEY

SN 85-446,703. CORD:USE CORD BLOOD BANK, INC., ORLANDO, FL. FILED 10-13-2011.

BANK FOR THE FUTURE

THE MARK CONSISTS OF STANDARD CHARACTERS WITHOUT CLAIM TO ANY PARTICULAR FONT, STYLE, SIZE, OR COLOR.

FOR COLLECTION AND PRESERVATION OF HUMAN BLOOD; CORD BLOOD BANK SERVICES; PRESERVATION OF UMBILICAL CORD BLOOD FOR POTENTIAL USE AS A SOURCE OF STEM CELLS (U.S. CLS. 100 AND 101).

KAREN K. BUSH, EXAMINING ATTORNEY

SN 85-446,781. CHRISTALENE SALDANHA, BEL AIR, MD. FILED 10-13-2011.

GET A SHOT AT LIFE!

THE MARK CONSISTS OF STANDARD CHARACTERS WITHOUT CLAIM TO ANY PARTICULAR FONT, STYLE, SIZE, OR COLOR.

FOR MEDICAL SERVICES AND TREATMENT FOR REHABILITATION OF DRUG AND ALCOHOL ADDICTED PATIENTS; ADMINISTERING DRUG INJECTIONS TO PREVENT CRAVINGS FOR DRUGS AND/OR ALCOHOL IN CONNECTION WITH THE TREATMENT AND RECOVERY OF DRUG AND ALCOHOL ADDICTION (U.S. CLS. 100 AND 101).

GENE MACIOL, EXAMINING ATTORNEY

CLASS 44—(Continued).

SN 85-446,787. JONES EYE CENTER, P.C., SIOUX CITY, IA. FILED 10-13-2011.

FACESTHETICS

THE MARK CONSISTS OF STANDARD CHARACTERS WITHOUT CLAIM TO ANY PARTICULAR FONT, STYLE, SIZE, OR COLOR.

FOR EYE CARE AND FACIAL SURGERY (U.S. CLS. 100 AND 101).

GENE MACIOL, EXAMINING ATTORNEY

SN 85-446,984. MIRYALA, ANI, OXFORD, FL. FILED 10-13-2011.

U2

THE MARK CONSISTS OF STANDARD CHARACTERS WITHOUT CLAIM TO ANY PARTICULAR FONT, STYLE, SIZE, OR COLOR.

FOR HEALTH SPA SERVICES FOR HEALTH AND WELLNESS OF THE BODY AND SPIRIT, NAMELY, PROVIDING MASSAGE, FACIAL AND BODY TREATMENT SERVICES, COSMETIC BODY CARE SERVICES (U.S. CLS. 100 AND 101).

JOHN GARTNER, EXAMINING ATTORNEY

SN 85-447,012. MIRYALA, ANI, OXFORD, FL. FILED 10-13-2011.

U2 new U

THE MARK CONSISTS OF STANDARD CHARACTERS WITHOUT CLAIM TO ANY PARTICULAR FONT, STYLE, SIZE, OR COLOR.

FOR HEALTH SPA SERVICES FOR HEALTH AND WELLNESS OF THE BODY AND SPIRIT, NAMELY, PROVIDING MASSAGE, FACIAL AND BODY TREATMENT SERVICES, COSMETIC BODY CARE SERVICES (U.S. CLS. 100 AND 101).

JOHN GARTNER, EXAMINING ATTORNEY

CLASS 44—(Continued).

SN 85-447,035. SOLACE HEALTHCARE, INC., DENVER, CO. FILED 10-13-2011.



NO CLAIM IS MADE TO THE EXCLUSIVE RIGHT TO USE "HEALTHCARE", APART FROM THE MARK AS SHOWN.

THE MARK CONSISTS OF A HALF CIRCLE WITH A WAVE DESIGN UNDERNEATH FOLLOWED BY THE WORD "SOLACE" AND "HEALTHCARE" UNDERNEATH.

FOR PHYSICAL THERAPY, OCCUPATIONAL THERAPY, SPEECH AND HEARING THERAPY, PHYSICAL THERAPY EVALUATION, IDENTIFICATION, AND MANAGEMENT OF MOVEMENT DYSFUNCTION TO RESTORE, MAINTAIN, AND PROMOTE OPTIMAL PHYSICAL FUNCTION PREVENTING THE ONSET, SYMPTOMS AND PROGRESSION OF IMPAIRMENTS, FUNCTIONAL LIMITATIONS, AND DISABILITIES RESULTING FROM DISEASE, DISORDERS, CONDITIONS, OR INJURIES, PHYSICAL THERAPY IN THE NATURE OF MOVEMENT THERAPY; SPEECH AND HEARING THERAPY, SPEECH PATHOLOGY THERAPY SERVICES; NURSING SERVICES; HOME HEALTH CARE SERVICES; HOME VISIT NURSING CARE; PEDIATRIC HEALTH CARE SERVICES (U.S. CLS. 100 AND 101).

EDWARD NELSON, EXAMINING ATTORNEY

CLASS 44—(Continued).

SN 85-447,129. BENSON, NENA, ATASCADERO, CA. FILED 10-13-2011.



NO CLAIM IS MADE TO THE EXCLUSIVE RIGHT TO USE "VINO+THERAPY STUDIO", APART FROM THE MARK AS SHOWN.

THE MARK CONSISTS OF A WINE BOTTLE LAYING ON ITS SIDE SURROUNDED BY A RECTANGLE. INSIDE THE BOTTLE IS THE STYLIZED TEXT "VINO+THERAPY". THERE IS A WAVY LINE AT THE BOTTOM OF THE NECK OF THE BOTTLE THAT REPRESENTS LIQUID. UNDER THE NECK OF THE BOTTLE IS THE STYLIZED TEXT "STUDIO".

FOR HEALTH SPA SERVICES FOR HEALTH AND WELLNESS OF THE BODY AND SPIRIT; HEALTH SPA SERVICES, NAMELY, COSMETIC BODY CARE SERVICES (U.S. CLS. 100 AND 101).

FIRST USE 2-1-2011; IN COMMERCE 2-1-2011.

NAPOLEON SHARMA, EXAMINING ATTORNEY

SN 85-447,179. HAIR RESTORATION INSTITUTE, BLOOMINGTON, MN. FILED 10-13-2011.

NO MORE DRUGS, RUGS OR PLUGS

THE MARK CONSISTS OF STANDARD CHARACTERS WITHOUT CLAIM TO ANY PARTICULAR FONT, STYLE, SIZE, OR COLOR.

FOR HAIR REPLACEMENT, HAIR ADDITION, AND HAIR EXTENSION SERVICES (U.S. CLS. 100 AND 101).

FONG HSU, EXAMINING ATTORNEY

SN 85-447,062. DR. KEITH KRAMER, PEORIA, IL. FILED 10-13-2011.



THE COLOR(S) GREEN, AQUA AND BLUE IS/ARE CLAIMED AS A FEATURE OF THE MARK.

THE MARK CONSISTS OF THE WORD SENARA. THE FIRST TWO LETTERS IN SENARA, S AND E, APPEAR IN REGULAR GREEN FONT. THE THIRD LETTER IN SENARA, N, APPEARS IN STYLIZED GREEN FONT. THE LAST THREE LETTERS IN SENARA, A, R, AND A APPEAR IN REGULAR GREEN FONT. THE STYLIZED N HAS AN EXTENDED CROSS LINE WHICH EXTENDS FROM THE UPPER LEFT TO THE BOTTOM RIGHT. THE TOP OF THE EXTENDED CROSS LINE ON THE UPPER LEFT IS SPLIT INTO A V SHAPE. TWO IMAGES OF LEAVES APPEAR OVER THE V SHAPE, WITH ONE LEAF BLUE IN COLOR EXTENDING UP AND TO THE LEFT, AND THE OTHER LEAF AQUA IN COLOR EXTENDING UP AND TO THE RIGHT. THE BODY OF THE LEAVES INTERSECT AND FORM AN OVAL DIRECTLY ABOVE THE FORK IN THE V SHAPE OF THE EXTENDED CROSS LINE.

FOR ACUPUNCTURE SERVICES; CHIROPRACTIC SERVICES; HEALTH SPA SERVICES FOR HEALTH AND WELLNESS OF THE BODY AND SPIRIT (U.S. CLS. 100 AND 101).

ASMAT KHAN, EXAMINING ATTORNEY

SN 85-447,325. RAND, GREGORY JAMES, LOS ANGELES, CA. FILED 10-14-2011.

UVASUN

THE MARK CONSISTS OF STANDARD CHARACTERS WITHOUT CLAIM TO ANY PARTICULAR FONT, STYLE, SIZE, OR COLOR.

FOR TANNING SALONS (U.S. CLS. 100 AND 101).

FIRST USE 4-1-1982; IN COMMERCE 4-1-1996.

GEOFFREY FOSDICK, EXAMINING ATTORNEY

CLASS 44—(Continued).

SN 85-447,681. BLUE CROSS AND BLUE SHIELD OF SOUTH CAROLINA, INC., COLUMBIA, SC. FILED 10-14-2011.

WALK AROUND THE WORLD

THE MARK CONSISTS OF STANDARD CHARACTERS WITHOUT CLAIM TO ANY PARTICULAR FONT, STYLE, SIZE, OR COLOR.

FOR HEALTH CARE SERVICES, NAMELY, WELLNESS PROGRAMS (U.S. CLS. 100 AND 101).
MICHAEL KEATING, EXAMINING ATTORNEY

SN 85-447,769. BRETT ALLRED, VANCOUVER, WA. FILED 10-14-2011.



FOR HAIR AND BEAUTY SALON SERVICES (U.S. CLS. 100 AND 101).
FIRST USE 1-1-2011; IN COMMERCE 1-1-2011.
MARK RADEMACHER, EXAMINING ATTORNEY

SN 85-447,796. BRETT ALLRED, VANCOUVER, WA. FILED 10-14-2011.



FOR HAIR AND BEAUTY SALON SERVICES (U.S. CLS. 100 AND 101).
FIRST USE 1-1-2011; IN COMMERCE 1-1-2011.
MARK RADEMACHER, EXAMINING ATTORNEY

CLASS 44—(Continued).

SN 85-447,817. BRETT ALLRED, VANCOUVER, WA. FILED 10-14-2011.

BEIGEBLOND

THE MARK CONSISTS OF STANDARD CHARACTERS WITHOUT CLAIM TO ANY PARTICULAR FONT, STYLE, SIZE, OR COLOR.

FOR HAIR AND BEAUTY SALON SERVICES (U.S. CLS. 100 AND 101).
FIRST USE 1-1-2011; IN COMMERCE 1-1-2011.
MARK RADEMACHER, EXAMINING ATTORNEY

SN 85-447,990. TELADOC, INC., DALLAS, TX. FILED 10-14-2011.

Teladoc⁺Connect

OWNER OF U.S. REG. NOS. 3,119,711, 3,873,546 AND 3,990,956.

THE MARK CONSISTS OF A STYLED PLUS SIGN APPEARING BETWEEN THE WORDS TELADOC AND CONNECT.

FOR MEDICAL SERVICES, NAMELY, PROVIDING MEDICAL SERVICES AND CONSULTATION OVER THE TELEPHONE AND OTHER TELECOMMUNICATION DEVICES (U.S. CLS. 100 AND 101).
RONALD MCMORROW, EXAMINING ATTORNEY

SN 85-448,001. THE 15-40 CONNECTION, INC., WORCESTER, MA. FILED 10-14-2011.

Got Symptoms? Act Early.

THE MARK CONSISTS OF STANDARD CHARACTERS WITHOUT CLAIM TO ANY PARTICULAR FONT, STYLE, SIZE, OR COLOR.

FOR PROVIDING A WEBSITE VIA A GLOBAL COMPUTER NETWORK FEATURING INFORMATION AND COMPREHENSIVE CONTENT IN THE FIELDS OF HEALTH, CANCER, CANCER RECOVERY AND SURVIVAL (U.S. CLS. 100 AND 101).
MAYUR VAGHANI, EXAMINING ATTORNEY

CLASS 44—(Continued).

SN 85-448,047. MEDICAL ANESTHESIA CONSULTANTS, DBA WELLMOMMY.COM, HOUSTON, TX. FILED 10-14-2011.

WellMommy

THE MARK CONSISTS OF STANDARD CHARACTERS WITHOUT CLAIM TO ANY PARTICULAR FONT, STYLE, SIZE, OR COLOR.

FOR CONSULTING IN THE FIELD OF HEALTH AND WELLNESS TO BRING ABOUT PERSONAL HAPPINESS (U.S. CLS. 100 AND 101).

FIRST USE 9-15-2008; IN COMMERCE 10-12-2011.

PAUL MORENO, EXAMINING ATTORNEY

SN 85-448,440. ANIMAL EMERGENCY CRITICAL CARE ASSOCIATES, LEESBURG, VA. FILED 10-16-2011.



NO CLAIM IS MADE TO THE EXCLUSIVE RIGHT TO USE "ANIMAL EMERGENCY CRITICAL CARE. 24 HOUR CARE YOU CAN TRUST", APART FROM THE MARK AS SHOWN.

THE COLOR(S) RED, GRAY AND BLUE IS/ARE CLAIMED AS A FEATURE OF THE MARK.

THE MARK CONSISTS OF A RED STYLIZED PAW PRINT WITH THE PAD OF THE PAW IN THE SHAPE OF A HEART. THE HEART IS FORMED AS A STYLIZED STETHOSCOPE IN GRAY THAT IS CENTERED ABOVE THE GRAY WORDS "ANIMAL EMERGENCY CRITICAL CARE" AND THE BLUE WORDS "24 HOUR CARE YOU CAN TRUST". A RED VERTICAL LINE IS LOCATED BETWEEN THE WORDS "ANIMAL" AND "EMERGENCY".

FOR VETERINARY EMERGENCY AND TRAUMA SERVICES (U.S. CLS. 100 AND 101).

FIRST USE 8-13-2009; IN COMMERCE 8-13-2009.

WILLIAM VERHOSEK, EXAMINING ATTORNEY

SN 85-448,516. THE 15-40 CONNECTION, INC., WORCESTER, MA. FILED 10-17-2011.

Tune In. Sound Off. Beat Cancer.

THE MARK CONSISTS OF STANDARD CHARACTERS WITHOUT CLAIM TO ANY PARTICULAR FONT, STYLE, SIZE, OR COLOR.

FOR PROVIDING A WEBSITE VIA A GLOBAL COMPUTER NETWORK FEATURING INFORMATION AND COMPREHENSIVE CONTENT IN THE FIELDS OF HEALTH, CANCER, CANCER RECOVERY AND SURVIVAL (U.S. CLS. 100 AND 101).

MAYUR VAGHANI, EXAMINING ATTORNEY

CLASS 44—(Continued).

SN 85-448,557. CONRAD FAFARD, INC., AGAWAM, MA. FILED 10-17-2011.

Creation Station

THE MARK CONSISTS OF STANDARD CHARACTERS WITHOUT CLAIM TO ANY PARTICULAR FONT, STYLE, SIZE, OR COLOR.

FOR PROVIDING CONSULTATION SERVICES FOR THE MIXING AND USE OF PLANT SEEDS AND POTTING SOIL; GARDENING SERVICES, NAMELY, ARRANGING OF PLANTS AND FLOWERS AND THE REPOTTING OF PLANTS FOR OTHERS (U.S. CLS. 100 AND 101).

BARBARA GAYNOR, EXAMINING ATTORNEY

SN 85-448,593. UPTOWN PAW, IRVINE, CA. FILED 10-17-2011.



THE MARK CONSISTS OF A SQUARE CONTAINING AN IMAGE OF A STANDARD POODLE IN A SHOW CLIP. TO THE RIGHT IS THE STYLIZED TEXT "UPTOWN PAW" WHERE "UPTOWN" IS ABOVE "PAW".

FOR ANIMAL GROOMING SERVICES (U.S. CLS. 100 AND 101).

FIRST USE 3-7-2005; IN COMMERCE 3-7-2005.

THOMAS MANOR, EXAMINING ATTORNEY

SN 85-448,683. CHC WELLNESS, INC., CHICAGO, IL. FILED 10-17-2011.

WALK TO HEALTH

THE MARK CONSISTS OF STANDARD CHARACTERS WITHOUT CLAIM TO ANY PARTICULAR FONT, STYLE, SIZE, OR COLOR.

FOR HEALTH CARE SERVICES, NAMELY, HEALTH AND WELLNESS PROGRAMS; WELLNESS AND HEALTH-RELATED CONSULTING SERVICES; PROVIDING INFORMATION IN THE FIELD OF HEALTH, WELLNESS, NUTRITION, AND WEIGHT LOSS (U.S. CLS. 100 AND 101).

KATHLEEN LORENZO, EXAMINING ATTORNEY

CLASS 44—(Continued).

SN 85-448,697. CHC WELLNESS, INC., CHICAGO, IL. FILED 10-17-2011.

WALK TO HEALTH...ONE STEP
AT A TIME!

THE MARK CONSISTS OF STANDARD CHARACTERS WITHOUT CLAIM TO ANY PARTICULAR FONT, STYLE, SIZE, OR COLOR.

FOR HEALTH CARE SERVICES, NAMELY, HEALTH AND WELLNESS PROGRAMS; WELLNESS AND HEALTH-RELATED CONSULTING SERVICES; PROVIDING INFORMATION IN THE FIELD OF HEALTH, WELLNESS, NUTRITION, AND WEIGHT LOSS (U.S. CLS. 100 AND 101).

KATHLEEN LORENZO, EXAMINING ATTORNEY

SN 85-448,779. THE TRUSTEES OF THE DEGREGORI FAMILY TRUST, NEWPORT BEACH, CA. FILED 10-17-2011.

TRUTH N HEALTH

THE MARK CONSISTS OF STANDARD CHARACTERS WITHOUT CLAIM TO ANY PARTICULAR FONT, STYLE, SIZE, OR COLOR.

FOR PROVIDING A WEBSITE FEATURING INFORMATION ABOUT HEALTH, WELLNESS AND NUTRITION (U.S. CLS. 100 AND 101).

FIRST USE 10-12-2011; IN COMMERCE 10-12-2011.
JAMES LOVELACE, EXAMINING ATTORNEY

SN 85-448,781. THE TRUSTEES OF THE DEGREGORI FAMILY TRUST, NEWPORT BEACH, CA. FILED 10-17-2011.



THE MARK CONSISTS OF A TREE POSITIONED ABOVE THE TERMS "TRUTH N HEALTH".

FOR PROVIDING A WEBSITE FEATURING INFORMATION ABOUT HEALTH, WELLNESS AND NUTRITION (U.S. CLS. 100 AND 101).

FIRST USE 10-12-2011; IN COMMERCE 10-12-2011.
JAMES LOVELACE, EXAMINING ATTORNEY

CLASS 44—(Continued).

SN 85-448,854. TORRES, MARLENA, MILLERSVILLE, PA. FILED 10-17-2011.

health through indulgence

THE MARK CONSISTS OF STANDARD CHARACTERS WITHOUT CLAIM TO ANY PARTICULAR FONT, STYLE, SIZE, OR COLOR.

FOR COUNSELING SERVICES IN THE FIELDS OF HEALTH, NUTRITION AND LIFESTYLE WELLNESS (U.S. CLS. 100 AND 101).

FIRST USE 6-10-2011; IN COMMERCE 6-10-2011.
BERNICE MIDDLETON, EXAMINING ATTORNEY

SN 85-448,911. REALAGE, INC., SAN DIEGO, CA. FILED 10-17-2011.

SEXAGE

THE MARK CONSISTS OF STANDARD CHARACTERS WITHOUT CLAIM TO ANY PARTICULAR FONT, STYLE, SIZE, OR COLOR.

OWNER OF U.S. REG. NOS. 2,801,158, 3,216,403 AND OTHERS.

FOR PROVIDING HEALTH INFORMATION; PROVIDING A WEBSITE FEATURING INFORMATION ON HEALTH AND NUTRITION; CONSULTING SERVICES IN THE FIELD OF HEALTH (U.S. CLS. 100 AND 101).

FIRST USE 9-9-2011; IN COMMERCE 9-9-2011.
MARK T. MULLEN, EXAMINING ATTORNEY

SN 85-449,631. ARBORGUARD, INC., AVONDALE ESTATES, GA. FILED 10-18-2011.

ArborGrow

THE MARK CONSISTS OF STANDARD CHARACTERS WITHOUT CLAIM TO ANY PARTICULAR FONT, STYLE, SIZE, OR COLOR.

FOR TREE CARE SERVICES, NAMELY SOIL INJECTION APPLICATION OF PRODUCTS TO TREES (U.S. CLS. 100 AND 101).

FIRST USE 7-12-2004; IN COMMERCE 7-12-2004.
MICHAEL KEATING, EXAMINING ATTORNEY

CLASS 44—(Continued).

SN 85-449,828. ACADIA HEALTHCARE COMPANY, INC., FRANKLIN, TN. FILED 10-18-2011.

ACADIA

THE MARK CONSISTS OF STANDARD CHARACTERS WITHOUT CLAIM TO ANY PARTICULAR FONT, STYLE, SIZE, OR COLOR.
FOR PSYCHIATRIC SERVICES (U.S. CLS. 100 AND 101).
FIRST USE 5-0-2006; IN COMMERCE 5-0-2006.
GINA HAYES, EXAMINING ATTORNEY

SN 85-449,838. ACADIA HEALTHCARE COMPANY, INC., FRANKLIN, TN. FILED 10-18-2011.



THE MARK CONSISTS OF THE STYLIZED WORD ACADIA.
FOR PSYCHIATRIC SERVICES (U.S. CLS. 100 AND 101).
FIRST USE 5-0-2006; IN COMMERCE 5-0-2006.
GINA HAYES, EXAMINING ATTORNEY

SN 85-449,860. ST. VINCENT CARMEL HOSPITAL, INC., CARMEL, IN. FILED 10-18-2011.

**A Call to L.I.F.E.
Lifetime of Individual
Fitness and Eating**

THE MARK CONSISTS OF STANDARD CHARACTERS WITHOUT CLAIM TO ANY PARTICULAR FONT, STYLE, SIZE, OR COLOR.
FOR HEALTH CARE SERVICES, NAMELY, THE PROVISION OF HEALTH CARE SERVICES RELATED TO BARIATRIC SURGERY AND THE PROVISION OF WEIGHT LOSS MANAGEMENT SERVICES (U.S. CLS. 100 AND 101).
JAY FLOWERS, EXAMINING ATTORNEY

CLASS 44—(Continued).

SN 85-450,001. WOJABOOTY, INC., DBA WOJABOOTY, EVERETT, WA. FILED 10-18-2011.

Woojabooty

THE MARK CONSISTS OF STANDARD CHARACTERS WITHOUT CLAIM TO ANY PARTICULAR FONT, STYLE, SIZE, OR COLOR.
FOR PROVIDING A WEBSITE FEATURING INFORMATION ABOUT HEALTH, WELLNESS AND NUTRITION (U.S. CLS. 100 AND 101).
ALYSSA STEEL, EXAMINING ATTORNEY

SN 85-450,053. SHEARER, ROBERT, NASHVILLE, TN. FILED 10-18-2011.

EMERGYNCARE

THE MARK CONSISTS OF STANDARD CHARACTERS WITHOUT CLAIM TO ANY PARTICULAR FONT, STYLE, SIZE, OR COLOR.
FOR OBSTETRIC AND GYNECOLOGY SERVICES (U.S. CLS. 100 AND 101).
NAAKWAMA ANKRAH, EXAMINING ATTORNEY

SN 85-450,074. INNOVATIVE PEDIATRICS, LLC, NAPLES, FL. FILED 10-18-2011.

INPEDS

THE MARK CONSISTS OF STANDARD CHARACTERS WITHOUT CLAIM TO ANY PARTICULAR FONT, STYLE, SIZE, OR COLOR.
FOR PROVIDING MEDICAL CONCIERGE SERVICES AND GENERAL PEDIATRIC MEDICAL SERVICES FOR OTHERS, NAMELY, MEDICAL TREATMENT AND DIAGNOSIS (U.S. CLS. 100 AND 101).
FIRST USE 9-27-2011; IN COMMERCE 9-27-2011.
KAREN K. BUSH, EXAMINING ATTORNEY

CLASS 44—(Continued).

SN 85-450,387. GILBERT HOSPITAL, LLC, GILBERT, AZ. FILED 10-18-2011.

DOOR TO DOC

THE MARK CONSISTS OF STANDARD CHARACTERS WITHOUT CLAIM TO ANY PARTICULAR FONT, STYLE, SIZE, OR COLOR.

OWNER OF U.S. REG. NOS. 3,741,479 AND 3,875,830. FOR HOSPITAL SERVICES, NAMELY, EMERGENCY SERVICES AND ACUTE CARE SERVICES (U.S. CLS. 100 AND 101).

ROBERT C. CLARK JR., EXAMINING ATTORNEY

SN 85-451,508. SALT CHALET, LLC, ENCINO, CA. FILED 10-19-2011.

SALT CHALET

THE MARK CONSISTS OF STANDARD CHARACTERS WITHOUT CLAIM TO ANY PARTICULAR FONT, STYLE, SIZE, OR COLOR.

NO CLAIM IS MADE TO THE EXCLUSIVE RIGHT TO USE "SALT", APART FROM THE MARK AS SHOWN.

FOR HEALTH SPA SERVICES FOR HEALTH AND WELLNESS OF THE BODY AND SPIRIT (U.S. CLS. 100 AND 101).

FIRST USE 11-1-2009; IN COMMERCE 9-5-2010. LAURIE MAYES, EXAMINING ATTORNEY

SN 85-451,522. FIFTH STREET GAMING, LLC, LAS VEGAS, NV. FILED 10-19-2011.

DOWNTOWN GRAND

THE MARK CONSISTS OF STANDARD CHARACTERS WITHOUT CLAIM TO ANY PARTICULAR FONT, STYLE, SIZE, OR COLOR.

FOR BARBER SHOP SERVICES; BEAUTY SALON SERVICES; COSMETICIAN SERVICES; DAY SPA SERVICES, NAMELY, NAIL CARE, MANICURES, PEDICURES AND NAIL ENHANCEMENTS; HEALTH SPA SERVICES FOR HEALTH AND WELLNESS OF THE BODY AND SPIRIT, NAMELY, PROVIDING MASSAGE, FACIAL AND BODY TREATMENT SERVICES, COSMETIC BODY CARE SERVICES; TANNING SALONS (U.S. CLS. 100 AND 101).

DAVID HOFFMAN, EXAMINING ATTORNEY

CLASS 44—(Continued).

SN 85-451,558. NORTHWEST CANCER CLINIC, LLC, TRICITIES, WA. FILED 10-19-2011.



THE COLOR(S) BLUE AND YELLOW IS/ARE CLAIMED AS A FEATURE OF THE MARK.

THE MARK CONSISTS OF THE ARTISTIC RENDERING OF A RIBBON IN BLUE WITH THE SILHOUETTE OF A HUMAN HEAD AND ARMS IN BLUE APPEARING ABOVE THE RIBBON. THREE SEMI-CIRCLES IN YELLOW APPEAR AT THE END OF THE RIGHT ARM.

FOR MEDICAL SERVICES: CANCER TREATMENT SERVICES (U.S. CLS. 100 AND 101).

JOHN WILKE, EXAMINING ATTORNEY

SN 85-452,255. BEAUTY BENDER, LLC, LOS ANGELES, CA. FILED 10-20-2011.

Beauty Formula

THE MARK CONSISTS OF STANDARD CHARACTERS WITHOUT CLAIM TO ANY PARTICULAR FONT, STYLE, SIZE, OR COLOR.

NO CLAIM IS MADE TO THE EXCLUSIVE RIGHT TO USE "BEAUTY", APART FROM THE MARK AS SHOWN.

FOR PROVIDING NEWS AND INFORMATION IN THE FIELD OF PERSONAL BEAUTY (U.S. CLS. 100 AND 101).

DAVID HOFFMAN, EXAMINING ATTORNEY

CLASS 44—(Continued).

SN 85-461,086. PATIENT FORWARD, LLC, DRIPPING SPRINGS, TX. FILED 11-1-2011.

**Promoting Wellness Through
Access and Innovation**

THE MARK CONSISTS OF STANDARD CHARACTERS WITHOUT CLAIM TO ANY PARTICULAR FONT, STYLE, SIZE, OR COLOR.

FOR TELEMEDICINE SERVICES; CONSULTING SERVICES IN THE FIELD OF PROVIDING CONSUMERS ACCESS TO HEALTH CARE, WELLNESS CARE, HEALTH CARE PROFESSIONALS AND WELLNESS CARE PROFESSIONALS VIA COMPUTER, TELEPHONE OR OTHER ELECTRONIC MEANS (U.S. CLS. 100 AND 101).

DORITT L. CARROLL, EXAMINING ATTORNEY

SN 85-462,953. EDWARDS LIFESCIENCES CORPORATION, IRVINE, CA. FILED 11-2-2011.

1.800.FOGARTY

THE MARK CONSISTS OF STANDARD CHARACTERS WITHOUT CLAIM TO ANY PARTICULAR FONT, STYLE, SIZE, OR COLOR.

OWNER OF U.S. REG. NOS. 1,172,120, 3,013,908 AND OTHERS.

FOR MEDICAL SERVICES RELATING TO THE TREATMENT OF PERSONS VIA INTERVENTIONAL CARDIOLOGY (U.S. CLS. 100 AND 101).

FIRST USE 0-0-2003; IN COMMERCE 0-0-2003.
JOHN HWANG, EXAMINING ATTORNEY

SN 85-468,553. REALAGE, INC., SAN DIEGO, CA. FILED 11-9-2011.

EATINGAGE

THE MARK CONSISTS OF STANDARD CHARACTERS WITHOUT CLAIM TO ANY PARTICULAR FONT, STYLE, SIZE, OR COLOR.

OWNER OF U.S. REG. NOS. 2,155,113, 3,838,485 AND OTHERS.

FOR CONSULTING SERVICES IN THE FIELDS OF HEALTH AND NUTRITION; PROVIDING HEALTH INFORMATION (U.S. CLS. 100 AND 101).

MARK T. MULLEN, EXAMINING ATTORNEY

CLASS 44—(Continued).

SN 85-468,574. REALAGE, INC., SAN DIEGO, CA. FILED 11-9-2011.

PROSTATEAGE

THE MARK CONSISTS OF STANDARD CHARACTERS WITHOUT CLAIM TO ANY PARTICULAR FONT, STYLE, SIZE, OR COLOR.

OWNER OF U.S. REG. NOS. 2,155,113, 3,838,485 AND OTHERS.

FOR CONSULTING SERVICES IN THE FIELDS OF HEALTH AND NUTRITION; PROVIDING HEALTH INFORMATION (U.S. CLS. 100 AND 101).

MARK T. MULLEN, EXAMINING ATTORNEY

SN 85-468,586. REALAGE, INC., SAN DIEGO, CA. FILED 11-9-2011.

ORALHEALTHAGE

THE MARK CONSISTS OF STANDARD CHARACTERS WITHOUT CLAIM TO ANY PARTICULAR FONT, STYLE, SIZE, OR COLOR.

OWNER OF U.S. REG. NOS. 2,155,113, 3,838,485 AND OTHERS.

FOR CONSULTING SERVICES IN THE FIELDS OF HEALTH AND NUTRITION; PROVIDING HEALTH INFORMATION (U.S. CLS. 100 AND 101).

MARK T. MULLEN, EXAMINING ATTORNEY

SN 85-468,598. REALAGE, INC., SAN DIEGO, CA. FILED 11-9-2011.

REALMANAGE

THE MARK CONSISTS OF STANDARD CHARACTERS WITHOUT CLAIM TO ANY PARTICULAR FONT, STYLE, SIZE, OR COLOR.

OWNER OF U.S. REG. NOS. 2,155,113, 3,838,485 AND OTHERS.

FOR CONSULTING SERVICES IN THE FIELDS OF HEALTH AND NUTRITION; PROVIDING HEALTH INFORMATION (U.S. CLS. 100 AND 101).

MARK T. MULLEN, EXAMINING ATTORNEY

CLASS 44—(Continued).

SN 85-468,609. REALAGE, INC., SAN DIEGO, CA. FILED 11-9-2011.

REALWOMANAGE

THE MARK CONSISTS OF STANDARD CHARACTERS WITHOUT CLAIM TO ANY PARTICULAR FONT, STYLE, SIZE, OR COLOR.

OWNER OF U.S. REG. NOS. 2,155,113, 3,838,485 AND OTHERS.

FOR CONSULTING SERVICES IN THE FIELDS OF HEALTH AND NUTRITION; PROVIDING HEALTH INFORMATION (U.S. CLS. 100 AND 101).

MARK T. MULLEN, EXAMINING ATTORNEY

SN 85-471,252. OPTIMA HEALTH SOLUTIONS INTERNATIONAL CORPORATION, VANCOUVER, BC, CANADA, FILED 11-13-2011.

SPINALYTICS

THE MARK CONSISTS OF STANDARD CHARACTERS WITHOUT CLAIM TO ANY PARTICULAR FONT, STYLE, SIZE, OR COLOR.

FOR MEDICAL IMAGING SERVICES, NAMELY, CONSULTING SERVICES IN THE FIELD OF USING AND OPERATING MEDICAL IMAGING APPARATUS INCLUDING X-RAY, COMPUTED TOMOGRAPHY, MAGNETIC RESONANCE IMAGING, ULTRASOUND, AND POSITRON EMISSION TOMOGRAPHY APPARATUS (U.S. CLS. 100 AND 101).

FIRST USE 0-0-2009; IN COMMERCE 0-0-2009.
NANCY CLARKE, EXAMINING ATTORNEY

SN 85-478,585. ADRIFT FLOAT SPA, LLC, SUNNYVALE, TX. FILED 11-22-2011.

ADRIFT FLOAT SPA

THE MARK CONSISTS OF STANDARD CHARACTERS WITHOUT CLAIM TO ANY PARTICULAR FONT, STYLE, SIZE, OR COLOR.

NO CLAIM IS MADE TO THE EXCLUSIVE RIGHT TO USE "FLOAT SPA", APART FROM THE MARK AS SHOWN.

FOR HEALTH SPA SERVICES FOR HEALTH AND WELLNESS OF THE BODY AND SPIRIT (U.S. CLS. 100 AND 101).

FIRST USE 7-30-2010; IN COMMERCE 2-14-2011.
NAPOLEON SHARMA, EXAMINING ATTORNEY

CLASS 44—(Continued).

SN 85-499,919. HELENA HOLDING COMPANY, WILMINGTON, DE. FILED 12-20-2011.

AGOPTIC

THE MARK CONSISTS OF STANDARD CHARACTERS WITHOUT CLAIM TO ANY PARTICULAR FONT, STYLE, SIZE, OR COLOR.

FOR FIELD SCOUTING AGRICULTURAL AND HORTICULTURAL SERVICES, NAMELY, PROVIDING AGRICULTURAL AND HORTICULTURAL ADVICE TO IMPROVE CROP PRODUCTION BASED ON MONITORED AND RECORDED DATA (U.S. CLS. 100 AND 101).

DAVID YONTEF, EXAMINING ATTORNEY

SN 85-515,434. TELADOC, INC., DALLAS, TX. FILED 1-12-2012.

TELADOC CONNECT

THE MARK CONSISTS OF STANDARD CHARACTERS WITHOUT CLAIM TO ANY PARTICULAR FONT, STYLE, SIZE, OR COLOR.

OWNER OF U.S. REG. NOS. 3,119,711, 3,873,546 AND 3,990,956.

FOR MEDICAL SERVICES, NAMELY, PROVIDING MEDICAL SERVICES AND CONSULTATION OVER THE TELEPHONE AND OTHER TELECOMMUNICATION DEVICES (U.S. CLS. 100 AND 101).

RONALD MCMORROW, EXAMINING ATTORNEY

SN 85-522,594. TELADOC, INC., DALLAS, TX. FILED 1-23-2012.



The logo for Teladoc Connect features the word "Teladoc" in a bold, sans-serif font, with a stylized plus sign (+) to its upper right. Below "Teladoc" is the word "Connect" in a larger, bold, sans-serif font.

OWNER OF U.S. REG. NOS. 3,119,711, 3,873,546 AND 3,990,956.

THE MARK CONSISTS OF THE WORD "TELADOC" WITH A STYLIZED PLUS SIGN APPEARING TO THE UPPER RIGHT OF THE LETTER "C" ALL OF WHICH APPEAR OVER THE WORD "CONNECT".

FOR MEDICAL SERVICES, NAMELY, PROVIDING MEDICAL SERVICES AND CONSULTATION OVER THE TELEPHONE AND OTHER TELECOMMUNICATION DEVICES (U.S. CLS. 100 AND 101).

RONALD MCMORROW, EXAMINING ATTORNEY

CLASS 45—PERSONAL AND LEGAL SERVICES

SN 85-151,639. AOL INC., DULLES, VA. FILED 10-13-2010.

CLASS 45—(Continued).

SN 85-215,850. HUMANA INC., LOUISVILLE, KY. FILED 1-12-2011.

HUMANA HOMECARE SOLUTIONS

MENSWIRE

THE MARK CONSISTS OF STANDARD CHARACTERS WITHOUT CLAIM TO ANY PARTICULAR FONT, STYLE, SIZE, OR COLOR.

PRIORITY CLAIMED UNDER SEC. 44(D) ON ERPNCMNTY TM OFC APPLICATION NO. 9401506, FILED 9-24-2010, REG. NO. 9401506, DATED 3-8-2011, EXPIRES 9-24-2020. FOR PROVIDING A WEBSITE FEATURING INFORMATION ON LIFESTYLES (U.S. CLS. 100 AND 101).

KRISTINA MORRIS, EXAMINING ATTORNEY

THE MARK CONSISTS OF STANDARD CHARACTERS WITHOUT CLAIM TO ANY PARTICULAR FONT, STYLE, SIZE, OR COLOR.

OWNER OF U.S. REG. NOS. 2,213,478, 3,497,184 AND OTHERS.

NO CLAIM IS MADE TO THE EXCLUSIVE RIGHT TO USE "HOMECARE SOLUTIONS", APART FROM THE MARK AS SHOWN.

FOR GERIATRIC HEALTH CARE MANAGEMENT SERVICES, NAMELY, COORDINATING SERVICES AND PERSONAL CARE FOR SENIORS; PROVIDING INFORMATION AND RECOMMENDATIONS ABOUT NON-MEDICAL PERSONAL SUPPORT SERVICES FOR SENIORS AND INDIVIDUALS; PROVIDING NON-MEDICAL IN-HOME PERSONAL SERVICES FOR INDIVIDUALS AND SENIORS, NAMELY, SAFETY ASSESSMENTS AND RECOMMENDATIONS RELATING TO HOME CONDITION; PROVIDING PATIENT ADVOCATE AND CASE MANAGEMENT SERVICES, NAMELY, COORDINATING THE PROCUREMENT AND ADMINISTRATION OF MEDICATION; PROVIDING PATIENT ADVOCATE INFORMATION TO SENIORS, INDIVIDUALS AND CAREGIVERS IN THE FIELD OF PROCUREMENT AND ADMINISTRATION OF MEDICATIONS (U.S. CLS. 100 AND 101).

REGINA DRUMMOND, EXAMINING ATTORNEY

SN 85-172,336. MILLIKEN & COMPANY, SPARTANBURG, SC. FILED 11-9-2010.

SN 85-237,202. SECUREALERT, INC., SANDY, UT. FILED 2-8-2011.

Milliken

TRUEDETECT

OWNER OF U.S. REG. NOS. 896,986, 3,648,244 AND OTHERS.

THE MARK CONSISTS OF "MILLIKEN" IN CURSIVE WRITING.

SEC. 2(F). FOR CONSULTING IN THE FIELD OF WORKPLACE SAFETY (U.S. CLS. 100 AND 101).

LINDA ESTRADA, EXAMINING ATTORNEY

THE MARK CONSISTS OF STANDARD CHARACTERS WITHOUT CLAIM TO ANY PARTICULAR FONT, STYLE, SIZE, OR COLOR.

FOR ELECTRONIC MONITORING SERVICES FOR SECURITY PURPOSES, NAMELY, REMOTE MONITORING AND TRACKING OF INDIVIDUALS IN NEED OF SUPERVISION OR MONITORING FOR SECURITY PURPOSES (U.S. CLS. 100 AND 101).

KEVIN CORWIN, EXAMINING ATTORNEY

CLASS 45—(Continued).

SN 85-301,726. UNITEDHEALTH GROUP INCORPORATED, MINNETONKA, MN. FILED 4-21-2011.

UNITEDHEALTHCARE

THE MARK CONSISTS OF STANDARD CHARACTERS WITHOUT CLAIM TO ANY PARTICULAR FONT, STYLE, SIZE, OR COLOR.

OWNER OF U.S. REG. NOS. 1,967,622, 3,269,588 AND OTHERS.

FOR CASE MANAGEMENT SERVICES, NAMELY, COORDINATING HEALTH CARE SERVICES PROVIDED TO ELDERLY AND CHRONICALLY ILL POPULATIONS BY DOCTORS AND OTHER HEALTH CARE PROVIDERS; CASE MANAGEMENT SERVICES, NAMELY, COORDINATION OF NECESSARY MEDICAL SERVICES, SOCIAL SERVICES, PERSONAL CARE SERVICES, AND TRANSPORTATION TO MEDICAL APPOINTMENTS; HEALTH CARE ADVOCACY SERVICES TO MEMBERS OF HEALTH BENEFIT PLANS; INDIVIDUALIZED HEALTH CARE COORDINATION SERVICES, NAMELY, FACILITATING AN ARRAY OF SERVICES, NAMELY, MEDICAL CARE SERVICES, BEHAVIORAL HEALTH SERVICES, AND HEALTH CARE MANAGEMENT; ON-LINE SOCIAL NETWORKING SERVICES; PROVIDING ON-LINE COMPUTER DATABASES AND ON-LINE SEARCHABLE DATABASES IN THE FIELD OF SOCIAL NETWORKING (U.S. CLS. 100 AND 101).

AMY HELLA, EXAMINING ATTORNEY

SN 85-304,944. FRESH START WOMEN'S FOUNDATION, PHOENIX, AZ. FILED 4-26-2011.



NO CLAIM IS MADE TO THE EXCLUSIVE RIGHT TO USE "WOMEN'S FOUNDATION", APART FROM THE MARK AS SHOWN.

THE MARK CONSISTS OF THE WORDS "FRESH START WOMEN'S FOUNDATION" AND THE DESIGN OF THE SILHOUETTE OF THE UPPER HALF OF A WOMAN WITH HER ARMS RAISED ABOVE HER HEAD.

FOR ORGANIZING AND CONDUCTING SUPPORT GROUPS IN THE AREAS OF ENTREPRENEURSHIP, CO-DEPENDENCY, DOMESTIC VIOLENCE, BEREAVEMENT AND ALCOHOL ADDICTION (U.S. CLS. 100 AND 101).

FIRST USE 10-0-2002; IN COMMERCE 10-0-2002.
JUDITH HELFMAN, EXAMINING ATTORNEY

CLASS 45—(Continued).

SN 85-306,060. INTERNATIONAL MISSION BOARD OF THE SOUTHERN BAPTIST CONVENTION, RICHMOND, VA. FILED 4-27-2011.



THE MARK CONSISTS OF THE STYLIZED LOWER CASE LETTERS "IMB" WITH THE SCRIPT WORD "CONNECTING" UNDERNEATH AND SLIGHTLY TO THE RIGHT OF THE LETTERS "IMB".

FOR PROVIDING A WEBSITE FEATURING INFORMATION IN THE FIELD OF WORLD EVANGELISM AND CHRISTIAN MISSIONS; PROVIDING A WEBSITE FEATURING ONLINE RESOURCES ABOUT RELIGIOUS BELIEF SYSTEMS FOR CHURCHES AND INDIVIDUALS REGARDING WORLD EVANGELISM AND CHRISTIAN MISSIONS (U.S. CLS. 100 AND 101).

FIRST USE 6-15-2009; IN COMMERCE 6-15-2009.
JULIE GUTTADAURO, EXAMINING ATTORNEY

SN 85-306,069. INTERNATIONAL MISSION BOARD OF THE SOUTHERN BAPTIST CONVENTION, RICHMOND, VA. FILED 4-27-2011.



THE MARK CONSISTS OF THE STYLIZED LOWER CASE LETTERS "IMB" WITH THE SCRIPT WORD "CONNECTING" UNDERNEATH AND SLIGHTLY TO THE RIGHT OF THE LETTERS "IMB".

FOR PROVIDING A WEBSITE FEATURING INFORMATION AND NON-DOWNLOADABLE PHOTOGRAPHIC, AUDIO, AND VIDEO PRESENTATIONS IN THE FIELD OF MISSIONARY, EVANGELISTIC AND MINISTERIAL SERVICES CONSISTENT WITH THE PROCLAMATION OF THE GOSPEL OF JESUS CHRIST AND OTHER MINISTERIAL SERVICES (U.S. CLS. 100 AND 101).

FIRST USE 6-15-2009; IN COMMERCE 6-15-2009.
JULIE GUTTADAURO, EXAMINING ATTORNEY

CLASS 45—(Continued).

SN 85-310,368. CORBIS CORPORATION, NEW YORK, NY. FILED 5-2-2011.

GREENLIGHT MUSIC

THE MARK CONSISTS OF STANDARD CHARACTERS WITHOUT CLAIM TO ANY PARTICULAR FONT, STYLE, SIZE, OR COLOR.

OWNER OF U.S. REG. NO. 3,632,669.

NO CLAIM IS MADE TO THE EXCLUSIVE RIGHT TO USE "MUSIC", APART FROM THE MARK AS SHOWN.

FOR LICENSING OF INTELLECTUAL PROPERTY RIGHTS AND COPYRIGHTS; CONSULTATION SERVICES AND PROVIDING INFORMATION RELATED TO MANAGEMENT OF MUSIC COPYRIGHTS AND MUSIC COPYRIGHT LICENSING; CLEARANCE OF RIGHTS TO COPYRIGHTED MATERIAL FOR LICENSING TO OTHERS; MUSICAL COPYRIGHT LICENSING AGENCY SERVICES, NAMELY, LICENSING OF COPYRIGHTS; LICENSING OF INTELLECTUAL PROPERTY RIGHTS AND COPYRIGHTS TO DIGITAL MEDIA ITEMS, NAMELY, DIGITAL MUSIC, DIGITAL VIDEOS, DIGITAL IMAGES, AUDIOVISUAL CONTENT, DIGITAL SOUND FILES FOR OTHERS (U.S. CLS. 100 AND 101).

ANTHONY RINKER, EXAMINING ATTORNEY

SN 85-313,035. LOWER SHORE ENTERPRISES, INC., SALISBURY, MD. FILED 5-5-2011.

disABILITIES

THE MARK CONSISTS OF STANDARD CHARACTERS WITHOUT CLAIM TO ANY PARTICULAR FONT, STYLE, SIZE, OR COLOR.

FOR LIFE QUALITY ASSESSMENT FOR INDIVIDUALS WITH DEVELOPMENTAL DISABILITIES AND THEIR FAMILIES (U.S. CLS. 100 AND 101).

FIRST USE 2-1-2008; IN COMMERCE 2-1-2008.
MATTHEW KLINE, EXAMINING ATTORNEY

CLASS 45—(Continued).

SN 85-325,801. NAPIER DIVERSIFIED SERVICES, INC., DBA TRUCKINGEXPERT.COM, MACON, GA. FILED 5-20-2011.



NO CLAIM IS MADE TO THE EXCLUSIVE RIGHT TO USE "TRUCKINGEXPERT.COM" AND "DIVERSIFIED SERVICES, INC.", APART FROM THE MARK AS SHOWN.

THE COLOR(S) BLACK, WHITE, RED, BLUE AND GRAY IS/ARE CLAIMED AS A FEATURE OF THE MARK.

THE MARK CONSISTS OF A BLACK TRACTOR TRAILER WITH WHITE OUTLINING AND DETAILING WITH GRAY SCALES BEHIND THE TRACTOR TRAILER. THE TRACTOR TRAILER IS EMERGING FROM THE LEFT BOTTOM SIDE OF A RED CIRCULAR BORDER. THE CIRCLE IS WHITE IN THE CENTER WITH BLUE SHADOWING AROUND THE INNER RIM OF THE CIRCLE. THE WORDING "TRUCKINGEXPERT.COM" APPEARS IN BLACK STYLIZED FONT CURVING AROUND THE TOP PORTION OF THE CIRCLE. THE WORDING "NAPIER DIVERSIFIED SERVICES, INC." APPEARS IN BLACK STYLIZED FONT CURVING AROUND THE BOTTOM PORTION OF THE CIRCLE. THERE IS A SMALL RED CIRCLE BETWEEN THE WORDING ".COM" AND ".INC.".

FOR EXPERT WITNESS SERVICES IN LEGAL MATTERS IN THE FIELD OF TRACTOR TRAILER LITIGATION (U.S. CLS. 100 AND 101).

FIRST USE 11-28-2010; IN COMMERCE 11-28-2010.
TINA BROWN, EXAMINING ATTORNEY

SN 85-336,045. COMP OPTIONS INSURANCE COMPANY, INC., JACKSONVILLE, FL. FILED 6-2-2011.

CIRCANA

THE MARK CONSISTS OF STANDARD CHARACTERS WITHOUT CLAIM TO ANY PARTICULAR FONT, STYLE, SIZE, OR COLOR.

FOR PATIENT ADVOCACY AND COUNSELING FOR BOTH FOREIGNERS AND UNITED STATES RESIDENTS THROUGHOUT THE PROCESS OF SEEKING AND SECURING MEDICAL CARE OUTSIDE THEIR HOME COUNTRY (U.S. CLS. 100 AND 101).

CAROLINE WOOD, EXAMINING ATTORNEY

CLASS 45—(Continued).

SN 85-341,029. CHRISTIANS FOR ISRAEL INTERNATIONAL, NIJKERK, NETHERLANDS, FILED 6-8-2011.

CHRISTIANS FOR ISRAEL

THE MARK CONSISTS OF STANDARD CHARACTERS WITHOUT CLAIM TO ANY PARTICULAR FONT, STYLE, SIZE, OR COLOR.

SEC. 2(F).

FOR MINISTERIAL SERVICES; PROVIDING INFORMATION, AND PROVIDING INFORMATION VIA A GLOBAL COMMUNICATIONS NETWORK, IN THE FIELDS OF CHRISTIANITY, JUDAISM, BIBLICAL PROPHECY AND HISTORY, AND MINISTRY TO JEWS AND PEOPLE IN ISRAEL; PROVIDING A WEBSITE FEATURING INFORMATIONAL, NON-DOWNLOADABLE PHOTOGRAPHIC, AUDIO, AND VIDEO PRESENTATIONS IN THE FIELDS OF INTER-RELIGIOUS DIALOGUE, CHRISTIANITY, JUDAISM, BIBLICAL PROPHECY AND HISTORY, AND A BIBLICAL UNDERSTANDING OF THE JEWISH PEOPLE (U.S. CLS. 100 AND 101).

FIRST USE 0-0-1995; IN COMMERCE 0-0-1995.
ADA HAN, EXAMINING ATTORNEY

SN 85-369,467. SAAMBAA LLC, SAN DIEGO, CA. FILED 7-12-2011.

saambaa

THE MARK CONSISTS OF STANDARD CHARACTERS WITHOUT CLAIM TO ANY PARTICULAR FONT, STYLE, SIZE, OR COLOR.

FOR INTERNET BASED SOCIAL NETWORKING, INTRODUCTION, AND DATING SERVICES; INTERNET-BASED DATING, SOCIAL INTRODUCTION AND SOCIAL NETWORKING SERVICES; INTERNET-BASED SOCIAL NETWORKING SERVICES; ON-LINE SOCIAL NETWORKING SERVICES; ONLINE SOCIAL NETWORKING SERVICES IN THE FIELD OF GENERAL INTEREST AND EVENT PLANNING (U.S. CLS. 100 AND 101).

FIRST USE 8-9-2010; IN COMMERCE 8-9-2010.
STEVEN JACKSON, EXAMINING ATTORNEY

CLASS 45—(Continued).

SN 85-370,335. GRIFFIN, DAVID, SAN DIEGO, CA. FILED 7-13-2011.

NEXT LAWGROUP

THE MARK CONSISTS OF STANDARD CHARACTERS WITHOUT CLAIM TO ANY PARTICULAR FONT, STYLE, SIZE, OR COLOR.

NO CLAIM IS MADE TO THE EXCLUSIVE RIGHT TO USE "LAW GROUP", APART FROM THE MARK AS SHOWN.

FOR LEGAL SERVICES (U.S. CLS. 100 AND 101).
MICHAEL KEATING, EXAMINING ATTORNEY

SN 85-372,262. NOLAND, RORY, SCHAUMBURG, IL. FILED 7-15-2011.

Heart of the Artist

THE MARK CONSISTS OF STANDARD CHARACTERS WITHOUT CLAIM TO ANY PARTICULAR FONT, STYLE, SIZE, OR COLOR.

FOR RELIGIOUS AND SPIRITUAL SERVICES, NAMELY, PROVIDING GATHERINGS AND RETREATS TO DEVELOP AND ENHANCE THE SPIRITUAL LIVES OF INDIVIDUALS; PERSONAL GROWTH AND MOTIVATION CONSULTING SERVICES; PERSONAL LIFESTYLE CONSULTING SERVICES (U.S. CLS. 100 AND 101).

FIRST USE 9-1-2001; IN COMMERCE 10-8-2004.
EDWARD FENNESSY, EXAMINING ATTORNEY

SN 85-380,747. PAUL HASTINGS LLP, LOS ANGELES, CA. FILED 7-26-2011.

PAUL

HASTINGS

OWNER OF U.S. REG. NOS. 2,626,356 AND 2,629,236.
THE NAME(S), PORTRAIT(S), AND/OR SIGNATURE(S) SHOWN IN THE MARK DOES NOT IDENTIFY A PARTICULAR LIVING INDIVIDUAL.

THE COLOR(S) RED, GRAY AND BLACK IS/ARE CLAIMED AS A FEATURE OF THE MARK.

THE MARK CONSISTS OF THE WORDS "PAUL HASTINGS" WITH A HORIZONTAL LINE DIVIDING THE TWO WORDS. THE WORD "PAUL" IS IN RED, THE DIVIDING LINE IS IN BLACK AND THE WORD "HASTINGS" IS IN GRAY.

FOR LEGAL SERVICES (U.S. CLS. 100 AND 101).
FIRST USE 7-25-2011; IN COMMERCE 7-25-2011.
STEVEN R. FINE, EXAMINING ATTORNEY

CLASS 45—(Continued).

SN 85-381,218. PAUL HASTINGS LLP, LOS ANGELES, CA. FILED 7-26-2011.

**PAUL
HASTINGS**

OWNER OF U.S. REG. NOS. 2,626,356 AND 2,629,236. THE NAME(S), PORTRAIT(S), AND/OR SIGNATURE(S) SHOWN IN THE MARK DOES NOT IDENTIFY A PARTICULAR LIVING INDIVIDUAL.

THE MARK CONSISTS OF THE WORDS "PAUL HASTINGS" WITH A HORIZONTAL LINE DIVIDING THE TWO WORDS.

FOR LEGAL SERVICES (U.S. CLS. 100 AND 101). FIRST USE 7-25-2011; IN COMMERCE 7-25-2011. STEVEN R. FINE, EXAMINING ATTORNEY

SN 85-400,079. AHMADIYYA MOVEMENT IN ISLAM, INC., SILVER SPRING, MD. FILED 8-17-2011.

MUSLIMS FOR LIFE

THE MARK CONSISTS OF STANDARD CHARACTERS WITHOUT CLAIM TO ANY PARTICULAR FONT, STYLE, SIZE, OR COLOR.

FOR PROVIDING INFORMATION REGARDING RELIGION, NAMELY, INFORMATION REGARDING THE ISLAMIC FAITH (U.S. CLS. 100 AND 101).

FIRST USE 5-1-2011; IN COMMERCE 5-1-2011. BENJAMIN OKEKE, EXAMINING ATTORNEY

SN 85-401,363. BILLABOUT LLC, NEW YORK, NY. FILED 8-18-2011.

BILLABOUT

THE MARK CONSISTS OF STANDARD CHARACTERS WITHOUT CLAIM TO ANY PARTICULAR FONT, STYLE, SIZE, OR COLOR.

OWNER OF U.S. REG. NO. 4,052,267. FOR ENTERTAINMENT SERVICES, NAMELY, PROVIDING A WEBSITE FEATURING INFORMATION ON CULTURES FROM AROUND THE WORLD AND THE PEOPLE WHO COMPRISE THESE CULTURES (U.S. CLS. 100 AND 101).

FIRST USE 1-26-2011; IN COMMERCE 1-26-2011. SANJEEV VOHRA, EXAMINING ATTORNEY

CLASS 45—(Continued).

SN 85-418,134. VANTRUMP, MICHAEL, JUPITER, FL. FILED 9-8-2011.

BATTLEFIELD GAMERS

THE MARK CONSISTS OF STANDARD CHARACTERS WITHOUT CLAIM TO ANY PARTICULAR FONT, STYLE, SIZE, OR COLOR.

NO CLAIM IS MADE TO THE EXCLUSIVE RIGHT TO USE "GAMERS", APART FROM THE MARK AS SHOWN.

FOR ONLINE SOCIAL NETWORKING SERVICES PROVIDED THROUGH A GAMING COMMUNITY WEBSITE (U.S. CLS. 100 AND 101).

MARIA-VICTORIA SUAREZ, EXAMINING ATTORNEY

SN 85-429,716. ANNE ZUELKE, SAN FRANCISCO, CA. AND SHANE DYKHUIS, SAN FRANCISCO, CA. FILED 9-22-2011.

FOOD MECHANIC

THE MARK CONSISTS OF STANDARD CHARACTERS WITHOUT CLAIM TO ANY PARTICULAR FONT, STYLE, SIZE, OR COLOR.

NO CLAIM IS MADE TO THE EXCLUSIVE RIGHT TO USE "FOOD", APART FROM THE MARK AS SHOWN.

FOR PERSONAL CHEF SERVICES (U.S. CLS. 100 AND 101).

KELLY BOULTON, EXAMINING ATTORNEY

SN 85-438,313. BELLISTRI, CHRISTOPHER, DOUGLSTON, NY. FILED 10-4-2011.

Copstat
SECURITY

NO CLAIM IS MADE TO THE EXCLUSIVE RIGHT TO USE "SECURITY", APART FROM THE MARK AS SHOWN.

THE MARK CONSISTS OF THE WORD "COPSTAT" WRITTEN IN STYLIZED FONT, WHEREIN THE LETTER "O" FILLED FROM INSIDE HAVING AN IMAGE WHICH SEEMS AS AN ECG HEART LINES, AND BELOW THIS WORD AT THE LOWER RIGHT SIDE THE WORD "SECURITY" IS WRITTEN AS SHOWN IN THE MARK.

FOR BODYGUARD SERVICES; SECURITY CONSULTANCY; ALARM RESPONSE AND VERIFICATION SERVICES; SURVEILLANCE SERVICES; PRIVATE INVESTIGATION SERVICES (U.S. CLS. 100 AND 101).

ELLEN BURNS, EXAMINING ATTORNEY

CLASS 45—(Continued).

SN 85-438,519. ATRIUM CHURCH, COLLINSVILLE, IL.
FILED 10-4-2011.

Atrium Church

THE MARK CONSISTS OF STANDARD CHARACTERS WITHOUT CLAIM TO ANY PARTICULAR FONT, STYLE, SIZE, OR COLOR.

NO CLAIM IS MADE TO THE EXCLUSIVE RIGHT TO USE "CHURCH", APART FROM THE MARK AS SHOWN.

FOR EVANGELISTIC AND MINISTERIAL SERVICES (U.S. CLS. 100 AND 101).

KATHLEEN KOLACZ, EXAMINING ATTORNEY

SN 85-442,652. WEIDNER RESORT DEVELOPMENT, INC.,
LAS VEGAS, NV. FILED 10-7-2011.



THE MARK CONSISTS OF A RENDERING OF A PAGODA WITH CHINESE CHARACTERS TO THE RIGHT AND THE WORDS "XING GONG TRAVELING PALACE" BELOW THE RENDERING, WITH A HORIZONTAL LINE BETWEEN THE PAGODA AND THE WORDING.

THE ENGLISH TRANSLATION OF "XING GONG" IN THE MARK IS "TRAVELING PALACE".

THE NON-LATIN CHARACTERS IN THE MARK TRANSLITERATE TO "XING GONG" AND THIS MEANS "TRAVELING PALACE" IN ENGLISH.

FOR WEDDING CHAPEL SERVICES; HOTEL CONCIERGE SERVICES (U.S. CLS. 100 AND 101).

ROBIN MITTLER, EXAMINING ATTORNEY

SN 85-444,152. DRAGO PROTECTIVE SERVICES, LLC,
NAPLES, FL. FILED 10-11-2011.



Drago Protective Services, LLC
Global Security Management

It Is In Our Actions That Ethics, Integrity, And Professionalism Become Visible.

NO CLAIM IS MADE TO THE EXCLUSIVE RIGHT TO USE "PROTECTIVE SERVICES, LLC" OR "GLOBAL SECURITY MANAGEMENT", APART FROM THE MARK AS SHOWN.

THE MARK CONSISTS OF A CIRCULAR CREST WITH

CLASS 45—(Continued).

TWO DRAGONS FACING EACH HOLDING A COIN WITH A "D" IN THE CENTER. ABOVE THE DRAGONS IS A CROWN, AND BELOW THE DRAGONS ARE A LEAF, SCROLL WORK, AND A BANNER. ON THE RIGHT OF THE DESIGN IS THE STYLIZED UNDERLINED WORDING "DRAGO PROTECTIVE SERVICES, LLC" ABOVE THE STYLIZED WORDING "GLOBAL SECURITY MANAGEMENT" AND THE STYLIZED WORDING "IT IS IN OUR ACTIONS THAT ETHICS, INTEGRITY, AND PROFESSIONALISM BECOME VISIBLE."

THE ENGLISH TRANSLATION OF "DRAGO" IS DRAGON.

FOR ADVISORY SERVICES IN THE FIELD OF HOME SECURITY SYSTEMS; AIRLINE PASSENGER SECURITY SCREENING SERVICES; AIRPORT BAGGAGE SECURITY INSPECTION SERVICES; ASSISTING IN THE LOCATING OF CHILDREN FOR SECURITY AND SAFETY PURPOSES USING A GLOBAL POSITIONING SYSTEM; BAGGAGE INSPECTION SERVICES FOR SECURITY PURPOSES; BAGGAGE SECURITY INSPECTIONS FOR AIRLINES; COMPILING INVENTORIES OF PERSONAL ITEMS FOR OTHERS FOR INSURANCE OR SECURITY PURPOSES; COMPUTER SECURITY SERVICES IN THE NATURE OF PROVIDING AN INTERNET TRUST CENTER, NAMELY, COMPUTER SECURITY; ASSURANCE AND ADMINISTRATION OF DIGITAL KEYS AND DIGITAL CERTIFICATES; COMPUTERIZED SECURITY SERVICES, NAMELY, ELECTRONICALLY MONITORING, DETECTING AND REPORTING ON SUSPICIOUS AND ABNORMAL PATTERNS OF POINT OF SALE ACTIVITY WHICH TYPICALLY INDICATE PROBLEMS SUCH AS THEFT, WRONGDOING, TRAINING ISSUES, OR CUSTOMER SERVICE ISSUES; CONSULTANCY SERVICES IN THE FIELD OF HOME SECURITY; CONSULTATION SERVICES CONCERNING HOMELAND SAFETY AND SECURITY ISSUES; CONSULTING AND LEGAL SERVICES IN THE FIELD OF PRIVACY AND SECURITY LAWS, REGULATIONS, AND REQUIREMENTS; CONSULTING SERVICES IN THE FIELD OF MAINTAINING THE SECURITY AND INTEGRITY OF DATABASES; CONSULTING SERVICES IN THE FIELD OF NATIONAL SECURITY; CONSULTING SERVICES IN THE FIELD OF HOMELAND SECURITY; CONTROL OF BUILDING ENVIRONMENTAL ACCESS AND SECURITY SYSTEMS; DRUG, ALCOHOL AND DNA SCREENING FOR SECURITY AND EMPLOYMENT PURPOSES; ELECTRONIC MONITORING SERVICES FOR SECURITY PURPOSES IN THE FIELD OF PERSONS, PROPERTY, VALUABLES; ELECTRONIC SIGNATURE VERIFICATION SERVICES PROVIDED IN CONNECTION WITH CITIZENS PETITIONS, INITIATIVES, RECALLS AND REFERENDA FOR SECURITY PURPOSES; EMERGENCY RESPONSE ALARM MONITORING SERVICES, NAMELY, MONITORING OF ALERT DEVICES BY A REMOTE MONITORING CENTER FOR THE DISPATCH OF EMERGENCY PUBLIC HEALTH AND SECURITY SERVICES AND NOTIFICATION TO THIRD PARTIES; HOME SECURITY MONITORING USING WIRELESS AND WIRED SENSORS FOR GLASS BREAKAGE, MOTION DETECTORS, CAMERAS, POOL ALARMS, WATER ALARMS AND SHUTOFF VALVES, GATE, DOOR AND WINDOW CONTACT SENSORS, SEVERE WEATHER ALARMS; INVESTIGATION OF ASSETS, CREDIT REPORTS, FISCAL ASSESSMENTS, AND COLLECTION REPORTS FOR SECURITY OR AUTHENTICATION PURPOSES; LEASING OF ELECTRONIC TRACKING DEVICES FOR USE IN CONNECTION WITH HOMELAND SECURITY; MAKING PET IDENTIFICATION TAGS AVAILABLE TO OTHERS FOR SECURITY OR LOCATION PURPOSES; MONITORING BURGLAR AND SECURITY ALARMS; MONITORING OF COMPUTER SYSTEMS FOR SECURITY PURPOSES; MONITORING OF SECURITY SYSTEMS; MONITORING OF SECURITY SYSTEMS USED IN ELECTRONIC TRACKING FOR USE IN CONNECTION WITH HOMELAND SECURITY; PERSONAL SECURITY CONSULTATION; PROVIDING A WEB SITE FEATURING INFORMATION IN THE FIELD OF SECURITY; PROVIDING A WEB SITE FEATURING INFORMATION ON THE DEVELOPMENT OF PRIVACY, SECURITY AND DATA GOVERNANCE LAW; PROVIDING INFORMATION CONCERNING HOMELAND SAFETY AND SECURITY ISSUES; PROVIDING INFORMATION IN THE FIELD OF BUILDING SECURITY VIA THE INTERNET; PROVIDING INFORMATION IN THE FIELD OF PERSONAL PHYSICAL SECURITY; PROVIDING NEWS CONCERNING HOME-

CLASS 45—(Continued).

LAND SAFETY AND SECURITY ISSUES; RENTAL OF SECURITY SURVEILLANCE EQUIPMENT; SECURITY CLEARANCE FOR PREPARATION OF IDENTIFICATION CARDS; SECURITY CONSULTANCY; SECURITY CONTROL OF PERSONS AND LUGGAGE IN AIRPORTS; SECURITY DUE DILIGENCE SERVICES FOR INDIVIDUALS OR BUSINESSES TRAVELING OR OPENING AN OFFICE OVERSEAS, IN THE NATURE OF DETAILED FOREIGN COUNTRY BRIEFINGS, VETTING OF LOCAL PERSONNEL, ESTABLISHING HOST COUNTRY GOVERNMENT CONTACTS, AND PROVIDING INFORMATION ON SUSTAINABLE SECURITY MEASURES OVERSEAS; SECURITY GUARD SERVICES; SECURITY GUARDING FOR FACILITIES; SECURITY INSPECTION SERVICES FOR OTHERS; SECURITY PRINTING, NAMELY, ENCODING IDENTIFICATION INFORMATION ON VALUABLE DOCUMENTS AND PRODUCTS; SECURITY SERVICE, NAMELY, PROVIDING A LIST AND PHOTOGRAPHS OF ALL FURNITURE AND BELONGINGS IN A RESIDENCE AND BUSINESS, AS A RECORD TO THE OWNER OF THE CONTENTS IN THE EVENT OF A DISASTER; SECURITY SERVICES FOR BUILDINGS, NAMELY, PROVIDING PHYSICAL ACCESS TO PROPERTIES VIA A REMOTE CALL-IN LOCKING DEVICE; SECURITY SERVICES FOR INDIVIDUALS AND BUSINESS PERSONS TRAVELING INTERNATIONALLY AND DOMESTICALLY, NAMELY, PROVIDING FOREIGN COUNTRY SECURITY BRIEFINGS, EMBASSY INFORMATION FOR SECURITY PURPOSES AND SECURITY REPORTS; SECURITY SERVICES, NAMELY, WATER VULNERABILITY ASSESSMENT SERVICES; SECURITY SERVICES, NAMELY, SEXUAL OFFENDER REGISTRY AND LOCATOR SERVICE; SECURITY SERVICES, NAMELY, THREAT SIMULATION VULNERABILITY ANALYSIS AND MITIGATION AND EMERGENCY AND CRISIS RESPONSE; SECURITY SERVICES, NAMELY, PROVIDING SECURITY ASSESSMENTS OF PHYSICAL LOCATIONS, INFORMATION SYSTEMS, AND WORKING ENVIRONMENTS; SECURITY SERVICES, NAMELY, PROVIDING EXECUTIVE PROTECTION; SECURITY SERVICES, NAMELY, CONDUCTING RECOVERY OPERATIONS FOR THE RECOVERY OF PROPERTY AND PERSONNEL; SECURITY SERVICES, NAMELY, PROVIDING A WEBSITE NOTIFYING INDIVIDUALS OF A CHANGED STATUS OR CONDITION OF A SENSING DEVICE IN A SECURITY SYSTEM VIA ELECTRONIC MESSAGE ALERTS; SECURITY SERVICES, NAMELY, PROVIDING SECURITY ASSESSMENTS FOR BUSINESSES AND GOVERNMENTAL AGENCIES; VERIFYING AND MONITORING THE SECURITY CREDENTIALS OF EVENT STAFF FOR VARIOUS PRIVATE AND PUBLIC SPORTS OR ENTERTAINMENT EVENT (U.S. CLS. 100 AND 101).

FIRST USE 9-1-2009; IN COMMERCE 9-1-2009.
BRIAN PINO, EXAMINING ATTORNEY

SN 85-444,311. MARGO HUDSON, HOLLYWOOD, CA.
FILED 10-11-2011.

DESTINATION LOVE LIFE

THE MARK CONSISTS OF STANDARD CHARACTERS WITHOUT CLAIM TO ANY PARTICULAR FONT, STYLE, SIZE, OR COLOR.

FOR PROVIDING AN INTERNET WEBSITE FEATURING INFORMATION, RESOURCES, AND CONTENT IN THE FIELDS OF SELF IMPROVEMENT, HEALTH, NUTRITION, LIFESTYLE, SPIRITUALITY, PERSONAL RELATIONSHIPS, PERSONAL GROWTH AND MOTIVATION, SELF-FULFILLMENT, AND FASHION (U.S. CLS. 100 AND 101).

ROBERT C. CLARK JR., EXAMINING ATTORNEY

CLASS 45—(Continued).

SN 85-445,228. THE GRACE TRUST, INC., WINONA LAKE, IN. FILED 10-12-2011.

ENCOMPASS WORLD PARTNERS

THE MARK CONSISTS OF STANDARD CHARACTERS WITHOUT CLAIM TO ANY PARTICULAR FONT, STYLE, SIZE, OR COLOR.

FOR EVANGELISTIC, MINISTERIAL AND MISSIONARY SERVICES; EVANGELISTIC, MINISTERIAL AND MISSIONARY SERVICES, NAMELY, PROVIDING BIBLES AND OTHER CHRISTIAN LITERATURE, AND PRAYER SUPPORT TO MISSIONS AND MISSIONARIES, MOBILIZING AND FACILITATING OF HUMANITARIAN AID, MOBILIZING CHURCHES, CHURCH MEMBERS AND THE PUBLIC TO PROVIDE PRAYER, FINANCIAL, AND OTHER SUPPORT FOR MISSIONS AND MISSIONARIES; PROVIDING A WEBSITE FEATURING INFORMATION AND NEWS IN THE FIELD OF MISSIONARY WORK AND MINISTERING TO THE POOR AND NEEDY; PROVIDING A WEBSITE FEATURING INFORMATION ON PRAYER (U.S. CLS. 100 AND 101).

LEIGH CAROLINE CASE, EXAMINING ATTORNEY

SN 85-446,461. PROJECT GREENBOOK, LLC, DBA THE LEGAL ATLAS, MISSOULA, MT. FILED 10-13-2011.

The Legal Atlas

THE MARK CONSISTS OF STANDARD CHARACTERS WITHOUT CLAIM TO ANY PARTICULAR FONT, STYLE, SIZE, OR COLOR.

NO CLAIM IS MADE TO THE EXCLUSIVE RIGHT TO USE "LEGAL", APART FROM THE MARK AS SHOWN.

FOR LEGAL CONSULTATION SERVICES (U.S. CLS. 100 AND 101).

FRANK LATTUCA, EXAMINING ATTORNEY

SN 85-447,002. BIALYS, MICHAEL K., DBA THE DUI DUDE, CANYON COUNTRY, CA. AND SKALSKY, WADE, AKA LAW OFFICE OF WADE SKALSKY, VALENCIA, CA. FILED 10-13-2011.

Appellate Ink

THE MARK CONSISTS OF STANDARD CHARACTERS WITHOUT CLAIM TO ANY PARTICULAR FONT, STYLE, SIZE, OR COLOR.

NO CLAIM IS MADE TO THE EXCLUSIVE RIGHT TO USE "APPELLATE", APART FROM THE MARK AS SHOWN.

FOR LITIGATION SERVICES (U.S. CLS. 100 AND 101).
MEGHAN REINHART, EXAMINING ATTORNEY

CLASS 45—(Continued).

SN 85-447,466. PHOTOJEANIE, LLC, NEW YORK, NY.
FILED 10-14-2011.

PHOTOJEANIE

THE MARK CONSISTS OF STANDARD CHARACTERS WITHOUT CLAIM TO ANY PARTICULAR FONT, STYLE, SIZE, OR COLOR.

FOR ORGANIZATIONAL SERVICES FOR HOME OR PERSONAL PURPOSES, NAMELY, ORGANIZING PHOTOGRAPHS, SLIDES, NEGATIVES, TEAR SHEETS, AND MEMENTOS; PREPARATION OF CUSTOM MEMORY BOOKS, SCRAPBOOKS, PERSONAL ARCHIVES, FAMILY ARCHIVES, WEDDING ALBUMS, DIARIES, VACATION ALBUMS, FAMILY ALBUMS, FAMILY HISTORIES, PHOTOGRAPH ALBUMS, BIRTHDAY ALBUMS, AND SPECIAL EVENT ALBUMS FOR OTHERS (U.S. CLS. 100 AND 101).

FIRST USE 8-0-2000; IN COMMERCE 8-0-2000.
BRIDGETT SMITH, EXAMINING ATTORNEY

SN 85-447,734. GREEN DOT CORPORATION, MONROVIA, CA. FILED 10-14-2011.

GREEN SCREEN

THE MARK CONSISTS OF STANDARD CHARACTERS WITHOUT CLAIM TO ANY PARTICULAR FONT, STYLE, SIZE, OR COLOR.

FOR FRAUD DETECTION SERVICES IN THE FIELD OF DEBIT AND CREDIT CARD PURCHASES (U.S. CLS. 100 AND 101).

MATTHEW EINSTEIN, EXAMINING ATTORNEY

SN 85-447,923. C-VIBES USA CORP, NEW YORK, NY. FILED 10-14-2011.

CHUMKEE

THE MARK CONSISTS OF STANDARD CHARACTERS WITHOUT CLAIM TO ANY PARTICULAR FONT, STYLE, SIZE, OR COLOR.

FOR INTERNET-BASED SOCIAL NETWORKING SERVICES (U.S. CLS. 100 AND 101).

JOHN DALIER, EXAMINING ATTORNEY

CLASS 45—(Continued).

SN 85-448,256. PHOTOJEANIE, LLC, NEW YORK, NY.
FILED 10-14-2011.

APARTMENTJEANIE

THE MARK CONSISTS OF STANDARD CHARACTERS WITHOUT CLAIM TO ANY PARTICULAR FONT, STYLE, SIZE, OR COLOR.

FOR ORGANIZATIONAL SERVICES FOR HOME OR PERSONAL PURPOSES, NAMELY, ORGANIZING RESIDENCES, RESIDENTIAL LIVING SPACES AND HOME OFFICE SPACES (U.S. CLS. 100 AND 101).

FIRST USE 12-31-2008; IN COMMERCE 12-31-2008.
BRIDGETT SMITH, EXAMINING ATTORNEY

SN 85-448,260. PHOTOJEANIE, LLC, NEW YORK, NY.
FILED 10-14-2011.

CHAOS CONQUEROR

THE MARK CONSISTS OF STANDARD CHARACTERS WITHOUT CLAIM TO ANY PARTICULAR FONT, STYLE, SIZE, OR COLOR.

FOR ORGANIZATIONAL SERVICES FOR HOME OR PERSONAL PURPOSES, NAMELY, ORGANIZING RESIDENCES, RESIDENTIAL LIVING SPACES, AND HOME OFFICE SPACES AND PHOTOGRAPHS, SLIDES, NEGATIVES, TEAR SHEETS, AND MEMENTOS; PREPARATION OF CUSTOM MEMORY BOOKS, SCRAPBOOKS, PERSONAL ARCHIVES, FAMILY ARCHIVES, WEDDING ALBUMS, DIARIES, VACATION ALBUMS, FAMILY ALBUMS, FAMILY HISTORIES, PHOTOGRAPH ALBUMS, BIRTHDAY ALBUMS, AND SPECIAL EVENT ALBUMS FOR OTHERS (U.S. CLS. 100 AND 101).

FIRST USE 6-0-2003; IN COMMERCE 6-0-2003.
BRIDGETT SMITH, EXAMINING ATTORNEY

CLASS 45—(Continued).

SN 85-448,298. PHOTOJEANIE, LLC, NEW YORK, NY.
FILED 10-15-2011.

LIVE BETTER ORGANIZED

THE MARK CONSISTS OF STANDARD CHARACTERS WITHOUT CLAIM TO ANY PARTICULAR FONT, STYLE, SIZE, OR COLOR.

FOR ORGANIZATIONAL SERVICES FOR HOME OR PERSONAL PURPOSES, NAMELY, ORGANIZING RESIDENCES, RESIDENTIAL LIVING SPACES, AND HOME OFFICE SPACES AND PHOTOGRAPHS, SLIDES, NEGATIVES, TEAR SHEETS, AND MEMENTOS; PREPARATION OF CUSTOM MEMORY BOOKS, SCRAPBOOKS, PERSONAL ARCHIVES, FAMILY ARCHIVES, WEDDING ALBUMS, DIARIES, VACATION ALBUMS, FAMILY ALBUMS, FAMILY HISTORIES, PHOTOGRAPH ALBUMS, BIRTHDAY ALBUMS, AND SPECIAL EVENT ALBUMS FOR OTHERS (U.S. CLS. 100 AND 101).

FIRST USE 12-31-2008; IN COMMERCE 12-31-2010.
BRIDGETT SMITH, EXAMINING ATTORNEY

SN 85-448,990. THE PLANNING AND ZONING RESOURCE CORPORATION, AKA PZR, OKLAHOMA CITY, OK.
FILED 10-17-2011.

PZR

THE MARK CONSISTS OF STANDARD CHARACTERS WITHOUT CLAIM TO ANY PARTICULAR FONT, STYLE, SIZE, OR COLOR.

OWNER OF U.S. REG. NO. 3,507,345.
FOR PERMITTING, NAMELY, OBTAINING ENVIRONMENTAL, DESIGN, ZONING AND OTHER GOVERNMENTAL PERMITS FOR DEVELOPMENT PROJECTS; REVIEWING STANDARDS AND PRACTICES TO ASSURE COMPLIANCE WITH ZONING LAWS AND REGULATIONS (U.S. CLS. 100 AND 101).
JASON BLAIR, EXAMINING ATTORNEY

SN 85-449,120. ENTOURAGEME LLC, WILMINGTON, DE.
FILED 10-17-2011.

ENTOURAGEME

THE MARK CONSISTS OF STANDARD CHARACTERS WITHOUT CLAIM TO ANY PARTICULAR FONT, STYLE, SIZE, OR COLOR.

FOR INTERNET-BASED SOCIAL NETWORKING SERVICES; ON-LINE SOCIAL NETWORKING SERVICES (U.S. CLS. 100 AND 101).
ALEX KEAM, EXAMINING ATTORNEY

CLASS 45—(Continued).

SN 85-449,250. CROSSWILD MINISTRIES INC., TALLAHASSEE, FL. FILED 10-17-2011.



THE MARK CONSISTS OF THE WORDS "CROSS WILD" WITH THE "C", "R", SECOND "S", "W", "I", "L", AND "D" ALL CAPITALIZED, AND A CROSS BETWEEN THE WORDS.

FOR CHRISTIAN MINISTRY SERVICES (U.S. CLS. 100 AND 101).

FIRST USE 2-25-2008; IN COMMERCE 2-25-2008.
JOHN WILKE, EXAMINING ATTORNEY

SN 85-449,441. WADE II, DAVID EUGENE, LAWRENCEVILLE, GA. FILED 10-18-2011.

Self Made Protege

THE MARK CONSISTS OF STANDARD CHARACTERS WITHOUT CLAIM TO ANY PARTICULAR FONT, STYLE, SIZE, OR COLOR.

FOR PROVIDING A MOTIVATIONAL WEBSITE THE PRIMARY MISSION OF WHICH IS TO INCREASE PERSONAL HAPPINESS IN TERMS OF PERSONAL RELATIONSHIPS, PERSONAL GROWTH AND MOTIVATION, AND SELF-FULFILLMENT (U.S. CLS. 100 AND 101).

SETH A. RAPPAPORT, EXAMINING ATTORNEY

SN 85-449,583. THE MATCHBOOK LLC, BROOKLYN, NY.
FILED 10-18-2011.

MATCHBOOK

THE MARK CONSISTS OF STANDARD CHARACTERS WITHOUT CLAIM TO ANY PARTICULAR FONT, STYLE, SIZE, OR COLOR.

FOR MATCHMAKING SERVICES (U.S. CLS. 100 AND 101).

FIRST USE 7-1-2010; IN COMMERCE 7-1-2010.
TINA BROWN, EXAMINING ATTORNEY

CLASS 45—(Continued).

SN 85-449,714. FARAH & FARAH, P.A., JACKSONVILLE, FL.
FILED 10-18-2011.

****5555**

THE MARK CONSISTS OF STANDARD CHARACTERS WITHOUT CLAIM TO ANY PARTICULAR FONT, STYLE, SIZE, OR COLOR.

FOR TELEPHONE HOT LINE COUNSELING, NAMELY OFFERING ADVICE RELATING TO ACCIDENT INVESTIGATIONS, LEGAL SERVICES, AND INVESTIGATION SERVICES RELATED TO INSURANCE CLAIMS WITH REGARD TO AUTO ACCIDENTS, INCLUDING PERSONAL INJURIES RESULTING FROM AUTO ACCIDENTS (U.S. CLS. 100 AND 101).
TRACY FLETCHER, EXAMINING ATTORNEY

SN 85-449,851. KITHE BREWSTER INC, NEW YORK, NY.
FILED 10-18-2011.

KITHE BREWSTER

THE MARK CONSISTS OF STANDARD CHARACTERS WITHOUT CLAIM TO ANY PARTICULAR FONT, STYLE, SIZE, OR COLOR.

THE NAME(S), PORTRAIT(S), AND/OR SIGNATURE(S) SHOWN IN THE MARK IDENTIFIES KITHE BREWSTER, WHOSE CONSENT(S) TO REGISTER IS MADE OF RECORD.

FOR FASHION TREND CONSULTING FOR THE FASHION INDUSTRY; PERSONAL STYLIST SERVICES, NAMELY, EVALUATING THE PHYSICAL ATTRIBUTES, LIFESTYLE, AND FASHION STYLES OF OTHERS AND RECOMMENDING CLOTHING AND ACCESSORIES TO ACHIEVE THE PERSONAL IMAGE DESIRED BY THE CLIENT (U.S. CLS. 100 AND 101).
FIRST USE 5-15-1989; IN COMMERCE 5-15-1989.
SHAILA SETTLES, EXAMINING ATTORNEY

CLASS 45—(Continued).

SN 85-451,216. TEMPLE OF DIANA, INC., HOLLANDALE, WI. FILED 10-19-2011.



THE NAME(S), PORTRAIT(S), AND/OR SIGNATURE(S) SHOWN IN THE MARK DOES NOT IDENTIFY A PARTICULAR LIVING INDIVIDUAL.

THE MARK CONSISTS OF A SILHOUETTE IMAGE OF A WOMAN WITH A BOW AND ARROW. THERE IS A CIRCLE SURROUNDING THE WOMAN.

FOR CONDUCTING RELIGIOUS PRAYER SERVICES; RELIGIOUS AND SPIRITUAL SERVICES, NAMELY, PROVIDING GATHERINGS AND RETREATS TO DEVELOP AND ENHANCE THE SPIRITUAL LIVES OF INDIVIDUALS; RELIGIOUS SERVICES, NAMELY, PRAYER MEETINGS (U.S. CLS. 100 AND 101).
FIRST USE 0-0-2001; IN COMMERCE 0-0-2001.

JORDAN BAKER, EXAMINING ATTORNEY

SN 85-457,403. NASH, DAVID RICHARD, EASTRIGGS, UNITED KINGDOM, AND EVANS, NEIL ANDREW, STAMFORD, UNITED KINGDOM, FILED 10-27-2011.

GROWLR

THE MARK CONSISTS OF STANDARD CHARACTERS WITHOUT CLAIM TO ANY PARTICULAR FONT, STYLE, SIZE, OR COLOR.

THE WORDING "GROWLR" HAS NO MEANING IN A FOREIGN LANGUAGE.

FOR INTERNET BASED SOCIAL NETWORKING, INTRODUCTION, AND DATING SERVICES (U.S. CLS. 100 AND 101).
FIRST USE 2-19-2010; IN COMMERCE 2-19-2010.

RUSS HERMAN, EXAMINING ATTORNEY

CLASS 45—(Continued).

SN 85-458,775. HYPERTEXT INDEX TRACKING SYSTEMS,
L.L.C., SAN ANTONIO, TX. FILED 10-28-2011.

EASY LAW LOOKUP

THE MARK CONSISTS OF STANDARD CHARACTERS
WITHOUT CLAIM TO ANY PARTICULAR FONT, STYLE,
SIZE, OR COLOR.

NO CLAIM IS MADE TO THE EXCLUSIVE RIGHT TO
USE "LAW LOOKUP", APART FROM THE MARK AS
SHOWN.

FOR PROVIDING A WEBSITE FEATURING LAWS OF
PARTICULAR JURISDICTIONS (U.S. CLS. 100 AND 101).
FIRST USE 3-25-2011; IN COMMERCE 3-25-2011.
KEVON CHISOLM, EXAMINING ATTORNEY

* * * * *

SECTION 4.—PRIOR UNITED STATES CLASSIFICATION

APPLICATION IN ONE CLASS

COLLECTIVE MEMBERSHIP MARKS

CLASS 200—COLLECTIVE MEMBERSHIP
SN 85-234,037. LLAMAS, GILBERT, OXNARD, CA. FILED 2-4-2011.



NO CLAIM IS MADE TO THE EXCLUSIVE RIGHT TO USE "MC", APART FROM THE MARK AS SHOWN.

THE MARK CONSISTS OF A SHIELD CONTAINING THE WORD "VICLEROS", A SKULL WEARING A HAT, MOTORCYCLE HANDLE BARS, AND HAND BONES; A RECTANGLE CONTAINING THE LETTERS "MC"; AND A BANNER CONTAINING THE WORD "CHIQUES".

THE WORDING IN THE MARK HAS NO MEANING IN A FOREIGN LANGUAGE.

FOR INDICATING MEMBERSHIP IN A SOCIAL CLUB.

FIRST USE 10-0-2010; IN COMMERCE 10-0-2010.
DAVID C. REIHNER, EXAMINING ATTORNEY

THE MARK CONSISTS OF EIGHT TRIANGLES ARRANGED BY DECREASING SIZE, FORMING A SEMICIRCLE WITH AN OFF-CENTER RADIAL POINT, WITH THE TOP TRIANGLE IN TURQUOISE, THEN RED, BROWN, PURPLE, BLUE, DARK GRAY, GOLD AND THE LAST ONE IN ORANGE. TO THE RIGHT IS THE WORDING "MEMBER" IN BLUE "NETWORK OF EXECUTIVE WOMEN" IN BLACK AND BELOW "CONSUMER PRODUCTS/RETAIL" IS LIGHT GRAY.

SEC. 2(F) AS TO "NETWORK OF EXECUTIVE WOMEN".
FOR INDICATING MEMBERSHIP IN AN ORGANIZATION OF WOMEN WHO WORK IN THE FOOD, BEVERAGE, CONSUMER PRODUCTS AND/OR RETAIL INDUSTRIES.

ALICE BENMAMAN, EXAMINING ATTORNEY

SN 85-241,487. NETWORK OF EXECUTIVE WOMEN, INC.,
CHICAGO, IL. FILED 2-14-2011.



SN 85-241,410. NETWORK OF EXECUTIVE WOMEN, INC.,
CHICAGO, IL. FILED 2-14-2011.



NO CLAIM IS MADE TO THE EXCLUSIVE RIGHT TO USE "MEMBER" AND "CONSUMER PRODUCTS/RETAIL", APART FROM THE MARK AS SHOWN.

THE COLOR(S) TURQUOISE, RED, BROWN, PURPLE, BLUE, DARK GRAY, GOLD, ORANGE, AND LIGHT GRAY, AND BLACK IS/ARE CLAIMED AS A FEATURE OF THE MARK.

NO CLAIM IS MADE TO THE EXCLUSIVE RIGHT TO USE "REGIONAL GROUP", APART FROM THE MARK AS SHOWN.

THE COLOR(S) TURQUOISE, RED, BROWN, PURPLE, BLUE, DARK GRAY, GOLD, ORANGE, LIGHT GRAY AND BLACK ARE CLAIMED AS A FEATURE OF THE MARK IS/ARE CLAIMED AS A FEATURE OF THE MARK.

THE MARK CONSISTS OF EIGHT TRIANGLES ARRANGED BY DECREASING SIZE, FORMING A SEMICIRCLE WITH AN OFF-CENTER RADIAL POINT, WITH THE TOP TRIANGLE IN TURQUOISE, THEN RED, BROWN, PURPLE, BLUE, DARK GRAY, GOLD AND THE LAST ONE IN ORANGE. TO THE RIGHT IS THE WORDING "NETWORK OF EXECUTIVE WOMEN" IN BLACK AND BELOW "REGIONAL GROUP" IN LIGHT GRAY.

SEC. 2(F) AS TO "NETWORK OF EXECUTIVE WOMEN".
FOR INDICATING MEMBERSHIP IN THE NATURE OF REGIONAL GROUP MEMBERSHIP IN AN ORGANIZATION OF WOMEN WHO WORK IN THE FOOD, BEVERAGE, CONSUMER PRODUCTS AND/OR RETAIL INDUSTRIES.

ALICE BENMAMAN, EXAMINING ATTORNEY

MARCH 27, 2012

U.S. PATENT AND TRADEMARK OFFICE

TM 1047

SN 85-357,555. THE FREecycle NETWORK, TUCSON, AZ.
FILED 6-27-2011.

SN 85-450,173. CHAILLET, MARK, DBA INTERNATIONAL
POWERLIFTING ASSOCIATION, YORK, PA. FILED 10-
18-2011.



THE MARK CONSISTS OF THE TERM "FREecycle-
CLE.ORG" WITH A CURVED ARROW BELOW THE TERM
AND A CURVED ARROW HAVING FIVE DROPLET-LIKE
DESIGNS RADIATING THEREFROM ABOVE THE TERM.
FOR INDICATING MEMBERSHIP IN AN ORGANIZA-
TION THAT PROMOTES THE RE-USE OF UNWANTED
ITEMS.

JULIE GUTTADAURO, EXAMINING ATTORNEY

INTERNATIONAL POWERLIFTING
ASSOCIATION

THE MARK CONSISTS OF STANDARD CHARACTERS
WITHOUT CLAIM TO ANY PARTICULAR FONT, STYLE,
SIZE, OR COLOR.

NO CLAIM IS MADE TO THE EXCLUSIVE RIGHT TO
USE "ASSOCIATION", APART FROM THE MARK AS
SHOWN.

SEC. 2(F).

FOR INDICATING MEMBERSHIP IN AN ASSOCIA-
TION OF INDIVIDUALS WHO ARE INVOLVED IN THE
SPORT OF POWERLIFTING, WHO PRESENT POWER-
LIFTING MEETS, AND WHO SANCTION OTHERS PRE-
SENTING SUCH MEETS.

FIRST USE 0-0-1993; IN COMMERCE 0-0-1993.

REBECCA POVARCHUK, EXAMINING ATTORNEY

SN 85-379,840. GREATER MIAMI JEWISH FEDERATION,
INC., MIAMI, FL. FILED 7-25-2011.

SN 85-464,164. THE CHOSEN ONES MOTORCYCLE CLUB,
GRAND JUNCTION, CO. FILED 11-3-2011.



The Chosen Ones Motorcycle
Club

THE MARK CONSISTS OF STANDARD CHARACTERS
WITHOUT CLAIM TO ANY PARTICULAR FONT, STYLE,
SIZE, OR COLOR.

NO CLAIM IS MADE TO THE EXCLUSIVE RIGHT TO
USE "MOTORCYCLE CLUB", APART FROM THE MARK
AS SHOWN.

FOR INDICATING MEMBERSHIP IN A MOTOR-
CYCLE CLUB.

ADA HAN, EXAMINING ATTORNEY

THE STIPLING IS FOR SHADING PURPOSES ONLY.
THE MARK CONSISTS OF A STYLIZED LION DESIGN,
WITH A JEWELLED EYE AND CIRCULAR DESIGNS ON
EACH PAW AND THE TAIL, WITH A JEWISH STAR
DESIGN FORMED BY SIX ARROW-SHAPED ELEMENTS
EXTENDING BELOW THE LEFT FRONT PAW.

FOR INDICATING MEMBERSHIP IN AN ORGANIZA-
TION WHOSE MEMBERS ARE WOMEN WHO HAVE
MADE A CERTAIN LEVEL OF CHARITABLE CONTRI-
BUTIONS TO JEWISH FEDERATION CAUSES.

FIRST USE 12-31-1972; IN COMMERCE 12-31-1972.

WILLIAM JACKSON, EXAMINING ATTORNEY

CERTIFICATION MARKS

CLASS B—SERVICES

SN 76-708,690. HUMAN RESOURCE CERTIFICATION INSTITUTE, ALEXANDRIA, VA. FILED 8-10-2011.

SN 85-374,097. THE ASSOCIATION OF POOL AND SPA PROFESSIONALS, ALEXANDRIA, VA. FILED 7-18-2011.



NO CLAIM IS MADE TO THE EXCLUSIVE RIGHT TO USE "HR", APART FROM THE MARK AS SHOWN.

THE MARK CONSISTS OF A CIRCLE. THE LEFT SIDE OF THE CIRCLE APPEARS LIGHTER THAN THE RIGHT SIDE OF THE CIRCLE. INSIDE THE CIRCLE APPEARS THE LETTERS "HRBP" IN A STYLIZED FORMAT. THE LETTERS "HR" APPEAR SMALLER THAN THE LETTERS "BP".

THE CERTIFICATION MARK, AS INTENDED TO BE USED BY AUTHORIZED PERSONS, IS INTENDED TO CERTIFY THAT AUTHORIZED INDIVIDUALS COMPLETED THE NECESSARY EDUCATIONAL REQUIREMENTS TO BECOME A CERTIFIED HUMAN RESOURCES PROFESSIONAL.

FOR HUMAN RESOURCE MANAGEMENT,
MAYUR VAGHANI, EXAMINING ATTORNEY

SN 85-018,827. WATCHDOG CITY LLC, NAPLES, FL. FILED 4-20-2010.

Watchdog City Blogger

THE MARK CONSISTS OF STANDARD CHARACTERS WITHOUT CLAIM TO ANY PARTICULAR FONT, STYLE, SIZE, OR COLOR.

NO CLAIM IS MADE TO THE EXCLUSIVE RIGHT TO USE "BLOGGER", APART FROM THE MARK AS SHOWN.

THE CERTIFICATION MARK, AS INTENDED TO BE USED BY AUTHORIZED PERSONS, IS INTENDED TO CERTIFY THAT A PERSON HAS SATISFIED THE INITIAL AND/OR ONGOING QUALIFICATIONS AND QUALITY STANDARDS OF THE CERTIFIER REGARDING THE PERSON'S WRITTEN, AUDIO AND VISUAL WORKS.

FOR ONLINE JOURNAL AND COMMENTARY WRITING, NAMELY, WRITING BLOGS IN THE FIELD OF WRITTEN, AUDIO AND VISUAL WORKS,
BENJAMIN OKEKE, EXAMINING ATTORNEY

CST CERTIFIED SERVICE TECHNICIAN

THE MARK CONSISTS OF STANDARD CHARACTERS WITHOUT CLAIM TO ANY PARTICULAR FONT, STYLE, SIZE, OR COLOR.

OWNER OF U.S. REG. NOS. 2,236,102 AND 2,237,421.

NO CLAIM IS MADE TO THE EXCLUSIVE RIGHT TO USE "CERTIFIED SERVICE TECHNICIAN", APART FROM THE MARK AS SHOWN.

THE CERTIFICATION MARK, AS INTENDED TO BE USED BY AUTHORIZED PERSONS, IS INTENDED TO CERTIFY THAT THE PERSONS USING THE MARK HAVE MET, THROUGH A TRAINING AND TESTING PROGRAM, CERTAIN QUALIFICATIONS TO SERVICE AND REPAIR POOL AND SPA SYSTEMS AND EQUIPMENT.

FOR SERVICE AND REPAIR OF POOL AND SPA SYSTEMS AND EQUIPMENT.

DORITT L. CARROLL, EXAMINING ATTORNEY

SN 85-444,306. ARIZONA EDUCATIONAL FOUNDATION, INC., SCOTTSDALE, AZ. FILED 10-11-2011.

A+ SCHOOL OF EXCELLENCE

THE MARK CONSISTS OF STANDARD CHARACTERS WITHOUT CLAIM TO ANY PARTICULAR FONT, STYLE, SIZE, OR COLOR.

NO CLAIM IS MADE TO THE EXCLUSIVE RIGHT TO USE "SCHOOL OF EXCELLENCE", APART FROM THE MARK AS SHOWN.

THE CERTIFICATION MARK, AS USED BY AUTHORIZED PERSONS, CERTIFIES THAT THE RECIPIENTS HAVE A STRONG COMMITMENT TO ACADEMIC EXCELLENCE, MEET RIGOROUS TEACHING AND LEARNING STANDARDS, DEMONSTRATE STRONG STUDENT ACHIEVEMENT RESULTS, CULTIVATE LEARNING-CENTERED SCHOOL ENVIRONMENTS, ARE SUPPORTIVE OF THE SOCIAL, EMOTIONAL, PHYSICAL, AND INTELLECTUAL NEEDS OF THE WHOLE CHILD, FOCUS ON THE INDIVIDUAL NEEDS OF EVERY CHILD AND HAVE DEMONSTRATED A SUPERIOR ABILITY TO GO ABOVE AND BEYOND THE NORM IN PROVIDING EDUCATIONAL SERVICES TO CHILDREN, FAMILIES, AND THE LOCAL COMMUNITY.

FOR EDUCATION SERVICES, NAMELY, PROVIDING PRE-KINDERGARTEN THROUGH 12TH GRADE CLASSROOM INSTRUCTION .

FIRST USE 4-20-2011; IN COMMERCE 4-20-2011.
KAREN K. BUSH, EXAMINING ATTORNEY

TRADEMARK REGISTRATIONS ISSUED

PRINCIPAL REGISTER

SECTION 1.— INTERNATIONAL CLASSIFICATION

The short titles associated below with the international class numbers are terms designed merely for quick identification and are not an official part of the international classification. The full names of international classes are given in section 6.1 of the trademark rules of practice.

The designation "U.S. Cl." appearing in this section refers to the U.S. class in effect prior to Sep. 1, 1973 rather than the international class which applies to applications filed on or after that date. For adoption of international classification see notice in the OFFICIAL GAZETTE of Jun. 26, 1973 (911 O.G. TM 210).

CLASS 1—CHEMICALS

- 4,116,562. **TRUE SOURCE ORGANIC (STANDARD CHARACTER)**, FERTRELL, (U.S. CLS. 1, 5, 6, 10, 26 AND 46). SN 76-704,808. PUB. 1-10-2012. FILED 10-7-2010.
- 4,116,658. **HIGH MILEAGE AND DESIGN. IDQ OPERATING, INC.**, (U.S. CLS. 1, 5, 6, 10, 26 AND 46). SN 77-923,633. PUB. 1-10-2012. FILED 1-29-2010.
- 4,116,670. **ASTEL (STANDARD CHARACTER)**, BHP BILLITON S.A. LIMITED, MULTIPLE CLASS, (INT. CLS. 1, 5 AND 40), (U.S. CLS. 1, 5, 6, 10, 18, 26, 44, 46, 51, 52, 100, 103 AND 106). SN 78-650,091. PUB. 1-10-2012. FILED 6-14-2005.
- 4,116,675. **KITOZYME AND DESIGN. KITOZYME S.A.**, MULTIPLE CLASS, (INT. CLS. 1, 5 AND 42), (U.S. CLS. 1, 5, 6, 10, 18, 26, 44, 46, 51, 52, 100 AND 101). SN 79-040,754. PUB. 1-10-2012. FILED 4-26-2007.
- 4,116,678. **SMS MEER SMS GROUP AND DESIGN. SMS GMBH**, MULTIPLE CLASS, (INT. CLS. 1, 2, 6, 7, 9, 11, 16, 19, 35, 37, 40, 41 AND 42), (U.S. CLS. 1, 2, 5, 6, 10, 11, 12, 13, 14, 16, 19, 21, 22, 23, 25, 26, 29, 31, 33, 34, 35, 36, 37, 38, 46, 50, 100, 101, 102, 103, 106 AND 107). SN 79-073,614. PUB. 1-10-2012. FILED 7-21-2009.
- 4,116,704. **EMERY (STANDARD CHARACTER)**, EMERY OLEOCHEMICALS GMBH, MULTIPLE CLASS, (INT. CLS. 1, 2, 3, 4, 5, 19, 29, 30 AND 31), (U.S. CLS. 1, 4, 5, 6, 10, 11, 12, 15, 16, 18, 26, 33, 44, 46, 50, 51 AND 52). SN 79-086,882. PUB. 1-10-2012. FILED 1-13-2010.
- 4,116,739. **COVA AND DESIGN. GRAPHITE INTERNATIONAL B.V.**, MULTIPLE CLASS, (INT. CLS. 1 AND 9), (U.S. CLS. 1, 5, 6, 10, 21, 23, 26, 36, 38 AND 46). SN 79-094,757. PUB. 1-10-2012. FILED 2-9-2011.
- 4,116,791. **SIPERDISP (STANDARD CHARACTER)**, EVONIK DEGUSSA GMBH, MULTIPLE CLASS, (INT. CLS. 1 AND 3), (U.S. CLS. 1, 4, 5, 6, 10, 26, 46, 50, 51 AND 52). SN 79-097,633. PUB. 1-10-2012. FILED 12-9-2010.
- 4,116,802. **CLEANEFFECT AND DESIGN. STUDIO MODERNA SA**, (U.S. CLS. 1, 5, 6, 10, 26 AND 46). SN 79-098,532. PUB. 1-10-2012. FILED 5-16-2011.
- 4,116,817. **ROYALACTIN (STYLIZED)**, POLA CHEMICAL INDUSTRIES INC., (U.S. CLS. 1, 5, 6, 10, 26 AND 46). SN 79-099,541. PUB. 1-10-2012. FILED 5-23-2011.
- 4,116,828. **SIL-O-SAN (STANDARD CHARACTER)**, SCHILL + SEILACHER GMBH, (U.S. CLS. 1, 5, 6, 10, 26 AND 46). SN 79-100,295. PUB. 1-10-2012. FILED 6-15-2011.
- 4,116,983. **MAZE (STANDARD CHARACTER)**, STRAUSS WATER LTD., MULTIPLE CLASS, (INT. CLS. 1, 11 AND 32), (U.S. CLS. 1, 5, 6, 10, 13, 21, 23, 26, 31, 34, 45, 46 AND 48). SN 85-171,298. PUB. 1-10-2012. FILED 11-8-2010.
- 4,117,084. **ENGINE ENERGY (STANDARD CHARACTER)**, B3C FUEL SOLUTIONS, LLC, (U.S. CLS. 1, 5, 6, 10, 26 AND 46). SN 85-223,235. PUB. 1-10-2012. FILED 1-21-2011.
- 4,117,085. **ENGINE ENERGY AND DESIGN. B3C FUEL SOLUTIONS, LLC**, (U.S. CLS. 1, 5, 6, 10, 26 AND 46). SN 85-223,242. PUB. 1-10-2012. FILED 1-21-2011.
- 4,117,305. **PERMASEAL (STANDARD CHARACTER)**, KCK INTERNATIONAL, INC., DBA PERMASEAL, (U.S. CLS. 1, 5, 6, 10, 26 AND 46). SN 85-261,329. PUB. 1-10-2012. FILED 3-8-2011.
- 4,117,423. **W AND DESIGN. WATSON STANDARD COMPANY**, MULTIPLE CLASS, (INT. CLS. 1, 2 AND 4), (U.S. CLS. 1, 5, 6, 10, 11, 15, 16, 26 AND 46). SN 85-287,908. PUB. 10-4-2011. FILED 4-6-2011.
- 4,117,490. **WALKSAFE FOR PETS AND DESIGN. KNIGHT CHEMICALS, LLC**, (U.S. CLS. 1, 5, 6, 10, 26 AND 46). SN 85-300,383. PUB. 1-10-2012. FILED 4-20-2011.
- 4,117,569. **THE REAL MCCOY ORGANIC COMPOST (STANDARD CHARACTER)**, SOILAND CO., INC., (U.S. CLS. 1, 5, 6, 10, 26 AND 46). SN 85-318,387. PUB. 1-10-2012. FILED 5-11-2011.
- 4,117,571. **SIFCLEAR (STANDARD CHARACTER)**, JSR CORPORATION, MULTIPLE CLASS, (INT. CLS. 1 AND 2), (U.S. CLS. 1, 5, 6, 10, 11, 16, 26 AND 46). SN 85-318,911. PUB. 1-10-2012. FILED 5-12-2011.
- 4,117,778. **CLEAN EARTH SOILS (STANDARD CHARACTER)**, ECO SCRAPS, LLC, (U.S. CLS. 1, 5, 6, 10, 26 AND 46). SN 85-355,490. PUB. 1-10-2012. FILED 6-24-2011.
- 4,117,804. **CHEMISTRY INSPIRED BY NATURE (STANDARD CHARACTER)**, BIOAMBER S.A.S., MULTIPLE CLASS, (INT. CLS. 1 AND 45), (U.S. CLS. 1, 5, 6, 10, 26, 46, 100 AND 101). SN 85-358,983. PUB. 1-10-2012. FILED 6-29-2011.
- 4,117,806. **BIOAMBER CHEMISTRY INSPIRED BY NATURE AND DESIGN. BIOAMBER S.A.S.**, MULTIPLE CLASS, (INT. CLS. 1 AND 45), (U.S. CLS. 1, 5, 6, 10, 26, 46, 100 AND 101). SN 85-359,016. PUB. 1-10-2012. FILED 6-29-2011.
- 4,117,807. **BIOAMBER (STANDARD CHARACTER)**, BIOAMBER S.A.S., MULTIPLE CLASS, (INT. CLS. 1 AND 45), (U.S. CLS. 1, 5, 6, 10, 26, 46, 100 AND 101). SN 85-359,044. PUB. 1-10-2012. FILED 6-29-2011.
- 4,117,813. **ECOSCRAPS (STANDARD CHARACTER)**, ECO SCRAPS, LLC, (U.S. CLS. 1, 5, 6, 10, 26 AND 46). SN 85-359,612. PUB. 1-10-2012. FILED 6-29-2011.
- 4,117,828. **FLEX-A-CHILL (STANDARD CHARACTER)**, CFM CONSOLIDATED, INC., (U.S. CLS. 1, 5, 6, 10, 26 AND 46). SN 85-361,093. PUB. 1-10-2012. FILED 6-30-2011.
- 4,117,881. **EXTREME ADHESIVES (STANDARD CHARACTER)**, EXTREME ADHESIVES, INC., (U.S. CLS. 1, 5, 6, 10, 26 AND 46). SN 85-366,325. PUB. 1-10-2012. FILED 7-8-2011.
- 4,117,911. **CASTORCIN (STANDARD CHARACTER)**, VERTELLUS SPECIALTIES INC., (U.S. CLS. 1, 5, 6, 10, 26 AND 46). SN 85-368,083. PUB. 1-10-2012. FILED 7-11-2011.
- 4,118,282. **AMERIGUARD (STANDARD CHARACTER)**, SAPP BROS., INC., MULTIPLE CLASS, (INT. CLS. 1 AND 4), (U.S. CLS. 1, 5, 6, 10, 15, 26 AND 46). SN 85-380,360. PUB. 1-10-2012. FILED 7-25-2011.
- 4,118,474. **VARNICLEAN (STANDARD CHARACTER)**, SCHAEFFER MFG. CO., (U.S. CLS. 1, 5, 6, 10, 26 AND 46). SN 85-393,599. PUB. 1-10-2012. FILED 8-9-2011.
- 4,118,525. **HUXP (STANDARD CHARACTER)**, HUMANZYME INC., (U.S. CLS. 1, 5, 6, 10, 26 AND 46). SN 85-394,821. PUB. 1-10-2012. FILED 8-10-2011.
- 4,118,527. **XENO AND DESIGN. HUMANZYME INC.**, (U.S. CLS. 1, 5, 6, 10, 26 AND 46). SN 85-394,838. PUB. 1-10-2012. FILED 8-10-2011.
- 4,118,541. **DNAUS (STANDARD CHARACTER)**, LEGENE BIOSCIENCES CORP., (U.S. CLS. 1, 5, 6, 10, 26 AND 46). SN 85-395,019. PUB. 1-10-2012. FILED 8-11-2011.
- 4,118,557. **RNAUS (STANDARD CHARACTER)**, LEGENE BIOSCIENCES CORP., (U.S. CLS. 1, 5, 6, 10, 26 AND 46). SN 85-395,374. PUB. 1-10-2012. FILED 8-11-2011.

- 4,118,572. **MR-97 (STANDARD CHARACTER)**. COHO SALES LLC, (U.S. CLS. 1, 5, 6, 10, 26 AND 46). SN 85-395,725. PUB. 1-10-2012. FILED 8-11-2011.
- 4,118,575. **MISCELLANEOUS DESIGN**. COUNTRY BOY SEED, INC., (U.S. CLS. 1, 5, 6, 10, 26 AND 46). SN 85-395,755. PUB. 1-10-2012. FILED 8-11-2011.
- 4,118,665. **ACCUSTAIN (STANDARD CHARACTER)**. SIGMA-ALDRICH CO. LLC, (U.S. CLS. 1, 5, 6, 10, 26 AND 46). SN 85-397,621. PUB. 1-10-2012. FILED 8-15-2011.
- 4,118,726. **ADDGENE AND DESIGN**. ADDGENE, INC., MULTIPLE CLASS, (INT. CLS. 1, 35 AND 42), (U.S. CLS. 1, 5, 6, 10, 26, 46, 100, 101 AND 102). SN 85-445,208. PUB. 1-10-2012. FILED 10-12-2011.
- 4,118,743. **BLUE EARTH LABS (STANDARD CHARACTER)**. BLUE EARTH LABS, LLC, (U.S. CLS. 1, 5, 6, 10, 26 AND 46). SN 85-975,156. PUB. 1-10-2012. FILED 7-29-2010.

CLASS 2—PAINTS

- 4,116,564. **MUDD OFF AND DESIGN**. ENERGY RELEASE, LLC, MULTIPLE CLASS, (INT. CLS. 2 AND 3), (U.S. CLS. 1, 4, 6, 11, 16, 50, 51 AND 52). SN 76-705,526. PUB. 10-4-2011. FILED 12-1-2010.
- 4,116,565. **MUDD OFF (STYLIZED)**. ENERGY RELEASE, LLC, MULTIPLE CLASS, (INT. CLS. 2 AND 3), (U.S. CLS. 1, 4, 6, 11, 16, 50, 51 AND 52). SN 76-705,527. PUB. 10-4-2011. FILED 12-1-2010.
- 4,116,678 (*See Class 1 for this trademark*).
- 4,116,704 (*See Class 1 for this trademark*).
- 4,116,788. **SELEKTOPE (STANDARD CHARACTER)**. I-TECH AB, MULTIPLE CLASS, (INT. CLS. 2 AND 5), (U.S. CLS. 6, 11, 16, 18, 44, 46, 51 AND 52). SN 79-097,393. PUB. 1-10-2012. FILED 2-4-2011.
- 4,116,873. **REDUSOL (STYLIZED)**. MARDENKRO HOLDING B.V., (U.S. CLS. 6, 11 AND 16). SN 79-104,690. PUB. 1-10-2012. FILED 8-9-2011.
- 4,117,174. **GRADUATE (STANDARD CHARACTER)**. DALER-ROWNEY LIMITED, MULTIPLE CLASS, (INT. CLS. 2 AND 16), (U.S. CLS. 2, 5, 6, 11, 16, 22, 23, 29, 37, 38 AND 50). SN 85-236,817. PUB. 1-10-2012. FILED 2-8-2011.
- 4,117,423 (*See Class 1 for this trademark*).
- 4,117,492. **HULL PAINTAS (STANDARD CHARACTER)**. BOSTON E LAB, INC., (U.S. CLS. 6, 11 AND 16). SN 85-300,752. PUB. 1-10-2012. FILED 4-21-2011.
- 4,117,571 (*See Class 1 for this trademark*).
- 4,117,880. **SIKACOAT (STANDARD CHARACTER)**. SIKA AG, MULTIPLE CLASS, (INT. CLS. 2 AND 17), (U.S. CLS. 1, 5, 6, 11, 12, 13, 16, 35 AND 50). SN 85-366,289. PUB. 12-6-2011. FILED 7-8-2011.
- 4,118,119. **WAHIBA (STANDARD CHARACTER)**. MERCK KGAA, (U.S. CLS. 6, 11 AND 16). SN 85-374,758. PUB. 1-10-2012. FILED 7-19-2011.
- 4,118,673. **VARICURE (STANDARD CHARACTER)**. AKZO NOBEL COATINGS INTERNATIONAL B.V., (U.S. CLS. 6, 11 AND 16). SN 85-402,009. PUB. 1-10-2012. FILED 8-19-2011.

CLASS 3—COSMETICS AND CLEANING PREPARATIONS

- 4,116,564 (*See Class 2 for this trademark*).
- 4,116,565 (*See Class 2 for this trademark*).
- 4,116,566. **ESHAVE AND DESIGN**. MALKA, DANIELLE, MULTIPLE CLASS, (INT. CLS. 3, 8 AND 21), (U.S. CLS. 1, 2, 4, 6, 13, 23, 28, 29, 30, 33, 40, 44, 50, 51 AND 52). SN 76-706,048. PUB. 1-10-2012. FILED 1-19-2011.
- 4,116,600. **SKIN NUTRITION (STANDARD CHARACTER)**. SMITH & VANDIVER, CORP., (U.S. CLS. 1, 4, 6, 50, 51 AND 52). SN 77-492,026. PUB. 1-10-2012. FILED 6-5-2008.
- 4,116,603. **K KARYN'S KARE AND DESIGN**. KARYN'S FRESH CORNER CAFE, INC., (U.S. CLS. 1, 4, 6, 50, 51 AND 52). SN 77-522,832. PUB. 1-10-2012. FILED 7-15-2008.
- 4,116,615. **SUPERIA (STANDARD CHARACTER)**. ITC LIMITED, (U.S. CLS. 1, 4, 6, 50, 51 AND 52). SN 77-746,134. PUB.

- 1-10-2012. FILED 5-28-2009.
- 4,116,676. **OVAL AND DESIGN**. 5/8EME COSMETO, (U.S. CLS. 1, 4, 6, 50, 51 AND 52). SN 79-042,003. PUB. 1-10-2012. FILED 7-13-2007.
- 4,116,704 (*See Class 1 for this trademark*).
- 4,116,706. **LET IT RAIN (STANDARD CHARACTER)**. BASIC-NET SPA, MULTIPLE CLASS, (INT. CLS. 3, 9, 18 AND 25), (U.S. CLS. 1, 2, 3, 4, 6, 21, 22, 23, 26, 36, 38, 39, 41, 50, 51 AND 52). SN 79-087,306. PUB. 1-10-2012. FILED 1-21-2010.
- 4,116,733. **ANTEIMOS (STANDARD CHARACTER)**. MATSUKI TEI, (U.S. CLS. 1, 4, 6, 50, 51 AND 52). SN 79-094,168. PUB. 1-10-2012. FILED 2-8-2011.
- 4,116,741. **KEY-RING (STANDARD CHARACTER)**. ENSWICO IP AG, MULTIPLE CLASS, (INT. CLS. 3 AND 11), (U.S. CLS. 1, 4, 6, 13, 21, 23, 31, 34, 50, 51 AND 52). SN 79-094,906. PUB. 1-10-2012. FILED 3-3-2011.
- 4,116,742. **KEY-VENTIL, KEY-VALVE (STANDARD CHARACTER)**. ENSWICO IP AG, MULTIPLE CLASS, (INT. CLS. 3 AND 11), (U.S. CLS. 1, 4, 6, 13, 21, 23, 31, 34, 50, 51 AND 52). SN 79-094,907. PUB. 1-10-2012. FILED 3-3-2011.
- 4,116,768. **MAURO GRIFONI (STANDARD CHARACTER)**. MANILA S.R.L., MULTIPLE CLASS, (INT. CLS. 3, 9, 14 AND 18), (U.S. CLS. 1, 2, 3, 4, 6, 21, 22, 23, 26, 27, 28, 36, 38, 41, 50, 51 AND 52). SN 79-096,179. PUB. 1-10-2012. FILED 2-10-2011.
- 4,116,773. **MISCELLANEOUS DESIGN**. OBSHCHESTVO S OGRANICHENNOY OTVETSTVENNOSTYU "ASTRO-FARMA", MULTIPLE CLASS, (INT. CLS. 3 AND 5), (U.S. CLS. 1, 4, 6, 18, 44, 46, 50, 51 AND 52). SN 79-096,281. PUB. 1-10-2012. FILED 2-9-2011.
- 4,116,782. **AMALTEA (STYLIZED)**. L'AMBRE GROUPE INTERNATIONAL SP. Z O.O., MULTIPLE CLASS, (INT. CLS. 3 AND 35), (U.S. CLS. 1, 4, 6, 50, 51, 52, 100, 101 AND 102). SN 79-096,777. PUB. 1-10-2012. FILED 1-11-2011.
- 4,116,789. **KUCCIA (STANDARD CHARACTER)**. GOGGIN SORAYA, MULTIPLE CLASS, (INT. CLS. 3, 25 AND 35), (U.S. CLS. 1, 4, 6, 22, 39, 50, 51, 52, 100, 101 AND 102). SN 79-097,414. PUB. 1-10-2012. FILED 4-6-2011.
- 4,116,791 (*See Class 1 for this trademark*).
- 4,116,846. **LES COMETES RESSOURCABLES (STANDARD CHARACTER)**. CLARINS FRAGRANCE GROUP, (U.S. CLS. 1, 4, 6, 50, 51 AND 52). SN 79-101,133. PUB. 1-10-2012. FILED 4-12-2011.
- 4,116,879. **HERBLINIC RESTORATIVE AMPOULES AND DESIGN**. AMOREPACIFIC CORPORATION, (U.S. CLS. 1, 4, 6, 50, 51 AND 52). SN 85-012,779. PUB. 1-10-2012. FILED 4-13-2010.
- 4,116,910. **PETITE MERVEILLE DE L'EAU DES MERVEILLES (STANDARD CHARACTER)**. COMPTOIR NOUVEAU DE LA PARFUMERIE, (U.S. CLS. 1, 4, 6, 50, 51 AND 52). SN 85-078,432. PUB. 1-10-2012. FILED 7-6-2010.
- 4,116,961. **NOURISHE DNA REPAIR (STANDARD CHARACTER)**. NOURISHE LLC, (U.S. CLS. 1, 4, 6, 50, 51 AND 52). SN 85-140,725. PUB. 1-10-2012. FILED 9-29-2010.
- 4,117,012. **GINGER CLEAN AND DESIGN**. GINGER CLEAN, INC., (U.S. CLS. 1, 4, 6, 50, 51 AND 52). SN 85-195,837. PUB. 1-10-2012. FILED 12-11-2010.
- 4,117,052. **HYDRO-AID MOISTURIZING LIFTING MIST AND DESIGN**. AMOREPACIFIC CORPORATION, (U.S. CLS. 1, 4, 6, 50, 51 AND 52). SN 85-216,682. PUB. 1-10-2012. FILED 1-13-2011.
- 4,117,129. **TOUS COLORS (STANDARD CHARACTER)**. S. TOUS, S.L., (U.S. CLS. 1, 4, 6, 50, 51 AND 52). SN 85-231,418. PUB. 1-10-2012. FILED 2-1-2011.
- 4,117,183. **XSOL (STANDARD CHARACTER)**. DIOMED DEVELOPMENTS LIMITED, MULTIPLE CLASS, (INT. CLS. 3 AND 5), (U.S. CLS. 1, 4, 6, 18, 44, 46, 50, 51 AND 52). SN 85-238,602. PUB. 1-10-2012. FILED 2-10-2011.
- 4,117,198. **P PET CARE CENTER AND DESIGN**. PET CARE CENTER, INC., MULTIPLE CLASS, (INT. CLS. 3, 5, 35, 43 AND 44), (U.S. CLS. 1, 4, 6, 18, 44, 46, 50, 51, 52, 100, 101 AND 102). SN 85-240,547. PUB. 1-10-2012. FILED 2-11-2011.
- 4,117,204. **SKIN KIND SOLUTIONS FOR MEN AND DESIGN**. MANKIND SYDNEY PTY LTD, (U.S. CLS. 1, 4, 6, 50, 51 AND 52). SN 85-241,120. PUB. 1-10-2012. FILED 2-13-2011.
- 4,117,288. **THAT'S WHAT SHE SAID (STANDARD CHARACTER)**. EVERYDAY SHORTS INCORPORATED, (U.S. CLS. 1, 4, 6, 50, 51 AND 52). SN 85-258,853. PUB. 1-10-2012. FILED

- 3-5-2011.
- 4,117,329. **FAUX AND DESIGN. FAUX LTD., TA FAUX LTD.**, (U.S. CLS. 1, 4, 6, 50, 51 AND 52). SN 85-267,226. PUB. 1-10-2012. FILED 3-15-2011.
- 4,117,425. **E-9VE (STANDARD CHARACTER). LO VI POR TV, LLC**, (U.S. CLS. 1, 4, 6, 50, 51 AND 52). SN 85-288,533. PUB. 1-10-2012. FILED 4-7-2011.
- 4,117,426. **DERMASYSTEM (STANDARD CHARACTER). SUAREZ-MENENDEZ, JORGE**, (U.S. CLS. 1, 4, 6, 50, 51 AND 52). SN 85-288,556. PUB. 1-10-2012. FILED 4-7-2011.
- 4,117,464. **IT'S TIME TO FACE THE MUSIC (STANDARD CHARACTER). FREMANTLEMEDIA LIMITED, AND SIMCO LIMITED**, (U.S. CLS. 1, 4, 6, 50, 51 AND 52). SN 85-295,182. PUB. 1-10-2012. FILED 4-14-2011.
- 4,117,505. **BABY MANTRA NATURAL LOVE. DEVOTION. AND DESIGN. GREENKARMA, LLC**, (U.S. CLS. 1, 4, 6, 50, 51 AND 52). SN 85-302,632. PUB. 1-10-2012. FILED 4-22-2011.
- 4,117,529. **ST. LUKE'S AND DESIGN. THE BRITISH DISPENSARY (L.P.) CO., LTD.**, MULTIPLE CLASS, (INT. CLS. 3 AND 5), (U.S. CLS. 1, 4, 6, 18, 44, 46, 50, 51 AND 52). SN 85-308,230. PUB. 1-10-2012. FILED 4-29-2011.
- 4,117,647. **HOODOO ROOTS (STANDARD CHARACTER). ANZLOWAR, DARA E., DBA HOODOO ROOTS**, (U.S. CLS. 1, 4, 6, 50, 51 AND 52). SN 85-333,256. PUB. 1-10-2012. FILED 5-29-2011.
- 4,117,675. **I THINK YOU ARE WONDERFUL (STANDARD CHARACTER). PHILOSOPHY, INC.**, (U.S. CLS. 1, 4, 6, 50, 51 AND 52). SN 85-338,508. PUB. 1-10-2012. FILED 6-6-2011.
- 4,117,742. **RAUL E NEW YORK AND DESIGN. RAUL EQUINE, INC., DBA RAUL E NEW YORK**, MULTIPLE CLASS, (INT. CLS. 3, 14, 18, 25 AND 28), (U.S. CLS. 1, 2, 3, 4, 6, 22, 23, 27, 28, 38, 39, 41, 50, 51 AND 52). SN 85-351,252. PUB. 1-10-2012. FILED 6-21-2011.
- 4,117,791. **INCOGNITO (STANDARD CHARACTER). FINANZ ST. HONORE, B.V.**, (U.S. CLS. 1, 4, 6, 50, 51 AND 52). SN 85-356,918. PUB. 1-10-2012. FILED 6-27-2011.
- 4,117,800. **JENORIS (STANDARD CHARACTER). GLIKSMAN COSMETICS LTD.**, (U.S. CLS. 1, 4, 6, 50, 51 AND 52). SN 85-358,467. PUB. 1-10-2012. FILED 6-28-2011.
- 4,117,835. **SASSA BELLA AND DESIGN. SASSA BELLA, DBA SASSA BELLA**, (U.S. CLS. 1, 4, 6, 50, 51 AND 52). SN 85-362,375. PUB. 1-10-2012. FILED S.R. 7-2-2011; AM. P.R. 11-9-2011.
- 4,117,855. **NATURAL FACE (STANDARD CHARACTER). TOO FACED COSMETICS, INC.**, (U.S. CLS. 1, 4, 6, 50, 51 AND 52). SN 85-364,792. PUB. 1-10-2012. FILED 7-6-2011.
- 4,117,861. **T.R.E.E. BODY LINE THE RAW EARTH EXPERIENCE "LET THE HAND OF NATURE SOFTEN YOUR SKIN" AND DESIGN. VAHLE, PAMELA**, (U.S. CLS. 1, 4, 6, 50, 51 AND 52). SN 85-365,044. PUB. 1-10-2012. FILED 7-7-2011.
- 4,117,899. **BARBARA ELIZABETH AND DESIGN. NEILL-ROMINGER, BARBARA ELIZABETH, AKA NEILL, BARBARA ELIZABETH**, (U.S. CLS. 1, 4, 6, 50, 51 AND 52). SN 85-367,163. PUB. 1-10-2012. FILED 7-9-2011.
- 4,117,931. **PEACH LEOPARD BRIGHTENING & PERFECTING BRONZER (STANDARD CHARACTER). TOO FACED COSMETICS, INC.**, (U.S. CLS. 1, 4, 6, 50, 51 AND 52). SN 85-369,011. PUB. 1-10-2012. FILED 7-12-2011.
- 4,117,970. **CHESTIE (STANDARD CHARACTER). SIX BUTTONS, INC.**, (U.S. CLS. 1, 4, 6, 50, 51 AND 52). SN 85-370,748. PUB. 1-10-2012. FILED 7-13-2011.
- 4,118,006. **PREMIUM HOME WHITENING SYSTEM AND DESIGN. LAJOUS, LUIS**, (U.S. CLS. 1, 4, 6, 50, 51 AND 52). SN 85-371,964. PUB. 1-10-2012. FILED 7-14-2011.
- 4,118,070. **OYB AND DESIGN. GENOME COSMETICS LLC, DBA OBEY YOUR BODY LLC**, (U.S. CLS. 1, 4, 6, 50, 51 AND 52). SN 85-373,722. PUB. 1-10-2012. FILED 7-18-2011.
- 4,118,173. **CLR BATH & KITCHEN AND DESIGN. JELMAR, LLC**, (U.S. CLS. 1, 4, 6, 50, 51 AND 52). SN 85-375,757. PUB. 1-10-2012. FILED 7-20-2011.
- 4,118,174. **WE CLEAN MORE THAN YOU THINK (STANDARD CHARACTER). JELMAR, LLC**, (U.S. CLS. 1, 4, 6, 50, 51 AND 52). SN 85-375,765. PUB. 1-10-2012. FILED 7-20-2011.
- 4,118,245. **NICK (STANDARD CHARACTER). PERFECT PLUS, INC.**, (U.S. CLS. 1, 4, 6, 50, 51 AND 52). SN 85-378,427. PUB. 1-10-2012. FILED 7-22-2011.
- 4,118,246. **TRADITIONS BY NICK CHAVEZ (STANDARD CHARACTER). PERFECT PLUS, INC.**, (U.S. CLS. 1, 4, 6, 50, 51 AND 52). SN 85-378,520. PUB. 1-10-2012. FILED 7-22-2011.
- 4,118,250. **BARR-CO (STANDARD CHARACTER). K. HALL STUDIO INC., MULTIPLE CLASS, (INT. CLS. 3 AND 4)**, (U.S. CLS. 1, 4, 6, 15, 50, 51 AND 52). SN 85-378,611. PUB. 1-10-2012. FILED 7-22-2011.
- 4,118,294. **SHELBY (STANDARD CHARACTER). CARROLL HALL SHELBY TRUST, MULTIPLE CLASS, (INT. CLS. 3, 6, 9, 11, 12, 20, 24 AND 26)**, (U.S. CLS. 1, 2, 4, 6, 12, 13, 14, 19, 21, 22, 23, 25, 26, 31, 32, 34, 35, 36, 37, 38, 39, 40, 42, 44, 50, 51 AND 52). SN 85-381,133. PUB. 1-10-2012. FILED 7-26-2011.
- 4,118,362. **OLÉCULE AND DESIGN. KANGWONGFU INTERNATIONAL CO., LTD.**, (U.S. CLS. 1, 4, 6, 50, 51 AND 52). SN 85-390,242. PUB. 1-10-2012. FILED 8-4-2011.
- 4,118,376. **E FACTOR-8 COMPLEX (STANDARD CHARACTER). BAD LOVE COSMETICS COMPANY LLC, DBA ELITE THERAPEUTICS**, (U.S. CLS. 1, 4, 6, 50, 51 AND 52). SN 85-390,932. PUB. 1-10-2012. FILED 8-5-2011.
- 4,118,387. **ATERRA AND DESIGN. B4 VENTURES, L.L.C.**, (U.S. CLS. 1, 4, 6, 50, 51 AND 52). SN 85-391,940. PUB. 1-10-2012. FILED 8-8-2011.
- 4,118,419. **HULA BOAT CARE (STANDARD CHARACTER). MAX WORX, LLC**, (U.S. CLS. 1, 4, 6, 50, 51 AND 52). SN 85-392,651. PUB. 1-10-2012. FILED 8-8-2011.
- 4,118,421. **WHAT ROCKS YOUR BOAT? (STANDARD CHARACTER). MAX WORX, LLC**, (U.S. CLS. 1, 4, 6, 50, 51 AND 52). SN 85-392,666. PUB. 1-10-2012. FILED 8-8-2011.
- 4,118,438. **LUSH (STANDARD CHARACTER). COSMETIC WARRIORS LTD.**, (U.S. CLS. 1, 4, 6, 50, 51 AND 52). SN 85-393,077. PUB. 1-10-2012. FILED 8-9-2011.
- 4,118,444. **MAKE UP SEXX (STANDARD CHARACTER). PYE RICHARD L, TA MAKE UP SEXX**, (U.S. CLS. 1, 4, 6, 50, 51 AND 52). SN 85-393,132. PUB. 1-10-2012. FILED 8-9-2011.
- 4,118,561. **REFRESHING RAIN (STANDARD CHARACTER). THE PROCTER & GAMBLE COMPANY**, (U.S. CLS. 1, 4, 6, 50, 51 AND 52). SN 85-395,424. PUB. 1-10-2012. FILED 8-11-2011.
- 4,118,592. **YOUTHBUTTER (STANDARD CHARACTER). NATURAL EDGE HAWAII, INC.**, (U.S. CLS. 1, 4, 6, 50, 51 AND 52). SN 85-395,979. PUB. 1-10-2012. FILED 8-11-2011.
- 4,118,623. **WHISPER HILL (STANDARD CHARACTER). WHISPER HILL, LLC**, (U.S. CLS. 1, 4, 6, 50, 51 AND 52). SN 85-396,827. PUB. 1-10-2012. FILED 8-12-2011.
- 4,118,677. **TOO FACED (STYLIZED). TOO FACED COSMETICS, INC.**, (U.S. CLS. 1, 4, 6, 50, 51 AND 52). SN 85-404,068. PUB. 1-10-2012. FILED 8-22-2011.
- 4,118,736. **CLR SEPTIC TREATMENT & DRAIN CARE AND DESIGN. JELMAR, LLC**, (U.S. CLS. 1, 4, 6, 50, 51 AND 52). SN 85-459,220. PUB. 1-10-2012. FILED 10-28-2011.
- 4,118,737. **CLR SEPTIC AND DESIGN. JELMAR, LLC**, (U.S. CLS. 1, 4, 6, 50, 51 AND 52). SN 85-459,227. PUB. 1-10-2012. FILED 10-28-2011.
- 4,118,744. **ALOE MED (STANDARD CHARACTER). LYDIAN MARKETING GROUP, LLC, MULTIPLE CLASS, (INT. CLS. 3 AND 32)**, (U.S. CLS. 1, 4, 6, 45, 46, 48, 50, 51 AND 52). SN 85-975,873. PUB. 1-10-2012. FILED 3-1-2011.

CLASS 4—LUBRICANTS AND FUELS

- 4,116,704 (*See Class 1 for this trademark*).
- 4,116,931. **RAVI PETRO AND DESIGN. NAEEM KHALID**, (U.S. CLS. 1, 6 AND 15). SN 85-108,417. PUB. 1-10-2012. FILED 8-16-2010.
- 4,117,423 (*See Class 1 for this trademark*).
- 4,117,615. **VINTAGE FLOWERS (STANDARD CHARACTER). NEDBOY, ROBIN L.**, (U.S. CLS. 1, 6 AND 15). SN 85-326,107. PUB. 1-10-2012. FILED 5-20-2011.
- 4,117,686. **ANTIQUÉ FLOWERS (STANDARD CHARACTER). NEDBOY, ROBIN L.**, (U.S. CLS. 1, 6 AND 15). SN 85-341,156. PUB. 1-10-2012. FILED 6-8-2011.
- 4,118,250 (*See Class 3 for this trademark*).
- 4,118,282 (*See Class 1 for this trademark*).
- 4,118,460. **LOVE'S IMPRINT (STANDARD CHARACTER). SOUTH BEACH CANDLE COMPANY**, (U.S. CLS. 1, 6 AND 15). SN 85-393,360. PUB. 1-10-2012. FILED 8-9-2011.

4,118,745. **TEXPAR (STANDARD CHARACTER)**. TEXPAR ENERGY, L.L.C., MULTIPLE CLASS, (INT. CLS. 4, 19, 37 AND 39), (U.S. CLS. 1, 6, 12, 15, 33, 50, 100, 103, 105 AND 106). SN 85-975,935. PUB. 1-10-2012. FILED 3-2-2011.

CLASS 5—PHARMACEUTICALS

4,116,552. **NAKED BAR (STANDARD CHARACTER)**. LEE, SEAN SANGSOO, (U.S. CLS. 6, 18, 44, 46, 51 AND 52). SN 76-677,088. PUB. 5-27-2008. FILED 5-18-2007.

4,116,553. **AROMA THERAPIE (STANDARD CHARACTER)**. THERAPIE LLC, (U.S. CLS. 6, 18, 44, 46, 51 AND 52). SN 76-683,601. PUB. 1-10-2012. FILED 11-2-2012.

4,116,604. **K KARYN'S KARE AND DESIGN**. KARYN'S FRESH CORNER CAFE, INC., (U.S. CLS. 6, 18, 44, 46, 51 AND 52). SN 77-522,904. PUB. 1-10-2012. FILED 7-15-2008.

4,116,659. **DOZE-OFF (STANDARD CHARACTER)**. ORGANIC HEALTH LABS, LLC, (U.S. CLS. 6, 18, 44, 46, 51 AND 52). SN 77-929,882. PUB. 1-10-2012. FILED 2-6-2010.

4,116,670 (*See Class 1 for this trademark*).

4,116,673. **ASOLZA (STANDARD CHARACTER)**. VALEANT INTERNATIONAL (BARBADOS) SRL, (U.S. CLS. 6, 18, 44, 46, 51 AND 52). SN 78-851,378. PUB. 1-10-2012. FILED 3-31-2006.

4,116,675 (*See Class 1 for this trademark*).

4,116,692. **CONCORDIX (STANDARD CHARACTER)**. AYANDA AS, MULTIPLE CLASS, (INT. CLS. 5 AND 29), (U.S. CLS. 6, 18, 44, 46, 51 AND 52). SN 79-083,502. PUB. 3-1-2011. FILED 3-1-2010.

4,116,704 (*See Class 1 for this trademark*).

4,116,735. **MISCELLANEOUS DESIGN**. SANOFI, MULTIPLE CLASS, (INT. CLS. 5, 16, 35, 38, 41 AND 44), (U.S. CLS. 2, 5, 6, 18, 22, 23, 29, 37, 38, 44, 46, 50, 51, 52, 100, 101, 102, 104 AND 107). SN 79-094,394. PUB. 1-10-2012. FILED 12-16-2010.

4,116,746. **INFLACAM (STANDARD CHARACTER)**. VIRBAC, (U.S. CLS. 6, 18, 44, 46, 51 AND 52). SN 79-095,139. PUB. 1-10-2012. FILED 2-25-2011.

4,116,747. **DOLOCAM (STANDARD CHARACTER)**. VIRBAC, (U.S. CLS. 6, 18, 44, 46, 51 AND 52). SN 79-095,140. PUB. 1-10-2012. FILED 2-25-2011.

4,116,748. **QUINOTRYL (STANDARD CHARACTER)**. VIRBAC, (U.S. CLS. 6, 18, 44, 46, 51 AND 52). SN 79-095,141. PUB. 1-10-2012. FILED 2-25-2011.

4,116,762. **UNIK2 (STANDARD CHARACTER)**. FRUTAROM NETHERLANDS B.V., MULTIPLE CLASS, (INT. CLS. 5 AND 29), (U.S. CLS. 6, 18, 44, 46, 51 AND 52). SN 79-095,910. PUB. 1-10-2012. FILED 2-22-2011.

4,116,766. **COSAFIX (STANDARD CHARACTER)**. KARL WERKMEISTER. MEDIZINISCHE LEIBBINDEN, INH., HANS-JÜRGEN GERMERODT, (U.S. CLS. 6, 18, 44, 46, 51 AND 52). SN 79-096,044. PUB. 1-10-2012. FILED 10-1-2010.

4,116,773 (*See Class 3 for this trademark*).

4,116,777. **Q&P (STYLIZED)**. KOWA COMPANY, LTD., (U.S. CLS. 6, 18, 44, 46, 51 AND 52). SN 79-096,547. PUB. 1-10-2012. FILED 3-30-2011.

4,116,788 (*See Class 2 for this trademark*).

4,116,852. **QUICK UP (STANDARD CHARACTER)**. VOCO GMBH, MULTIPLE CLASS, (INT. CLS. 5 AND 10), (U.S. CLS. 6, 18, 26, 39, 44, 46, 51 AND 52). SN 79-101,798. PUB. 1-10-2012. FILED 6-10-2011.

4,116,870. **CERTASEVEN (STANDARD CHARACTER)**. NOVO NORDISK HEALTH CARE AG, (U.S. CLS. 6, 18, 44, 46, 51 AND 52). SN 79-104,551. PUB. 1-10-2012. FILED 9-21-2011.

4,116,871. **EVOSEVEN (STANDARD CHARACTER)**. NOVO NORDISK HEALTH CARE AG, (U.S. CLS. 6, 18, 44, 46, 51 AND 52). SN 79-104,552. PUB. 1-10-2012. FILED 9-21-2011.

4,116,911. **RELIEF POD (STANDARD CHARACTER)**. RELIEF POD INTERNATIONAL, LLC, MULTIPLE CLASS, (INT. CLS. 5 AND 9), (U.S. CLS. 6, 18, 21, 23, 26, 36, 38, 44, 46, 51 AND 52). SN 85-084,870. PUB. 1-10-2012. FILED 7-14-2010.

4,116,912. **RELIEF POD AND DESIGN**. RELIEF POD INTERNATIONAL, LLC, MULTIPLE CLASS, (INT. CLS. 5 AND 9), (U.S. CLS. 6, 18, 21, 23, 26, 36, 38, 44, 46, 51 AND 52). SN 85-084,923. PUB. 1-10-2012. FILED 7-14-2010.

4,116,932. **SMOOTHING BODY PEEL (STANDARD CHARACTER)**. PHYSICIANS CARE ALLIANCE, LLC, (U.S. CLS.

6, 18, 44, 46, 51 AND 52). SN 85-109,668. PUB. 1-10-2012. FILED 8-17-2010.

4,116,936. **TILE DOCTOR SHIELD (STANDARD CHARACTER)**. TILE MEDIA PROPERTIES, INC., (U.S. CLS. 6, 18, 44, 46, 51 AND 52). SN 85-118,566. PUB. 1-18-2011. FILED 8-30-2010.

4,116,951. **5-HOUR ENERGY EXTRA STRENGTH AND DESIGN**. INNOVATION VENTURES, LLC, MULTIPLE CLASS, (INT. CLS. 5 AND 32), (U.S. CLS. 6, 18, 44, 45, 46, 48, 51 AND 52). SN 85-132,099. PUB. 1-10-2012. FILED 9-17-2010.

4,116,960. **NUTRELLE (STANDARD CHARACTER)**. LIQUID HEALTH LABS, INC., (U.S. CLS. 6, 18, 44, 46, 51 AND 52). SN 85-139,986. PUB. 10-4-2011. FILED 9-28-2010.

4,116,989. **WISDOM'S CHOICE (STANDARD CHARACTER)**. BERTINO, WILLIAM, J., (U.S. CLS. 6, 18, 44, 46, 51 AND 52). SN 85-183,394. PUB. 1-10-2012. FILED 11-23-2010.

4,117,025. **ALLMAX NUTRITION AND DESIGN**. ALLMAX NUTRITION, INC., (U.S. CLS. 6, 18, 44, 46, 51 AND 52). SN 85-200,770. PUB. 1-10-2012. FILED 12-17-2010.

4,117,026. **ALLMAX (STANDARD CHARACTER)**. ALLMAX NUTRITION, INC., (U.S. CLS. 6, 18, 44, 46, 51 AND 52). SN 85-200,783. PUB. 1-10-2012. FILED 12-17-2010.

4,117,108. **COLD TODAY...GONE TOMORROW (OR REALLY, REALLY SOON) (STANDARD CHARACTER)**. PROPHASE LABS, INC., FORMERLY THE QUIGLEY CORPORATION, (U.S. CLS. 6, 18, 44, 46, 51 AND 52). SN 85-227,786. PUB. 1-10-2012. FILED 1-27-2011.

4,117,168. **NESDUON (STANDARD CHARACTER)**. TAKEDA PHARMACEUTICAL COMPANY LIMITED, (U.S. CLS. 6, 18, 44, 46, 51 AND 52). SN 85-235,819. PUB. 1-10-2012. FILED 2-7-2011.

4,117,169. **NLYNQ (STANDARD CHARACTER)**. TAKEDA PHARMACEUTICAL COMPANY LIMITED, (U.S. CLS. 6, 18, 44, 46, 51 AND 52). SN 85-235,894. PUB. 1-10-2012. FILED 2-7-2011.

4,117,183 (*See Class 3 for this trademark*).

4,117,185. **LASKIN MEDICAL SKIN SYSTEMS (STANDARD CHARACTER)**. LASKIN MEDICAL, LLC, (U.S. CLS. 6, 18, 44, 46, 51 AND 52). SN 85-238,872. PUB. 1-10-2012. FILED 2-10-2011.

4,117,198 (*See Class 3 for this trademark*).

4,117,234. **QWICK-ARREST (STANDARD CHARACTER)**. YOUNG ESSENTIAL SKINCARE, INC, DBA YES, INC., (U.S. CLS. 6, 18, 44, 46, 51 AND 52). SN 85-246,550. PUB. 1-10-2012. FILED 2-18-2011.

4,117,358. **HERBAIA AND DESIGN**. BOWERS, GINA M, (U.S. CLS. 6, 18, 44, 46, 51 AND 52). SN 85-273,572. PUB. 1-10-2012. FILED 3-22-2011.

4,117,408. **SMOKIN' RACK (STANDARD CHARACTER)**. SMOKIN' RACK PRODUCTS, LLC, MULTIPLE CLASS, (INT. CLS. 5 AND 28), (U.S. CLS. 6, 18, 22, 23, 38, 44, 46, 50, 51 AND 52). SN 85-283,979. PUB. 1-10-2012. FILED 4-1-2011.

4,117,518. **FS FORMULATED SCIENCES FS AND DESIGN**. ZOSMA VENTURES, INC., (U.S. CLS. 6, 18, 44, 46, 51 AND 52). SN 85-305,195. PUB. 1-10-2012. FILED 4-26-2011.

4,117,529 (*See Class 3 for this trademark*).

4,117,636. **V VAN LEER AND DESIGN**. BARRY CALLEBAUT AG, MULTIPLE CLASS, (INT. CLS. 5, 29 AND 30), (U.S. CLS. 6, 18, 44, 46, 51 AND 52). SN 85-331,387. PUB. 1-10-2012. FILED 5-26-2011.

4,117,643. **VETGENIX (STANDARD CHARACTER)**. VETGENIX, LLC, (U.S. CLS. 6, 18, 44, 46, 51 AND 52). SN 85-332,843. PUB. 1-10-2012. FILED 5-27-2011.

4,117,644. **VETGENIX AND DESIGN**. VETGENIX, LLC, (U.S. CLS. 6, 18, 44, 46, 51 AND 52). SN 85-332,885. PUB. 1-10-2012. FILED 5-27-2011.

4,117,704. **ZOLIDD (STANDARD CHARACTER)**. ADDBIO AB, MULTIPLE CLASS, (INT. CLS. 5 AND 10), (U.S. CLS. 6, 18, 26, 39, 44, 46, 51 AND 52). SN 85-344,543. PUB. 1-10-2012. FILED 6-13-2011.

4,117,731. **ELITE CASEIN (STANDARD CHARACTER)**. DYMATIZE ENTERPRISES, LLC, (U.S. CLS. 6, 18, 44, 46, 51 AND 52). SN 85-349,342. PUB. 1-10-2012. FILED 6-17-2011.

4,117,771. **AFTERSHOCK (STANDARD CHARACTER)**. PROLONG PHARMACEUTICALS, LLC, (U.S. CLS. 6, 18, 44, 46, 51 AND 52). SN 85-354,240. PUB. 1-10-2012. FILED 6-23-2011.

4,117,839. **MEDI PRIME INC. M.J.U AND DESIGN**. SHECH-

- TER, PAGIEL, AND SHECHTER, OFRA, MULTIPLE CLASS, (INT. CLS. 5 AND 16), (U.S. CLS. 2, 5, 6, 18, 22, 23, 29, 37, 38, 44, 46, 50, 51 AND 52). SN 85-363,040. PUB. 1-10-2012. FILED 7-5-2011.
- 4,117,843. **JIPANG GINGER (STANDARD CHARACTER)**. MAKISELIFEUP LABORATORY CO., LTD., (U.S. CLS. 6, 18, 44, 46, 51 AND 52). SN 85-363,432. PUB. 1-10-2012. FILED 7-5-2011.
- 4,117,887. **GLUCOSURE (STYLIZED)**. APEX BIOTECHNOLOGY CORPORATION, MULTIPLE CLASS, (INT. CLS. 5 AND 10), (U.S. CLS. 6, 18, 26, 39, 44, 46, 51 AND 52). SN 85-366,422. PUB. 1-10-2012. FILED 7-8-2011.
- 4,117,894. **NOLAN'S DIAPER RASH SPRAY (STANDARD CHARACTER)**. WAKE INNOVATION, LLC, (U.S. CLS. 6, 18, 44, 46, 51 AND 52). SN 85-366,828. PUB. 1-10-2012. FILED 7-8-2011.
- 4,117,945. **EASY TOUCH (STANDARD CHARACTER)**. MHC MEDICAL PRODUCTS, LLC, MULTIPLE CLASS, (INT. CLS. 5 AND 10), (U.S. CLS. 6, 18, 26, 39, 44, 46, 51 AND 52). SN 85-369,387. PUB. 1-10-2012. FILED 7-12-2011.
- 4,117,961. **A WHY GOOD COOKIE A MEAL DISGUISED AS A COOKIE AND DESIGN**. FETTERS, CAROLYN, (U.S. CLS. 6, 18, 44, 46, 51 AND 52). SN 85-370,401. PUB. 1-10-2012. FILED 7-13-2011.
- 4,117,965. **FINEST NATURAL (STANDARD CHARACTER)**. WALGREEN CO., (U.S. CLS. 6, 18, 44, 46, 51 AND 52). SN 85-370,584. PUB. 1-10-2012. FILED 7-13-2011.
- 4,117,976. **VITAMIN BLOCK AND DESIGN**. JOHN THOR, (U.S. CLS. 6, 18, 44, 46, 51 AND 52). SN 85-370,915. PUB. 1-10-2012. FILED 7-13-2011.
- 4,117,980. **EXOTEST (STANDARD CHARACTER)**. HANSABIOMED OU, (U.S. CLS. 6, 18, 44, 46, 51 AND 52). SN 85-370,994. PUB. 1-10-2012. FILED 7-14-2011.
- 4,118,086. **GOLD VET (STANDARD CHARACTER)**. KALA HEALTH ENRICHMENT, INC. DBA KALA HEALTH, (U.S. CLS. 6, 18, 44, 46, 51 AND 52). SN 85-374,178. PUB. 1-10-2012. FILED 7-18-2011.
- 4,118,152. **SILVERQUINE (STYLIZED)**. SILVERQUINE LLC, (U.S. CLS. 6, 18, 44, 46, 51 AND 52). SN 85-375,392. PUB. 1-10-2012. FILED 7-19-2011.
- 4,118,179. **WONDERSLIM AND DESIGN**. DIET DIRECT, INC., MULTIPLE CLASS, (INT. CLS. 5 AND 44), (U.S. CLS. 6, 18, 44, 46, 51, 52, 100 AND 101). SN 85-375,852. PUB. 1-10-2012. FILED 7-20-2011.
- 4,118,202. **PINKHEALTH AND DESIGN**. SAHAJANAND LIFE SCIENCES, INC., (U.S. CLS. 6, 18, 44, 46, 51 AND 52). SN 85-376,820. PUB. 1-10-2012. FILED 7-20-2011.
- 4,118,241. **MY CHEMO SUPPORT (STANDARD CHARACTER)**. LAKEWOOD RANCH NUTRITIONAL SCIENCES, LLC, (U.S. CLS. 6, 18, 44, 46, 51 AND 52). SN 85-378,188. PUB. 1-10-2012. FILED 7-22-2011.
- 4,118,242. **MY CHEMO SUPPORT AND DESIGN**. LAKEWOOD RANCH NUTRITIONAL SCIENCES, LLC, (U.S. CLS. 6, 18, 44, 46, 51 AND 52). SN 85-378,192. PUB. 1-10-2012. FILED 7-22-2011.
- 4,118,275. **BEE SCREEN AND DESIGN**. STRICTLY NATURAL PRODUCTS, INC., (U.S. CLS. 6, 18, 44, 46, 51 AND 52). SN 85-380,122. PUB. 1-10-2012. FILED 7-25-2011.
- 4,118,276. **QRX PHARMA (STANDARD CHARACTER)**. QRXPHARMA LIMITED, (U.S. CLS. 6, 18, 44, 46, 51 AND 52). SN 85-380,157. PUB. 1-10-2012. FILED 7-25-2011.
- 4,118,383. **HARLEY BABY HARLEY BABY AND DESIGN**. WANG HUANAN, (U.S. CLS. 6, 18, 44, 46, 51 AND 52). SN 85-391,742. PUB. 1-10-2012. FILED 8-8-2011.
- 4,118,386. **AVANT AND DESIGN**. B4 VENTURES, L.L.C., (U.S. CLS. 6, 18, 44, 46, 51 AND 52). SN 85-391,935. PUB. 1-10-2012. FILED 8-8-2011.
- 4,118,407. **BETHKIS (STANDARD CHARACTER)**. CHIESI FARMACEUTICI S.P.A., (U.S. CLS. 6, 18, 44, 46, 51 AND 52). SN 85-392,402. PUB. 1-10-2012. FILED 8-8-2011.
- 4,118,408. **DIMANTEX (STANDARD CHARACTER)**. CHIESI FARMACEUTICI S.P.A., (U.S. CLS. 6, 18, 44, 46, 51 AND 52). SN 85-392,412. PUB. 1-10-2012. FILED 8-8-2011.
- 4,118,409. **LIANSUR (STANDARD CHARACTER)**. CHIESI FARMACEUTICI S.P.A., (U.S. CLS. 6, 18, 44, 46, 51 AND 52). SN 85-392,418. PUB. 1-10-2012. FILED 8-8-2011.
- 4,118,410. **RESSOLI (STANDARD CHARACTER)**. CHIESI FARMACEUTICI S.P.A., (U.S. CLS. 6, 18, 44, 46, 51 AND 52). SN 85-392,430. PUB. 1-10-2012. FILED 8-8-2011.
- 4,118,411. **THEDROX (STANDARD CHARACTER)**. CHIESI FARMACEUTICI S.P.A., (U.S. CLS. 6, 18, 44, 46, 51 AND 52). SN 85-392,437. PUB. 1-10-2012. FILED 8-8-2011.
- 4,118,413. **PHYTOSPECTRUM (STANDARD CHARACTER)**. PROVINDUS, INC., (U.S. CLS. 6, 18, 44, 46, 51 AND 52). SN 85-392,530. PUB. 1-10-2012. FILED 8-8-2011.
- 4,118,427. **PRELIPID (STANDARD CHARACTER)**. PREVENTION MEDS, INC., (U.S. CLS. 6, 18, 44, 46, 51 AND 52). SN 85-392,878. PUB. 1-10-2012. FILED 8-9-2011.
- 4,118,457. **ALLERASE (STANDARD CHARACTER)**. BOHAGER HOLDINGS, LLC, (U.S. CLS. 6, 18, 44, 46, 51 AND 52). SN 85-393,335. PUB. 1-10-2012. FILED 8-9-2011.
- 4,118,486. **SPANISH FLY (STANDARD CHARACTER)**. RAGE BEVERAGES INC., MULTIPLE CLASS, (INT. CLS. 5 AND 32), (U.S. CLS. 6, 18, 44, 45, 46, 48, 51 AND 52). SN 85-393,884. PUB. 1-10-2012. FILED 8-9-2011.
- 4,118,488. **MINICAPS (STANDARD CHARACTER)**. SANCILIO AND COMPANY, INC., (U.S. CLS. 6, 18, 44, 46, 51 AND 52). SN 85-393,965. PUB. 1-10-2012. FILED 8-10-2011.
- 4,118,579. **EXLLEN (STANDARD CHARACTER)**. JOSIFA INTERNATIONAL INC., (U.S. CLS. 6, 18, 44, 46, 51 AND 52). SN 85-395,790. PUB. 1-10-2012. FILED 8-11-2011.
- 4,118,667. **GARDAVITA (STANDARD CHARACTER)**. TUONG NGUYEN, (U.S. CLS. 6, 18, 44, 46, 51 AND 52). SN 85-400,226. PUB. 1-10-2012. FILED 8-17-2011.
- 4,118,674. **KORDIAL NUTRIENTS AND DESIGN**. PROGRESSIVE LABORATORIES, INC., DBA KORDIAL NUTRIENTS, (U.S. CLS. 6, 18, 44, 46, 51 AND 52). SN 85-402,097. PUB. 1-10-2012. FILED 8-19-2011.
- 4,118,697. **CERTIFIED QUALITY AÇAVIE PREMIUM AÇAI AND DESIGN**. MONAVIE LLC, (U.S. CLS. 6, 18, 44, 46, 51 AND 52). SN 85-420,768. PUB. 1-10-2012. FILED 9-12-2011.
- 4,118,714. **HELMQUAT (STANDARD CHARACTER)**. HELM AGRO US, INC., (U.S. CLS. 6, 18, 44, 46, 51 AND 52). SN 85-434,120. PUB. 1-10-2012. FILED 9-28-2011.
- 4,118,719. **POLYCID (STANDARD CHARACTER)**. POLYMEDIX, INC., (U.S. CLS. 6, 18, 44, 46, 51 AND 52). SN 85-438,721. PUB. 1-10-2012. FILED 10-4-2011.

CLASS 6—METAL GOODS

- 4,116,557. **LOUISIANA ELECTRIC RIG SERVICE (STANDARD CHARACTER)**. GES GLOBAL ENERGY SERVICES, INC., MULTIPLE CLASS, (INT. CLS. 6 AND 9), (U.S. CLS. 2, 12, 13, 14, 21, 23, 25, 26, 36, 38 AND 50). SN 76-701,177. PUB. 1-10-2012. FILED 1-13-2010.
- 4,116,655. **ADMIRAL SERIES (STANDARD CHARACTER)**. ATLAS MANUFACTURING, INC., (U.S. CLS. 2, 12, 13, 14, 23, 25 AND 50). SN 77-919,298. PUB. 1-10-2012. FILED 1-25-2010.
- 4,116,678 (*See Class 1 for this trademark*).
- 4,116,683. **TRUSTSEAL (STANDARD CHARACTER)**. OVD KINEGRAM AG, MULTIPLE CLASS, (INT. CLS. 6, 9, 16 AND 20), (U.S. CLS. 2, 5, 12, 13, 14, 21, 22, 23, 25, 26, 29, 32, 36, 37, 38 AND 50). SN 79-077,965. PUB. 1-10-2012. FILED 11-19-2009.
- 4,116,687. **ASTER (STANDARD CHARACTER)**. BLANC AERO INDUSTRIES, (U.S. CLS. 2, 12, 13, 14, 23, 25 AND 50). SN 79-079,187. PUB. 1-10-2012. FILED 12-14-2009.
- 4,116,708. **DORIS (STYLIZED)**. DORIS ENGINEERING, MULTIPLE CLASS, (INT. CLS. 6 AND 42), (U.S. CLS. 2, 12, 13, 14, 23, 25, 50, 100 AND 101). SN 79-087,801. PUB. 1-10-2012. FILED 7-29-2010.
- 4,116,728. **1052 - HPS (STANDARD CHARACTER)**. HYDRO ALUMINIUM DEUTSCHLAND GMBH, (U.S. CLS. 2, 12, 13, 14, 23, 25 AND 50). SN 79-092,827. PUB. 1-10-2012. FILED 11-23-2010.
- 4,116,809. **TCHERNOAUDIO CABLE AND DESIGN**. OBCHTCHESTVO S OGRANITCHENNOI OTVETSTVENNOSTYOU "TCHERNOV AODUDIO", MULTIPLE CLASS, (INT. CLS. 6, 9 AND 35), (U.S. CLS. 2, 12, 13, 14, 21, 23, 25, 26, 36, 38, 50, 100, 101 AND 102). SN 79-099,060. PUB. 1-10-2012. FILED 3-4-2011.
- 4,116,811. **MISCELLANEOUS DESIGN**. GUTMANN AG, MULTIPLE CLASS, (INT. CLS. 6, 17 AND 19), (U.S. CLS.

- 1, 2, 5, 12, 13, 14, 23, 25, 33, 35 AND 50). SN 79-099,229. PUB. 1-10-2012. FILED 4-28-2011.
- 4,116,812. **MISCELLANEOUS DESIGN**. BLANC AERO INDUSTRIES, MULTIPLE CLASS, (INT. CLS. 6, 7, 8, 9 AND 20), (U.S. CLS. 2, 12, 13, 14, 19, 21, 22, 23, 25, 26, 28, 31, 32, 34, 35, 36, 38, 44 AND 50). SN 79-099,366. PUB. 1-10-2012. FILED 4-5-2011.
- 4,116,818. **S-IN MOTION (STANDARD CHARACTER)**. ARCELORMITTAL FLAT CARBON EUROPE SA, MULTIPLE CLASS, (INT. CLS. 6, 12 AND 40), (U.S. CLS. 2, 12, 13, 14, 19, 21, 23, 25, 31, 35, 44, 50, 100, 103 AND 106). SN 79-099,597. PUB. 1-10-2012. FILED 4-21-2011.
- 4,116,821. **DANI BIKE (STANDARD CHARACTER)**. DAN TAIEB, MULTIPLE CLASS, (INT. CLS. 6 AND 14), (U.S. CLS. 2, 12, 13, 14, 23, 25, 27, 28 AND 50). SN 79-099,809. PUB. 1-10-2012. FILED 5-23-2011.
- 4,116,826. **BLACK AND DESIGN**. ENAYET PATEL, MULTIPLE CLASS, (INT. CLS. 6, 9, 18 AND 25), (U.S. CLS. 1, 2, 3, 12, 13, 14, 21, 22, 23, 25, 26, 36, 38, 39, 41 AND 50). SN 79-100,176. PUB. 1-10-2012. FILED 4-18-2011.
- 4,116,829. **GENERICA (STANDARD CHARACTER)**. GENERICA GMBH, MULTIPLE CLASS, (INT. CLS. 6, 7 AND 35), (U.S. CLS. 2, 12, 13, 14, 19, 21, 23, 25, 31, 34, 35, 50, 100, 101 AND 102). SN 79-100,396. PUB. 1-10-2012. FILED 6-20-2011.
- 4,116,843. **BI-STAR (STANDARD CHARACTER)**. BOEHRINGER INGELHEIM PHARMA GMBH & CO. GMBH, MULTIPLE CLASS, (INT. CLS. 6 AND 39), (U.S. CLS. 2, 12, 13, 14, 23, 25, 50, 100 AND 105). SN 79-100,841. PUB. 1-10-2012. FILED 6-1-2011.
- 4,116,872. **FLEXWELL (STYLIZED)**. BRUGG ROHR AG, HOLDING, (U.S. CLS. 2, 12, 13, 14, 23, 25 AND 50). SN 79-104,677. PUB. 1-10-2012. FILED 9-13-2011.
- 4,116,917. **NOKOMIS (STANDARD CHARACTER)**. ANTOFAGASTA MINERALS S.A., (U.S. CLS. 2, 12, 13, 14, 23, 25 AND 50). SN 85-094,196. PUB. 1-10-2012. FILED 7-27-2010.
- 4,117,010. **SPRIANO (STYLIZED)**. SPRIANO FLUID MECHANICS S.R.L., MULTIPLE CLASS, (INT. CLS. 6 AND 9), (U.S. CLS. 2, 12, 13, 14, 21, 23, 25, 26, 36, 38 AND 50). SN 85-194,273. PUB. 1-10-2012. FILED 12-9-2010.
- 4,117,048. **HISARNA (STANDARD CHARACTER)**. TECHNOLOGICAL RESOURCES PTY. LIMITED, MULTIPLE CLASS, (INT. CLS. 6 AND 11), (U.S. CLS. 2, 12, 13, 14, 21, 23, 25, 31, 34 AND 50). SN 85-214,467. PUB. 1-10-2012. FILED 1-10-2011.
- 4,117,066. **TRU-FIT FASTENERS (STANDARD CHARACTER)**. STEIER, RODNEY, (U.S. CLS. 2, 12, 13, 14, 23, 25 AND 50). SN 85-220,569. PUB. 1-10-2012. FILED 1-19-2011.
- 4,117,230. **HILLS-MCCANNA (STANDARD CHARACTER)**. HILLS-MCCANNA, LLC, (U.S. CLS. 2, 12, 13, 14, 23, 25 AND 50). SN 85-245,704. PUB. 1-10-2012. FILED 2-18-2011.
- 4,117,687. **HIGH BALL (STANDARD CHARACTER)**. SHERRILL, INC., (U.S. CLS. 2, 12, 13, 14, 23, 25 AND 50). SN 85-341,804. PUB. 1-10-2012. FILED 6-9-2011.
- 4,117,812. **CONCEALED OUTDOORS (STANDARD CHARACTER)**. CONCEALED OUTDOORS, LLC, (U.S. CLS. 2, 12, 13, 14, 23, 25 AND 50). SN 85-359,409. PUB. 1-10-2012. FILED 6-29-2011.
- 4,117,858. **STUDIO COLLECTION (STANDARD CHARACTER)**. SARGENT MANUFACTURING COMPANY, (U.S. CLS. 2, 12, 13, 14, 23, 25 AND 50). SN 85-364,945. PUB. 1-10-2012. FILED 7-7-2011.
- 4,117,860. **KASTALON (STANDARD CHARACTER)**. KASTALON, INC., MULTIPLE CLASS, (INT. CLS. 6 AND 7), (U.S. CLS. 2, 12, 13, 14, 19, 21, 23, 25, 31, 34, 35 AND 50). SN 85-365,035. PUB. 1-10-2012. FILED 7-7-2011.
- 4,117,882. **TIMBER TUFF (STANDARD CHARACTER)**. TRI GLOBAL ENTERPRISES, INC., MULTIPLE CLASS, (INT. CLS. 6, 7, 8, 9 AND 20), (U.S. CLS. 2, 12, 13, 14, 19, 21, 22, 23, 25, 26, 28, 31, 32, 34, 35, 36, 38, 44 AND 50). SN 85-366,330. PUB. 1-10-2012. FILED 7-8-2011.
- 4,118,294 (*See Class 3 for this trademark*).
- 4,118,547. **WIND-LOK (STANDARD CHARACTER)**. ATAS INTERNATIONAL, INC., (U.S. CLS. 2, 12, 13, 14, 23, 25 AND 50). SN 85-395,178. PUB. 1-10-2012. FILED 8-11-2011.
- 4,118,730. **VP AND DESIGN**. PARRISH ENTERPRISES, LTD., (U.S. CLS. 2, 12, 13, 14, 23, 25 AND 50). SN 85-451,852. PUB. 1-10-2012. FILED 10-20-2011.

CLASS 7—MACHINERY

- 4,116,650. **LIFE'S GOOD, WHEN IT'S GREEN (STANDARD CHARACTER)**. LG ELECTRONICS INC., MULTIPLE CLASS, (INT. CLS. 7, 9, 10, 11, 35 AND 38), (U.S. CLS. 13, 19, 21, 23, 26, 31, 34, 35, 36, 38, 39, 44, 100, 101, 102 AND 104). SN 77-917,093. PUB. 1-10-2012. FILED 1-21-2010.
- 4,116,651. **RE RECYCLABILITY IMPROVEMENT AND DESIGN**. LG ELECTRONICS INC., MULTIPLE CLASS, (INT. CLS. 7, 9, 10, 11, 35 AND 38), (U.S. CLS. 13, 19, 21, 23, 26, 31, 34, 35, 36, 38, 39, 44, 100, 101, 102 AND 104). SN 77-918,164. PUB. 1-10-2012. FILED 1-22-2010.
- 4,116,652. **HAZARDOUS SUBSTANCES REDUCTION AND DESIGN**. LG ELECTRONICS INC., MULTIPLE CLASS, (INT. CLS. 7, 9, 10, 11, 35 AND 38), (U.S. CLS. 13, 19, 21, 23, 26, 31, 34, 35, 36, 38, 39, 44, 100, 101, 102 AND 104). SN 77-918,225. PUB. 1-10-2012. FILED 1-22-2010.
- 4,116,653. **PACKAGING AND DESIGN**. LG ELECTRONICS INC., MULTIPLE CLASS, (INT. CLS. 7, 9, 10, 11, 35 AND 38), (U.S. CLS. 13, 19, 21, 23, 26, 31, 34, 35, 36, 38, 39, 44, 100, 101, 102 AND 104). SN 77-918,280. PUB. 1-10-2012. FILED 1-22-2010.
- 4,116,678 (*See Class 1 for this trademark*).
- 4,116,682. **GRID STREAMER (STANDARD CHARACTER)**. VESTAS WIND SYSTEMS A/S, MULTIPLE CLASS, (INT. CLS. 7, 9 AND 37), (U.S. CLS. 13, 19, 21, 23, 26, 31, 34, 35, 36, 38, 100, 103 AND 106). SN 79-077,852. PUB. 1-10-2012. FILED 10-27-2009.
- 4,116,688. **LQ GROUP (STYLIZED)**. LQ MECHATRONIK-SYSTEME GMBH, MULTIPLE CLASS, (INT. CLS. 7, 9, 17, 37, 38 AND 42), (U.S. CLS. 1, 5, 12, 13, 19, 21, 23, 26, 31, 34, 35, 36, 38, 50, 100, 101, 103, 104 AND 106). SN 79-082,116. PUB. 1-10-2012. FILED 12-30-2009.
- 4,116,727. **TAI GOLD STONE AND DESIGN**. JINAN XINLEI PRECISION MACHINERY CO., LTD., MULTIPLE CLASS, (INT. CLS. 7, 9 AND 19), (U.S. CLS. 1, 12, 13, 19, 21, 23, 26, 31, 33, 34, 35, 36, 38 AND 50). SN 79-092,635. PUB. 1-10-2012. FILED 12-29-2010.
- 4,116,752. **IHC MERWEDE (STANDARD CHARACTER)**. IHC HOLLAND IE B.V., MULTIPLE CLASS, (INT. CLS. 7 AND 12), (U.S. CLS. 13, 19, 21, 23, 31, 34, 35 AND 44). SN 79-095,375. PUB. 1-10-2012. FILED 11-11-2010.
- 4,116,753. **HISHAFT MAINA ORGANI DI TRASMISSIONE ASTI - ITALY AND DESIGN**. MAINA ORGANI DI TRASMISSIONE S.P.A., (U.S. CLS. 13, 19, 21, 23, 31, 34 AND 35). SN 79-095,379. PUB. 1-10-2012. FILED 1-5-2011.
- 4,116,756. **ADFOOD ADVANCED FOOD SYSTEMS AND DESIGN**. LIEN INICIATIVES EMPRESARIALS I NEGOCIS, S.L., (U.S. CLS. 13, 19, 21, 23, 31, 34 AND 35). SN 79-095,718. PUB. 1-10-2012. FILED 1-25-2011.
- 4,116,761. **SCHWARMSTROM (STANDARD CHARACTER)**. LICHTBLICK AG, MULTIPLE CLASS, (INT. CLS. 7, 9, 11, 12, 35, 36, 37, 38, 39, 40 AND 42), (U.S. CLS. 13, 19, 21, 23, 26, 31, 34, 35, 36, 38, 44, 100, 101, 102, 103, 104, 105 AND 106). SN 79-095,845. PUB. 1-10-2012. FILED 2-15-2010.
- 4,116,774. **SCHINDLER 5500 (STANDARD CHARACTER)**. INVENTIO AG, MULTIPLE CLASS, (INT. CLS. 7, 9 AND 37), (U.S. CLS. 13, 19, 21, 23, 26, 31, 34, 35, 36, 38, 100, 103 AND 106). SN 79-096,292. PUB. 1-10-2012. FILED 3-17-2011.
- 4,116,781. **LEPONO AND DESIGN**. ZHEJIANG LEO CO., LTD., (U.S. CLS. 13, 19, 21, 23, 31, 34 AND 35). SN 79-096,739. PUB. 1-10-2012. FILED 3-17-2011.
- 4,116,784. **LMT AND DESIGN**. LMT GMBH & CO. KG, (U.S. CLS. 13, 19, 21, 23, 31, 34 AND 35). SN 79-097,190. PUB. 1-10-2012. FILED 12-21-2010.
- 4,116,787. **E AND DESIGN**. EPOKE A/S, MULTIPLE CLASS, (INT. CLS. 7 AND 9), (U.S. CLS. 13, 19, 21, 23, 26, 31, 34, 35, 36 AND 38). SN 79-097,365. PUB. 1-10-2012. FILED 3-18-2011.
- 4,116,812 (*See Class 6 for this trademark*).
- 4,116,819. **PASABAN AND DESIGN**. PASABAN, S.A., MULTIPLE CLASS, (INT. CLS. 7 AND 37), (U.S. CLS. 13, 19, 21, 23, 31, 34, 35, 100, 103 AND 106). SN 79-099,666. PUB. 1-10-2012. FILED 5-11-2011.
- 4,116,829 (*See Class 6 for this trademark*).
- 4,116,841. **DIFGEN (STANDARD CHARACTER)**. ENERGREEN AS, MULTIPLE CLASS, (INT. CLS. 7 AND 11), (U.S. CLS. 13, 19, 21, 23, 31, 34 AND 35). SN 79-100,784. PUB. 1-10-2012. FILED 4-4-2011.
- 4,116,857. **DIABLO (STANDARD CHARACTER)**. METSO

- LINDEMANN GMBH, (U.S. CLS. 13, 19, 21, 23, 31, 34 AND 35). SN 79-102,160. PUB. 1-10-2012. FILED 5-3-2010.
- 4,116,865. **ZSG (STANDARD CHARACTER)**. HITOP (XIAMEN) MECHANICAL INDUSTRY CO., LTD., MULTIPLE CLASS, (INT. CLS. 7 AND 12), (U.S. CLS. 13, 19, 21, 23, 31, 34, 35 AND 44). SN 79-103,352. PUB. 1-10-2012. FILED 8-2-2011.
- 4,116,866. **MIASEN (STYLIZED)**. ZHEJIANG MIASEN ELECTRIC APPARATUS CO., LTD., MULTIPLE CLASS, (INT. CLS. 7 AND 9), (U.S. CLS. 13, 19, 21, 23, 26, 31, 34, 35, 36 AND 38). SN 79-103,650. PUB. 1-10-2012. FILED 11-24-2010.
- 4,116,875. **LINEDRIVER (STANDARD CHARACTER)**. GRACO MINNESOTA INC., (U.S. CLS. 13, 19, 21, 23, 31, 34 AND 35). SN 85-003,234. PUB. 1-10-2012. FILED 3-31-2010.
- 4,116,929. **THE POWERSTACK (STANDARD CHARACTER)**. 1444555 ALBERTA LTD., DBA 45 INNOVATIONS, (U.S. CLS. 13, 19, 21, 23, 31, 34 AND 35). SN 85-101,278. PUB. 1-10-2012. FILED 8-5-2010.
- 4,116,988. **MISCELLANEOUS DESIGN**. CTB, INC., (U.S. CLS. 13, 19, 21, 23, 31, 34 AND 35). SN 85-180,347. PUB. 1-10-2012. FILED 11-18-2010.
- 4,117,073. **HEYANG AND DESIGN**. INCODEL CORPORATION, (U.S. CLS. 13, 19, 21, 23, 31, 34 AND 35). SN 85-221,411. PUB. 1-10-2012. FILED 1-19-2011.
- 4,117,083. **HE YANG AND DESIGN**. INCODEL CORPORATION, (U.S. CLS. 13, 19, 21, 23, 31, 34 AND 35). SN 85-223,093. PUB. 1-10-2012. FILED 1-21-2011.
- 4,117,086. **ZYNP AND DESIGN**. INCODEL CORPORATION, (U.S. CLS. 13, 19, 21, 23, 31, 34 AND 35). SN 85-223,345. PUB. 1-10-2012. FILED 1-21-2011.
- 4,117,123. **DRIVEN DIESEL (STANDARD CHARACTER)**. SCHROEDER, DENNIS, (U.S. CLS. 13, 19, 21, 23, 31, 34 AND 35). SN 85-230,834. PUB. 1-10-2012. FILED 2-1-2011.
- 4,117,179. **ZLI (STANDARD CHARACTER)**. GENERAL MOTORS LLC, (U.S. CLS. 13, 19, 21, 23, 31, 34 AND 35). SN 85-237,470. PUB. 1-10-2012. FILED 2-9-2011.
- 4,117,272. **MR. BLENDER AND DESIGN**. MICHAEL E. MURPHY, MULTIPLE CLASS, (INT. CLS. 7, 16 AND 32), (U.S. CLS. 2, 5, 13, 19, 21, 22, 23, 29, 31, 34, 35, 37, 38, 45, 46, 48 AND 50). SN 85-255,102. PUB. 1-10-2012. FILED 3-1-2011.
- 4,117,273. **TUFFLOCK (STANDARD CHARACTER)**. CQMS PTY LTD, (U.S. CLS. 13, 19, 21, 23, 31, 34 AND 35). SN 85-255,155. PUB. 1-10-2012. FILED 3-1-2011.
- 4,117,302. **RESILIENCE AND DESIGN**. GLORY HOLDING LIMITED, (U.S. CLS. 13, 19, 21, 23, 31, 34 AND 35). SN 85-260,413. PUB. 1-10-2012. FILED 3-7-2011.
- 4,117,420. **TIGER (STANDARD CHARACTER)**. WOLO MANUFACTURING CORP., (U.S. CLS. 13, 19, 21, 23, 31, 34 AND 35). SN 85-286,878. PUB. 1-10-2012. FILED 4-5-2011.
- 4,117,442. **BUSATIS RED KNIVES (STANDARD CHARACTER)**. GEBRÜDER BUSATIS GESELLSCHAFT M.B.H., (U.S. CLS. 13, 19, 21, 23, 31, 34 AND 35). SN 85-291,685. PUB. 1-10-2012. FILED 4-11-2011.
- 4,117,600. **TRUSTY WARNS (STANDARD CHARACTER)**. TRUSTY WARNS, INC., MULTIPLE CLASS, (INT. CLS. 7 AND 37), (U.S. CLS. 13, 19, 21, 23, 31, 34, 35, 100, 103 AND 106). SN 85-324,211. PUB. 1-10-2012. FILED 5-18-2011.
- 4,117,651. **KOLDFRONT AND DESIGN**. LIVING DIRECT, INC., MULTIPLE CLASS, (INT. CLS. 7 AND 11), (U.S. CLS. 13, 19, 21, 23, 31, 34 AND 35). SN 85-333,687. PUB. 1-10-2012. FILED 5-31-2011.
- 4,117,713. **FÜGGENTUFFER AND DESIGN**. J.D. NEUHAUS LIMITED PARTNERSHIP, (U.S. CLS. 13, 19, 21, 23, 31, 34 AND 35). SN 85-346,854. PUB. 1-10-2012. FILED 6-15-2011.
- 4,117,737. **L AND DESIGN**. LIANG CHI INDUSTRY CO., LTD., (U.S. CLS. 13, 19, 21, 23, 31, 34 AND 35). SN 85-350,029. PUB. 1-10-2012. FILED 6-19-2011.
- 4,117,860 (*See Class 6 for this trademark*).
- 4,117,882 (*See Class 6 for this trademark*).
- 4,118,150. **POWERLINE AND DESIGN**. D&S EXPORTS, INC., (U.S. CLS. 13, 19, 21, 23, 31, 34 AND 35). SN 85-375,356. PUB. 1-10-2012. FILED 7-19-2011.
- 4,118,469. **GEOVOLT (STANDARD CHARACTER)**. GEOTRICITY, LLC, (U.S. CLS. 13, 19, 21, 23, 31, 34 AND 35). SN 85-393,501. PUB. 1-10-2012. FILED 8-9-2011.
- 4,118,566. **ELSCO (STANDARD CHARACTER)**. ELEVATOR SAFETY COMPANY, AKA ELSKO, (U.S. CLS. 13, 19, 21, 23, 31, 34 AND 35). SN 85-395,547. PUB. 1-10-2012. FILED 8-11-2011.
- 4,118,585. **NANOFLO (STANDARD CHARACTER)**. MOMENTUM DISTRIBUTION CORP., DBA AIR STRATEGIES, (U.S. CLS. 13, 19, 21, 23, 31, 34 AND 35). SN 85-395,856. PUB. 1-10-2012. FILED 8-11-2011.
- 4,118,595. **NANOFLO AND DESIGN**. MOMENTUM DISTRIBUTION CORP., DBA AIR STRATEGIES, (U.S. CLS. 13, 19, 21, 23, 31, 34 AND 35). SN 85-396,041. PUB. 1-10-2012. FILED 8-11-2011.
- 4,118,600. **DLE AND DESIGN**. DONG LING, (U.S. CLS. 13, 19, 21, 23, 31, 34 AND 35). SN 85-396,104. PUB. 1-10-2012. FILED 8-12-2011.
- 4,118,645. **POWERFORMER AND DESIGN**. CHONGQING YINXIANG XIAOXING GENERAL MACHINERY CO., LTD., (U.S. CLS. 13, 19, 21, 23, 31, 34 AND 35). SN 85-397,070. PUB. 1-10-2012. FILED 8-12-2011.
- 4,118,649. **POWERATOR (STYLIZED)**. CHONGQING YINXIANG XIAOXING GENERAL MACHINERY CO., LTD., (U.S. CLS. 13, 19, 21, 23, 31, 34 AND 35). SN 85-397,114. PUB. 1-10-2012. FILED 8-12-2011.
- 4,118,702. **H HAYWARD AND DESIGN**. HAYWARD INDUSTRIES, INC., MULTIPLE CLASS, (INT. CLS. 7, 9 AND 11), (U.S. CLS. 13, 19, 21, 23, 26, 31, 34, 35, 36 AND 38). SN 85-426,009. PUB. 1-10-2012. FILED 9-19-2011.

CLASS 8—HAND TOOLS

- 4,116,566 (*See Class 3 for this trademark*).
- 4,116,585. **PROJECT PARTNERS (STANDARD CHARACTER)**. AWI ACQUISITION COMPANY, MULTIPLE CLASS, (INT. CLS. 8, 11 AND 16), (U.S. CLS. 2, 5, 13, 21, 22, 23, 28, 29, 31, 34, 37, 38, 44 AND 50). SN 76-708,428. PUB. 1-10-2012. FILED 7-21-2011.
- 4,116,587. **MAX TORQUE (STANDARD CHARACTER)**. AWI ACQUISITION COMPANY, (U.S. CLS. 23, 28 AND 44). SN 76-709,067. PUB. 1-10-2012. FILED 9-14-2011.
- 4,116,674. **FLEXIMARK (STANDARD CHARACTER)**. LAPP ENGINEERING & CO., MULTIPLE CLASS, (INT. CLS. 8, 9 AND 16), (U.S. CLS. 2, 5, 21, 22, 23, 26, 28, 29, 36, 37, 38, 44 AND 50). SN 79-036,400. PUB. 1-10-2012. FILED 11-20-2006.
- 4,116,703. **GELERT OUTDOORS SINCE 1975 AND DESIGN**. GELERT LTD, MULTIPLE CLASS, (INT. CLS. 8, 9, 11, 18, 20, 21, 22, 25 AND 35), (U.S. CLS. 1, 2, 3, 7, 13, 19, 21, 22, 23, 25, 26, 28, 29, 30, 31, 32, 33, 34, 36, 38, 39, 40, 41, 42, 44, 50, 100, 101 AND 102). SN 79-086,760. PUB. 1-10-2012. FILED 7-1-2010.
- 4,116,707. **HELLO DARL HOME EVENTS AND DESIGN**. HOME EVENTS PTY LIMITED, MULTIPLE CLASS, (INT. CLS. 8, 16, 18, 20 AND 25), (U.S. CLS. 1, 2, 3, 5, 13, 22, 23, 25, 28, 29, 32, 37, 38, 39, 41, 44 AND 50). SN 79-087,698. PUB. 1-10-2012. FILED 6-24-2010.
- 4,116,812 (*See Class 6 for this trademark*).
- 4,117,019. **STEEL WARRIOR AND DESIGN**. FROST CUTLERY COMPANY LLC, (U.S. CLS. 23, 28 AND 44). SN 85-199,852. PUB. 1-10-2012. FILED 12-16-2010.
- 4,117,160. **H H HEISER (STANDARD CHARACTER)**. THE SHARPS RIFLE COMPANY, LLC, FORMERLY MHB ENTERPRISES, MULTIPLE CLASS, (INT. CLS. 8 AND 13), (U.S. CLS. 2, 9, 23, 28 AND 44). SN 85-235,492. PUB. 1-10-2012. FILED 2-7-2011.
- 4,117,231. **SHARPNEASY (STYLIZED)**. FORTUNE PRODUCTS, INC., (U.S. CLS. 23, 28 AND 44). SN 85-246,169. PUB. 1-10-2012. FILED 2-18-2011.
- 4,117,366. **GREEN WITH ENVY (STANDARD CHARACTER)**. THE TJX COMPANIES, INC., (U.S. CLS. 23, 28 AND 44). SN 85-275,290. PUB. 1-10-2012. FILED 3-24-2011.
- 4,117,577. **INDUSTRIAL FORGE AND DESIGN**. MASTER CRAFT PRODUCTS CORP., (U.S. CLS. 23, 28 AND 44). SN 85-320,430. PUB. 1-10-2012. FILED 5-13-2011.
- 4,117,882 (*See Class 6 for this trademark*).
- 4,117,956. **THE RESINATOR AND DESIGN**. NEPTUNE RESEARCH, INC., (U.S. CLS. 23, 28 AND 44). SN 85-370,187. PUB. 1-10-2012. FILED 7-13-2011.
- 4,117,991. **WHITTLIN' JACK (STANDARD CHARACTER)**. FLEXCUT TOOL COMPANY, INC., (U.S. CLS. 23, 28 AND 44). SN 85-371,336. PUB. 1-10-2012. FILED 7-14-2011.

- 4,118,142. **CARVIN' JACK (STANDARD CHARACTER)**. FLEXCUT TOOL COMPANY, INC. (U.S. CLS. 23, 28 AND 44). SN 85-375,285. PUB. 1-10-2012. FILED 7-19-2011.
- 4,118,170. **POCKET JACK (STANDARD CHARACTER)**. FLEXCUT TOOL COMPANY, INC. (U.S. CLS. 23, 28 AND 44). SN 85-375,627. PUB. 1-10-2012. FILED 7-19-2011.
- 4,118,171. **FLEXCUT (STANDARD CHARACTER)**. FLEXCUT TOOL COMPANY, INC., (U.S. CLS. 23, 28 AND 44). SN 85-375,644. PUB. 1-10-2012. FILED 7-19-2011.

CLASS 9—ELECTRICAL AND SCIENTIFIC APPARATUS

- 4,116,557 (*See Class 6 for this trademark.*)
- 4,116,561. **ALICE IN WONDERLAND (STANDARD CHARACTER)**. DISNEY ENTERPRISES, INC., (U.S. CLS. 21, 23, 26, 36 AND 38). SN 76-704,398. PUB. 1-10-2012. FILED 9-7-2010.
- 4,116,573. **BLACKRIDGE TECHNOLOGY (STANDARD CHARACTER)**. BLACKRIDGE TECHNOLOGY HOLDINGS, INC., MULTIPLE CLASS, (INT. CLS. 9 AND 42), (U.S. CLS. 21, 23, 26, 36, 38, 100 AND 101). SN 76-707,560. PUB. 1-10-2012. FILED 5-10-2011.
- 4,116,574. **BLACKRIDGE TECHNOLOGY AND DESIGN**. BLACKRIDGE TECHNOLOGY HOLDINGS, INC., MULTIPLE CLASS, (INT. CLS. 9 AND 42), (U.S. CLS. 21, 23, 26, 36, 38, 100 AND 101). SN 76-707,561. PUB. 1-10-2012. FILED 5-10-2011.
- 4,116,593. **LITTLE MISS CHATTERBOX AND DESIGN**. THOIP, MULTIPLE CLASS, (INT. CLS. 9, 16, 25, 28 AND 41), (U.S. CLS. 2, 5, 21, 22, 23, 26, 29, 36, 37, 38, 39, 50, 100, 101 AND 107). SN 77-280,364. PUB. 11-23-2010. FILED 9-14-2007.
- 4,116,597. **IFLEX (STANDARD CHARACTER)**. KIMBERLY-CLARK WORLDWIDE, INC., (U.S. CLS. 21, 23, 26, 36 AND 38). SN 77-378,692. PUB. 1-10-2012. FILED 1-23-2008.
- 4,116,602. **6 LEGS AND DESIGN**. BRAD PATTISON ENTERTAINMENT CORPORATION, MULTIPLE CLASS, (INT. CLS. 9, 18, 20, 21, 25 AND 41), (U.S. CLS. 1, 2, 3, 13, 21, 22, 23, 25, 26, 29, 30, 32, 33, 36, 38, 39, 40, 41, 50, 100, 101 AND 107). SN 77-500,971. PUB. 1-10-2012. FILED 6-17-2008.
- 4,116,605. **MANSION PRODUCTIONS (STANDARD CHARACTER)**. MANSION PRODUCTIONS, LLC, DBA MANSION PRODUCTIONS, INC., MULTIPLE CLASS, (INT. CLS. 9, 35 AND 42), (U.S. CLS. 21, 23, 26, 36, 38, 100, 101 AND 102). SN 77-536,505. PUB. 1-10-2012. FILED 7-31-2008.
- 4,116,606. **SIN (STANDARD CHARACTER)**. SHABLOW, KIRK, MULTIPLE CLASS, (INT. CLS. 9, 16 AND 41), (U.S. CLS. 2, 5, 21, 22, 23, 26, 29, 36, 37, 38, 50, 100, 101 AND 107). SN 77-607,342. PUB. 10-4-2011. FILED 11-4-2008.
- 4,116,611. **KURUMAME (STANDARD CHARACTER)**. KAYABA INDUSTRY CO., LTD., AKA KAYABA KOGYO KABUSHIKI KAISHA, MULTIPLE CLASS, (INT. CLS. 9 AND 37), (U.S. CLS. 21, 23, 26, 36, 38, 100, 103 AND 106). SN 77-713,119. PUB. 1-10-2012. FILED 4-14-2009.
- 4,116,620. **GRYPHON (STANDARD CHARACTER)**. DATALOGIC SCANNING, INC., (U.S. CLS. 21, 23, 26, 36 AND 38). SN 77-770,009. PUB. 1-10-2012. FILED 6-29-2009.
- 4,116,622. **MISCELLANEOUS DESIGN**. SPORT HELMETS INC., (U.S. CLS. 21, 23, 26, 36 AND 38). SN 77-788,722. PUB. 1-10-2012. FILED 7-24-2009.
- 4,116,623. **MISCELLANEOUS DESIGN**. SPORT HELMETS INC., (U.S. CLS. 21, 23, 26, 36 AND 38). SN 77-788,757. PUB. 1-10-2012. FILED 7-24-2009.
- 4,116,624. **MISCELLANEOUS DESIGN**. SPORT HELMETS INC., (U.S. CLS. 21, 23, 26, 36 AND 38). SN 77-788,875. PUB. 1-10-2012. FILED 7-24-2009.
- 4,116,625. **MISCELLANEOUS DESIGN**. SPORT HELMETS INC., (U.S. CLS. 21, 23, 26, 36 AND 38). SN 77-788,908. PUB. 1-10-2012. FILED 7-24-2009.
- 4,116,626. **MISCELLANEOUS DESIGN**. SPORT HELMETS INC., (U.S. CLS. 21, 23, 26, 36 AND 38). SN 77-788,929. PUB. 1-10-2012. FILED 7-24-2009.
- 4,116,636. **IQ ROUTES (STANDARD CHARACTER)**. TOMTOM INTERNATIONAL B.V., MULTIPLE CLASS, (INT. CLS. 9, 39 AND 42), (U.S. CLS. 21, 23, 26, 36, 38, 100, 101 AND 105). SN 77-843,350. PUB. 1-10-2012. FILED 10-7-2009.
- 4,116,650 (*See Class 7 for this trademark.*)
- 4,116,651 (*See Class 7 for this trademark.*)
- 4,116,652 (*See Class 7 for this trademark.*)
- 4,116,653 (*See Class 7 for this trademark.*)
- 4,116,654. **IOP TECHNOLOGY AND DESIGN**. LG ELECTRONICS INC., (U.S. CLS. 21, 23, 26, 36 AND 38). SN 77-919,242. PUB. 1-10-2012. FILED 1-25-2010.
- 4,116,661. **SIMCHECK (STANDARD CHARACTER)**. HO, WAI YAN, (U.S. CLS. 21, 23, 26, 36 AND 38). SN 77-933,244. PUB. 1-10-2012. FILED 2-11-2010.
- 4,116,662. **HPDA (STANDARD CHARACTER)**. HO, WAI YAN, (U.S. CLS. 21, 23, 26, 36 AND 38). SN 77-939,623. PUB. 1-10-2012. FILED 2-19-2010.
- 4,116,674 (*See Class 8 for this trademark.*)
- 4,116,678 (*See Class 1 for this trademark.*)
- 4,116,679. **OPENLR (STANDARD CHARACTER)**. TOMTOM INTERNATIONAL B.V., MULTIPLE CLASS, (INT. CLS. 9, 38 AND 39), (U.S. CLS. 21, 23, 26, 36, 38, 100, 101, 104 AND 105). SN 79-074,527. PUB. 1-10-2012. FILED 8-27-2009.
- 4,116,681. **GOLDEN SKATE AWARDS AND DESIGN**. RIP-TIDE S.R.L., MULTIPLE CLASS, (INT. CLS. 9, 16, 25, 35, 38 AND 41), (U.S. CLS. 2, 5, 21, 22, 23, 26, 29, 36, 37, 38, 39, 50, 100, 101, 102, 104 AND 107). SN 79-077,436. PUB. 1-10-2012. FILED 6-23-2009.
- 4,116,682 (*See Class 7 for this trademark.*)
- 4,116,683 (*See Class 6 for this trademark.*)
- 4,116,686. **TNO HELIX (STANDARD CHARACTER)**. NEDERLANDSE ORGANISATIE VOOR TOEGEPAST- NATUURWETENSCHAPPELIJK ONDERZOEK TNO, MULTIPLE CLASS, (INT. CLS. 9 AND 42), (U.S. CLS. 21, 23, 26, 36, 38, 100 AND 101). SN 79-078,323. PUB. 1-10-2012. FILED 1-8-2010.
- 4,116,688 (*See Class 7 for this trademark.*)
- 4,116,696. **WIRE WINDER AND DESIGN**. ATLANTIC PAPER COMPANY "ATCO" B.V., (U.S. CLS. 21, 23, 26, 36 AND 38). SN 79-085,610. PUB. 1-10-2012. FILED 6-14-2010.
- 4,116,697. **MISCELLANEOUS DESIGN**. ZODIAK RIGHTS LIMITED, MULTIPLE CLASS, (INT. CLS. 9, 16, 25, 28, 38 AND 41), (U.S. CLS. 2, 5, 21, 22, 23, 26, 29, 36, 37, 38, 39, 50, 100, 101, 104 AND 107). SN 79-085,712. PUB. 1-10-2012. FILED 4-7-2010.
- 4,116,700. **MAGIC CAPTAIN AND DESIGN**. COSTA RAFAELE, MULTIPLE CLASS, (INT. CLS. 9, 16 AND 41), (U.S. CLS. 2, 5, 21, 22, 23, 26, 29, 36, 37, 38, 50, 100, 101 AND 107). SN 79-086,127. PUB. 1-10-2012. FILED 1-25-2010.
- 4,116,703 (*See Class 8 for this trademark.*)
- 4,116,706 (*See Class 3 for this trademark.*)
- 4,116,713. **HELIWISE AND DESIGN**. AGUSTAWESTLAND S.P.A., MULTIPLE CLASS, (INT. CLS. 9 AND 42), (U.S. CLS. 21, 23, 26, 36, 38, 100 AND 101). SN 79-088,897. PUB. 1-10-2012. FILED 10-4-2010.
- 4,116,719. **MALVERN INSTRUMENTS (STANDARD CHARACTER)**. MALVERN INSTRUMENTS LIMITED, (U.S. CLS. 21, 23, 26, 36 AND 38). SN 79-090,295. PUB. 1-10-2012. FILED 6-11-2010.
- 4,116,724. **MISCELLANEOUS DESIGN**. XPEREDON GROUP SA, MULTIPLE CLASS, (INT. CLS. 9, 36 AND 38), (U.S. CLS. 21, 23, 26, 36, 38, 100, 101, 102 AND 104). SN 79-092,127. PUB. 1-10-2012. FILED 12-9-2010.
- 4,116,727 (*See Class 7 for this trademark.*)
- 4,116,729. **BOOK IN A BOX AND DESIGN**. THE OCTOPUS COMPANY, NAAMLOZE VENNOOTSCHAP, MULTIPLE CLASS, (INT. CLS. 9, 16 AND 36), (U.S. CLS. 2, 5, 21, 22, 23, 26, 29, 36, 37, 38, 50, 100, 101 AND 102). SN 79-093,330. PUB. 1-10-2012. FILED 12-22-2010.
- 4,116,734. **PUMA AND DESIGN**. PUMA SE, (U.S. CLS. 21, 23, 26, 36 AND 38). SN 79-094,216. PUB. 1-10-2012. FILED 1-14-2011.
- 4,116,736. **LOCLIFE SERVICES (STYLIZED)**. ALSTOM TRANSPORT SA, MULTIPLE CLASS, (INT. CLS. 9, 12, 37 AND 39), (U.S. CLS. 19, 21, 23, 26, 31, 35, 36, 38, 44, 100, 103, 105 AND 106). SN 79-094,399. PUB. 1-10-2012. FILED 1-18-2011.
- 4,116,739 (*See Class 1 for this trademark.*)
- 4,116,749. **PAPI (STANDARD CHARACTER)**. CUBIKS INTELLECTUAL PROPERTY LIMITED, (U.S. CLS. 21, 23, 26, 36 AND 38). SN 79-095,198. PUB. 1-10-2012. FILED 2-10-2011.
- 4,116,750. **MEMOSUITE (STANDARD CHARACTER)**. KNICK ELEKTRONISCHE MESSGERÄTE GMBH & CO. KG, (U.S.

- CLS. 21, 23, 26, 36 AND 38). SN 79-095,199. PUB. 1-10-2012. FILED 2-7-2011.
- 4,116,751. **VAGABUNDOS (STYLIZED)**. CADENZA MUSIC SARL, MULTIPLE CLASS, (INT. CLS. 9 AND 41), (U.S. CLS. 21, 23, 26, 36, 38, 100, 101 AND 107). SN 79-095,348. PUB. 1-10-2012. FILED 3-7-2011.
- 4,116,757. **H AND DESIGN**. OZONE COMMUNITY CORPORATION, MULTIPLE CLASS, (INT. CLS. 9, 14, 16, 18, 20, 21, 24, 25, 26, 28 AND 34), (U.S. CLS. 1, 2, 3, 5, 8, 9, 13, 17, 21, 22, 23, 25, 26, 27, 28, 29, 30, 32, 33, 36, 37, 38, 39, 40, 41, 42 AND 50). SN 79-095,719. PUB. 1-10-2012. FILED 12-16-2010.
- 4,116,758. **TENDA (STYLIZED)**. QUAN DENGPIG, (U.S. CLS. 21, 23, 26, 36 AND 38). SN 79-095,799. PUB. 1-10-2012. FILED 2-10-2011.
- 4,116,759. **APRIL SHOWERS (STANDARD CHARACTER)**. BURBERRY LIMITED, MULTIPLE CLASS, (INT. CLS. 9, 14, 18, 25 AND 35), (U.S. CLS. 1, 2, 3, 21, 22, 23, 26, 27, 28, 36, 38, 39, 41, 50, 100, 101 AND 102). SN 79-095,816. PUB. 1-10-2012. FILED 11-8-2010.
- 4,116,760. **NUMENKO (STANDARD CHARACTER)**. TSL ENTERPRISES LIMITED, MULTIPLE CLASS, (INT. CLS. 9 AND 28), (U.S. CLS. 21, 22, 23, 26, 36, 38 AND 50). SN 79-095,823. PUB. 1-10-2012. FILED 12-22-2010.
- 4,116,761 (*See Class 7 for this trademark*).
- 4,116,764. **TRADESIGNAL (STYLIZED)**. TRADESIGNAL GMBH, MULTIPLE CLASS, (INT. CLS. 9, 16, 42 AND 45), (U.S. CLS. 2, 5, 21, 22, 23, 26, 29, 36, 37, 38, 50, 100 AND 101). SN 79-095,941. PUB. 1-10-2012. FILED 5-12-2010.
- 4,116,765. **ENPEVET AND DESIGN**. PLAMBECK HOLDING AG, MULTIPLE CLASS, (INT. CLS. 9 AND 38), (U.S. CLS. 21, 23, 26, 36, 38, 100, 101 AND 104). SN 79-096,031. PUB. 10-4-2011. FILED 2-23-2011.
- 4,116,768 (*See Class 3 for this trademark*).
- 4,116,769. **VKP80III (STYLIZED)**. CUSTOM ENGINEERING S.P.A., (U.S. CLS. 21, 23, 26, 36 AND 38). SN 79-096,198. PUB. 1-10-2012. FILED 2-15-2011.
- 4,116,774 (*See Class 7 for this trademark*).
- 4,116,775. **KASPERSKY LAB AND DESIGN**. KASPERSKY LAB ZAO, MULTIPLE CLASS, (INT. CLS. 9, 16, 35 AND 42), (U.S. CLS. 2, 5, 21, 22, 23, 26, 29, 36, 37, 38, 50, 100, 101 AND 102). SN 79-096,448. PUB. 1-10-2012. FILED 1-20-2011.
- 4,116,778. **OWLED (STANDARD CHARACTER)**. BCD-GMBH, (U.S. CLS. 21, 23, 26, 36 AND 38). SN 79-096,559. PUB. 1-10-2012. FILED 3-24-2011.
- 4,116,780. **HT AND DESIGN**. HT ITALIA S.R.L., (U.S. CLS. 21, 23, 26, 36 AND 38). SN 79-096,635. PUB. 1-10-2012. FILED 1-17-2011.
- 4,116,787 (*See Class 7 for this trademark*).
- 4,116,790. **VIMILL (STANDARD CHARACTER)**. FIDIA S.P.A., (U.S. CLS. 21, 23, 26, 36 AND 38). SN 79-097,616. PUB. 1-10-2012. FILED 4-14-2011.
- 4,116,794. **JCTC TERMINAL & CONNECTORS (STYLIZED)**. DONGGUAN CITY SHENGLAN ELECTRONICS CO., LTD., (U.S. CLS. 21, 23, 26, 36 AND 38). SN 79-097,774. PUB. 1-10-2012. FILED 5-17-2011.
- 4,116,797. **N-SQUARE (STANDARD CHARACTER)**. PARKEON, (U.S. CLS. 21, 23, 26, 36 AND 38). SN 79-097,872. PUB. 1-10-2012. FILED 4-21-2011.
- 4,116,801. **APRICOOL (STYLIZED)**. BRANDDECODE, SOCIÉTÉ PRIVÉE À RESPONSABILITÉ LIMITÉE, MULTIPLE CLASS, (INT. CLS. 9, 35 AND 41), (U.S. CLS. 21, 23, 26, 36, 38, 100, 101, 102 AND 107). SN 79-098,322. PUB. 1-10-2012. FILED 3-22-2011.
- 4,116,809 (*See Class 6 for this trademark*).
- 4,116,812 (*See Class 6 for this trademark*).
- 4,116,815. **XREL SEMICONDUCTOR AND DESIGN**. EASII IC, MULTIPLE CLASS, (INT. CLS. 9, 16 AND 42), (U.S. CLS. 2, 5, 21, 22, 23, 26, 29, 36, 37, 38, 50, 100 AND 101). SN 79-099,472. PUB. 1-10-2012. FILED 5-12-2011.
- 4,116,826 (*See Class 6 for this trademark*).
- 4,116,850. **HAPPY WARS (STANDARD CHARACTER)**. TOY-LOGIC INC., MULTIPLE CLASS, (INT. CLS. 9 AND 41), (U.S. CLS. 21, 23, 26, 36, 38, 100, 101 AND 107). SN 79-101,348. PUB. 1-10-2012. FILED 4-4-2011.
- 4,116,853. **CELLLOCATE (STANDARD CHARACTER)**. UBLOX AG, MULTIPLE CLASS, (INT. CLS. 9, 38 AND 42), (U.S. CLS. 21, 23, 26, 36, 38, 100, 101 AND 104). SN 79-101,853. PUB. 1-10-2012. FILED 5-24-2011.
- 4,116,856. **6TH PLANET (STYLIZED)**. MONKUBE B.V.B.A., MULTIPLE CLASS, (INT. CLS. 9 AND 16), (U.S. CLS. 2, 5, 21, 22, 23, 26, 29, 36, 37, 38 AND 50). SN 79-102,061. PUB. 1-10-2012. FILED 6-9-2011.
- 4,116,862. **APPRASIVE (STANDARD CHARACTER)**. TYROLIT - SCHLEIFMITTELWERKE SWAROVSKI K.G., (U.S. CLS. 21, 23, 26, 36 AND 38). SN 79-102,526. PUB. 1-10-2012. FILED 8-9-2011.
- 4,116,863. **CONDOR (STANDARD CHARACTER)**. EUROPECA SPORT S.A.S., (U.S. CLS. 21, 23, 26, 36 AND 38). SN 79-103,099. PUB. 1-10-2012. FILED 7-1-2011.
- 4,116,866 (*See Class 7 for this trademark*).
- 4,116,869. **FLEXBOLT (STANDARD CHARACTER)**. NEXANS, (U.S. CLS. 21, 23, 26, 36 AND 38). SN 79-104,367. PUB. 1-10-2012. FILED 9-30-2011.
- 4,116,877. **BIZXAAS (STANDARD CHARACTER)**. KABUSHIKI KAISHA NTT DATA, DBA NTT DATA CORPORATION, MULTIPLE CLASS, (INT. CLS. 9, 37, 38 AND 42), (U.S. CLS. 21, 23, 26, 36, 38, 100, 101, 103, 104 AND 106). SN 85-007,128. PUB. 1-10-2012. FILED 4-6-2010.
- 4,116,880. **INTERNATIONAL ZONING CODE (STANDARD CHARACTER)**. INTERNATIONAL CODE COUNCIL, INC., MULTIPLE CLASS, (INT. CLS. 9, 41 AND 42), (U.S. CLS. 21, 23, 26, 36, 38, 100, 101 AND 107). SN 85-014,772. PUB. 1-10-2012. FILED 4-15-2010.
- 4,116,881. **INTERNATIONAL PLUMBING CODE (STANDARD CHARACTER)**. INTERNATIONAL CODE COUNCIL, INC., MULTIPLE CLASS, (INT. CLS. 9, 41 AND 42), (U.S. CLS. 21, 23, 26, 36, 38, 100, 101 AND 107). SN 85-014,800. PUB. 1-10-2012. FILED 4-15-2010.
- 4,116,884. **NANIUM (STANDARD CHARACTER)**. NANIUM, S.A., MULTIPLE CLASS, (INT. CLS. 9, 35, 37, 39, 40 AND 42), (U.S. CLS. 21, 23, 26, 36, 38, 100, 101, 102, 103, 105 AND 106). SN 85-031,860. PUB. 1-10-2012. FILED 5-6-2010.
- 4,116,885. **BODYTRONIC (STANDARD CHARACTER)**. BAUERFEIND AG, MULTIPLE CLASS, (INT. CLS. 9, 10, 25 AND 44), (U.S. CLS. 21, 22, 23, 26, 36, 38, 39, 44, 100 AND 101). SN 85-035,237. PUB. 1-10-2012. FILED 5-11-2010.
- 4,116,889. **SOLLEKTOR (STANDARD CHARACTER)**. GEORG-SIMON-OHM-HOCHSCHULE FÜR ANGEWANDTE WISSENSCHAFTEN - FACHHOCHSCHULE NÜRNBERG, MULTIPLE CLASS, (INT. CLS. 9, 11 AND 42), (U.S. CLS. 13, 21, 23, 26, 31, 34, 36, 38, 100 AND 101). SN 85-042,738. PUB. 1-10-2012. FILED 5-19-2010.
- 4,116,895. **R AND DESIGN**. U-NICA INTERNATIONAL AG, MULTIPLE CLASS, (INT. CLS. 9, 35 AND 45), (U.S. CLS. 21, 23, 26, 36, 38, 100, 101 AND 102). SN 85-066,737. PUB. 1-10-2012. FILED 6-18-2010.
- 4,116,897. **EZMOUNT (STANDARD CHARACTER)**. TENSOLITE, LLC, (U.S. CLS. 21, 23, 26, 36 AND 38). SN 85-067,336. PUB. 1-10-2012. FILED 6-21-2010.
- 4,116,898. **THE BONE BY GATOR AND DESIGN**. GATOR CASES, INC., (U.S. CLS. 21, 23, 26, 36 AND 38). SN 85-069,611. PUB. 1-10-2012. FILED 6-23-2010.
- 4,116,903. **DIGIMAX (STANDARD CHARACTER)**. ATX NETWORKS CORP., (U.S. CLS. 21, 23, 26, 36 AND 38). SN 85-073,825. PUB. 1-10-2012. FILED 6-29-2010.
- 4,116,904. **LC&D AND DESIGN**. LIGHTING CONCEPTS AND SOLUTIONS, INC., MULTIPLE CLASS, (INT. CLS. 9 AND 11), (U.S. CLS. 13, 21, 23, 26, 31, 34, 36 AND 38). SN 85-074,605. PUB. 1-10-2012. FILED 6-30-2010.
- 4,116,906. **MALIBU (STANDARD CHARACTER)**. J. BAXTER BRINKMANN INTERNATIONAL CORPORATION, (U.S. CLS. 21, 23, 26, 36 AND 38). SN 85-077,483. PUB. 1-10-2012. FILED 7-2-2010.
- 4,116,911 (*See Class 5 for this trademark*).
- 4,116,912 (*See Class 5 for this trademark*).
- 4,116,915. **MISCELLANEOUS DESIGN**. RED LAMBDA, INC., MULTIPLE CLASS, (INT. CLS. 9 AND 42), (U.S. CLS. 21, 23, 26, 36, 38, 100 AND 101). SN 85-091,775. PUB. 1-10-2012. FILED 7-23-2010.
- 4,116,916. **TOP GEAR (STANDARD CHARACTER)**. THE BRITISH BROADCASTING CORPORATION, MULTIPLE CLASS, (INT. CLS. 9, 28 AND 41), (U.S. CLS. 21, 22, 23, 26, 36, 38, 50, 100, 101 AND 107). SN 85-093,427. PUB. 1-10-2012. FILED 7-27-2010.
- 4,116,921. **TOUCHYBOOKS AND DESIGN**. GENERA INTERACTIVE, S.L., MULTIPLE CLASS, (INT. CLS. 9, 35 AND

- 41), (U.S. CLS. 21, 23, 26, 36, 38, 100, 101, 102 AND 107). SN 85-096,900. PUB. 1-10-2012. FILED 7-30-2010.
- 4,116,924. **SECONDWIND (STANDARD CHARACTER)**. ANJYE COMPANY LTD, (U.S. CLS. 21, 23, 26, 36 AND 38). SN 85-097,820. PUB. 1-10-2012. FILED 8-2-2010.
- 4,116,926. **X (STYLIZED)**. BOMBARDIER RECREATIONAL PRODUCTS INC., MULTIPLE CLASS, (INT. CLS. 9, 12, 18, 25 AND 28), (U.S. CLS. 1, 2, 3, 19, 21, 22, 23, 26, 31, 35, 36, 38, 39, 41, 44 AND 50). SN 85-099,439. PUB. 8-9-2011. FILED 8-3-2010.
- 4,116,927. **X (STYLIZED)**. BOMBARDIER RECREATIONAL PRODUCTS INC., MULTIPLE CLASS, (INT. CLS. 9, 12, 18, 25 AND 28), (U.S. CLS. 1, 2, 3, 19, 21, 22, 23, 26, 31, 35, 36, 38, 39, 41, 44 AND 50). SN 85-099,626. PUB. 8-9-2011. FILED 8-4-2010.
- 4,116,937. **KELVIN TOP SET AND DESIGN**. THE KELVIN CONSULTANTS LIMITED, MULTIPLE CLASS, (INT. CLS. 9, 16, 41 AND 45), (U.S. CLS. 2, 5, 21, 22, 23, 26, 29, 36, 37, 38, 50, 100, 101 AND 107). SN 85-118,568. PUB. 6-21-2011. FILED 8-30-2010.
- 4,116,952. **FASTSTEP KINETICS (STANDARD CHARACTER)**. NOMADICS, INC., (U.S. CLS. 21, 23, 26, 36 AND 38). SN 85-132,312. PUB. 1-10-2012. FILED 9-17-2010.
- 4,116,963. **SHAREWORKS PREMIER (STANDARD CHARACTER)**. SOLIUM CAPITAL INC., MULTIPLE CLASS, (INT. CLS. 9 AND 42), (U.S. CLS. 21, 23, 26, 36, 38, 100 AND 101). SN 85-143,536. PUB. 1-10-2012. FILED 10-1-2010.
- 4,116,969. **MANAGING TEAM RESPONSE (STANDARD CHARACTER)**. SHELDON INVESTMENT GROUP, INC., DBA SCAN AM COMPANY, (U.S. CLS. 21, 23, 26, 36 AND 38). SN 85-154,767. PUB. 1-10-2012. FILED 10-18-2010.
- 4,116,974. **CADENCE SCIENCE AND DESIGN**. CADENCE, INC., MULTIPLE CLASS, (INT. CLS. 9 AND 10), (U.S. CLS. 21, 23, 26, 36, 38, 39 AND 44). SN 85-161,194. PUB. 10-4-2011. FILED 10-26-2010.
- 4,116,984. **MILYLI (STANDARD CHARACTER)**. MILYLI INC., AKA MILYLI, (U.S. CLS. 21, 23, 26, 36 AND 38). SN 85-172,142. PUB. 1-10-2012. FILED 11-9-2010.
- 4,117,010 (*See Class 6 for this trademark*).
- 4,117,014. **BROADLEY JAMES (STANDARD CHARACTER)**. BROADLEY-JAMES CORPORATION, (U.S. CLS. 21, 23, 26, 36 AND 38). SN 85-197,766. PUB. 1-10-2012. FILED 12-14-2010.
- 4,117,022. **RNG INTERNATIONAL (STANDARD CHARACTER)**. RNG INTERNATIONAL EDUCATIONAL CONSULTANTS, LLC, MULTIPLE CLASS, (INT. CLS. 9, 16, 36 AND 41), (U.S. CLS. 2, 5, 21, 22, 23, 26, 29, 36, 37, 38, 50, 100, 101, 102 AND 107). SN 85-200,689. PUB. 1-10-2012. FILED 12-17-2010.
- 4,117,023. **REBECCA GRAPPO (STANDARD CHARACTER)**. RNG INTERNATIONAL EDUCATIONAL CONSULTANTS, LLC, MULTIPLE CLASS, (INT. CLS. 9, 16, 36 AND 41), (U.S. CLS. 2, 5, 21, 22, 23, 26, 29, 36, 37, 38, 50, 100, 101, 102 AND 107). SN 85-200,715. PUB. 1-10-2012. FILED 12-17-2010.
- 4,117,024. **EDUCATING GLOBAL NOMADS (STANDARD CHARACTER)**. RNG INTERNATIONAL EDUCATIONAL CONSULTANTS, LLC, MULTIPLE CLASS, (INT. CLS. 9, 16, 36 AND 41), (U.S. CLS. 2, 5, 21, 22, 23, 26, 29, 36, 37, 38, 50, 100, 101, 102 AND 107). SN 85-200,751. PUB. 1-10-2012. FILED 12-17-2010.
- 4,117,032. **MERCURY VINTAGE AUDIO TRANSFORMER BLUE PRINTING & RESTORATIONS FOUNDING MEMBER OF THE VINTAGE TONE PRESERVATION SOCIETY AND DESIGN**. SERGIO HAMERNIK, MULTIPLE CLASS, (INT. CLS. 9, 25 AND 37), (U.S. CLS. 21, 22, 23, 26, 36, 38, 39, 100, 103 AND 106). SN 85-206,069. PUB. 1-10-2012. FILED 12-27-2010.
- 4,117,044. **ZIA SYSTEMS (STANDARD CHARACTER)**. ZIA SYSTEMS LLC, (U.S. CLS. 21, 23, 26, 36 AND 38). SN 85-211,555. PUB. 1-10-2012. FILED 1-6-2011.
- 4,117,045. **WELLS-GARDNER (STANDARD CHARACTER)**. WELLS-GARDNER ELECTRONICS CORPORATION, (U.S. CLS. 21, 23, 26, 36 AND 38). SN 85-211,625. PUB. 1-10-2012. FILED 1-6-2011.
- 4,117,050. **TUBI (STANDARD CHARACTER)**. BEST MOVIL C.A., (U.S. CLS. 21, 23, 26, 36 AND 38). SN 85-215,723. PUB. 1-10-2012. FILED 1-12-2011.
- 4,117,053. **THIN-CAM (STANDARD CHARACTER)**. THIN-SITE, LLC, (U.S. CLS. 21, 23, 26, 36 AND 38). SN 85-216,886. PUB. 1-10-2012. FILED 1-13-2011.
- 4,117,058. **RED DIGITAL CINEMA PROFESSIONAL AND DESIGN**. RED.COM, INC., (U.S. CLS. 21, 23, 26, 36 AND 38). SN 85-218,455. PUB. 1-10-2012. FILED 1-14-2011.
- 4,117,087. **CAM-DUCT (STANDARD CHARACTER)**. TECHNICAL SALES INTERNATIONAL, LLC, (U.S. CLS. 21, 23, 26, 36 AND 38). SN 85-223,718. PUB. 1-10-2012. FILED 1-21-2011.
- 4,117,089. **THE SWEET REMAINS (STANDARD CHARACTER)**. CHARTRAND, BRIAN, AND PRICE, RICH, AND NAUGHTON, GREG, (U.S. CLS. 21, 23, 26, 36 AND 38). SN 85-223,827. PUB. 1-10-2012. FILED 1-22-2011.
- 4,117,090. **BETHEL MUSIC (STANDARD CHARACTER)**. BETHEL CHURCH OF REDDING, MULTIPLE CLASS, (INT. CLS. 9, 16, 25, 35, 41 AND 45), (U.S. CLS. 2, 5, 21, 22, 23, 26, 29, 36, 37, 38, 39, 50, 100, 101, 102 AND 107). SN 85-224,640. PUB. 1-10-2012. FILED 1-24-2011.
- 4,117,102. **BLUE MARLIN IBIZA AND DESIGN**. JELLE OOMES, MULTIPLE CLASS, (INT. CLS. 9 AND 41), (U.S. CLS. 21, 23, 26, 36, 38, 100, 101 AND 107). SN 85-226,362. PUB. 1-10-2012. FILED 1-26-2011.
- 4,117,104. **CTD-DIVER (STANDARD CHARACTER)**. SCHLUMBERGER WATER SERVICES (NETHERLANDS) B.V., (U.S. CLS. 21, 23, 26, 36 AND 38). SN 85-226,872. PUB. 1-10-2012. FILED 1-26-2011.
- 4,117,111. **J.T. AND DESIGN**. JYE TAI PRECISION INDUSTRIAL CO., LTD., (U.S. CLS. 21, 23, 26, 36 AND 38). SN 85-228,832. PUB. 1-10-2012. FILED 1-28-2011.
- 4,117,141. **AYIRA (STANDARD CHARACTER)**. WAHOUIÉ, JAMEELAH ZADDYS, MULTIPLE CLASS, (INT. CLS. 9, 16, 28 AND 41), (U.S. CLS. 2, 5, 21, 22, 23, 26, 29, 36, 37, 38, 50, 100, 101 AND 107). SN 85-232,921. PUB. 1-10-2012. FILED 2-3-2011.
- 4,117,143. **LINESMAKER (STANDARD CHARACTER)**. JAZETTE ENTERPRISES LIMITED, MULTIPLE CLASS, (INT. CLS. 9, 36 AND 41), (U.S. CLS. 21, 23, 26, 36, 38, 100, 101, 102 AND 107). SN 85-233,442. PUB. 1-10-2012. FILED 2-3-2011.
- 4,117,144. **FIRECEPTOR (STANDARD CHARACTER)**. VIRTUAL CONTEXT INC., (U.S. CLS. 21, 23, 26, 36 AND 38). SN 85-233,485. PUB. 1-10-2012. FILED 2-3-2011.
- 4,117,145. **KNOX (STANDARD CHARACTER)**. THE HOEFLER TYPE FOUNDRY, INC., DBA HOEFLER & FRERE-JONES, (U.S. CLS. 21, 23, 26, 36 AND 38). SN 85-233,624. PUB. 1-10-2012. FILED 2-3-2011.
- 4,117,148. **MATSON ALARM (STANDARD CHARACTER)**. MATSON ALARM COMPANY, INC., (U.S. CLS. 21, 23, 26, 36 AND 38). SN 85-233,752. PUB. 1-10-2012. FILED 2-3-2011.
- 4,117,166. **SURELABEL (STANDARD CHARACTER)**. MACHINE VISION CONSULTING, INC., MULTIPLE CLASS, (INT. CLS. 9 AND 42), (U.S. CLS. 21, 23, 26, 36, 38, 100 AND 101). SN 85-235,767. PUB. 1-10-2012. FILED 2-7-2011.
- 4,117,173. **YELLOW APE (STANDARD CHARACTER)**. HAGGERTY, JAMES P., (U.S. CLS. 21, 23, 26, 36 AND 38). SN 85-236,363. PUB. 1-10-2012. FILED 2-8-2011.
- 4,117,175. **GRAITEC ADVANCE AND DESIGN**. GRAITEC SA, MULTIPLE CLASS, (INT. CLS. 9 AND 42), (U.S. CLS. 21, 23, 26, 36, 38, 100 AND 101). SN 85-236,928. PUB. 1-10-2012. FILED 2-8-2011.
- 4,117,189. **EXPRESSFABRIC (STANDARD CHARACTER)**. PLX TECHNOLOGY, INC., (U.S. CLS. 21, 23, 26, 36 AND 38). SN 85-239,316. PUB. 1-10-2012. FILED 2-10-2011.
- 4,117,214. **PLATINUM SOUND (STANDARD CHARACTER)**. JERRY DUPLESSIS, (U.S. CLS. 21, 23, 26, 36 AND 38). SN 85-242,124. PUB. 1-10-2012. FILED 2-14-2011.
- 4,117,215. **FYLO AND DESIGN**. HOORAY, LLC, (U.S. CLS. 21, 23, 26, 36 AND 38). SN 85-242,526. PUB. 1-10-2012. FILED 2-15-2011.
- 4,117,219. **GEMINIVIEW (STANDARD CHARACTER)**. BAKER HUGHES INCORPORATED, (U.S. CLS. 21, 23, 26, 36 AND 38). SN 85-243,482. PUB. 1-10-2012. FILED 2-16-2011.
- 4,117,225. **THE CONOVER COMPANY (STANDARD CHARACTER)**. OAKWOOD SOLUTIONS, LLC, DBA THE CONOVER COMPANY, MULTIPLE CLASS, (INT. CLS. 9 AND 42), (U.S. CLS. 21, 23, 26, 36, 38, 100 AND 101). SN 85-245,405. PUB. 1-10-2012. FILED 2-17-2011.
- 4,117,233. **ISENSE (STANDARD CHARACTER)**. AD PEPPER MEDIA INTERNATIONAL N.V., MULTIPLE CLASS, (INT.

- CLS. 9, 35, 38 AND 42), (U.S. CLS. 21, 23, 26, 36, 38, 100, 101, 102 AND 104). SN 85-246,418. PUB. 1-10-2012. FILED 2-18-2011.
- 4,117,236. **APPLICATION CRAFT (STANDARD CHARACTER)**. APPLICATION CRAFT UK LTD, (U.S. CLS. 21, 23, 26, 36 AND 38). SN 85-247,187. PUB. 1-10-2012. FILED 2-21-2011.
- 4,117,252. **GEOXRAY (STANDARD CHARACTER)**. GEOSSEMBLE TECHNOLOGIES INC., MULTIPLE CLASS, (INT. CLS. 9 AND 42), (U.S. CLS. 21, 23, 26, 36, 38, 100 AND 101). SN 85-249,325. PUB. 1-10-2012. FILED 2-23-2011.
- 4,117,253. **COMTREND AND DESIGN**. COMTREND CORPORATION, (U.S. CLS. 21, 23, 26, 36 AND 38). SN 85-249,396. PUB. 1-10-2012. FILED 2-23-2011.
- 4,117,257. **HEAT TRANSFER MANAGER (STANDARD CHARACTER)**. BABCOCK & WILCOX POWER GENERATION GROUP, INC., (U.S. CLS. 21, 23, 26, 36 AND 38). SN 85-250,679. PUB. 1-10-2012. FILED 2-24-2011.
- 4,117,259. **HEALTHCARE ALERT AND DESIGN**. DR. JIMENEZ ALFONSO, MULTIPLE CLASS, (INT. CLS. 9 AND 38), (U.S. CLS. 21, 23, 26, 36, 38, 100, 101 AND 104). SN 85-251,444. PUB. 1-10-2012. FILED 2-25-2011.
- 4,117,262. **CARNIVAL COMICS (STANDARD CHARACTER)**. BARNES, JASON P., AKA JAZAN WILD, MULTIPLE CLASS, (INT. CLS. 9 AND 41), (U.S. CLS. 21, 23, 26, 36, 38, 100, 101 AND 107). SN 85-252,296. PUB. 1-10-2012. FILED 2-25-2011.
- 4,117,268. **PORTFOLIO OPTIMIZER (STANDARD CHARACTER)**. METIER, LTD, (U.S. CLS. 21, 23, 26, 36 AND 38). SN 85-253,903. PUB. 1-10-2012. FILED 2-28-2011.
- 4,117,269. **THE COLLECTIVE C (STYLIZED)**. THE COLLECTIVE MANAGEMENT GROUP, MULTIPLE CLASS, (INT. CLS. 9 AND 35), (U.S. CLS. 21, 23, 26, 36, 38, 100, 101 AND 102). SN 85-253,906. PUB. 1-10-2012. FILED 2-28-2011.
- 4,117,274. **PERISCOPE (STANDARD CHARACTER)**. ERIC FISHERMAN, INC., (U.S. CLS. 21, 23, 26, 36 AND 38). SN 85-255,303. PUB. 1-10-2012. FILED 3-2-2011.
- 4,117,275. **COVER+LIGHT (STANDARD CHARACTER)**. ERIC FISHERMAN, INC., (U.S. CLS. 21, 23, 26, 36 AND 38). SN 85-255,305. PUB. 1-10-2012. FILED 3-2-2011.
- 4,117,303. **EDIBLE STUDIO AND DESIGN**. EDIBLE SUPPLY, (U.S. CLS. 21, 23, 26, 36 AND 38). SN 85-260,434. PUB. 1-10-2012. FILED 3-8-2011.
- 4,117,330. **DYNAMARK (STANDARD CHARACTER)**. FIRST ACTION SECURITY TEAM, INC., (U.S. CLS. 21, 23, 26, 36 AND 38). SN 85-267,333. PUB. 1-10-2012. FILED 3-15-2011.
- 4,117,352. **SUPREME COURT DEBATES (STANDARD CHARACTER)**. THE CONGRESSIONAL DIGEST CORPORATION, (U.S. CLS. 21, 23, 26, 36 AND 38). SN 85-272,243. PUB. 1-10-2012. FILED 3-21-2011.
- 4,117,355. **S-PAR (STANDARD CHARACTER)**. UNISYS CORPORATION, (U.S. CLS. 21, 23, 26, 36 AND 38). SN 85-273,052. PUB. 1-10-2012. FILED 3-22-2011.
- 4,117,357. **CAREVIZ (STANDARD CHARACTER)**. RUNZHEIMER INTERNATIONAL LTD., MULTIPLE CLASS, (INT. CLS. 9 AND 42), (U.S. CLS. 21, 23, 26, 36, 38, 100 AND 101). SN 85-273,379. PUB. 1-10-2012. FILED 3-22-2011.
- 4,117,363. **NO MAN'S WORLD (STANDARD CHARACTER)**. CHRISTOPHER KINGSLEY, AND JASON KINGSLEY, MULTIPLE CLASS, (INT. CLS. 9, 16, 28 AND 41), (U.S. CLS. 2, 5, 21, 22, 23, 26, 29, 36, 37, 38, 50, 100, 101 AND 107). SN 85-274,647. PUB. 1-10-2012. FILED 3-23-2011.
- 4,117,378. **HIPPO AND DESIGN**. ECO GROUP ASIA LTD, MULTIPLE CLASS, (INT. CLS. 9 AND 11), (U.S. CLS. 13, 21, 23, 26, 31, 34, 36 AND 38). SN 85-279,237. PUB. 1-10-2012. FILED 3-28-2011.
- 4,117,380. **RICH HIL (STANDARD CHARACTER)**. RICHARD HILFIGER, MULTIPLE CLASS, (INT. CLS. 9 AND 41), (U.S. CLS. 21, 23, 26, 36, 38, 100, 101 AND 107). SN 85-279,844. PUB. 1-10-2012. FILED 3-29-2011.
- 4,117,385. **SMITHS (STANDARD CHARACTER)**. CAERBONT AUTOMOTIVE INSTRUMENTS LIMITED, (U.S. CLS. 21, 23, 26, 36 AND 38). SN 85-280,115. PUB. 1-10-2012. FILED 3-29-2011.
- 4,117,388. **BONDMASTER (STANDARD CHARACTER)**. OLYMPUS CORPORATION, (U.S. CLS. 21, 23, 26, 36 AND 38). SN 85-280,948. PUB. 1-10-2012. FILED 3-30-2011.
- 4,117,394. **DEBBIE MACOMBER (STANDARD CHARACTER)**. DEBBIE MACOMBER, INC., (U.S. CLS. 21, 23, 26, 36 AND 38). SN 85-281,485. PUB. 1-10-2012. FILED 3-30-2011.
- 4,117,398. **SPANISH 21 (STANDARD CHARACTER)**. MASQUE PUBLISHING, INC., (U.S. CLS. 21, 23, 26, 36 AND 38). SN 85-282,008. PUB. 1-10-2012. FILED 3-31-2011.
- 4,117,404. **STARLIGHT CLASSICS AND DESIGN**. KATARZYNA KARKOWSKA, DBA STARLIGHT CLASSICS, (U.S. CLS. 21, 23, 26, 36 AND 38). SN 85-283,219. PUB. 1-10-2012. FILED 3-31-2011.
- 4,117,409. **FLEX CAM (STANDARD CHARACTER)**. SMOKIN' RACK PRODUCTS, LLC, (U.S. CLS. 21, 23, 26, 36 AND 38). SN 85-284,028. PUB. 1-10-2012. FILED 4-1-2011.
- 4,117,421. **FLOW 40 (STANDARD CHARACTER)**. CHENOK, GRANT P, AND DRAGO, NICHOLAS D, MULTIPLE CLASS, (INT. CLS. 9 AND 41), (U.S. CLS. 21, 23, 26, 36, 38, 100, 101 AND 107). SN 85-287,137. PUB. 1-10-2012. FILED 4-5-2011.
- 4,117,430. **SOICHA (STANDARD CHARACTER)**. FLIGHT SYSTEM CONSULTING, INC., MULTIPLE CLASS, (INT. CLS. 9 AND 42), (U.S. CLS. 21, 23, 26, 36, 38, 100 AND 101). SN 85-289,282. PUB. 1-10-2012. FILED 4-7-2011.
- 4,117,444. **VOXIFY (STANDARD CHARACTER)**. VOXIFY, INC., MULTIPLE CLASS, (INT. CLS. 9 AND 42), (U.S. CLS. 21, 23, 26, 36, 38, 100 AND 101). SN 85-292,032. PUB. 1-10-2012. FILED 4-11-2011.
- 4,117,447. **SAFETYGRID ! AND DESIGN**. ALL POINTS MEDIA WORKS, LLC, (U.S. CLS. 21, 23, 26, 36 AND 38). SN 85-292,704. PUB. 1-10-2012. FILED 4-12-2011.
- 4,117,449. **CRYSTAL ICING (STANDARD CHARACTER)**. CRYSTAL ICING, LLC, (U.S. CLS. 21, 23, 26, 36 AND 38). SN 85-292,947. PUB. 1-10-2012. FILED 4-12-2011.
- 4,117,459. **COMPASS POINT STUDIOS AND DESIGN**. MANNING, TERRY, AND BLACKWELL, CHRISTOPHER, (U.S. CLS. 21, 23, 26, 36 AND 38). SN 85-294,444. PUB. 1-10-2012. FILED 4-13-2011.
- 4,117,467. **SLY BOOBY (STANDARD CHARACTER)**. MARTIN, TIMOTHY, MULTIPLE CLASS, (INT. CLS. 9, 25 AND 41), (U.S. CLS. 21, 22, 23, 26, 36, 38, 39, 100, 101 AND 107). SN 85-295,267. PUB. 1-10-2012. FILED 4-14-2011.
- 4,117,481. **AERIA AND DESIGN**. AERIA SOUND ENVIRONMENTS INC., (U.S. CLS. 21, 23, 26, 36 AND 38). SN 85-298,119. PUB. 1-10-2012. FILED 4-18-2011.
- 4,117,488. **CC CASE CONTROLS (STYLIZED)**. CASE ENGINEERING, LLC, DBA CASE CONTROLS, (U.S. CLS. 21, 23, 26, 36 AND 38). SN 85-300,161. PUB. 1-10-2012. FILED 4-20-2011.
- 4,117,491. **SEOQUAKE (STANDARD CHARACTER)**. SHCHEGOLEV, OLEG, DBA SEOQUAKE TEAM, MULTIPLE CLASS, (INT. CLS. 9 AND 35), (U.S. CLS. 21, 23, 26, 36, 38, 100, 101 AND 102). SN 85-300,686. PUB. 1-10-2012. FILED 4-21-2011.
- 4,117,503. **H AND DESIGN**. L-COM, INC., (U.S. CLS. 21, 23, 26, 36 AND 38). SN 85-302,360. PUB. 1-10-2012. FILED 4-22-2011.
- 4,117,511. **M MODA MORE SCIENCE. LESS PAPER. AND DESIGN**. LONZA WALKERSVILLE, INC., (U.S. CLS. 21, 23, 26, 36 AND 38). SN 85-303,598. PUB. 1-10-2012. FILED 4-25-2011.
- 4,117,519. **INTELLEQT (STANDARD CHARACTER)**. MULTILOCK TECHNOLOGIES LTD., (U.S. CLS. 21, 23, 26, 36 AND 38). SN 85-305,309. PUB. 1-10-2012. FILED 4-26-2011.
- 4,117,530. **CRYOSTAR (STANDARD CHARACTER)**. MICROM INTERNATIONAL GMBH, (U.S. CLS. 21, 23, 26, 36 AND 38). SN 85-308,579. PUB. 1-10-2012. FILED 4-29-2011.
- 4,117,546. **ADNUO AND DESIGN**. VISIO SERVICES, LTD., (U.S. CLS. 21, 23, 26, 36 AND 38). SN 85-313,053. PUB. 1-10-2012. FILED 5-5-2011.
- 4,117,548. **MIDI FIGHTER (STANDARD CHARACTER)**. GOLDEN SOL MUSIC LLC, (U.S. CLS. 21, 23, 26, 36 AND 38). SN 85-313,620. PUB. 1-10-2012. FILED 5-5-2011.
- 4,117,549. **MISCELLANEOUS DESIGN**. SHANGHAI SILIN SPECIAL EQUIPMENT CO., LTD., (U.S. CLS. 21, 23, 26, 36 AND 38). SN 85-313,624. PUB. 1-10-2012. FILED 5-5-2011.
- 4,117,551. **VOXOFON (STANDARD CHARACTER)**. VOXOFON LLC, MULTIPLE CLASS, (INT. CLS. 9 AND 38), (U.S. CLS. 21, 23, 26, 36, 38, 100, 101 AND 104). SN 85-314,022. PUB. 1-10-2012. FILED 5-6-2011.
- 4,117,565. **MISCELLANEOUS DESIGN**. QUALITY SOFTWARE SERVICES, INC., (U.S. CLS. 21, 23, 26, 36 AND 38).

- SN 85-317,766. PUB. 10-4-2011. FILED 5-11-2011.
- 4,117,582. **TACVIEW (STANDARD CHARACTER)**. GILMER, GEORGE T., (U.S. CLS. 21, 23, 26, 36 AND 38). SN 85-321,922. PUB. 1-10-2012. FILED 5-16-2011.
- 4,117,592. **TEKPOWER (STANDARD CHARACTER)**. ZHAO, WALTER GQ. (U.S. CLS. 21, 23, 26, 36 AND 38). SN 85-323,406. PUB. 1-10-2012. FILED 5-17-2011.
- 4,117,595. **PROCESSING.COM (STANDARD CHARACTER)**. CHAMELEON SOFTWARE, INC., MULTIPLE CLASS, (INT. CLS. 9 AND 42), (U.S. CLS. 21, 23, 26, 36, 38, 100 AND 101). SN 85-323,799. PUB. 1-10-2012. FILED 5-18-2011.
- 4,117,622. **BCDVIDEO (STANDARD CHARACTER)**. BURGESS COMPUTER DECISIONS, INC., MULTIPLE CLASS, (INT. CLS. 9 AND 42), (U.S. CLS. 21, 23, 26, 36, 38, 100 AND 101). SN 85-327,697. PUB. 1-10-2012. FILED 5-23-2011.
- 4,117,628. **OE AND DESIGN**. CASA GRANDE INTERACTIVE COMMUNICATIONS, INC., (U.S. CLS. 21, 23, 26, 36 AND 38). SN 85-329,072. PUB. 1-10-2012. FILED 5-24-2011.
- 4,117,634. **YOUR PASSPORT TO PROFITABILITY (STANDARD CHARACTER)**. INTERNATIONAL BANCARD CORPORATION, MULTIPLE CLASS, (INT. CLS. 9 AND 36), (U.S. CLS. 21, 23, 26, 36, 38, 100, 101 AND 102). SN 85-330,804. PUB. 1-10-2012. FILED 5-26-2011.
- 4,117,635. **NOISEPRO (STANDARD CHARACTER)**. JINAN PROPLUS ELECTRONICS CO. LTD., DBA KHAI-LONG PROPLUS, (U.S. CLS. 21, 23, 26, 36 AND 38). SN 85-331,061. PUB. 1-10-2012. FILED 5-26-2011.
- 4,117,658. **MICRI*M (STYLIZED)**. MICRIUM, INC., MULTIPLE CLASS, (INT. CLS. 9, 16, 41 AND 42), (U.S. CLS. 2, 5, 21, 22, 23, 26, 29, 36, 37, 38, 50, 100, 101 AND 107). SN 85-335,174. PUB. 1-10-2012. FILED 6-1-2011.
- 4,117,672. **ROYAL RANGERS AND DESIGN**. THE GENERAL COUNCIL OF THE ASSEMBLIES OF GOD, MULTIPLE CLASS, (INT. CLS. 9, 16, 25, 26 AND 41), (U.S. CLS. 2, 5, 21, 22, 23, 26, 29, 36, 37, 38, 39, 40, 42, 50, 100, 101 AND 107). SN 85-337,741. PUB. 1-10-2012. FILED 6-3-2011.
- 4,117,692. **HDMI HIGH SPEED WITH ETHERNET AND DESIGN**. HDMI LICENSING, L.L.C., (U.S. CLS. 21, 23, 26, 36 AND 38). SN 85-342,754. PUB. 1-10-2012. FILED 6-9-2011.
- 4,117,705. **TURNINGPOINT AND DESIGN**. RED WING SOFTWARE, INC., (U.S. CLS. 21, 23, 26, 36 AND 38). SN 85-344,593. PUB. 1-10-2012. FILED 6-13-2011.
- 4,117,708. **KELLEY BLUE BOOK (STANDARD CHARACTER)**. KELLEY BLUE BOOK CO., INC., (U.S. CLS. 21, 23, 26, 36 AND 38). SN 85-345,476. PUB. 1-10-2012. FILED 6-14-2011.
- 4,117,709. **KELLEY BLUE BOOK OFFICIAL GUIDE AND DESIGN**. KELLEY BLUE BOOK CO., INC., (U.S. CLS. 21, 23, 26, 36 AND 38). SN 85-345,480. PUB. 1-10-2012. FILED 6-14-2011.
- 4,117,710. **JOB MO (STANDARD CHARACTER)**. KIEFER CONSULTING, INC., (U.S. CLS. 21, 23, 26, 36 AND 38). SN 85-345,488. PUB. 1-10-2012. FILED 6-14-2011.
- 4,117,718. **MERLIN ADD A LITTLE MAGIC TO YOUR LIFE AND DESIGN**. BACHANI, SUHAIL, (U.S. CLS. 21, 23, 26, 36 AND 38). SN 85-347,288. PUB. 1-10-2012. FILED 6-15-2011.
- 4,117,729. **JUSTSYNC (STANDARD CHARACTER)**. JSMG WORLDWIDE, INC., (U.S. CLS. 21, 23, 26, 36 AND 38). SN 85-349,180. PUB. 1-10-2012. FILED 6-17-2011.
- 4,117,738. **TOUCH BIOS HYBRID EFI TECHNOLOGY AND DESIGN**. GIGA-BYTE TECHNOLOGY CO., LTD., (U.S. CLS. 21, 23, 26, 36 AND 38). SN 85-350,199. PUB. 1-10-2012. FILED 6-20-2011.
- 4,117,741. **LITEYE AND DESIGN**. LITEYE SYSTEMS INC., (U.S. CLS. 21, 23, 26, 36 AND 38). SN 85-351,015. PUB. 1-10-2012. FILED 6-20-2011.
- 4,117,747. **J JEFIT AND DESIGN**. JEFIT INC., (U.S. CLS. 21, 23, 26, 36 AND 38). SN 85-351,566. PUB. 1-10-2012. FILED 6-21-2011.
- 4,117,754. **EG (STYLIZED)**. GOLDEN EMPEROR INTERNATIONAL LTD., (U.S. CLS. 21, 23, 26, 36 AND 38). SN 85-352,051. PUB. 1-10-2012. FILED 6-21-2011.
- 4,117,755. **INECK (STANDARD CHARACTER)**. WORLEY, JOHN W., (U.S. CLS. 21, 23, 26, 36 AND 38). SN 85-352,057. PUB. 1-10-2012. FILED 6-21-2011.
- 4,117,769. **RENOVOFYI (STANDARD CHARACTER)**. RENOVVO CORPORATION, (U.S. CLS. 21, 23, 26, 36 AND 38). SN 85-353,857. PUB. 1-10-2012. FILED 6-23-2011.
- 4,117,776. **WIPEOUT AND DESIGN**. YP IP LIMITED, (U.S. CLS. 21, 23, 26, 36 AND 38). SN 85-355,064. PUB. 1-10-2012. FILED 6-24-2011.
- 4,117,787. **GREEK123 (STANDARD CHARACTER)**. PAPALIOZOS PUBLICATIONS INC., MULTIPLE CLASS, (INT. CLS. 9, 16 AND 42), (U.S. CLS. 2, 5, 21, 22, 23, 26, 29, 36, 37, 38, 50, 100 AND 101). SN 85-356,433. PUB. 1-10-2012. FILED 6-26-2011.
- 4,117,823. **SAMPLESAFE (STANDARD CHARACTER)**. S. D. MYERS, INC., (U.S. CLS. 21, 23, 26, 36 AND 38). SN 85-360,559. PUB. 1-10-2012. FILED 6-30-2011.
- 4,117,834. **SNOW PEAK AND DESIGN**. SNOW PEAK INC., MULTIPLE CLASS, (INT. CLS. 9 AND 18), (U.S. CLS. 1, 2, 3, 21, 22, 23, 26, 36, 38 AND 41). SN 85-362,249. PUB. 1-10-2012. FILED 7-1-2011.
- 4,117,844. **GAME PUB AND DESIGN**. BLAEVOET, EDITH, (U.S. CLS. 21, 23, 26, 36 AND 38). SN 85-364,044. PUB. 1-10-2012. FILED 7-6-2011.
- 4,117,852. **CONGRESS IN YOUR POCKET (STANDARD CHARACTER)**. COHEN RESEARCH GROUP, INC., DBA COHEN RESEARCH GROUP, (U.S. CLS. 21, 23, 26, 36 AND 38). SN 85-364,484. PUB. 1-10-2012. FILED 7-6-2011.
- 4,117,857. **MOTHERMUSCLE (STANDARD CHARACTER)**. MOTHERMUSCLE, LLC, MULTIPLE CLASS, (INT. CLS. 9 AND 28), (U.S. CLS. 21, 22, 23, 26, 36, 38 AND 50). SN 85-364,926. PUB. 1-10-2012. FILED 7-7-2011.
- 4,117,865. **ACUITY AND DESIGN**. SCHMITT MEASUREMENT SYSTEMS, INC., (U.S. CLS. 21, 23, 26, 36 AND 38). SN 85-365,308. PUB. 1-10-2012. FILED 7-7-2011.
- 4,117,876. **SMS AND DESIGN**. SCHMITT MEASUREMENT SYSTEMS, INC., (U.S. CLS. 21, 23, 26, 36 AND 38). SN 85-365,939. PUB. 1-10-2012. FILED 7-7-2011.
- 4,117,882 (*See Class 6 for this trademark*).
- 4,117,952. **CAWA (STANDARD CHARACTER)**. CAWA INDUSTRIAL CO., LTD., (U.S. CLS. 21, 23, 26, 36 AND 38). SN 85-369,756. PUB. 1-10-2012. FILED 7-12-2011.
- 4,117,958. **RARE ROOTS RECORDS (STANDARD CHARACTER)**. PEARLMAN, GREGORY D., MULTIPLE CLASS, (INT. CLS. 9 AND 25), (U.S. CLS. 21, 22, 23, 26, 36, 38 AND 39). SN 85-370,292. PUB. 1-10-2012. FILED 7-13-2011.
- 4,118,129. **C.A.T (STANDARD CHARACTER)**. RADIODETECTION LIMITED, (U.S. CLS. 21, 23, 26, 36 AND 38). SN 85-375,047. PUB. 1-10-2012. FILED 7-19-2011.
- 4,118,132. **VALEO AND DESIGN**. HAULSEE, JUANITA, MULTIPLE CLASS, (INT. CLS. 9, 16 AND 41), (U.S. CLS. 2, 5, 21, 22, 23, 26, 29, 36, 37, 38, 50, 100, 101 AND 107). SN 85-375,077. PUB. 1-10-2012. FILED 7-19-2011.
- 4,118,133. **THE LITTLE BLUE BOOK (STANDARD CHARACTER)**. HCPLEXUS, INC., MULTIPLE CLASS, (INT. CLS. 9, 16 AND 35), (U.S. CLS. 2, 5, 21, 22, 23, 26, 29, 36, 37, 38, 50, 100, 101 AND 102). SN 85-375,156. PUB. 1-10-2012. FILED 7-19-2011.
- 4,118,134. **THE LITTLE BLUE BOOK (STYLIZED)**. HCPLEXUS, INC., MULTIPLE CLASS, (INT. CLS. 9, 16 AND 35), (U.S. CLS. 2, 5, 21, 22, 23, 26, 29, 36, 37, 38, 50, 100, 101 AND 102). SN 85-375,160. PUB. 1-10-2012. FILED 7-19-2011.
- 4,118,168. **LISSO ENTERPRISE (STANDARD CHARACTER)**. LOGLOGIC, INC., (U.S. CLS. 21, 23, 26, 36 AND 38). SN 85-375,578. PUB. 1-10-2012. FILED 7-19-2011.
- 4,118,198. **PIG RUSH (STANDARD CHARACTER)**. REIGN DIGITAL CREATIVES LIMITED, (U.S. CLS. 21, 23, 26, 36 AND 38). SN 85-376,768. PUB. 1-10-2012. FILED 7-20-2011.
- 4,118,236. **TAPJOY (STANDARD CHARACTER)**. TAPJOY, INC., MULTIPLE CLASS, (INT. CLS. 9, 35 AND 42), (U.S. CLS. 21, 23, 26, 36, 38, 100, 101 AND 102). SN 85-377,880. PUB. 1-10-2012. FILED 7-21-2011.
- 4,118,251. **POWERED BY PERCEPTRON AND DESIGN**. PERCEPTRON, INC., (U.S. CLS. 21, 23, 26, 36 AND 38). SN 85-378,675. PUB. 1-10-2012. FILED 7-22-2011.
- 4,118,252. **IMAGING POWERED BY PERCEPTRON AND DESIGN**. PERCEPTRON, INC., (U.S. CLS. 21, 23, 26, 36 AND 38). SN 85-378,686. PUB. 1-10-2012. FILED 7-22-2011.
- 4,118,262. **ENERGY PERSPECTIVES (STANDARD CHARACTER)**. SCHLUMBERGER TECHNOLOGY CORPORATION, (U.S. CLS. 21, 23, 26, 36 AND 38). SN 85-379,552. PUB. 1-10-2012. FILED 7-25-2011.
- 4,118,290. **RVING FUSESITCH (STANDARD CHARACTER)**. SHERWOOD REALTY GROUP INC., DBA RV PARTS

- PLUS, (U.S. CLS. 21, 23, 26, 36 AND 38). SN 85-380,851. PUB. 1-10-2012. FILED 7-26-2011.
- 4,118,294 (*See Class 3 for this trademark*).
- 4,118,325. **BOSSTRAP (STANDARD CHARACTER)**. BOSSTRAP LLC, (U.S. CLS. 21, 23, 26, 36 AND 38). SN 85-387,944. PUB. 1-10-2012. FILED 8-3-2011.
- 4,118,352. **DOTCOVER (STANDARD CHARACTER)**. JETBRAINS S.R.O., (U.S. CLS. 21, 23, 26, 36 AND 38). SN 85-389,710. PUB. 1-10-2012. FILED 8-4-2011.
- 4,118,353. **DOTTRACE (STANDARD CHARACTER)**. JETBRAINS S.R.O., (U.S. CLS. 21, 23, 26, 36 AND 38). SN 85-389,879. PUB. 1-10-2012. FILED 8-4-2011.
- 4,118,355. **MISCELLANEOUS DESIGN**. PROJETCLUB, MULTIPLE CLASS, (INT. CLS. 9, 18, 25 AND 28), (U.S. CLS. 1, 2, 3, 21, 22, 23, 26, 36, 38, 39, 41 AND 50). SN 85-389,980. PUB. 1-10-2012. FILED 8-4-2011.
- 4,118,360. **POLATIS (STANDARD CHARACTER)**. POLATIS, INC., (U.S. CLS. 21, 23, 26, 36 AND 38). SN 85-390,084. PUB. 1-10-2012. FILED 8-4-2011.
- 4,118,361. **POLATIS AND DESIGN**. POLATIS, INC., (U.S. CLS. 21, 23, 26, 36 AND 38). SN 85-390,094. PUB. 1-10-2012. FILED 8-4-2011.
- 4,118,373. **PRIVATE EYE (STANDARD CHARACTER)**. MNE-MONICS, INC., (U.S. CLS. 21, 23, 26, 36 AND 38). SN 85-390,833. PUB. 1-10-2012. FILED 8-5-2011.
- 4,118,380. **IPING (STANDARD CHARACTER)**. KARSTEN MANUFACTURING CORPORATION, (U.S. CLS. 21, 23, 26, 36 AND 38). SN 85-391,200. PUB. 1-10-2012. FILED 8-5-2011.
- 4,118,417. **STUPID ZOMBIES (STANDARD CHARACTER)**. GAMERESORT LLC, (U.S. CLS. 21, 23, 26, 36 AND 38). SN 85-392,640. PUB. 1-10-2012. FILED 8-8-2011.
- 4,118,426. **TRUECONF (STANDARD CHARACTER)**. TRUECONF PTY LTD, (U.S. CLS. 21, 23, 26, 36 AND 38). SN 85-392,808. PUB. 1-10-2012. FILED 8-9-2011.
- 4,118,435. **ENERPATH (STANDARD CHARACTER)**. ENER-NET, INC. DBA ENERPATH, (U.S. CLS. 21, 23, 26, 36 AND 38). SN 85-393,049. PUB. 1-10-2012. FILED 8-9-2011.
- 4,118,439. **TCC (STANDARD CHARACTER)**. CINEDIGM DIGITAL CINEMA CORP., (U.S. CLS. 21, 23, 26, 36 AND 38). SN 85-393,086. PUB. 1-10-2012. FILED 8-9-2011.
- 4,118,440. **INNOVATION CENTRAL (STANDARD CHARACTER)**. IMAGINATIK PLC, (U.S. CLS. 21, 23, 26, 36 AND 38). SN 85-393,088. PUB. 1-10-2012. FILED 8-9-2011.
- 4,118,445. **BLAZEMARK (STANDARD CHARACTER)**. FIRE PLANNING ASSOCIATES, INC., (U.S. CLS. 21, 23, 26, 36 AND 38). SN 85-393,192. PUB. 1-10-2012. FILED 8-9-2011.
- 4,118,449. **SUPER HOT HOT HOT CHILI PEPPERS (STANDARD CHARACTER)**. GATEWAY GAMING LLC, (U.S. CLS. 21, 23, 26, 36 AND 38). SN 85-393,232. PUB. 1-10-2012. FILED 8-9-2011.
- 4,118,464. **MUXGUARD (STANDARD CHARACTER)**. AFL TELECOMMUNICATIONS, LLC, (U.S. CLS. 21, 23, 26, 36 AND 38). SN 85-393,390. PUB. 1-10-2012. FILED 8-9-2011.
- 4,118,476. **VELLAMO (STANDARD CHARACTER)**. QUALCOMM INNOVATION CENTER, INC., (U.S. CLS. 21, 23, 26, 36 AND 38). SN 85-393,610. PUB. 1-10-2012. FILED 8-9-2011.
- 4,118,487. **DROPSYNC (STANDARD CHARACTER)**. COOKE, IRA R., (U.S. CLS. 21, 23, 26, 36 AND 38). SN 85-393,945. PUB. 1-10-2012. FILED 8-10-2011.
- 4,118,489. **QUANTLAB (STANDARD CHARACTER)**. ALGORITHMICA RESEARCH AB, (U.S. CLS. 21, 23, 26, 36 AND 38). SN 85-393,972. PUB. 1-10-2012. FILED 8-10-2011.
- 4,118,503. **WE PROTECT YOUR PRIVATE PARTS (STANDARD CHARACTER)**. JERICHO SYSTEMS CORPORATION, (U.S. CLS. 21, 23, 26, 36 AND 38). SN 85-394,259. PUB. 1-10-2012. FILED 8-10-2011.
- 4,118,518. **KEYHOLE (STANDARD CHARACTER)**. BACK-COUNTRY SOLUTIONS, LLC, (U.S. CLS. 21, 23, 26, 36 AND 38). SN 85-394,622. PUB. 1-10-2012. FILED 8-10-2011.
- 4,118,520. **ABBY MONKEY (STANDARD CHARACTER)**. 22LEARN, LLC, (U.S. CLS. 21, 23, 26, 36 AND 38). SN 85-394,629. PUB. 1-10-2012. FILED 8-10-2011.
- 4,118,574. **X-MEN (STANDARD CHARACTER)**. MARVEL CHARACTERS, INC., (U.S. CLS. 21, 23, 26, 36 AND 38). SN 85-395,748. PUB. 1-10-2012. FILED 8-11-2011.
- 4,118,581. **MISCELLANEOUS DESIGN**. FAIRVIEW IMPORT CORPORATION, (U.S. CLS. 21, 23, 26, 36 AND 38). SN 85-395,812. PUB. 1-10-2012. FILED 8-11-2011.
- 4,118,584. **ARRESTED DEVELOPMENT (STANDARD CHARACTER)**. VAGABOND "SPEECH" PRODUCTIONS, INC., (U.S. CLS. 21, 23, 26, 36 AND 38). SN 85-395,854. PUB. 1-10-2012. FILED 8-11-2011.
- 4,118,594. **[TFLN]; (STANDARD CHARACTER)**. TEXTS FROM LAST NIGHT, INC., (U.S. CLS. 21, 23, 26, 36 AND 38). SN 85-396,022. PUB. 1-10-2012. FILED 8-11-2011.
- 4,118,617. **PROFASHION (STANDARD CHARACTER)**. PROFASHION, INC., (U.S. CLS. 21, 23, 26, 36 AND 38). SN 85-396,639. PUB. 1-10-2012. FILED 8-12-2011.
- 4,118,619. **RADIATION ROMEO AND DESIGN**. BLADE, ADRIAN, (U.S. CLS. 21, 23, 26, 36 AND 38). SN 85-396,709. PUB. 1-10-2012. FILED 8-12-2011.
- 4,118,620. **INFINICAM (STANDARD CHARACTER)**. NEVER-CENTER, (U.S. CLS. 21, 23, 26, 36 AND 38). SN 85-396,769. PUB. 1-10-2012. FILED 8-12-2011.
- 4,118,622. **BUSWORKS (STANDARD CHARACTER)**. ACROMAG INCORPORATED, (U.S. CLS. 21, 23, 26, 36 AND 38). SN 85-396,822. PUB. 1-10-2012. FILED 8-12-2011.
- 4,118,629. **INTELLIPACK (STANDARD CHARACTER)**. ACROMAG INCORPORATED, (U.S. CLS. 21, 23, 26, 36 AND 38). SN 85-396,884. PUB. 1-10-2012. FILED 8-12-2011.
- 4,118,641. **RELIABLE CRITICAL LIFELINES (STANDARD CHARACTER)**. IRIDIUM SATELLITE LLC, MULTIPLE CLASS, (INT. CLS. 9 AND 38), (U.S. CLS. 21, 23, 26, 36, 38, 100, 101 AND 104). SN 85-397,043. PUB. 1-10-2012. FILED 8-12-2011.
- 4,118,642. **HELI-AWESOME! (STANDARD CHARACTER)**. NAMCO BANDAI GAMES AMERICA INC., (U.S. CLS. 21, 23, 26, 36 AND 38). SN 85-397,049. PUB. 1-10-2012. FILED 8-12-2011.
- 4,118,683. **SINGFIT (STANDARD CHARACTER)**. U-SING, (U.S. CLS. 21, 23, 26, 36 AND 38). SN 85-407,282. PUB. 1-10-2012. FILED 8-25-2011.
- 4,118,690. **BUSINESSSTHINK (STANDARD CHARACTER)**. AVISOD LLC, (U.S. CLS. 21, 23, 26, 36 AND 38). SN 85-411,148. PUB. 1-10-2012. FILED 8-30-2011.
- 4,118,702 (*See Class 7 for this trademark*).
- 4,118,711. **MAP IT. DISCOVER & EXPLORE! (STANDARD CHARACTER)**. PARKSBYNATURE NETWORK, LLC, (U.S. CLS. 21, 23, 26, 36 AND 38). SN 85-430,631. PUB. 1-10-2012. FILED 9-23-2011.
- 4,118,725. **DOS HOGARES (STANDARD CHARACTER)**. TEL-EVISA, S.A. DE C.V., MULTIPLE CLASS, (INT. CLS. 9 AND 41), (U.S. CLS. 21, 23, 26, 36, 38, 100, 101 AND 107). SN 85-445,145. PUB. 1-10-2012. FILED 10-12-2011.

CLASS 10—MEDICAL APPARATUS

- 4,116,590. **ENDOFLIP (STANDARD CHARACTER)**. FLIP TECHNOLOGIES LIMITED, (U.S. CLS. 26, 39 AND 44). SN 77-172,827. PUB. 1-10-2012. FILED 5-4-2007.
- 4,116,650 (*See Class 7 for this trademark*).
- 4,116,651 (*See Class 7 for this trademark*).
- 4,116,652 (*See Class 7 for this trademark*).
- 4,116,653 (*See Class 7 for this trademark*).
- 4,116,685. **EXAMION (STANDARD CHARACTER)**. DIX-RAY SOLUTION GMBH, MULTIPLE CLASS, (INT. CLS. 10 AND 44), (U.S. CLS. 26, 39, 44, 100 AND 101). SN 79-078,050. PUB. 1-10-2012. FILED 11-18-2009.
- 4,116,712. **A CTMM PROJECT AND DESIGN**. STICHTING CENTER FOR TRANSLATIONAL MOLECULAR MEDICINE, MULTIPLE CLASS, (INT. CLS. 10, 35, 36, 41 AND 42), (U.S. CLS. 26, 39, 44, 100, 101, 102 AND 107). SN 79-088,334. PUB. 1-10-2012. FILED 7-28-2010.
- 4,116,716. **CUFITEC (STYLIZED)**. NBC MESHTEC INC., MULTIPLE CLASS, (INT. CLS. 10, 11, 24 AND 25), (U.S. CLS. 13, 21, 22, 23, 26, 31, 34, 39, 42, 44 AND 50). SN 79-090,007. PUB. 1-10-2012. FILED 7-7-2010.
- 4,116,718. **CTMM (STANDARD CHARACTER)**. STICHTING CENTER FOR TRANSLATIONAL MOLECULAR MEDICINE, MULTIPLE CLASS, (INT. CLS. 10, 35, 36, 41 AND 42), (U.S. CLS. 26, 39, 44, 100, 101, 102 AND 107). SN 79-090,189. PUB. 1-10-2012. FILED 7-28-2010.
- 4,116,810. **SECOND HEART (STANDARD CHARACTER)**. AD

- REM TECHNOLOGY, (U.S. CLS. 26, 39 AND 44). SN 79-099,167. PUB. 1-10-2012. FILED 6-13-2011.
- 4,116,842. **PROFUNDUS IMAGING (STYLIZED)**. EXOMED AB, (U.S. CLS. 26, 39 AND 44). SN 79-100,824. PUB. 1-10-2012. FILED 6-29-2011.
- 4,116,851. **MULTIX SELECT (STANDARD CHARACTER)**. SIEMENS AKTIENGESSELLSCHAFT, (U.S. CLS. 26, 39 AND 44). SN 79-101,731. PUB. 1-10-2012. FILED 7-20-2011.
- 4,116,852 (*See Class 5 for this trademark*).
- 4,116,885 (*See Class 9 for this trademark*).
- 4,116,970. **DYNA-MASK (STANDARD CHARACTER)**. DYNAMIC ADSORBENTS, INC., (U.S. CLS. 26, 39 AND 44). SN 85-155,056. PUB. 1-10-2012. FILED 10-18-2010.
- 4,116,971. **DYNA MASK AND DESIGN**. DYNAMIC ADSORBENTS, INC., (U.S. CLS. 26, 39 AND 44). SN 85-155,067. PUB. 1-10-2012. FILED 10-18-2010.
- 4,116,974 (*See Class 9 for this trademark*).
- 4,116,975. **MISCELLANEOUS DESIGN**. JORDCO, INC., (U.S. CLS. 26, 39 AND 44). SN 85-161,796. PUB. 1-10-2012. FILED 10-26-2010.
- 4,116,976. **MISCELLANEOUS DESIGN**. JORDCO, INC., (U.S. CLS. 26, 39 AND 44). SN 85-161,798. PUB. 1-10-2012. FILED 10-26-2010.
- 4,116,981. **PROPULSE (STANDARD CHARACTER)**. MIRAGE HEALTH GROUP LIMITED, (U.S. CLS. 26, 39 AND 44). SN 85-168,809. PUB. 1-10-2012. FILED 11-4-2010.
- 4,116,997. **ONE HEARTBEAT AHEAD (STANDARD CHARACTER)**. EUROCOR GMBH, MULTIPLE CLASS, (INT. CLS. 10, 40 AND 42), (U.S. CLS. 26, 39, 44, 100, 101, 103 AND 106). SN 85-188,048. PUB. 1-10-2012. FILED 12-1-2010.
- 4,117,205. **L'AMOUR (STANDARD CHARACTER)**. CALIFORNIA EXOTIC NOVELTIES, LLC, (U.S. CLS. 26, 39 AND 44). SN 85-241,483. PUB. 1-10-2012. FILED 2-14-2011.
- 4,117,389. **TEN SHOOTER (STANDARD CHARACTER)**. COOK MEDICAL TECHNOLOGIES LLC, (U.S. CLS. 26, 39 AND 44). SN 85-281,262. PUB. 1-10-2012. FILED 3-30-2011.
- 4,117,390. **FOUR SHOOTER (STANDARD CHARACTER)**. COOK MEDICAL TECHNOLOGIES LLC, (U.S. CLS. 26, 39 AND 44). SN 85-281,272. PUB. 1-10-2012. FILED 3-30-2011.
- 4,117,536. **THE BLANKET BAR BY ROYAL INNOVATIONS AND DESIGN**. ROYAL INNOVATIONS, LLC, (U.S. CLS. 26, 39 AND 44). SN 85-310,327. PUB. 1-10-2012. FILED 5-2-2011.
- 4,117,553. **IMMCO DIAGNOSTICS AND DESIGN**. IMMCO DIAGNOSTICS, INC., (U.S. CLS. 26, 39 AND 44). SN 85-314,467. PUB. 1-10-2012. FILED 5-6-2011.
- 4,117,599. **ATEX TECHNOLOGIES INC (STANDARD CHARACTER)**. ATEX TECHNOLOGIES, INC., (U.S. CLS. 26, 39 AND 44). SN 85-324,154. PUB. 1-10-2012. FILED 5-18-2011.
- 4,117,633. **ECHELON OVAL (STANDARD CHARACTER)**. HITACHI MEDICAL CORPORATION, (U.S. CLS. 26, 39 AND 44). SN 85-330,619. PUB. 1-10-2012. FILED 5-26-2011.
- 4,117,704 (*See Class 5 for this trademark*).
- 4,117,796. **POINTS OF INTRIGUE (STANDARD CHARACTER)**. A.L. ENTERPRISES, INC., (U.S. CLS. 26, 39 AND 44). SN 85-357,995. PUB. 1-10-2012. FILED 6-28-2011.
- 4,117,887 (*See Class 5 for this trademark*).
- 4,117,934. **BUBBLE-BLOC (STANDARD CHARACTER)**. ARMSTRONG MEDICAL LIMITED, (U.S. CLS. 26, 39 AND 44). SN 85-369,084. PUB. 1-10-2012. FILED 7-12-2011.
- 4,117,939. **BUBBLE-PLATE (STANDARD CHARACTER)**. ARMSTRONG MEDICAL LIMITED, (U.S. CLS. 26, 39 AND 44). SN 85-369,286. PUB. 1-10-2012. FILED 7-12-2011.
- 4,117,945 (*See Class 5 for this trademark*).
- 4,118,098. **TALON SYSTEM AND DESIGN**. OMNI SURGICAL, LLC, DBA SPINE360, (U.S. CLS. 26, 39 AND 44). SN 85-374,298. PUB. 1-10-2012. FILED 7-18-2011.
- 4,118,099. **SERPENT TALON LONG CANNULATED SYSTEM AND DESIGN**. OMNI SURGICAL, LLC, DBA SPINE360, (U.S. CLS. 26, 39 AND 44). SN 85-374,324. PUB. 1-10-2012. FILED 7-18-2011.
- 4,118,101. **BARRACUDA ANTERIOR CERVICAL PLATE SYSTEM AND DESIGN**. OMNI SURGICAL, LLC, DBA SPINE360, (U.S. CLS. 26, 39 AND 44). SN 85-374,344. PUB. 1-10-2012. FILED 7-18-2011.
- 4,118,153. **HI-RES (STANDARD CHARACTER)**. GOLDBERG, ELLIOTT, (U.S. CLS. 26, 39 AND 44). SN 85-375,393. PUB. 1-10-2012. FILED 7-19-2011.
- 4,118,154. **LITE (STANDARD CHARACTER)**. GOLDBERG, ELLIOTT, (U.S. CLS. 26, 39 AND 44). SN 85-375,405. PUB. 1-10-2012. FILED 7-19-2011.
- 4,118,306. **POINT RELIEF (STANDARD CHARACTER)**. GOLDBERG, ELLIOTT, (U.S. CLS. 26, 39 AND 44). SN 85-384,135. PUB. 1-10-2012. FILED 7-28-2011.
- 4,118,388. **NOBLE TOUCH (STANDARD CHARACTER)**. BLACK & BLACK SURGICAL, INC., (U.S. CLS. 26, 39 AND 44). SN 85-391,942. PUB. 1-10-2012. FILED 8-8-2011.
- 4,118,414. **MISCELLANEOUS DESIGN**. CID RESOURCES, INC., (U.S. CLS. 26, 39 AND 44). SN 85-392,566. PUB. 1-10-2012. FILED 8-8-2011.
- 4,118,654. **AALIGNER (STANDARD CHARACTER)**. ARRUDA, AIRTON O, (U.S. CLS. 26, 39 AND 44). SN 85-397,246. PUB. 1-10-2012. FILED 8-12-2011.
-
- CLASS 11—ENVIRONMENTAL CONTROL APPARATUS**
- 4,116,559. **RLS LIGHTING, INC. AND DESIGN**. RLS LIGHTING INC, (U.S. CLS. 13, 21, 23, 31 AND 34). SN 76-703,414. PUB. 1-10-2012. FILED 6-17-2010.
- 4,116,567. **CSAFE (STANDARD CHARACTER)**. CSAFEE, LLC, (U.S. CLS. 13, 21, 23, 31 AND 34). SN 76-706,169. PUB. 1-10-2012. FILED 1-28-2011.
- 4,116,585 (*See Class 8 for this trademark*).
- 4,116,586. **UP3 (STANDARD CHARACTER)**. SENNINGER IRRIGATION INC., (U.S. CLS. 13, 21, 23, 31 AND 34). SN 76-708,656. PUB. 1-10-2012. FILED 8-8-2011.
- 4,116,633. **MELODY (STANDARD CHARACTER)**. SOCIETE DES PRODUITS NESTLE S.A., (U.S. CLS. 13, 21, 23, 31 AND 34). SN 77-833,321. PUB. 1-10-2012. FILED 9-23-2009.
- 4,116,650 (*See Class 7 for this trademark*).
- 4,116,651 (*See Class 7 for this trademark*).
- 4,116,652 (*See Class 7 for this trademark*).
- 4,116,653 (*See Class 7 for this trademark*).
- 4,116,678 (*See Class 1 for this trademark*).
- 4,116,703 (*See Class 8 for this trademark*).
- 4,116,716 (*See Class 10 for this trademark*).
- 4,116,741 (*See Class 3 for this trademark*).
- 4,116,742 (*See Class 3 for this trademark*).
- 4,116,743. **KEY-MEMBRAN, KEY-MEMBRANE (STANDARD CHARACTER)**. ENSWICO IP AG, (U.S. CLS. 13, 21, 23, 31 AND 34). SN 79-094,908. PUB. 1-10-2012. FILED 3-3-2011.
- 4,116,744. **KEY-ADAPTER (STANDARD CHARACTER)**. ENSWICO IP AG, (U.S. CLS. 13, 21, 23, 31 AND 34). SN 79-094,909. PUB. 1-10-2012. FILED 3-3-2011.
- 4,116,755. **VERTICAL CHEF AND DESIGN**. R.B. MARKETING SRL UNIPERSONALE, (U.S. CLS. 13, 21, 23, 31 AND 34). SN 79-095,505. PUB. 1-10-2012. FILED 2-9-2011.
- 4,116,761 (*See Class 7 for this trademark*).
- 4,116,786. **GROHE EASYREACH (STANDARD CHARACTER)**. GROHE AG, (U.S. CLS. 13, 21, 23, 31 AND 34). SN 79-097,325. PUB. 1-10-2012. FILED 4-15-2011.
- 4,116,804. **PIETER ADAM (STANDARD CHARACTER)**. V.O.F. "LUMIÈRE", (U.S. CLS. 13, 21, 23, 31 AND 34). SN 79-098,794. PUB. 1-10-2012. FILED 2-3-2011.
- 4,116,814. **COWAY (STYLIZED)**. WOONGJIN COWAY CO., LTD., (U.S. CLS. 13, 21, 23, 31 AND 34). SN 79-099,404. PUB. 1-10-2012. FILED 5-24-2011.
- 4,116,841 (*See Class 7 for this trademark*).
- 4,116,886. **POOLEX (STANDARD CHARACTER)**. ARBI, JANEZ, (U.S. CLS. 13, 21, 23, 31 AND 34). SN 85-038,902. PUB. 1-10-2012. FILED 5-14-2010.
- 4,116,888. **SMC THERMO DRYER (STANDARD CHARACTER)**. SMC CORPORATION, (U.S. CLS. 13, 21, 23, 31 AND 34). SN 85-042,691. PUB. 1-10-2012. FILED 5-19-2010.
- 4,116,889 (*See Class 9 for this trademark*).
- 4,116,904 (*See Class 9 for this trademark*).
- 4,116,907. **MALIBU (STANDARD CHARACTER)**. J. BAXTER BRINKMANN INTERNATIONAL CORPORATION, (U.S. CLS. 13, 21, 23, 31 AND 34). SN 85-077,489. PUB. 1-10-2012. FILED 7-2-2010.
- 4,116,983 (*See Class 1 for this trademark*).
- 4,117,035. **FIVE-SENSE (STANDARD CHARACTER)**. PUZHEN LIFE CO., LIMITED, (U.S. CLS. 13, 21, 23, 31 AND

- 34). SN 85-208,126. PUB. 1-10-2012. FILED 12-30-2010.
4,117,048 (*See Class 6 for this trademark*).
- 4,117,260. **FOLDAWAY (STANDARD CHARACTER)**. NATIONAL PRESTO INDUSTRIES, INC., (U.S. CLS. 13, 21, 23, 31 AND 34). SN 85-251,617. PUB. 1-10-2012. FILED 2-25-2011.
- 4,117,299. **LIFE IN VILLA AND DESIGN**. GLORY HOLDING LIMITED, MULTIPLE CLASS, (INT. CLS. 11 AND 19), (U.S. CLS. 1, 12, 13, 21, 23, 31, 33, 34 AND 50). SN 85-260,380. PUB. 1-10-2012. FILED 3-7-2011.
- 4,117,300. **BARACAN AND DESIGN**. GLORY HOLDING LIMITED, (U.S. CLS. 13, 21, 23, 31 AND 34). SN 85-260,396. PUB. 1-10-2012. FILED 3-7-2011.
- 4,117,301. **GLORIOUS AND DESIGN**. GLORY HOLDING LIMITED, (U.S. CLS. 13, 21, 23, 31 AND 34). SN 85-260,404. PUB. 1-10-2012. FILED 3-7-2011.
- 4,117,326. **TREE T-PEE AND DESIGN**. TREE T PEE, LLC, (U.S. CLS. 13, 21, 23, 31 AND 34). SN 85-267,077. PUB. 1-10-2012. FILED 3-15-2011.
- 4,117,378 (*See Class 9 for this trademark*).
- 4,117,651 (*See Class 7 for this trademark*).
- 4,117,685. **HYDROVANTAGE (STANDARD CHARACTER)**. ZURN INDUSTRIES, LLC, (U.S. CLS. 13, 21, 23, 31 AND 34). SN 85-341,042. PUB. 1-10-2012. FILED 6-8-2011.
- 4,117,792. **CL FREE WATER SYSTEMS AND DESIGN**. CL FREE WATER SYSTEMS, LLC, (U.S. CLS. 13, 21, 23, 31 AND 34). SN 85-357,403. PUB. 1-10-2012. FILED 6-27-2011.
- 4,117,798. **SMOKE-SCREENS (STANDARD CHARACTER)**. J. HOWARD, LLC, (U.S. CLS. 13, 21, 23, 31 AND 34). SN 85-358,247. PUB. 1-10-2012. FILED 6-28-2011.
- 4,117,819. **THERMACTIVE ELECTRONICS AND DESIGN**. THERMACTIVE ELECTRONICS LLC, (U.S. CLS. 13, 21, 23, 31 AND 34). SN 85-360,260. PUB. 1-10-2012. FILED 6-30-2011.
- 4,117,825. **EZ VENT (STANDARD CHARACTER)**. EZ VENT, LLC, (U.S. CLS. 13, 21, 23, 31 AND 34). SN 85-360,795. PUB. 1-10-2012. FILED 6-30-2011.
- 4,117,846. **CHEFMAN (STANDARD CHARACTER)**. PLUS ITS CHEAP LLC, (U.S. CLS. 13, 21, 23, 31 AND 34). SN 85-364,214. PUB. 1-10-2012. FILED 7-6-2011.
- 4,117,969. **TACTICAL BY DESIGN (STANDARD CHARACTER)**. BRITE-STRIKE TECHNOLOGIES INC., (U.S. CLS. 13, 21, 23, 31 AND 34). SN 85-370,716. PUB. 1-10-2012. FILED 7-13-2011.
- 4,117,971. **DESIGNED BY POLICE OFFICERS, FOR POLICE OFFICERS (STANDARD CHARACTER)**. BRITE-STRIKE TECHNOLOGIES INC., (U.S. CLS. 13, 21, 23, 31 AND 34). SN 85-370,756. PUB. 1-10-2012. FILED 7-13-2011.
- 4,118,111. **SELECT LIGHTING SOLUTIONS AND DESIGN**. CITY ELECTRIC SUPPLY CO., (U.S. CLS. 13, 21, 23, 31 AND 34). SN 85-374,612. PUB. 1-10-2012. FILED 7-19-2011.
- 4,118,294 (*See Class 3 for this trademark*).
- 4,118,302. **APALS (STANDARD CHARACTER)**. BRITE-STRIKE TECHNOLOGIES INC., (U.S. CLS. 13, 21, 23, 31 AND 34). SN 85-382,819. PUB. 1-10-2012. FILED 7-27-2011.
- 4,118,312. **UN-EDISON (STANDARD CHARACTER)**. STIMULUS BRANDS LLC, (U.S. CLS. 13, 21, 23, 31 AND 34). SN 85-386,761. PUB. 1-10-2012. FILED 8-2-2011.
- 4,118,653. **OG (STANDARD CHARACTER)**. GROWLITE, INC., (U.S. CLS. 13, 21, 23, 31 AND 34). SN 85-397,205. PUB. 1-10-2012. FILED 8-12-2011.
- 4,118,666. **CIRQUA (STANDARD CHARACTER)**. BEEMAN, DAVID RODNEY, MULTIPLE CLASS, (INT. CLS. 11 AND 32), (U.S. CLS. 13, 21, 23, 31, 34, 45, 46 AND 48). SN 85-399,012. PUB. 1-10-2012. FILED 8-16-2011.
- 4,118,702 (*See Class 7 for this trademark*).
- 4,118,710. **THE HARVESTING RAINWATER COLANDER (STANDARD CHARACTER)**. AMERIMAX HOME PRODUCTS, INC., (U.S. CLS. 13, 21, 23, 31 AND 34). SN 85-429,892. PUB. 1-10-2012. FILED 9-22-2011.
- PUB. 1-10-2012. FILED 12-29-2005.
- 4,116,672. **PHENOM 100 (STANDARD CHARACTER)**. EM-BRAER - EMPRESA BRASILEIRA DE AERONAUTICA S.A., (U.S. CLS. 19, 21, 23, 31, 35 AND 44). SN 78-782,101. PUB. 1-10-2012. FILED 12-29-2005.
- 4,116,720. **NAIBA AND DESIGN**. ZHEJIANG NAIBA PUMP CO., LTD., (U.S. CLS. 19, 21, 23, 31, 35 AND 44). SN 79-090,762. PUB. 1-10-2012. FILED 11-23-2010.
- 4,116,736 (*See Class 9 for this trademark*).
- 4,116,738. **MAGIQ (STANDARD CHARACTER)**. CURANA INVEST BVBA, (U.S. CLS. 19, 21, 23, 31, 35 AND 44). SN 79-094,646. PUB. 1-10-2012. FILED 1-26-2011.
- 4,116,745. **BMW I3 (STANDARD CHARACTER)**. BAYERISCHE MOTOREN WERKE AKTIENGESELLSCHAFT, (U.S. CLS. 19, 21, 23, 31, 35 AND 44). SN 79-094,960. PUB. 1-10-2012. FILED 1-27-2011.
- 4,116,752 (*See Class 7 for this trademark*).
- 4,116,761 (*See Class 7 for this trademark*).
- 4,116,818 (*See Class 6 for this trademark*).
- 4,116,845. **REWAVE (STANDARD CHARACTER)**. S.C.P 3 MAD MEN, MULTIPLE CLASS, (INT. CLS. 12, 25 AND 41), (U.S. CLS. 19, 21, 22, 23, 31, 35, 39, 44, 100, 101 AND 107). SN 79-101,032. PUB. 1-10-2012. FILED 6-20-2011.
- 4,116,858. **PP AND DESIGN**. PIRELLI & C. S.P.A., (U.S. CLS. 19, 21, 23, 31, 35 AND 44). SN 79-102,263. PUB. 1-10-2012. FILED 6-21-2011.
- 4,116,865 (*See Class 7 for this trademark*).
- 4,116,868. **MISCELLANEOUS DESIGN**. SANY GROUP CO., LTD., (U.S. CLS. 19, 21, 23, 31, 35 AND 44). SN 79-104,353. PUB. 1-10-2012. FILED 8-2-2011.
- 4,116,926 (*See Class 9 for this trademark*).
- 4,116,927 (*See Class 9 for this trademark*).
- 4,116,957. **TUSK (STANDARD CHARACTER)**. ROCKY MOUNTAIN ATV, INC., (U.S. CLS. 19, 21, 23, 31, 35 AND 44). SN 85-135,430. PUB. 1-10-2012. FILED 9-22-2010.
- 4,117,391. **WALKABOUT (STANDARD CHARACTER)**. SKY-LINE CORPORATION, (U.S. CLS. 19, 21, 23, 31, 35 AND 44). SN 85-281,359. PUB. 1-10-2012. FILED 3-30-2011.
- 4,117,563. **TALON TIGHT AND DESIGN**. LES ACIERS ROBOND INC., (U.S. CLS. 19, 21, 23, 31, 35 AND 44). SN 85-317,683. PUB. 10-4-2011. FILED 5-11-2011.
- 4,117,602. **GAVIA (STANDARD CHARACTER)**. TELEDYNE GAVIA EHF, FORMERLY HAFMYND EHF, (U.S. CLS. 19, 21, 23, 31, 35 AND 44). SN 85-324,358. PUB. 1-10-2012. FILED 5-18-2011.
- 4,117,621. **ALTA SYSTEMS (STANDARD CHARACTER)**. CIAMPA, JOHN A., DBA ALTA SYSTEMS, MULTIPLE CLASS, (INT. CLS. 12 AND 41), (U.S. CLS. 19, 21, 23, 31, 35, 44, 100, 101 AND 107). SN 85-327,559. PUB. 1-10-2012. FILED 5-23-2011.
- 4,117,920. **ARM-R-SAFE (STANDARD CHARACTER)**. AIR-CRAFT RUBBER MANUFACTURING, INC., (U.S. CLS. 19, 21, 23, 31, 35 AND 44). SN 85-368,452. PUB. 1-10-2012. FILED 7-11-2011.
- 4,118,249. **X2 (STANDARD CHARACTER)**. SIKORSKY AIR-CRAFT CORPORATION, (U.S. CLS. 19, 21, 23, 31, 35 AND 44). SN 85-378,581. PUB. 1-10-2012. FILED 7-22-2011.
- 4,118,294 (*See Class 3 for this trademark*).
- 4,118,311. **TACTICS (STANDARD CHARACTER)**. EFUEGO CORP., (U.S. CLS. 19, 21, 23, 31, 35 AND 44). SN 85-385,948. PUB. 1-10-2012. FILED 8-1-2011.
- 4,118,384. **SNAP BMX PRODUCTS (STYLIZED)**. G.A.W. INDUSTRIES, INC., (U.S. CLS. 19, 21, 23, 31, 35 AND 44). SN 85-391,798. PUB. 1-10-2012. FILED 8-8-2011.
- 4,118,415. **SUNMOBILE AND DESIGN**. SOLARCART SOLUTIONS, (U.S. CLS. 19, 21, 23, 31, 35 AND 44). SN 85-392,580. PUB. 1-10-2012. FILED 8-8-2011.
- 4,118,513. **B-POD (STANDARD CHARACTER)**. ROCKCONCEPTS, INC., (U.S. CLS. 19, 21, 23, 31, 35 AND 44). SN 85-394,482. PUB. 1-10-2012. FILED 8-10-2011.
- 4,118,564. **FUN CHASER (STYLIZED)**. CAROLINA SKIFF, LLC, (U.S. CLS. 19, 21, 23, 31, 35 AND 44). SN 85-395,484. PUB. 1-10-2012. FILED 8-11-2011.
- 4,118,636. **ALUMATECH (STANDARD CHARACTER)**. TRAVIS BODY & TRAILER, INC., (U.S. CLS. 19, 21, 23, 31, 35 AND 44). SN 85-396,967. PUB. 1-10-2012. FILED 8-12-2011.
- 4,118,638. **ALUMATECH AND DESIGN**. TRAVIS BODY & TRAILER, INC., (U.S. CLS. 19, 21, 23, 31, 35 AND 44). SN 85-

CLASS 12—VEHICLES

- 4,116,671. **PHENOM 300 (STANDARD CHARACTER)**. EM-BRAER - EMPRESA BRASILEIRA DE AERONAUTICA S.A., (U.S. CLS. 19, 21, 23, 31, 35 AND 44). SN 78-782,100.

- 397,019. PUB. 1-10-2012. FILED 8-12-2011.
 4,118,695. **HUFFY (STANDARD CHARACTER)**. HUFFY CORPORATION, (U.S. CLS. 19, 21, 23, 31, 35 AND 44). SN 85-418,715. PUB. 1-10-2012. FILED 9-9-2011.
 4,118,701. **H AND DESIGN**. HANDSOME CYCLES, LLC, (U.S. CLS. 19, 21, 23, 31, 35 AND 44). SN 85-425,553. PUB. 1-10-2012. FILED 9-18-2011.

CLASS 13—FIREARMS

- 4,116,823. **KX-6 (STANDARD CHARACTER)**. H. KRIEGHOFF GMBH, (U.S. CLS. 2 AND 9). SN 79-099,930. PUB. 1-10-2012. FILED 3-8-2011.
 4,117,160 (*See Class 8 for this trademark*).
 4,117,228. **SLINGBACK (STANDARD CHARACTER)**. HANBERG, ANTHONY OWEN, (U.S. CLS. 2 AND 9). SN 85-245,657. PUB. 1-10-2012. FILED 2-18-2011.
 4,118,291. **RGS BRAND FIREWORKS THE REALLY GOOD STUFF AND DESIGN**. HISLE, MARK E., (U.S. CLS. 2 AND 9). SN 85-380,959. PUB. 1-10-2012. FILED 7-26-2011.
 4,118,724. **MOE-K (STANDARD CHARACTER)**. MAGPUL INDUSTRIES CORP., (U.S. CLS. 2 AND 9). SN 85-443,748. PUB. 1-10-2012. FILED 10-10-2011.

CLASS 14—JEWELRY

- 4,116,754. **J.F. BAUTTE & CIE (STYLIZED)**. SOWIND S.A. (SOWIND A.G.) (SOWIND LTD), (U.S. CLS. 2, 27, 28 AND 50). SN 79-095,394. PUB. 1-10-2012. FILED 3-14-2011.
 4,116,757 (*See Class 9 for this trademark*).
 4,116,759 (*See Class 9 for this trademark*).
 4,116,768 (*See Class 3 for this trademark*).
 4,116,813. **SPHEROTOURBILLON (STANDARD CHARACTER)**. RICHEMONT INTERNATIONAL SA. (U.S. CLS. 2, 27, 28 AND 50). SN 79-099,401. PUB. 1-10-2012. FILED 5-31-2011.
 4,116,821 (*See Class 6 for this trademark*).
 4,116,822. **TUDOR FASTRIDER (STANDARD CHARACTER)**. MONTRES TUDOR SA. (U.S. CLS. 2, 27, 28 AND 50). SN 79-099,918. PUB. 1-10-2012. FILED 6-27-2011.
 4,116,849. **LO AND LO (STANDARD CHARACTER)**. BIJA LAURENT, (U.S. CLS. 2, 27, 28 AND 50). SN 79-101,291. PUB. 1-10-2012. FILED 4-11-2011.
 4,116,861. **TUDOR WATCH YOUR STYLE AND DESIGN**. MONTRES TUDOR SA. (U.S. CLS. 2, 27, 28 AND 50). SN 79-102,426. PUB. 1-10-2012. FILED 8-2-2011.
 4,116,905. **VAGOS M C AND DESIGN**. VAGOS INTERNATIONAL MOTORCYCLE CLUB, MULTIPLE CLASS, (INT. CLS. 14, 25, 26 AND 41), (U.S. CLS. 2, 22, 27, 28, 37, 39, 40, 42, 50, 100, 101 AND 107). SN 85-076,951. PUB. 1-10-2012. FILED 7-2-2010.
 4,116,918. **NOKOMIS (STANDARD CHARACTER)**. ANTOFAGASTA MINERALS S.A., (U.S. CLS. 2, 27, 28 AND 50). SN 85-094,201. PUB. 1-10-2012. FILED 7-27-2010.
 4,116,928. **DISTINGUISHED YOUNG WOMEN SCHOLARSHIP LEADERSHIP TALENT AND DESIGN**. AMERICA'S JUNIOR MISS PROGRAM, INC., MULTIPLE CLASS, (INT. CLS. 14 AND 25), (U.S. CLS. 2, 22, 27, 28, 39 AND 50). SN 85-100,924. PUB. 1-10-2012. FILED 8-5-2010.
 4,116,944. **MILLER'S FASHION CLUB (STANDARD CHARACTER)**. SPECIALTY FASHION GROUP LTD, MULTIPLE CLASS, (INT. CLS. 14, 25 AND 35), (U.S. CLS. 2, 22, 27, 28, 39, 50, 100, 101 AND 102). SN 85-122,878. PUB. 1-10-2012. FILED 9-3-2010.
 4,117,018. **METALSMITHS STERLING (STANDARD CHARACTER)**. 1400446 ALBERTA LTD., (U.S. CLS. 2, 27, 28 AND 50). SN 85-199,257. PUB. 1-10-2012. FILED 12-16-2010.
 4,117,072. **N AND DESIGN**. NOMIKI GLYNATIS COUTURE PTY LTD, MULTIPLE CLASS, (INT. CLS. 14 AND 25), (U.S. CLS. 2, 22, 27, 28, 39 AND 50). SN 85-221,295. PUB. 1-10-2012. FILED 1-19-2011.
 4,117,424. **BALFOUR SPORTS (STANDARD CHARACTER)**. COMMEMORATIVE BRANDS, INC., (U.S. CLS. 2, 27, 28

- AND 50). SN 85-288,248. PUB. 1-10-2012. FILED 4-6-2011.
 4,117,465. **IT'S TIME TO FACE THE MUSIC (STANDARD CHARACTER)**. FREMANTLEMEDIA LIMITED, AND SIMCO LIMITED, (U.S. CLS. 2, 27, 28 AND 50). SN 85-295,186. PUB. 1-10-2012. FILED 4-14-2011.
 4,117,554. **WF WEST FORCE AND DESIGN**. WEST FORCE USA INC., (U.S. CLS. 2, 27, 28 AND 50). SN 85-314,468. PUB. 1-10-2012. FILED 5-6-2011.
 4,117,608. **CHRISTINA COLLECTION (STANDARD CHARACTER)**. EASTERN NATIONWIDE SUPPLY, INC., (U.S. CLS. 2, 27, 28 AND 50). SN 85-325,135. PUB. 1-10-2012. FILED 5-19-2011.
 4,117,674. **RS RIMA SATER (STYLIZED)**. RIMA SATER, LLC, DBA RIMA SATER, MULTIPLE CLASS, (INT. CLS. 14 AND 35), (U.S. CLS. 2, 27, 28, 50, 100, 101 AND 102). SN 85-338,466. PUB. 1-10-2012. FILED 6-6-2011.
 4,117,728. **AQUA PRINCESS (STANDARD CHARACTER)**. THE PLUMERIA TREE, LLC, (U.S. CLS. 2, 27, 28 AND 50). SN 85-349,098. PUB. 1-10-2012. FILED 6-17-2011.
 4,117,742 (*See Class 3 for this trademark*).
 4,117,750. **EMMA GARNETT JEWELRY (STANDARD CHARACTER)**. GRUBB, BETH NALLEY, DBA EMMA GARNETT JEWELRY, (U.S. CLS. 2, 27, 28 AND 50). SN 85-351,721. PUB. 1-10-2012. FILED 6-21-2011.
 4,117,763. **ETERNITY NATURAL EMERALDS (STANDARD CHARACTER)**. ARTHUR GROOM & CO., INC., (U.S. CLS. 2, 27, 28 AND 50). SN 85-353,547. PUB. 1-10-2012. FILED 6-22-2011.
 4,117,799. **HELP ON THE HOMEFRONT (STANDARD CHARACTER)**. PATRIOT GUARD RIDERS, INC., MULTIPLE CLASS, (INT. CLS. 14, 36 AND 45), (U.S. CLS. 2, 27, 28, 50, 100, 101 AND 102). SN 85-358,256. PUB. 1-10-2012. FILED 6-28-2011.
 4,117,964. **FOXY FEATHERS (STANDARD CHARACTER)**. FOXY FEATHERS, LLC, MULTIPLE CLASS, (INT. CLS. 14 AND 26), (U.S. CLS. 2, 27, 28, 37, 39, 40, 42 AND 50). SN 85-370,515. PUB. 1-10-2012. FILED 7-13-2011.
 4,118,271. **TALBOTS (STANDARD CHARACTER)**. TALBOTS GROUP, LIMITED PARTNERSHIP, THE, MULTIPLE CLASS, (INT. CLS. 14, 18, 25 AND 35), (U.S. CLS. 1, 2, 3, 22, 27, 28, 39, 41, 50, 100, 101 AND 102). SN 85-380,026. PUB. 1-10-2012. FILED 7-25-2011.
 4,118,324. **INVICTA TERRA (STANDARD CHARACTER)**. INVICTA WATCH COMPANY OF AMERICA, INC., (U.S. CLS. 2, 27, 28 AND 50). SN 85-387,892. PUB. 1-10-2012. FILED 8-3-2011.
 4,118,480. **WEAR THEIR STORY (STANDARD CHARACTER)**. DIVINE INHERITANCE, INC., (U.S. CLS. 2, 27, 28 AND 50). SN 85-393,767. PUB. 1-10-2012. FILED 8-9-2011.
 4,118,563. **ESSN (STANDARD CHARACTER)**. YEUNG, JULIE C., (U.S. CLS. 2, 27, 28 AND 50). SN 85-395,477. PUB. 1-10-2012. FILED 8-11-2011.
 4,118,571. **ANDE AND DESIGN**. YEUNG, JULIE C., (U.S. CLS. 2, 27, 28 AND 50). SN 85-395,723. PUB. 1-10-2012. FILED 8-11-2011.
 4,118,746. **PB POWER BALANCE PERFORMANCE TECHNOLOGY AND DESIGN**. POWER BALANCE, LLC, MULTIPLE CLASS, (INT. CLS. 14 AND 16), (U.S. CLS. 2, 5, 22, 23, 27, 28, 29, 37, 38 AND 50). SN 85-975,959. PUB. 1-10-2012. FILED 4-30-2010.

CLASS 15—MUSICAL INSTRUMENTS

- 4,116,959. **X8 X8 DRUMS PUT YOUR HANDS ON ONE! AND DESIGN**. X8 DRUMS & PERCUSSION, INC., AND MARK A. STANCATO, AND KRISTIN R. STANCATO, (U.S. CLS. 2, 21 AND 36). SN 85-138,047. PUB. 1-10-2012. FILED 9-24-2010.
 4,117,036. **FRET SELECT ONE TOUCH NAVIGATION AND DESIGN**. INSPIRED INSTRUMENTS, INC., (U.S. CLS. 2, 21 AND 36). SN 85-208,446. PUB. 1-10-2012. FILED 12-31-2010.
 4,118,453. **CROSSROCK AND DESIGN**. CROSSROCK CASE COMPANY, (U.S. CLS. 2, 21 AND 36). SN 85-393,300. PUB. 1-10-2012. FILED 8-9-2011.
 4,118,601. **1ST LESSON (STANDARD CHARACTER)**. AMERICAN WAY MARKETING LLC, (U.S. CLS. 2, 21 AND 36).

SN 85-396,180. PUB. 1-10-2012. FILED 8-12-2011.
 4,118,749. **ON-STAGE (STANDARD CHARACTER)**. THE MUSIC PEOPLE INC., (U.S. CLS. 2, 21 AND 36). SN 85-976,268. PUB. 9-6-2011. FILED 4-5-2011.

CLASS 16—PAPER GOODS AND PRINTED MATTER

- 4,116,569. **UNIVERSITY OF HOUSTON (STANDARD CHARACTER)**. THE UNIVERSITY OF HOUSTON SYSTEM, MULTIPLE CLASS, (INT. CLS. 16, 25 AND 41), (U.S. CLS. 2, 5, 22, 23, 29, 37, 38, 39, 50, 100, 101 AND 107). SN 76-706,478. PUB. 1-10-2012. FILED 2-22-2011.
 4,116,585 (*See Class 8 for this trademark*).
 4,116,593 (*See Class 9 for this trademark*).
 4,116,606 (*See Class 9 for this trademark*).
 4,116,616. **FOOD ARTS (STANDARD CHARACTER)**. M. SHANKEN COMMUNICATIONS, INC., MULTIPLE CLASS, (INT. CLS. 16, 41 AND 43), (U.S. CLS. 2, 5, 22, 23, 29, 37, 38, 50, 100, 101 AND 107). SN 77-758,615. PUB. 1-10-2012. FILED 6-12-2009.
 4,116,669. **NOR CAL AND DESIGN**. NHS, INC., MULTIPLE CLASS, (INT. CLS. 16 AND 25), (U.S. CLS. 2, 5, 22, 23, 29, 37, 38, 39 AND 50). SN 78-236,106. PUB. 1-10-2012. FILED 4-10-2003.
 4,116,674 (*See Class 8 for this trademark*).
 4,116,678 (*See Class 1 for this trademark*).
 4,116,681 (*See Class 9 for this trademark*).
 4,116,683 (*See Class 6 for this trademark*).
 4,116,697 (*See Class 9 for this trademark*).
 4,116,700 (*See Class 9 for this trademark*).
 4,116,702. **GO APE! AND DESIGN**. ADVENTURE FOREST GROUP LIMITED, MULTIPLE CLASS, (INT. CLS. 16, 25, 41 AND 43), (U.S. CLS. 2, 5, 22, 23, 29, 37, 38, 39, 50, 100, 101 AND 107). SN 79-086,368. PUB. 1-10-2012. FILED 3-13-2010.
 4,116,707 (*See Class 8 for this trademark*).
 4,116,710. **THE BLANK SHEET PROJECT (STANDARD CHARACTER)**. ARJO WIGGINS FINE PAPERS LIMITED, MULTIPLE CLASS, (INT. CLS. 16, 35, 41 AND 45), (U.S. CLS. 2, 5, 22, 23, 29, 37, 38, 50, 100, 101, 102 AND 107). SN 79-087,945. PUB. 1-10-2012. FILED 9-14-2010.
 4,116,715. **MYSTIK (STANDARD CHARACTER)**. 3L-LUDVIGSEN A/S, (U.S. CLS. 2, 5, 22, 23, 29, 37, 38 AND 50). SN 79-089,458. PUB. 1-10-2012. FILED 6-24-2010.
 4,116,717. **JOLLY KIDZ (STANDARD CHARACTER)**. GLOBEWORKS PTY LTD, (U.S. CLS. 2, 5, 22, 23, 29, 37, 38 AND 50). SN 79-090,142. PUB. 1-10-2012. FILED 10-20-2010.
 4,116,725. **MISCELLANEOUS DESIGN**. MARIMEKKO OYJ, MULTIPLE CLASS, (INT. CLS. 16, 18, 21, 24 AND 25), (U.S. CLS. 1, 2, 3, 5, 13, 22, 23, 29, 30, 33, 37, 38, 39, 40, 41, 42 AND 50). SN 79-092,484. PUB. 1-10-2012. FILED 12-20-2010.
 4,116,726. **GO APE (STANDARD CHARACTER)**. ADVENTURE FOREST GROUP LIMITED, MULTIPLE CLASS, (INT. CLS. 16, 25, 41 AND 43), (U.S. CLS. 2, 5, 22, 23, 29, 37, 38, 39, 50, 100, 101 AND 107). SN 79-092,606. PUB. 1-10-2012. FILED 3-13-2010.
 4,116,729 (*See Class 9 for this trademark*).
 4,116,730. **MISCELLANEOUS DESIGN**. MARIMEKKO OYJ, MULTIPLE CLASS, (INT. CLS. 16, 18, 21, 24 AND 25), (U.S. CLS. 1, 2, 3, 5, 13, 22, 23, 29, 30, 33, 37, 38, 39, 40, 41, 42 AND 50). SN 79-093,557. PUB. 1-10-2012. FILED 2-4-2011.
 4,116,735 (*See Class 5 for this trademark*).
 4,116,757 (*See Class 9 for this trademark*).
 4,116,763. **ORDER OF THE LILY AND THE EAGLE ORDE DU LYS ET DE L'AIGLE ORDEM DO LÍRIO E DA ÁGUA AND DESIGN**. PHILOSOFHIKIETAIRTA TO TAGMA TOY KRINOU KAI TOU AETOU, MULTIPLE CLASS, (INT. CLS. 16, 41 AND 42), (U.S. CLS. 2, 5, 22, 23, 29, 37, 38, 50, 100, 101 AND 107). SN 79-095,934. PUB. 1-10-2012. FILED 3-8-2011.
 4,116,764 (*See Class 9 for this trademark*).
 4,116,767. **SOLIQ (STANDARD CHARACTER)**. BILLERUD AB, MULTIPLE CLASS, (INT. CLS. 16, 39 AND 42), (U.S. CLS. 2, 5, 22, 23, 29, 37, 38, 50, 100, 101 AND 105). SN 79-096,131. PUB. 1-10-2012. FILED 2-7-2011.
 4,116,770. **SMA SOLAR ACADEMY AND DESIGN**. SMA SOLAR TECHNOLOGY AG, MULTIPLE CLASS, (INT. CLS. 16 AND 41), (U.S. CLS. 2, 5, 22, 23, 29, 37, 38, 50, 100, 101 AND 107). SN 79-096,226. PUB. 1-10-2012. FILED 10-9-2010.
 4,116,775 (*See Class 9 for this trademark*).
 4,116,795. **CELISTIC AND DESIGN**. OBSHESTVO S OGRANICHENNOI OTVETSTVENNOSTYU "CELISTIC", MULTIPLE CLASS, (INT. CLS. 16, 28 AND 41), (U.S. CLS. 2, 5, 22, 23, 29, 37, 38, 50, 100, 101 AND 107). SN 79-097,791. PUB. 1-10-2012. FILED 4-21-2011.
 4,116,796. **TANG (STYLIZED)**. KIM, HYUNG MIN, (U.S. CLS. 2, 5, 22, 23, 29, 37, 38 AND 50). SN 79-097,836. PUB. 1-10-2012. FILED 4-29-2011.
 4,116,808. **TRASMUDA DI RENATA RIGHETTI AND DESIGN**. RENATA RIGHETTI, MULTIPLE CLASS, (INT. CLS. 16, 41 AND 44), (U.S. CLS. 2, 5, 22, 23, 29, 37, 38, 50, 100, 101 AND 107). SN 79-099,008. PUB. 1-10-2012. FILED 12-15-2010.
 4,116,815 (*See Class 9 for this trademark*).
 4,116,820. **E-PHOTO (STANDARD CHARACTER)**. FELIX SCHOELLER JR. FOTO UND SPEZIALPAPIERE GMBH & CO. KG, (U.S. CLS. 2, 5, 22, 23, 29, 37, 38 AND 50). SN 79-099,803. PUB. 1-10-2012. FILED 5-4-2011.
 4,116,856 (*See Class 9 for this trademark*).
 4,116,860. **UNI PROMARK VIEW (STYLIZED)**. MITSUBISHI PENCIL COMPANY, LIMITED, (U.S. CLS. 2, 5, 22, 23, 29, 37, 38 AND 50). SN 79-102,400. PUB. 1-10-2012. FILED 8-11-2011.
 4,116,937 (*See Class 9 for this trademark*).
 4,116,972. **FAIRY GODMOTHER AND DESIGN**. FISKEN, LYNDA MARLO, (U.S. CLS. 2, 5, 22, 23, 29, 37, 38 AND 50). SN 85-157,418. PUB. 1-10-2012. FILED 10-20-2010.
 4,117,022 (*See Class 9 for this trademark*).
 4,117,023 (*See Class 9 for this trademark*).
 4,117,024 (*See Class 9 for this trademark*).
 4,117,065. **ADVENTURES OF HENRY AND DESIGN**. ADVENTURES OF HENRY, LLC, (U.S. CLS. 2, 5, 22, 23, 29, 37, 38 AND 50). SN 85-220,521. PUB. 1-10-2012. FILED 1-18-2011.
 4,117,090 (*See Class 9 for this trademark*).
 4,117,117. **PROFESSOR CHALLENGER (STANDARD CHARACTER)**. CONAN DOYLE ESTATE LIMITED, (U.S. CLS. 2, 5, 22, 23, 29, 37, 38 AND 50). SN 85-229,775. PUB. 1-10-2012. FILED 1-31-2011.
 4,117,120. **ENLACE CENTROAMERICA TU REVISTA MENSUAL SIEMPRE (STYLIZED)**. ENLACE GUATEMALA, INC., (U.S. CLS. 2, 5, 22, 23, 29, 37, 38 AND 50). SN 85-230,283. PUB. 1-10-2012. FILED 1-31-2011.
 4,117,136. **RECOVERY, EMERGENCY, DISASTER; RED; THE RED GUIDE TO RECOVERY; RESOURCE HANDBOOK FOR DISASTER SURVIVORS AND DESIGN**. SEAN SCOTT, (U.S. CLS. 2, 5, 22, 23, 29, 37, 38 AND 50). SN 85-232,547. PUB. 1-10-2012. FILED 2-2-2011.
 4,117,141 (*See Class 9 for this trademark*).
 4,117,147. **SPECTRUM INVESTOR FUND MONITORING SCORECARD (STANDARD CHARACTER)**. MARSHALL, JAMES F., MULTIPLE CLASS, (INT. CLS. 16 AND 36), (U.S. CLS. 2, 5, 22, 23, 29, 37, 38, 50, 100, 101 AND 102). SN 85-233,710. PUB. 1-10-2012. FILED 2-3-2011.
 4,117,151. **CHICKENHARE (STYLIZED)**. GRINE, CHRISTOPHER A., (U.S. CLS. 2, 5, 22, 23, 29, 37, 38 AND 50). SN 85-233,879. PUB. 1-10-2012. FILED 2-3-2011.
 4,117,174 (*See Class 2 for this trademark*).
 4,117,176. **VICTIM OR VOLUNTEER (STANDARD CHARACTER)**. LAURENE A GERSON, (U.S. CLS. 2, 5, 22, 23, 29, 37, 38 AND 50). SN 85-237,025. PUB. 1-10-2012. FILED 2-8-2011.
 4,117,202. **SHOW AND TELL GOLF RULES AND DESIGN**. TROUBETZKOY, SUSAN M., (U.S. CLS. 2, 5, 22, 23, 29, 37, 38 AND 50). SN 85-240,916. PUB. 1-10-2012. FILED 2-12-2011.
 4,117,243. **APLS (STANDARD CHARACTER)**. AMERICAN ACADEMY OF PEDIATRICS, MULTIPLE CLASS, (INT. CLS. 16 AND 41), (U.S. CLS. 2, 5, 22, 23, 29, 37, 38, 50, 100, 101 AND 107). SN 85-247,920. PUB. 1-10-2012. FILED 2-22-2011.
 4,117,244. **PEPP PEDIATRIC EDUCATION FOR PREHOSPITAL PROFESSIONALS AND DESIGN**. AMERICAN ACADEMY OF PEDIATRICS, MULTIPLE CLASS, (INT. CLS. 16 AND 41), (U.S. CLS. 2, 5, 22, 23, 29, 37, 38, 50, 100, 101 AND 107). SN 85-247,921. PUB. 1-10-2012. FILED 2-22-2011.
 4,117,247. **SICURA ITALIAN DESIGNS AND DESIGN**. ARGENTO SC BY SICURA INC., MULTIPLE CLASS, (INT. CLS. 16 AND 20), (U.S. CLS. 2, 5, 13, 22, 23, 25, 29, 32, 37, 38

- AND 50). SN 85-248,509. PUB. 1-10-2012. FILED 2-22-2011.
4,117,272 (*See Class 7 for this trademark*).
- 4,117,277. **GOD'S DESIGN (STANDARD CHARACTER)**. ANSWERS IN GENESIS, INC., (U.S. CLS. 2, 5, 22, 23, 29, 37, 38 AND 50). SN 85-255,650. PUB. 1-10-2012. FILED 3-2-2011.
- 4,117,312. **SOFTBALL MAGAZINE AND DESIGN**. BREVARD SOFTBALL MAGAZINE, INC., (U.S. CLS. 2, 5, 22, 23, 29, 37, 38 AND 50). SN 85-262,526. PUB. 1-10-2012. FILED 3-9-2011.
- 4,117,325. **THE GENERAL ASSEMBLY OF SPIRITUALISTS (STANDARD CHARACTER)**. THE GENERAL ASSEMBLY OF SPIRITUALISTS, (U.S. CLS. 2, 5, 22, 23, 29, 37, 38 AND 50). SN 85-267,026. PUB. 1-10-2012. FILED 3-15-2011.
- 4,117,363 (*See Class 9 for this trademark*).
- 4,117,393. **THE KING LEGACY (STANDARD CHARACTER)**. UNITARIAN UNIVERSALIST ASSOCIATION CORPORATION, DBA BEACON PRESS, (U.S. CLS. 2, 5, 22, 23, 29, 37, 38 AND 50). SN 85-281,427. PUB. 1-10-2012. FILED 3-30-2011.
- 4,117,396. **SANTA CLAUSET (STANDARD CHARACTER)**. SANTA CLAUSET TOYS LC, MULTIPLE CLASS, (INT. CLS. 16 AND 28), (U.S. CLS. 2, 5, 22, 23, 29, 37, 38 AND 50). SN 85-281,638. PUB. 1-10-2012. FILED 3-30-2011.
- 4,117,412. **POLAR BEAR POST AIR MAIL AND DESIGN**. SANTA CLAUSET TOYS LC, MULTIPLE CLASS, (INT. CLS. 16 AND 28), (U.S. CLS. 2, 5, 22, 23, 29, 37, 38 AND 50). SN 85-285,755. PUB. 1-10-2012. FILED 4-4-2011.
- 4,117,413. **SANTA CLAUSET AND DESIGN**. SANTA CLAUSET TOYS LC, MULTIPLE CLASS, (INT. CLS. 16 AND 28), (U.S. CLS. 2, 5, 22, 23, 29, 37, 38 AND 50). SN 85-285,758. PUB. 1-10-2012. FILED 4-4-2011.
- 4,117,422. **TOOL MATES (STANDARD CHARACTER)**. SIMON DOUGLAS THOMAS, (U.S. CLS. 2, 5, 22, 23, 29, 37, 38 AND 50). SN 85-287,472. PUB. 1-10-2012. FILED 4-6-2011.
- 4,117,445. **THE ART OF DELIBERATE SUCCESS (STANDARD CHARACTER)**. THE LEARNING JUNCTION LIMITED, MULTIPLE CLASS, (INT. CLS. 16 AND 41), (U.S. CLS. 2, 5, 22, 23, 29, 37, 38, 50, 100, 101 AND 107). SN 85-292,033. PUB. 1-10-2012. FILED 4-11-2011.
- 4,117,478. **RTJ'S CREATIVE CATECHIST (STANDARD CHARACTER)**. BAYARD, INC., (U.S. CLS. 2, 5, 22, 23, 29, 37, 38 AND 50). SN 85-297,749. PUB. 1-10-2012. FILED 4-18-2011.
- 4,117,496. **TALKIN' THE BAKKEN (STANDARD CHARACTER)**. WICK COMMUNICATIONS CO., MULTIPLE CLASS, (INT. CLS. 16, 35 AND 41), (U.S. CLS. 2, 5, 22, 23, 29, 37, 38, 50, 100, 101, 102 AND 107). SN 85-301,488. PUB. 1-10-2012. FILED 4-21-2011.
- 4,117,527. **ANGEL KIT AND DESIGN**. ANGEL KIT FOUNDATION, INC. (U.S. CLS. 2, 5, 22, 23, 29, 37, 38 AND 50). SN 85-307,869. PUB. 1-10-2012. FILED 4-28-2011.
- 4,117,534. **SMALL HOME BUILDING MADE EASY (STANDARD CHARACTER)**. J. MARPLE PUBLISHING, LLC, (U.S. CLS. 2, 5, 22, 23, 29, 37, 38 AND 50). SN 85-310,279. PUB. 1-10-2012. FILED 5-2-2011.
- 4,117,550. **WALLMONKEYS (STANDARD CHARACTER)**. WALLMONKEYS.COM, (U.S. CLS. 2, 5, 22, 23, 29, 37, 38 AND 50). SN 85-313,756. PUB. 1-10-2012. FILED 5-5-2011.
- 4,117,586. **RACE MATTERS (STANDARD CHARACTER)**. THE ANNIE E. CASEY FOUNDATION, INC., MULTIPLE CLASS, (INT. CLS. 16 AND 45), (U.S. CLS. 2, 5, 22, 23, 29, 37, 38, 50, 100 AND 101). SN 85-322,490. PUB. 1-10-2012. FILED 5-17-2011.
- 4,117,658 (*See Class 9 for this trademark*).
- 4,117,672 (*See Class 9 for this trademark*).
- 4,117,682. **RABID FISH (STANDARD CHARACTER)**. EDDY, MICHAEL S., (U.S. CLS. 2, 5, 22, 23, 29, 37, 38 AND 50). SN 85-339,942. PUB. 1-10-2012. FILED 6-7-2011.
- 4,117,787 (*See Class 9 for this trademark*).
- 4,117,839 (*See Class 5 for this trademark*).
- 4,117,917. **PAINTINGS WITH A HEARTBEAT (STANDARD CHARACTER)**. RAMONA DOOLEY, (U.S. CLS. 2, 5, 22, 23, 29, 37, 38 AND 50). SN 85-368,367. PUB. 1-10-2012. FILED 7-11-2011.
- 4,117,949. **FUTURE SHOP (STANDARD CHARACTER)**. WSL MARKETING, INC., DBA WSL STRATEGIC RETAIL, (U.S. CLS. 2, 5, 22, 23, 29, 37, 38 AND 50). SN 85-369,649. PUB. 1-10-2012. FILED 7-12-2011.
- 4,118,102. **TREEHOUSE TIMES (STANDARD CHARACTER)**. LEARNING STAR PUBLICATIONS, (U.S. CLS. 2, 5, 22, 23, 29, 37, 38 AND 50). SN 85-374,369. PUB. 1-10-2012. FILED 7-18-2011.
- 4,118,105. **MISCELLANEOUS DESIGN**. REGAN, LARA JO, (U.S. CLS. 2, 5, 22, 23, 29, 37, 38 AND 50). SN 85-374,419. PUB. 1-10-2012. FILED 7-18-2011.
- 4,118,132 (*See Class 9 for this trademark*).
- 4,118,133 (*See Class 9 for this trademark*).
- 4,118,134 (*See Class 9 for this trademark*).
- 4,118,146. **CITIZENLINK (STANDARD CHARACTER)**. CITIZENLINK, (U.S. CLS. 2, 5, 22, 23, 29, 37, 38 AND 50). SN 85-375,320. PUB. 1-10-2012. FILED 7-19-2011.
- 4,118,160. **ROCK CANDY PRINTS AND DESIGN**. JONES, ANNIE L, DBA ROCK CANDY MEDIA, (U.S. CLS. 2, 5, 22, 23, 29, 37, 38 AND 50). SN 85-375,479. PUB. 1-10-2012. FILED 7-19-2011.
- 4,118,214. **NIGHTLOCK AND DESIGN**. THE PROCTER & GAMBLE COMPANY, (U.S. CLS. 2, 5, 22, 23, 29, 37, 38 AND 50). SN 85-377,458. PUB. 1-10-2012. FILED 7-21-2011.
- 4,118,224. **MAP DOODLES AND DESIGN**. PARKER, PATRICIA, (U.S. CLS. 2, 5, 22, 23, 29, 37, 38 AND 50). SN 85-377,701. PUB. 1-10-2012. FILED 7-21-2011.
- 4,118,243. **TINY CONFESSIONS (STANDARD CHARACTER)**. ROZZI, CHRISTOPHER, (U.S. CLS. 2, 5, 22, 23, 29, 37, 38 AND 50). SN 85-378,271. PUB. 1-10-2012. FILED 7-22-2011.
- 4,118,292. **M MOJO FUTURETECH AND DESIGN**. PACIFIC VIBRATIONS LLC, (U.S. CLS. 2, 5, 22, 23, 29, 37, 38 AND 50). SN 85-381,025. PUB. 1-10-2012. FILED 7-26-2011.
- 4,118,298. **MAXINE'S MOP (STANDARD CHARACTER)**. LOEW-CORNELL, LLC, (U.S. CLS. 2, 5, 22, 23, 29, 37, 38 AND 50). SN 85-382,090. PUB. 1-10-2012. FILED 7-27-2011.
- 4,118,322. **MINI SKIRTZ (STANDARD CHARACTER)**. FIREPIT FRIENDS,LLC, DBA CONFETTI COUTURE, (U.S. CLS. 2, 5, 22, 23, 29, 37, 38 AND 50). SN 85-387,754. PUB. 1-10-2012. FILED 8-2-2011.
- 4,118,327. **SHIELD N SEAL AND DESIGN**. SAVENSEAL.COM LTD, (U.S. CLS. 2, 5, 22, 23, 29, 37, 38 AND 50). SN 85-388,053. PUB. 1-10-2012. FILED 8-3-2011.
- 4,118,372. **ONAKWEST (STANDARD CHARACTER)**. ONAKWEST, LLC, (U.S. CLS. 2, 5, 22, 23, 29, 37, 38 AND 50). SN 85-390,815. PUB. 1-10-2012. FILED 8-5-2011.
- 4,118,436. **LENTIART (STANDARD CHARACTER)**. LENTIART, LLC., MULTIPLE CLASS, (INT. CLS. 16 AND 41), (U.S. CLS. 2, 5, 22, 23, 29, 37, 38, 50, 100, 101 AND 107). SN 85-393,054. PUB. 1-10-2012. FILED 8-9-2011.
- 4,118,511. **WALCOUTURE (STANDARD CHARACTER)**. GALLERY BLOCKS, LLC, MULTIPLE CLASS, (INT. CLS. 16 AND 40), (U.S. CLS. 2, 5, 22, 23, 29, 37, 38, 50, 100, 103 AND 106). SN 85-394,425. PUB. 1-10-2012. FILED 8-10-2011.
- 4,118,538. **BLUE WEATHER AND DESIGN**. CONVERTIDORA DE PAPEL DEL NOROESTE S.A. DE C.V., (U.S. CLS. 2, 5, 22, 23, 29, 37, 38 AND 50). SN 85-394,997. PUB. 1-10-2012. FILED 8-10-2011.
- 4,118,621. **GOD'S WISDOM (STANDARD CHARACTER)**. THOMAS NELSON, INC., (U.S. CLS. 2, 5, 22, 23, 29, 37, 38 AND 50). SN 85-396,810. PUB. 1-10-2012. FILED 8-12-2011.
- 4,118,624. **WERE-HUNTER (STANDARD CHARACTER)**. KENYON, SHERRILYN, (U.S. CLS. 2, 5, 22, 23, 29, 37, 38 AND 50). SN 85-396,837. PUB. 1-10-2012. FILED 8-12-2011.
- 4,118,625. **THE LEAGUE (STANDARD CHARACTER)**. KENYON, SHERRILYN, (U.S. CLS. 2, 5, 22, 23, 29, 37, 38 AND 50). SN 85-396,851. PUB. 1-10-2012. FILED 8-12-2011.
- 4,118,626. **DREAM-HUNTER (STANDARD CHARACTER)**. KENYON, SHERRILYN, (U.S. CLS. 2, 5, 22, 23, 29, 37, 38 AND 50). SN 85-396,858. PUB. 1-10-2012. FILED 8-12-2011.
- 4,118,627. **CHRONICLES OF NICK (STANDARD CHARACTER)**. KENYON, SHERRILYN, (U.S. CLS. 2, 5, 22, 23, 29, 37, 38 AND 50). SN 85-396,863. PUB. 1-10-2012. FILED 8-12-2011.
- 4,118,712. **REGENESIS (STANDARD CHARACTER)**. MARVEL CHARACTERS, INC., (U.S. CLS. 2, 5, 22, 23, 29, 37, 38 AND 50). SN 85-430,695. PUB. 1-10-2012. FILED 9-23-2011.
- 4,118,718. **REACH & TEACH AND DESIGN**. WKMN NETWORK TRAINING, LLC, DBA REACH AND TEACH, (U.S. CLS. 2, 5, 22, 23, 29, 37, 38 AND 50). SN 85-436,573. PUB. 1-10-2012. FILED 9-30-2011.
- 4,118,746 (*See Class 14 for this trademark*).

CLASS 17—RUBBER GOODS

- 4,116,688 (*See Class 7 for this trademark.*)
- 4,116,737. **NEXTRUSION (STANDARD CHARACTER)**. NEXTRUSION GMBH, MULTIPLE CLASS, (INT. CLS. 17, 23 AND 24), (U.S. CLS. 1, 5, 12, 13, 35, 42, 43 AND 50). SN 79-094,419. PUB. 1-10-2012. FILED 1-18-2011.
- 4,116,779. **REINFORCEKIT (STANDARD CHARACTER)**. SAM 3X ENGINEERING, (U.S. CLS. 1, 5, 12, 13, 35 AND 50). SN 79-096,617. PUB. 1-10-2012. FILED 3-21-2011.
- 4,116,811 (*See Class 6 for this trademark.*)
- 4,116,855. **SUNLOID (STANDARD CHARACTER)**. SUMITOMO BAKELITE CO., LTD., (U.S. CLS. 1, 5, 12, 13, 35 AND 50). SN 79-101,972. PUB. 1-10-2012. FILED 6-1-2011.
- 4,116,894. **ROSATOM AND DESIGN**. STATE ATOMIC ENERGY CORPORATION "ROSATOM", (U.S. CLS. 1, 5, 12, 13, 35 AND 50). SN 85-063,601. PUB. 1-10-2012. FILED 6-15-2010.
- 4,116,925. **MACROCORE (STANDARD CHARACTER)**. ENGINEERED SYNTACTIC SYSTEMS, LLC, (U.S. CLS. 1, 5, 12, 13, 35 AND 50). SN 85-098,189. PUB. 1-10-2012. FILED 8-2-2010.
- 4,117,001. **LIQUID TOOLKIT AND DESIGN**. HERNON MANUFACTURING, INC., (U.S. CLS. 1, 5, 12, 13, 35 AND 50). SN 85-190,404. PUB. 1-10-2012. FILED 12-3-2010.
- 4,117,011. **PREMISEAL (STANDARD CHARACTER)**. PREMIUM SPRAY PRODUCTS, INC., (U.S. CLS. 1, 5, 12, 13, 35 AND 50). SN 85-194,722. PUB. 1-10-2012. FILED 12-9-2010.
- 4,117,081. **TRAZCON (STANDARD CHARACTER)**. FLOORTECH INTERNATIONAL LIMITED, MULTIPLE CLASS, (INT. CLS. 17, 19 AND 37), (U.S. CLS. 1, 5, 12, 13, 33, 35, 50, 100, 103 AND 106). SN 85-222,816. PUB. 1-10-2012. FILED 1-21-2011.
- 4,117,411. **ORANGE AND DESIGN**. ORANGE PRODUCTS, INC., MULTIPLE CLASS, (INT. CLS. 17 AND 28), (U.S. CLS. 1, 5, 12, 13, 22, 23, 35, 38 AND 50). SN 85-285,183. PUB. 1-10-2012. FILED 4-4-2011.
- 4,117,443. **BLOCK-TITE (STANDARD CHARACTER)**. CURWOOD, INC., (U.S. CLS. 1, 5, 12, 13, 35 AND 50). SN 85-291,927. PUB. 1-10-2012. FILED 4-11-2011.
- 4,117,574. **MEGATAPE (STANDARD CHARACTER)**. E. L. HATTON SALES CO., (U.S. CLS. 1, 5, 12, 13, 35 AND 50). SN 85-320,231. PUB. 1-10-2012. FILED 5-13-2011.
- 4,117,673. **FLUOROCEM (STANDARD CHARACTER)**. MARTIN FLUID POWER COMPANY, (U.S. CLS. 1, 5, 12, 13, 35 AND 50). SN 85-338,442. PUB. 1-10-2012. FILED 6-6-2011.
- 4,117,880 (*See Class 2 for this trademark.*)
- 4,118,315. **RAIN GUARD (STANDARD CHARACTER)**. HENKEL CORPORATION, (U.S. CLS. 1, 5, 12, 13, 35 AND 50). SN 85-386,865. PUB. 1-10-2012. FILED 8-2-2011.
- 4,118,475. **PROJECT 1 (STANDARD CHARACTER)**. MECHANICS HELPER, INC., DBA HI-TEC INDUSTRIES, (U.S. CLS. 1, 5, 12, 13, 35 AND 50). SN 85-393,604. PUB. 1-10-2012. FILED 8-9-2011.
- 4,116,706 (*See Class 3 for this trademark.*)
- 4,116,707 (*See Class 8 for this trademark.*)
- 4,116,711. **JANPO (STANDARD CHARACTER)**. X-TECHNOLOGY SWISS GMBH, MULTIPLE CLASS, (INT. CLS. 18, 25 AND 28), (U.S. CLS. 1, 2, 3, 22, 23, 38, 39, 41 AND 50). SN 79-088,091. PUB. 1-10-2012. FILED 7-13-2010.
- 4,116,723. **MONELLA VAGABONDA AND DESIGN**. GIELLE S.R.L., MULTIPLE CLASS, (INT. CLS. 18 AND 25), (U.S. CLS. 1, 2, 3, 22, 39 AND 41). SN 79-091,539. PUB. 1-10-2012. FILED 10-7-2010.
- 4,116,725 (*See Class 16 for this trademark.*)
- 4,116,730 (*See Class 16 for this trademark.*)
- 4,116,740. **PONCHO COMPANY AND DESIGN**. PACIFIC HOME GMBH, MULTIPLE CLASS, (INT. CLS. 18 AND 25), (U.S. CLS. 1, 2, 3, 22, 39 AND 41). SN 79-094,847. PUB. 1-10-2012. FILED 2-8-2011.
- 4,116,757 (*See Class 9 for this trademark.*)
- 4,116,759 (*See Class 9 for this trademark.*)
- 4,116,768 (*See Class 3 for this trademark.*)
- 4,116,772. **DESIGN FOR EASY LIVING (STANDARD CHARACTER)**. MAX MARA INTERNATIONAL S.A., MULTIPLE CLASS, (INT. CLS. 18 AND 25), (U.S. CLS. 1, 2, 3, 22, 39 AND 41). SN 79-096,270. PUB. 1-10-2012. FILED 2-15-2011.
- 4,116,792. **MONCABAS (STYLIZED)**. CARIMAX CORPORATION, (U.S. CLS. 1, 2, 3, 22 AND 41). SN 79-097,655. PUB. 1-10-2012. FILED 4-25-2011.
- 4,116,826 (*See Class 6 for this trademark.*)
- 4,116,854. **ZERO AIR (STANDARD CHARACTER)**. ACE CO., LTD., (U.S. CLS. 1, 2, 3, 22 AND 41). SN 79-101,877. PUB. 1-10-2012. FILED 6-14-2011.
- 4,116,926 (*See Class 9 for this trademark.*)
- 4,116,927 (*See Class 9 for this trademark.*)
- 4,117,172. **LYF LOVE YOU FOREVER (STYLIZED)**. LYF PRODUCTIONS LLC, (U.S. CLS. 1, 2, 3, 22 AND 41). SN 85-236,317. PUB. 1-10-2012. FILED 2-8-2011.
- 4,117,367. **FROU-FROU (STANDARD CHARACTER)**. THE TIX COMPANIES, INC., MULTIPLE CLASS, (INT. CLS. 18 AND 20), (U.S. CLS. 1, 2, 3, 13, 22, 25, 32, 41 AND 50). SN 85-275,321. PUB. 1-10-2012. FILED 3-24-2011.
- 4,117,374. **ISLAND BEACH AND DESIGN**. DSC SALES, INC., MULTIPLE CLASS, (INT. CLS. 18, 24 AND 25), (U.S. CLS. 1, 2, 3, 22, 39, 41, 42 AND 50). SN 85-278,409. PUB. 8-9-2011. FILED 3-28-2011.
- 4,117,458. **MISCELLANEOUS DESIGN**. JANUS ET CIE, (U.S. CLS. 1, 2, 3, 22 AND 41). SN 85-294,350. PUB. 1-10-2012. FILED 4-13-2011.
- 4,117,706. **BAABAAZUZU AND DESIGN**. BAA BAA ZUZU, INC., MULTIPLE CLASS, (INT. CLS. 18, 25 AND 26), (U.S. CLS. 1, 2, 3, 22, 37, 39, 40, 41, 42 AND 50). SN 85-344,720. PUB. 1-10-2012. FILED 6-13-2011.
- 4,117,736. **FLANABAGS AND DESIGN**. FLANAGAN, LINDA M., DBA FLANABAGS, (U.S. CLS. 1, 2, 3, 22 AND 41). SN 85-349,847. PUB. 1-10-2012. FILED 6-18-2011.
- 4,117,742 (*See Class 3 for this trademark.*)
- 4,117,809. **NORTH WIND AND DESIGN**. DOVER SADDLERY, INC., (U.S. CLS. 1, 2, 3, 22 AND 41). SN 85-359,066. PUB. 1-10-2012. FILED 6-29-2011.
- 4,117,834 (*See Class 9 for this trademark.*)
- 4,118,144. **MOOSE PET WEAR (STANDARD CHARACTER)**. STRAPWORKS LLC, DBA MOOSE PET WEAR, (U.S. CLS. 1, 2, 3, 22 AND 41). SN 85-375,302. PUB. 1-10-2012. FILED 7-19-2011.
- 4,118,221. **MYBAG (STANDARD CHARACTER)**. DA DIRECT INC., MULTIPLE CLASS, (INT. CLS. 18 AND 35), (U.S. CLS. 1, 2, 3, 22, 41, 100, 101 AND 102). SN 85-377,613. PUB. 1-10-2012. FILED 7-21-2011.
- 4,118,271 (*See Class 14 for this trademark.*)
- 4,118,355 (*See Class 9 for this trademark.*)
- 4,118,458. **CHICMIO AND DESIGN**. VYAN, LLC, MULTIPLE CLASS, (INT. CLS. 18, 25 AND 35), (U.S. CLS. 1, 2, 3, 22, 39, 41, 100, 101 AND 102). SN 85-393,338. PUB. 1-10-2012. FILED 8-9-2011.
- 4,118,508. **MISCELLANEOUS DESIGN**. NBA PROPERTIES, INC., (U.S. CLS. 1, 2, 3, 22 AND 41). SN 85-394,367. PUB. 1-10-2012. FILED 8-10-2011.
- 4,118,537. **SSCY (STANDARD CHARACTER)**. SELDON YUAN, (U.S. CLS. 1, 2, 3, 22 AND 41). SN 85-394,993. PUB. 1-10-2012. FILED 8-10-2011.

CLASS 18—LEATHER GOODS

- 4,116,602 (*See Class 9 for this trademark.*)
- 4,116,666. **GGL (STANDARD CHARACTER)**. UNION HARBOUR LIMITED, MULTIPLE CLASS, (INT. CLS. 18 AND 25), (U.S. CLS. 1, 2, 3, 22, 39 AND 41). SN 77-982,496. PUB. 8-26-2008. FILED 8-17-2007.
- 4,116,667. **GG&L (STANDARD CHARACTER)**. UNION HARBOUR LIMITED, MULTIPLE CLASS, (INT. CLS. 18 AND 25), (U.S. CLS. 1, 2, 3, 22, 39 AND 41). SN 77-982,728. PUB. 1-10-2012. FILED 8-17-2007.
- 4,116,680. **INDIVIDUAL AND DESIGN**. INDIVIDUAL CONCEPT SA, MULTIPLE CLASS, (INT. CLS. 18 AND 24), (U.S. CLS. 1, 2, 3, 22, 41, 42 AND 50). SN 79-077,374. PUB. 1-10-2012. FILED 11-4-2009.
- 4,116,698. **GOLF AND DESIGN**. THE GOLF FASHION COMPANY, INHABER PRODRAMOS TSARNOS, MULTIPLE CLASS, (INT. CLS. 18 AND 25), (U.S. CLS. 1, 2, 3, 22, 39 AND 41). SN 79-085,938. PUB. 1-10-2012. FILED 7-29-2010.
- 4,116,703 (*See Class 8 for this trademark.*)

4,118,634. **SACKFULLA (STANDARD CHARACTER)**. KAREN R LANE, DBA SACKFULLA. (U.S. CLS. 1, 2, 3, 22 AND 41). SN 85-396,951. PUB. 1-10-2012. FILED 8-12-2011.

CLASS 19—NON-METALLIC BUILDING MATERIALS

4,116,594. **B AND DESIGN**. BALLYMORE PROPERTIES LIMITED, MULTIPLE CLASS, (INT. CLS. 19, 36, 37 AND 42), (U.S. CLS. 1, 12, 33, 50, 100, 101, 102, 103 AND 106). SN 77-293,086. PUB. 1-10-2012. FILED 10-1-2007.

4,116,599. **ECOSSENTIAL (STANDARD CHARACTER)**. QUALITY CRAFT LTD., MULTIPLE CLASS, (INT. CLS. 19 AND 20), (U.S. CLS. 1, 2, 12, 13, 22, 25, 32, 33 AND 50). SN 77-403,007. PUB. 1-10-2012. FILED 2-21-2008.

4,116,640. **VERSADOCK AND DESIGN**. AHERN, ROY, (U.S. CLS. 1, 12, 33 AND 50). SN 77-870,805. PUB. 1-10-2012. FILED 11-12-2009.

4,116,643. **BUTTSKOOT (STANDARD CHARACTER)**. WILLOW RIVER SALES LLC, (U.S. CLS. 1, 12, 33 AND 50). SN 77-873,028. PUB. 1-10-2012. FILED 11-16-2009.

4,116,678 (*See Class 1 for this trademark*).

4,116,704 (*See Class 1 for this trademark*).

4,116,727 (*See Class 7 for this trademark*).

4,116,811 (*See Class 6 for this trademark*).

4,116,874. **RINGTRAC (STANDARD CHARACTER)**. HUESKER SYNTHETIC GMBH, (U.S. CLS. 1, 12, 33 AND 50). SN 79-105,060. PUB. 1-10-2012. FILED 8-9-2011.

4,116,950. **NU GREEN 2 (STANDARD CHARACTER)**. UNIBOARD CANADA INC., MULTIPLE CLASS, (INT. CLS. 19 AND 20), (U.S. CLS. 1, 2, 12, 13, 22, 25, 32, 33 AND 50). SN 85-131,567. PUB. 1-10-2012. FILED 9-16-2010.

4,117,081 (*See Class 17 for this trademark*).

4,117,155. **ZICANA (STANDARD CHARACTER)**. ZICANA, LLC, (U.S. CLS. 1, 12, 33 AND 50). SN 85-234,448. PUB. 1-10-2012. FILED 2-4-2011.

4,117,206. **BILDRITE (STANDARD CHARACTER)**. INTERNATIONAL BILDRITE, INC., (U.S. CLS. 1, 12, 33 AND 50). SN 85-241,516. PUB. 1-10-2012. FILED 2-14-2011.

4,117,208. **ROOFRITE (STANDARD CHARACTER)**. INTERNATIONAL BILDRITE, INC., (U.S. CLS. 1, 12, 33 AND 50). SN 85-241,590. PUB. 1-10-2012. FILED 2-14-2011.

4,117,209. **BRACERITE (STANDARD CHARACTER)**. INTERNATIONAL BILDRITE, INC., (U.S. CLS. 1, 12, 33 AND 50). SN 85-241,629. PUB. 1-10-2012. FILED 2-14-2011.

4,117,210. **GRAYLITE (STANDARD CHARACTER)**. INTERNATIONAL BILDRITE, INC., (U.S. CLS. 1, 12, 33 AND 50). SN 85-241,674. PUB. 1-10-2012. FILED 2-14-2011.

4,117,211. **FOUNDRITE (STANDARD CHARACTER)**. INTERNATIONAL BILDRITE, INC., (U.S. CLS. 1, 12, 33 AND 50). SN 85-241,719. PUB. 1-10-2012. FILED 2-14-2011.

4,117,218. **ICE MATTERS (STANDARD CHARACTER)**. ICE MATTERS, LLC, MULTIPLE CLASS, (INT. CLS. 19 AND 41), (U.S. CLS. 1, 12, 33, 50, 100, 101 AND 107). SN 85-243,292. PUB. 1-10-2012. FILED 2-15-2011.

4,117,222. **FRAMEWORKS (STANDARD CHARACTER)**. ASSOCIATED MATERIALS, LLC, (U.S. CLS. 1, 12, 33 AND 50). SN 85-245,122. PUB. 1-10-2012. FILED 2-17-2011.

4,117,237. **FIRESIST (STANDARD CHARACTER)**. KCH SERVICES, INC., DBA KCH ENGINEERED SYSTEMS, (U.S. CLS. 1, 12, 33 AND 50). SN 85-247,414. PUB. 1-10-2012. FILED 2-21-2011.

4,117,299 (*See Class 11 for this trademark*).

4,117,811. **SABER (STANDARD CHARACTER)**. SABER INDUSTRIES INC., (U.S. CLS. 1, 12, 33 AND 50). SN 85-359,258. PUB. 1-10-2012. FILED 6-29-2011.

4,117,842. **KOLORITUFF BY IGA (STYLIZED)**. INSULATED GLASS OF AMERICA, INC, (U.S. CLS. 1, 12, 33 AND 50). SN 85-363,290. PUB. 1-10-2012. FILED 7-5-2011.

4,117,968. **CALSTONE (STANDARD CHARACTER)**. CALSTONE COMPANY, (U.S. CLS. 1, 12, 33 AND 50). SN 85-370,679. PUB. 1-10-2012. FILED 7-13-2011.

4,118,082. **HOME BASICS CHILD SAFE & ENVIRONMENTALLY RESPONSIBLE PRODUCTS FOR YOUR HOME AND DESIGN**. WHOLE SPACE INDUSTRIES LTD., (U.S. CLS. 1, 12, 33 AND 50). SN 85-374,041. PUB. 1-10-2012.

FILED 7-18-2011.

4,118,323. **GUTTERSTUFF (STANDARD CHARACTER)**. JONES, ROBERT W., (U.S. CLS. 1, 12, 33 AND 50). SN 85-387,849. PUB. 1-10-2012. FILED 8-3-2011.

4,118,337. **NYDREE FLOORING (STYLIZED)**. NYDREE FLOORING LLC, (U.S. CLS. 1, 12, 33 AND 50). SN 85-388,559. PUB. 1-10-2012. FILED 8-3-2011.

4,118,745 (*See Class 4 for this trademark*).

CLASS 20—FURNITURE AND ARTICLES NOT OTHERWISE CLASSIFIED

4,116,570. **POSTUREWELL (STANDARD CHARACTER)**. BRYER, MATTHEW D., DBA POSTUREWELL, (U.S. CLS. 2, 13, 22, 25, 32 AND 50). SN 76-706,879. PUB. 1-10-2012. FILED 3-17-2011.

4,116,599 (*See Class 19 for this trademark*).

4,116,602 (*See Class 9 for this trademark*).

4,116,641. **ZEDBED (STANDARD CHARACTER)**. CORPORATION ZEDBED INTERNATIONAL INC., (U.S. CLS. 2, 13, 22, 25, 32 AND 50). SN 77-871,341. PUB. 1-10-2012. FILED 11-12-2009.

4,116,642. **ZEDBED AND DESIGN**. CORPORATION ZEDBED INTERNATIONAL INC., (U.S. CLS. 2, 13, 22, 25, 32 AND 50). SN 77-871,359. PUB. 1-10-2012. FILED 11-12-2009.

4,116,683 (*See Class 6 for this trademark*).

4,116,703 (*See Class 8 for this trademark*).

4,116,707 (*See Class 8 for this trademark*).

4,116,757 (*See Class 9 for this trademark*).

4,116,812 (*See Class 6 for this trademark*).

4,116,825. **MOJO (STANDARD CHARACTER)**. EUROTRADE (W) LIMITED, MULTIPLE CLASS, (INT. CLS. 20, 21 AND 28), (U.S. CLS. 2, 13, 22, 23, 25, 29, 30, 32, 33, 38, 40 AND 50). SN 79-100,169. PUB. 1-10-2012. FILED 3-15-2011.

4,116,908. **MALIBU (STANDARD CHARACTER)**. J. BAXTER BRINKMANN INTERNATIONAL CORPORATION, (U.S. CLS. 2, 13, 22, 25, 32 AND 50). SN 85-077,494. PUB. 1-10-2012. FILED 7-2-2010.

4,116,950 (*See Class 19 for this trademark*).

4,117,003. **COLEMAN (STANDARD CHARACTER)**. THE COLEMAN COMPANY, INC., (U.S. CLS. 2, 13, 22, 25, 32 AND 50). SN 85-192,319. PUB. 1-10-2012. FILED 12-7-2010.

4,117,004. **COLEMAN AND DESIGN**. THE COLEMAN COMPANY, INC., (U.S. CLS. 2, 13, 22, 25, 32 AND 50). SN 85-192,422. PUB. 1-10-2012. FILED 12-7-2010.

4,117,005. **MISCELLANEOUS DESIGN**. THE COLEMAN COMPANY, INC., (U.S. CLS. 2, 13, 22, 25, 32 AND 50). SN 85-192,565. PUB. 1-10-2012. FILED 12-7-2010.

4,117,047. **CAHOOTS (STANDARD CHARACTER)**. KEILHAUER, (U.S. CLS. 2, 13, 22, 25, 32 AND 50). SN 85-214,309. PUB. 1-10-2012. FILED 1-10-2011.

4,117,109. **NO-COMPROMISE (STANDARD CHARACTER)**. BJ2, LLC, MULTIPLE CLASS, (INT. CLS. 20 AND 24), (U.S. CLS. 2, 13, 22, 25, 32, 42 AND 50). SN 85-228,001. PUB. 1-10-2012. FILED 1-27-2011.

4,117,212. **D.O.E. DOWN ON EARTH (STANDARD CHARACTER)**. DOWN ETC, (U.S. CLS. 2, 13, 22, 25, 32 AND 50). SN 85-241,938. PUB. 1-10-2012. FILED 2-14-2011.

4,117,247 (*See Class 16 for this trademark*).

4,117,295. **SMARTSILK (STANDARD CHARACTER)**. SMARTSILK CORPORATION INC., MULTIPLE CLASS, (INT. CLS. 20 AND 24), (U.S. CLS. 2, 13, 22, 25, 32, 42 AND 50). SN 85-259,896. PUB. 1-10-2012. FILED 3-7-2011.

4,117,367 (*See Class 18 for this trademark*).

4,117,446. **TANK-TITE (STANDARD CHARACTER)**. HAYWARD INDUSTRIES, INC., (U.S. CLS. 2, 13, 22, 25, 32 AND 50). SN 85-292,521. PUB. 1-10-2012. FILED 4-12-2011.

4,117,460. **MISCELLANEOUS DESIGN**. JANUS ET CIE, (U.S. CLS. 2, 13, 22, 25, 32 AND 50). SN 85-294,545. PUB. 1-10-2012. FILED 4-13-2011.

4,117,555. **MISSION: ALLERGY AND DESIGN**. MISSION: ALLERGY, INC., MULTIPLE CLASS, (INT. CLS. 20, 24 AND 35), (U.S. CLS. 2, 13, 22, 25, 32, 42, 50, 100, 101 AND 102). SN 85-314,474. PUB. 1-10-2012. FILED 5-6-2011.

4,117,735. **CLOSET BABY AND DESIGN**. CLOSET BABY, LLC, (U.S. CLS. 2, 13, 22, 25, 32 AND 50). SN 85-349,835.

- PUB. 1-10-2012. FILED 6-18-2011.
- 4,117,767. **DIZZ DESIGN AND DESIGN. DIAZ SUNPROTECTION NV, AND DM CROSS ASSOCIATES, LLC, MULTIPLE CLASS, (INT. CLS. 20 AND 24), (U.S. CLS. 2, 13, 22, 25, 32, 42 AND 50).** SN 85-353,815. PUB. 1-10-2012. FILED 6-23-2011.
- 4,117,882 (*See Class 6 for this trademark*).
- 4,117,921. **THE MINICAVA (STANDARD CHARACTER). LUIS LOPEZ, (U.S. CLS. 2, 13, 22, 25, 32 AND 50).** SN 85-368,513. PUB. 1-10-2012. FILED 7-11-2011.
- 4,118,185. **KIDDO TAGS (STANDARD CHARACTER). WEB-GOPHERS, INC., (U.S. CLS. 2, 13, 22, 25, 32 AND 50).** SN 85-376,168. PUB. 1-10-2012. FILED 7-20-2011.
- 4,118,294 (*See Class 3 for this trademark*).
- 4,118,301. **SAAC (STANDARD CHARACTER). CARROLL HALL SHELBY TRUST, MULTIPLE CLASS, (INT. CLS. 20, 21 AND 28), (U.S. CLS. 2, 13, 22, 23, 25, 29, 30, 32, 33, 38, 40 AND 50).** SN 85-382,630. PUB. 1-10-2012. FILED 7-27-2011.
- 4,118,329. **DR. KAY'S (STANDARD CHARACTER). USA ENTERPRISE, (U.S. CLS. 2, 13, 22, 25, 32 AND 50).** SN 85-388,075. PUB. 1-10-2012. FILED 8-3-2011.
- 4,118,375. **TOWELDOG (STANDARD CHARACTER). MARKWARDT, TERRY, L. (U.S. CLS. 2, 13, 22, 25, 32 AND 50).** SN 85-390,877. PUB. 1-10-2012. FILED 8-5-2011.
- 4,118,432. **BARMOIRE (STANDARD CHARACTER). BOYCE, CRAIG, DBA BAR BAZAAR. (U.S. CLS. 2, 13, 22, 25, 32 AND 50).** SN 85-392,985. PUB. 1-10-2012. FILED 8-9-2011.
- 4,118,499. **IMMACULATE COLLECTION (STANDARD CHARACTER). FRANCO HARRIS, (U.S. CLS. 2, 13, 22, 25, 32 AND 50).** SN 85-394,132. PUB. 1-10-2012. FILED 8-10-2011.
- 4,118,555. **BLANKETBOOSTER (STANDARD CHARACTER). BLANKETBOOSTER, INC., (U.S. CLS. 2, 13, 22, 25, 32 AND 50).** SN 85-395,353. PUB. 1-10-2012. FILED 8-11-2011.
- 4,118,558. **SOLE-O (STANDARD CHARACTER). BLANKETBOOSTER, INC., (U.S. CLS. 2, 13, 22, 25, 32 AND 50).** SN 85-395,382. PUB. 1-10-2012. FILED 8-11-2011.
- 4,118,565. **MISCELLANEOUS DESIGN. BLANKETBOOSTER, INC., (U.S. CLS. 2, 13, 22, 25, 32 AND 50).** SN 85-395,504. PUB. 1-10-2012. FILED 8-11-2011.
- 4,118,740. **MANOR HILL (STANDARD CHARACTER). REV-MAN INTERNATIONAL, INC., (U.S. CLS. 2, 13, 22, 25, 32 AND 50).** SN 85-467,942. PUB. 1-10-2012. FILED 11-9-2011.

CLASS 21—HOUSEWARES AND GLASS

- 4,116,566 (*See Class 3 for this trademark*).
- 4,116,602 (*See Class 9 for this trademark*).
- 4,116,703 (*See Class 8 for this trademark*).
- 4,116,725 (*See Class 16 for this trademark*).
- 4,116,730 (*See Class 16 for this trademark*).
- 4,116,757 (*See Class 9 for this trademark*).
- 4,116,825 (*See Class 20 for this trademark*).
- 4,117,142. **FRESH BREATH GETS BOOTY ! (STANDARD CHARACTER). OOIBIT INC., (U.S. CLS. 2, 13, 23, 29, 30, 33, 40 AND 50).** SN 85-233,431. PUB. 1-10-2012. FILED 2-3-2011.
- 4,117,182. **SWEET DANI B (STANDARD CHARACTER). SWEET DANI B, LLC, (U.S. CLS. 2, 13, 23, 29, 30, 33, 40 AND 50).** SN 85-238,176. PUB. 1-10-2012. FILED 2-9-2011.
- 4,117,343. **REDIROOT (STANDARD CHARACTER). NURSERYSOURCE, MULTIPLE CLASS, (INT. CLS. 21 AND 22), (U.S. CLS. 1, 2, 7, 13, 19, 22, 23, 29, 30, 33, 40, 42 AND 50).** SN 85-269,785. PUB. 1-10-2012. FILED 3-17-2011.
- 4,117,361. **TASTINGCRADLE (STANDARD CHARACTER). FUSIONBRANDS INC, (U.S. CLS. 2, 13, 23, 29, 30, 33, 40 AND 50).** SN 85-274,203. PUB. 1-10-2012. FILED 3-23-2011.
- 4,117,375. **LA SERA (STANDARD CHARACTER). THE TJX COMPANIES, INC., (U.S. CLS. 2, 13, 23, 29, 30, 33, 40 AND 50).** SN 85-278,440. PUB. 1-10-2012. FILED 3-28-2011.
- 4,117,497. **PEEPS (STANDARD CHARACTER). BRAINSTORMPRODUCTS, LLC., (U.S. CLS. 2, 13, 23, 29, 30, 33, 40 AND 50).** SN 85-301,701. PUB. 8-16-2011. FILED 4-21-2011.
- 4,117,598. **PATRIOT (STANDARD CHARACTER). THE O'DELL CORPORATION, (U.S. CLS. 2, 13, 23, 29, 30, 33, 40 AND 50).** SN 85-324,139. PUB. 1-10-2012. FILED 5-18-2011.
- 4,117,684. **PANPALS (STANDARD CHARACTER). FOODHANDLER, INC., (U.S. CLS. 2, 13, 23, 29, 30, 33, 40 AND**

- 50). SN 85-340,508. PUB. 1-10-2012. FILED 6-7-2011.
- 4,117,756. **DRINKIN' DUCK (STANDARD CHARACTER). TAI, CHIH-CHENG, AKA DR. JOE TAI, (U.S. CLS. 2, 13, 23, 29, 30, 33, 40 AND 50).** SN 85-352,295. PUB. 1-10-2012. FILED 6-21-2011.
- 4,118,123. **LAST DROP SYSTEM AND DESIGN. THE OUTDOOR RECREATION GROUP. (U.S. CLS. 2, 13, 23, 29, 30, 33, 40 AND 50).** SN 85-374,868. PUB. 1-10-2012. FILED 7-19-2011.
- 4,118,172. **FISH IN THE GARDEN AND DESIGN. FISH IN THE GARDEN, LLC, MULTIPLE CLASS, (INT. CLS. 21 AND 35), (U.S. CLS. 2, 13, 23, 29, 30, 33, 40, 50, 100, 101 AND 102).** SN 85-375,727. PUB. 1-10-2012. FILED 7-20-2011.
- 4,118,277. **BRAWNY INDUSTRIAL (STANDARD CHARACTER). GEORGIA-PACIFIC CONSUMER PRODUCTS LP, (U.S. CLS. 2, 13, 23, 29, 30, 33, 40 AND 50).** SN 85-380,244. PUB. 1-10-2012. FILED 7-25-2011.
- 4,118,301 (*See Class 20 for this trademark*).
- 4,118,342. **MAKING THE WORLD A BETTER PLACE ONE PENNY AT A TIME (STANDARD CHARACTER). MISSY ENTERPRISES, INC., (U.S. CLS. 2, 13, 23, 29, 30, 33, 40 AND 50).** SN 85-389,115. PUB. 1-10-2012. FILED 8-4-2011.
- 4,118,650. **LEDEK (STANDARD CHARACTER). SLY BORD CO., (U.S. CLS. 2, 13, 23, 29, 30, 33, 40 AND 50).** SN 85-397,163. PUB. 1-10-2012. FILED 8-12-2011.
- 4,118,713. **GRIPTEC STRIKER (STANDARD CHARACTER). IRONCLAD PERFORMANCE WEAR CORP., (U.S. CLS. 2, 13, 23, 29, 30, 33, 40 AND 50).** SN 85-431,750. PUB. 1-10-2012. FILED 9-26-2011.
- 4,118,723. **FINGERFLEX TECHNOLOGY AND DESIGN. SUMMIT GLOVE INC., (U.S. CLS. 2, 13, 23, 29, 30, 33, 40 AND 50).** SN 85-443,381. PUB. 1-10-2012. FILED 10-10-2011.

CLASS 22—CORDAGE AND FIBERS

- 4,116,703 (*See Class 8 for this trademark*).
- 4,117,020. **STRAP TRAP (STANDARD CHARACTER). MASTER LOCK COMPANY LLC, (U.S. CLS. 1, 2, 7, 19, 22, 42 AND 50).** SN 85-199,913. PUB. 1-10-2012. FILED 12-16-2010.
- 4,117,343 (*See Class 21 for this trademark*).
- 4,117,410. **OG SACK (STYLIZED). OG SACK, LLC, (U.S. CLS. 1, 2, 7, 19, 22, 42 AND 50).** SN 85-284,528. PUB. 1-10-2012. FILED 4-2-2011.
- 4,117,461. **MISCELLANEOUS DESIGN. JANUS ET CIE, (U.S. CLS. 1, 2, 7, 19, 22, 42 AND 50).** SN 85-294,585. PUB. 1-10-2012. FILED 4-13-2011.

CLASS 23—YARNS AND THREADS

- 4,116,709. **100% BELGIAN LINEN AND DESIGN. PROMOTIECENTRUM VOOR HET VLAS - VERENIGING ZONDER WINSTOOGMERK WINSTOOGMERK, MULTIPLE CLASS, (INT. CLS. 23 AND 24), (U.S. CLS. 42, 43 AND 50).** SN 79-087,818. PUB. 1-10-2012. FILED 6-8-2010.
- 4,116,737 (*See Class 17 for this trademark*).
- 4,117,827. **FILSPUN (STANDARD CHARACTER). DILLON YARN CORPORATION, (U.S. CL. 43).** SN 85-360,983. PUB. 1-10-2012. FILED 6-30-2011.

CLASS 24—FABRICS

- 4,116,680 (*See Class 18 for this trademark*).
- 4,116,709 (*See Class 23 for this trademark*).
- 4,116,716 (*See Class 10 for this trademark*).
- 4,116,725 (*See Class 16 for this trademark*).
- 4,116,730 (*See Class 16 for this trademark*).
- 4,116,737 (*See Class 17 for this trademark*).
- 4,116,757 (*See Class 9 for this trademark*).
- 4,116,848. **MISCELLANEOUS DESIGN. XU LEI, (U.S. CLS. 42 AND 50).** SN 79-101,229. PUB. 1-10-2012. FILED 4-21-2011.
- 4,116,892. **PURITY - LUXURY - COMFORT (STANDARD**

CHARACTER). ABDULLAeva INTERNATIONAL TRADE COMPANY, DBA SLEEP & BEYOND, (U.S. CLS. 42 AND 50). SN 85-051,064. PUB. 1-10-2012. FILED 5-31-2010.

4,117,109 (*See Class 20 for this trademark.*).

4,117,295 (*See Class 20 for this trademark.*).

4,117,374 (*See Class 18 for this trademark.*).

4,117,555 (*See Class 20 for this trademark.*).

4,117,767 (*See Class 20 for this trademark.*).

4,118,051. **GET GOLF READY IN 5 DAYS AND DESIGN.** WORLD GOLF FOUNDATION, INC., MULTIPLE CLASS, (INT. CLS. 24, 36 AND 41), (U.S. CLS. 42, 50, 100, 101, 102 AND 107). SN 85-373,429. PUB. 1-10-2012. FILED 7-18-2011.

4,118,294 (*See Class 3 for this trademark.*).

4,118,698. **MEAN GREEN (STANDARD CHARACTER).** UNIVERSITY OF NORTH TEXAS, (U.S. CLS. 42 AND 50). SN 85-422,251. PUB. 1-10-2012. FILED 9-14-2011.

4,118,741. **MANOR HILL (STANDARD CHARACTER).** REV-MAN INTRNATIONAL, INC., (U.S. CLS. 42 AND 50). SN 85-467,977. PUB. 1-10-2012. FILED 11-9-2011.

CLASS 25—CLOTHING

4,116,551. **KAPALUA.** KAPALUA LAND COMPANY, LTD., (U.S. CLS. 22 AND 39). SN 76-281,773. PUB. 1-10-2012. FILED 7-6-2001.

4,116,569 (*See Class 16 for this trademark.*).

4,116,593 (*See Class 9 for this trademark.*).

4,116,602 (*See Class 9 for this trademark.*).

4,116,609. **SEASUNS (STANDARD CHARACTER).** SEASUNS, (U.S. CLS. 22 AND 39). SN 77-682,403. PUB. 1-10-2012. FILED 3-3-2009.

4,116,629. **THAT'S WHAT SHE SAID (STANDARD CHARACTER).** JOSEPH J. IANELLI 3RD, (U.S. CLS. 22 AND 39). SN 77-803,421. PUB. 1-10-2012. FILED 8-12-2009.

4,116,637. **LOCK IN THOSE LYRICS (STANDARD CHARACTER).** APPLOFF ENTERTAINMENT, INC., (U.S. CLS. 22 AND 39). SN 77-847,131. PUB. 1-10-2012. FILED 10-12-2009.

4,116,660. **CREMIEUX 38 AND DESIGN.** CREMIEUX, STÉPHANE, (U.S. CLS. 22 AND 39). SN 77-932,295. PUB. 1-10-2012. FILED 2-10-2010.

4,116,666 (*See Class 18 for this trademark.*).

4,116,667 (*See Class 18 for this trademark.*).

4,116,668. **NOBLE BUTTERFLY.** NOBLE BUTTERFLY, (U.S. CLS. 22 AND 39). SN 78-181,582. PUB. 1-10-2012. FILED 11-4-2002.

4,116,669 (*See Class 16 for this trademark.*).

4,116,681 (*See Class 9 for this trademark.*).

4,116,684. **RESPIRA (STANDARD CHARACTER).** GEOX SPA, (U.S. CLS. 22 AND 39). SN 79-077,976. PUB. 1-10-2012. FILED 5-22-2009.

4,116,697 (*See Class 9 for this trademark.*).

4,116,698 (*See Class 18 for this trademark.*).

4,116,699. **SHOCK MANSION AND DESIGN.** SHOCK MANSION PTY LTD, (U.S. CLS. 22 AND 39). SN 79-086,068. PUB. 1-10-2012. FILED 3-25-2010.

4,116,702 (*See Class 16 for this trademark.*).

4,116,703 (*See Class 8 for this trademark.*).

4,116,706 (*See Class 3 for this trademark.*).

4,116,707 (*See Class 8 for this trademark.*).

4,116,711 (*See Class 18 for this trademark.*).

4,116,716 (*See Class 10 for this trademark.*).

4,116,721. **LOINTS OF HOLLAND AND DESIGN.** LOINT'S OF HOLLAND B.V., (U.S. CLS. 22 AND 39). SN 79-090,779. PUB. 1-10-2012. FILED 11-5-2010.

4,116,723 (*See Class 18 for this trademark.*).

4,116,725 (*See Class 16 for this trademark.*).

4,116,726 (*See Class 16 for this trademark.*).

4,116,730 (*See Class 16 for this trademark.*).

4,116,731. **M LEKA AND DESIGN.** GRUPPO DECORTEX S.R.L., MULTIPLE CLASS, (INT. CLS. 25 AND 28), (U.S. CLS. 22, 23, 38, 39 AND 50). SN 79-094,068. PUB. 1-10-2012. FILED 1-20-2011.

4,116,732. **MISCELLANEOUS DESIGN.** GRUPPO DECORTEX S.R.L., MULTIPLE CLASS, (INT. CLS. 25 AND 28), (U.S. CLS. 22, 23, 38, 39 AND 50). SN 79-094,110. PUB. 1-10-2012. FILED 1-20-2011.

4,116,740 (*See Class 18 for this trademark.*).

4,116,757 (*See Class 9 for this trademark.*).

4,116,759 (*See Class 9 for this trademark.*).

4,116,772 (*See Class 18 for this trademark.*).

4,116,783. **ASTER (STYLIZED).** MA, (U.S. CLS. 22 AND 39). SN 79-096,897. PUB. 1-10-2012. FILED 2-17-2011.

4,116,789 (*See Class 3 for this trademark.*).

4,116,805. **MISCELLANEOUS DESIGN.** OKSEBRA RUNNING AB, (U.S. CLS. 22 AND 39). SN 79-098,846. PUB. 1-10-2012. FILED 6-15-2011.

4,116,816. **MISCELLANEOUS DESIGN.** KATSUKAWA EIICHI, (U.S. CLS. 22 AND 39). SN 79-099,528. PUB. 1-10-2012. FILED 5-31-2011.

4,116,826 (*See Class 6 for this trademark.*).

4,116,827. **CAFÉ BLEU AND DESIGN.** VIZON TEKSTIL İTHALAT İHRACAT VE MÜMESSİLİK LIMITED ŞİRKETİ, MULTIPLE CLASS, (INT. CLS. 25 AND 35), (U.S. CLS. 22, 39, 100, 101 AND 102). SN 79-100,272. PUB. 1-10-2012. FILED 2-23-2011.

4,116,845 (*See Class 12 for this trademark.*).

4,116,847. **MERIT INTERNATIONAL AND DESIGN.** MERIT TURİZM YATIRIM VE İŞLETME ANONİM ŞİRKETİ, MULTIPLE CLASS, (INT. CLS. 25 AND 37), (U.S. CLS. 22, 39, 100, 103 AND 106). SN 79-101,188. PUB. 1-10-2012. FILED 2-14-2011.

4,116,885 (*See Class 9 for this trademark.*).

4,116,887. **JVN (STANDARD CHARACTER).** JOVANI FASHION, LTD, (U.S. CLS. 22 AND 39). SN 85-041,604. PUB. 1-10-2012. FILED 5-18-2010.

4,116,905 (*See Class 14 for this trademark.*).

4,116,926 (*See Class 9 for this trademark.*).

4,116,927 (*See Class 9 for this trademark.*).

4,116,928 (*See Class 14 for this trademark.*).

4,116,938. **KITESITES.COM SERIES (STANDARD CHARACTER).** JORDAN, J. CLIVE, MULTIPLE CLASS, (INT. CLS. 25 AND 35), (U.S. CLS. 22, 39, 100, 101 AND 102). SN 85-118,781. PUB. 1-10-2012. FILED 8-30-2010.

4,116,943. **TOP RANK (STANDARD CHARACTER).** TOP RANK INC., (U.S. CLS. 22 AND 39). SN 85-122,672. PUB. 1-10-2012. FILED 9-3-2010.

4,116,944 (*See Class 14 for this trademark.*).

4,116,968. **AGE BADLY AND DESIGN.** FOUNTAINE, BOB, DBA PRECISION IMAGES, LLC, (U.S. CLS. 22 AND 39). SN 85-152,548. PUB. 1-10-2012. FILED 10-14-2010.

4,116,977. **BEST WOOL IN THE WOODS (STANDARD CHARACTER).** RALPH DIMEO, DBA ALEX OUTDOORS, MULTIPLE CLASS, (INT. CLS. 25 AND 35), (U.S. CLS. 22, 39, 100, 101 AND 102). SN 85-166,315. PUB. 1-10-2012. FILED 11-1-2010.

4,116,985. **TOSCANO AND DESIGN.** P.Y.A. IMPORTER LTD., (U.S. CLS. 22 AND 39). SN 85-172,594. PUB. 1-10-2012. FILED 11-9-2010.

4,117,028. **DIRTY LAUNDRY (STANDARD CHARACTER).** GOLDMAN, ROBERT L., (U.S. CLS. 22 AND 39). SN 85-203,326. PUB. 1-10-2012. FILED 12-21-2010.

4,117,032 (*See Class 9 for this trademark.*).

4,117,033. **R AND DESIGN.** SNEAKER HEADZ, LLC, DBA BURN RUBBER, (U.S. CLS. 22 AND 39). SN 85-206,921. PUB. 1-10-2012. FILED 12-29-2010.

4,117,049. **M (STYLIZED).** MYOGRID INC., (U.S. CLS. 22 AND 39). SN 85-215,494. PUB. 1-10-2012. FILED 1-11-2011.

4,117,056. **R AND DESIGN.** DAVIS, MELVIN, (U.S. CLS. 22 AND 39). SN 85-218,123. PUB. 1-10-2012. FILED 1-14-2011.

4,117,059. **THE SAN FRANCISCO MARATHON AND DESIGN.** SAN FRANCISCO MARATHON, INC., MULTIPLE CLASS, (INT. CLS. 25 AND 41), (U.S. CLS. 22, 39, 100, 101 AND 107). SN 85-218,550. PUB. 1-10-2012. FILED 1-14-2011.

4,117,060. **DEKAN CLOTHING AND DESIGN.** LEITNER, NATHAN C, (U.S. CLS. 22 AND 39). SN 85-218,755. PUB. 1-10-2012. FILED 1-16-2011.

4,117,072 (*See Class 14 for this trademark.*).

4,117,074. **THE BOLD FOLD (STANDARD CHARACTER).** BRUXIE, LLC, MULTIPLE CLASS, (INT. CLS. 25, 30 AND 43), (U.S. CLS. 22, 39, 46, 100 AND 101). SN 85-221,466. PUB. 1-10-2012. FILED 1-19-2011.

4,117,090 (*See Class 9 for this trademark.*).

4,117,093. **L'AFRICANA (STANDARD CHARACTER).** COOPER, MACDELLA, AND TAFUTO, THOMAS, F, MULTI-

- PLE CLASS, (INT. CLS. 25, 41, 42 AND 45), (U.S. CLS. 22, 39, 100, 101 AND 107). SN 85-225,153. PUB. 1-10-2012. FILED 1-25-2011.
- 4,117,107. **STAR GANG (STANDARD CHARACTER)**. LOVETT-WOODSUM, CAMERON P., (U.S. CLS. 22 AND 39). SN 85-227,270. PUB. 1-10-2012. FILED 1-26-2011.
- 4,117,110. **THE SOLEFULL LOUNGE (STYLIZED)**. THE SOLEFULL LOUNGE, MULTIPLE CLASS, (INT. CLS. 25 AND 35), (U.S. CLS. 22, 39, 100, 101 AND 102). SN 85-228,383. PUB. 1-10-2012. FILED 1-28-2011.
- 4,117,114. **GOLDEN WEST (STANDARD CHARACTER)**. JACUZZI, MATTHEW, (U.S. CLS. 22 AND 39). SN 85-229,719. PUB. 1-10-2012. FILED 1-31-2011.
- 4,117,118. **MISCELLANEOUS DESIGN**. GFM LICENSING GROUP LLC, MULTIPLE CLASS, (INT. CLS. 25 AND 35), (U.S. CLS. 22, 39, 100, 101 AND 102). SN 85-230,110. PUB. 1-10-2012. FILED 1-31-2011.
- 4,117,126. **ECUA-ANDINO HATS AND DESIGN**. CREANDO ESTILOS S.A. CRESTILSA, (U.S. CLS. 22 AND 39). SN 85-231,071. PUB. 1-10-2012. FILED 2-1-2011.
- 4,117,137. **BOOM BOOM JEANS AND DESIGN**. BLUE PLANET INTERNATIONAL, INC., (U.S. CLS. 22 AND 39). SN 85-232,556. PUB. 1-10-2012. FILED 2-2-2011.
- 4,117,140. **SHOE ME AND DESIGN**. SHOE LOVES ME, (U.S. CLS. 22 AND 39). SN 85-232,818. PUB. 1-10-2012. FILED 2-2-2011.
- 4,117,191. **POWERED BY XYIENCE AND DESIGN**. MANZEN, LLC, (U.S. CLS. 22 AND 39). SN 85-239,544. PUB. 1-10-2012. FILED 2-10-2011.
- 4,117,199. **ANATOMIC INTERFACE MAPPING (STANDARD CHARACTER)**. MYOGRID INC., (U.S. CLS. 22 AND 39). SN 85-240,830. PUB. 1-10-2012. FILED 2-12-2011.
- 4,117,200. **INTRA COOL ENERGY (STANDARD CHARACTER)**. MYOGRID INC., (U.S. CLS. 22 AND 39). SN 85-240,831. PUB. 1-10-2012. FILED 2-12-2011.
- 4,117,201. **HYPER IMPACT TECHNOLOGY (STANDARD CHARACTER)**. MYOGRID INC., (U.S. CLS. 22 AND 39). SN 85-240,834. PUB. 1-10-2012. FILED 2-12-2011.
- 4,117,292. **ABEL BROWN (STANDARD CHARACTER)**. FISCHER, MICHAEL EDWARD, (U.S. CLS. 22 AND 39). SN 85-259,427. PUB. 1-10-2012. FILED 3-7-2011.
- 4,117,311. **RED ROCKET AND DESIGN**. GFM LICENSING GROUP LLC, MULTIPLE CLASS, (INT. CLS. 25 AND 35), (U.S. CLS. 22, 39, 100, 101 AND 102). SN 85-262,163. PUB. 1-10-2012. FILED 3-9-2011.
- 4,117,341. **GETSUM (STANDARD CHARACTER)**. FURRIER, JOE, (U.S. CLS. 22 AND 39). SN 85-269,616. PUB. 1-10-2012. FILED 3-17-2011.
- 4,117,344. **JS REHL (STANDARD CHARACTER)**. JS REHL PRODUCTIONS, (U.S. CLS. 22 AND 39). SN 85-269,867. PUB. 1-10-2012. FILED 3-17-2011.
- 4,117,345. **BABY SPYT (STANDARD CHARACTER)**. WAY, ALEXIS, DBA WWW.BABYSPYT.COM, (U.S. CLS. 22 AND 39). SN 85-270,271. PUB. 1-10-2012. FILED 3-17-2011.
- 4,117,362. **MISCELLANEOUS DESIGN**. IOWA STATE UNIVERSITY OF SCIENCE AND TECHNOLOGY, MULTIPLE CLASS, (INT. CLS. 25 AND 41), (U.S. CLS. 22, 39, 100, 101 AND 107). SN 85-274,288. PUB. 8-9-2011. FILED 3-23-2011.
- 4,117,374 (*See Class 18 for this trademark*).
- 4,117,395. **OUTCOME FIGHT GEAR (STANDARD CHARACTER)**. RICCI, JOE, (U.S. CLS. 22 AND 39). SN 85-281,598. PUB. 1-10-2012. FILED 3-30-2011.
- 4,117,437. **MISCELLANEOUS DESIGN**. WEINBERGER, AUDREY E., AND EISENPRESS, SHERRI L., (U.S. CLS. 22 AND 39). SN 85-291,421. PUB. 1-10-2012. FILED 4-11-2011.
- 4,117,466. **IT'S TIME TO FACE THE MUSIC (STANDARD CHARACTER)**. FREMANTLEMEDIA LIMITED, AND SIMCO LIMITED, (U.S. CLS. 22 AND 39). SN 85-295,193. PUB. 1-10-2012. FILED 4-14-2011.
- 4,117,467 (*See Class 9 for this trademark*).
- 4,117,468. **THE CAMP (STANDARD CHARACTER)**. LITTLE AMERICAN BUSINESSES, INC., MULTIPLE CLASS, (INT. CLS. 25, 35 AND 36), (U.S. CLS. 22, 39, 100, 101 AND 102). SN 85-295,465. PUB. 12-6-2011. FILED 4-14-2011.
- 4,117,477. **MILLIONS OF MILKSHAKES (STANDARD CHARACTER)**. MILLIONS OF MILKSHAKES, INC., MULTIPLE CLASS, (INT. CLS. 25, 29, 30 AND 43), (U.S. CLS. 22, 39, 46, 100 AND 101). SN 85-297,642. PUB. 1-10-2012. FILED 4-18-2011.
- 4,117,487. **AMIRA JEANS USA (STYLIZED)**. SI O. RHEW, (U.S. CLS. 22 AND 39). SN 85-299,929. PUB. 1-10-2012. FILED 4-20-2011.
- 4,117,557. **STARLETTO (STANDARD CHARACTER)**. NAI-SMITH-BEELEY, ILDE, AND NAI-SMITH-BEELEY, MARK, (U.S. CLS. 22 AND 39). SN 85-314,638. PUB. 1-10-2012. FILED 5-6-2011.
- 4,117,560. **FOXY AND DESIGN**. NUNES COMPANY, INC., THE, MULTIPLE CLASS, (INT. CLS. 25 AND 31), (U.S. CLS. 1, 22, 39 AND 46). SN 85-316,290. PUB. 1-10-2012. FILED 5-9-2011.
- 4,117,566. **SILLY FEET (STANDARD CHARACTER)**. BH BRAND INC., (U.S. CLS. 22 AND 39). SN 85-317,802. PUB. 1-10-2012. FILED 5-11-2011.
- 4,117,570. **WHO SAYS I CAN'T (STANDARD CHARACTER)**. ROSENBERG, JOTHY, DBA WHO SAYS I CAN'T, (U.S. CLS. 22 AND 39). SN 85-318,813. PUB. 1-10-2012. FILED 5-12-2011.
- 4,117,590. **MISCELLANEOUS DESIGN**. SHERWOOD, THOMAS W., MULTIPLE CLASS, (INT. CLS. 25, 41 AND 43), (U.S. CLS. 22, 39, 100, 101 AND 107). SN 85-323,015. PUB. 1-10-2012. FILED 5-17-2011.
- 4,117,630. **ZUZII (STANDARD CHARACTER)**. ZUZII LLC, (U.S. CLS. 22 AND 39). SN 85-329,417. PUB. 1-10-2012. FILED 5-24-2011.
- 4,117,672 (*See Class 9 for this trademark*).
- 4,117,691. **BLACK RAINN BY DANIEL RAINN (STANDARD CHARACTER)**. AU MERROW CORPORATION, DBA DANIEL RAINN, (U.S. CLS. 22 AND 39). SN 85-342,550. PUB. 1-10-2012. FILED 6-9-2011.
- 4,117,695. **ALMA LATINA (STANDARD CHARACTER)**. 7TH REVOLUTION CLOTHING LLC, MULTIPLE CLASS, (INT. CLS. 25 AND 35), (U.S. CLS. 22, 39, 100, 101 AND 102). SN 85-343,360. PUB. 1-10-2012. FILED 6-10-2011.
- 4,117,696. **MW (STYLIZED)**. PABLO BIGIO, (U.S. CLS. 22 AND 39). SN 85-343,471. PUB. 1-10-2012. FILED 6-10-2011.
- 4,117,706 (*See Class 18 for this trademark*).
- 4,117,734. **MAKE THE MERGE (STANDARD CHARACTER)**. MER + GE LLC, DBA MER + GE, (U.S. CLS. 22 AND 39). SN 85-349,792. PUB. 1-10-2012. FILED 6-17-2011.
- 4,117,742 (*See Class 3 for this trademark*).
- 4,117,749. **MIDNIGHT RIDAZZ AND DESIGN**. WARD, DON, (U.S. CLS. 22 AND 39). SN 85-351,713. PUB. 1-10-2012. FILED 6-21-2011.
- 4,117,757. **POSESION (STANDARD CHARACTER)**. MANUFACTURAS ECONOMICAS S. EN C.S., (U.S. CLS. 22 AND 39). SN 85-352,384. PUB. 1-10-2012. FILED 6-22-2011.
- 4,117,788. **TATTOO KNUCKLE GLOVES (STANDARD CHARACTER)**. PERINE, ROBIN, (U.S. CLS. 22 AND 39). SN 85-356,434. PUB. 1-10-2012. FILED 6-26-2011.
- 4,117,853. **CAPOTE (STANDARD CHARACTER)**. RIDDLE, EVELYN, (U.S. CLS. 22 AND 39). SN 85-364,662. PUB. 1-10-2012. FILED 7-6-2011.
- 4,117,863. **MORE THAN AN ATTITUDE...MORE THAN A LIFESTYLE...THAT'S MEMOI (STANDARD CHARACTER)**. INFINITY CLASSICS INTERNATIONAL, INC., MULTIPLE CLASS, (INT. CLS. 25 AND 35), (U.S. CLS. 22, 39, 100, 101 AND 102). SN 85-365,108. PUB. 1-10-2012. FILED 7-7-2011.
- 4,117,906. **CHEF NETWORK (STANDARD CHARACTER)**. NEW YORK LINK, INC., (U.S. CLS. 22 AND 39). SN 85-367,720. PUB. 1-10-2012. FILED 7-11-2011.
- 4,117,913. **512 LOCAL (STANDARD CHARACTER)**. 512 LOCAL, LLC, (U.S. CLS. 22 AND 39). SN 85-368,159. PUB. 12-6-2011. FILED 7-11-2011.
- 4,117,929. **FULL SAIL CENTER FOR THE RECORDING ARTS AND DESIGN**. FULL SAIL, LLC, (U.S. CLS. 22 AND 39). SN 85-368,952. PUB. 1-10-2012. FILED 7-12-2011.
- 4,117,958 (*See Class 9 for this trademark*).
- 4,118,012. **NUWORLD A TRIGLOBE PRODUCT (STANDARD CHARACTER)**. TRIGLOBE INTERNATIONAL, INC., (U.S. CLS. 22 AND 39). SN 85-372,198. PUB. 1-10-2012. FILED 7-15-2011.
- 4,118,018. **NEW@TITUDE (STANDARD CHARACTER)**. BOSCOV'S INVESTMENT COMPANY, INC., (U.S. CLS. 22 AND 39). SN 85-372,337. PUB. 1-10-2012. FILED 7-15-2011.
- 4,118,037. **BLUE CANOE (STYLIZED)**. OE, INC., (U.S. CLS. 22

- AND 39). SN 85-373,004. PUB. 1-10-2012. FILED 7-15-2011.
- 4,118,038. **LIFTOUCH AND DESIGN. S&R DISTRIBUTION COMPANY, INC.**, (U.S. CLS. 22 AND 39). SN 85-373,019. PUB. 1-10-2012. FILED 7-15-2011.
- 4,118,063. **BADBOB'S BARBEQUE RESTAURANT (STANDARD CHARACTER).** BADBOB'S LLC, MULTIPLE CLASS, (INT. CLS. 25 AND 30), (U.S. CLS. 22, 39 AND 46). SN 85-373,626. PUB. 1-10-2012. FILED 7-18-2011.
- 4,118,097. **AGUACLARA (STANDARD CHARACTER).** VILLALOBOS, LILIANA C., (U.S. CLS. 22 AND 39). SN 85-374,285. PUB. 1-10-2012. FILED 7-18-2011.
- 4,118,115. **OCCUSELECT (STANDARD CHARACTER).** OCCUNOMIX INTERNATIONAL LLC, (U.S. CLS. 22 AND 39). SN 85-374,699. PUB. 1-10-2012. FILED 7-19-2011.
- 4,118,138. **ROCKSCAR LOVE (STANDARD CHARACTER).** TIPPINS, AMY NICOLE, DBA ROCKSCAR LOVE DESIGNS, (U.S. CLS. 22 AND 39). SN 85-375,252. PUB. 1-10-2012. FILED 7-19-2011.
- 4,118,161. **B.T. CRUISERS ROCHESTER, N.Y. AND DESIGN.** LADUE, HEATHER, MULTIPLE CLASS, (INT. CLS. 25 AND 41), (U.S. CLS. 22, 39, 100, 101 AND 107). SN 85-375,487. PUB. 1-10-2012. FILED 7-19-2011.
- 4,118,162. **CAGE CANDY (STANDARD CHARACTER).** TATE, TRACY ELIZABETH, DBA CAGE CANDY, (U.S. CLS. 22 AND 39). SN 85-375,492. PUB. 1-10-2012. FILED 7-19-2011.
- 4,118,190. **CHELSEA BABY (STANDARD CHARACTER).** CHELSEA BABY, LLC, MULTIPLE CLASS, (INT. CLS. 25 AND 26), (U.S. CLS. 22, 37, 39, 40, 42 AND 50). SN 85-376,314. PUB. 1-10-2012. FILED 7-20-2011.
- 4,118,199. **DEATH TO FALSE PIZZA (STANDARD CHARACTER).** NICE BOWTIE, LLC, MULTIPLE CLASS, (INT. CLS. 25 AND 43), (U.S. CLS. 22, 39, 100 AND 101). SN 85-376,778. PUB. 1-10-2012. FILED 7-20-2011.
- 4,118,225. **AGONY (STANDARD CHARACTER).** KEYES, DARRYL, DBA AGONY CLOTHING COMPANY, (U.S. CLS. 22 AND 39). SN 85-377,705. PUB. 1-10-2012. FILED 7-21-2011.
- 4,118,226. **LYMPHOMATHON TAKE A STEP, FIND A CURE AND DESIGN.** LYMPHOMA RESEARCH FOUNDATION, MULTIPLE CLASS, (INT. CLS. 25, 36 AND 41), (U.S. CLS. 22, 39, 100, 101, 102 AND 107). SN 85-377,707. PUB. 1-10-2012. FILED 7-21-2011.
- 4,118,253. **M MOJO FUTURETECH AND DESIGN.** PACIFIC VIBRATIONS LLC, (U.S. CLS. 22 AND 39). SN 85-378,935. PUB. 1-10-2012. FILED 7-22-2011.
- 4,118,259. **IF YOU DON'T BELIEVE IN YOURSELF NO ONE ELSE WILL (STANDARD CHARACTER).** FOREVER FAITH LLC, (U.S. CLS. 22 AND 39). SN 85-379,071. PUB. 1-10-2012. FILED 7-22-2011.
- 4,118,269. **VACODO (STANDARD CHARACTER).** CAO, JIAN, (U.S. CLS. 22 AND 39). SN 85-379,904. PUB. 1-10-2012. FILED 7-25-2011.
- 4,118,271 (*See Class 14 for this trademark*).
- 4,118,293. **LUSCIOUS (STANDARD CHARACTER).** IMPERIAL PANTS CO., LTD., (U.S. CLS. 22 AND 39). SN 85-381,051. PUB. 1-10-2012. FILED 7-26-2011.
- 4,118,308. **SALTY DUDE (STANDARD CHARACTER).** CAMPISI, RICHARD, M, DBA R. M. CAMPISI, (U.S. CLS. 22 AND 39). SN 85-385,323. PUB. 1-10-2012. FILED 7-30-2011.
- 4,118,309. **DEUKALION AND DESIGN.** DEUKALION, (U.S. CLS. 22 AND 39). SN 85-385,528. PUB. 1-10-2012. FILED 7-31-2011.
- 4,118,316. **BEACH TENNIS USA (STANDARD CHARACTER).** BEACH TENNIS USA, LLC, MULTIPLE CLASS, (INT. CLS. 25 AND 41), (U.S. CLS. 22, 39, 100, 101 AND 107). SN 85-386,967. PUB. 1-10-2012. FILED 8-2-2011.
- 4,118,318. **SLOW LORIS AND DESIGN.** SLOW LORIS, INC., (U.S. CLS. 22 AND 39). SN 85-387,422. PUB. 1-10-2012. FILED 8-2-2011.
- 4,118,338. **CREME AND DESIGN.** ASEFUDDIN, MOHAMMED, (U.S. CLS. 22 AND 39). SN 85-388,809. PUB. 1-10-2012. FILED 8-3-2011.
- 4,118,339. **SPEED COLLECTION (STANDARD CHARACTER).** OCCUNOMIX INTERNATIONAL LLC, (U.S. CLS. 22 AND 39). SN 85-388,857. PUB. 1-10-2012. FILED 8-3-2011.
- 4,118,355 (*See Class 9 for this trademark*).
- 4,118,364. **BANANABEAT (STANDARD CHARACTER).** BANANABEAT RECORDS, (U.S. CLS. 22 AND 39). SN 85-390,288. PUB. 1-10-2012. FILED 8-5-2011.
- 4,118,371. **ONAKWEST (STANDARD CHARACTER).** ONAKWEST, LLC, (U.S. CLS. 22 AND 39). SN 85-390,801. PUB. 1-10-2012. FILED 8-5-2011.
- 4,118,391. **PAY ATTENTION (STANDARD CHARACTER).** YODER, JJ, DBA PAY ATTENTION CLOTHING, (U.S. CLS. 22 AND 39). SN 85-391,988. PUB. 1-10-2012. FILED 8-8-2011.
- 4,118,443. **CITERATI (STANDARD CHARACTER).** CHRISTOPHER GREAVES, (U.S. CLS. 22 AND 39). SN 85-393,113. PUB. 1-10-2012. FILED 8-9-2011.
- 4,118,446. **SEXY LOCKER (STANDARD CHARACTER).** MANTILLA DIAZ, MARCO, (U.S. CLS. 22 AND 39). SN 85-393,194. PUB. 1-10-2012. FILED 8-9-2011.
- 4,118,458 (*See Class 18 for this trademark*).
- 4,118,479. **PIPE MASTERS (STANDARD CHARACTER).** VANS, INC., MULTIPLE CLASS, (INT. CLS. 25 AND 41), (U.S. CLS. 22, 39, 100, 101 AND 107). SN 85-393,751. PUB. 1-10-2012. FILED 8-9-2011.
- 4,118,497. **FEAR CITY (STANDARD CHARACTER).** BIG CITY ENTERTAINMENT, LLC, MULTIPLE CLASS, (INT. CLS. 25 AND 41), (U.S. CLS. 22, 39, 100, 101 AND 107). SN 85-394,125. PUB. 1-10-2012. FILED 8-10-2011.
- 4,118,524. **THE ROOFTOP REVOLUTION (STANDARD CHARACTER).** 1ST LIGHT ENERGY, INC., (U.S. CLS. 22 AND 39). SN 85-394,799. PUB. 1-10-2012. FILED 8-10-2011.
- 4,118,531. **JANUS (STANDARD CHARACTER).** JANUSFABRIKKN AS, (U.S. CLS. 22 AND 39). SN 85-394,879. PUB. 1-10-2012. FILED 8-10-2011.
- 4,118,543. **22 AND DESIGN.** TUPPER, JAMES, DBA POST 22, (U.S. CLS. 22 AND 39). SN 85-395,047. PUB. 1-10-2012. FILED 8-11-2011.
- 4,118,546. **FIT FATALE (STANDARD CHARACTER).** FIT FATALE LLC, (U.S. CLS. 22 AND 39). SN 85-395,064. PUB. 1-10-2012. FILED 8-11-2011.
- 4,118,551. **REP CHI (STANDARD CHARACTER).** REPLICACHICAGO INC, (U.S. CLS. 22 AND 39). SN 85-395,307. PUB. 1-10-2012. FILED 8-11-2011.
- 4,118,582. **SAFEDENIM (STANDARD CHARACTER).** AMERICAN COTTON GROWERS, A DIVISION OF PLAINS COTTON COOPERATIVE ASSOCIATION, (U.S. CLS. 22 AND 39). SN 85-395,844. PUB. 1-10-2012. FILED 8-11-2011.
- 4,118,599. **HOMEGROWN MILITANT (STANDARD CHARACTER).** PEARSON, JAKE, (U.S. CLS. 22 AND 39). SN 85-396,087. PUB. 1-10-2012. FILED 8-12-2011.
- 4,118,613. **BETTER WHY? (STANDARD CHARACTER).** CUPID FOUNDATIONS, INC., (U.S. CLS. 22 AND 39). SN 85-396,578. PUB. 1-10-2012. FILED 8-12-2011.
- 4,118,618. **AGAINST NATURE (STANDARD CHARACTER).** DOYLE MUESER LTD., DBA DOYLE MUESER LTD., (U.S. CLS. 22 AND 39). SN 85-396,687. PUB. 1-10-2012. FILED 8-12-2011.
- 4,118,632. **SKELE-TOES (STANDARD CHARACTER).** FILA LUXEMBOURG S.A.R.L., (U.S. CLS. 22 AND 39). SN 85-396,918. PUB. 1-10-2012. FILED 8-12-2011.
- 4,118,651. **KO AND DESIGN.** NOEVEEN CORDBACHE, DBA KNOCKOUT STAR, (U.S. CLS. 22 AND 39). SN 85-397,180. PUB. 1-10-2012. FILED 8-12-2011.
- 4,118,657. **TAKING CARE OF BIBNESS (STANDARD CHARACTER).** CLARKE, TREVOR S., (U.S. CLS. 22 AND 39). SN 85-397,270. PUB. 1-10-2012. FILED 8-13-2011.
- 4,118,706. **LYL! (STANDARD CHARACTER).** KAHN LUCAS LANCASTER, INC., (U.S. CLS. 22 AND 39). SN 85-427,449. PUB. 1-10-2012. FILED 9-20-2011.
- 4,118,734. **THE DIRTY DASH DD AND DESIGN.** SPRINGBOK GROUP, (U.S. CLS. 22 AND 39). SN 85-457,114. PUB. 1-10-2012. FILED 10-26-2011.

CLASS 26—FANCY GOODS

- 4,116,757 (*See Class 9 for this trademark*).
- 4,116,905 (*See Class 14 for this trademark*).
- 4,117,672 (*See Class 9 for this trademark*).
- 4,117,706 (*See Class 18 for this trademark*).
- 4,117,740. **LITTLE MISS PATCH IT! AND DESIGN.** THOMPSON, TAMMY L, DBA LITTLE MISS PATCH IT, (U.S. CLS.

37, 39, 40, 42 AND 50). SN 85-350,918. PUB. 1-10-2012. FILED 6-20-2011.
 4,117,964 (*See Class 14 for this trademark*).
 4,117,982. **BOWBUDDIES (STANDARD CHARACTER)**. BOW BUDDIES, LLC. (U.S. CLS. 37, 39, 40, 42 AND 50). SN 85-371,086. PUB. 1-10-2012. FILED 7-14-2011.
 4,118,005. **BI (STYLIZED)**. NOBLE BEAUTY OF AMERICA, INC., (U.S. CLS. 37, 39, 40, 42 AND 50). SN 85-371,910. PUB. 1-10-2012. FILED 7-14-2011.
 4,118,067. **YINZER GIRL (STANDARD CHARACTER)**. BELLEFLEUR, JUDY-ANN, DBA J.B. WIGS, (U.S. CLS. 37, 39, 40, 42 AND 50). SN 85-373,678. PUB. 1-10-2012. FILED 7-18-2011.
 4,118,120. **FICCARE (STANDARD CHARACTER)**. VISION-MAX, INC., (U.S. CLS. 37, 39, 40, 42 AND 50). SN 85-374,770. PUB. 1-10-2012. FILED 7-19-2011.
 4,118,190 (*See Class 25 for this trademark*).
 4,118,294 (*See Class 3 for this trademark*).
 4,118,470. **PONY SHELLS (STANDARD CHARACTER)**. 2 CHIKS, LLC. (U.S. CLS. 37, 39, 40, 42 AND 50). SN 85-393,514. PUB. 1-10-2012. FILED 8-9-2011.
 4,118,591. **SHOWSTOPPERS (STANDARD CHARACTER)**. SHOWSTOPPERS, LLC. (U.S. CLS. 37, 39, 40, 42 AND 50). SN 85-395,977. PUB. 1-10-2012. FILED 8-11-2011.

CLASS 27—FLOOR COVERINGS

4,117,248. **EASYTURF (STANDARD CHARACTER)**. EASYTURF, INC., (U.S. CLS. 19, 20, 37, 42 AND 50). SN 85-248,698. PUB. 1-10-2012. FILED 2-22-2011.

CLASS 28—TOYS AND SPORTING GOODS

4,116,579. **MISCELLANEOUS DESIGN**. IVANKO BARBELL COMPANY, (U.S. CLS. 22, 23, 38 AND 50). SN 76-708,213. PUB. 1-10-2012. FILED 7-1-2011.
 4,116,593 (*See Class 9 for this trademark*).
 4,116,628. **FASTRACK (STANDARD CHARACTER)**. LIONEL TRADEMARK LLC, (U.S. CLS. 22, 23, 38 AND 50). SN 77-799,339. PUB. 1-10-2012. FILED 8-7-2009.
 4,116,697 (*See Class 9 for this trademark*).
 4,116,711 (*See Class 18 for this trademark*).
 4,116,731 (*See Class 25 for this trademark*).
 4,116,732 (*See Class 25 for this trademark*).
 4,116,757 (*See Class 9 for this trademark*).
 4,116,760 (*See Class 9 for this trademark*).
 4,116,795 (*See Class 16 for this trademark*).
 4,116,798. **PERIGON (STANDARD CHARACTER)**. WILL SORRELL, (U.S. CLS. 22, 23, 38 AND 50). SN 79-097,921. PUB. 1-10-2012. FILED 5-6-2011.
 4,116,825 (*See Class 20 for this trademark*).
 4,116,916 (*See Class 9 for this trademark*).
 4,116,926 (*See Class 9 for this trademark*).
 4,116,927 (*See Class 9 for this trademark*).
 4,117,021. **MY VERY REAL BABY (STANDARD CHARACTER)**. MATTEL, INC., (U.S. CLS. 22, 23, 38 AND 50). SN 85-200,652. PUB. 10-4-2011. FILED 12-17-2010.
 4,117,037. **BOB LEE (STANDARD CHARACTER)**. BOB LEE ARCHERY, LP, (U.S. CLS. 22, 23, 38 AND 50). SN 85-209,054. PUB. 1-10-2012. FILED 1-3-2011.
 4,117,038. **BOB LEE BOWS AND DESIGN**. BOB LEE ARCHERY, LP, (U.S. CLS. 22, 23, 38 AND 50). SN 85-209,071. PUB. 1-10-2012. FILED 1-3-2011.
 4,117,041. **BOB LEE ARCHERY AND DESIGN**. BOB LEE ARCHERY, LP, (U.S. CLS. 22, 23, 38 AND 50). SN 85-210,570. PUB. 1-10-2012. FILED 1-5-2011.
 4,117,075. **GOBLINTHREAD (STANDARD CHARACTER)**. MIDLAND DESIGN, LLC, (U.S. CLS. 22, 23, 38 AND 50). SN 85-221,569. PUB. 1-10-2012. FILED 1-19-2011.
 4,117,103. **DYNAMIC LAUNCH TECHNOLOGY (STANDARD CHARACTER)**. TSA STORES INC., (U.S. CLS. 22, 23, 38 AND 50). SN 85-226,515. PUB. 1-10-2012. FILED 1-26-2011.
 4,117,115. **GRANDRC (STANDARD CHARACTER)**. MEK-

KITTKIKUL, ADISAK, (U.S. CLS. 22, 23, 38 AND 50). SN 85-229,729. PUB. 1-10-2012. FILED 1-31-2011.
 4,117,141 (*See Class 9 for this trademark*).
 4,117,170. **MOVIE STAR (STANDARD CHARACTER)**. MATTEL, INC., (U.S. CLS. 22, 23, 38 AND 50). SN 85-236,041. PUB. 1-10-2012. FILED 2-7-2011.
 4,117,216. **GABRIEL (STANDARD CHARACTER)**. "BECAUSE WE CARE" MINISTRIES, (U.S. CLS. 22, 23, 38 AND 50). SN 85-242,528. PUB. 1-10-2012. FILED 2-15-2011.
 4,117,220. **MATCH 'N SNAP (STANDARD CHARACTER)**. SHURE PRODUCTS INC., (U.S. CLS. 22, 23, 38 AND 50). SN 85-243,673. PUB. 1-10-2012. FILED 2-16-2011.
 4,117,270. **MISCELLANEOUS DESIGN**. FERRARI IMPORTING COMPANY, DBA GAMMA SPORTS, (U.S. CLS. 22, 23, 38 AND 50). SN 85-254,012. PUB. 1-10-2012. FILED 2-28-2011.
 4,117,281. **CIRCUIT CHAMPIONS (STANDARD CHARACTER)**. MATTEL, INC., (U.S. CLS. 22, 23, 38 AND 50). SN 85-256,719. PUB. 1-10-2012. FILED 3-3-2011.
 4,117,291. **HUNGRY HUNGRY HIPPOS (STANDARD CHARACTER)**. HASBRO, INC., (U.S. CLS. 22, 23, 38 AND 50). SN 85-259,353. PUB. 1-10-2012. FILED 3-7-2011.
 4,117,363 (*See Class 9 for this trademark*).
 4,117,396 (*See Class 16 for this trademark*).
 4,117,406. **PAJAMA NIGHTS (STANDARD CHARACTER)**. MATTEL, INC., (U.S. CLS. 22, 23, 38 AND 50). SN 85-283,802. PUB. 1-10-2012. FILED 4-1-2011.
 4,117,407. **T-REX TAKEDOWN (STANDARD CHARACTER)**. MATTEL, INC., (U.S. CLS. 22, 23, 38 AND 50). SN 85-283,808. PUB. 1-10-2012. FILED 4-1-2011.
 4,117,408 (*See Class 5 for this trademark*).
 4,117,411 (*See Class 17 for this trademark*).
 4,117,412 (*See Class 16 for this trademark*).
 4,117,413 (*See Class 16 for this trademark*).
 4,117,524. **FLOATING LUXURIES (STANDARD CHARACTER)**. FLOATING LUXURIES, INC., (U.S. CLS. 22, 23, 38 AND 50). SN 85-307,051. PUB. 1-10-2012. FILED 4-28-2011.
 4,117,596. **KAI LOUNGE (STANDARD CHARACTER)**. FLOATING LUXURIES INC., (U.S. CLS. 22, 23, 38 AND 50). SN 85-323,807. PUB. 1-10-2012. FILED 5-18-2011.
 4,117,638. **BOWORKER (STANDARD CHARACTER)**. HUGHES MARKETING, LLC, (U.S. CLS. 22, 23, 38 AND 50). SN 85-331,701. PUB. 1-10-2012. FILED 5-26-2011.
 4,117,742 (*See Class 3 for this trademark*).
 4,117,857 (*See Class 9 for this trademark*).
 4,117,878. **G/FORE (STANDARD CHARACTER)**. DIRTY BIRD PRODUCTIONS, (U.S. CLS. 22, 23, 38 AND 50). SN 85-366,275. PUB. 1-10-2012. FILED 7-8-2011.
 4,117,915. **HI-OCTANE BOOSTERS (STANDARD CHARACTER)**. EF COMPOSITE TECHNOLOGIES, L.P., (U.S. CLS. 22, 23, 38 AND 50). SN 85-368,284. PUB. 1-10-2012. FILED 7-11-2011.
 4,117,946. **OPTI ART AND DESIGN**. A.W. FABER-CASTELL USA, INC., (U.S. CLS. 22, 23, 38 AND 50). SN 85-369,412. PUB. 1-10-2012. FILED 7-12-2011.
 4,118,027. **FITIX (STANDARD CHARACTER)**. MASARTI INTERNATIONAL ENTERPRISE, LLC, (U.S. CLS. 22, 23, 38 AND 50). SN 85-372,668. PUB. 1-10-2012. FILED 7-15-2011.
 4,118,029. **MISCELLANEOUS DESIGN**. MASARTI INTERNATIONAL ENTERPRISE, LLC, (U.S. CLS. 22, 23, 38 AND 50). SN 85-372,724. PUB. 1-10-2012. FILED 7-15-2011.
 4,118,030. **FITIX AND DESIGN**. MASARTI INTERNATIONAL ENTERPRISE, LLC, (U.S. CLS. 22, 23, 38 AND 50). SN 85-372,780. PUB. 1-10-2012. FILED 7-15-2011.
 4,118,076. **SPELLIGATOR (STANDARD CHARACTER)**. JUNIOR LEARNING, INC., (U.S. CLS. 22, 23, 38 AND 50). SN 85-373,857. PUB. 1-10-2012. FILED 7-18-2011.
 4,118,113. **VINCI AND DESIGN**. VINCI CO., LLC, (U.S. CLS. 22, 23, 38 AND 50). SN 85-374,690. PUB. 1-10-2012. FILED 7-19-2011.
 4,118,175. **PYRAMIDS AND DESIGN**. SHIELD MFG. INC., (U.S. CLS. 22, 23, 38 AND 50). SN 85-375,797. PUB. 1-10-2012. FILED 7-20-2011.
 4,118,195. **ANCHOR SIGHT (STANDARD CHARACTER)**. ARCHERY INNOVATIONS, (U.S. CLS. 22, 23, 38 AND 50). SN 85-376,564. PUB. 1-10-2012. FILED 7-20-2011.
 4,118,301 (*See Class 20 for this trademark*).
 4,118,310. **TACTICS (STANDARD CHARACTER)**. EFUEGO CORP., (U.S. CLS. 22, 23, 38 AND 50). SN 85-385,943. PUB. 1-

- 10-2012. FILED 8-1-2011.
 4,118,314. **BEACH TENNIS USA AND DESIGN.** BEACH TENNIS USA, LLC, (U.S. CLS. 22, 23, 38 AND 50). SN 85-386,860. PUB. 1-10-2012. FILED 8-2-2011.
 4,118,355 (*See Class 9 for this trademark*).
 4,118,519. **THUMB CRUMBA (STANDARD CHARACTER).** PRETTY UGLY LLC, AND HORVATH, DAVID, AND KIM, SUN-MIN, (U.S. CLS. 22, 23, 38 AND 50). SN 85-394,627. PUB. 1-10-2012. FILED 8-10-2011.
 4,118,593. **IKOY YOKI (STANDARD CHARACTER).** PRETTY UGLY LLC, AND HORVATH, DAVID, AND KIM, SUN-MIN, (U.S. CLS. 22, 23, 38 AND 50). SN 85-396,016. PUB. 1-10-2012. FILED 8-11-2011.
 4,118,715. **HIT THE DECK (STANDARD CHARACTER).** FUNDEX GAMES, LTD., (U.S. CLS. 22, 23, 38 AND 50). SN 85-434,970. PUB. 1-10-2012. FILED 9-29-2011.
 4,118,716. **ON THE BUBBLE (STANDARD CHARACTER).** FUNDEX GAMES, LTD., (U.S. CLS. 22, 23, 38 AND 50). SN 85-435,000. PUB. 1-10-2012. FILED 9-29-2011.

CLASS 29—MEATS AND PROCESSED FOODS

- 4,116,691. **CULATELLO DI ZIBELLO (STANDARD CHARACTER).** MINISTERO DELLE POLITICHE AGRICOLE;; ALIMENTARI E FORESTALI -; DIPARTIMENTO DELLE POLITICHE; COMPETITIVE DEL MONDO RURALE; E DELLA QUALITA' -; DIREZIONE GENERALE PER LO; SVILUPPO AGROALIMENTARE;; LA QUALITA' E LA TUTELA; DEL CONSUMATORE, (U.S. CL. 46). SN 79-083,391. PUB. 1-10-2012. FILED 4-16-2010.
 4,116,692 (*See Class 5 for this trademark*).
 4,116,694. **PETIT BILLY (STANDARD CHARACTER).** TRIBALLAT NOYAL, MULTIPLE CLASS, (INT. CLS. 29 AND 30), (U.S. CL. 46). SN 79-085,311. PUB. 1-10-2012. FILED 6-11-2010.
 4,116,704 (*See Class 1 for this trademark*).
 4,116,762 (*See Class 5 for this trademark*).
 4,116,785. **KORKUNOV (STANDARD CHARACTER).** ODINTSOVO CONFECTIONERY PLANT, LTD., MULTIPLE CLASS, (INT. CLS. 29, 30 AND 35), (U.S. CLS. 46, 100, 101 AND 102). SN 79-097,277. PUB. 1-10-2012. FILED 3-17-2011.
 4,116,939. **OUR ASSAULT ON SALT CONTINUES... (STANDARD CHARACTER).** FRANK BRUNCKHORST CO., L.L.C., (U.S. CL. 46). SN 85-119,667. PUB. 1-10-2012. FILED 8-31-2010.
 4,116,940. **LAUNCH YOUR OWN ASSAULT ON SALT. (STANDARD CHARACTER).** FRANK BRUNCKHORST CO., L.L.C., (U.S. CL. 46). SN 85-119,695. PUB. 1-10-2012. FILED 8-31-2010.
 4,116,990. **AHONUI GARDENS (STANDARD CHARACTER).** AHONUI GARDENS, INC., DBA AHONUI GARDENS, MULTIPLE CLASS, (INT. CLS. 29, 31 AND 44), (U.S. CLS. 1, 46, 100 AND 101). SN 85-184,064. PUB. 1-10-2012. FILED 11-23-2010.
 4,116,999. **FWM SMOKED MEATS AND DESIGN.** RAEMICA, INC., (U.S. CL. 46). SN 85-188,789. PUB. 1-10-2012. FILED 12-1-2010.
 4,117,017. **THE FLAVOR OF THE PHILIPPINES (STANDARD CHARACTER).** RAMAR INTERNATIONAL CORPORATION, MULTIPLE CLASS, (INT. CLS. 29, 30 AND 32), (U.S. CLS. 45, 46 AND 48). SN 85-198,902. PUB. 10-4-2011. FILED 12-15-2010.
 4,117,031. **BIONA ORGANIC AND DESIGN.** MCDONALD, NOEL, MULTIPLE CLASS, (INT. CLS. 29, 30 AND 32), (U.S. CLS. 45, 46 AND 48). SN 85-205,254. PUB. 1-10-2012. FILED 12-23-2010.
 4,117,067. **MISCELLANEOUS DESIGN.** THE LEO PETERS LIVING TRUST, (U.S. CL. 46). SN 85-220,592. PUB. 1-10-2012. FILED 1-19-2011.
 4,117,131. **WETZEL ESTATE AVV OLIVE OIL 2007 HARVEST - EXTRA VIRGIN OLIVE ALEXANDER VALLEY VINEYARDS AND DESIGN.** AVV WINERY CO., LLC, (U.S. CL. 46). SN 85-231,673. PUB. 1-10-2012. FILED 2-1-2011.
 4,117,221. **ORIGINAL RECIPE OF JANG MO GIP RESTAURANT. EST. 1989. AND DESIGN.** MILKIMCHI INC, DBA MOTHER-IN-LAW'S KIMCHI, (U.S. CL. 46). SN 85-244,429.

- PUB. 1-10-2012. FILED 2-16-2011.
 4,117,264. **MISCELLANEOUS DESIGN.** KERTSMAN, ILIA, (U.S. CL. 46). SN 85-252,481. PUB. 1-10-2012. FILED 2-26-2011.
 4,117,283. **BETTER TASTE. BETTER NUTRITION. BETTER EGGS. (STANDARD CHARACTER).** BEST MARKETING SERVICES, INC., (U.S. CL. 46). SN 85-257,436. PUB. 1-10-2012. FILED 3-3-2011.
 4,117,369. **ALLGOOD PROVISIONS (STANDARD CHARACTER).** ALLGOOD PROVISIONS LLC, DBA ALLGOOD PROVISIONS, (U.S. CL. 46). SN 85-276,980. PUB. 1-10-2012. FILED 3-25-2011.
 4,117,386. **PEDROS (STANDARD CHARACTER).** PACIFIC NORTHWEST FARMERS COOPERATIVE, INC., (U.S. CL. 46). SN 85-280,325. PUB. 1-10-2012. FILED 3-29-2011.
 4,117,401. **MISCELLANEOUS DESIGN.** T. MARZETTI COMPANY, (U.S. CL. 46). SN 85-282,727. PUB. 1-10-2012. FILED 3-31-2011.
 4,117,403. **NUTRIOLI DHA (STANDARD CHARACTER).** RAGASA INDUSTRIAS, S.A. DE C.V., (U.S. CL. 46). SN 85-283,007. PUB. 1-10-2012. FILED 3-31-2011.
 4,117,434. **CHARLIE AND DESIGN.** STARKIST CO., (U.S. CL. 46). SN 85-290,410. PUB. 1-10-2012. FILED 4-8-2011.
 4,117,477 (*See Class 25 for this trademark*).
 4,117,556. **SCREAMING DUTCHMAN AND DESIGN.** BARON COUNTY CHEESE LLC, (U.S. CL. 46). SN 85-314,512. PUB. 1-10-2012. FILED 5-6-2011.
 4,117,636 (*See Class 5 for this trademark*).
 4,117,814. **RISHTA PREMIUM QUALITY AND DESIGN.** P&B (FOODS) LIMITED, MULTIPLE CLASS, (INT. CLS. 29 AND 30), (U.S. CL. 46). SN 85-359,737. PUB. 1-10-2012. FILED 6-29-2011.
 4,117,999. **SAVORY ADDICTIONS (STANDARD CHARACTER).** SAVORY ADDICTIONS, LLC, (U.S. CL. 46). SN 85-371,676. PUB. 1-10-2012. FILED 7-14-2011.
 4,118,013. **LAFINITA AND DESIGN.** ARGUETA SOSA, HILDAN DAVID, (U.S. CL. 46). SN 85-372,200. PUB. 1-10-2012. FILED 7-15-2011.
 4,118,058. **SUPER SAMPLERS (STANDARD CHARACTER).** SHAREHOLDERS BRANDS, LLC, (U.S. CL. 46). SN 85-373,565. PUB. 1-10-2012. FILED 7-18-2011.
 4,118,106. **FAMOUS MADERA OF CALIFORNIA SELECT THOMPSON SEEDLESS RAISINS EST. 1963 AND DESIGN.** VICTOR PACKING, INC., (U.S. CL. 46). SN 85-374,426. PUB. 1-10-2012. FILED 7-18-2011.
 4,118,112. **DELICIOUS TAMALES (STANDARD CHARACTER).** DELICIOUS INC., MULTIPLE CLASS, (INT. CLS. 29 AND 30), (U.S. CL. 46). SN 85-374,635. PUB. 1-10-2012. FILED 7-19-2011.
 4,118,272. **FARMER PEET'S AND DESIGN.** ALEXANDER & HORNUNG, INC., (U.S. CL. 46). SN 85-380,030. PUB. 1-10-2012. FILED 7-25-2011.
 4,118,340. **EL TERCO AND DESIGN.** ALEJANDRO HERRERA DOHRENBURG, MULTIPLE CLASS, (INT. CLS. 29 AND 43), (U.S. CLS. 46, 100 AND 101). SN 85-388,981. PUB. 1-10-2012. FILED 8-3-2011.
 4,118,369. **MISCELLANEOUS DESIGN.** BUMBLE BEE FOODS, LLC, (U.S. CL. 46). SN 85-390,725. PUB. 1-10-2012. FILED 8-5-2011.
 4,118,549. **BELLA MIGLIORE (STANDARD CHARACTER).** HORMEL FOODS, LLC, MULTIPLE CLASS, (INT. CLS. 29 AND 30), (U.S. CL. 46). SN 85-395,273. PUB. 1-10-2012. FILED 8-11-2011.
 4,118,678. **BEST BEGINNINGS (STANDARD CHARACTER).** BJ'S RESTAURANTS, INC., (U.S. CL. 46). SN 85-404,253. PUB. 1-10-2012. FILED 8-22-2011.
 4,118,687. **JUST BARE (STANDARD CHARACTER).** JFC, INC., (U.S. CL. 46). SN 85-409,476. PUB. 1-10-2012. FILED 8-29-2011.
 4,118,738. **QT KITCHENS AND DESIGN.** QUIKTRIP WEST, INC., MULTIPLE CLASS, (INT. CLS. 29 AND 30), (U.S. CL. 46). SN 85-461,218. PUB. 1-10-2012. FILED 11-1-2011.

CLASS 30—STAPLE FOODS

- 4,116,613. **HERRADURA . EST 1870 AGAVE NECTAR AND**

- DESIGN. BROWN-FORMAN CORPORATION**, (U.S. CL. 46). SN 77-736,964. PUB. 1-10-2012. FILED 5-14-2009.
- 4,116,638. **GARDEN VEGGIE MEDLEY (STANDARD CHARACTER)**. STACY'S PITA CHIP COMPANY, INC., (U.S. CL. 46). SN 77-859,302. PUB. 1-10-2012. FILED 10-28-2009.
- 4,116,645. **CHOCOLATE SANTANDER COLOMBIAN SINGLE ORIGIN NACIONAL DE CHOCOLATES AND DESIGN**. COMPAÑIA NACIONAL DE CHOCOLATES, S.A., (U.S. CL. 46). SN 77-880,654. PUB. 1-10-2012. FILED 11-25-2009.
- 4,116,694 (*See Class 29 for this trademark*).
- 4,116,704 (*See Class 1 for this trademark*).
- 4,116,785 (*See Class 29 for this trademark*).
- 4,116,803. **SAMBA (STANDARD CHARACTER)**. AUGUST STORCK KG, (U.S. CL. 46). SN 79-098,601. PUB. 1-10-2012. FILED 5-19-2011.
- 4,116,948. **HERB'S GARLIC (STANDARD CHARACTER)**. VIBRANT HEALTH PRODUCTS INC., DBA SILVER HILLS BAKERY, (U.S. CL. 46). SN 85-130,460. PUB. 1-10-2012. FILED 9-15-2010.
- 4,116,979. **MAXPAN HIGH SUGAR AND DESIGN**. PACIFIC FERMENTATION INDUSTRIES LTD, MULTIPLE CLASS, (INT. CLS. 30 AND 35), (U.S. CLS. 46, 100, 101 AND 102). SN 85-168,492. PUB. 1-10-2012. FILED 11-3-2010.
- 4,116,995. **VERO MANGO (STANDARD CHARACTER)**. GRUPO BIMBO S.A.B. DE C.V., (U.S. CL. 46). SN 85-187,786. PUB. 1-10-2012. FILED 11-30-2010.
- 4,117,017 (*See Class 29 for this trademark*).
- 4,117,031 (*See Class 29 for this trademark*).
- 4,117,074 (*See Class 25 for this trademark*).
- 4,117,138. **MARGARITEA (STANDARD CHARACTER)**. COMMEREX INTERNATIONAL LLC, (U.S. CL. 46). SN 85-232,711. PUB. 1-10-2012. FILED 2-2-2011.
- 4,117,149. **JAVA & CHA CO. BALANCE YOUR DAY... AND DESIGN**. COMMEREX INTERNATIONAL, (U.S. CL. 46). SN 85-233,840. PUB. 1-10-2012. FILED 2-3-2011.
- 4,117,217. **SUNNY PIZZA (STANDARD CHARACTER)**. MICHAEL COCHRANE, (U.S. CL. 46). SN 85-242,900. PUB. 1-10-2012. FILED 2-15-2011.
- 4,117,306. **MR. GREEN TEA (STANDARD CHARACTER)**. EMANUELE, RICHARD, (U.S. CL. 46). SN 85-261,351. PUB. 1-10-2012. FILED 3-8-2011.
- 4,117,308. **KASTLE KREAM DOUGHNUTS (STANDARD CHARACTER)**. KASTLE KREAM DOUGHNUTS CORP, TA KASTLE KREAM DOUGHNUTS, (U.S. CL. 46). SN 85-261,545. PUB. 1-10-2012. FILED 3-8-2011.
- 4,117,309. **CASTLE CREAM DOUGHNUTS (STANDARD CHARACTER)**. KASTLE KREAM DOUGHNUTS CORP, TA KASTLE CREAM DOUGHNUTS, (U.S. CL. 46). SN 85-261,566. PUB. 1-10-2012. FILED 3-8-2011.
- 4,117,338. **MALACHI TEA AND DESIGN**. JEFF WATTS, (U.S. CL. 46). SN 85-268,970. PUB. 1-10-2012. FILED 3-16-2011.
- 4,117,376. **NEW YORK BRAND AND DESIGN**. T. MARZETTI COMPANY, (U.S. CL. 46). SN 85-278,827. PUB. 1-10-2012. FILED 3-28-2011.
- 4,117,470. **FREED'S BAKERY (STANDARD CHARACTER)**. FREED'S BAKERY, LLC, (U.S. CL. 46). SN 85-295,627. PUB. 1-10-2012. FILED 4-14-2011.
- 4,117,477 (*See Class 25 for this trademark*).
- 4,117,482. **SISTERS' PANTRY (STANDARD CHARACTER)**. SISTERS' PANTRY, LLC, (U.S. CL. 46). SN 85-298,369. PUB. 1-10-2012. FILED 4-19-2011.
- 4,117,483. **SISTERS' PANTRY SP AND DESIGN**. SISTERS' PANTRY, LLC, (U.S. CL. 46). SN 85-298,380. PUB. 1-10-2012. FILED 4-19-2011.
- 4,117,486. **MAMI AND DESIGN**. PAN AMERICAN GRAIN MFG. CO., INC., (U.S. CL. 46). SN 85-298,985. PUB. 1-10-2012. FILED 4-19-2011.
- 4,117,522. **SUGAR IN THE RAW (STYLIZED)**. CUMBERLAND PACKING CORP., (U.S. CL. 46). SN 85-306,296. PUB. 1-10-2012. FILED 4-27-2011.
- 4,117,609. **PAN DI STELLE AND DESIGN**. BARILLA G. E. R. FRATELLI - SOCIETA' PER AZIONI, (U.S. CL. 46). SN 85-325,141. PUB. 1-10-2012. FILED 5-19-2011.
- 4,117,612. **Z TREATS (STANDARD CHARACTER)**. ZULLAS, L.C., DBA CAFE ZUPAS, (U.S. CL. 46). SN 85-325,385. PUB. 1-10-2012. FILED 5-19-2011.
- 4,117,623. **Z TREATS AND DESIGN**. ZULLAS, L.C., DBA CAFE ZUPAS, (U.S. CL. 46). SN 85-327,983. PUB. 1-10-2012. FILED 5-23-2011.
- 4,117,636 (*See Class 5 for this trademark*).
- 4,117,640. **SANDLER'S (STANDARD CHARACTER)**. SANDLER'S GIFT BASKETS OF DISTINCTION, INC., (U.S. CL. 46). SN 85-332,502. PUB. 1-10-2012. FILED 5-27-2011.
- 4,117,661. **WILD OPHELIA AND DESIGN**. VOSGES IP, LLC, (U.S. CL. 46). SN 85-335,681. PUB. 1-10-2012. FILED 6-1-2011.
- 4,117,670. **MOTHER MURPHY'S (STANDARD CHARACTER)**. MOTHER MURPHY'S LABORATORIES, INC., FORMERLY SOUTHERN LABORATORIES, INC., MULTIPLE CLASS, (INT. CLS. 30 AND 40), (U.S. CLS. 46, 100, 103 AND 106). SN 85-337,134. PUB. 1-10-2012. FILED 6-3-2011.
- 4,117,676. **DALE'S STEAK SEASONING AND DESIGN**. DALE'S SAUCES, INC., (U.S. CL. 46). SN 85-338,613. PUB. 1-10-2012. FILED 6-6-2011.
- 4,117,677. **DALE'S STEAK SEASONING (STANDARD CHARACTER)**. DALE'S SAUCES, INC., (U.S. CL. 46). SN 85-338,642. PUB. 1-10-2012. FILED 6-6-2011.
- 4,117,753. **YI MEI FUNG BAKERY CORP. SS AND DESIGN**. SO NEW YORK INC., (U.S. CL. 46). SN 85-351,902. PUB. 1-10-2012. FILED 6-21-2011.
- 4,117,814 (*See Class 29 for this trademark*).
- 4,117,817. **TREAT OF THE DAY! (STANDARD CHARACTER)**. JURA, CLIFTON P., DBA ADVANCED WHIZNOLOGY, (U.S. CL. 46). SN 85-360,136. PUB. 1-10-2012. FILED 6-30-2011.
- 4,117,831. **COME BUY AND DESIGN**. CHUANG PAY INTERNATIONAL CO., LTD., (U.S. CL. 46). SN 85-361,873. PUB. 11-29-2011. FILED 7-1-2011.
- 4,117,840. **TASTE LOVE CUPCAKES AND DESIGN**. RED VELVET CUPCAKES BY MICHELLE LLC, DBA TASTE LOVE CUPCAKES, (U.S. CL. 46). SN 85-363,071. PUB. 1-10-2012. FILED 7-5-2011.
- 4,117,924. **MITCHELL'S CHEESECAKES AND DESIGN**. SADOFF, MITCHELL, DBA MITCHELL'S CHEESECAKES, (U.S. CL. 46). SN 85-368,586. PUB. 1-10-2012. FILED 7-12-2011.
- 4,117,942. **POP CRAFT ALL NATURAL ARTISAN POPS AND DESIGN**. POP CRAFT, (U.S. CL. 46). SN 85-369,307. PUB. 1-10-2012. FILED 7-12-2011.
- 4,117,963. **MS. HAZEL'S TEA CAKES (STANDARD CHARACTER)**. WALKER, LONNIE, (U.S. CL. 46). SN 85-370,505. PUB. 1-10-2012. FILED 7-13-2011.
- 4,118,025. **NASTO'S OLD WORLD ICE CREAM (STANDARD CHARACTER)**. FRANK NASTO III, (U.S. CL. 46). SN 85-372,640. PUB. 1-10-2012. FILED 7-15-2011.
- 4,118,028. **NASTO'S OLD WORLD DESSERTS (STANDARD CHARACTER)**. FRANK NASTO III, (U.S. CL. 46). SN 85-372,673. PUB. 1-10-2012. FILED 7-15-2011.
- 4,118,036. **CARAMEL ADDICTION (STANDARD CHARACTER)**. SHERRY'S KITCHEN LLC, (U.S. CL. 46). SN 85-372,956. PUB. 1-10-2012. FILED 7-15-2011.
- 4,118,047. **FROYO NATION AND DESIGN**. WARREN AND MUNGRA LLC, DBA FROYO NATION AT BROADWAY COMMONS, (U.S. CL. 46). SN 85-373,171. PUB. 1-10-2012. FILED 7-16-2011.
- 4,118,063 (*See Class 25 for this trademark*).
- 4,118,095. **SERVE IT HEALTHY (STANDARD CHARACTER)**. SERVE IT HEALTHY FOODSERVICE COMPANY, (U.S. CL. 46). SN 85-374,275. PUB. 1-10-2012. FILED 7-18-2011.
- 4,118,109. **ESPRESSO SMITH AND DESIGN**. ESPRESSO SMITH INC., MULTIPLE CLASS, (INT. CLS. 30 AND 37), (U.S. CLS. 46, 100, 103 AND 106). SN 85-374,517. PUB. 1-10-2012. FILED 7-19-2011.
- 4,118,112 (*See Class 29 for this trademark*).
- 4,118,121. **CANDY FOR THE CAUSE (STANDARD CHARACTER)**. CANDYLAND BRANDS LLC, (U.S. CL. 46). SN 85-374,834. PUB. 1-10-2012. FILED 7-19-2011.
- 4,118,137. **ABBEY BRITTLE (STANDARD CHARACTER)**. SUBIACO ABBEY, (U.S. CL. 46). SN 85-375,251. PUB. 1-10-2012. FILED 7-19-2011.
- 4,118,139. **ABBEY BRITTLE AND DESIGN**. SUBIACO ABBEY, (U.S. CL. 46). SN 85-375,254. PUB. 1-10-2012. FILED 7-19-2011.
- 4,118,166. **TRINIDAD SIGNATURE COFFEE (STYLIZED)**. TRINIDAD COFFEE COMPANY, INC., (U.S. CL. 46). SN 85-375,549. PUB. 1-10-2012. FILED 7-19-2011.
- 4,118,229. **STEAK-EZE (STANDARD CHARACTER)**. ADVAN-

- CEPIERRE FOODS, INC., (U.S. CL. 46). SN 85-377,735. PUB. 1-10-2012. FILED 7-21-2011.
- 4,118,232. **STEEPED IN AMERICANA (STANDARD CHARACTER)**. BOHATCH, ROMAN, (U.S. CL. 46). SN 85-377,811. PUB. 1-10-2012. FILED 7-21-2011.
- 4,118,244. **TRUE GRAINS (STANDARD CHARACTER)**. ORLANDO BAKING COMPANY, INC., (U.S. CL. 46). SN 85-378,318. PUB. 1-10-2012. FILED 7-22-2011.
- 4,118,297. **SEED'LICIOUS (STANDARD CHARACTER)**. ORLANDO BAKING COMPANY, INC., (U.S. CL. 46). SN 85-381,974. PUB. 1-10-2012. FILED 7-27-2011.
- 4,118,389. **HOW HOT ARE YOU? (STANDARD CHARACTER)**. HABO CABO, INC., (U.S. CL. 46). SN 85-391,946. PUB. 1-10-2012. FILED 8-8-2011.
- 4,118,399. **YOCREAM (STANDARD CHARACTER)**. YOCREAM INTERNATIONAL, INC., MULTIPLE CLASS, (INT. CLS. 30, 32, 41 AND 43). (U.S. CLS. 45, 46, 48, 100, 101 AND 107). SN 85-392,207. PUB. 1-10-2012. FILED 8-8-2011.
- 4,118,416. **NÜCHA (STANDARD CHARACTER)**. D3 SITE INC., DBA NÜCHA, (U.S. CL. 46). SN 85-392,632. PUB. 1-10-2012. FILED 8-8-2011.
- 4,118,428. **TOUCAKE (STANDARD CHARACTER)**. TOUCAKE LLC, (U.S. CL. 46). SN 85-392,891. PUB. 1-10-2012. FILED 8-9-2011.
- 4,118,485. **SWEET SPOTS CREATIONS TANTALIZING, TEMPTING & TERRIFIC! AND DESIGN**. FOSTER-GOODMAN, SUSAN, (U.S. CL. 46). SN 85-393,854. PUB. 1-10-2012. FILED 8-9-2011.
- 4,118,490. **THE TEAOLOGIST AND DESIGN**. THE TEA LAB, LLC, (U.S. CL. 46). SN 85-393,973. PUB. 1-10-2012. FILED 8-10-2011.
- 4,118,495. **STOKES (STYLIZED)**. STOKES CANNING COMPANY, (U.S. CL. 46). SN 85-394,053. PUB. 1-10-2012. FILED 8-10-2011.
- 4,118,512. **LOCAL OVEN (STANDARD CHARACTER)**. BAKERYWORKS, L.L.C., (U.S. CL. 46). SN 85-394,480. PUB. 1-10-2012. FILED 8-10-2011.
- 4,118,514. **THERE'S NO GLUTEN . . . AND NO ONE KNOWS (STANDARD CHARACTER)**. BAKERYWORKS, L.L.C., (U.S. CL. 46). SN 85-394,511. PUB. 1-10-2012. FILED 8-10-2011.
- 4,118,516. **GOLDRUSH (STANDARD CHARACTER)**. HARRIS LIQUORS, INC., DBA HARRIS PIZZA, (U.S. CL. 46). SN 85-394,532. PUB. 1-10-2012. FILED 8-10-2011.
- 4,118,528. **G-BUCKS (STANDARD CHARACTER)**. PACIFIC REPUBLIC, INC., (U.S. CL. 46). SN 85-394,842. PUB. 1-10-2012. FILED 8-10-2011.
- 4,118,549 (*See Class 29 for this trademark*).
- 4,118,588. **HAMBURG-PICKLE-ON-TOP- MAKES YOUR HEART GO FLIPPITY-FLOP. (STANDARD CHARACTER)**. KEWPEE, INC., (U.S. CL. 46). SN 85-395,900. PUB. 1-10-2012. FILED 8-11-2011.
- 4,118,589. **BELCHEF (STANDARD CHARACTER)**. MARDALVI INTERNATIONAL USA, INC., (U.S. CL. 46). SN 85-395,917. PUB. 1-10-2012. FILED 8-11-2011.
- 4,118,607. **KERBEY LANE BAKERY AND DESIGN**. KERBEY LANE CAFE, INC., MULTIPLE CLASS, (INT. CLS. 30 AND 40). (U.S. CLS. 46, 100, 103 AND 106). SN 85-396,313. PUB. 1-10-2012. FILED 8-12-2011.
- 4,118,631. **ARISTA (STANDARD CHARACTER)**. TEC FOODS, INC., (U.S. CL. 46). SN 85-396,911. PUB. 1-10-2012. FILED 8-12-2011.
- 4,118,738 (*See Class 29 for this trademark*).

CLASS 31—NATURAL AGRICULTURAL PRODUCTS

- 4,116,704 (*See Class 1 for this trademark*).
- 4,116,824. **SILVERCALOS (STANDARD CHARACTER)**. JUNGPFANZEN GRÜNEWALD GMBH, (U.S. CLS. 1 AND 46). SN 79-100,072. PUB. 1-10-2012. FILED 6-27-2011.
- 4,116,967. **SNACK SWEETLY (STANDARD CHARACTER)**. MASTRONARDI PRODUCE LTD., (U.S. CLS. 1 AND 46). SN 85-151,804. PUB. 1-10-2012. FILED 10-13-2010.
- 4,116,990 (*See Class 29 for this trademark*).

- 4,117,331. **YVES PIAGET (STANDARD CHARACTER)**. MEILLAND INTERNATIONAL S.A., (U.S. CLS. 1 AND 46). SN 85-267,437. PUB. 1-10-2012. FILED 3-15-2011.
- 4,117,349. **LAVA (STANDARD CHARACTER)**. SCHIPPER & COMPANY U.S.A., INC., (U.S. CLS. 1 AND 46). SN 85-271,217. PUB. 1-10-2012. FILED 3-18-2011.
- 4,117,450. **OC RAW DOG AND DESIGN**. OC RAW DOG, LLC, (U.S. CLS. 1 AND 46). SN 85-293,059. PUB. 1-10-2012. FILED 4-12-2011.
- 4,117,560 (*See Class 25 for this trademark*).
- 4,117,561. **TANGO MULCH ORGANIC COMPOST (STANDARD CHARACTER)**. SOILAND CO., INC., (U.S. CLS. 1 AND 46). SN 85-316,959. PUB. 1-10-2012. FILED 5-10-2011.
- 4,117,578. **CATUNA (STANDARD CHARACTER)**. MING FONG YANG, (U.S. CLS. 1 AND 46). SN 85-320,817. PUB. 1-10-2012. FILED 5-13-2011.
- 4,117,714. **BELLAFINA (STANDARD CHARACTER)**. SEMINIS VEGETABLE SEEDS, INC., (U.S. CLS. 1 AND 46). SN 85-346,868. PUB. 1-10-2012. FILED 6-15-2011.
- 4,117,838. **AL DOLCE FICO (STANDARD CHARACTER)**. J & R DEBENEDETTO ORCHARDS, INC., (U.S. CLS. 1 AND 46). SN 85-363,016. PUB. 1-10-2012. FILED 7-5-2011.
- 4,117,998. **PERFECTLY NATURAL (STANDARD CHARACTER)**. HI-TEK RATIONS, INC., (U.S. CLS. 1 AND 46). SN 85-371,617. PUB. 1-10-2012. FILED 7-14-2011.
- 4,118,032. **ANGELCOT (STANDARD CHARACTER)**. SANBORN, MARJORIE L, (U.S. CLS. 1 AND 46). SN 85-372,838. PUB. 1-10-2012. FILED 7-15-2011.
- 4,118,213. **SPOOKY MOSS GARLAND (STANDARD CHARACTER)**. QUALITY GROWERS FLORAL COMPANY, INC., (U.S. CLS. 1 AND 46). SN 85-377,324. PUB. 1-10-2012. FILED 7-21-2011.
- 4,118,305. **HI-TEK RATIONS NATURALS (STANDARD CHARACTER)**. HI-TEK RATIONS, INC., (U.S. CLS. 1 AND 46). SN 85-383,514. PUB. 1-10-2012. FILED 7-28-2011.
- 4,118,509. **STICKYNOSE (STANDARD CHARACTER)**. CARLSON MORGAN LLC, (U.S. CLS. 1 AND 46). SN 85-394,393. PUB. 1-10-2012. FILED 8-10-2011.
- 4,118,577. **MISCELLANEOUS DESIGN**. COUNTRY BOY SEED, INC., (U.S. CLS. 1 AND 46). SN 85-395,770. PUB. 1-10-2012. FILED 8-11-2011.

CLASS 32—LIGHT BEVERAGES

- 4,116,771. **VIOLA (STYLIZED)**. MAURIZIO ARDUINI, (U.S. CLS. 45, 46 AND 48). SN 79-096,255. PUB. 1-10-2012. FILED 12-6-2010.
- 4,116,922. **ARTHUR'S DAY AND DESIGN**. DIAGEO IRELAND, (U.S. CLS. 45, 46 AND 48). SN 85-096,964. PUB. 1-10-2012. FILED 7-30-2010.
- 4,116,923. **ARTHUR GUINNESS DAY AND DESIGN**. DIAGEO IRELAND, (U.S. CLS. 45, 46 AND 48). SN 85-097,050. PUB. 1-10-2012. FILED 7-30-2010.
- 4,116,951 (*See Class 5 for this trademark*).
- 4,116,983 (*See Class 1 for this trademark*).
- 4,117,017 (*See Class 29 for this trademark*).
- 4,117,031 (*See Class 29 for this trademark*).
- 4,117,272 (*See Class 7 for this trademark*).
- 4,117,879. **FESTINA PECHE (STANDARD CHARACTER)**. DOGFISH HEAD MARKETING, LLC, (U.S. CLS. 45, 46 AND 48). SN 85-366,281. PUB. 1-10-2012. FILED 7-8-2011.
- 4,117,935. **MEXICANE (STANDARD CHARACTER)**. ALL NATURAL MAINE ROOT, LLC, (U.S. CLS. 45, 46 AND 48). SN 85-369,094. PUB. 1-10-2012. FILED 7-12-2011.
- 4,118,104. **HOP BARON (STANDARD CHARACTER)**. THE RIVERTOWN BREWING COMPANY, LLC, (U.S. CLS. 45, 46 AND 48). SN 85-374,398. PUB. 1-10-2012. FILED 7-18-2011.
- 4,118,222. **STASH IPA (STANDARD CHARACTER)**. INDEPENDENCE BREWING COMPANY, INC., (U.S. CLS. 45, 46 AND 48). SN 85-377,638. PUB. 1-10-2012. FILED 7-21-2011.
- 4,118,399 (*See Class 30 for this trademark*).
- 4,118,486 (*See Class 5 for this trademark*).
- 4,118,633. **WHIRLWIND (STANDARD CHARACTER)**. VICTORY BREWING COMPANY, (U.S. CLS. 45, 46 AND 48). SN 85-396,932. PUB. 1-10-2012. FILED 8-12-2011.
- 4,118,666 (*See Class 11 for this trademark*).

4,118,744 (*See Class 3 for this trademark.*)

CLASS 33—WINES AND SPIRITS

- 4,116,577. **MISCELLANEOUS DESIGN.** LEIGHT, JR., HOWARD S., (U.S. CLS. 47 AND 49). SN 76-708,060. PUB. 1-10-2012. FILED 6-20-2011.
- 4,116,578. **IZKALI (STYLIZED).** TRI-STARCO, INC., (U.S. CLS. 47 AND 49). SN 76-708,098. PUB. 1-10-2012. FILED 6-23-2011.
- 4,116,634. **ZELENAYA MARKA (STANDARD CHARACTER).** OBSHESTVO S OGRANICHENNOI OTVETSTVENNOSTIU "GLAVSPIRITTREST", (U.S. CLS. 47 AND 49). SN 77-833,940. PUB. 1-10-2012. FILED 9-24-2009.
- 4,116,639. **AVA MARIE'S DIVINITY (STANDARD CHARACTER).** GENDRON, MARK JAY, (U.S. CLS. 47 AND 49). SN 77-869,564. PUB. 7-27-2010. FILED 11-10-2009.
- 4,116,644. **JK ESTATES (STANDARD CHARACTER).** GENDRON, MARK J, (U.S. CLS. 47 AND 49). SN 77-878,165. PUB. 7-20-2010. FILED 11-21-2009.
- 4,116,646. **GREEN MARK GLAVSPIRITTREST AND DESIGN.** OBSHESTVO S OGRANICHENNOI OTVETSTVENNOSTIU "GLAVSPIRITTREST", (U.S. CLS. 47 AND 49). SN 77-882,628. PUB. 1-10-2012. FILED 11-30-2009.
- 4,116,677. **GRANDE VITAE (STANDARD CHARACTER).** GRANDE VITAE GMBH, (U.S. CLS. 47 AND 49). SN 79-065,496. PUB. 1-10-2012. FILED 12-9-2008.
- 4,116,695. **STOLICHNAYA STOLICHNAYA AND DESIGN.** SPIRITS INTERNATIONAL B.V., (U.S. CLS. 47 AND 49). SN 79-085,598. PUB. 1-10-2012. FILED 6-28-2010.
- 4,116,714. **VIA DEL CAMPO (STANDARD CHARACTER).** OENOFOROS AB, (U.S. CLS. 47 AND 49). SN 79-089,009. PUB. 1-10-2012. FILED 10-7-2010.
- 4,116,799. **MARCHESI ANTINORI 26 GENERAZIONI AND DESIGN.** MARCHESI ANTINORI S.R.L., (U.S. CLS. 47 AND 49). SN 79-098,101. PUB. 1-10-2012. FILED 4-13-2011.
- 4,116,800. **JAMBÚA (STANDARD CHARACTER).** JULIEN VAN DER VALK, H.O.D.N. GLOBAL SPIRIT COMPANY, (U.S. CLS. 47 AND 49). SN 79-098,170. PUB. 1-10-2012. FILED 5-17-2011.
- 4,116,830. **VODKA DIXON DIXON VODKA 40% 0.5 AND DESIGN.** OBSHESTVO S OGRANICHENNOY OTVETSTVENNOSTYU "SHUSHENSKAYA MARKA", (U.S. CLS. 47 AND 49). SN 79-100,502. PUB. 1-10-2012. FILED 5-18-2011.
- 4,116,864. **ARGIRIO (STANDARD CHARACTER).** PODERNUOVO S.R.L. SOCIETÀ AGRICOLA, (U.S. CLS. 47 AND 49). SN 79-103,227. PUB. 1-10-2012. FILED 8-9-2011.
- 4,116,883. **PAUA ROCK (STANDARD CHARACTER).** GOLDSCHMIDT VINEYARDS LLC, TA FIVE GOLD HANDS, (U.S. CLS. 47 AND 49). SN 85-018,400. PUB. 1-10-2012. FILED 4-20-2010.
- 4,117,402. **MOSCATO DAUSSIE (STANDARD CHARACTER).** ROYAL WINE CORPORATION, (U.S. CLS. 47 AND 49). SN 85-282,804. PUB. 1-10-2012. FILED 3-31-2011.
- 4,117,479. **ODDKA (STANDARD CHARACTER).** WYBOROWA S.A., (U.S. CLS. 47 AND 49). SN 85-297,890. PUB. 1-10-2012. FILED 4-18-2011.
- 4,117,508. **VALLE DE UCO MALBEC ROBLE FINCAS ADRIAN RIO SINGLE VINEYARD MENDOZA ARGENTINA AND DESIGN.** RIO, ADRIAN NORMAN, (U.S. CLS. 47 AND 49). SN 85-303,271. PUB. 1-10-2012. FILED 4-25-2011.
- 4,117,664. **0 DEGREES DRY RIESLING (STANDARD CHARACTER).** THREE BROTHERS WINERY & ESTATES LLC, (U.S. CLS. 47 AND 49). SN 85-335,908. PUB. 1-10-2012. FILED 6-2-2011.
- 4,117,665. **1ST DEGREE MEDIUM DRY RIESLING (STANDARD CHARACTER).** THREE BROTHERS WINERY & ESTATES LLC, (U.S. CLS. 47 AND 49). SN 85-335,910. PUB. 1-10-2012. FILED 6-2-2011.
- 4,117,667. **2ND DEGREE MEDIUM SWEET RIESLING (STANDARD CHARACTER).** THREE BROTHERS WINERY & ESTATES LLC, (U.S. CLS. 47 AND 49). SN 85-335,915. PUB. 1-10-2012. FILED 6-2-2011.
- 4,117,668. **3RD DEGREE LATE HARVEST SWEET RIESLING (STANDARD CHARACTER).** THREE BROTHERS WINERY & ESTATES LLC, (U.S. CLS. 47 AND 49). SN 85-

- 335,921. PUB. 1-10-2012. FILED 6-2-2011.
- 4,117,693. **NIKKA (STYLIZED).** THE NIKKA WHISKY DISTILLING CO., LTD., (U.S. CLS. 47 AND 49). SN 85-342,781. PUB. 1-10-2012. FILED 6-10-2011.
- 4,117,723. **VILLA CONCADORO (STANDARD CHARACTER).** "LA VIS S.C.A." IN SIGLA "L.V. S.C.A." - "C.S.L.S.S. S.C.A." "C.S.L. S.C.A." - "CANLAV S.C.A." - "CIELLE S.C.A.", (U.S. CLS. 47 AND 49). SN 85-348,206. PUB. 1-10-2012. FILED 6-16-2011.
- 4,117,724. **SANTO SANTO MOSCATO D'ASTI DENOMINAZIONE DI ORIGINE CONTROLLATA E GARANTITA ITALIA AND DESIGN.** ATLAS IMPORTS, L.L.C., (U.S. CLS. 47 AND 49). SN 85-348,390. PUB. 1-10-2012. FILED 6-16-2011.
- 4,117,904. **BALCONES RUMBLE (STANDARD CHARACTER).** BALCONES DISTILLING, LLC, (U.S. CLS. 47 AND 49). SN 85-367,328. PUB. 1-10-2012. FILED 7-9-2011.
- 4,118,090. **LABRASSEUR VINEYARD AND DESIGN.** LABRASSEUR WINERY LLC, DBA LABRASSEUR VINEYARD, (U.S. CLS. 47 AND 49). SN 85-374,224. PUB. 1-10-2012. FILED 7-18-2011.
- 4,118,261. **REGALIA (STANDARD CHARACTER).** AIKO IMPORTERS, INC., (U.S. CLS. 47 AND 49). SN 85-379,527. PUB. 1-10-2012. FILED 7-25-2011.
- 4,118,333. **FRITH (STANDARD CHARACTER).** LANE, CORY, (U.S. CLS. 47 AND 49). SN 85-388,412. PUB. 1-10-2012. FILED 8-3-2011.
- 4,118,359. **QUANTA (STANDARD CHARACTER).** THE EXECUTIVE ARENA, INC., (U.S. CLS. 47 AND 49). SN 85-390,075. PUB. 1-10-2012. FILED 8-4-2011.
- 4,118,493. **MULDERBOSCH (STANDARD CHARACTER).** BON VIEW TRADING 92 (PTY) LTD, (U.S. CLS. 47 AND 49). SN 85-394,014. PUB. 1-10-2012. FILED 8-10-2011.
- 4,118,494. **UNCLE DON'S (STANDARD CHARACTER).** OPICI IMPORT CO. INC., (U.S. CLS. 47 AND 49). SN 85-394,042. PUB. 1-10-2012. FILED 8-10-2011.
- 4,118,567. **MISCELLANEOUS DESIGN.** DA VE WINERY, INC., DBA SPIRAL WINES, (U.S. CLS. 47 AND 49). SN 85-395,684. PUB. 1-10-2012. FILED 8-11-2011.

CLASS 34—SMOKERS' ARTICLES

- 4,116,596. **MISCELLANEOUS DESIGN.** CIGARS INTERNATIONAL, INC., MULTIPLE CLASS, (INT. CLS. 34 AND 35), (U.S. CLS. 2, 8, 9, 17, 100, 101 AND 102). SN 77-371,152. PUB. 1-10-2012. FILED 1-14-2008.
- 4,116,617. **MISCELLANEOUS DESIGN.** SWEDISH MATCH NORTH EUROPE AB, (U.S. CLS. 2, 8, 9 AND 17). SN 77-763,053. PUB. 1-10-2012. FILED 6-18-2009.
- 4,116,618. **MISCELLANEOUS DESIGN.** SWEDISH MATCH NORTH EUROPE AB, (U.S. CLS. 2, 8, 9 AND 17). SN 77-763,084. PUB. 1-10-2012. FILED 6-18-2009.
- 4,116,619. **MISCELLANEOUS DESIGN.** SWEDISH MATCH NORTH EUROPE AB, (U.S. CLS. 2, 8, 9 AND 17). SN 77-763,101. PUB. 1-10-2012. FILED 6-18-2009.
- 4,116,757 (*See Class 9 for this trademark.*)
- 4,117,171. **VAPORZ E-CIGARETTE (STANDARD CHARACTER).** ZYMS DISTRIBUTION GROUP INC., (U.S. CLS. 2, 8, 9 AND 17). SN 85-236,269. PUB. 1-10-2012. FILED 2-8-2011.
- 4,117,184. **ALBINO RHINO (STANDARD CHARACTER).** INTERNATIONAL ODDITIES, INC., (U.S. CLS. 2, 8, 9 AND 17). SN 85-238,855. PUB. 6-21-2011. FILED 2-10-2011.
- 4,117,279. **AIR-FLOW (STANDARD CHARACTER).** FANTASIA DISTRIBUTION, INC., (U.S. CLS. 2, 8, 9 AND 17). SN 85-256,056. PUB. 1-10-2012. FILED 3-2-2011.
- 4,117,304. **MY FATHER S MF SPECIAL MF AND DESIGN.** MY FATHER CIGARS, INC., (U.S. CLS. 2, 8, 9 AND 17). SN 85-261,017. PUB. 1-10-2012. FILED 3-8-2011.
- 4,117,342. **CARBONELL (STANDARD CHARACTER).** TABACOS CARBONELL, S.A., (U.S. CLS. 2, 8, 9 AND 17). SN 85-269,678. PUB. 1-10-2012. FILED 3-17-2011.
- 4,117,820. **STRAIGHT UP (STANDARD CHARACTER).** NATIONAL TOBACCO COMPANY, L.P., (U.S. CLS. 2, 8, 9 AND 17). SN 85-360,321. PUB. 12-6-2011. FILED 6-30-2011.
- 4,117,977. **FLAVORMAX (STANDARD CHARACTER).** SIS RESOURCES LTD., (U.S. CLS. 2, 8, 9 AND 17). SN 85-

- 370,968. PUB. 1-10-2012. FILED 7-14-2011.
 4,118,021. **MARLBORO MIDNIGHT MENTHOL (STANDARD CHARACTER)**. PHILIP MORRIS USA INC., (U.S. CLS. 2, 8, 9 AND 17). SN 85-372,404. PUB. 1-10-2012. FILED 7-15-2011.
 4,118,247. **MANTELLA CIGARS M AND DESIGN**. GROSS, BEN, (U.S. CLS. 2, 8, 9 AND 17). SN 85-378,538. PUB. 1-10-2012. FILED 7-22-2011.
 4,118,299. **BRÖDERNA ANDERSSON (STANDARD CHARACTER)**. SKRUF SNUS AB, (U.S. CLS. 2, 8, 9 AND 17). SN 85-382,262. PUB. 1-10-2012. FILED 7-27-2011.
 4,118,735. **MISCELLANEOUS DESIGN**. TOP TOBACCO L.P., (U.S. CLS. 2, 8, 9 AND 17). SN 85-458,218. PUB. 1-10-2012. FILED 10-27-2011.

SERVICE MARKS

CLASS 35—ADVERTISING AND BUSINESS

- 4,116,554. **EROS (STANDARD CHARACTER)**. GROUP KAITU, LLC, (U.S. CLS. 100, 101 AND 102). SN 76-683,774. PUB. 1-10-2012. FILED 11-7-2007.
 4,116,555. **PINK CAKE BOX (STANDARD CHARACTER)**. PINK CAKE BOX LLC, (U.S. CLS. 100, 101 AND 102). SN 76-698,835. PUB. 1-10-2012. FILED 8-7-2009.
 4,116,560. **HUMERA (STANDARD CHARACTER)**. TCG, INC., (U.S. CLS. 100, 101 AND 102). SN 76-703,902. PUB. 1-11-2011. FILED 7-26-2010.
 4,116,571. **WE ARE BULLETPROOF AND DESIGN**. BULLETPROOF DESIGN LTD., MULTIPLE CLASS, (INT. CLS. 35 AND 42), (U.S. CLS. 100, 101 AND 102). SN 76-707,302. PUB. 10-4-2011. FILED 4-18-2011.
 4,116,572. **BULLETPROOF AND DESIGN**. BULLETPROOF DESIGN LTD., MULTIPLE CLASS, (INT. CLS. 35 AND 42), (U.S. CLS. 100, 101 AND 102). SN 76-707,303. PUB. 10-4-2011. FILED 4-18-2011.
 4,116,575. **OTM PARTNERS 2 WE LIVE AND BREATHE YOUR ISSUES AND DESIGN**. OTM PARTNERS LLC, (U.S. CLS. 100, 101 AND 102). SN 76-707,685. PUB. 1-10-2012. FILED 5-20-2011.
 4,116,576. **ALIGN MD (STANDARD CHARACTER)**. MARK GREEN, MULTIPLE CLASS, (INT. CLS. 35 AND 44), (U.S. CLS. 100, 101 AND 102). SN 76-708,016. PUB. 1-10-2012. FILED 6-16-2011.
 4,116,581. **ECO-SMART (STANDARD CHARACTER)**. SMARTPOOL, INC., (U.S. CLS. 100, 101 AND 102). SN 76-708,373. PUB. 1-10-2012. FILED 7-15-2011.
 4,116,582. **SMARTREPAIR (STANDARD CHARACTER)**. SMARTPOOL, INC., (U.S. CLS. 100, 101 AND 102). SN 76-708,376. PUB. 1-10-2012. FILED 7-15-2011.
 4,116,588. **TERRA AND DESIGN**. KOMPUGARD CORPORATION, (U.S. CLS. 100, 101 AND 102). SN 77-005,354. PUB. 1-10-2012. FILED 9-22-2006.
 4,116,589. **MEDIA TRUST (STANDARD CHARACTER)**. DCCO, LLC, MULTIPLE CLASS, (INT. CLS. 35 AND 39), (U.S. CLS. 100, 101, 102 AND 105). SN 77-113,344. PUB. 8-26-2008. FILED 2-22-2007.
 4,116,596 (*See Class 34 for this trademark*).
 4,116,605 (*See Class 9 for this trademark*).
 4,116,607. **IP CONCIERGE (STANDARD CHARACTER)**. UNITED COMMUNICATIONS SYSTEMS, INC., DBA CALL ONE, MULTIPLE CLASS, (INT. CLS. 35 AND 39), (U.S. CLS. 100, 101, 102 AND 105). SN 77-620,708. PUB. 1-10-2012. FILED 11-24-2008.
 4,116,612. **DIGIBEANZ (STANDARD CHARACTER)**. BUCKWOLD, BEN, MULTIPLE CLASS, (INT. CLS. 35, 38 AND 42), (U.S. CLS. 100, 101, 102 AND 104). SN 77-728,987. PUB. 1-10-2012. FILED 5-5-2009.
 4,116,614. **RAINMAKER (STANDARD CHARACTER)**. RAINMAKER SYSTEMS, INC., (U.S. CLS. 100, 101 AND 102). SN 77-739,863. PUB. 1-10-2012. FILED 5-19-2009.
 4,116,630. **SEO 1 (STANDARD CHARACTER)**. REDA YAMANI, (U.S. CLS. 100, 101 AND 102). SN 77-807,442. PUB. 1-10-2012. FILED 8-18-2009.
 4,116,647. **GROWTHLEADERS AND DESIGN**. GROWTHLEADERS, INC., MULTIPLE CLASS, (INT. CLS. 35 AND 41), (U.S. CLS. 100, 101, 102 AND 107). SN 77-901,828. PUB. 1-10-2012. FILED 12-28-2009.
 4,116,650 (*See Class 7 for this trademark*).
 4,116,651 (*See Class 7 for this trademark*).
 4,116,652 (*See Class 7 for this trademark*).
 4,116,653 (*See Class 7 for this trademark*).
 4,116,657. **DISCOVER MORE BY THE LAKESHORE! (STANDARD CHARACTER)**. WINCHESTER DOWNTOWN PROGRAM, (U.S. CLS. 100, 101 AND 102). SN 77-922,601. PUB. 1-10-2012. FILED 1-28-2010.
 4,116,664. **A CHARMED LIFE CHILD CARE, INC. AND DESIGN**. A CHARMED LIFE CHILDCARE, INC., DBA A CHARMED LIFE CHILDCARE, INC., (U.S. CLS. 100, 101 AND 102). SN 77-963,598. PUB. 1-10-2012. FILED 3-19-2010.
 4,116,678 (*See Class 1 for this trademark*).
 4,116,681 (*See Class 9 for this trademark*).
 4,116,690. **EATS & TWITTS AND DESIGN**. SOCIAL MEDIA EVENTS, S.L., MULTIPLE CLASS, (INT. CLS. 35 AND 41), (U.S. CLS. 100, 101, 102 AND 107). SN 79-083,339. PUB. 1-10-2012. FILED 5-7-2010.
 4,116,703 (*See Class 8 for this trademark*).
 4,116,705. **INNOVIA TECHNOLOGY (STYLIZED)**. INNOVIA TECHNOLOGY LIMITED, MULTIPLE CLASS, (INT. CLS. 35, 41, 42 AND 45), (U.S. CLS. 100, 101, 102 AND 107). SN 79-087,174. PUB. 1-10-2012. FILED 4-12-2010.
 4,116,710 (*See Class 16 for this trademark*).
 4,116,712 (*See Class 10 for this trademark*).
 4,116,718 (*See Class 10 for this trademark*).
 4,116,735 (*See Class 5 for this trademark*).
 4,116,759 (*See Class 9 for this trademark*).
 4,116,761 (*See Class 7 for this trademark*).
 4,116,775 (*See Class 9 for this trademark*).
 4,116,776. **MYOBIS (STANDARD CHARACTER)**. MYOBIS GMBH, MULTIPLE CLASS, (INT. CLS. 35, 36, 38, 39, 41 AND 43), (U.S. CLS. 100, 101, 102, 104, 105 AND 107). SN 79-096,468. PUB. 1-10-2012. FILED 2-16-2011.
 4,116,782 (*See Class 3 for this trademark*).
 4,116,785 (*See Class 29 for this trademark*).
 4,116,789 (*See Class 3 for this trademark*).
 4,116,801 (*See Class 9 for this trademark*).
 4,116,807. **INCOME AND DESIGN**. GERHARD H. WENGLORZ, (U.S. CLS. 100, 101 AND 102). SN 79-099,005. PUB. 1-10-2012. FILED 4-28-2011.
 4,116,809 (*See Class 6 for this trademark*).
 4,116,827 (*See Class 25 for this trademark*).
 4,116,829 (*See Class 6 for this trademark*).
 4,116,859. **IPMA DELTA (STANDARD CHARACTER)**. IPMA INTERNATIONAL PROJECT MANAGEMENT ASSOCIATION, MULTIPLE CLASS, (INT. CLS. 35 AND 42), (U.S. CLS. 100, 101 AND 102). SN 79-102,304. PUB. 1-10-2012. FILED 6-11-2011.
 4,116,878. **EVERY SHIP, EVERY TIME (STANDARD CHARACTER)**. EXACTEARTH LTD., MULTIPLE CLASS, (INT. CLS. 35, 38, 42 AND 45), (U.S. CLS. 100, 101, 102 AND 104). SN 85-008,725. PUB. 1-10-2012. FILED 4-7-2010.
 4,116,884 (*See Class 9 for this trademark*).
 4,116,895 (*See Class 9 for this trademark*).
 4,116,900. **POLK'S VEHICLE LAUNCH PROGRAM (STANDARD CHARACTER)**. R. L. POLK & CO., (U.S. CLS. 100, 101 AND 102). SN 85-070,427. PUB. 1-10-2012. FILED 6-24-2010.
 4,116,902. **PHONEZIP (STANDARD CHARACTER)**. PHONEZIP, INC., AKA PHONEZIP.COM, (U.S. CLS. 100, 101 AND 102). SN 85-072,348. PUB. 1-10-2012. FILED 6-26-2010.
 4,116,913. **PINNACLE HEALTH (STANDARD CHARACTER)**. PINNACLE HEALTH, INC., (U.S. CLS. 100, 101 AND 102). SN 85-087,574. PUB. 1-10-2012. FILED 7-19-2010.
 4,116,920. **THE BILL POLICE (STANDARD CHARACTER)**. THE BILL POLICE, INC., (U.S. CLS. 100, 101 AND 102). SN 85-094,829. PUB. 1-10-2012. FILED 7-28-2010.
 4,116,921 (*See Class 9 for this trademark*).
 4,116,933. **KIOKOM AND DESIGN**. KIOKOM, LLC, (U.S. CLS. 100, 101 AND 102). SN 85-109,791. PUB. 1-10-2012. FILED 8-17-2010.
 4,116,935. **ACTIVE CULTURE YOGURT + HEALTH BAR AND DESIGN**. VELVET YOGURT, INC., (U.S. CLS. 100, 101 AND 102). SN 85-113,564. PUB. 1-10-2012. FILED 8-23-2010.

- 4,116,938 (*See Class 25 for this trademark*).
- 4,116,941. **LEGAL QUEST SURVEYS FOR THE LAW AND DESIGN. ISSUES & ANSWERS NETWORK, INC.**, (U.S. CLS. 100, 101 AND 102). SN 85-121,023. PUB. 1-10-2012. FILED 9-1-2010.
- 4,116,944 (*See Class 14 for this trademark*).
- 4,116,945. **OUTSOURCEZINDIA AND DESIGN. FLATWORLD SOLUTIONS INC.**, MULTIPLE CLASS, (INT. CLS. 35 AND 42), (U.S. CLS. 100, 101 AND 102). SN 85-126,965. PUB. 1-10-2012. FILED 9-10-2010.
- 4,116,946. **FLATWORLD SOLUTIONS (STANDARD CHARACTER)**, FLATWORLD SOLUTIONS INC., MULTIPLE CLASS, (INT. CLS. 35, 40 AND 41), (U.S. CLS. 100, 101, 102, 103, 106 AND 107). SN 85-126,980. PUB. 1-10-2012. FILED 9-10-2010.
- 4,116,949. **SCHMOORU (STYLIZED)**, IB5K, LLC, MULTIPLE CLASS, (INT. CLS. 35 AND 41), (U.S. CLS. 100, 101, 102 AND 107). SN 85-130,703. PUB. 1-10-2012. FILED 9-15-2010.
- 4,116,954. **LINC SECUREFM (STANDARD CHARACTER)**, THE LINC GROUP, LLC, MULTIPLE CLASS, (INT. CLS. 35, 41 AND 45), (U.S. CLS. 100, 101, 102 AND 107). SN 85-133,684. PUB. 1-10-2012. FILED 9-20-2010.
- 4,116,955. **CHALLENGE AMERICA (STANDARD CHARACTER)**, CHALLENGE AMERICA, (U.S. CLS. 100, 101 AND 102). SN 85-134,547. PUB. 1-10-2012. FILED 9-21-2010.
- 4,116,977 (*See Class 25 for this trademark*).
- 4,116,978. **PANOVIA GROUP (STANDARD CHARACTER)**, PANOVIA GROUP LLP, MULTIPLE CLASS, (INT. CLS. 35 AND 45), (U.S. CLS. 100, 101 AND 102). SN 85-168,221. PUB. 1-10-2012. FILED 11-3-2010.
- 4,116,979 (*See Class 30 for this trademark*).
- 4,116,996. **GREEN RECYCLED PARTS AND DESIGN. AUTOMOTIVE RECYCLERS ASSOCIATION, AKA ARA**, MULTIPLE CLASS, (INT. CLS. 35 AND 42), (U.S. CLS. 100, 101 AND 102). SN 85-187,936. PUB. 1-10-2012. FILED 12-1-2010.
- 4,117,007. **WHERE AMERICA HAPPENED (STANDARD CHARACTER)**, THE JOURNEY THROUGH HALLOWED GROUND PARTNERSHIP, MULTIPLE CLASS, (INT. CLS. 35 AND 41), (U.S. CLS. 100, 101, 102 AND 107). SN 85-193,349. PUB. 1-10-2012. FILED 12-8-2010.
- 4,117,008. **TAKE THE JOURNEY (STANDARD CHARACTER)**, THE JOURNEY THROUGH HALLOWED GROUND PARTNERSHIP, MULTIPLE CLASS, (INT. CLS. 35 AND 41), (U.S. CLS. 100, 101, 102 AND 107). SN 85-193,379. PUB. 1-10-2012. FILED 12-8-2010.
- 4,117,015. **MORE POWER TO THE PLAYERS (STANDARD CHARACTER)**, GAMESTOP, INC., (U.S. CLS. 100, 101 AND 102). SN 85-197,800. PUB. 1-10-2012. FILED 12-14-2010.
- 4,117,030. **HRI (STANDARD CHARACTER)**, HEALTH RESEARCH, INCORPORATED, MULTIPLE CLASS, (INT. CLS. 35 AND 36), (U.S. CLS. 100, 101 AND 102). SN 85-204,645. PUB. 1-10-2012. FILED 12-23-2010.
- 4,117,039. **INFORMATION TECHNOLOGY FINANCIAL MANAGEMENT PROJECT MANAGEMENT ALEXTON MONITORING OF FINANCIAL MANAGEMENT SYSTEMS ACCOUNTING AND DESIGN**, ALEXTON INCORPORATED, MULTIPLE CLASS, (INT. CLS. 35, 36 AND 42), (U.S. CLS. 100, 101 AND 102). SN 85-209,325. PUB. 1-10-2012. FILED 1-3-2011.
- 4,117,042. **ADGA (STANDARD CHARACTER)**, FINANCIAL TIMES LIMITED, THE, MULTIPLE CLASS, (INT. CLS. 35, 38 AND 41), (U.S. CLS. 100, 101, 102, 104 AND 107). SN 85-210,985. PUB. 1-10-2012. FILED 1-5-2011.
- 4,117,054. **LOCK YOUR MEDS NFP AND DESIGN**, NATIONAL FAMILY PARTNERSHIP, (U.S. CLS. 100, 101 AND 102). SN 85-217,289. PUB. 1-10-2012. FILED 1-13-2011.
- 4,117,062. **PLOK WINE MERCHANTS AND DESIGN**, PLOK WINE MERCHANTS, LLC, (U.S. CLS. 100, 101 AND 102). SN 85-219,334. PUB. 1-10-2012. FILED 1-17-2011.
- 4,117,063. **KIAWAH ISLAND GOLF RESORT (STANDARD CHARACTER)**, KIAWAH ISLAND INN COMPANY, LLC, MULTIPLE CLASS, (INT. CLS. 35, 36, 39, 41, 43 AND 44), (U.S. CLS. 100, 101, 102, 105 AND 107). SN 85-219,925. PUB. 1-10-2012. FILED 1-18-2011.
- 4,117,077. **AMERICAN INSTITUTE OF CONSUMER STUDIES AND DESIGN**, LHK PARTNERS, INC., (U.S. CLS. 100, 101 AND 102). SN 85-222,191. PUB. 1-10-2012. FILED 1-20-2011.
- 4,117,078. **SOFTSQUATCH (STANDARD CHARACTER)**, SCHOLARBUYS LLC, MULTIPLE CLASS, (INT. CLS. 35 AND 41), (U.S. CLS. 100, 101, 102 AND 107). SN 85-222,586. PUB. 1-10-2012. FILED 1-20-2011.
- 4,117,082. **LIFE BRANDED (STANDARD CHARACTER)**, SMOAK, ANDREA V., MULTIPLE CLASS, (INT. CLS. 35 AND 45), (U.S. CLS. 100, 101 AND 102). SN 85-222,952. PUB. 1-10-2012. FILED 1-21-2011.
- 4,117,090 (*See Class 9 for this trademark*).
- 4,117,096. **H-PRIZE (STANDARD CHARACTER)**, UNITED STATES DEPARTMENT OF ENERGY, MULTIPLE CLASS, (INT. CLS. 35 AND 36), (U.S. CLS. 100, 101 AND 102). SN 85-225,697. PUB. 1-10-2012. FILED 1-25-2011.
- 4,117,099. **WESTERN ENERGY INSTITUTE (STANDARD CHARACTER)**, WESTERN ENERGY INSTITUTE, MULTIPLE CLASS, (INT. CLS. 35, 38, 40 AND 41), (U.S. CLS. 100, 101, 102, 103, 104, 106 AND 107). SN 85-225,808. PUB. 1-10-2012. FILED 1-25-2011.
- 4,117,101. **SOCIALLY OVERWHELMED (STANDARD CHARACTER)**, SOCIALLY OVERWHELMED, LLC, (U.S. CLS. 100, 101 AND 102). SN 85-226,027. PUB. 1-10-2012. FILED 1-25-2011.
- 4,117,105. **SOMOS OHANA NICARAGUA (STANDARD CHARACTER)**, SOMOS OHANA NICARAGUA, MULTIPLE CLASS, (INT. CLS. 35 AND 36), (U.S. CLS. 100, 101 AND 102). SN 85-226,913. PUB. 1-10-2012. FILED 1-26-2011.
- 4,117,106. **THE CLYMB (STANDARD CHARACTER)**, RETAIL INNOVATION GROUP INC., (U.S. CLS. 100, 101 AND 102). SN 85-227,155. PUB. 1-10-2012. FILED 1-26-2011.
- 4,117,110 (*See Class 25 for this trademark*).
- 4,117,118 (*See Class 25 for this trademark*).
- 4,117,119. **EASY REWARDS BY AMERICINN AND DESIGN**, AMERICINN INTERNATIONAL, LLC, (U.S. CLS. 100, 101 AND 102). SN 85-230,185. PUB. 1-10-2012. FILED 1-31-2011.
- 4,117,124. **ATTITUDES IN REVERSE (STANDARD CHARACTER)**, EVERYBODY LOVES KENNY PROJECT INC, MULTIPLE CLASS, (INT. CLS. 35, 36, 41 AND 45), (U.S. CLS. 100, 101, 102 AND 107). SN 85-230,893. PUB. 1-10-2012. FILED 2-1-2011.
- 4,117,128. **P PRIMERUS BUILT ON INTEGRITY. DRIVEN BY INNOVATION. AND DESIGN**, INTERNATIONAL SOCIETY OF PRIMERUS LAW FIRMS, LTD., THE, (U.S. CLS. 100, 101 AND 102). SN 85-231,355. PUB. 1-10-2012. FILED 2-1-2011.
- 4,117,135. **HALAL CUISINE ON AN ENLIGHTENED JOURNEY (STANDARD CHARACTER)**, AMERICAN HALAL COMPANY, INC., (U.S. CLS. 100, 101 AND 102). SN 85-232,468. PUB. 1-10-2012. FILED 2-2-2011.
- 4,117,152. **FOUNDERS ENTERTAINMENT (STANDARD CHARACTER)**, FOUNDERS ENTERTAINMENT, LLC, MULTIPLE CLASS, (INT. CLS. 35 AND 41), (U.S. CLS. 100, 101, 102 AND 107). SN 85-234,327. PUB. 1-10-2012. FILED 2-4-2011.
- 4,117,154. **FE FOUNDERS ENTERTAINMENT (STYLIZED)**, FOUNDERS ENTERTAINMENT, LLC, MULTIPLE CLASS, (INT. CLS. 35 AND 41), (U.S. CLS. 100, 101, 102 AND 107). SN 85-234,383. PUB. 1-10-2012. FILED 2-4-2011.
- 4,117,159. **DRIVE REWARDS AND DESIGN**, DEALER TIRE, LLC, (U.S. CLS. 100, 101 AND 102). SN 85-235,297. PUB. 1-10-2012. FILED 2-7-2011.
- 4,117,164. **THE BETTY MILLS COMPANY SNACK REWARDS AND DESIGN**, THE BETTY MILLS COMPANY, INC., (U.S. CLS. 100, 101 AND 102). SN 85-235,682. PUB. 1-10-2012. FILED 2-7-2011.
- 4,117,177. **GGA GREATER GOOD ALLIANCE (STYLIZED)**, GREENPROFIT SOLUTIONS, INC., (U.S. CLS. 100, 101 AND 102). SN 85-237,068. PUB. 1-10-2012. FILED 2-8-2011.
- 4,117,180. **THE PENCIL PARTNERSHIP PROGRAM (STANDARD CHARACTER)**, PENCIL, INC., MULTIPLE CLASS, (INT. CLS. 35 AND 36), (U.S. CLS. 100, 101 AND 102). SN 85-237,614. PUB. 1-10-2012. FILED 2-9-2011.
- 4,117,181. **PARTNERS FOR DEMOCRATIC CHANGE AND DESIGN**, PARTNERS FOR DEMOCRATIC CHANGE, (U.S. CLS. 100, 101 AND 102). SN 85-238,139. PUB. 1-10-2012. FILED 2-9-2011.
- 4,117,187. **ELEPHANT ENERGY (STANDARD CHARACTER)**, ELEPHANT ENERGY, INC., (U.S. CLS. 100, 101 AND 102). SN 85-238,992. PUB. 1-10-2012. FILED 2-10-2011.
- 4,117,190. **XYIENCE AND DESIGN**, MANZEN, LLC, (U.S.

- CLS. 100, 101 AND 102). SN 85-239,535. PUB. 1-10-2012. FILED 2-10-2011.
- 4,117,195. **MISCELLANEOUS DESIGN. PARTNERS FOR DEMOCRATIC CHANGE**, (U.S. CLS. 100, 101 AND 102). SN 85-240,337. PUB. 1-10-2012. FILED 2-11-2011.
- 4,117,196. **EXPERTISE ON CALL (STANDARD CHARACTER)**. RIVERWOOD SOLUTIONS LLC, (U.S. CLS. 100, 101 AND 102). SN 85-240,413. PUB. 1-10-2012. FILED 2-11-2011.
- 4,117,198 (*See Class 3 for this trademark*).
- 4,117,227. **RECALLADS.COM AND DESIGN. SERACU LTD., DBA RECALLADS.COM**, (U.S. CLS. 100, 101 AND 102). SN 85-245,616. PUB. 1-10-2012. FILED 2-18-2011.
- 4,117,233 (*See Class 9 for this trademark*).
- 4,117,240. **CONTINENTAL LUBE SUPPLY (STANDARD CHARACTER)**. DYK AUTOMOTIVE, LLC, (U.S. CLS. 100, 101 AND 102). SN 85-247,519. PUB. 1-10-2012. FILED 2-21-2011.
- 4,117,263. **CAMEO NOUVEAU (STYLIZED)**. CAMEO NOUVEAU, LLC, (U.S. CLS. 100, 101 AND 102). SN 85-252,458. PUB. 1-10-2012. FILED 2-26-2011.
- 4,117,265. **HONORING CHARACTER (STANDARD CHARACTER)**. NGUYEN, THANH D, MULTIPLE CLASS, (INT. CLS. 35, 36, 41 AND 42), (U.S. CLS. 100, 101, 102 AND 107). SN 85-252,539. PUB. 1-10-2012. FILED 2-26-2011.
- 4,117,266. **AUCTIONATA (STANDARD CHARACTER)**. ISA AUCTIONATA AUKTIONEN AG, MULTIPLE CLASS, (INT. CLS. 35, 42 AND 45), (U.S. CLS. 100, 101 AND 102). SN 85-252,749. PUB. 1-10-2012. FILED 2-27-2011.
- 4,117,267. **COLLABORATE MARKETPLACE (STANDARD CHARACTER)**. COLLINSON AND COMPANY, INC., MULTIPLE CLASS, (INT. CLS. 35 AND 39), (U.S. CLS. 100, 101, 102 AND 105). SN 85-253,637. PUB. 1-10-2012. FILED 2-28-2011.
- 4,117,269 (*See Class 9 for this trademark*).
- 4,117,271. **EAGLELIGHT (STANDARD CHARACTER)**. RAND-STEEL, LLC, (U.S. CLS. 100, 101 AND 102). SN 85-254,234. PUB. 1-10-2012. FILED 3-1-2011.
- 4,117,278. **CONSERVATION LAW FOUNDATION (STANDARD CHARACTER)**. CONSERVATION LAW FOUNDATION, INC., MULTIPLE CLASS, (INT. CLS. 35 AND 36), (U.S. CLS. 100, 101 AND 102). SN 85-256,032. PUB. 1-10-2012. FILED 3-2-2011.
- 4,117,289. **2ILEVERAGE MARKETING FIRM AND DESIGN**. WEBB, CHRISOLA, AND YANCEY, TAWAN, (U.S. CLS. 100, 101 AND 102). SN 85-259,030. PUB. 1-10-2012. FILED 3-5-2011.
- 4,117,311 (*See Class 25 for this trademark*).
- 4,117,322. **SMASH MARKETING AND DESIGN. SMASH MARKETING LLC**, (U.S. CLS. 100, 101 AND 102). SN 85-266,700. PUB. 1-10-2012. FILED 3-14-2011.
- 4,117,332. **PRIMA EYE GROUP (STANDARD CHARACTER)**. PRIMA EYE GROUP, INC., (U.S. CLS. 100, 101 AND 102). SN 85-267,622. PUB. 1-10-2012. FILED 3-15-2011.
- 4,117,333. **LENOX ADVISORS (STANDARD CHARACTER)**. LENOX ADVISORS, INC., MULTIPLE CLASS, (INT. CLS. 35, 36 AND 41), (U.S. CLS. 100, 101, 102 AND 107). SN 85-268,006. PUB. 1-10-2012. FILED 3-16-2011.
- 4,117,337. **REVERSE CUSTOMER SAVE PLAN (STANDARD CHARACTER)**. ACT II JEWELRY, LLC, (U.S. CLS. 100, 101 AND 102). SN 85-268,877. PUB. 1-10-2012. FILED 3-16-2011.
- 4,117,351. **IT'S A NOISY PLANET PROTECT THEIR HEARING AND DESIGN**. U.S. DEPARTMENT OF HEALTH AND HUMAN SERVICES, (U.S. CLS. 100, 101 AND 102). SN 85-271,915. PUB. 1-10-2012. FILED 3-21-2011.
- 4,117,354. **MAGENT (STANDARD CHARACTER)**. VANTAGE AGORA INC., MULTIPLE CLASS, (INT. CLS. 35, 36 AND 45), (U.S. CLS. 100, 101 AND 102). SN 85-272,465. PUB. 1-10-2012. FILED 3-21-2011.
- 4,117,356. **PETFOODDIRECT.COM (STANDARD CHARACTER)**. PET360, INC., MULTIPLE CLASS, (INT. CLS. 35 AND 39), (U.S. CLS. 100, 101, 102 AND 105). SN 85-273,234. PUB. 1-10-2012. FILED 3-22-2011.
- 4,117,364. **SAFARI - SALES ANALYTICS FOR ADVANCED REVENUE INSIGHT (STANDARD CHARACTER)**. SALES ANALYTICS, INC., (U.S. CLS. 100, 101 AND 102). SN 85-275,014. PUB. 1-10-2012. FILED S.R. 3-23-2011; AM. P.R. 6-21-2011.
- 4,117,368. **FLACK STEEL (STANDARD CHARACTER)**. FLACK, JEREMY, MULTIPLE CLASS, (INT. CLS. 35 AND 40), (U.S. CLS. 100, 101, 102, 103 AND 106). SN 85-275,981. PUB. 1-10-2012. FILED 3-24-2011.
- 4,117,370. **EYETRAFFIC MEDIA (STANDARD CHARACTER)**. PENTON MEDIA, INC., MULTIPLE CLASS, (INT. CLS. 35 AND 42), (U.S. CLS. 100, 101 AND 102). SN 85-277,398. PUB. 1-10-2012. FILED 3-25-2011.
- 4,117,372. **MORE THAN ENAF REFUND AND DESIGN**. DACOSTA FANE C., (U.S. CLS. 100, 101 AND 102). SN 85-277,712. PUB. 1-10-2012. FILED 3-25-2011.
- 4,117,382. **CYBER NIGHT OWLS (STANDARD CHARACTER)**. BELK STORES SERVICES, INC., (U.S. CLS. 100, 101 AND 102). SN 85-279,962. PUB. 1-10-2012. FILED 3-29-2011.
- 4,117,383. **BELK (STANDARD CHARACTER)**. BELK STORES SERVICES, INC., (U.S. CLS. 100, 101 AND 102). SN 85-279,973. PUB. 1-10-2012. FILED 3-29-2011.
- 4,117,384. **ACADIAN COMPANIES (STANDARD CHARACTER)**. ACADIAN AMBULANCE SERVICE, INC., MULTIPLE CLASS, (INT. CLS. 35, 39, 41, 44 AND 45), (U.S. CLS. 100, 101, 102, 105 AND 107). SN 85-280,104. PUB. 1-10-2012. FILED 3-29-2011.
- 4,117,387. **DETAG (STANDARD CHARACTER)**. HELPLINK CORPORATION, (U.S. CLS. 100, 101 AND 102). SN 85-280,519. PUB. 1-10-2012. FILED 3-29-2011.
- 4,117,392. **CONFITEXPO CONFECTIONERY TRADE SHOW AND DESIGN**. GRACIELA DIAZ SERRANO, (U.S. CLS. 100, 101 AND 102). SN 85-281,418. PUB. 1-10-2012. FILED 3-30-2011.
- 4,117,415. **ADDRESSLOGICS AND DESIGN. LIEBERTZ, ROBERT**, (U.S. CLS. 100, 101 AND 102). SN 85-286,027. PUB. 1-10-2012. FILED S.R. 4-5-2011; AM. P.R. 10-12-2011.
- 4,117,416. **NOVUS (STANDARD CHARACTER)**. NOVUS MEDIA, INC., (U.S. CLS. 100, 101 AND 102). SN 85-286,116. PUB. 1-10-2012. FILED 4-5-2011.
- 4,117,429. **PARK AVENUE COLLECTION (STANDARD CHARACTER)**. PARK AVENUE COLLECTION, LLC, (U.S. CLS. 100, 101 AND 102). SN 85-289,274. PUB. 1-10-2012. FILED 4-7-2011.
- 4,117,431. **FMYLIFE (STANDARD CHARACTER)**. OUCHE LORRAINE, (U.S. CLS. 100, 101 AND 102). SN 85-290,274. PUB. 1-10-2012. FILED 4-8-2011.
- 4,117,438. **DABBLERS (STANDARD CHARACTER)**. DABBLERS LLC, MULTIPLE CLASS, (INT. CLS. 35, 41 AND 43), (U.S. CLS. 100, 101, 102 AND 107). SN 85-291,462. PUB. 1-10-2012. FILED 4-11-2011.
- 4,117,452. **NATIONAL PREMIER SOCCER LEAGUE (STANDARD CHARACTER)**. NPSSL, INC., (U.S. CLS. 100, 101 AND 102). SN 85-293,220. PUB. 1-10-2012. FILED 4-12-2011.
- 4,117,453. **CATHOLIC SCHOOLS BELIEVE IT! (STANDARD CHARACTER)**. SPECIALTY FAMILY FOUNDATION, MULTIPLE CLASS, (INT. CLS. 35 AND 36), (U.S. CLS. 100, 101 AND 102). SN 85-293,314. PUB. 1-10-2012. FILED 4-12-2011.
- 4,117,468 (*See Class 25 for this trademark*).
- 4,117,471. **CITY OF MURPHY LIFE LIVED AT YOUR PACE AND DESIGN**. CITY OF MURPHY, TEXAS, (U.S. CLS. 100, 101 AND 102). SN 85-296,560. PUB. 1-10-2012. FILED 4-15-2011.
- 4,117,476. **SAILTIME (STANDARD CHARACTER)**. THE SAILTIME GROUP, LLC, MULTIPLE CLASS, (INT. CLS. 35, 36, 39 AND 41), (U.S. CLS. 100, 101, 102, 105 AND 107). SN 85-297,598. PUB. 1-10-2012. FILED 4-18-2011.
- 4,117,491 (*See Class 9 for this trademark*).
- 4,117,496 (*See Class 16 for this trademark*).
- 4,117,501. **RIGHT OF THE DOT AND DESIGN. RIGHT-OFTHEDOT, LLC, AKA RIGHT OF THE DOT**, MULTIPLE CLASS, (INT. CLS. 35 AND 36), (U.S. CLS. 100, 101 AND 102). SN 85-302,289. PUB. 1-10-2012. FILED 4-22-2011.
- 4,117,504. **CULINARY CREDENTIALS (STANDARD CHARACTER)**. OLSON COMMUNICATIONS INC., (U.S. CLS. 100, 101 AND 102). SN 85-302,543. PUB. 1-10-2012. FILED 4-22-2011.
- 4,117,512. **SOCIALEYEZ (STANDARD CHARACTER)**. SOCIALEYEZ FZE, MULTIPLE CLASS, (INT. CLS. 35 AND 42), (U.S. CLS. 100, 101 AND 102). SN 85-303,995. PUB. 1-10-2012. FILED 4-25-2011.
- 4,117,514. **RILEY WEISS (STANDARD CHARACTER)**. RILEY

- WEISS, INC., (U.S. CLS. 100, 101 AND 102). SN 85-304,166. PUB. 1-10-2012. FILED 4-25-2011.
- 4,117,516. **K KAYA TAX & BOOKKEEPING SERVICES, INC. AND DESIGN.** KAYA TAX & BOOKKEEPING SERVICES, INC., (U.S. CLS. 100, 101 AND 102). SN 85-304,362. PUB. 1-10-2012. FILED 4-25-2011.
- 4,117,517. **BIRTHDAY PALS (STANDARD CHARACTER).** CHARLOTTE D SUMRALL, DBA WELCOME HOST, (U.S. CLS. 100, 101 AND 102). SN 85-304,876. PUB. 1-10-2012. FILED 4-26-2011.
- 4,117,520. **FRONTIERFAN (STANDARD CHARACTER).** FRONTIER COMMUNICATIONS CORPORATION, (U.S. CLS. 100, 101 AND 102). SN 85-305,359. PUB. 1-10-2012. FILED 4-26-2011.
- 4,117,521. **III IPINION (STYLIZED).** IPINION LLC, (U.S. CLS. 100, 101 AND 102). SN 85-305,604. PUB. 1-10-2012. FILED 4-27-2011.
- 4,117,537. **WEBSOUT (STANDARD CHARACTER).** GREENO, LAURA, (U.S. CLS. 100, 101 AND 102). SN 85-310,441. PUB. 1-10-2012. FILED 5-2-2011.
- 4,117,539. **PERFECT IMPRINTS (STANDARD CHARACTER).** BLACK, PATRICK, (U.S. CLS. 100, 101 AND 102). SN 85-310,907. PUB. 1-10-2012. FILED 5-3-2011.
- 4,117,545. **WORKSPACE TECHNOLOGY AND DESIGN.** WORKSPACE TECHNOLOGY, INC., (U.S. CLS. 100, 101 AND 102). SN 85-312,506. PUB. 10-4-2011. FILED 5-4-2011.
- 4,117,552. **MARKETAMERICA.COM. BUILT ON PRODUCT. POWERED BY PEOPLE. AND DESIGN.** MARKET AMERICA, INC., (U.S. CLS. 100, 101 AND 102). SN 85-314,070. PUB. 1-10-2012. FILED 5-6-2011.
- 4,117,555 (*See Class 20 for this trademark.*).
- 4,117,559. **F THE FESTIVAL OF MEDIA AND DESIGN.** C SQUARED HOLDINGS LTD., MULTIPLE CLASS, (INT. CLS. 35 AND 41), (U.S. CLS. 100, 101, 102 AND 107). SN 85-315,805. PUB. 1-10-2012. FILED 5-9-2011.
- 4,117,562. **CARROLL COUNTY MARYLAND .1837. AND DESIGN.** COUNTY COMMISSIONERS OF CARROLL COUNTY, (U.S. CLS. 100, 101 AND 102). SN 85-317,664. PUB. 1-10-2012. FILED 5-11-2011.
- 4,117,572. **R RIDGWAY OUTDOORS AND DESIGN.** RIDGWAY OUTDOORS, INC., (U.S. CLS. 100, 101 AND 102). SN 85-319,748. PUB. 1-10-2012. FILED 5-12-2011.
- 4,117,594. **REMODELPRODUCTS.COM FOR ALL YOUR KITCHEN AND BATHROOM REMODELING NEEDS AND DESIGN.** HIGGINS AND LOVETT, (U.S. CLS. 100, 101 AND 102). SN 85-323,757. PUB. 1-10-2012. FILED 5-18-2011.
- 4,117,601. **GAY DAYS (STANDARD CHARACTER).** GAY DAYS, INC., (U.S. CLS. 100, 101 AND 102). SN 85-324,342. PUB. 1-10-2012. FILED 5-18-2011.
- 4,117,604. **REAL EXPERIENCES. REAL PEOPLE. (STANDARD CHARACTER).** MYAUTONETWORK, INC., (U.S. CLS. 100, 101 AND 102). SN 85-324,627. PUB. 1-10-2012. FILED 5-19-2011.
- 4,117,607. **ONSIGHT SOLUTIONS AND DESIGN.** ONSIGHT SOLUTIONS INTERNATIONAL, LLC, (U.S. CLS. 100, 101 AND 102). SN 85-325,116. PUB. 1-10-2012. FILED 5-19-2011.
- 4,117,610. **SERVICE PROCESS QUALITY MANAGEMENT SPQM AND DESIGN.** MTM SERVICES, (U.S. CLS. 100, 101 AND 102). SN 85-325,216. PUB. 1-10-2012. FILED 5-19-2011.
- 4,117,613. **TRIPINSURANCE.COM AND DESIGN.** ONLINE TRIP INSURANCE SERVICES, INC., MULTIPLE CLASS, (INT. CLS. 35, 36 AND 39), (U.S. CLS. 100, 101, 102 AND 105). SN 85-325,513. PUB. 1-10-2012. FILED 5-20-2011.
- 4,117,617. **CONCAVUS (STANDARD CHARACTER).** CONCAVUS INC., (U.S. CLS. 100, 101 AND 102). SN 85-326,553. PUB. 1-10-2012. FILED 5-20-2011.
- 4,117,624. **DCL DIRECT CONNECT LOGISTICS AND DESIGN.** EASTWOOD, TRACY, DBA VERAISON HOLDINGS, (U.S. CLS. 100, 101 AND 102). SN 85-328,015. PUB. 1-10-2012. FILED 5-23-2011.
- 4,117,637. **CHALLENGER DEVELOPMENT PROGRAM (STANDARD CHARACTER).** THE CORPORATE EXECUTIVE BOARD, INC., MULTIPLE CLASS, (INT. CLS. 35 AND 41), (U.S. CLS. 100, 101, 102 AND 107). SN 85-331,615. PUB. 1-10-2012. FILED 5-26-2011.
- 4,117,639. **THE WORLD'S CUSTOMIZATION ENGINE (STANDARD CHARACTER).** CAFEPRESS INC., MULTIPLE CLASS, (INT. CLS. 35 AND 40), (U.S. CLS. 100, 101, 102, 103 AND 106). SN 85-331,932. PUB. 1-10-2012. FILED 5-26-2011.
- 4,117,641. **SANDLER'S (STANDARD CHARACTER).** SANDLER'S GIFT BASKETS OF DISTINCTION, INC., (U.S. CLS. 100, 101 AND 102). SN 85-332,509. PUB. 1-10-2012. FILED 5-27-2011.
- 4,117,646. **BRAND AND SEND (STANDARD CHARACTER).** THE BASIS POINT, INC., (U.S. CLS. 100, 101 AND 102). SN 85-333,169. PUB. 1-10-2012. FILED 5-28-2011.
- 4,117,649. **NATIONAL SLEEP FOUNDATION (STANDARD CHARACTER).** NATIONAL SLEEP FOUNDATION, (U.S. CLS. 100, 101 AND 102). SN 85-333,589. PUB. 1-10-2012. FILED 5-31-2011.
- 4,117,650. **MISCELLANEOUS DESIGN.** HEART OF AMERICA E-COMMERCE, L.L.C., (U.S. CLS. 100, 101 AND 102). SN 85-333,612. PUB. 1-10-2012. FILED 5-31-2011.
- 4,117,662. **THE SIGN OF STELLAR SERVICE (STANDARD CHARACTER).** ORION ALLIED SERVICES LLC, MULTIPLE CLASS, (INT. CLS. 35 AND 44), (U.S. CLS. 100, 101 AND 102). SN 85-335,690. PUB. 1-10-2012. FILED 6-1-2011.
- 4,117,663. **TRI-MED PHARMACY (STANDARD CHARACTER).** ORION ALLIED SERVICES LLC, MULTIPLE CLASS, (INT. CLS. 35 AND 44), (U.S. CLS. 100, 101 AND 102). SN 85-335,693. PUB. 1-10-2012. FILED 6-1-2011.
- 4,117,666. **KENDALL (STANDARD CHARACTER).** KENDALL ELECTRIC, INC., (U.S. CLS. 100, 101 AND 102). SN 85-335,914. PUB. 1-10-2012. FILED 6-2-2011.
- 4,117,671. **CARNABYHOME (STANDARD CHARACTER).** CARNABY HOME, LLC, (U.S. CLS. 100, 101 AND 102). SN 85-337,228. PUB. 1-10-2012. FILED 6-3-2011.
- 4,117,674 (*See Class 14 for this trademark.*).
- 4,117,683. **HILLTOP BUTCHER SHOP (STANDARD CHARACTER).** HIGH COUNTRY INVESTOR, INC., (U.S. CLS. 100, 101 AND 102). SN 85-340,295. PUB. 1-10-2012. FILED 6-7-2011.
- 4,117,689. **AMERICAN RIFLE DEPOT (ARD) (STANDARD CHARACTER).** RICHARD FERRO, DBA AMERICAN RIFLE DEPOT (ARD), (U.S. CLS. 100, 101 AND 102). SN 85-341,929. PUB. 1-10-2012. FILED 6-9-2011.
- 4,117,695 (*See Class 25 for this trademark.*).
- 4,117,699. **DILEMMA X AND DESIGN.** DILEMMA X, (U.S. CLS. 100, 101 AND 102). SN 85-344,158. PUB. 1-10-2012. FILED 6-13-2011.
- 4,117,701. **FIGHT SUMMIT AND DESIGN.** H2 CONSULTING, INC., (U.S. CLS. 100, 101 AND 102). SN 85-344,458. PUB. 1-10-2012. FILED 6-13-2011.
- 4,117,707. **VILLAGE EXCHANGE (STANDARD CHARACTER).** PECHERSKY, MICHAEL, (U.S. CLS. 100, 101 AND 102). SN 85-345,409. PUB. 1-10-2012. FILED 6-14-2011.
- 4,117,711. **MISCELLANEOUS DESIGN.** NATIONAL ASSOCIATION OF PERSONAL FINANCIAL ADVISORS, INC., DBA NAPFA, (U.S. CLS. 100, 101 AND 102). SN 85-346,474. PUB. 1-10-2012. FILED 6-15-2011.
- 4,117,717. **ISE INSTITUTE FOR SCHOOL EXCELLENCE AND DESIGN.** INSTITUTE FOR SCHOOL EXCELLENCE, (U.S. CLS. 100, 101 AND 102). SN 85-347,209. PUB. 1-10-2012. FILED 6-15-2011.
- 4,117,720. **UNLIMITED JEANS (STANDARD CHARACTER).** UNLIMITED JEANS CO, INC., (U.S. CLS. 100, 101 AND 102). SN 85-347,531. PUB. 1-10-2012. FILED 6-16-2011.
- 4,117,727. **YAESTAMOS (STANDARD CHARACTER).** RAMOS-MATA, WILFRIDO, (U.S. CLS. 100, 101 AND 102). SN 85-349,008. PUB. 1-10-2012. FILED 6-17-2011.
- 4,117,739. **FYRESITE (STANDARD CHARACTER).** TURNQUIST ELSTINS TECHNOLOGY GROUP LLC, MULTIPLE CLASS, (INT. CLS. 35 AND 42), (U.S. CLS. 100, 101 AND 102). SN 85-350,660. PUB. 1-10-2012. FILED 6-20-2011.
- 4,117,745. **INTEREST NETWORKS (STANDARD CHARACTER).** INTEREST NETWORKS, LLC, MULTIPLE CLASS, (INT. CLS. 35 AND 41), (U.S. CLS. 100, 101, 102 AND 107). SN 85-351,329. PUB. 1-10-2012. FILED 6-21-2011.
- 4,117,760. **HOLLYWOOD MIRROR AND DESIGN.** OKUTANI CORPORATION, DBA HOLLYWOOD MIRROR, (U.S. CLS. 100, 101 AND 102). SN 85-352,771. PUB. 1-10-2012. FILED 6-22-2011.
- 4,117,761. **SIMPLE PLAY SPPNOLA.COM AND DESIGN.** RICHARD, RON, (U.S. CLS. 100, 101 AND 102). SN 85-

- 352,794. PUB. 1-10-2012. FILED 6-22-2011.
- 4,117,766. **N2 AND DESIGN. IN2VATE, L.L.C., MULTIPLE CLASS, (INT. CLS. 35, 41, 42 AND 45), (U.S. CLS. 100, 101, 102 AND 107), SN 85-353,807. PUB. 1-10-2012. FILED 6-23-2011.**
- 4,117,781. **DARKHORSE GEOSPATIAL (STANDARD CHARACTER), DARKHORSE GEOSPATIAL LLC, (U.S. CLS. 100, 101 AND 102), SN 85-355,785. PUB. 1-10-2012. FILED 6-24-2011.**
- 4,117,782. **E EYE TOUR AND DESIGN, GUIDE-POD, INC., MULTIPLE CLASS, (INT. CLS. 35 AND 39), (U.S. CLS. 100, 101, 102 AND 105), SN 85-356,111. PUB. 1-10-2012. FILED 6-24-2011.**
- 4,117,783. **MEDIAGAZER (STANDARD CHARACTER), EPIVOZ CORPORATION, MULTIPLE CLASS, (INT. CLS. 35 AND 41), (U.S. CLS. 100, 101, 102 AND 107), SN 85-356,211. PUB. 1-10-2012. FILED 6-25-2011.**
- 4,117,784. **SOHOBOGO (STANDARD CHARACTER), SOHOBOGO ENTERPRISE, LLC, AKA SOHOBOGO OR SOHOBOGO.COM, AND ASTA, MATTHEW A., (U.S. CLS. 100, 101 AND 102), SN 85-356,315. PUB. 1-10-2012. FILED 6-25-2011.**
- 4,117,789. **U2 UNIQUESQUARED BE U. BE UNIQUE. AND DESIGN, UNIQUE SQUARED INC., (U.S. CLS. 100, 101 AND 102), SN 85-356,436. PUB. 1-10-2012. FILED 6-26-2011.**
- 4,117,797. **POWM (STANDARD CHARACTER), PHYSICIANS' ORGANIZATION OF WESTERN MICHIGAN, INC., (U.S. CLS. 100, 101 AND 102), SN 85-358,094. PUB. 1-10-2012. FILED 6-28-2011.**
- 4,117,801. **OCEAN FRIENDLY GARDENS AND DESIGN, SURFRIDER FOUNDATION, (U.S. CLS. 100, 101 AND 102), SN 85-358,816. PUB. 1-10-2012. FILED 6-28-2011.**
- 4,117,805. **BAMB ECOLOGICAL TECHNOLOGY AND DESIGN, BAMB ECOLOGICAL TECHNOLOGY, INC., (U.S. CLS. 100, 101 AND 102), SN 85-359,015. PUB. 1-10-2012. FILED 6-29-2011.**
- 4,117,815. **GG AND DESIGN, WILSON, JULIA A., (U.S. CLS. 100, 101 AND 102), SN 85-359,760. PUB. 1-10-2012. FILED 6-29-2011.**
- 4,117,816. **PROTOCOLS (STANDARD CHARACTER), ALLOCATION SERVICES, INC., MULTIPLE CLASS, (INT. CLS. 35 AND 36), (U.S. CLS. 100, 101 AND 102), SN 85-359,798. PUB. 1-10-2012. FILED 6-29-2011.**
- 4,117,824. **GHS GLOBAL HUNTER SECURITIES AND DESIGN, GLOBAL HUNTER SECURITIES, LLC, MULTIPLE CLASS, (INT. CLS. 35 AND 36), (U.S. CLS. 100, 101 AND 102), SN 85-360,640. PUB. 1-10-2012. FILED 6-30-2011.**
- 4,117,826. **UNION SQUARE AND DESIGN, UNION SQUARE BUSINESS IMPROVEMENT DISTRICT, INC., (U.S. CLS. 100, 101 AND 102), SN 85-360,915. PUB. 1-10-2012. FILED 6-30-2011.**
- 4,117,830. **G@ME (STANDARD CHARACTER), KOZEL, JENNIFER, AND HARRER, PAUL A., (U.S. CLS. 100, 101 AND 102), SN 85-361,300. PUB. 1-10-2012. FILED 6-30-2011.**
- 4,117,833. **TALKING SEX (STANDARD CHARACTER), CASTLE MEDIA GROUP, INC., MULTIPLE CLASS, (INT. CLS. 35 AND 41), (U.S. CLS. 100, 101, 102 AND 107), SN 85-362,207. PUB. 1-10-2012. FILED 7-1-2011.**
- 4,117,845. **THE ATUM GROUP COLLABORATE . DELIVER . ACHIEVE AND DESIGN, THE ATUM GROUP, LLC, DBA THE ATUM GROUP, (U.S. CLS. 100, 101 AND 102), SN 85-364,179. PUB. 1-10-2012. FILED 7-6-2011.**
- 4,117,848. **GS GREENSHOPS AND DESIGN, GREENSHOPS.-COM INC, (U.S. CLS. 100, 101 AND 102), SN 85-364,309. PUB. 1-10-2012. FILED 7-6-2011.**
- 4,117,849. **FRIEND.VU (STANDARD CHARACTER), JOSEPH MILLER, MULTIPLE CLASS, (INT. CLS. 35 AND 45), (U.S. CLS. 100, 101 AND 102), SN 85-364,316. PUB. 1-10-2012. FILED 7-6-2011.**
- 4,117,850. **OFF CAMPUS MEDIA (STANDARD CHARACTER), MOVING OFF CAMPUS, (U.S. CLS. 100, 101 AND 102), SN 85-364,403. PUB. 1-10-2012. FILED 7-6-2011.**
- 4,117,851. **CREDIT UNION EXPRESS (STANDARD CHARACTER), BILLARD, CHARLES, (U.S. CLS. 100, 101 AND 102), SN 85-364,469. PUB. 1-10-2012. FILED 7-6-2011.**
- 4,117,859. **SHAPE MATIC AND DESIGN, STARSKYMATIC, INC., MULTIPLE CLASS, (INT. CLS. 35 AND 38), (U.S. CLS. 100, 101, 102 AND 104), SN 85-364,956. PUB. 1-10-2012. FILED 7-7-2011.**
- 4,117,863 (*See Class 25 for this trademark*).
- 4,117,869. **SKY SILVER (STANDARD CHARACTER), FIST PRODUCTIONS LTD., (U.S. CLS. 100, 101 AND 102), SN 85-365,493. PUB. 1-10-2012. FILED 7-7-2011.**
- 4,117,873. **RANDOM ACTS OF PIZZA (STANDARD CHARACTER), ROGERS, DANIEL A., MULTIPLE CLASS, (INT. CLS. 35 AND 42), (U.S. CLS. 100, 101 AND 102), SN 85-365,765. PUB. 1-10-2012. FILED 7-7-2011.**
- 4,117,874. **SAVING CENTS WITH SENSE (STANDARD CHARACTER), SAVING SENSE MEDIA, LLC, MULTIPLE CLASS, (INT. CLS. 35 AND 36), (U.S. CLS. 100, 101 AND 102), SN 85-365,889. PUB. 1-10-2012. FILED 7-7-2011.**
- 4,117,877. **JOSEPH-BETH BOOKSELLERS (STANDARD CHARACTER), BOOKSELLERS ENTERPRISES, LLC, (U.S. CLS. 100, 101 AND 102), SN 85-366,173. PUB. 1-10-2012. FILED 7-8-2011.**
- 4,117,884. **SCOREMORE (STANDARD CHARACTER), GUTTFREUND, SASCHA, MULTIPLE CLASS, (INT. CLS. 35 AND 41), (U.S. CLS. 100, 101, 102 AND 107), SN 85-366,368. PUB. 1-10-2012. FILED 7-8-2011.**
- 4,117,885. **JHC RISK STRATEGIES, LLC AND DESIGN, JHC RISK STRATEGIES, LLC, (U.S. CLS. 100, 101 AND 102), SN 85-366,390. PUB. 1-10-2012. FILED 7-8-2011.**
- 4,117,886. **THE PIANO GUYS (STANDARD CHARACTER), PT MANAGEMENT, INC., (U.S. CLS. 100, 101 AND 102), SN 85-366,416. PUB. 1-10-2012. FILED 7-8-2011.**
- 4,117,891. **JR JORDAN RIVER MOVING & STORAGE NESW AND DESIGN, JORDAN RIVER MOVING L.L.C., (U.S. CLS. 100, 101 AND 102), SN 85-366,723. PUB. 1-10-2012. FILED 7-8-2011.**
- 4,117,892. **INSITE INTERACTIVE (STANDARD CHARACTER), INSITE PRODUCTIONS, LLC, DBA INSITE INTERACTIVE, MULTIPLE CLASS, (INT. CLS. 35 AND 42), (U.S. CLS. 100, 101 AND 102), SN 85-366,734. PUB. 1-10-2012. FILED 7-8-2011.**
- 4,117,893. **CHC AND DESIGN, CHILDREN HELPING CHILDREN, INC., (U.S. CLS. 100, 101 AND 102), SN 85-366,765. PUB. 1-10-2012. FILED 7-8-2011.**
- 4,117,898. **REDSKY MOBILITY SOLUTIONS AND DESIGN, REDSKY MOBILITY SOLUTIONS, LLC, MULTIPLE CLASS, (INT. CLS. 35 AND 42), (U.S. CLS. 100, 101 AND 102), SN 85-367,108. PUB. 1-10-2012. FILED 7-8-2011.**
- 4,117,903. **BORDERLESS CULTURE (STANDARD CHARACTER), HAIDER, DEEBA, MULTIPLE CLASS, (INT. CLS. 35 AND 41), (U.S. CLS. 100, 101, 102 AND 107), SN 85-367,294. PUB. 1-10-2012. FILED 7-9-2011.**
- 4,117,918. **JOSEPH-BETH (STANDARD CHARACTER), BOOKSELLERS ENTERPRISES, LLC, (U.S. CLS. 100, 101 AND 102), SN 85-368,368. PUB. 1-10-2012. FILED 7-11-2011.**
- 4,117,922. **SOETANTO AND DESIGN, REGINALD ABRAHAM SOETANTO, MULTIPLE CLASS, (INT. CLS. 35, 37 AND 42), (U.S. CLS. 100, 101, 102, 103 AND 106), SN 85-368,544. PUB. 1-10-2012. FILED 7-11-2011.**
- 4,117,923. **FLIP 'N DIP FROZEN YOGURT SELF SERVE AND DESIGN, FLIP 'N DIP, (U.S. CLS. 100, 101 AND 102), SN 85-368,568. PUB. 1-10-2012. FILED 7-12-2011.**
- 4,117,927. **KOKORO & MOI (STYLIZED), KOKORO & MOI OY, (U.S. CLS. 100, 101 AND 102), SN 85-368,873. PUB. 1-10-2012. FILED 7-12-2011.**
- 4,117,928. **H&S PERFORMANCE AND DESIGN, H&S PERFORMANCE, (U.S. CLS. 100, 101 AND 102), SN 85-368,876. PUB. 1-10-2012. FILED 7-12-2011.**
- 4,117,938. **SMART GRID SPEAK AND DESIGN, SMART GRID SPEAK LLC, (U.S. CLS. 100, 101 AND 102), SN 85-369,240. PUB. 1-10-2012. FILED 7-12-2011.**
- 4,117,941. **IDC COIN & BULLION (STANDARD CHARACTER), K.M.A. SUNBELT TRADING CORPORATION, (U.S. CLS. 100, 101 AND 102), SN 85-369,306. PUB. 1-10-2012. FILED 7-12-2011.**
- 4,117,943. **MINDPEACE (STANDARD CHARACTER), MINDPEACE CINCINNATI, INC., (U.S. CLS. 100, 101 AND 102), SN 85-369,331. PUB. 1-10-2012. FILED 7-12-2011.**
- 4,117,947. **SAN FRANCIS IMPORTS (STANDARD CHARACTER), SAN FRANCIS IMPORTS, INC., (U.S. CLS. 100, 101 AND 102), SN 85-369,519. PUB. 1-10-2012. FILED 7-12-2011.**
- 4,117,950. **THE ITEM SHOPPE (STANDARD CHARACTER), URBANSKI, MICHAEL C., (U.S. CLS. 100, 101 AND 102),**

- SN 85-369,724. PUB. 1-10-2012. FILED 7-12-2011.
- 4,117,951. **ADVOMAS (STANDARD CHARACTER)**. HOSPI-HELP, INC., MULTIPLE CLASS, (INT. CLS. 35 AND 36), (U.S. CLS. 100, 101 AND 102). SN 85-369,755. PUB. 1-10-2012. FILED 7-12-2011.
- 4,117,972. **HOME ANALYZERS CONFIDENCE BEFORE THE CLOSING. AND DESIGN.** HOME ANALYZERS DEVELOPMENT COMPANY LLC, (U.S. CLS. 100, 101 AND 102). SN 85-370,764. PUB. 1-10-2012. FILED 7-13-2011.
- 4,117,983. **CLLA (STANDARD CHARACTER)**. COMMERCIAL LAW LEAGUE OF AMERICA, (U.S. CLS. 100, 101 AND 102). SN 85-371,092. PUB. 1-10-2012. FILED 7-14-2011.
- 4,117,984. **REACT TO FILM AND DESIGN.** REACT TO FILM INC., MULTIPLE CLASS, (INT. CLS. 35 AND 41), (U.S. CLS. 100, 101, 102 AND 107). SN 85-371,107. PUB. 1-10-2012. FILED 7-14-2011.
- 4,117,986. **SERVICE IS THE DIFFERENCE. WE GET IT! AND DESIGN.** AFTERMARKET AUTO PARTS ALLIANCE, INC., MULTIPLE CLASS, (INT. CLS. 35 AND 37), (U.S. CLS. 100, 101, 102, 103 AND 106). SN 85-371,228. PUB. 1-10-2012. FILED 7-14-2011.
- 4,117,990. **PLAN PACK STORE MOVE (STANDARD CHARACTER)**. THE SUDDATH COMPANIES, MULTIPLE CLASS, (INT. CLS. 35, 36 AND 39), (U.S. CLS. 100, 101, 102 AND 105). SN 85-371,292. PUB. 1-10-2012. FILED 7-14-2011.
- 4,117,995. **OGSYSTEMS AND DESIGN.** PAGON, GARRETT D., AND BALKISSOON, OMAR, (U.S. CLS. 100, 101 AND 102). SN 85-371,465. PUB. 1-10-2012. FILED 7-14-2011.
- 4,118,001. **BEREAN CHRISTIAN STORES THE WORLD (STYLIZED)**. BEREAN CHRISTIAN STORES ENDEAVOR, LLC, MULTIPLE CLASS, (INT. CLS. 35 AND 36), (U.S. CLS. 100, 101 AND 102). SN 85-371,844. PUB. 1-10-2012. FILED 7-14-2011.
- 4,118,007. **EVERYNEIGHBORHOOD PARTNERSHIP (STANDARD CHARACTER)**. EVERY NEIGHBORHOOD PARTNERSHIP, (U.S. CLS. 100, 101 AND 102). SN 85-372,035. PUB. 1-10-2012. FILED 7-15-2011.
- 4,118,010. **MRI CONTRACT STAFFING (STANDARD CHARACTER)**. BROWNS CANYON CORPORATION, (U.S. CLS. 100, 101 AND 102). SN 85-372,113. PUB. 1-10-2012. FILED 7-15-2011.
- 4,118,011. **FEARLESS MEDIA LLC AND DESIGN.** FEARLESS MEDIA, LLC, (U.S. CLS. 100, 101 AND 102). SN 85-372,178. PUB. 1-10-2012. FILED 7-15-2011.
- 4,118,016. **CARDAGIN (STANDARD CHARACTER)**. CARDAGIN NETWORKS, INC., (U.S. CLS. 100, 101 AND 102). SN 85-372,306. PUB. 1-10-2012. FILED 7-15-2011.
- 4,118,019. **AMELIA ISLAND AND DESIGN.** THE COUNTY OF NASSAU, (U.S. CLS. 100, 101 AND 102). SN 85-372,356. PUB. 1-10-2012. FILED 7-15-2011.
- 4,118,022. **LATINO COMP A LATINA/O ASSOCIATION OF WORKERS' COMPENSATION PROFESSIONALS AND DESIGN.** LATINO COMP, MULTIPLE CLASS, (INT. CLS. 35 AND 36), (U.S. CLS. 100, 101 AND 102). SN 85-372,419. PUB. 1-10-2012. FILED 7-15-2011.
- 4,118,024. **SMOKIN' JOKERS AND DESIGN.** SMOKIN JOKERS, (U.S. CLS. 100, 101 AND 102). SN 85-372,572. PUB. 1-10-2012. FILED 7-15-2011.
- 4,118,026. **THE RECLAIM GROUP AND DESIGN.** THE RECLAIM GROUP, LLC, (U.S. CLS. 100, 101 AND 102). SN 85-372,647. PUB. 1-10-2012. FILED 7-15-2011.
- 4,118,035. **MIDDLE PATH MEDICINE (STANDARD CHARACTER)**. MIDDLE PATH MEDICINE, (U.S. CLS. 100, 101 AND 102). SN 85-372,949. PUB. 1-10-2012. FILED 7-15-2011.
- 4,118,042. **TRAVELING CHIC BOUTIQUE (STANDARD CHARACTER)**. TRAVELING CHIC BOUTIQUE, LLC, (U.S. CLS. 100, 101 AND 102). SN 85-373,088. PUB. 1-10-2012. FILED 7-16-2011.
- 4,118,049. **CHALLENGER & TRUSS PRODUCTIONS AND DESIGN.** CHALLENGER & TRUSS PRODUCTIONS, (U.S. CLS. 100, 101 AND 102). SN 85-373,339. PUB. 1-10-2012. FILED 7-17-2011.
- 4,118,056. **#HURT (STANDARD CHARACTER)**. FOUR CORNERS MOBILE MEDIA, LLC, (U.S. CLS. 100, 101 AND 102). SN 85-373,557. PUB. 1-10-2012. FILED S.R. 7-18-2011; AM. P.R. 11-15-2011.
- 4,118,060. **ADVOCATING QUALITY HEALTHCARE WITH PROFESSIONAL EXCELLENCE, INTEGRITY, AND PAS- SION. (STANDARD CHARACTER)**. MEDICAL LEGAL NURSE CONSULTANTS, LLC, (U.S. CLS. 100, 101 AND 102). SN 85-373,615. PUB. 1-10-2012. FILED 7-18-2011.
- 4,118,071. **TICKETS NOT TOASTERS (STANDARD CHARACTER)**. WEDDING TICKET REGISTRY, (U.S. CLS. 100, 101 AND 102). SN 85-373,776. PUB. 1-10-2012. FILED 7-18-2011.
- 4,118,081. **IF IT'S HALLOWEEN (STANDARD CHARACTER)**. SEASONAL WHOLESALE LLC, (U.S. CLS. 100, 101 AND 102). SN 85-373,987. PUB. 1-10-2012. FILED 7-18-2011.
- 4,118,087. **CAREER FOX (STANDARD CHARACTER)**. COR-DRAY, JULIA, (U.S. CLS. 100, 101 AND 102). SN 85-374,191. PUB. 1-10-2012. FILED 7-18-2011.
- 4,118,089. **THE KRAZY COUPON LADY (STANDARD CHARACTER)**. KRAZY COUPON LADY LLC, (U.S. CLS. 100, 101 AND 102). SN 85-374,218. PUB. 1-10-2012. FILED 7-18-2011.
- 4,118,091. **WITMART.COM THE BEST CROWD SOURCING SOLUTION AND DESIGN.** UM TECHNICAL CORPORATION, (U.S. CLS. 100, 101 AND 102). SN 85-374,231. PUB. 1-10-2012. FILED 7-18-2011.
- 4,118,094. **PICK ANOTHER CHECKOUT LANE, HONEY (STANDARD CHARACTER)**. KRAZY COUPON LADY LLC, (U.S. CLS. 100, 101 AND 102). SN 85-374,264. PUB. 1-10-2012. FILED 7-18-2011.
- 4,118,114. **VMBC MOBILE ENABLED AND DESIGN.** CROWE, JESSE, (U.S. CLS. 100, 101 AND 102). SN 85-374,692. PUB. 1-10-2012. FILED 7-19-2011.
- 4,118,116. **PICK-N-DICKERS (STANDARD CHARACTER)**. PICK-N-DICKERS, (U.S. CLS. 100, 101 AND 102). SN 85-374,730. PUB. 1-10-2012. FILED 7-19-2011.
- 4,118,118. **200COLUMBUS (STANDARD CHARACTER)**. COLUMBUS BICENTENNIAL 2012, INC., DBA 200COLUMBUS, (U.S. CLS. 100, 101 AND 102). SN 85-374,736. PUB. 1-10-2012. FILED 7-19-2011.
- 4,118,126. **MISCELLANEOUS DESIGN.** RANGEL, LISA M, (U.S. CLS. 100, 101 AND 102). SN 85-374,956. PUB. 1-10-2012. FILED 7-19-2011.
- 4,118,128. **200 COLUMBUS THE BICENTENNIAL AND DESIGN.** COLUMBUS BICENTENNIAL 2012, INC., DBA 200COLUMBUS, MULTIPLE CLASS, (INT. CLS. 35 AND 41), (U.S. CLS. 100, 101, 102 AND 107). SN 85-374,977. PUB. 1-10-2012. FILED 7-19-2011.
- 4,118,133 (*See Class 9 for this trademark*).
- 4,118,134 (*See Class 9 for this trademark*).
- 4,118,148. **SHOP HAPPY (STANDARD CHARACTER)**. 3TAI-ALER, (U.S. CLS. 100, 101 AND 102). SN 85-375,329. PUB. 1-10-2012. FILED 7-19-2011.
- 4,118,149. **MOVING TARGETS YOU HAVE NEIGHBORS. WE MAKE THEM CUSTOMERS. AND DESIGN.** CORSICA ENTERPRISES, LTD., (U.S. CLS. 100, 101 AND 102). SN 85-375,353. PUB. 1-10-2012. FILED 7-19-2011.
- 4,118,151. **AVAS FLOWERS (STANDARD CHARACTER)**. FLOWER TECH CTR INC, MULTIPLE CLASS, (INT. CLS. 35 AND 39), (U.S. CLS. 100, 101, 102 AND 105). SN 85-375,358. PUB. 1-10-2012. FILED 7-19-2011.
- 4,118,158. **FTW GROUP (STANDARD CHARACTER)**. FTW GROUP, (U.S. CLS. 100, 101 AND 102). SN 85-375,457. PUB. 1-10-2012. FILED 7-19-2011.
- 4,118,159. **LOUD DIGITAL NETWORK (STANDARD CHARACTER)**. EMMIS RADIO, LLC, (U.S. CLS. 100, 101 AND 102). SN 85-375,461. PUB. 1-10-2012. FILED 7-19-2011.
- 4,118,163. **REELSEO (STANDARD CHARACTER)**. ROBERTSON, MARK, (U.S. CLS. 100, 101 AND 102). SN 85-375,501. PUB. 1-10-2012. FILED 7-19-2011.
- 4,118,172 (*See Class 21 for this trademark*).
- 4,118,186. **DOLLAR SQUARE (STANDARD CHARACTER)**. CAROL ANN MARKETING, INC., (U.S. CLS. 100, 101 AND 102). SN 85-376,244. PUB. 1-10-2012. FILED 7-20-2011.
- 4,118,188. **STAND UP OUTFITTERS AND DESIGN.** STAND UP OUTFITTERS LLC, (U.S. CLS. 100, 101 AND 102). SN 85-376,279. PUB. 1-10-2012. FILED 7-20-2011.
- 4,118,189. **HOUGH BAKERIES (STANDARD CHARACTER)**. ARCHIE'S LAKESHORE BAKERY INC., (U.S. CLS. 100, 101 AND 102). SN 85-376,309. PUB. 1-10-2012. FILED 7-20-2011.
- 4,118,192. **TRIM SCENE SOLUTIONS (STANDARD CHARACTER)**. TRIM SCENE SOLUTIONS, INC., MULTIPLE CLASS, (INT. CLS. 35 AND 37), (U.S. CLS. 100, 101, 102, 103

- AND 106). SN 85-376,373. PUB. 1-10-2012. FILED 7-20-2011.
- 4,118,207. **HI TECH TRADER (STANDARD CHARACTER)**. THETA ENTERPRISES INC., DBA HITECHTRADER.COM, (U.S. CLS. 100, 101 AND 102). SN 85-377,160. PUB. 1-10-2012. FILED 7-21-2011.
- 4,118,216. **COUPON COCKTAIL (STANDARD CHARACTER)**. REVIVE MEDIA SOLUTIONS, INC., DBA COUPONCOCKTAIL.COM, (U.S. CLS. 100, 101 AND 102). SN 85-377,494. PUB. 1-10-2012. FILED 7-21-2011.
- 4,118,218. **SPRAY IT DON'T LAY IT AND DESIGN**. PROFILE PRODUCTS LLC, (U.S. CLS. 100, 101 AND 102). SN 85-377,540. PUB. 1-10-2012. FILED 7-21-2011.
- 4,118,221 (*See Class 18 for this trademark*).
- 4,118,223. **GIFTANGO GIFTING, REDEFINED. AND DESIGN**. GIFTANGO CORPORATION, MULTIPLE CLASS, (INT. CLS. 35 AND 42), (U.S. CLS. 100, 101 AND 102). SN 85-377,642. PUB. 1-10-2012. FILED 7-21-2011.
- 4,118,230. **BATHE AND BEAUTY (STANDARD CHARACTER)**. BROOME INTERNATIONAL CONSORTIUM LLC, (U.S. CLS. 100, 101 AND 102). SN 85-377,752. PUB. 1-10-2012. FILED 7-21-2011.
- 4,118,235. **GIFTANGO GIFTING, REDEFINED. AND DESIGN**. GIFTANGO CORPORATION, MULTIPLE CLASS, (INT. CLS. 35 AND 42), (U.S. CLS. 100, 101 AND 102). SN 85-377,840. PUB. 1-10-2012. FILED 7-21-2011.
- 4,118,236 (*See Class 9 for this trademark*).
- 4,118,248. **REALTIME INSIGHTS AND DESIGN**. TARGET RESEARCH GROUP, INC., MULTIPLE CLASS, (INT. CLS. 35 AND 42), (U.S. CLS. 100, 101 AND 102). SN 85-378,572. PUB. 1-10-2012. FILED 7-22-2011.
- 4,118,256. **REDSTONE COMPANIES HOSPITALITY (STANDARD CHARACTER)**. REDSTONE COMPANIES HOSPITALITY, LLC, (U.S. CLS. 100, 101 AND 102). SN 85-378,977. PUB. 1-10-2012. FILED 7-22-2011.
- 4,118,257. **A PERSONAL TOUCH IN EVERY DETAIL (STANDARD CHARACTER)**. REDSTONE COMPANIES HOSPITALITY, LLC, (U.S. CLS. 100, 101 AND 102). SN 85-379,023. PUB. 1-10-2012. FILED 7-22-2011.
- 4,118,264. **MOBILE MARKETING HELPER (STANDARD CHARACTER)**. CORTEZ, KEVIN, (U.S. CLS. 100, 101 AND 102). SN 85-379,709. PUB. 1-10-2012. FILED 7-25-2011.
- 4,118,270. **NATIONAL MEN'S MASTERS CHAMPIONSHIP MASTERS BASKETBALL USA AND DESIGN**. MASTERS BASKETBALL USA, (U.S. CLS. 100, 101 AND 102). SN 85-379,993. PUB. 1-10-2012. FILED 7-25-2011.
- 4,118,271 (*See Class 14 for this trademark*).
- 4,118,273. **TEA PARTY EXPRESS (STANDARD CHARACTER)**. OUR COUNTRY DESERVES BETTER PAC, (U.S. CLS. 100, 101 AND 102). SN 85-380,062. PUB. 1-10-2012. FILED 7-25-2011.
- 4,118,280. **DIRODDI (STANDARD CHARACTER)**. DIRODDI, MULTIPLE CLASS, (INT. CLS. 35 AND 42), (U.S. CLS. 100, 101 AND 102). SN 85-380,291. PUB. 1-10-2012. FILED 7-25-2011.
- 4,118,285. **ABLE MADE (STANDARD CHARACTER)**. ABLE MADE LLC, (U.S. CLS. 100, 101 AND 102). SN 85-380,434. PUB. 1-10-2012. FILED 7-25-2011.
- 4,118,286. **LLAURADOR WINES (STANDARD CHARACTER)**. PASTOR, JOSE, (U.S. CLS. 100, 101 AND 102). SN 85-380,452. PUB. 1-10-2012. FILED 7-25-2011.
- 4,118,287. **MARSHALL'S INDUSTRIAL HARDWARE AND DESIGN**. MARSHALL'S INDUSTRIAL HARDWARE, INC., (U.S. CLS. 100, 101 AND 102). SN 85-380,456. PUB. 1-10-2012. FILED 7-25-2011.
- 4,118,288. **CHICK CRAWL AND DESIGN**. WOLBRUECK, SUSAN J, (U.S. CLS. 100, 101 AND 102). SN 85-380,475. PUB. 1-10-2012. FILED 7-25-2011.
- 4,118,319. **1 OF A FIND (STANDARD CHARACTER)**. 1 OF A FIND NYC, INC., (U.S. CLS. 100, 101 AND 102). SN 85-387,533. PUB. 1-10-2012. FILED 8-2-2011.
- 4,118,326. **PLANET GREEN ELECTRIC SCOOTER CO. (STANDARD CHARACTER)**. QUEMED INTERNATIONAL, INC., (U.S. CLS. 100, 101 AND 102). SN 85-388,031. PUB. 1-10-2012. FILED 8-3-2011.
- 4,118,335. **TRIAGE (STANDARD CHARACTER)**. TRIAGE CONSULTING GROUP, (U.S. CLS. 100, 101 AND 102). SN 85-388,456. PUB. 1-10-2012. FILED 8-3-2011.
- 4,118,343. **VONLAY (STANDARD CHARACTER)**. VONLAY, LLC, (U.S. CLS. 100, 101 AND 102). SN 85-389,130. PUB. 1-10-2012. FILED 8-4-2011.
- 4,118,344. **DETECTING TOMORROW'S CANCER TODAY (STANDARD CHARACTER)**. WILMINGTON ENDOCRINOLOGY, P.A., MULTIPLE CLASS, (INT. CLS. 35, 42 AND 44), (U.S. CLS. 100, 101 AND 102). SN 85-389,150. PUB. 1-10-2012. FILED 8-4-2011.
- 4,118,357. **GAB-E (STANDARD CHARACTER)**. ATTITUDE MEASUREMENT CORPORATION, (U.S. CLS. 100, 101 AND 102). SN 85-390,032. PUB. 1-10-2012. FILED 8-4-2011.
- 4,118,366. **JUMP BACK IN (STANDARD CHARACTER)**. SCLC, INC., (U.S. CLS. 100, 101 AND 102). SN 85-390,404. PUB. 1-10-2012. FILED 8-5-2011.
- 4,118,368. **CITIZENSHIPWORKS (STANDARD CHARACTER)**. PRO BONO NET, INC., (U.S. CLS. 100, 101 AND 102). SN 85-390,709. PUB. 1-10-2012. FILED 8-5-2011.
- 4,118,370. **CITIZENSHIPWORKS AND DESIGN**. PRO BONO NET, INC., (U.S. CLS. 100, 101 AND 102). SN 85-390,731. PUB. 1-10-2012. FILED 8-5-2011.
- 4,118,374. **MISCELLANEOUS DESIGN**. PRO BONO NET, INC., (U.S. CLS. 100, 101 AND 102). SN 85-390,865. PUB. 1-10-2012. FILED 8-5-2011.
- 4,118,379. **YEPWORD (STANDARD CHARACTER)**. ADASIM INC, MULTIPLE CLASS, (INT. CLS. 35 AND 38), (U.S. CLS. 100, 101, 102 AND 104). SN 85-391,074. PUB. 1-10-2012. FILED 8-5-2011.
- 4,118,381. **CARLO'S (STANDARD CHARACTER)**. BUDDY V ENTERTAINMENT, LLC, (U.S. CLS. 100, 101 AND 102). SN 85-391,382. PUB. 1-10-2012. FILED 8-6-2011.
- 4,118,390. **KNOWTA (STANDARD CHARACTER)**. THE PRINTER PROJECT, DBA KNOWTA, MULTIPLE CLASS, (INT. CLS. 35, 38 AND 40), (U.S. CLS. 100, 101, 102, 103, 104 AND 106). SN 85-391,984. PUB. 1-10-2012. FILED 8-8-2011.
- 4,118,401. **TECHNOLOGY FOR CONSTRUCTION (STANDARD CHARACTER)**. HANLEY-WOOD, LLC, (U.S. CLS. 100, 101 AND 102). SN 85-392,223. PUB. 1-10-2012. FILED 8-8-2011.
- 4,118,422. **EQUALITY FLORIDA (STANDARD CHARACTER)**. EQUALITY FLORIDA, INC., AND EQUALITY FLORIDA INSTITUTE, INC., (U.S. CLS. 100, 101 AND 102). SN 85-392,709. PUB. 1-10-2012. FILED 8-8-2011.
- 4,118,423. **EQUALITY FLORIDA AND DESIGN**. EQUALITY FLORIDA, INC., AND EQUALITY FLORIDA INSTITUTE, INC., (U.S. CLS. 100, 101 AND 102). SN 85-392,715. PUB. 1-10-2012. FILED 8-8-2011.
- 4,118,424. **D (STYLIZED)**. THE DORA KAN GROUP, LLC, (U.S. CLS. 100, 101 AND 102). SN 85-392,781. PUB. 1-10-2012. FILED 8-8-2011.
- 4,118,425. **BIDWHAMMY (STANDARD CHARACTER)**. BIDWHAMMY, LLC, (U.S. CLS. 100, 101 AND 102). SN 85-392,800. PUB. 1-10-2012. FILED 8-9-2011.
- 4,118,437. **RENTerval (STANDARD CHARACTER)**. RENTerval LLC, (U.S. CLS. 100, 101 AND 102). SN 85-393,064. PUB. 1-10-2012. FILED 8-9-2011.
- 4,118,451. **XPRES (STYLIZED)**. TIGER VALUATION SERVICES LLC, (U.S. CLS. 100, 101 AND 102). SN 85-393,271. PUB. 1-10-2012. FILED 8-9-2011.
- 4,118,452. **GBC MOTORSPORTS (STANDARD CHARACTER)**. GREENBALL CORPORATION, (U.S. CLS. 100, 101 AND 102). SN 85-393,279. PUB. 1-10-2012. FILED 8-9-2011.
- 4,118,458 (*See Class 18 for this trademark*).
- 4,118,462. **PLEASE GO AND ENJOY YOUR LIFE, DANNY DID. (STANDARD CHARACTER)**. DANNY DID FOUNDATION, (U.S. CLS. 100, 101 AND 102). SN 85-393,377. PUB. 1-10-2012. FILED 8-9-2011.
- 4,118,465. **THE MISSION CONTINUES (STANDARD CHARACTER)**. THE CENTER FOR CITIZEN LEADERSHIP, (U.S. CLS. 100, 101 AND 102). SN 85-393,410. PUB. 1-10-2012. FILED 8-9-2011.
- 4,118,467. **XPRES (STANDARD CHARACTER)**. TIGER VALUATION SERVICES LLC, (U.S. CLS. 100, 101 AND 102). SN 85-393,463. PUB. 1-10-2012. FILED 8-9-2011.
- 4,118,468. **GBC MOTORSPORTS AND DESIGN**. GREENBALL CORPORATION, (U.S. CLS. 100, 101 AND 102). SN 85-393,500. PUB. 1-10-2012. FILED 8-9-2011.
- 4,118,471. **SAVE WORKS (STANDARD CHARACTER)**. ALAN GOULD, (U.S. CLS. 100, 101 AND 102). SN 85-393,522. PUB. 1-10-2012. FILED 8-9-2011.

- 4,118,472. **KEITER STEPHENS (STANDARD CHARACTER)**. KEITER, STEPHENS, HURST, GARY & SHREAVES, P.C., (U.S. CLS. 100, 101 AND 102). SN 85-393,545. PUB. 1-10-2012. FILED 8-9-2011.
- 4,118,482. **BETTERBUYDESIGN (STANDARD CHARACTER)**. MOTT, STEPHEN CRAIG, (U.S. CLS. 100, 101 AND 102). SN 85-393,777. PUB. 1-10-2012. FILED 8-9-2011.
- 4,118,483. **HAPPINESS IS CALLING (STANDARD CHARACTER)**. SAN DIEGO CONVENTION AND TOURIST BUREAU, DBA SAN DIEGO CONVENTION AND VISITORS BUREAU, (U.S. CLS. 100, 101 AND 102). SN 85-393,823. PUB. 1-10-2012. FILED 8-9-2011.
- 4,118,484. **HAPPINESS IS CALLING, ANSWER THE CALL (STANDARD CHARACTER)**. SAN DIEGO CONVENTION AND TOURIST BUREAU, DBA SAN DIEGO CONVENTION AND VISITORS BUREAU, (U.S. CLS. 100, 101 AND 102). SN 85-393,840. PUB. 1-10-2012. FILED 8-9-2011.
- 4,118,498. **CLEAR, CONCISE, CONSISTENT, COMMUNICATION PROCESS (STANDARD CHARACTER)**. VENDRE STORE LLC, (U.S. CLS. 100, 101 AND 102). SN 85-394,126. PUB. 1-10-2012. FILED 8-10-2011.
- 4,118,505. **PETCHING! (STANDARD CHARACTER)**. LCS ENTERPRISE LLC, (U.S. CLS. 100, 101 AND 102). SN 85-394,301. PUB. 1-10-2012. FILED 8-10-2011.
- 4,118,507. **MISCELLANEOUS DESIGN**. BETA THETA PI, DBA BETA THETA PI FRATERNITY, (U.S. CLS. 100, 101 AND 102). SN 85-394,351. PUB. 1-10-2012. FILED 8-10-2011.
- 4,118,510. **VERTIFICATE (STANDARD CHARACTER)**. VIRTUAL MEDIA LLC, (U.S. CLS. 100, 101 AND 102). SN 85-394,423. PUB. 1-10-2012. FILED 8-10-2011.
- 4,118,521. **IH AND DESIGN**. IHISPANO.COM, LLC, MULTIPLE CLASS, (INT. CLS. 35, 38, 42 AND 45), (U.S. CLS. 100, 101, 102 AND 104). SN 85-394,642. PUB. 1-10-2012. FILED 8-10-2011.
- 4,118,526. **COLLABORATIVE FAMILY LAW ASSOCIATION AND DESIGN**. THE COLLABORATIVE LAW ASSOCIATION, (U.S. CLS. 100, 101 AND 102). SN 85-394,828. PUB. 1-10-2012. FILED 8-10-2011.
- 4,118,534. **DOGTREKKER (STANDARD CHARACTER)**. DOGTREKKER, INC., (U.S. CLS. 100, 101 AND 102). SN 85-394,939. PUB. 1-10-2012. FILED 8-10-2011.
- 4,118,542. **SEAMS TO FIT (STANDARD CHARACTER)**. LINDER, SHERRY, DBA SEAMS TO FIT, (U.S. CLS. 100, 101 AND 102). SN 85-395,024. PUB. 1-10-2012. FILED 8-11-2011.
- 4,118,544. **IMAPMYTEAM (STANDARD CHARACTER)**. STRATEGIC SOLUTIONS INTERNATIONAL, INC., MULTIPLE CLASS, (INT. CLS. 35 AND 45), (U.S. CLS. 100, 101 AND 102). SN 85-395,058. PUB. 1-10-2012. FILED 8-11-2011.
- 4,118,545. **IMAPMYCAREER (STANDARD CHARACTER)**. STRATEGIC SOLUTIONS INTERNATIONAL, INC., MULTIPLE CLASS, (INT. CLS. 35 AND 42), (U.S. CLS. 100, 101 AND 102). SN 85-395,061. PUB. 1-10-2012. FILED 8-11-2011.
- 4,118,560. **CONN'S (STYLIZED)**. CONN'S, INC., (U.S. CLS. 100, 101 AND 102). SN 85-395,422. PUB. 1-10-2012. FILED 8-11-2011.
- 4,118,596. **PPP PORTLAND PEDAL POWER AND DESIGN**. PORTLAND PEDAL POWER, LLC, (U.S. CLS. 100, 101 AND 102). SN 85-396,068. PUB. 1-10-2012. FILED 8-11-2011.
- 4,118,604. **NUTRICITY (STANDARD CHARACTER)**. NUTRICITY.COM, LLC, (U.S. CLS. 100, 101 AND 102). SN 85-396,246. PUB. 1-10-2012. FILED 8-12-2011.
- 4,118,616. **WESTERN WEAR FOR THE WAY YOU LIVE (STANDARD CHARACTER)**. SHEPLERS, INC., (U.S. CLS. 100, 101 AND 102). SN 85-396,637. PUB. 1-10-2012. FILED 8-12-2011.
- 4,118,655. **JABIAN (STANDARD CHARACTER)**. JABIAN, LLC, (U.S. CLS. 100, 101 AND 102). SN 85-397,267. PUB. 1-10-2012. FILED 8-13-2011.
- 4,118,658. **STRATEGY THAT WORKS (STANDARD CHARACTER)**. JABIAN, LLC, (U.S. CLS. 100, 101 AND 102). SN 85-397,271. PUB. 1-10-2012. FILED 8-13-2011.
- 4,118,661. **SPREAD (STANDARD CHARACTER)**. MONAD CORPORATION, DBA MONAD, (U.S. CLS. 100, 101 AND 102). SN 85-397,301. PUB. 1-10-2012. FILED 8-13-2011.
- 4,118,663. **LOOK FOR THE LOGO (STANDARD CHARACTER)**. GOOD SPORTS, INC., (U.S. CLS. 100, 101 AND 102). SN 85-397,582. PUB. 1-10-2012. FILED 8-15-2011.
- 4,118,670. **BLISSFUL WELLNESS (STANDARD CHARACTER)**. BLISSFUL WELLNESS MEDICAL WEIGHT LOSS CENTERS, LLC, MULTIPLE CLASS, (INT. CLS. 35, 41 AND 44), (U.S. CLS. 100, 101, 102 AND 107). SN 85-401,713. PUB. 1-10-2012. FILED 8-18-2011.
- 4,118,671. **MISCELLANEOUS DESIGN**. BLISSFUL WELLNESS MEDICAL WEIGHT LOSS CENTERS, LLC, MULTIPLE CLASS, (INT. CLS. 35, 41 AND 44), (U.S. CLS. 100, 101, 102 AND 107). SN 85-401,731. PUB. 1-10-2012. FILED 8-18-2011.
- 4,118,672. **WHAT'S MOO? (STANDARD CHARACTER)**. DAIRY MANAGEMENT, INC., MULTIPLE CLASS, (INT. CLS. 35 AND 41), (U.S. CLS. 100, 101, 102 AND 107). SN 85-401,733. PUB. 1-10-2012. FILED 8-18-2011.
- 4,118,675. **877-4BUYMAX (STANDARD CHARACTER)**. CLOCKWORK IP, LLC, (U.S. CLS. 100, 101 AND 102). SN 85-402,196. PUB. 1-10-2012. FILED 8-19-2011.
- 4,118,676. **HSC HENRY SCHEIN CARES AND DESIGN**. HS TM, LLC, MULTIPLE CLASS, (INT. CLS. 35 AND 44), (U.S. CLS. 100, 101 AND 102). SN 85-403,740. PUB. 1-10-2012. FILED 8-22-2011.
- 4,118,686. **CONNECTED INTELLIGENCE AND DESIGN**. CURRENT GROUP, LLC, MULTIPLE CLASS, (INT. CLS. 35, 39 AND 42), (U.S. CLS. 100, 101, 102 AND 105). SN 85-408,700. PUB. 1-10-2012. FILED 8-26-2011.
- 4,118,689. **ECX GLOBAL LOGISTICS AND DESIGN**. EURO CARGO EXPRESS, INC., MULTIPLE CLASS, (INT. CLS. 35 AND 39), (U.S. CLS. 100, 101, 102 AND 105). SN 85-411,106. PUB. 1-10-2012. FILED 8-30-2011.
- 4,118,722. **SMALLCAKES A CUPCAKERY AND DESIGN**. SMALLCAKES, LLC, (U.S. CLS. 100, 101 AND 102). SN 85-442,141. PUB. 1-10-2012. FILED 10-7-2011.
- 4,118,726 (*See Class 1 for this trademark*).
- 4,118,727. **MISCELLANEOUS DESIGN**. AMERICAN AUTOMOBILE ASSOCIATION, INC., (U.S. CLS. 100, 101 AND 102). SN 85-446,367. PUB. 1-10-2012. FILED 10-13-2011.
- 4,118,739. **RE:INVENTION (STANDARD CHARACTER)**. RE:INVENTION, INC., (U.S. CLS. 100, 101 AND 102). SN 85-461,575. PUB. 1-10-2012. FILED 11-1-2011.
- 4,118,742. **A LIFE (STANDARD CHARACTER)**. KIM, DANIEL KYONG C., (U.S. CLS. 100, 101 AND 102). SN 85-473,271. PUB. 1-10-2012. FILED 11-15-2011.
- 4,118,747. **EVERY CONNECTION IS A NEW OPPORTUNITY (STANDARD CHARACTER)**. PITNEY BOWES INC., (U.S. CLS. 100, 101 AND 102). SN 85-976,004. PUB. 1-10-2012. FILED 9-1-2010.

CLASS 36—INSURANCE AND FINANCIAL

- 4,116,556. **COLLEGECOUNTS 529 FUND (STYLIZED)**. ALABAMA STATE TREASURER'S OFFICE, (U.S. CLS. 100, 101 AND 102). SN 76-699,783. PUB. 1-10-2012. FILED 10-8-2009.
- 4,116,568. **EMERGINGWEALTH INVESTMENT MANAGEMENT, INC. (STANDARD CHARACTER)**. EMERGINGWEALTH INVESTMENT MANAGEMENT, INC., (U.S. CLS. 100, 101 AND 102). SN 76-706,264. PUB. 1-10-2012. FILED 2-3-2011.
- 4,116,594 (*See Class 19 for this trademark*).
- 4,116,601. **GG INC. THE GUESS GROUP, INC. A REAL ESTATE SERVICES COMPANY AND DESIGN**. THE GUESS GROUP, INC., AND JOHN L. GUESS, (U.S. CLS. 100, 101 AND 102). SN 77-494,632. PUB. 11-11-2008. FILED 6-9-2008.
- 4,116,608. **LADA SEARCH (STANDARD CHARACTER)**. OKI ELECTRIC INDUSTRY CO., LTD., MULTIPLE CLASS, (INT. CLS. 36, 39, 41, 43 AND 44), (U.S. CLS. 100, 101, 102, 105 AND 107). SN 77-653,608. PUB. 1-10-2012. FILED 1-21-2009.
- 4,116,627. **LUMINHAUS (STANDARD CHARACTER)**. WATSON, JENNIFER L, AND BLESS, BARRY R, (U.S. CLS. 100, 101 AND 102). SN 77-792,846. PUB. 1-10-2012. FILED 7-29-2009.
- 4,116,665. **FRYS.COM OPEN (STANDARD CHARACTER)**. FRY'S ELECTRONICS, INC., MULTIPLE CLASS, (INT. CLS. 36 AND 41), (U.S. CLS. 100, 101, 102 AND 107). SN 77-980,620. PUB. 1-10-2012. FILED 8-31-2009.
- 4,116,693. **BANCOCIVICO AND DESIGN**. CAJA DE AHOR-

- ROS Y MONTE DE PIEDAD DE NAVARRA, (U.S. CLS. 100, 101 AND 102). SN 79-085,282. PUB. 1-10-2012. FILED 6-2-2010.
- 4,116,712 (*See Class 10 for this trademark*).
- 4,116,718 (*See Class 10 for this trademark*).
- 4,116,724 (*See Class 9 for this trademark*).
- 4,116,729 (*See Class 9 for this trademark*).
- 4,116,761 (*See Class 7 for this trademark*).
- 4,116,776 (*See Class 35 for this trademark*).
- 4,116,890. **FRENCH MARKET DISTRICT EST. 1791 AND DESIGN**. FRENCH MARKET CORPORATION, (U.S. CLS. 100, 101 AND 102). SN 85-047,337. PUB. 1-10-2012. FILED 5-25-2010.
- 4,116,891. **DRIVE (STANDARD CHARACTER)**. ENSEMBLE REAL ESTATE SERVICES, INC., MULTIPLE CLASS, (INT. CLS. 36 AND 37), (U.S. CLS. 100, 101, 102, 103 AND 106). SN 85-049,243. PUB. 1-10-2012. FILED 5-27-2010.
- 4,116,942. **RENT WITH CONFIDENCE (STANDARD CHARACTER)**. FEDERATION OF RENTAL-HOUSING PROVIDERS OF ONTARIO, (U.S. CLS. 100, 101 AND 102). SN 85-121,585. PUB. 1-10-2012. FILED 9-2-2010.
- 4,116,962. **DW INVESTMENT COUNSEL (STANDARD CHARACTER)**. THE BANK OF NOVA SCOTIA, (U.S. CLS. 100, 101 AND 102). SN 85-142,965. PUB. 1-10-2012. FILED 10-1-2010.
- 4,116,966. **CHICAGO TRADING COMPANY (STANDARD CHARACTER)**. CTC HOLDINGS, L.P., (U.S. CLS. 100, 101 AND 102). SN 85-150,466. PUB. 1-10-2012. FILED 10-12-2010.
- 4,116,973. **BK LIFEBOAT (STANDARD CHARACTER)**. JANET MARTIN CONSULTING, INC, (U.S. CLS. 100, 101 AND 102). SN 85-158,293. PUB. 1-10-2012. FILED 10-21-2010.
- 4,116,982. **WFI (STANDARD CHARACTER)**. WIRELESS FACILITIES, INC., MULTIPLE CLASS, (INT. CLS. 36, 37, 38, 42 AND 45), (U.S. CLS. 100, 101, 102, 103, 104 AND 106). SN 85-170,274. PUB. 1-10-2012. FILED 11-5-2010.
- 4,116,992. **HUA NAN (STANDARD CHARACTER)**. HUA NAN FINANCIAL HOLDINGS CO., LTD., (U.S. CLS. 100, 101 AND 102). SN 85-187,603. PUB. 1-10-2012. FILED 11-30-2010.
- 4,116,993. **MISCELLANEOUS DESIGN**. HUA NAN FINANCIAL HOLDINGS CO., LTD., (U.S. CLS. 100, 101 AND 102). SN 85-187,617. PUB. 1-10-2012. FILED 11-30-2010.
- 4,116,998. **OTTER CARES AND DESIGN**. OTTER PRODUCTS, LLC, (U.S. CLS. 100, 101 AND 102). SN 85-188,662. PUB. 1-10-2012. FILED 12-1-2010.
- 4,117,000. **PA PROAG AND DESIGN**. PRODUCERS AG INSURANCE GROUP, INC., (U.S. CLS. 100, 101 AND 102). SN 85-189,929. PUB. 1-10-2012. FILED 12-3-2010.
- 4,117,022 (*See Class 9 for this trademark*).
- 4,117,023 (*See Class 9 for this trademark*).
- 4,117,024 (*See Class 9 for this trademark*).
- 4,117,029. **DYAL CAPITAL PARTNERS (STANDARD CHARACTER)**. NEUBERGER BERMAN GROUP LLC, (U.S. CLS. 100, 101 AND 102). SN 85-204,396. PUB. 1-10-2012. FILED 12-22-2010.
- 4,117,030 (*See Class 35 for this trademark*).
- 4,117,034. **RAYMARINE RAPID CARE (STANDARD CHARACTER)**. RAYMARINE UK LIMITED, (U.S. CLS. 100, 101 AND 102). SN 85-207,350. PUB. 1-10-2012. FILED 12-29-2010.
- 4,117,039 (*See Class 35 for this trademark*).
- 4,117,063 (*See Class 35 for this trademark*).
- 4,117,064. **WE'RE BRINGING THE TOWN SQUARE BACK TO THE NEIGHBORHOOD (STANDARD CHARACTER)**. WEITZMAN MANAGEMENT CORPORATION, MULTIPLE CLASS, (INT. CLS. 36 AND 37), (U.S. CLS. 100, 101, 102, 103 AND 106). SN 85-220,042. PUB. 1-10-2012. FILED 1-18-2011.
- 4,117,069. **MOUNTAINVIEW (STANDARD CHARACTER)**. MOUNTAINVIEW CAPITAL HOLDINGS, LLC, (U.S. CLS. 100, 101 AND 102). SN 85-220,865. PUB. 1-10-2012. FILED 1-19-2011.
- 4,117,079. **EDU LAUNCH PAD (STANDARD CHARACTER)**. EDULAUNCHPAD.COM, L.L.C., MULTIPLE CLASS, (INT. CLS. 36 AND 41), (U.S. CLS. 100, 101, 102 AND 107). SN 85-222,623. PUB. 1-10-2012. FILED 1-20-2011.
- 4,117,080. **EDU LAUNCH PAD AND DESIGN**. EDULAUNCHPAD.COM, L.L.C., MULTIPLE CLASS, (INT. CLS. 36 AND 41), (U.S. CLS. 100, 101, 102 AND 107). SN 85-222,637. PUB. 1-10-2012. FILED 1-20-2011.
- 4,117,091. **AGGIE ANGEL NETWORK (STANDARD CHARACTER)**. AGGIE ANGEL NETWORK, INC., DBA AGGIE ANGEL NETWORK, (U.S. CLS. 100, 101 AND 102). SN 85-224,731. PUB. 10-4-2011. FILED 1-24-2011.
- 4,117,096 (*See Class 35 for this trademark*).
- 4,117,097. **714 TICKETS CALL TODAY! GO TONIGHT! AND DESIGN**. RT&H, INC., (U.S. CLS. 100, 101 AND 102). SN 85-225,743. PUB. 1-10-2012. FILED 1-25-2011.
- 4,117,105 (*See Class 35 for this trademark*).
- 4,117,124 (*See Class 35 for this trademark*).
- 4,117,125. **INTECH (STANDARD CHARACTER)**. INTECH INVESTMENT MANAGEMENT LLC, (U.S. CLS. 100, 101 AND 102). SN 85-230,973. PUB. 1-10-2012. FILED 2-1-2011.
- 4,117,127. **FEED THE CHILDREN (STANDARD CHARACTER)**. FEED THE CHILDREN, INC., MULTIPLE CLASS, (INT. CLS. 36, 41, 43 AND 44), (U.S. CLS. 100, 101, 102 AND 107). SN 85-231,294. PUB. 1-10-2012. FILED 2-1-2011.
- 4,117,132. **FAST AUTHORIZE AND DESIGN**. CARDSMITH, LLC, (U.S. CLS. 100, 101 AND 102). SN 85-231,881. PUB. 1-10-2012. FILED 2-1-2011.
- 4,117,143 (*See Class 9 for this trademark*).
- 4,117,147 (*See Class 16 for this trademark*).
- 4,117,180 (*See Class 35 for this trademark*).
- 4,117,186. **INTEGRIS (STANDARD CHARACTER)**. INTEGRIS WEALTH MANAGEMENT, LLC, (U.S. CLS. 100, 101 AND 102). SN 85-238,903. PUB. 1-10-2012. FILED 2-10-2011.
- 4,117,213. **MISCELLANEOUS DESIGN**. USA-FORECLOSURE.COM, LLC, (U.S. CLS. 100, 101 AND 102). SN 85-242,017. PUB. 1-10-2012. FILED 2-14-2011.
- 4,117,241. **PHOENIX REALTY ADVISORS (STANDARD CHARACTER)**. PHOENIX REALTY ADVISORS, INC., (U.S. CLS. 100, 101 AND 102). SN 85-247,587. PUB. 1-10-2012. FILED 2-21-2011.
- 4,117,256. **RMS (STANDARD CHARACTER)**. RISK MANAGEMENT SOLUTIONS, INC., (U.S. CLS. 100, 101 AND 102). SN 85-250,625. PUB. 12-6-2011. FILED 2-24-2011.
- 4,117,265 (*See Class 35 for this trademark*).
- 4,117,278 (*See Class 35 for this trademark*).
- 4,117,284. **TOLI VAULT (STANDARD CHARACTER)**. THE TOLI GROUP, MULTIPLE CLASS, (INT. CLS. 36 AND 39), (U.S. CLS. 100, 101, 102 AND 105). SN 85-257,945. PUB. 1-10-2012. FILED 3-4-2011.
- 4,117,290. **PROTECTING WHAT YOU OWN (STANDARD CHARACTER)**. FULLER INSURANCE AGENCY, (U.S. CLS. 100, 101 AND 102). SN 85-259,301. PUB. 1-10-2012. FILED 3-7-2011.
- 4,117,321. **GO GREEN AND DESIGN**. BLUESTAR ENERGY SERVICES, INC., (U.S. CLS. 100, 101 AND 102). SN 85-266,292. PUB. 1-10-2012. FILED 3-14-2011.
- 4,117,333 (*See Class 35 for this trademark*).
- 4,117,334. **ACTIVE WATER (STANDARD CHARACTER)**. ACTIVE WATER, (U.S. CLS. 100, 101 AND 102). SN 85-268,033. PUB. 1-10-2012. FILED 3-16-2011.
- 4,117,340. **GIVEBUDDY.COM AND DESIGN**. GIVES BACK COMPANY, LLC, (U.S. CLS. 100, 101 AND 102). SN 85-269,459. PUB. 1-10-2012. FILED 3-17-2011.
- 4,117,354 (*See Class 35 for this trademark*).
- 4,117,399. **SIGN-N-BUY (STANDARD CHARACTER)**. ENVIRONMENTAL REMEDIATION AND FINANCIAL SERVICES LLC, (U.S. CLS. 100, 101 AND 102). SN 85-282,058. PUB. 1-10-2012. FILED 3-31-2011.
- 4,117,400. **OBIZ (STANDARD CHARACTER)**. ENVIRONMENTAL REMEDIATION AND FINANCIAL SERVICES LLC, (U.S. CLS. 100, 101 AND 102). SN 85-282,116. PUB. 1-10-2012. FILED 3-31-2011.
- 4,117,419. **IPREPAID AND DESIGN**. GRABOW, JIM, (U.S. CLS. 100, 101 AND 102). SN 85-286,638. PUB. 1-10-2012. FILED 4-5-2011.
- 4,117,451. **TRADE EFFICIENCY SCORES (TES) (STANDARD CHARACTER)**. BARCLAYS BANK PLC, (U.S. CLS. 100, 101 AND 102). SN 85-293,118. PUB. 1-10-2012. FILED 4-12-2011.
- 4,117,453 (*See Class 35 for this trademark*).
- 4,117,462. **MOM PROM (STANDARD CHARACTER)**. CRAPPS, ELIZABETH, (U.S. CLS. 100, 101 AND 102). SN 85-294,673. PUB. 1-10-2012. FILED 4-13-2011.
- 4,117,468 (*See Class 25 for this trademark*).
- 4,117,476 (*See Class 35 for this trademark*).
- 4,117,485. **MEMBER MILES AND DESIGN**. VANTIV, LLC,

- (U.S. CLS. 100, 101 AND 102). SN 85-298,830. PUB. 1-10-2012. FILED 4-19-2011.
- 4,117,493. **WINDHAVEN INVESTMENT MANAGEMENT AND DESIGN**. CHARLES SCHWAB & CO., INC., (U.S. CLS. 100, 101 AND 102). SN 85-301,184. PUB. 1-10-2012. FILED 4-21-2011.
- 4,117,501 (*See Class 35 for this trademark*).
- 4,117,533. **HOGANS (STANDARD CHARACTER)**. THE HOGANS AGENCY, INC., (U.S. CLS. 100, 101 AND 102). SN 85-309,055. PUB. 1-10-2012. FILED 4-30-2011.
- 4,117,540. **TEAM ASSET STRATEGY FUND AND DESIGN**. TEAM FINANCIAL ASSET MANAGEMENT LLC, (U.S. CLS. 100, 101 AND 102). SN 85-311,037. PUB. 10-4-2011. FILED 5-3-2011.
- 4,117,541. **ALL REAL ESTATE SOLUTIONS, LLC AND DESIGN**. ALL REAL ESTATE SOLUTIONS, LLC, (U.S. CLS. 100, 101 AND 102). SN 85-311,096. PUB. 1-10-2012. FILED 5-3-2011.
- 4,117,576. **CELLGUARD (STANDARD CHARACTER)**. CELLGUARD, INC., (U.S. CLS. 100, 101 AND 102). SN 85-320,311. PUB. 10-4-2011. FILED 5-13-2011.
- 4,117,597. **NCTUE (STANDARD CHARACTER)**. NATIONAL CONSUMER TELECOM & UTILITIES EXCHANGE, (U.S. CLS. 100, 101 AND 102). SN 85-324,106. PUB. 1-10-2012. FILED 5-18-2011.
- 4,117,606. **LINCOLN ABSTRACT & SETTLEMENT SERVICES (STANDARD CHARACTER)**. LINCOLN APPRAISAL & SETTLEMENT SERVICES, LLC, MULTIPLE CLASS, (INT. CLS. 36 AND 45), (U.S. CLS. 100, 101 AND 102). SN 85-324,747. PUB. 1-10-2012. FILED 5-19-2011.
- 4,117,613 (*See Class 35 for this trademark*).
- 4,117,626. **GALT INVESTMENTS (STANDARD CHARACTER)**. GALT INVESTMENT MANAGEMENT LLC, (U.S. CLS. 100, 101 AND 102). SN 85-328,875. PUB. 1-10-2012. FILED 5-24-2011.
- 4,117,627. **RS | INVESTMENTS AND DESIGN**. THE GUARDIAN LIFE INSURANCE COMPANY OF AMERICA, (U.S. CLS. 100, 101 AND 102). SN 85-328,886. PUB. 1-10-2012. FILED 5-24-2011.
- 4,117,634 (*See Class 9 for this trademark*).
- 4,117,645. **THE BASIS POINT (STANDARD CHARACTER)**. THE BASIS POINT, INC., MULTIPLE CLASS, (INT. CLS. 36 AND 41), (U.S. CLS. 100, 101, 102 AND 107). SN 85-333,167. PUB. 1-10-2012. FILED 5-28-2011.
- 4,117,653. **MENKE ESOPONLINE SERVICES (STANDARD CHARACTER)**. MENKE & ASSOCIATES, INC., DBA MENKE ESOPONLINE SERVICES, AND THE MENKE GROUP, INC., AKA THE MENKE GROUP, (U.S. CLS. 100, 101 AND 102). SN 85-334,422. PUB. 1-10-2012. FILED 5-31-2011.
- 4,117,657. **GOLD RIBBON ALLIANCE FIGHTING CHILDHOOD CANCER TOGETHER (STANDARD CHARACTER)**. THE KAYLYN ELAINE WARREN FOUNDATION, (U.S. CLS. 100, 101 AND 102). SN 85-335,051. PUB. 1-10-2012. FILED 6-1-2011.
- 4,117,659. **INSIDER'S CLUB (STANDARD CHARACTER)**. UNIVERSAL AIR TRAVEL PLAN, INC., (U.S. CLS. 100, 101 AND 102). SN 85-335,327. PUB. 1-10-2012. FILED 6-1-2011.
- 4,117,698. **A+ APARTMENT LOCATING (STANDARD CHARACTER)**. WILSON, TINDALL & ASSOCIATES, INC., (U.S. CLS. 100, 101 AND 102). SN 85-344,022. PUB. 1-10-2012. FILED 6-12-2011.
- 4,117,719. **BP BLACKWOOD PROPERTIES, INC. AND DESIGN**. BLACKWOOD PROPERTIES, INC., (U.S. CLS. 100, 101 AND 102). SN 85-347,457. PUB. 1-10-2012. FILED 6-15-2011.
- 4,117,725. **POLE FOR A CAUSE AND DESIGN**. POLE SPORT ENTERPRISE INC., (U.S. CLS. 100, 101 AND 102). SN 85-348,625. PUB. 1-10-2012. FILED 6-16-2011.
- 4,117,780. **WE ARE EM (STANDARD CHARACTER)**. GRAMERCY FUNDS MANAGEMENT LLC, (U.S. CLS. 100, 101 AND 102). SN 85-355,707. PUB. 1-10-2012. FILED 6-24-2011.
- 4,117,799 (*See Class 14 for this trademark*).
- 4,117,808. **TAASSOCIATES AND DESIGN**. TA ASSOCIATES MANAGEMENT L.P., (U.S. CLS. 100, 101 AND 102). SN 85-359,048. PUB. 1-10-2012. FILED 6-29-2011.
- 4,117,816 (*See Class 35 for this trademark*).
- 4,117,824 (*See Class 35 for this trademark*).
- 4,117,847. **COMERICA GUARDIAN ANGELS ACCOUNT (STANDARD CHARACTER)**. COMERICA INCORPORATED, (U.S. CLS. 100, 101 AND 102). SN 85-364,286. PUB. 1-10-2012. FILED 7-6-2011.
- 4,117,864. **PROSPERITYBUILDER SIGNATURE LOAN (STANDARD CHARACTER)**. EUROTUX IP HOLDINGS, (U.S. CLS. 100, 101 AND 102). SN 85-365,113. PUB. 1-10-2012. FILED 7-7-2011.
- 4,117,866. **TM CONNECT DESKTOP (STANDARD CHARACTER)**. COMERICA INCORPORATED, (U.S. CLS. 100, 101 AND 102). SN 85-365,369. PUB. 1-10-2012. FILED 7-7-2011.
- 4,117,872. **IB INSURANCE BROWSER AND DESIGN**. INSURANCE BROWSER INC., (U.S. CLS. 100, 101 AND 102). SN 85-365,724. PUB. 1-10-2012. FILED 7-7-2011.
- 4,117,874 (*See Class 35 for this trademark*).
- 4,117,902. **HEALTHY ME! AND DESIGN**. BLUE CROSS & BLUE SHIELD OF MISSISSIPPI, A MUTUAL INSURANCE COMPANY, (U.S. CLS. 100, 101 AND 102). SN 85-367,266. PUB. 1-10-2012. FILED 7-9-2011.
- 4,117,907. **BEER MONEY (STANDARD CHARACTER)**. DARRIN HAYES, (U.S. CLS. 100, 101 AND 102). SN 85-367,782. PUB. 1-10-2012. FILED 7-11-2011.
- 4,117,908. **JAVITS CENTER AND DESIGN**. NEW YORK CONVENTION CENTER OPERATING CORPORATION, MULTIPLE CLASS, (INT. CLS. 36 AND 43), (U.S. CLS. 100, 101 AND 102). SN 85-367,894. PUB. 1-10-2012. FILED 7-11-2011.
- 4,117,914. **PROADVANCED PROTECTION (STANDARD CHARACTER)**. DAL TILE DISTRIBUTION, INC., (U.S. CLS. 100, 101 AND 102). SN 85-368,241. PUB. 1-10-2012. FILED 7-11-2011.
- 4,117,936. **K AND DESIGN**. KINGS CLOTHING INC., (U.S. CLS. 100, 101 AND 102). SN 85-369,095. PUB. 1-10-2012. FILED 7-12-2011.
- 4,117,951 (*See Class 35 for this trademark*).
- 4,117,981. **ROADSENTRY ULTIMATE (STANDARD CHARACTER)**. MOTOR DEALER SERVICES GROUP, LLC, (U.S. CLS. 100, 101 AND 102). SN 85-371,030. PUB. 1-10-2012. FILED 7-14-2011.
- 4,117,990 (*See Class 35 for this trademark*).
- 4,118,001 (*See Class 35 for this trademark*).
- 4,118,002. **LOYA (STANDARD CHARACTER)**. EP LOYA GROUP, LP, (U.S. CLS. 100, 101 AND 102). SN 85-371,853. PUB. 1-10-2012. FILED 7-14-2011.
- 4,118,003. **ALL 4 QUARTERS SPORTS (STYLIZED)**. CLEELAND, CAMERON, (U.S. CLS. 100, 101 AND 102). SN 85-371,855. PUB. 1-10-2012. FILED 7-14-2011.
- 4,118,009. **REAL ESTATE IS ROCK'N & ROLL'N (STANDARD CHARACTER)**. TORI MCKINNEY, LLC, (U.S. CLS. 100, 101 AND 102). SN 85-372,088. PUB. 1-10-2012. FILED 7-15-2011.
- 4,118,022 (*See Class 35 for this trademark*).
- 4,118,040. **STRIVE AND DESIGN**. CHAN, LISA, (U.S. CLS. 100, 101 AND 102). SN 85-373,053. PUB. 1-10-2012. FILED 7-16-2011.
- 4,118,046. **USLI (STYLIZED)**. U.S. INVESTMENT CORP., (U.S. CLS. 100, 101 AND 102). SN 85-373,124. PUB. 1-10-2012. FILED 7-16-2011.
- 4,118,051 (*See Class 24 for this trademark*).
- 4,118,065. **CLIENTS SPEAK (STANDARD CHARACTER)**. CHARLES SCHWAB & CO., INC., (U.S. CLS. 100, 101 AND 102). SN 85-373,666. PUB. 1-10-2012. FILED 7-18-2011.
- 4,118,069. **SHARED VALUES FUND (STANDARD CHARACTER)**. AMERISRAEL CAPITAL MANAGEMENT LLC, AKA SHARED VALUES FUND, (U.S. CLS. 100, 101 AND 102). SN 85-373,687. PUB. 1-10-2012. FILED 7-18-2011.
- 4,118,072. **MISCELLANEOUS DESIGN**. COUNCIL FOR LIFE, (U.S. CLS. 100, 101 AND 102). SN 85-373,812. PUB. 1-10-2012. FILED 7-18-2011.
- 4,118,084. **MVPAY.HUB (STYLIZED)**. MONAVIE LLC, (U.S. CLS. 100, 101 AND 102). SN 85-374,079. PUB. 1-10-2012. FILED 7-18-2011.
- 4,118,124. **BANKCARD SERVICES GOING BEYOND EXPECTATIONS AND DESIGN**. BANKCARD SERVICES, INC., (U.S. CLS. 100, 101 AND 102). SN 85-374,888. PUB. 1-10-2012. FILED 7-19-2011.
- 4,118,135. **ANYWHERE APPOINTMENT (STANDARD CHARACTER)**. NEW MEXICO EDUCATORS FEDERAL CREDIT

- UNION, (U.S. CLS. 100, 101 AND 102). SN 85-375,220. PUB. 1-10-2012. FILED 7-19-2011.
- 4,118,136. **THE TAMPA BAY TRUST COMPANY AND DESIGN.** SANIBEL/CAPTIVA TRUST COMPANY, (U.S. CLS. 100, 101 AND 102). SN 85-375,233. PUB. 1-10-2012. FILED 7-19-2011.
- 4,118,140. **ANYWHERE DEPOSIT (STANDARD CHARACTER).** NEW MEXICO EDUCATORS FEDERAL CREDIT UNION, (U.S. CLS. 100, 101 AND 102). SN 85-375,261. PUB. 1-10-2012. FILED 7-19-2011.
- 4,118,155. **WE SHOP THE STREET (STANDARD CHARACTER).** HIGGINS CAPITAL MANAGEMENT, INC., (U.S. CLS. 100, 101 AND 102). SN 85-375,421. PUB. 1-10-2012. FILED 7-19-2011.
- 4,118,156. **AUTISM SUCKS (STANDARD CHARACTER).** GROWING ROSE'S FOUNDATION, (U.S. CLS. 100, 101 AND 102). SN 85-375,425. PUB. 1-10-2012. FILED 7-19-2011.
- 4,118,177. **BRAINTREE (STANDARD CHARACTER).** BRAINTREE PAYMENT SOLUTIONS, LLC, (U.S. CLS. 100, 101 AND 102). SN 85-375,815. PUB. 1-10-2012. FILED 7-20-2011.
- 4,118,191. **COUNT ON US (STANDARD CHARACTER).** DIRECT FEDERAL CREDIT UNION, (U.S. CLS. 100, 101 AND 102). SN 85-376,359. PUB. 1-10-2012. FILED 7-20-2011.
- 4,118,193. **ALLIED PROTECTOR PLAN (STANDARD CHARACTER).** B&B PROTECTOR PLANS, INC., (U.S. CLS. 100, 101 AND 102). SN 85-376,414. PUB. 1-10-2012. FILED 7-20-2011.
- 4,118,210. **COMMONFUND TREASURY ACCESS (STANDARD CHARACTER).** COMMON FUND FOR NONPROFIT ORGANIZATIONS, THE, (U.S. CLS. 100, 101 AND 102). SN 85-377,257. PUB. 1-10-2012. FILED 7-21-2011.
- 4,118,212. **COMMONFUND CUSTOM INVESTMENT OFFICE (STANDARD CHARACTER).** COMMON FUND FOR NONPROFIT ORGANIZATIONS, THE, (U.S. CLS. 100, 101 AND 102). SN 85-377,318. PUB. 1-10-2012. FILED 7-21-2011.
- 4,118,215. **ZINGENUITY (STANDARD CHARACTER).** ZINGENUITY, INC., MULTIPLE CLASS, (INT. CLS. 36 AND 45), (U.S. CLS. 100, 101 AND 102). SN 85-377,465. PUB. 1-10-2012. FILED 7-21-2011.
- 4,118,217. **ZINGENUITY AND DESIGN.** ZINGENUITY, INC., MULTIPLE CLASS, (INT. CLS. 36 AND 45), (U.S. CLS. 100, 101 AND 102). SN 85-377,501. PUB. 1-10-2012. FILED 7-21-2011.
- 4,118,226 (*See Class 25 for this trademark*).
- 4,118,237. **WATER POINTE REALTY GROUP (STANDARD CHARACTER).** WATER POINTE REALTY GROUP, LLC, (U.S. CLS. 100, 101 AND 102). SN 85-377,969. PUB. 1-10-2012. FILED 7-21-2011.
- 4,118,238. **PADS2HOME REALTY "WE BELIEVE IN A BETTER HOME" 2 AND DESIGN.** PADS 2 HOME REALTY CORPORATION, (U.S. CLS. 100, 101 AND 102). SN 85-378,001. PUB. 1-10-2012. FILED 7-22-2011.
- 4,118,254. **FREEDOM RATIO (STANDARD CHARACTER).** FENTON AND ROSS AN ACCOUNTANCY CORP, (U.S. CLS. 100, 101 AND 102). SN 85-378,953. PUB. 1-10-2012. FILED 7-22-2011.
- 4,118,268. **DALLAS IS LOVE (STANDARD CHARACTER).** DALLAS IS LOVE, (U.S. CLS. 100, 101 AND 102). SN 85-379,899. PUB. 1-10-2012. FILED 7-25-2011.
- 4,118,274. **LIBERTY SERIES ESTATE MAXIMIZER NEXT GENERATION (STANDARD CHARACTER).** LIBERTY MUTUAL INSURANCE COMPANY, (U.S. CLS. 100, 101 AND 102). SN 85-380,101. PUB. 1-10-2012. FILED 7-25-2011.
- 4,118,281. **ROYAL FLUSH REAL ESTATE (STANDARD CHARACTER).** SANCHEZ, GUADALUPE, (U.S. CLS. 100, 101 AND 102). SN 85-380,336. PUB. 1-10-2012. FILED 7-25-2011.
- 4,118,300. **WHEELHOUSE ADVISORS (STANDARD CHARACTER).** LARRY CALLAHAN, (U.S. CLS. 100, 101 AND 102). SN 85-382,403. PUB. 1-10-2012. FILED 7-27-2011.
- 4,118,307. **WATER POINTE REALTY GROUP AND DESIGN.** WATER POINTE REALTY GROUP, LLC, (U.S. CLS. 100, 101 AND 102). SN 85-384,483. PUB. 1-10-2012. FILED 7-29-2011.
- 4,118,336. **ALLEY HOUSE (STANDARD CHARACTER).** THE ALLEY HOUSE, LLC, (U.S. CLS. 100, 101 AND 102). SN 85-388,539. PUB. 1-10-2012. FILED 8-3-2011.
- 4,118,341. **PROSTEAD (STANDARD CHARACTER).** THE MULLER GROUP, INC., DBA PROSTEAD REALTY, (U.S. CLS. 100, 101 AND 102). SN 85-389,040. PUB. 1-10-2012. FILED 8-3-2011.
- 4,118,345. **MERCHANT SERVICES THAT WORK FOR B2B (STANDARD CHARACTER).** NOWACCOUNT NETWORK CORPORATION, MULTIPLE CLASS, (INT. CLS. 36 AND 42), (U.S. CLS. 100, 101 AND 102). SN 85-389,245. PUB. 1-10-2012. FILED 8-4-2011.
- 4,118,346. **NATIONALLY RECOGNIZED, GLOBALLY CONNECTED, LOCALLY ACCESSIBLE (STANDARD CHARACTER).** FINANCIAL NETWORK GROUP, LTD., (U.S. CLS. 100, 101 AND 102). SN 85-389,251. PUB. 1-10-2012. FILED 8-4-2011.
- 4,118,347. **NOWACCOUNT (STANDARD CHARACTER).** NOWACCOUNT NETWORK CORPORATION, MULTIPLE CLASS, (INT. CLS. 36 AND 42), (U.S. CLS. 100, 101 AND 102). SN 85-389,259. PUB. 1-10-2012. FILED 8-4-2011.
- 4,118,354. **WESTERN TECHNOLOGY INVESTMENT (STANDARD CHARACTER).** WESTECH INVESTMENT ADVISORS LLC, (U.S. CLS. 100, 101 AND 102). SN 85-389,976. PUB. 1-10-2012. FILED 8-4-2011.
- 4,118,356. **WESTERN SKY (STANDARD CHARACTER).** WESTERN SKY FINANCIAL, LLC, (U.S. CLS. 100, 101 AND 102). SN 85-389,983. PUB. 1-10-2012. FILED 8-4-2011.
- 4,118,496. **WBI (STANDARD CHARACTER).** WBI INVESTMENTS, INC., (U.S. CLS. 100, 101 AND 102). SN 85-394,073. PUB. 1-10-2012. FILED 8-10-2011.
- 4,118,517. **MISCELLANEOUS DESIGN.** AQUA CAPITAL MANAGEMENT LP, (U.S. CLS. 100, 101 AND 102). SN 85-394,538. PUB. 1-10-2012. FILED 8-10-2011.
- 4,118,523. **WE EMPOWER YOU (STANDARD CHARACTER).** MCGUIRE PERFORMANCE SOLUTIONS, INC., (U.S. CLS. 100, 101 AND 102). SN 85-394,797. PUB. 1-10-2012. FILED 8-10-2011.
- 4,118,529. **CURADEBT (STANDARD CHARACTER).** CURADEBT SYSTEMS, LLC, (U.S. CLS. 100, 101 AND 102). SN 85-394,862. PUB. 1-10-2012. FILED 8-10-2011.
- 4,118,586. **\$10 OF HOPE (STANDARD CHARACTER).** CATON, RICHARD, (U.S. CLS. 100, 101 AND 102). SN 85-395,878. PUB. 1-10-2012. FILED 8-11-2011.
- 4,118,640. **VIRTUALLY EVERYWHERE (STANDARD CHARACTER).** CALIFORNIA CAPITAL INSURANCE COMPANY, DBA CAPITAL INSURANCE GROUP, (U.S. CLS. 100, 101 AND 102). SN 85-397,041. PUB. 1-10-2012. FILED 8-12-2011.
- 4,118,643. **BG AND DESIGN.** AMERICAN LIBERTY BAIL BONDS, INC., (U.S. CLS. 100, 101 AND 102). SN 85-397,054. PUB. 1-10-2012. FILED 8-12-2011.
- 4,118,647. **1-800-BAIL-GUY (STANDARD CHARACTER).** AMERICAN LIBERTY BAIL BONDS, INC., (U.S. CLS. 100, 101 AND 102). SN 85-397,108. PUB. 1-10-2012. FILED 8-12-2011.
- 4,118,652. **MISCELLANEOUS DESIGN.** OBS FINANCIAL SERVICES, INC., (U.S. CLS. 100, 101 AND 102). SN 85-397,195. PUB. 1-10-2012. FILED 8-12-2011.
- 4,118,679. **WORLDQUANT AND DESIGN.** WORLDQUANT, LLC, (U.S. CLS. 100, 101 AND 102). SN 85-404,814. PUB. 1-10-2012. FILED 8-23-2011.
- 4,118,682. **EP FEDERAL CREDIT UNION AND DESIGN.** EP FEDERAL CREDIT UNION, (U.S. CLS. 100, 101 AND 102). SN 85-406,755. PUB. 1-10-2012. FILED 8-25-2011.
- 4,118,693. **M POWER YOUR ACCOUNT YOUR WAY! AND DESIGN.** REDSTONE FEDERAL CREDIT UNION, (U.S. CLS. 100, 101 AND 102). SN 85-417,372. PUB. 1-10-2012. FILED 9-8-2011.
- 4,118,694. **MPOWER (STANDARD CHARACTER).** REDSTONE FEDERAL CREDIT UNION, (U.S. CLS. 100, 101 AND 102). SN 85-417,374. PUB. 1-10-2012. FILED 9-8-2011.
- 4,118,703. **POINT. CLICK. HELP ERADICATE POVERTY. (STANDARD CHARACTER).** GIVELOCALLY LLC, (U.S. CLS. 100, 101 AND 102). SN 85-426,260. PUB. 1-10-2012. FILED 9-19-2011.
- 4,118,704. **ARCH CANOPY FOR INVESTMENT ADVISERS AND INVESTMENT COMPANIES (STANDARD CHARACTER).** ARCH CAPITAL GROUP (U.S.) INC., (U.S. CLS. 100, 101 AND 102). SN 85-426,934. PUB. 1-10-2012. FILED 9-20-2011.

CLASS 37—CONSTRUCTION AND REPAIR

- 4,116,558. **AUTOCLAVE ENGINEERS AND DESIGN. SNAP-TITE TECHNOLOGIES, INC.**, (U.S. CLS. 100, 103 AND 106). SN 76-701,603. PUB. 1-10-2012. FILED 2-16-2010.
- 4,116,594 (*See Class 19 for this trademark.*)
- 4,116,611 (*See Class 9 for this trademark.*)
- 4,116,678 (*See Class 1 for this trademark.*)
- 4,116,682 (*See Class 7 for this trademark.*)
- 4,116,688 (*See Class 7 for this trademark.*)
- 4,116,689. **RED CARPET PARIS AND DESIGN. CLAIRE VIDAL**, (U.S. CLS. 100, 103 AND 106). SN 79-082,663. PUB. 1-10-2012. FILED 4-14-2010.
- 4,116,736 (*See Class 9 for this trademark.*)
- 4,116,761 (*See Class 7 for this trademark.*)
- 4,116,774 (*See Class 7 for this trademark.*)
- 4,116,819 (*See Class 7 for this trademark.*)
- 4,116,847 (*See Class 25 for this trademark.*)
- 4,116,877 (*See Class 9 for this trademark.*)
- 4,116,884 (*See Class 9 for this trademark.*)
- 4,116,891 (*See Class 36 for this trademark.*)
- 4,116,899. **ROOFING REMEDIES AND DESIGN. NIX, CLYDE**, (U.S. CLS. 100, 103 AND 106). SN 85-070,309. PUB. 1-10-2012. FILED 6-24-2010.
- 4,116,919. **TWIN METALS (STANDARD CHARACTER). ANTOFAGASTA MINERALS S.A.**, (U.S. CLS. 100, 103 AND 106). SN 85-094,227. PUB. 1-10-2012. FILED 7-27-2010.
- 4,116,982 (*See Class 36 for this trademark.*)
- 4,117,032 (*See Class 9 for this trademark.*)
- 4,117,051. **BEST QUALITY. BEST WAY. BEST PRICE. (STANDARD CHARACTER). ROTONDO WEIRICH ENTERPRISES, INC.**, (U.S. CLS. 100, 103 AND 106). SN 85-216,649. PUB. 1-10-2012. FILED 1-13-2011.
- 4,117,064 (*See Class 36 for this trademark.*)
- 4,117,068. **NEXUS ENERGYHOMES (STANDARD CHARACTER). NEXUS ENERGYHOMES, INC.**, (U.S. CLS. 100, 103 AND 106). SN 85-220,808. PUB. 1-10-2012. FILED 1-19-2011.
- 4,117,081 (*See Class 17 for this trademark.*)
- 4,117,153. **BOSS DISASTER RESTORATION (STANDARD CHARACTER). BOSS DISASTER RESTORATION, INC.**, (U.S. CLS. 100, 103 AND 106). SN 85-234,365. PUB. 1-10-2012. FILED 2-4-2011.
- 4,117,157. **ALL PURPOSE PLUMBING AND DESIGN. ALL PURPOSE PLUMBING LLC**, (U.S. CLS. 100, 103 AND 106). SN 85-234,897. PUB. 1-10-2012. FILED 2-4-2011.
- 4,117,226. **GIMME 5 (STANDARD CHARACTER). RECYCLINE, INC.**, (U.S. CLS. 100, 103 AND 106). SN 85-245,580. PUB. 1-10-2012. FILED 2-18-2011.
- 4,117,250. **PLANET AUTO WASH AND DESIGN. PLANET AUTO WASH, LLC**, (U.S. CLS. 100, 103 AND 106). SN 85-249,146. PUB. 1-10-2012. FILED 2-23-2011.
- 4,117,261. **CVM AND DESIGN. CVM AFFILIATES, INC.**, MULTIPLE CLASS, (INT. CLS. 37 AND 42), (U.S. CLS. 100, 101, 103 AND 106). SN 85-251,720. PUB. 1-10-2012. FILED 2-25-2011.
- 4,117,319. **PLUG & PROTECT (STANDARD CHARACTER). BOLSTER LLC**, (U.S. CLS. 100, 103 AND 106). SN 85-264,917. PUB. 1-10-2012. FILED 3-11-2011.
- 4,117,523. **PRO-1 CONSTRUCTION (STANDARD CHARACTER). PRO-1 CONSTRUCTION SERVICES CO., DBA PRO-1 CONSTRUCTION**, (U.S. CLS. 100, 103 AND 106). SN 85-306,715. PUB. 1-10-2012. FILED 4-27-2011.
- 4,117,600 (*See Class 7 for this trademark.*)
- 4,117,629. **GRIFFITH ENERGY SERVICES, INC. DOGGONE DEPENDABLE AND DESIGN. GRIFFITH ENERGY SERVICES, INC.**, (U.S. CLS. 100, 103 AND 106). SN 85-329,173. PUB. 1-10-2012. FILED 5-24-2011.
- 4,117,631. **MISCELLANEOUS DESIGN. AQUATIC FEATURES, INC.**, (U.S. CLS. 100, 103 AND 106). SN 85-329,760. PUB. 1-10-2012. FILED 5-25-2011.
- 4,117,632. **RENT A MENSCH (STANDARD CHARACTER). LEVINE, MICHAEL B. DBA RENTAMENSCH**, (U.S. CLS. 100, 103 AND 106). SN 85-330,108. PUB. 1-10-2012. FILED 5-25-2011.
- 4,117,690. **I WANT MY CAR TOTALED (STANDARD CHARACTER). BEST LANE ENTERPRISES, INC.**, (U.S. CLS. 100, 103 AND 106). SN 85-342,021. PUB. 1-10-2012. FILED 6-9-2011.
- 4,117,716. **ARNOLD'S HOME IMPROVEMENT AND DESIGN. ARNOLD'S HOME IMPROVEMENT**, (U.S. CLS. 100, 103 AND 106). SN 85-347,037. PUB. 1-10-2012. FILED 6-15-2011.
- 4,117,832. **A COMPUTER MD, INC. (STANDARD CHARACTER). FOWLER, STEVEN W. DBA A COMPUTER MD, INC.**, (U.S. CLS. 100, 103 AND 106). SN 85-362,059. PUB. 1-10-2012. FILED 7-1-2011.
- 4,117,867. **C AND DESIGN. CHAMPION WINDOW MANUFACTURING AND SUPPLY CO., LLC**, (U.S. CLS. 100, 103 AND 106). SN 85-365,371. PUB. 1-10-2012. FILED 7-7-2011.
- 4,117,889. **JACK RABBIT USA, LLC YOUR ROADSIDE ASSISTANCE PROFESSIONALS AND DESIGN. JACK RABBIT USA, LLC**, (U.S. CLS. 100, 103 AND 106). SN 85-366,566. PUB. 1-10-2012. FILED 7-8-2011.
- 4,117,896. **CLEANING POLICE AND DESIGN. CLEANING POLICE LLC**, (U.S. CLS. 100, 103 AND 106). SN 85-366,945. PUB. 1-10-2012. FILED 7-8-2011.
- 4,117,916. **TERMITE TIGER AND DESIGN. ROYAL PEST CONTROL INC.**, (U.S. CLS. 100, 103 AND 106). SN 85-368,329. PUB. 1-10-2012. FILED 7-11-2011.
- 4,117,922 (*See Class 35 for this trademark.*)
- 4,117,959. **CITITURF (STANDARD CHARACTER). CITITURF, LLC. MULTIPLE CLASS, (INT. CLS. 37 AND 44)**, (U.S. CLS. 100, 101, 103 AND 106). SN 85-370,341. PUB. 1-10-2012. FILED 7-13-2011.
- 4,117,979. **MISCELLANEOUS DESIGN. INA ACQUISITION CORP.**, (U.S. CLS. 100, 103 AND 106). SN 85-370,988. PUB. 1-10-2012. FILED 7-14-2011.
- 4,117,986 (*See Class 35 for this trademark.*)
- 4,117,988. **WISEGUY CLEANERS HOME & OFFICE CLEANING SERVICES TOUGH DIRT, TOP DOG! AND DESIGN. WISEGUY CLEANERS LLC**, (U.S. CLS. 100, 103 AND 106). SN 85-371,262. PUB. 1-10-2012. FILED 7-14-2011.
- 4,118,017. **POWERCLUB (STANDARD CHARACTER). CLOCKWORK IP, LLC**, (U.S. CLS. 100, 103 AND 106). SN 85-372,316. PUB. 1-10-2012. FILED 7-15-2011.
- 4,118,023. **CARTER BRUCE LLC HOMEBUILDER (STANDARD CHARACTER). CARTER BRUCE LLC**, (U.S. CLS. 100, 103 AND 106). SN 85-372,544. PUB. 1-10-2012. FILED 7-15-2011.
- 4,118,048. **J.E.P. CONTRACTING CUSTOM HOMES & ADDITIONS "PUT YOUR HOME IN OUR HANDS" AND DESIGN. J.E.P. CONTRACTING, INC.**, (U.S. CLS. 100, 103 AND 106). SN 85-373,206. PUB. 1-10-2012. FILED 7-16-2011.
- 4,118,052. **ROYAL BLUE (STANDARD CHARACTER). ROYAL BLUE SERVICES LLC**, (U.S. CLS. 100, 103 AND 106). SN 85-373,469. PUB. 1-10-2012. FILED 7-18-2011.
- 4,118,078. **GEHAN HOMES (STANDARD CHARACTER). GEHAN HOMES, LTD.**, (U.S. CLS. 100, 103 AND 106). SN 85-373,889. PUB. 1-10-2012. FILED 7-18-2011.
- 4,118,096. **RANGER PLUMBING AND HEATING AND DESIGN. RANGER PLUMBING & HEATING INC.**, (U.S. CLS. 100, 103 AND 106). SN 85-374,283. PUB. 1-10-2012. FILED 7-18-2011.
- 4,118,109 (*See Class 30 for this trademark.*)
- 4,118,127. **SPOT OFF SERVICES (STANDARD CHARACTER). PRO QUALITY CLEANING, LLC**, (U.S. CLS. 100, 103 AND 106). SN 85-374,975. PUB. 1-10-2012. FILED 7-19-2011.
- 4,118,184. **TRANS AMERICAN MUSCLE (STANDARD CHARACTER). TRANS AMERICAN MUSCLE, LLC**, (U.S. CLS. 100, 103 AND 106). SN 85-376,128. PUB. 1-10-2012. FILED 7-20-2011.
- 4,118,192 (*See Class 35 for this trademark.*)
- 4,118,203. **IT AND DESIGN. INTEGRATECHS, INC., MULTIPLE CLASS, (INT. CLS. 37 AND 42)**, (U.S. CLS. 100, 101, 103 AND 106). SN 85-376,822. PUB. 1-10-2012. FILED 7-20-2011.
- 4,118,204. **INTEGRATECHS (STANDARD CHARACTER). INTEGRATECHS, INC., MULTIPLE CLASS, (INT. CLS. 37 AND 42)**, (U.S. CLS. 100, 101, 103 AND 106). SN 85-376,826. PUB. 1-10-2012. FILED 7-20-2011.
- 4,118,208. **PSW HOMES (STANDARD CHARACTER). PSW HOMES, LLC, DBA PSW HOMES**, (U.S. CLS. 100, 103 AND 106). SN 85-377,163. PUB. 1-10-2012. FILED 7-21-2011.
- 4,118,233. **TRAC ASSIST (STANDARD CHARACTER). INTERPOOL, INC.**, (U.S. CLS. 100, 103 AND 106). SN 85-377,829. PUB. 1-10-2012. FILED 7-21-2011.
- 4,118,330. **PRO VIEW (STANDARD CHARACTER). PRO VIEW WINDOWS, INC.**, (U.S. CLS. 100, 103 AND 106). SN 85-388,152. PUB. 1-10-2012. FILED 8-3-2011.

- 4,118,459. **CONDITIONEER (STANDARD CHARACTER)**. SUPERB MECHANICAL SERVICES, INC., (U.S. CLS. 100, 103 AND 106). SN 85-393,358. PUB. 1-10-2012. FILED 8-9-2011.
- 4,118,492. **GOOD NEIGHBORS BUILDING GREAT NEIGHBORHOODS. (STANDARD CHARACTER)**. MARRICK PROPERTIES, INC., (U.S. CLS. 100, 103 AND 106). SN 85-394,008. PUB. 1-10-2012. FILED 8-10-2011.
- 4,118,515. **ALL AMERICAN CARBURETORS (STANDARD CHARACTER)**. WELDON ENTERPRISES, INC., DBA ALL AMERICAN CARBURETORS, (U.S. CLS. 100, 103 AND 106). SN 85-394,529. PUB. 1-10-2012. FILED 8-10-2011.
- 4,118,522. **1ST LIGHT ENERGY (STANDARD CHARACTER)**. 1ST LIGHT ENERGY, INC., (U.S. CLS. 100, 103 AND 106). SN 85-394,786. PUB. 1-10-2012. FILED 8-10-2011.
- 4,118,562. **TH AND DESIGN. TH REMODELING & RENOVATIONS, INC.**, (U.S. CLS. 100, 103 AND 106). SN 85-395,457. PUB. 1-10-2012. FILED 8-11-2011.
- 4,118,745 (*See Class 4 for this trademark*).

CLASS 38—COMMUNICATION

- 4,116,550. **NOW NETWORK**. SPRINT COMMUNICATIONS COMPANY L.P., (U.S. CLS. 100, 101 AND 104). SN 75-955,972. PUB. 8-9-2011. FILED 3-10-2000.
- 4,116,612 (*See Class 35 for this trademark*).
- 4,116,650 (*See Class 7 for this trademark*).
- 4,116,651 (*See Class 7 for this trademark*).
- 4,116,652 (*See Class 7 for this trademark*).
- 4,116,653 (*See Class 7 for this trademark*).
- 4,116,679 (*See Class 9 for this trademark*).
- 4,116,681 (*See Class 9 for this trademark*).
- 4,116,688 (*See Class 7 for this trademark*).
- 4,116,697 (*See Class 9 for this trademark*).
- 4,116,724 (*See Class 9 for this trademark*).
- 4,116,735 (*See Class 5 for this trademark*).
- 4,116,761 (*See Class 7 for this trademark*).
- 4,116,765 (*See Class 9 for this trademark*).
- 4,116,776 (*See Class 35 for this trademark*).
- 4,116,853 (*See Class 9 for this trademark*).
- 4,116,877 (*See Class 9 for this trademark*).
- 4,116,878 (*See Class 35 for this trademark*).
- 4,116,982 (*See Class 36 for this trademark*).
- 4,117,006. **MUSL TV AND DESIGN**. MUSL TV, LLC, MULTIPLE CLASS, (INT. CLS. 38 AND 41), (U.S. CLS. 100, 101, 104 AND 107). SN 85-192,726. PUB. 1-10-2012. FILED S.R. 12-7-2010; AM. P.R. 11-17-2011.
- 4,117,027. **MYTX (STANDARD CHARACTER)**. LONDON BROADCASTING COMPANY, INC., (U.S. CLS. 100, 101 AND 104). SN 85-203,067. PUB. 1-10-2012. FILED 12-21-2010.
- 4,117,042 (*See Class 35 for this trademark*).
- 4,117,099 (*See Class 35 for this trademark*).
- 4,117,233 (*See Class 9 for this trademark*).
- 4,117,249. **INSIDE FOOD (STANDARD CHARACTER)**. HOSCHLER, STEPHEN, (U.S. CLS. 100, 101 AND 104). SN 85-248,941. PUB. 1-10-2012. FILED 2-22-2011.
- 4,117,259 (*See Class 9 for this trademark*).
- 4,117,286. **GUY SPY AND DESIGN**. PAGE ONE VENTURES, LTD., (U.S. CLS. 100, 101 AND 104). SN 85-258,621. PUB. 1-10-2012. FILED 3-4-2011.
- 4,117,324. **DATECAM (STANDARD CHARACTER)**. MACK-WORTH INTERNATIONAL LTD., MULTIPLE CLASS, (INT. CLS. 38, 41 AND 45), (U.S. CLS. 100, 101, 104 AND 107). SN 85-266,892. PUB. 1-10-2012. FILED 3-15-2011.
- 4,117,417. **SOCIAL MEDIA DJ (STANDARD CHARACTER)**. METHODSHOP, LLC, (U.S. CLS. 100, 101 AND 104). SN 85-286,175. PUB. 1-10-2012. FILED 4-5-2011.
- 4,117,418. **SOCIAL DJ (STANDARD CHARACTER)**. METHODSHOP, LLC, (U.S. CLS. 100, 101 AND 104). SN 85-286,185. PUB. 1-10-2012. FILED 4-5-2011.
- 4,117,463. **DIRECT FROM HOLLYWOOD (STANDARD CHARACTER)**. PREMIERE RADIO NETWORKS, INC., MULTIPLE CLASS, (INT. CLS. 38 AND 41), (U.S. CLS. 100, 101, 104 AND 107). SN 85-294,854. PUB. 1-10-2012. FILED 4-14-2011.
- 4,117,513. **TROOPLA (STANDARD CHARACTER)**. QUICK CATCH LABS LLC, (U.S. CLS. 100, 101 AND 104). SN 85-304,118. PUB. 1-10-2012. FILED 4-25-2011.
- 4,117,532. **NOANET NETWORK COORDINATED SERVICES AND DESIGN**. NORTHWEST OPEN ACCESS NETWORK, (U.S. CLS. 100, 101 AND 104). SN 85-308,780. PUB. 1-10-2012. FILED 4-29-2011.
- 4,117,551 (*See Class 9 for this trademark*).
- 4,117,712. **APPDROP (STANDARD CHARACTER)**. SOCIALIZE, INC., (U.S. CLS. 100, 101 AND 104). SN 85-346,737. PUB. 1-10-2012. FILED 6-15-2011.
- 4,117,726. **SHE'S ONLY ROCK 'N ROLL (STANDARD CHARACTER)**. WSHE, (U.S. CLS. 100, 101 AND 104). SN 85-348,677. PUB. 1-10-2012. FILED 6-17-2011.
- 4,117,732. **FULLCHANNEL AND DESIGN**. FULL CHANNEL TV, INC., DBA FULL CHANNEL, (U.S. CLS. 100, 101 AND 104). SN 85-349,616. PUB. 1-10-2012. FILED 6-17-2011.
- 4,117,748. **EASY EVERYDAY COOKING (STANDARD CHARACTER)**. INTERNATIONAL MASTERS PUBLISHERS AB, (U.S. CLS. 100, 101 AND 104). SN 85-351,673. PUB. 1-10-2012. FILED 6-21-2011.
- 4,117,859 (*See Class 35 for this trademark*).
- 4,117,919. **CHEF NETWORK (STANDARD CHARACTER)**. NEW YORK LINK, INC., (U.S. CLS. 100, 101 AND 104). SN 85-368,439. PUB. 1-10-2012. FILED 7-11-2011.
- 4,118,117. **FASTNOTE AND DESIGN**. FASTNOTE, LLC, MULTIPLE CLASS, (INT. CLS. 38 AND 45), (U.S. CLS. 100, 101 AND 104). SN 85-374,735. PUB. 1-10-2012. FILED 7-19-2011.
- 4,118,141. **DIGITAL HIGHWAY (STANDARD CHARACTER)**. DIGITAL HIGHWAY, INC., (U.S. CLS. 100, 101 AND 104). SN 85-375,268. PUB. 1-10-2012. FILED 7-19-2011.
- 4,118,183. **HELIX COMPUTER SYSTEMS AND DESIGN**. HELIX COMPUTER SYSTEMS, INC., DBA HELIX COMPUTER SYSTEMS, MULTIPLE CLASS, (INT. CLS. 38 AND 42), (U.S. CLS. 100, 101 AND 104). SN 85-376,029. PUB. 1-10-2012. FILED 7-20-2011.
- 4,118,289. **INSP IT'S A NEW DAY. AND DESIGN**. THE INSPIRATIONAL NETWORK, INC., (U.S. CLS. 100, 101 AND 104). SN 85-380,659. PUB. 1-10-2012. FILED 7-26-2011.
- 4,118,379 (*See Class 35 for this trademark*).
- 4,118,382. **DIABETEXT (STANDARD CHARACTER)**. POWELL, JAY H, DBA AUCET TECHNOLOGIES, (U.S. CLS. 100, 101 AND 104). SN 85-391,620. PUB. 1-10-2012. FILED 8-7-2011.
- 4,118,390 (*See Class 35 for this trademark*).
- 4,118,521 (*See Class 35 for this trademark*).
- 4,118,552. **REMINISME AND DESIGN**. REMINISME, LLC, (U.S. CLS. 100, 101 AND 104). SN 85-395,312. PUB. 1-10-2012. FILED 8-11-2011.
- 4,118,570. **MISCELLANEOUS DESIGN**. REVISION3 CORPORATION, MULTIPLE CLASS, (INT. CLS. 38 AND 41), (U.S. CLS. 100, 101, 104 AND 107). SN 85-395,698. PUB. 1-10-2012. FILED 8-11-2011.
- 4,118,583. **UMGF (STANDARD CHARACTER)**. UNOFFICIAL MARTIN GUITAR FORUM, A NEW JERSEY NONPROFIT CORPORATION, (U.S. CLS. 100, 101 AND 104). SN 85-395,852. PUB. 1-10-2012. FILED 8-11-2011.
- 4,118,641 (*See Class 9 for this trademark*).
- 4,118,646. **HELLO (STANDARD CHARACTER)**. HEELLO, INC., (U.S. CLS. 100, 101 AND 104). SN 85-397,080. PUB. 1-10-2012. FILED 8-12-2011.
- 4,118,660. **NEXTGENVPN (STANDARD CHARACTER)**. VPN NETSERVICES, LLC., DBA NETSERVICES, LLC., (U.S. CLS. 100, 101 AND 104). SN 85-397,284. PUB. 1-10-2012. FILED 8-13-2011.

CLASS 39—TRANSPORTATION AND STORAGE

- 4,116,589 (*See Class 35 for this trademark*).
- 4,116,607 (*See Class 35 for this trademark*).
- 4,116,608 (*See Class 36 for this trademark*).
- 4,116,636 (*See Class 9 for this trademark*).
- 4,116,679 (*See Class 9 for this trademark*).
- 4,116,736 (*See Class 9 for this trademark*).
- 4,116,761 (*See Class 7 for this trademark*).
- 4,116,767 (*See Class 16 for this trademark*).

4,116,776 (*See Class 35 for this trademark*).
 4,116,806. **LOCALNOMAD (STANDARD CHARACTER)**. MARIEN CAPITAL, S.L., MULTIPLE CLASS, (INT. CLS. 39 AND 43), (U.S. CLS. 100, 101 AND 105). SN 79-098,901. PUB. 1-10-2012. FILED 5-10-2011.
 4,116,843 (*See Class 6 for this trademark*).
 4,116,884 (*See Class 9 for this trademark*).
 4,116,896. **VÍA PRÍMO (STYLIZED)**. VIA METROPOLITAN TRANSIT AUTHORITY AND VIA ADVANCED TRANSPORTATION DISTRICT, (U.S. CLS. 100 AND 105). SN 85-066,801. PUB. 1-10-2012. FILED 6-18-2010.
 4,117,040. **MR. MOVER APARTMENT, HOME AND OFFICE MOVING & STORAGE AND DESIGN**. MR. MOVER, LLC, (U.S. CLS. 100 AND 105). SN 85-210,174. PUB. 1-10-2012. FILED 1-4-2011.
 4,117,055. **CSC AND DESIGN**. COMPUTER SCIENCES CORPORATION, (U.S. CLS. 100 AND 105). SN 85-217,368. PUB. 1-10-2012. FILED 1-13-2011.
 4,117,063 (*See Class 35 for this trademark*).
 4,117,133. **WWW. SOUTHAMERICA.TRAVEL OUR NAME IS OUR PASSION... AND DESIGN**. SOUTHAMERICA.TRAVEL LLC, (U.S. CLS. 100 AND 105). SN 85-231,989. PUB. 1-10-2012. FILED 2-2-2011.
 4,117,267 (*See Class 35 for this trademark*).
 4,117,284 (*See Class 36 for this trademark*).
 4,117,327. **OMNI PARK AND DESIGN**. IMPREZZIO, INC., (U.S. CLS. 100 AND 105). SN 85-267,195. PUB. 1-10-2012. FILED 3-15-2011.
 4,117,356 (*See Class 35 for this trademark*).
 4,117,384 (*See Class 35 for this trademark*).
 4,117,440. **AEROMEXICO CARGO AND DESIGN**. GRUPO AEROMEXICO, S.A. DE C.V., (U.S. CLS. 100 AND 105). SN 85-291,571. PUB. 1-10-2012. FILED 4-11-2011.
 4,117,476 (*See Class 35 for this trademark*).
 4,117,542. **LEASEBYTEL (STANDARD CHARACTER)**. LEASEFAX, LLC, (U.S. CLS. 100 AND 105). SN 85-311,157. PUB. 1-10-2012. FILED 5-3-2011.
 4,117,543. **LAS VEGAS EXOTIC CAR RENTALS (STANDARD CHARACTER)**. LAS VEGAS EXOTIC CAR RENTALS LLC, (U.S. CLS. 100 AND 105). SN 85-311,317. PUB. 1-10-2012. FILED 5-3-2011.
 4,117,564. **LEASEFAX (STANDARD CHARACTER)**. LEASEFAX, LLC, (U.S. CLS. 100 AND 105). SN 85-317,699. PUB. 1-10-2012. FILED 5-11-2011.
 4,117,613 (*See Class 35 for this trademark*).
 4,117,700. **BLACK AND GOLD SERVICE GUARANTEED AND EXPEDITED TRANSPORTATION SERVICES AND DESIGN**. NEBRASKA TRANSPORT COMPANY INC., (U.S. CLS. 100 AND 105). SN 85-344,379. PUB. 1-10-2012. FILED 6-13-2011.
 4,117,782 (*See Class 35 for this trademark*).
 4,117,785. **MISCELLANEOUS DESIGN**. LAWSON, ROBERT W., DBA VINOVERITASWINECLUB.COM, (U.S. CLS. 100 AND 105). SN 85-356,319. PUB. 1-10-2012. FILED 6-25-2011.
 4,117,900. **THE JUNK REMOVERS BIG JIM WWW.THEJUNKREMOVERS.COM AND DESIGN**. THE JUNK REMOVERS, INC., (U.S. CLS. 100 AND 105). SN 85-367,205. PUB. 1-10-2012. FILED 7-9-2011.
 4,117,990 (*See Class 35 for this trademark*).
 4,118,151 (*See Class 35 for this trademark*).
 4,118,181. **OA CARGO, INC. (STYLIZED)**. O. A. CARGO INC., (U.S. CLS. 100 AND 105). SN 85-375,921. PUB. 1-10-2012. FILED 7-20-2011.
 4,118,240. **THE VILLAGES MOVING SERVICE (STANDARD CHARACTER)**. MOVE PROS LLC, DBA THE VILLAGES MOVING SERVICE, (U.S. CLS. 100 AND 105). SN 85-378,139. PUB. 1-10-2012. FILED 7-22-2011.
 4,118,431. **FASTPATH (STANDARD CHARACTER)**. US AIRWAYS, INC., (U.S. CLS. 100 AND 105). SN 85-392,940. PUB. 1-10-2012. FILED 8-9-2011.
 4,118,466. **SECURE TRANSPORTATION (STANDARD CHARACTER)**. SECURE TRANSPORTATION COMPANY, INC., (U.S. CLS. 100 AND 105). SN 85-393,428. PUB. 1-10-2012. FILED 8-9-2011.
 4,118,609. **RV STORAGE DEPOT AND DESIGN**. RAMSER, PHILIP, (U.S. CLS. 100 AND 105). SN 85-396,471. PUB. 1-10-2012. FILED 8-12-2011.
 4,118,662. **HOMOBILES (STANDARD CHARACTER)**. BREE-

DLOVE, LYNN, (U.S. CLS. 100 AND 105). SN 85-397,379. PUB. 1-10-2012. FILED 8-13-2011.
 4,118,686 (*See Class 35 for this trademark*).
 4,118,689 (*See Class 35 for this trademark*).
 4,118,745 (*See Class 4 for this trademark*).

CLASS 40—MATERIAL TREATMENT

4,116,670 (*See Class 1 for this trademark*).
 4,116,678 (*See Class 1 for this trademark*).
 4,116,761 (*See Class 7 for this trademark*).
 4,116,818 (*See Class 6 for this trademark*).
 4,116,884 (*See Class 9 for this trademark*).
 4,116,946 (*See Class 35 for this trademark*).
 4,116,997 (*See Class 10 for this trademark*).
 4,117,043. **ELECTRIC POWERTRAIN ADVANTAGE (STANDARD CHARACTER)**. GES ELECTRIC AERO CORPORATION, MULTIPLE CLASS, (INT. CLS. 40 AND 42), (U.S. CLS. 100, 101, 103 AND 106). SN 85-211,360. PUB. 1-10-2012. FILED 1-5-2011.
 4,117,088. **TRAFFIC GRAPHIX (STANDARD CHARACTER)**. DUCKLOW, CHARLES, (U.S. CLS. 100, 103 AND 106). SN 85-223,742. PUB. 1-10-2012. FILED 1-21-2011.
 4,117,099 (*See Class 35 for this trademark*).
 4,117,368 (*See Class 35 for this trademark*).
 4,117,373. **FREE FLOW CREATIONS (STANDARD CHARACTER)**. GORMAN, ANDREW J., DBA FREE FLOW CREATIONS, (U.S. CLS. 100, 103 AND 106). SN 85-277,929. PUB. 1-10-2012. FILED 3-26-2011.
 4,117,472. **CALPIPE INDUSTRIES (STANDARD CHARACTER)**. CALPIPE INDUSTRIES, (U.S. CLS. 100, 103 AND 106). SN 85-296,613. PUB. 1-10-2012. FILED 4-15-2011.
 4,117,498. **APEX WATERJETTING TECHNOLOGIES AND DESIGN**. APEX WATERJETTING TECHNOLOGIES, INC., (U.S. CLS. 100, 103 AND 106). SN 85-301,724. PUB. 1-10-2012. FILED 4-21-2011.
 4,117,639 (*See Class 35 for this trademark*).
 4,117,642. **AMERICAN GRATING AND DESIGN**. AMERICAN GRATING, LLC, (U.S. CLS. 100, 103 AND 106). SN 85-332,688. PUB. 1-10-2012. FILED 5-27-2011.
 4,117,670 (*See Class 30 for this trademark*).
 4,117,743. **ART AND FRAME OF FALLS CHURCH AND DESIGN**. ART AND FRAME OF FALLS CHURCH, LLC, (U.S. CLS. 100, 103 AND 106). SN 85-351,256. PUB. 1-10-2012. FILED 6-21-2011.
 4,117,744. **MAKE LIFE WORTH FRAMING! (STANDARD CHARACTER)**. ART AND FRAME OF FALLS CHURCH, LLC, (U.S. CLS. 100, 103 AND 106). SN 85-351,263. PUB. 1-10-2012. FILED 6-21-2011.
 4,117,795. **OLSON ALUMINUM CASTINGS AND DESIGN**. OLSON ALUMINUM CASTING, LTD., (U.S. CLS. 100, 103 AND 106). SN 85-357,762. PUB. 1-10-2012. FILED 6-28-2011.
 4,117,803. **PACIFICVIAL AND DESIGN**. PACIFIC VIAL MFG. INC., (U.S. CLS. 100, 103 AND 106). SN 85-358,904. PUB. 1-10-2012. FILED 6-28-2011.
 4,117,841. **FOREVERBEAD (STANDARD CHARACTER)**. STEEL-JONES, JOAN, (U.S. CLS. 100, 103 AND 106). SN 85-363,119. PUB. 1-10-2012. FILED 7-5-2011.
 4,117,974. **PROMARK AND DESIGN**. METRO INDUSTRIES LLC, DBA ELLIOTT BAY INDUSTRIES, (U.S. CLS. 100, 103 AND 106). SN 85-370,861. PUB. 1-10-2012. FILED 7-13-2011.
 4,118,073. **U GOT STINK? THE TRUE ODOR ELIMINATORS AND DESIGN**. U GOT STINK FRANCHISING, LLC, (U.S. CLS. 100, 103 AND 106). SN 85-373,821. PUB. 1-10-2012. FILED 7-18-2011.
 4,118,227. **THE WESTERNER SILVER SHOP AND DESIGN**. THE WESTERNER SILVER SHOP AND TROPHY CENTER, INC., (U.S. CLS. 100, 103 AND 106). SN 85-377,732. PUB. 1-10-2012. FILED 7-21-2011.
 4,118,367. **MISCELLANEOUS DESIGN**. KJR SECURITY, LLC, MULTIPLE CLASS, (INT. CLS. 40 AND 45), (U.S. CLS. 100, 101, 103 AND 106). SN 85-390,500. PUB. 1-10-2012. FILED 8-5-2011.
 4,118,390 (*See Class 35 for this trademark*).
 4,118,418. **MISCELLANEOUS DESIGN**. GARDNER, BRIAN D., DBA BDG CUSTOMS, (U.S. CLS. 100, 103 AND 106). SN

- 85-392,641. PUB. 1-10-2012. FILED 8-8-2011.
 4,118,511 (*See Class 16 for this trademark*).
 4,118,597. **EARTHSMART (STANDARD CHARACTER)**. RADER, THEODORE W. (U.S. CLS. 100, 103 AND 106). SN 85-396,073. PUB. 1-10-2012. FILED 8-11-2011.
 4,118,607 (*See Class 30 for this trademark*).

CLASS 41—EDUCATION AND ENTERTAINMENT

- 4,116,563. **MY ACADEMY AND DESIGN**. MY ACADEMY, LLC. (U.S. CLS. 100, 101 AND 107). SN 76-704,929. PUB. 1-10-2012. FILED 10-18-2010.
 4,116,569 (*See Class 16 for this trademark*).
 4,116,580. **THE AYERS FOUNDATION LEARN . GROW . SUCCEED AND DESIGN**. THE AYERS FOUNDATION. (U.S. CLS. 100, 101 AND 107). SN 76-708,328. PUB. 1-10-2012. FILED 7-14-2011.
 4,116,583. **TOUGH TIMES FOR LENDERS (STANDARD CHARACTER)**. WINSTEAD PC. (U.S. CLS. 100, 101 AND 107). SN 76-708,424. PUB. 1-10-2012. FILED 7-20-2011.
 4,116,584. **COMPENSATION COMMITTEE CORNER (STANDARD CHARACTER)**. WINSTEAD PC. (U.S. CLS. 100, 101 AND 107). SN 76-708,425. PUB. 1-10-2012. FILED 7-20-2011.
 4,116,591. **EGOTASTIC (STANDARD CHARACTER)**. BUZZ-MEDIA. (U.S. CLS. 100, 101 AND 107). SN 77-187,404. PUB. 1-10-2012. FILED 5-22-2007.
 4,116,592. **NOVELAS EDUCATIVAS AND DESIGN**. NOVELAS EDUCATIVAS, LLC. (U.S. CLS. 100, 101 AND 107). SN 77-241,571. PUB. 1-10-2012. FILED 7-29-2007.
 4,116,593 (*See Class 9 for this trademark*).
 4,116,602 (*See Class 9 for this trademark*).
 4,116,606 (*See Class 9 for this trademark*).
 4,116,608 (*See Class 36 for this trademark*).
 4,116,616 (*See Class 16 for this trademark*).
 4,116,632. **OPERATION: BEFIT MIND . BODY . SOUL AND DESIGN**. ARMY AND AIR FORCE EXCHANGE SERVICE, MULTIPLE CLASS, (INT. CLS. 41 AND 44), (U.S. CLS. 100, 101 AND 107). SN 77-824,460. PUB. 1-10-2012. FILED 9-11-2009.
 4,116,647 (*See Class 35 for this trademark*).
 4,116,656. **ORIGIN AND DESIGN**. ORIGIN ACTIVE LIFESTYLE COMMUNITIES INC., MULTIPLE CLASS, (INT. CLS. 41 AND 43), (U.S. CLS. 100, 101 AND 107). SN 77-920,968. PUB. 1-10-2012. FILED 1-27-2010.
 4,116,663. **LYME LYTE ENTERTAINMENT AND DESIGN**. TRONCOSO, MANUEL, AKA LYME LYTE ENTERTAINMENT, AND TRONCOSO, SANDI, AKA LYME LYTE ENTERTAINMENT, AND SMITH, GREG, AKA LYME LYTE ENTERTAINMENT, (U.S. CLS. 100, 101 AND 107). SN 77-950,135. PUB. 1-10-2012. FILED 3-4-2010.
 4,116,665 (*See Class 36 for this trademark*).
 4,116,678 (*See Class 1 for this trademark*).
 4,116,681 (*See Class 9 for this trademark*).
 4,116,690 (*See Class 35 for this trademark*).
 4,116,697 (*See Class 9 for this trademark*).
 4,116,700 (*See Class 9 for this trademark*).
 4,116,702 (*See Class 16 for this trademark*).
 4,116,705 (*See Class 35 for this trademark*).
 4,116,710 (*See Class 16 for this trademark*).
 4,116,712 (*See Class 10 for this trademark*).
 4,116,718 (*See Class 10 for this trademark*).
 4,116,722. **FUNKYKIDZ AND DESIGN**. FUNUYUIOZ PRODUCTION AB. (U.S. CLS. 100, 101 AND 107). SN 79-091,248. PUB. 1-10-2012. FILED 11-9-2010.
 4,116,726 (*See Class 16 for this trademark*).
 4,116,735 (*See Class 5 for this trademark*).
 4,116,751 (*See Class 9 for this trademark*).
 4,116,763 (*See Class 16 for this trademark*).
 4,116,770 (*See Class 16 for this trademark*).
 4,116,776 (*See Class 35 for this trademark*).
 4,116,795 (*See Class 16 for this trademark*).
 4,116,801 (*See Class 9 for this trademark*).
 4,116,808 (*See Class 16 for this trademark*).
 4,116,831. **TOZZARDO (STANDARD CHARACTER)**. BOEHRINGER INGELHEIM INTERNATIONAL GMBH, MULTIPLE CLASS, (INT. CLS. 41 AND 42), (U.S. CLS. 100, 101 AND 107). SN 79-100,638. PUB. 1-10-2012. FILED 6-1-2011.
 4,116,832. **TOVACTIV (STANDARD CHARACTER)**. BOEHRINGER INGELHEIM INTERNATIONAL GMBH, MULTIPLE CLASS, (INT. CLS. 41 AND 42), (U.S. CLS. 100, 101 AND 107). SN 79-100,639. PUB. 1-10-2012. FILED 6-1-2011.
 4,116,833. **TORRACTO (STANDARD CHARACTER)**. BOEHRINGER INGELHEIM INTERNATIONAL GMBH, MULTIPLE CLASS, (INT. CLS. 41 AND 42), (U.S. CLS. 100, 101 AND 107). SN 79-100,640. PUB. 1-10-2012. FILED 6-1-2011.
 4,116,834. **DYNAGITO (STANDARD CHARACTER)**. BOEHRINGER INGELHEIM INTERNATIONAL GMBH, MULTIPLE CLASS, (INT. CLS. 41 AND 42), (U.S. CLS. 100, 101 AND 107). SN 79-100,643. PUB. 1-10-2012. FILED 6-1-2011.
 4,116,835. **FASILITO (STANDARD CHARACTER)**. BOEHRINGER INGELHEIM INTERNATIONAL GMBH, MULTIPLE CLASS, (INT. CLS. 41 AND 42), (U.S. CLS. 100, 101 AND 107). SN 79-100,644. PUB. 1-10-2012. FILED 6-1-2011.
 4,116,836. **VIVACITO (STANDARD CHARACTER)**. BOEHRINGER INGELHEIM INTERNATIONAL GMBH, MULTIPLE CLASS, (INT. CLS. 41 AND 42), (U.S. CLS. 100, 101 AND 107). SN 79-100,645. PUB. 1-10-2012. FILED 6-1-2011.
 4,116,837. **VIGITO (STANDARD CHARACTER)**. BOEHRINGER INGELHEIM INTERNATIONAL GMBH, MULTIPLE CLASS, (INT. CLS. 41 AND 42), (U.S. CLS. 100, 101 AND 107). SN 79-100,646. PUB. 1-10-2012. FILED 6-1-2011.
 4,116,838. **TRONARTO (STANDARD CHARACTER)**. BOEHRINGER INGELHEIM INTERNATIONAL GMBH, MULTIPLE CLASS, (INT. CLS. 41 AND 42), (U.S. CLS. 100, 101 AND 107). SN 79-100,647. PUB. 1-10-2012. FILED 6-1-2011.
 4,116,839. **GOTHI-C (STANDARD CHARACTER)**. BOEHRINGER INGELHEIM INTERNATIONAL GMBH, MULTIPLE CLASS, (INT. CLS. 41 AND 42), (U.S. CLS. 100, 101 AND 107). SN 79-100,650. PUB. 1-10-2012. FILED 6-7-2011.
 4,116,840. **TELL (STANDARD CHARACTER)**. BOEHRINGER INGELHEIM INTERNATIONAL GMBH, MULTIPLE CLASS, (INT. CLS. 41 AND 42), (U.S. CLS. 100, 101 AND 107). SN 79-100,653. PUB. 1-10-2012. FILED 6-15-2011.
 4,116,844. **TECTONI-C (STANDARD CHARACTER)**. BOEHRINGER INGELHEIM INTERNATIONAL GMBH, MULTIPLE CLASS, (INT. CLS. 41 AND 42), (U.S. CLS. 100, 101 AND 107). SN 79-100,893. PUB. 1-10-2012. FILED 6-15-2011.
 4,116,845 (*See Class 12 for this trademark*).
 4,116,850 (*See Class 9 for this trademark*).
 4,116,876. **YOUFIT (STANDARD CHARACTER)**. YF HOLDINGS, INC., (U.S. CLS. 100, 101 AND 107). SN 85-005,249. PUB. 6-15-2010. FILED 4-2-2010.
 4,116,880 (*See Class 9 for this trademark*).
 4,116,881 (*See Class 9 for this trademark*).
 4,116,882. **BRIDAL IZ MAGAZINE (STANDARD CHARACTER)**. WATTS, CRYSTAL R., (U.S. CLS. 100, 101 AND 107). SN 85-015,590. PUB. 1-10-2012. FILED 4-16-2010.
 4,116,905 (*See Class 14 for this trademark*).
 4,116,914. **ANIMAL FARM FOUNDATION (STANDARD CHARACTER)**. ANIMAL FARM FOUNDATION, INC., MULTIPLE CLASS, (INT. CLS. 41 AND 43), (U.S. CLS. 100, 101 AND 107). SN 85-090,285. PUB. 1-10-2012. FILED 7-22-2010.
 4,116,916 (*See Class 9 for this trademark*).
 4,116,921 (*See Class 9 for this trademark*).
 4,116,934. **UNABASHEDLY FEMALE (STANDARD CHARACTER)**. JULIE M DALEY, DBA CREATIVE WELLSRING, (U.S. CLS. 100, 101 AND 107). SN 85-110,500. PUB. 1-10-2012. FILED 8-18-2010.
 4,116,937 (*See Class 9 for this trademark*).
 4,116,946 (*See Class 35 for this trademark*).
 4,116,949 (*See Class 35 for this trademark*).
 4,116,953. **HIP-NOTIC BELLY DANCE DETROIT AND DESIGN**. CARR, STEPHANIE Y, DBA MIND, BELLY & SOUL, (U.S. CLS. 100, 101 AND 107). SN 85-132,734. PUB. 1-10-2012. FILED 9-18-2010.
 4,116,954 (*See Class 35 for this trademark*).
 4,116,986. **MISCELLANEOUS DESIGN**. QUARTERMAN, SAMANTHA, (U.S. CLS. 100, 101 AND 107). SN 85-177,804. PUB. 1-10-2012. FILED 11-16-2010.
 4,116,987. **WOOLPERT DESIGN GEOSPATIAL INFRASTRUCTURE AND DESIGN**. WOOLPERT, INC., MULTIPLE CLASS, (INT. CLS. 41 AND 42), (U.S. CLS. 100, 101

- AND 107). SN 85-179,700. PUB. 1-10-2012. FILED 11-18-2010.
- 4,116,994. **MATCH&MINGLE (STANDARD CHARACTER)**. STANG, JOSEPH A, DBA MATCH AND MINGLE, MULTIPLE CLASS, (INT. CLS. 41 AND 45), (U.S. CLS. 100, 101 AND 107). SN 85-187,719. PUB. 1-10-2012. FILED 11-30-2010.
- 4,117,006 (*See Class 38 for this trademark*).
- 4,117,007 (*See Class 35 for this trademark*).
- 4,117,008 (*See Class 35 for this trademark*).
- 4,117,009. **STREET MEDICINE (STANDARD CHARACTER)**. THE STREET MEDICINE INSTITUTE, MULTIPLE CLASS, (INT. CLS. 41 AND 44), (U.S. CLS. 100, 101 AND 107). SN 85-193,398. PUB. 1-10-2012. FILED 12-8-2010.
- 4,117,016. **IPREP ACADEMY (STANDARD CHARACTER)**. THE SCHOOL BOARD OF MIAMI-DADE COUNTY, (U.S. CLS. 100, 101 AND 107). SN 85-197,814. PUB. 1-10-2012. FILED 12-14-2010.
- 4,117,022 (*See Class 9 for this trademark*).
- 4,117,023 (*See Class 9 for this trademark*).
- 4,117,024 (*See Class 9 for this trademark*).
- 4,117,042 (*See Class 35 for this trademark*).
- 4,117,046. **G-FORCE (STANDARD CHARACTER)**. MR. GATTI'S, LP, (U.S. CLS. 100, 101 AND 107). SN 85-212,573. PUB. 1-10-2012. FILED 1-7-2011.
- 4,117,057. **NBA HOOP TROOP NBA AND DESIGN**. NBA PROPERTIES, INC., (U.S. CLS. 100, 101 AND 107). SN 85-218,212. PUB. 1-10-2012. FILED 1-14-2011.
- 4,117,059 (*See Class 25 for this trademark*).
- 4,117,063 (*See Class 35 for this trademark*).
- 4,117,078 (*See Class 35 for this trademark*).
- 4,117,079 (*See Class 36 for this trademark*).
- 4,117,080 (*See Class 36 for this trademark*).
- 4,117,090 (*See Class 9 for this trademark*).
- 4,117,092. **APOCALYPSE ONLINE (STANDARD CHARACTER)**. KIM, DAVID, (U.S. CLS. 100, 101 AND 107). SN 85-224,997. PUB. 1-10-2012. FILED 1-24-2011.
- 4,117,093 (*See Class 25 for this trademark*).
- 4,117,098. **TERRA THE NATURE OF OUR WORLD (STANDARD CHARACTER)**. MONTANA STATE UNIVERSITY, (U.S. CLS. 100, 101 AND 107). SN 85-225,806. PUB. 1-10-2012. FILED 1-25-2011.
- 4,117,099 (*See Class 35 for this trademark*).
- 4,117,100. **WESTERN ENERGY (STANDARD CHARACTER)**. WESTERN ENERGY INSTITUTE, (U.S. CLS. 100, 101 AND 107). SN 85-225,860. PUB. 1-10-2012. FILED 1-25-2011.
- 4,117,102 (*See Class 9 for this trademark*).
- 4,117,113. **GOGO BABIES (STANDARD CHARACTER)**. SKOVE, ELLYNNE, MULTIPLE CLASS, (INT. CLS. 41 AND 44), (U.S. CLS. 100, 101 AND 107). SN 85-229,416. PUB. 1-10-2012. FILED 1-29-2011.
- 4,117,116. **6 WAVES AND DESIGN**. SIX WAVES INC., (U.S. CLS. 100, 101 AND 107). SN 85-229,738. PUB. 1-10-2012. FILED 1-31-2011.
- 4,117,121. **STOREYBOOKCLUB.COM (STANDARD CHARACTER)**. JULIET STOREY, (U.S. CLS. 100, 101 AND 107). SN 85-230,406. PUB. 1-10-2012. FILED 1-31-2011.
- 4,117,124 (*See Class 35 for this trademark*).
- 4,117,127 (*See Class 36 for this trademark*).
- 4,117,130. **SHARK BOY (STANDARD CHARACTER)**. DEAN M. ROLL, (U.S. CLS. 100, 101 AND 107). SN 85-231,450. PUB. 1-10-2012. FILED 2-1-2011.
- 4,117,134. **YOU BETTER GET READY ALUMNI FOOTBALL USA AND DESIGN**. CAZET, ROBERT, (U.S. CLS. 100, 101 AND 107). SN 85-232,014. PUB. 1-10-2012. FILED 2-2-2011.
- 4,117,139. **SENSORY EVOLUTION TECHNIQUE (STANDARD CHARACTER)**. FOUR WINDS PERFORMANCE INC., (U.S. CLS. 100, 101 AND 107). SN 85-232,762. PUB. 1-10-2012. FILED 2-2-2011.
- 4,117,141 (*See Class 9 for this trademark*).
- 4,117,143 (*See Class 9 for this trademark*).
- 4,117,146. **HYPE WILLIAMS (STANDARD CHARACTER)**. NAA'ILA ENTERTAINMENT, (U.S. CLS. 100, 101 AND 107). SN 85-233,630. PUB. 1-10-2012. FILED 2-3-2011.
- 4,117,152 (*See Class 35 for this trademark*).
- 4,117,154 (*See Class 35 for this trademark*).
- 4,117,156. **BEAD SOUP BLOG PARTY (STANDARD CHARACTER)**. ANDERSON, LORI, DBA LORI ANDERSON DESIGNS LLC, (U.S. CLS. 100, 101 AND 107). SN 85-234,744. PUB. 1-10-2012. FILED 2-4-2011.
- 4,117,188. **KARATE MASTERS HALL OF FAME (STANDARD CHARACTER)**. LINICK, ANDREW, (U.S. CLS. 100, 101 AND 107). SN 85-239,020. PUB. 1-10-2012. FILED 2-10-2011.
- 4,117,193. **ABOUT ME AND DESIGN**. 9TH STREET PUBLISHING, LLC, (U.S. CLS. 100, 101 AND 107). SN 85-240,135. PUB. 1-10-2012. FILED 2-11-2011.
- 4,117,194. **COPYRIGHT: KNOW IT OR BLOW IT (STANDARD CHARACTER)**. DEBRA WEISS, (U.S. CLS. 100, 101 AND 107). SN 85-240,172. PUB. 1-10-2012. FILED 2-11-2011.
- 4,117,197. **MARTIAL ARTS GRANDMASTERS INTERNATIONAL (STANDARD CHARACTER)**. LINICK, ANDREW, (U.S. CLS. 100, 101 AND 107). SN 85-240,522. PUB. 1-10-2012. FILED 2-11-2011.
- 4,117,203. **I AM NOT SICK I DON'T NEED HELP! (STANDARD CHARACTER)**. DR. XAVIER AMADOR, (U.S. CLS. 100, 101 AND 107). SN 85-241,024. PUB. 1-10-2012. FILED 2-13-2011.
- 4,117,207. **INNOVATRIUM WHERE IDEAS GROW AND DESIGN**. DEGRAFF, JEFFREY T., (U.S. CLS. 100, 101 AND 107). SN 85-241,533. PUB. 1-10-2012. FILED 2-14-2011.
- 4,117,218 (*See Class 19 for this trademark*).
- 4,117,223. **IXL LEARNING (STANDARD CHARACTER)**. IXL LEARNING, INC., (U.S. CLS. 100, 101 AND 107). SN 85-245,164. PUB. 1-10-2012. FILED 2-17-2011.
- 4,117,224. **VIRTUAL EDGE SUMMIT (STANDARD CHARACTER)**. BIZ DEV GROUP, INC., (U.S. CLS. 100, 101 AND 107). SN 85-245,391. PUB. 1-10-2012. FILED 2-17-2011.
- 4,117,229. **BMDMI (STANDARD CHARACTER)**. BAPTIST MEDICAL & DENTAL MISSION INTERNATIONAL, INC., MULTIPLE CLASS, (INT. CLS. 41, 43, 44 AND 45), (U.S. CLS. 100, 101 AND 107). SN 85-245,664. PUB. 1-10-2012. FILED 2-18-2011.
- 4,117,242. **KENTUCKY JOCKEY CLUB (STANDARD CHARACTER)**. CHURCHILL DOWNS INCORPORATED, (U.S. CLS. 100, 101 AND 107). SN 85-247,600. PUB. 1-10-2012. FILED 2-21-2011.
- 4,117,243 (*See Class 16 for this trademark*).
- 4,117,244 (*See Class 16 for this trademark*).
- 4,117,245. **PEDFACTS (STANDARD CHARACTER)**. AMERICAN ACADEMY OF PEDIATRICS, (U.S. CLS. 100, 101 AND 107). SN 85-247,922. PUB. 1-10-2012. FILED 2-22-2011.
- 4,117,246. **VIRTUAL EDGE INSTITUTE (STANDARD CHARACTER)**. BIZ DEV GROUP, INC., (U.S. CLS. 100, 101 AND 107). SN 85-248,208. PUB. 1-10-2012. FILED 2-22-2011.
- 4,117,251. **ECAD EDUCATED CANINES ASSISTING WITH DISABILITIES WWW.ECAD.ORG ECAD AND DESIGN**. DALE PICARD, AND LUCILLE PICARD, (U.S. CLS. 100, 101 AND 107). SN 85-249,293. PUB. 1-10-2012. FILED 2-23-2011.
- 4,117,255. **PROJECT HEAL (STANDARD CHARACTER)**. DALE PICARD, AND LUCILLE PICARD, (U.S. CLS. 100, 101 AND 107). SN 85-250,479. PUB. 1-10-2012. FILED 2-24-2011.
- 4,117,262 (*See Class 9 for this trademark*).
- 4,117,265 (*See Class 35 for this trademark*).
- 4,117,276. **THE FUTURE OF GOLF PLAYS HERE! (STANDARD CHARACTER)**. ROCKY MOUNTAIN JUNIOR GOLF TOUR INC., (U.S. CLS. 100, 101 AND 107). SN 85-255,519. PUB. 1-10-2012. FILED 3-2-2011.
- 4,117,280. **GEOCHEMISTRY, GEOPHYSICS, GEOSYSTEMS (STANDARD CHARACTER)**. AMERICAN GEOPHYSICAL UNION, (U.S. CLS. 100, 101 AND 107). SN 85-256,631. PUB. 1-10-2012. FILED 3-3-2011.
- 4,117,282. **LIFEWAYS (STANDARD CHARACTER)**. LIFEWAYS NORTH AMERICA, INCORPORATED, (U.S. CLS. 100, 101 AND 107). SN 85-256,834. PUB. 1-10-2012. FILED 3-3-2011.
- 4,117,285. **LOVIN' LIFE MINISTRIES (STANDARD CHARACTER)**. HOLY SPIRIT ASSOCIATION FOR THE UNIFICATION OF WORLD CHRISTIANITY, MULTIPLE CLASS, (INT. CLS. 41 AND 45), (U.S. CLS. 100, 101 AND 107). SN 85-258,434. PUB. 1-10-2012. FILED 3-4-2011.
- 4,117,287. **RYAN KIRK PHOTOGRAPHY (STANDARD CHARACTER)**. KIRK, RYAN, (U.S. CLS. 100, 101 AND 107). SN 85-258,651. PUB. 1-10-2012. FILED 3-4-2011.
- 4,117,307. **SASHA SOUZA EVENTS (STYLIZED)**. SASHA V. SOUZA, DBA SASHA SOUZA EVENTS, (U.S. CLS. 100, 101 AND 107). SN 85-261,517. PUB. 1-10-2012. FILED 3-8-2011.

- 4,117,314. **MAHARANI WEDDINGS (STANDARD CHARACTER)**. HOUSING LEADERS LLC, FORMERLY HOUSING LEADERS LLC, (U.S. CLS. 100, 101 AND 107). SN 85-262,700. PUB. 1-10-2012. FILED 3-9-2011.
- 4,117,323. **IXL LEARNING (STYLIZED)**. IXL LEARNING, INC., (U.S. CLS. 100, 101 AND 107). SN 85-266,737. PUB. 1-10-2012. FILED 3-14-2011.
- 4,117,324 (*See Class 38 for this trademark*).
- 4,117,328. **FRONTIER (STANDARD CHARACTER)**. FRONTIER COMMUNICATIONS CORPORATION, MULTIPLE CLASS, (INT. CLS. 41 AND 42), (U.S. CLS. 100, 101 AND 107). SN 85-267,206. PUB. 1-10-2012. FILED 3-15-2011.
- 4,117,333 (*See Class 35 for this trademark*).
- 4,117,335. **HEALING GOURMET (STYLIZED)**. HEALTH-E ENTERPRISES, LLC, (U.S. CLS. 100, 101 AND 107). SN 85-268,456. PUB. 1-10-2012. FILED 3-16-2011.
- 4,117,339. **HALCYON SHORE AND DESIGN**. DAVID TILLMAN, AND LYNN TILLMAN, (U.S. CLS. 100, 101 AND 107). SN 85-269,319. PUB. 1-10-2012. FILED 3-17-2011.
- 4,117,346. **GIRLS ONLY (STANDARD CHARACTER)**. GO PRODUCTIONS, (U.S. CLS. 100, 101 AND 107). SN 85-270,480. PUB. 1-10-2012. FILED 3-18-2011.
- 4,117,347. **GIRLS ONLY THE SECRET COMEDY OF WOMEN BY BARBARA GEHRING AND LINDA KLEIN AND DESIGN**. GO PRODUCTIONS, (U.S. CLS. 100, 101 AND 107). SN 85-270,594. PUB. 1-10-2012. FILED 3-18-2011.
- 4,117,350. **THE GUIDING PRINCIPLES OF PEACE AND UNITY SYSTEM THE GUIDING PRINCIPLES OF PEACE AND UNITY VILLAGE FAMILY GROUP INCENTIVES AND AWARDS AND DESIGN**. SHAAIM FAMILY LLC, (U.S. CLS. 100, 101 AND 107). SN 85-271,661. PUB. 1-10-2012. FILED 3-20-2011.
- 4,117,353. **I AM ENTERTAINMENT AND DESIGN**. I AM ENTERTAINMENT, LLC, (U.S. CLS. 100, 101 AND 107). SN 85-272,453. PUB. 1-10-2012. FILED 3-21-2011.
- 4,117,360. **THE TEXAS CONFLICT COACH AND DESIGN**. CONFLICT CONNECTIONS INC., (U.S. CLS. 100, 101 AND 107). SN 85-273,776. PUB. 1-10-2012. FILED 3-22-2011.
- 4,117,362 (*See Class 25 for this trademark*).
- 4,117,363 (*See Class 9 for this trademark*).
- 4,117,365. **SWEET VICTORY (STANDARD CHARACTER)**. SOLCE, NATASHA, (U.S. CLS. 100, 101 AND 107). SN 85-275,028. PUB. 1-10-2012. FILED 3-23-2011.
- 4,117,380 (*See Class 9 for this trademark*).
- 4,117,384 (*See Class 35 for this trademark*).
- 4,117,405. **PAWS WITH A CAUSE (STANDARD CHARACTER)**. PAWS WITH A CAUSE, MULTIPLE CLASS, (INT. CLS. 41 AND 44), (U.S. CLS. 100, 101 AND 107). SN 85-283,508. PUB. 1-10-2012. FILED 4-1-2011.
- 4,117,421 (*See Class 9 for this trademark*).
- 4,117,428. **CONFLICT CONNECTIONS, INC. AND DESIGN**. CONFLICT CONNECTIONS INC., (U.S. CLS. 100, 101 AND 107). SN 85-289,035. PUB. 1-10-2012. FILED 4-7-2011.
- 4,117,433. **HELLO CRAFT (STANDARD CHARACTER)**. HELLO CRAFT, (U.S. CLS. 100, 101 AND 107). SN 85-290,409. PUB. 1-10-2012. FILED 4-8-2011.
- 4,117,435. **BLOCK PARTY FRIDAYS! (STANDARD CHARACTER)**. THE UPPER SKAGIT INDIAN TRIBE, DBA SKAGIT VALLEY CASINO RESORT, (U.S. CLS. 100, 101 AND 107). SN 85-290,554. PUB. 1-10-2012. FILED 4-8-2011.
- 4,117,438 (*See Class 35 for this trademark*).
- 4,117,439. **NUESTRA ESCUELA (STANDARD CHARACTER)**. NUESTRA ESCUELA, INC., (U.S. CLS. 100, 101 AND 107). SN 85-291,535. PUB. 1-10-2012. FILED 4-11-2011.
- 4,117,445 (*See Class 16 for this trademark*).
- 4,117,448. **J.I.G DINERO (STANDARD CHARACTER)**. TORRES JR. - CATANESE, JOHN ANDREW, (U.S. CLS. 100, 101 AND 107). SN 85-292,856. PUB. 1-10-2012. FILED 4-12-2011.
- 4,117,454. **SEE SHARE SMILE (STANDARD CHARACTER)**. COMPASS BANCSHARES, INC., (U.S. CLS. 100, 101 AND 107). SN 85-293,980. PUB. 1-10-2012. FILED 4-13-2011.
- 4,117,455. **100 YEARS INTERNATIONAL STAR CLASS YACHT RACING ASSOCIATION AND DESIGN**. INTERNATIONAL STAR CLASS YACHT RACING ASSOCIATION, (U.S. CLS. 100, 101 AND 107). SN 85-294,025. PUB. 1-10-2012. FILED 4-13-2011.
- 4,117,456. **SEE SHARE SMILE AND DESIGN**. COMPASS BANCSHARES, INC., (U.S. CLS. 100, 101 AND 107). SN 85-294,213. PUB. 1-10-2012. FILED 4-13-2011.
- 4,117,457. **SEE SHARE SMILE AND DESIGN**. COMPASS BANCSHARES, INC., (U.S. CLS. 100, 101 AND 107). SN 85-294,264. PUB. 1-10-2012. FILED 4-13-2011.
- 4,117,463 (*See Class 38 for this trademark*).
- 4,117,467 (*See Class 9 for this trademark*).
- 4,117,473. **GOORU (STANDARD CHARACTER)**. EDNOVO, (U.S. CLS. 100, 101 AND 107). SN 85-297,122. PUB. 1-10-2012. FILED 4-16-2011.
- 4,117,474. **MISCELLANEOUS DESIGN**. NEW WARRIOR MEDIA, LLC, (U.S. CLS. 100, 101 AND 107). SN 85-297,191. PUB. 1-10-2012. FILED 4-17-2011.
- 4,117,476 (*See Class 35 for this trademark*).
- 4,117,480. **FRANK ROBERSON'S PHYSIQUE TRANSFORMATION CENTER (STANDARD CHARACTER)**. FRANK ROBERSON - PHYSIQUE SPECIALIST CENTER, (U.S. CLS. 100, 101 AND 107). SN 85-298,089. PUB. 1-10-2012. FILED 4-18-2011.
- 4,117,484. **THE CAGE (STANDARD CHARACTER)**. POWDRWOODWARD PA LLC, (U.S. CLS. 100, 101 AND 107). SN 85-298,744. PUB. 1-10-2012. FILED 4-19-2011.
- 4,117,494. **STOREYBOOKCLUB (STANDARD CHARACTER)**. JULIET STOREY, (U.S. CLS. 100, 101 AND 107). SN 85-301,318. PUB. 1-10-2012. FILED 4-21-2011.
- 4,117,496 (*See Class 16 for this trademark*).
- 4,117,499. **THE CHICKEN DONUT (STANDARD CHARACTER)**. THE CHICKEN DONUT, LLC, (U.S. CLS. 100, 101 AND 107). SN 85-302,234. PUB. 1-10-2012. FILED 4-22-2011.
- 4,117,500. **FRESH BOSTON PASTRY (STANDARD CHARACTER)**. THE CHICKEN DONUT, LLC, (U.S. CLS. 100, 101 AND 107). SN 85-302,243. PUB. 1-10-2012. FILED 4-22-2011.
- 4,117,502. **MISCELLANEOUS DESIGN**. THE CHICKEN DONUT, LLC, (U.S. CLS. 100, 101 AND 107). SN 85-302,304. PUB. 1-10-2012. FILED 4-22-2011.
- 4,117,506. **LIPSTICKN'LAUNDRY AND DESIGN**. LIPSTICKN'LAUNDRY LLC, (U.S. CLS. 100, 101 AND 107). SN 85-302,818. PUB. 1-10-2012. FILED 4-23-2011.
- 4,117,507. **FANATCHICKS (STANDARD CHARACTER)**. FANATCHICKS GROUP, LLC, (U.S. CLS. 100, 101 AND 107). SN 85-303,200. PUB. 1-10-2012. FILED 4-25-2011.
- 4,117,509. **BABYGARTEN (STANDARD CHARACTER)**. BABYGARTEN MINNESOTA, LLC, (U.S. CLS. 100, 101 AND 107). SN 85-303,332. PUB. 1-10-2012. FILED 4-25-2011.
- 4,117,510. **FANATCHICKS FOR CHICK WHO DIG SPORTS! AND DESIGN**. FANATCHICKS GROUP, LLC, (U.S. CLS. 100, 101 AND 107). SN 85-303,339. PUB. 1-10-2012. FILED 4-25-2011.
- 4,117,515. **EASY ESPAÑOL LIVE THE LANGUAGE! AND DESIGN**. EASY ESPANOL, INC., (U.S. CLS. 100, 101 AND 107). SN 85-304,252. PUB. 1-10-2012. FILED 4-25-2011.
- 4,117,525. **TPU TAX PREP UNIVERSITY AND DESIGN**. HARBOUR, TREVOR H, (U.S. CLS. 100, 101 AND 107). SN 85-307,252. PUB. 1-10-2012. FILED 4-28-2011.
- 4,117,531. **S SISTEMA TV CANAL UNIVERSITARIO ANA G. MÉNDEZ AND DESIGN**. SISTEMA UNIVERSITARIO ANA G. MENDEZ, INC., AKA SUAGM, (U.S. CLS. 100, 101 AND 107). SN 85-308,646. PUB. 1-10-2012. FILED 4-29-2011.
- 4,117,538. **FITNESS PROPELLED (STANDARD CHARACTER)**. FITNESS PROPELLED LLC, (U.S. CLS. 100, 101 AND 107). SN 85-310,808. PUB. 1-10-2012. FILED 5-3-2011.
- 4,117,558. **STONE SH HART AND DESIGN**. STONE HART BRAND LLC, (U.S. CLS. 100, 101 AND 107). SN 85-315,457. PUB. 10-4-2011. FILED 5-9-2011.
- 4,117,559 (*See Class 35 for this trademark*).
- 4,117,575. **COVERAGE POINTERS (STANDARD CHARACTER)**. HURWITZ & FINE, P.C., (U.S. CLS. 100, 101 AND 107). SN 85-320,250. PUB. 10-4-2011. FILED 5-13-2011.
- 4,117,580. **HOW'S THE MARKET? (STANDARD CHARACTER)**. ALTOS RESEARCH, LLC, (U.S. CLS. 100, 101 AND 107). SN 85-320,916. PUB. 1-10-2012. FILED 5-13-2011.
- 4,117,583. **SURVIVOR SOUTH PACIFIC OUTWIT OUTPLAY OUTLAST AND DESIGN**. SURVIVOR PRODUCTIONS LLC, (U.S. CLS. 100, 101 AND 107). SN 85-322,129. PUB. 1-10-2012. FILED 5-16-2011.
- 4,117,585. **BROWSER (STANDARD CHARACTER)**. LORAIN PUBLIC LIBRARY SYSTEM, (U.S. CLS. 100, 101 AND 107).

- SN 85-322,482. PUB. 1-10-2012. FILED 5-17-2011.
- 4,117,587. **SUPER-U (STANDARD CHARACTER)**. ABRAHAM, THOMAS G., (U.S. CLS. 100, 101 AND 107). SN 85-322,890. PUB. 1-10-2012. FILED 5-17-2011.
- 4,117,590 (*See Class 25 for this trademark*).
- 4,117,593. **MILE HIGH AND DRY (STANDARD CHARACTER)**. AMMASH, SAM, FORMERLY AMMASH, WISSAM, (U.S. CLS. 100, 101 AND 107). SN 85-323,621. PUB. 1-10-2012. FILED 5-18-2011.
- 4,117,605. **WELCOME TO THE D (STANDARD CHARACTER)**. KASSA, MARK, (U.S. CLS. 100, 101 AND 107). SN 85-324,729. PUB. 1-10-2012. FILED 5-19-2011.
- 4,117,616. **SWYMFIT A WATER AND FITNESS GYM AND DESIGN**. VICTORSON, STEVEN EARL, DBA SWYMFIT, (U.S. CLS. 100, 101 AND 107). SN 85-326,406. PUB. 1-10-2012. FILED 5-20-2011.
- 4,117,618. **PIXEL PARTIES (STANDARD CHARACTER)**. PIXEL PARTIES LLC, (U.S. CLS. 100, 101 AND 107). SN 85-326,754. PUB. 1-10-2012. FILED 5-21-2011.
- 4,117,619. **WED GUILD (STANDARD CHARACTER)**. DALEY, ELISABETH SCOTT, AND MERRY, JR., PETER CHARLES, (U.S. CLS. 100, 101 AND 107). SN 85-327,330. PUB. 1-10-2012. FILED 5-23-2011.
- 4,117,621 (*See Class 12 for this trademark*).
- 4,117,625. **AFFINITY GAMING (STANDARD CHARACTER)**. AFFINITY GAMING, LLC, (U.S. CLS. 100, 101 AND 107). SN 85-328,053. PUB. 1-10-2012. FILED 5-23-2011.
- 4,117,637 (*See Class 35 for this trademark*).
- 4,117,645 (*See Class 36 for this trademark*).
- 4,117,652. **CONCERT UNDER THE STARS (STANDARD CHARACTER)**. THE BOK TOWER GARDENS FOUNDATION, INC., DBA BOK TOWER GARDENS, (U.S. CLS. 100, 101 AND 107). SN 85-333,868. PUB. 1-10-2012. FILED 5-31-2011.
- 4,117,658 (*See Class 9 for this trademark*).
- 4,117,660. **LEARNING-FOCUSED (STANDARD CHARACTER)**. LEARNING-FOCUSED SOLUTIONS, INC., (U.S. CLS. 100, 101 AND 107). SN 85-335,386. PUB. 1-10-2012. FILED 6-1-2011.
- 4,117,672 (*See Class 9 for this trademark*).
- 4,117,678. **THEMESTER (STANDARD CHARACTER)**. THE TRUSTEES OF INDIANA UNIVERSITY, (U.S. CLS. 100, 101 AND 107). SN 85-338,721. PUB. 1-10-2012. FILED 6-6-2011.
- 4,117,680. **BIKEOVISION (STANDARD CHARACTER)**. HUNTER, JAN D., (U.S. CLS. 100, 101 AND 107). SN 85-339,815. PUB. 1-10-2012. FILED 6-7-2011.
- 4,117,681. **OUTSTANDING OCCASIONS (STANDARD CHARACTER)**. OUTSTANDING OCCASIONS, L.L.C., (U.S. CLS. 100, 101 AND 107). SN 85-339,885. PUB. 1-10-2012. FILED 6-7-2011.
- 4,117,688. **DR. WRIGHT BREAKS IT DOWN FOR YOU (STANDARD CHARACTER)**. ALL WEATHER SAFETY WHISTLES, (U.S. CLS. 100, 101 AND 107). SN 85-341,890. PUB. 1-10-2012. FILED 6-9-2011.
- 4,117,694. **PURE REBELLION (STANDARD CHARACTER)**. PURE REBELLION MINISTRIES, (U.S. CLS. 100, 101 AND 107). SN 85-342,888. PUB. 1-10-2012. FILED 6-10-2011.
- 4,117,697. **HAPPY CATHOLIC (STANDARD CHARACTER)**. JULIE DAVIS, (U.S. CLS. 100, 101 AND 107). SN 85-343,673. PUB. 1-10-2012. FILED 6-10-2011.
- 4,117,703. **VELOUS (STANDARD CHARACTER)**. TYLER JAMES BRYANT, DBA VELOUS, (U.S. CLS. 100, 101 AND 107). SN 85-344,526. PUB. 1-10-2012. FILED 6-13-2011.
- 4,117,733. **BEYOND THE KIDDIE POOL AND DESIGN**. WILLIAMS, CHRISTOPHER, (U.S. CLS. 100, 101 AND 107). SN 85-349,672. PUB. 1-10-2012. FILED 6-17-2011.
- 4,117,745 (*See Class 35 for this trademark*).
- 4,117,746. **MIAMI BEACH ROWING CLUB AND DESIGN**. MIAMI BEACH WATERSPORTS CENTER INC, (U.S. CLS. 100, 101 AND 107). SN 85-351,438. PUB. 1-10-2012. FILED 6-21-2011.
- 4,117,751. **ROCKETOWN (STANDARD CHARACTER)**. ROCKETOWN OF MIDDLE TENNESSEE, INC., (U.S. CLS. 100, 101 AND 107). SN 85-351,751. PUB. 1-10-2012. FILED 6-21-2011.
- 4,117,759. **DAVE CORWIN'S NOISE & VISION AND DESIGN**. POLCINO, DAVE CORWIN, (U.S. CLS. 100, 101 AND 107). SN 85-352,686. PUB. 1-10-2012. FILED 6-22-2011.
- 4,117,762. **OZZMOSIS (STANDARD CHARACTER)**. SILVER MOUNTAIN PRODUCTIONS LLC, (U.S. CLS. 100, 101 AND 107). SN 85-353,363. PUB. 1-10-2012. FILED 6-22-2011.
- 4,117,766 (*See Class 35 for this trademark*).
- 4,117,772. **MISCELLANEOUS DESIGN**. NAPLES BOTANICAL GARDEN, INC., DBA NAPLES BOTANICAL GARDEN, INC., (U.S. CLS. 100, 101 AND 107). SN 85-354,251. PUB. 1-10-2012. FILED 6-23-2011.
- 4,117,775. **SUNDRESSES AND SEERSUCKERS (STANDARD CHARACTER)**. COMMITMENT TO EXCELLENCE, INC., (U.S. CLS. 100, 101 AND 107). SN 85-354,921. PUB. 1-10-2012. FILED 6-24-2011.
- 4,117,777. **PAPARAZZI PROPOSALS (STANDARD CHARACTER)**. PAP THE QUESTION, LLC, (U.S. CLS. 100, 101 AND 107). SN 85-355,414. PUB. 1-10-2012. FILED 6-24-2011.
- 4,117,783 (*See Class 35 for this trademark*).
- 4,117,793. **ISAAC REMY LAURENT (STANDARD CHARACTER)**. ISAAC REMY LAURENT I.R.L LLC, (U.S. CLS. 100, 101 AND 107). SN 85-357,623. PUB. 1-10-2012. FILED 6-27-2011.
- 4,117,802. **IMAPMYLIFE (STANDARD CHARACTER)**. STRATEGIC SOLUTIONS INTERNATIONAL, INC., MULTIPLE CLASS, (INT. CLS. 41 AND 45), (U.S. CLS. 100, 101 AND 107). SN 85-358,826. PUB. 1-10-2012. FILED 6-28-2011.
- 4,117,810. **WHERE ARE YOU THINKING TONIGHT? (STANDARD CHARACTER)**. NTN BUZZTIME, INC., (U.S. CLS. 100, 101 AND 107). SN 85-359,240. PUB. 1-10-2012. FILED 6-29-2011.
- 4,117,822. **FIRE ENGINEERING UNIVERSITY U AND DESIGN**. PENNWELL CORPORATION, (U.S. CLS. 100, 101 AND 107). SN 85-360,515. PUB. 1-10-2012. FILED 6-30-2011.
- 4,117,829. **LOOK AT THE LYRICS (STANDARD CHARACTER)**. EDWARDS, JUDY A, (U.S. CLS. 100, 101 AND 107). SN 85-361,254. PUB. 1-10-2012. FILED 6-30-2011.
- 4,117,833 (*See Class 35 for this trademark*).
- 4,117,856. **CORE CALLING (STANDARD CHARACTER)**. CORE CALLING, LLC, (U.S. CLS. 100, 101 AND 107). SN 85-364,862. PUB. 1-10-2012. FILED 7-7-2011.
- 4,117,862. **PRESS PRINTS (STANDARD CHARACTER)**. CHRISTOPHER PFEFFERKORN, (U.S. CLS. 100, 101 AND 107). SN 85-365,051. PUB. 1-10-2012. FILED 7-7-2011.
- 4,117,871. **GO ZIP AND DESIGN**. GOZIP LLC, (U.S. CLS. 100, 101 AND 107). SN 85-365,667. PUB. 1-10-2012. FILED 7-7-2011.
- 4,117,883. **BROMS (STANDARD CHARACTER)**. ROBERT BROMFIELD, (U.S. CLS. 100, 101 AND 107). SN 85-366,339. PUB. 1-10-2012. FILED 7-8-2011.
- 4,117,884 (*See Class 35 for this trademark*).
- 4,117,888. **THE PIANO GUYS (STANDARD CHARACTER)**. PT MANAGEMENT, INC., (U.S. CLS. 100, 101 AND 107). SN 85-366,423. PUB. 1-10-2012. FILED 7-8-2011.
- 4,117,890. **HILLBILLY VEGAS (STANDARD CHARACTER)**. HARRIS, STEPHEN, AND REED, JOHN E. III, AND WISE, DONNIE, (U.S. CLS. 100, 101 AND 107). SN 85-366,672. PUB. 1-10-2012. FILED 7-8-2011.
- 4,117,895. **ULTRA BOX (STANDARD CHARACTER)**. IFW LLC, (U.S. CLS. 100, 101 AND 107). SN 85-366,845. PUB. 1-10-2012. FILED 7-8-2011.
- 4,117,897. **THE GARDENS AT HOTEL DEL CORONADO (STYLIZED)**. BSK DEL PARTNERS, LLC, (U.S. CLS. 100, 101 AND 107). SN 85-367,096. PUB. 1-10-2012. FILED 7-8-2011.
- 4,117,901. **DMT DEATHMATCH TOURNAMENT AND DESIGN**. FARRINGTON, KIRK, (U.S. CLS. 100, 101 AND 107). SN 85-367,251. PUB. 1-10-2012. FILED 7-9-2011.
- 4,117,903 (*See Class 35 for this trademark*).
- 4,117,909. **WLC (STANDARD CHARACTER)**. DOSS, GALAL PHILIP HABIB, (U.S. CLS. 100, 101 AND 107). SN 85-367,962. PUB. 1-10-2012. FILED 7-11-2011.
- 4,117,910. **WORLD'S LAST CHANCE (STANDARD CHARACTER)**. DOSS, GALAL PHILIP HABIB, (U.S. CLS. 100, 101 AND 107). SN 85-367,971. PUB. 1-10-2012. FILED 7-11-2011.
- 4,117,925. **MR. HALLOWEENSTER (STANDARD CHARACTER)**. WOODSPHERE PUBLISHING LLC, (U.S. CLS. 100, 101 AND 107). SN 85-368,641. PUB. 1-10-2012. FILED 7-12-2011.
- 4,117,930. **THE MOONLIGHT BAKER (STANDARD CHAR-**

- ACTER). KARTER, KIMBERLY B., (U.S. CLS. 100, 101 AND 107). SN 85-368,970. PUB. 1-10-2012. FILED 7-12-2011.
- 4,117,937. **RARE ROOTS PUBLISHING (STANDARD CHARACTER)**. PEARLMAN, GREGORY D., (U.S. CLS. 100, 101 AND 107). SN 85-369,148. PUB. 1-10-2012. FILED 7-12-2011.
- 4,117,948. **CMGC INSTITUTE AND DESIGN**. CMGC CONSULTING, L.C., (U.S. CLS. 100, 101 AND 107). SN 85-369,532. PUB. 1-10-2012. FILED 7-12-2011.
- 4,117,957. **RUNNING 101 (STANDARD CHARACTER)**. POTOMAC RIVER RUNNING, INC., AKA =PR= RUNNING, (U.S. CLS. 100, 101 AND 107). SN 85-370,247. PUB. 1-10-2012. FILED 7-13-2011.
- 4,117,960. **GINGOLD THEATRICAL GROUP (STANDARD CHARACTER)**. GINGOLD THEATRICAL GROUP, INC, (U.S. CLS. 100, 101 AND 107). SN 85-370,386. PUB. 1-10-2012. FILED 7-13-2011.
- 4,117,966. **MC AND DESIGN**. MAYRON COLE PIANO CONSERVATORY, INC., (U.S. CLS. 100, 101 AND 107). SN 85-370,587. PUB. 1-10-2012. FILED 7-13-2011.
- 4,117,967. **STEM CONNECTOR SCIENCE, TECHNOLOGY, ENGINEERING & MATHEMATICS EDUCATION (STYLIZED)**. DIVERSIFIED SEARCH, (U.S. CLS. 100, 101 AND 107). SN 85-370,628. PUB. 1-10-2012. FILED 7-13-2011.
- 4,117,973. **CUPID FOR HIRE (STANDARD CHARACTER)**. MARLA MARTENSON, MULTIPLE CLASS, (INT. CLS. 41 AND 45), (U.S. CLS. 100, 101 AND 107). SN 85-370,859. PUB. 1-10-2012. FILED 7-13-2011.
- 4,117,975. **MISCELLANEOUS DESIGN**. MARLA MARTENSON, MULTIPLE CLASS, (INT. CLS. 41 AND 45), (U.S. CLS. 100, 101 AND 107). SN 85-370,865. PUB. 1-10-2012. FILED 7-13-2011.
- 4,117,978. **COLLEGESCENE (STANDARD CHARACTER)**. COLLEGESCENE LLC, (U.S. CLS. 100, 101 AND 107). SN 85-370,978. PUB. 1-10-2012. FILED 7-14-2011.
- 4,117,984 (*See Class 35 for this trademark*).
- 4,117,992. **EDUCATION THROUGH INNOVATION (STANDARD CHARACTER)**. BIOMET 3I, LLC, (U.S. CLS. 100, 101 AND 107). SN 85-371,441. PUB. 1-10-2012. FILED 7-14-2011.
- 4,117,993. **THE INSTITUTE FOR IMPLANT & RECONSTRUCTIVE DENTISTRY AND DESIGN**. BIOMET 3I, LLC, (U.S. CLS. 100, 101 AND 107). SN 85-371,446. PUB. 1-10-2012. FILED 7-14-2011.
- 4,117,994. **IIRD (STANDARD CHARACTER)**. BIOMET 3I, LLC, (U.S. CLS. 100, 101 AND 107). SN 85-371,450. PUB. 1-10-2012. FILED 7-14-2011.
- 4,117,996. **PHILAU (STANDARD CHARACTER)**. PHILADELPHIA UNIVERSITY, (U.S. CLS. 100, 101 AND 107). SN 85-371,585. PUB. 1-10-2012. FILED 7-14-2011.
- 4,118,000. **THE LEAVE AND DESIGN**. SWEETLAND, DAVID E., (U.S. CLS. 100, 101 AND 107). SN 85-371,771. PUB. 1-10-2012. FILED 7-14-2011.
- 4,118,008. **OOHRAH BOUDOIR (STANDARD CHARACTER)**. KUNICKI PHOTOGRAPHY, INC., (U.S. CLS. 100, 101 AND 107). SN 85-372,041. PUB. 1-10-2012. FILED 7-15-2011.
- 4,118,031. **I'M IN HATE WITH LOVE (STANDARD CHARACTER)**. HUMAN LOVES HUMAN, INC., (U.S. CLS. 100, 101 AND 107). SN 85-372,796. PUB. 12-13-2011. FILED 7-15-2011.
- 4,118,039. **IRON GM (STANDARD CHARACTER)**. IRON GM, LLC, (U.S. CLS. 100, 101 AND 107). SN 85-373,042. PUB. 1-10-2012. FILED 7-16-2011.
- 4,118,041. **BOOKSLUT (STANDARD CHARACTER)**. CRISPIN, JESSICA D., DBA CRISPIN, JESSA, (U.S. CLS. 100, 101 AND 107). SN 85-373,062. PUB. 1-10-2012. FILED 7-16-2011.
- 4,118,043. **KITCHEN WIZARDS (STANDARD CHARACTER)**. KATHY'S JUST DESSERTS, INC., (U.S. CLS. 100, 101 AND 107). SN 85-373,094. PUB. 1-10-2012. FILED 7-16-2011.
- 4,118,044. **KITCHEN WIZARDS DISCOVER THE MAGIC OF COOKING, ONE BITE AT A TIME! AND DESIGN**. KATHY'S JUST DESSERTS, INC., (U.S. CLS. 100, 101 AND 107). SN 85-373,095. PUB. 1-10-2012. FILED 7-16-2011.
- 4,118,050. **THOUGHT HAVEN (STANDARD CHARACTER)**. RIDENOUR, BRENDAN ROSS, DBA THOUGHT HAVEN, (U.S. CLS. 100, 101 AND 107). SN 85-373,349. PUB. 1-10-2012. FILED 7-17-2011.
- 4,118,051 (*See Class 24 for this trademark*).
- 4,118,053. **BFC (STANDARD CHARACTER)**. BOSTON FENCING CLUB, INC., (U.S. CLS. 100, 101 AND 107). SN 85-373,479. PUB. 1-10-2012. FILED 7-18-2011.
- 4,118,057. **100 WEEK SPRINT (STANDARD CHARACTER)**. CAREER INVESTMENT ADVISORS, INC., (U.S. CLS. 100, 101 AND 107). SN 85-373,559. PUB. 1-10-2012. FILED 7-18-2011.
- 4,118,062. **SUPERIOR HIKING TRAIL AND DESIGN**. SUPERIOR HIKING TRAIL ASSOCIATION, (U.S. CLS. 100, 101 AND 107). SN 85-373,617. PUB. 1-10-2012. FILED 7-18-2011.
- 4,118,066. **PEAK NEUROFITNESS AND DESIGN**. MARC G. TIMM, (U.S. CLS. 100, 101 AND 107). SN 85-373,668. PUB. 1-10-2012. FILED 7-18-2011.
- 4,118,068. **L'ECOLE DE LA MAISON AT THE OSTHOFF RESORT (STANDARD CHARACTER)**. OSTHOFF MANAGEMENT CORP., (U.S. CLS. 100, 101 AND 107). SN 85-373,679. PUB. 1-10-2012. FILED 7-18-2011.
- 4,118,075. **THE RED ROSE GENTLEMEN'S CLUB AND DESIGN**. JARAGON MANAGEMENT, LLC, (U.S. CLS. 100, 101 AND 107). SN 85-373,838. PUB. 1-10-2012. FILED 7-18-2011.
- 4,118,077. **CLOUDY COMMUNICATION (STANDARD CHARACTER)**. MCCLORY, MICHAEL R., (U.S. CLS. 100, 101 AND 107). SN 85-373,876. PUB. 1-10-2012. FILED 7-18-2011.
- 4,118,088. **SINGERS COMPANY AND DESIGN**. SINGERS COMPANY, LLC, (U.S. CLS. 100, 101 AND 107). SN 85-374,210. PUB. 1-10-2012. FILED 7-18-2011.
- 4,118,092. **PACIFIC COAST OPERA AND DESIGN**. PACIFIC COAST OPERA, A CALIFORNIA NON-PROFIT PUBLIC BENEFIT CORPORATION, (U.S. CLS. 100, 101 AND 107). SN 85-374,247. PUB. 1-10-2012. FILED 7-18-2011.
- 4,118,093. **CPS PHOTOGRAPHY (STANDARD CHARACTER)**. CPS PHOTOGRAPHY, LLC, (U.S. CLS. 100, 101 AND 107). SN 85-374,262. PUB. 1-10-2012. FILED 7-18-2011.
- 4,118,107. **ERIN SCOTT (STANDARD CHARACTER)**. ERIN SCOTT PHOTOGRAPHY LLC, (U.S. CLS. 100, 101 AND 107). SN 85-374,496. PUB. 1-10-2012. FILED 7-19-2011.
- 4,118,122. **BURLESQUE STRIP STRIP HOORAY! (STANDARD CHARACTER)**. STRIP STRIP HOORAY!, INC., (U.S. CLS. 100, 101 AND 107). SN 85-374,857. PUB. 1-10-2012. FILED 7-19-2011.
- 4,118,128 (*See Class 35 for this trademark*).
- 4,118,131. **GP FORUM AND DESIGN**. COMPLIANCE IMPLEMENTATION SERVICES, AKA CIS, MULTIPLE CLASS, (INT. CLS. 41 AND 45), (U.S. CLS. 100, 101 AND 107). SN 85-375,060. PUB. 1-10-2012. FILED 7-19-2011.
- 4,118,132 (*See Class 9 for this trademark*).
- 4,118,143. **INTERNATIONAL CENTER FOR FOODSERVICE EDUCATION AND DESIGN**. NEW YORK STATE RESTAURANT ASSOCIATION EDUCATIONAL FOUNDATION, (U.S. CLS. 100, 101 AND 107). SN 85-375,299. PUB. 1-10-2012. FILED 7-19-2011.
- 4,118,147. **HOPE AT HOME (STANDARD CHARACTER)**. HOPE WINE LLC, DBA ONE HOPE WINE, (U.S. CLS. 100, 101 AND 107). SN 85-375,323. PUB. 1-10-2012. FILED 7-19-2011.
- 4,118,157. **TSC TRINITY SOUND COMPANY AND DESIGN**. TSC / TRINITY SOUND COMPANY, (U.S. CLS. 100, 101 AND 107). SN 85-375,435. PUB. 1-10-2012. FILED 7-19-2011.
- 4,118,161 (*See Class 25 for this trademark*).
- 4,118,165. **CA CLUTCH ATHLETE AND DESIGN**. STONKUS, MARK A., MULTIPLE CLASS, (INT. CLS. 41 AND 44), (U.S. CLS. 100, 101 AND 107). SN 85-375,526. PUB. 1-10-2012. FILED 7-19-2011.
- 4,118,167. **FMTOWN (STANDARD CHARACTER)**. EMPERORS GROUP, LLC, (U.S. CLS. 100, 101 AND 107). SN 85-375,575. PUB. 1-10-2012. FILED 7-19-2011.
- 4,118,182. **FS M AND DESIGN**. FREQUENCY SPECIFIC SEMINARS, INC., (U.S. CLS. 100, 101 AND 107). SN 85-375,942. PUB. 1-10-2012. FILED 7-20-2011.
- 4,118,187. **S AND DESIGN**. CHRISTIAN COPYRIGHT LICENSING INTERNATIONAL, INC., (U.S. CLS. 100, 101 AND 107). SN 85-376,252. PUB. 1-10-2012. FILED 7-20-2011.
- 4,118,200. **IT INSIDER ONLINE (STANDARD CHARACTER)**. STUDIO ONE NETWORKS, INC., (U.S. CLS. 100, 101 AND 107). SN 85-376,799. PUB. 1-10-2012. FILED 7-20-2011.
- 4,118,226 (*See Class 25 for this trademark*).
- 4,118,228. **FITRESPONDER (STYLIZED)**. FASS CONSULTING, (U.S. CLS. 100, 101 AND 107). SN 85-377,734. PUB. 1-10-2012. FILED 7-21-2011.

- 4,118,255. **NEW LIFE SYMPHONY ORCHESTRA (STANDARD CHARACTER)**. NEW LIFE SYMPHONY ORCHESTRA, (U.S. CLS. 100, 101 AND 107). SN 85-378,974. PUB. 1-10-2012. FILED 7-22-2011.
- 4,118,260. **PATIENT EXPERIENCE OWNERSHIP (STANDARD CHARACTER)**. CUSTOMER FOCUS, INC., (U.S. CLS. 100, 101 AND 107). SN 85-379,327. PUB. 1-10-2012. FILED 7-24-2011.
- 4,118,263. **DOG GENIE (STANDARD CHARACTER)**. TUTTLE, GENE, (U.S. CLS. 100, 101 AND 107). SN 85-379,598. PUB. 1-10-2012. FILED 7-25-2011.
- 4,118,265. **CELEBRITIES OF MAGIC (STANDARD CHARACTER)**. SAYLOR, RONALD, (U.S. CLS. 100, 101 AND 107). SN 85-379,714. PUB. 1-10-2012. FILED 7-25-2011.
- 4,118,266. **DK RACING (STANDARD CHARACTER)**. DYLAN KWASNIEWSKI IP HOLDING CO., LLC, (U.S. CLS. 100, 101 AND 107). SN 85-379,772. PUB. 1-10-2012. FILED 7-25-2011.
- 4,118,278. **SLIGHTLY STOOPID (STANDARD CHARACTER)**. STOOPID TOURING, (U.S. CLS. 100, 101 AND 107). SN 85-380,268. PUB. 1-10-2012. FILED 7-25-2011.
- 4,118,283. **SEND YOUR DOG TO BOOT CAMP K-9 COMPANIONS AND DESIGN**. KINGSDEN'S K-9 COMPANIONS-K-9 SECURITY AND DETECTION INT'L. LLC, (U.S. CLS. 100, 101 AND 107). SN 85-380,403. PUB. 1-10-2012. FILED 7-25-2011.
- 4,118,284. **PLATINUM SUPPLIER PROGRAM (STANDARD CHARACTER)**. WILLIAMSON, PAMELA, (U.S. CLS. 100, 101 AND 107). SN 85-380,420. PUB. 1-10-2012. FILED 7-25-2011.
- 4,118,313. **EMPOWER (STANDARD CHARACTER)**. FITNESS EQUIPMENT MANUFACTURING, LLC, (U.S. CLS. 100, 101 AND 107). SN 85-386,828. PUB. 1-10-2012. FILED 8-2-2011.
- 4,118,316 (*See Class 25 for this trademark*).
- 4,118,320. **GADGET GRRL (STANDARD CHARACTER)**. LEFT COAST MEDIA, INC., (U.S. CLS. 100, 101 AND 107). SN 85-387,654. PUB. 1-10-2012. FILED 8-2-2011.
- 4,118,321. **TRAINWRECK (STANDARD CHARACTER)**. MICHAEL BAKER, (U.S. CLS. 100, 101 AND 107). SN 85-387,750. PUB. 1-10-2012. FILED 8-2-2011.
- 4,118,331. **UNIRI (STANDARD CHARACTER)**. PRICE, SCOTT, DBA UNIRI, (U.S. CLS. 100, 101 AND 107). SN 85-388,156. PUB. 1-10-2012. FILED 8-3-2011.
- 4,118,334. **EXCEPTIONAL CANINE AND DESIGN**. STUDIO ONE NETWORKS, INC., (U.S. CLS. 100, 101 AND 107). SN 85-388,444. PUB. 1-10-2012. FILED 8-3-2011.
- 4,118,349. **THE WATERFORD SCHOOL (STANDARD CHARACTER)**. WATERFORD SCHOOL, LLC, (U.S. CLS. 100, 101 AND 107). SN 85-389,536. PUB. 1-10-2012. FILED 8-4-2011.
- 4,118,350. **THE WATERFORD SCHOOL W HONOR BEAUTY WISDOM AND DESIGN**. WATERFORD SCHOOL, LLC, (U.S. CLS. 100, 101 AND 107). SN 85-389,542. PUB. 1-10-2012. FILED 8-4-2011.
- 4,118,351. **W THE WATERFORD SCHOOL AND DESIGN**. WATERFORD SCHOOL, LLC, (U.S. CLS. 100, 101 AND 107). SN 85-389,551. PUB. 1-10-2012. FILED 8-4-2011.
- 4,118,385. **QUANTUM CLAIRVOYANCE (STANDARD CHARACTER)**. THE TEMPLE OF SELF-ASCENSION, (U.S. CLS. 100, 101 AND 107). SN 85-391,923. PUB. 1-10-2012. FILED 8-8-2011.
- 4,118,392. **IN FOCUS (STANDARD CHARACTER)**. THE ATLANTIC MONTHLY GROUP, INC., MULTIPLE CLASS, (INT. CLS. 41 AND 42), (U.S. CLS. 100, 101 AND 107). SN 85-392,017. PUB. 1-10-2012. FILED 8-8-2011.
- 4,118,393. **DEVELOPMENTS (STANDARD CHARACTER)**. DIGITAL AGE LEARNING, DBA DEVELOPMENTS, (U.S. CLS. 100, 101 AND 107). SN 85-392,053. PUB. 1-10-2012. FILED 8-8-2011.
- 4,118,394. **DEVELOPMENTS AND DESIGN**. DIGITAL AGE LEARNING, DBA DEVELOPMENTS, (U.S. CLS. 100, 101 AND 107). SN 85-392,091. PUB. 1-10-2012. FILED 8-8-2011.
- 4,118,395. **WE LOCALS AND DESIGN**. NP IP HOLDINGS LLC, (U.S. CLS. 100, 101 AND 107). SN 85-392,116. PUB. 1-10-2012. FILED 8-8-2011.
- 4,118,396. **GUERRILLA EVENTS (STANDARD CHARACTER)**. DIGITAL AGE LEARNING, DBA DEVELOPMENTS, (U.S. CLS. 100, 101 AND 107). SN 85-392,136. PUB. 1-10-2012. FILED 8-8-2011.
- 4,118,398. **DEVELOPING PEOPLE WHO DEVELOP SOFTWARE (STANDARD CHARACTER)**. DIGITAL AGE LEARNING, DBA DEVELOPMENTS, (U.S. CLS. 100, 101 AND 107). SN 85-392,186. PUB. 1-10-2012. FILED 8-8-2011.
- 4,118,399 (*See Class 30 for this trademark*).
- 4,118,403. **STYLECOMPASS (STANDARD CHARACTER)**. ISTDIBS.COM, INC., (U.S. CLS. 100, 101 AND 107). SN 85-392,247. PUB. 1-10-2012. FILED 8-8-2011.
- 4,118,404. **UNCLE ALICE (STANDARD CHARACTER)**. SUTTON, GEORGE R., (U.S. CLS. 100, 101 AND 107). SN 85-392,266. PUB. 1-10-2012. FILED 8-8-2011.
- 4,118,429. **GLP (STANDARD CHARACTER)**. NBTA FOUNDATION, (U.S. CLS. 100, 101 AND 107). SN 85-392,903. PUB. 1-10-2012. FILED 8-9-2011.
- 4,118,434. **GET SHOT NAKED AND DESIGN**. KITA, NATALIE, DBA GET SHOT NAKED, (U.S. CLS. 100, 101 AND 107). SN 85-393,030. PUB. 1-10-2012. FILED 8-9-2011.
- 4,118,436 (*See Class 16 for this trademark*).
- 4,118,441. **FOTOLANTHROPY AND DESIGN**. KATIE NORRIS COLLECTION, LLC, AKA FOTOLANTHROPY, (U.S. CLS. 100, 101 AND 107). SN 85-393,101. PUB. 1-10-2012. FILED 8-9-2011.
- 4,118,442. **BABYBALL (STANDARD CHARACTER)**. YOUNG SPORTS LTD, DBA YOUNG SPORTS, (U.S. CLS. 100, 101 AND 107). SN 85-393,105. PUB. 1-10-2012. FILED 8-9-2011.
- 4,118,447. **BURN SWITCH (STANDARD CHARACTER)**. BURN SWITCH, (U.S. CLS. 100, 101 AND 107). SN 85-393,200. PUB. 1-10-2012. FILED 8-9-2011.
- 4,118,448. **GOLFSWINGFREAK (STANDARD CHARACTER)**. BRIAN LOVEGREN, (U.S. CLS. 100, 101 AND 107). SN 85-393,228. PUB. 1-10-2012. FILED 8-9-2011.
- 4,118,455. **PALCS (STANDARD CHARACTER)**. PENNSYLVANIA LEADERSHIP CHARTER SCHOOL, INC., (U.S. CLS. 100, 101 AND 107). SN 85-393,305. PUB. 1-10-2012. FILED 8-9-2011.
- 4,118,461. **BIG BREAK (STANDARD CHARACTER)**. AMERICAN EXPRESS MARKETING & DEVELOPMENT CORP., (U.S. CLS. 100, 101 AND 107). SN 85-393,374. PUB. 1-10-2012. FILED 8-9-2011.
- 4,118,463. **BIG BREAK FOR SMALL BUSINESS (STANDARD CHARACTER)**. AMERICAN EXPRESS MARKETING & DEVELOPMENT CORP., (U.S. CLS. 100, 101 AND 107). SN 85-393,385. PUB. 1-10-2012. FILED 8-9-2011.
- 4,118,473. **CASINO REAL AND DESIGN**. AIRPORT SHOPPES AND HOTELS CORPORATION, (U.S. CLS. 100, 101 AND 107). SN 85-393,551. PUB. 1-10-2012. FILED 8-9-2011.
- 4,118,477. **ENGINE 2 (STANDARD CHARACTER)**. ENGINE 2 FOR LIFE LLC, MULTIPLE CLASS, (INT. CLS. 41 AND 44), (U.S. CLS. 100, 101 AND 107). SN 85-393,656. PUB. 1-10-2012. FILED 8-9-2011.
- 4,118,478. **PEACEFIRE AND DESIGN**. THE RECONCILIATION CENTRE, NFP, (U.S. CLS. 100, 101 AND 107). SN 85-393,734. PUB. 1-10-2012. FILED 8-9-2011.
- 4,118,479 (*See Class 25 for this trademark*).
- 4,118,481. **THERE IS NO PEACE ONLY CONFLICT (STANDARD CHARACTER)**. CLUB CONFLICT, INC., (U.S. CLS. 100, 101 AND 107). SN 85-393,774. PUB. 1-10-2012. FILED 8-9-2011.
- 4,118,491. **SWICKPIX (STANDARD CHARACTER)**. SWICKPIX, LLC, (U.S. CLS. 100, 101 AND 107). SN 85-393,977. PUB. 1-10-2012. FILED 8-10-2011.
- 4,118,497 (*See Class 25 for this trademark*).
- 4,118,500. **EVENTISTA (STANDARD CHARACTER)**. BERMAN, ERICA LAYNE, (U.S. CLS. 100, 101 AND 107). SN 85-394,169. PUB. 1-10-2012. FILED 8-10-2011.
- 4,118,501. **FOXY SHAZAM (STANDARD CHARACTER)**. FOXY SHAZAM, LLC, (U.S. CLS. 100, 101 AND 107). SN 85-394,223. PUB. 1-10-2012. FILED 8-10-2011.
- 4,118,502. **STEP IN STEP OUT (STANDARD CHARACTER)**. LET IT MOVE, INC., (U.S. CLS. 100, 101 AND 107). SN 85-394,231. PUB. 1-10-2012. FILED 8-10-2011.
- 4,118,504. **EMERGING LEGACIES (STANDARD CHARACTER)**. EMERGING LEGACIES LLC, (U.S. CLS. 100, 101 AND 107). SN 85-394,275. PUB. 1-10-2012. FILED 8-10-2011.
- 4,118,530. **ISYSED (STANDARD CHARACTER)**. ISYS SOLUTIONS, INC., (U.S. CLS. 100, 101 AND 107). SN 85-394,872.

- PUB. 1-10-2012. FILED 8-10-2011.
- 4,118,532. **ISYSED AND DESIGN**. ISYS SOLUTIONS, INC., (U.S. CLS. 100, 101 AND 107). SN 85-394,897. PUB. 1-10-2012. FILED 8-10-2011.
- 4,118,533. **CAREERSMART (STANDARD CHARACTER)**. ISYS SOLUTIONS, INC., (U.S. CLS. 100, 101 AND 107). SN 85-394,936. PUB. 1-10-2012. FILED 8-10-2011.
- 4,118,535. **CJDIVAS AND DESIGN**. HEARTSHINES, INC., DBA CHUNJIDO ASSOCIATION, (U.S. CLS. 100, 101 AND 107). SN 85-394,978. PUB. 1-10-2012. FILED 8-10-2011.
- 4,118,536. **TIMESHEPHERD (STANDARD CHARACTER)**. DIANE CATHERINE BERRY, (U.S. CLS. 100, 101 AND 107). SN 85-394,988. PUB. 1-10-2012. FILED 8-10-2011.
- 4,118,539. **LOVEFEAST (STANDARD CHARACTER)**. LOVEFEAST LIFE, LLC, (U.S. CLS. 100, 101 AND 107). SN 85-395,014. PUB. 1-10-2012. FILED 8-11-2011.
- 4,118,540. **BLOGLOVE (STANDARD CHARACTER)**. LOVEFEAST LIFE, LLC, (U.S. CLS. 100, 101 AND 107). SN 85-395,017. PUB. 1-10-2012. FILED 8-11-2011.
- 4,118,548. **RESPECT THE WEST (STANDARD CHARACTER)**. CHUNG & ASSOCIATES, LLC, DBA CASHMERE AGENCY, (U.S. CLS. 100, 101 AND 107). SN 85-395,220. PUB. 1-10-2012. FILED 8-11-2011.
- 4,118,556. **SFAI (STANDARD CHARACTER)**. SAN FRANCISCO ART INSTITUTE, (U.S. CLS. 100, 101 AND 107). SN 85-395,357. PUB. 1-10-2012. FILED 8-11-2011.
- 4,118,569. **FOOLMOON (STANDARD CHARACTER)**. MARK TUCKER, (U.S. CLS. 100, 101 AND 107). SN 85-395,687. PUB. 1-10-2012. FILED 8-11-2011.
- 4,118,570 (*See Class 38 for this trademark*).
- 4,118,573. **X-MEN (STANDARD CHARACTER)**. MARVEL CHARACTERS, INC., (U.S. CLS. 100, 101 AND 107). SN 85-395,742. PUB. 1-10-2012. FILED 8-11-2011.
- 4,118,576. **EXAMPLESHIP (STANDARD CHARACTER)**. BERNSTEIN, ANDREW, (U.S. CLS. 100, 101 AND 107). SN 85-395,759. PUB. 1-10-2012. FILED 8-11-2011.
- 4,118,578. **OPEN SPACE FOR YOUR MIND (STANDARD CHARACTER)**. KANEKO, (U.S. CLS. 100, 101 AND 107). SN 85-395,785. PUB. 1-10-2012. FILED 8-11-2011.
- 4,118,587. **THE MOTHER OF 'ME' TIME (STANDARD CHARACTER)**. REBECCA SCRITCHFIELD MEDIA, LLC, (U.S. CLS. 100, 101 AND 107). SN 85-395,898. PUB. 1-10-2012. FILED 8-11-2011.
- 4,118,590. **LILY AND THE TIGERS (STANDARD CHARACTER)**. HOOD, CASEY, (U.S. CLS. 100, 101 AND 107). SN 85-395,933. PUB. 1-10-2012. FILED 8-11-2011.
- 4,118,602. **MISCELLANEOUS DESIGN**. ATLANTA ICEPLEX CORP., (U.S. CLS. 100, 101 AND 107). SN 85-396,221. PUB. 1-10-2012. FILED 8-12-2011.
- 4,118,608. **MISCELLANEOUS DESIGN**. KANEKO, (U.S. CLS. 100, 101 AND 107). SN 85-396,368. PUB. 1-10-2012. FILED 8-12-2011.
- 4,118,610. **MMTIC (STANDARD CHARACTER)**. MURPHY, ELIZABETH, AND MEISGEIER, CHARLES, (U.S. CLS. 100, 101 AND 107). SN 85-396,548. PUB. 1-10-2012. FILED 8-12-2011.
- 4,118,611. **HELLO (STANDARD CHARACTER)**. HEELLO, INC., (U.S. CLS. 100, 101 AND 107). SN 85-396,553. PUB. 1-10-2012. FILED 8-12-2011.
- 4,118,612. **JHFN (STANDARD CHARACTER)**. JOHN HANCOCK LIFE INSURANCE COMPANY (U.S.A.), (U.S. CLS. 100, 101 AND 107). SN 85-396,571. PUB. 1-10-2012. FILED 8-12-2011.
- 4,118,628. **DISTINKION (STANDARD CHARACTER)**. DISTINKION INCORPORATED, (U.S. CLS. 100, 101 AND 107). SN 85-396,874. PUB. 1-10-2012. FILED 8-12-2011.
- 4,118,630. **WRITERACCESS (STANDARD CHARACTER)**. WRITER ACCESS, INC., (U.S. CLS. 100, 101 AND 107). SN 85-396,909. PUB. 1-10-2012. FILED 8-12-2011.
- 4,118,670 (*See Class 35 for this trademark*).
- 4,118,671 (*See Class 35 for this trademark*).
- 4,118,672 (*See Class 35 for this trademark*).
- 4,118,692. **SRCH (STANDARD CHARACTER)**. STARBUCKS CORPORATION, DBA STARBUCKS COFFEE COMPANY, (U.S. CLS. 100, 101 AND 107). SN 85-416,552. PUB. 1-10-2012. FILED 9-7-2011.
- 4,118,699. **PAY ATTENTION (STANDARD CHARACTER)**. YODER, JJ, DBA PAY ATTENTION ENTERTAINMENT, (U.S. CLS. 100, 101 AND 107). SN 85-422,701. PUB. 1-10-2012. FILED 9-14-2011.
- 4,118,705. **"I RIDE PARK CITY" (STANDARD CHARACTER)**. GREATER PARK CITY COMPANY, (U.S. CLS. 100, 101 AND 107). SN 85-426,982. PUB. 1-10-2012. FILED 9-20-2011.
- 4,118,709. **MASTER THE ROLE (STANDARD CHARACTER)**. SAGEPRESENCE, LLC, (U.S. CLS. 100, 101 AND 107). SN 85-429,049. PUB. 1-10-2012. FILED 9-22-2011.
- 4,118,717. **ARACONTENT (STANDARD CHARACTER)**. ARANET, INC., (U.S. CLS. 100, 101 AND 107). SN 85-435,382. PUB. 1-10-2012. FILED 9-29-2011.
- 4,118,721. **RESPUESTA OPORTUNA (STANDARD CHARACTER)**. TELEVISA, S.A. DE C.V., (U.S. CLS. 100, 101 AND 107). SN 85-440,960. PUB. 1-10-2012. FILED 10-6-2011.
- 4,118,725 (*See Class 9 for this trademark*).
- 4,118,729. **EL MAÑANERO (STANDARD CHARACTER)**. TELEVISA, S.A. DE C.V., (U.S. CLS. 100, 101 AND 107). SN 85-448,033. PUB. 1-10-2012. FILED 10-14-2011.
- 4,118,732. **SHAKESBLOGGING (STANDARD CHARACTER)**. ANDERSON HOOPER, TANYA, (U.S. CLS. 100, 101 AND 107). SN 85-455,944. PUB. 1-10-2012. FILED 10-25-2011.

CLASS 42—SCIENTIFIC AND COMPUTER SERVICES

- 4,116,571 (*See Class 35 for this trademark*).
- 4,116,572 (*See Class 35 for this trademark*).
- 4,116,573 (*See Class 9 for this trademark*).
- 4,116,574 (*See Class 9 for this trademark*).
- 4,116,594 (*See Class 19 for this trademark*).
- 4,116,598. **PASTEROCK (STANDARD CHARACTER)**. GOLD-ER PASTE TECHNOLOGY LTD., (U.S. CLS. 100 AND 101). SN 77-396,015. PUB. 1-10-2012. FILED 2-13-2008.
- 4,116,605 (*See Class 9 for this trademark*).
- 4,116,610. **MEDRED (STANDARD CHARACTER)**. MEDRED, LLC, MULTIPLE CLASS, (INT. CLS. 42 AND 44), (U.S. CLS. 100 AND 101). SN 77-692,548. PUB. 1-19-2010. FILED 3-17-2009.
- 4,116,612 (*See Class 35 for this trademark*).
- 4,116,621. **HYDRAULIX (STANDARD CHARACTER)**. CAROLLO ENGINEERS, INC., (U.S. CLS. 100 AND 101). SN 77-773,569. PUB. 1-10-2012. FILED 7-2-2009.
- 4,116,631. **V VERIDIAN STRATEGIES AND DESIGN**. VERIDIAN STRATEGIES, LLC, (U.S. CLS. 100 AND 101). SN 77-819,146. PUB. 1-10-2012. FILED 9-3-2009.
- 4,116,636 (*See Class 9 for this trademark*).
- 4,116,675 (*See Class 1 for this trademark*).
- 4,116,678 (*See Class 1 for this trademark*).
- 4,116,686 (*See Class 9 for this trademark*).
- 4,116,688 (*See Class 7 for this trademark*).
- 4,116,705 (*See Class 35 for this trademark*).
- 4,116,708 (*See Class 6 for this trademark*).
- 4,116,712 (*See Class 10 for this trademark*).
- 4,116,713 (*See Class 9 for this trademark*).
- 4,116,718 (*See Class 10 for this trademark*).
- 4,116,761 (*See Class 7 for this trademark*).
- 4,116,763 (*See Class 16 for this trademark*).
- 4,116,764 (*See Class 9 for this trademark*).
- 4,116,767 (*See Class 16 for this trademark*).
- 4,116,775 (*See Class 9 for this trademark*).
- 4,116,793. **ZW (STYLIZED)**. BUSINESS OPPORTUNITY (BEIJING) NETWORK TECHNOLOGY CO., LTD, (U.S. CLS. 100 AND 101). SN 79-097,751. PUB. 1-10-2012. FILED 5-17-2011.
- 4,116,815 (*See Class 9 for this trademark*).
- 4,116,831 (*See Class 41 for this trademark*).
- 4,116,832 (*See Class 41 for this trademark*).
- 4,116,833 (*See Class 41 for this trademark*).
- 4,116,834 (*See Class 41 for this trademark*).
- 4,116,835 (*See Class 41 for this trademark*).
- 4,116,836 (*See Class 41 for this trademark*).
- 4,116,837 (*See Class 41 for this trademark*).
- 4,116,838 (*See Class 41 for this trademark*).
- 4,116,839 (*See Class 41 for this trademark*).
- 4,116,840 (*See Class 41 for this trademark*).
- 4,116,844 (*See Class 41 for this trademark*).

- 4,116,853 (*See Class 9 for this trademark.*)
 4,116,859 (*See Class 35 for this trademark.*)
 4,116,877 (*See Class 9 for this trademark.*)
 4,116,878 (*See Class 35 for this trademark.*)
 4,116,880 (*See Class 9 for this trademark.*)
 4,116,881 (*See Class 9 for this trademark.*)
 4,116,884 (*See Class 9 for this trademark.*)
 4,116,889 (*See Class 9 for this trademark.*)
 4,116,893. **COL RAMP (STANDARD CHARACTER)**. MEADOWBROOK, INC., (U.S. CLS. 100 AND 101). SN 85-051,274. PUB. 1-10-2012. FILED 5-31-2010.
 4,116,901. **VOSWATCHER (STANDARD CHARACTER)**. NICHOLAS OPARA, (U.S. CLS. 100 AND 101). SN 85-071,150. PUB. 1-10-2012. FILED 6-24-2010.
 4,116,909. **DIG MARKETING (STANDARD CHARACTER)**. DIG MARKETING, (U.S. CLS. 100 AND 101). SN 85-077,686. PUB. 1-10-2012. FILED 7-3-2010.
 4,116,915 (*See Class 9 for this trademark.*)
 4,116,945 (*See Class 35 for this trademark.*)
 4,116,947. **GQUEUES (STYLIZED)**. GQUEUES LLC, (U.S. CLS. 100 AND 101). SN 85-128,962. PUB. 1-10-2012. FILED 9-14-2010.
 4,116,956. **LANDSERVER (STANDARD CHARACTER)**. PINCHOT INSTITUTE FOR CONSERVATION, (U.S. CLS. 100 AND 101). SN 85-135,163. PUB. 1-10-2012. FILED 9-22-2010.
 4,116,958. **IM INCUMED (STYLIZED)**. INCUMED, INCORPORATED, (U.S. CLS. 100 AND 101). SN 85-136,912. PUB. 10-4-2011. FILED 9-23-2010.
 4,116,963 (*See Class 9 for this trademark.*)
 4,116,964. **FRESHBOOKS PAINLESS BILLING AND DESIGN**. 2NDSITE INC., (U.S. CLS. 100 AND 101). SN 85-144,923. PUB. 1-10-2012. FILED 10-5-2010.
 4,116,965. **MISCELLANEOUS DESIGN**. 2NDSITE INC., (U.S. CLS. 100 AND 101). SN 85-144,928. PUB. 1-10-2012. FILED 10-5-2010.
 4,116,980. **RECORD LINC (STANDARD CHARACTER)**. RODGERS III, JOSEPH, (U.S. CLS. 100 AND 101). SN 85-168,783. PUB. 1-10-2012. FILED 11-4-2010.
 4,116,982 (*See Class 36 for this trademark.*)
 4,116,987 (*See Class 41 for this trademark.*)
 4,116,991. **REPUTRACE (STANDARD CHARACTER)**. REPUTRACE INC., (U.S. CLS. 100 AND 101). SN 85-184,245. PUB. 1-10-2012. FILED 11-23-2010.
 4,116,996 (*See Class 35 for this trademark.*)
 4,116,997 (*See Class 10 for this trademark.*)
 4,117,013. **THE HUMILITY PROJECT (STANDARD CHARACTER)**. TOLEDO BABY, LLC, (U.S. CLS. 100 AND 101). SN 85-196,795. PUB. 1-10-2012. FILED 12-13-2010.
 4,117,039 (*See Class 35 for this trademark.*)
 4,117,043 (*See Class 40 for this trademark.*)
 4,117,070. **AGILIAN (STANDARD CHARACTER)**. AGILIAN, INC., (U.S. CLS. 100 AND 101). SN 85-220,919. PUB. 1-10-2012. FILED 1-19-2011.
 4,117,071. **PRICE PLUS INSIGHTS AND DESIGN**. WAKEFERN FOOD CORP., (U.S. CLS. 100 AND 101). SN 85-221,130. PUB. 1-10-2012. FILED 1-19-2011.
 4,117,093 (*See Class 25 for this trademark.*)
 4,117,161. **SHANE'S STUDIO (STANDARD CHARACTER)**. REILLY, SHANE, (U.S. CLS. 100 AND 101). SN 85-235,495. PUB. 1-10-2012. FILED 2-7-2011.
 4,117,165. **MISCELLANEOUS DESIGN**. KEYNETICS INC., (U.S. CLS. 100 AND 101). SN 85-235,766. PUB. 1-10-2012. FILED 2-7-2011.
 4,117,166 (*See Class 9 for this trademark.*)
 4,117,175 (*See Class 9 for this trademark.*)
 4,117,178. **THETRADE (STANDARD CHARACTER)**. PRITCHARD, JOSHUA, (U.S. CLS. 100 AND 101). SN 85-237,433. PUB. 1-10-2012. FILED 2-9-2011.
 4,117,192. **SCRUMWISE (STANDARD CHARACTER)**. SCRUMWISE APS, (U.S. CLS. 100 AND 101). SN 85-239,648. PUB. 1-10-2012. FILED 2-11-2011.
 4,117,225 (*See Class 9 for this trademark.*)
 4,117,232. **SAMPLECAM (STANDARD CHARACTER)**. SELMAN AND ASSOCIATES, LTD., (U.S. CLS. 100 AND 101). SN 85-246,376. PUB. 1-10-2012. FILED 2-18-2011.
 4,117,233 (*See Class 9 for this trademark.*)
 4,117,238. **SHARON NAGASSAR (STANDARD CHARACTER)**. SHARON NAGASSAR DESIGNS LLC, (U.S. CLS. 100 AND 101). SN 85-247,455. PUB. 1-10-2012. FILED 2-21-2011.
 4,117,252 (*See Class 9 for this trademark.*)
 4,117,261 (*See Class 37 for this trademark.*)
 4,117,265 (*See Class 35 for this trademark.*)
 4,117,266 (*See Class 35 for this trademark.*)
 4,117,293. **ACCELANCE (STANDARD CHARACTER)**. VISIONEDGE MARKETING, INC., (U.S. CLS. 100 AND 101). SN 85-259,528. PUB. 1-10-2012. FILED 3-7-2011.
 4,117,294. **AVANTAGE (STANDARD CHARACTER)**. VISIONEDGE MARKETING, INC., (U.S. CLS. 100 AND 101). SN 85-259,543. PUB. 1-10-2012. FILED 3-7-2011.
 4,117,313. **NODE.JS (STANDARD CHARACTER)**. JOYENT, INC., (U.S. CLS. 100 AND 101). SN 85-262,623. PUB. 1-10-2012. FILED 3-9-2011.
 4,117,315. **NORTHTOWN TESTING AND DESIGN**. STEEL AND PIPE SUPPLY COMPANY, INC., (U.S. CLS. 100 AND 101). SN 85-263,067. PUB. 1-10-2012. FILED S.R. 3-10-2011; AM. P.R. 11-4-2011.
 4,117,316. **VASCULAR QUALITY INITIATIVE (STANDARD CHARACTER)**. SOCIETY FOR VASCULAR SURGERY, MULTIPLE CLASS, (INT. CLS. 42 AND 44), (U.S. CLS. 100 AND 101). SN 85-263,294. PUB. 1-10-2012. FILED 3-10-2011.
 4,117,320. **PLUG & PROTECT (STANDARD CHARACTER)**. BOLSTER LLC, (U.S. CLS. 100 AND 101). SN 85-264,920. PUB. 1-10-2012. FILED 3-11-2011.
 4,117,328 (*See Class 41 for this trademark.*)
 4,117,357 (*See Class 9 for this trademark.*)
 4,117,370 (*See Class 35 for this trademark.*)
 4,117,371. **WITUNERS (STANDARD CHARACTER)**. QIAN LU, (U.S. CLS. 100 AND 101). SN 85-277,540. PUB. 1-10-2012. FILED 3-25-2011.
 4,117,381. **GULFSTUDY A HEALTH STUDY FOR OIL SPILL CLEAN-UP WORKERS AND VOLUNTEERS AND DESIGN**. U.S. DEPARTMENT OF HEALTH AND HUMAN SERVICES, (U.S. CLS. 100 AND 101). SN 85-279,896. PUB. 1-10-2012. FILED 3-29-2011.
 4,117,430 (*See Class 9 for this trademark.*)
 4,117,444 (*See Class 9 for this trademark.*)
 4,117,469. **CRESCENT CONSTRUCTION SERVICES (STANDARD CHARACTER)**. CRESCENT CONSTRUCTION SERVICES, LLC, DBA CRESCENT CONSTRUCTION SERVICES, (U.S. CLS. 100 AND 101). SN 85-295,515. PUB. 1-10-2012. FILED 4-14-2011.
 4,117,475. **MISCELLANEOUS DESIGN**. PROMETHEUS NEMESIS BOOK COMPANY, (U.S. CLS. 100 AND 101). SN 85-297,498. PUB. 1-10-2012. FILED 4-18-2011.
 4,117,489. **MISCELLANEOUS DESIGN**. SELMAN AND ASSOCIATES, LTD., (U.S. CLS. 100 AND 101). SN 85-300,168. PUB. 1-10-2012. FILED 4-20-2011.
 4,117,495. **MERCURY NETWORK (STANDARD CHARACTER)**. A LA MODE, INC., (U.S. CLS. 100 AND 101). SN 85-301,328. PUB. 1-10-2012. FILED 4-21-2011.
 4,117,512 (*See Class 35 for this trademark.*)
 4,117,544. **INCAPSULA (STANDARD CHARACTER)**. INCAPSULA, INC., MULTIPLE CLASS, (INT. CLS. 42 AND 45), (U.S. CLS. 100 AND 101). SN 85-311,917. PUB. 1-10-2012. FILED 5-4-2011.
 4,117,547. **ARTSORGANISM (STANDARD CHARACTER)**. ARTSORGANISM, INC., (U.S. CLS. 100 AND 101). SN 85-313,595. PUB. 1-10-2012. FILED 5-5-2011.
 4,117,567. **BENCHMARK CONNECTIONS AND DESIGN**. BENCHMARK SENIOR LIVING, (U.S. CLS. 100 AND 101). SN 85-318,011. PUB. 1-10-2012. FILED 5-11-2011.
 4,117,568. **BENCHMARK CONNECTIONS AND DESIGN**. BENCHMARK SENIOR LIVING, (U.S. CLS. 100 AND 101). SN 85-318,026. PUB. 1-10-2012. FILED 5-11-2011.
 4,117,579. **HOW'S THE MARKET? (STANDARD CHARACTER)**. ALTOS RESEARCH, LLC, (U.S. CLS. 100 AND 101). SN 85-320,895. PUB. 1-10-2012. FILED 5-13-2011.
 4,117,595 (*See Class 9 for this trademark.*)
 4,117,611. **MISCELLANEOUS DESIGN**. VANCO OVERSEAS ENERGY LIMITED, (U.S. CLS. 100 AND 101). SN 85-325,243. PUB. 1-10-2012. FILED 5-19-2011.
 4,117,622 (*See Class 9 for this trademark.*)
 4,117,656. **SHAFFER PRODUCTIONS AND DESIGN**. SHAFFER, TODD, (U.S. CLS. 100 AND 101). SN 85-334,921. PUB. 1-10-2012. FILED 6-1-2011.

- 4,117,658 (*See Class 9 for this trademark*).
- 4,117,669. **WOVENMEDIA (STYLIZED)**. WOVENMEDIA, INC., (U.S. CLS. 100 AND 101). SN 85-336,703. PUB. 1-10-2012. FILED 6-2-2011.
- 4,117,679. **AMF ALFRED MANN FOUNDATION AND DESIGN**. THE ALFRED E. MANN FOUNDATION FOR SCIENTIFIC RESEARCH, (U.S. CLS. 100 AND 101). SN 85-339,745. PUB. 1-10-2012. FILED 6-7-2011.
- 4,117,702. **ASTRAL COMPUTING (STANDARD CHARACTER)**. WILLIAMS JR., WALTER F., DBA ASTRAL COMPUTING, (U.S. CLS. 100 AND 101). SN 85-344,512. PUB. 1-10-2012. FILED 6-13-2011.
- 4,117,715. **ILEGRA (STANDARD CHARACTER)**. ILEGRA CORP., (U.S. CLS. 100 AND 101). SN 85-347,015. PUB. 1-10-2012. FILED 6-15-2011.
- 4,117,721. **TDC THE DESIGN CLUB AND DESIGN**. THE DESIGN CLUB INC., (U.S. CLS. 100 AND 101). SN 85-347,893. PUB. 1-10-2012. FILED 6-16-2011.
- 4,117,739 (*See Class 35 for this trademark*).
- 4,117,752. **LATINA SMART (STANDARD CHARACTER)**. SEARS BRANDS, LLC, (U.S. CLS. 100 AND 101). SN 85-351,772. PUB. 1-10-2012. FILED 6-21-2011.
- 4,117,766 (*See Class 35 for this trademark*).
- 4,117,774. **GEN-ACTIVE TECHNOLOGY (STANDARD CHARACTER)**. PRINCE AGRI PRODUCTS, INC., (U.S. CLS. 100 AND 101). SN 85-354,518. PUB. 1-10-2012. FILED 6-23-2011.
- 4,117,787 (*See Class 9 for this trademark*).
- 4,117,818. **THE CONLEY INDEX (STANDARD CHARACTER)**. CONLEY, PAUL F., (U.S. CLS. 100 AND 101). SN 85-360,257. PUB. 1-10-2012. FILED 6-30-2011.
- 4,117,821. **SFI SFI FOUNDATION, INC. AND DESIGN**. SFI FOUNDATION, INC., (U.S. CLS. 100 AND 101). SN 85-360,324. PUB. 1-10-2012. FILED 6-30-2011.
- 4,117,836. **TEXT MY AUTO (STANDARD CHARACTER)**. MASTER MY MARKETING, LLC, (U.S. CLS. 100 AND 101). SN 85-362,961. PUB. 1-10-2012. FILED 7-5-2011.
- 4,117,837. **BLOGTACULOUS (STANDARD CHARACTER)**. FIELD IV, GEORGE ADDISON, (U.S. CLS. 100 AND 101). SN 85-362,980. PUB. 1-10-2012. FILED 7-5-2011.
- 4,117,868. **COMERICA BUSINESS DEPOSIT CAPTURE (STANDARD CHARACTER)**. COMERICA INCORPORATED, (U.S. CLS. 100 AND 101). SN 85-365,411. PUB. 1-10-2012. FILED 7-7-2011.
- 4,117,873 (*See Class 35 for this trademark*).
- 4,117,875. **BRAINMONKEY AND DESIGN**. 256 CORPORATION, (U.S. CLS. 100 AND 101). SN 85-365,890. PUB. 1-10-2012. FILED 7-7-2011.
- 4,117,892 (*See Class 35 for this trademark*).
- 4,117,898 (*See Class 35 for this trademark*).
- 4,117,912. **DIAMOND DESIGN (STANDARD CHARACTER)**. GUESTSHOTS, INC., (U.S. CLS. 100 AND 101). SN 85-368,149. PUB. 1-10-2012. FILED 7-11-2011.
- 4,117,922 (*See Class 35 for this trademark*).
- 4,117,926. **ACCESS INTELLIGENCE THE SMART CONNECTION AND DESIGN**. ACCESS INTELLIGENCE, INC., (U.S. CLS. 100 AND 101). SN 85-368,867. PUB. 1-10-2012. FILED 7-12-2011.
- 4,117,932. **ELEVATE YOUR RESEARCH (STANDARD CHARACTER)**. R&D CLOUD, INC., (U.S. CLS. 100 AND 101). SN 85-369,050. PUB. 1-10-2012. FILED 7-12-2011.
- 4,117,933. **MISCELLANEOUS DESIGN**. R&D CLOUD, INC., (U.S. CLS. 100 AND 101). SN 85-369,064. PUB. 1-10-2012. FILED 7-12-2011.
- 4,118,020. **SPRINGCM AND DESIGN**. SPRINGCM INC., (U.S. CLS. 100 AND 101). SN 85-372,364. PUB. 1-10-2012. FILED 7-15-2011.
- 4,118,064. **RIVET SYSTEMS AND DESIGN**. RIVET SYSTEMS INCORPORATED, (U.S. CLS. 100 AND 101). SN 85-373,631. PUB. 1-10-2012. FILED 7-18-2011.
- 4,118,079. **UPLAND DESIGN AND DESIGN**. UPLAND DESIGN, LTD., (U.S. CLS. 100 AND 101). SN 85-373,920. PUB. 1-10-2012. FILED 7-18-2011.
- 4,118,103. **BUUTEEQ (STANDARD CHARACTER)**. BUUTEEQ, INC., (U.S. CLS. 100 AND 101). SN 85-374,386. PUB. 1-10-2012. FILED 7-18-2011.
- 4,118,108. **HISTORYMINDERS (STANDARD CHARACTER)**. THE TRUSTEE OF THE MICHAEL H. COON REVOCABLE TRUST, (U.S. CLS. 100 AND 101). SN 85-374,497. PUB. 1-10-2012. FILED 7-19-2011.
- 4,118,110. **MONTURA (STANDARD CHARACTER)**. GRAHAM, KEVIN, (U.S. CLS. 100 AND 101). SN 85-374,575. PUB. 1-10-2012. FILED 7-19-2011.
- 4,118,125. **DOODLELY AND DESIGN**. NIGHT INCUBATOR LLC, (U.S. CLS. 100 AND 101). SN 85-374,930. PUB. 1-10-2012. FILED 7-19-2011.
- 4,118,130. **YOULAWS (STANDARD CHARACTER)**. RIVERS, KYLE E, (U.S. CLS. 100 AND 101). SN 85-375,056. PUB. 1-10-2012. FILED 7-19-2011.
- 4,118,169. **GREENBRIDGE COMPUTING (STANDARD CHARACTER)**. GREENBRIDGE COMPUTING, INC., (U.S. CLS. 100 AND 101). SN 85-375,615. PUB. 1-10-2012. FILED 7-19-2011.
- 4,118,183 (*See Class 38 for this trademark*).
- 4,118,203 (*See Class 37 for this trademark*).
- 4,118,204 (*See Class 37 for this trademark*).
- 4,118,205. **IT PREVENT (STANDARD CHARACTER)**. INTEGRATECHS, INC., (U.S. CLS. 100 AND 101). SN 85-376,837. PUB. 1-10-2012. FILED 7-21-2011.
- 4,118,206. **IT EXTREME (STANDARD CHARACTER)**. INTEGRATECHS, INC., (U.S. CLS. 100 AND 101). SN 85-376,841. PUB. 1-10-2012. FILED 7-21-2011.
- 4,118,211. **QUIKSITE (STANDARD CHARACTER)**. ZENOVA CORP., (U.S. CLS. 100 AND 101). SN 85-377,298. PUB. 1-10-2012. FILED 7-21-2011.
- 4,118,223 (*See Class 35 for this trademark*).
- 4,118,234. **IMPACT ANALYTICAL (STANDARD CHARACTER)**. MICHIGAN MOLECULAR INSTITUTE, DBA IMPACT ANALYTICAL, (U.S. CLS. 100 AND 101). SN 85-377,833. PUB. 1-10-2012. FILED 7-21-2011.
- 4,118,235 (*See Class 35 for this trademark*).
- 4,118,236 (*See Class 9 for this trademark*).
- 4,118,248 (*See Class 35 for this trademark*).
- 4,118,258. **Q-PLUS LABS (STANDARD CHARACTER)**. Q-PLUS LABS, A QPL TECHNOLOGIES, INC. COMPANY, (U.S. CLS. 100 AND 101). SN 85-379,033. PUB. 1-10-2012. FILED 7-22-2011.
- 4,118,280 (*See Class 35 for this trademark*).
- 4,118,295. **KG KAMA GAMES AND DESIGN**. KAMAGAMES LTD, (U.S. CLS. 100 AND 101). SN 85-381,439. PUB. 1-10-2012. FILED 7-26-2011.
- 4,118,296. **KAMA GAMES (STANDARD CHARACTER)**. KAMAGAMES LTD, (U.S. CLS. 100 AND 101). SN 85-381,465. PUB. 1-10-2012. FILED 7-26-2011.
- 4,118,344 (*See Class 35 for this trademark*).
- 4,118,345 (*See Class 36 for this trademark*).
- 4,118,347 (*See Class 36 for this trademark*).
- 4,118,348. **MISCELLANEOUS DESIGN**. VIZIBILITY INC., (U.S. CLS. 100 AND 101). SN 85-389,291. PUB. 1-10-2012. FILED 8-4-2011.
- 4,118,392 (*See Class 41 for this trademark*).
- 4,118,402. **HRI (STANDARD CHARACTER)**. HEALTH RESEARCH, INC., (U.S. CLS. 100 AND 101). SN 85-392,246. PUB. 1-10-2012. FILED 8-8-2011.
- 4,118,405. **AKONNA (STANDARD CHARACTER)**. AKONNA, INC., (U.S. CLS. 100 AND 101). SN 85-392,313. PUB. 1-10-2012. FILED 8-8-2011.
- 4,118,406. **MISCELLANEOUS DESIGN**. SPRINGCM INC., (U.S. CLS. 100 AND 101). SN 85-392,400. PUB. 1-10-2012. FILED 8-8-2011.
- 4,118,412. **NOVA ECLIPSE (STANDARD CHARACTER)**. WESSELS, JEREMIAH RAY, AKA J.R. WESSELS, (U.S. CLS. 100 AND 101). SN 85-392,460. PUB. 1-10-2012. FILED 8-8-2011.
- 4,118,420. **FUNNY2 (STYLIZED)**. FUNNY2, INC., (U.S. CLS. 100 AND 101). SN 85-392,665. PUB. 1-10-2012. FILED 8-8-2011.
- 4,118,433. **WHO IS YOUR INSURANCE (STANDARD CHARACTER)**. WHO IS YOUR INSURANCE, INC., (U.S. CLS. 100 AND 101). SN 85-393,016. PUB. 1-10-2012. FILED 8-9-2011.
- 4,118,521 (*See Class 35 for this trademark*).
- 4,118,545 (*See Class 35 for this trademark*).
- 4,118,559. **SMOKESIGNAL AND DESIGN**. SALE SIGNAL, LLC, (U.S. CLS. 100 AND 101). SN 85-395,414. PUB. 1-10-2012. FILED 8-11-2011.
- 4,118,598. **TRU:INFORM (STANDARD CHARACTER)**. INTELMEDIX LLC, AKA IMX, (U.S. CLS. 100 AND 101). SN 85-396,075. PUB. 1-10-2012. FILED 8-11-2011.

- 4,118,614. **CHOP (STANDARD CHARACTER)**. ZURB, INC., (U.S. CLS. 100 AND 101). SN 85-396,593. PUB. 1-10-2012. FILED 8-12-2011.
- 4,118,615. **RTKL AND DESIGN**. RTKL ASSOCIATES, INC., (U.S. CLS. 100 AND 101). SN 85-396,608. PUB. 1-10-2012. FILED 8-12-2011.
- 4,118,656. **JABIAN (STANDARD CHARACTER)**. JABIAN, LLC, (U.S. CLS. 100 AND 101). SN 85-397,269. PUB. 1-10-2012. FILED 8-13-2011.
- 4,118,659. **STRATEGY THAT WORKS (STANDARD CHARACTER)**. JABIAN, LLC, (U.S. CLS. 100 AND 101). SN 85-397,273. PUB. 1-10-2012. FILED 8-13-2011.
- 4,118,686 (*See Class 35 for this trademark*).
- 4,118,691. **SIGNATURE (STANDARD CHARACTER)**. FISERV, INC., (U.S. CLS. 100 AND 101). SN 85-412,638. PUB. 1-10-2012. FILED 9-1-2011.
- 4,118,696. **TECHMEME (STANDARD CHARACTER)**. EPIVOZ CORPORATION, (U.S. CLS. 100 AND 101). SN 85-419,540. PUB. 1-10-2012. FILED 9-10-2011.
- 4,118,700. **BIT THEORY. INC AND DESIGN**. BIT THEORY, INC., (U.S. CLS. 100 AND 101). SN 85-424,702. PUB. 1-10-2012. FILED 9-16-2011.
- 4,118,707. **BIT THEORY, INC. (STANDARD CHARACTER)**. BIT THEORY, INC., (U.S. CLS. 100 AND 101). SN 85-428,715. PUB. 1-10-2012. FILED 9-21-2011.
- 4,118,726 (*See Class 1 for this trademark*).
- 4,118,733. **LOWERCASE (STANDARD CHARACTER)**. LOWERCASE, INC., (U.S. CLS. 100 AND 101). SN 85-456,145. PUB. 1-10-2012. FILED 10-25-2011.

CLASS 43—HOTEL AND RESTAURANT SERVICES

- 4,116,608 (*See Class 36 for this trademark*).
- 4,116,616 (*See Class 16 for this trademark*).
- 4,116,648. **DJ'S TASTE OF THE 50'S (STANDARD CHARACTER)**. SPARK ASSOCIATES INC., (U.S. CLS. 100 AND 101). SN 77-907,759. PUB. 6-1-2010. FILED 1-8-2010.
- 4,116,649. **DJ'S TASTE OF THE 50'S BREAKFAST BURGERS - FRIES SUNDAES SHAKES AND DESIGN**. SPARK ASSOCIATES INC., (U.S. CLS. 100 AND 101). SN 77-907,770. PUB. 6-1-2010. FILED 1-8-2010.
- 4,116,656 (*See Class 41 for this trademark*).
- 4,116,701. **BE LIVE (STANDARD CHARACTER)**. GLOBALIA EXPLOTACIONES HOTELERAS, S.L., (U.S. CLS. 100 AND 101). SN 79-086,306. PUB. 1-10-2012. FILED 7-26-2010.
- 4,116,702 (*See Class 16 for this trademark*).
- 4,116,726 (*See Class 16 for this trademark*).
- 4,116,776 (*See Class 35 for this trademark*).
- 4,116,806 (*See Class 39 for this trademark*).
- 4,116,914 (*See Class 41 for this trademark*).
- 4,117,002. **MISCELLANEOUS DESIGN**. CRO-BAR, L.L.C., (U.S. CLS. 100 AND 101). SN 85-190,959. PUB. 1-10-2012. FILED 12-6-2010.
- 4,117,061. **THE NURTURING NOOK (STANDARD CHARACTER)**. THE NURTURING NOOK, INC., MULTIPLE CLASS, (INT. CLS. 43 AND 45), (U.S. CLS. 100 AND 101). SN 85-219,152. PUB. 1-10-2012. FILED 1-17-2011.
- 4,117,063 (*See Class 35 for this trademark*).
- 4,117,074 (*See Class 25 for this trademark*).
- 4,117,127 (*See Class 36 for this trademark*).
- 4,117,158. **STRAW CARNIVAL FARE AND DESIGN**. LIVE AWAKE LLC, (U.S. CLS. 100 AND 101). SN 85-235,176. PUB. 1-10-2012. FILED 2-6-2011.
- 4,117,162. **MISCELLANEOUS DESIGN**. A PLACE TO GROW, INC., (U.S. CLS. 100 AND 101). SN 85-235,580. PUB. 1-10-2012. FILED 2-7-2011.
- 4,117,163. **A . PLACE . TO . GROW AND DESIGN**. A PLACE TO GROW, INC., (U.S. CLS. 100 AND 101). SN 85-235,616. PUB. 1-10-2012. FILED 2-7-2011.
- 4,117,198 (*See Class 3 for this trademark*).
- 4,117,229 (*See Class 41 for this trademark*).
- 4,117,239. **. GBC . GOURMET BURGER COMPANY AND DESIGN**. GUASCH CACERES, LUIS ALBERTO, (U.S. CLS. 100 AND 101). SN 85-247,517. PUB. 1-10-2012. FILED 2-21-2011.
- 4,117,254. **PERQS COFFEE SERVICE PERQ (PERK): BENEFIT QUALITY (STYLIZED)**. THE QUALITY COMPANIES, INC., (U.S. CLS. 100 AND 101). SN 85-249,714. PUB. 1-10-2012. FILED 2-23-2011.
- 4,117,310. **HOT BOX GRILL (STANDARD CHARACTER)**. HOT BOX GRILL, LLC, (U.S. CLS. 100 AND 101). SN 85-261,683. PUB. 1-10-2012. FILED 3-9-2011.
- 4,117,397. **BURGERIA (STANDARD CHARACTER)**. JOSEPH CIOLLI, (U.S. CLS. 100 AND 101). SN 85-281,790. PUB. 1-10-2012. FILED 3-30-2011.
- 4,117,436. **EAST COAST WINGS & GRILL FEEL THE FLAVOR TASTE THE HEAT AND DESIGN**. EAST COAST WINGS CORPORATION, (U.S. CLS. 100 AND 101). SN 85-291,023. PUB. 1-10-2012. FILED 4-9-2011.
- 4,117,438 (*See Class 35 for this trademark*).
- 4,117,441. **EAST COAST WINGS & GRILL ON THE GO AND DESIGN**. EAST COAST WINGS CORPORATION, (U.S. CLS. 100 AND 101). SN 85-291,575. PUB. 1-10-2012. FILED 4-11-2011.
- 4,117,477 (*See Class 25 for this trademark*).
- 4,117,535. **THE ORIGINAL MAXWELL STREET POLISH SAUSAGE STAND (STANDARD CHARACTER)**. JIM'S ORIGINAL INCORPORATED, (U.S. CLS. 100 AND 101). SN 85-310,313. PUB. 1-10-2012. FILED 5-2-2011.
- 4,117,584. **LUM KA NAAD NORTHERN & SOUTHERN THAI CUISINES AND DESIGN**. LUM KA NAAD THAI CUISINE RESTAURANTS, DBA LUM KA NAAD THAI CUISINE RESTAURANTS, (U.S. CLS. 100 AND 101). SN 85-322,242. PUB. 1-10-2012. FILED 5-16-2011.
- 4,117,590 (*See Class 25 for this trademark*).
- 4,117,603. **MISCELLANEOUS DESIGN**. CHARITY AND PRUDENCE, LLC, AKA GURU'S, (U.S. CLS. 100 AND 101). SN 85-324,361. PUB. 1-10-2012. FILED 5-18-2011.
- 4,117,654. **AMERICAN KIDZ ACADEMY AND DESIGN**. KIDZ ACADEMY, LLC, (U.S. CLS. 100 AND 101). SN 85-334,562. PUB. 1-10-2012. FILED 5-31-2011.
- 4,117,655. **ELITE URBAN EDUCATION (STANDARD CHARACTER)**. KIDZ ACADEMY, LLC, (U.S. CLS. 100 AND 101). SN 85-334,600. PUB. 1-10-2012. FILED 5-31-2011.
- 4,117,764. **LA COSTA COASTAL EVENTS CENTER (STANDARD CHARACTER)**. FILLMORE LC HOLDINGS I, LLC, (U.S. CLS. 100 AND 101). SN 85-353,561. PUB. 1-10-2012. FILED 6-22-2011.
- 4,117,765. **THE COASTAL EVENTS CENTER AT LA COSTA (STANDARD CHARACTER)**. FILLMORE LC HOLDINGS I, LLC, (U.S. CLS. 100 AND 101). SN 85-353,572. PUB. 1-10-2012. FILED 6-22-2011.
- 4,117,773. **SAN DIEGO-STYLE SOMBRERO MEXICAN FOOD AND DESIGN**. CORREA MANAGEMENT, INC., DBA SOMBRERO MEXICAN FOOD, (U.S. CLS. 100 AND 101). SN 85-354,290. PUB. 1-10-2012. FILED 6-23-2011.
- 4,117,905. **SPORTS WITH A VIEW (STANDARD CHARACTER)**. BIKINS BAR AND GRILL LLC, (U.S. CLS. 100 AND 101). SN 85-367,507. PUB. 1-10-2012. FILED 7-10-2011.
- 4,117,908 (*See Class 36 for this trademark*).
- 4,117,940. **TAMS BURGERS (STANDARD CHARACTER)**. LONG BEACH BOULEVARD BURGERS, INC., (U.S. CLS. 100 AND 101). SN 85-369,290. PUB. 1-10-2012. FILED 7-12-2011.
- 4,117,953. **TIMBERLAKE LODGE (STANDARD CHARACTER)**. GRAND HOSPITALITY LLC, (U.S. CLS. 100 AND 101). SN 85-369,905. PUB. 1-10-2012. FILED 7-13-2011.
- 4,117,954. **MICHAEL'S HOUSE BOUTIQUE AND DESIGN**. MICHAEL Z. WANG, (U.S. CLS. 100 AND 101). SN 85-369,914. PUB. 1-10-2012. FILED 7-13-2011.
- 4,117,987. **ROCK CREEK PIZZA DOUGH CO. AND DESIGN**. ROCK CREEK PIZZA DOUGH CO., (U.S. CLS. 100 AND 101). SN 85-371,230. PUB. 1-10-2012. FILED 7-14-2011.
- 4,117,997. **CITY SMOKE HOUSE (STANDARD CHARACTER)**. CITY SMOKE HOUSE, (U.S. CLS. 100 AND 101). SN 85-371,598. PUB. 1-10-2012. FILED 7-14-2011.
- 4,118,045. **ITRIYA CAFE SPAGHETTI & SSAM AND DESIGN**. GORDON RESTAURANT GROUP, LLC, (U.S. CLS. 100 AND 101). SN 85-373,099. PUB. 1-10-2012. FILED 7-16-2011.
- 4,118,054. **THE OSTHOFF RESORT (STANDARD CHARACTER)**. OSTHOFF MANAGEMENT CORP., (U.S. CLS. 100 AND 101). SN 85-373,514. PUB. 1-10-2012. FILED 7-18-2011.
- 4,118,055. **THE OSTHOFF RESORT AND DESIGN**. OSTHOFF

- MANAGEMENT CORP., (U.S. CLS. 100 AND 101). SN 85-373,529. PUB. 1-10-2012. FILED 7-18-2011.
- 4,118,059. **FOOD FOR THOUGHT CATERING AND DESIGN.** ALVAREZ, JAMES, (U.S. CLS. 100 AND 101). SN 85-373,606. PUB. 1-10-2012. FILED 7-18-2011.
- 4,118,061. **THE OSTHOFF RESORT YOUR PLACE ON THE LAKE AND DESIGN.** OSTHOFF MANAGEMENT CORP., (U.S. CLS. 100 AND 101). SN 85-373,616. PUB. 1-10-2012. FILED 7-18-2011.
- 4,118,074. **CORNUTO (STANDARD CHARACTER).** MCCONNELL, MICHAEL, (U.S. CLS. 100 AND 101). SN 85-373,826. PUB. 1-10-2012. FILED 7-18-2011.
- 4,118,080. **HOPS & PIE ARTISAN PIZZERIA AND CRAFT BREW TAP ROOM AND DESIGN.** HOPS & PIE, (U.S. CLS. 100 AND 101). SN 85-373,984. PUB. 1-10-2012. FILED 7-18-2011.
- 4,118,083. **MEXICO LINDO (STANDARD CHARACTER).** CASTRO, JUAN MANUEL, DBA MEXICO LINDO & SEAFOOD RESTAURANT, (U.S. CLS. 100 AND 101). SN 85-374,075. PUB. 1-10-2012. FILED 7-18-2011.
- 4,118,085. **BOMBAY CHOPSTIX (STANDARD CHARACTER).** WORLD ONE CUISINE TEXAS LLC, (U.S. CLS. 100 AND 101). SN 85-374,142. PUB. 1-10-2012. FILED 7-18-2011.
- 4,118,176. **JOE KOOL'S (STANDARD CHARACTER).** TROY SPORTS RESTAURANT, LLC, DBA JOE KOOL'S BAR & RESTAURANT, (U.S. CLS. 100 AND 101). SN 85-375,798. PUB. 1-10-2012. FILED 7-20-2011.
- 4,118,178. **PITA BROTHERS (STANDARD CHARACTER).** MOTOVEND, LLC, (U.S. CLS. 100 AND 101). SN 85-375,848. PUB. 1-10-2012. FILED 7-20-2011.
- 4,118,197. **SAN PEDRO FISH MARKET PORTS O'CALL VILLAGE AND DESIGN.** SAN PEDRO FISH MARKET ENTERPRISES, INC., (U.S. CLS. 100 AND 101). SN 85-376,749. PUB. 1-10-2012. FILED 7-20-2011.
- 4,118,199 (*See Class 25 for this trademark*).
- 4,118,201. **BOMBAY CHOP STIX AND DESIGN.** WORLD ONE CUISINE TEXAS LLC, (U.S. CLS. 100 AND 101). SN 85-376,801. PUB. 1-10-2012. FILED 7-20-2011.
- 4,118,209. **TWO BOOTS (STANDARD CHARACTER).** PHILIP HARTMAN, (U.S. CLS. 100 AND 101). SN 85-377,193. PUB. 1-10-2012. FILED 7-21-2011.
- 4,118,219. **S SWEETOME HOTELS + RESORTS AND DESIGN.** C-TRAVEL INTERNATIONAL LIMITED, (U.S. CLS. 100 AND 101). SN 85-377,554. PUB. 1-10-2012. FILED 7-21-2011.
- 4,118,220. **TWO BOOTS AND DESIGN.** PHILIP HARTMAN, (U.S. CLS. 100 AND 101). SN 85-377,593. PUB. 1-10-2012. FILED 7-21-2011.
- 4,118,231. **HERITAGE RESTAURANTS (STANDARD CHARACTER).** HERITAGE RESTAURANTS LLC, (U.S. CLS. 100 AND 101). SN 85-377,784. PUB. 1-10-2012. FILED 7-21-2011.
- 4,118,328. **THE GIN JOINT AND DESIGN.** GRAND CREW, LLC, DBA THE GIN JOINT, (U.S. CLS. 100 AND 101). SN 85-388,060. PUB. 1-10-2012. FILED 8-3-2011.
- 4,118,332. **AN OFF BROADWAY HIT SINCE 1944! (STANDARD CHARACTER).** PATSY'S BRAND, INC., (U.S. CLS. 100 AND 101). SN 85-388,161. PUB. 1-10-2012. FILED 8-3-2011.
- 4,118,340 (*See Class 29 for this trademark*).
- 4,118,397. **WE LOCALS AND DESIGN.** NP IP HOLDINGS LLC, (U.S. CLS. 100 AND 101). SN 85-392,155. PUB. 1-10-2012. FILED 8-8-2011.
- 4,118,399 (*See Class 30 for this trademark*).
- 4,118,456. **ROSE LANE (STANDARD CHARACTER).** KAPLAN DEVELOPMENT GROUP, LLC, (U.S. CLS. 100 AND 101). SN 85-393,307. PUB. 1-10-2012. FILED 8-9-2011.
- 4,118,550. **ABBAY'S AND DESIGN.** ABBAYHYDE, LLC, (U.S. CLS. 100 AND 101). SN 85-395,301. PUB. 1-10-2012. FILED 8-11-2011.
- 4,118,568. **MAKE EVERY DAY DELICIOUS (STANDARD CHARACTER).** MARA'S SYSTEMS LLC, (U.S. CLS. 100 AND 101). SN 85-395,685. PUB. 1-10-2012. FILED 8-11-2011.
- 4,118,580. **CATCH IT ON THE FLY (STANDARD CHARACTER).** MRPCO, LLC, (U.S. CLS. 100 AND 101). SN 85-395,807. PUB. 1-10-2012. FILED 8-11-2011.
- 4,118,605. **KERBEY LANE CAFE AND DESIGN.** KERBEY LANE CAFE, INC., (U.S. CLS. 100 AND 101). SN 85-396,310. PUB. 1-10-2012. FILED 8-12-2011.
- 4,118,606. **KERBEY LANE CATERING AND DESIGN.** KERBEY LANE CAFE, INC., (U.S. CLS. 100 AND 101). SN 85-396,311. PUB. 1-10-2012. FILED 8-12-2011.
- 4,118,635. **HI-NEW YORK (STANDARD CHARACTER).** AMERICAN YOUTH HOSTELS, INC., DBA HOSTELLING INTERNATIONAL USA, (U.S. CLS. 100 AND 101). SN 85-396,961. PUB. 1-10-2012. FILED 8-12-2011.
- 4,118,637. **HI-WASHINGTON DC (STANDARD CHARACTER).** AMERICAN YOUTH HOSTELS, INC., DBA HOSTELLING INTERNATIONAL USA, (U.S. CLS. 100 AND 101). SN 85-397,010. PUB. 1-10-2012. FILED 8-12-2011.
- 4,118,639. **HI-CHICAGO (STANDARD CHARACTER).** AMERICAN YOUTH HOSTELS, INC., DBA HOSTELLING INTERNATIONAL USA, (U.S. CLS. 100 AND 101). SN 85-397,028. PUB. 1-10-2012. FILED 8-12-2011.
- 4,118,644. **HI-AUSTIN (STANDARD CHARACTER).** AMERICAN YOUTH HOSTELS, INC., DBA HOSTELLING INTERNATIONAL USA, (U.S. CLS. 100 AND 101). SN 85-397,065. PUB. 1-10-2012. FILED 8-12-2011.
- 4,118,648. **HI-HOUSTON (STANDARD CHARACTER).** AMERICAN YOUTH HOSTELS, INC., DBA HOSTELLING INTERNATIONAL USA, (U.S. CLS. 100 AND 101). SN 85-397,109. PUB. 1-10-2012. FILED 8-12-2011.
- 4,118,664. **G-BUCKS (STANDARD CHARACTER).** PACIFIC REPUBLIC, INC., (U.S. CLS. 100 AND 101). SN 85-397,619. PUB. 1-10-2012. FILED 8-15-2011.
- 4,118,668. **A KID OR A KILLER (STANDARD CHARACTER).** DIVINE INHERITANCE, INC., (U.S. CLS. 100 AND 101). SN 85-400,974. PUB. 1-10-2012. FILED 8-18-2011.
- 4,118,669. **HI-BOSTON (STANDARD CHARACTER).** AMERICAN YOUTH HOSTELS, INC., DBA HOSTELLING INTERNATIONAL USA, (U.S. CLS. 100 AND 101). SN 85-401,234. PUB. 1-10-2012. FILED 8-18-2011.
- 4,118,680. **METLIFE STADIUM (STANDARD CHARACTER).** METROPOLITAN LIFE INSURANCE COMPANY, (U.S. CLS. 100 AND 101). SN 85-405,223. PUB. 1-10-2012. FILED 8-23-2011.
- 4,118,685. **METLIFE STADIUM AND DESIGN.** METROPOLITAN LIFE INSURANCE COMPANY, (U.S. CLS. 100 AND 101). SN 85-408,394. PUB. 1-10-2012. FILED 8-26-2011.
- 4,118,728. **BLITZED (STANDARD CHARACTER).** HRHH IP, LLC, (U.S. CLS. 100 AND 101). SN 85-446,826. PUB. 1-10-2012. FILED 10-13-2011.
- 4,118,731. **THE GREEN PARROT BAR (STANDARD CHARACTER).** MAYAN PARROT, LLC, DBA GREEN PARROT BAR, (U.S. CLS. 100 AND 101). SN 85-455,480. PUB. 1-10-2012. FILED 10-25-2011.

CLASS 44—MEDICAL, BEAUTY AND AGRICULTURAL SERVICES

- 4,116,576 (*See Class 35 for this trademark*).
- 4,116,608 (*See Class 36 for this trademark*).
- 4,116,610 (*See Class 42 for this trademark*).
- 4,116,632 (*See Class 41 for this trademark*).
- 4,116,685 (*See Class 10 for this trademark*).
- 4,116,735 (*See Class 5 for this trademark*).
- 4,116,808 (*See Class 16 for this trademark*).
- 4,116,885 (*See Class 9 for this trademark*).
- 4,116,990 (*See Class 29 for this trademark*).
- 4,117,009 (*See Class 41 for this trademark*).
- 4,117,063 (*See Class 35 for this trademark*).
- 4,117,076. **PREFERRED DENTAL CARE AND DESIGN.** SAAHIL DENTAL P.C., DBA PREFERRED DENTAL CARE, (U.S. CLS. 100 AND 101). SN 85-221,808. PUB. 1-10-2012. FILED 1-20-2011.
- 4,117,112. **MISCELLANEOUS DESIGN.** ROBIN'S NEST MOBILE DIAGNOSTICS, LLC, (U.S. CLS. 100 AND 101). SN 85-228,966. PUB. 1-10-2012. FILED 1-28-2011.
- 4,117,113 (*See Class 41 for this trademark*).
- 4,117,122. **ASSISTED RECOVERY CENTERS OF AMERICA (STANDARD CHARACTER).** ASSISTED RECOVERY CENTERS OF AMERICA, AKA ARCA, (U.S. CLS. 100 AND 101). SN 85-230,685. PUB. 1-10-2012. FILED 1-31-2011.
- 4,117,127 (*See Class 36 for this trademark*).
- 4,117,150. **SOBER LIVING BY THE SEA (STANDARD CHAR-**

- ACTER). CRC HEALTH CORPORATION, (U.S. CLS. 100 AND 101). SN 85-233,860. PUB. 1-10-2012. FILED 2-3-2011.
- 4,117,198 (*See Class 3 for this trademark*).
- 4,117,229 (*See Class 41 for this trademark*).
- 4,117,235. UNION SQUARE EYE CARE AND DESIGN. UNION SQUARE EYE CARE LLC, (U.S. CLS. 100 AND 101). SN 85-246,694. PUB. 1-10-2012. FILED 2-18-2011.
- 4,117,296. ADVANCED PROSTATE CANCER INSTITUTE AND DESIGN. CENTRAL FLORIDA UROLOGY SPECIALISTS, LLC, (U.S. CLS. 100 AND 101). SN 85-259,996. PUB. 1-10-2012. FILED 3-7-2011.
- 4,117,297. ADVANCED UROLOGY SPECIALISTS AND DESIGN. CENTRAL FLORIDA UROLOGY SPECIALISTS, LLC, (U.S. CLS. 100 AND 101). SN 85-260,070. PUB. 1-10-2012. FILED 3-7-2011.
- 4,117,298. EVERYDAY IS BREAST CANCER AWARENESS DAY AT FAIRFAX RADIOLOGY (STANDARD CHARACTER). FAIRFAX RADIOLOGICAL CONSULTANTS, P.C., (U.S. CLS. 100 AND 101). SN 85-260,164. PUB. 1-10-2012. FILED 3-7-2011.
- 4,117,316 (*See Class 42 for this trademark*).
- 4,117,317. RIDGE DIAGNOSTICS (STANDARD CHARACTER). RIDGE DIAGNOSTICS, INC., (U.S. CLS. 100 AND 101). SN 85-264,659. PUB. 1-10-2012. FILED 3-11-2011.
- 4,117,318. RIDGE DIAGNOSTICS AND DESIGN. RIDGE DIAGNOSTICS, INC., (U.S. CLS. 100 AND 101). SN 85-264,705. PUB. 1-10-2012. FILED 3-11-2011.
- 4,117,336. PREGNANTHELP AND DESIGN. CARENET PREGNANCY SERVICES OF DUPAGE COUNTY, INC., (U.S. CLS. 100 AND 101). SN 85-268,546. PUB. 1-10-2012. FILED 3-16-2011.
- 4,117,348. VIRTUA AND DESIGN. VIRTUA HEALTH, INC., (U.S. CLS. 100 AND 101). SN 85-270,620. PUB. 1-10-2012. FILED 3-18-2011.
- 4,117,384 (*See Class 35 for this trademark*).
- 4,117,405 (*See Class 41 for this trademark*).
- 4,117,414. SHAHRAM SALEMY, MD (STANDARD CHARACTER). SHAHRAM SALEMY, M.D., PLLC, (U.S. CLS. 100 AND 101). SN 85-285,905. PUB. 1-10-2012. FILED 4-4-2011.
- 4,117,528. MASSAGE ADVANTAGE AND DESIGN. MASSAGE ADVANTAGE, INC., (U.S. CLS. 100 AND 101). SN 85-308,092. PUB. 10-4-2011. FILED 4-29-2011.
- 4,117,573. W THE WAX SPECIALISTS (STYLIZED). WAX SPECIALISTS, LLC, (U.S. CLS. 100 AND 101). SN 85-319,994. PUB. 1-10-2012. FILED 5-13-2011.
- 4,117,581. RENEW YOU (STANDARD CHARACTER). MENORAH MANOR, INC., (U.S. CLS. 100 AND 101). SN 85-321,440. PUB. 1-10-2012. FILED 5-16-2011.
- 4,117,588. SLENDER FIT U (STANDARD CHARACTER). SLENDER FIT U, LLC, (U.S. CLS. 100 AND 101). SN 85-322,905. PUB. 1-10-2012. FILED 5-17-2011.
- 4,117,589. SLENDER FIT U "GET SLIM, SKIP THE GYM" AND DESIGN. SLENDER FIT U, LLC, (U.S. CLS. 100 AND 101). SN 85-322,965. PUB. 1-10-2012. FILED 5-17-2011.
- 4,117,591. PARKER RANCH (STANDARD CHARACTER). PARKER RANCH, INC., (U.S. CLS. 100 AND 101). SN 85-323,336. PUB. 1-10-2012. FILED 5-17-2011.
- 4,117,620. EMURGENTCARE (STANDARD CHARACTER). EMURGENTCARE, PLLC, (U.S. CLS. 100 AND 101). SN 85-327,355. PUB. 1-10-2012. FILED 5-23-2011.
- 4,117,648. WWW. MOHSPROS.COM MOHS PROS YOUR SKIN CANCER. OUR EXPERTISE. AND DESIGN. CRUZ, ANTONIO PAULINO, (U.S. CLS. 100 AND 101). SN 85-333,473. PUB. 1-10-2012. FILED 5-30-2011.
- 4,117,662 (*See Class 35 for this trademark*).
- 4,117,663 (*See Class 35 for this trademark*).
- 4,117,722. COLON ROLLIN' (STANDARD CHARACTER). MARY E. B. DAVIS, DBA COLON ROLLIN', (U.S. CLS. 100 AND 101). SN 85-347,964. PUB. 1-10-2012. FILED 6-16-2011.
- 4,117,758. REISS PROFILE (STANDARD CHARACTER). IDS PUBLISHING CORPORATION, (U.S. CLS. 100 AND 101). SN 85-352,509. PUB. 1-10-2012. FILED 6-22-2011.
- 4,117,790. HOLISTICALLY FIT AND DESIGN. MCBRIDE, LAUREN D, DBA HOLISTICALLY FIT, (U.S. CLS. 100 AND 101). SN 85-356,522. PUB. 1-10-2012. FILED 6-27-2011.
- 4,117,794. MIDNIGHT RXPRESS (STANDARD CHARACTER). PROPHARMCARE, INC, (U.S. CLS. 100 AND 101). SN 85-357,634. PUB. 1-10-2012. FILED 6-28-2011.
- 4,117,854. CITYMD (STANDARD CHARACTER). CITY MEDICAL OF UPPER EAST SIDE, PLLC, (U.S. CLS. 100 AND 101). SN 85-364,744. PUB. 1-10-2012. FILED 7-6-2011.
- 4,117,944. MISCELLANEOUS DESIGN. SAINT MARY'S HOME OF ERIE, (U.S. CLS. 100 AND 101). SN 85-369,374. PUB. 1-10-2012. FILED 7-12-2011.
- 4,117,959 (*See Class 37 for this trademark*).
- 4,117,989. SAGE FAMILY FARMS NON SIBI AND DESIGN. SAGE, DUSTIN, (U.S. CLS. 100 AND 101). SN 85-371,266. PUB. 1-10-2012. FILED 7-14-2011.
- 4,118,004. OPTIMA DIAGNOSTIC IMAGING (STANDARD CHARACTER). BEVERLY HILLS ONCOLOGY MEDICAL GROUP, INC., (U.S. CLS. 100 AND 101). SN 85-371,905. PUB. 1-10-2012. FILED 7-14-2011.
- 4,118,014. RELAXING NOTE THERAPEUTIC MASSAGE AND DESIGN. RELAXING NOTE LLC, (U.S. CLS. 100 AND 101). SN 85-372,201. PUB. 1-10-2012. FILED 7-15-2011.
- 4,118,015. DENTAL HEALTH REWARDS (STANDARD CHARACTER). TIMOTHY C VERHAREN, DDS, PLLC, (U.S. CLS. 100 AND 101). SN 85-372,247. PUB. 1-10-2012. FILED 7-15-2011.
- 4,118,034. MIDDLE PATH MEDICINE (STANDARD CHARACTER). MIDDLE PATH MEDICINE, (U.S. CLS. 100 AND 101). SN 85-372,936. PUB. 1-10-2012. FILED 7-15-2011.
- 4,118,164. SHANTY CREEK RESORTS (STANDARD CHARACTER). RESORT PROPERTY HOLDING, LLC, (U.S. CLS. 100 AND 101). SN 85-375,509. PUB. 1-10-2012. FILED 7-19-2011.
- 4,118,165 (*See Class 41 for this trademark*).
- 4,118,179 (*See Class 5 for this trademark*).
- 4,118,196. MOBILEXUSA (STANDARD CHARACTER). MX USA, INC., (U.S. CLS. 100 AND 101). SN 85-376,565. PUB. 1-10-2012. FILED 7-20-2011.
- 4,118,267. PHYSICIANS LIFECENTERS HEALTH & WELLNESS AND DESIGN. PHYSICIANS LIFE CENTERS LLC, (U.S. CLS. 100 AND 101). SN 85-379,774. PUB. 1-10-2012. FILED 7-25-2011.
- 4,118,279. OPERATION RAINBOW (STANDARD CHARACTER). OPERATION RAINBOW, INC., (U.S. CLS. 100 AND 101). SN 85-380,275. PUB. 1-10-2012. FILED 7-25-2011.
- 4,118,303. YOU ANEW (STANDARD CHARACTER). LEHIGH VALLEY CHIROPRACTIC, PC, (U.S. CLS. 100 AND 101). SN 85-383,057. PUB. 1-10-2012. FILED 7-28-2011.
- 4,118,304. SMILES BY SANDS (STANDARD CHARACTER). JASON SANDS, (U.S. CLS. 100 AND 101). SN 85-383,303. PUB. 1-10-2012. FILED 7-28-2011.
- 4,118,344 (*See Class 35 for this trademark*).
- 4,118,358. NINE ZERO ONE (STANDARD CHARACTER). CAPRILEE, LLC, (U.S. CLS. 100 AND 101). SN 85-390,053. PUB. 1-10-2012. FILED 8-4-2011.
- 4,118,363. EARLY DETECTION IS THE KEY TO LONGEVITY (STANDARD CHARACTER). CLARISSE CLEMONS-FERRARA, MD, (U.S. CLS. 100 AND 101). SN 85-390,264. PUB. 1-10-2012. FILED 8-5-2011.
- 4,118,377. GET SUGARED (STANDARD CHARACTER). SKIN SO SWEET, INC., (U.S. CLS. 100 AND 101). SN 85-390,995. PUB. 1-10-2012. FILED 8-5-2011.
- 4,118,378. S WELCOME TO SKIN SO SWEET "GET SUGARED" AND DESIGN. SKIN SO SWEET, INC., (U.S. CLS. 100 AND 101). SN 85-391,004. PUB. 1-10-2012. FILED 8-5-2011.
- 4,118,430. . . . BECAUSE LIVING WITH PAIN ISN'T REALLY LIVING! (STANDARD CHARACTER). ZEHR, ROBERT J., (U.S. CLS. 100 AND 101). SN 85-392,923. PUB. 1-10-2012. FILED 8-9-2011.
- 4,118,450. AN EXTRAORDINARY PLACE FOR YOUR EXTRAORDINARY CHILD (STANDARD CHARACTER). THE SUPER DENTISTS, INC., (U.S. CLS. 100 AND 101). SN 85-393,241. PUB. 1-10-2012. FILED 8-9-2011.
- 4,118,454. THE PRETTY KITTY (STANDARD CHARACTER). THE PRETTY KITTY, INC., (U.S. CLS. 100 AND 101). SN 85-393,304. PUB. 1-10-2012. FILED 8-9-2011.
- 4,118,477 (*See Class 41 for this trademark*).
- 4,118,554. MISCELLANEOUS DESIGN. PATRICK D. BRIESE, DDS, LLC, (U.S. CLS. 100 AND 101). SN 85-395,318. PUB. 1-10-2012. FILED 8-11-2011.
- 4,118,670 (*See Class 35 for this trademark*).

4,118,671 (*See Class 35 for this trademark.*)
 4,118,676 (*See Class 35 for this trademark.*)
 4,118,684. **WHEN YOUR CHILD NEEDS A HOSPITAL, EVERYTHING MATTERS (STANDARD CHARACTER).** NATIONWIDE CHILDREN'S HOSPITAL, (U.S. CLS. 100 AND 101). SN 85-407,532. PUB. 1-10-2012. FILED 8-25-2011.
 4,118,688. **BREASTADVANTAGE AND DESIGN.** CENTER FOR DIAGNOSTIC IMAGING, INC., (U.S. CLS. 100 AND 101). SN 85-410,926. PUB. 1-10-2012. FILED 8-30-2011.
 4,118,708. **MISCELLANEOUS DESIGN.** NATIONWIDE CHILDREN'S HOSPITAL, (U.S. CLS. 100 AND 101). SN 85-428,995. PUB. 1-10-2012. FILED 9-22-2011.

CLASS 45—PERSONAL AND LEGAL SERVICES

4,116,705 (*See Class 35 for this trademark.*)
 4,116,710 (*See Class 16 for this trademark.*)
 4,116,764 (*See Class 9 for this trademark.*)
 4,116,867. **MONKEYPLATE (STANDARD CHARACTER).** MONKEYPLATES LIMITED, (U.S. CLS. 100 AND 101). SN 79-104,176. PUB. 1-10-2012. FILED 8-12-2011.
 4,116,878 (*See Class 35 for this trademark.*)
 4,116,895 (*See Class 9 for this trademark.*)
 4,116,930. **BEZPLATNY NUMER PO BEZPLATNA PORADE (STANDARD CHARACTER).** BELCHER, MATTHEW J. AND BELCHER LAW OFFICE, (U.S. CLS. 100 AND 101). SN 85-107,227. PUB. 1-10-2012. FILED 8-13-2010.
 4,116,937 (*See Class 9 for this trademark.*)
 4,116,954 (*See Class 35 for this trademark.*)
 4,116,978 (*See Class 35 for this trademark.*)
 4,116,982 (*See Class 36 for this trademark.*)
 4,116,994 (*See Class 41 for this trademark.*)
 4,117,061 (*See Class 43 for this trademark.*)
 4,117,082 (*See Class 35 for this trademark.*)
 4,117,090 (*See Class 9 for this trademark.*)
 4,117,093 (*See Class 25 for this trademark.*)
 4,117,095. **MISCELLANEOUS DESIGN.** ATTORNEY'S LEGAL SUPPORT SERVICES, INC., (U.S. CLS. 100 AND 101). SN 85-225,612. PUB. 1-10-2012. FILED 1-25-2011.
 4,117,124 (*See Class 35 for this trademark.*)
 4,117,167. **K KELLTECH SYSTEMS AND DESIGN.** KELLAN, INC. DBA KELLTECH SYSTEMS, (U.S. CLS. 100 AND 101). SN 85-235,814. PUB. 1-10-2012. FILED 2-7-2011.
 4,117,229 (*See Class 41 for this trademark.*)
 4,117,258. **LET US FIND YOUR ASSETS BEFORE THEY'RE GONE (STANDARD CHARACTER).** ARIXMAR, LLC, (U.S. CLS. 100 AND 101). SN 85-251,181. PUB. 1-10-2012. FILED 2-24-2011.
 4,117,266 (*See Class 35 for this trademark.*)
 4,117,285 (*See Class 41 for this trademark.*)
 4,117,324 (*See Class 38 for this trademark.*)
 4,117,354 (*See Class 35 for this trademark.*)
 4,117,359. **JOYVILLE (STANDARD CHARACTER).** MUSE CONSULTING GROUP, LLC, (U.S. CLS. 100 AND 101). SN 85-273,649. PUB. 1-10-2012. FILED 3-22-2011.
 4,117,377. **MODERN FAMILY SURROGACY CENTER AND DESIGN.** MODERN FAMILY SURROGACY CENTER, INC, (U.S. CLS. 100 AND 101). SN 85-279,150. PUB. 1-10-2012. FILED 3-28-2011.
 4,117,384 (*See Class 35 for this trademark.*)
 4,117,427. **PUP SQUAD ANIMAL RESCUE AND DESIGN.** PUP SQUAD ANIMAL RESCUE, (U.S. CLS. 100 AND 101). SN 85-288,927. PUB. 1-10-2012. FILED 4-7-2011.
 4,117,432. **FIRSTLINE | INSIDE COUNSEL (STANDARD CHARACTER).** PANCHAL ASSOCIATES LLP, (U.S. CLS. 100 AND 101). SN 85-290,365. PUB. 1-10-2012. FILED 4-8-2011.
 4,117,526. **MISCELLANEOUS DESIGN.** AKIN GUMP STRAUSS HAUER & FELD LLP, (U.S. CLS. 100 AND 101). SN 85-307,323. PUB. 1-10-2012. FILED 4-28-2011.
 4,117,544 (*See Class 42 for this trademark.*)
 4,117,586 (*See Class 16 for this trademark.*)
 4,117,606 (*See Class 36 for this trademark.*)
 4,117,614. **METYET (STANDARD CHARACTER).** 7847335 CANADA INC., (U.S. CLS. 100 AND 101). SN 85-325,586. PUB. 1-10-2012. FILED 5-20-2011.
 4,117,730. **SHEPHERD'S HEART (STANDARD CHARACTER).** DILL, JAMES, (U.S. CLS. 100 AND 101). SN 85-349,234. PUB. 1-10-2012. FILED 6-17-2011.
 4,117,766 (*See Class 35 for this trademark.*)
 4,117,768. **SAFER CITIES-BETTER CITIES (STANDARD CHARACTER).** SPECTRUM TRACKING SYSTEMS, INC., (U.S. CLS. 100 AND 101). SN 85-353,827. PUB. 1-10-2012. FILED 6-23-2011.
 4,117,770. **GEOFFREY FIEGER AMERICA'S TRIAL LAWYER (STANDARD CHARACTER).** FIEGER, FIEGER, KENNEY, JOHNSON & GIROUX, P.C., (U.S. CLS. 100 AND 101). SN 85-354,140. PUB. 1-10-2012. FILED 6-23-2011.
 4,117,779. **PIMPIN POOCHES (STANDARD CHARACTER).** STAMBUL, DEREK C, (U.S. CLS. 100 AND 101). SN 85-355,680. PUB. 1-10-2012. FILED 6-24-2011.
 4,117,786. **MELISBEK (STANDARD CHARACTER).** MELISBEK, ULAN, (U.S. CLS. 100 AND 101). SN 85-356,375. PUB. 1-10-2012. FILED 6-26-2011.
 4,117,799 (*See Class 14 for this trademark.*)
 4,117,802 (*See Class 41 for this trademark.*)
 4,117,804 (*See Class 1 for this trademark.*)
 4,117,806 (*See Class 1 for this trademark.*)
 4,117,807 (*See Class 1 for this trademark.*)
 4,117,849 (*See Class 35 for this trademark.*)
 4,117,870. **TOPHAT INTELLECTUAL PROPERTY CONSULTANTS AND DESIGN.** BASISTA, JOSEPH J., DBA TOPHAT INTELLECTUAL PROPERTY CONSULTANTS, (U.S. CLS. 100 AND 101). SN 85-365,588. PUB. 1-10-2012. FILED 7-7-2011.
 4,117,955. **THE KRINGLE JINGLE (STANDARD CHARACTER).** DAVID V. GLORIOUS, (U.S. CLS. 100 AND 101). SN 85-370,172. PUB. 1-10-2012. FILED S.R. 7-13-2011; AM. P.R. 11-7-2011.
 4,117,962. **I LIFE AND DESIGN.** CENTRAL CHRISTIAN CHURCH, (U.S. CLS. 100 AND 101). SN 85-370,417. PUB. 1-10-2012. FILED 7-13-2011.
 4,117,973 (*See Class 41 for this trademark.*)
 4,117,975 (*See Class 41 for this trademark.*)
 4,117,985. **CRAFT INTERNATIONAL AND DESIGN.** CRAFT INTERNATIONAL, LLC, (U.S. CLS. 100 AND 101). SN 85-371,153. PUB. 1-10-2012. FILED 7-14-2011.
 4,118,033. **MWR LEGAL (STANDARD CHARACTER).** MOSTER, WYNNE & RESSLER, P.C., (U.S. CLS. 100 AND 101). SN 85-372,903. PUB. 1-10-2012. FILED 7-15-2011.
 4,118,100. **ONE WORLD RITUALS AND DESIGN.** GRAN-NAN, ELIZABETH, (U.S. CLS. 100 AND 101). SN 85-374,340. PUB. 1-10-2012. FILED 7-18-2011.
 4,118,117 (*See Class 38 for this trademark.*)
 4,118,131 (*See Class 41 for this trademark.*)
 4,118,145. **I STARTED A CHURCH (STANDARD CHARACTER).** GLOBAL ACTION, (U.S. CLS. 100 AND 101). SN 85-375,319. PUB. 1-10-2012. FILED 7-19-2011.
 4,118,180. **WIT MINISTRIES (STANDARD CHARACTER).** CLUBB, MICHAEL, (U.S. CLS. 100 AND 101). SN 85-375,919. PUB. 1-10-2012. FILED 7-20-2011.
 4,118,194. **BUSH INTELLECTUAL PROPERTY LAW (STANDARD CHARACTER).** BUSH INTELLECTUAL PROPERTY LAW GROUP, LLC, (U.S. CLS. 100 AND 101). SN 85-376,519. PUB. 1-10-2012. FILED 7-20-2011.
 4,118,215 (*See Class 36 for this trademark.*)
 4,118,217 (*See Class 36 for this trademark.*)
 4,118,239. **1-800LOCKOUT (STYLIZED).** CRUM, MICHAEL, DBA A ALL AROUND LOCKSMITHS, (U.S. CLS. 100 AND 101). SN 85-378,076. PUB. 1-10-2012. FILED 7-22-2011.
 4,118,317. **TIEXCHANGE (STANDARD CHARACTER).** BROOKE J. SAUCIER, (U.S. CLS. 100 AND 101). SN 85-386,993. PUB. 1-10-2012. FILED 8-2-2011.
 4,118,365. **IMAGECOLLECT (STANDARD CHARACTER).** AUDIOMICRO, INC., (U.S. CLS. 100 AND 101). SN 85-390,402. PUB. 1-10-2012. FILED 8-5-2011.
 4,118,367 (*See Class 40 for this trademark.*)
 4,118,400. **FRIENDPROJECT (STANDARD CHARACTER).** CLEARVISTA, LLC, (U.S. CLS. 100 AND 101). SN 85-392,220. PUB. 1-10-2012. FILED 8-8-2011.
 4,118,506. **MISCELLANEOUS DESIGN.** FLORIDA VANGUARD ATTORNEYS, LLC, (U.S. CLS. 100 AND 101). SN 85-394,330. PUB. 1-10-2012. FILED 8-10-2011.

4,118,521 (*See Class 35 for this trademark*).

4,118,544 (*See Class 35 for this trademark*).

4,118,553. **HIGHER PERFORMANCE RISE ABOVE MY (STYLIZED)**. MURRAY & YOUNG, (U.S. CLS. 100 AND 101). SN 85-395,317. PUB. 1-10-2012. FILED 8-11-2011.

4,118,603. **COMMUNR (STANDARD CHARACTER)**. COLLECTIVE CORE, (U.S. CLS. 100 AND 101). SN 85-396,234. PUB. 1-10-2012. FILED 8-12-2011.

4,118,681. **ETS BUSINESS LAW ENFORCEMENT AND DESIGN**. SPECTRUM TRACKING SYSTEMS, INC., (U.S. CLS. 100 AND 101). SN 85-405,628. PUB. 1-10-2012. FILED 8-24-2011.

4,118,720. **420DUDE (STANDARD CHARACTER)**. BALAGIA, JAMIE, (U.S. CLS. 100 AND 101). SN 85-440,776. PUB. 1-10-2012. FILED 10-6-2011.

4,118,748. **LOCALSIN (STANDARD CHARACTER)**. PINPOINTS X LTD., (U.S. CLS. 100 AND 101). SN 85-976,267. PUB. 12-6-2011. FILED 7-7-2011.

* * * * *

SECTION 2.—PRIOR UNITED STATES CLASSIFICATION

COLLECTIVE MEMBERSHIP MARKS

CLASS 200—COLLECTIVE MEMBERSHIP

4,117,094. **MASSACHUSETTS STATE COLLEGIATE ATHLETIC CONFERENCE MASCAC AND DESIGN.** MASSACHUSETTS STATE COLLEGIATE ATHLETIC CONFERENCE, SN 85-225,528. PUB. 1-10-2012. FILED 1-25-2011.

4,117,379. **MISCELLANEOUS DESIGN.** NATIONAL MODEL RAILROAD ASSOCIATION, INC., SN 85-279,284. PUB. 1-10-2012. FILED 3-29-2011.

CERTIFICATION MARKS

CLASS A—GOODS

4,116,595. **IRSIMPLE (STANDARD CHARACTER).** INFRARED DATA ASSOCIATION, INC., SN 77-309,995. PUB. 1-10-2012. FILED 10-22-2007.

CLASS B—SERVICES

4,116,635. **BQ-9000 (STANDARD CHARACTER).** NATIONAL BIODIESEL BOARD, SN 77-839,542. PUB. 1-10-2012. FILED 10-1-2009.

* * * * *

TRADEMARK REGISTRATIONS ISSUED UNDER SECTION 1(d)

The following marks have registered on the Principal Register pursuant to the intent-to-use provisions of Section 1(d) of the Trademark Act of 1946, as amended.

SECTION 1.— INTERNATIONAL CLASSIFICATION

The short titles associated below with the international class numbers are terms designed merely for quick identification and are not an official part of the international classification. The full names of international classes are given in section 6.1 of the trademark rules of practice.

The designation "U.S. Cl." appearing in this section refers to the U.S. class in effect prior to Sep. 1, 1973 rather than the international class which applies to applications filed on or after that date. For adoption of international classification see notice in the OFFICIAL GAZETTE of Jun. 26, 1973 (911 O.G. TM 210).

Application in more than one class

4,118,752. CANCERLINK ONTARIO INC., TORONTO, ONTARIO M3B 1Y8, CANADA. SN 76-677,360. PUB. 11-2-2010, FILED 5-24-2007.



PRIORITY CLAIMED UNDER SEC. 44(D) ON CANADA APPLICATION NO. 1343561, FILED 4-16-2007, REG. NO. TMA766211, DATED 5-10-2010, EXPIRES 5-10-2025.

NO CLAIM IS MADE TO THE EXCLUSIVE RIGHT TO USE "ONCOLOGYEDUCATION.CA", APART FROM THE MARK AS SHOWN.

CLASS 16—PAPER GOODS AND PRINTED MATTER

FOR (BASED ON 44(E)) PRINTED EDUCATIONAL MATERIALS, NAMELY, NEWSLETTERS IN THE FIELD OF THE TREATMENT AND PREVENTION OF CANCER (U.S. CLS. 2, 5, 22, 23, 29, 37, 38 AND 50).

CLASS 41—EDUCATION AND ENTERTAINMENT

FOR (BASED ON USE) (BASED ON 44(E)) EDUCATIONAL SERVICES, NAMELY, PROVIDING CLASSES, SEMINARS AND WORKSHOPS IN THE FIELD OF THE PREVENTION AND TREATMENT OF CANCER; PROVIDING ON-LINE PUBLICATIONS IN THE NATURE OF ARTICLES, NEWSLETTERS AND GUIDELINES IN THE FIELD OF PREVENTION AND TREATMENT OF CANCER (U.S. CLS. 100, 101 AND 107).

FIRST USE 1-0-2009; IN COMMERCE 1-0-2009.

CLASS 44—MEDICAL, BEAUTY AND AGRICULTURAL SERVICES

FOR (BASED ON USE) (BASED ON 44(E)) OPERATING A WEBSITE PROVIDING ARTICLES, NEWSLETTERS, GUIDELINES AND INFORMATION IN THE AREA OF THE PREVENTION AND TREATMENT OF CANCER (U.S. CLS. 100 AND 101).

FIRST USE 5-0-2007; IN COMMERCE 5-0-2007.

4,118,758. TECH-MED SERVICES, INC., SMITHTOWN, NY. SN 76-700,695. PUB. 6-7-2011, FILED 12-3-2009.



NO CLAIM IS MADE TO THE EXCLUSIVE RIGHT TO USE "SERVICES" AND THE CADUCEUS SYMBOL, APART FROM THE MARK AS SHOWN.

CLASS 9—ELECTRICAL AND SCIENTIFIC APPARATUS

FOR DIGITAL TIMERS AND LINEN TAPE MEASURES (U.S. CLS. 21, 23, 26, 36 AND 38).

FIRST USE 2-10-2000; IN COMMERCE 2-10-2000.

CLASS 10—MEDICAL APPARATUS

FOR MEDICAL DIAGNOSTIC EQUIPMENT, NAMELY, STETHOSCOPES, SPHYGMOMANOMETERS AND EYE CHARTS; AND SUNDRY MEDICAL ITEMS, NAMELY, ALCOHOL DISPENSERS; FRACTURE KITS, COMPRISED OF WEATHERPROOF NYLON CARRY BAG, ONE ADULT ARM SPLINT, ONE ADULT LEG SPLINT, ONE CHILD ARM SPLINT, ONE CHILD LEG SPLINT AND ONE ARM/SHOULDER IMMOBILIZER; LINEN TAPE MEASURES USED FOR BODY MEASUREMENT, WOUND MEASUREMENT AND WATER RETENTION MEASUREMENT; EYE TEST CABINETS, COMPRISED OF METAL CABINET WITH BAKED ENAMEL FINISH, CARRY HANDLE AND POWER CORD (U.S. CLS. 26, 39 AND 44).

FIRST USE 2-10-2000; IN COMMERCE 2-10-2000.

CLASS 16—PAPER GOODS AND PRINTED MATTER

FOR ENVELOPES (U.S. CLS. 2, 5, 22, 23, 29, 37, 38 AND 50).

FIRST USE 2-10-2000; IN COMMERCE 2-10-2000.

CLASS 20—FURNITURE AND ARTICLES NOT OTHERWISE CLASSIFIED

FOR COMMERCIAL DISPENSERS FOR PILLS SOLD EMPTY (U.S. CLS. 2, 13, 22, 25, 32 AND 50).

FIRST USE 2-10-2000; IN COMMERCE 2-10-2000.

CLASS 21—HOUSEWARES AND GLASS

FOR PERSONAL DISPENSERS FOR PILLS FOR DOMESTIC USE; GLASS SUNDRY JARS FOR STORING MEDICAL SUPPLIES; PLASTIC SUNDRY JARS FOR STORING MEDICAL SUPPLIES (U.S. CLS. 2, 13, 23, 29, 30, 33, 40 AND 50).

FIRST USE 2-10-2000; IN COMMERCE 2-10-2000.

4,118,767. RICOH COMPANY, LTD., OHTA-KU, TOKYO, JAPAN. SN 76-704,769. PUB. 6-14-2011, FILED 10-4-2010.

**Managed
Document
Services**
MPS and Beyond

4,118,759. TECH-MED SERVICES INC., SMITHTOWN, NY. SN 76-700,696. PUB. 6-14-2011, FILED 12-3-2009.

TECH-MED SERVICES

THE MARK CONSISTS OF STANDARD CHARACTERS WITHOUT CLAIM TO ANY PARTICULAR FONT, STYLE, SIZE, OR COLOR.

NO CLAIM IS MADE TO THE EXCLUSIVE RIGHT TO USE "SERVICES", APART FROM THE MARK AS SHOWN.

CLASS 9—ELECTRICAL AND SCIENTIFIC APPARATUS

FOR DIGITAL TIMERS AND LINEN TAPE MEASURES (U.S. CLS. 21, 23, 26, 36 AND 38).

FIRST USE 2-10-2000; IN COMMERCE 2-10-2000.

CLASS 10—MEDICAL APPARATUS

FOR MEDICAL DIAGNOSTIC EQUIPMENT, NAMELY, STETHOSCOPES, SPHYGMOMANOMETERS AND EYE CHARTS; AND SUNDRY MEDICAL ITEMS, NAMELY, ALCOHOL DISPENSERS; FRACTURE KITS, COMPRISED OF WEATHERPROOF NYLON CARRY BAG, ONE ADULT ARM SPLINT, ONE ADULT LEG SPLINT, ONE CHILD ARM SPLINT, ONE CHILD LEG SPLINT AND ONE ARM/SHOULDER IMMOBILIZER; LINEN TAPE MEASURES USED FOR BODY MEASUREMENT, WOUND MEASUREMENT AND WATER RETENTION MEASUREMENT; EYE TEST CABINETS, COMPRISED OF METAL CABINET WITH BAKED ENAMEL FINISH, CARRY HANDLE AND POWER CORD (U.S. CLS. 26, 39 AND 44).

FIRST USE 2-10-2000; IN COMMERCE 2-10-2000.

CLASS 16—PAPER GOODS AND PRINTED MATTER

FOR ENVELOPES (U.S. CLS. 2, 5, 22, 23, 29, 37, 38 AND 50).

FIRST USE 2-10-2000; IN COMMERCE 2-10-2000.

CLASS 20—FURNITURE AND ARTICLES NOT OTHERWISE CLASSIFIED

FOR COMMERCIAL DISPENSERS FOR PILLS SOLD EMPTY (U.S. CLS. 2, 13, 22, 25, 32 AND 50).

FIRST USE 2-10-2000; IN COMMERCE 2-10-2000.

CLASS 21—HOUSEWARES AND GLASS

FOR PERSONAL DISPENSERS FOR PILLS FOR DOMESTIC USE; GLASS SUNDRY JARS FOR STORING MEDICAL SUPPLIES; PLASTIC SUNDRY JARS FOR STORING MEDICAL SUPPLIES (U.S. CLS. 2, 13, 23, 29, 30, 33, 40 AND 50).

FIRST USE 2-10-2000; IN COMMERCE 2-10-2000.

OWNER OF U.S. REG. NO. 2,956,133.

NO CLAIM IS MADE TO THE EXCLUSIVE RIGHT TO USE "MANAGED DOCUMENT SERVICES MPS", APART FROM THE MARK AS SHOWN.

THE MARK CONSISTS OF THE WORDING "MANAGED DOCUMENT SERVICES MPS AND BEYOND" IN STYLIZED FONT.

CLASS 35—ADVERTISING AND BUSINESS

FOR CONSUMER PRODUCT INFORMATION CONSULTATION SERVICES IN THE FIELD OF DOCUMENT REPRODUCTION EQUIPMENT AND PROCESSES; DOCUMENT REPRODUCTION AND DOCUMENT INDEXING FOR OTHERS; CONSULTATION SERVICES IN CONNECTION WITH FLEET MANAGEMENT OF PRINTERS, MULTI-FUNCTIONAL PRODUCTS, NETWORK DEVICES, AND DOCUMENT MANAGEMENT SYSTEMS; OUTSOURCING SERVICES IN THE FIELD OF ON-SITE AND OFF-SITE DOCUMENT MANAGEMENT; MARKET ASSESSMENT AND BUSINESS ADVISORY SERVICES FOR IMPROVING WORKFLOW, PRODUCTIVITY, CAPABILITY AND PROFITABILITY IN THE FIELD OF DOCUMENT REPRODUCTION SERVICES (U.S. CLS. 100, 101 AND 102).

FIRST USE 1-1-2010; IN COMMERCE 1-1-2010.

CLASS 42—SCIENTIFIC AND COMPUTER SERVICES

FOR TECHNOLOGICAL CONSULTATION SERVICES IN THE FIELD OF DOCUMENT REPRODUCTION EQUIPMENT AND PROCESSES; NEW PRODUCT DESIGN SERVICES FOR IMPROVING WORKFLOW, PRODUCTIVITY, CAPABILITY AND PROFITABILITY IN THE FIELD OF DOCUMENT REPRODUCTION SERVICES; TECHNICAL SUPPORT SERVICES IN THE FIELD OF DOCUMENT-RELATED TECHNOLOGY AND PROCESSES, NAMELY, TROUBLESHOOTING IN THE NATURE OF DIAGNOSIS OF PROBLEMS WITH OFFICE EQUIPMENT, SUCH AS, COPIERS AND FACSIMILE MACHINES; SOFTWARE INTEGRATION (U.S. CLS. 100 AND 101).

FIRST USE 1-1-2010; IN COMMERCE 1-1-2010.

4,118,773. INFRASTRUCTURE CORPORATION OF AMERICA, INC., BRENTWOOD, TN. SN 76-706,818. PUB. 8-2-2011, FILED 3-15-2011.

BRIDGEWEB

THE MARK CONSISTS OF A DESIGN OF A BRIDGE OVER THE WORDING "BRIDGEWEB".

CLASS 9—ELECTRICAL AND SCIENTIFIC APPARATUS

FOR DOWNLOADABLE INTERACTIVE SOFTWARE FOR THE COLLECTION OF NUMERICAL, TEXT, PHOTO, AUDIO, VIDEO, PLAN, TABLE AND SKETCH DATA RELATING TO THE FIELD OF BRIDGE MAINTENANCE AND REPAIR (U.S. CLS. 21, 23, 26, 36 AND 38).

FIRST USE 2-0-2008; IN COMMERCE 2-0-2008.

CLASS 37—CONSTRUCTION AND REPAIR

FOR BRIDGE MAINTENANCE AND REPAIR (U.S. CLS. 100, 103 AND 106).

FIRST USE 2-0-2008; IN COMMERCE 2-0-2008.

CLASS 42—SCIENTIFIC AND COMPUTER SERVICES

FOR PROVIDING ON-LINE NON-DOWNLOADABLE SOFTWARE IN THE FIELD OF BRIDGE INSPECTION MANAGEMENT SYSTEMS THAT SCHEDULES ALL INSPECTION ACTIVITIES, PROVIDES QUALITY CONTROL REVIEWS AND SCORINGS, PROVIDES INSPECTION AND OPERATIONAL ANALYSIS AND REPORTS, PROVIDES TEAM COMMUNICATIONS TOOLS, PROCESS TRACKING AND MONITORS FUTURE STRUCTURES; PROVIDING ON-LINE NON-DOWNLOADABLE SOFTWARE IN THE FIELD OF A BRIDGE MANAGEMENT SYSTEM FOR BRIDGE INSPECTION, ANALYSIS, MAINTENANCE, REPAIR, REHAB AND REPLACEMENT WORK, WHICH PROVIDES A DATABASE FOR USER INPUT AND USER UPLOAD AND SYNC OF NUMERICAL, TEXT, PHOTO, AUDIO, VIDEO, TABLE, PLAN, AND SKETCH DATA AND WHICH DATABASE PROVIDES A COLLECTION OF INTERACTIVE INFORMATION FOR ANALYSIS AND REPORTING REGARDING INSPECTION INFORMATION, DEFICIENCY INFORMATION, INVENTORY INFORMATION, PLANS INFORMATION, CUSTOMER CALLS INFORMATION, COST BENEFIT INFORMATION, VALUATION INFORMATION, PRIORITIZATION INFORMATION, AND ALSO PROVIDES A WORK ORDER SYSTEM ANALYSIS THAT GENERATES WORK REQUESTS, TIMED ACTIVITIES, CUSTOMIZABLE WORK ACTIVITIES, QUALITY REVIEWS, COST REVIEWS, COST DEVELOPMENTS, COST ASSIGNMENTS (U.S. CLS. 100 AND 101).

FIRST USE 2-0-2008; IN COMMERCE 2-0-2008.

4,118,776. SOMERS-HILL, SHARON MAY, NEWPORT BEACH, CA. SN 77-050,561. PUB. 1-22-2008, FILED 11-25-2006.

NobleFibers

THE MARK CONSISTS OF STANDARD CHARACTERS WITHOUT CLAIM TO ANY PARTICULAR FONT, STYLE, SIZE, OR COLOR.

CLASS 24—FABRICS

FOR BOUTIQUE GOODS FOR THE HOME, NAMELY, BED BLANKETS, THROWS, PILLOW SLIPS AND BED SHEETS, ALL MADE PRIMARILY FROM COTTON, SILK, MATERIAL HARVESTED FROM ALPACA, VICUNYA, RABBIT, ANGORA, POSSUM, GOAT, MOHAIR, CASHGORA, CASHMERE AND SHEEP, AND BLENDS OF COMPRISED THEREOF (U.S. CLS. 42 AND 50).

FIRST USE 12-31-2007; IN COMMERCE 12-31-2007.

CLASS 25—CLOTHING

FOR BOUTIQUE CASUAL CLOTHING, NAMELY, SWEATERS, COATS, VESTS, GLOVES, MITTENS, SCARVES AND SOCKS, AND HEADWEAR, ALL MADE PRIMARILY FROM COTTON, SILK, MATERIAL HARVESTED FROM ALPACA, VICUNYA, RABBIT, ANGORA, POSSUM, GOAT, MOHAIR, CASHGORA, CASHMERE AND SHEEP, AND BLENDS COMPRISED THEREOF (U.S. CLS. 22 AND 39).

FIRST USE 12-31-2007; IN COMMERCE 12-31-2007.

4,118,780. DISNEY ENTERPRISES, INC., BURBANK, CA. SN 77-106,416. PUB. 2-19-2008, FILED 2-13-2007.

PIGLET

THE MARK CONSISTS OF STANDARD CHARACTERS WITHOUT CLAIM TO ANY PARTICULAR FONT, STYLE, SIZE, OR COLOR.

CLASS 14—JEWELRY

FOR JEWELRY, WATCHES, CLOCKS, JEWELRY BOXES NOT MADE OF PRECIOUS METALS (U.S. CLS. 2, 27, 28 AND 50).

FIRST USE 10-19-2009; IN COMMERCE 10-19-2009.

CLASS 18—LEATHER GOODS

FOR ARTICLES MADE FROM LEATHER AND IMITATIONS OF LEATHER, NAMELY, LUGGAGE, AND SATCHELS; BAGS, NAMELY, BACKPACKS, BOOK BAGS AND DUFFEL BAGS; SHOPPING BAGS OF TEXTILE; TOTE BAGS; PURSES; HANDBAGS; UMBRELLAS (U.S. CLS. 1, 2, 3, 22 AND 41).

FIRST USE 10-19-2009; IN COMMERCE 10-19-2009.

CLASS 20—FURNITURE AND ARTICLES NOT OTHERWISE CLASSIFIED

FOR PICTURE FRAMES; PILLOWS (U.S. CLS. 2, 13, 22, 25, 32 AND 50).

FIRST USE 10-19-2009; IN COMMERCE 10-19-2009.

CLASS 21—HOUSEWARES AND GLASS

FOR HOUSEWARES, NAMELY, BOWLS, COOKIE CUTTERS, CUPS, DISHES, MUGS, PLATES, SPORTS BOTTLES SOLD EMPTY, AND THERMAL INSULATED CONTAINERS FOR FOOD OR BEVERAGE; DINNERWARE; BEVERAGEWARE; PLASTIC CUPS; COOKIE JARS (U.S. CLS. 2, 13, 23, 29, 30, 33, 40 AND 50).

FIRST USE 10-19-2009; IN COMMERCE 10-19-2009.

CLASS 24—FABRICS

FOR BED SHEETS, BLANKET THROWS, COMFORTERS, KITCHEN TOWELS, OVEN MITTS, PILLOW CASES, THROWS, TOWELS, BED LINEN, HOUSEHOLD LINEN (U.S. CLS. 42 AND 50).

FIRST USE 10-19-2009; IN COMMERCE 10-19-2009.

CLASS 25—CLOTHING

FOR CLOTHING, NAMELY, APRONS, GLOVES, HALLOWEEN COSTUMES, INFANTWEAR, JACKETS, NIGHT SHIRTS, NIGHT GOWNS, PAJAMAS, PANTS, POLO SHIRTS, RAINWEAR, ROBES, SHIRTS, SKIRTS, SHORTS, SLIPPERS, SLEEPWEAR, SWEAT SHIRTS, SWIMSUITS, TANK TOPS, T-SHIRTS AND UNDERWEAR; FOOTWEAR AND HEADWEAR (U.S. CLS. 22 AND 39).

FIRST USE 10-20-2009; IN COMMERCE 10-20-2009.

CLASS 28—TOYS AND SPORTING GOODS

FOR TOYS, GAMES, AND PLAYTHINGS, NAMELY, TOY ACTION FIGURES AND ACCESSORIES THEREFOR; BOARD GAMES; CARD GAMES; BATH TOYS; BEAN BAG DOLLS; TOY BUILDING BLOCKS; CHILDREN'S PLAY COSMETICS; CHRISTMAS TREE DECORATIONS EXCEPT CONFECTIONARY OR ILLUMINATION ARTICLES; CHRISTMAS TREE ORNAMENTS; COLLECTABLE TOY FIGURES; DOLLS; DOLL CLOTHING; DOLL ACCESSORIES; DOLL PLAYSETS; ELECTRIC ACTION TOYS; PLUSH TOYS; SNOW GLOBES; SQUEEZE TOYS; STUFFED TOYS; TALKING TOYS; TEDDY BEARS; TOY VEHICLES; TOY CARS; TOY FIGURES; TOY BANKS; TOY TRUCKS; WIND-UP TOYS (U.S. CLS. 22, 23, 38 AND 50).

FIRST USE 10-19-2009; IN COMMERCE 10-19-2009.

CLASS 41—EDUCATION AND ENTERTAINMENT

FOR ENTERTAINMENT SERVICES, NAMELY, PRODUCTION AND DISTRIBUTION OF MOTION PICTURE FILMS; PRODUCTION OF TELEVISION PROGRAMS; PRODUCTION OF SOUND AND VIDEO RECORDINGS (U.S. CLS. 100, 101 AND 107).

FIRST USE 2-18-2011; IN COMMERCE 2-18-2011.

4,118,785. FRANK RUSSELL COMPANY, SEATTLE, WA. SN 77-204,378. PUB. 4-29-2008, FILED 6-12-2007.

**One World. One Approach.
One Index.**

THE MARK CONSISTS OF STANDARD CHARACTERS WITHOUT CLAIM TO ANY PARTICULAR FONT, STYLE, SIZE, OR COLOR.

NO CLAIM IS MADE TO THE EXCLUSIVE RIGHT TO USE "INDEX", APART FROM THE MARK AS SHOWN.

CLASS 9—ELECTRICAL AND SCIENTIFIC APPARATUS

FOR DOWNLOADABLE ELECTRONIC PUBLICATIONS, NAMELY, PUBLICATIONS IN THE NATURE OF LISTINGS OF INVESTMENT SECURITIES AND AN INDEX BASED ON SECURITIES VALUES; DOWNLOADABLE ELECTRONIC FINANCIAL PUBLICATIONS, NAMELY, BOOKLETS, NEWSLETTERS, BROCHURES, AND REPORTS RELATING TO INVESTMENT SECURITIES AND AN INDEX OF SECURITIES VALUES; ELECTRONIC, MAGNETIC, OPTICAL AND OTHER MACHINE-READABLE MEDIA, NAMELY, COMPACT DISKS AND MAGNETIC DISKS FEATURING FINANCIAL INFORMATION FOR USE IN THE FINANCIAL AND INVESTMENT FIELDS; AUDIO VISUAL RECORDINGS, NAMELY, AUDIO VISUAL RECORDINGS IN THE FINANCIAL AND INVESTMENT FIELDS (U.S. CLS. 21, 23, 26, 36 AND 38).

FIRST USE 1-0-2008; IN COMMERCE 1-0-2008.

CLASS 36—INSURANCE AND FINANCIAL

FOR FINANCIAL SERVICES IN THE NATURE OF AN INVESTMENT SECURITY; FINANCIAL CONSULTING SERVICES; AND PROVIDING FINANCIAL INFORMATION BY ELECTRONIC MEANS (U.S. CLS. 100, 101 AND 102).

FIRST USE 1-0-2008; IN COMMERCE 1-0-2008.

4,118,786. UNITEDHEALTH GROUP INCORPORATED, MINNETONKA, MN. SN 77-207,652. PUB. 11-27-2007, FILED 6-15-2007.

OPTUMHEALTH BANK

THE MARK CONSISTS OF STANDARD CHARACTERS WITHOUT CLAIM TO ANY PARTICULAR FONT, STYLE, SIZE, OR COLOR.

OWNER OF U.S. REG. NOS. 1,801,041, 2,679,582, AND OTHERS.

NO CLAIM IS MADE TO THE EXCLUSIVE RIGHT TO USE "BANK", APART FROM THE MARK AS SHOWN.

CLASS 35—ADVERTISING AND BUSINESS

FOR ADMINISTRATION AND RECONCILIATION OF ACCOUNTS ON BEHALF OF OTHERS (U.S. CLS. 100, 101 AND 102).

FIRST USE 1-15-2002; IN COMMERCE 1-15-2002.

CLASS 36—INSURANCE AND FINANCIAL

FOR FINANCIAL SERVICES, NAMELY, BANKING SERVICES, CREDIT CARD SERVICES, DEBIT CARD SERVICES, ISSUING STORED VALUE CARDS, ADMINISTERING DEPOSIT AND MEDICAL SPENDING ACCOUNTS, ELECTRONIC FUNDS TRANSFER; BUSINESS BANKING SERVICES; CREDIT AND DEBIT CARD TRANSACTION PROCESSING SERVICES; INVESTMENT CONSULTATION; ONLINE BANKING SERVICES; ONLINE BUSINESS BANKING SERVICES; BILL PAYMENT SERVICES; ELECTRONIC PROCESSING AND TRANSMISSION OF BILL PAYMENT DATA; PROVIDING INFORMATION REGARDING BANKING, CREDIT, MONEY MANAGEMENT, INVESTING, INVESTMENTS AND FINANCIAL MATTERS; COUNSELING IN THE FIELD OF BANKING AND FINANCIAL SERVICES; PROVISION OF CONSOLIDATED REPORTS OF BANKING AND FINANCIAL ACTIVITY; ADMINISTRATION, FINANCIAL MANAGEMENT AND MAINTENANCE OF HEALTH SAVINGS ACCOUNTS AND MEDICAL SAVINGS ACCOUNTS (U.S. CLS. 100, 101 AND 102).

FIRST USE 1-15-2002; IN COMMERCE 1-15-2002.

4,118,787. UNITEDHEALTH GROUP INCORPORATED, MINNETONKA, MN. SN 77-207,674. PUB. 11-27-2007, FILED 6-15-2007.

**OPTUMHEALTH FINANCIAL
SERVICES**

THE MARK CONSISTS OF STANDARD CHARACTERS WITHOUT CLAIM TO ANY PARTICULAR FONT, STYLE,

SIZE, OR COLOR.

OWNER OF U.S. REG. NOS. 1,801,041, 2,679,582, AND OTHERS.

NO CLAIM IS MADE TO THE EXCLUSIVE RIGHT TO USE "FINANCIAL SERVICES", APART FROM THE MARK AS SHOWN.

CLASS 35—ADVERTISING AND BUSINESS

FOR ADMINISTRATION AND RECONCILIATION OF ACCOUNTS ON BEHALF OF OTHERS (U.S. CLS. 100, 101 AND 102).

FIRST USE 11-30-2001; IN COMMERCE 11-30-2001.

CLASS 36—INSURANCE AND FINANCIAL

FOR INSURANCE AND FINANCIAL SERVICES, NAMELY, VERIFYING INSURANCE ELIGIBILITY, PROCESSING AND FACILITATING INSURANCE CO-PAYMENT TRANSACTIONS, ADMINISTRATION OF EMPLOYEE BENEFITS PLANS, BANKING RELATED SERVICES, CREDIT CARD SERVICES, DEBIT CARD SERVICES, ISSUING STORED VALUE CARDS, ADMINISTERING DEPOSIT AND MEDICAL SPENDING ACCOUNTS, ELECTRONIC FUNDS TRANSFER, ADMINISTRATION OF DEFINED CONTRIBUTION PLANS, ADMINISTRATION OF HEALTH CARE PLANS, MANAGEMENT OF REVENUE AND EXPENSE TRANSACTIONS FOR PROVIDERS OF HEALTH AND MEDICAL PRODUCTS AND SERVICES; BROKERAGE AND MANAGEMENT SERVICES; ACCOUNTS PAYABLE SERVICES; COMMERCIAL LENDING SERVICES; BILL PAYMENT SERVICES; ELECTRONIC PROCESSING AND TRANSMISSION OF BILL PAYMENT DATA; PROVIDING INFORMATION REGARDING BANKING AND CREDIT; COUNSELING IN THE FIELD OF BANKING AND FINANCIAL SERVICES; PROVISION OF CONSOLIDATED REPORTS OF BANKING AND FINANCIAL ACTIVITY; HEALTH REIMBURSEMENT ARRANGEMENTS AND FLEXIBLE SPENDING ACCOUNTS; OFFERING CONSUMER-DRIVEN HEALTH CARE PLANS, NAMELY, UNDERWRITING, ADMINISTRATION, FINANCING, AND MAINTENANCE OF CONSUMER-DRIVEN HEALTH CARE PLANS AND DEFINED CONTRIBUTION HEALTH CARE PLANS; INSURANCE CLAIMS ADMINISTRATION; INSURANCE CLAIMS PROCESSING (U.S. CLS. 100, 101 AND 102).

FIRST USE 11-30-2001; IN COMMERCE 11-30-2001.

4,118,795. OMIDYAR NETWORK COMMONS, LLC, REDWOOD CITY, CA. SN 77-308,211. PUB. 4-7-2009, FILED 10-19-2007.



THE COLOR(S) ORANGE, BROWN, GREEN, YELLOW AND RED IS/ARE CLAIMED AS A FEATURE OF THE MARK.

THE MARK CONSISTS OF IRREGULARLY SHAPED HORIZONTAL STRIPES IN DIFFERENT COLORS FORMING ROUGHLY THE APPEARANCE OF A CIRCLE. THE COLOR ORANGE APPEARS IN THE SHAPE AT THE TOP OF THE DESIGN. THE COLOR BROWN APPEARS IN THE

SHAPE THAT IS SECOND FROM THE TOP OF THE MARK. THE COLOR GREEN APPEARS IN THE SHAPE THAT IS THIRD FROM THE TOP OF THE MARK. THE COLOR RED APPEARS IN THE SHAPE THAT IS SECOND FROM THE BOTTOM OF THE MARK. THE COLOR YELLOW APPEARS IN THE SHAPE AT THE BOTTOM OF THE MARK.

CLASS 35—ADVERTISING AND BUSINESS

FOR PUBLIC POLICY RESEARCH SERVICES AIMED AT ENDING MASS ATROCITIES AND HUMAN SLAVERY; ADVOCATING ON BEHALF OF OTHERS BY PROMOTING PUBLIC AWARENESS OF THE NEED FOR, AND PROMOTING PUBLIC SUPPORT OF AND PARTICIPATION IN EFFORTS AIMED AT ENDING MASS ATROCITIES AND HUMAN SLAVERY; ADVOCATING ON BEHALF OF OTHERS BY CONDUCTING MARKET AND PUBLIC POLICY RESEARCH AND ANALYSIS, NAMELY, INFORMATION GATHERING, STUDY, FIELD-BASED ANALYSIS, INVESTIGATION OF NEW APPROACHES, AND ITERATIVE REFINEMENT OF IDEAS AND PLANS IN COLLABORATION WITH OTHERS, ALL TO PROMOTE THE DEVELOPMENT OF SOLUTIONS FOR THE PROTECTION OF HUMAN RIGHTS AND THE PROMOTION OF HUMAN DIGNITY; ADVOCATING ON BEHALF OF OTHERS THROUGH LOBBYING OF COMMERCIAL, NOT-FOR-PROFIT, GOVERNMENTAL, AND NON-GOVERNMENTAL ORGANIZATIONS IN SUPPORT OF ADOPTING AND SUPPORTING MEASURES FOR THE PROTECTION OF HUMAN RIGHTS AND THE PROMOTION OF HUMAN DIGNITY; ADVISORY AND CONSULTANCY SERVICES TO INDIVIDUALS AND ORGANIZATIONS ENGAGED IN PUBLIC ADVOCACY TO PROMOTE AWARENESS OF THE NEED FOR HUMAN RIGHTS PROTECTIONS AND PROMOTION OF HUMAN DIGNITY; CHARITABLE SERVICES, NAMELY, ORGANIZING NETWORKS OF INDIVIDUALS AND INSTITUTIONS WITH THE PURPOSE OF FACILITATING AND FURTHERING THE IMPLEMENTATION OF CHARITABLE AND PHILANTHROPIC PROGRAMS; ADMINISTRATION AND MANAGEMENT OF RESEARCH GRANTS; EDUCATION LEADERSHIP DEVELOPMENT; MARKET RESEARCH; PUBLIC OPINION POLLING; PUBLIC OPINION SURVEYS; CONDUCTING MARKET RESEARCH SURVEYS; PROMOTING PUBLIC AWARENESS OF HUMAN NEEDS, NAMELY, PROMOTING PUBLIC AWARENESS OF THE SCOPE OF, THE NEED TO ADDRESS, INSTITUTIONAL OBSTACLES TO, SOLUTIONS FOR, AND THE ROLE OF VARIOUS ACTORS IN RELATION TO THREATS TO BASIC HUMAN RIGHTS, MASS ATROCITIES, HUMAN SLAVERY AND HUMAN CRUELTY; EMPLOYMENT AND NETWORK RECRUITING, NAMELY, RECRUITING PROFESSIONALS, VOLUNTEERS AND WORKERS IN THE FIELD OF CHARITABLE ACTIVITIES RELATING TO ENDING MASS ATROCITIES AND HUMAN SLAVERY, RELIEF OF POVERTY AND HUNGER, HEALTH AND ACCESS TO MEDICAL CARE, EDUCATION AND SOCIAL WELFARE, HUMAN RIGHTS AND MOBILITY, AND DISASTER RELIEF; PROMOTING ECONOMIC DEVELOPMENT IN DEVELOPING COUNTRIES THROUGH THE PROVISION OF BUSINESS AND MANAGERIAL CONSULTATION, INFORMATION, ADVOCACY AND SUPPORT FOR PLANNING, ORGANIZING, MONITORING AND IMPLEMENTING PROJECTS AIMED AT BUILDING ENDURING INSTITUTIONS AND PRACTICES, ENCOURAGING GROWTH AND ENTREPRENEURSHIP THROUGH MICROFINANCE AND OTHER FORMS OF CREDIT, ENSURING ACCOUNTABILITY, AND SUPPORTING ECONOMIC AND POLITICAL STABILITY BY ADDRESSING BASIC HUMAN RIGHTS; CHARITABLE SERVICES, NAMELY, SUPPORTING NETWORKS OF CHARITABLE AND PHILANTHROPIC INDIVIDUALS AND INSTITUTIONS BY PROVIDING CONSULTATION AND ADVICE REGARDING ADVERTISING, AND CREATION AND DISSEMINATION OF ADVERTISING MATERIALS FOR EDUCATIONAL ACTIVITIES AND ENTERTAINMENT EVENTS, WITH THE PURPOSE OF FACILITATING AND FURTHERING THE IMPLEMENTATION OF CHARITABLE AND PHILANTHROPIC PROGRAMS (U.S. CLS. 100, 101 AND 102).

FIRST USE 7-1-2008; IN COMMERCE 7-1-2008.

CLASS 36—INSURANCE AND FINANCIAL

FOR CHARITABLE FUNDRAISING; PHILANTHROPIC SERVICES CONCERNING MONETARY DONATIONS; PROVIDING GRANTS AND MONETARY DONATIONS TO ORGANIZATIONS AND INDIVIDUALS PROMOTING AWARENESS OF, ORGANIZING RESPONSES TO, AND PROVIDING SERVICES TO ADDRESS MASS ATROCITIES, HUMAN SLAVERY, HUMAN CRUELTY, THE PROTECTION OF HUMAN RIGHTS AND THE PROMOTION OF HUMAN DIGNITY; PROVIDING GRANTS AND MONETARY DONATIONS TO ORGANIZATIONS AND INDIVIDUALS WORKING TO BUILD ENDURING INSTITUTIONS AND PRACTICES TO REDUCE THE INCIDENCE AND LIMIT THE IMPACT OF MASS ATROCITIES AND OTHER VIOLATIONS OF BASIC HUMAN RIGHTS; PROVIDING GRANTS AND MONETARY DONATIONS TO ORGANIZATIONS AND INDIVIDUALS WORKING TO MOVE PUBLIC POLICY AND POLITICAL WILL TOWARD PRODUCTIVE INTERVENTION TO PREVENT OR STOP MASS ATROCITIES AND OTHER VIOLATIONS OF BASIC HUMAN RIGHTS; CHARITABLE SERVICES, NAMELY, PROVIDING GRANTS AND MONETARY DONATIONS TO SUPPORT NETWORKS OF INDIVIDUALS AND INSTITUTIONS WITH THE PURPOSE OF FACILITATING AND FURTHERING THE IMPLEMENTATION OF CHARITABLE AND PHILANTHROPIC PROGRAMS (U.S. CLS. 100, 101 AND 102).

FIRST USE 7-1-2008; IN COMMERCE 7-1-2008.

CLASS 41—EDUCATION AND ENTERTAINMENT

FOR DEVELOPMENT AND DISSEMINATION OF EDUCATIONAL MATERIALS TO OTHERS IN THE FIELD OF PROMOTING AWARENESS OF, ORGANIZING RESPONSES TO, AND PROVIDING SERVICES TO ADDRESS MASS ATROCITIES, HUMAN SLAVERY, HUMAN CRUELTY, THE PROTECTION OF HUMAN RIGHTS AND THE PROMOTION OF HUMAN DIGNITY; ARRANGING AND CONDUCTING OF EDUCATIONAL CONFERENCES, DISCUSSIONS, AND COLLOQUIA; ARRANGING AND CONDUCTING OF ONLINE DISCUSSIONS, CONFERENCES, AND COLLOQUIA VIA COMPUTER AND COMMUNICATION NETWORKS IN THE FIELDS OF EDUCATION, COLLABORATION, COORDINATION, AND SUPPORT IN RELATION TO PROMOTING AWARENESS OF, ORGANIZING RESPONSES TO, AND PROVIDING SERVICES TO ADDRESS MASS ATROCITIES, HUMAN SLAVERY, HUMAN CRUELTY, THE PROTECTION OF HUMAN RIGHTS AND THE PROMOTION OF HUMAN DIGNITY (U.S. CLS. 100, 101 AND 107).

FIRST USE 7-1-2008; IN COMMERCE 7-1-2008.

CLASS 45—PERSONAL AND LEGAL SERVICES

FOR ADVOCATING ON BEHALF OF OTHERS, NAMELY, LEGAL CONSULTATION AND LEGAL SERVICES IN THE FIELDS OF NEGOTIATION, PROSECUTION SUPPORT, AND LEGAL REPRESENTATION RELATING TO THE PROTECTION OF HUMAN RIGHTS AND THE PROMOTION OF HUMAN DIGNITY (U.S. CLS. 100 AND 101).

FIRST USE 7-1-2008; IN COMMERCE 7-1-2008.

4,118,796. CHEAPCARIBBEAN.COM, INC., DOYLESTOWN, PA. SN 77-309,495. PUB. 11-4-2008, FILED 10-22-2007.

CARIBBEAN JIM

THE MARK CONSISTS OF STANDARD CHARACTERS WITHOUT CLAIM TO ANY PARTICULAR FONT, STYLE, SIZE, OR COLOR.

NO CLAIM IS MADE TO THE EXCLUSIVE RIGHT TO

USE "CARIBBEAN", APART FROM THE MARK AS SHOWN.

THE NAME SHOWN IN THE MARK IDENTIFIES JAMES HOBBS WHOSE CONSENT IS OF RECORD.

CLASS 39—TRANSPORTATION AND STORAGE

FOR TRAVEL AGENCY SERVICES, NAMELY, MAKING RESERVATIONS AND BOOKINGS FOR TRAVEL AND TRANSPORTATION THROUGH A WEBSITE ON THE INTERNET; COORDINATING TRAVEL ARRANGEMENTS FOR INDIVIDUALS AND GROUPS; AND PROVIDING INFORMATION RELATED TO TRAVEL, CRUISES AND VACATION PACKAGES VIA ELECTRONIC COMMUNICATIONS NETWORKS (U.S. CLS. 100 AND 105).

FIRST USE 8-30-2011; IN COMMERCE 8-30-2011.

CLASS 41—EDUCATION AND ENTERTAINMENT

FOR ENTERTAINMENT SERVICES, NAMELY, VIDEO AND AUDIO PERFORMANCES, LIVE PERFORMANCES AND PERSONAL APPEARANCES, CONDUCTING PROGRAMS, TELEVISION SHOWS, AND RADIO SHOWS RELATING TO TRAVEL; PROVIDING INFORMATION RELATING TO TRAVEL THROUGH SEMINARS, CONFERENCES, AND WORKSHOPS (U.S. CLS. 100, 101 AND 107).

FIRST USE 3-10-2007; IN COMMERCE 3-10-2007.

CLASS 43—HOTEL AND RESTAURANT SERVICES

FOR TRAVEL AGENCY SERVICES, NAMELY, MAKING RESERVATIONS AND BOOKINGS FOR TEMPORARY LODGING THROUGH A WEBSITE ON THE INTERNET; AND PROVIDING INFORMATION REGARDING HOTELS VIA ELECTRONIC COMMUNICATIONS NETWORKS (U.S. CLS. 100 AND 101).

FIRST USE 8-30-2011; IN COMMERCE 8-30-2011.

4,118,809. ROWLEY BROTHERS, INC., BAY CITY, MI. SN 77-374,452. PUB. 8-31-2010, FILED 1-17-2008.

TECHSELECT

THE MARK CONSISTS OF STANDARD CHARACTERS WITHOUT CLAIM TO ANY PARTICULAR FONT, STYLE, SIZE, OR COLOR.

OWNER OF U.S. REG. NO. 3,109,653.

CLASS 1—CHEMICALS

FOR AUTOMOTIVE FLUIDS, NAMELY, ANTI-FREEZE; AUTOMOTIVE CHEMICALS IN LIQUID FORM, NAMELY, WINDSHIELD WASHER DE-ICING SOLVENT, BRAKE FLUID, AND POWER STEERING FLUID (U.S. CLS. 1, 5, 6, 10, 26 AND 46).

FIRST USE 11-2-2001; IN COMMERCE 11-2-2001.

CLASS 2—PAINTS

FOR AUTOMOTIVE AFTERMARKET PARTS, NAMELY, UNDERCOATING FOR VEHICLE CHASSIS AND BODY PANELS (U.S. CLS. 6, 11 AND 16).

FIRST USE 6-10-2002; IN COMMERCE 6-10-2002.

CLASS 3—COSMETICS AND CLEANING PREPARATIONS

FOR AUTOMOTIVE CHEMICALS IN LIQUID FORM, NAMELY, WINDSHIELD WASHER CLEANING SOLVENT, BRAKE CLEANER; AND AUTOMOTIVE CHEMICALS IN AEROSOL FORM, NAMELY, VEHICLE CARPET CLEANER, GLASS CLEANER, SPOT REMOVER, CARBURETOR SPRAY, AND FUEL INJECTOR THROTTLE BODY CLEANER; INDUSTRIAL AND GENERAL PURPOSE JANITORIAL SUPPLIES, NAMELY, CLEANING PREPARATIONS (U.S. CLS. 1, 4, 6, 50, 51 AND 52).

FIRST USE 7-30-2008; IN COMMERCE 7-30-2008.

CLASS 4—LUBRICANTS AND FUELS

FOR AUTOMOTIVE, INDUSTRIAL, AND GENERAL PURPOSE LUBRICANTS, NAMELY, GEAR LUBRICANTS FOR AUTOMOBILES, GEAR LUBRICANTS FOR INDUSTRIAL MACHINERY, GENERAL PURPOSE GEAR LUBRICANTS, INDUSTRIAL WAY LUBRICANTS AND GENERAL PURPOSE WAY LUBRICANTS (U.S. CLS. 1, 6 AND 15).

FIRST USE 11-2-2001; IN COMMERCE 11-2-2001.

CLASS 16—PAPER GOODS AND PRINTED MATTER

FOR INDUSTRIAL AND GENERAL PURPOSE PAPER GOODS, NAMELY, PAPER TOWELS, PAPER HAND-TOWELS (U.S. CLS. 2, 5, 22, 23, 29, 37, 38 AND 50).

FIRST USE 4-1-2010; IN COMMERCE 4-1-2010.

CLASS 37—CONSTRUCTION AND REPAIR

FOR AUTOMOTIVE SERVICES, NAMELY, CAR-WASHES, APPEARANCE DETAILING, AND VEHICLE UNDERCOATING (U.S. CLS. 100, 103 AND 106).

FIRST USE 6-10-2002; IN COMMERCE 6-10-2002.

4,118,835. METZGERMEISTER & RESEARCH CORP., CIALES, PUERTO RICO. SN 77-473,234. PUB. 5-12-2009, FILED 5-13-2008.



NO CLAIM IS MADE TO THE EXCLUSIVE RIGHT TO USE "CARIBBEAN CHEF", APART FROM THE MARK AS SHOWN.

THE MARK CONSISTS OF AN OVERWEIGHT CHEF WITH A CHEF HAT MAKING AN OKAY SIGN GESTURE WITH HIS HAND; THE WORDS "CARIBBEAN CHEF" AND "THE HIDDEN TROPICAL COUSINE" ARE AT THE BOTTOM OF THE LOGO.

THE ENGLISH TRANSLATION OF "COUSINE" IN THE MARK IS COUSIN.

CLASS 29—MEATS AND PROCESSED FOODS

FOR MEATBALLS (U.S. CL. 46).
FIRST USE 1-10-2005; IN COMMERCE 1-10-2005.

CLASS 30—STAPLE FOODS

FOR LASAGNA (U.S. CL. 46).
FIRST USE 11-12-2011; IN COMMERCE 11-12-2011.

4,118,838. CHERI L. SIMMONS, SACRAMENTO, CA. SN 77-480,794. PUB. 10-21-2008, FILED 5-21-2008.

RAW MOXIE

THE MARK CONSISTS OF STANDARD CHARACTERS WITHOUT CLAIM TO ANY PARTICULAR FONT, STYLE, SIZE, OR COLOR.

CLASS 41—EDUCATION AND ENTERTAINMENT

FOR EDUCATIONAL SERVICES, NAMELY, CONDUCTING LIVE AND ONLINE CLASSES, SEMINARS AND CONFERENCES IN THE FIELD OF HEALTH AND NUTRITION AND DISTRIBUTION OF COURSE MATERIAL IN CONNECTION THEREWITH (U.S. CLS. 100, 101 AND 107).

FIRST USE 10-25-2008; IN COMMERCE 10-25-2008.

CLASS 44—MEDICAL, BEAUTY AND AGRICULTURAL SERVICES

FOR FOOD NUTRITION CONSULTATION; PROVIDING A WEB SITE FEATURING INFORMATION ON HEALTH AND NUTRITION (U.S. CLS. 100 AND 101).

FIRST USE 10-25-2008; IN COMMERCE 10-25-2008.

CLASS 45—PERSONAL AND LEGAL SERVICES

FOR PERSONAL CHEF SERVICES (U.S. CLS. 100 AND 101).

FIRST USE 10-25-2008; IN COMMERCE 10-25-2008.

4,118,840. ECO INNOCENCE, INC., LAS VEGAS, NV. SN 77-484,990. PUB. 10-28-2008, FILED 5-28-2008.

ECO-INNOCENCE

THE MARK CONSISTS OF STANDARD CHARACTERS WITHOUT CLAIM TO ANY PARTICULAR FONT, STYLE, SIZE, OR COLOR.

CLASS 24—FABRICS

FOR BATH TOWELS; BED SHEETS; BURP CLOTHS; CHILDREN'S BLANKETS; CHILDREN'S TOWELS; COMFORTERS; HOODED TOWELS; RECEIVING BLANKETS; WASH CLOTHS (U.S. CLS. 42 AND 50).

FIRST USE 1-13-2012; IN COMMERCE 1-13-2012.

CLASS 25—CLOTHING

FOR BABY BIBS NOT OF PAPER; BABY BODYSUITS; BABY BOTTOMS; BABY TOPS; CAMP SHIRTS; CHILDREN'S AND INFANTS' CLOTH BIBS; CHILDREN'S HEADWEAR; INFANT AND TODDLER ONE PIECE CLOTHING; INFANT SLEEPERS; INFANT WEAR; INFANTWEAR; LAYETTES; MITTENS; ONE PIECE GARMENT FOR INFANTS AND TODDLERS; ONE-PIECE PLAY SUITS; PLAY SUITS; SOCKS; SPORT SHIRTS; SPORTS BRA; SWADDLING CLOTHES; T-SHIRTS; YOGA PANTS; YOGA SHIRTS (U.S. CLS. 22 AND 39).

FIRST USE 1-13-2012; IN COMMERCE 1-13-2012.

4,118,841. THOR TECH, INC., JACKSON CENTER, OH. SN 77-486,663. PUB. 4-28-2009, FILED 5-29-2008.

AIRSTREAM

THE MARK CONSISTS OF STANDARD CHARACTERS WITHOUT CLAIM TO ANY PARTICULAR FONT, STYLE, SIZE, OR COLOR.

OWNER OF U.S. REG. NOS. 607,224, 1,597,528, AND OTHERS.

CLASS 9—ELECTRICAL AND SCIENTIFIC APPARATUS

FOR BINOCULARS, SPECTACLES AND EYEWEAR, NAMELY, SUNGLASSES, ACCESSORIES THEREFORE, NAMELY, CORDS, HOLDERS AND CASES; COMPUTER PERIPHERALS AND ACCESSORIES, NAMELY, MOUSE PADS (U.S. CLS. 21, 23, 26, 36 AND 38).

FIRST USE 0-0-2003; IN COMMERCE 0-0-2003.

CLASS 14—JEWELRY

FOR WATCHES, HOLIDAY ORNAMENTS MADE OF PRECIOUS METALS, JEWELRY, CHARMS, AND PINS (U.S. CLS. 2, 27, 28 AND 50).

FIRST USE 0-0-2003; IN COMMERCE 0-0-2003.

4,118,852. EARTH TURNS, LLC, CANTON, CT. SN 77-499,527. PUB. 11-11-2008, FILED 6-16-2008.

FUNDAMENTAL

THE MARK CONSISTS OF STANDARD CHARACTERS WITHOUT CLAIM TO ANY PARTICULAR FONT, STYLE, SIZE, OR COLOR.

CLASS 3—COSMETICS AND CLEANING PREPARATIONS

FOR NATURAL HEALTH PRODUCTS, NAMELY, BODY LOTION, BODY CREAM, FACE CREAM, ANTI-AGING CREAM, BATH SOAPS IN LIQUID, SOLID OR GEL FORM, SHOWER SOAPS IN LIQUID, SOLID OR GEL FORM, SHAMPOO AND CONDITIONER; NATURAL CLEANING PRODUCTS, NAMELY, ALL-PURPOSE AND HOUSEHOLD CLEANING PREPARATIONS, AND CLEANING PREPARATIONS FOR VEGETABLES AND FRUIT (U.S. CLS. 1, 4, 6, 50, 51 AND 52).

FIRST USE 8-1-2011; IN COMMERCE 8-1-2011.

CLASS 5—PHARMACEUTICALS

FOR NUTRITIONAL AND DIETARY SUPPLEMENTS IN THE NATURE OF VITAMINS, MINERALS, ENZYMES, PROBIOTICS, FISH OIL SUPPLEMENTS, OMEGA-3 SUPPLEMENTS, AMINO ACIDS, HERBS, NATURAL AND BOTANICAL INGREDIENTS OR A COMBINATION THEREOF, IN THE FORM OF LIQUIDS, POWDERS, TABLETS, SOFTGELS, CAPSULES AND CAPLETS; NUTRITIONAL AND DIETARY SUPPLEMENTS IN THE NATURE OF VITAMINS, MINERALS, HERBS, NATURAL AND BOTANICAL INGREDIENTS OR A COMBINATION THEREOF, FOR SUPPORTING AND MAINTAINING JOINT HEALTH; NUTRITIONAL AND DIETARY SUPPLEMENTS IN THE NATURE OF VITAMINS, MINERALS, HERBS, NATURAL AND BOTANICAL INGREDIENTS OR A COMBINATION THEREOF, FOR SUPPORTING AND MAINTAINING CARDIOVASCULAR HEALTH; NUTRITIONAL AND DIETARY SUPPLEMENTS IN THE NATURE OF VITAMINS, MINERAL, HERBS, NATURAL AND BOTANICAL INGREDIENTS OR A COMBINATION THEREOF FOR USE IN DETOXIFICATION OF THE BODY AND INCREASED ENERGY (U.S. CLS. 6, 18, 44, 46, 51 AND 52).

FIRST USE 1-0-2008; IN COMMERCE 1-0-2008.

4,118,856. CLEVELAND STATE UNIVERSITY, CLEVELAND, OH. SN 77-502,772. PUB. 5-5-2009, FILED 6-19-2008.



THE MARK CONSISTS OF THE IMAGE OF A VIKING'S HEAD.

CLASS 6—METAL GOODS

FOR KEY RINGS, KEY FOBS, AND KEY CHAINS MADE PRIMARILY OF METAL; METAL LICENSE PLATES (U.S. CLS. 2, 12, 13, 14, 23, 25 AND 50).

FIRST USE 1-23-2012; IN COMMERCE 1-23-2012.

CLASS 16—PAPER GOODS AND PRINTED MATTER

FOR NOTEBOOKS; LOOSE-LEAF BINDERS; FOLDERS; NOTE PADS; WRITING PAPER AND ENVELOPES; DECALS; POSTCARDS; BUMPER STICKERS; CALENDARS; POSTERS; DESK ACCESSORIES, NAMELY, BUSINESS CARD HOLDERS, PENS, PENCILS; FRAMED PICTURES; STICKERS; PAPER NAPKINS; BROCHURES FEATURING UNIVERSITY ACTIVITIES, EVENTS, PROGRAMS, AND SERVICES; AND NEWSLETTERS CONCERNING UNIVERSITY ACTIVITIES AND EVENTS (U.S. CLS. 2, 5, 22, 23, 29, 37, 38 AND 50).
FIRST USE 1-23-2012; IN COMMERCE 1-23-2012.

CLASS 18—LEATHER GOODS

FOR TOTE BAGS; BACKPACKS; ALL PURPOSE SPORTS BAGS; WALLETS; IDENTIFICATION CARD CASES; CREDIT CARD CASES; GYM BAGS; DUFFEL BAGS; AND TRAVEL BAGS (U.S. CLS. 1, 2, 3, 22 AND 41).
FIRST USE 1-23-2012; IN COMMERCE 1-23-2012.

CLASS 21—HOUSEWARES AND GLASS

FOR DRINKING MUGS; BEVERAGE CONTAINER INSULATORS; GLASSES; CUPS; AND TUMBLERS (U.S. CLS. 2, 13, 23, 29, 30, 33, 40 AND 50).
FIRST USE 1-23-2012; IN COMMERCE 1-23-2012.

CLASS 24—FABRICS

FOR BLANKETS; TOWELS; AND BANNERS AND PENNANTS ALL MADE OF CLOTH (U.S. CLS. 42 AND 50).
FIRST USE 1-23-2012; IN COMMERCE 1-23-2012.

CLASS 25—CLOTHING

FOR CLOTHING FOR MEN, WOMEN AND CHILDREN, NAMELY, CLOTH AND PLASTIC BABY BIBS, DRESSES, EAR MUFFS, HATS, HEADBANDS, JACKETS, JERSEYS, PAJAMAS, PANTS, SHIRTS, SHORTS, SOCKS, SWEATBANDS, SWEATPANTS, SWEATSHIRTS, SWEATERS, T-SHIRTS, VESTS, AND WARM-UP SUITS (U.S. CLS. 22 AND 39).
FIRST USE 1-23-2012; IN COMMERCE 1-23-2012.

4,118,864. SUPER SPROWTZ, LLC, NEW YORK, NY. SN 77-541,776. PUB. 1-20-2009, FILED 8-7-2008.

Super Sprowtz

THE MARK CONSISTS OF STANDARD CHARACTERS WITHOUT CLAIM TO ANY PARTICULAR FONT, STYLE, SIZE, OR COLOR.

CLASS 16—PAPER GOODS AND PRINTED MATTER

FOR PRINTED MATERIALS, NAMELY, BOOKS IN THE FIELD OF NUTRITION AND WELLNESS; CARTOON STRIPS; COMIC BOOKS; GRAPHIC NOVELS; STATIONERY; PRINTED SCHOOL AND OFFICE SUPPLIES, NAMELY, PAPER STATIONERY AND COMPOSITION BOOKS (U.S. CLS. 2, 5, 22, 23, 29, 37, 38 AND 50).
FIRST USE 12-1-2010; IN COMMERCE 12-1-2010.

CLASS 41—EDUCATION AND ENTERTAINMENT

FOR ENTERTAINMENT AND EDUCATIONAL SERVICES, NAMELY, PROVIDING A SERIES OF SHORT SHOWS AND STORIES FEATURING EDUCATIONAL TOPICS RELATING TO NUTRITION AND WELLNESS PROVIDED THROUGH BROADCAST AND CABLE TELEVISION, MOVIES, AND WEBCASTS (U.S. CLS. 100, 101 AND 107).
FIRST USE 12-1-2010; IN COMMERCE 12-1-2010.

4,118,870. NAMCO BANDAI GAMES INC., TOKYO, JAPAN. SN 77-559,478. PUB. 11-25-2008, FILED 8-29-2008.

BARADUKE

THE MARK CONSISTS OF STANDARD CHARACTERS WITHOUT CLAIM TO ANY PARTICULAR FONT, STYLE, SIZE, OR COLOR.

THE WORDING "BARADUKE" HAS NO MEANING IN A FOREIGN LANGUAGE.

CLASS 9—ELECTRICAL AND SCIENTIFIC APPARATUS

FOR COMPUTER GAME PROGRAMS (U.S. CLS. 21, 23, 26, 36 AND 38).
FIRST USE 9-5-1997; IN COMMERCE 11-10-1997.

CLASS 41—EDUCATION AND ENTERTAINMENT

FOR ENTERTAINMENT, NAMELY, PROVIDING A COMPUTER GAME THAT MAY BE ACCESSED NETWORK-WIDE BY NETWORK USERS VIA MOBILE PHONES AND COMPUTERS; PROVIDING COMPUTER GAMES VIA NETWORK BETWEEN COMMUNICATIONS NETWORKS AND COMPUTERS (U.S. CLS. 100, 101 AND 107).
FIRST USE 11-4-2008; IN COMMERCE 11-4-2008.

4,118,873. VAL-MATIC VALVE AND MANUFACTURING CORPORATION, ELMHURST, IL. SN 77-567,848. PUB. 1-27-2009, FILED 9-11-2008.

FLOTROL

THE MARK CONSISTS OF STANDARD CHARACTERS WITHOUT CLAIM TO ANY PARTICULAR FONT, STYLE, SIZE, OR COLOR.

CLASS 7—MACHINERY

FOR PNEUMATIC VALVE ACTUATORS; HYDRAULIC VALVE ACTUATORS (U.S. CLS. 13, 19, 21, 23, 31, 34 AND 35).
FIRST USE 1-30-2012; IN COMMERCE 1-30-2012.

CLASS 9—ELECTRICAL AND SCIENTIFIC APPARATUS

FOR ELECTRIC VALVE ACTUATORS (U.S. CLS. 21, 23, 26, 36 AND 38).
FIRST USE 1-30-2012; IN COMMERCE 1-30-2012.

4,118,905. AUDIBLE, INC., NEWARK, NJ. SN 77-703,983.
PUB. 5-10-2011, FILED 4-1-2009.

4,118,902. NFI INDUSTRIES, INC., VINELAND, NJ. SN 77-694,930. PUB. 9-22-2009, FILED 3-19-2009.



OWNER OF U.S. REG. NOS. 3,411,514 AND 3,411,518.
NO CLAIM IS MADE TO THE EXCLUSIVE RIGHT TO USE "REAL ESTATE", APART FROM THE MARK AS SHOWN.

THE COLOR(S) BLUE AND RED IS/ARE CLAIMED AS A FEATURE OF THE MARK.

THE MARK CONSISTS OF THE WORDS "REAL ESTATE" IN BLUE, THE LETTERS "NFI" IN BOLD BLUE FONT BELOW AND TO THE LEFT OF THESE WORDS, A CARTOON OF AN EAGLE TO THE RIGHT IN BLUE WITH THE LETTER "N" IN RED IN ITS CENTER AND TWO RED SWIRLS, ONE ABOVE AND ONE BELOW THE WORDING AND CARTOON.

CLASS 35—ADVERTISING AND BUSINESS

FOR REAL ESTATE SERVICES IN THE FIELD OF INDUSTRIAL BUILDINGS, NAMELY, REAL ESTATE SALES MANAGEMENT OF WAREHOUSES, OFFICES AND INDUSTRIAL BUILDINGS (U.S. CLS. 100, 101 AND 102).

FIRST USE 12-15-2011; IN COMMERCE 12-15-2011.

CLASS 36—INSURANCE AND FINANCIAL

FOR REAL ESTATE SERVICES IN THE FIELD OF INDUSTRIAL BUILDINGS, NAMELY, LEASING OR RENTING OF OFFICE SPACE AND INDUSTRIAL BUILDINGS; REAL ESTATE BROKERAGE SERVICES FOR PROVISION OF THIRD PARTY INDUSTRIAL BUILDINGS; FINANCING SERVICES FOR PURCHASERS OF INDUSTRIAL BUILDINGS (U.S. CLS. 100, 101 AND 102).

FIRST USE 12-15-2011; IN COMMERCE 12-15-2011.

CLASS 37—CONSTRUCTION AND REPAIR

FOR CONSTRUCTION OF WAREHOUSES FOR OTHERS (U.S. CLS. 100, 103 AND 106).

FIRST USE 12-15-2011; IN COMMERCE 12-15-2011.

CLASS 39—TRANSPORTATION AND STORAGE

FOR REAL ESTATE SERVICES IN THE FIELD OF INDUSTRIAL BUILDINGS, NAMELY, LEASING AND RENTAL OF WAREHOUSES (U.S. CLS. 100 AND 105).

FIRST USE 12-15-2011; IN COMMERCE 12-15-2011.



THE MARK CONSISTS OF THREE HALF CIRCLES OVER AN OPEN "V".

CLASS 9—ELECTRICAL AND SCIENTIFIC APPARATUS

FOR COMPUTER SOFTWARE FOR TRANSMITTING, RECEIVING, DOWNLOADING, STREAMING, BROADCASTING, DISPLAYING AND TRANSFERRING AUDIO WORKS, VISUAL WORKS AND MULTIMEDIA WORKS VIA PORTABLE ELECTRONIC DEVICES AND COMPUTERS; COMPUTER SOFTWARE FOR FORMATTING AND CONVERTING AUDIO WORKS, VISUAL WORKS AND MULTIMEDIA WORKS INTO A FORMAT COMPATIBLE WITH PORTABLE ELECTRONIC DEVICES AND COMPUTERS; COMPUTER SOFTWARE ENABLING AUDIO, VISUAL AND OTHER MULTIMEDIA FILES TO BE DOWNLOADED TO AND ACCESSED ON A COMPUTER OR OTHER PORTABLE CONSUMER ELECTRONIC DEVICE; DOWNLOADABLE AUDIO WORKS, VISUAL WORKS AND OTHER MULTIMEDIA WORKS FEATURING BOOKS, MAGAZINES, NEWSPAPERS, PERIODICALS, NEWSLETTERS, JOURNALS AND MANUALS ON A VARIETY OF TOPICS; AUDIO CHILDREN'S BOOKS; AUDIO BABY BOOKS; AUDIO SONG BOOKS; AUDIO BOOKS IN THE FIELD OF FICTION AND NON-FICTION ON A VARIETY OF TOPICS (U.S. CLS. 21, 23, 26, 36 AND 38).

FIRST USE 3-31-2009; IN COMMERCE 3-31-2009.

CLASS 35—ADVERTISING AND BUSINESS

FOR RETAIL STORE SERVICES IN THE FIELD OF AUDIO BOOKS AND RELATED MERCHANDISE; RETAIL STORE SERVICES FEATURING STREAMED AND DOWNLOADABLE AUDIO, VISUAL AND OTHER MULTIMEDIA WORKS; COMPUTERIZED ONLINE ORDERING SERVICES FEATURING THE AUDIO, VISUAL AND MULTIMEDIA WORKS OF OTHERS; DISTRIBUTORSHIP SERVICES IN THE FIELD OF AUDIO, VISUAL AND OTHER MULTIMEDIA WORKS WHICH ARE STREAMED OR DOWNLOADABLE FROM THE INTERNET OR OTHER COMPUTER OR COMMUNICATIONS NETWORK; PROVIDING CONSUMER PRODUCT INFORMATION VIA THE INTERNET OR OTHER COMPUTER OR COMMUNICATIONS NETWORK; PROVIDING A WEBSITE WHERE USERS CAN POST RATINGS, REVIEWS AND RECOMMENDATIONS; ISSUING GIFT CERTIFICATES WHICH CAN BE REDEEMED FOR GOODS OR SERVICES (U.S. CLS. 100, 101 AND 102).

FIRST USE 3-31-2009; IN COMMERCE 3-31-2009.

CLASS 38—COMMUNICATION

FOR STREAMING OF AUDIO, VISUAL AND OTHER MULTIMEDIA WORKS VIA THE INTERNET OR OTHER COMPUTER OR COMMUNICATIONS NETWORK; TELECOMMUNICATIONS SERVICES, NAMELY, ELECTRONIC TRANSMISSION OF STREAMED AND DOWNLOADABLE AUDIO, VISUAL AND OTHER MULTIMEDIA WORKS VIA THE INTERNET OR OTHER COMPUTER OR COMMUNICATIONS NETWORK; TELECOMMUNICATIONS SERVICES, NAMELY, TRANSMISSION OF DATA IN VIDEO AND AUDIO FORMAT VIA THE INTERNET OR OTHER COMPUTER OR COMMUNICATIONS NETWORK; PROVIDING ONLINE CHAT ROOMS, INTERNET FORUMS AND ONLINE COMMUNITIES FOR THE TRANSMISSION OF INFORMATION AND MESSAGES AMONG COMPUTER USERS; DELIVERY OF MESSAGES BY ELECTRONIC TRANSMISSION (U.S. CLS. 100, 101 AND 104).

FIRST USE 3-31-2009; IN COMMERCE 3-31-2009.

CLASS 41—EDUCATION AND ENTERTAINMENT

FOR PROVIDING A WEB SITE FEATURING EDUCATIONAL AND ENTERTAINMENT SERVICES IN THE NATURE OF AUDIO, VISUAL AND OTHER MULTIMEDIA PROGRAMMING ELECTRONICALLY AVAILABLE WITH THE USE OF AN ONLINE INTERACTIVE MENU, SUCH PROGRAMMING FEATURING AUDIO COPIES OF NEWS PROGRAMS, FICTION AND NON-FICTION TEXTUAL WORKS, COMIC AND COMEDY-RELATED CONTENT, RECORDED PODCASTS, RADIO AND TELEVISION PROGRAMS, AUDIO COPIES OF NEWSPAPERS AND MAGAZINES, SPEECHES, LECTURES, AND COMMENTARY ON A BROAD SPECTRUM OF TOPICS; PROVIDING INFORMATION AND COMMENTARY IN THE FIELD OF ENTERTAINMENT OR EDUCATION VIA A GLOBAL COMPUTER NETWORK; ENTERTAINMENT SERVICES, NAMELY, PROVIDING ONLINE NON-DOWNLOADABLE PRERECORDED AUDIO, VISUAL AND OTHER MULTIMEDIA PROGRAMS, FEATURING BOOKS, MAGAZINES, NEWSPAPERS, PERIODICALS, NEWSLETTERS, JOURNALS AND MANUALS ON A VARIETY OF TOPICS; PROVIDING ON-LINE REVIEWS, RATINGS AND RECOMMENDATIONS IN THE FIELD OF BOOKS, MAGAZINES, NEWSPAPERS, PERIODICALS, NEWSLETTERS, JOURNALS, MANUALS AND ENTERTAINMENT (U.S. CLS. 100, 101 AND 107).

FIRST USE 3-31-2009; IN COMMERCE 3-31-2009.

4,118,907. WYNRIGHT CORPORATION, ELK GROVE VILLAGE, IL. SN 77-711,826. PUB. 5-3-2011, FILED 4-10-2009.



THE MARK CONSISTS OF THE TERM "WYNRIGHT" WITH A LINE OF SMALL DIAMONDS ABOVE THE FIRST FOUR LETTERS AND A LARGER CUBE FORMING THE DOT ABOVE THE LETTER "I" IN THE TERM "WYNRIGHT".

CLASS 7—MACHINERY

FOR INTEGRATED MATERIALS HANDLING SYSTEMS AND EQUIPMENT COMPRISED OF ONE OR MORE OF THE FOLLOWING: CONVEYORS, SORTATION EQUIPMENT IN THE NATURE OF TRAP ARM, PUSHER, BOW ARM, FLAT FACE ARM, POP-UP WHEEL, LINE, SLIDING SHOE AND MULTI-BELT SORTATION CONVEYORS TO MERGE, SORT, DISCHARGE, DIVERT AND MOVE CARTONS OR PRODUCT; DIRECTED PICKING SYSTEMS COMPRISED OF UNIT LOAD AND/OR MINI-LOAD AUTOMATED STORAGE AND RETRIEVAL MACHINERY, CAROUSELS, CARTON FLOW RACKS, PICK-TO-LIGHT, PUT-TO-LIGHT AND OTHER PICK STRUCTURES IN THE NATURE OF PICK MODULES AND MACHINERY TO RETRIEVE ITEMS OR PACKAGES, TOGETHER WITH OPERATIONAL SOFTWARE, HARDWARE AND OPERATORS' CONSOLES COMPRISING A COMPUTER MONITOR AND/OR ELECTRICAL CONTROL PANEL ALL SOLD AS A UNIT WITH THE SYSTEM; ELECTRICAL AND PNEUMATIC EQUIPMENT IN THE NATURE OF ROBOTIC MATERIAL HANDLING MACHINERY, NAMELY, ROBOTIC PALLETIZERS AND ROBOTIC TRUCK LOADERS FOR AUTOMATIC AND SEMI-AUTOMATIC STACKING OF CARTONS AND PRODUCT ON PALLETS AND FOR AUTOMATIC AND SEMI-AUTOMATIC LOADING OF CARTONS AND PRODUCT INTO TRUCKS; AND STRUCTURAL PARTS FOR THE FOREGOING, NAMELY, METAL STORAGE RACKS AND MEZZANINES (U.S. CLS. 13, 19, 21, 23, 31, 34 AND 35).

FIRST USE 1-31-2009; IN COMMERCE 1-31-2009.

CLASS 9—ELECTRICAL AND SCIENTIFIC APPARATUS

FOR WAREHOUSE CONTROL SYSTEMS COMPRISED OF PROGRAMMABLE LOGIC CONTROLLERS (PLC) AND PERSONAL COMPUTERS (PC) AND RELATED OPERATIONAL SOFTWARE, INCLUDING PROPRIETARY PLC TO PC INTERFACE, AND HARDWARE SOLD AS A UNIT WITH THE SYSTEM; OPERATORS' CONSOLES COMPRISING A COMPUTER MONITOR AND/OR ELECTRIC CONTROL PANEL (U.S. CLS. 21, 23, 26, 36 AND 38).

FIRST USE 6-2-2009; IN COMMERCE 6-2-2009.

CLASS 37—CONSTRUCTION AND REPAIR

FOR INSTALLATION, INSPECTION, SERVICE, MAINTENANCE AND REPAIR OF MATERIAL HANDLING SYSTEMS AND EQUIPMENT; TECHNICAL SUPPORT SERVICES IN THE NATURE OF TECHNICAL ADVICE RELATED TO ALL OF THE FOREGOING (U.S. CLS. 100, 103 AND 106).

FIRST USE 1-30-2009; IN COMMERCE 1-30-2009.

CLASS 42—SCIENTIFIC AND COMPUTER SERVICES

FOR ENGINEERING, DESIGN AND TESTING FOR OTHERS OF MATERIAL HANDLING SYSTEMS AND EQUIPMENT; INSPECTION OF MATERIAL HANDLING SYSTEMS AND EQUIPMENT; TECHNICAL SUPPORT SERVICES IN THE NATURE OF TECHNICAL ADVICE RELATED TO THE INSPECTION OF MATERIAL HANDLING SYSTEMS AND EQUIPMENT (U.S. CLS. 100 AND 101).

FIRST USE 1-31-2009; IN COMMERCE 1-31-2009.

4,118,910. VICTORIA'S SECRET STORES BRAND MANAGEMENT, INC., REYNOLDSBURG, OH. SN 77-717,571. PUB. 6-29-2010, FILED 4-20-2009.



OWNER OF U.S. REG. NOS. 2,244,265 AND 3,477,955.
THE MARK CONSISTS OF STYLIZED "VS" LOGO.

CLASS 3—COSMETICS AND CLEANING PREPARATIONS

FOR PERSONAL CARE PRODUCTS, NAMELY, BODY LOTIONS; BODY MIST; SHOWER GEL; EAU DE PARFUM; SCENTED BODY POWDER (U.S. CLS. 1, 4, 6, 50, 51 AND 52).

FIRST USE 7-2-2009; IN COMMERCE 7-2-2009.

CLASS 25—CLOTHING

FOR CLOTHING, NAMELY, BRAS; PANTIES; PAJAMAS; LINGERIE, ROBES; SLIPPERS (U.S. CLS. 22 AND 39).

FIRST USE 10-1-2009; IN COMMERCE 10-1-2009.

4,118,915. GRUPO AVAL ACCIONES Y VALORES S.A., SANTAFE DE BOGOTA, COLOMBIA. SN 77-738,680. PUB. 5-4-2010, FILED 5-16-2009.

GRUPO AVAL MORE THAN A BANK

THE MARK CONSISTS OF STANDARD CHARACTERS WITHOUT CLAIM TO ANY PARTICULAR FONT, STYLE, SIZE, OR COLOR.

OWNER OF U.S. REG. NOS. 2,548,694 AND 2,704,910.
THE MARK TRANSLATES TO "GROUP AVAL." THE WORD "AVAL" MEANS - (1) "THE SIGNATURE AT THE END OF A LETTER OR ANY OTHER CREDIT DOCUMENT, TO ASSURE ITS PAYMENT IN CASE THE PERSON WHO IS PRINCIPALLY OBLIGATED DOES NOT PAY"; (2) "WRITTEN DOCUMENT THROUGH WHICH A PERSON RESPONDS FOR SOMEONE ELSE'S BEHAVIOR, ESPECIALLY IN POLITICAL ISSUES."

CLASS 35—ADVERTISING AND BUSINESS

FOR ADVERTISING AND BUSINESS MANAGEMENT CONSULTANCY (U.S. CLS. 100, 101 AND 102).

FIRST USE 7-20-2011; IN COMMERCE 7-20-2011.

CLASS 36—INSURANCE AND FINANCIAL

FOR BANKING AND FINANCING SERVICES; ELECTRONIC BANKING VIA A GLOBAL COMPUTER NETWORK; INVESTMENT BANKING SERVICES; MERCHANT BANKING AND INVESTMENT BANKING SERVICES; MORTGAGE BANKING; ON-LINE BANKING SERVICES (U.S. CLS. 100, 101 AND 102).

FIRST USE 7-20-2011; IN COMMERCE 7-20-2011.

4,118,917. LIVE GREAT FOODS, LLC, MADISON, WI. SN 77-744,184. PUB. 12-1-2009, FILED 5-26-2009.

ACCLAIM

THE MARK CONSISTS OF STANDARD CHARACTERS WITHOUT CLAIM TO ANY PARTICULAR FONT, STYLE, SIZE, OR COLOR.

CLASS 29—MEATS AND PROCESSED FOODS

FOR DAIRY-BASED BEVERAGES CONTAINING CONJUGATED LINOLEIC ACID (U.S. CL. 46).

FIRST USE 3-24-2010; IN COMMERCE 3-24-2010.

CLASS 32—LIGHT BEVERAGES

FOR FRUIT BEVERAGES CONTAINING CONJUGATED LINOLEIC ACID (U.S. CLS. 45, 46 AND 48).

FIRST USE 7-19-2011; IN COMMERCE 7-19-2011.

4,118,922. PREDATOR QUEST, L.L.C., EDGAR, NE. SN 77-752,492. PUB. 6-8-2010, FILED 6-4-2009.



OWNER OF U.S. REG. NO. 3,288,130.

CLASS 9—ELECTRICAL AND SCIENTIFIC APPARATUS

FOR RIFLE SCOPES (U.S. CLS. 21, 23, 26, 36 AND 38).

FIRST USE 9-1-2011; IN COMMERCE 9-1-2011.

CLASS 13—FIREARMS

FOR FIREARM SLINGS; RIFLE SLINGS (U.S. CLS. 2 AND 9).

FIRST USE 9-15-2011; IN COMMERCE 9-15-2011.

CLASS 20—FURNITURE AND ARTICLES NOT OTHERWISE CLASSIFIED

FOR SEAT CUSHIONS (U.S. CLS. 2, 13, 22, 25, 32 AND 50).

FIRST USE 9-1-2011; IN COMMERCE 9-1-2011.

4,118,923. TAKE-TWO INTERACTIVE SOFTWARE, INC., NEW YORK, NY. SN 77-754,144. PUB. 6-1-2010, FILED 6-8-2009.

BIRTHDAY PARTY BASH

THE MARK CONSISTS OF STANDARD CHARACTERS WITHOUT CLAIM TO ANY PARTICULAR FONT, STYLE, SIZE, OR COLOR.

CLASS 9—ELECTRICAL AND SCIENTIFIC APPARATUS

FOR COMPUTER AND VIDEO GAME PROGRAMS AND SOFTWARE; PRE-RECORDED DIGITAL MEDIA FEATURING COMPUTER GAMES AND VIDEO GAMES, GRAPHICS IN THE FIELD OF VIDEO GAMES AND COMPUTER GAMES (U.S. CLS. 21, 23, 26, 36 AND 38).
FIRST USE 7-14-2009; IN COMMERCE 7-14-2009.

CLASS 41—EDUCATION AND ENTERTAINMENT

FOR ENTERTAINMENT SERVICES, NAMELY, PROVIDING A WEBSITE FEATURING NEWS, INFORMATION, TIPS, FILMS, VIDEOS, AND OTHER MULTIMEDIA MATERIALS IN THE FIELD OF COMPUTER GAMES AND VIDEO GAMES; PROVIDING INFORMATION, NEWS AND COMMENTARY IN THE FIELD OF COMPUTER GAMES AND VIDEO GAMES (U.S. CLS. 100, 101 AND 107).
FIRST USE 7-14-2009; IN COMMERCE 7-14-2009.

4,118,932. EXPLORE INFORMATION SERVICES, LLC, EAGAN, MN. SN 77-787,959. PUB. 12-7-2010, FILED 7-23-2009.

Insight That Works

THE MARK CONSISTS OF STANDARD CHARACTERS WITHOUT CLAIM TO ANY PARTICULAR FONT, STYLE, SIZE, OR COLOR.

CLASS 35—ADVERTISING AND BUSINESS

FOR PROVIDING BUSINESS RISK EVALUATION INFORMATION TO INSURANCE COMPANIES; DATA COMPILING IN THE NATURE OF INFORMATION COLLECTION OF DRIVING RECORDS, VEHICLE INFORMATION AND DRIVERS AND PASSENGERS OF MOTORIZED VEHICLES FOR INSURANCE PURPOSES (U.S. CLS. 100, 101 AND 102).
FIRST USE 7-27-2009; IN COMMERCE 7-27-2009.

CLASS 36—INSURANCE AND FINANCIAL

FOR FIRE INSURANCE CONSULTING SERVICES, NAMELY, PROVIDING INSURANCE COVERAGE ANALYSIS BASED ON A DETERMINATION OF THE DISTANCE FROM A FIRE STATION TO SPECIFIC LOCATIONS AND BASED ON THE LOCATION OF FIRE STATIONS, AND PROVIDING A DATABASE IN CONNECTION THEREWITH; INSURANCE CONSULTATION SERVICES, NAMELY, PROVIDING UNDERWRITING AND FINANCIAL RISK OF LOSS EVALUATION INFORMATION TO INSURANCE COMPANIES, AND DETERMINING WHETHER AN INDIVIDUAL OR A BUSINESS HAS INSURANCE CURRENTLY OR HAD INSURANCE AS OF A PARTICULAR DATE FOR THE PURPOSE OF INSURANCE POLICY VERIFICATION (U.S. CLS. 100, 101 AND 102).
FIRST USE 7-27-2009; IN COMMERCE 7-27-2009.

CLASS 45—PERSONAL AND LEGAL SERVICES

FOR PROVIDING DATABASES FOR THE RETRIEVAL OF PUBLIC RECORDS REGARDING UNDISCLOSED MOTORISTS' DRIVING RECORDS PERTAINING TO ACCIDENTS, ARRESTS, AND VEHICLE REGISTRATION INFORMATION (U.S. CLS. 100 AND 101).
FIRST USE 7-27-2009; IN COMMERCE 7-27-2009.

4,118,934. CAIL, MARY MCDANIEL, FREE UNION, VA. SN 77-797,343. PUB. 5-18-2010, FILED 8-5-2009.

THE ALL WEATHER FRIEND

THE MARK CONSISTS OF STANDARD CHARACTERS WITHOUT CLAIM TO ANY PARTICULAR FONT, STYLE, SIZE, OR COLOR.

CLASS 9—ELECTRICAL AND SCIENTIFIC APPARATUS

FOR ELECTRONIC PUBLICATIONS, NAMELY, NON-FICTION BOOKS, BOOKLETS, GUIDES, MANUALS, PAMPHLETS AND BROCHURES, IN THE FIELD OF HELPING PEOPLE MAINTAIN SUPPORTIVE RELATIONSHIPS WITH FRIENDS WHO ARE DEALING WITH DIFFICULT EMOTIONAL, PSYCHOLOGICAL AND MEDICAL PROBLEMS, CONDITIONS, AND CIRCUMSTANCES, RECORDED ON DIGITAL MEDIA, NAMELY, COMPACT DISCS, DIGITAL VIDEO DISCS, AUDIO AND VIDEO CASSETTES AND DOWNLOADABLE FILES (U.S. CLS. 21, 23, 26, 36 AND 38).
FIRST USE 8-29-2011; IN COMMERCE 12-15-2011.

CLASS 16—PAPER GOODS AND PRINTED MATTER

FOR NON-FICTION BOOKS AND OTHER PRINTED MATTER, NAMELY, BOOKLETS, GUIDES, MANUALS, PAMPHLETS AND BROCHURES, IN THE FIELD OF HELPING PEOPLE MAINTAIN SUPPORTIVE RELATIONSHIPS WITH FRIENDS WHO ARE DEALING WITH DIFFICULT EMOTIONAL, PSYCHOLOGICAL AND MEDICAL PROBLEMS, CONDITIONS, AND CIRCUMSTANCES (U.S. CLS. 2, 5, 22, 23, 29, 37, 38 AND 50).
FIRST USE 8-29-2011; IN COMMERCE 9-9-2011.

4,118,939. JUNIPER NETWORKS, INC., SUNNYVALE, CA.
SN 77-817,882. PUB. 6-22-2010, FILED 9-1-2009.



OWNER OF U.S. REG. NOS. 2,255,921, 3,089,694, AND OTHERS.

NO CLAIM IS MADE TO THE EXCLUSIVE RIGHT TO USE "NETWORKS", APART FROM THE MARK AS SHOWN.

THE MARK CONSISTS OF THE STYLIZED WORDS "JUNIPER NETWORKS". "JUNIPER" APPEARS IN LARGE STYLIZED TEXT; THE TERM "NETWORKS" APPEARS IN SMALLER, STYLIZED TEXT BELOW.

CLASS 9—ELECTRICAL AND SCIENTIFIC APPARATUS

FOR COMPUTER HARDWARE AND SOFTWARE, USED ALONE OR IN COMBINATION, FOR INTERCONNECTING, ESTABLISHING, MANAGING, SECURING, MONITORING, TROUBLESHOOTING, CONTROLLING, OPERATING, AND ACCESSING LOCAL, WIDE, AND GLOBAL AREA NETWORKS AND NETWORK INFRASTRUCTURE; COMPUTER HARDWARE AND SOFTWARE, USED ALONE OR IN COMBINATION, FOR ROUTING, SWITCHING, TRANSMITTING, PROCESSING, FILTERING, ANALYZING, SECURING, AND STORING DATA, VIDEO OR VOICE TRAFFIC, PACKETS, OR OTHER FORMS OF COMMUNICATIONS; COMPUTER HARDWARE AND SOFTWARE, USED ALONE OR IN COMBINATION, FOR PROVIDING SECURITY FUNCTIONALITY FOR NETWORKS OR ELECTRONIC DEVICES OR ROUTERS IN NETWORKS, SUCH AS PROVIDING FIREWALL FILTERS, ACCESS CONTROL, VIRTUAL PRIVATE NETWORKS, INTEROPERABILITY WITH ROUTER SECURITY PROTOCOLS, AND PROTECTION AGAINST NETWORK INTRUSION AND VIRUSES; DOWNLOADABLE INSTRUCTIONAL MATERIALS, NAMELY, MANUALS AND GUIDES IN THE FIELDS OF NETWORKING, TELECOMMUNICATIONS, AND NETWORK SECURITY, AND ESTABLISHING, MANAGING, AND OPERATING LOCAL AND WIDE AREA NETWORKS; COMPUTER SOFTWARE, NAMELY, OPERATING SYSTEM SOFTWARE, OPERATING SYSTEM SOFTWARE THAT HOSTS COMPUTER SOFTWARE APPLICATIONS AND FACILITATES INTERACTIONS WITH OTHER COMPUTERS AND PERIPHERALS ACROSS ENTERPRISE NETWORKS; COMPUTER PROGRAMS FOR USE IN ACCESSING, NAVIGATING, DELIVERING, AND TRANSFERRING INFORMATION, AND DISTRIBUTING AND VIEWING COMPUTER PROGRAMS; COMPUTER PROGRAMS FOR USE IN ACCESSING AND VIEWING COMPUTER NETWORK INFRASTRUCTURE AND SYSTEMS; PROGRAMMABLE AND CUSTOMIZABLE COMPUTER SOFTWARE APPLICATION FOR MOBILE DEVICES, TELEVISIONS, AND OTHER VIDEO DEVICES (U.S. CLS. 21, 23, 26, 36 AND 38).

FIRST USE 10-29-2009; IN COMMERCE 10-29-2009.

CLASS 37—CONSTRUCTION AND REPAIR

FOR INSTALLATION, MAINTENANCE, AND REPAIR SERVICES IN THE FIELDS OF COMPUTERS, TELECOMMUNICATIONS, NETWORKING, COMMUNICATIONS, AND NETWORK SECURITY (U.S. CLS. 100, 103 AND 106).

FIRST USE 10-29-2009; IN COMMERCE 10-29-2009.

CLASS 41—EDUCATION AND ENTERTAINMENT

FOR EDUCATIONAL SERVICES, NAMELY, PROVIDING OF TRAINING AND EDUCATIONAL COURSES ON INTERCONNECTING, ESTABLISHING, MANAGING, SECURING, MONITORING, TROUBLESHOOTING, OPERATING, AND ACCESSING COMPUTER HARDWARE AND SOFTWARE, PERIPHERALS, OPERATING SYSTEMS, LOCAL, WIDE, AND GLOBAL AREA NETWORKS, NETWORK INFRASTRUCTURE, WEB BROWSERS, AND ELECTRONIC DEVICES; PROVIDING ONLINE TUTORIAL AND TRAINING SESSIONS IN THE FIELD OF COMPUTER HARDWARE AND SOFTWARE, PERIPHERALS, OPERATING SYSTEMS, LOCAL, WIDE, AND GLOBAL AREA NETWORKS, NETWORK INFRASTRUCTURE, WEB BROWSERS, AND ELECTRONIC DEVICES; DEVELOPING EDUCATIONAL MANUALS FOR OTHERS IN THE FIELD OF COMPUTER HARDWARE AND SOFTWARE, PERIPHERALS, OPERATING SYSTEMS, LOCAL, WIDE, AND GLOBAL AREA NETWORKS, NETWORK INFRASTRUCTURE, WEB BROWSERS, AND ELECTRONIC DEVICES (U.S. CLS. 100, 101 AND 107).

FIRST USE 10-29-2009; IN COMMERCE 10-29-2009.

CLASS 42—SCIENTIFIC AND COMPUTER SERVICES

FOR DESIGN AND DEVELOPMENT OF COMPUTER HARDWARE AND SOFTWARE; COMPUTER PROGRAMMING; PROVIDING CONSULTATION SERVICES FOR DEVELOPING COMPUTER SYSTEMS, AND COMPUTER SOFTWARE AND FIRMWARE, NAMELY, APPLICATION DEVELOPMENT COMPUTER SOFTWARE PROGRAMS; OPERATION, DESIGN AND DEVELOPMENT OF COMPUTER SOFTWARE APPLICATIONS, NAMELY, NETWORK EFFICIENCY IMPROVEMENT SOFTWARE; TECHNICAL SUPPORT SERVICES, NAMELY, TROUBLESHOOTING IN CONNECTION WITH HARDWARE AND SOFTWARE FOR INTERCONNECTING, MANAGING, SECURING, MONITORING, CONTROLLING, OPERATING, AND ACCESSING LOCAL AND WIDE AREA NETWORKS, COMPUTERS, AND TELEPHONY SYSTEMS; DESIGN, TESTING, ENGINEERING, RESEARCH AND ADVISORY SERVICES RELATING TO COMPUTERS, TELECOMMUNICATIONS TECHNOLOGY, TELEPHONY SYSTEMS, NETWORKS, COMPUTER SOFTWARE, COMPUTER HARDWARE, COMPUTER PROGRAMMING, AND NETWORK SECURITY (U.S. CLS. 100 AND 101).

FIRST USE 10-29-2009; IN COMMERCE 10-29-2009.

4,118,960. ASSET CONTROL IRELAND LIMITED, DUBLIN 2, IRELAND. SN 77-866,863. PUB. 1-11-2011, FILED 11-6-2009.



NO CLAIM IS MADE TO THE EXCLUSIVE RIGHT TO USE "INVEST", APART FROM THE MARK AS SHOWN.

THE MARK CONSISTS OF STYLIZED LETTERS "AC" NEXT TO THE WORD "INVEST".

CLASS 9—ELECTRICAL AND SCIENTIFIC APPARATUS

FOR DATABASE MANAGEMENT COMPUTER SOFTWARE FOR USE IN CONNECTION WITH FINANCIAL SERVICES; COMPUTER SOFTWARE FOR USE IN COLLECTION, STORAGE, CLEANSING, VERIFICATION AND DISTRIBUTION OF DATA IN THE FINANCIAL SERVICES FIELD (U.S. CLS. 21, 23, 26, 36 AND 38).

FIRST USE 9-14-2009; IN COMMERCE 9-14-2009.

CLASS 16—PAPER GOODS AND PRINTED MATTER

FOR STATIONERY; PRINTED MATTER AND PRINTED PUBLICATIONS, NAMELY, MANUALS, BROCHURES, GUIDES AND INSTRUCTIONAL AND TEACHING MATERIALS IN THE FIELD OF FINANCIAL AND ENERGY SERVICES; ADVERTISING MATERIAL, NAMELY, CATALOGS AND PAMPHLETS IN THE FIELD OF FINANCIAL AND ENERGY SERVICES (U.S. CLS. 2, 5, 22, 23, 29, 37, 38 AND 50).

FIRST USE 9-14-2009; IN COMMERCE 9-14-2009.

CLASS 35—ADVERTISING AND BUSINESS

FOR COMPUTERIZED DATABASE MANAGEMENT AND DATA PROCESSING SERVICES, NAMELY, COLLOCATION, CHECKING, CLEANSING, ENRICHMENT AND DISTRIBUTION OF DATA; BUSINESS INFORMATION MANAGEMENT SERVICES IN THE FIELD OF FINANCIAL AND ENERGY SERVICES (U.S. CLS. 100, 101 AND 102).

FIRST USE 9-14-2009; IN COMMERCE 9-14-2009.

CLASS 36—INSURANCE AND FINANCIAL

FOR PROVIDING A DATABASE OF FINANCIAL INFORMATION AND FINANCIAL INFORMATION IN THE FIELD OF ENERGY (U.S. CLS. 100, 101 AND 102).

FIRST USE 9-14-2009; IN COMMERCE 9-14-2009.

CLASS 39—TRANSPORTATION AND STORAGE

FOR ELECTRONIC STORAGE OF INFORMATION AND DATA (U.S. CLS. 100 AND 105).

FIRST USE 9-14-2009; IN COMMERCE 9-14-2009.

4,118,961. OHEL CHILDREN'S HOME AND FAMILY SERVICES, INC., BROOKLYN, NY. SN 77-869,115. PUB. 11-23-2010, FILED 11-10-2009.

ELEVATING LIVES EVERY DAY

THE MARK CONSISTS OF STANDARD CHARACTERS WITHOUT CLAIM TO ANY PARTICULAR FONT, STYLE, SIZE, OR COLOR.

CLASS 36—INSURANCE AND FINANCIAL

FOR CHARITABLE FUND RAISING (U.S. CLS. 100, 101 AND 102).

FIRST USE 12-31-2009; IN COMMERCE 12-31-2009.

CLASS 41—EDUCATION AND ENTERTAINMENT

FOR SUMMER CAMPS; ARRANGING PROFESSIONAL WORKSHOPS AND TRAINING COURSES; PROVIDING CLASSES, SEMINARS, WORKSHOPS, AND TRAINING FOR PARENTS, INSTRUCTORS AND OTHER INDIVIDUALS IN THE FIELD OF EDUCATION FOR INDIVIDUALS WITH AUTISM AND OTHER DEVELOPMENTAL DISORDERS; CONDUCTING WORKSHOPS AND SEMINARS IN THE FIELD OF MENTAL HEALTH (U.S. CLS. 100, 101 AND 107).

FIRST USE 12-31-2009; IN COMMERCE 12-31-2009.

CLASS 45—PERSONAL AND LEGAL SERVICES

FOR FOSTER CARE SERVICES; PROVIDING EMOTIONAL COUNSELING AND EMOTIONAL SUPPORT FOR FAMILIES AND PERSONS WITH DEVELOPMENTAL DISABILITIES (U.S. CLS. 100 AND 101).

FIRST USE 12-31-2009; IN COMMERCE 12-31-2009.

4,118,963. THAI WORLD IMPORT & EXPORT CO., LTD., BANGKOK 10120, THAILAND. SN 77-872,459. PUB. 11-2-2010, FILED 11-13-2009.



NO CLAIM IS MADE TO THE EXCLUSIVE RIGHT TO USE "BRAND", APART FROM THE MARK AS SHOWN.

THE MARK CONSISTS OF AN IMAGE OF A ROOSTER ABOVE THE WORDS "GOLDEN COCK BRAND".

CLASS 29—MEATS AND PROCESSED FOODS

FOR COOKED FRUITS AND VEGETABLES; DRIED FRUITS; DRIED VEGETABLES; MILK; MILK PRODUCTS EXCLUDING ICE CREAM, ICE MILK AND FROZEN YOGURT; PRESERVED FRUITS; PRESERVED VEGETABLES; SOUPS (U.S. CL. 46).

FIRST USE 10-10-2011; IN COMMERCE 10-10-2011.

CLASS 30—STAPLE FOODS

FOR ARTIFICIAL COFFEE; BAKING POWDER; BREAD; COCOA; COFFEE; CONFECTIONERY, NAMELY, PASTILLES; CURRY PASTES; CURRY POWDER; FLOUR; HONEY; MUSTARD; PASTRY; PREPARATIONS MADE FROM CEREALS, NAMELY, BREAD ROLLS, BISCUITS, CRACKERS AND BAKERY GOODS; RICE; SAGO; SALT; SAUCES; SPICES; SUGAR; TAPIOCA; TEA; TREACLE; VINEGAR; YEAST (U.S. CL. 46).

FIRST USE 10-10-2011; IN COMMERCE 10-10-2011.

4,118,966. P1 HOLDINGS, LLC, NEW YORK, NY. SN 77-875,491. PUB. 4-26-2011, FILED 11-18-2009.

DFKINGWORLDWIDE

THE MARK CONSISTS OF STANDARD CHARACTERS WITHOUT CLAIM TO ANY PARTICULAR FONT, STYLE, SIZE, OR COLOR.

NO CLAIM IS MADE TO THE EXCLUSIVE RIGHT TO USE "WORLDWIDE", APART FROM THE MARK AS SHOWN.

THE NAME(S), PORTRAIT(S), AND/OR SIGNATURE(S) SHOWN IN THE MARK DOES NOT IDENTIFY A PARTICULAR LIVING INDIVIDUAL.

CLASS 35—ADVERTISING AND BUSINESS

FOR BUSINESS CONSULTATION IN THE FIELDS OF MERGERS AND ACQUISITIONS, TENDER/EXCHANGE OFFERS, SECURITIES REDEMPTIONS; BUSINESS CONSULTATION IN THE FIELDS OF CORPORATE GOVERNANCE, CORPORATE CONTROL, ORGANIZATION, AND CORPORATE ELECTIONS; BUSINESS CONSULTATION IN THE FIELD OF STOCK CONVERSION PROCESSING SERVICES, NAMELY, PROXY VOTING, AND COMMON STOCK REGISTRATION AND TABULATION OF STOCK PURCHASES; SHAREHOLDER RECORD KEEPING SERVICES; PUBLIC RELATIONS SERVICES; COMMERCIAL INFORMATION AGENCIES, NAMELY, COMMUNICATIONS AND INFORMATION SERVICES REGARDING CORPORATE BUSINESS TRANSACTIONS, FINANCIAL MARKETS AND OTHER BUSINESS MATTERS; BUSINESS DEVELOPMENT CONSULTING SERVICES IN THE AREAS OF MARKET RESEARCH, CREATING STRATEGIES, MATERIALS, BRANDING, ADVERTISING, PROMOTION, SALES, WEBSITE DEVELOPMENT, AND COMMUNICATIONS REGARDING POTENTIAL INVESTMENTS, MEDIA CONSULTING SERVICES IN THE FIELD OF DEVELOPING, CREATING, MONITORING, PURCHASING, DISTRIBUTION, AND IMPLEMENTING COVERAGE ON ALL FORMS OF MEDIA; OPERATION AND MANAGEMENT OF TELEPHONE CALL CENTERS FOR OTHERS; TELEMARKETING SERVICES FOR BUSINESS AND GOVERNMENT ENTITIES; MARKET RESEARCH SERVICES; INFORMATION IN THE FIELD OF GOVERNMENT AFFAIRS; BUSINESS DATA ANALYSIS, NAMELY, ANALYSIS OF SHAREHOLDER AND DEBTHOLDER DATA; HOUSEMARK FOR PROXY VOTING SERVICES FOR OTHERS BY MAIL, GLOBAL COMPUTER INFORMATION NETWORK, AND OTHER ELECTRONIC MEANS, NAMELY, DIAL UP SERVICE, TELEPHONE, ELECTRONIC MAIL, ETC., NAMELY, DISTRIBUTION OF BALLOT INFORMATION AND BALLOTS, VOTE TABULATION, AND DISSEMINATION OF VOTE STATUS INFORMATION (U.S. CLS. 100, 101 AND 102).
FIRST USE 2-7-2008; IN COMMERCE 2-7-2008.

CLASS 36—INSURANCE AND FINANCIAL

FOR FINANCIAL ADMINISTRATION AND MANAGEMENT OF BANKRUPTCY CLAIMS (U.S. CLS. 100, 101 AND 102).
FIRST USE 10-2-2009; IN COMMERCE 10-2-2009.

CLASS 38—COMMUNICATION

FOR PROVIDING MULTIPLE USER ACCESS TO A GLOBAL COMPUTER NETWORK; PROVIDING CO-LOCATION SERVICES FOR VOICE, VIDEO AND DATA COMMUNICATIONS APPLICATIONS; BROADCASTING AND DELIVERY OF AUDIO, VIDEO, AND MULTIMEDIA CONTENT BY MEANS OF WIRELESS COMMUNICATION, THE INTERNET, ELECTRONIC COMMUNICATIONS NETWORKS, AND COMPUTER NETWORKS; PROVIDING MULTIPLE USER ACCESS TO A GLOBAL COMPUTER NETWORK VIA WIRELESS PROTOCOLS; WIRELESS INTERNET SERVICES, NAMELY, PROVIDING WIRELESS PUBLIC INTERNET ACCESS (U.S. CLS. 100, 101 AND 104).
FIRST USE 10-4-2009; IN COMMERCE 10-4-2009.

CLASS 39—TRANSPORTATION AND STORAGE

FOR PROVIDING TO THIRD PARTIES DATA STORAGE FACILITIES, NAMELY, VIRTUAL AND NON-VIRTUAL APPLICATION SERVERS, WEB SERVERS, FILE SERVERS, CO-LOCATION SERVERS, LOAD BALANCING SERVERS, REDUNDANCY SERVERS, MEDIA SERVERS, AND DATABASE SERVERS OF VARIABLE CAPACITY (U.S. CLS. 100 AND 105).
FIRST USE 10-4-2009; IN COMMERCE 10-4-2009.

CLASS 42—SCIENTIFIC AND COMPUTER SERVICES

FOR PROVIDING TO THIRD PARTIES COMPUTING FACILITIES, NAMELY, VIRTUAL AND NON-VIRTUAL APPLICATION SERVERS, WEB SERVERS, FILE SERVERS, CO-LOCATION SERVERS, LOAD BALANCING SERVERS, REDUNDANCY SERVERS, MEDIA SERVERS, AND DATABASE SERVERS OF VARIABLE CAPACITY (U.S. CLS. 100 AND 101).
FIRST USE 10-4-2009; IN COMMERCE 10-4-2009.

4,118,972. SUUNTO OY, VANTAA, FINLAND. SN 77-883,073. PUB. 5-25-2010, FILED 12-1-2009.

WINNING MOVES

THE MARK CONSISTS OF STANDARD CHARACTERS WITHOUT CLAIM TO ANY PARTICULAR FONT, STYLE, SIZE, OR COLOR.

CLASS 9—ELECTRICAL AND SCIENTIFIC APPARATUS

FOR COMPASSES, CLINOMETERS; DEPTH GAUGES, NAMELY, UNDER WATER DEPTH GAUGES; AND PRESSURE GAUGES FOR USE IN DIVING, DIVE TIME MEASURING DEVICES, NAMELY, DIVING TIMERS AND SPORTS TIMERS; DIVE COMPUTERS, COMPUTER PROGRAMS FOR PROCESSING DIVING DATA; TACHOMETERS, ODOMETERS, SPEED METERS, PEDOMETERS, GLOBAL POSITIONING SYSTEM RECEIVERS, ALTIMETERS, BAROMETRIC ALTIMETERS, BAROMETERS, THERMOMETERS, COMPUTERS AND COMPUTER PROGRAMS FOR RECORDING, TRACKING AND MANIPULATING DATA FROM SPORTS OR OUTDOOR ACTIVITIES, NAMELY, DATABASE MANAGEMENT, SPREADSHEETS, AND FIELD SPECIFIC DATA MANAGEMENT ALL USED IN RELATION WITH SPORTS OR OUTDOOR ACTIVITIES (U.S. CLS. 21, 23, 26, 36 AND 38).
FIRST USE 9-1-2011; IN COMMERCE 9-1-2011.

4,118,971. VISI INCORPORATED, EDEN PRAIRIE, MN. SN 77-882,501. PUB. 11-23-2010, FILED 11-30-2009.

CLOUD DONE RIGHT

THE MARK CONSISTS OF STANDARD CHARACTERS WITHOUT CLAIM TO ANY PARTICULAR FONT, STYLE, SIZE, OR COLOR.
NO CLAIM IS MADE TO THE EXCLUSIVE RIGHT TO USE "CLOUD", APART FROM THE MARK AS SHOWN.

CLASS 14—JEWELRY

FOR DIVE WATCHES FEATURING DIVE TIMING FUNCTIONS, SPORTS WATCHES FEATURING HEART RATE MONITORING FUNCTIONS (U.S. CLS. 2, 27, 28 AND 50).

FIRST USE 9-1-2011; IN COMMERCE 9-1-2011.

4,118,973. SUUNTO OY, VANTAA, FINLAND. SN 77-883,075. PUB. 5-25-2010, FILED 12-1-2009.

THRILLING MOVES

THE MARK CONSISTS OF STANDARD CHARACTERS WITHOUT CLAIM TO ANY PARTICULAR FONT, STYLE, SIZE, OR COLOR.

CLASS 9—ELECTRICAL AND SCIENTIFIC APPARATUS

FOR COMPASSES, CLINOMETERS; DEPTH GAUGES, NAMELY, UNDER WATER DEPTH GAUGES; AND PRESSURE GAUGES FOR USE IN DIVING, DIVE TIME MEASURING DEVICES, NAMELY, DIVING TIMERS AND SPORTS TIMERS; DIVE COMPUTERS, COMPUTER PROGRAMS FOR PROCESSING DIVING DATA; TACHOMETERS, ODOMETERS, SPEED METERS, PEDOMETERS, GLOBAL POSITIONING SYSTEM RECEIVERS, ALTIMETERS, BAROMETRIC ALTIMETERS, BAROMETERS, THERMOMETERS, COMPUTERS AND COMPUTER PROGRAMS FOR RECORDING, TRACKING AND MANIPULATING DATA FROM SPORTS OR OUTDOOR ACTIVITIES, NAMELY, DATABASE MANAGEMENT, SPREADSHEETS, AND FIELD SPECIFIC DATA MANAGEMENT ALL USED IN RELATION WITH SPORTS OR OUTDOOR ACTIVITIES (U.S. CLS. 21, 23, 26, 36 AND 38).

FIRST USE 9-1-2011; IN COMMERCE 9-1-2011.

CLASS 14—JEWELRY

FOR DIVE WATCHES FEATURING DIVE TIMING FUNCTIONS, SPORTS WATCHES FEATURING HEART RATE MONITORING FUNCTIONS (U.S. CLS. 2, 27, 28 AND 50).

FIRST USE 9-1-2011; IN COMMERCE 9-1-2011.

4,118,974. QUEST METAL SOLUTIONS, INC., FORT WORTH, TX. SN 77-883,319. PUB. 11-23-2010, FILED 12-1-2009.

GOT DUCT?

THE MARK CONSISTS OF STANDARD CHARACTERS WITHOUT CLAIM TO ANY PARTICULAR FONT, STYLE, SIZE, OR COLOR.

CLASS 37—CONSTRUCTION AND REPAIR

FOR COMMERCIAL, INDUSTRIAL, AND RESIDENTIAL HVAC CONTRACTOR SERVICES, NAMELY, INSTALLATION, REPLACEMENT, AND REPAIR OF HEATING, VENTILATING AND AIR CONDITIONING APPARATUS; INSTALLATION OF DUST COLLECTING AND EXHAUST SYSTEMS; AIR DUCT CLEANING SERVICES; APPLICATION OF COATINGS AND SEALERS; APPLYING DECORATIVE COATINGS TO METAL BY MEANS OF GALVANIZATION; HVAC METAL CONTRACTOR SERVICES, NAMELY, INSTALLATION OF EQUIPMENT PADS, EQUIPMENT RAILS, CUSTOM DRAIN PANS, ROOF CURBS, METAL TRASH SHOOT, METAL GATES, HANDRAILS, METAL STAIRCASES, CUSTOM GUTTERS, CATWALKS, GRATINGS, BUILDING ACCESS LADDERS AND FIRE ESCAPES, CUSTOM BARBECUE AND SMOKE PITS, GREASE DUCT AND VENT HOODS; REMANUFACTURE AND REPAIR OF HVAC METAL TO THE ORDER AND/OR SPECIFICATION OF OTHERS, DUCT WORK SERVICES, NAMELY, INSTALLATION OF FIBERGLASS DUCTS AND POLYPROPYLENE DUCTS (U.S. CLS. 100, 103 AND 106).

FIRST USE 3-1-2005; IN COMMERCE 3-1-2005.

CLASS 40—MATERIAL TREATMENT

FOR CUSTOM FABRICATION OF DUST COLLECTING AND EXHAUST SYSTEMS, BUILDING CONSTRUCTION CONSULTATION REGARDING CUSTOM CONSTRUCTION HVAC METAL WORK TO THE ORDER AND SPECIFICATION OF OTHERS; CUSTOM FABRICATION OF EQUIPMENT PADS, EQUIPMENT RAILS, CUSTOM DRAIN PANS, ROOF CURBS, METAL TRASH SHOOT, METAL GATS, HANDRAILS, METAL STAIRCASES, CUSTOM GUTTERS, CATWALKS, GRATINGS, BUILDING ACCESS LADDERS AND FIRE ESCAPES, CUSTOM BARBECUE AND SMOKE PITS, GREASE DUCT AND VENT HOODS, FIBERGLASS DUCTS AND POLYPROPYLENE DUCTS; WELDING SERVICES AND PRECISION CUTTING OF STEEL, STAINLESS AND ALUMINUM METAL (U.S. CLS. 100, 103 AND 106).

FIRST USE 3-1-2005; IN COMMERCE 3-1-2005.

CLASS 42—SCIENTIFIC AND COMPUTER SERVICES

FOR BUILDING CONSTRUCTION CONSULTATION AND PLANNING SERVICES, NAMELY, THE DESIGN OF HVAC METAL WORK TO THE ORDER AND/OR SPECIFICATION OF OTHERS; DESIGN OF DUST COLLECTING AND EXHAUST SYSTEMS FOR OTHERS, BUILDING CONSTRUCTION DESIGN CONSULTATION REGARDING THE DESIGN OF HVAC METAL WORK FOR OTHERS; HVAC METAL CONTRACT SERVICES, NAMELY, DESIGN OF EQUIPMENT PADS, EQUIPMENT RAILS, CUSTOM DRAIN PANS, ROOF CURBS, METAL TRASH SHOOT, METAL GATS, HANDRAILS, METAL STAIRCASES, CUSTOM GUTTERS, CATWALKS, GRATINGS, BUILDING ACCESS LADDERS AND FIRE ESCAPES, CUSTOM BARBECUE AND SMOKE PITS, GREASE DUCT AND VENT HOODS, FIBERGLASS DUCTS AND POLYPROPYLENE DUCTS (U.S. CLS. 100 AND 101).

FIRST USE 3-1-2005; IN COMMERCE 3-1-2005.

4,118,976. SOCIETE DES PRODUITS NESTLE S.A., 1800 VEVEY, SWITZERLAND. SN 77-884,164. PUB. 4-27-2010, FILED 12-2-2009.

CRAMP-CRUSHING

THE MARK CONSISTS OF STANDARD CHARACTERS WITHOUT CLAIM TO ANY PARTICULAR FONT, STYLE,

SIZE, OR COLOR.

CLASS 30—STAPLE FOODS

FOR NUTRITIONAL SUPPLEMENTS SOLD AS AN INTEGRAL PART OF CEREAL-BASED ENERGY BARS AND GLUCOSE-BASED ENERGY GELS (U.S. CL. 46).
FIRST USE 4-1-2010; IN COMMERCE 4-1-2010.

CLASS 32—LIGHT BEVERAGES

FOR NUTRITIONAL SUPPLEMENTS SOLD AS AN INTEGRAL PART OF ENERGY DRINKS (U.S. CLS. 45, 46 AND 48).
FIRST USE 4-1-2010; IN COMMERCE 4-1-2010.

4,118,977. THE LUCCI CORP., PETERBOROUGH, NH. SN 77-885,557. PUB. 12-7-2010, FILED 12-3-2009.

INVISION CAMO

THE MARK CONSISTS OF STANDARD CHARACTERS WITHOUT CLAIM TO ANY PARTICULAR FONT, STYLE, SIZE, OR COLOR.

NO CLAIM IS MADE TO THE EXCLUSIVE RIGHT TO USE "CAMO", APART FROM THE MARK AS SHOWN.

CLASS 18—LEATHER GOODS

FOR BACKPACKS (U.S. CLS. 1, 2, 3, 22 AND 41).
FIRST USE 1-0-2010; IN COMMERCE 1-0-2010.

CLASS 20—FURNITURE AND ARTICLES NOT OTHERWISE CLASSIFIED

FOR CUSHIONS (U.S. CLS. 2, 13, 22, 25, 32 AND 50).
FIRST USE 1-0-2010; IN COMMERCE 1-0-2010.

4,118,981. SUUNTO OY, VANTAA, FINLAND. SN 77-896,000. PUB. 5-25-2010, FILED 12-17-2009.

INSPIRING MOVES

THE MARK CONSISTS OF STANDARD CHARACTERS WITHOUT CLAIM TO ANY PARTICULAR FONT, STYLE, SIZE, OR COLOR.

CLASS 9—ELECTRICAL AND SCIENTIFIC APPARATUS

FOR COMPASSES, CLINOMETERS; DEPTH GAUGES, NAMELY, UNDER WATER DEPTH GAUGES; AND PRESSURE GAUGES FOR USE IN DIVING, DIVE TIME MEASURING DEVICES, NAMELY, DIVING TIMERS AND SPORTS TIMERS; DIVE COMPUTERS, COMPUTER PROGRAMS FOR PROCESSING DIVING DATA; TACHOMETERS, ODOMETERS, SPEED METERS, PEDOMETERS, GLOBAL POSITIONING SYSTEM RECEIVERS, ALTIMETERS, BAROMETRIC ALTIMETERS, BAROMETERS, THERMOMETERS, COMPUTERS AND COMPUTER PROGRAMS FOR RECORDING, TRACKING AND MANIPULATING DATA FROM SPORTS OR OUTDOOR ACTIVITIES, NAMELY, DATABASE MANAGEMENT, SPREADSHEETS, AND FIELD SPECIFIC DATA MANAGEMENT ALL USED IN RELATION WITH SPORTS OR OUTDOOR ACTIVITIES (U.S. CLS. 21, 23, 26, 36 AND 38).

FIRST USE 9-1-2011; IN COMMERCE 9-1-2011.

CLASS 14—JEWELRY

FOR DIVE WATCHES FEATURING DIVE TIMING FUNCTIONS, SPORTS WATCHES FEATURING HEART RATE MONITORING FUNCTIONS (U.S. CLS. 2, 27, 28 AND 50).

FIRST USE 9-1-2011; IN COMMERCE 9-1-2011.

4,118,990. BOOZ ALLEN HAMILTON INC., MCLEAN, VA. SN 77-907,555. PUB. 11-23-2010, FILED 1-8-2010.

EARNED READINESS

THE MARK CONSISTS OF STANDARD CHARACTERS WITHOUT CLAIM TO ANY PARTICULAR FONT, STYLE, SIZE, OR COLOR.

NO CLAIM IS MADE TO THE EXCLUSIVE RIGHT TO USE "READINESS", APART FROM THE MARK AS SHOWN.

CLASS 35—ADVERTISING AND BUSINESS

FOR COMMERCIAL CONSULTANCY WITH INDUSTRY REGARDING MILITARY READINESS LEVELS (U.S. CLS. 100, 101 AND 102).
FIRST USE 9-0-2011; IN COMMERCE 9-0-2011.

CLASS 45—PERSONAL AND LEGAL SERVICES

FOR MILITARY STRATEGY CONSULTING SERVICES REGARDING READINESS LEVELS (U.S. CLS. 100 AND 101).
FIRST USE 9-0-2011; IN COMMERCE 9-0-2011.

4,118,994. VISI INCORPORATED, EDEN PRAIRIE, MN. SN 77-910,197. PUB. 11-23-2010, FILED 1-12-2010.

INFRASTRUCTURE. SIMPLIFIED.

THE MARK CONSISTS OF STANDARD CHARACTERS WITHOUT CLAIM TO ANY PARTICULAR FONT, STYLE, SIZE, OR COLOR.

NO CLAIM IS MADE TO THE EXCLUSIVE RIGHT TO USE "INFRASTRUCTURE", APART FROM THE MARK AS SHOWN.

CLASS 38—COMMUNICATION

FOR PROVIDING MULTIPLE USER ACCESS TO A GLOBAL COMPUTER NETWORK; PROVIDING CO-LOCATION SERVICES FOR VOICE, VIDEO AND DATA COMMUNICATIONS APPLICATIONS; BROADCASTING AND DELIVERY OF AUDIO, VIDEO, AND MULTI-MEDIA CONTENT BY MEANS OF WIRELESS COMMUNICATION, THE INTERNET, ELECTRONIC COMMUNICATIONS NETWORKS, AND COMPUTER NETWORKS; PROVIDING MULTIPLE USER ACCESS TO A GLOBAL COMPUTER NETWORK VIA WIRELESS PROTOCOLS; WIRELESS INTERNET SERVICES, NAMELY, PROVIDING WIRELESS PUBLIC INTERNET ACCESS (U.S. CLS. 100, 101 AND 104).
FIRST USE 1-12-2010; IN COMMERCE 1-12-2010.

CLASS 39—TRANSPORTATION AND STORAGE

FOR PROVIDING TO THIRD PARTIES DATA STORAGE FACILITIES, NAMELY, VIRTUAL AND NON-VIRTUAL APPLICATION SERVERS, WEB SERVERS, FILE SERVERS, CO-LOCATION SERVERS, LOAD BALANCING SERVERS, REDUNDANCY SERVERS, MEDIA SERVERS, AND DATABASE SERVERS OF VARIABLE CAPACITY (U.S. CLS. 100 AND 105).
FIRST USE 1-12-2010; IN COMMERCE 1-12-2010.

CLASS 42—SCIENTIFIC AND COMPUTER SERVICES

FOR PROVIDING TO THIRD PARTIES COMPUTING FACILITIES, NAMELY, VIRTUAL AND NON-VIRTUAL APPLICATION SERVERS, WEB SERVERS, FILE SERVERS, CO-LOCATION SERVERS, LOAD BALANCING SERVERS, REDUNDANCY SERVERS, MEDIA SERVERS, AND DATABASE SERVERS OF VARIABLE CAPACITY (U.S. CLS. 100 AND 101).
FIRST USE 1-12-2010; IN COMMERCE 1-12-2010.

4,118,999. BOSTON SCOTT CORPORATION, WAKEFIELD, MA. SN 77-911,317. PUB. 12-7-2010, FILED 1-13-2010.

pAGUAMEDICINA

THE MARK CONSISTS OF STANDARD CHARACTERS WITHOUT CLAIM TO ANY PARTICULAR FONT, STYLE, SIZE, OR COLOR.

THE ENGLISH TRANSLATION OF "AGUAMEDICINA" IN THE MARK IS "WATER MEDICINE".

CLASS 5—PHARMACEUTICALS

FOR HYDROGELS FOR MEDICAL PURPOSES (U.S. CLS. 6, 18, 44, 46, 51 AND 52).
FIRST USE 5-28-2010; IN COMMERCE 5-28-2010.

CLASS 10—MEDICAL APPARATUS

FOR MEDICAL STENTS, AND CATHETERS COMPOSED OF HYDROGEL; MEDICAL STENTS, AND CATHETERS COMPOSED OF HYDROPHILIC MATERIALS; MEDICAL INSTRUMENTS AND APPARATUS, NAMELY, DELIVERY APPARATUS FOR HYDROGEL; COATINGS SOLD AS AN INTEGRAL COMPONENT OF MEDICAL STENTS AND OTHER IMPLANTABLE MEDICAL DEVICES (U.S. CLS. 26, 39 AND 44).
FIRST USE 5-28-2010; IN COMMERCE 5-28-2010.

4,119,004. BOEHRINGER INGELHEIM PHARMACEUTICALS, INC., RIDGEFIELD, CT. SN 77-916,674. PUB. 4-19-2011, FILED 1-21-2010.

DRIVE4COPD

THE MARK CONSISTS OF STANDARD CHARACTERS WITHOUT CLAIM TO ANY PARTICULAR FONT, STYLE, SIZE, OR COLOR.

CLASS 14—JEWELRY

FOR ORNAMENTAL PINS (U.S. CLS. 2, 27, 28 AND 50).
FIRST USE 2-0-2010; IN COMMERCE 2-0-2010.

CLASS 16—PAPER GOODS AND PRINTED MATTER

FOR PRINTED MEDIA, NAMELY, BROCHURES, PAMPHLETS, AND POSTERS ABOUT COPD (U.S. CLS. 2, 5, 22, 23, 29, 37, 38 AND 50).
FIRST USE 2-0-2010; IN COMMERCE 2-0-2010.

CLASS 25—CLOTHING

FOR APPAREL, NAMELY, T-SHIRTS, SHIRTS, PANTS, JUMPSUITS, HATS (U.S. CLS. 22 AND 39).
FIRST USE 2-0-2010; IN COMMERCE 2-0-2010.

CLASS 44—MEDICAL, BEAUTY AND AGRICULTURAL SERVICES

FOR PROVIDING MEDICAL INFORMATION RELATED TO COPD AWARENESS VIA BROCHURES, PAMPHLETS, SIGNAGE, BILLBOARDS, TELEVISION, INTERNET, NEWSPAPERS AND MAGAZINES (U.S. CLS. 100 AND 101).
FIRST USE 2-0-2010; IN COMMERCE 2-0-2010.

4,119,007. BOEHRINGER INGELHEIM PHARMACEUTICALS, INC., RIDGEFIELD, CT. SN 77-920,050. PUB. 4-19-2011, FILED 1-26-2010.



THE COLOR(S) ORANGE AND BLUE IS/ARE CLAIMED AS A FEATURE OF THE MARK.

THE MARK CONSISTS OF A PINWHEEL DESIGN WITH ALTERNATING ORANGE AND BLUE TRIANGLES.

CLASS 16—PAPER GOODS AND PRINTED MATTER

FOR PRINTED MEDIA, NAMELY, BROCHURES, PAMPHLETS, STICKERS, WINDOW AND AUTOMOTIVE DECALS AND POSTERS ABOUT COPD (U.S. CLS. 2, 5, 22, 23, 29, 37, 38 AND 50).
FIRST USE 2-0-2010; IN COMMERCE 2-0-2010.

CLASS 25—CLOTHING

FOR APPAREL, NAMELY, T-SHIRTS, SHIRTS, PANTS, JUMPSUITS, HATS (U.S. CLS. 22 AND 39).
FIRST USE 2-0-2010; IN COMMERCE 2-0-2010.

CLASS 28—TOYS AND SPORTING GOODS

FOR PLAYTHINGS, NAMELY, TOY CARS (U.S. CLS. 22, 23, 38 AND 50).
FIRST USE 2-0-2010; IN COMMERCE 2-0-2010.

CLASS 44—MEDICAL, BEAUTY AND AGRICULTURAL SERVICES

FOR PROVIDING MEDICAL INFORMATION RELATED TO COPD AWARENESS VIA BROCHURES, PAMPHLETS, SIGNAGE, BILLBOARDS, TELEVISION, INTERNET, NEWSPAPERS AND MAGAZINES (U.S. CLS. 100 AND 101).
FIRST USE 2-0-2010; IN COMMERCE 2-0-2010.

4,119,008. BOEHRINGER INGELHEIM PHARMACEUTICALS, INC., RIDGEFIELD, CT. SN 77-920,064. PUB. 4-19-2011, FILED 1-26-2010.



THE COLOR(S) BLUE AND ORANGE IS/ARE CLAIMED AS A FEATURE OF THE MARK.

THE MARK CONSISTS OF A PINWHEEL DESIGN WITH

ALTERNATING ORANGE AND BLUE TRIANGLES ABOVE THE WORDING "DRIVE4COPD", WITH THE TERMS "DRIVE" AND "COPD" IN ORANGE AND THE "4" IN BLUE.

CLASS 16—PAPER GOODS AND PRINTED MATTER

FOR PRINTED MEDIA, NAMELY, BROCHURES, PAMPHLETS, STICKERS, WINDOW AND AUTOMOTIVE DECALS AND POSTERS ABOUT COPD (U.S. CLS. 2, 5, 22, 23, 29, 37, 38 AND 50).
FIRST USE 2-0-2010; IN COMMERCE 2-0-2010.

CLASS 25—CLOTHING

FOR APPAREL, NAMELY, T-SHIRTS, SHIRTS, PANTS, JUMPSUITS, HATS (U.S. CLS. 22 AND 39).
FIRST USE 2-0-2010; IN COMMERCE 2-0-2010.

CLASS 28—TOYS AND SPORTING GOODS

FOR PLAYTHINGS, NAMELY, TOY CARS (U.S. CLS. 22, 23, 38 AND 50).
FIRST USE 2-0-2010; IN COMMERCE 2-0-2010.

CLASS 44—MEDICAL, BEAUTY AND AGRICULTURAL SERVICES

FOR PROVIDING MEDICAL INFORMATION RELATED TO COPD AWARENESS VIA BROCHURES, PAMPHLETS, SIGNAGE, BILLBOARDS, TELEVISION, INTERNET, NEWSPAPERS AND MAGAZINES (U.S. CLS. 100 AND 101).
FIRST USE 2-0-2010; IN COMMERCE 2-0-2010.

4,119,009. BOEHRINGER INGELHEIM PHARMACEUTICALS, INC., RIDGEFIELD, CT. SN 77-920,108. PUB. 4-19-2011, FILED 1-26-2010.



THE COLOR(S) ORANGE AND BLUE IS/ARE CLAIMED AS A FEATURE OF THE MARK.

THE MARK CONSISTS OF A PINWHEEL DESIGN WITH ALTERNATING ORANGE AND BLUE TRIANGLES, CENTERED OVER THE WORDS: "DRIVE4COPD", WHERE THE WORDS: "DRIVE" AND "COPD" ARE ORANGE AND THE NUMBER: "4" IS BLUE, UNDERNEATH WHICH IS A CENTERED BLUE SOLID LINE AND CENTERED BELOW THE LINE ARE THE WORDS: "TAKE ACTION TODAY. BREATHE BETTER TOMORROW." WHERE THE TERMS "TAKE ACTION" AND "BREATHE BETTER" ARE IN BLUE, AND THE TERMS "TODAY." AND "TOMORROW." ARE IN ORANGE.

CLASS 16—PAPER GOODS AND PRINTED MATTER

FOR PRINTED MEDIA, NAMELY, BROCHURES, PAMPHLETS, STICKERS, WINDOW AND AUTOMOTIVE DECALS AND POSTERS ABOUT COPD (U.S. CLS. 2, 5, 22, 23, 29, 37, 38 AND 50).
FIRST USE 2-0-2010; IN COMMERCE 2-0-2010.

CLASS 25—CLOTHING

FOR APPAREL, NAMELY, T-SHIRTS, SHIRTS, PANTS, JUMPSUITS, HATS (U.S. CLS. 22 AND 39).
FIRST USE 2-0-2010; IN COMMERCE 2-0-2010.

CLASS 28—TOYS AND SPORTING GOODS

FOR PLAYTHINGS, NAMELY, TOYS CARS (U.S. CLS. 22, 23, 38 AND 50).
FIRST USE 2-0-2010; IN COMMERCE 2-0-2010.

CLASS 44—MEDICAL, BEAUTY AND AGRICULTURAL SERVICES

FOR PROVIDING MEDICAL INFORMATION RELATED TO COPD AWARENESS VIA BROCHURES, PAMPHLETS, SIGNAGE, BILLBOARDS, TELEVISION, INTERNET, NEWSPAPERS AND MAGAZINES (U.S. CLS. 100 AND 101).
FIRST USE 2-0-2010; IN COMMERCE 2-0-2010.

CLASS 18—LEATHER GOODS

FOR BACKPACKS, KNAPSACKS, DAYPACKS, FANNY PACKS, TOTE BAGS, DUFFEL BAGS, OVERNIGHT BAGS, ATHLETIC BAGS, CARRY-ON BAGS AND LUGGAGE, WALLETS, COIN PURSES, KEY CASES (U.S. CLS. 1, 2, 3, 22 AND 41).
FIRST USE 8-0-2008; IN COMMERCE 8-0-2008.

CLASS 28—TOYS AND SPORTING GOODS

FOR SPORTS EQUIPMENT FOR SNOWBOARDING, NAMELY, SNOWBOARD GLOVES; BAGS FOR SNOWBOARDS; BAGS FOR SURFBOARDS; SURFBOARD LEASHES; SNOWBOARD WAX; SURFBOARD WAX (U.S. CLS. 22, 23, 38 AND 50).
FIRST USE 8-0-2011; IN COMMERCE 8-0-2011.

4,119,011. NEFF, SHAUN M., CAMARILLO, CA. AND NEFF, JOE W., CAMARILLO, CA. SN 77-921,643. PUB. 6-22-2010, FILED 1-27-2010.



OWNER OF U.S. REG. NO. 3,569,666.

THE MARK CONSISTS OF A ROUND SMILING FACE SHOWING AN EXPOSED TONGUE, ROUND EYES, AN UP SLANTED SLIT NOSE AND SWEEPING HAIR WITH THE LETTERS "NEFF" IN STYLIZED LETTERING BELOW THE FACE.

CLASS 9—ELECTRICAL AND SCIENTIFIC APPARATUS

FOR EYEWEAR, EYEGLASSES, SUNGLASSES; FRAMES, LENSES AND PROTECTIVE CASES FOR EYEWEAR, EYEGLASSES, SUNGLASSES AND GOGGLES; SNOW GOGGLES; SPORT GOGGLES FOR USE IN SNOWBOARDING; SKI GLASSES; ANTI-GLARE GLASSES; EYEWEAR ACCESSORIES, NAMELY, STRAPS, NECK CORDS, CHAINS AND HEAD STRAPS; HEADPHONES; EARPHONES; KNIT COVERS FOR HEADPHONES; PROTECTIVE CARRYING CASES FOR CELL PHONES AND PERSONAL DIGITAL ASSISTANTS (U.S. CLS. 21, 23, 26, 36 AND 38).

FIRST USE 8-0-2008; IN COMMERCE 8-0-2008.

CLASS 14—JEWELRY

FOR JEWELRY, NAMELY, BRACELETS, RINGS, NECKLACES, PINS, AMULETS, BROOCHES, CHAINS AND CHARMS; HOROLOGICAL AND CHRONOMETRIC INSTRUMENTS, NAMELY, WATCHES, WRIST WATCHES AND CLOCKS; WATCH BANDS; WATCH STRAPS; WATCH CHAINS; CASES FOR WATCHES; CASES FOR CLOCKS (U.S. CLS. 2, 27, 28 AND 50).

FIRST USE 8-0-2010; IN COMMERCE 8-0-2010.

4,119,027. THERE GOES MY HERO, INC., BEL AIR, MD. SN 77-931,387. PUB. 12-21-2010, FILED 2-9-2010.

THERE GOES MY HERO

THE MARK CONSISTS OF STANDARD CHARACTERS WITHOUT CLAIM TO ANY PARTICULAR FONT, STYLE, SIZE, OR COLOR.

CLASS 35—ADVERTISING AND BUSINESS

FOR PROMOTING PUBLIC AWARENESS OF PUBLIC HEALTH IN THE FIELDS OF CANCER, CANCER RESEARCH, DELIVERY OF PATIENT CARE, BONE MARROW DONOR REGISTRY, CANCER RECOVERY AND SURVIVAL BY DEVELOPING AND CARRYING OUT COMMUNITY AND NATIONAL PROGRAMS, BY ARRANGING FOR SPONSORS TO AFFILIATE WITH COMMUNITY AND NATIONAL PROGRAMS AND BY PROVIDING AN INFORMATIONAL WEBSITE; CHARITABLE SERVICES, NAMELY, ORGANIZING AND CONDUCTING VOLUNTEER PROGRAMS AND COMMUNITY SERVICE PROJECTS (U.S. CLS. 100, 101 AND 102).

FIRST USE 7-0-2009; IN COMMERCE 7-0-2009.

CLASS 36—INSURANCE AND FINANCIAL

FOR FINANCIAL SPONSORSHIP OF COMMUNITY AND NATIONAL PROGRAMS IN THE FIELDS OF CANCER, CANCER RESEARCH, DELIVERY OF PATIENT CARE, BONE MARROW DONOR REGISTRY, CANCER RECOVERY AND SURVIVAL; CHARITABLE FUNDRAISING SERVICES; PROVIDING RESEARCH GRANTS TO ORGANIZATIONS IN THE FIELDS OF PUBLIC HEALTH, CANCER, BONE MARROW DONOR REGISTRATION, CANCER RECOVERY AND SURVIVAL; PROVIDING A WEB SITE FEATURING INFORMATION, COMPREHENSIVE CONTENT AND PERSONAL STORIES CONCERNING FINANCES IN THE FIELDS OF CANCER, BONE MARROW DONATION, BONE MARROW TRANSPLANT, CANCER RECOVERY AND SURVIVAL (U.S. CLS. 100, 101 AND 102).

FIRST USE 7-0-2009; IN COMMERCE 7-0-2009.

4,119,028. THERE GOES MY HERO, INC., BEL AIR, MD. SN 77-931,447. PUB. 12-21-2010, FILED 2-9-2010.



THE COLOR(S) RED AND BLACK IS/ARE CLAIMED AS A FEATURE OF THE MARK.

THE MARK CONSISTS OF A HUMAN DEPICTED FLYING WITH A CAPE, FORMED BY A LARGE RED CURVED TRIANGLE, A SMALL BLACK CURVED TRIANGLE AND A BLACK CIRCLE. THE WORDING "THERE GOES MY HERO" APPEARS IN BLACK UNDER THE DESIGN ELEMENT.

CLASS 35—ADVERTISING AND BUSINESS

FOR PROMOTING PUBLIC AWARENESS OF PUBLIC HEALTH IN THE FIELDS OF CANCER, CANCER RESEARCH, DELIVERY OF PATIENT CARE, BONE MARROW DONOR REGISTRY, CANCER RECOVERY AND SURVIVAL BY DEVELOPING AND CARRYING OUT COMMUNITY AND NATIONAL PROGRAMS, BY ARRANGING FOR SPONSORS TO AFFILIATE WITH COMMUNITY AND NATIONAL PROGRAMS AND BY PROVIDING AN INFORMATIONAL WEBSITE; CHARITABLE SERVICES, NAMELY, ORGANIZING AND CONDUCTING VOLUNTEER PROGRAMS AND COMMUNITY SERVICE PROJECTS (U.S. CLS. 100, 101 AND 102).

FIRST USE 7-0-2009; IN COMMERCE 7-0-2009.

CLASS 36—INSURANCE AND FINANCIAL

FOR FINANCIAL SPONSORSHIP OF COMMUNITY AND NATIONAL PROGRAMS IN THE FIELDS OF CANCER, CANCER RESEARCH, DELIVERY OF PATIENT CARE, BONE MARROW DONOR REGISTRY, CANCER RECOVERY AND SURVIVAL; CHARITABLE FUNDRAISING SERVICES; PROVIDING RESEARCH GRANTS TO ORGANIZATIONS IN THE FIELDS OF PUBLIC HEALTH, CANCER, BONE MARROW DONOR REGISTRATION, CANCER RECOVERY AND SURVIVAL; PROVIDING A WEB SITE FEATURING INFORMATION, COMPREHENSIVE CONTENT AND PERSONAL STORIES CONCERNING FINANCES IN THE FIELDS OF CANCER, BONE MARROW DONATION, BONE MARROW TRANSPLANT, CANCER RECOVERY AND SURVIVAL (U.S. CLS. 100, 101 AND 102).

FIRST USE 7-0-2009; IN COMMERCE 7-0-2009.

4,119,033. QUORA, INC., PALO ALTO, CA. SN 77-935,145. PUB. 7-27-2010, FILED 2-12-2010.

QUORA

THE MARK CONSISTS OF STANDARD CHARACTERS WITHOUT CLAIM TO ANY PARTICULAR FONT, STYLE, SIZE, OR COLOR.

CLASS 42—SCIENTIFIC AND COMPUTER SERVICES

FOR COMPUTER SERVICES, NAMELY, PROVIDING CUSTOMIZED ONLINE WEB PAGES FEATURING USER-DEFINED INFORMATION; COMPUTER SERVICES, NAMELY, PROVIDING A WEBPAGE FOR USERS TO ASK AND ANSWER QUESTIONS ON A VARIETY OF TOPICS OF GENERAL INTEREST, PROVIDING SEARCH ENGINES FOR OBTAINING INFORMATION REQUESTED BY USERS ON A GLOBAL COMPUTER NETWORK, PROVIDING CUSTOMIZED SEARCHING OF A WEBPAGE TO LOCATE SPECIFIC INFORMATION REQUESTED BY USERS, CREATING AN ON-LINE COMMUNITY FOR REGISTERED USERS TO PARTICIPATE IN DISCUSSIONS, GET FEEDBACK FROM THEIR PEERS, FORM VIRTUAL COMMUNITIES, AND ENGAGE IN SOCIAL NETWORKING; APPLICATION SERVICE PROVIDER FEATURING APPLICATION PROGRAMMING INTERFACE (API) SOFTWARE FOR USE IN BUILDING SOFTWARE APPLICATIONS (U.S. CLS. 100 AND 101).

FIRST USE 6-21-2010; IN COMMERCE 6-21-2010.

CLASS 45—PERSONAL AND LEGAL SERVICES

FOR ON-LINE SOCIAL NETWORKING SERVICES (U.S. CLS. 100 AND 101).

FIRST USE 6-21-2010; IN COMMERCE 6-21-2010.

4,119,034. THERE GOES MY HERO, INC., BEL AIR, MD. SN 77-935,894. PUB. 12-21-2010, FILED 2-15-2010.



THE COLOR(S) RED AND BLACK IS/ARE CLAIMED AS A FEATURE OF THE MARK.

THE MARK CONSISTS OF A HUMAN DEPICTED FLYING WITH A CAPE, FORMED BY A LARGE RED CURVED TRIANGLE, A SMALL BLACK CURVED TRIANGLE AND A BLACK CIRCLE.

CLASS 35—ADVERTISING AND BUSINESS

FOR PROMOTING PUBLIC AWARENESS OF PUBLIC HEALTH IN THE FIELDS OF CANCER, CANCER RESEARCH, DELIVERY OF PATIENT CARE, BONE MARROW DONOR REGISTRY, CANCER RECOVERY AND SURVIVAL BY DEVELOPING AND CARRYING OUT COMMUNITY AND NATIONAL PROGRAMS, BY ARRANGING FOR SPONSORS TO AFFILIATE WITH COMMUNITY AND NATIONAL PROGRAMS AND BY PROVIDING AN INFORMATIONAL WEBSITE; CHARITABLE SERVICES, NAMELY, ORGANIZING AND CONDUCTING VOLUNTEER PROGRAMS AND COMMUNITY SERVICE PROJECTS (U.S. CLS. 100, 101 AND 102).

FIRST USE 7-0-2009; IN COMMERCE 7-0-2009.

CLASS 36—INSURANCE AND FINANCIAL

FOR FINANCIAL SPONSORSHIP OF COMMUNITY AND NATIONAL PROGRAMS IN THE FIELDS OF CANCER, CANCER RESEARCH, DELIVERY OF PATIENT CARE, BONE MARROW DONOR REGISTRY, CANCER RECOVERY AND SURVIVAL; CHARITABLE FUNDRAISING SERVICES; PROVIDING RESEARCH GRANTS TO ORGANIZATIONS IN THE FIELDS OF PUBLIC HEALTH, CANCER, BONE MARROW DONOR REGISTRATION, CANCER RECOVERY AND SURVIVAL; PROVIDING A WEB SITE FEATURING INFORMATION, COMPREHENSIVE CONTENT AND PERSONAL STORIES CONCERNING FINANCES IN THE FIELDS OF CANCER, BONE MARROW DONATION, BONE MARROW TRANSPLANT, CANCER RECOVERY AND SURVIVAL (U.S. CLS. 100, 101 AND 102).
FIRST USE 7-0-2009; IN COMMERCE 7-0-2009.

4,119,035. LIGHTWEDGE, INC., NEWTON, MA. SN 77-937,707. PUB. 1-18-2011, FILED 2-17-2010.

VERSO

THE MARK CONSISTS OF STANDARD CHARACTERS WITHOUT CLAIM TO ANY PARTICULAR FONT, STYLE, SIZE, OR COLOR.

CLASS 9—ELECTRICAL AND SCIENTIFIC APPARATUS

FOR CASES FOR ELECTRONIC BOOK READERS (U.S. CLS. 21, 23, 26, 36 AND 38).
FIRST USE 6-0-2010; IN COMMERCE 6-0-2010.

CLASS 11—ENVIRONMENTAL CONTROL APPARATUS

FOR READING LIGHT (U.S. CLS. 13, 21, 23, 31 AND 34).
FIRST USE 6-0-2010; IN COMMERCE 6-0-2010.

4,119,036. E & M CAPITAL DISTRIBUTORS, LLC, LANDOVER, MD. SN 77-940,713. PUB. 7-13-2010, FILED 2-20-2010.

BUEN PROVECHO

THE MARK CONSISTS OF STANDARD CHARACTERS WITHOUT CLAIM TO ANY PARTICULAR FONT, STYLE, SIZE, OR COLOR.

THE ENGLISH TRANSLATION OF "BUEN PROVECHO" IN THE MARK IS "HAVE A GOOD MEAL".

CLASS 29—MEATS AND PROCESSED FOODS

FOR BAKED BEANS; BANANA CHIPS; BEAN CURD; BEAN DIP; BROTH; CANDIED FRUIT; CANDIED FRUIT SNACKS; CANNED FRUITS; CANNED FRUITS AND VEGETABLES; CANNED OR BOTTLED FRUITS; CANNED OR BOTTLED VEGETABLES; CANNED PORK AND BEANS; CANNED VEGETABLES; CANOLA OIL; CHEESE; CHEESE SPREADS; COCONUT OIL; COCONUT OIL AND FAT; COOKED FRUITS AND VEGETABLES; COOKED VEGETABLES; COOKING OIL; CORN OIL; COTTAGE CHEESE; CREAM CHEESE; CRYSTALLIZED FRUIT; DEHYDRATED FRUIT SNACKS; DIPS; DRIED BEANS; DRIED FRUIT AND VEGETABLES; DRIED FRUIT MIXES; DRIED FRUIT-BASED SNACKS; DRIED FRUITS; DRINKABLE SOUPS; DRINKING YOGURTS; DRINKS BASED ON YOGURT; EDIBLE OILS; EXTRACTS FOR SOUPS; FRESH UNRIPENED CHEESES; FROZEN VEGETABLES; FRUIT AND SOY BASED SNACK FOOD; FRUIT CHIPS; FRUIT CONCENTRATES AND PUREES USED AS INGREDIENTS OF FOODS; FRUIT CONSERVES; FRUIT PASTE; FRUIT PRESERVES; FRUIT PULP; FRUIT PULPS; FRUIT PUREES; FRUIT-BASED SNACK FOOD; FRUIT-BASED SPREADS; JAMS; JAMS AND MARMALADES; JELLIES AND JAMS; JELLIES, JAMS; MARMALADES AND JAMS; MILK-BASED BEVERAGE CONTAINING COFFEE; MOLD-RIPENED CHEESE; MOULD-RIPENED CHEESE; OLIVE OIL; OLIVE OIL; PALM OIL; PEANUT OIL; PICKLED VEGETABLES; POTATO CHIPS; PRESERVED FRUITS; PRESERVED FRUITS AND VEGETABLES; PRESERVED VEGETABLES; PRESERVED VEGETABLES (IN OIL); REFRIED BEANS; RIPENED CHEESE; RIPENED CHEESES; SARDINES; SLICED FRUITS; SLICED VEGETABLES; SNACK DIPS; SNACK FOOD DIPS; SOFT CHEESE; SOUPS; SOY CHIPS; TINNED FRUITS; TUNA FISH; VEGETABLE CHIPS; VEGETABLE JUICE FOR COOKING; VEGETABLE OILS; VEGETABLE OILS AND FATS; VEGETABLE PASTE; VEGETABLE PUREE; VEGETABLES, INSTANT FROZEN; WHITE CHEESE; YOGURT; YOGURT DRINKS; YOGURT-BASED BEVERAGES; YUCCA CHIPS (U.S. CL. 46).

FIRST USE 12-1-2010; IN COMMERCE 12-1-2010.

CLASS 30—STAPLE FOODS

FOR BAGEL CHIPS; BAKING SPICES; BEAN PASTE; BEVERAGES MADE OF TEA; BLACK TEA; BROWN SUGAR; CHAI TEA; CHOCOLATE CHIPS; CINNAMON POWDER; CLOVE POWDER; COFFEE; COFFEE; COFFEE AND TEA; COFFEE BASED BEVERAGES; COFFEE BEANS; COFFEE BEVERAGES WITH MILK; COOKIES; COOKIES AND CRACKERS; CORN CHIPS; CURRY; CURRY POWDER; DRIED COOKED-RICE; DRY SPICE RUB FOR MEATS AND FISH; EDIBLE SPICES; FLOUR-BASED CHIPS; FOOD CONDIMENT CONSISTING PRIMARILY OF KETCHUP AND SALSA; FRUIT PASTE FOR FLAVORING OF FOOD; FRUIT TEAS; GINGER; GRAIN-BASED CHIPS; GRANULATED SUGAR; GREEN TEA; GROUND COFFEE BEANS; HERB TEA; HERBAL TEA; HONEY; HONEY; HOT PEPPER POWDER; ICED TEA; MASALA POWDER AND SPICES; MASALA RICE FOR BIRYANI; MUSTARD POWDER; NATURAL BROWN SUGAR; PASTA; PASTA AND NOODLES; PASTA FOR SOUPS; PASTA SHELLS; PEPPER; POWDERED SUGAR; RICE; RICE FLOUR; RICE NOODLES; RICE STARCH FLOUR; RICE-BASED SNACK FOODS; ROASTED COFFEE BEANS; SALSA; SPICE BLENDS; SPICES; SUGAR; TACO CHIPS; TEA; TEA BAGS; TEA-BASED BEVERAGES; TEA-BASED BEVERAGES WITH FRUIT FLAVORING; TOMATO-BASED SALSA; TORTILLA CHIPS; UNROASTED COFFEE; VEGETABLE CONCENTRATES USED FOR SEASONING; WHITE SUGAR; WHOLEMEAL RICE (U.S. CL. 46).

FIRST USE 12-1-2010; IN COMMERCE 12-1-2010.

4,119,038. META PHARMACEUTICAL SERVICES, BLUE BELL, PA. SN 77-946,154. PUB. 10-26-2010, FILED 2-26-2010.

BRANDVIEW

THE MARK CONSISTS OF STANDARD CHARACTERS WITHOUT CLAIM TO ANY PARTICULAR FONT, STYLE, SIZE, OR COLOR.

CLASS 9—ELECTRICAL AND SCIENTIFIC APPARATUS

FOR COMPUTER SOFTWARE PLATFORMS FOR TRACKING DATA TO HELP GROW AND MANAGE A PORTFOLIO OF BRANDS (U.S. CLS. 21, 23, 26, 36 AND 38).

FIRST USE 9-10-2010; IN COMMERCE 9-10-2010.

CLASS 42—SCIENTIFIC AND COMPUTER SERVICES

FOR PLATFORM AS A SERVICE (PAAS) FEATURING COMPUTER SOFTWARE PLATFORMS FOR USE TRACKING DATA TO HELP GROW AND MANAGE A PORTFOLIO OF BRANDS (U.S. CLS. 100 AND 101).

FIRST USE 9-10-2010; IN COMMERCE 9-10-2010.

4,119,040. META PHARMACEUTICAL SERVICES, BLUE BELL, PA. SN 77-947,178. PUB. 11-2-2010, FILED 3-1-2010.

REPSTART

THE MARK CONSISTS OF STANDARD CHARACTERS WITHOUT CLAIM TO ANY PARTICULAR FONT, STYLE, SIZE, OR COLOR.

CLASS 35—ADVERTISING AND BUSINESS

FOR BRANDING SERVICES, NAMELY, CONSULTING, DEVELOPMENT, MANAGEMENT AND MARKETING OF BRANDS FOR BUSINESSES; BUSINESS MANAGEMENT CONSULTING WITH RELATION TO STRATEGY, MARKETING, PRODUCTION, PERSONNEL AND RETAIL SALE MATTERS; BUSINESS MANAGEMENT AND CONSULTING SERVICES FOR THE HEALTH CARE INDUSTRY, NAMELY, CUSTOMER SERVICE, ACCOUNTING SERVICES, AND WEB-BASED ADVERTISING AND MARKETING SERVICES; BUSINESS MANAGEMENT CONSULTING WITH RELATION TO STRATEGY, MARKETING, SALES, OPERATION, PRODUCT DESIGN PARTICULARLY SPECIALIZING IN THE USE OF ANALYTIC AND STATISTIC MODELS FOR THE UNDERSTANDING AND PREDICTING OF CONSUMERS, BUSINESSES, AND MARKET TRENDS AND ACTIONS; BUSINESS MANAGEMENT AND CONSULTING SERVICES FOR THE HEALTH CARE INDUSTRY, NAMELY, CUSTOMER SERVICE, ACCOUNTING SERVICES, AND MARKETING SERVICES; BUSINESS MARKETING AND DIRECT MAIL CONSULTING SERVICES; BUSINESS MARKETING CONSULTING SERVICES; BUSINESS MONITORING AND CONSULTING SERVICES, NAMELY, TRACKING WEB SITES AND APPLICATIONS OF OTHERS TO PROVIDE STRATEGY, INSIGHT, MARKETING, SALES, OPERATION, PRODUCT DESIGN, PARTICULARLY SPECIALIZING IN THE USE OF ANALYTIC AND STATISTIC MODELS FOR THE UNDERSTANDING AND PREDICTING OF CONSUMERS, BUSINESSES, AND MARKET TRENDS AND ACTIONS; CONSULTING SERVICES IN THE FIELD OF MARKETING OF EDUCATIONAL TRAINING; CONSULTING SERVICES IN THE FIELD OF INTERNET MARKETING; CONSUMER MARKETING RESEARCH AND CONSULTING RELATED THERETO; CONSUMER STRATEGY BUSINESS CONSULTING IN THE FIELDS OF MARKETING, SALES, OPERATION, AND PRODUCT DESIGN PARTICULARLY SPECIALIZING IN THE USE OF ANALYTIC MODELS FOR THE UNDERSTANDING AND PREDICTING OF CONSUMER, BUSINESS, AND RETAIL MARKET TRENDS AND ACTIONS; DIRECT MARKETING CONSULTING SERVICES; MARKETING AND CONSULTING SERVICES IN THE FIELD OF PROMOTING AND TRACKING THE GOODS, SERVICES, AND BRANDS OF OTHERS THROUGH ALL PUBLIC COMMUNICATION MEANS, PARTICULARLY SPECIALIZING IN THE USE OF MOBILE, SOCIAL, AND PRINT MEDIA TO DRIVE CONSUMER INTEREST, ENGAGEMENT AND ACTION; MARKETING CONSULTING; PROMOTION AND MARKETING SERVICES AND RELATED CONSULTING; CONDUCTING MARKETING STUDIES; BUSINESS MARKETING SERVICES; MARKETING PLAN DEVELOPMENT (U.S. CLS. 100, 101 AND 102).

FIRST USE 12-2-2010; IN COMMERCE 12-2-2010.

CLASS 41—EDUCATION AND ENTERTAINMENT

FOR TRAINING COURSES IN STRATEGIC PLANNING RELATING TO ADVERTISING, PROMOTION, MARKETING AND BUSINESS; EDUCATION SERVICES, NAMELY, MENTORING IN THE FIELD OF PHARMACEUTICALS, SALES, BRAND MANAGEMENT, AND BRAND DEVELOPMENT; EDUCATIONAL SERVICES, NAMELY, PROVIDING CLASSES, SEMINARS, AND WORKSHOP IN THE FIELDS OF PHARMACEUTICALS, SALES, BRAND MANAGEMENT, AND BRAND DEVELOPMENT; EDUCATION SERVICES, NAMELY, PROVIDING ON-LINE CLASSES, SEMINARS, AND WORKSHOPS IN THE FIELD OF PHARMACEUTICALS, SALES, BRAND MANAGEMENT, AND BRAND DEVELOPMENT; PROVIDING ON-LINE TRAINING COURSES, SEMINARS, AND WORKSHOPS IN THE FIELD OF PHARMACEUTICALS, SALES, BRAND MANAGEMENT, AND BRAND DEVELOPMENT; WORKSHOPS AND SEMINARS IN THE FIELD OF PHARMACEUTICALS, SALES, BRAND MANAGEMENT, AND BRAND DEVELOPMENT (U.S. CLS. 100, 101 AND 107).

FIRST USE 12-2-2010; IN COMMERCE 12-2-2010.

4,119,042. MIND-BUGS LLC, SANDY SPRINGS, GA. SN 77-955,269. PUB. 9-14-2010, FILED 3-10-2010.

Mind-Bugs

THE MARK CONSISTS OF STANDARD CHARACTERS WITHOUT CLAIM TO ANY PARTICULAR FONT, STYLE, SIZE, OR COLOR.

CLASS 16—PAPER GOODS AND PRINTED MATTER

FOR A SERIES OF BOOKS AND WRITTEN ARTICLES ON THE SUBJECT OF IMPROVED DECISION MAKING PERTAINING SPECIFICALLY TO THE FIELDS OF BUSINESS AND INDIVIDUAL INVESTMENT, BUSINESS AND INDIVIDUAL RISK MANAGEMENT, CORPORATE INNOVATION AND GROWTH PROCESSES, HUMAN RESOURCES DEVELOPMENT, ORGANIZATIONAL TRANSFORMATION AND CULTURE, PSYCHOLOGY, PHILOSOPHY AND SPIRITUALITY (U.S. CLS. 2, 5, 22, 23, 29, 37, 38 AND 50).

FIRST USE 12-15-2010; IN COMMERCE 12-15-2010.

CLASS 35—ADVERTISING AND BUSINESS

FOR BUSINESS RISK MANAGEMENT; CONSULTING SERVICES IN THE FIELD OF HUMAN RESOURCES DEVELOPMENT, NAMELY, UTILIZING TECHNOLOGY FOR THE PROMOTION OF EMPLOYEE RETENTION, CAREER GROWTH AND INCREASED PRODUCTIVITY FOR EMPLOYEES AND EMPLOYERS; MANAGEMENT CONSULTING AND ADVISORY SERVICES IN THE AREAS OF CORPORATE GROWTH STRATEGY, INNOVATION AND GROWTH PROCESSES, ORGANIZATIONAL TRANSFORMATION, AND TALENT MANAGEMENT AND DEVELOPMENT STRATEGIES (U.S. CLS. 100, 101 AND 102).

FIRST USE 12-15-2010; IN COMMERCE 12-15-2010.

CLASS 45—PERSONAL AND LEGAL SERVICES

FOR PROVIDING A RESOURCE WEBSITE FEATURING INFORMATION IN THE FIELD OF SELF-DEVELOPMENT; PROVIDING INFORMATION IN THE FIELD OF SELF-IMPROVEMENT (U.S. CLS. 100 AND 101).

FIRST USE 12-15-2010; IN COMMERCE 12-15-2010.

4,119,044. STAT HEALTH SERVICES, INC., SANTA ANA, CA. SN 77-959,080. PUB. 6-7-2011, FILED 3-15-2010.

STAT DOCTORS
Getting Better Just Got Easier

NO CLAIM IS MADE TO THE EXCLUSIVE RIGHT TO USE "DOCTORS", APART FROM THE MARK AS SHOWN.

THE MARK CONSISTS OF AN ARC OF CIRCLES OVER THE WORDS "STAT DOCTORS", STARTING AT THE "T" (WHICH INCLUDES A STETHOSCOPE SHAPE WITHIN IT) PORTION OF THE "STAT" WORD AND ENDING AT THE "R" PORTION OF THE "DOCTORS" WORD, ALL OF WHICH IS ABOVE THE "GETTING BETTER JUST GOT EASIER" PORTION OF THE MARK.

CLASS 35—ADVERTISING AND BUSINESS

FOR PROVIDING ON-LINE ORDERING SERVICES FEATURING MEDICAL ITEMS, NAMELY, PRESCRIPTION MEDICATION, AND PRESCRIPTION-ONLY DEVICES, OTHER THAN CONTROLLED SUBSTANCES (U.S. CLS. 100, 101 AND 102).

FIRST USE 12-6-2010; IN COMMERCE 12-6-2010.

CLASS 44—MEDICAL, BEAUTY AND AGRICULTURAL SERVICES

FOR PROVIDING ON-LINE HEALTH CARE SERVICES, NAMELY, MEDICAL CONSULTING, DIAGNOSIS AND TREATMENT AND MEDICAL FOLLOW-UP SERVICES FOR TREATING COMMON MEDICAL CONDITIONS; PROVIDING ON-LINE HEALTH CARE SERVICES, NAMELY, MEDICAL SERVICES IN THE NATURE OF ORDERING MEDICAL LABORATORY TESTS AND X-RAYS FOR PATIENTS NEEDING THEM; MAINTENANCE OF PATIENTS' MEDICAL RECORDS UTILIZING AN INTERACTIVE AUDIO/VISUAL DATA COMMUNICATIONS WEB-BASED STORAGE CENTER (U.S. CLS. 100 AND 101).

FIRST USE 12-6-2010; IN COMMERCE 12-6-2010.

4,119,053. LOUISIANA ENERGY SERVICES, LLC, WILMINGTON, NEW CASTLE, DE. SN 77-982,912. PUB. 11-9-2010, FILED 9-25-2008.

LES

THE MARK CONSISTS OF STANDARD CHARACTERS WITHOUT CLAIM TO ANY PARTICULAR FONT, STYLE, SIZE, OR COLOR.

CLASS 35—ADVERTISING AND BUSINESS

FOR PROCUREMENT AND SUPPLY OF URANIUM AND URANIUM HEXAFLUORIDE FEED MATERIALS ON BEHALF OF BUSINESSES; CONSULTANCY RELATING TO URANIUM AND ENRICHED URANIUM (U.S. CLS. 100, 101 AND 102).

FIRST USE 6-0-2006; IN COMMERCE 6-0-2006.

CLASS 39—TRANSPORTATION AND STORAGE

FOR TRANSPORTATION AND STORAGE OF URANIUM AND ENRICHED URANIUM; PACKAGING OF URANIUM AND ENRICHED URANIUM FOR TRANSPORTATION; SERVICES FOR THE STORAGE OF URANIUM; SERVICES FOR THE STORAGE OF DEPLETED URANIUM HEXAFLUORIDE; SERVICES FOR THE STORAGE OF DERIVATIVES OF URANIUM AND PRODUCTS PRODUCED DURING URANIUM ENRICHMENT AND DECONVERSION PROCESSES (U.S. CLS. 100 AND 105).

FIRST USE 6-0-2006; IN COMMERCE 6-0-2006.

CLASS 40—MATERIAL TREATMENT

FOR TREATMENT OF MATERIALS, NAMELY, ENRICHMENT OF URANIUM AND ENRICHMENT OF URANIUM ISOTOPE 2235; RE-ENRICHMENT OF DEPLETED URANIUM HEXAFLUORIDE; TRANSFORMATION AND CONVERSION OF URANIUM HEXAFLUORIDE TO URANIUM OXIDE THROUGH TREATMENT OF THE URANIUM; REPROCESSING OF NUCLEAR FUELS; CONTRACT SERVICES RELATING TO URANIUM ENRICHMENT, NAMELY, PROCESSING OF URANIUM FOR OTHERS (U.S. CLS. 100, 103 AND 106).

FIRST USE 6-0-2006; IN COMMERCE 6-0-2006.

4,119,056. FACEBOOK, INC., MENLO PARK, CA. SN 77-982,988. PUB. 2-22-2011, FILED 3-26-2010.

F8

THE MARK CONSISTS OF STANDARD CHARACTERS WITHOUT CLAIM TO ANY PARTICULAR FONT, STYLE, SIZE, OR COLOR.

CLASS 35—ADVERTISING AND BUSINESS

FOR ORGANIZING EXHIBITIONS AND EVENTS IN THE FIELD OF SOFTWARE DEVELOPMENT FOR COMMERCIAL OR ADVERTISING PURPOSES (U.S. CLS. 100, 101 AND 102).

FIRST USE 5-0-2007; IN COMMERCE 5-0-2007.

CLASS 41—EDUCATION AND ENTERTAINMENT

FOR ON-LINE JOURNALS, NAMELY, BLOGS IN THE FIELD OF ENTERTAINMENT, EDUCATION, SOCIAL, SCIENTIFIC AND GENERAL INTEREST; ARRANGING AND CONDUCTING EDUCATIONAL CONFERENCES; ORGANIZING EXHIBITIONS AND EVENTS IN THE FIELD OF SOFTWARE DEVELOPMENT FOR EDUCATIONAL PURPOSES (U.S. CLS. 100, 101 AND 107).

FIRST USE 5-0-2007; IN COMMERCE 5-0-2007.

4,119,057. STARZ ENTERTAINMENT, LLC, ENGLEWOOD, CO. SN 78-559,851. PUB. 5-3-2011, FILED 2-3-2005.

EDGE

THE MARK CONSISTS OF STANDARD CHARACTERS WITHOUT CLAIM TO ANY PARTICULAR FONT, STYLE,

SIZE, OR COLOR.

OWNER OF U.S. REG. NO. 3,096,752.

CLASS 38—COMMUNICATION

FOR VIDEO AND AUDIO BROADCASTING AND TRANSMISSION; TELEVISION BROADCASTING AND TRANSMISSION; CABLE AND SATELLITE TELEVISION BROADCASTING; SUBSCRIPTION TELEVISION BROADCASTING AND TRANSMISSION; VIDEO-ON-DEMAND TRANSMISSION; COMMUNICATION SERVICES, NAMELY, TRANSMISSION OF VISUAL IMAGES AND AUDIO VIA A GLOBAL COMPUTER NETWORK (U.S. CLS. 100, 101 AND 104).

FIRST USE 5-1-2006; IN COMMERCE 5-1-2006.

CLASS 41—EDUCATION AND ENTERTAINMENT

FOR ENTERTAINMENT SERVICES IN THE NATURE OF VIDEO AND AUDIO PROGRAMMING, TELEVISION PROGRAMMING; PRODUCTION AND DISTRIBUTION OF MOTION PICTURES; TELEVISION PROGRAMMING ON A GLOBAL COMPUTER NETWORK; PRODUCTION AND DISTRIBUTION OF TELEVISION AND MOTION PICTURE PROGRAMMING FOR TELEVISION BROADCASTING AND TRANSMISSION VIA A GLOBAL COMPUTER NETWORK (U.S. CLS. 100, 101 AND 107).

FIRST USE 5-1-2006; IN COMMERCE 5-1-2006.

4,119,060. OMIDYAR NETWORK COMMONS, LLC, REDWOOD CITY, CA. SN 78-909,419. PUB. 2-19-2008, FILED 6-15-2006.

HUMANITY UNITED

THE MARK CONSISTS OF STANDARD CHARACTERS WITHOUT CLAIM TO ANY PARTICULAR FONT, STYLE, SIZE, OR COLOR.

CLASS 35—ADVERTISING AND BUSINESS

FOR PUBLIC POLICY RESEARCH SERVICES AIMED AT ENDING MASS ATROCITIES AND HUMAN SLAVERY; ADVOCATING ON BEHALF OF OTHERS BY PROMOTING PUBLIC AWARENESS OF THE NEED FOR, AND PROMOTING PUBLIC SUPPORT OF AND PARTICIPATION IN EFFORTS AIMED AT ENDING MASS ATROCITIES AND HUMAN SLAVERY; ADVOCATING ON BEHALF OF OTHERS BY CONDUCTING MARKET AND PUBLIC POLICY RESEARCH AND ANALYSIS, NAMELY, INFORMATION GATHERING, STUDY, FIELD-BASED ANALYSIS, INVESTIGATION OF NEW APPROACHES, AND ITERATIVE REFINEMENT OF IDEAS AND PLANS IN COLLABORATION WITH OTHERS, ALL TO PROMOTE THE DEVELOPMENT OF SOLUTIONS FOR THE PROTECTION OF HUMAN RIGHTS AND THE PROMOTION OF HUMAN DIGNITY; ADVOCATING ON BEHALF OF OTHERS THROUGH LOBBYING OF COMMERCIAL, NOT-FOR-PROFIT, GOVERNMENTAL, AND NON-GOVERNMENTAL ORGANIZATIONS IN SUPPORT OF ADOPTING AND SUPPORTING MEASURES FOR THE PROTECTION OF HUMAN RIGHTS AND THE PROMOTION OF HUMAN DIGNITY; CHARITABLE SERVICES, NAMELY, ORGANIZING NETWORKS OF INDIVIDUALS AND INSTITUTIONS WITH THE PURPOSE OF FACILITATING AND FURTHERING THE IMPLEMENTATION OF CHARITABLE AND PHILANTHROPIC PROGRAMS; ADMINISTRATION AND MANAGEMENT OF RESEARCH GRANTS; EDUCATION LEADERSHIP DEVELOPMENT; MARKET RESEARCH; PUBLIC OPINION POLLING; PUBLIC OPINION SURVEYS; CONDUCTING MARKET RESEARCH SURVEYS; PROMOTING PUBLIC

AWARENESS OF HUMAN NEEDS, NAMELY, PROMOTING PUBLIC AWARENESS OF THE SCOPE OF, THE NEED TO ADDRESS, INSTITUTIONAL OBSTACLES TO, SOLUTIONS FOR, AND THE ROLE OF VARIOUS ACTORS IN RELATION TO THREATS TO BASIC HUMAN RIGHTS, MASS ATROCITIES, HUMAN SLAVERY AND HUMAN CRUELTY; EMPLOYMENT AND NETWORK RECRUITING, NAMELY, RECRUITING PROFESSIONALS, VOLUNTEERS AND WORKERS IN THE FIELD OF CHARITABLE ACTIVITIES RELATING TO ENDING MASS ATROCITIES AND HUMAN SLAVERY, RELIEF OF POVERTY AND HUNGER, HEALTH AND ACCESS TO MEDICAL CARE, EDUCATION AND SOCIAL WELFARE, HUMAN RIGHTS AND MOBILITY, AND DISASTER RELIEF; PROMOTING ECONOMIC DEVELOPMENT THROUGH THE PROVISION OF BUSINESS AND MANAGERIAL CONSULTATION, AND BUSINESS INFORMATION IN THE FIELD OF PLANNING, ORGANIZING, MONITORING AND IMPLEMENTING PROJECTS AIMED AT BUILDING ENDURING INSTITUTIONS AND PRACTICES, ENCOURAGING GROWTH AND ENTREPRENEURSHIP THROUGH MICROFINANCE AND OTHER FORMS OF CREDIT, ENSURING ACCOUNTABILITY, AND SUPPORTING ECONOMIC AND POLITICAL STABILITY BY ADDRESSING BASIC HUMAN RIGHTS; PROMOTING ECONOMIC DEVELOPMENT THROUGH PUBLIC ADVOCACY IN THE NATURE OF PROMOTING AWARENESS OF THE NEED FOR PLANNING, ORGANIZING, MONITORING AND IMPLEMENTING PROJECTS AIMED AT BUILDING ENDURING INSTITUTIONS AND PRACTICES, ENCOURAGING GROWTH AND ENTREPRENEURSHIP THROUGH MICROFINANCE AND OTHER FORMS OF CREDIT, ENSURING ACCOUNTABILITY, AND SUPPORTING ECONOMIC AND POLITICAL STABILITY BY ADDRESSING BASIC HUMAN RIGHTS; CHARITABLE SERVICES, NAMELY, SUPPORTING NETWORKS OF CHARITABLE AND PHILANTHROPIC INDIVIDUALS AND INSTITUTIONS BY PROVIDING CONSULTATION AND ADVICE REGARDING ADVERTISING, AND CREATION AND DISSEMINATION OF ADVERTISING MATERIALS FOR EDUCATIONAL ACTIVITIES AND ENTERTAINMENT EVENTS, WITH THE PURPOSE OF FACILITATING AND FURTHERING THE IMPLEMENTATION OF CHARITABLE AND PHILANTHROPIC PROGRAMS (U.S. CLS. 100, 101 AND 102).

FIRST USE 7-1-2008; IN COMMERCE 7-1-2008.

CLASS 36—INSURANCE AND FINANCIAL

FOR CHARITABLE FUNDRAISING; PHILANTHROPIC SERVICES CONCERNING MONETARY DONATIONS; PROVIDING GRANTS AND MONETARY DONATIONS TO ORGANIZATIONS AND INDIVIDUALS PROMOTING AWARENESS OF, ORGANIZING RESPONSES TO, AND PROVIDING SERVICES TO ADDRESS MASS ATROCITIES, HUMAN SLAVERY, HUMAN CRUELTY, THE PROTECTION OF HUMAN RIGHTS AND THE PROMOTION OF HUMAN DIGNITY; PROVIDING GRANTS AND MONETARY DONATIONS TO ORGANIZATIONS AND INDIVIDUALS WORKING TO BUILD ENDURING INSTITUTIONS AND PRACTICES TO REDUCE THE INCIDENCE AND LIMIT THE IMPACT OF MASS ATROCITIES AND OTHER VIOLATIONS OF BASIC HUMAN RIGHTS; PROVIDING GRANTS AND MONETARY DONATIONS TO ORGANIZATIONS AND INDIVIDUALS WORKING TO MOVE PUBLIC POLICY AND POLITICAL WILL TOWARD PRODUCTIVE INTERVENTION TO PREVENT OR STOP MASS ATROCITIES AND OTHER VIOLATIONS OF BASIC HUMAN RIGHTS; CHARITABLE SERVICES, NAMELY, PROVIDING GRANTS AND MONETARY DONATIONS TO SUPPORT NETWORKS OF INDIVIDUALS AND INSTITUTIONS WITH THE PURPOSE OF FACILITATING AND FURTHERING THE IMPLEMENTATION OF CHARITABLE AND PHILANTHROPIC PROGRAMS; PROVIDING GRANTS AND MONETARY DONATIONS TO SUPPORT PROJECTS AIMED AT BUILDING ENDURING INSTITUTIONS AND PRACTICES, ENCOURAGING GROWTH AND ENTREPRENEURSHIP THROUGH MICROFINANCE AND OTHER FORMS OF CREDIT, ENSURING ACCOUNTABILITY, AND SUPPORTING ECONOMIC AND POLITICAL STABILITY BY ADDRESSING BASIC HUMAN RIGHTS (U.S. CLS. 100, 101 AND 102).

FIRST USE 7-1-2008; IN COMMERCE 7-1-2008.

CLASS 41—EDUCATION AND ENTERTAINMENT

FOR DEVELOPMENT AND DISSEMINATION OF EDUCATIONAL MATERIALS TO OTHERS IN RELATION TO PROMOTING AWARENESS OF, ORGANIZING RESPONSES TO, AND PROVIDING SERVICES TO ADDRESS MASS ATROCITIES, HUMAN SLAVERY, HUMAN CRUELTY, THE PROTECTION OF HUMAN RIGHTS AND THE PROMOTION OF HUMAN DIGNITY; ARRANGING AND CONDUCTING OF EDUCATIONAL CONFERENCES, DISCUSSIONS, AND COLLOQUIA; ARRANGING AND CONDUCTING ONLINE EDUCATIONAL CONFERENCES, DISCUSSIONS, AND COLLOQUIA VIA COMPUTER AND COMMUNICATION NETWORKS IN THE FIELDS OF EDUCATION, COLLABORATION, COORDINATION, AND SUPPORT IN RELATION TO PROMOTING AWARENESS OF, ORGANIZING RESPONSES TO, AND PROVIDING SERVICES TO ADDRESS MASS ATROCITIES, HUMAN SLAVERY, HUMAN CRUELTY, THE PROTECTION OF HUMAN RIGHTS AND THE PROMOTION OF HUMAN DIGNITY (U.S. CLS. 100, 101 AND 107).

FIRST USE 7-1-2008; IN COMMERCE 7-1-2008.

CLASS 45—PERSONAL AND LEGAL SERVICES

FOR ADVOCATING ON BEHALF OF OTHERS, NAMELY, LEGAL CONSULTATION AND LEGAL SERVICES IN THE FIELDS OF NEGOTIATION, PROSECUTION SUPPORT, AND LEGAL REPRESENTATION RELATING TO THE PROTECTION OF HUMAN RIGHTS AND THE PROMOTION OF HUMAN DIGNITY (U.S. CLS. 100 AND 101).

FIRST USE 7-1-2008; IN COMMERCE 7-1-2008.

4,119,061. QUICKPLAY MEDIA INC., TORONTO, CANADA.
SN 78-943,107. PUB. 10-6-2009, FILED 8-2-2006.

QUICKPLAY MEDIA

THE MARK CONSISTS OF STANDARD CHARACTERS WITHOUT CLAIM TO ANY PARTICULAR FONT, STYLE, SIZE, OR COLOR.

PRIORITY CLAIMED UNDER SEC. 44(D) ON CANADA APPLICATION NO. 1288413, FILED 2-2-2006, REG. NO. TMA708,875, DATED 3-4-2008, EXPIRES 3-4-2023.

NO CLAIM IS MADE TO THE EXCLUSIVE RIGHT TO USE "MEDIA", APART FROM THE MARK AS SHOWN.

CLASS 9—ELECTRICAL AND SCIENTIFIC APPARATUS

FOR DOWNLOADABLE DIGITAL MEDIA FILES CONTAINING TEXT ON NEWS IN THE NATURE OF CURRENT EVENTS, SPORTS IN THE NATURE OF PROFESSIONAL, COLLEGE, AMATEUR AND EXTREME SPORTS, AND ENTERTAINMENT IN THE NATURE OF GOSSIP AND COMEDY, ARTWORK, VIDEO FEATURING NEWS IN THE NATURE OF CURRENT EVENTS AND FINANCE, SPORTING EVENTS IN THE NATURE OF PROFESSIONAL, COLLEGE, AMATEUR AND EXTREME SPORTS, WEATHER, ENTERTAINMENT IN THE NATURE OF GOSSIP, COMEDY, ADULT-THEMED VIDEOS, MUSIC VIDEOS, AND MOVIE TRAILERS PROVIDED OVER GLOBAL COMPUTER AND COMMUNICATION NETWORKS AND VIA WIRELESS DEVICES (U.S. CLS. 21, 23, 26, 36 AND 38).

FIRST USE 8-12-2008; IN COMMERCE 8-12-2008.

CLASS 38—COMMUNICATION

FOR WIRELESS TELECOMMUNICATION SERVICES, NAMELY, THE TRANSMISSION OF TEXT, IMAGES, VIDEO, AND AUDIO FOR DELIVERY TO WIRELESS COMMUNICATION DEVICES (U.S. CLS. 100, 101 AND 104).

FIRST USE 3-31-2007; IN COMMERCE 3-31-2007.

4,119,073. MIXED BUSINESS INC., NEW YORK, NY. SN 85-008,979. PUB. 6-14-2011, FILED 4-7-2010.

OWNER OF U.S. REG. NO. 3,646,581.
THE MARK CONSISTS OF THE STYLIZED WORDING "D'BRIEF" UNDERLINED.

4,119,071. MUSICAL EXPERIENCE, INC., DBA MUSICAL KIDS INTERNATIONAL, NEW YORK, NY. SN 85-006,100. PUB. 11-9-2010, FILED 4-5-2010.

CLASS 25—CLOTHING

FOR CLOTHING AND APPAREL, NAMELY, PANTS, SHIRTS, FOOTWEAR (U.S. CLS. 22 AND 39).
FIRST USE 1-1-2012; IN COMMERCE 1-1-2012.

CLASS 35—ADVERTISING AND BUSINESS

FOR RETAIL STORE SERVICES AND ONLINE RETAIL STORE SERVICES FEATURING CLOTHING (U.S. CLS. 100, 101 AND 102).
FIRST USE 1-1-2012; IN COMMERCE 1-1-2012.



NO CLAIM IS MADE TO THE EXCLUSIVE RIGHT TO USE "LANGUAGES THROUGH MUSIC", APART FROM THE MARK AS SHOWN.

THE MARK CONSISTS OF THE IMAGE OF A MOUSE, HOLDING UP A SIGN, WHICH IS AN IRREGULARLY SHAPED DIALOGUE BALLOON DEPICTING THE WORDS: "I'M BILINGUAL" FOLLOWED BY AN EXCLAMATION POINT AND BELOW IT THE WORDS "LANGUAGES THROUGH MUSIC".

CLASS 9—ELECTRICAL AND SCIENTIFIC APPARATUS

FOR DIGITAL MATERIALS, NAMELY, CDS, DVDS, DOWNLOADABLE AUDIO FILES, FEATURING EDUCATIONAL MUSIC (U.S. CLS. 21, 23, 26, 36 AND 38).
FIRST USE 9-1-2010; IN COMMERCE 9-1-2010.

CLASS 16—PAPER GOODS AND PRINTED MATTER

FOR EDUCATIONAL PUBLICATIONS, NAMELY, ACTIVITY BOOKS, STORY BOOKS, SONG BOOKS, MANUALS, POSTERS AND EDUCATIONAL BOOKLETS IN THE FIELD OF MUSIC EDUCATION (U.S. CLS. 2, 5, 22, 23, 29, 37, 38 AND 50).
FIRST USE 9-1-2010; IN COMMERCE 9-1-2010.

CLASS 41—EDUCATION AND ENTERTAINMENT

FOR EDUCATIONAL SERVICES, NAMELY, CONDUCTING CLASSES IN THE FIELD OF MUSIC EDUCATION, INCLUDING VIA A GLOBAL COMPUTER NETWORK (U.S. CLS. 100, 101 AND 107).
FIRST USE 9-1-2010; IN COMMERCE 9-1-2010.

4,119,092. FEDERAL EXPRESS CORPORATION, MEMPHIS, TN. SN 85-031,942. PUB. 5-10-2011, FILED 5-6-2010.

OWNER OF U.S. REG. NOS. 1,109,701, 1,878,998, AND OTHERS.
THE MARK CONSISTS OF "KINKO'S" IN STYLIZED LETTERS.

CLASS 35—ADVERTISING AND BUSINESS

FOR ADVERTISING AND BUSINESS SERVICES, NAMELY, PHOTOCOPYING SERVICES; RENTAL OF OFFICE MACHINERY AND EQUIPMENT; PHOTOCOPYING AND REPRODUCING AND COMPILING DOCUMENTS FOR OTHERS; PREPARING PUBLICITY DOCUMENTS; LEASE AND RENTAL OF COPY MACHINES, TYPEWRITERS AND WORD PROCESSORS (U.S. CLS. 100, 101 AND 102).
FIRST USE 10-1-1970; IN COMMERCE 2-1-1976.

CLASS 40—MATERIAL TREATMENT

FOR TREATMENT OF MATERIALS, NAMELY, THE LAMINATING AND COLLATING OF DOCUMENTS, PHOTOGRAPHS, SIGNS, BANNERS, AND CERTIFICATES; ASSEMBLING OF DOCUMENTS; PHOTOGRAPHIC REPRODUCTION SERVICES; FILM DEVELOPING; BOOK BINDING AND DOCUMENT BINDING; DEVELOPMENT AND ENLARGEMENT OF PHOTOGRAPHIC FILM; ELECTRONIC AND DIGITAL IMAGING, SCANNING, DIGITIZING, ALTERATION AND/OR RETOUCH OF PHOTOGRAPHIC IMAGES, PRINTING (U.S. CLS. 100, 103 AND 106).
FIRST USE 10-1-1970; IN COMMERCE 2-1-1976.

4,119,094. FEDERATED TELEPHONE COOPERATIVE, CHOKIO, MN. SN 85-032,690. PUB. 5-10-2011, FILED 5-7-2010.

4,119,096. FLUOR ENTERPRISES, INC., IRVING, TX. SN 85-035,880. PUB. 6-7-2011, FILED 5-11-2010.

ACIRA

THE MARK CONSISTS OF STANDARD CHARACTERS WITHOUT CLAIM TO ANY PARTICULAR FONT, STYLE, SIZE, OR COLOR.

THE WORDING "ACIRA" HAS NO MEANING IN A FOREIGN LANGUAGE.

CLASS 37—CONSTRUCTION AND REPAIR

FOR INSTALLATION, MAINTENANCE AND REPAIR OF TELECOMMUNICATIONS NETWORKING HARDWARE, APPARATUS, AND INSTRUMENTS; TELECOMMUNICATIONS WIRING (U.S. CLS. 100, 103 AND 106).
FIRST USE 10-0-2011; IN COMMERCE 10-0-2011.

CLASS 38—COMMUNICATION

FOR TELECOMMUNICATIONS SERVICES, NAMELY, LOCAL AND LONG DISTANCE TELEPHONE SERVICES; PROVIDING THIRD PARTY USERS WITH ACCESS TO TELECOMMUNICATION INFRASTRUCTURE; TELECOMMUNICATION SERVICES, NAMELY, LOCAL AND LONG DISTANCE TRANSMISSION OF VOICE, DATA, GRAPHICS AND VIDEO BY MEANS OF BROADBAND OPTICAL OR WIRELESS NETWORKS; TELECOMMUNICATION SERVICES, NAMELY, LOCAL AND LONG DISTANCE TRANSMISSION OF VOICE, DATA, GRAPHICS BY MEANS OF TELEPHONE, TELEGRAPHIC, CABLE, AND SATELLITE TRANSMISSIONS; TELECOMMUNICATION SERVICES, NAMELY, PROVIDING ADVANCED CALLING FEATURES; WIRELESS TELEPHONE TELECOMMUNICATIONS SERVICES, NAMELY, WIRELESS MOBILE TELEPHONE CALLING PLANS; TELECOMMUNICATION SERVICES, NAMELY, PROVIDING INTERNET ACCESS VIA BROADBAND OPTICAL OR WIRELESS NETWORKS; TELECOMMUNICATION SERVICES, NAMELY, TRANSMISSION OF VOICE, DATA, GRAPHICS, IMAGES, AUDIO AND VIDEO BY MEANS OF TELECOMMUNICATIONS NETWORKS, WIRELESS COMMUNICATION NETWORKS, AND THE INTERNET; TELECOMMUNICATION SERVICES, NAMELY, TRANSMISSION OF VOICE, DATA, GRAPHICS, SOUND AND VIDEO BY MEANS OF BROADBAND POWER LINE OR WIRELESS NETWORKS; TELECOMMUNICATIONS SERVICES, NAMELY, WIRELESS TELEPHONY AND WIRELESS BROADBAND COMMUNICATIONS SERVICES FOR THE TRANSMISSION OF VOICE AND DATA; VOICE OVER INTERNET PROTOCOL (VOIP) SERVICES; WIRELESS BROADBAND COMMUNICATION SERVICES (U.S. CLS. 100, 101 AND 104).
FIRST USE 10-0-2011; IN COMMERCE 10-0-2011.

CLASS 42—SCIENTIFIC AND COMPUTER SERVICES

FOR HOSTING THE WEB SITES OF OTHERS ON A COMPUTER SERVER FOR A GLOBAL COMPUTER NETWORK; INSTALLATION AND MAINTENANCE OF INTERNET ACCESS SOFTWARE (U.S. CLS. 100 AND 101).
FIRST USE 10-0-2011; IN COMMERCE 10-0-2011.

NEXTGEN

THE MARK CONSISTS OF STANDARD CHARACTERS WITHOUT CLAIM TO ANY PARTICULAR FONT, STYLE, SIZE, OR COLOR.

CLASS 37—CONSTRUCTION AND REPAIR

FOR BUILDING CONSTRUCTION CONSULTING SERVICES, PROJECT PLANNING SERVICES, LAYOUT SERVICES, AND CONSTRUCTION SERVICES FOR COMPLEX CAPITAL PROJECTS FOR INDUSTRIAL FACILITIES UTILIZING MODIFIABLE SOFTWARE FOR THE PURPOSE OF STANDARDIZING THE EXCHANGE AND MANAGEMENT OF DATA BETWEEN MULTIPLE PROJECT PARTNERS (U.S. CLS. 100, 103 AND 106).
FIRST USE 6-7-2011; IN COMMERCE 6-7-2011.

CLASS 42—SCIENTIFIC AND COMPUTER SERVICES

FOR ENGINEERING AND DESIGN CONSULTING SERVICES, ENGINEERING SERVICES AND DESIGN SERVICES FOR COMPLEX CAPITAL PROJECTS FOR INDUSTRIAL FACILITIES UTILIZING MODIFIABLE SOFTWARE FOR THE PURPOSE OF STANDARDIZING THE EXCHANGE AND MANAGEMENT OF DATA BETWEEN MULTIPLE PROJECT PARTNERS (U.S. CLS. 100 AND 101).
FIRST USE 6-7-2011; IN COMMERCE 6-7-2011.

4,119,097. FLUOR ENTERPRISES, INC., IRVING, TX. SN 85-035,884. PUB. 6-7-2011, FILED 5-11-2010.

NEXTGENERATION

THE MARK CONSISTS OF STANDARD CHARACTERS WITHOUT CLAIM TO ANY PARTICULAR FONT, STYLE, SIZE, OR COLOR.

CLASS 37—CONSTRUCTION AND REPAIR

FOR BUILDING CONSTRUCTION CONSULTING SERVICES, PROJECT PLANNING SERVICES, LAYOUT SERVICES, AND CONSTRUCTION SERVICES FOR COMPLEX CAPITAL PROJECTS FOR INDUSTRIAL FACILITIES UTILIZING MODIFIABLE SOFTWARE FOR THE PURPOSE OF STANDARDIZING THE EXCHANGE AND MANAGEMENT OF DATA BETWEEN MULTIPLE PROJECT PARTNERS (U.S. CLS. 100, 103 AND 106).
FIRST USE 6-7-2011; IN COMMERCE 6-7-2011.

CLASS 42—SCIENTIFIC AND COMPUTER SERVICES

FOR ENGINEERING AND DESIGN CONSULTING SERVICES, ENGINEERING SERVICES AND DESIGN SERVICES FOR COMPLEX CAPITAL PROJECTS FOR INDUSTRIAL FACILITIES UTILIZING MODIFIABLE SOFTWARE FOR THE PURPOSE OF STANDARDIZING THE EXCHANGE AND MANAGEMENT OF DATA BETWEEN MULTIPLE PROJECT PARTNERS (U.S. CLS. 100 AND 101).

FIRST USE 6-7-2011; IN COMMERCE 6-7-2011.

4,119,098. FLUOR ENTERPRISES, INC., IRVING, TX. SN 85-036,862. PUB. 6-7-2011, FILED 5-12-2010.



THE MARK CONSISTS OF THE WORD "NEXTGENERATION" AND THE DESIGN OF THREE CONCENTRIC OVALS, A SERIES OF VERTICAL DOTS TO THE LEFT AND A SERIES OF VERTICAL DOTS TO THE RIGHT OF THE OVALS, SAID DESIGN APPEARING TO THE LEFT OF THE WORD "NEXTGENERATION".

CLASS 37—CONSTRUCTION AND REPAIR

FOR BUILDING CONSTRUCTION CONSULTING SERVICES, PROJECT PLANNING SERVICES, LAYOUT SERVICES, AND CONSTRUCTION SERVICES FOR COMPLEX CAPITAL PROJECTS FOR INDUSTRIAL FACILITIES UTILIZING MODIFIABLE SOFTWARE FOR THE PURPOSE OF STANDARDIZING THE EXCHANGE AND MANAGEMENT OF DATA BETWEEN MULTIPLE PROJECT PARTNERS (U.S. CLS. 100, 103 AND 106).

FIRST USE 6-7-2011; IN COMMERCE 6-7-2011.

CLASS 42—SCIENTIFIC AND COMPUTER SERVICES

FOR ENGINEERING AND DESIGN CONSULTING SERVICES, ENGINEERING SERVICES AND DESIGN SERVICES FOR COMPLEX CAPITAL PROJECTS FOR INDUSTRIAL FACILITIES UTILIZING MODIFIABLE SOFTWARE FOR THE PURPOSE OF STANDARDIZING THE EXCHANGE AND MANAGEMENT OF DATA BETWEEN MULTIPLE PROJECT PARTNERS (U.S. CLS. 100 AND 101).

FIRST USE 6-7-2011; IN COMMERCE 6-7-2011.

4,119,105. INVIVOSCRIBE TECHNOLOGIES, INC., SAN DIEGO, CA. SN 85-039,327. PUB. 5-17-2011, FILED 5-14-2010.

INVIVOSCRIBE

THE MARK CONSISTS OF STANDARD CHARACTERS WITHOUT CLAIM TO ANY PARTICULAR FONT, STYLE, SIZE, OR COLOR.

CLASS 1—CHEMICALS

FOR CHEMICAL AND BIOTECHNOLOGICAL PRODUCTS FOR COMMERCIAL AND SCIENTIFIC RESEARCH PURPOSES, NAMELY, REAGENTS FOR SCIENTIFIC AND RESEARCH USE, IN THE NATURE OF BUFFER SOLUTIONS, MOLECULAR PROBES, NUCLEIC ACIDS, PRIMERS FOR USE IN PCR, DNA TEMPLATES, RNA TEMPLATES; KITS FOR SCIENTIFIC AND RESEARCH USE CONTAINING BUFFER SOLUTIONS, MOLECULAR PROBES, NUCLEIC ACIDS, PRIMERS FOR USE IN PCR, DNA TEMPLATES AND RNA TEMPLATES (U.S. CLS. 1, 5, 6, 10, 26 AND 46).

FIRST USE 12-0-1999; IN COMMERCE 12-0-1999.

CLASS 5—PHARMACEUTICALS

FOR MEDICAL DIAGNOSTIC REAGENTS, NAMELY, BUFFER SOLUTIONS, MOLECULAR PROBES, NUCLEIC ACIDS, PRIMERS FOR USE IN PCR, DNA TEMPLATES, RNA TEMPLATES; MEDICAL DIAGNOSTIC KITS CONTAINING BUFFER SOLUTIONS, MOLECULAR PROBES, NUCLEIC ACIDS, PRIMERS FOR USE IN PCR, DNA TEMPLATES, RNA TEMPLATES; MEDICAL DIAGNOSTIC KITS COMPRISED OF MEDICAL DIAGNOSTIC REAGENTS FOR THE TREATMENT, MONITORING OR DIAGNOSIS OF DISEASE; MEDICAL DIAGNOSTIC KITS FOR CLINICAL OR MEDICAL USE COMPRISED OF MEDICAL DIAGNOSTIC REAGENTS; MEDICAL DIAGNOSTIC REAGENT ASSAYS FOR THE TREATMENT OR DIAGNOSIS OF DISEASE; DIAGNOSTIC ASSAYS FOR CLINICAL AND MEDICAL USE (U.S. CLS. 6, 18, 44, 46, 51 AND 52).

FIRST USE 3-0-2006; IN COMMERCE 3-0-2006.

4,119,108. INVIVOSCRIBE TECHNOLOGIES, INC., SAN DIEGO, CA. SN 85-041,503. PUB. 5-17-2011, FILED 5-18-2010.



THE MARK CONSISTS OF A RIBBON FORMED INTO THREE TEAR-DROP SHAPED LOOPS WITH THE WORD "INVIVOSCRIBE" TO THE RIGHT OF THE RIBBON.

CLASS 1—CHEMICALS

FOR CHEMICAL AND BIOTECHNOLOGICAL PRODUCTS FOR COMMERCIAL AND SCIENTIFIC RESEARCH PURPOSES, NAMELY, REAGENTS FOR SCIENTIFIC AND RESEARCH USE, IN THE NATURE OF BUFFER SOLUTIONS, MOLECULAR PROBES, NUCLEIC ACIDS, PRIMERS FOR USE IN PCR, DNA TEMPLATES, RNA TEMPLATES; KITS FOR SCIENTIFIC AND RESEARCH USE CONTAINING BUFFER SOLUTIONS, MOLECULAR PROBES, NUCLEIC ACIDS, PRIMERS FOR USE IN PCR, DNA TEMPLATES AND RNA TEMPLATES (U.S. CLS. 1, 5, 6, 10, 26 AND 46).

FIRST USE 4-0-2010; IN COMMERCE 4-0-2010.

CLASS 5—PHARMACEUTICALS

FOR MEDICAL DIAGNOSTIC REAGENTS, NAMELY, BUFFER SOLUTIONS, MOLECULAR PROBES, NUCLEIC ACIDS, PRIMERS FOR USE IN PCR, DNA TEMPLATES, RNA TEMPLATES; MEDICAL DIAGNOSTIC KITS CONTAINING BUFFER SOLUTIONS, MOLECULAR PROBES, NUCLEIC ACIDS, PRIMERS FOR USE IN PCR, DNA TEMPLATES, RNA TEMPLATES; MEDICAL DIAGNOSTIC KITS COMPRISED OF MEDICAL DIAGNOSTIC REAGENTS FOR THE TREATMENT, MONITORING OR DIAGNOSIS OF DISEASE; MEDICAL DIAGNOSTIC KITS FOR CLINICAL OR MEDICAL USE COMPRISED OF MEDICAL DIAGNOSTIC REAGENTS; MEDICAL DIAGNOSTIC REAGENT ASSAYS FOR THE TREATMENT OR DIAGNOSIS OF DISEASE; DIAGNOSTIC ASSAYS FOR CLINICAL AND MEDICAL USE (U.S. CLS. 6, 18, 44, 46, 51 AND 52).

FIRST USE 4-0-2010; IN COMMERCE 4-0-2010.

4,119,112. 4028546 CANADA INC., OAKVILLE, ONTARIO, CANADA. SN 85-044,366. PUB. 4-26-2011, FILED 5-20-2010.

IVIEW SYSTEMS

THE MARK CONSISTS OF STANDARD CHARACTERS WITHOUT CLAIM TO ANY PARTICULAR FONT, STYLE, SIZE, OR COLOR.

OWNER OF U.S. REG. NOS. 3,315,047, 3,736,995, AND OTHERS.

NO CLAIM IS MADE TO THE EXCLUSIVE RIGHT TO USE "SYSTEMS", APART FROM THE MARK AS SHOWN.

CLASS 9—ELECTRICAL AND SCIENTIFIC APPARATUS

FOR COMPUTER SOFTWARE FOR USE IN PROVIDING SECURITY AND SURVEILLANCE TO THE GAMING, BANKING, HEALTH CARE, EDUCATION AND HOSPITALITY INDUSTRIES; COMPUTER SOFTWARE FOR USE IN CONNECTION WITH THE DELIVERY OF SECURITY AND SURVEILLANCE; COMPUTER SOFTWARE FOR USE IN CONNECTION WITH THE DELIVERY OF SECURITY AND SURVEILLANCE BY MEANS OF UTILIZING SOURCE IMAGE DATABASES; COMPUTER SOFTWARE FOR USE IN PERFORMING RAPID IDENTIFICATION AND RECOGNITION OF INDIVIDUALS INVOLVED IN LOSS, THREAT CREATION AND OTHER SECURITY AND SURVEILLANCE SPECIFIC ACTIVITIES (U.S. CLS. 21, 23, 26, 36 AND 38).

FIRST USE 3-1-2002; IN COMMERCE 3-1-2002.

4,119,111. ROSENRETER, JENNIFER JAMES, CHEYENNE, WY. SN 85-043,404. PUB. 5-17-2011, FILED 5-20-2010.

WellNurse

THE MARK CONSISTS OF STANDARD CHARACTERS WITHOUT CLAIM TO ANY PARTICULAR FONT, STYLE, SIZE, OR COLOR.

CLASS 25—CLOTHING

FOR SHIRTS, NAMELY, SHORT AND LONG SLEEVE T-SHIRTS, MATERNITY SHIRTS, PLUS SIZE SHIRTS, POLO SHIRTS, ATHLETIC SHIRTS, CAMP SHIRTS, GOLF SHIRTS, KNIT SHIRTS, UNIFORM SHIRTS, TANK TOPS, MUSCLE SHIRTS; HOODED PULLOVERS, FLEECE PULLOVERS, HOODED SWEAT SHIRTS, INFANT AND TODDLER ONE PIECE CLOTHING, BABY BODYSUITS, BABY BIBS, LADIES UNDERWEAR, NAMELY, BRIEFS, PANTIES, THONGS, BOY SHORTS, G-STRINGS, BOXER SHORTS; MEN'S UNDERWEAR, NAMELY, BRIEFS, BOXER BRIEFS, BOXER SHORTS; HATS AND CAPS, NAMELY, BASEBALL CAPS, CAPS WITH VISORS, KNITTED CAPS; APRONS; SCRUB TOPS, SCRUB BOTTOMS, AND SCRUB SETS NOT FOR MEDICAL PURPOSES (U.S. CLS. 22 AND 39).

FIRST USE 1-1-2009; IN COMMERCE 12-1-2009.

CLASS 41—EDUCATION AND ENTERTAINMENT

FOR TRAINING SERVICES IN THE FIELD OF SECURITY AND SURVEILLANCE, INCIDENT REPORTING AND MANAGEMENT, INVESTIGATION MANAGEMENT, RISK ASSESSMENT AND ANALYSIS, ACTIVITY TRACKING; TRAINING IN THE USE OF SECURITY AND SURVEILLANCE SOFTWARE AND SYSTEMS (U.S. CLS. 100, 101 AND 107).

FIRST USE 3-1-2002; IN COMMERCE 3-1-2002.

CLASS 45—PERSONAL AND LEGAL SERVICES

FOR PROVIDING SECURITY AND SURVEILLANCE MONITORING SERVICES; SECURITY AND SURVEILLANCE, NAMELY, INCIDENT REPORTING, RISK ASSESSMENT, AND ANALYSIS, INVESTIGATING SECURITY THREATS AND INCIDENTS INVOLVING SECURITY THREATS TO BUSINESSES, INSTITUTIONS, GOVERNMENT INSTALLATIONS AND THE LIKE (U.S. CLS. 100 AND 101).

FIRST USE 3-1-2002; IN COMMERCE 3-1-2002.

4,119,113. MATJEK ENTERPRISES, INC., DOWNERS GROVE, IL. SN 85-044,448. PUB. 7-12-2011, FILED 5-20-2010.

CARDFRENZY**CLASS 41—EDUCATION AND ENTERTAINMENT**

FOR PROVIDING A WEBSITE FEATURING INFORMATION ABOUT EXERCISE AND FITNESS; PROVIDING ONLINE JOURNALS, NAMELY, BLOGS ABOUT HEALTH, WELLNESS, NUTRITION, EXERCISE, FITNESS, AND HEALTHCARE (U.S. CLS. 100, 101 AND 107).

FIRST USE 1-1-2009; IN COMMERCE 12-1-2009.

THE MARK CONSISTS OF STANDARD CHARACTERS

WITHOUT CLAIM TO ANY PARTICULAR FONT, STYLE, SIZE, OR COLOR.

NO CLAIM IS MADE TO THE EXCLUSIVE RIGHT TO USE "CARD", APART FROM THE MARK AS SHOWN.

CLASS 35—ADVERTISING AND BUSINESS

FOR ON-LINE RETAIL STORE SERVICES AND RETAIL STORE SERVICES FEATURING GIFTS, WRITING PAPER, GREETING CARDS, ENGAGEMENT CARDS, VISITING CARDS, INVITATION CARDS, BUSINESS CARDS, NOTEBOOKS, BOOK MARKS, PRINTS, PICTURES, PHOTOGRAPHS, PHOTOGRAPH ALBUMS, PEN AND PENCIL SETS, STATIONERY, CALENDARS, DIARIES, BLANK JOURNALS, PAPER TAGS AND LABELS, PAPER PACKAGING MATERIALS, NAMELY, CARDBOARD GIFT BOXES AND STORAGE BOXES, PAPER, FABRIC AND TEXTILE GIFT BAGS, PAPER GIFT WRAPPING RIBBONS, PAPER GIFT WRAPPING, TISSUE PAPER, NOTE CARDS, ADDRESS BOOKS, PLACE CARDS, PAPER PLATES, PAPER NAPKINS, AND TABLE CLOTHS MADE OF PAPER (U.S. CLS. 100, 101 AND 102).

FIRST USE 11-1-2010; IN COMMERCE 11-1-2010.

CLASS 40—MATERIAL TREATMENT

FOR MONOGRAMMING OF CLOTHING AND FABRICS (U.S. CLS. 100, 103 AND 106).

FIRST USE 11-1-2010; IN COMMERCE 11-1-2010.

4,119,123. EHARMONY, INC., SANTA MONICA, CA. SN 85-049,275. PUB. 11-2-2010, FILED 5-27-2010.

JAZZED

THE MARK CONSISTS OF STANDARD CHARACTERS WITHOUT CLAIM TO ANY PARTICULAR FONT, STYLE, SIZE, OR COLOR.

CLASS 42—SCIENTIFIC AND COMPUTER SERVICES

FOR COMPUTER SERVICES, NAMELY, HOSTING ONLINE WEB FACILITIES FOR ORGANIZING GATHERINGS, AND INTERACTIVE DISCUSSIONS (U.S. CLS. 100 AND 101).

FIRST USE 12-27-2011; IN COMMERCE 12-27-2011.

CLASS 45—PERSONAL AND LEGAL SERVICES

FOR DATING SERVICES, COUNSELING, NAMELY, OFFERING ADVICE REGARDING PERSONAL RELATIONSHIPS AND PERSONAL WELL BEING VIA A GLOBAL COMPUTER NETWORK; INTERNET BASED INTRODUCTION AND SOCIAL NETWORKING SERVICES; PROVIDING A WEBSITE FEATURING INFORMATION IN THE AREA OF PERSONAL RELATIONSHIP WELLNESS; PROVIDING INFORMATION IN THE FIELD OF PERSONAL RELATIONSHIP WELLNESS; PROVIDING INFORMATION IN THE FIELD OF SOCIAL INTRODUCTION (U.S. CLS. 100 AND 101).

FIRST USE 7-14-2010; IN COMMERCE 7-14-2010.

4,119,125. PORTIONPAC CHEMICAL CORPORATION, CHICAGO, IL. SN 85-050,706. PUB. 5-31-2011, FILED 5-28-2010.

PORTIONPAC

THE MARK CONSISTS OF STANDARD CHARACTERS WITHOUT CLAIM TO ANY PARTICULAR FONT, STYLE, SIZE, OR COLOR.

OWNER OF U.S. REG. NO. 808,964.

CLASS 3—COSMETICS AND CLEANING PREPARATIONS

FOR CLEANING PREPARATIONS AND DETERGENTS; DEGREASING PREPARATIONS USED IN NON-MANUFACTURING PROCESSES IN THE FIELD OF CLEANING; CARPET SHAMPOOS; UPHOLSTERY SHAMPOOS; FLOOR FINISH; FLOOR CONDITIONERS, NAMELY, NEUTRALIZERS OF OTHER CLEANING CHEMICALS AND ICE-MELTING CHEMICALS; FLOOR STRIPPING/CLEANING PREPARATIONS (U.S. CLS. 1, 4, 6, 50, 51 AND 52).

FIRST USE 1-1-1973; IN COMMERCE 1-1-1973.

CLASS 5—PHARMACEUTICALS

FOR SANITIZERS, NAMELY, CHEMICAL PREPARATIONS FOR SANITARY PURPOSES, KITCHEN EQUIPMENT SANITIZING CHEMICALS; SINK SANITIZING CHEMICALS; GERMICIDES; DEODORIZERS, NAMELY, AIR DEODORIZER AND AIR FRESHENERS; DEODORIZERS, NAMELY, FACILITY MALODOR FRESHENERS (U.S. CLS. 6, 18, 44, 46, 51 AND 52).

FIRST USE 1-1-1969; IN COMMERCE 1-1-1969.

CLASS 41—EDUCATION AND ENTERTAINMENT

FOR PROVIDING OF TRAINING AND CLASSES, SEMINARS, WORKSHOPS, IN THE AREA OF DEGREASING, CLEANING, AND SANITIZING OF FIXTURES, EQUIPMENT, FACILITIES, AND STRUCTURES (U.S. CLS. 100, 101 AND 107).

FIRST USE 1-1-1993; IN COMMERCE 1-1-1993.

4,119,132. JAKE SHIELDS, INC., ARNOLD, CA. SN 85-054,485. PUB. 1-4-2011, FILED 6-3-2010.



NO CLAIM IS MADE TO THE EXCLUSIVE RIGHT TO USE "AMERICAN JIU JITSU", APART FROM THE MARK AS SHOWN.

THE MARK CONSISTS OF AN EAGLE GRASPING A CREST WITH ARROWS AND THE WORDS "AMERICAN

JIU JITSU".

CLASS 25—CLOTHING

FOR CLOTHING, NAMELY, TEE SHIRTS, HATS, SHORTS, WARM UP SUITS, JACKETS AND MARTIAL ARTS UNIFORMS (U.S. CLS. 22 AND 39).

FIRST USE 1-15-2008; IN COMMERCE 9-30-2008.

CLASS 41—EDUCATION AND ENTERTAINMENT

FOR MARTIAL ARTS INSTRUCTION (U.S. CLS. 100, 101 AND 107).

FIRST USE 11-30-2008; IN COMMERCE 1-30-2009.

4,119,133. RICHARD D. WARREN, RANCHO SANTA MARGARITA, CA. SN 85-054,761. PUB. 3-15-2011, FILED 6-4-2010.

RADICALIS

THE MARK CONSISTS OF STANDARD CHARACTERS WITHOUT CLAIM TO ANY PARTICULAR FONT, STYLE, SIZE, OR COLOR.

CLASS 9—ELECTRICAL AND SCIENTIFIC APPARATUS

FOR PRE-RECORDED COMPACT DISCS, AND DVDS IN THE FIELD OF RELIGION AND RELIGIOUS AWARENESS AND PARTICIPATION; PRE-RECORDED COMPACT DISCS, AND DVDS FEATURING RELIGIOUS MUSIC AND SERMONS; DOWNLOADABLE AUDIO AND VIDEO RECORDINGS FEATURING SERMONS OR OTHER INFORMATION IN THE FIELD OF RELIGION AND RELIGIOUS AWARENESS AND PARTICIPATION (U.S. CLS. 21, 23, 26, 36 AND 38).

FIRST USE 2-0-2010; IN COMMERCE 2-0-2010.

CLASS 16—PAPER GOODS AND PRINTED MATTER

FOR PRINTED PUBLICATIONS AND PRINTED MATTER, NAMELY, BOOKS ALL IN THE FIELD OF RELIGION; AND PRINTED INSTRUCTIONAL, EDUCATIONAL AND TEACHING MATERIALS RELATING TO RELIGION AND INCREASING RELIGIOUS AWARENESS AND PARTICIPATION (U.S. CLS. 2, 5, 22, 23, 29, 37, 38 AND 50).

FIRST USE 2-0-2010; IN COMMERCE 2-0-2010.

CLASS 41—EDUCATION AND ENTERTAINMENT

FOR EDUCATIONAL SERVICES, NAMELY, PROVIDING SEMINARS, CONFERENCES AND INSTRUCTION IN THE FIELD OF RELIGIOUS AWARENESS AND PARTICIPATION, RELIGION AND MINISTRY; PROVIDING ON-LINE PUBLICATIONS, NAMELY, MAGAZINES, BOOKS, NEWSLETTERS, SERMONS AND PAMPHLETS IN THE FIELDS OF RELIGIOUS AWARENESS AND PARTICIPATION, RELIGION AND MINISTRY (U.S. CLS. 100, 101 AND 107).

FIRST USE 2-0-2010; IN COMMERCE 2-0-2010.

CLASS 45—PERSONAL AND LEGAL SERVICES

FOR PROVIDING ONLINE INFORMATION IN THE FIELD OF RELIGION, SPIRITUALITY, SELF-HELP AND PERSONAL EMPOWERMENT; PROVIDING ONLINE WEBSITES IN THE FIELD OF RELIGION FEATURING INFORMATION ON RELIGION, RELIGIOUS AWARENESS AND PARTICIPATION, SERMONS AND MINISTERIAL RESOURCES; PROVIDING AN ONLINE COMPUTER DATABASE IN THE FIELD OF RELIGION; MINISTRY SERVICES; AND PROVIDING WEBCASTS IN THE FIELD OF RELIGION AND MINISTRY VIA A GLOBAL COMPUTER NETWORK (U.S. CLS. 100 AND 101).

FIRST USE 2-0-2010; IN COMMERCE 2-0-2010.

4,119,135. INVIVOSCRIBE TECHNOLOGIES, INC., SAN DIEGO, CA. SN 85-055,324. PUB. 5-17-2011, FILED 6-4-2010.

LABPMM

THE MARK CONSISTS OF STANDARD CHARACTERS WITHOUT CLAIM TO ANY PARTICULAR FONT, STYLE, SIZE, OR COLOR.

CLASS 42—SCIENTIFIC AND COMPUTER SERVICES

FOR PROVIDING MEDICAL TESTING AND CONSULTATION SERVICES FOR BOTH CLINICAL RESEARCH AND RESEARCH APPLICATIONS; PERFORMING SCIENTIFIC RESEARCH SERVICES, NAMELY, THE ISOLATION, DETECTION, AND ANALYSIS OF BIOLOGICAL SUBSTANCES FROM CLINICAL SAMPLES FOR OTHERS (U.S. CLS. 100 AND 101).

FIRST USE 9-0-2007; IN COMMERCE 9-0-2007.

CLASS 44—MEDICAL, BEAUTY AND AGRICULTURAL SERVICES

FOR PROVIDING MEDICAL TESTING AND CONSULTATION SERVICES FOR CLINICAL APPLICATIONS; PERFORMING MEDICAL DIAGNOSTIC SERVICES, NAMELY, THE ISOLATION, DETECTION, AND ANALYSIS OF BIOLOGICAL SUBSTANCES FROM CLINICAL SAMPLES FOR OTHERS, PROVIDING MEDICAL TESTING AND CONSULTATION SERVICES FOR DIAGNOSTIC AND TREATMENT PURPOSES (U.S. CLS. 100 AND 101).

FIRST USE 9-0-2007; IN COMMERCE 9-0-2007.

4,119,136. INVIVOSCRIBE TECHNOLOGIES, INC., SAN DIEGO, CA. SN 85-055,465. PUB. 5-17-2011, FILED 6-4-2010.



THE MARK CONSISTS OF A HUMAN FIGURE WITH A DNA MOLECULE POSITIONED HORIZONTALLY AT

WASTE LEVEL PLUS THE WORDS, AND/OR LETTERS "LAB PMM" TO THE RIGHT OF THE FIGURE.

4,119,143. BAYVIEW ENTERTAINMENT, LLC, HACKENSACK, NJ. SN 85-058,303. PUB. 4-26-2011, FILED 6-9-2010.

CLASS 42—SCIENTIFIC AND COMPUTER SERVICES

FOR PROVIDING MEDICAL TESTING AND CONSULTATION SERVICES FOR BOTH CLINICAL RESEARCH AND RESEARCH APPLICATIONS; PERFORMING SCIENTIFIC RESEARCH SERVICES, NAMELY, THE ISOLATION, DETECTION, AND ANALYSIS OF BIOLOGICAL SUBSTANCES FROM CLINICAL SAMPLES FOR OTHERS (U.S. CLS. 100 AND 101).
FIRST USE 4-0-2010; IN COMMERCE 4-0-2010.

CLASS 44—MEDICAL, BEAUTY AND AGRICULTURAL SERVICES

FOR PROVIDING MEDICAL TESTING AND CONSULTATION SERVICES FOR CLINICAL APPLICATIONS; PERFORMING MEDICAL DIAGNOSTIC SERVICES, NAMELY, THE ISOLATION, DETECTION, AND ANALYSIS OF BIOLOGICAL SUBSTANCES FROM CLINICAL SAMPLES FOR OTHERS, PROVIDING MEDICAL TESTING AND CONSULTATION SERVICES FOR DIAGNOSTIC AND TREATMENT PURPOSES (U.S. CLS. 100 AND 101).
FIRST USE 4-0-2010; IN COMMERCE 4-0-2010.

4,119,141. ALSCO INC., SALT LAKE CITY, UT. SN 85-058,224. PUB. 11-2-2010, FILED 6-9-2010.

HealthAssure

THE MARK CONSISTS OF STANDARD CHARACTERS WITHOUT CLAIM TO ANY PARTICULAR FONT, STYLE, SIZE, OR COLOR.

CLASS 35—ADVERTISING AND BUSINESS

FOR RETAIL STORE SERVICES AND ONLINE RETAIL STORE SERVICES FEATURING UNIFORMS, CLOTHES, HOSPITAL AND HEALTHCARE GARMENTS, LINENS, RUGS, FABRICS, GLOVES, FLOOR MATS, WIPERS, SHOE COVERS, CAPS AND MASKS, WET AND DRY MOPS, DUST CONTROL PRODUCTS, PAPER PRODUCTS, WASHROOM SUPPLIES, CHEMICALS AND SOAPS (U.S. CLS. 100, 101 AND 102).
FIRST USE 2-28-2011; IN COMMERCE 2-28-2011.

CLASS 37—CONSTRUCTION AND REPAIR

FOR PROVIDING LAUNDERING SERVICES FOR UNIFORMS, HOSPITAL AND HEALTHCARE GARMENTS, CLOTHES, LINENS, MATS, RUGS AND FABRICS TO HEALTHCARE PROVIDERS; RENTAL OF WET AND DRY MOPS; REPAIR OF UNIFORMS, HOSPITAL AND HEALTHCARE GARMENTS, CLOTHES, LINENS, RUGS AND FABRICS; RENTAL OF CLEANING EQUIPMENT, NAMELY, HYGIENE PRODUCTS FOR WASHROOMS AND RESTROOMS (U.S. CLS. 100, 103 AND 106).
FIRST USE 2-28-2011; IN COMMERCE 2-28-2011.

CLASS 45—PERSONAL AND LEGAL SERVICES

FOR RENTAL OF UNIFORMS, HOSPITAL AND HEALTHCARE GARMENTS, CLOTHING, HATS AND SMOCKS (U.S. CLS. 100 AND 101).
FIRST USE 2-28-2011; IN COMMERCE 2-28-2011.

BAYVIEW

THE MARK CONSISTS OF STANDARD CHARACTERS WITHOUT CLAIM TO ANY PARTICULAR FONT, STYLE, SIZE, OR COLOR.

OWNER OF U.S. REG. NO. 3,862,558.

CLASS 9—ELECTRICAL AND SCIENTIFIC APPARATUS

FOR DIGITAL MEDIA, NAMELY, PRE-RECORDED VIDEO CASSETTES, DIGITAL VIDEO DISCS, DIGITAL VERSATILE DISCS, DOWNLOADABLE AUDIO AND VIDEO RECORDINGS, DVDS, AND HIGH DEFINITION DIGITAL DISCS, FEATURING ANIMATED PERFORMANCES, CHILDREN'S ENTERTAINMENT, FITNESS INSTRUCTION, ANIMAL TRAINING INSTRUCTION, MARTIAL ARTS INSTRUCTION, DANCE INSTRUCTION, WELLNESS AND HEALTH INSTRUCTION; DOWNLOADABLE PODCASTS IN THE FIELD OF CHILDREN'S ENTERTAINMENT, FITNESS INSTRUCTION, ANIMAL TRAINING INSTRUCTION, MARTIAL ARTS INSTRUCTION, DANCE INSTRUCTION, WELLNESS AND HEALTH INSTRUCTION (U.S. CLS. 21, 23, 26, 36 AND 38).
FIRST USE 3-28-2005; IN COMMERCE 3-28-2005.

CLASS 41—EDUCATION AND ENTERTAINMENT

FOR PRODUCTION AND DISTRIBUTION OF VIDEOS IN THE FIELD OF ANIMATED PERFORMANCES, CHILDREN'S ENTERTAINMENT, FITNESS INSTRUCTION, MARTIAL ARTS INSTRUCTION, DANCE INSTRUCTION, WELLNESS AND HEALTH INSTRUCTION; ENTERTAINMENT SERVICES, NAMELY, PROVIDING PODCASTS IN THE FIELD OF CHILDREN'S ENTERTAINMENT, FITNESS INSTRUCTION, MARTIAL ARTS INSTRUCTION, DANCE INSTRUCTION, WELLNESS AND HEALTH INSTRUCTION (U.S. CLS. 100, 101 AND 107).
FIRST USE 3-28-2005; IN COMMERCE 3-28-2005.

4,119,166. PARTNERSHIP FOR A DRUG FREE AMERICA, INC., NEW YORK, NY. SN 85-069,944. PUB. 5-24-2011, FILED 6-23-2010.

THE PARTNERSHIP AT DRUGFREE.ORG

OWNER OF U.S. REG. NO. 1,763,443.

NO CLAIM IS MADE TO THE EXCLUSIVE RIGHT TO USE "DRUGFREE.ORG", APART FROM THE MARK AS SHOWN.

THE MARK CONSISTS OF THE TEXT "THE PARTNERSHIP AT DRUGFREE.ORG" WITH AN UNDERLINE POSITIONED UNDERNEATH THE TEXT.

CLASS 9—ELECTRICAL AND SCIENTIFIC APPARATUS

FOR DOWNLOADABLE ELECTRONIC PUBLICATIONS IN THE NATURE OF BROCHURES, FLYERS, NEWSLETTERS, AND WALLET CARDS IN THE FIELD OF SUBSTANCE ABUSE EDUCATION (U.S. CLS. 21, 23, 26, 36 AND 38).

FIRST USE 10-31-2010; IN COMMERCE 10-31-2010.

CLASS 16—PAPER GOODS AND PRINTED MATTER

FOR PUBLICATIONS, NAMELY, BROCHURES, FLYERS, NEWSLETTERS, AND WALLET CARDS IN THE FIELD OF SUBSTANCE ABUSE EDUCATION (U.S. CLS. 2, 5, 22, 23, 29, 37, 38 AND 50).

FIRST USE 11-30-2010; IN COMMERCE 11-30-2010.

CLASS 35—ADVERTISING AND BUSINESS

FOR PROMOTING PUBLIC AWARENESS OF THE NEED FOR SOUND PRACTICES AIMED AT PREVENTION AND EARLY INTERVENTION OF DRUG AND ALCOHOL ABUSE; PROMOTING PUBLIC AWARENESS OF THE NEED TO CREATE A DRUG-FREE SOCIETY; PRODUCTION OF PUBLIC SERVICE ANNOUNCEMENTS (U.S. CLS. 100, 101 AND 102).

FIRST USE 7-26-2010; IN COMMERCE 7-26-2010.

CLASS 41—EDUCATION AND ENTERTAINMENT

FOR PROVIDING A WEBSITE FEATURING INFORMATION RELATING TO EDUCATIONAL SERVICES OFFERED IN THE FIELD OF SUBSTANCE ABUSE EDUCATION (U.S. CLS. 100, 101 AND 107).

FIRST USE 10-31-2010; IN COMMERCE 10-31-2010.

CLASS 44—MEDICAL, BEAUTY AND AGRICULTURAL SERVICES

FOR ASSISTING PARENTS IN PREVENTING, INTERVENING AND FINDING TREATMENT FOR DRUG AND ALCOHOL USE BY THEIR CHILDREN; PROVIDING RECOVERY SUPPORT SERVICES FOR DRUG AND ALCOHOL ABUSE; PROVIDING A WEBSITE FEATURING EDUCATIONAL INFORMATION IN THE FIELD OF SUBSTANCE ABUSE (U.S. CLS. 100 AND 101).

FIRST USE 3-24-2011; IN COMMERCE 3-24-2011.

CLASS 25—CLOTHING

FOR MEN'S, WOMEN'S AND CHILDREN'S CLOTHING, NAMELY, T-SHIRTS; CHILDREN'S CLOTHING, NAMELY, ONE PIECE GARMENTS (U.S. CLS. 22 AND 39).

FIRST USE 1-4-2012; IN COMMERCE 1-4-2012.

4,119,184. CISCO TECHNOLOGY, INC., SAN JOSE, CA. SN 85-077,581. PUB. 11-23-2010, FILED 7-2-2010.

**CISCO COLLABORATION
BREAKAWAY**

THE MARK CONSISTS OF STANDARD CHARACTERS WITHOUT CLAIM TO ANY PARTICULAR FONT, STYLE, SIZE, OR COLOR.

OWNER OF U.S. REG. NOS. 3,070,991, 3,759,451, AND OTHERS.

CLASS 35—ADVERTISING AND BUSINESS

FOR ADMINISTRATION OF A PROGRAM FOR ENABLING PARTICIPANTS TO OBTAIN DISCOUNTS ON PRODUCTS AND SERVICES (U.S. CLS. 100, 101 AND 102).

FIRST USE 8-9-2010; IN COMMERCE 8-9-2010.

CLASS 36—INSURANCE AND FINANCIAL

FOR FINANCING SERVICES (U.S. CLS. 100, 101 AND 102).

FIRST USE 8-9-2010; IN COMMERCE 8-9-2010.

4,119,168. ZBABIES, LLC, FOND DU LAC, WI. SN 85-071,518. PUB. 11-23-2010, FILED 6-25-2010.

LITTLE LEGENDS

THE MARK CONSISTS OF STANDARD CHARACTERS WITHOUT CLAIM TO ANY PARTICULAR FONT, STYLE, SIZE, OR COLOR.

CLASS 21—HOUSEWARES AND GLASS

FOR MUGS (U.S. CLS. 2, 13, 23, 29, 30, 33, 40 AND 50).

FIRST USE 1-4-2012; IN COMMERCE 1-4-2012.

4,119,185. JAM INDUSTRIES LTD./LTEE, QUEBEC H9X 4B7, CANADA. SN 85-079,466. PUB. 9-6-2011, FILED 7-7-2010.

JAY J

THE MARK CONSISTS OF STANDARD CHARACTERS WITHOUT CLAIM TO ANY PARTICULAR FONT, STYLE, SIZE, OR COLOR.

CLASS 9—ELECTRICAL AND SCIENTIFIC APPARATUS

FOR AMPLIFIERS; AUDIO SPEAKERS, CABINETS FOR AUDIO SPEAKERS; ENCLOSURES FOR AUDIO SPEAKERS; SOUND AMPLIFIERS; SOUND PRE-AMPLIFIERS; SOUND PROCESSING AND MODIFYING DEVICES, NAMELY, DELAY, REVERB AND DISTORTION EFFECT UNITS FOR MODIFYING SOUND; ELECTRICAL OR BATTERY-POWERED SOUND PROCESSING DEVICES THAT INCREASE AMPLITUDE OR LOUDNESS OF MUSICAL INSTRUMENTS OR INPUT SIGNALS VIA MICROPHONE OR LOUDSPEAKER; INTERFACES FOR CONNECTION OF ELECTRONIC SOUND EQUIPMENT; HOME RECORDING DEVICES, NAMELY, DIGITAL HARD DRIVES FOR ELECTRONIC SOUND EQUIPMENT AND MAGNETIC TAPE RECORDERS, SIGNAL PROCESSORS FOR SOUND RECORDING; MICROPHONES, CABLES FOR CONNECTING ELECTRONIC SOUND EQUIPMENT, SOUND MIXING BOARDS, ELECTRONIC REFERENCE MONITORS, LOUDSPEAKERS, ELECTRONIC SOUND AMPLIFIERS; VOCAL TRAINERS, NAMELY, VOCAL AND HARMONY PROCESSORS; BAGS AND CASES FOR ELECTRONIC SOUND EQUIPMENT; STANDS FOR MICROPHONES AND LOUDSPEAKERS (U.S. CLS. 21, 23, 26, 36 AND 38).
FIRST USE 1-0-2007; IN COMMERCE 1-0-2007.

CLASS 15—MUSICAL INSTRUMENTS

FOR MUSICAL INSTRUMENTS, NAMELY, ELECTRIC AND ACOUSTIC GUITARS, BANJOS, MANDOLINS, UKULELES; ACCESSORIES FOR GUITARS, NAMELY, GUITAR PICKS, SLIDES AND CAPOS; MUSICAL INSTRUMENT BAGS AND CASES; STRAPS FOR MUSICAL INSTRUMENTS; STANDS FOR MUSICAL INSTRUMENTS AND SHEET MUSIC (U.S. CLS. 2, 21 AND 36).
FIRST USE 1-0-2007; IN COMMERCE 1-0-2007.

4,119,189. MARK JONATHAN DAVIS, PASADENA, CA. SN 85-081,736. PUB. 12-14-2010, FILED 7-9-2010.

JOHNNY ALOHA

THE MARK CONSISTS OF STANDARD CHARACTERS WITHOUT CLAIM TO ANY PARTICULAR FONT, STYLE, SIZE, OR COLOR.

THE NAME(S), PORTRAIT(S), AND/OR SIGNATURE(S) SHOWN IN THE MARK IDENTIFIES THE STAGE NAME OF THE APPLICANT, MARK DAVIS, A LIVING INDIVIDUAL, WHOSE CONSENT(S) TO REGISTER IS MADE OF RECORD.

CLASS 9—ELECTRICAL AND SCIENTIFIC APPARATUS

FOR DOWNLOADABLE MUSICAL SOUND RECORDINGS; MUSICAL SOUND RECORDINGS (U.S. CLS. 21, 23, 26, 36 AND 38).
FIRST USE 4-14-2010; IN COMMERCE 4-14-2010.

CLASS 41—EDUCATION AND ENTERTAINMENT

FOR ENTERTAINMENT SERVICES IN THE NATURE OF LIVE MUSICAL PERFORMANCES; ENTERTAINMENT SERVICES, NAMELY, LIVE, TELEVISED AND MOVIE APPEARANCES BY A PROFESSIONAL ENTERTAINER; ENTERTAINMENT, NAMELY, LIVE PERFORMANCES BY A MUSICAL BAND (U.S. CLS. 100, 101 AND 107).
FIRST USE 4-14-2010; IN COMMERCE 4-14-2010.

4,119,192. ALLEGHENY VALLEY BASEBALL CLUB, INC., PITTSBURGH, PA. SN 85-083,364. PUB. 7-5-2011, FILED 7-13-2010.

"IT'S YOUR PERFECT PITCH!"

THE MARK CONSISTS OF STANDARD CHARACTERS WITHOUT CLAIM TO ANY PARTICULAR FONT, STYLE, SIZE, OR COLOR.

CLASS 16—PAPER GOODS AND PRINTED MATTER

FOR PRINTED MATTER, NAMELY, NEWSPAPERS AND PERIODICAL PUBLICATIONS, MAGAZINES, AND BOOKS IN THE FIELD OF BASEBALL; POSTCARDS; PRINTED TICKETS; BOOKLETS FEATURING BASEBALL; STICKERS; ENVELOPES; AND PRINTED INSTRUCTIONAL AND TEACHING MATERIALS IN THE FIELD OF PLAYING THE GAME OF BASEBALL (U.S. CLS. 2, 5, 22, 23, 29, 37, 38 AND 50).
FIRST USE 9-3-2009; IN COMMERCE 9-3-2009.

CLASS 41—EDUCATION AND ENTERTAINMENT

FOR EDUCATIONAL AND TRAINING SERVICES, NAMELY, CONDUCTING COURSES, CLASSES, SEMINARS, WORKSHOPS, CONFERENCES AND SYMPOSIUMS FEATURING TRAINING IN PLAYING THE GAME OF BASEBALL AND CONSULTATION RELATED THEREWITH (U.S. CLS. 100, 101 AND 107).
FIRST USE 9-3-2009; IN COMMERCE 9-3-2009.

4,119,206. TERRENO RESOURCES CORP., VANCOUVER, BC, CANADA. SN 85-090,925. PUB. 6-28-2011, FILED 7-22-2010.

TERRENO

THE MARK CONSISTS OF STANDARD CHARACTERS WITHOUT CLAIM TO ANY PARTICULAR FONT, STYLE, SIZE, OR COLOR.

PRIORITY CLAIMED UNDER SEC. 44(D) ON CANADA APPLICATION NO. 1489557, FILED 7-21-2010.

THE ENGLISH TRANSLATION OF "TERRENO" FROM SPANISH IN THE MARK IS LAND.

CLASS 37—CONSTRUCTION AND REPAIR

FOR OPERATION OF A NATURAL RESOURCES MINING EXTRACTION SERVICES IN THE HARD METALS, PRECIOUS METALS, RARE EARTH MINERALS, WATER, GAS AND OIL SECTORS (U.S. CLS. 100, 103 AND 106).
FIRST USE 7-21-2010; IN COMMERCE 7-21-2010.

CLASS 42—SCIENTIFIC AND COMPUTER SERVICES

FOR OPERATION OF A NATURAL MINING EXPLORATION AND MINERAL EXPLORATION SERVICES IN THE HARD METALS, PRECIOUS METALS, RARE EARTH MINERALS, WATER, GAS AND OIL SECTORS (U.S. CLS. 100 AND 101).

FIRST USE 7-21-2010; IN COMMERCE 7-21-2010.

4,119,231. ARE YOU DENSE, INC., WOODBURY, CT. SN 85-107,468. PUB. 5-24-2011, FILED 8-13-2010.



4,119,207. ENGINE, LLC, GLEN ELLYN, IL. SN 85-091,370. PUB. 3-1-2011, FILED 7-23-2010.

Engine Direct

THE MARK CONSISTS OF STANDARD CHARACTERS WITHOUT CLAIM TO ANY PARTICULAR FONT, STYLE, SIZE, OR COLOR.

NO CLAIM IS MADE TO THE EXCLUSIVE RIGHT TO USE "DIRECT", APART FROM THE MARK AS SHOWN.

CLASS 35—ADVERTISING AND BUSINESS

FOR MARKETING CONSULTING AND MARKETING PLAN DEVELOPMENT SERVICES IN THE FIELD OF BUSINESS DEVELOPMENT: BUSINESS DEVELOPMENT SERVICES IN THE FIELDS OF PRODUCT INNOVATION, MARKETING STRATEGY, ADVERTISING, CUSTOMER ACQUISITION, CUSTOMER RETENTION, CUSTOMER SERVICE, OPERATIONS AND CROSS-SELL OPERATIONAL CAPABILITIES; BUSINESS CONSULTATION SERVICES IN THE FIELDS OF PRODUCT INNOVATION, MARKETING STRATEGY, ADVERTISING, CUSTOMER ACQUISITION, CUSTOMER RETENTION, CUSTOMER SERVICE, OPERATIONS AND CROSS-SELL OPERATIONAL CAPABILITIES; ADVERTISING, MARKETING AND PROMOTION SERVICES IN THE FIELDS OF PRODUCT INNOVATION, MARKETING STRATEGY, ADVERTISING, CUSTOMER ACQUISITION, CUSTOMER RETENTION, CUSTOMER SERVICE, OPERATIONS AND CROSS-SELL OPERATIONAL CAPABILITIES (U.S. CLS. 100, 101 AND 102).

FIRST USE 12-14-2009; IN COMMERCE 12-20-2011.

CLASS 45—PERSONAL AND LEGAL SERVICES

FOR FRAUD AND IDENTITY THEFT PROTECTION SERVICES, FOR BUSINESSES AND INDIVIDUALS (U.S. CLS. 100 AND 101).

FIRST USE 12-14-2009; IN COMMERCE 12-14-2009.

THE MARK CONSISTS OF THE WORDS "ARE YOU DENSE? EXPOSING THE BEST-KEPT SECRET" WITH A RIBBON REPRESENTING THE "Y" IN THE WORD "YOU".

CLASS 16—PAPER GOODS AND PRINTED MATTER

FOR PRINTED EDUCATIONAL MATERIALS, NAMELY, BROCHURES, FACT SHEETS, AND BOOKMARKS ABOUT BREAST CANCER AND DENSE BREAST TISSUE (U.S. CLS. 2, 5, 22, 23, 29, 37, 38 AND 50).

FIRST USE 10-15-2005; IN COMMERCE 12-31-2006.

CLASS 25—CLOTHING

FOR CLOTHING, NAMELY, T-SHIRTS (U.S. CLS. 22 AND 39).

FIRST USE 8-27-2011; IN COMMERCE 12-31-2011.

CLASS 35—ADVERTISING AND BUSINESS

FOR ASSOCIATION SERVICES, NAMELY, PROMOTING THE PUBLIC INTEREST AND AWARENESS OF BREAST CANCER AND DENSE BREAST TISSUE FOR THE PURPOSES OF EARLY BREAST CANCER DETECTION, RESEARCH AND EDUCATION (U.S. CLS. 100, 101 AND 102).

FIRST USE 10-15-2005; IN COMMERCE 11-24-2009.

CLASS 36—INSURANCE AND FINANCIAL

FOR CHARITABLE FUNDRAISING SERVICES, NAMELY, ORGANIZING AND CONDUCTING FUNDRAISING EVENTS TO PROMOTE AWARENESS OF BREAST CANCER AND DENSE BREAST TISSUE FOR THE PURPOSES OF EARLY BREAST CANCER DETECTION, RESEARCH AND EDUCATION (U.S. CLS. 100, 101 AND 102).

FIRST USE 8-27-2011; IN COMMERCE 8-27-2011.

CLASS 44—MEDICAL, BEAUTY AND AGRICULTURAL SERVICES

FOR PROVIDING A WEBSITE VIA A GLOBAL COMPUTER NETWORK FEATURING MEDICAL INFORMATION IN THE FIELD OF BREAST CANCER AND DENSE BREAST TISSUE FOR THE PURPOSES OF EARLY BREAST CANCER DETECTION (U.S. CLS. 100 AND 101).

FIRST USE 10-30-2008; IN COMMERCE 10-30-2008.

4,119,236. THINKINGIQ LLC, HIGHLANDS RANCH, CO. SN 85-110,851. PUB. 5-10-2011, FILED 8-18-2010.

ThinkingIQ

THE MARK CONSISTS OF STANDARD CHARACTERS WITHOUT CLAIM TO ANY PARTICULAR FONT, STYLE, SIZE, OR COLOR.

CLASS 16—PAPER GOODS AND PRINTED MATTER

FOR EDUCATIONAL PUBLICATIONS, NAMELY, BOOKS, HAND-OUTS, WORKBOOKS, JOURNALS, PLAYBOOKS, WORKSHEETS AND CARDS IN THE FIELD OF RIGHT-BRAIN FITNESS; EDUCATIONAL PUBLICATIONS, NAMELY, EDUCATIONAL LEARNING CARDS, FLASH CARDS, ACTIVITY CARDS, WORKBOOKS, TEXTBOOKS, ACTIVITY BOOKS, STORY BOOKS, PUZZLE BOOKS, PRINTED PUZZLES, TEACHER GUIDES, MANUALS, POSTERS AND EDUCATIONAL BOOKLETS IN THE FIELDS OF ACADEMIC, PRACTICAL, EMOTIONAL AND SOCIAL ENRICHMENT, NAMELY, PROBLEM-SOLVING, CREATIVITY AND VERBAL EXPRESSION (U.S. CLS. 2, 5, 22, 23, 29, 37, 38 AND 50).

FIRST USE 11-30-2011; IN COMMERCE 11-30-2011.

CLASS 35—ADVERTISING AND BUSINESS

FOR ON-LINE RETAIL STORE SERVICES FEATURING BOARD AND CARD GAMES, PRINTED EDUCATIONAL MATERIALS THAT DEVELOP PERSONAL GROWTH, PROVIDE ACADEMIC, PRACTICAL, EMOTIONAL AND SOCIAL ENRICHMENT, CREATIVE THINKING AND PROBLEM SOLVING SKILLS, LOGIC AND MATH SKILLS (U.S. CLS. 100, 101 AND 102).

FIRST USE 4-0-2011; IN COMMERCE 4-0-2011.

4,119,237. SMITH INTERNATIONAL, INC., HOUSTON, TX. SN 85-112,583. PUB. 10-18-2011, FILED 8-20-2010.

FALCON

THE MARK CONSISTS OF STANDARD CHARACTERS WITHOUT CLAIM TO ANY PARTICULAR FONT, STYLE, SIZE, OR COLOR.

CLASS 7—MACHINERY

FOR OIL FIELD MECHANICAL ASSEMBLIES, NAMELY, MECHANICAL ASSEMBLIES FOR MULTI-STAGE FRACTURING OF SUBSURFACE GEOLOGIC FORMATIONS TO ENHANCE WELL PRODUCTION (U.S. CLS. 13, 19, 21, 23, 31, 34 AND 35).

FIRST USE 8-14-2010; IN COMMERCE 8-14-2010.

CLASS 37—CONSTRUCTION AND REPAIR

FOR OIL AND GAS EXTRACTION SERVICES, NAMELY, MULTI-STAGE FRACTURING OF SUBSURFACE GEOLOGIC FORMATIONS TO ENHANCE WELL PRODUCTION (U.S. CLS. 100, 103 AND 106).

FIRST USE 8-14-2010; IN COMMERCE 8-14-2010.

4,119,240. 52 BLOCKS INC., NEW YORK, NY. SN 85-115,274. PUB. 2-8-2011, FILED 8-25-2010.

LET'S GO DEFENSE

THE MARK CONSISTS OF STANDARD CHARACTERS WITHOUT CLAIM TO ANY PARTICULAR FONT, STYLE, SIZE, OR COLOR.

CLASS 25—CLOTHING

FOR HATS; JACKETS; PANTS; SHIRTS; SHOES; SHORTS; SWEAT SHIRTS; UNDERWEAR (U.S. CLS. 22 AND 39).

FIRST USE 12-0-2011; IN COMMERCE 12-0-2011.

CLASS 28—TOYS AND SPORTING GOODS

FOR BALLS FOR SPORTS; BASEBALL BATS; BASEBALL MITTS; TRAINING APPARATUS FOR BOXING, MARTIAL ARTS, AND SIMILAR SPORTS (U.S. CLS. 22, 23, 38 AND 50).

FIRST USE 12-0-2011; IN COMMERCE 12-0-2011.

4,119,243. AFFINION PUBLISHING, LLC, LAS VEGAS, NV. SN 85-119,969. PUB. 5-10-2011, FILED 8-31-2010.



THE MARK CONSISTS OF ONE SQUARE MADE UP OF SMALLER SQUARES THAT ARE CONFIGURED TO FORM THE LETTER "T" AND APPEARS TO THE LEFT OF THE WORDING "TRACEMYID".

CLASS 35—ADVERTISING AND BUSINESS

FOR PROVIDING CREDIT CARD REGISTRATION SERVICES IN THE NATURE OF CREDIT CARD CANCELLATION SERVICES FOR LOST OR STOLEN CARDS AND NOTIFICATION SERVICES TO CREDIT CARD ISSUERS; ASSISTANCE IN REMOVAL OF IDENTIFIABLE INFORMATION FROM INTERNET DIRECTORIES, NAMELY, PROVIDING ON-LINE COMMERCIAL DIRECTORY INFORMATION INFORMING CONSUMERS OF PHONE NUMBERS AND ADDRESSES TO REQUEST REMOVAL OF UNWANTED PERSONAL INFORMATION FROM THE WEBSITES OF OTHERS; PROVIDE INFORMATION AND ALERTS TO CONSUMERS IN THE FIELD OF FOOD AND DRUG ADMINISTRATION PRODUCT RECALLS (U.S. CLS. 100, 101 AND 102).

FIRST USE 10-15-2010; IN COMMERCE 10-15-2010.

CLASS 36—INSURANCE AND FINANCIAL

FOR PROVIDING IDENTITY THEFT INSURANCE UNDERWRITTEN BY OTHER COMPANIES (U.S. CLS. 100, 101 AND 102).

FIRST USE 10-15-2010; IN COMMERCE 10-15-2010.

CLASS 42—SCIENTIFIC AND COMPUTER SERVICES

FOR PROVIDING TEMPORARY USE OF NON-DOWNLOADABLE SOFTWARE THAT IDENTIFIES SEX OFFENDERS IN A SPECIFIED AREA AND PROVIDES ALERTS TO CONSUMERS WHEN NEW SEX OFFENDERS ARE REGISTERED IN THOSE SPECIFIED AREAS (U.S. CLS. 100 AND 101).

FIRST USE 10-15-2010; IN COMMERCE 10-15-2010.

CLASS 45—PERSONAL AND LEGAL SERVICES

FOR MONITORING INTERNET WEB SITES, MESSAGE BOARD FORUMS, INTERNET RELAY CHAT ROOMS, BLOGS AND OTHER ONLINE LOCATIONS FOR PERSONAL IDENTITY INFORMATION AND CREDIT AND DEBIT CARD NUMBERS, AND PROVIDING ALERTS AS TO ANY COMPROMISED INFORMATION OR ANY CHANGES THEREIN; CONSULTATION IN THE FIELD OF IDENTITY THEFT PROVIDED BY TELEPHONE, EMAIL, AND ON-LINE VIA THE INTERNET, IN THE FIELD OF DETECTING AND PREVENTING DAMAGE CAUSED BY IDENTITY THEFT AND DAMAGE TO CREDIT HISTORY; MONITORING OF INTERNET WEBSITES AND INDIVIDUAL CONSUMER'S CREDIT REPORTS FOR POTENTIAL THEFT AND MISUSE OF CREDIT CARD OR OTHER PERSONAL INFORMATION FOR FRAUD DETECTION AND PREVENTION PURPOSES; FINANCIAL IDENTITY MONITORING SERVICES, NAMELY, PROVIDING PUBLIC RECORDS MONITORING SERVICES; IDENTITY THEFT CONSULTATION SERVICES PROVIDING ASSISTANCE WITH SETTING FRAUD ALERTS OR SECURITY FREEZES AT CREDIT REPORTING AGENCIES; ELECTRONIC MONITORING SERVICES FOR SECURITY PURPOSES IN THE FIELD OF CREDIT CARDS AND CREDIT CARD INFORMATION; SUPPORT SERVICES PROVIDED BY E-MAIL AND ON-LINE VIA THE INTERNET IN THE FIELD OF IDENTITY THEFT RECOVERY, NAMELY, STEP-BY-STEP INSTRUCTIONS AND GUIDANCE FOR RESOLUTION OF IDENTITY THEFT CLAIMS, NON-DOWNLOADABLE SAMPLE CORRESPONDENCE FOR RESOLUTION OF IDENTITY THEFT CLAIMS; PROVIDING A WEBSITE FEATURING INFORMATION ABOUT IDENTITY THEFT RECOVERY AND RECOVERY FROM IDENTITY FRAUD AND IDENTITY MANIPULATION; CONSULTATION IN THE FIELD OF IDENTITY THEFT, NAMELY, PROVIDING PROTECTION AND ASSISTANCE IN THE EVENT OF A THEFT OF IDENTITY OR IDENTITY MANIPULATION, OR LOST OR STOLEN CREDIT CARD, DRIVERS LICENSES, PASSPORTS, AIRLINE TICKETS AND OTHER PERSONAL IDENTITY DOCUMENTS AND PUBLIC RECORDS (U.S. CLS. 100 AND 101).

FIRST USE 10-15-2010; IN COMMERCE 10-15-2010.

CLASS 35—ADVERTISING AND BUSINESS

FOR PROVIDING CREDIT CARD REGISTRATION SERVICES IN THE NATURE OF CREDIT CARD CANCELLATION SERVICES FOR LOST OR STOLEN CARDS AND NOTIFICATION SERVICES TO CREDIT CARD ISSUERS; ASSISTANCE IN REMOVAL OF IDENTIFIABLE INFORMATION FROM INTERNET DIRECTORIES, NAMELY, PROVIDING ON-LINE COMMERCIAL DIRECTORY INFORMATION INFORMING CONSUMERS OF PHONE NUMBERS AND ADDRESSES TO REQUEST REMOVAL OF UNWANTED PERSONAL INFORMATION FROM THE WEBSITES OF OTHERS; PROVIDE INFORMATION AND ALERTS TO CONSUMERS IN THE FIELD OF FOOD AND DRUG ADMINISTRATION PRODUCT RECALLS (U.S. CLS. 100, 101 AND 102).

FIRST USE 10-15-2010; IN COMMERCE 10-15-2010.

CLASS 36—INSURANCE AND FINANCIAL

FOR PROVIDING IDENTITY THEFT INSURANCE UNDERWRITTEN BY OTHER COMPANIES (U.S. CLS. 100, 101 AND 102).

FIRST USE 10-15-2010; IN COMMERCE 10-15-2010.

CLASS 42—SCIENTIFIC AND COMPUTER SERVICES

FOR PROVIDING TEMPORARY USE OF NON-DOWNLOADABLE SOFTWARE THAT IDENTIFIES SEX OFFENDERS IN A SPECIFIED AREA AND PROVIDES ALERTS TO CONSUMERS WHEN NEW SEX OFFENDERS ARE REGISTERED IN THOSE SPECIFIED AREAS (U.S. CLS. 100 AND 101).

FIRST USE 10-15-2010; IN COMMERCE 10-15-2010.

CLASS 45—PERSONAL AND LEGAL SERVICES

FOR MONITORING INTERNET WEB SITES, MESSAGE BOARD FORUMS, INTERNET RELAY CHAT ROOMS, BLOGS AND OTHER ONLINE LOCATIONS FOR PERSONAL IDENTITY INFORMATION AND CREDIT AND DEBIT CARD NUMBERS, AND PROVIDING ALERTS AS TO ANY COMPROMISED INFORMATION OR ANY CHANGES THEREIN; CONSULTATION IN THE FIELD OF IDENTITY THEFT PROVIDED BY TELEPHONE, EMAIL, AND ON-LINE VIA THE INTERNET, IN THE FIELD OF DETECTING AND PREVENTING DAMAGE CAUSED BY IDENTITY THEFT AND DAMAGE TO CREDIT HISTORY; MONITORING OF INTERNET WEBSITES AND INDIVIDUAL CONSUMER'S CREDIT REPORTS FOR POTENTIAL THEFT AND MISUSE OF CREDIT CARD OR OTHER PERSONAL INFORMATION FOR FRAUD DETECTION AND PREVENTION PURPOSES; FINANCIAL IDENTITY MONITORING SERVICES, NAMELY, PROVIDING PUBLIC RECORDS MONITORING SERVICES; IDENTITY THEFT CONSULTATION SERVICES PROVIDING ASSISTANCE WITH SETTING FRAUD ALERTS OR SECURITY FREEZES AT CREDIT REPORTING AGENCIES; ELECTRONIC MONITORING SERVICES FOR SECURITY PURPOSES IN THE FIELD OF CREDIT CARDS AND CREDIT CARD INFORMATION; SUPPORT SERVICES PROVIDED BY E-MAIL AND ON-LINE VIA THE INTERNET IN THE FIELD OF IDENTITY THEFT RECOVERY, NAMELY, STEP-BY-STEP INSTRUCTIONS AND GUIDANCE FOR RESOLUTION OF IDENTITY THEFT CLAIMS, NON-DOWNLOADABLE SAMPLE CORRESPONDENCE FOR RESOLUTION OF IDENTITY THEFT CLAIMS; PROVIDING A WEBSITE FEATURING INFORMATION ABOUT IDENTITY THEFT RECOVERY AND RECOVERY FROM IDENTITY FRAUD AND IDENTITY MANIPULATION; CONSULTATION IN THE FIELD OF IDENTITY THEFT, NAMELY, PROVIDING PROTECTION AND ASSISTANCE IN THE EVENT OF A THEFT OF IDENTITY OR IDENTITY MANIPULATION, OR LOST OR STOLEN CREDIT CARD, DRIVERS LICENSES, PASSPORTS, AIRLINE TICKETS AND OTHER PERSONAL IDENTITY DOCUMENTS AND PUBLIC RECORDS (U.S. CLS. 100 AND 101).

FIRST USE 10-15-2010; IN COMMERCE 10-15-2010.

4,119,244. AFFINION PUBLISHING, LLC, LAS VEGAS, NV.
SN 85-119,997. PUB. 5-10-2011, FILED 8-31-2010.



THE MARK CONSISTS OF ONE SQUARE MADE UP OF SMALLER SQUARES THAT ARE CONFIGURED TO FORM THE LETTER "T" AND APPEARS TO THE LEFT OF THE WORDING "TRACEMYID TAKE CONTROL OF YOUR IDENTITY".

4,119,247. BIZEQUITY, LLC, WILMINGTON, DE. SN 85-120,860. PUB. 8-30-2011, FILED 9-1-2010.

BIZ|EQUITY
What's Your Business Worth?

OWNER OF U.S. REG. NOS. 3,678,111, 3,715,066, AND OTHERS.

THE MARK CONSISTS OF THE LITERAL ELEMENTS "BIZEQUITY WHAT'S YOUR BUSINESS WORTH?" IN A STYLIZED FONT WITH A VERTICAL LINE BETWEEN "BIZ" AND "EQUITY".

CLASS 35—ADVERTISING AND BUSINESS

FOR PROVIDING ONLINE LISTINGS OF BUSINESSES FOR SALE (U.S. CLS. 100, 101 AND 102).
FIRST USE 10-0-2010; IN COMMERCE 10-0-2010.

CLASS 36—INSURANCE AND FINANCIAL

FOR BUSINESS VALUATION SERVICES; BUSINESS VALUATION SERVICES UTILIZING ONLINE BUSINESS VALUATION SOFTWARE; INFORMATION REGARDING BUSINESS VALUATION (U.S. CLS. 100, 101 AND 102).

FIRST USE 10-0-2010; IN COMMERCE 10-0-2010.

CLASS 42—SCIENTIFIC AND COMPUTER SERVICES

FOR PROVIDING ONLINE TEMPORARY USE OF NON-DOWNLOADABLE SOFTWARE USED IN PERFORMING BUSINESS VALUATIONS (U.S. CLS. 100 AND 101).

FIRST USE 10-0-2010; IN COMMERCE 10-0-2010.

4,119,248. TIRE MART, INC., ST. LOUIS, MO. SN 85-120,972. PUB. 11-23-2010, FILED 9-1-2010.

HONOR, GUTS & GLORY

THE MARK CONSISTS OF STANDARD CHARACTERS WITHOUT CLAIM TO ANY PARTICULAR FONT, STYLE, SIZE, OR COLOR.

OWNER OF U.S. REG. NOS. 3,815,492 AND 3,815,493.

CLASS 18—LEATHER GOODS

FOR REUSABLE SHOPPING BAGS NOT MADE OF PAPER OR PLASTIC (U.S. CLS. 1, 2, 3, 22 AND 41).
FIRST USE 6-0-2011; IN COMMERCE 6-0-2011.

CLASS 25—CLOTHING

FOR SHIRTS; SHORTS; PANTS; SWEATSHIRTS; SWEATPANTS; VISORS; CAPS; BANDANAS; HEADBANDS; BELTS; TANK TOPS; SWIM TRUNKS; BATHING SUITS; SWIM SUITS; DRESSES; SKIRTS; BLOUSES; TUBE TOPS; GLOVES; MEN'S AND WOMEN'S UNDERWEAR; BOXER SHORTS, WRIST BANDS (U.S. CLS. 22 AND 39).

FIRST USE 6-0-2011; IN COMMERCE 6-0-2011.

4,119,249. ALSCO INC., SALT LAKE CITY, UT. SN 85-121,031. PUB. 11-2-2010, FILED 9-1-2010.



OWNER OF U.S. REG. NOS. 2,602,954, 3,371,798, AND 3,595,815.

THE MARK CONSISTS OF THE WORD "HEALTHASSURE" ENCLOSED IN A PARTIAL ELLIPSE WITH THE WORDS BY "ALSCO" IN THE LOWER RIGHT OF THE MARK.

CLASS 35—ADVERTISING AND BUSINESS

FOR RETAIL STORE SERVICES AND ONLINE RETAIL STORE SERVICES FEATURING UNIFORMS, CLOTHES, HOSPITAL AND HEALTHCARE GARMENTS, LINENS, RUGS, FABRICS, GLOVES, FLOOR MATS, WIPERS, SHOE COVERS, CAPS AND MASKS, WET AND DRY MOPS, DUST CONTROL PRODUCTS, PAPER PRODUCTS, WASHROOM SUPPLIES, CHEMICALS AND SOAPS (U.S. CLS. 100, 101 AND 102).

FIRST USE 2-28-2011; IN COMMERCE 2-28-2011.

CLASS 37—CONSTRUCTION AND REPAIR

FOR PROVIDING LAUNDERING SERVICES FOR UNIFORMS, HOSPITAL AND HEALTHCARE GARMENTS, CLOTHES, LINENS, MATS, RUGS AND FABRICS TO HEALTHCARE PROVIDERS; RENTAL OF WET AND DRY MOPS; REPAIR OF UNIFORMS, HOSPITAL AND HEALTHCARE GARMENTS, CLOTHES, LINENS, RUGS AND FABRICS; RENTAL OF CLEANING EQUIPMENT, NAMELY, HYGIENE PRODUCTS FOR WASHROOMS AND RESTROOMS (U.S. CLS. 100, 103 AND 106).

FIRST USE 2-28-2011; IN COMMERCE 2-28-2011.

CLASS 45—PERSONAL AND LEGAL SERVICES

FOR RENTAL OF UNIFORMS, HOSPITAL AND HEALTHCARE GARMENTS, CLOTHING, HATS AND SMOCKS (U.S. CLS. 100 AND 101).

FIRST USE 2-28-2011; IN COMMERCE 2-28-2011.

4,119,260. APPLE INC., CUPERTINO, CA. SN 85-128,460.
PUB. 5-10-2011, FILED 9-13-2010.



PRIORITY CLAIMED UNDER SEC. 44(D) ON JAMAICA APPLICATION NO. 56,426, FILED 8-31-2010.
OWNER OF U.S. REG. NO. 2,935,038.

THE COLOR(S) BLUE, BLACK, AND WHITE IS/ARE CLAIMED AS A FEATURE OF THE MARK.

THE MARK CONSISTS OF TWO BLACK MUSICAL NOTES IN A CIRCLE APPEARING IN SHADES OF BLUE WITH A WHITE BORDER. THE COLOR GRAY APPEARING IN THE MARK MERELY REPRESENTS SHADOWING AND IS NOT PART OF THE MARK.

CLASS 35—ADVERTISING AND BUSINESS

FOR RETAIL STORE SERVICES IN THE FIELD OF ENTERTAINMENT, NAMELY, ELECTRONIC PUBLICATIONS, AUDIO, VIDEO, AND MULTIMEDIA CONTENT PROVIDED VIA THE INTERNET AND OTHER COMPUTER AND ELECTRONIC COMMUNICATION NETWORKS; ONLINE RETAIL STORE SERVICES IN THE FIELD OF ENTERTAINMENT FEATURING SUBSCRIPTIONS TO ELECTRONIC PUBLICATIONS, AUDIO, VIDEO, AND MULTIMEDIA CONTENT PROVIDED ONLINE AND VIA ELECTRONIC COMMUNICATIONS NETWORKS (U.S. CLS. 100, 101 AND 102).

FIRST USE 9-1-2010; IN COMMERCE 9-1-2010.

CLASS 38—COMMUNICATION

FOR TELECOMMUNICATIONS SERVICES, NAMELY, TRANSMISSION OF VOICE, DATA, GRAPHICS, IMAGES, AUDIO AND VIDEO BY MEANS OF TELECOMMUNICATIONS NETWORKS, WIRELESS COMMUNICATIONS NETWORKS, AND THE INTERNET; COMMUNICATION BY COMPUTER TERMINALS; PROVISION OF TELECOMMUNICATIONS CONNECTIONS TO COMPUTER DATABASES AND THE INTERNET; TRANSMISSION OF DATA AND OF INFORMATION VIA ELECTRONIC COMMUNICATIONS NETWORKS; PROVISION OF CONNECTIVITY SERVICES AND ACCESS TO ELECTRONIC COMMUNICATIONS NETWORKS, FOR TRANSMISSION OR RECEPTION OF TEXT, AUDIO, VIDEO, AND MULTIMEDIA CONTENT; ELECTRONIC TRANSMISSION OF STREAMED AND DOWNLOADABLE TEXT, AUDIO, VIDEO, AND MULTIMEDIA CONTENT VIA COMPUTER AND OTHER COMMUNICATIONS NETWORKS; PROVIDING ON-LINE CHAT ROOMS, BULLETIN BOARDS AND COMMUNITY FORUMS FOR THE TRANSMISSION OF MESSAGES AMONG COMPUTER USERS IN THE FIELD OF GENERAL INTEREST; WEB CASTING SERVICES; BROADCASTING OR TRANSMISSION OF RADIO AND TELEVISION PROGRAMS; STREAMING OF AUDIO AND VIDEO CONTENT VIA THE INTERNET (U.S. CLS. 100, 101 AND 104).

FIRST USE 9-1-2010; IN COMMERCE 9-1-2010.

CLASS 41—EDUCATION AND ENTERTAINMENT

FOR ENTERTAINMENT SERVICES, NAMELY, PROVIDING ONLINE INFORMATION AND DATABASES FEATURING MUSIC, FILMS, MUSIC VIDEOS, TELEVISION PROGRAMS, MOTION PICTURES, CURRENT EVENT AND ENTERTAINMENT NEWS IN THE FIELD OF ENTERTAINMENT, SPORTS, GAMES, CULTURAL EVENTS, AND ENTERTAINMENT-RELATED PROGRAMS; PROVIDING PRERECORDED NON-DOWNLOADABLE AUDIO AND AUDIOVISUAL CONTENT, TEXT, INFORMATION AND COMMENTARY IN THE NATURE OF CLASSES, LECTURES, PODCASTS AND ELECTRONIC PUBLICATIONS, IN THE NATURE OF BOOKS, MAGAZINES, AND NEWSPAPERS, IN THE FIELDS OF K-12 EDUCATION AND UNIVERSITY-LEVEL SUBJECTS AND TOPICS OF GENERAL INTEREST, NAMELY, ENTERTAINMENT, MUSIC, CONCERTS, FILMS, VIDEOS, MOTION PICTURES, RADIO, TELEVISION, NEWS, SPORTS, GAMES AND CULTURAL EVENTS; PUBLISHING OF ELECTRONIC PUBLICATIONS; PROVIDING ONLINE PUBLICATIONS AND NON-DOWNLOADABLE ELECTRONIC PUBLICATIONS IN THE NATURE OF BOOKS, MAGAZINES AND NEWSPAPERS IN THE FIELD OF ENTERTAINMENT, SPORTS, GAMES, CULTURAL EVENTS, AND ENTERTAINMENT-RELATED PROGRAMS (U.S. CLS. 100, 101 AND 107).

FIRST USE 9-1-2010; IN COMMERCE 9-1-2010.

CLASS 42—SCIENTIFIC AND COMPUTER SERVICES

FOR PROVIDING SEARCH ENGINES FOR OBTAINING DATA VIA COMMUNICATIONS NETWORKS; PROVIDING TEMPORARY USE OF ON-LINE NON-DOWNLOADABLE SOFTWARE TO ENABLE USERS TO PROGRAM TEXT, AUDIO, VIDEO, AND MULTIMEDIA CONTENT; INTERNET SERVICES, NAMELY, CREATING INDEXES OF INFORMATION, SITES AND OTHER RESOURCES AVAILABLE ON GLOBAL COMPUTER NETWORKS FOR OTHERS; SEARCHING, BROWSING AND RETRIEVING INFORMATION, SITES, AND OTHER RESOURCES AVAILABLE ON GLOBAL COMPUTER NETWORKS AND OTHER COMMUNICATION NETWORKS FOR OTHERS; PROVIDING ON-LINE FACILITIES, VIA A GLOBAL COMPUTER NETWORK, TO ENABLE USERS TO PROGRAM TEXT, AUDIO, VIDEO, AND MULTIMEDIA CONTENT (U.S. CLS. 100 AND 101).

FIRST USE 9-1-2010; IN COMMERCE 9-1-2010.

CLASS 45—PERSONAL AND LEGAL SERVICES

FOR ONLINE SOCIAL NETWORKING SERVICES; PROVIDING A SOCIAL NETWORKING WEBSITE FOR ENTERTAINMENT PURPOSES (U.S. CLS. 100 AND 101).

FIRST USE 9-1-2010; IN COMMERCE 9-1-2010.

4,119,262. IHOSPITAL, LLC, TAMPA, FL. SN 85-130,386. PUB. 5-3-2011, FILED 9-15-2010.

IHOSPITAL

THE MARK CONSISTS OF STANDARD CHARACTERS WITHOUT CLAIM TO ANY PARTICULAR FONT, STYLE, SIZE, OR COLOR.

CLASS 35—ADVERTISING AND BUSINESS

FOR RETAIL AND ON-LINE STORE SERVICES FEATURING ACCESSORIES FOR PORTABLE AND HANDHELD DIGITAL ELECTRONIC DEVICES, CELL PHONES, PERSONAL DIGITAL ASSISTANTS, LAPTOPS, SET-TOP BOXES, AND PORTABLE MUSIC PLAYERS (U.S. CLS. 100, 101 AND 102).

FIRST USE 4-1-2010; IN COMMERCE 4-1-2010.

CLASS 36—INSURANCE AND FINANCIAL

FOR PROVIDING EXTENDED WARRANTIES ON PORTABLE AND HANDHELD DIGITAL ELECTRONIC DEVICES, CELL PHONES, PERSONAL DIGITAL ASSISTANTS, LAPTOPS, SET-TOP BOXES, AND PORTABLE MUSIC PLAYERS (U.S. CLS. 100, 101 AND 102).

FIRST USE 4-1-2010; IN COMMERCE 4-1-2010.

CLASS 37—CONSTRUCTION AND REPAIR

FOR INSTALLATION, MAINTENANCE AND REPAIR OF HARDWARE RELATED TO CELL PHONES, COMPUTERS AND COMPUTER PERIPHERALS, PORTABLE AND HANDHELD DIGITAL ELECTRONIC DEVICES, CELL PHONES, PERSONAL DIGITAL ASSISTANTS, LAPTOPS, SET-TOP BOXES, AND PORTABLE MUSIC PLAYERS (U.S. CLS. 100, 103 AND 106).

FIRST USE 4-1-2010; IN COMMERCE 4-1-2010.

CLASS 42—SCIENTIFIC AND COMPUTER SERVICES

FOR INSTALLATION, MAINTENANCE AND REPAIR OF SOFTWARE RELATED TO CELL PHONES, COMPUTERS AND COMPUTER PERIPHERALS, PORTABLE AND HANDHELD DIGITAL ELECTRONIC DEVICES, CELL PHONES, PERSONAL DIGITAL ASSISTANTS, LAPTOPS, SET-TOP BOXES, AND PORTABLE MUSIC PLAYERS (U.S. CLS. 100 AND 101).

FIRST USE 4-1-2010; IN COMMERCE 4-1-2010.

4,119,266. CRU-VAR CORPORATION, LAUREL, MD. SN 85-133,110. PUB. 5-31-2011, FILED 9-20-2010.



NO CLAIM IS MADE TO THE EXCLUSIVE RIGHT TO USE "CORPORATION", APART FROM THE MARK AS SHOWN.

THE COLOR(S) RED, LIGHT BLUE AND BLACK IS/ARE CLAIMED AS A FEATURE OF THE MARK.

THE MARK CONSISTS OF A RED HALF MOON SHAPE AS AN ENHANCED LETTER "C" WITH THE WORDS "CRU-VAR" IN LIGHT BLUE COLOR AND THE WORD "CORPORATION" IN BLACK COLOR WRITTEN BESIDES IT AS SHOWN IN THE MARK.

CLASS 39—TRANSPORTATION AND STORAGE

FOR TRAVEL AGENCY SERVICES, NAMELY, MAKING RESERVATIONS AND BOOKING FOR AIRLINE TRANSPORTATION, TRAVEL BOOKING AGENCY AND RESERVATION SERVICES OF SEATS FOR TRAVEL (U.S. CLS. 100 AND 105).

FIRST USE 8-1-2011; IN COMMERCE 8-1-2011.

CLASS 43—HOTEL AND RESTAURANT SERVICES

FOR TRAVEL AGENCY SERVICES, NAMELY, BOOKING TEMPORARY LODGING AND BOOKING HOTELS (U.S. CLS. 100 AND 101).

FIRST USE 8-1-2011; IN COMMERCE 8-1-2011.

4,119,271. FEDERATED MUTUAL INSURANCE COMPANY, OWATONNA, MN. SN 85-138,867. PUB. 12-7-2010, FILED 9-27-2010.

CONTRACTOR SHIELD

THE MARK CONSISTS OF STANDARD CHARACTERS WITHOUT CLAIM TO ANY PARTICULAR FONT, STYLE, SIZE, OR COLOR.

OWNER OF U.S. REG. NOS. 1,326,307, 1,653,345, AND 3,229,119.

NO CLAIM IS MADE TO THE EXCLUSIVE RIGHT TO USE "CONTRACTOR", APART FROM THE MARK AS SHOWN.

CLASS 35—ADVERTISING AND BUSINESS

FOR BUSINESS RISK MANAGEMENT (U.S. CLS. 100, 101 AND 102).

FIRST USE 5-11-2010; IN COMMERCE 5-11-2010.

CLASS 36—INSURANCE AND FINANCIAL

FOR FINANCIAL RISK MANAGEMENT (U.S. CLS. 100, 101 AND 102).

FIRST USE 5-11-2010; IN COMMERCE 5-11-2010.

4,119,273. COMBEX, INC., DBA CHANEY INSTRUMENT COMPANY, LAKE GENEVA, WI. SN 85-139,589. PUB. 5-24-2011, FILED 9-28-2010.

**IT'S MORE THAN ACCURATE,
IT'S ACU-RITE**

THE MARK CONSISTS OF STANDARD CHARACTERS WITHOUT CLAIM TO ANY PARTICULAR FONT, STYLE, SIZE, OR COLOR.

OWNER OF U.S. REG. NOS. 686,877 AND 2,216,255.

CLASS 9—ELECTRICAL AND SCIENTIFIC APPARATUS

FOR WEATHER STATIONS FOR HOUSEHOLD USE, NAMELY, ELECTRONIC WEATHER STATIONS COMPRISED OF ELECTRONIC SENSORS AND CIRCUITRY FOR MEASURING TEMPERATURE, HUMIDITY, BAROMETRIC PRESSURE OR OTHER WEATHER PARAMETERS, ALL SOLD AS A UNIT (U.S. CLS. 21, 23, 26, 36 AND 38).

FIRST USE 2-24-2011; IN COMMERCE 2-24-2011.

CLASS 14—JEWELRY

FOR CLOCKS (U.S. CLS. 2, 27, 28 AND 50).
FIRST USE 2-24-2011; IN COMMERCE 2-24-2011.

4,119,275. CHECKS IN THE MAIL, INC., NEW BRAUNFELS,
TX. SN 85-140,200. PUB. 5-10-2011, FILED 9-28-2010.



OWNER OF U.S. REG. NOS. 3,342,914 AND 3,347,064.
THE MARK CONSISTS OF THE STYLIZED WORDS,
"EXPRESSIONERY.COM EXPRESS YOUR STYLE IN
PRINT", ALONG WITH VARIOUS HEART, STAR AND
SWIRL DESIGNS AND A STYLIZED REPRESENTATION
OF AN ENVELOPE AND CARD.

CLASS 16—PAPER GOODS AND PRINTED MATTER

FOR ADDRESS LABELS; ADDRESS STAMPS; AN-
NOUNCEMENT CARDS; BLANK JOURNALS; BOOK
MARKS; BOOK PLATES; BUSINESS CARDS; CALEN-
DARS; CHECKBOOK COVERS; COASTERS OF PAPER;
GIFT CARDS; GREETING CARDS; INK STAMPS;
MEMO PADS; NOTE CARDS; NOTE PAPER; PAPER
EMBOSSERS; PAPER GIFT TAGS; PAPER LABELS;
PAPER NAPKINS; PAPER PICTURE MOUNTS; PIC-
TURE CARDS; PRINTED INVITATIONS; PRINTED RECI-
PE CARDS; STATIONERY (U.S. CLS. 2, 5, 22, 23, 29, 37,
38 AND 50).

FIRST USE 9-30-2007; IN COMMERCE 9-30-2007.

CLASS 18—LEATHER GOODS

FOR CARD WALLETS; LUGGAGE TAGS (U.S. CLS. 1,
2, 3, 22 AND 41).

FIRST USE 12-31-2008; IN COMMERCE 12-31-2008.

CLASS 21—HOUSEWARES AND GLASS

FOR DECORATIVE PLATES; TRAYS (U.S. CLS. 2, 13,
23, 29, 30, 33, 40 AND 50).

FIRST USE 12-31-2008; IN COMMERCE 12-31-2008.

4,119,276. CHECKS IN THE MAIL, INC., NEW BRAUNFELS,
TX. SN 85-140,219. PUB. 5-10-2011, FILED 9-28-2010.

EXPRESS YOUR STYLE IN PRINT

THE MARK CONSISTS OF STANDARD CHARACTERS
WITHOUT CLAIM TO ANY PARTICULAR FONT, STYLE,
SIZE, OR COLOR.

CLASS 16—PAPER GOODS AND PRINTED MATTER

FOR ADDRESS LABELS; ADDRESS STAMPS; AN-
NOUNCEMENT CARDS; BLANK JOURNALS; BOOK
PLATES; BOOKMARKS; BUSINESS CARDS; CALEN-
DARS; CHECKBOOK COVERS; COASTERS MADE OF
PAPER; GIFT CARDS; GREETING CARDS; INK
STAMPS; MEMO PADS; NOTE CARDS; NOTE PAPER;
PAPER EMBOSSERS; PAPER GIFT TAGS; PAPER LA-
BELS; PAPER NAPKINS; PAPER PICTURE MOUNTS;
PICTURE CARDS; PRINTED INVITATIONS; PRINTED
RECIPE CARDS; STATIONERY (U.S. CLS. 2, 5, 22, 23, 29,
37, 38 AND 50).

FIRST USE 9-30-2007; IN COMMERCE 9-30-2007.

CLASS 18—LEATHER GOODS

FOR CARD WALLETS; LUGGAGE TAGS (U.S. CLS. 1,
2, 3, 22 AND 41).

FIRST USE 12-31-2008; IN COMMERCE 12-31-2008.

CLASS 21—HOUSEWARES AND GLASS

FOR DECORATIVE PLATES; TRAYS (U.S. CLS. 2, 13,
23, 29, 30, 33, 40 AND 50).

FIRST USE 12-31-2008; IN COMMERCE 12-31-2008.

4,119,277. CHECKS IN THE MAIL, INC., NEW BRAUNFELS,
TX. SN 85-140,240. PUB. 5-10-2011, FILED 9-28-2010.

EXPRESSIONERY.COM

THE MARK CONSISTS OF STANDARD CHARACTERS
WITHOUT CLAIM TO ANY PARTICULAR FONT, STYLE,
SIZE, OR COLOR.

OWNER OF U.S. REG. NOS. 3,342,914 AND 3,347,064.

CLASS 16—PAPER GOODS AND PRINTED MATTER

FOR ADDRESS LABELS; ADDRESS STAMPS; AN-
NOUNCEMENT CARDS; BLANK JOURNALS; BOOK
PLATES; BOOKMARKS; BUSINESS CARDS; CALEN-
DARS; CHECKBOOK COVERS; COASTERS MADE OF
PAPER; GIFT CARDS; GREETING CARDS; INK
STAMPS; MEMO PADS; NOTE CARDS; PAPER EMBOSS-
ERS; PAPER GIFT TAGS; PAPER LABELS; PAPER
NAPKINS; PAPER PICTURE MOUNTS; PICTURE
CARDS; PRINTED INVITATIONS; PRINTED RECIPE
CARDS; STATIONERY (U.S. CLS. 2, 5, 22, 23, 29, 37, 38
AND 50).

FIRST USE 9-30-2007; IN COMMERCE 9-30-2007.

CLASS 18—LEATHER GOODS

FOR CARD WALLETS; LUGGAGE TAGS (U.S. CLS. 1,
2, 3, 22 AND 41).

FIRST USE 12-31-2008; IN COMMERCE 12-31-2008.

CLASS 21—HOUSEWARES AND GLASS

FOR DECORATIVE PLATES; TRAYS (U.S. CLS. 2, 13,
23, 29, 30, 33, 40 AND 50).

FIRST USE 12-31-2008; IN COMMERCE 12-31-2008.

4,119,279. LACKEY BALLARD PRODUCTIONS, LLC, DURHAM, NC. SN 85-140,854. PUB. 4-19-2011, FILED 9-29-2010.

4,119,283. SEARS BRANDS, LLC, HOFFMAN ESTATES, IL. SN 85-144,971. PUB. 7-12-2011, FILED 10-5-2010.

TAMARA LACKEY

PORTRAITS OF HEROES AT HOME

THE MARK CONSISTS OF STANDARD CHARACTERS WITHOUT CLAIM TO ANY PARTICULAR FONT, STYLE, SIZE, OR COLOR.

THE NAME(S), PORTRAIT(S), AND/OR SIGNATURE(S) SHOWN IN THE MARK IDENTIFIES A LIVING INDIVIDUAL, WHOSE CONSENT(S) TO REGISTER IS MADE OF RECORD.

CLASS 9—ELECTRICAL AND SCIENTIFIC APPARATUS

FOR DIGITAL MEDIA, NAMELY, PRE-RECORDED DVDS FEATURING INFORMATION, INSTRUCTION, AND TIPS IN THE FIELD OF PHOTOGRAPHY; AN EDUCATIONAL KIT COMPRISING DVDS FEATURING INFORMATION, INSTRUCTION, AND TIPS IN THE FIELD OF PHOTOGRAPHY, ALONG WITH PHOTOGRAPHY GUIDE BOOK AND QUICK REFERENCE GUIDE, SOLD AS A UNIT (U.S. CLS. 21, 23, 26, 36 AND 38).

FIRST USE 1-6-2011; IN COMMERCE 1-6-2011.

CLASS 16—PAPER GOODS AND PRINTED MATTER

FOR EDUCATIONAL PUBLICATIONS, NAMELY, BOOKS AND GUIDES FEATURING INFORMATION, INSTRUCTION, AND TIPS IN THE FIELD OF PHOTOGRAPHY (U.S. CLS. 2, 5, 22, 23, 29, 37, 38 AND 50).

FIRST USE 1-6-2011; IN COMMERCE 1-6-2011.

4,119,280. UNITEX INTERNATIONAL, INC., SUWANEE, GA. SN 85-142,206. PUB. 10-11-2011, FILED 9-30-2010.

GREEN LIFESTYLE

THE MARK CONSISTS OF STANDARD CHARACTERS WITHOUT CLAIM TO ANY PARTICULAR FONT, STYLE, SIZE, OR COLOR.

NO CLAIM IS MADE TO THE EXCLUSIVE RIGHT TO USE "GREEN", APART FROM THE MARK AS SHOWN.

CLASS 22—CORDAGE AND FIBERS

FOR DROP CLOTHS (U.S. CLS. 1, 2, 7, 19, 22, 42 AND 50).

FIRST USE 2-10-2010; IN COMMERCE 2-10-2010.

CLASS 24—FABRICS

FOR BATH TOWELS; KITCHEN TOWELS; DISH CLOTHS; WASH CLOTHS (U.S. CLS. 42 AND 50).

FIRST USE 1-0-2009; IN COMMERCE 1-0-2009.

THE MARK CONSISTS OF STANDARD CHARACTERS WITHOUT CLAIM TO ANY PARTICULAR FONT, STYLE, SIZE, OR COLOR.

OWNER OF U.S. REG. NO. 3,481,593.

NO CLAIM IS MADE TO THE EXCLUSIVE RIGHT TO USE "PORTRAITS", APART FROM THE MARK AS SHOWN.

CLASS 35—ADVERTISING AND BUSINESS

FOR PROMOTING PUBLIC AWARENESS AND APPRECIATION OF THE HEROISM AND EXPERIENCES OF U.S. MILITARY PERSONNEL AND MILITARY VETERANS (U.S. CLS. 100, 101 AND 102).

FIRST USE 12-0-2010; IN COMMERCE 12-0-2010.

CLASS 41—EDUCATION AND ENTERTAINMENT

FOR ENTERTAINMENT SERVICES, NAMELY, PROVIDING ON-GOING TELEVISION PROGRAMS IN THE FIELD OF PROFILES OF U.S. MILITARY PERSONNEL, MILITARY VETERANS AND THEIR FAMILIES VIA A GLOBAL COMPUTER NETWORK; ENTERTAINMENT SERVICES, NAMELY, PROVIDING A WEB SITE FEATURING PHOTOGRAPHIC, VIDEO AND PROSE PRESENTATIONS FEATURING PROFILES OF U.S. MILITARY PERSONNEL, MILITARY VETERANS AND THEIR FAMILIES (U.S. CLS. 100, 101 AND 107).

FIRST USE 12-0-2010; IN COMMERCE 12-0-2010.

4,119,291. DEMERELL, ANNALEE RENEE PICKNELL, CHARLESTON, SC. SN 85-151,395. PUB. 6-14-2011, FILED 10-13-2010.

WearYouAre

THE MARK CONSISTS OF STANDARD CHARACTERS WITHOUT CLAIM TO ANY PARTICULAR FONT, STYLE, SIZE, OR COLOR.

CLASS 18—LEATHER GOODS

FOR ALL-PURPOSE CARRYING BAGS; AMENITY BAGS SOLD EMPTY; PURSES; TOTE BAGS (U.S. CLS. 1, 2, 3, 22 AND 41).

FIRST USE 7-1-2008; IN COMMERCE 7-1-2008.

CLASS 25—CLOTHING

FOR BOTTOMS; BRIDESMAID DRESSES; CUSTOM MADE TO MEASURE SUITS FOR MEN AND WOMEN; DRESS PANTS; DRESS SUITS; DRESSES; EVENING DRESSES; MEN'S AND WOMEN'S JACKETS, COATS, TROUSERS, VESTS; PANTS; SHIRTS; SHIRTS AND SHORT-SLEEVED SHIRTS; SKIRTS AND DRESSES; SLACKS; TOPS; WEARABLE GARMENTS AND CLOTHING, NAMELY, SHIRTS; WEDDING DRESSES; WEDDING GOWNS; WOMEN'S CEREMONIAL DRESSES; BELTS FOR CLOTHING; CLOTHING, NAMELY, BASE LAYERS; DRESSING GOWNS AND BATH ROBES; HEAD WEAR; SHOES; SLIPPERS; T-SHIRTS; TANK TOPS; TIES; WRAPS (U.S. CLS. 22 AND 39).

FIRST USE 7-1-2008; IN COMMERCE 7-1-2008.

4,119,294. MAURICES INCORPORATED, DULUTH, MN. SN 85-153,919. PUB. 4-5-2011, FILED 10-15-2010.

MAIN STREET MODEL SEARCH

THE MARK CONSISTS OF STANDARD CHARACTERS WITHOUT CLAIM TO ANY PARTICULAR FONT, STYLE, SIZE, OR COLOR.

NO CLAIM IS MADE TO THE EXCLUSIVE RIGHT TO USE "MODEL SEARCH", APART FROM THE MARK AS SHOWN.

CLASS 35—ADVERTISING AND BUSINESS

FOR ARRANGING AND CONDUCTING A MODEL SEARCH CONTEST TO PROMOTE THE SALE OF CLOTHING AND ACCESSORIES (U.S. CLS. 100, 101 AND 102).

FIRST USE 3-0-2011; IN COMMERCE 3-0-2011.

CLASS 41—EDUCATION AND ENTERTAINMENT

FOR ENTERTAINMENT SERVICES, NAMELY, A MODEL SEARCH CONTEST (U.S. CLS. 100, 101 AND 107).

FIRST USE 3-0-2011; IN COMMERCE 3-0-2011.

4,119,295. GINGERCUBE, INC., FLOWER MOUND, TX. SN 85-154,171. PUB. 7-12-2011, FILED 10-15-2010.

GINGERCUBE

THE MARK CONSISTS OF STANDARD CHARACTERS WITHOUT CLAIM TO ANY PARTICULAR FONT, STYLE, SIZE, OR COLOR.

CLASS 9—ELECTRICAL AND SCIENTIFIC APPARATUS

FOR COMPUTER SOFTWARE, NAMELY, SOFTWARE FOR PHYSICIAN BILLING, DISPLAYING PATIENT MEDICAL RECORDS, MANAGING COMPLIANCE WITH REGULATIONS, AND PROVIDING MEDICAL RECORDS (U.S. CLS. 21, 23, 26, 36 AND 38).

FIRST USE 12-31-2010; IN COMMERCE 12-31-2010.

CLASS 42—SCIENTIFIC AND COMPUTER SERVICES

FOR PROVIDING ON-LINE, NON-DOWNLOADABLE, INTERNET-BASED SOFTWARE APPLICATIONS FOR PHYSICIANS AND HEALTH CARE INSTITUTIONS; APPLICATION SERVICE PROVIDER (ASP) FEATURING SOFTWARE FOR USE IN PHYSICIAN BILLING, DISPLAYING PATIENT MEDICAL RECORDS, MANAGING COMPLIANCE WITH REGULATIONS, AND PROVIDING MEDICAL RECORDS; PROVIDING A WEB SITE FEATURING TECHNOLOGY THAT ENABLES USERS TO OPTIMIZE DAILY OPERATIONAL PROCESSES OF MEDICAL PRACTICES, NAMELY, PHYSICIAN BILLING, DISPLAYING PATIENT MEDICAL RECORDS, MANAGING COMPLIANCE WITH REGULATIONS, AND PROVIDING MEDICAL RECORDS; APPLICATION SERVICE PROVIDER (ASP) FEATURING SOFTWARE FOR USE BY HEALTH CARE PROVIDERS FOR PHYSICIAN BILLING, DISPLAYING PATIENT MEDICAL RECORDS, MANAGING COMPLIANCE WITH REGULATIONS, AND PROVIDING MEDICAL RECORDS (U.S. CLS. 100 AND 101).

FIRST USE 12-31-2010; IN COMMERCE 12-31-2010.

4,119,296. GINGERCUBE, INC., FLOWER MOUND, TX. SN 85-154,198. PUB. 7-12-2011, FILED 10-15-2010.



THE MARK CONSISTS OF A GRAPHIC IMAGE REPRESENTING A STETHOSCOPE CONNECTED TO A MOBILE DEVICE.

CLASS 9—ELECTRICAL AND SCIENTIFIC APPARATUS

FOR COMPUTER SOFTWARE, NAMELY, SOFTWARE FOR PHYSICIAN BILLING, DISPLAYING PATIENT MEDICAL RECORDS, MANAGING COMPLIANCE WITH REGULATIONS, AND PROVIDING MEDICAL RECORDS (U.S. CLS. 21, 23, 26, 36 AND 38).

FIRST USE 12-31-2010; IN COMMERCE 12-31-2010.

CLASS 42—SCIENTIFIC AND COMPUTER SERVICES

FOR PROVIDING ON-LINE, NON-DOWNLOADABLE, INTERNET-BASED SOFTWARE APPLICATIONS FOR PHYSICIANS AND HEALTH CARE INSTITUTIONS; APPLICATION SERVICE PROVIDER (ASP) FEATURING SOFTWARE FOR USE IN PHYSICIAN BILLING, DISPLAYING PATIENT MEDICAL RECORDS, MANAGING COMPLIANCE WITH REGULATIONS, AND PROVIDING MEDICAL RECORDS; PROVIDING A WEB SITE FEATURING TECHNOLOGY THAT ENABLES USERS TO OPTIMIZE DAILY OPERATIONAL PROCESSES OF MEDICAL PRACTICES, NAMELY, PHYSICIAN BILLING, DISPLAYING PATIENT MEDICAL RECORDS, MANAGING COMPLIANCE WITH REGULATIONS, AND PROVIDING MEDICAL RECORDS; APPLICATION SERVICE PROVIDER (ASP) FEATURING SOFTWARE FOR USE BY HEALTH CARE PROVIDERS FOR PHYSICIAN BILLING, DISPLAYING PATIENT MEDICAL RECORDS, MANAGING COMPLIANCE WITH REGULATIONS, AND PROVIDING MEDICAL RECORDS (U.S. CLS. 100 AND 101).

FIRST USE 12-31-2010; IN COMMERCE 12-31-2010.

4,119,307. FOODILY, INC., SAN MATEO, CA. SN 85-160,870. PUB. 4-26-2011, FILED 10-26-2010.

FOODILY

THE MARK CONSISTS OF STANDARD CHARACTERS WITHOUT CLAIM TO ANY PARTICULAR FONT, STYLE, SIZE, OR COLOR.

4,119,302. EASTERN SHORE NURSERY OF VIRGINIA, LLC, KELLER, VA. SN 85-158,133. PUB. 11-8-2011, FILED 10-21-2010.



NO CLAIM IS MADE TO THE EXCLUSIVE RIGHT TO USE "PLANTS", APART FROM THE MARK AS SHOWN.

THE MARK CONSISTS OF A DRAWING OF A DROP OF WATER FALLING ONTO A PLANT LEAF WITH THE WORD "GREENER" WRITTEN TO THE LEFT SIDE OF THE DRAWING AND THE WORD "PLANTS" WRITTEN TO THE RIGHT SIDE OF THE DRAWING.

CLASS 31—NATURAL AGRICULTURAL PRODUCTS

FOR LIVE SHRUBS, LIVE TREES, LIVE PLANTS, LIVING FRUIT PLANTS (U.S. CLS. 1 AND 46).
FIRST USE 2-0-2011; IN COMMERCE 2-0-2011.

CLASS 44—MEDICAL, BEAUTY AND AGRICULTURAL SERVICES

FOR PROVIDING A WEBSITE FEATURING INFORMATION ABOUT GREEN HOME-GARDENING PRACTICES, PROVIDING A WEBSITE FEATURING INFORMATION ABOUT HOME-GARDENING PRACTICES THAT DO NOT CONTRIBUTE TO THE POLLUTION OF ADJACENT BAYS, CANALS, ESTUARIES, LAKES, PONDS, RIVERS, STREAMS, OR WATERWAYS (U.S. CLS. 100 AND 101).

FIRST USE 2-0-2011; IN COMMERCE 2-0-2011.

CLASS 35—ADVERTISING AND BUSINESS

FOR ADVERTISING AND MARKETING; PROMOTIONAL SERVICES, NAMELY, PROMOTING THE GOODS OF OTHERS BY MEANS OF PROVIDING ON-LINE COUPONS; PROVIDING A WEBSITE WHERE USERS CAN POST RATINGS, COMMENTS, REVIEWS AND RECOMMENDATIONS ON RECIPES, FOOD, BEVERAGES, COCKTAIL RECIPES AND WINE; PROVIDING ADVERTISING SERVICE TO DISTRIBUTE ADVERTISEMENTS FOR DISPLAY ON INTERNET, NAMELY, IN WEBSITES, SOCIAL CONVERSATIONS OVER THE INTERNET, E-MAILS, MICROBLOGS, BLOGS, ELECTRONIC MESSAGES, INSTANT MESSAGES, TEXT MESSAGES, MULTIMEDIA MESSAGES, SOCIAL NETWORKS, STATUS UPDATES, FORUMS, AND ELECTRONIC BULLETIN BOARDS (U.S. CLS. 100, 101 AND 102).

FIRST USE 12-15-2010; IN COMMERCE 12-15-2010.

CLASS 41—EDUCATION AND ENTERTAINMENT

FOR ON-LINE JOURNALS, NAMELY, BLOGS IN THE FIELD OF RECIPES, COOKING, FOOD, BEVERAGES, COCKTAILS AND WINE (U.S. CLS. 100, 101 AND 107).
FIRST USE 12-15-2010; IN COMMERCE 12-15-2010.

CLASS 42—SCIENTIFIC AND COMPUTER SERVICES

FOR PROVISION OF INTERNET SEARCH ENGINES; PROVIDING INTERNET SEARCH ENGINES FOR FINDING RECIPES; PROVIDING A WEBSITE FEATURING TECHNOLOGY THAT ENABLES USERS TO CREATE, ORGANIZE, STORE, MANAGE AND SHARE A VIRTUAL RECIPE COLLECTION BY SAVING SEARCHES; HOSTING AN ON-LINE COMMUNITY WEBSITE FEATURING DISCUSSIONS ABOUT RECIPES, COOKING, FOOD, BEVERAGES, COCKTAILS AND WINE (U.S. CLS. 100 AND 101).

FIRST USE 12-15-2010; IN COMMERCE 12-15-2010.

CLASS 43—HOTEL AND RESTAURANT SERVICES

FOR PROVIDING A WEBSITE FEATURING INFORMATION IN THE FIELD OF RECIPES, COOKING, FOOD, BEVERAGES, COCKTAILS AND WINE (U.S. CLS. 100 AND 101).

FIRST USE 12-15-2010; IN COMMERCE 12-15-2010.

4,119,309. RUG DOCTOR, INC., PLANO, TX. SN 85-161,410.
PUB. 4-26-2011, FILED 10-26-2010.

Mighty Pro X3

THE MARK CONSISTS OF STANDARD CHARACTERS WITHOUT CLAIM TO ANY PARTICULAR FONT, STYLE, SIZE, OR COLOR.

OWNER OF U.S. REG. NOS. 2,475,799 AND 2,747,284.

NO CLAIM IS MADE TO THE EXCLUSIVE RIGHT TO USE "PRO", APART FROM THE MARK AS SHOWN.

CLASS 7—MACHINERY

FOR ELECTRICALLY OPERATED MACHINES FOR POLISHING AND EXTRACTING DIRT AND FOREIGN MATTER FROM WALLS, CEILINGS, FLOORS, RUGS, CARPETS, UPHOLSTERY, FURNITURE AND OTHER TEXTILES OR FIBROUS FABRICS OR MATERIALS; FLOOR POLISHING MACHINES (U.S. CLS. 13, 19, 21, 23, 31, 34 AND 35).

FIRST USE 1-13-2011; IN COMMERCE 1-13-2011.

CLASS 37—CONSTRUCTION AND REPAIR

FOR RENTAL OF CARPET CLEANING MACHINES, NAMELY, CLEANING AND REMOVING FOREIGN MATTER FROM RUGS, CARPETING AND UPHOLSTERED FURNITURE, AND OTHER FIBROUS MATERIAL FOR OTHERS (U.S. CLS. 100, 103 AND 106).

FIRST USE 1-13-2001; IN COMMERCE 1-13-2011.

4,119,338. CAREERBUILDER, LLC, CHICAGO, IL. SN 85-183,166. PUB. 8-16-2011, FILED 11-23-2010.

MONK-E-MAIL

THE MARK CONSISTS OF STANDARD CHARACTERS WITHOUT CLAIM TO ANY PARTICULAR FONT, STYLE, SIZE, OR COLOR.

CLASS 35—ADVERTISING AND BUSINESS

FOR PROVIDING ON-LINE PERSONNEL RECRUITMENT, PERSONNEL MANAGEMENT INFORMATION AND JOB SEARCH INFORMATION SERVICES; PROVIDING AN ON-LINE INTERACTIVE COMPUTER DATABASE IN THE FIELD OF RECRUITMENT AND EMPLOYMENT INFORMATION; EMPLOYMENT ADVERTISING; PROVIDING CAREER INFORMATION AND ON-LINE EMPLOYMENT INFORMATION IN THE FIELD OF JOB RESOURCES (U.S. CLS. 100, 101 AND 102).

FIRST USE 1-28-2011; IN COMMERCE 1-28-2011.

CLASS 38—COMMUNICATION

FOR ELECTRONIC MESSAGE TRANSMISSION; ELECTRONIC MESSAGING SERVICES IN THE NATURE OF ON-LINE GENERATION OF ELECTRONIC MESSAGES; ON-LINE SERVICES, NAMELY, MESSAGE SENDING; ELECTRONIC DATA TRANSMISSION, NAMELY, MESSAGE TRANSMITTAL VIA A GLOBAL COMPUTER NETWORK (U.S. CLS. 100, 101 AND 104).

FIRST USE 1-18-2006; IN COMMERCE 1-18-2006.

4,119,350. PETHEALTH SERVICES INC., OAKVILLE, CANADA. SN 85-187,584. PUB. 11-1-2011, FILED 11-30-2010.

Petango PetMatch

THE MARK CONSISTS OF STANDARD CHARACTERS WITHOUT CLAIM TO ANY PARTICULAR FONT, STYLE, SIZE, OR COLOR.

NO CLAIM IS MADE TO THE EXCLUSIVE RIGHT TO USE "PETMATCH", APART FROM THE MARK AS SHOWN.

CLASS 35—ADVERTISING AND BUSINESS

FOR CONDUCTING ON-LINE CONSUMER SURVEYS REGARDING PET ADOPTION AND PET TO HUMAN MATCHING (U.S. CLS. 100, 101 AND 102).

FIRST USE 5-3-2011; IN COMMERCE 5-3-2011.

CLASS 45—PERSONAL AND LEGAL SERVICES

FOR PROVIDING AN ON-LINE MATCHING SERVICE IN WHICH REGISTERED USERS ARE PROVIDED A LIST OF PETS AVAILABLE FOR ADOPTION THAT FIT THE USER'S REQUIREMENTS, WANTS AND NEEDS (U.S. CLS. 100 AND 101).

FIRST USE 5-3-2011; IN COMMERCE 5-3-2011.

4,119,355. INTERNATIONAL SPECIALTIES CO., LTD., JORDAN, HONG KONG. SN 85-188,852. PUB. 4-19-2011, FILED 12-2-2010.

DIVOTI

THE MARK CONSISTS OF STANDARD CHARACTERS WITHOUT CLAIM TO ANY PARTICULAR FONT, STYLE, SIZE, OR COLOR.

THE WORDING "DIVOTI" HAS NO MEANING IN A FOREIGN LANGUAGE.

CLASS 5—PHARMACEUTICALS

FOR MAGNETIC BRACELETS FOR MEDICAL PURPOSES (U.S. CLS. 6, 18, 44, 46, 51 AND 52).

FIRST USE 10-1-2011; IN COMMERCE 10-1-2011.

CLASS 10—MEDICAL APPARATUS

FOR APPARATUS FOR MAGNET THERAPY; MAGNETS FOR MEDICAL PURPOSES (U.S. CLS. 26, 39 AND 44).

FIRST USE 10-1-2011; IN COMMERCE 10-1-2011.

4,119,367. DONG WU INVESTMENT CO., LTD., TAIPEI COUNTY 248, TAIWAN. SN 85-193,039. PUB. 4-26-2011, FILED 12-8-2010.

4,119,366. DONG WU INVESTMENT CO., LTD., TAIPEI COUNTY 248, TAIWAN. SN 85-193,029. PUB. 4-26-2011, FILED 12-8-2010.



THE MARK CONSISTS OF FOUR SMALL SQUARES FORMING A BIGGER SQUARE INSIDE OF A CIRCLE.

CLASS 36—INSURANCE AND FINANCIAL

FOR INVESTMENT ADVICE; INVESTMENT BROKERAGE; INVESTMENT CONSULTATION; INVESTMENT MANAGEMENT; INVESTMENT OF FUNDS FOR OTHERS; REAL ESTATE AGENCIES; REAL ESTATE INVESTMENT; REAL ESTATE BROKERAGE (U.S. CLS. 100, 101 AND 102).

FIRST USE 6-1-2011; IN COMMERCE 6-1-2011.

CLASS 37—CONSTRUCTION AND REPAIR

FOR CONSTRUCTION AND REPAIR OF BUILDINGS; HOUSE BUILDING AND REPAIR; LAND DEVELOPMENT SERVICES, NAMELY, PLANNING AND LAYING OUT OF RESIDENTIAL AND/OR COMMERCIAL COMMUNITIES; REAL ESTATE DEVELOPMENT (U.S. CLS. 100, 103 AND 106).

FIRST USE 6-1-2011; IN COMMERCE 6-1-2011.



THE MARK CONSISTS OF THE WORD "LIHPAO" IN CAPITAL LETTERS WITH THE VERTICAL LINE OF THE LETTER "L" COMPOSED OF FIVE RECTANGLES ADJACENT TO SEVEN RECTANGLES ALIGNED VERTICALLY COMPOSING A BUILDING-LIKE FIGURE. THE WORD AND THE BUILDING DESIGN ARE UNDERLINED BY TWO LINES, ONE THICKER THAN THE OTHER.

CLASS 36—INSURANCE AND FINANCIAL

FOR INVESTMENT ADVICE; INVESTMENT BROKERAGE; INVESTMENT CONSULTATION; INVESTMENT MANAGEMENT; INVESTMENT OF FUNDS FOR OTHERS; REAL ESTATE AGENCIES; REAL ESTATE INVESTMENT; REAL ESTATE BROKERAGE (U.S. CLS. 100, 101 AND 102).

FIRST USE 6-1-2011; IN COMMERCE 6-1-2011.

CLASS 37—CONSTRUCTION AND REPAIR

FOR CONSTRUCTION AND REPAIR OF BUILDINGS; HOUSE BUILDING AND REPAIR; LAND DEVELOPMENT SERVICES, NAMELY, PLANNING AND LAYING OUT OF RESIDENTIAL AND/OR COMMERCIAL COMMUNITIES; REAL ESTATE DEVELOPMENT (U.S. CLS. 100, 103 AND 106).

FIRST USE 6-1-2011; IN COMMERCE 6-1-2011.

4,119,370. THE F. L. EMMERT CO., CINCINNATI, OH. SN 85-194,494. PUB. 5-10-2011, FILED 12-9-2010.



NO CLAIM IS MADE TO THE EXCLUSIVE RIGHT TO USE "COMPANY" AND "QUALITY NUTRITION SINCE 1881", APART FROM THE MARK AS SHOWN.

THE NAME "F. L. EMMERT" DOES NOT IDENTIFY A LIVING INDIVIDUAL.

THE MARK CONSISTS OF THE LARGE, STYLIZED WORD "EMMERT" WITH A PIECE OF GRAIN FORMING PART OF THE SECOND "M", WITH THE LETTERS "F. L." TO THE ABOVE RIGHT AND THE WORDS "COMPANY QUALITY NUTRITION SINCE 1881".

CLASS 5—PHARMACEUTICALS

FOR DIETARY AND NUTRITIONAL SUPPLEMENTS
(U.S. CLS. 6, 18, 44, 46, 51 AND 52).
FIRST USE 10-0-2010; IN COMMERCE 10-0-2010.

4,119,394. AMTROL LICENSING INC., WEST WARWICK,
RI. SN 85-198,711. PUB. 7-26-2011, FILED 12-15-2010.

CLASS 31—NATURAL AGRICULTURAL PRODUCTS

FOR NUTRITIONAL ANIMAL FOOD ADDITIVES,
NOT FOR MEDICAL USE (U.S. CLS. 1 AND 46).
FIRST USE 10-0-2010; IN COMMERCE 10-0-2010.

4,119,380. THE UNIVERSITY OF NEW MEXICO, ALBU-
QUERQUE, NM. SN 85-196,700. PUB. 5-10-2011, FILED
12-13-2010.



THE COLOR(S) RED, BLACK, WHITE, BROWN AND
GREY IS/ARE CLAIMED AS A FEATURE OF THE MARK.
THE MARK CONSISTS OF THE WORDING "LOBO
LUCY" IN WHITE WITH A BLACK AND RED OUTLINE
AND THE DESIGN AND A LOBO HEAD IN GRAY AND
BLACK WITH BROWN EYES, WHITE TEETH AND A RED
HAIR BOW, LIPSTICK AND TONGUE.

CLASS 25—CLOTHING

FOR SHIRTS (U.S. CLS. 22 AND 39).
FIRST USE 12-0-2010; IN COMMERCE 12-0-2010.

CLASS 41—EDUCATION AND ENTERTAINMENT

FOR ENTERTAINMENT IN THE NATURE OF COM-
PETITIONS IN THE FIELD OF COLLEGIATE ATHLETIC
EVENTS; FAN CLUBS (U.S. CLS. 100, 101 AND 107).
FIRST USE 2-12-2010; IN COMMERCE 2-12-2010.

OWNER OF U.S. REG. NOS. 871,142, 2,623,669, AND
2,623,674.

THE MARK CONSISTS OF A TRIANGLE WITH THE
STYLIZED LETTERS A AND T APPEARING WITHIN THE
TRIANGLE.

CLASS 6—METAL GOODS

FOR WATER STORAGE TANKS, NAMELY, METAL
FLUID STORAGE TANKS; PRESSURIZED STORAGE
TANKS FOR WELL-WATER SYSTEMS, NAMELY, ME-
TAL FLUID STORAGE TANKS; METAL WATER STOR-
AGE TANKS AND WATER PUMP CONTROL DEVICES
SOLD AS A UNIT; METAL VALVES NOT BEING PARTS
OF MACHINES; METAL CYLINDERS FOR COM-
PRESSED GAS, SOLD EMPTY; METAL PIPE HANGERS;
METAL PIPE CLIPS; METAL REFRIGERANT RECOV-
ERY CYLINDERS, NAMELY, METAL FLUID STORAGE
TANKS (U.S. CLS. 2, 12, 13, 14, 23, 25 AND 50).
FIRST USE 1-3-2011; IN COMMERCE 1-3-2011.

CLASS 9—ELECTRICAL AND SCIENTIFIC APPARATUS

FOR ELECTROMECHANICAL CONTROLS FOR USE
IN WATER PUMP SYSTEMS; FIRE EXTINGUISHING
APPARATUS; AND EXPANSION TANKS FOR USE IN
SPRINKLER SYSTEMS FOR FIRE PROTECTION (U.S.
CLS. 21, 23, 26, 36 AND 38).
FIRST USE 1-3-2011; IN COMMERCE 1-3-2011.

CLASS 11—ENVIRONMENTAL CONTROL APPARATUS

FOR APPARATUS FOR HEATING AND WATER SUPPLY PURPOSES, NAMELY, HEATING INSTALLATIONS, HOT WATER TANKS, WATER PRESSURE REGULATORS FOR WATER INSTALLATIONS, REGULATING ACCESSORIES FOR HOT WATER SUPPLY IN THE NATURE OF METERED VALVES; WATER STORAGE TANKS BEING PARTS OF PLUMBING AND HEATING AND COOLING INSTALLATIONS, NAMELY, HOT WATER TANKS, WELL WATER TANKS, AND WATER RETENTION TANKS; WATER PRESSURE BOOSTER SYSTEMS PRIMARILY COMPOSED OF A PUMP AND A DIAPHRAGM TANK, AS PART OF PLUMBING AND HEATING AND COOLING INSTALLATIONS; PRESSURIZED WATER STORAGE TANKS AS A COMPONENT OF WELL-WATER SYSTEMS; METAL WATER STORAGE TANKS BEING PARTS OF PLUMBING AND HEATING AND COOLING INSTALLATIONS, NAMELY, DIAPHRAGM TANKS AND WATER PUMP CONTROL DEVICES SOLD AS A UNIT; EXPANSION TANKS FOR USE IN HEATING SYSTEMS; VALVES FOR PLUMBING AND HEATING AND COOLING INSTALLATIONS, NAMELY, THERMOSTATIC VALVES AND PRESSURE-REDUCING VALVES IN PLUMBING AND HEATING AND COOLING INSTALLATIONS; WATER HEATERS; INDIRECT-FIRED WATER HEATERS; SHOCK SUPPRESSORS FOR PLUMBING AND HEATING INSTALLATIONS; AIR VENTS, NAMELY, AIR VENTS FOR HOT WATER HEATING SYSTEMS; AIR PURGERS, NAMELY, AIR PURGERS FOR HOT WATER HEATING SYSTEMS; AND AIR SEPARATORS, NAMELY, AIR SEPARATORS FOR HOT WATER HEATING SYSTEMS (U.S. CLS. 13, 21, 23, 31 AND 34).
FIRST USE 1-3-2011; IN COMMERCE 1-3-2011.

4,119,399. S. C. JOHNSON & SON, INC., RACINE, WI. SN 85-199,307. PUB. 6-7-2011, FILED 12-16-2010.

SPICED CITRUS CHIC

THE MARK CONSISTS OF STANDARD CHARACTERS WITHOUT CLAIM TO ANY PARTICULAR FONT, STYLE, SIZE, OR COLOR.

NO CLAIM IS MADE TO THE EXCLUSIVE RIGHT TO USE "CITRUS", APART FROM THE MARK AS SHOWN.

CLASS 4—LUBRICANTS AND FUELS

FOR CANDLES (U.S. CLS. 1, 6 AND 15).
FIRST USE 12-2-2011; IN COMMERCE 12-2-2011.

CLASS 5—PHARMACEUTICALS

FOR AIR FRESHENERS (U.S. CLS. 6, 18, 44, 46, 51 AND 52).
FIRST USE 10-28-2011; IN COMMERCE 10-28-2011.

4,119,398. TRIVANI INTERNATIONAL, LLC, SPRINGVILLE, UT. SN 85-199,240. PUB. 5-17-2011, FILED 12-16-2010.

TrivanThin

THE MARK CONSISTS OF STANDARD CHARACTERS WITHOUT CLAIM TO ANY PARTICULAR FONT, STYLE, SIZE, OR COLOR.

NO CLAIM IS MADE TO THE EXCLUSIVE RIGHT TO USE "THIN", APART FROM THE MARK AS SHOWN.

CLASS 5—PHARMACEUTICALS

FOR DIETARY AND NUTRITIONAL SUPPLEMENTS USED FOR WEIGHT LOSS; DIETARY SUPPLEMENTAL DRINKS IN THE NATURE OF VITAMIN AND MINERAL BEVERAGES; LIQUID NUTRITIONAL SUPPLEMENT; LIQUID VITAMIN SUPPLEMENTS; VITAMIN AND MINERAL SUPPLEMENTS (U.S. CLS. 6, 18, 44, 46, 51 AND 52).
FIRST USE 4-28-2011; IN COMMERCE 4-28-2011.

CLASS 32—LIGHT BEVERAGES

FOR DRINKING WATER WITH VITAMINS; FLAVORED BOTTLED WATER (U.S. CLS. 45, 46 AND 48).
FIRST USE 4-28-2011; IN COMMERCE 4-28-2011.

4,119,406. TRIBRIDGE RESIDENTIAL, LLC, ATLANTA, GA. SN 85-201,575. PUB. 5-10-2011, FILED 12-20-2010.

TRIBRIDGE RESIDENTIAL

THE MARK CONSISTS OF STANDARD CHARACTERS WITHOUT CLAIM TO ANY PARTICULAR FONT, STYLE, SIZE, OR COLOR.

NO CLAIM IS MADE TO THE EXCLUSIVE RIGHT TO USE "RESIDENTIAL", APART FROM THE MARK AS SHOWN.

CLASS 36—INSURANCE AND FINANCIAL

FOR MANAGEMENT OF APARTMENTS; REAL ESTATE SERVICE, NAMELY, RENTAL PROPERTY MANAGEMENT; REAL ESTATE SERVICES, NAMELY, CONDOMINIUM MANAGEMENT SERVICES; REAL ESTATE SERVICES, NAMELY, PROPERTY MANAGEMENT SERVICES FOR CONDOMINIUM ASSOCIATIONS, HOMEOWNER ASSOCIATIONS AND APARTMENT BUILDINGS (U.S. CLS. 100, 101 AND 102).
FIRST USE 12-7-2010; IN COMMERCE 12-7-2010.

CLASS 37—CONSTRUCTION AND REPAIR

FOR CONSTRUCTION AND RENOVATION OF BUILDINGS; CONSTRUCTION MANAGEMENT; REAL ESTATE DEVELOPMENT (U.S. CLS. 100, 103 AND 106).
FIRST USE 12-7-2010; IN COMMERCE 12-7-2010.

4,119,417. PACIFIC SUNWEAR OF CALIFORNIA, INC., ANAHEIM, CA. SN 85-202,940. PUB. 5-10-2011, FILED 12-21-2010.

BLACK POPPY

THE MARK CONSISTS OF STANDARD CHARACTERS WITHOUT CLAIM TO ANY PARTICULAR FONT, STYLE, SIZE, OR COLOR.

OWNER OF U.S. REG. NOS. 3,835,985 AND 3,881,036.

CLASS 18—LEATHER GOODS

FOR HANDBAGS, TOTE BAGS, BEACH BAGS, MESSENGER BAGS, BACKPACKS, COIN PURSES, PURSES, CLUTCHES (U.S. CLS. 1, 2, 3, 22 AND 41).

FIRST USE 1-1-2010; IN COMMERCE 1-1-2010.

CLASS 25—CLOTHING

FOR CLOTHING, NAMELY, SHIRTS, T-SHIRTS, WOVEN SHIRTS, FLANNEL SHIRTS, KNIT TOPS, TANK TOPS, DRESSES, SKIRTS, SWEATSHIRTS, JACKETS, SWEATERS, SCARVES, SHAWLS, BELTS, GLOBES, MITTENS, SOCKS; FOOTWEAR, NAMELY, CASUAL FOOTWEAR, SHOES, SANDALS, SLIPPERS, BOOTS; HEADGEAR, NAMELY, HATS, CAPS, VISORS, BEANIES AND HEAD BANDS (U.S. CLS. 22 AND 39).

FIRST USE 1-1-2010; IN COMMERCE 1-1-2010.

4,119,420. PACIFIC SUNWEAR OF CALIFORNIA, INC., ANAHEIM, CA. SN 85-202,985. PUB. 5-10-2011, FILED 12-21-2010.

PACSUN

THE MARK CONSISTS OF STANDARD CHARACTERS WITHOUT CLAIM TO ANY PARTICULAR FONT, STYLE, SIZE, OR COLOR.

OWNER OF U.S. REG. NOS. 1,613,010, 2,579,269, AND OTHERS.

CLASS 25—CLOTHING

FOR CLOTHING, NAMELY, SHIRTS, T-SHIRTS, WOVEN SHIRTS, FLANNEL SHIRTS, KNIT TOPS, TANK TOPS, DRESSES, SKIRTS, SWEATSHIRTS, SWEAT PANTS, PANTS, JEANS, LEGGINGS, SHORTS, JACKETS, SWEATERS, PAJAMAS, UNDER GARMENTS, SWIM SUITS, SWIM WEAR, SCARVES, SHAWLS, BELTS, GLOVES, MITTENS, SOCKS; FOOTWEAR, NAMELY, CASUAL FOOTWEAR, ATHLETIC FOOTWEAR, SHOES, SANDALS, SLIPPERS, BOOTS, BEACH FOOTWEAR; HEADGEAR, NAMELY, HATS, CAPS, VISORS, BEANIES AND HEAD BANDS (U.S. CLS. 22 AND 39).

FIRST USE 10-21-1987; IN COMMERCE 10-21-1987.

CLASS 35—ADVERTISING AND BUSINESS

FOR RETAIL STORE AND ONLINE RETAIL STORE SERVICES IN THE FIELDS OF CLOTHING, HEADWEAR, FOOTWEAR, BAGS, COSMETICS, EYEWEAR, WATCHES, JEWELRY, SKATEBOARDS AND CONSUMER ELECTRONICS (U.S. CLS. 100, 101 AND 102).

FIRST USE 11-27-1999; IN COMMERCE 11-27-1999.

4,119,421. PACIFIC SUNWEAR OF CALIFORNIA, INC., ANAHEIM, CA. SN 85-202,988. PUB. 5-10-2011, FILED 12-21-2010.

PACSUN

OWNER OF U.S. REG. NOS. 1,613,010, 2,579,269, AND OTHERS.

THE MARK CONSISTS OF THE STYLIZED WORDING "PACSUN".

CLASS 25—CLOTHING

FOR CLOTHING, NAMELY, SHIRTS, T-SHIRTS, WOVEN SHIRTS, FLANNEL SHIRTS, KNIT TOPS, TANK TOPS, DRESSES, SKIRTS, SWEATSHIRTS, SWEAT PANTS, PANTS, JEANS, LEGGINGS, SHORTS, JACKETS, SWEATERS, PAJAMAS, UNDER GARMENTS, SWIM SUITS, SWIM WEAR, SCARVES, SHAWLS, BELTS, GLOVES, MITTENS, SOCKS; FOOTWEAR, NAMELY, CASUAL FOOTWEAR, ATHLETIC FOOTWEAR, SHOES, SANDALS, SLIPPERS, BOOTS, BEACH FOOTWEAR; HEADGEAR, NAMELY, HATS, CAPS, VISORS, BEANIES AND HEAD BANDS (U.S. CLS. 22 AND 39).

FIRST USE 10-21-1987; IN COMMERCE 10-21-1987.

CLASS 35—ADVERTISING AND BUSINESS

FOR RETAIL STORE AND ONLINE RETAIL STORE SERVICES IN THE FIELDS OF CLOTHING, HEADWEAR, FOOTWEAR, BAGS, COSMETICS, EYEWEAR, WATCHES, JEWELRY, SKATEBOARDS AND CONSUMER ELECTRONICS (U.S. CLS. 100, 101 AND 102).

FIRST USE 11-27-1999; IN COMMERCE 11-27-1999.

4,119,425. BEATPORT, LLC, DENVER, CO. SN 85-204,693. PUB. 6-14-2011, FILED 12-23-2010.

PLAY WITH MUSIC

THE MARK CONSISTS OF STANDARD CHARACTERS WITHOUT CLAIM TO ANY PARTICULAR FONT, STYLE, SIZE, OR COLOR.

CLASS 9—ELECTRICAL AND SCIENTIFIC APPARATUS

FOR DOWNLOADABLE COMPUTER SOFTWARE USED TO PERSONALIZE MUSIC TO EXPRESS INDIVIDUAL STYLES VIA A GLOBAL COMPUTER NETWORK AND WIRELESS DEVICES (U.S. CLS. 21, 23, 26, 36 AND 38).

FIRST USE 12-1-2009; IN COMMERCE 12-1-2009.

CLASS 42—SCIENTIFIC AND COMPUTER SERVICES

FOR PROVIDING TEMPORARY USE OF NON-DOWNLOADABLE COMPUTER SOFTWARE USED FOR ENTERTAINMENT PURPOSES, NAMELY, TO PERSONALIZE MUSIC TO EXPRESS INDIVIDUAL STYLES VIA A GLOBAL COMPUTER NETWORK AND WIRELESS DEVICES (U.S. CLS. 100 AND 101).

FIRST USE 12-1-2009; IN COMMERCE 12-1-2009.

4,119,432. PAYDIVVY, INC., IRVINE, CA. SN 85-207,329. PUB. 5-24-2011, FILED 12-29-2010.

PAYDIVVY

THE MARK CONSISTS OF STANDARD CHARACTERS WITHOUT CLAIM TO ANY PARTICULAR FONT, STYLE, SIZE, OR COLOR.

CLASS 35—ADVERTISING AND BUSINESS

FOR BILL MANAGEMENT SERVICES, NAMELY, TRACKING, REPORTING AND ANALYZING BILLING INFORMATION FOR OTHERS (U.S. CLS. 100, 101 AND 102).

FIRST USE 8-1-2011; IN COMMERCE 8-1-2011.

CLASS 36—INSURANCE AND FINANCIAL

FOR BILL PAYMENT SERVICES; ELECTRONIC TRANSFER OF MONEY; MEMBERSHIP DUES COLLECTION SERVICES; CHARITABLE DONATION COLLECTION SERVICES (U.S. CLS. 100, 101 AND 102).

FIRST USE 8-1-2011; IN COMMERCE 8-1-2011.

4,119,440. SHIPLEY GROUP, L.P., YORK, PA. SN 85-209,393. PUB. 5-10-2011, FILED 1-3-2011.

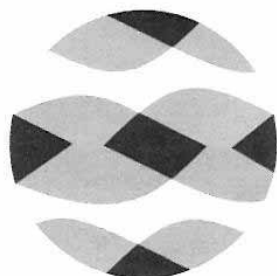

THE MARK CONSISTS OF A CIRCULAR ARRANGEMENT OF UPPER, MIDDLE AND LOWER GENERALLY HORIZONTAL ELEMENTS, THE MIDDLE ELEMENT SE-

PARATED FROM THE UPPER AND LOWER ELEMENTS BY GENERALLY HORIZONTAL SPACES, EACH ELEMENT COMPRISING TWO PARTIALLY OVERLAPPING SEGMENTS WITH THE AREA OF OVERLAP INDICATED BY DIFFERENT SHADING, THE OUTER PORTION OF EACH SEGMENT OF THE MIDDLE ELEMENT FURTHER INCLUDING A GENERALLY TRIANGULAR AREA BEING SHADED THE SAME AS THE SHADING USED FOR AREAS OF OVERLAP.

CLASS 35—ADVERTISING AND BUSINESS

FOR RESELLER SERVICES, NAMELY, DISTRIBUTORSHIP SERVICES IN THE FIELD OF HEATING OIL, NATURAL GAS, AND PROPANE; WHOLESALE DISTRIBUTORSHIPS FEATURING GASOLINE AND OTHER LIQUID FUELS FOR SALE BY SERVICE STATIONS (U.S. CLS. 100, 101 AND 102).

FIRST USE 1-0-2011; IN COMMERCE 1-0-2011.

CLASS 36—INSURANCE AND FINANCIAL

FOR BROKERAGE OF ENERGY, NAMELY, GAS AND ELECTRICITY (U.S. CLS. 100, 101 AND 102).

FIRST USE 1-0-2011; IN COMMERCE 1-0-2011.

CLASS 37—CONSTRUCTION AND REPAIR

FOR HVAC CONTRACTOR SERVICES; VEHICLE FUELING SERVICES (U.S. CLS. 100, 103 AND 106).

FIRST USE 1-0-2011; IN COMMERCE 1-0-2011.

CLASS 39—TRANSPORTATION AND STORAGE

FOR FUEL DELIVERY SERVICES FEATURING HEATING OIL, NATURAL GAS, AND PROPANE (U.S. CLS. 100 AND 105).

FIRST USE 1-0-2011; IN COMMERCE 1-0-2011.

4,119,447. STONYFIELD FARM, INC., LONDONDERRY, NH. SN 85-210,895. PUB. 5-24-2011, FILED 1-5-2011.

LOVE ON A SPOON

THE MARK CONSISTS OF STANDARD CHARACTERS WITHOUT CLAIM TO ANY PARTICULAR FONT, STYLE, SIZE, OR COLOR.

CLASS 5—PHARMACEUTICALS

FOR BABY FOOD (U.S. CLS. 6, 18, 44, 46, 51 AND 52). FIRST USE 10-20-2011; IN COMMERCE 10-20-2011.

CLASS 29—MEATS AND PROCESSED FOODS

FOR DAIRY PRODUCTS EXCLUDING ICE CREAM, ICE MILK AND FROZEN YOGURT (U.S. CL. 46). FIRST USE 10-20-2011; IN COMMERCE 10-20-2011.

4,119,451. LIQUIDPLANNER, INC., BELLEVUE, WA. SN 85-212,270. PUB. 8-2-2011, FILED 1-6-2011.



OWNER OF U.S. REG. NO. 3,513,371.

THE MARK CONSISTS OF THREE STACKED WAVY LINES TO THE LEFT OF THE WORD "LIQUIDPLANNER".

CLASS 39—TRANSPORTATION AND STORAGE

FOR SERVICES, NAMELY, PROVIDING REMOTE STORAGE OF USER'S ELECTRONIC AND DIGITAL FILES (U.S. CLS. 100 AND 105).
FIRST USE 6-4-2011; IN COMMERCE 6-4-2011.

CLASS 42—SCIENTIFIC AND COMPUTER SERVICES

FOR APPLICATION SERVICE PROVIDER (ASP), NAMELY, HOSTING COMPUTER SOFTWARE APPLICATIONS OF OTHERS; APPLICATION SERVICE PROVIDER (ASP) FEATURING SOFTWARE A FOR MANAGING PROJECTS, PROCESSES, WORK FLOW, AND SOFTWARE PROJECTS; PROVIDING TEMPORARY USE OF ON-LINE NON-DOWNLOADABLE SOFTWARE FOR MANAGING PROJECTS, PROCESSES, WORK FLOW, AND SOFTWARE PROJECTS; APPLICATION SERVICE PROVIDER (ASP) FEATURING SOFTWARE FOR COLLABORATIVE WORK AMONG COMPUTER SYSTEM USERS FOR COLLABORATIVE EDITING AND COMMUNICATION BETWEEN COMPUTER SYSTEM USERS; PROVIDING TEMPORARY USE OF ON-LINE NON-DOWNLOADABLE SOFTWARE FOR COLLABORATIVE WORK AMONG COMPUTER SYSTEM USERS FOR COLLABORATIVE EDITING AND COMMUNICATION BETWEEN COMPUTER SYSTEM USERS; APPLICATION SERVICE PROVIDER (ASP) FEATURING SOFTWARE FOR STORING, CATALOGUING, ORGANIZING, AND ACCESSING DIGITAL CONTENT, INFORMATION, DATA, TEXT, FILES, AND DOCUMENTS; PROVIDING TEMPORARY USE OF ON-LINE NON-DOWNLOADABLE SOFTWARE FOR STORING, CATALOGUING, ORGANIZING, AND ACCESSING DIGITAL CONTENT, INFORMATION, DATA, TEXT, FILES, AND DOCUMENTS; COMPUTER PROJECT MANAGEMENT SERVICES; HOSTING OF DIGITAL CONTENT, INFORMATION, DATA, TEXT, FILES AND DOCUMENTS FOR OTHERS ON THE INTERNET; TECHNICAL SUPPORT SERVICES, NAMELY, TROUBLESHOOTING OF COMPUTER SOFTWARE PROBLEMS AND WEB APPLICATIONS (U.S. CLS. 100 AND 101).

FIRST USE 6-4-2011; IN COMMERCE 6-4-2011.

4,119,463. JOHN B. SANFILIPPO & SON, INC., ELGIN, IL. SN 85-215,233. PUB. 5-24-2011, FILED 1-11-2011.



THE MARK CONSISTS OF STANDARD CHARACTERS WITHOUT CLAIM TO ANY PARTICULAR FONT, STYLE, SIZE, OR COLOR.

OWNER OF U.S. REG. NOS. 3,923,218, 3,923,220, AND

OTHERS.

NO CLAIM IS MADE TO THE EXCLUSIVE RIGHT TO USE "ENERGY" IN INTERNATIONAL CLASSES 29 AND 30, APART FROM THE MARK AS SHOWN.

THE ENGLISH TRANSLATION OF THE WORD "ARMA" IN THE MARK IS WEAPON.

CLASS 16—PAPER GOODS AND PRINTED MATTER

FOR STICKERS AND DECALCOMANIAS (U.S. CLS. 2, 5, 22, 23, 29, 37, 38 AND 50).
FIRST USE 7-29-2010; IN COMMERCE 7-29-2010.

CLASS 18—LEATHER GOODS

FOR TOTE BAGS, LUGGAGE, BACKPACKS AND UMBRELLAS (U.S. CLS. 1, 2, 3, 22 AND 41).
FIRST USE 7-29-2010; IN COMMERCE 7-29-2010.

CLASS 25—CLOTHING

FOR CLOTHING, NAMELY, SHIRTS, HATS, PANTS, BOXER BRIEFS, BOXER SHORTS AND FOOTWEAR (U.S. CLS. 22 AND 39).
FIRST USE 2-0-2010; IN COMMERCE 4-16-2010.

CLASS 29—MEATS AND PROCESSED FOODS

FOR SHELLED, PROCESSED NUTS AND FLAVORED NUTS; NUTS INFUSED WITH VITAMINS; NUTS INFUSED WITH MINERALS; NUTS INFUSED WITH CAFFEINE; DRIED FRUITS; DRIED FRUITS INFUSED WITH VITAMINS; DRIED FRUITS INFUSED WITH MINERALS; DRIED FRUITS INFUSED WITH CAFFEINE; SNACK MIXES CONSISTING OF COMBINATIONS OF PROCESSED NUTS AND FLAVORED NUTS AND DRIED FRUITS; CANDIED FRUITS, NAMELY, RAISINS; CANDIED FLAVORED NUTS; CANDIED FLAVORED NUTS INFUSED WITH VITAMINS, MINERALS AND/OR CAFFEINE; PRESERVED SOYA BEANS FOR FOOD INFUSED WITH VITAMINS, MINERALS AND/OR CAFFEINE; FOODSTUFFS IN THE FORM OF POTATO STICKS, ALL MADE PRINCIPALLY OF FLOUR AND ALL BEING FLAVORED ALL PREPARED AND INFUSED WITH VITAMINS, MINERALS AND/OR CAFFEINE (U.S. CL. 46).

FIRST USE 7-29-2010; IN COMMERCE 8-18-2010.

CLASS 30—STAPLE FOODS

FOR SNACK MIXES CONSISTING PRIMARILY OF CRACKERS AND PRETZELS AND ALSO CONTAINING PROCESSED NUTS WITHOUT SHELLS AND NUTS THAT ARE PROCESSED, ROASTED, SALTED, FLAVORED AND CANDY-COVERED OR CHOCOLATE COVERED, AS WELL AS CANDIED FRUIT AND MARSHMALLOWS, THE SNACK MIXES BEING INFUSED WITH VITAMINS, MINERALS AND/OR CAFFEINE; SWEETENED YOGURT COVERED RAISINS INFUSED WITH VITAMINS, MINERALS AND/OR CAFFEINE; CANDIES INFUSED WITH VITAMINS, MINERALS AND/OR CAFFEINE; CHOCOLATE COVERED NUTS INFUSED WITH VITAMINS, MINERALS AND/OR CAFFEINE; CHOCOLATE COVERED FRUITS INFUSED WITH VITAMINS, MINERALS AND/OR CAFFEINE; RAISINS DIPPED IN YOGURT AND INFUSED WITH VITAMINS, MINERALS AND/OR CAFFEINE; MARSHMALLOWS; CHEESE FLAVORED PUFFED CORN SNACKS; PUFFED CORN SNACKS; POPPED POPCORN; POPCORN GLAZED, CARAMEL OR CANDY-COATED AND MIXTURES THEREOF; COOKIES; PRETZELS; GRANOLA-BASED SNACK CLUSTERS AND BARS INFUSED WITH VITAMINS, MINERALS AND/OR CAFFEINE; FOODSTUFFS IN THE FORM OF BREAD STICKS, SESAME STICKS, CORN CHIPS, AND FLOUR-BASED CHIPS, ALL MADE PRINCIPALLY OF FLOUR AND ALL BEING FLAVORED ALL PREPARED AND INFUSED WITH VITAMINS, MINERALS AND/OR CAFFEINE; SESAME FLAVORED SNACKS IN STICK FORM CONTAINING WHEAT FLOUR AND INFUSED WITH VITAMINS, MINERALS AND/OR CAFFEINE; AND BREAD STICKS MADE PRIMARILY FROM WHEAT FLOUR, VEGETABLE OIL, SESAME SEEDS, AND OTHER FLAVORINGS AND COLORING INGREDIENTS AND INFUSED WITH VITAMINS, MINERALS AND/OR CAFFEINE (U.S. CL. 46).

FIRST USE 7-29-2010; IN COMMERCE 8-18-2010.

CLASS 21—HOUSEWARES AND GLASS

FOR HAIR STYLING ACCESSORIES, NAMELY, HAIR COMBS; HAIR COLORING ACCESSORIES, NAMELY, HAIR COLORING BRUSH AND HAIR COLOR APPLICATION BOWLS (U.S. CLS. 2, 13, 23, 29, 30, 33, 40 AND 50).

FIRST USE 3-31-2011; IN COMMERCE 3-31-2011.

CLASS 25—CLOTHING

FOR SHAMPOO CAPES (U.S. CLS. 22 AND 39).
FIRST USE 3-31-2011; IN COMMERCE 3-31-2011.

CLASS 26—FANCY GOODS

FOR HAIR STYLING ACCESSORIES, NAMELY, CLAW CLIPS AND HAIR ORNAMENTS IN THE FORM OF COMBS; HAIR CLIPS (U.S. CLS. 37, 39, 40, 42 AND 50).

FIRST USE 3-31-2011; IN COMMERCE 3-31-2011.

4,119,492. COUTURE COLOUR LLC, LOS ANGELES, CA. SN 85-222,412. PUB. 5-31-2011, FILED 1-20-2011.

4,119,495. CONNECTIONS EDUCATION, LLC, BALTIMORE, MD. SN 85-223,587. PUB. 6-28-2011, FILED 1-21-2011.

COUTURE COLOUR

THE MARK CONSISTS OF STANDARD CHARACTERS WITHOUT CLAIM TO ANY PARTICULAR FONT, STYLE, SIZE, OR COLOR.

NO CLAIM IS MADE TO THE EXCLUSIVE RIGHT TO USE "COLOUR" IN INTERNATIONAL CLASSES 3, 21, 25, AND 26, APART FROM THE MARK AS SHOWN.

CLASS 3—COSMETICS AND CLEANING PREPARATIONS

FOR SHAMPOOS, CONDITIONERS AND NON-MEDICATED HAIR TREATMENT OILS (U.S. CLS. 1, 4, 6, 50, 51 AND 52).

FIRST USE 3-31-2011; IN COMMERCE 3-31-2011.

CLASS 11—ENVIRONMENTAL CONTROL APPARATUS

FOR PLUMBING FITTINGS, NAMELY, SHOWER FAUCET FILTERS (U.S. CLS. 13, 21, 23, 31 AND 34).

FIRST USE 3-31-2011; IN COMMERCE 3-31-2011.

CONNECTIONS LEARNING

THE MARK CONSISTS OF STANDARD CHARACTERS WITHOUT CLAIM TO ANY PARTICULAR FONT, STYLE, SIZE, OR COLOR.

OWNER OF U.S. REG. NOS. 2,776,687, 3,888,523, AND 3,891,782.

NO CLAIM IS MADE TO THE EXCLUSIVE RIGHT TO USE "LEARNING", APART FROM THE MARK AS SHOWN.

CLASS 41—EDUCATION AND ENTERTAINMENT

FOR EDUCATIONAL SERVICES, NAMELY, OPERATING A VIRTUAL SCHOOL FOR GRADES K-12; EDUCATIONAL SERVICES, NAMELY, PROVIDING TEACHING AT THE GRADE K-12 LEVEL; EDUCATIONAL SERVICES, NAMELY, PROVIDING ACADEMIC PERFORMANCE EVALUATION, GUIDANCE AND MONITORING FOR CHILDREN AT GRADE K-12 VIA THE INTERNET; EDUCATIONAL SERVICES, NAMELY, PROVIDING ONLINE COURSES OF INSTRUCTION AT THE K-12 LEVEL AND PRINTED MATERIALS DISTRIBUTED THEREWITH; EDUCATIONAL PRODUCTS, NAMELY, PROVIDING ONLINE CURRICULUM COURSE MATERIALS FOR STUDENTS AT THE GRADE K-12 LEVEL; EDUCATIONAL SERVICES, NAMELY, PROVIDING ONLINE EDUCATIONAL PROGRAMS AND DISTANCE LEARNING INSTRUCTION AT THE K-12 LEVEL AND PRINTED COURSE MATERIALS DISTRIBUTED THEREWITH; EDUCATIONAL PRODUCTS, NAMELY, PROVIDING ONLINE FORMS OF ASSESSMENT, AND RELATED PROTOCOLS THAT ASSIST IN EVALUATING LEARNING AT THE K-12 LEVEL; EDUCATIONAL SERVICES TO HOMEBOUND STUDENTS, NAMELY, PROVIDING TEACHING, ONLINE COURSES OF INSTRUCTION AND PRINTED MATERIALS DISTRIBUTED THEREWITH, ONLINE EDUCATIONAL PROGRAMS AND DISTANCE LEARNING INSTRUCTION TO FACILITATE LEARNING AND ASSESSMENT PRIMARILY THROUGH THE USE OF THE INTERNET; EDUCATIONAL SERVICES TO STUDENTS WITH EMOTIONAL OR PHYSICAL DISABILITIES, NAMELY, PROVIDING TEACHING, ONLINE COURSES OF INSTRUCTION AND PRINTED MATERIALS DISTRIBUTED THEREWITH, ONLINE EDUCATIONAL PROGRAMS AND DISTANCE LEARNING INSTRUCTION, ASSESSMENT, LESSON MODIFICATION AND OTHER ASPECTS OF DELIVERING THESE SERVICES PRIMARILY THROUGH THE USE OF THE INTERNET; EDUCATIONAL SERVICES, NAMELY, PROVIDING REMEDIAL PROGRAMS AND TUTORING IN THE FIELDS OF READING, WRITING, SCIENCE, MATH, SOCIAL STUDIES, GEOGRAPHY, HISTORY, ART, LANGUAGE ARTS, AND OTHER SUBJECTS AT THE GRADE K-12 LEVEL; EDUCATIONAL SERVICES, NAMELY, TEACHER AND ADMINISTRATOR TRAINING; EDUCATIONAL SERVICES, NAMELY, DEVELOPING CURRICULUM FOR TEACHERS; EDUCATIONAL SERVICES, NAMELY, PROVIDING CONSULTING SERVICES IN THE FIELD OF ESTABLISHING AND OPERATING VIRTUAL SCHOOLS (U.S. CLS. 100, 101 AND 107).

FIRST USE 2-17-2011; IN COMMERCE 2-17-2011.

CLASS 42—SCIENTIFIC AND COMPUTER SERVICES

FOR PROVIDING ONLINE, NON-DOWNLOADABLE DIGITAL LEARNING SOFTWARE THAT DELIVERS AND MANAGES TEACHING, COURSE CONTENT, ASSESSMENT, COMMUNICATIONS, ORDERING, ASSET MANAGEMENT, DOCUMENT RETENTION AND MANAGEMENT AND REPORTING; TECHNOLOGY CUSTOMER SUPPORT SERVICES TO STUDENTS AND FAMILIES VIA PHONE, EMAIL AND ONLINE, NAMELY, TROUBLESHOOTING IN THE NATURE OF DIAGNOSING COMPUTER HARDWARE AND SOFTWARE PROBLEMS AND TROUBLESHOOTING OF COMPUTER SOFTWARE PROBLEMS (U.S. CLS. 100 AND 101).

FIRST USE 2-17-2011; IN COMMERCE 2-17-2011.

4,119,504. MAESTRO LEARNING, INC., CAMBRIDGE, MA. SN 85-225,916. PUB. 5-31-2011, FILED 1-25-2011.

WORDSIZZLER

THE MARK CONSISTS OF STANDARD CHARACTERS WITHOUT CLAIM TO ANY PARTICULAR FONT, STYLE, SIZE, OR COLOR.

CLASS 9—ELECTRICAL AND SCIENTIFIC APPARATUS

FOR COMPUTER APPLICATION SOFTWARE FOR MOBILE PHONES AND COMPUTERS, NAMELY, SOFTWARE FOR GAMES AND EDUCATIONAL GAMES (U.S. CLS. 21, 23, 26, 36 AND 38).

FIRST USE 12-23-2010; IN COMMERCE 12-23-2010.

CLASS 42—SCIENTIFIC AND COMPUTER SERVICES

FOR DESIGN AND DEVELOPMENT FOR OTHERS OF COMPUTER APPLICATION SOFTWARE FOR MOBILE PHONES AND COMPUTERS (U.S. CLS. 100 AND 101).

FIRST USE 8-3-2011; IN COMMERCE 8-3-2011.

4,119,512. RECIPPEEPS, INC., JACKSONVILLE, FL. SN 85-228,999. PUB. 6-7-2011, FILED 1-28-2011.

PantryWiser

THE MARK CONSISTS OF STANDARD CHARACTERS WITHOUT CLAIM TO ANY PARTICULAR FONT, STYLE, SIZE, OR COLOR.

CLASS 38—COMMUNICATION

FOR PROVIDING ONLINE CHAT ROOMS FOR REGISTERED USERS FOR TRANSMISSION OF MESSAGES CONCERNING VIRTUAL COMMUNITIES AND SOCIAL NETWORKING (U.S. CLS. 100, 101 AND 104).

FIRST USE 1-28-2011; IN COMMERCE 1-28-2011.

CLASS 42—SCIENTIFIC AND COMPUTER SERVICES

FOR CUSTOMIZED WEB PAGES FEATURING USER-DEFINED INFORMATION, PERSONAL PROFILES AND INFORMATION (U.S. CLS. 100 AND 101).

FIRST USE 1-28-2011; IN COMMERCE 1-28-2011.

CLASS 45—PERSONAL AND LEGAL SERVICES

FOR ONLINE SOCIAL NETWORKING SERVICES (U.S. CLS. 100 AND 101).

FIRST USE 1-28-2011; IN COMMERCE 1-28-2011.

4,119,513. CONNECTIONS EDUCATION, LLC, BALTIMORE, MD. SN 85-229,050. PUB. 6-28-2011, FILED 1-28-2011.



OWNER OF U.S. REG. NOS. 2,776,687, 3,891,782, AND OTHERS.

NO CLAIM IS MADE TO THE EXCLUSIVE RIGHT TO USE "LEARNING", APART FROM THE MARK AS SHOWN.

THE MARK CONSISTS OF A PERSON WITHIN A CIRCLE AND THE WORDS "CONNECTIONS LEARNING".

CLASS 41—EDUCATION AND ENTERTAINMENT

FOR EDUCATIONAL SERVICES, NAMELY, OPERATING A VIRTUAL SCHOOL FOR GRADES K-12; EDUCATIONAL SERVICES, NAMELY, PROVIDING TEACHING AT THE GRADE K-12 LEVEL; EDUCATIONAL SERVICES, NAMELY, PROVIDING ACADEMIC PERFORMANCE EVALUATION, GUIDANCE AND MONITORING FOR CHILDREN AT GRADE K-12 VIA THE INTERNET; EDUCATIONAL SERVICES, NAMELY, PROVIDING ONLINE COURSES OF INSTRUCTION AT THE K-12 LEVEL AND PRINTED MATERIALS DISTRIBUTED THEREWITH; EDUCATIONAL PRODUCTS, NAMELY, PROVIDING ONLINE CURRICULUM COURSE MATERIALS FOR STUDENTS AT THE GRADE K-12 LEVEL; EDUCATIONAL SERVICES, NAMELY, PROVIDING ONLINE EDUCATIONAL PROGRAMS AND DISTANCE LEARNING INSTRUCTION AT THE K-12 LEVEL AND PRINTED COURSE MATERIALS DISTRIBUTED THEREWITH; EDUCATIONAL PRODUCTS, NAMELY, PROVIDING ONLINE FORMS OF ASSESSMENT, AND RELATED PROTOCOLS THAT ASSIST IN EVALUATING LEARNING AT THE K-12 LEVEL; EDUCATIONAL SERVICES TO HOMEBOUND STUDENTS, NAMELY, PROVIDING TEACHING, ONLINE COURSES OF INSTRUCTION AND PRINTED MATERIALS DISTRIBUTED THEREWITH, ONLINE EDUCATIONAL PROGRAMS AND DISTANCE LEARNING INSTRUCTION TO FACILITATE LEARNING AND ASSESSMENT PRIMARILY THROUGH THE USE OF THE INTERNET; EDUCATIONAL SERVICES TO STUDENTS WITH EMOTIONAL OR PHYSICAL DISABILITIES, NAMELY, PROVIDING TEACHING, ONLINE COURSES OF INSTRUCTION AND PRINTED MATERIALS DISTRIBUTED THEREWITH, ONLINE EDUCATIONAL PROGRAMS AND DISTANCE LEARNING INSTRUCTION, ASSESSMENT, LESSON MODIFICATION AND OTHER ASPECTS OF DELIVERING THESE SERVICES PRIMARILY THROUGH THE USE OF THE INTERNET; EDUCATIONAL SERVICES, NAMELY, PROVIDING REMEDIAL PROGRAMS AND TUTORING IN THE FIELDS OF READING, WRITING, SCIENCE, MATH, SOCIAL STUDIES, GEOGRAPHY, HISTORY, ART, LANGUAGE ARTS, AND OTHER SUBJECTS AT THE GRADE K-12 LEVEL; EDUCATIONAL SERVICES, NAMELY, TEACHER AND ADMINISTRATOR TRAINING; EDUCATIONAL SERVICES, NAMELY, DEVELOPING CURRICULUM FOR TEACHERS; EDUCATIONAL SERVICES, NAMELY, PROVIDING CONSULTING SERVICES IN THE FIELD OF ESTABLISHING AND OPERATING VIRTUAL SCHOOLS (U.S. CLS. 100, 101 AND 107).

FIRST USE 2-17-2011; IN COMMERCE 2-17-2011.

CLASS 42—SCIENTIFIC AND COMPUTER SERVICES

FOR PROVIDING ONLINE, NON-DOWNLOADABLE DIGITAL LEARNING SOFTWARE THAT DELIVERS AND MANAGES TEACHING, COURSE CONTENT, ASSESSMENT, COMMUNICATIONS, ORDERING, ASSET MANAGEMENT, DOCUMENT RETENTION AND MANAGEMENT AND REPORTING; TECHNOLOGY CUSTOMER SUPPORT SERVICES TO STUDENTS AND FAMILIES VIA PHONE, EMAIL AND ONLINE, NAMELY, TROUBLESHOOTING IN THE NATURE OF DIAGNOSING COMPUTER HARDWARE AND SOFTWARE PROBLEMS AND TROUBLESHOOTING OF COMPUTER SOFTWARE PROBLEMS (U.S. CLS. 100 AND 101).

FIRST USE 2-17-2011; IN COMMERCE 2-17-2011.

4,119,532. LECOMPTE, HAP, ROSSMOOR, CA. SN 85-236,537. PUB. 6-14-2011, FILED 2-8-2011.

**CLICK OR CALL WE BRAND IT
ALL**

THE MARK CONSISTS OF STANDARD CHARACTERS WITHOUT CLAIM TO ANY PARTICULAR FONT, STYLE, SIZE, OR COLOR.

CLASS 35—ADVERTISING AND BUSINESS

FOR ADVERTISING SERVICES, NAMELY, CREATING CORPORATE LOGOS FOR OTHERS; ADVERTISING, MARKETING AND PROMOTION SERVICES (U.S. CLS. 100, 101 AND 102).

FIRST USE 8-24-2010; IN COMMERCE 10-16-2011.

CLASS 42—SCIENTIFIC AND COMPUTER SERVICES

FOR GRAPHIC DESIGN SERVICES; WEBSITE DESIGN AND DEVELOPMENT FOR OTHERS (U.S. CLS. 100 AND 101).

FIRST USE 8-24-2010; IN COMMERCE 10-16-2011.

4,119,540. FARMERS GROUP, INC., LOS ANGELES, CA. SN 85-239,829. PUB. 5-17-2011, FILED 2-11-2011.

FARMERS INSURANCE OPEN

THE MARK CONSISTS OF STANDARD CHARACTERS WITHOUT CLAIM TO ANY PARTICULAR FONT, STYLE, SIZE, OR COLOR.

OWNER OF U.S. REG. NOS. 953,862, 1,920,139, AND OTHERS.

NO CLAIM IS MADE TO THE EXCLUSIVE RIGHT TO USE "OPEN" AS TO THE SERVICES LISTED IN CLASS 41, APART FROM THE MARK AS SHOWN.

CLASS 18—LEATHER GOODS

FOR GOLF UMBRELLAS (U.S. CLS. 1, 2, 3, 22 AND 41). FIRST USE 6-0-2010; IN COMMERCE 6-0-2010.

CLASS 25—CLOTHING

FOR CLOTHING, NAMELY, T-SHIRTS, POLO SHIRTS, SHORT SLEEVED SHIRTS, LONG SLEEVED SHIRTS, GOLF SHIRTS, GLOVES, VEST, SWEATERS, JACKETS, WIND JACKETS, RAIN JACKETS, VISORS, GOLF HATS, AND CAPS (U.S. CLS. 22 AND 39).

FIRST USE 6-0-2010; IN COMMERCE 6-0-2010.

CLASS 28—TOYS AND SPORTING GOODS

FOR GOLF BALLS, GOLF BAGS, PIN FLAGS (U.S. CLS. 22, 23, 38 AND 50).

FIRST USE 6-0-2010; IN COMMERCE 6-0-2010.

CLASS 41—EDUCATION AND ENTERTAINMENT

FOR ENTERTAINMENT IN THE NATURE OF A GOLF EVENT (U.S. CLS. 100, 101 AND 107).

FIRST USE 1-23-2010; IN COMMERCE 1-28-2010.

4,119,565. SHOUT MOUNTAIN, CRANBERRY TWP, PA. SN 85-253,977. PUB. 7-26-2011, FILED 2-28-2011.



THE MARK CONSISTS OF AN OUTLINE OF A MOUNTAIN PEAK, A HUMAN SILHOUETTE OF A MAN WITH ARMS OUTSTRETCHED ON THE PEAK OF THE MOUNTAIN, AND STYLIZED LETTERS THAT SPELL OUT "SHOUT MOUNTAIN".

CLASS 35—ADVERTISING AND BUSINESS

FOR PROMOTING, ADVERTISING AND MARKETING OF THE BRANDS, PRODUCTS, SERVICES OR ONLINE WEBSITES OF INDIVIDUALS, BUSINESSES AND NONPROFIT ORGANIZATIONS (U.S. CLS. 100, 101 AND 102).

FIRST USE 2-15-2011; IN COMMERCE 2-15-2011.

CLASS 41—EDUCATION AND ENTERTAINMENT

FOR ENTERTAINMENT SERVICES, NAMELY, PROVIDING A WEB SITE FEATURING PHOTOGRAPHIC, AUDIO, VIDEO AND PROSE PRESENTATIONS FEATURING RELIGIOUS INSTRUCTION (U.S. CLS. 100, 101 AND 107).

FIRST USE 2-15-2011; IN COMMERCE 2-15-2011.

CLASS 42—SCIENTIFIC AND COMPUTER SERVICES

FOR COMPUTER SERVICES, NAMELY, CREATING AN ON-LINE COMMUNITY FOR REGISTERED USERS TO PARTICIPATE IN DISCUSSIONS, GET FEEDBACK FROM THEIR PEERS, FORM VIRTUAL COMMUNITIES, AND ENGAGE IN SOCIAL NETWORKING (U.S. CLS. 100 AND 101).

FIRST USE 2-15-2011; IN COMMERCE 2-15-2011.

4,119,570. GEORGE & COMPANY, LLC, NAPLES, FL. SN 85-256,794. PUB. 10-11-2011, FILED 3-3-2011.



OWNER OF U.S. REG. NOS. 2,802,321, 3,854,443, AND OTHERS.

THE MARK CONSISTS OF THE LETTERS "L", "C" AND "R" SHOWN IN A ROLLING DICE CONFIGURATION.

CLASS 9—ELECTRICAL AND SCIENTIFIC APPARATUS

FOR ELECTRONIC GAME PROGRAMS; DOWNLOADABLE ELECTRONIC GAMES VIA THE INTERNET AND WIRELESS DEVICES; ELECTRONIC GAME SOFTWARE FOR HANDHELD ELECTRONIC DEVICES; ELECTRONIC GAMES SOFTWARE FOR CELLULAR TELEPHONES; ELECTRONIC GAME SOFTWARE FOR WIRELESS DEVICES; COMPUTER GAME DISCS; COMPUTER PROGRAMS FOR PRE-RECORDED GAMES; COMPUTER GAME SOFTWARE; VIDEO GAME SOFTWARE; GAME SOFTWARE; ELECTRONIC GAMES SOFTWARE (U.S. CLS. 21, 23, 26, 36 AND 38).

FIRST USE 10-1-2010; IN COMMERCE 10-1-2010.

CLASS 41—EDUCATION AND ENTERTAINMENT

FOR PROVIDING TEMPORARY USE OF NON-DOWNLOADABLE ELECTRONIC GAMES VIA THE INTERNET AND WIRELESS DEVICES; PROVIDING TEMPORARY USE OF NON-DOWNLOADABLE ELECTRONIC GAME SOFTWARE FOR PLAYING ONLINE ON WIRELESS DEVICES; PROVIDING TEMPORARY USE OF ONLINE NON-DOWNLOADABLE COMPUTER GAME PROGRAMS; PROVIDING TEMPORARY USE OF NON-DOWNLOADABLE COMPUTER PROGRAMS FOR PLAYING PRE-RECORDED GAMES ONLINE; ENTERTAINMENT SERVICES, NAMELY, PROVIDING ONLINE COMPUTER GAMES; PROVIDING INFORMATION ON-LINE RELATING TO COMPUTER GAMES AND COMPUTER ENHANCEMENTS FOR GAMES; PROVIDING A COMPUTER GAME FOR USE NETWORK-WIDE BY NETWORK USERS; ORGANIZING COMPUTER AND VIDEO GAME COMPETITIONS; PROVIDING ON-LINE COMPUTER AND VIDEO GAMES; ENTERTAINMENT INFORMATION SERVICES, NAMELY, PROVIDING ON-LINE INFORMATION WITH REGARD TO GAMES THROUGH WORLD WIDE WEB AND MOBILE PHONES; PROVIDING ONLINE COMPUTER GAMES; ENTERTAINMENT SERVICES, NAMELY, PROVIDING VIDEO GAMES FOR PLAY ONLINE, OR ONLINE ON WIRELESS DEVICES (U.S. CLS. 100, 101 AND 107).

FIRST USE 5-0-2011; IN COMMERCE 5-0-2011.

4,119,578. LEACHCO, INC., ADA, OK. SN 85-259,740. PUB. 6-21-2011, FILED 3-7-2011.

PREGGIE POUFFE

THE MARK CONSISTS OF STANDARD CHARACTERS WITHOUT CLAIM TO ANY PARTICULAR FONT, STYLE, SIZE, OR COLOR.

OWNER OF U.S. REG. NO. 3,277,798.
NO CLAIM IS MADE TO THE EXCLUSIVE RIGHT TO USE "POUFFE", APART FROM THE MARK AS SHOWN.

CLASS 10—MEDICAL APPARATUS

FOR PILLOWS FOR THERAPEUTIC PURPOSES (U.S. CLS. 26, 39 AND 44).
FIRST USE 11-15-2011; IN COMMERCE 11-15-2011.

CLASS 20—FURNITURE AND ARTICLES NOT OTHERWISE CLASSIFIED

FOR PILLOWS (U.S. CLS. 2, 13, 22, 25, 32 AND 50).
FIRST USE 11-15-2011; IN COMMERCE 11-15-2011.

4,119,585. COMSCORE, INC., RESTON, VA. SN 85-262,837.
PUB. 9-6-2011, FILED 3-9-2011.

DIGITAL ANALYTIX

THE MARK CONSISTS OF STANDARD CHARACTERS WITHOUT CLAIM TO ANY PARTICULAR FONT, STYLE, SIZE, OR COLOR.

NO CLAIM IS MADE TO THE EXCLUSIVE RIGHT TO USE "DIGITAL", APART FROM THE MARK AS SHOWN.

CLASS 35—ADVERTISING AND BUSINESS

FOR BUSINESS CONSULTING AND RESEARCH INFORMATION SERVICES, NAMELY, MONITORING, TRACKING, AND REPORTING OF THE USE OF DIGITAL MEDIA (U.S. CLS. 100, 101 AND 102).
FIRST USE 2-1-2011; IN COMMERCE 3-14-2011.

CLASS 42—SCIENTIFIC AND COMPUTER SERVICES

FOR COMPUTER SERVICES, NAMELY, CONSULTATION SERVICES RELATED TO WEB SITES; COMPUTER AND WEBSITE DIAGNOSTIC SERVICES; TRACKING, ANALYZING, EVALUATING AND ADVISING OTHERS REGARDING WEBSITE DESIGN, IMPLEMENTATION, USABILITY, FUNCTIONING, PERFORMANCE, AND OPTIMIZATION; COMPUTER SERVICES, NAMELY, MONITORING AND REPORTING ON THE PERFORMANCE, AVAILABILITY, AND ERRORS OF WEB SITES OF OTHERS; MANAGING AND OPTIMIZING WEBSITE PERFORMANCE; TECHNICAL SUPPORT, NAMELY, MONITORING NETWORK SYSTEM (U.S. CLS. 100 AND 101).
FIRST USE 2-1-2011; IN COMMERCE 3-14-2011.

4,119,604. VOX MEDIA, INC., WASHINGTON, DC. SN 85-273,149. PUB. 10-25-2011, FILED 3-22-2011.

BASEBALL NATION

THE MARK CONSISTS OF STANDARD CHARACTERS WITHOUT CLAIM TO ANY PARTICULAR FONT, STYLE,

SIZE, OR COLOR.

NO CLAIM IS MADE TO THE EXCLUSIVE RIGHT TO USE "BASEBALL", APART FROM THE MARK AS SHOWN.

CLASS 38—COMMUNICATION

FOR PROVIDING ON-LINE ELECTRONIC BULLETIN BOARDS FOR TRANSMISSION OF MESSAGES AND INFORMATION AMONG USERS IN THE FIELD OF SPORTS (U.S. CLS. 100, 101 AND 104).
FIRST USE 2-28-2011; IN COMMERCE 2-28-2011.

CLASS 41—EDUCATION AND ENTERTAINMENT

FOR ONLINE JOURNALS, NAMELY, BLOGS, IN THE FIELD OF SPORTS; PROVIDING A WIDE RANGE OF INFORMATION IN THE FIELDS OF SPORTS; PROVIDING INFORMATION VIA COMPUTER AND DIGITAL NETWORKS IN THE FIELD OF SPORTS; PROVIDING A WEBSITE FEATURING INFORMATION RELATED TO THE SPORT OF BASEBALL; EDUCATION AND ENTERTAINMENT SERVICES, NAMELY, PROVIDING NETWORK OF WEBSITES FEATURING INFORMATION, DATA, OPINIONS, COMMENTS AND IMAGES ON THE SPORT OF BASEBALL (U.S. CLS. 100, 101 AND 107).
FIRST USE 2-28-2011; IN COMMERCE 2-28-2011.

4,119,620. USABLE MUTUAL INSURANCE COMPANY, LITTLE ROCK, AR. SN 85-286,120. PUB. 8-16-2011, FILED 4-5-2011.

CatchAir Youth Asthma Program

THE MARK CONSISTS OF STANDARD CHARACTERS WITHOUT CLAIM TO ANY PARTICULAR FONT, STYLE, SIZE, OR COLOR.

NO CLAIM IS MADE TO THE EXCLUSIVE RIGHT TO USE "YOUTH ASTHMA PROGRAM", APART FROM THE MARK AS SHOWN.

CLASS 41—EDUCATION AND ENTERTAINMENT

FOR PROVIDING INFORMATION IN THE FIELD OF HEALTH EDUCATION (U.S. CLS. 100, 101 AND 107).
FIRST USE 5-1-2011; IN COMMERCE 5-1-2011.

CLASS 44—MEDICAL, BEAUTY AND AGRICULTURAL SERVICES

FOR PROVIDING HEALTH INFORMATION RELATING TO MEDICAL PROBLEMS AND CONDITIONS (U.S. CLS. 100 AND 101).
FIRST USE 5-1-2011; IN COMMERCE 5-1-2011.

4,119,639. GLOBAL MARINE PHYTOPLANKTON COMPANY, LLC, RENO, NV. SN 85-295,277. PUB. 8-30-2011, FILED 4-14-2011.

REJUVASEA

THE MARK CONSISTS OF STANDARD CHARACTERS WITHOUT CLAIM TO ANY PARTICULAR FONT, STYLE, SIZE, OR COLOR.

CLASS 3—COSMETICS AND CLEANING PREPARATIONS

FOR ANTI-AGING CREAM, ANTI-WRINKLE CREAM, SKIN EXFOLIANT LOTION, SKIN CLEANSER, NON-MEDICATED SKIN CREAM, HAIR SHAMPOO, HAIR CONDITIONER, BATHING LOTION, BEAUTY LOTION, BODY AND HAND LOTION (U.S. CLS. 1, 4, 6, 50, 51 AND 52).

FIRST USE 11-0-2011; IN COMMERCE 11-0-2011.

CLASS 5—PHARMACEUTICALS

FOR DIETARY SUPPLEMENTS (U.S. CLS. 6, 18, 44, 46, 51 AND 52).

FIRST USE 11-0-2011; IN COMMERCE 11-0-2011.

4,119,640. 3 LEGGED THING LIMITED, STAGSDEN, UNITED KINGDOM. SN 85-295,907. PUB. 10-11-2011, FILED 4-15-2011.

3 LEGGED THING

OWNER OF UNITED KINGDOM REG. NO. 2553106, DATED 7-15-2010, EXPIRES 7-15-2020.

THE MARK CONSISTS OF THE STYLIZED WORDING AND NUMBER "3 LEGGED THING".

CLASS 9—ELECTRICAL AND SCIENTIFIC APPARATUS

FOR (BASED ON 44(E)) BAGS FOR CAMERAS AND PHOTOGRAPHIC EQUIPMENT; CAMERA CASES; CAMERA CLOSURES; CAMERA MOUNTS AND SUPPORTS; CAMERA STABILITY ACCESSORY, NAMELY, A SUPPORT ARM, VEST AND SLED FOR FILM AND VIDEO CAMERAS TO ABSORB SHAKING MOVES WHILE SHOOTING; CAMERA TRIPODS; CARRYING CASES FOR ELECTRONIC EQUIPMENT, NAMELY, VIDEO, FILM AND DIGITAL CAMERA EQUIPMENT, ACCESSORIES AND RELATED GOODS; CASES FOR PHOTOGRAPHIC APPARATUS; COLLAPSIBLE LIGHT DIRECTORS AND DIFFUSERS FOR USE WITH PHOTOGRAPHIC LIGHTING EQUIPMENT FOR PROFESSIONAL AND HIGH-END PHOTOGRAPHY; DIGITAL CAMERA ACCESSORY IN THE NATURE OF A DIGITAL PHOTO VIEWER; LIGHT DIRECTORS AND PHOTOGRAPHIC LIGHTING TENTS, ALL FOR USE WITH PHOTOGRAPHIC LIGHTING EQUIPMENT FOR PROFESSIONAL AND HIGH-END PHOTOGRAPHY; MONOPODS FOR CAMERAS; MOUNTING DEVICES FOR CAMERAS AND MONITORS; PORTABLE PHOTOGRAPHY EQUIPMENT, NAMELY, REFLECTORS, TRIPODS, LIGHT STANDS AND SUPPORTS AND BAGS SPECIALLY ADAPTED FOR THESE GOODS; TILTING HEADS; TRIPODS; TRIPODS FOR CAMERAS (U.S. CLS. 21, 23, 26, 36 AND 38).

CLASS 25—CLOTHING

FOR (BASED ON USE IN COMMERCE) BOTTOMS; BUTTON DOWN SHIRTS; EYESHADES; GLOVES AS CLOTHING; HOODED SWEAT SHIRTS; HOODS; JACKETS; JERSEYS; POLO SHIRTS; SHIRTS; SHIRTS FOR INFANTS, BABIES, TODDLERS AND CHILDREN; SHORT-SLEEVED OR LONG-SLEEVED T-SHIRTS; SHORT-SLEEVED SHIRTS; SWEAT SHIRTS; T-SHIRTS; T-SHIRTS FOR MEN, WOMEN AND CHILDREN; TEE SHIRTS; TOPS; TRAVEL CLOTHING CONTAINED IN A PACKAGE COMPRISING REVERSIBLE JACKETS, PANTS, SKIRTS, TOPS AND A BELT OR SCARF; WEARABLE GARMENTS AND CLOTHING, NAMELY, SHIRTS; WOMEN'S CLOTHING, NAMELY, SHIRTS, DRESSES, SKIRTS, BLOUSES; BASEBALL CAPS AND HATS; HATS; HATS FOR INFANTS, BABIES, TODDLERS AND CHILDREN; SPORTS CAPS AND HATS; WOMEN'S HATS AND HOODS; WOOLLY HATS (U.S. CLS. 22 AND 39).

FIRST USE 7-12-2010; IN COMMERCE 7-12-2010.

4,119,642. FOODHANDLER, INC., RENO, NV. SN 85-298,222. PUB. 8-30-2011, FILED 4-18-2011.

TOUCHING IS BELIEVING

THE MARK CONSISTS OF STANDARD CHARACTERS WITHOUT CLAIM TO ANY PARTICULAR FONT, STYLE, SIZE, OR COLOR.

CLASS 9—ELECTRICAL AND SCIENTIFIC APPARATUS

FOR PROTECTIVE GLOVES FOR INDUSTRIAL USE (U.S. CLS. 21, 23, 26, 36 AND 38).

FIRST USE 4-0-2011; IN COMMERCE 4-0-2011.

CLASS 10—MEDICAL APPARATUS

FOR PROTECTIVE DISPOSABLE GLOVES FOR MEDICAL AND DENTAL USE (U.S. CLS. 26, 39 AND 44).

FIRST USE 4-0-2011; IN COMMERCE 4-0-2011.

CLASS 21—HOUSEWARES AND GLASS

FOR DISPOSABLE SANITARY GLOVES FOR USE IN THE FOOD INDUSTRY (U.S. CLS. 2, 13, 23, 29, 30, 33, 40 AND 50).

FIRST USE 4-0-2011; IN COMMERCE 4-0-2011.

4,119,647. NGL ENERGY PARTNERS LP, TULSA, OK. SN 85-299,761. PUB. 10-25-2011, FILED 4-20-2011.



NO CLAIM IS MADE TO THE EXCLUSIVE RIGHT TO USE "ENERGY PARTNERS LP", APART FROM THE MARK AS SHOWN.

THE MARK CONSISTS OF THE LETTER "G" BETWEEN THE LETTERS "N" AND "L" WITH THE LETTER "G" HAVING LATITUDE AND LONGITUDE LINES, AND WITH "ENERGY PARTNERS LP" BENEATH THE "NGL".

CLASS 4—LUBRICANTS AND FUELS

FOR NATURAL GAS LIQUIDS, NAMELY, PROPANE, BUTANE, ISO BUTANE AND NATURAL GASOLINE (U.S. CLS. 1, 6 AND 15).

FIRST USE 11-0-2011; IN COMMERCE 11-0-2011.

CLASS 39—TRANSPORTATION AND STORAGE

FOR STORAGE, DISTRIBUTION AND TRANSPORTATION OF NATURAL GAS LIQUIDS, NAMELY, PROPANE, BUTANE, ISO BUTANE AND NATURAL GASOLINE (U.S. CLS. 100 AND 105).

FIRST USE 11-0-2011; IN COMMERCE 11-0-2011.

4,119,651. MARK ANTHONY INTERNATIONAL SRL, ST. MICHAEL, BARBADOS. SN 85-300,095. PUB. 9-6-2011, FILED 4-20-2011.

MIKE'S HARD WINTER BLACKBERRY

THE MARK CONSISTS OF STANDARD CHARACTERS WITHOUT CLAIM TO ANY PARTICULAR FONT, STYLE, SIZE, OR COLOR.

OWNER OF U.S. REG. NOS. 3,125,839, 3,295,391, AND OTHERS.

NO CLAIM IS MADE TO THE EXCLUSIVE RIGHT TO USE "HARD" OR "BLACKBERRY", APART FROM THE MARK AS SHOWN.

CLASS 32—LIGHT BEVERAGES

FOR FLAVORED BREWED MALT-BASED ALCOHOLIC BEVERAGES IN THE NATURE OF BEER (U.S. CLS. 45, 46 AND 48).

FIRST USE 9-22-2011; IN COMMERCE 9-22-2011.

CLASS 33—WINES AND SPIRITS

FOR ALCOHOLIC FLAVORED MALT COOLERS (U.S. CLS. 47 AND 49).

FIRST USE 9-22-2011; IN COMMERCE 9-22-2011.

4,119,657. COVERALL NORTH AMERICA, INC., BOCA RATON, FL. SN 85-307,610. PUB. 9-13-2011, FILED 4-28-2011.



THE COLOR(S) GREY, GREEN AND WHITE IS/ARE CLAIMED AS A FEATURE OF THE MARK.

THE MARK CONSISTS OF THE LETTERS "IAI". THE FIRST "I" IS DISPLAYED IN LOWER CASE AND THE COLOR GREY, THE CAPITALIZED LETTER "A" IS SHOWN IN THE COLOR GREEN AND THE SECOND LOWER CASE "I" IS DISPLAYED IN WHITE SUPERIMPOSED ON THE LETTER "A". TO THE RIGHT OF THE LETTERS ARE WORDS "INNOVATION ACCOUNTABILITY INTEGRITY" IN LOWER CASE LETTERING DISPLAYED IN THE COLOR GREY.

CLASS 35—ADVERTISING AND BUSINESS

FOR FRANCHISING, NAMELY, OFFERING BUSINESS MANAGEMENT ASSISTANCE IN THE ESTABLISHMENT AND/OR OPERATION OF BUSINESSES ENGAGED IN THE MAINTENANCE AND CLEANING OF OFFICES AND COMMERCIAL AND MEDICAL BUILDINGS (U.S. CLS. 100, 101 AND 102).

FIRST USE 6-30-2011; IN COMMERCE 6-30-2011.

CLASS 37—CONSTRUCTION AND REPAIR

FOR MAINTENANCE AND CLEANING OF OFFICES AND COMMERCIAL AND MEDICAL BUILDINGS (U.S. CLS. 100, 103 AND 106).

FIRST USE 9-13-2011; IN COMMERCE 9-13-2011.

4,119,667. HARTE-HANKS SHOPPERS, INC., DBA PENNY-SAVERUSA.COM, BREA, CA. SN 85-312,034. PUB. 9-13-2011, FILED 5-4-2011.

MOGASA

THE MARK CONSISTS OF STANDARD CHARACTERS WITHOUT CLAIM TO ANY PARTICULAR FONT, STYLE, SIZE, OR COLOR.

THE WORDING "MOGASA" HAS NO MEANING IN A FOREIGN LANGUAGE.

CLASS 9—ELECTRICAL AND SCIENTIFIC APPARATUS

FOR COMPUTER APPLICATION SOFTWARE FOR MOBILE PHONES, NAMELY, SOFTWARE FOR USE IN POSTING, SEARCHING, LOCATING, AND SHARING INFORMATION WITH OTHERS ABOUT GARAGE SALES (U.S. CLS. 21, 23, 26, 36 AND 38).

FIRST USE 7-6-2011; IN COMMERCE 7-6-2011.

CLASS 42—SCIENTIFIC AND COMPUTER SERVICES

FOR APPLICATION SERVICE PROVIDER (ASP) FEATURING SOFTWARE FOR USE WITH MOBILE DEVICES FOR USE IN POSTING, SEARCHING, LOCATING, AND SHARING INFORMATION WITH OTHERS ABOUT GARAGE SALES (U.S. CLS. 100 AND 101).
FIRST USE 7-6-2011; IN COMMERCE 7-6-2011.

4,119,680. GRANT, WINSTON J., MIAMI GARDENS, FL. SN 85-325,450. PUB. 10-11-2011, FILED 5-19-2011.

AUNT I'S

THE MARK CONSISTS OF STANDARD CHARACTERS WITHOUT CLAIM TO ANY PARTICULAR FONT, STYLE, SIZE, OR COLOR.

CLASS 30—STAPLE FOODS

FOR BARBEQUE SAUCE; EDIBLE SPICES; HOT SAUCE; SAUCES; SPICE BLENDS; SPICE RUBS; SPICES (U.S. CL. 46).
FIRST USE 11-1-2011; IN COMMERCE 12-1-2011.

CLASS 43—HOTEL AND RESTAURANT SERVICES

FOR CAFE AND RESTAURANT SERVICES; CAFE-RESTAURANTS; RESTAURANT; RESTAURANT AND CATERING SERVICES; RESTAURANT SERVICES, INCLUDING SIT-DOWN SERVICE OF FOOD AND TAKE-OUT RESTAURANT SERVICES; RESTAURANT SERVICES, NAMELY, PROVIDING OF FOOD AND BEVERAGES FOR CONSUMPTION ON AND OFF THE PREMISES (U.S. CLS. 100 AND 101).
FIRST USE 4-0-1987; IN COMMERCE 4-0-1987.

4,119,687. ISCA TECHNOLOGIES, INC., RIVERSIDE, CA. SN 85-326,595. PUB. 10-18-2011, FILED 5-20-2011.

SPLAT

THE MARK CONSISTS OF STANDARD CHARACTERS WITHOUT CLAIM TO ANY PARTICULAR FONT, STYLE, SIZE, OR COLOR.

CLASS 5—PHARMACEUTICALS

FOR INSECTICIDES; INSECT ATTRACTANTS, NAMELY, CHEMICAL COMPOSITIONS TO ATTRACT INSECTS FOR PEST CONTROL PURPOSES; INSECT REPELLANTS, NAMELY, CHEMICAL COMPOSITIONS TO REPEL INSECTS FOR PEST CONTROL PURPOSES; INSECT FEEDING SIMULANTS, NAMELY, CHEMICAL COMPOSITIONS TO INCREASE FEEDING BEHAVIORS OF INSECTS FOR PEST CONTROL PURPOSES (U.S. CLS. 6, 18, 44, 46, 51 AND 52).
FIRST USE 11-15-2004; IN COMMERCE 11-15-2004.

CLASS 21—HOUSEWARES AND GLASS

FOR INSECT TRAPS AND LURES (U.S. CLS. 2, 13, 23, 29, 30, 33, 40 AND 50).
FIRST USE 11-10-2006; IN COMMERCE 11-10-2006.

4,119,698. RELIANT ENERGY RETAIL HOLDINGS, LLC, HOUSTON, TX. SN 85-340,324. PUB. 10-11-2011, FILED 6-7-2011.

Reliant Innovation Avenue

THE MARK CONSISTS OF STANDARD CHARACTERS WITHOUT CLAIM TO ANY PARTICULAR FONT, STYLE, SIZE, OR COLOR.

NO CLAIM IS MADE TO THE EXCLUSIVE RIGHT TO USE "INNOVATION", APART FROM THE MARK AS SHOWN.

CLASS 35—ADVERTISING AND BUSINESS

FOR PROVIDING TECHNOLOGICAL INFORMATION ABOUT ENERGY EFFICIENCY (U.S. CLS. 100, 101 AND 102).
FIRST USE 10-1-2011; IN COMMERCE 10-1-2011.

CLASS 42—SCIENTIFIC AND COMPUTER SERVICES

FOR PROVIDING TECHNOLOGICAL INFORMATION ABOUT ENVIRONMENTALLY-FRIENDLY INNOVATIONS FOR HOME OWNERS (U.S. CLS. 100 AND 101).
FIRST USE 10-1-2011; IN COMMERCE 10-1-2011.

4,119,721. DOCUMENTARY ARTS, INC., DALLAS, TX. SN 85-976,123. PUB. 5-24-2011, FILED 12-17-2010.

CONNECTING CULTURES

THE MARK CONSISTS OF STANDARD CHARACTERS WITHOUT CLAIM TO ANY PARTICULAR FONT, STYLE, SIZE, OR COLOR.

NO CLAIM IS MADE TO THE EXCLUSIVE RIGHT TO USE "CULTURES", APART FROM THE MARK AS SHOWN.

CLASS 9—ELECTRICAL AND SCIENTIFIC APPARATUS

FOR AUDIO CASSETTE TAPES, COMPACT DISCS, CD-ROMS, DVDS, DVDROMS, VIDEO RECORDING, AND SOUND RECORDINGS FEATURING MUSIC AND DOCUMENTARY ABOUT THE CROSS-SECTION OF AMERICAN LIFE THROUGH THE CAREERS OF MUSICIANS AND THE TRADITIONS THEY REPRESENT; ENTERTAINMENT, EDUCATIONAL, AND DOCUMENTARY MOTION PICTURE FILMS AND FILMS FOR TELEVISION FEATURING MUSIC AND DOCUMENTARY ABOUT THE CROSS-SECTION OF AMERICAN LIFE THROUGH THE CAREERS OF MUSICIANS AND THE TRADITIONS THEY REPRESENT; MULTIMEDIA PRODUCTS SUCH AS CD-ROMS AND DVDS AND DVD-ROMS, AUDIO PROGRAMS AND INTERACTIVE MEDIA PROGRAMS FEATURING PHOTOGRAPHS, VIDEOS, MUSIC, DANCE, AND SPOKEN OR TEXTUAL INFORMATION; ELECTRONIC PUBLICATIONS, NAMELY, BOOKS FEATURING AMERICAN LIFE THROUGH THE CAREERS OF MUSICIANS AND THE TRADITIONS THEY REPRESENT RECORDED ON COMPUTER MEDIA (U.S. CLS. 21, 23, 26, 36 AND 38).

FIRST USE 12-31-2011; IN COMMERCE 12-31-2011.

4,119,726. RUTHLESS ENTERTAINMENT PTE LTD, SINGAPORE, SINGAPORE. SN 85-976,238. PUB. 5-3-2011, FILED 12-9-2010.

**CLASS 16—PAPER GOODS AND PRINTED MATTER**

FOR BOOKS IN THE FIELD OF MUSIC; CONTEMPORARY, ARCHIVAL, VINTAGE AND HISTORIC PHOTOGRAPHS; BOOKS CONTAINING EPHEMERA, TEXTUAL AND PHOTOGRAPHIC MATERIAL (U.S. CLS. 2, 5, 22, 23, 29, 37, 38 AND 50).

FIRST USE 12-31-2011; IN COMMERCE 12-31-2011.

THE COLOR(S) RED, WHITE AND GREEN IS/ARE CLAIMED AS A FEATURE OF THE MARK.

THE MARK CONSISTS OF THE LETTER "D" TO RESEMBLE A SPANISH GREEN OLIVE; THE "D" IS OLIVE GREEN AND IS ON A RED SQUARE BACKGROUND WITH ITS CORNERS ROUNDED AND CLIPPED; THE RED SQUARE BACKGROUND INCLUDES THE RED HOLE IN THE MIDDLE OF THE LETTER "D" TO RESEMBLE A PIMENTO PEPPER; AND THERE IS A WHITE CURVED LINE FROM LOWER LEFT CORNER TO UPPER RIGHT CORNER CREATING A SHADOW EFFECT, SO THAT THE RED BECOMES GRADUALLY LIGHTER AND THE GREEN BECOMES GRADUALLY LIGHTER.

CLASS 41—EDUCATION AND ENTERTAINMENT

FOR EDUCATIONAL AND ENTERTAINMENT SERVICES, NAMELY, ORGANIZING, EXHIBITING AND PROVIDING INFORMATION CONCERNING MUSIC AND DOCUMENTARY ABOUT THE CROSS-SECTION OF AMERICAN LIFE THROUGH THE CAREERS OF MUSICIANS AND THE TRADITIONS THEY REPRESENT; EDUCATIONAL PROGRAMS IN THE NATURE OF CULTURAL EXHIBITIONS, LECTURES, MUSEUM EXHIBITIONS, AND SCHOOL EXHIBITIONS ALL FEATURING THE CROSS-SECTION OF AMERICAN LIFE THROUGH THE CAREERS OF MUSICIANS AND THE TRADITIONS THEY REPRESENT; PRODUCTION SERVICES, NAMELY, PRODUCTION OF MOTION PICTURES AND VIDEOS ABOUT THE CROSS-SECTION OF AMERICAN LIFE THROUGH THE CAREERS OF MUSICIANS AND THE TRADITIONS THEY REPRESENT (U.S. CLS. 100, 101 AND 107).

FIRST USE 9-30-2011; IN COMMERCE 9-30-2011.

CLASS 9—ELECTRICAL AND SCIENTIFIC APPARATUS

FOR COMPUTER APPLICATION SOFTWARE FOR MOBILE PHONES, NAMELY, SOFTWARE FOR DISPLAYING AND SHARING A USER'S LOCATION; FINDING, LOCATING, AND INTERACTING WITH OTHER USERS AND PLACES; AND FINDING NEARBY BARS, CLUBS AND RESTAURANTS TO BUY A DRINK OR OFFER TO BUY OTHER USERS A DRINK; DOWNLOADABLE SOFTWARE IN THE NATURE OF A MOBILE APPLICATION FOR DISPLAYING AND SHARING A USER'S LOCATION, FINDING, LOCATING, AND INTERACTING WITH OTHER USERS AND PLACES; AND FINDING NEARBY BARS, CLUBS AND RESTAURANTS TO BUY A DRINK OR OFFER TO BUY OTHER USERS A DRINK (U.S. CLS. 21, 23, 26, 36 AND 38).

FIRST USE 7-1-2011; IN COMMERCE 7-1-2011.

CLASS 45—PERSONAL AND LEGAL SERVICES

FOR ON-LINE SOCIAL NETWORKING SERVICES (U.S. CLS. 100 AND 101).

FIRST USE 7-1-2011; IN COMMERCE 7-1-2011.

4,119,728. MUSCULAR DYSTROPHY ASSOCIATION, INC., TUCSON, AZ. SN 85-976,256. PUB. 6-14-2011, FILED 1-20-2011.

4,119,732. ALLSTATE INSURANCE COMPANY, NORTH-BROOK, IL. SN 85-976,262. PUB. 11-30-2010, FILED 6-23-2010.



OWNER OF U.S. REG. NOS. 1,678,809, 2,895,111, AND OTHERS.

NO CLAIM IS MADE TO THE EXCLUSIVE RIGHT TO USE "ASSOCIATION", APART FROM THE MARK AS SHOWN.

THE MARK CONSISTS OF THE LETTERS "MDA" TO THE LEFT OF THE WORDS "MUSCULAR DYSTROPHY ASSOCIATION" TYPED VERTICALLY SEPARATED BY A LINE WITH THE WORDS "FIGHTING MUSCLE DISEASE" UNDER THE LINE.

SEC. 2(F) AS TO "MUSCULAR DYSTROPHY ASSOCIATION".

CLASS 36—INSURANCE AND FINANCIAL

FOR CHARITABLE FUNDRAISING SERVICES (U.S. CLS. 100, 101 AND 102).
FIRST USE 1-15-2011; IN COMMERCE 1-15-2011.

CLASS 41—EDUCATION AND ENTERTAINMENT

FOR ENTERTAINMENT SERVICES, NAMELY, PROVIDING A TELEVISION PROGRAM IN A TELETHON FORMAT TO RAISE PUBLIC AWARENESS ABOUT AND TO RAISE CHARITABLE FUNDS FOR BASIC AND APPLIED RESEARCH INTO NEUROMUSCULAR DISORDERS AND FUNDING FOR SERVICES TO PERSONS AFFLICTED BY SUCH DISORDERS; EDUCATIONAL SERVICES IN THE NATURE OF SEMINARS, COURSES, LECTURES AND VOCATIONAL SERVICES IN THE FIELD OF NEUROMUSCULAR DISORDERS; OVERNIGHT AND SUMMER CAMP SERVICES (U.S. CLS. 100, 101 AND 107).
FIRST USE 2-28-2011; IN COMMERCE 2-28-2011.

CLASS 42—SCIENTIFIC AND COMPUTER SERVICES

FOR MEDICAL RESEARCH SERVICES; MEDICAL AND SCIENTIFIC RESEARCH, NAMELY, CONDUCTING CLINICAL TRIALS FOR THERAPIES AND DRUGS (U.S. CLS. 100 AND 101).
FIRST USE 1-15-2011; IN COMMERCE 1-15-2011.

CLASS 43—HOTEL AND RESTAURANT SERVICES

FOR OVERNIGHT AND SUMMER CAMP SERVICES (U.S. CLS. 100 AND 101).
FIRST USE 4-15-2011; IN COMMERCE 4-15-2011.

CLASS 44—MEDICAL, BEAUTY AND AGRICULTURAL SERVICES

FOR MEDICAL CLINICS; PHYSICAL THERAPY SERVICES; PSYCHOLOGICAL COUNSELING (U.S. CLS. 100 AND 101).
FIRST USE 1-15-2011; IN COMMERCE 1-15-2011.

GOOD HANDS

THE MARK CONSISTS OF STANDARD CHARACTERS WITHOUT CLAIM TO ANY PARTICULAR FONT, STYLE, SIZE, OR COLOR.

OWNER OF U.S. REG. NOS. 2,512,298, 3,797,223, AND OTHERS.

CLASS 37—CONSTRUCTION AND REPAIR

FOR PROVIDING EMERGENCY ROAD SIDE REPAIR SERVICE FOR MOTORISTS (U.S. CLS. 100, 103 AND 106).

FIRST USE 11-18-2010; IN COMMERCE 11-18-2010.

CLASS 39—TRANSPORTATION AND STORAGE

FOR EMERGENCY VEHICLE TOWING SERVICES FOR MOTORISTS (U.S. CLS. 100 AND 105).

FIRST USE 11-18-2010; IN COMMERCE 11-18-2010.

4,119,736. ZENIMAX MEDIA INC., ROCKVILLE, MD. SN 85-976,300. PUB. 6-28-2011, FILED 12-10-2010.



THE MARK CONSISTS OF A DRAGON.

CLASS 9—ELECTRICAL AND SCIENTIFIC APPARATUS

FOR COMPUTER GAME SOFTWARE FOR USE WITH COMPUTERS AND VIDEO GAME CONSOLES; DOWNLOADABLE COMPUTER GAME SOFTWARE OFFERED VIA THE INTERNET AND WIRELESS DEVICES; MOTION PICTURE FILMS FEATURING FANTASY (U.S. CLS. 21, 23, 26, 36 AND 38).

FIRST USE 11-11-2011; IN COMMERCE 11-11-2011.

CLASS 41—EDUCATION AND ENTERTAINMENT

FOR ENTERTAINMENT SERVICES, NAMELY, PROVIDING INFORMATION RELATING TO ELECTRONIC COMPUTER GAMES VIA THE INTERNET (U.S. CLS. 100, 101 AND 107).
FIRST USE 11-11-2011; IN COMMERCE 11-11-2011.

* * * * *

SECTION 2.— INTERNATIONAL CLASSIFICATION

The short titles associated below with the international class numbers are terms designed merely for quick identification and are not an official part of the international classification. The full names of international classes are given in section 6.1 of the trademark rules of practice.

The designation "U.S. Cl." appearing in this section refers to the U.S. class in effect prior to Sep. 1, 1973 rather than the international class which applies to applications filed on or after that date. For adoption of international classification see notice in the OFFICIAL GAZETTE of Jun. 26, 1973 (911 O.G. TM 210).

Application in one class

CLASS 1—CHEMICALS

4,118,799. LUMMUS TECHNOLOGY INC., BLOOMFIELD, NJ. SN 77-330,878. PUB. 7-7-2009, FILED 11-15-2007.



OWNER OF U.S. REG. NOS. 530,898 AND 924,846.
NO CLAIM IS MADE TO THE EXCLUSIVE RIGHT TO USE "TECHNOLOGY" AND "COMPANY", APART FROM THE MARK AS SHOWN.

THE MARK CONSISTS OF "L LUMMUS TECHNOLOGY A CB&I COMPANY" AND A GLOBE DEVICE.

FOR CHEMICALS AND CHEMICAL PRODUCTS FOR REFINING AND HYDROCARBON PROCESSING IN THE CHEMICAL, PETROCHEMICAL, PETROLEUM REFINING, METALLURGICAL, NUCLEAR, PLASTIC, AND COAL PROCESSING INDUSTRIES (U.S. CLS. 1, 5, 6, 10, 26 AND 46).

FIRST USE 11-17-2011; IN COMMERCE 11-17-2011.

4,118,806. SENMI EKISU CO., LTD., EHIME, JAPAN. SN 77-351,215. PUB. 10-28-2008, FILED 12-13-2007.

VALTYRON

THE MARK CONSISTS OF STANDARD CHARACTERS WITHOUT CLAIM TO ANY PARTICULAR FONT, STYLE, SIZE, OR COLOR.

FOR PEPTIDE EXTRACTED FROM SARDINES AND SOLD TO MANUFACTURERS FOR USE AS AN INGREDIENT IN SUPPLEMENTS AND/OR FOODS (U.S. CLS. 1, 5, 6, 10, 26 AND 46).

FIRST USE 12-28-2011; IN COMMERCE 12-28-2011.

CLASS 1—(Continued).

4,118,831. W. R. GRACE & CO.-CONN., COLUMBIA, MD. SN 77-465,387. PUB. 3-31-2009, FILED 5-5-2008.

ENRICH

THE MARK CONSISTS OF STANDARD CHARACTERS WITHOUT CLAIM TO ANY PARTICULAR FONT, STYLE, SIZE, OR COLOR.

FOR CHEMICALS FOR USE IN INDUSTRY, NAMELY, CATALYSTS FOR USE IN BIOFUEL PRODUCTION (U.S. CLS. 1, 5, 6, 10, 26 AND 46).

FIRST USE 7-11-2011; IN COMMERCE 7-11-2011.

4,118,857. AJINOMOTO CO., INC., CHUO-KU, TOKYO, JAPAN. SN 77-503,270. PUB. 11-11-2008, FILED 6-19-2008.

ADVANTAME

THE MARK CONSISTS OF STANDARD CHARACTERS WITHOUT CLAIM TO ANY PARTICULAR FONT, STYLE, SIZE, OR COLOR.

FOR CHEMICAL PREPARATIONS FOR USE IN MANUFACTURING FOOD; ARTIFICIAL SWEETENERS (U.S. CLS. 1, 5, 6, 10, 26 AND 46).

FIRST USE 5-31-2011; IN COMMERCE 5-31-2011.

CLASS 1—(Continued).

4,118,894. PROSEEDS MARKETING, INC., JEFFERSON, OR. SN 77-655,733. PUB. 6-9-2009, FILED 1-23-2009.

Eco Thaw

THE MARK CONSISTS OF STANDARD CHARACTERS WITHOUT CLAIM TO ANY PARTICULAR FONT, STYLE, SIZE, OR COLOR.

NO CLAIM IS MADE TO THE EXCLUSIVE RIGHT TO USE "THAW", APART FROM THE MARK AS SHOWN.

FOR ANTI-FREEZING AND DE-ICING PREPARATIONS (U.S. CLS. 1, 5, 6, 10, 26 AND 46).

FIRST USE 12-31-2010; IN COMMERCE 12-1-2011.

4,119,116. COSWAY (M) SDN. BHD. (COMPANY NO. 50118-A), 50200 KUALA LUMPUR, MALAYSIA. SN 85-045,597. PUB. 5-10-2011, FILED 5-21-2010.



THE MARK CONSISTS OF THE STYLIZED TERM "ECOMAX"

FOR CHEMICAL ADDITIVES FOR FUEL TREATMENT (U.S. CLS. 1, 5, 6, 10, 26 AND 46).

FIRST USE 7-8-2006; IN COMMERCE 9-0-2010.

4,119,255. LEE COUNTY BOARD OF COUNTY COMMISSIONERS, FORT MYERS, FL. SN 85-124,966. PUB. 5-17-2011, FILED 9-8-2010.

OrganicLee

THE MARK CONSISTS OF STANDARD CHARACTERS WITHOUT CLAIM TO ANY PARTICULAR FONT, STYLE, SIZE, OR COLOR.

FOR ORGANIC COMPOST (U.S. CLS. 1, 5, 6, 10, 26 AND 46).

FIRST USE 10-24-2011; IN COMMERCE 10-24-2011.

CLASS 1—(Continued).

4,119,285. RIDLEY BLOCK OPERATIONS, INC., MANKATO, MN. SN 85-146,339. PUB. 3-22-2011, FILED 10-6-2010.

BULLETPROOF

THE MARK CONSISTS OF STANDARD CHARACTERS WITHOUT CLAIM TO ANY PARTICULAR FONT, STYLE, SIZE, OR COLOR.

FOR CHEMICAL COMPOSITIONS FOR USE AS SILAGE ENHANCER, SILAGE PRESERVATIVE, SILAGE STABILIZER, OR FEED BUNK STABILIZER; CHEMICAL COMPOSITIONS FOR USE IN OR WITH FERMENTED FEEDS, CURED HAYS, OR PROCESSED FEED CONDITIONING AS A PRESERVATIVE OR STABILIZER (U.S. CLS. 1, 5, 6, 10, 26 AND 46).

FIRST USE 3-18-2011; IN COMMERCE 3-18-2011.

4,119,345. VALAGRO S.P.A., PIAZZANO DI ATESSA(CH), ITALY. SN 85-184,894. PUB. 5-24-2011, FILED 11-24-2010.



THE MARK CONSISTS OF THE WORD "GLIMO" IN STYLIZED LETTERING.

FOR AGRICULTURAL FERTILIZER AND MANURE (U.S. CLS. 1, 5, 6, 10, 26 AND 46).

FIRST USE 4-21-2011; IN COMMERCE 4-21-2011.

4,119,371. SEGETIS, INC., GOLDEN VALLEY, MN. SN 85-194,502. PUB. 4-19-2011, FILED 12-9-2010.

JAVELIN

THE MARK CONSISTS OF STANDARD CHARACTERS WITHOUT CLAIM TO ANY PARTICULAR FONT, STYLE, SIZE, OR COLOR.

FOR CHEMICAL FOR USE IN THE MANUFACTURE OF RUBBERS, PLASTICS, ADHESIVES, CLEANING SOLUTIONS, POLYURETHANES, POLYMERS, MONOMERS, POLYMER ADDITIVES, SURFACTANTS, ADHESIVES, PAINTS, PLASTICIZERS, AND COATINGS; CHEMICAL PREPARATIONS FOR SCIENTIFIC PURPOSES; CHEMICALS FOR USE IN INDUSTRY AND SCIENCE (U.S. CLS. 1, 5, 6, 10, 26 AND 46).

FIRST USE 4-1-2011; IN COMMERCE 4-18-2011.

CLASS 1—(Continued).

4,119,480. KINETIC TECHNOLOGIES, LLC, LEXINGTON, KY. SN 85-220,701. PUB. 6-7-2011, FILED 1-19-2011.

KINETI-CLEAR

THE MARK CONSISTS OF STANDARD CHARACTERS WITHOUT CLAIM TO ANY PARTICULAR FONT, STYLE, SIZE, OR COLOR.

FOR BACTERIAL ADDITIVE FOR CLEANING STOCK TANK WATER FOR LIVESTOCK AND HORSES (U.S. CLS. 1, 5, 6, 10, 26 AND 46).

FIRST USE 2-7-2011; IN COMMERCE 2-7-2011.

4,119,498. KOLB CLEANING TECHNOLOGY GMBH, WILL-ICH, FED REP GERMANY. SN 85-224,732. PUB. 11-1-2011, FILED 1-24-2011.

MULTIEX

THE MARK CONSISTS OF STANDARD CHARACTERS WITHOUT CLAIM TO ANY PARTICULAR FONT, STYLE, SIZE, OR COLOR.

FOR DETERGENTS FOR INDUSTRIAL USE (U.S. CLS. 1, 5, 6, 10, 26 AND 46).

FIRST USE 2-10-2011; IN COMMERCE 6-16-2011.

4,119,501. GREEN ACRES INTERNATIONAL LLC, MERCER ISLAND, WA. SN 85-225,287. PUB. 5-31-2011, FILED 1-25-2011.

AGRIPOWER

THE MARK CONSISTS OF STANDARD CHARACTERS WITHOUT CLAIM TO ANY PARTICULAR FONT, STYLE, SIZE, OR COLOR.

FOR SOIL SUPPLEMENTS IN THE NATURE OF AN ALL NATURAL LIQUID FERTILIZER FOR DOMESTIC USE AND FOR AGRICULTURAL CROP GROWTH (U.S. CLS. 1, 5, 6, 10, 26 AND 46).

FIRST USE 2-1-2011; IN COMMERCE 2-1-2011.

CLASS 1—(Continued).

4,119,506. CABOT CORPORATION, BOSTON, MA. SN 85-226,007. PUB. 5-31-2011, FILED 1-25-2011.

ENOVA

THE MARK CONSISTS OF STANDARD CHARACTERS WITHOUT CLAIM TO ANY PARTICULAR FONT, STYLE, SIZE, OR COLOR.

FOR CHEMICALS USED IN INDUSTRY, NAMELY, AEROGELS (U.S. CLS. 1, 5, 6, 10, 26 AND 46).

FIRST USE 3-28-2011; IN COMMERCE 3-28-2011.

4,119,528. OCEAN ORGANICS, INC., ANN ARBOR, MI. SN 85-234,366. PUB. 6-14-2011, FILED 2-4-2011.

EFFICIENSEA

THE MARK CONSISTS OF STANDARD CHARACTERS WITHOUT CLAIM TO ANY PARTICULAR FONT, STYLE, SIZE, OR COLOR.

OWNER OF U.S. REG. NO. 3,703,662.

FOR FERTILIZERS AND PLANT NUTRIENTS; NUTRITIVE ADDITIVE TO ENHANCE THE BIOLOGICAL ACTIVITY OF SOIL, SEEDS AND PLANTS FOR PURPOSES OF FERTILIZATION; SOIL ADDITIVES; SOIL AMENDMENTS; SOIL IMPROVING AGENTS (U.S. CLS. 1, 5, 6, 10, 26 AND 46).

FIRST USE 3-0-2011; IN COMMERCE 3-0-2011.

CLASS 2—PAINTS

4,119,146. MICROJET TECHNOLOGY CO., LTD, HSINCHU, TAIWAN. SN 85-058,403. PUB. 5-31-2011, FILED 6-9-2010.

CurieJet

THE MARK CONSISTS OF STANDARD CHARACTERS WITHOUT CLAIM TO ANY PARTICULAR FONT, STYLE, SIZE, OR COLOR.

FOR PRINTING COMPOSITIONS, NAMELY, INKS, PRINTING INKS, GRAPHIC INKS, PAINTS AND DYES FOR USE ON MEDIA SUCH AS PAPERS, CIRCUIT BOARDS, DISPLAYS, GLASSES, CERAMICS, AND TEXTILES; INK AND COLOURED MEDIA IN STORAGE CONTAINERS FOR USE IN PRINTING; INK JET PRINTER CARTRIDGES FILLED (U.S. CLS. 6, 11 AND 16).

FIRST USE 12-21-2011; IN COMMERCE 12-21-2011.

CLASS 2—(Continued).

4,119,148. NANOSONIC, INC., PEMBROKE, VA. SN 85-059,205. PUB. 11-30-2010, FILED 6-10-2010.

HYBRIDSIL

THE MARK CONSISTS OF STANDARD CHARACTERS WITHOUT CLAIM TO ANY PARTICULAR FONT, STYLE, SIZE, OR COLOR.

FOR ARCHITECTURAL PROTECTIVE COATINGS FOR STRUCTURES (U.S. CLS. 6, 11 AND 16).
FIRST USE 6-0-2010; IN COMMERCE 6-0-2010.

4,119,232. HOME SHIELD, LLC, CROMWELL, CT. SN 85-108,624. PUB. 5-10-2011, FILED 8-16-2010.

Gorilla Coat

THE MARK CONSISTS OF STANDARD CHARACTERS WITHOUT CLAIM TO ANY PARTICULAR FONT, STYLE, SIZE, OR COLOR.

NO CLAIM IS MADE TO THE EXCLUSIVE RIGHT TO USE "COAT", APART FROM THE MARK AS SHOWN.

FOR LIQUID VINYL COATING FOR COMMERCIAL, INDUSTRIAL AND RESIDENTIAL EXTERIORS (U.S. CLS. 6, 11 AND 16).

FIRST USE 5-1-2011; IN COMMERCE 5-1-2011.

4,119,284. DYSTAR COLOURS DISTRIBUTION GMBH, 65926 FRANKFURT, FED REP GERMANY. SN 85-146,335. PUB. 5-17-2011, FILED 10-6-2010.

PALANIL

THE MARK CONSISTS OF STANDARD CHARACTERS WITHOUT CLAIM TO ANY PARTICULAR FONT, STYLE, SIZE, OR COLOR.

FOR DYES AND COLORANTS FOR USE IN THE MANUFACTURE OF TEXTILES (U.S. CLS. 6, 11 AND 16).

FIRST USE 9-29-1950; IN COMMERCE 7-9-1958.

CLASS 2—(Continued).

4,119,318. ROCHESTER ART SUPPLY INC, DBA ENKAUSTIKOS WAX ART SUPPLIES, ROCHESTER, NY. SN 85-172,163. PUB. 4-19-2011, FILED 11-9-2010.

Wax Snaps

THE MARK CONSISTS OF STANDARD CHARACTERS WITHOUT CLAIM TO ANY PARTICULAR FONT, STYLE, SIZE, OR COLOR.

NO CLAIM IS MADE TO THE EXCLUSIVE RIGHT TO USE "WAX", APART FROM THE MARK AS SHOWN.

FOR CLEAR AND PIGMENTED COATINGS USED IN THE NATURE OF PAINT; COATINGS FOR WOOD AS PAINTS; MIXED PAINTS; PAINT FOR ARTISTS; PAINTING SETS FOR ARTISTS; PAINTS; PAINTS FOR ARTS AND CRAFTS (U.S. CLS. 6, 11 AND 16).

FIRST USE 10-1-2011; IN COMMERCE 1-1-2012.

4,119,364. VERMONT PHOTOINKJET, LLC, TOPSHAM, VT. SN 85-191,398. PUB. 6-7-2011, FILED 12-6-2010.

INK THRIFT

THE MARK CONSISTS OF STANDARD CHARACTERS WITHOUT CLAIM TO ANY PARTICULAR FONT, STYLE, SIZE, OR COLOR.

NO CLAIM IS MADE TO THE EXCLUSIVE RIGHT TO USE "INK", APART FROM THE MARK AS SHOWN.

FOR INK JET CARTRIDGES; INK JET PRINTER INK (U.S. CLS. 6, 11 AND 16).

FIRST USE 1-26-2011; IN COMMERCE 1-26-2011.

4,119,622. HEARTHWARE, INC., LIBERTYVILLE, IL. SN 85-287,721. PUB. 7-12-2011, FILED 4-6-2011.

DURALON

THE MARK CONSISTS OF STANDARD CHARACTERS WITHOUT CLAIM TO ANY PARTICULAR FONT, STYLE, SIZE, OR COLOR.

FOR NONSTICK COATINGS FOR COOKWARE AND BAKEWARE (U.S. CLS. 6, 11 AND 16).

FIRST USE 8-6-2011; IN COMMERCE 8-6-2011.

CLASS 2—(Continued).

4,119,684. CHEMSPEC USA, INC., ORRVILLE, OH. SN 85-326,216. PUB. 10-11-2011, FILED 5-20-2011.

METACRYL

THE MARK CONSISTS OF STANDARD CHARACTERS WITHOUT CLAIM TO ANY PARTICULAR FONT, STYLE, SIZE, OR COLOR.

FOR CLEAR AND PIGMENTED COATINGS USED IN THE NATURE OF PAINT (U.S. CLS. 6, 11 AND 16).

FIRST USE 6-30-2011; IN COMMERCE 6-30-2011.

CLASS 3—COSMETICS AND CLEANING PREPARATIONS

4,118,771. COSMETIC CHANGES, LLC, AVENTURA, FL. SN 76-705,941. PUB. 5-10-2011, FILED 1-7-2011.

SMILE THERAPY

THE MARK CONSISTS OF STANDARD CHARACTERS WITHOUT CLAIM TO ANY PARTICULAR FONT, STYLE, SIZE, OR COLOR.

NO CLAIM IS MADE TO THE EXCLUSIVE RIGHT TO USE "THERAPY", APART FROM THE MARK AS SHOWN.

FOR TOPICAL SKIN CARE PREPARATIONS, NAMELY, ANTI-AGING CREAMS AND LOTIONS (U.S. CLS. 1, 4, 6, 50, 51 AND 52).

FIRST USE 12-15-2011; IN COMMERCE 12-15-2011.

4,118,869. MLA MULTIBRAND HOLDINGS, INC., VERNON, CA. SN 77-553,857. PUB. 1-13-2009, FILED 8-22-2008.

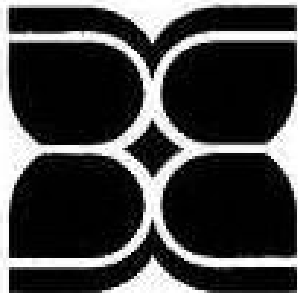

OWNER OF U.S. REG. NO. 3,504,130.

CLASS 3—(Continued).

THE MARK CONSISTS OF FOUR FLOWER PETALS OR LEAVES SURROUNDING A DIAMOND SHAPE.

FOR TOILETRIES, NAMELY, PERFUMES, COLOGNES AND EAUX DE TOILETTE, SCENTED BODY SPRAY, BODY LOTIONS, SKIN MOISTURIZERS, BODY CREAM, NAIL POLISH (U.S. CLS. 1, 4, 6, 50, 51 AND 52).

FIRST USE 10-0-2009; IN COMMERCE 10-0-2009.

4,118,875. TUPPERWARE PRODUCTS S.A., FRIBOURG, SWITZERLAND. SN 77-590,364. PUB. 3-3-2009, FILED 10-10-2008.

BANO DE BRILLO

THE MARK CONSISTS OF STANDARD CHARACTERS WITHOUT CLAIM TO ANY PARTICULAR FONT, STYLE, SIZE, OR COLOR.

THE FOREIGN WORDING IN THE MARK TRANSLATES INTO ENGLISH AS "GLOW BATH".

FOR HAIR CARE PREPARATIONS, NAMELY, CONDITIONERS AND LOTIONS (U.S. CLS. 1, 4, 6, 50, 51 AND 52).

FIRST USE 1-12-2012; IN COMMERCE 1-12-2012.

4,118,892. MIX BRANDS LLC, WILTON, CT. SN 77-646,818. PUB. 11-24-2009, FILED 1-9-2009.

LULU'S TIME BOMB

THE MARK CONSISTS OF STANDARD CHARACTERS WITHOUT CLAIM TO ANY PARTICULAR FONT, STYLE, SIZE, OR COLOR.

THE NAME "LULU" IDENTIFIES A LIVING INDIVIDUAL WHOSE CONSENT IS OF RECORD.

FOR NON-MEDICATED SKIN CARE PREPARATIONS; COSMETIC CREAMS FOR SKIN CARE (U.S. CLS. 1, 4, 6, 50, 51 AND 52).

FIRST USE 6-19-2007; IN COMMERCE 11-17-2011.

CLASS 3—(Continued).

4,118,942. GINGERLILY COSMETICS LIMITED, NOTTINGHAM, UNITED KINGDOM. SN 77-822,436. PUB. 6-1-2010, FILED 9-9-2009.

FRONTCOVER

THE MARK CONSISTS OF STANDARD CHARACTERS WITHOUT CLAIM TO ANY PARTICULAR FONT, STYLE, SIZE, OR COLOR.

FOR COSMETICS; COSMETIC KITS COMPRISING EYESHADOWS, GLITTER EYESHADOWS, MASCARA, EYE PENCILS, FALSE EYELASHES, MAKE-UP APPLICATORS AND BRUSHES, COSMETIC PENCILS AND EYEBROW PENCILS (U.S. CLS. 1, 4, 6, 50, 51 AND 52).

FIRST USE 12-0-2011; IN COMMERCE 12-0-2011.

4,119,122. L'OREAL USA CREATIVE, INC., NEW YORK, NY. SN 85-048,235. PUB. 8-3-2010, FILED 5-26-2010.

RADIANCE AMPLIFIER

THE MARK CONSISTS OF STANDARD CHARACTERS WITHOUT CLAIM TO ANY PARTICULAR FONT, STYLE, SIZE, OR COLOR.

OWNER OF U.S. REG. NOS. 1,356,160 AND 2,286,708. FOR HAIR STYLING PREPARATION (U.S. CLS. 1, 4, 6, 50, 51 AND 52).

FIRST USE 11-1-2011; IN COMMERCE 11-1-2011.

4,119,124. THE DIAL CORPORATION, SCOTTSDALE, AZ. SN 85-050,105. PUB. 11-2-2010, FILED 5-28-2010.

ARCTIC REFRESH

THE MARK CONSISTS OF STANDARD CHARACTERS WITHOUT CLAIM TO ANY PARTICULAR FONT, STYLE, SIZE, OR COLOR.

OWNER OF U.S. REG. NO. 3,569,997. FOR BATH SOAPS; LIQUID SOAP FOR BODY; LIQUID SOAPS (U.S. CLS. 1, 4, 6, 50, 51 AND 52). FIRST USE 12-6-2011; IN COMMERCE 12-6-2011.

CLASS 3—(Continued).

4,119,128. CITRA SOLV, LLC, RIDGEFIELD, CT. SN 85-052,494. PUB. 11-2-2010, FILED 6-2-2010.

HOMESOLV

THE MARK CONSISTS OF STANDARD CHARACTERS WITHOUT CLAIM TO ANY PARTICULAR FONT, STYLE, SIZE, OR COLOR.

OWNER OF U.S. REG. NOS. 1,919,148 AND 2,531,417. NO CLAIM IS MADE TO THE EXCLUSIVE RIGHT TO USE "HOME", APART FROM THE MARK AS SHOWN.

FOR ADHESIVE REMOVERS, ALL PURPOSE CLEANING PREPARATIONS, ALL-PURPOSE CLEANERS, ANTIBACTERIAL SKIN SOAPS, ANTIBACTERIAL SOAP, AROMATIC BODY CARE PRODUCTS, NAMELY, SOAP, AROMATIC ESSENTIAL OILS, AROMATIC OILS, AUTOMATIC DISHWASHING DETERGENTS, AUTOMOBILE CARPET AND UPHOLSTERY CLEANING PREPARATIONS, AUTOMOBILE CLEANERS, AUTOMOBILE TIRE CLEANING AND POLISHING PREPARATIONS, AUTOMOBILE, TIRE, GLASS AND WHEEL CLEANING PREPARATIONS, AUTOMOTIVE CLEANING PREPARATIONS, BAR SOAP, BATH AND SHOWER GELS AND SALTS NOT FOR MEDICAL PURPOSES, BATH SOAPS, BATH SOAPS IN LIQUID, SOLID OR GEL FORM, BIOTECHNOLOGICAL CHEMICAL AND SPRAY CLEANERS FOR INDUSTRIAL AND HOUSEHOLD APPLICATIONS SUCH AS STAIN REMOVAL, ODOR ELIMINATION, AND BIOREMEDIATION OF MANY TYPES OF ORGANIC AND HYDROCARBON-BASED MATERIALS, BIOTECHNOLOGICAL CLEANING SOLUTION FOR ELIMINATING ODORS, BREAKING DOWN ORGANICS, AND REMOVING STAINS, BLEACHING PREPARATIONS FOR HOUSEHOLD USE, BODY WASH, CAKES OF TOILET SOAP, CARPET CLEANERS, CARPET CLEANERS WITH DEODORIZER, CARPET CLEANING PREPARATIONS, CARPET SHAMPOO, CLEANING AGENTS AND PREPARATIONS, CLEANING AGENTS FOR CLEANING SURFACES, CLEANING AND POLISHING PREPARATIONS, CLEANING AND WASHING PREPARATIONS, CLEANING PREPARATIONS FOR HOUSEHOLD PURPOSES, CLEANING PREPARATIONS, CLEANING PREPARATIONS FOR CLEANSING DRAINS, CLEANING PREPARATIONS FOR CLEANING SURFACES, CLEANING PREPARATIONS THAT ELIMINATE BACTERIA THAT CAUSE PRODUCTS TO AGE OR PRODUCE FOUL ODORS, CLEANING PREPARATIONS CONTAINING MICROBIAL ENZYMES, USED TO PRESERVE DRAIN SYSTEMS AND WATERWAYS, CLEANSING AND POLISHING PREPARATIONS, DEGREASING PREPARATIONS FOR VARIOUS TYPES OF SURFACES, DETERGENT SOAP, DETERGENTS FOR AUTOMOBILES, DETERGENTS FOR HOUSEHOLD USE, DETERGENTS FOR MACHINE DISHWASHING, DEGREASING PREPARATIONS FOR HOUSEHOLD PURPOSES, DISH DETERGENTS, DISHWASHER DETERGENTS, DISHWASHING DETERGENTS, DISINFECTANT SOAPS, DISPOSABLE WIPES IMPREGNATED WITH CLEANSING CHEMICALS OR COMPOUNDS FOR HOUSEHOLD USE, DRAIN OPENERS, DRYER SHEETS IMPREGNATED WITH CLEANING GEL AND BAGS FOR USE IN CONNECTION THEREWITH, ESSENTIAL OILS FOR HOUSEHOLD USE, ESSENTIAL

CLASS 3—(Continued).

OILS FOR USE IN AROMATHERAPY, FABRIC SOFTENERS, FABRIC SOFTENERS FOR LAUNDRY USE, FOAM CLEANING PREPARATIONS, FOAM CLEANSERS FOR PERSONAL USE, FRAGRANCE EMITTING WICKS FOR ROOM FRAGRANCE, FURNITURE POLISH, GLASS CLEANERS, GLASS CLEANING PREPARATIONS, GLUE REMOVERS, GUM REMOVING PREPARATIONS, HAND SOAPS, HOUSEHOLD CLEANING PREPARATIONS, LAUNDRY BLEACH, LAUNDRY DETERGENTS, LAUNDRY PRE-SOAK, LIQUID SOAP, OVEN CLEANERS LIQUID SOAPS FOR HANDS, FACE AND BODY, PAINT REMOVER, PET ODOR REMOVERS, PET STAIN REMOVERS, REEDS AND SCENTED OILS SOLD AS A UNIT FOR USE IN ROOM SCENT DIFFUSERS, ROOM FRAGRANCES, SOAPS AND DETERGENTS, SOAPS FOR HOUSEHOLD USE, SOAPS FOR PERSONAL USE, SPOT REMOVER, STAIN REMOVERS, STAIN REMOVING PREPARATIONS, TOILET BOWL DETERGENTS, UPHOLSTERY CLEANERS, WOOD CONDITIONER, BRIGHTENER AND RENEWER (U.S. CLS. 1, 4, 6, 50, 51 AND 52).

FIRST USE 6-22-2011; IN COMMERCE 6-22-2011.

CLASS 3—(Continued).

4,119,140. JOHNSON & JOHNSON, NEW BRUNSWICK, NJ. SN 85-056,130. PUB. 5-31-2011, FILED 6-7-2010.



THE COLOR(S) PURPLE AND CREAM IS/ARE CLAIMED AS A FEATURE OF THE MARK.

THE MARK CONSISTS OF TRADE DRESS ON THE PACKAGING FOR THE GOODS IN THE NATURE OF A CREAM CAP AND THE BODY OF THE BOTTLE FEATURING GRADATIONS OF PURPLE AT THE BOTTOM AND GETTING LIGHTER TOWARDS THE MIDDLE AND CREAM TOWARDS THE TOP WITH A PURPLE LUPIN FLOWER DESIGN. THE BROKEN LINES DEPICTING THE OUTLINE OF THE PRODUCT PACKAGING INDICATE PLACEMENT OF THE MARK ON THE GOODS AND ARE NOT PART OF THE MARK.

FOR HAIR CARE PREPARATIONS, NAMELY, SHAMPOO (U.S. CLS. 1, 4, 6, 50, 51 AND 52).

FIRST USE 1-12-2011; IN COMMERCE 1-12-2011.

4,119,139. JOHNSON & JOHNSON, NEW BRUNSWICK, NJ. SN 85-056,124. PUB. 5-10-2011, FILED 6-7-2010.



THE COLOR(S) BROWN, PURPLE AND CREAM IS/ARE CLAIMED AS A FEATURE OF THE MARK.

THE MARK CONSISTS OF TRADE DRESS ON THE PACKAGING FOR THE GOODS IN THE NATURE OF A LIGHT BROWN CAP AND THE BODY OF THE BOTTLE FEATURING GRADATIONS OF PURPLE AT THE BOTTOM AND GETTING LIGHTER TOWARDS THE MIDDLE AND CREAM TOWARDS THE TOP WITH A PURPLE LUPIN FLOWER DESIGN. THE BROKEN LINES DEPICTING THE OUTLINE OF THE PRODUCT PACKAGING INDICATE PLACEMENT OF THE MARK ON THE GOODS AND ARE NOT PART OF THE MARK.

FOR HAIR CARE PREPARATIONS, NAMELY, CONDITIONER (U.S. CLS. 1, 4, 6, 50, 51 AND 52).

FIRST USE 1-12-2011; IN COMMERCE 1-12-2011.

4,119,150. BLACKSMITH BRANDS, INC., IRVINGTON, NY. SN 85-060,960. PUB. 11-9-2010, FILED 6-11-2010.

**Efferdent Power Clean
Crystals**

THE MARK CONSISTS OF STANDARD CHARACTERS WITHOUT CLAIM TO ANY PARTICULAR FONT, STYLE, SIZE, OR COLOR.

OWNER OF U.S. REG. NOS. 728,959, 3,555,227, AND OTHERS.

NO CLAIM IS MADE TO THE EXCLUSIVE RIGHT TO USE "CLEAN CRYSTALS", APART FROM THE MARK AS SHOWN.

FOR DENTURE CLEANERS; DENTURE CLEANING PREPARATIONS (U.S. CLS. 1, 4, 6, 50, 51 AND 52).

FIRST USE 12-27-2011; IN COMMERCE 12-27-2011.

CLASS 3—(Continued).

4,119,182. JAMES BAHCALL, BUFFALO GROVE, IL. SN 85-077,066. PUB. 6-7-2011, FILED 7-2-2010.

PAPER SHOWER

THE MARK CONSISTS OF STANDARD CHARACTERS WITHOUT CLAIM TO ANY PARTICULAR FONT, STYLE, SIZE, OR COLOR.

FOR DRY WIPES AND DISPOSABLE WIPES IMPREGNATED WITH A SOLUTION FOR APPLICATION TO THE BODY FOR PERSONAL HYGIENE USE (U.S. CLS. 1, 4, 6, 50, 51 AND 52).

FIRST USE 9-30-2010; IN COMMERCE 9-30-2010.

4,119,193. RENUSKIN, LLC, GRAND RAPIDS, MI. SN 85-083,800. PUB. 12-14-2010, FILED 7-13-2010.

TURO SKIN

THE MARK CONSISTS OF STANDARD CHARACTERS WITHOUT CLAIM TO ANY PARTICULAR FONT, STYLE, SIZE, OR COLOR.

NO CLAIM IS MADE TO THE EXCLUSIVE RIGHT TO USE "SKIN", APART FROM THE MARK AS SHOWN.

FOR NON-MEDICATED GROOMING PREPARATIONS FOR MEN, NAMELY, SHAVING PREPARATIONS, LIQUID SOAP FOR FACE AND BODY, SHAMPOO, FACIAL MOISTURIZER WITH SPF, RETINOL CREAM FOR COSMETIC PURPOSES, AND NON-MEDICATED LIP BALM (U.S. CLS. 1, 4, 6, 50, 51 AND 52).

FIRST USE 2-1-2012; IN COMMERCE 2-1-2012.

4,119,194. RENUSKIN, LLC, GRAND RAPIDS, MI. SN 85-083,825. PUB. 12-14-2010, FILED 7-13-2010.

TURO SKIN

NO CLAIM IS MADE TO THE EXCLUSIVE RIGHT TO USE "SKIN", APART FROM THE MARK AS SHOWN.

CLASS 3—(Continued).

THE MARK CONSISTS OF THE LETTER SEQUENCE "TURO" IN STYLIZED FONT, WITH THE VERTICAL ELEMENT OF THE LETTER "R" OMITTED, AND THE WORD "SKIN", ROTATED 90 DEGREES CLOCKWISE, ADJACENT TO THE LETTER "O".

FOR NON-MEDICATED GROOMING PREPARATIONS FOR MEN, NAMELY, SHAVING PREPARATIONS, LIQUID SOAP FOR FACE AND BODY, SHAMPOO, FACIAL MOISTURIZER WITH SPF, RETINOL CREAM FOR COSMETIC PURPOSES, AND NON-MEDICATED LIP BALM (U.S. CLS. 1, 4, 6, 50, 51 AND 52).

FIRST USE 2-1-2012; IN COMMERCE 2-1-2012.

4,119,199. SCENTSHOTS, LLC, KATONAH, NY. SN 85-088,554. PUB. 5-31-2011, FILED 7-20-2010.



NO CLAIM IS MADE TO THE EXCLUSIVE RIGHT TO USE "SCENT", APART FROM THE MARK AS SHOWN.

THE MARK CONSISTS OF "SCENT SHOTS", "SCENT IS GOOD", AND THREE WISPS ABOVE THE "S" IN "SCENT".

FOR ESSENTIAL OILS (U.S. CLS. 1, 4, 6, 50, 51 AND 52).

FIRST USE 10-15-2010; IN COMMERCE 10-15-2010.

4,119,200. SCENTSHOTS, LLC, KATONAH, NY. SN 85-088,610. PUB. 5-31-2011, FILED 7-20-2010.



NO CLAIM IS MADE TO THE EXCLUSIVE RIGHT TO USE "SCENT", APART FROM THE MARK AS SHOWN.

THE MARK CONSISTS OF "ENERGY SCENT", "CATCH THE WAVE", AND A DESIGN ELEMENT SLIGHTLY ABOVE AND TO THE LEFT OF THE WORDS.

FOR ESSENTIAL OILS (U.S. CLS. 1, 4, 6, 50, 51 AND 52).

FIRST USE 10-15-2010; IN COMMERCE 10-15-2010.

CLASS 3—(Continued).

4,119,201. SCENTSHOTS, LLC, KATONAH, NY. SN 85-088,669. PUB. 5-31-2011, FILED 7-20-2010.



NO CLAIM IS MADE TO THE EXCLUSIVE RIGHT TO USE "SCENT", APART FROM THE MARK AS SHOWN.

THE MARK CONSISTS OF "THIN SCENT", "CUT YOUR CORE", AND A DESIGN ELEMENT TO THE LEFT OF THE WORDS.

FOR ESSENTIAL OILS (U.S. CLS. 1, 4, 6, 50, 51 AND 52).

FIRST USE 10-15-2010; IN COMMERCE 10-15-2010.

CLASS 3—(Continued).

4,119,363. AA ENERGIES, LTD., CENTRAL, HONG KONG, HONG KONG. SN 85-190,663. PUB. 4-19-2011, FILED 12-3-2010.

ATLAS & PLEIONE

THE MARK CONSISTS OF STANDARD CHARACTERS WITHOUT CLAIM TO ANY PARTICULAR FONT, STYLE, SIZE, OR COLOR.

FOR COSMETIC CREAMS; COSMETIC MASKS; COSMETIC OILS; COSMETICS AND COSMETIC PREPARATIONS; COSMETICS AND MAKE-UP; DENTIFRICES; DEODORANTS AND ANTIPERSPIRANTS FOR PERSONAL USE; ESSENTIAL OILS; ESSENTIAL OILS AS PERFUME FOR LAUNDRY PURPOSES; HAIR SHAMPOOS AND CONDITIONERS; LAUNDRY DETERGENTS; LAUNDRY FABRIC CONDITIONER; LAUNDRY SOAP; LIPSTICK; MAKE-UP REMOVER; PERFUME OILS; PERFUME OILS FOR THE MANUFACTURE OF COSMETIC PREPARATIONS; PERFUMES; PERFUMES AND COLOGNES; PERFUMES AND TOILET WATERS; SOAPS AND DETERGENTS; SOAPS FOR BODY CARE; SOAPS FOR PERSONAL USE; WASHING PREPARATIONS AND LAUNDRY BLEACH (U.S. CLS. 1, 4, 6, 50, 51 AND 52).

FIRST USE 3-1-2010; IN COMMERCE 9-1-2010.

4,119,333. SALON COMMODITIES, INC., MELROSE PARK, IL. SN 85-180,181. PUB. 5-3-2011, FILED 11-18-2010.

**THE SEXY SIDE OF SCIENCE**

THE MARK CONSISTS OF STANDARD CHARACTERS WITHOUT CLAIM TO ANY PARTICULAR FONT, STYLE, SIZE, OR COLOR.

FOR INDOOR AND OUTDOOR NON-MEDICATED SKIN TANNING PREPARATIONS (U.S. CLS. 1, 4, 6, 50, 51 AND 52).

FIRST USE 11-1-2011; IN COMMERCE 11-1-2011.

4,119,389. THE PROCTER & GAMBLE COMPANY, CINCINNATI, OH. SN 85-198,255. PUB. 4-26-2011, FILED 12-15-2010.

PURE RINSE FORMULA

THE MARK CONSISTS OF THE LITERAL TERM "JOY" AND THE BUST AND ARM OF A WOMEN WEARING A HOOP EARRINGS AND A BRACELET, WITH SPARKLE ACCENTS ON THE HOOP EARRINGS, BRACELET, AND THE LETTER "J".

FOR HAIR CARE PRODUCTS, NAMELY, HAIR CLEANSERS, CONDITIONERS, EMOLLIENT HAIR SPRAYS, STYLING GELS, STYLING CREAMES AND SHINE, MOISTURIZING CREAMS, LOTIONS, OILS, SCALP CLEANSERS AND CONDITIONERS, AND ORGANIC HAIR COLOR ENHANCERS (U.S. CLS. 1, 4, 6, 50, 51 AND 52).

FIRST USE 11-16-2010; IN COMMERCE 11-15-2011.

THE MARK CONSISTS OF STANDARD CHARACTERS WITHOUT CLAIM TO ANY PARTICULAR FONT, STYLE, SIZE, OR COLOR.

CLASS 3—(Continued).

NO CLAIM IS MADE TO THE EXCLUSIVE RIGHT TO USE "RINSE FORMULA", APART FROM THE MARK AS SHOWN.

FOR AUTOMATIC DISH WASHING DETERGENT (U.S. CLS. 1, 4, 6, 50, 51 AND 52).

FIRST USE 9-28-1999; IN COMMERCE 9-28-1999.

4,119,396. AMERICAN INTERNATIONAL INDUSTRIES, COMMERCE, CA. SN 85-198,939. PUB. 5-3-2011, FILED 12-15-2010.

SO EASY

THE MARK CONSISTS OF STANDARD CHARACTERS WITHOUT CLAIM TO ANY PARTICULAR FONT, STYLE, SIZE, OR COLOR.

FOR ADHESIVES FOR AFFIXING FALSE HAIR; ADHESIVES FOR ARTIFICIAL NAILS; ADHESIVES FOR FALSE EYELASHES, HAIR AND NAILS; AFTER-SUN GELS; AFTER-SUN OILS; ALOE VERA GEL FOR COSMETIC PURPOSES; ASTRINGENTS FOR COSMETIC PURPOSES; BABY HAIR CONDITIONER; BABY SHAMPOO; BATH OILS FOR COSMETIC PURPOSES; BATH POWDER; BLEACHING PREPARATIONS FOR COSMETIC PURPOSES; BLEACHING PREPARATIONS FOR THE HAIR; BODY AND BEAUTY CARE COSMETICS; CLEANER FOR COSMETIC BRUSHES; CLEANSING CREAMS; COCOA BUTTER FOR COSMETIC PURPOSES; COSMETIC CREAMS; COSMETIC CREAMS FOR SKIN CARE; COSMETIC HAIR DRESSING PREPARATIONS; COSMETIC HAND CREAMS; COSMETIC MASKS; COSMETIC MASSAGE CREAMS; COSMETIC PENCILS; COSMETIC PREPARATIONS; COSMETIC PREPARATIONS FOR BODY CARE; COSMETIC PREPARATIONS FOR EYE LASHES; COSMETIC PREPARATIONS FOR SKIN CARE; COSMETIC PREPARATIONS FOR SKIN RENEWAL; COSMETIC PREPARATIONS FOR THE CARE OF MOUTH AND TEETH; COSMETIC PREPARATIONS FOR THE HAIR AND SCALP; COSMETIC PREPARATIONS, NAMELY, FIRMING CREAMS; COSMETIC SKIN FRESHENERS; COSMETIC SOAPS; COSMETIC SUN-PROTECTING PREPARATIONS; COSMETICS; COSMETICS AND COSMETIC PREPARATIONS; COSMETICS AND MAKE-UP; COTTON WOOL BALLS FOR COSMETIC USE; CUTICLE CONDITIONERS; EYE GELS; EYE MAKE-UP; EYE PENCILS; EYE SHADOW; EYE SHADOWS; EYEBROW COSMETICS; EYES PENCILS; FACE AND BODY MILK; FACE CREAMS; FACE CREAMS FOR COSMETIC USE; FACE GLITTER; FACE POWDER; FALSE NAILS; FOOT POWDER; FOOT SCRUBS; GAUZE FOR COSMETIC PURPOSES; GLITTER FOR COSMETIC PURPOSES; HAIR CONDITIONER; HAIR SHAMPOO; HAIR SHAMPOOS AND CONDITIONERS; HENNA FOR COSMETIC PURPOSES; LIQUID SOAPS FOR HANDS AND FACE; LOTIONS FOR COSMETIC PURPOSES; MOISTURIZING SOLUTIONS FOR THE SKIN; NAIL BUFFING PREPARATIONS; NAIL CARE PREPARATIONS, NAMELY, NAIL SOFTENERS; NAIL CREAM; NAIL ENAMEL; NAIL ENAMEL REMOVERS; NAIL GEL; NAIL HARDENERS; NAIL POLISH; NAIL POLISH BASE COAT; NAIL POLISH REMOVER; NAIL POLISH TOP COAT; NAIL TIPS; NAIL VARNISH; NAIL VARNISH FOR COSMETIC PURPOSES; NON-MEDICATED FOOT CREAM; NON-MEDICATED HAIR TREATMENT PREPARATIONS FOR COSMETIC PURPOSES; NON-MEDICATED SKIN CARE CREAMS

CLASS 3—(Continued).

AND LOTIONS; NON-MEDICATED SKIN CARE PREPARATIONS; NON-MEDICATED SKIN CREAMS; OILS FOR COSMETIC PURPOSES; PARAFFIN WAX FOR COSMETIC PURPOSES; PERFUME; PERFUME OILS; PERFUME OILS FOR THE MANUFACTURE OF COSMETIC PREPARATIONS; PERFUMED POWDER; PERFUMED SOAP; PETROLEUM JELLY FOR COSMETIC PURPOSES; PRE-MOISTENED COSMETIC TISSUES; SELF-TANNING PREPARATIONS; SHAMPOO-CONDITIONERS; SHAMPOOS FOR BABIES; SHEA BUTTER FOR COSMETIC PURPOSES; SKIN AND BODY TOPICAL LOTIONS, CREAMS AND OILS FOR COSMETIC USE; SKIN CONDITIONERS; SKIN CREAMS; SKIN EMOLLIENTS; SKIN LOTION; SKIN MASKS; SKIN MOISTURIZER; SKIN SOAP; SKIN TONERS; TANNING GELS; TANNING OILS; TEETH WHITENING STRIPS IMPREGNATED WITH TEETH WHITENING PREPARATIONS; TOOTHPASTE; TOOTHPASTE AND MOUTHWASHES; WRINKLE-MINIMIZING COSMETIC PREPARATIONS FOR TOPICAL FACIAL USE (U.S. CLS. 1, 4, 6, 50, 51 AND 52).

FIRST USE 3-15-2001; IN COMMERCE 3-15-2001.

4,119,416. PACIFIC SUNWEAR OF CALIFORNIA, INC., ANAHEIM, CA. SN 85-202,935. PUB. 5-10-2011, FILED 12-21-2010.

BLACK POPPY

THE MARK CONSISTS OF STANDARD CHARACTERS WITHOUT CLAIM TO ANY PARTICULAR FONT, STYLE, SIZE, OR COLOR.

OWNER OF U.S. REG. NOS. 3,835,985 AND 3,881,036. FOR FRAGRANCES FOR PERSONAL USE, PERFUMES, SCENTED BODY SPRAY AND NAIL POLISH (U.S. CLS. 1, 4, 6, 50, 51 AND 52).

FIRST USE 12-1-2011; IN COMMERCE 12-1-2011.

4,119,438. BEYOND DENTAL & HEALTH, INC., STAFFORD, TX. SN 85-208,407. PUB. 5-3-2011, FILED 12-30-2010.

SOLO

THE MARK CONSISTS OF STANDARD CHARACTERS WITHOUT CLAIM TO ANY PARTICULAR FONT, STYLE, SIZE, OR COLOR.

FOR TEETH WHITENING KITS (U.S. CLS. 1, 4, 6, 50, 51 AND 52).

FIRST USE 10-3-2011; IN COMMERCE 10-3-2011.

CLASS 3—(Continued).

4,119,481. AVEDA CORPORATION, MINNEAPOLIS, MN. SN 85-221,150. PUB. 5-31-2011, FILED 1-19-2011.

INTENSE DETOXIFIER

THE MARK CONSISTS OF STANDARD CHARACTERS WITHOUT CLAIM TO ANY PARTICULAR FONT, STYLE, SIZE, OR COLOR.

NO CLAIM IS MADE TO THE EXCLUSIVE RIGHT TO USE "DETOXIFIER", APART FROM THE MARK AS SHOWN.

FOR COSMETIC PREPARATIONS FOR THE HAIR AND SCALP; HAIR CARE PREPARATIONS (U.S. CLS. 1, 4, 6, 50, 51 AND 52).

FIRST USE 8-6-2011; IN COMMERCE 8-6-2011.

4,119,505. SALONQUEST, LLC, CHAGRIN FALLS, OH. SN 85-225,975. PUB. 5-31-2011, FILED 1-25-2011.

TEXT ME

THE MARK CONSISTS OF STANDARD CHARACTERS WITHOUT CLAIM TO ANY PARTICULAR FONT, STYLE, SIZE, OR COLOR.

FOR HAIR CARE PREPARATIONS, NAMELY, HAIR TEXTURIZER (U.S. CLS. 1, 4, 6, 50, 51 AND 52).

FIRST USE 3-15-2011; IN COMMERCE 3-15-2011.

4,119,614. PHIT HAIR AND BODY, INC., SOLANA BEACH, CA. SN 85-280,319. PUB. 8-9-2011, FILED 3-29-2011.

THE MARK CONSISTS OF THE STYLIZED WORD PHIT IN ALL LOWER CASE WITH PART OF THE ROUNDED PORTION OF THE STYLIZED LETTER "P" MERGING

CLASS 3—(Continued).

WITH THE VERTICAL PORTION OF THE STYLIZED LETTER "H" AND THE HORIZONTAL CROSS PORTION OF THE STYLIZED LETTER "T" CONNECTED TO AND MERGING WITH THE VERTICAL PORTION OF THE STYLIZED LETTER "I", THE "I" INCLUDING A SQUARE SHAPED DOT DIRECTLY ABOVE. THE STYLIZED FONT OF THE MARK "PHIT" IS CUSTOMIZED, CREATED UNIQUELY FOR THE MARK. THE COLOR BLACK DENOTES OUTLINING OF THE STYLIZED LETTERS AND BLOCK DOT ONLY; NO COLOR IS CLAIMED.

FOR BODY WASH; HAIR CARE PREPARATIONS; HAIR SHAMPOOS AND CONDITIONERS; NON-MEDICATED BALMS FOR USE ON SKIN, FACE, NAILS AND LIPS; NON-MEDICATED SKIN CARE, NAIL CARE AND FACIAL CARE PREPARATIONS (U.S. CLS. 1, 4, 6, 50, 51 AND 52).

FIRST USE 11-1-2011; IN COMMERCE 11-1-2011.

4,119,669. L'OREAL USA CREATIVE, INC., NEW YORK, NY. SN 85-313,546. PUB. 9-20-2011, FILED 5-5-2011.

LUXEEFFECTS

THE MARK CONSISTS OF STANDARD CHARACTERS WITHOUT CLAIM TO ANY PARTICULAR FONT, STYLE, SIZE, OR COLOR.

FOR NAIL POLISH, NAIL POLISH TOP COAT, AND NAIL GLITTER (U.S. CLS. 1, 4, 6, 50, 51 AND 52).

FIRST USE 12-15-2011; IN COMMERCE 12-15-2011.

4,119,686. CREATIVE RESEARCH LABS, INC., WAKE FOREST, NC. SN 85-326,340. PUB. 11-15-2011, FILED 5-20-2011.

THE MARK CONSISTS OF STANDARD CHARACTERS WITHOUT CLAIM TO ANY PARTICULAR FONT, STYLE, SIZE, OR COLOR.

THE NAME(S), PORTRAIT(S), AND/OR SIGNATURE(S) SHOWN IN THE MARK IDENTIFIES ROSELLE JULIE GUTIERREZ, WHOSE CONSENT(S) TO REGISTER IS MADE OF RECORD.

FOR COSMETICS (U.S. CLS. 1, 4, 6, 50, 51 AND 52). FIRST USE 8-12-2011; IN COMMERCE 8-12-2011.

CLASS 3—(Continued).

4,119,692. KEITH WOODS, RIVERDALE, GA. SN 85-333,255.
PUB. 11-22-2011, FILED 5-29-2011.



NO CLAIM IS MADE TO THE EXCLUSIVE RIGHT TO USE "TAJA", APART FROM THE MARK AS SHOWN.

THE COLOR(S) LIGHT BLUE, DARK BLUE, WHITE AND SILVER IS/ARE CLAIMED AS A FEATURE OF THE MARK.

THE MARK CONSISTS OF AN OVAL, LIGHT BLUE COUNTERCLOCKWISE SWIRL ENCLOSING A LIGHT BLUE CIRCLE WITH A WHITE REFLECTION IMAGE AT THE TOP OF THE CIRCLE. THE LIGHT BLUE CIRCLE IS SURROUNDED BY DARK BLUE AND SILVER CIRCULAR BORDERS THAT ARE SHAPED LIKE CLOSED PARENTHESES, AND THE WORD "TAJA" IN DARK BLUE, STYLIZED FORMAT IS SUPERIMPOSED OVER THE SWIRLS AND CIRCLES.

THE ENGLISH TRANSLATION OF "TAJA" IN THE MARK IS "FRESH".

FOR LAUNDRY DETERGENT (U.S. CLS. 1, 4, 6, 50, 51 AND 52).

FIRST USE 5-13-2011; IN COMMERCE 12-28-2011.

4,119,701. AWESOME PRODUCTS, INC., BUENA PARK, CA.
SN 85-340,885. PUB. 11-1-2011, FILED 6-8-2011.

LA'S TOTALLY AWESOME

THE MARK CONSISTS OF STANDARD CHARACTERS WITHOUT CLAIM TO ANY PARTICULAR FONT, STYLE, SIZE, OR COLOR.

FOR PET SHAMPOO (U.S. CLS. 1, 4, 6, 50, 51 AND 52).
FIRST USE 1-1-1998; IN COMMERCE 1-1-1998.

CLASS 3—(Continued).

4,119,702. AWESOME PRODUCTS, INC., BUENA PARK, CA.
SN 85-340,904. PUB. 11-1-2011, FILED 6-8-2011.

LA'S TOTALLY AWESOME

THE MARK CONSISTS OF STANDARD CHARACTERS WITHOUT CLAIM TO ANY PARTICULAR FONT, STYLE, SIZE, OR COLOR.

FOR AUTOMOBILE CARE PRODUCTS, NAMELY, WHEEL AND TIRE CLEANING PREPARATIONS, UPHOLSTERY CLEANING PREPARATIONS, DEGREASER AND SPOT REMOVER PREPARATIONS (U.S. CLS. 1, 4, 6, 50, 51 AND 52).

FIRST USE 1-1-1997; IN COMMERCE 1-1-1997.

CLASS 4—LUBRICANTS AND FUELS

4,119,519. UNITED NATURAL FOODS, INC., PROVIDENCE, RI. SN 85-230,675. PUB. 6-7-2011, FILED 1-31-2011.

EAT BECAUSE IT'S GOOD!

THE MARK CONSISTS OF STANDARD CHARACTERS WITHOUT CLAIM TO ANY PARTICULAR FONT, STYLE, SIZE, OR COLOR.

FOR CHARCOAL (U.S. CLS. 1, 6 AND 15).

FIRST USE 5-0-2011; IN COMMERCE 5-0-2011.

4,119,685. ROYAL OAK ENTERPRISES, LLC, ROSWELL, GA. SN 85-326,272. PUB. 10-25-2011, FILED 5-20-2011.

RIDGE

THE MARK CONSISTS OF STANDARD CHARACTERS WITHOUT CLAIM TO ANY PARTICULAR FONT, STYLE, SIZE, OR COLOR.

FOR CHARCOAL BRIQUETTES (U.S. CLS. 1, 6 AND 15).

FIRST USE 12-27-2011; IN COMMERCE 12-27-2011.

CLASS 5—PHARMACEUTICALS

CLASS 5—(Continued).

4,118,810. CHAN ENTERPRISES, INC., REDONDO BEACH, CA. SN 77-380,035. PUB. 9-30-2008, FILED 1-24-2008.

STEVIA WONDER

THE MARK CONSISTS OF STANDARD CHARACTERS WITHOUT CLAIM TO ANY PARTICULAR FONT, STYLE, SIZE, OR COLOR.

NO CLAIM IS MADE TO THE EXCLUSIVE RIGHT TO USE "STEVIA", APART FROM THE MARK AS SHOWN.

FOR DIETARY AND NUTRITIONAL SUPPLEMENTS CONTAINING STEVIA EXTRACT; DIETARY FOOD SUPPLEMENTS; DIETARY SUPPLEMENTS; DIETARY SUPPLEMENTS FOR HUMAN CONSUMPTION; NUTRITIONAL STEVIA-BASED ADDITIVES FOR MEDICAL PURPOSES FOR USE IN FOODS AND DIETARY SUPPLEMENTS FOR HUMAN CONSUMPTION; POWDERED FRUIT-FLAVORED DIETARY SUPPLEMENT DRINK MIX CONTAINING STEVIA EXTRACT (U.S. CLS. 6, 18, 44, 46, 51 AND 52).

FIRST USE 12-1-2011; IN COMMERCE 12-1-2011.

4,118,843. NANOSYS, INC., PALO ALTO, CA. SN 77-492,275. PUB. 10-28-2008, FILED 6-5-2008.



THE MARK CONSISTS OF A STYLIZED RIBBON WITH SMALL CIRCLE REMOVED AT UPPER EDGE.

FOR MEDICAL ADHESIVES FOR BINDING WOUNDS (U.S. CLS. 6, 18, 44, 46, 51 AND 52).

FIRST USE 6-21-2010; IN COMMERCE 6-21-2010.

4,118,860. GALLINA, HUNT, GERMANTOWN, TN. SN 77-505,481. PUB. 11-11-2008, FILED 6-23-2008.

SUTURESELF

THE MARK CONSISTS OF STANDARD CHARACTERS WITHOUT CLAIM TO ANY PARTICULAR FONT, STYLE, SIZE, OR COLOR.

FOR WOUND TREATMENT MEDICAMENTS IN LIQUID, OINTMENT, LOTION, CREAM OR PASTE FORM (U.S. CLS. 6, 18, 44, 46, 51 AND 52).

FIRST USE 2-3-2012; IN COMMERCE 2-3-2012.

CLASS 5—(Continued).

4,118,911. ARLEN, MICHAEL W., DBA ARLEN NUTRACEUTICALS, LOS ANGELES, CA. SN 77-718,740. PUB. 1-12-2010, FILED 4-21-2009.

Function-ala-Teas

THE COLOR(S) DARK GREEN, LIGHT GREEN, AND BROWN IS/ARE CLAIMED AS A FEATURE OF THE MARK.

THE MARK CONSISTS OF THE WORDS "FUNCTION-ALA-TEAS" IN A SCRIPT FONT WITH A LIGHT GREEN LEAF AS THE DOT OVER THE "I". THE COLOR GREEN APPEARS IN THE WORDING "FUNCTION" AND "TEAS" AND THE COLOR BROWN APPEARS IN THE WORDING "ALA".

FOR NUTRITIONALLY FORTIFIED DRY POWDER MIXES (U.S. CLS. 6, 18, 44, 46, 51 AND 52).

FIRST USE 11-30-2011; IN COMMERCE 11-30-2011.

4,118,925. A.P. PHARMA, INC., REDWOOD CITY, CA. SN 77-765,494. PUB. 11-3-2009, FILED 6-22-2009.

SUSTOL

THE MARK CONSISTS OF STANDARD CHARACTERS WITHOUT CLAIM TO ANY PARTICULAR FONT, STYLE, SIZE, OR COLOR.

FOR ANTI-EMETIC PHARMACEUTICAL PREPARATIONS; PHARMACEUTICAL PREPARATIONS FOR THE TREATMENT OF CANCER AND GASTROINTESTINAL CONDITIONS (U.S. CLS. 6, 18, 44, 46, 51 AND 52).

FIRST USE 12-1-2011; IN COMMERCE 12-1-2011.

4,118,931. ARLEN, MICHAEL W., DBA ARLEN NUTRACEUTICALS, LOS ANGELES, CA. SN 77-785,813. PUB. 12-15-2009, FILED 7-21-2009.

Say-Thai-a-Tea

THE MARK CONSISTS OF STANDARD CHARACTERS WITHOUT CLAIM TO ANY PARTICULAR FONT, STYLE, SIZE, OR COLOR.

FOR NUTRITIONALLY FORTIFIED DRY POWDER DRINK MIXES (U.S. CLS. 6, 18, 44, 46, 51 AND 52).

FIRST USE 11-30-2011; IN COMMERCE 11-30-2011.

CLASS 5—(Continued).

4,118,952. JOHNSON & JOHNSON, NEW BRUNSWICK, NJ.
SN 77-848,495. PUB. 3-23-2010, FILED 10-14-2009.



OWNER OF U.S. REG. NOS. 54,124, 1,904,052, AND OTHERS.

THE COLOR(S) WHITE, PINK, RED AND BLUE IS/ARE CLAIMED AS A FEATURE OF THE MARK.

THE MARK CONSISTS OF THE LETTERS "K" AND "Y" IN DARK BLUE WITH A RED DIAMOND IN THE MIDDLE APPEARING AMONG WHITE AND PINK SWIRLS.

FOR VAGINAL MOISTURIZERS (U.S. CLS. 6, 18, 44, 46, 51 AND 52).

FIRST USE 7-16-2010; IN COMMERCE 7-16-2010.

4,118,962. USP LABS, LLC, DALLAS, TX. SN 77-869,916. PUB. 3-16-2010, FILED 11-11-2009.

COMPOUND 20

THE MARK CONSISTS OF STANDARD CHARACTERS WITHOUT CLAIM TO ANY PARTICULAR FONT, STYLE, SIZE, OR COLOR.

NO CLAIM IS MADE TO THE EXCLUSIVE RIGHT TO USE "COMPOUND", APART FROM THE MARK AS SHOWN.

FOR DIETARY SUPPLEMENTS (U.S. CLS. 6, 18, 44, 46, 51 AND 52).

FIRST USE 12-21-2011; IN COMMERCE 12-21-2011.

CLASS 5—(Continued).

4,118,993. JOHNSON & JOHNSON, NEW BRUNSWICK, NJ.
SN 77-909,667. PUB. 6-14-2011, FILED 1-12-2010.

ACTI-FRESH

THE MARK CONSISTS OF STANDARD CHARACTERS WITHOUT CLAIM TO ANY PARTICULAR FONT, STYLE, SIZE, OR COLOR.

OWNER OF U.S. REG. NO. 3,709,690.

FOR FEMININE HYGIENE PRODUCTS, NAMELY, PANTY LINERS AND PANTY SHIELDS (U.S. CLS. 6, 18, 44, 46, 51 AND 52).

FIRST USE 3-14-2011; IN COMMERCE 3-14-2011.

4,119,152. I AM PRODUCTS, LLC, WASHINGTON CROSSING, PA. SN 85-063,864. PUB. 11-16-2010, FILED 6-15-2010.

I AM FOCUSED

THE MARK CONSISTS OF STANDARD CHARACTERS WITHOUT CLAIM TO ANY PARTICULAR FONT, STYLE, SIZE, OR COLOR.

FOR NUTRITIONAL SUPPLEMENTS IN THE NATURE OF VITAMIN, MINERAL, AND HERB DRINKS (U.S. CLS. 6, 18, 44, 46, 51 AND 52).

FIRST USE 11-30-2011; IN COMMERCE 11-30-2011.

4,119,160. NORBROOK LABORATORIES LIMITED, NEWRY, COUNTY DOWN, NORTHERN IRELAND. SN 85-067,467. PUB. 5-31-2011, FILED 6-21-2010.

NOROMYCIN

THE MARK CONSISTS OF STANDARD CHARACTERS WITHOUT CLAIM TO ANY PARTICULAR FONT, STYLE, SIZE, OR COLOR.

FOR PHARMACEUTICAL AND VETERINARY PREPARATIONS AND SUBSTANCES, NAMELY, ANTIBIOTICS (U.S. CLS. 6, 18, 44, 46, 51 AND 52).

FIRST USE 6-10-2008; IN COMMERCE 6-10-2008.

CLASS 5—(Continued).

4,119,171. BARTON NUTRITIONAL, MIAMI, FL. SN 85-073,264. PUB. 11-23-2010, FILED 6-28-2010.

RenewVita

THE MARK CONSISTS OF STANDARD CHARACTERS WITHOUT CLAIM TO ANY PARTICULAR FONT, STYLE, SIZE, OR COLOR.

FOR VITAMINS (U.S. CLS. 6, 18, 44, 46, 51 AND 52).
FIRST USE 7-16-2011; IN COMMERCE 7-16-2011.

4,119,175. ELIAS, NATIVIDAD R., MIAMI, FL. SN 85-073,843. PUB. 5-24-2011, FILED 6-29-2010.

DR. RUB

THE MARK CONSISTS OF STANDARD CHARACTERS WITHOUT CLAIM TO ANY PARTICULAR FONT, STYLE, SIZE, OR COLOR.

NO CLAIM IS MADE TO THE EXCLUSIVE RIGHT TO USE "RUB", APART FROM THE MARK AS SHOWN.

THE NAME(S), PORTRAIT(S), AND/OR SIGNATURE(S) SHOWN IN THE MARK DOES NOT IDENTIFY A PARTICULAR LIVING INDIVIDUAL.

FOR PREPARATIONS FOR TEMPORARY RELIEF OF COUGH AND COLD SYMPTOMS, NASAL CONGESTION AND RESPIRATORY CONGESTION, NAMELY, COUGH TREATMENT PREPARATIONS, PREPARATIONS FOR TREATING COLDS, NASAL AND RESPIRATORY DECONGESTANTS (U.S. CLS. 6, 18, 44, 46, 51 AND 52).
FIRST USE 12-31-2011; IN COMMERCE 12-31-2011.

4,119,176. LIVON LABORATORIES, INC., HENDERSON, NV. SN 85-074,261. PUB. 11-9-2010, FILED 6-29-2010.

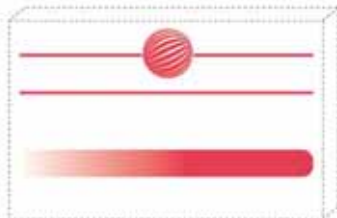

THE COLOR(S) RED IS/ARE CLAIMED AS A FEATURE OF THE MARK.

CLASS 5—(Continued).

THE MARK CONSISTS OF STYLIZED RED SPHERE SUPERIMPOSED OVER A RED LINE, WITH AN ADDITIONAL RED LINE BENEATH OVER AN RED BAR WITH COLOR FADING IN INTENSITY FROM RIGHT TO LEFT. THE SHAPE OF THE PRODUCT PACKAGE IS SHOWN IN DOTTED LINES AND IS NOT CLAIMED AS A FEATURE OF THE MARK.

FOR VITAMINS, DIETARY SUPPLEMENTS, AND FOOD SUPPLEMENTS (U.S. CLS. 6, 18, 44, 46, 51 AND 52).

FIRST USE 8-26-2009; IN COMMERCE 8-26-2009.

4,119,177. LIVON LABORATORIES, INC., HENDERSON, NV. SN 85-074,267. PUB. 11-9-2010, FILED 6-29-2010.

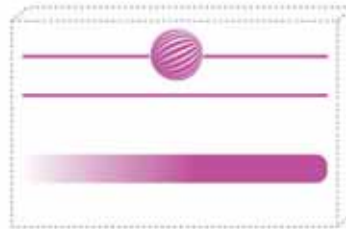

THE COLOR(S) PURPLE IS/ARE CLAIMED AS A FEATURE OF THE MARK.

THE MARK CONSISTS OF STYLIZED PURPLE SPHERE SUPERIMPOSED OVER A PURPLE LINE, WITH AN ADDITIONAL PURPLE LINE BENEATH OVER AN PURPLE BAR WITH COLOR FADING IN INTENSITY FROM RIGHT TO LEFT. THE SHAPE OF THE PRODUCT PACKAGE IS SHOWN IN DOTTED LINES AND IS NOT CLAIMED AS A FEATURE OF THE MARK.

FOR VITAMINS, DIETARY SUPPLEMENTS, AND FOOD SUPPLEMENTS (U.S. CLS. 6, 18, 44, 46, 51 AND 52).

FIRST USE 6-19-2008; IN COMMERCE 6-19-2008.

4,119,181. TRUTEK CORP., HILLSBOROUGH, NJ. SN 85-076,164. PUB. 12-7-2010, FILED 7-1-2010.

NasalGuard Allergie Block

THE MARK CONSISTS OF STANDARD CHARACTERS WITHOUT CLAIM TO ANY PARTICULAR FONT, STYLE, SIZE, OR COLOR.

OWNER OF U.S. REG. NO. 2,758,780.

NO CLAIM IS MADE TO THE EXCLUSIVE RIGHT TO USE "ALLERGY BLOCK", APART FROM THE MARK AS SHOWN.

FOR NON-MEDICATED TOPICAL GEL FOR THE PREVENTION AND TREATMENT OF ALLERGIES (U.S. CLS. 6, 18, 44, 46, 51 AND 52).

FIRST USE 10-1-1911; IN COMMERCE 11-1-1911.

CLASS 5—(Continued).

4,119,216. CHRISTINE VALENZA, HACKENSACK, NJ. SN 85-097,102. PUB. 1-18-2011, FILED 7-30-2010.

FEM-RESC

THE MARK CONSISTS OF STANDARD CHARACTERS WITHOUT CLAIM TO ANY PARTICULAR FONT, STYLE, SIZE, OR COLOR.

FOR FEMININE HYGIENE KITS COMPRISED OF TAMPONS, CLEANSING TOWELETTES, UNDERWEAR, AND DISPOSABLE BAGS (U.S. CLS. 6, 18, 44, 46, 51 AND 52).

FIRST USE 10-1-2011; IN COMMERCE 10-1-2011.

4,119,219. ALVA-AMCO PHARMACAL COS., INC., NILES, IL. SN 85-100,525. PUB. 1-18-2011, FILED 8-4-2010.

ECZEMIN

THE MARK CONSISTS OF STANDARD CHARACTERS WITHOUT CLAIM TO ANY PARTICULAR FONT, STYLE, SIZE, OR COLOR.

FOR MEDICATED COSMETICS; MEDICATED LOTIONS FOR SKIN CARE; MEDICATED SKIN CARE PREPARATIONS; MEDICATED SKIN CARE PREPARATIONS, NAMELY, CREAMS, LOTIONS, GELS, TONERS, CLEANSERS AND PEELS; MEDICINAL CREAMS FOR SKIN CARE; PHARMACEUTICAL PREPARATIONS AND SUBSTANCES FOR THE TREATMENT OF DAMAGED SKIN AND TISSUE; PHARMACEUTICAL PREPARATIONS FOR SKIN CARE; PHARMACEUTICAL PREPARATIONS FOR TREATING SKIN DISORDERS; PHARMACEUTICAL SKIN LOTIONS (U.S. CLS. 6, 18, 44, 46, 51 AND 52).

FIRST USE 11-14-2011; IN COMMERCE 11-14-2011.

CLASS 5—(Continued).

4,119,257. TAVERAS, ANTONIO C., DBA TONY'S ENTERPRISE, PROVIDENCE, RI. SN 85-126,520. PUB. 6-28-2011, FILED 9-10-2010.



THE COLOR(S) BLACK AND GOLD IS/ARE CLAIMED AS A FEATURE OF THE MARK.

THE MARK CONSISTS OF A DESIGN FEATURING A GOLD CRESCENT MOON NEXT TO THE OUTLINE OF A NUDE FEMALE HEAD AND TORSO IN THE COLOR GOLD; TO THE RIGHT OF THE DESIGN APPEARS THE STYLIZED GOLD WORDING "GOLDEN NIGHT"; BENEATH THE MOON AND FEMALE DESIGNS APPEARS THE STYLIZED GOLD WORDING "POWERFUL SEX"; ALL OF THE AFOREMENTIONED APPEAR ON A BLACK BACKGROUND.

FOR DIETARY FOOD SUPPLEMENTS (U.S. CLS. 6, 18, 44, 46, 51 AND 52).

FIRST USE 10-31-2010; IN COMMERCE 8-18-2011.

4,119,282. PFIZER INC., NEW YORK, NY. SN 85-144,534. PUB. 3-15-2011, FILED 10-4-2010.

SKEIGHT

THE MARK CONSISTS OF STANDARD CHARACTERS WITHOUT CLAIM TO ANY PARTICULAR FONT, STYLE, SIZE, OR COLOR.

FOR PHARMACEUTICAL PREPARATIONS FOR THE TREATMENT OF CARDIOVASCULAR, CENTRAL NERVOUS SYSTEM AND METABOLIC DISEASES AND DISORDERS (U.S. CLS. 6, 18, 44, 46, 51 AND 52).

FIRST USE 12-1-2011; IN COMMERCE 12-1-2011.

CLASS 5—(Continued).

4,119,293. KOPPLA LTD., DBA KOPPLA NUTRIENTS, NEW YORK, NY. AND FSI NUTRITION, OMAHA, NE. SN 85-153,882. PUB. 3-29-2011, FILED 10-15-2010.



THE MARK CONSISTS OF STYLIZED TEXT, "CALM-FIDENCE" OUTLINED IN BLACK WITH A WHITE OVAL WITHIN A GRAY OVAL. THE REMAINDER OF WHITE IN THE DRAWING REPRESENTS A TRANSPARENT BACKGROUND THAT IS NOT PART OF THE MARK.

FOR DIETARY BEVERAGE SUPPLEMENTS FOR HUMAN CONSUMPTION IN LIQUID AND DRY MIX FORM FOR THERAPEUTIC PURPOSES; DIETARY SUPPLEMENTS FOR HUMAN CONSUMPTION; DIETARY SUPPLEMENTS FOR RELIEF OF TENSION AND ANXIETY (U.S. CLS. 6, 18, 44, 46, 51 AND 52).

FIRST USE 1-7-2012; IN COMMERCE 1-7-2012.

4,119,361. INTERVET INTERNATIONAL B.V., BOXMEER, NETHERLANDS. SN 85-189,918. PUB. 6-28-2011, FILED 12-3-2010.

EQUI-NILE WNV

THE MARK CONSISTS OF STANDARD CHARACTERS WITHOUT CLAIM TO ANY PARTICULAR FONT, STYLE, SIZE, OR COLOR.

NO CLAIM IS MADE TO THE EXCLUSIVE RIGHT TO USE "WNV", APART FROM THE MARK AS SHOWN.

FOR VETERINARY VACCINE AGAINST WEST NILE VIRUS (U.S. CLS. 6, 18, 44, 46, 51 AND 52).

FIRST USE 6-1-2011; IN COMMERCE 6-1-2011.

4,119,365. H.J. BAKER & BRO., INC., WESTPORT, CT. SN 85-192,975. PUB. 4-19-2011, FILED 12-8-2010.

NUTRI-PAK

THE MARK CONSISTS OF STANDARD CHARACTERS WITHOUT CLAIM TO ANY PARTICULAR FONT, STYLE, SIZE, OR COLOR.

FOR ANIMAL FEED SUPPLEMENTS; NON-MEDICATED ADDITIVES FOR ANIMAL FEED FOR USE AS NUTRITIONAL SUPPLEMENTS (U.S. CLS. 6, 18, 44, 46, 51 AND 52).

FIRST USE 11-28-2010; IN COMMERCE 11-28-2010.

CLASS 5—(Continued).

4,119,386. CARDIUM THERAPEUTICS, INC., SAN DIEGO, CA. SN 85-198,041. PUB. 4-26-2011, FILED 12-15-2010.

CERE-X

THE MARK CONSISTS OF STANDARD CHARACTERS WITHOUT CLAIM TO ANY PARTICULAR FONT, STYLE, SIZE, OR COLOR.

FOR NUTRACEUTICALS USED AS SUPPLEMENTS; HERBAL PREPARATIONS USED AS SUPPLEMENTS (U.S. CLS. 6, 18, 44, 46, 51 AND 52).

FIRST USE 6-15-2011; IN COMMERCE 6-15-2011.

4,119,393. COUNTRY LIFE, LLC, HAUPPAUGE, NY. SN 85-198,487. PUB. 4-26-2011, FILED 12-15-2010.

IMMUNE PREP

THE MARK CONSISTS OF STANDARD CHARACTERS WITHOUT CLAIM TO ANY PARTICULAR FONT, STYLE, SIZE, OR COLOR.

NO CLAIM IS MADE TO THE EXCLUSIVE RIGHT TO USE "IMMUNE", APART FROM THE MARK AS SHOWN.

FOR DIETARY AND NUTRITIONAL SUPPLEMENTS (U.S. CLS. 6, 18, 44, 46, 51 AND 52).

FIRST USE 8-1-2011; IN COMMERCE 8-1-2011.

4,119,401. UNIVERSITY MEDICAL PHARMACEUTICALS CORP., IRVINE, CA. SN 85-199,951. PUB. 5-10-2011, FILED 12-16-2010.

KILLER FOAM

THE MARK CONSISTS OF STANDARD CHARACTERS WITHOUT CLAIM TO ANY PARTICULAR FONT, STYLE, SIZE, OR COLOR.

NO CLAIM IS MADE TO THE EXCLUSIVE RIGHT TO USE "FOAM", APART FROM THE MARK AS SHOWN.

FOR ACNE MEDICATIONS AND ACNE TREATMENT PREPARATIONS (U.S. CLS. 6, 18, 44, 46, 51 AND 52).

FIRST USE 4-11-2011; IN COMMERCE 4-11-2011.

CLASS 5—(Continued).

4,119,466. GRUPO OMNILIFE, S.A. DE C.V., DBA GOM 940311 LF7, GUADALAJARA, JALISCO, MEXICO. SN 85-215,808. PUB. 5-17-2011, FILED 1-12-2011.

CAFEZZINO

THE MARK CONSISTS OF STANDARD CHARACTERS WITHOUT CLAIM TO ANY PARTICULAR FONT, STYLE, SIZE, OR COLOR.

THE WORDING "CAFEZZINO" HAS NO MEANING IN A FOREIGN LANGUAGE.

FOR DIETARY SUPPLEMENTS; MINERAL FOOD SUPPLEMENTS; NUTRITIONAL SUPPLEMENTS; VITAMIN PREPARATIONS (U.S. CLS. 6, 18, 44, 46, 51 AND 52).
FIRST USE 2-5-2011; IN COMMERCE 10-22-2011.

4,119,491. JENNEREX, INC., SAN FRANCISCO, CA. SN 85-222,073. PUB. 8-9-2011, FILED 1-20-2011.

THE MARK CONSISTS OF THE LETTERS "JX" IN STYLIZED FORM.

FOR BIOPHARMACEUTICAL AGENTS IN THE FORM OF ONCOLYTIC VIRUSES FOR THE PREVENTION, DIAGNOSIS, AND TREATMENT OF CANCER; BIOLOGIC PHARMACEUTICAL PREPARATIONS FOR THE PREVENTION, DIAGNOSIS, AND TREATMENT OF CANCER (U.S. CLS. 6, 18, 44, 46, 51 AND 52).

FIRST USE 10-0-2011; IN COMMERCE 10-0-2011.

4,119,521. SUCCESS IN ACTION LLC, RINGGOLD, GA. SN 85-231,078. PUB. 9-13-2011, FILED 2-1-2011.

Fitness Magic

THE MARK CONSISTS OF STANDARD CHARACTERS WITHOUT CLAIM TO ANY PARTICULAR FONT, STYLE, SIZE, OR COLOR.

NO CLAIM IS MADE TO THE EXCLUSIVE RIGHT TO USE "FITNESS", APART FROM THE MARK AS SHOWN.

FOR DIETARY AND NUTRITIONAL SUPPLEMENTS (U.S. CLS. 6, 18, 44, 46, 51 AND 52).

FIRST USE 10-29-2009; IN COMMERCE 12-15-2009.

CLASS 5—(Continued).

4,119,603. GLOBAL HEALTH PRODUCTS, INC., ROCHESTER, NY. SN 85-271,932. PUB. 8-2-2011, FILED 3-21-2011.

Prep-It

THE MARK CONSISTS OF STANDARD CHARACTERS WITHOUT CLAIM TO ANY PARTICULAR FONT, STYLE, SIZE, OR COLOR.

FOR MEDICAL CLEANSERS FOR SKIN AND WOUNDS (U.S. CLS. 6, 18, 44, 46, 51 AND 52).

FIRST USE 5-15-2011; IN COMMERCE 9-15-2011.

4,119,628. VELOX PRODUCTS, LLC, WESTON, FL. SN 85-291,853. PUB. 8-23-2011, FILED 4-11-2011.

Velox

THE MARK CONSISTS OF STANDARD CHARACTERS WITHOUT CLAIM TO ANY PARTICULAR FONT, STYLE, SIZE, OR COLOR.

FOR DIETARY AND NUTRITIONAL SUPPLEMENTS (U.S. CLS. 6, 18, 44, 46, 51 AND 52).

FIRST USE 11-24-2011; IN COMMERCE 11-24-2011.

4,119,650. R & D LIFESCIENCES, LLC, MENOMONIE, WI. SN 85-300,018. PUB. 9-6-2011, FILED 4-20-2011.

SILAMACE

THE MARK CONSISTS OF STANDARD CHARACTERS WITHOUT CLAIM TO ANY PARTICULAR FONT, STYLE, SIZE, OR COLOR.

FOR NON MEDICATED ADDITIVE FOR ANIMAL FEED FOR USE AS NUTRITIONAL SUPPLEMENT IN POWDER, LIQUID OR ANY OTHER FORM (U.S. CLS. 6, 18, 44, 46, 51 AND 52).

FIRST USE 4-8-2011; IN COMMERCE 9-13-2011.

CLASS 5—(Continued).

4,119,660. R & D LIFESCIENCES, MENOMONIE, WI. SN 85-308,635. PUB. 9-13-2011, FILED 4-29-2011.

DIGESTAMACE

THE MARK CONSISTS OF STANDARD CHARACTERS WITHOUT CLAIM TO ANY PARTICULAR FONT, STYLE, SIZE, OR COLOR.

FOR NON-MEDICATED ADDITIVE FOR ANIMAL FEED FOR USE AS NUTRITIONAL SUPPLEMENTS IN POWDER, LIQUID OR ANY OTHER FORM (U.S. CLS. 6, 18, 44, 46, 51 AND 52).

FIRST USE 4-8-2011; IN COMMERCE 8-23-2011.

4,119,703. ARNOLD NUTRITION MANAGEMENT GROUP, LLC, HOLLYWOOD, FL. SN 85-346,189. PUB. 11-1-2011, FILED 6-14-2011.

VIVAMIL

THE MARK CONSISTS OF STANDARD CHARACTERS WITHOUT CLAIM TO ANY PARTICULAR FONT, STYLE, SIZE, OR COLOR.

FOR PHARMACEUTICAL PREPARATIONS, NAMELY, NUTRITIONAL DIETARY SUPPLEMENTS (U.S. CLS. 6, 18, 44, 46, 51 AND 52).

FIRST USE 1-1-2011; IN COMMERCE 5-1-2011.

4,119,724. HUNGRY FISH MEDIA LLC, CAMBRIDGE, MA. SN 85-976,211. PUB. 11-2-2010, FILED 5-27-2010.

PEAK LIFE

THE MARK CONSISTS OF STANDARD CHARACTERS WITHOUT CLAIM TO ANY PARTICULAR FONT, STYLE, SIZE, OR COLOR.

FOR DIETARY SUPPLEMENTS CONTAINING OMEGA 3; DIETARY SUPPLEMENTS IN THE NATURE OF OMEGA 3 FISH OIL CAPSULES; DIETARY SUPPLEMENTS; NUTRITIONAL SUPPLEMENTS; VITAMIN SUPPLEMENTS; MINERAL SUPPLEMENTS; DIETARY AND NUTRITIONAL SUPPLEMENTS; VITAMIN AND MINERAL SUPPLEMENTS; FOOD SUPPLEMENTS (U.S. CLS. 6, 18, 44, 46, 51 AND 52).

FIRST USE 9-0-2010; IN COMMERCE 9-0-2010.

CLASS 5—(Continued).

4,119,733. KAREN ROBERTS, SOUTHWICK, MA. SN 85-976,263. PUB. 6-21-2011, FILED 1-27-2011.



NO CLAIM IS MADE TO THE EXCLUSIVE RIGHT TO USE "EQUINE", APART FROM THE MARK AS SHOWN.

THE NAME "KAREN ROBERTS" IDENTIFIES A LIVING INDIVIDUAL WHOSE CONSENT IS OF RECORD.

THE MARK CONSISTS OF A HORSE'S HEAD, NECK, AND MANE, WHEREIN THE MANE OF THE HORSE IS DEPICTED AS A BACKWARDS, STYLIZED "K", AND A FRONT SIDE OF THE NECK IS DEPICTED AS A STYLIZED "R". UNDERNEATH THE HORSE DESIGN ARE THE STYLIZED WORDS "KAREN ROBERTS" CENTRALLY PLACED ABOVE THE STYLIZED WORD "EQUINE", WHICH IS CENTRALLY PLACED ABOVE THE STYLIZED WORDS "FOR THE HORSE OF DISTINCTION". THE WORD "EQUINE" IS PRECEDED BY A STREAKED SEGMENT WHICH TAPERS OUTWARDLY AS READ FROM LEFT TO RIGHT, AND IS SUCCEEDED BY A STREAKED SEGMENT WHICH TAPERS INWARDLY AS READ FROM LEFT TO RIGHT.

FOR INSECT REPELLENTS; NON-MEDICATED GROOMING PREPARATIONS FOR HORSES, NAMELY, LINIMENTS (U.S. CLS. 6, 18, 44, 46, 51 AND 52).

FIRST USE 5-1-2011; IN COMMERCE 5-1-2011.

CLASS 6—METAL GOODS

4,118,763. COLUMBIA ELEVATOR PRODUCTS CO., INC., BRIDGEPORT, CT. SN 76-704,312. PUB. 7-12-2011, FILED 8-31-2010.

QUIKDOOR

THE MARK CONSISTS OF STANDARD CHARACTERS WITHOUT CLAIM TO ANY PARTICULAR FONT, STYLE, SIZE, OR COLOR.

FOR REPLACEMENT DOOR PANELS FOR EXISTING ELEVATORS (U.S. CLS. 2, 12, 13, 14, 23, 25 AND 50).

FIRST USE 9-1-2011; IN COMMERCE 9-1-2011.

CLASS 6—(Continued).

4,118,858. NEWELL OPERATING COMPANY, ATLANTA, GA. SN 77-504,065. PUB. 5-5-2009, FILED 6-20-2008.

CONRAD

THE MARK CONSISTS OF STANDARD CHARACTERS WITHOUT CLAIM TO ANY PARTICULAR FONT, STYLE, SIZE, OR COLOR.

FOR CABINET HARDWARE, MADE WHOLLY OR IN PRIMARY PART OF METAL, NAMELY, CABINET DOOR KNOBS, CABINET DOOR PULLS, CABINET DRAWER KNOBS AND CABINET DRAWER PULLS (U.S. CLS. 2, 12, 13, 14, 23, 25 AND 50).

FIRST USE 4-7-2008; IN COMMERCE 4-7-2008.

4,118,919. METAL ROOF INNOVATIONS, LTD., COLORADO SPRINGS, CO. SN 77-751,522. PUB. 11-10-2009, FILED 6-3-2009.

S5

THE MARK CONSISTS OF STANDARD CHARACTERS WITHOUT CLAIM TO ANY PARTICULAR FONT, STYLE, SIZE, OR COLOR.

FOR METAL HARDWARE AND ACCESSORIES FOR MOUNTING TO METAL ROOFING AND SIDING, NAMELY, METAL STANDING SEAM ROOF CLAMPS, FACE-ATTACHED METAL MOUNTING BRACKETS, CROSS-MEMBERS, POSTS, RAILS, RODS, AND CLIPS FOR SNOW RETAINERS, AND PHOTOVOLTAIC AND SOLAR-THERMAL METAL ATTACHMENT BRACKETS (U.S. CLS. 2, 12, 13, 14, 23, 25 AND 50).

FIRST USE 1-12-2012; IN COMMERCE 1-12-2012.

4,119,222. WENGER CORPORATION, OWATONNA, MN. SN 85-103,302. PUB. 8-16-2011, FILED 8-9-2010.

SOUNDLOK

THE MARK CONSISTS OF STANDARD CHARACTERS WITHOUT CLAIM TO ANY PARTICULAR FONT, STYLE, SIZE, OR COLOR.

FOR METAL MODULAR SOUND-ISOLATING ROOM STRUCTURES FOR USE IN MUSICAL PERFORMANCE PRACTICING (U.S. CLS. 2, 12, 13, 14, 23, 25 AND 50).

FIRST USE 8-15-2011; IN COMMERCE 8-15-2011.

CLASS 6—(Continued).

4,119,267. SCAPE SIGNS, LTD., SCOTTSDALE, AZ. SN 85-133,233. PUB. 3-8-2011, FILED 9-20-2010.

SCAPE

THE MARK CONSISTS OF STANDARD CHARACTERS WITHOUT CLAIM TO ANY PARTICULAR FONT, STYLE, SIZE, OR COLOR.

FOR ADDRESS SIGNS OF METAL (U.S. CLS. 2, 12, 13, 14, 23, 25 AND 50).

FIRST USE 11-4-2010; IN COMMERCE 11-4-2010.

4,119,602. BAND-IT-IDEX, INC., DENVER, CO. SN 85-271,917. PUB. 8-2-2011, FILED 3-21-2011.

SHIELD-LOK

THE MARK CONSISTS OF STANDARD CHARACTERS WITHOUT CLAIM TO ANY PARTICULAR FONT, STYLE, SIZE, OR COLOR.

FOR BUCKLES OF COMMON METAL; CABLE CLAMPS OF METAL; METAL CLAMPS; METAL HOSE CLAMPS (U.S. CLS. 2, 12, 13, 14, 23, 25 AND 50).

FIRST USE 3-1-2011; IN COMMERCE 5-9-2011.

4,119,611. ZHEJIANG GOLEADER INDUSTRIES CO. LTD., PANAN CITY, CHINA. SN 85-278,146. PUB. 8-30-2011, FILED 3-28-2011.



OWNER OF U.S. REG. NOS. 3,550,403 AND 3,971,867. THE WORDING "GOLEADER" WITH THREE TEAR SHAPED LINES IN DECREASING SIZE FROM THE BOTTOM TO THE TOP.

FOR TRANSPORTABLE GREENHOUSES OF METAL FOR HOUSEHOLD USE; TRANSPORTABLE BUILDINGS OF METAL; TRELIS OF METAL; METAL GREENHOUSE FRAMES; METAL LADDERS; METAL PIPES AND TUBES; METAL DIVING BOARDS; METAL SWIMMING POOLS (U.S. CLS. 2, 12, 13, 14, 23, 25 AND 50).

FIRST USE 1-1-2011; IN COMMERCE 1-1-2011.

CLASS 7—MACHINERY

4,118,765. COLUMBIA ELEVATOR PRODUCTS CO., INC., BRIDGEPORT, CT. SN 76-704,489. PUB. 7-5-2011, FILED 9-15-2010.

XCHANGACAB

THE MARK CONSISTS OF STANDARD CHARACTERS WITHOUT CLAIM TO ANY PARTICULAR FONT, STYLE, SIZE, OR COLOR.

FOR PASSENGER ELEVATOR CABS AND DECORATIVE PANELS FOR SUCH ELEVATOR CABS (U.S. CLS. 13, 19, 21, 23, 31, 34 AND 35).

FIRST USE 10-1-2011; IN COMMERCE 10-1-2011.

4,118,811. EASTMAN KODAK COMPANY, ROCHESTER, NY. SN 77-380,615. PUB. 10-28-2008, FILED 1-25-2008.

SONORA

THE MARK CONSISTS OF STANDARD CHARACTERS WITHOUT CLAIM TO ANY PARTICULAR FONT, STYLE, SIZE, OR COLOR.

THE ENGLISH TRANSLATION OF THE WORD "SONORA" IN THE MARK IS SOUND.

FOR COMMERCIAL PRINTING PLATES (U.S. CLS. 13, 19, 21, 23, 31, 34 AND 35).

FIRST USE 12-1-2011; IN COMMERCE 12-1-2011.

4,118,886. SMART PRODUCT INNOVATIONS INC., JUNO BEACH, FL. SN 77-641,119. PUB. 5-26-2009, FILED 12-30-2008.

ECO-AUGER

THE MARK CONSISTS OF STANDARD CHARACTERS WITHOUT CLAIM TO ANY PARTICULAR FONT, STYLE, SIZE, OR COLOR.

FOR ENGINES NOT FOR LAND VEHICLES FOR GENERATING POWER; GENERATORS OF ELECTRICITY INCORPORATING AUGERS (U.S. CLS. 13, 19, 21, 23, 31, 34 AND 35).

FIRST USE 9-1-2009; IN COMMERCE 1-2-2010.

CLASS 7—(Continued).

4,118,916. CO2NEXUS, INC., DENVER, CO. SN 77-740,252. PUB. 9-29-2009, FILED 5-19-2009.



NO CLAIM IS MADE TO THE EXCLUSIVE RIGHT TO USE "INC", APART FROM THE MARK AS SHOWN.

THE MARK CONSISTS OF THE WORDING "CO2 NEXUS INC" AND DESIGNS. THE "2" IS A SUBSCRIPT OF "CO", SIGNIFYING CARBON DIOXIDE. THE WORDING "INC" APPEARS SMALLER AND JUST BELOW THE "S" IN "NEXUS". THE DESIGNS CONSIST OF TWO CRESCENT-LIKE SEMI-CIRCLES OF DIFFERENT SIZE. THE OUTER SEMI-CIRCLE OPENS UPWARD AND CONTAINS ALL OF THE WORDING AND THE OTHER SEMI-CIRCLE. THE SMALLER SEMI-CIRCLE OPENS DOWNWARD AND PARTIALLY CONTAINS THE WORD "NEXUS".

FOR COMMERCIAL DRY CLEANING MACHINES; COMMERCIAL LAUNDRY MACHINES COMBINING A CLOTHES WASHER WITH A CLOTHES DRYER (U.S. CLS. 13, 19, 21, 23, 31, 34 AND 35).

FIRST USE 7-15-2011; IN COMMERCE 7-15-2011.

4,119,051. EURO-PRO OPERATING LLC, NEWTON, MA. SN 77-982,900. PUB. 6-16-2009, FILED 4-14-2009.

NINJA

THE MARK CONSISTS OF STANDARD CHARACTERS WITHOUT CLAIM TO ANY PARTICULAR FONT, STYLE, SIZE, OR COLOR.

FOR ELECTRIC KITCHEN APPLIANCES FOR HOUSEHOLD USE, NAMELY, ELECTRIC MIXERS, ELECTRIC FOOD AND MEAT GRINDERS, ELECTRIC COFFEE GRINDERS, ELECTRIC JUICERS, ELECTRIC JUICE EXTRACTORS, ELECTRIC FRUIT PRESSES, ELECTRIC FRUIT PEELERS, ELECTRIC FOOD SLICERS, ELECTRIC EGG BEATERS, ELECTRIC WHISKS, ELECTRIC GRATERS, ELECTRIC VEGETABLE PEELERS, ELECTRIC PASTA MAKERS (U.S. CLS. 13, 19, 21, 23, 31, 34 AND 35).

FIRST USE 8-10-2011; IN COMMERCE 8-10-2011.

CLASS 7—(Continued).

4,119,130. CURTIS INDUSTRIES LLC, WORCESTER, MA. SN 85-053,419. PUB. 5-17-2011, FILED 6-3-2010.

SNO-PRO

THE MARK CONSISTS OF STANDARD CHARACTERS WITHOUT CLAIM TO ANY PARTICULAR FONT, STYLE, SIZE, OR COLOR.

OWNER OF U.S. REG. NO. 2,113,006.

FOR PLOWS FOR TRACTORS AND UTILITY VEHICLES; MECHANICAL SPREADERS (U.S. CLS. 13, 19, 21, 23, 31, 34 AND 35).

FIRST USE 12-31-2008; IN COMMERCE 12-31-2008.

4,119,144. MICROJET TECHNOLOGY CO., LTD, HSINCHU, TAIWAN. SN 85-058,359. PUB. 5-31-2011, FILED 6-9-2010.

CometrueJet

THE MARK CONSISTS OF STANDARD CHARACTERS WITHOUT CLAIM TO ANY PARTICULAR FONT, STYLE, SIZE, OR COLOR.

FOR PRINTING APPARATUS, NAMELY, INK-JET PRINTERS; INK-JET PRINT HEADS; PRINTING INK SUPPLY SYSTEMS FOR USE WITH PRINTER COMPOSED PRIMARILY OF INK RESERVOIRS, INK PUMPS AND INK CONNECTORS; STORAGE CONTAINERS FOR INK AND COLORED MEDIA, ADAPTED FOR USE IN PRINTING MACHINES SOLD EMPTY, AND PARTS THEREOF (U.S. CLS. 13, 19, 21, 23, 31, 34 AND 35).

FIRST USE 12-21-2011; IN COMMERCE 12-21-2011.

CLASS 7—(Continued).

4,119,147. MICROJET TECHNOLOGY CO., LTD, HSINCHU, TAIWAN. SN 85-058,426. PUB. 5-31-2011, FILED 6-9-2010.

CurieJet

THE MARK CONSISTS OF STANDARD CHARACTERS WITHOUT CLAIM TO ANY PARTICULAR FONT, STYLE, SIZE, OR COLOR.

FOR PRINTING MACHINES AND APPARATUS, NAMELY, INK-JET PRINTING MACHINES AND APPARATUS FOR USE ON MEDIA SUCH AS PAPERS, CIRCUIT BOARDS, DISPLAYS, GLASSES, CERAMICS, AND TEXTILES; PRINTING INK SUPPLY SYSTEMS FOR USE WITH PRINTERS COMPOSED PRIMARILY OF INK RESERVOIRS, INK PUMPS AND INK CONNECTORS; STORAGE CONTAINERS FOR INK AND COLORED MEDIA ADAPTED FOR USE IN PRINTING MACHINES SOLD EMPTY, AND PARTS THEREOF; PUMPS FOR MACHINES, NAMELY, GAS AND LIQUID PUMPS; COMPRESSORS FOR MACHINES, NAMELY, HIGH CAPACITY DIAPHRAGM COMPRESSORS; DIAPHRAGM DOSING PUMPS; DIAPHRAGM LIQUID PUMPS, VACUUM PUMPS, VACUUM APPARATUS, NAMELY, LABORATORY PUMPS FOR GAS AND LIQUIDS, AND VACUUM INSTALLATIONS COMPRISED OF VACUUM PUMPS AND VACUUM APPARATUS, NAMELY, MULTI-USER LABORATORY VACUUM PUMP SYSTEMS; VACUUM INSTALLATIONS COMPRISED OF RECEPTACLES, HIGH EFFICIENCY CONDENSATORS, VACUUM PUMPS, VACUUM EXTRACTION DEVICES, NAMELY, LABORATORY VACUUM PUMP SYSTEMS, CONNECTING LINES AND RELATED MECHANICAL AND ELECTRONIC VACUUM REGULATORS; VACUUM EQUIPMENT, CONSISTING OF TANKS, HIGH-PERFORMANCE CONDENSERS, VACUUM PUMPS, VACUUM POINTS OF USE, NAMELY, CONNECTOR PIPES AS WELL AS THE MECHANICAL AND ELECTRONIC VACUUM REGULATORS APPERTAINING THERETO (U.S. CLS. 13, 19, 21, 23, 31, 34 AND 35).

FIRST USE 12-21-2011; IN COMMERCE 12-21-2011.

4,119,162. HONDA MOTOR CO., LTD., MINATO-KU, TOKYO, JAPAN. SN 85-067,818. PUB. 5-10-2011, FILED 6-21-2010.

EU3000i

THE MARK CONSISTS OF STANDARD CHARACTERS WITHOUT CLAIM TO ANY PARTICULAR FONT, STYLE, SIZE, OR COLOR.

FOR GENERATORS FOR LAND VEHICLES; PORTABLE ELECTRIC GENERATORS; AC GENERATORS; DC GENERATORS; PORTABLE GAS OPERATED POWER GENERATORS, NAMELY, GENERATORS FOR CAMPING, TAILGATING, AND BASIC HOME BACKUP POWER (U.S. CLS. 13, 19, 21, 23, 31, 34 AND 35).

FIRST USE 6-0-2001; IN COMMERCE 6-0-2001.

CLASS 7—(Continued).

4,119,204. FIBERIO TECHNOLOGY CORPORATION, MCALLEN, TX. SN 85-090,792. PUB. 7-19-2011, FILED 7-22-2010.

THE FORCE FOR NANOFIBERS

THE MARK CONSISTS OF STANDARD CHARACTERS WITHOUT CLAIM TO ANY PARTICULAR FONT, STYLE, SIZE, OR COLOR.

NO CLAIM IS MADE TO THE EXCLUSIVE RIGHT TO USE "NANOFIBERS", APART FROM THE MARK AS SHOWN.

FOR CENTRIFUGAL FIBER MANUFACTURING MACHINES AND STRUCTURAL PARTS THEREFORE, NAMELY, CENTRIFUGAL FIBER PROCESSING CHAMBERS, FIBER COLLECTORS, NOZZLES USED WITH EQUIPMENT TO MAKE FIBERS, NEEDLES USED WITH EQUIPMENT TO MAKE FIBERS, SPINNERETS USED WITH EQUIPMENT TO MAKE FIBERS, NEEDLE HOLDERS USED WITH EQUIPMENT TO MAKE FIBERS, NOZZLE AND NEEDLE HOLDER SETS USED WITH EQUIPMENT TO MAKE FIBERS, AND HEATING ELEMENTS BEING MACHINE PARTS USED WITH EQUIPMENT TO MAKE FIBERS (U.S. CLS. 13, 19, 21, 23, 31, 34 AND 35).

FIRST USE 1-1-2011; IN COMMERCE 1-1-2011.

4,119,205. FIBERIO TECHNOLOGY CORPORATION, MCALLEN, TX. SN 85-090,798. PUB. 8-2-2011, FILED 7-22-2010.

FIBERIO

THE MARK CONSISTS OF STANDARD CHARACTERS WITHOUT CLAIM TO ANY PARTICULAR FONT, STYLE, SIZE, OR COLOR.

FOR CENTRIFUGAL FIBER MANUFACTURING MACHINES AND STRUCTURAL PARTS THEREFORE, NAMELY, CENTRIFUGAL FIBER PROCESSING CHAMBERS, FIBER COLLECTORS, NOZZLES USED WITH EQUIPMENT TO MAKE FIBERS, NEEDLES USED WITH EQUIPMENT TO MAKE FIBERS, SPINNERETS USED WITH EQUIPMENT TO MAKE FIBERS, NEEDLE HOLDERS USED WITH EQUIPMENT TO MAKE FIBERS, NOZZLE AND NEEDLE HOLDER SETS USED WITH EQUIPMENT TO MAKE FIBERS, AND HEATING ELEMENTS BEING MACHINE PARTS USED WITH EQUIPMENT TO MAKE FIBERS (U.S. CLS. 13, 19, 21, 23, 31, 34 AND 35).

FIRST USE 1-1-2011; IN COMMERCE 1-1-2011.

CLASS 7—(Continued).

4,119,288. LAKE ERIE PORTABLE SCREENERS, INC., ERIE, PA. SN 85-149,169. PUB. 5-24-2011, FILED 10-10-2010.



NO CLAIM IS MADE TO THE EXCLUSIVE RIGHT TO USE "USA", APART FROM THE MARK AS SHOWN.

THE COLOR(S) GRAY, RED, WHITE, BLUE, DARK BLUE, BROWN AND, YELLOW IS/ARE CLAIMED AS A FEATURE OF THE MARK.

THE MARK CONSISTS OF A LONG OBLONG SHAPE BISECTED WITH A LARGER CIRCULAR AREA IN THE MIDDLE WITH THE GRAY SHADING BEING LIGHTER TOWARD THE TOP AND DARKER TOWARD THE BOTTOM; THE CIRCULAR GRAYISH AND WHITE AREA CONTAINS A BROWN PITBULL DOG BREAKING THROUGH THE CIRCLE; THE DOG HAS A RED COLLAR WITH WHITE SPIKES AND A RED TONGUE; THE DOG IS SNARLING AND IS HOLDING A RED, WHITE AND BLUE US FLAG ON A YELLOW POLE AND IS WEARING DOG TAGS WITH "USA" ON THEM, THE "U" IS RED, THE "S" IS WHITE AND THE "A" IS BLUE; THE BACKGROUND BEHIND THE DOG IS DARK BLUE WITH A YELLOW LIGHTNING BOLT; GRAY SHARDS OF THE BROKEN-THROUGH AREA ARE VISIBLE AROUND THE DOG; THE LITERAL ELEMENT "PIT" IN COLOR GRAY IS IN THE OBLONG AREA TO THE LEFT OF THE CIRCULAR AREA; THE LITERAL ELEMENT "BULL" IN COLOR GRAY IS TO THE RIGHT OF THE CIRCULAR AREA IN THE OBLONG AREA; THE LITERAL ELEMENT "PITBULL" IS SHADED DARKER GRAY TOWARD THE TOP AND LIGHTER GRAY TOWARD THE BOTTOM AND HAS GRAY SHADING TO THE RIGHT OF THE LETTERS.

FOR GRAVEL AND DIRT SORTING AND SCREENING MACHINES (U.S. CLS. 13, 19, 21, 23, 31, 34 AND 35). FIRST USE 8-31-2010; IN COMMERCE 6-2-2011.

4,119,343. TORINO, KENNETH, COLCHESTER, VT. SN 85-184,357. PUB. 4-12-2011, FILED 11-24-2010.

K-TOR

THE MARK CONSISTS OF STANDARD CHARACTERS WITHOUT CLAIM TO ANY PARTICULAR FONT, STYLE, SIZE, OR COLOR.

FOR PORTABLE ELECTRIC POWER GENERATORS (U.S. CLS. 13, 19, 21, 23, 31, 34 AND 35).

FIRST USE 2-28-2011; IN COMMERCE 2-28-2011.

CLASS 7—(Continued).

4,119,348. GARDUS, INC., POWAY, CA. SN 85-185,392. PUB. 5-24-2011, FILED 11-26-2010.

VERTALOK

THE MARK CONSISTS OF STANDARD CHARACTERS WITHOUT CLAIM TO ANY PARTICULAR FONT, STYLE, SIZE, OR COLOR.

FOR POWER TOOL PARTS, NAMELY, GUTTER CLEANING ATTACHMENTS, ROTARY WALL SANDING ATTACHMENTS, ROTARY WASHING AND BUFFING ATTACHMENTS (U.S. CLS. 13, 19, 21, 23, 31, 34 AND 35).

FIRST USE 8-10-2011; IN COMMERCE 8-10-2011.

4,119,691. TIFCO INDUSTRIES, INC., CYPRESS, TX. SN 85-331,784. PUB. 10-18-2011, FILED 5-26-2011.

INFERNO

THE MARK CONSISTS OF STANDARD CHARACTERS WITHOUT CLAIM TO ANY PARTICULAR FONT, STYLE, SIZE, OR COLOR.

FOR ABRASIVE PRODUCTS, NAMELY, DISCS USED ON POWER TOOLS FOR CUTTING, GRINDING, AND/OR FINISHING (U.S. CLS. 13, 19, 21, 23, 31, 34 AND 35).

FIRST USE 1-4-2011; IN COMMERCE 1-4-2011.

CLASS 8—HAND TOOLS

4,119,114. RONALD ROBERTS, EAGLEVILLE, PA. SN 85-044,794. PUB. 3-22-2011, FILED 5-21-2010.

Shovelever

THE MARK CONSISTS OF STANDARD CHARACTERS WITHOUT CLAIM TO ANY PARTICULAR FONT, STYLE, SIZE, OR COLOR.

FOR HAND TOOLS, NAMELY, A DEVICE TO AID THE SHOVELING PROCESS IN THE NATURE OF A LEVER ATTACHED TO A PERSON'S UPPER LEG ON WHICH A SHOVEL HANDLE CAN REST (U.S. CLS. 23, 28 AND 44).

FIRST USE 1-11-2012; IN COMMERCE 1-11-2012.

CLASS 8—(Continued).

4,119,325. AMES TRUE TEMPER, INC., CAMP HILL, PA. SN 85-176,648. PUB. 10-18-2011, FILED 11-15-2010.

ScoopBoss

THE MARK CONSISTS OF STANDARD CHARACTERS WITHOUT CLAIM TO ANY PARTICULAR FONT, STYLE, SIZE, OR COLOR.

FOR MANUALLY OPERATED LAWN AND GARDEN HAND TOOLS, NAMELY, SCOOPS (U.S. CLS. 23, 28 AND 44).

FIRST USE 11-0-2011; IN COMMERCE 11-0-2011.

CLASS 9—ELECTRICAL AND SCIENTIFIC APPARATUS

4,118,756. THE TAYLOR GROUP, INC., LOUISVILLE, MS. SN 76-698,058. PUB. 10-20-2009, FILED 6-24-2009.

VISION PLUS

THE MARK CONSISTS OF STANDARD CHARACTERS WITHOUT CLAIM TO ANY PARTICULAR FONT, STYLE, SIZE, OR COLOR.

FOR PEDESTRIAN WARNING SYSTEM COMPRISING CAMERAS AND VIDEO-BASED PATTERN RECOGNITION EQUIPMENT COMPOSED OF COMPUTER CHIPS, COMPUTER HARDWARE, AND COMPUTER SOFTWARE, ALL FOR DETECTING THE PRESENCE OF PEDESTRIANS AROUND A POWERED INDUSTRIAL VEHICLE AND PROVIDING A WARNING TO AN OPERATOR OF THE VEHICLE (U.S. CLS. 21, 23, 26, 36 AND 38).

FIRST USE 3-29-2011; IN COMMERCE 3-29-2011.

4,118,774. UNIVERSAL LIGHTING TECHNOLOGIES, INC., NASHVILLE, TN. SN 76-706,993. PUB. 7-19-2011, FILED 3-29-2011.

EVERLINE

THE MARK CONSISTS OF STANDARD CHARACTERS WITHOUT CLAIM TO ANY PARTICULAR FONT, STYLE, SIZE, OR COLOR.

FOR LED LAMPS, LED CONTROLLERS, LED BALLASTS, AND LED MODULE (U.S. CLS. 21, 23, 26, 36 AND 38).

FIRST USE 12-22-2011; IN COMMERCE 12-22-2011.

CLASS 9—(Continued).

4,118,781. DIRECT HOLDINGS AMERICAS INC., FAIRFAX, VA. SN 77-137,374. PUB. 4-15-2008, FILED 3-22-2007.

CLASS 9—(Continued).

4,118,790. RICARDO ARJONA, NEW YORK, NY. SN 77-247,093. PUB. 6-3-2008, FILED 8-3-2007.

STARVISTA

THE MARK CONSISTS OF STANDARD CHARACTERS WITHOUT CLAIM TO ANY PARTICULAR FONT, STYLE, SIZE, OR COLOR.

FOR AUDIO CDS AND RECORDINGS IN THE FIELDS OF MUSIC; DVDS FEATURING TELEVISION PROGRAMS, DOCUMENTARIES; VIDEO RECORDINGS FEATURING TELEVISION PROGRAMS AND DOCUMENTARIES (U.S. CLS. 21, 23, 26, 36 AND 38).
FIRST USE 1-3-2012; IN COMMERCE 1-3-2012.

RICARDO ARJONA

THE MARK CONSISTS OF STANDARD CHARACTERS WITHOUT CLAIM TO ANY PARTICULAR FONT, STYLE, SIZE, OR COLOR.

FOR MUSICAL SOUND RECORDINGS; AUDIO-VISUAL RECORDINGS, NAMELY, COMPACT DISCS, AUDIO DISCS, CD-ROMS, VIDEO DISCS, DVDS, DATS, MP3S, AND LASER DISCS, ALL FEATURING MUSIC, SOUND TRACKS; DOWNLOADABLE RING TONES, MUSIC AND GRAPHICS VIA THE INTERNET AND WIRELESS DEVICES; DOWNLOADABLE WIRELESS ENTERTAINMENT, NAMELY, RING TONES, SCREEN SAVERS AND IMAGES, AND WALLPAPER; DOWNLOADABLE MUSICAL SOUND RECORDINGS; DOWNLOADABLE VIDEO RECORDINGS FEATURING MUSIC (U.S. CLS. 21, 23, 26, 36 AND 38).
FIRST USE 0-0-1993; IN COMMERCE 0-0-1993.

4,118,782. PCT INTERNATIONAL, INC., MESA, AZ. SN 77-144,888. PUB. 10-21-2008, FILED 3-30-2007.

INNOVATION FOR THE LAST MILE

THE MARK CONSISTS OF STANDARD CHARACTERS WITHOUT CLAIM TO ANY PARTICULAR FONT, STYLE, SIZE, OR COLOR.

NO CLAIM IS MADE TO THE EXCLUSIVE RIGHT TO USE "LAST MILE", APART FROM THE MARK AS SHOWN. FOR TELEVISION AND SATELLITE RECEPTION PRODUCTS AND ACCESSORIES, NAMELY, AMPLIFIERS, CABLE FOR TRANSMISSION OF TELEVISION AND SATELLITE SIGNALS, COAXIAL CABLE, CABLE CONNECTORS, AUDIO/VIDEO CONNECTORS, CONNECTION CABLES (U.S. CLS. 21, 23, 26, 36 AND 38).
FIRST USE 1-25-2010; IN COMMERCE 2-26-2010.

4,118,791. CARTER, MERCEDES LYNN ANTIONETTE, LAS VEGAS, NV. SN 77-252,312. PUB. 2-12-2008, FILED 8-10-2007.

4,118,789. SOFTPRO GMBH, BOEBLINGEN, FED REP GERMANY. SN 77-233,404. PUB. 1-19-2010, FILED 7-19-2007.

SIGNPAD

THE MARK CONSISTS OF STANDARD CHARACTERS WITHOUT CLAIM TO ANY PARTICULAR FONT, STYLE, SIZE, OR COLOR.

FOR DEVICES AND CORRESPONDING COMPUTER SOFTWARE FOR ELECTRONIC CAPTURING AND ADMINISTRATION OF USER INPUT, NAMELY, SIGNATURES AND BIOMETRIC DATA; ELECTRONIC PENS FOR SCREEN DEVICES AS WELL AS PARTS THEREOF (U.S. CLS. 21, 23, 26, 36 AND 38).
FIRST USE 12-31-2007; IN COMMERCE 12-31-2007.



THE NAME(S), PORTRAIT(S), AND/OR SIGNATURE(S) SHOWN IN THE MARK DOES NOT IDENTIFY A PARTICULAR LIVING INDIVIDUAL.

THE MARK CONSISTS OF THE LETTERS "PATIENCE RYZIN" IN STYLIZED FORM.
FOR MUSICAL SOUND RECORDINGS (U.S. CLS. 21, 23, 26, 36 AND 38).
FIRST USE 4-20-2007; IN COMMERCE 1-20-2010.

CLASS 9—(Continued).

4,118,802. COGNEX CORPORATION, NATICK, MA. SN 77-343,514. PUB. 11-24-2009, FILED 12-4-2007.

Cognex VSoC

THE MARK CONSISTS OF STANDARD CHARACTERS WITHOUT CLAIM TO ANY PARTICULAR FONT, STYLE, SIZE, OR COLOR.

OWNER OF U.S. REG. NOS. 1,390,557 AND 1,451,957. NO CLAIM IS MADE TO THE EXCLUSIVE RIGHT TO USE "VSO C", APART FROM THE MARK AS SHOWN.

FOR IMAGE SENSOR FOR MACHINE VISION APPLICATIONS FOR USE IN MANUFACTURING, INDUSTRIAL, ENGINEERING, FACTORY AND LOGISTICAL APPLICATIONS (U.S. CLS. 21, 23, 26, 36 AND 38).

FIRST USE 12-26-2010; IN COMMERCE 12-26-2010.

4,118,808. FONEGEAR, LLC, ROCHESTER HILLS, MI. SN 77-363,583. PUB. 11-25-2008, FILED 1-3-2008.

iXercise

THE MARK CONSISTS OF THE TERM "IXERCISE" WITH A STICK FIGURE DESIGN USED TO MAKE THE LETTER "X".

FOR CASES FOR PORTABLE ELECTRONIC DEVICES IN THE NATURE OF MP3 PLAYERS AND PERSONAL MEDIA PLAYERS (U.S. CLS. 21, 23, 26, 36 AND 38).

FIRST USE 7-0-2011; IN COMMERCE 7-0-2011.

4,118,817. EARL RENNISON, MENLO PARK, CA. SN 77-404,330. PUB. 10-21-2008, FILED 2-22-2008.

GeneBean

THE MARK CONSISTS OF STANDARD CHARACTERS WITHOUT CLAIM TO ANY PARTICULAR FONT, STYLE, SIZE, OR COLOR.

FOR COMPUTER SOFTWARE FOR SCIENTIFIC ANALYSIS OF GENETIC SEQUENCES (U.S. CLS. 21, 23, 26, 36 AND 38).

FIRST USE 1-11-2012; IN COMMERCE 1-11-2012.

CLASS 9—(Continued).

4,118,818. SILVER OAKS PUBLISHING, INC., MOLINE, IL. SN 77-421,821. PUB. 8-12-2008, FILED 3-14-2008.



THE MARK CONSISTS OF A FIGURE WITH A SUBSTANTIALLY SQUARE-SHAPED FACE HAVING TWO EYES WHICH ARE EACH SUBSTANTIALLY OVAL IN SHAPE. ONE EYE IS SLIGHTLY LARGER THAN THE OTHER AND IS LOCATED SLIGHTLY HIGHER WITH RESPECT TO THE SMALLER EYE WITHIN THE SQUARE SHAPE. A U-SHAPED SMILE, WITH A SERIF AT THE END ADJACENT THE LARGER EYE IS ALSO LOCATED WITHIN THE SQUARE SHAPE BELOW BOTH OF THE EYES. AN ARM EXTENDS FROM THE LATERAL EDGES OF THE SQUARE. EACH ARM INCLUDES A HAND AT THE END OPPOSITE THE SQUARE. EACH HAND INCLUDES FOUR DIGITS. TWO LEGS EXTEND FROM THE LOWER HORIZONTAL EDGE OF THE SQUARE. EACH LEG TERMINATES IN A DIGITLESS FOOT.

FOR COMPUTER GAME PROGRAM, NAMELY, A COMPUTER MEMORY GAME USING CUSTOM PICTURES (U.S. CLS. 21, 23, 26, 36 AND 38).

FIRST USE 6-17-2011; IN COMMERCE 6-17-2011.

4,118,820. AB INITIO SOFTWARE LLC, LEXINGTON, MA. SN 77-436,116. PUB. 3-17-2009, FILED 3-31-2008.

EMMS

THE MARK CONSISTS OF STANDARD CHARACTERS WITHOUT CLAIM TO ANY PARTICULAR FONT, STYLE, SIZE, OR COLOR.

FOR DOWNLOADABLE COMPUTER SOFTWARE FOR THE MANAGEMENT, MAINTENANCE AND ADMINISTRATION OF ENTERPRISE DATA STORES USED IN OR RESULTING FROM PROCESSING OF DATA, NAMELY, SOFTWARE FOR USE WITH DATA WAREHOUSING, BILLING SYSTEMS AND TRANSACTION SYSTEMS, AND NOT FOR USE WITH BUSINESS MARKETING APPLICATIONS (U.S. CLS. 21, 23, 26, 36 AND 38).

FIRST USE 5-12-2011; IN COMMERCE 5-12-2011.

CLASS 9—(Continued).

4,118,821. AERIELLE IP HOLDINGS, LLC, CINCINNATI, OH. SN 77-437,230. PUB. 8-26-2008, FILED 4-1-2008.

CONNECT. STREAM. LISTEN

THE MARK CONSISTS OF STANDARD CHARACTERS WITHOUT CLAIM TO ANY PARTICULAR FONT, STYLE, SIZE, OR COLOR.

NO CLAIM IS MADE TO THE EXCLUSIVE RIGHT TO USE "STREAM", APART FROM THE MARK AS SHOWN.

FOR ELECTRONIC DIGITAL MEDIA TRANSMITTER AND RECEIVER DEVICE FOR TRANSFERRING ANALOG OR DIGITAL CONTENT FROM AN MP3 OR MP4 PLAYER OR ANY PORTABLE OR NON-PORTABLE MEDIA DEVICE TO ANOTHER ELECTRONIC DIGITAL MEDIA TRANSMITTER AND RECEIVER DEVICE (U.S. CLS. 21, 23, 26, 36 AND 38).

FIRST USE 6-0-2009; IN COMMERCE 2-0-2011.

4,118,823. INTERNATIONAL BUSINESS MACHINES CORPORATION, AKA IBM CORPORATION, ARMONK, NY. SN 77-440,513. PUB. 11-4-2008, FILED 4-4-2008.

S-TAP

THE MARK CONSISTS OF STANDARD CHARACTERS WITHOUT CLAIM TO ANY PARTICULAR FONT, STYLE, SIZE, OR COLOR.

FOR COMPUTER SOFTWARE FOR USE IN CONNECTION WITH DATABASE SECURITY, PROTECTION OF PROPRIETARY INFORMATION, AND DATA MANAGEMENT (U.S. CLS. 21, 23, 26, 36 AND 38).

FIRST USE 3-3-2005; IN COMMERCE 3-3-2005.

4,118,830. NIXON, INC., ENCINITAS, CA. SN 77-465,284. PUB. 3-24-2009, FILED 5-4-2008.

NIXON 

THE MARK CONSISTS OF A STYLIZED TEARDROP TO THE RIGHT OF THE TERM "NIXON".

FOR MOBILE TELEPHONE COVERS, CASES; HEADPHONES; AUDIO SPEAKERS (U.S. CLS. 21, 23, 26, 36 AND 38).

FIRST USE 12-31-2008; IN COMMERCE 12-31-2008.

CLASS 9—(Continued).

4,118,842. THE DATA CENTER, INC., YADKINVILLE, NC. SN 77-491,359. PUB. 11-4-2008, FILED 6-5-2008.

2ENCLUDE

THE MARK CONSISTS OF STANDARD CHARACTERS WITHOUT CLAIM TO ANY PARTICULAR FONT, STYLE, SIZE, OR COLOR.

FOR COMPUTER SOFTWARE FOR THE TELECOMMUNICATIONS INDUSTRY, NAMELY, CUSTOMER SERVICES MANAGEMENT (U.S. CLS. 21, 23, 26, 36 AND 38).

FIRST USE 12-12-2011; IN COMMERCE 12-12-2011.

4,118,861. LAWING, ANDREW SCOTT, NEWARK, DE. SN 77-514,824. PUB. 12-9-2008, FILED 7-3-2008.

Zexcoil

THE MARK CONSISTS OF STANDARD CHARACTERS WITHOUT CLAIM TO ANY PARTICULAR FONT, STYLE, SIZE, OR COLOR.

FOR ELECTRICAL PICKUPS FOR USE WITH MUSICAL INSTRUMENTS; ELECTRONIC SOUND PICKUP FOR GUITARS (U.S. CLS. 21, 23, 26, 36 AND 38).

FIRST USE 6-27-2011; IN COMMERCE 6-27-2011.

4,118,865. SARYAN CORPORATION, CHICAGO, IL. SN 77-542,183. PUB. 12-30-2008, FILED 8-8-2008.



THE MARK CONSISTS OF CONCENTRIC CIRCLES OVERLAPPING A SPIRALING COIL.

FOR DIGITAL MEDIA, NAMELY, DIGITAL VIDEO DISCS, DIGITAL VERSATILE DISCS, DVDS, CDS FEATURING THEATRICAL AND MUSICAL PERFORMANCES (U.S. CLS. 21, 23, 26, 36 AND 38).

FIRST USE 6-10-2010; IN COMMERCE 6-10-2010.

CLASS 9—(Continued).

4,118,868. SAMSUNG ELECTRONICS CO., LTD., SUWON-SI, GYEONGGI-DO, REPUBLIC OF KOREA. SN 77-551,902. PUB. 12-9-2008, FILED 8-20-2008.

REPP

THE MARK CONSISTS OF STANDARD CHARACTERS WITHOUT CLAIM TO ANY PARTICULAR FONT, STYLE, SIZE, OR COLOR.

FOR MOBILE PHONES (U.S. CLS. 21, 23, 26, 36 AND 38).
FIRST USE 12-1-2011; IN COMMERCE 12-1-2011.

4,118,871. NYKO TECHNOLOGIES, INC., LOS ANGELES, CA. SN 77-562,821. PUB. 5-24-2011, FILED 9-4-2008.

TRANS-PORT

THE MARK CONSISTS OF STANDARD CHARACTERS WITHOUT CLAIM TO ANY PARTICULAR FONT, STYLE, SIZE, OR COLOR.

FOR VIDEO GAME CONTROLLER ACCESSORIES, NAMELY, ELECTRICAL CONNECTORS FOR INTERFACING ELECTRONIC CIRCUITS IN VIDEO GAME CONTROLLERS WITH ATTACHMENTS, NAMELY, GUN GRIPS, TYPE PADS, DRIVING WHEELS, MUSICAL INSTRUMENT-SHAPED DEVICES, AND OTHER VIDEO GAME CONTROLLERS (U.S. CLS. 21, 23, 26, 36 AND 38).
FIRST USE 9-14-2008; IN COMMERCE 4-21-2009.

4,118,879. GLOBAL MARKETING RESOURCES, INC., DUNEDIN, FL. SN 77-615,864. PUB. 3-31-2009, FILED 11-17-2008.

HUMICON

THE MARK CONSISTS OF STANDARD CHARACTERS WITHOUT CLAIM TO ANY PARTICULAR FONT, STYLE, SIZE, OR COLOR.

FOR DOWNLOADABLE INTERNET-BASED ICONS AND ANIMATED ICONS FOR USE IN PERSONALIZING THE CONTENT OF E-MAIL AND INSTANT MESSAGE COMMUNICATIONS (U.S. CLS. 21, 23, 26, 36 AND 38).
FIRST USE 12-2-2011; IN COMMERCE 12-2-2011.

CLASS 9—(Continued).

4,118,883. LEVERETT, DANIELLE, ATLANTA, GA. AND BROWN, SUSAN, ATLANTA, GA. SN 77-629,512. PUB. 4-14-2009, FILED 12-9-2008.

THE JANEDEAR GIRLS

THE MARK CONSISTS OF STANDARD CHARACTERS WITHOUT CLAIM TO ANY PARTICULAR FONT, STYLE, SIZE, OR COLOR.

NO CLAIM IS MADE TO THE EXCLUSIVE RIGHT TO USE "GIRLS", APART FROM THE MARK AS SHOWN. THE NAME "JANEDEAR" DOES NOT IDENTIFY A LIVING INDIVIDUAL.

FOR SERIES OF MUSICAL SOUND RECORDINGS AND AUDIOVISUAL RECORDINGS FEATURING MUSIC AND ENTERTAINMENT (U.S. CLS. 21, 23, 26, 36 AND 38).

FIRST USE 4-26-2010; IN COMMERCE 4-26-2010.

4,118,890. CLINICAL INK, INC., WINSTON-SALEM, NC. SN 77-645,361. PUB. 4-28-2009, FILED 1-8-2009.

KEEP THE PEN, NOT THE PAPER.

THE MARK CONSISTS OF STANDARD CHARACTERS WITHOUT CLAIM TO ANY PARTICULAR FONT, STYLE, SIZE, OR COLOR.

FOR COMPUTER SOFTWARE FOR USE IN CREATING PAPER CLINICAL TRIAL SOURCE DOCUMENTS AS SECURE DIGITAL DATA FORMS CONTAINING DATA ENTRY, DATA VALIDATION RULES, ELECTRONIC SIGNATURE CAPTURE AND DATA TRANSMISSION FEATURES FOR USE IN CLINICAL RESEARCH STUDIES (U.S. CLS. 21, 23, 26, 36 AND 38).
FIRST USE 8-9-2011; IN COMMERCE 8-9-2011.

4,118,897. BETHESDA SOFTWARES LLC, ROCKVILLE, MD. SN 77-663,852. PUB. 6-2-2009, FILED 2-5-2009.

FALLOUT

THE MARK CONSISTS OF STANDARD CHARACTERS WITHOUT CLAIM TO ANY PARTICULAR FONT, STYLE, SIZE, OR COLOR.

OWNER OF U.S. REG. NO. 2,181,084.
FOR MOTION PICTURE FILMS ABOUT A POST-NUCLEAR APOCALYPTIC WORLD (U.S. CLS. 21, 23, 26, 36 AND 38).

FIRST USE 10-28-2008; IN COMMERCE 10-28-2008.

CLASS 9—(Continued).

4,118,901. BROCKMAN, LOUIS, LONG ISLAND CITY, NY.
SN 77-693,457. PUB. 3-2-2010, FILED 3-18-2009.

**BALLROOM DANCING FOR TOUGH
GUYS**

THE MARK CONSISTS OF STANDARD CHARACTERS WITHOUT CLAIM TO ANY PARTICULAR FONT, STYLE, SIZE, OR COLOR.

NO CLAIM IS MADE TO THE EXCLUSIVE RIGHT TO USE "BALLROOM DANCING", APART FROM THE MARK AS SHOWN.

FOR DVDS FEATURING DANCE ROUTINES, COMEDY AND INFORMATION ABOUT BALLROOM DANCING AND ENTERTAINMENT IN THE NATURE OF BALLROOM DANCING (U.S. CLS. 21, 23, 26, 36 AND 38).
FIRST USE 11-29-2009; IN COMMERCE 11-29-2009.

4,118,914. CELLULAR BIOENGINEERING, INC., HONOLULU, HI. SN 77-733,112. PUB. 10-6-2009, FILED 5-8-2009.

TRUTAG

THE MARK CONSISTS OF STANDARD CHARACTERS WITHOUT CLAIM TO ANY PARTICULAR FONT, STYLE, SIZE, OR COLOR.

FOR LABELS CARRYING OPTICALLY RECORDED OR ENCODED INFORMATION; ENCODED MICRO PARTICULATES, TAGS AND TAGGANTS OF POLYMER, PLASTIC, SILICON, SILICATE, SILICA, AND COMBINATIONS THEREOF FOR USE IN THE FIELD OF PASSIVE LABELING, TRACING OR TRACKING OF PERSONS, ANIMALS, VEHICLES, JEWELS, JEWELRY, INTEGRATED CIRCUITS, ELECTRONICS, FOOD ITEMS, MEDICINE AND MEDICAL PRODUCTS, ATHLETIC SHOES AND APPAREL, MUSICAL INSTRUMENTS, BEVERAGES, WINE, SPIRITS, SPORTS EQUIPMENT AND MEMORABILIA, TOYS, COSMETICS, CLOTHING, WATCHES, PURSES, PACKAGES, PACKAGING MATERIALS, LABELS, OR GOODS OF ANY KIND; ENCODED MICRO PARTICULATES, TAGS AND TAGGANTS OF POLYMER, PLASTIC, SILICON, SILICATE, SILICA AND COMBINATIONS THEREOF INTEGRATED INTO A SECURITY FIBER USED TO MARK TEXTILES, DOCUMENTS, OR CURRENCY; OPTICALLY ENCODED MICRO PARTICULATES, TAGS AND TAGGANTS FOR GOODS OF ANY KIND; OPTICALLY ENCODED MICRO PARTICULATES, TAGS AND TAGGANTS FOR USE IN THE FIELDS OF IDENTIFICATION, ACCESS TO INFRASTRUCTURE AND RESOURCES, TIMEKEEPING, AND SECURITY; OPTICAL, ELECTRONIC, AND ELECTRO-OPTICAL READERS OF OPTICALLY ENCODED MICRO PARTICULATES, TAGS AND TAGGANTS; OPTICAL, ELECTRONIC, AND ELECTRO-OPTICAL READERS OF OPTICALLY ENCODED MICRO PARTICULATES, TAGS AND TAGGANTS EFFECTIVE AT SHORT RANGE OR LONG RANGE; COMPUTER SOFTWARE FOR READING IMAGES OF OPTICALLY ENCODED MICRO PARTICULATES, TAGS AND TAGGANTS; MAGNETICALLY ENCODED IDENTIFICATION BRACELETS, KEY CARDS, PRE-PAID TELEPHONE CALLING CARDS, CREDIT CARDS, PRE-PAID GIFT CARDS, FIDELITY CARDS, POLICYHOLDER CARDS, AND ACCESS CARDS; OPTICALLY ENCODED IDENTIFICATION

CLASS 9—(Continued).

BRACELETS, KEY CARDS, PRE-PAID TELEPHONE CALLING CARDS, CREDIT CARDS, PRE-PAID GIFT CARDS, FIDELITY CARDS, POLICYHOLDER CARDS, AND ACCESS CARDS; OPTICALLY ENCODED MICRO PARTICULATES, TAGS AND TAGGANTS FOR USE IN FORENSICS, QUALITY CONTROL, AND DETECTION OF INTRUSION, BREAKAGE, OR ALTERATION; OPTICALLY ENCODED MICRO PARTICULATES, TAGS AND TAGGANTS FOR APPLICATION IN OR ON GOODS BY SPRAYING, PAINTING, EMBEDDING, ADSORPTION, ABSORPTION, MIXING, COATING, AND ADHESION; OPTICAL, ELECTRONIC, AND ELECTRO-OPTICAL READERS THAT PROVIDE AUTOMATIC AUTHENTICATION OF TAGGED ITEMS; OPTICAL, ELECTRONIC, AND ELECTRO-OPTICAL READERS THAT PROVIDE AUTOMATIC AUTHENTICATION OF TAGGED ITEMS EFFECTIVE AT SHORT RANGE OR LONG RANGE; COMPUTER SOFTWARE THAT PROVIDES AUTOMATIC AUTHENTICATION OF TAGGED ITEMS; COMPUTER SOFTWARE FOR ENCODING AND DECODING OPTICALLY ENCODED MICRO PARTICULATES, TAGS, AND TAGGANTS; COMPUTER-BASED HARDWARE FOR ENCODING AND DECODING OPTICALLY ENCODED MICRO PARTICULATES, TAGS, AND TAGGANTS (U.S. CLS. 21, 23, 26, 36 AND 38).
FIRST USE 5-1-2009; IN COMMERCE 1-23-2012.

4,118,918. SOLIDTHINKING, INC., TROY, MI. SN 77-744,543.
PUB. 6-1-2010, FILED 5-26-2009.

CONSTRUCTION TREE

THE MARK CONSISTS OF STANDARD CHARACTERS WITHOUT CLAIM TO ANY PARTICULAR FONT, STYLE, SIZE, OR COLOR.

NO CLAIM IS MADE TO THE EXCLUSIVE RIGHT TO USE "CONSTRUCTION", APART FROM THE MARK AS SHOWN.

FOR COMPUTER SOFTWARE FOR USE IN MODIFYING AND MANAGING THE LINEAGE OF COMPUTER GENERATED MODELS IN THE FIELD OF STYLING, DESIGN AND ENGINEERING (U.S. CLS. 21, 23, 26, 36 AND 38).

FIRST USE 4-0-2008; IN COMMERCE 4-0-2008.

CLASS 9—(Continued).

4,118,921. KANBAR ENTERTAINMENT, LLC, SAN FRANCISCO, CA. SN 77-752,321. PUB. 9-27-2011, FILED 6-4-2009.

HOODWINKED

THE MARK CONSISTS OF STANDARD CHARACTERS WITHOUT CLAIM TO ANY PARTICULAR FONT, STYLE, SIZE, OR COLOR.

FOR PRE-RECORDED CDS, VIDEO TAPES, LASER DISKS AND DVDS FEATURING A SERIES OF MOVIES; PRE-RECORDED DVDS FEATURING A SERIES OF MOVIES; MOTION PICTURE FILMS FEATURING CHILDREN'S ENTERTAINMENT; VIDEOS IN THE FIELD OF CHILDREN'S ENTERTAINMENT; MOTION PICTURE FILMS FEATURING COMEDY, DRAMA, ACTION, ADVENTURE AND/OR ANIMATION, AND MOTION PICTURE FILMS FOR BROADCAST ON TELEVISION FEATURING COMEDY, DRAMA, ACTION, ADVENTURE AND/OR ANIMATION; PRERECORDED VINYL RECORDS, AUDIO TAPES, AUDIO-VIDEO TAPES, AUDIO VIDEO CASSETTES, AUDIO VIDEO DISCS, COMPACT DISCS, AND DIGITAL VERSATILE DISCS FEATURING MUSIC, COMEDY, DRAMA, ACTION, ADVENTURE, AND/OR ANIMATION; DOWNLOADABLE FILMS AND TELEVISION PROGRAMS FEATURING COMEDY, DRAMA, ACTION, ADVENTURE AND/OR ANIMATION PROVIDED VIA A VIDEO-ON-DEMAND SERVICE; DOWNLOADABLE MP3 FILES FEATURING MUSIC; AUDIO TAPES AND BOOKLETS SOLD AS A UNIT FEATURING COMEDY, DRAMA, ACTION, ADVENTURE, ANIMATION AND MUSIC INFORMATION; VIDEO, COMPUTER AND OTHER INTERACTIVE GAME PROGRAMS (U.S. CLS. 21, 23, 26, 36 AND 38).

FIRST USE 8-16-2011; IN COMMERCE 8-16-2011.

4,118,933. HTC CORPORATION, TAOYUAN CITY, TAIWAN. SN 77-793,906. PUB. 11-23-2010, FILED 7-30-2009.

HTC PURE

THE MARK CONSISTS OF STANDARD CHARACTERS WITHOUT CLAIM TO ANY PARTICULAR FONT, STYLE, SIZE, OR COLOR.

CLASS 9—(Continued).

OWNER OF U.S. REG. NOS. 3,532,002, 3,636,164, AND OTHERS.

FOR MOBILE PHONES, SMART PHONES, CELL PHONES, WIRELESS COMMUNICATION DEVICES FOR VOICE, AUDIO, DATA OR IMAGE TRANSMISSION, PORTABLE COMPUTERS, AND PERSONAL DIGITAL ASSISTANTS; COMPUTER HARDWARE AND SOFTWARE FOR ENABLING, OPERATING, ENHANCING, CUSTOMIZING, UPDATING AND MANAGING MOBILE, PORTABLE, SMART, VOICE-OVER-INTERNET-PROTOCOL, AND WIRELESS TELEPHONES AND DEVICES; USER INTERFACE SOFTWARE; COMPUTER HARDWARE AND SOFTWARE FOR DELIVERING, ENABLING, CREATING, ENHANCING, CUSTOMIZING, UPDATING, AND MANAGING USER INTERFACING, TELECOMMUNICATIONS AND TELECOMMUNICATIONS SERVICES; COMPUTER HARDWARE AND SOFTWARE FOR TRANSMITTING AND RECEIVING VOICE, IMAGE, DATA, AUDIO, VIDEO AND MULTIMEDIA CONTENT; WIRELESS MODEMS; ACCESSORIES FOR THE ABOVE GOODS, NAMELY, HEADSETS, HEADSETS WITH WIRELESS TRANSMISSION FUNCTION, CONNECTION CABLES, CRADLES, MOUNTS, FACE PLATES, REPLACEMENT PARTS, BATTERIES, ADAPTORS, CHARGERS, CASES, POUCHES, IN-VEHICLE CHARGERS, IN-VEHICLE HOLDERS (U.S. CLS. 21, 23, 26, 36 AND 38).

FIRST USE 10-5-2009; IN COMMERCE 10-5-2009.

4,118,946. ANDALYZE, INC., CHAMPAIGN, IL. SN 77-836,048. PUB. 2-23-2010, FILED 9-28-2009.

ANDALYZE

THE MARK CONSISTS OF STANDARD CHARACTERS WITHOUT CLAIM TO ANY PARTICULAR FONT, STYLE, SIZE, OR COLOR.

FOR ELECTRONIC-BASED INSTRUMENTS FOR MEASURING ENVIRONMENTAL PARAMETERS INCLUDING HUMIDITY, MOLD, BACTERIA, AIR QUALITY AND WATER QUALITY; SCIENTIFIC APPARATUS AND INSTRUMENTS FOR MEASURING RELATIVE DNA/RNA AND PROTEIN AND PARTS AND FITTINGS THEREFOR; SCIENTIFIC INSTRUMENTS, NAMELY, ELECTRONIC ANALYZERS FOR MEASURING, TESTING AND DETECTING CONTAMINANTS AND ENVIRONMENTAL POLLUTANTS; WATER TESTING INSTRUMENTATION FOR MONITORING AND DETECTING CONTAMINATION (U.S. CLS. 21, 23, 26, 36 AND 38).

FIRST USE 8-26-2009; IN COMMERCE 2-1-2010.

CLASS 9—(Continued).

4,118,947. ANDALYZE, INC., CHAMPAIGN, IL. SN 77-836,054. PUB. 2-23-2010, FILED 9-28-2009.



THE COLOR(S) BLUE, GREEN, WHITE, AND BLACK IS/ARE CLAIMED AS A FEATURE OF THE MARK.

THE MARK CONSISTS OF A BLUE RECTANGLE CONTAINING A GREEN AND BLUE DOUBLE HELIX SHAPE ABOVE WHICH IS THE LETTER "A" IN WHITE; HORIZONTAL BLUE AND GREEN LINES EXTEND TO THE RIGHT FROM THE LOWER RIGHT-HAND CORNER OF THE RECTANGLE AND TERMINATE IN A BLUE AND GREEN STAR SHAPE; ABOVE THE BLUE AND GREEN HORIZONTAL LINES ARE THE LETTERS "NDALYZE" IN BLACK.

FOR ELECTRONIC-BASED INSTRUMENTS FOR MEASURING ENVIRONMENTAL PARAMETERS INCLUDING HUMIDITY, MOLD, BACTERIA, AIR QUALITY AND WATER QUALITY; SCIENTIFIC APPARATUS AND INSTRUMENTS FOR MEASURING RELATIVE DNA/RNA AND PROTEIN AND PARTS AND FITTINGS THEREFOR; SCIENTIFIC INSTRUMENTS, NAMELY, ELECTRONIC ANALYZERS FOR MEASURING, TESTING AND DETECTING CONTAMINANTS AND ENVIRONMENTAL POLLUTANTS; WATER TESTING INSTRUMENTATION FOR MONITORING AND DETECTING CONTAMINATION (U.S. CLS. 21, 23, 26, 36 AND 38).

FIRST USE 8-26-2009; IN COMMERCE 2-1-2010.

4,118,948. ANDALYZE, INC., CHAMPAIGN, IL. SN 77-836,061. PUB. 2-23-2010, FILED 9-28-2009.

POWERED BY DNA

THE MARK CONSISTS OF STANDARD CHARACTERS WITHOUT CLAIM TO ANY PARTICULAR FONT, STYLE, SIZE, OR COLOR.

FOR ELECTRONIC-BASED INSTRUMENTS FOR MEASURING ENVIRONMENTAL PARAMETERS INCLUDING HUMIDITY, MOLD, BACTERIA, AIR QUALITY AND WATER QUALITY; SCIENTIFIC APPARATUS AND INSTRUMENTS FOR MEASURING RELATIVE DNA/RNA AND PROTEIN AND PARTS AND FITTINGS THEREFOR; SCIENTIFIC INSTRUMENTS, NAMELY, ELECTRONIC ANALYZERS FOR MEASURING, TESTING AND DETECTING CONTAMINANTS AND ENVIRONMENTAL POLLUTANTS; WATER TESTING INSTRUMENTATION FOR MONITORING AND DETECTING CONTAMINATION (U.S. CLS. 21, 23, 26, 36 AND 38).

FIRST USE 8-26-2009; IN COMMERCE 2-1-2010.

CLASS 9—(Continued).

4,118,950. JUMPSOFT INC, VIENNA, VA. SN 77-844,530. PUB. 7-13-2010, FILED 10-8-2009.

Jumpsoft

THE MARK CONSISTS OF STANDARD CHARACTERS WITHOUT CLAIM TO ANY PARTICULAR FONT, STYLE, SIZE, OR COLOR.

FOR COMPUTER SOFTWARE FOR APPLICATION, PROCESS AND DATABASE MANAGEMENT (U.S. CLS. 21, 23, 26, 36 AND 38).

FIRST USE 1-26-2012; IN COMMERCE 1-26-2012.

4,118,955. VIZUALL, INC., AKA SCHEDUALL, HOLLYWOOD, FL. SN 77-855,782. PUB. 9-13-2011, FILED 10-23-2009.

WEAVE

THE MARK CONSISTS OF STANDARD CHARACTERS WITHOUT CLAIM TO ANY PARTICULAR FONT, STYLE, SIZE, OR COLOR.

FOR COMPUTER SOFTWARE FOR PROJECT WORKFLOW AND PROCESS BASED SCHEDULING RELATED TO BROADCAST, MEDIA, PRODUCTION AND TELECOM INDUSTRIES, SATELLITE AND TERRESTRIAL NETWORKS; COMPUTER SOFTWARE TO CREATE, MANAGE, TRACK, FORECAST, REPORT AND SCHEDULE PROJECTS AND PROCESSES INTERNALLY OR COLLABORATIVELY ACROSS PERSONS AND ENTITIES RELATED TO BROADCAST, MEDIA, PRODUCTION AND TELECOM INDUSTRIES, SATELLITE AND TERRESTRIAL NETWORKS (U.S. CLS. 21, 23, 26, 36 AND 38).

FIRST USE 5-15-2009; IN COMMERCE 8-1-2011.

4,118,975. FAIRFIELD INDUSTRIES INCORPORATED, SUGAR LAND, TX. SN 77-883,931. PUB. 6-1-2010, FILED 12-2-2009.

FAIRFIELDNODAL

THE MARK CONSISTS OF STANDARD CHARACTERS WITHOUT CLAIM TO ANY PARTICULAR FONT, STYLE, SIZE, OR COLOR.

OWNER OF U.S. REG. NO. 3,295,201.
FOR SEISMIC DETECTION AND SEISMIC DATA ACQUISITION INSTRUMENTS (U.S. CLS. 21, 23, 26, 36 AND 38).

FIRST USE 1-1-2010; IN COMMERCE 1-1-2010.

CLASS 9—(Continued).

4,118,979. BELKIN INTERNATIONAL, INC., COMPTON, CA. SN 77-889,768. PUB. 10-26-2010, FILED 12-9-2009.

DAILY DJ

THE MARK CONSISTS OF STANDARD CHARACTERS WITHOUT CLAIM TO ANY PARTICULAR FONT, STYLE, SIZE, OR COLOR.

FOR COMPUTER SOFTWARE APPLICATIONS AND UPDATES FOR MANAGING DIGITAL MUSIC FILES, SOLD IN DOWNLOADABLE FORM AND AS A COMPONENT PART OF NETWORKING AND DIGITAL COMMUNICATIONS DEVICES (U.S. CLS. 21, 23, 26, 36 AND 38).

FIRST USE 4-0-2010; IN COMMERCE 4-0-2010.

4,118,984. JOHN MEZZALINGUA ASSOCIATES, INC., DBA PPC, EAST SYRACUSE, NY. SN 77-897,321. PUB. 6-15-2010, FILED 12-18-2009.

PERFECT GUARD

THE MARK CONSISTS OF STANDARD CHARACTERS WITHOUT CLAIM TO ANY PARTICULAR FONT, STYLE, SIZE, OR COLOR.

FOR CONNECTION CABLES (U.S. CLS. 21, 23, 26, 36 AND 38).

FIRST USE 10-0-2011; IN COMMERCE 10-0-2011.

4,118,989. AB SCIEX PTE. LTD., SINGAPORE, SINGAPORE. SN 77-905,634. PUB. 5-18-2010, FILED 1-5-2010.

PEAKVIEW

THE MARK CONSISTS OF STANDARD CHARACTERS WITHOUT CLAIM TO ANY PARTICULAR FONT, STYLE, SIZE, OR COLOR.

FOR MASS SPECTROMETRY SOFTWARE (U.S. CLS. 21, 23, 26, 36 AND 38).

FIRST USE 6-1-2010; IN COMMERCE 6-1-2010.

CLASS 9—(Continued).

4,119,001. ZRODIA, LLC, RENO, NV. SN 77-913,660. PUB. 11-9-2010, FILED 1-17-2010.

ZRODIA

THE MARK CONSISTS OF STANDARD CHARACTERS WITHOUT CLAIM TO ANY PARTICULAR FONT, STYLE, SIZE, OR COLOR.

"ZRODIA" DOES NOT IDENTIFY A LIVING INDIVIDUAL.

THE WORDING "ZRODIA" HAS NO MEANING IN A FOREIGN LANGUAGE.

FOR ELECTRONIC MEMORIES; MEMORY EXPANSION MODULES; CHIP CARRIERS, NAMELY, SEMICONDUCTOR CHIP HOUSINGS; HOUSINGS FOR PRINTED CIRCUIT BOARDS; INTERFACE CIRCUITS FOR VIDEO CAMERAS; DATA ACQUISITION SYSTEMS, COMPRISING METER COLLECTORS, OPERATIONS LOG EXTRACTORS, EVENT LOG EXTRACTORS; AUDIO-VISUAL EQUIPMENT, NAMELY, AUDIO VIDEO RECORDERS, AUDIO VIDEO PLAYERS, AUDIO VIDEO EDITING STATIONS; DATA TRANSFER EQUIPMENT, NAMELY, BULK DATA COPIERS, AUDIO VIDEO DOWNLOAD STATIONS, METER DATA DOWNLOAD STATIONS, LOG DATA DOWNLOAD STATIONS (U.S. CLS. 21, 23, 26, 36 AND 38).

FIRST USE 10-3-2011; IN COMMERCE 10-3-2011.

4,119,014. HUNOLT, JUSTIN ANTHONY, AKA COUNTER-GROOVE, MIRAMAR BEACH, FL. SN 77-926,175. PUB. 8-31-2010, FILED 2-2-2010.



THE MARK CONSISTS OF THE WORDING "COUNTER-GROOVE" FEATURING THE LETTERS "CG" ABOVE WITH THE LETTER "C" IN THE SHAPE OF A CHEVRON AND THE LETTER "G" IN THE SHAPE OF AN INCOMPLETE DIAMOND. THE RECTANGLE BORDER SHAPE IS NOT PART OF THE MARK.

FOR DIGITAL MEDIA, NAMELY, PRE-RECORDED VIDEO CASSETTES, DIGITAL VIDEO DISCS, DIGITAL VERSATILE DISCS, DOWNLOADABLE AUDIO AND VIDEO RECORDINGS, DVDS, AND HIGH DEFINITION DIGITAL DISCS ALL IN THE FIELD OF MUSIC RECORDINGS AND MOTION GRAPHICS (U.S. CLS. 21, 23, 26, 36 AND 38).

FIRST USE 10-10-2011; IN COMMERCE 1-26-2012.

CLASS 9—(Continued).

4,119,017. OTOVATION, LLC, KING OF PRUSSIA, PA. SN 77-926,542. PUB. 6-22-2010, FILED 2-3-2010.

OTOPRO

THE MARK CONSISTS OF STANDARD CHARACTERS WITHOUT CLAIM TO ANY PARTICULAR FONT, STYLE, SIZE, OR COLOR.

FOR ACOUSTIC AND AUDIOLOGIC TEST EQUIPMENT AND SOFTWARE (U.S. CLS. 21, 23, 26, 36 AND 38).

FIRST USE 11-15-2011; IN COMMERCE 11-15-2011.

4,119,037. D4D TECHNOLOGIES, LLC, RICHARDSON, TX. SN 77-941,541. PUB. 7-27-2010, FILED 2-22-2010.

E4D COMPASS

THE MARK CONSISTS OF STANDARD CHARACTERS WITHOUT CLAIM TO ANY PARTICULAR FONT, STYLE, SIZE, OR COLOR.

OWNER OF U.S. REG. NO. 3,399,669.
FOR COMPUTER SOFTWARE FOR DESIGNING DENTAL RESTORATIONS (U.S. CLS. 21, 23, 26, 36 AND 38).

FIRST USE 10-0-2011; IN COMMERCE 10-0-2011.

4,119,039. NOSY CROW LIMITED, LONDON, UNITED KINGDOM. SN 77-946,714. PUB. 6-14-2011, FILED 2-28-2010.

appiness

THE MARK CONSISTS OF STANDARD CHARACTERS WITHOUT CLAIM TO ANY PARTICULAR FONT, STYLE, SIZE, OR COLOR.

FOR DOWNLOADABLE ELECTRONIC PUBLICATIONS IN THE NATURE OF CHILDREN'S AND ADULT BOOKS IN THE FIELD OF FICTION AND NON-FICTION; DOWNLOADABLE ELECTRONIC GAMES VIA THE INTERNET AND WIRELESS DEVICES (U.S. CLS. 21, 23, 26, 36 AND 38).

FIRST USE 11-15-2011; IN COMMERCE 11-15-2011.

CLASS 9—(Continued).

4,119,043. SHIRE HUMAN GENETIC THERAPIES, INC., LEXINGTON, MA. SN 77-955,363. PUB. 8-3-2010, FILED 3-10-2010.

iGau

THE MARK CONSISTS OF STANDARD CHARACTERS WITHOUT CLAIM TO ANY PARTICULAR FONT, STYLE, SIZE, OR COLOR.

FOR DOWNLOADABLE SOFTWARE IN THE NATURE OF A MOBILE APPLICATION FOR USE BY GAUCHER'S DISEASE PATIENTS TO ORGANIZE INFORMATION, DATES AND EVENTS RELATING TO THEIR MEDICAL CONDITION, AND TO TRACK THE STATUS OF THE DISEASE OVER TIME (U.S. CLS. 21, 23, 26, 36 AND 38).

FIRST USE 5-12-2010; IN COMMERCE 5-12-2010.

4,119,067. ANAND PAG INC, IRVING, TX. SN 85-004,182. PUB. 5-10-2011, FILED 4-1-2010.

Process Factory Mobile

THE MARK CONSISTS OF STANDARD CHARACTERS WITHOUT CLAIM TO ANY PARTICULAR FONT, STYLE, SIZE, OR COLOR.

NO CLAIM IS MADE TO THE EXCLUSIVE RIGHT TO USE "MOBILE", APART FROM THE MARK AS SHOWN.

FOR COMPUTER APPLICATION SOFTWARE FOR USE WITH USER INTERFACES AND WORKFLOW FOR BUSINESS APPLICATIONS ASSOCIATED WITH ERP SYSTEMS ON LAPTOPS, DESKTOPS AND MOBILE DEVICES, NAMELY, MOBILE PHONES, PDAS, HANDHELD COMPUTERS, TABLETS AND SMART PHONES; COMPUTER SOFTWARE FOR ENABLING BUSINESS PROCESSES ON MOBILE DEVICES, NAMELY, MOBILE PHONES, PDAS, HANDHELD COMPUTERS AND SMART PHONES BY COMMUNICATING TO BACK END DATABASE SYSTEMS USING WEB SERVICES OR HTTP SERVICE CALLS (U.S. CLS. 21, 23, 26, 36 AND 38).

FIRST USE 1-26-2010; IN COMMERCE 1-26-2010.

4,119,068. ANAND PAG INC, IRVING, TX. SN 85-004,201. PUB. 5-17-2011, FILED 4-1-2010.

PF Mobile

THE MARK CONSISTS OF STANDARD CHARACTERS WITHOUT CLAIM TO ANY PARTICULAR FONT, STYLE, SIZE, OR COLOR.

CLASS 9—(Continued).

NO CLAIM IS MADE TO THE EXCLUSIVE RIGHT TO USE "MOBILE", APART FROM THE MARK AS SHOWN.

FOR COMPUTER APPLICATION SOFTWARE FOR USE WITH USER INTERFACES AND WORKFLOW FOR BUSINESS APPLICATIONS ASSOCIATED WITH ERP SYSTEMS ON LAPTOPS, DESKTOPS AND MOBILE DEVICES, NAMELY, MOBILE PHONES, PDAS, HANDHELD COMPUTERS, TABLETS AND SMART PHONES; COMPUTER SOFTWARE FOR ENABLING BUSINESS PROCESSES ON MOBILE DEVICES, NAMELY, MOBILE PHONES, PDAS, HANDHELD COMPUTERS AND SMART PHONES BY COMMUNICATING TO BACK END DATABASE SYSTEMS USING WEB SERVICES OR HTTP SERVICE CALLS (U.S. CLS. 21, 23, 26, 36 AND 38).
FIRST USE 1-26-2010; IN COMMERCE 1-26-2010.

4,119,069. ANAND PAG INC, IRVING, TX. SN 85-004,214.
PUB. 5-3-2011, FILED 4-1-2010.

Collaboration On-the-Go

THE MARK CONSISTS OF STANDARD CHARACTERS WITHOUT CLAIM TO ANY PARTICULAR FONT, STYLE, SIZE, OR COLOR.

FOR COMPUTER APPLICATION SOFTWARE FOR USE WITH USER INTERFACES AND WORKFLOW FOR BUSINESS APPLICATIONS ASSOCIATED WITH ERP SYSTEMS ON LAPTOPS, DESKTOPS AND MOBILE DEVICES, NAMELY, MOBILE PHONES, PDAS, HANDHELD COMPUTERS, TABLETS AND SMART PHONES; COMPUTER SOFTWARE FOR ENABLING BUSINESS PROCESSES ON MOBILE DEVICES, NAMELY, MOBILE PHONES, PDAS, HANDHELD COMPUTERS AND SMART PHONES BY COMMUNICATING TO BACK END DATABASE SYSTEMS USING WEB SERVICES OR HTTP SERVICE CALLS (U.S. CLS. 21, 23, 26, 36 AND 38).
FIRST USE 1-26-2010; IN COMMERCE 1-26-2010.

4,119,078. MACE TRADEMARK II, INC., BENNINGTON, VT.
SN 85-018,290. PUB. 11-9-2010, FILED 4-20-2010.

MaceView

THE MARK CONSISTS OF STANDARD CHARACTERS WITHOUT CLAIM TO ANY PARTICULAR FONT, STYLE, SIZE, OR COLOR.

OWNER OF U.S. REG. NOS. 2,010,600, 2,890,851, AND 3,808,019.

FOR VIDEO SECURITY SURVEILLANCE SYSTEM CONSISTING OF VIDEO OBSERVATION MONITORS, DIGITAL VIDEO RECORDERS, CAMERAS, AUDIO SENSOR AND POWER SUPPLIES; AND VIDEO SECURITY SURVEILLANCE SYSTEM PARTS, NAMELY, VIDEO OBSERVATION MONITORS, DIGITAL VIDEO RECORDERS, CAMERAS, AUDIO SENSOR AND POWER SUPPLIES (U.S. CLS. 21, 23, 26, 36 AND 38).
FIRST USE 10-31-2010; IN COMMERCE 10-31-2010.

CLASS 9—(Continued).

4,119,079. MACE TRADEMARK II, INC., BENNINGTON, VT.
SN 85-018,492. PUB. 11-9-2010, FILED 4-20-2010.

MacePro

THE MARK CONSISTS OF STANDARD CHARACTERS WITHOUT CLAIM TO ANY PARTICULAR FONT, STYLE, SIZE, OR COLOR.

OWNER OF U.S. REG. NOS. 2,010,600, 2,890,851, AND 3,808,019.

FOR VIDEO SECURITY SURVEILLANCE SYSTEM CONSISTING OF VIDEO OBSERVATION MONITORS, DIGITAL VIDEO RECORDERS, CAMERAS, AUDIO SENSOR AND POWER SUPPLIES; AND VIDEO SECURITY SURVEILLANCE SYSTEM PARTS, NAMELY, VIDEO OBSERVATION MONITORS, DIGITAL VIDEO RECORDERS, CAMERAS, AUDIO SENSOR AND POWER SUPPLIES (U.S. CLS. 21, 23, 26, 36 AND 38).
FIRST USE 10-31-2010; IN COMMERCE 10-31-2010.

4,119,080. TCT MOBILE LIMITED, IRVINE, CA. SN 85-018,804. PUB. 3-8-2011, FILED 4-20-2010.

ONE TOUCH TRIBE

THE MARK CONSISTS OF STANDARD CHARACTERS WITHOUT CLAIM TO ANY PARTICULAR FONT, STYLE, SIZE, OR COLOR.

NO CLAIM IS MADE TO THE EXCLUSIVE RIGHT TO USE "ONE TOUCH", APART FROM THE MARK AS SHOWN.

FOR CELLULAR TELEPHONES (U.S. CLS. 21, 23, 26, 36 AND 38).

FIRST USE 5-1-2011; IN COMMERCE 5-1-2011.

4,119,084. LOKO, INDUSTRIES, SAN RAMON, CA. SN 85-022,085. PUB. 9-28-2010, FILED 4-23-2010.

Grab The Advantage!

THE MARK CONSISTS OF STANDARD CHARACTERS WITHOUT CLAIM TO ANY PARTICULAR FONT, STYLE, SIZE, OR COLOR.

FOR HAND GRIPS FOR VIDEO GAME CONSOLES (U.S. CLS. 21, 23, 26, 36 AND 38).
FIRST USE 12-1-2011; IN COMMERCE 1-1-2012.

CLASS 9—(Continued).

4,119,086. POWELL ELECTRICAL SYSTEMS, INC., HOUSTON, TX. SN 85-026,475. PUB. 10-5-2010, FILED 4-29-2010.

POWL VAC100

THE MARK CONSISTS OF STANDARD CHARACTERS WITHOUT CLAIM TO ANY PARTICULAR FONT, STYLE, SIZE, OR COLOR.

OWNER OF U.S. REG. NOS. 1,295,815, 2,002,507, AND 2,680,911.

FOR VACUUM CIRCUIT BREAKERS FOR INCORPORATION WITHIN MEDIUM VOLTAGE SWITCHGEAR (U.S. CLS. 21, 23, 26, 36 AND 38).

FIRST USE 1-31-2011; IN COMMERCE 1-31-2011.

4,119,102. MEDUZA SYSTEMS LLC, IRVINE, CA. SN 85-038,654. PUB. 5-10-2011, FILED 5-14-2010.

MEDUZA

THE MARK CONSISTS OF STANDARD CHARACTERS WITHOUT CLAIM TO ANY PARTICULAR FONT, STYLE, SIZE, OR COLOR.

FOR CAMERAS (U.S. CLS. 21, 23, 26, 36 AND 38).

FIRST USE 11-4-2010; IN COMMERCE 4-4-2011.

4,119,103. THE RANDOM ACTS OF KINDNESS FOUNDATION, DENVER, CO. SN 85-038,961. PUB. 11-23-2010, FILED 5-14-2010.

**THE RANDOM ACTS OF
KINDNESS FOUNDATION**

THE MARK CONSISTS OF STANDARD CHARACTERS WITHOUT CLAIM TO ANY PARTICULAR FONT, STYLE, SIZE, OR COLOR.

CLASS 9—(Continued).

NO CLAIM IS MADE TO THE EXCLUSIVE RIGHT TO USE "FOUNDATION", APART FROM THE MARK AS SHOWN.

FOR DOWNLOADABLE DIGITAL MEDIA, NAMELY, IMAGES IN THE NATURE OF CALENDARS, IMAGES IN THE NATURE OF PRINTABLE BOOK MARKS, IMAGES IN THE NATURE OF PRINTABLE POSTERS, AND IMAGES IN THE NATURE OF PRINTABLE BANNERS, ALL PROVIDED VIA A GLOBAL COMPUTER NETWORK; DOWNLOADABLE COMPUTER SOFTWARE FOR PROVIDING USERS WITH INFORMATION AND REMINDERS TO DO GOOD DEEDS; DOWNLOADABLE SOFTWARE IN THE NATURE OF MOBILE APPLICATIONS FOR PROVIDING USERS WITH INFORMATION AND REMINDERS TO DO GOOD DEEDS; VIDEO RECORDINGS FEATURING CONTENT RELATED TO DOING GOOD DEEDS FOR OTHERS (U.S. CLS. 21, 23, 26, 36 AND 38).

FIRST USE 11-30-2010; IN COMMERCE 11-30-2010.

4,119,120. PERCEPTRON, INC., PLYMOUTH, MI. SN 85-046,649. PUB. 10-26-2010, FILED 5-24-2010.

UP IS UP

THE MARK CONSISTS OF STANDARD CHARACTERS WITHOUT CLAIM TO ANY PARTICULAR FONT, STYLE, SIZE, OR COLOR.

FOR OPTICAL INSPECTION APPARATUS FOR COMMERCIAL USE (U.S. CLS. 21, 23, 26, 36 AND 38).

FIRST USE 5-0-2008; IN COMMERCE 5-0-2008.

4,119,145. MICROJET TECHNOLOGY CO., LTD, HSINCHU, TAIWAN. SN 85-058,384. PUB. 5-31-2011, FILED 6-9-2010.

CometrueJet

THE MARK CONSISTS OF STANDARD CHARACTERS WITHOUT CLAIM TO ANY PARTICULAR FONT, STYLE, SIZE, OR COLOR.

FOR THREE DIMENSIONAL PRINTER; RAPID PROTOTYPING SYSTEMS, COMPRISING A COMPUTER CONTROLLED APPARATUS, BASED ON INK-JET TECHNOLOGY, FOR THE PRODUCTION OF THREE-DIMENSIONAL MODELS; COMPUTER SOFTWARE USED WITH A 3D RAPID PROTOTYPING SCANNER FOR RECEIVING, INTERPRETING, MANIPULATING, AND TRANSMITTING DATA; SCANNERS USED TO SCAN 3D OBJECTS AND TO TRANSMIT THAT DATA TO RAPID PROTOTYPING SYSTEMS, COMPRISING A COMPUTER CONTROLLED APPARATUS, BASED ON INK-JET TECHNOLOGY, FOR THE PRODUCTION OF THREE-DIMENSIONAL MODELS; CAMERA USED TO PHOTOGRAPHY 3D OBJECTS AND TO TRANSMIT THAT DATA TO RAPID PROTOTYPING SYSTEMS, COMPRISING A COMPUTER CONTROLLED APPARATUS, BASED ON INK-JET TECHNOLOGY, FOR THE PRODUCTION OF THREE-DIMENSIONAL MODELS (U.S. CLS. 21, 23, 26, 36 AND 38).

FIRST USE 12-21-2011; IN COMMERCE 12-21-2011.

CLASS 9—(Continued).

4,119,151. ADDRESSVISION INC., LA CROSSE, WI. SN 85-061,986. PUB. 6-7-2011, FILED 6-14-2010.

MAILFLOW

THE MARK CONSISTS OF STANDARD CHARACTERS WITHOUT CLAIM TO ANY PARTICULAR FONT, STYLE, SIZE, OR COLOR.

FOR COMPUTER SOFTWARE FOR ANALYZING AND PROCESSING MAIL PIECES, AND FOR OPTIMIZING POSTAGE SAVINGS ASSOCIATED WITH METHODS OF MAIL DELIVERY, FOR USE WITHIN THE PHYSICAL MAIL PROCESSING INDUSTRY (U.S. CLS. 21, 23, 26, 36 AND 38).

FIRST USE 5-5-2010; IN COMMERCE 5-5-2010.

4,119,154. MIRADA MEDICAL LIMITED, OXFORD, OXFORDSHIRE, UNITED KINGDOM. SN 85-064,971. PUB. 11-16-2010, FILED 6-17-2010.

CASEACCESS

THE MARK CONSISTS OF STANDARD CHARACTERS WITHOUT CLAIM TO ANY PARTICULAR FONT, STYLE, SIZE, OR COLOR.

FOR MEDICAL SOFTWARE FOR PROCESSING AND CONVERTING IMAGES PRODUCED BY MEDICAL SCANNING DEVICES INTO COMPUTER READABLE FORM ALLOWING FOR THE VIEWING AND PRINTING OF THE IMAGES (U.S. CLS. 21, 23, 26, 36 AND 38).

FIRST USE 0-0-2011; IN COMMERCE 0-0-2011.

4,119,161. X-RAY OPTICAL SYSTEMS, INC., EAST GREENBUSH, NY. SN 85-067,680. PUB. 5-10-2011, FILED 6-21-2010.

SIGNAL

THE MARK CONSISTS OF STANDARD CHARACTERS WITHOUT CLAIM TO ANY PARTICULAR FONT, STYLE, SIZE, OR COLOR.

FOR ELECTRONIC INSTRUMENTS, NAMELY, ANALYZERS CONSISTING OF AN X-RAY SOURCE AND FLUORESCENCE DETECTOR COMPONENTS FOR DETECTING AND MEASURING THE CONCENTRATION OF SILICON IN A SAMPLE (U.S. CLS. 21, 23, 26, 36 AND 38).

FIRST USE 10-31-2011; IN COMMERCE 10-31-2011.

CLASS 9—(Continued).

4,119,172. CISCO TECHNOLOGY, INC., SAN JOSE, CA. SN 85-073,381. PUB. 12-14-2010, FILED 6-28-2010.

CISCO CIUS

THE MARK CONSISTS OF STANDARD CHARACTERS WITHOUT CLAIM TO ANY PARTICULAR FONT, STYLE, SIZE, OR COLOR.

OWNER OF U.S. REG. NOS. 3,709,076, 3,759,451, AND OTHERS.

FOR COMPUTER HARDWARE; TELEPHONES; HAND-HELD COMPUTERS; COMMUNICATIONS SOFTWARE FOR CONNECTING COMPUTER AND HAND-HELD COMPUTERS; SOFTWARE THAT FACILITATES VIDEO AND VOICE COMMUNICATIONS BETWEEN PARTIES; MOBILE ELECTRONIC DEVICES, NAMELY, CELLULAR HANDSETS AND HAND-HELD COMPUTERS FOR AUDIO AND VIDEO CONFERENCING, UTILIZING ELECTRONIC MAIL, INSTANT MESSAGING AND TRANSMITTING OTHER DIGITAL DATA; OPERATING SYSTEM PROGRAMS; DATA SYNCHRONIZATION PROGRAMS; DOCKING STATIONS (U.S. CLS. 21, 23, 26, 36 AND 38).

FIRST USE 8-31-2011; IN COMMERCE 8-31-2011.

4,119,174. EVIDON, INC., NEW YORK, NY. SN 85-073,786. PUB. 5-24-2011, FILED 6-29-2010.



THE COLOR(S) BLUE IS/ARE CLAIMED AS A FEATURE OF THE MARK.

THE MARK CONSISTS OF A BLUE GHOST DESIGN. THE COLOR WHITE REPRESENTS BACKGROUND AND IS NOT PART OF THE MARK.

FOR DOWNLOADABLE APPLICATION THAT ALLOWS USERS TO VIEW AND BLOCK THE TRACKING SETTINGS, WEB BUGS, WIDGETS AND ADVERTISING SERVICES ASSOCIATED WITH WEBSITES VISITED (U.S. CLS. 21, 23, 26, 36 AND 38).

FIRST USE 4-0-2010; IN COMMERCE 4-0-2010.

CLASS 9—(Continued).

4,119,179. TERRY L. WIKE, LAS VEGAS, NV. SN 85-075,815.
PUB. 12-7-2010, FILED 7-1-2010.

IDROP

THE MARK CONSISTS OF STANDARD CHARACTERS WITHOUT CLAIM TO ANY PARTICULAR FONT, STYLE, SIZE, OR COLOR.

FOR HANDLES AND STANDS ADAPTED FOR USE WITH PORTABLE ELECTRONIC DEVICES (U.S. CLS. 21, 23, 26, 36 AND 38).

FIRST USE 12-15-2010; IN COMMERCE 12-15-2010.

4,119,208. PROTEK ME LLC, TAMARAC, FL. SN 85-091,402.
PUB. 7-5-2011, FILED 7-23-2010.

PROTEK.ME

THE MARK CONSISTS OF STANDARD CHARACTERS WITHOUT CLAIM TO ANY PARTICULAR FONT, STYLE, SIZE, OR COLOR.

FOR RADIATION SHIELDS FOR ELECTRONIC PRODUCTS (U.S. CLS. 21, 23, 26, 36 AND 38).

FIRST USE 2-2-2011; IN COMMERCE 2-2-2011.

4,119,217. SIMON & SCHUSTER, INC., NEW YORK, NY. SN 85-097,237. PUB. 5-24-2011, FILED 7-30-2010.

SNAP IT WATCH IT

THE MARK CONSISTS OF STANDARD CHARACTERS WITHOUT CLAIM TO ANY PARTICULAR FONT, STYLE, SIZE, OR COLOR.

FOR SMARTPHONE APPLICATION FOR CONSUMERS, NAMELY, COMPUTER SOFTWARE FOR USE IN PROVIDING INFORMATION AND VIDEOS ON BOOKS, AUTHORS, AND BOOK PUBLISHING (U.S. CLS. 21, 23, 26, 36 AND 38).

FIRST USE 7-6-2010; IN COMMERCE 7-6-2010.

CLASS 9—(Continued).

4,119,241. CEM & ASSOCIATES, DBA PICOSPIN, BOULDER, CO. SN 85-118,605. PUB. 2-15-2011, FILED 8-30-2010.



THE COLOR(S) BROWN AND ORANGE IS/ARE CLAIMED AS A FEATURE OF THE MARK.

THE MARK CONSISTS OF THE STYLIZED WORDING "PICOSPIN", WITH THE LETTERING "PICO" AND THE "S", "P", AND "N" IN "SPIN" IN BROWN AND THE "I" IN "SPIN" IN ORANGE, AND A DESIGN OF FOUR ORANGE CONCENTRIC SEMI-CIRCLES BELOW ONE ANOTHER ABOVE THE "I" IN "SPIN".

FOR SCIENTIFIC APPARATUS, NAMELY, SPECTROMETERS AND PARTS AND FITTINGS THEREFOR (U.S. CLS. 21, 23, 26, 36 AND 38).

FIRST USE 4-1-2010; IN COMMERCE 6-1-2010.

4,119,254. GEORGE T. GUINANE, AKA GEORGE THOMAS, MANCHESTER, MA. SN 85-123,452. PUB. 2-22-2011, FILED 9-5-2010.

George Thomas

THE MARK CONSISTS OF STANDARD CHARACTERS WITHOUT CLAIM TO ANY PARTICULAR FONT, STYLE, SIZE, OR COLOR.

THE NAME "GEORGE THOMAS" IDENTIFIES A LIVING INDIVIDUAL WHOSE CONSENT IS OF RECORD.

FOR DIGITAL MUSIC DOWNLOADABLE FROM THE INTERNET; DIGITAL MUSIC SYSTEM THAT SYNCHRONIZES DIGITAL MUSIC FILES STORED ON A HOME UNIT AND A CAR UNIT; DIGITAL MUSIC SYSTEM THAT SYNCHRONIZES DIGITAL RADIO FILES STORED ON A HOME UNIT, A CAR UNIT, OR PORTABLE UNIT AND THAT MAY BE BACKED UP TO AN INTERNET DEPOSITORY; DIGITAL PHOTO FRAMES FOR DISPLAYING DIGITAL PICTURES, VIDEO CLIPS AND MUSIC; DOWNLOADABLE MUSICAL SOUND RECORDINGS; DOWNLOADABLE RING TONES, GRAPHICS AND MUSIC VIA A GLOBAL COMPUTER NETWORK AND WIRELESS DEVICES; DOWNLOADABLE VIDEO RECORDINGS FEATURING MUSIC; DOWNLOADABLE RING TONES VIA THE INTERNET AND WIRELESS DEVICES; ELECTRICAL VOICE INTRACOMMUNICATIONS SYSTEMS COMPRISING CONTROL STATIONS, INTERFACE MODULES, FRAMES, CONTROLLER CARDS, CONNECTORS, POWER SUPPLIES, PANELS AND MOUNTINGS FOR USE IN THE PRODUCTION OF LIVE MUSICAL PERFORMANCES, THEATRE, AND OTHER LIVE EVENTS; INTERACTIVE MUSIC MANUSCRIPT IN MULTIMEDIA VIDEO GAME FORMAT DISTRIBUTED AS DOWNLOADABLE OR DIGITAL MEDIA (U.S. CLS. 21, 23, 26, 36 AND 38).

FIRST USE 1-0-1995; IN COMMERCE 1-0-1995.

CLASS 9—(Continued).

4,119,261. LECO CORPORATION, ST. JOSEPH, MI. SN 85-130,084. PUB. 5-17-2011, FILED 9-15-2010.

CHROMATOF-HRT

THE MARK CONSISTS OF STANDARD CHARACTERS WITHOUT CLAIM TO ANY PARTICULAR FONT, STYLE, SIZE, OR COLOR.

OWNER OF U.S. REG. NO. 2,644,187.
FOR COMPUTER SOFTWARE FOR USE IN COMPUTER CONTROL OF MASS SPECTROMETERS; SCIENTIFIC AND LABORATORY INSTRUMENTS, NAMELY, ANALYTICAL INSTRUMENTS FOR DETERMINING CHEMICAL CONSTITUENTS; INSTRUMENTS AND APPARATUS FOR USE IN TESTING, CONTROL, DETECTION, MONITORING AND THE ANALYSIS OF MATERIALS IN THE NATURE OF ELEMENTS, COMBINATIONS OF ELEMENTS FROM THE PERIODIC TABLE, MOLECULAR MATERIALS, AND COMPLEX CHEMISTRIES IN SCIENTIFIC AND INDUSTRIAL OPERATIONS (U.S. CLS. 21, 23, 26, 36 AND 38).

FIRST USE 3-0-2011; IN COMMERCE 11-28-2011.

4,119,264. NEXSAN TECHNOLOGIES, THOUSAND OAKS, CA. SN 85-131,337. PUB. 3-1-2011, FILED 9-16-2010.

A Different Kind of Storage Experience

THE MARK CONSISTS OF STANDARD CHARACTERS WITHOUT CLAIM TO ANY PARTICULAR FONT, STYLE, SIZE, OR COLOR.

FOR COMPUTER HARDWARE AND DOWNLOADABLE SOFTWARE USED FOR DATA STORAGE AND DATA MANAGEMENT (U.S. CLS. 21, 23, 26, 36 AND 38).

FIRST USE 3-1-2011; IN COMMERCE 3-1-2011.

4,119,269. SOILMOISTURE EQUIPMENT CORP., GOLETA, CA. SN 85-136,050. PUB. 3-15-2011, FILED 9-22-2010.



NO CLAIM IS MADE TO THE EXCLUSIVE RIGHT TO USE "PERMEAMETER", APART FROM THE MARK AS SHOWN.

CLASS 9—(Continued).

THE MARK CONSISTS OF A STYLIZED RENDITION OF AN AARDVARK ON THE RUN AND THE WORDS "AARDVARK PERMEAMETER" IN EGYPTIAN FONT TYPE CENTERED WITHIN THE AARDVARK.

FOR INSTRUMENTS FOR MEASURING PERMEABILITY OF SOILS (U.S. CLS. 21, 23, 26, 36 AND 38).

FIRST USE 8-0-2010; IN COMMERCE 8-0-2010.

4,119,289. ORCA MD LLC, PARK CITY, UT. SN 85-149,425. PUB. 3-8-2011, FILED 10-11-2010.

FaceDecide

THE MARK CONSISTS OF STANDARD CHARACTERS WITHOUT CLAIM TO ANY PARTICULAR FONT, STYLE, SIZE, OR COLOR.

FOR DOWNLOADABLE SOFTWARE FOR PROVIDING HEALTH INFORMATION (U.S. CLS. 21, 23, 26, 36 AND 38).

FIRST USE 7-7-2011; IN COMMERCE 7-7-2011.

4,119,299. AINSWORTH GAME TECHNOLOGY, NEWINGTON, AUSTRALIA. SN 85-155,526. PUB. 5-10-2011, FILED 10-18-2010.

Enchanted World Deluxe

THE MARK CONSISTS OF STANDARD CHARACTERS WITHOUT CLAIM TO ANY PARTICULAR FONT, STYLE, SIZE, OR COLOR.

NO CLAIM IS MADE TO THE EXCLUSIVE RIGHT TO USE "DELUXE", APART FROM THE MARK AS SHOWN.

FOR COMPUTER SOFTWARE AND FIRMWARE FOR GAMES OF CHANCE ON ANY COMPUTERIZED PLATFORM, INCLUDING DEDICATED GAMING CONSOLES, VIDEO BASED SLOT MACHINES, REEL BASED SLOT MACHINES, AND VIDEO LOTTERY TERMINALS (U.S. CLS. 21, 23, 26, 36 AND 38).

FIRST USE 11-20-2011; IN COMMERCE 11-20-2011.

CLASS 9—(Continued).

4,119,300. AINSWORTH GAME TECHNOLOGY, NEWINGTON, AUSTRALIA. SN 85-155,528. PUB. 5-10-2011, FILED 10-18-2010.

Fortune Fountain Deluxe

THE MARK CONSISTS OF STANDARD CHARACTERS WITHOUT CLAIM TO ANY PARTICULAR FONT, STYLE, SIZE, OR COLOR.

NO CLAIM IS MADE TO THE EXCLUSIVE RIGHT TO USE "DELUXE", APART FROM THE MARK AS SHOWN.

FOR COMPUTER SOFTWARE AND FIRMWARE FOR GAMES OF CHANCE ON ANY COMPUTERIZED PLATFORM, INCLUDING DEDICATED GAMING CONSOLES, VIDEO BASED SLOT MACHINES, REEL BASED SLOT MACHINES, AND VIDEO LOTTERY TERMINALS (U.S. CLS. 21, 23, 26, 36 AND 38).

FIRST USE 11-15-2011; IN COMMERCE 11-15-2011.

4,119,316. INTRYCA, INC., SANTA BARBARA, CA. SN 85-170,741. PUB. 5-10-2011, FILED 11-5-2010.

CLAVEO

THE MARK CONSISTS OF STANDARD CHARACTERS WITHOUT CLAIM TO ANY PARTICULAR FONT, STYLE, SIZE, OR COLOR.

THE WORDING "CLAVEO" HAS NO MEANING IN A FOREIGN LANGUAGE.

FOR COMPUTER APPLICATION SOFTWARE FOR DESKTOPS, LAPTOPS, HANDHELD COMPUTERS, SMARTPHONES AND MOBILE PHONES, NAMELY, SOFTWARE FOR ELECTRONIC DATA SECURITY AND FOR MANAGING PASSWORDS AND ELECTRONIC FILES (U.S. CLS. 21, 23, 26, 36 AND 38).

FIRST USE 3-1-2011; IN COMMERCE 3-1-2011.

4,119,327. SHAPIRO, JORDAN MARTIN, AKA JORDAN MARTIN, PEORIA, AZ. SN 85-177,449. PUB. 6-7-2011, FILED 11-16-2010.

Jordan Martin

THE MARK CONSISTS OF STANDARD CHARACTERS WITHOUT CLAIM TO ANY PARTICULAR FONT, STYLE, SIZE, OR COLOR.

CLASS 9—(Continued).

THE NAME "JORDAN MARTIN" IDENTIFIES A LIVING INDIVIDUAL WHOSE CONSENT IS OF RECORD.

FOR AUDIO AND VIDEO RECORDINGS FEATURING MUSIC AND ARTISTIC PERFORMANCES (U.S. CLS. 21, 23, 26, 36 AND 38).

FIRST USE 8-5-2011; IN COMMERCE 8-5-2011.

4,119,332. LEGACIE ACCESSORIES LLC, NEW YORK, NY. SN 85-180,056. PUB. 4-12-2011, FILED 11-18-2010.

KATA M1

THE MARK CONSISTS OF STANDARD CHARACTERS WITHOUT CLAIM TO ANY PARTICULAR FONT, STYLE, SIZE, OR COLOR.

OWNER OF U.S. REG. NO. 1,733,979.

FOR EYEWEAR, NAMELY, EYEGLASSES AND SUNGLASSES (U.S. CLS. 21, 23, 26, 36 AND 38).

FIRST USE 3-17-2011, THE MARK WAS FIRST USED ANYWHERE IN A DIFFERENT FORM OTHER THAN THAT SOUGHT TO BE REGISTERED AT LEAST AS EARLY AS 12/19/1991. ; IN COMMERCE 3-17-2011, THE MARK WAS FIRST USED IN COMMERCE IN A DIFFERENT FORM OTHER THAN THAT SOUGHT TO BE REGISTERED AT LEAST AS EARLY AS 12/19/1991..

4,119,341. DJ ASHBA, WEST HOLLYWOOD, CA. SN 85-183,992. PUB. 4-26-2011, FILED 11-23-2010.

DJ ASHBA

THE MARK CONSISTS OF STANDARD CHARACTERS WITHOUT CLAIM TO ANY PARTICULAR FONT, STYLE, SIZE, OR COLOR.

THE NAME "DJ ASHBA" IDENTIFIES A LIVING INDIVIDUAL WHOSE CONSENT IS OF RECORD.

FOR MUSICAL SOUND RECORDINGS AND PRE-RECORDED COMPACT DISCS, AUDIO DISCS, VISUAL DISCS AND AUDIOVISUAL DISCS FEATURING MUSIC; DOWNLOADABLE RING TONES; MP3 RECORDINGS FEATURING MUSIC; FITTED VINYL FILMS KNOWN AS SKINS FOR COVERING AND PROVIDING A SCRATCH PROOF BARRIER OR PROTECTION FOR ELECTRONIC DEVICES, NAMELY, CELL PHONES, LAPTOP COMPUTERS, MP3 PLAYERS, COMPUTER GAME CONSOLES AND GUITARS; AND GUITAR AND BASS TUNER APPLICATION FOR CELL PHONES (U.S. CLS. 21, 23, 26, 36 AND 38).

FIRST USE 3-25-2008; IN COMMERCE 3-25-2008.

CLASS 9—(Continued).

4,119,347. GARDUS, INC., POWAY, CA. SN 85-185,391. PUB. 5-24-2011, FILED 11-26-2010.

LINTGARD

THE MARK CONSISTS OF STANDARD CHARACTERS WITHOUT CLAIM TO ANY PARTICULAR FONT, STYLE, SIZE, OR COLOR.

FOR DRYER SAFETY EQUIPMENT, NAMELY, DRYER SAFETY MONITORS FOR LINT BUILD UP AND VENT OBSTRUCTIONS (U.S. CLS. 21, 23, 26, 36 AND 38).

FIRST USE 7-15-2011; IN COMMERCE 7-15-2011.

4,119,359. SONY PICTURES HOME ENTERTAINMENT INC., CULVER CITY, CA. SN 85-189,344. PUB. 6-21-2011, FILED 12-2-2010.



NO CLAIM IS MADE TO THE EXCLUSIVE RIGHT TO USE "DAILY CLIP", APART FROM THE MARK AS SHOWN.

THE COLOR(S) YELLOW AND BLACK IS/ARE CLAIMED AS A FEATURE OF THE MARK.

THE MARK CONSISTS OF THE WORDS "MY DAILY CLIP" IN YELLOW WITH THE LETTER "I" IN "CLIP" DEPICTING A FILM STRIP WITH BLACK DOTS. THE ENTIRE MARK APPEARS ON A BLACK BACKGROUND, WHICH IS NOT PART OF THE MARK.

FOR COMPUTER PROGRAM FOR VIEWING PARTS OF FEATURE MOTION PICTURES AND TELEVISION SHOWS ON MULTIPLE COMPUTER AND NETWORK PLATFORMS (U.S. CLS. 21, 23, 26, 36 AND 38).

FIRST USE 3-29-2011; IN COMMERCE 3-29-2011.

CLASS 9—(Continued).

4,119,360. SONY PICTURES HOME ENTERTAINMENT INC., CULVER CITY, CA. SN 85-189,364. PUB. 6-21-2011, FILED 12-2-2010.



NO CLAIM IS MADE TO THE EXCLUSIVE RIGHT TO USE "DAILY CLIP", APART FROM THE MARK AS SHOWN.

THE COLOR(S) YELLOW, WHITE AND BLACK IS/ARE CLAIMED AS A FEATURE OF THE MARK.

THE MARK CONSISTS OF A ROUNDED SQUARE OUTLINED IN WHITE, YELLOW BACKGROUND INSIDE THE SQUARE WITH A BLACK FILM STRIP CONTAINING YELLOW RECTANGLES ON THE TOP AND BOTTOM OF THE STRIP, AND THE WORDING "MY DAILY CLIP" IN BLACK OUTLINED IN WHITE AND YELLOW WITH THE LETTER "I" IN "CLIP" DEPICTING A FILM STRIP WITH YELLOW DOTS APPEARING IN THE CENTER SQUARE PART OF THE FILM STRIP. THE ENTIRE MARK APPEARS AGAINST A BLACK BACKGROUND, WHICH IS NOT PART OF THE MARK.

FOR COMPUTER PROGRAM FOR VIEWING PARTS OF FEATURE MOTION PICTURES AND TELEVISION SHOWS ON MULTIPLE COMPUTER AND NETWORK PLATFORMS (U.S. CLS. 21, 23, 26, 36 AND 38).

FIRST USE 3-29-2011; IN COMMERCE 3-29-2011.

4,119,395. ACTIONTEC ELECTRONICS, INC., SUNNYVALE, CA. SN 85-198,857. PUB. 5-3-2011, FILED 12-15-2010.

MYWIRELESSTV

THE MARK CONSISTS OF STANDARD CHARACTERS WITHOUT CLAIM TO ANY PARTICULAR FONT, STYLE, SIZE, OR COLOR.

FOR COMPUTER HARDWARE, COMPUTER SOFTWARE, TRANSMITTERS AND RECEIVERS ALL TO FACILITATE THE TRANSMISSION OF HIGH DEFINITION CONTENT FROM ONE DEVICE TO ANOTHER DEVICE IN THE HOME (U.S. CLS. 21, 23, 26, 36 AND 38).

FIRST USE 1-4-2011; IN COMMERCE 1-0-2011.

CLASS 9—(Continued).

4,119,413. LIVING BASEBALL CARD, LLC, MUSKEGON, MI. SN 85-202,509. PUB. 5-3-2011, FILED 12-21-2010.

THE LIVING BASEBALL CARD

THE MARK CONSISTS OF STANDARD CHARACTERS WITHOUT CLAIM TO ANY PARTICULAR FONT, STYLE, SIZE, OR COLOR.
 NO CLAIM IS MADE TO THE EXCLUSIVE RIGHT TO USE "BASEBALL", APART FROM THE MARK AS SHOWN. FOR VIDEO DISKS FEATURING BASEBALL PLAYERS (U.S. CLS. 21, 23, 26, 36 AND 38).
 FIRST USE 11-21-2011; IN COMMERCE 11-21-2011.

4,119,442. CLAY BAKER, DBA WEST|280, PORTOLA VALLEY, CA. AND THOMAS RAMIES, DBA WEST|280, PORTOLA VALLEY, CA. SN 85-209,493. PUB. 8-23-2011, FILED 1-3-2011.

BevConX

THE MARK CONSISTS OF STANDARD CHARACTERS WITHOUT CLAIM TO ANY PARTICULAR FONT, STYLE, SIZE, OR COLOR.
 FOR COMPUTER SOFTWARE FOR ACCEPTING, VALIDATING, TRANSMITTING, AND PROCESSING CREDIT CARD TRANSACTIONS AND ONLINE PAYMENT TRANSACTIONS; COMPUTER SOFTWARE FOR GENERATING AND SENDING TEXT MESSAGES AND ELECTRONIC MAIL MESSAGES; COMPUTER SOFTWARE FOR DELIVERING AND PROCESSING COUPONS AND VIDEOS ON MOBILE PHONES, SMARTPHONES, AND HANDHELD COMPUTERS (U.S. CLS. 21, 23, 26, 36 AND 38).
 FIRST USE 12-31-2010; IN COMMERCE 12-31-2010.

CLASS 9—(Continued).

4,119,468. ROOT, BRIAN D., TEMPERANCE, MI. SN 85-216,121. PUB. 5-24-2011, FILED 1-12-2011.

iTr_xac

THE MARK CONSISTS OF THE WORD "ITRAC" WITH ALL LETTERS IN LOWER-CASE EXCEPT THE "T" AND HAVING THE LETTER "X" IN A LOWER POSITION THAN THE REST OF THE LETTERS.
 FOR COMPUTER APPLICATION SOFTWARE FOR MOBILE PHONES, NAMELY, SOFTWARE FOR TRACKING PHARMACEUTICAL NEEDS (U.S. CLS. 21, 23, 26, 36 AND 38).
 FIRST USE 8-4-2011; IN COMMERCE 8-4-2011.

4,119,475. WMS GAMING INC., WAUKEGAN, IL. SN 85-218,119. PUB. 4-26-2011, FILED 1-14-2011.

BARON VON BACON'S

THE MARK CONSISTS OF STANDARD CHARACTERS WITHOUT CLAIM TO ANY PARTICULAR FONT, STYLE, SIZE, OR COLOR.
 FOR COMPONENTS FOR GAMING MACHINES THAT GENERATE OR DISPLAY WAGER OUTCOMES, NAMELY, CONTROLLERS, DISPLAYS, BUTTON PANELS, BOLSTERS, ELECTRICAL WIRING, AND COMPUTER HARDWARE AND SOFTWARE ASSOCIATED THEREWITH; GAMING MACHINES, NAMELY, DEVICES WHICH ACCEPT A WAGER; GAMING SOFTWARE THAT GENERATES OR DISPLAYS WAGER OUTCOMES OF GAMING MACHINES (U.S. CLS. 21, 23, 26, 36 AND 38).
 FIRST USE 10-4-2011; IN COMMERCE 10-4-2011.

4,119,478. NINTENDO OF AMERICA INC., REDMOND, WA. SN 85-220,436. PUB. 5-31-2011, FILED 1-18-2011.

FACE RAIDERS

THE MARK CONSISTS OF STANDARD CHARACTERS WITHOUT CLAIM TO ANY PARTICULAR FONT, STYLE, SIZE, OR COLOR.
 FOR ELECTRONIC GAME PROGRAMS; ELECTRONIC GAME SOFTWARE; VIDEO GAME PROGRAMS; VIDEO GAME SOFTWARE (U.S. CLS. 21, 23, 26, 36 AND 38).
 FIRST USE 3-27-2011; IN COMMERCE 3-27-2011.

CLASS 9—(Continued).

4,119,489. IXIA, CALABASAS, CA. SN 85-221,806. PUB. 5-31-2011, FILED 1-20-2011.

XDENSITY

THE MARK CONSISTS OF STANDARD CHARACTERS WITHOUT CLAIM TO ANY PARTICULAR FONT, STYLE, SIZE, OR COLOR.

FOR COMPUTER HARDWARE AND SOFTWARE FOR SIMULATING TRAFFIC ACROSS COMMUNICATIONS NETWORKS AND TESTING AND TROUBLESHOOTING THE PERFORMANCE OF THOSE NETWORKS (U.S. CLS. 21, 23, 26, 36 AND 38).

FIRST USE 6-3-2011; IN COMMERCE 6-3-2011.

4,119,502. TIDEWORKS TECHNOLOGY, INC., SEATTLE, WA. SN 85-225,328. PUB. 5-31-2011, FILED 1-25-2011.

IPRO

THE MARK CONSISTS OF STANDARD CHARACTERS WITHOUT CLAIM TO ANY PARTICULAR FONT, STYLE, SIZE, OR COLOR.

FOR COMPUTER SOFTWARE FOR MANAGEMENT AND OPERATION OF FREIGHT AND CARGO TERMINALS, FOR TRACKING, PLANNING, LOADING, STOWING, DISCHARGING, POSITIONING AND PROCESSING FREIGHT AND CARGO (U.S. CLS. 21, 23, 26, 36 AND 38).

FIRST USE 3-31-2010; IN COMMERCE 8-3-2010.

4,119,526. POWER MONITORS, INC., MOUNT CRAWFORD, VA. SN 85-233,749. PUB. 6-14-2011, FILED 2-3-2011.

BOOMERANG

THE MARK CONSISTS OF STANDARD CHARACTERS WITHOUT CLAIM TO ANY PARTICULAR FONT, STYLE, SIZE, OR COLOR.

FOR VOLTAGE MEASUREMENT AND RECORDING EQUIPMENT AND ASSOCIATED SOFTWARE FOR USE IN RESIDENTIAL, COMMERCIAL, RETAIL, INSTITUTIONAL, INDUSTRIAL AND SUBSTATION APPLICATIONS (U.S. CLS. 21, 23, 26, 36 AND 38).

FIRST USE 6-30-2011; IN COMMERCE 6-30-2011.

CLASS 9—(Continued).

4,119,527. NATIONAL AUTOMATED CLEARING HOUSE ASSOCIATION, HERNDON, VA. SN 85-234,323. PUB. 6-14-2011, FILED 2-4-2011.

Pay·ol·o·gist

THE MARK CONSISTS OF THE WORD "PAY", FOLLOWED BY A DOT, FOLLOWED BY THE LETTERS "OL", FOLLOWED BY A DOT, FOLLOWED BY THE LETTER "O", AND FOLLOWED BY THE LETTERS "GIST".

FOR DOWNLOADABLE ELECTRONIC NEWSLETTERS IN THE FIELD OF ELECTRONIC BILLING AND PAYMENT RULES, OPTIONS, SERVICES, NETWORKS, AND RISKS (U.S. CLS. 21, 23, 26, 36 AND 38).

FIRST USE 12-29-2011; IN COMMERCE 12-29-2011.

4,119,530. WMS GAMING INC., WAUKEGAN, IL. SN 85-235,697. PUB. 4-26-2011, FILED 2-7-2011.

TEAM COMPETE TO WIN

THE MARK CONSISTS OF STANDARD CHARACTERS WITHOUT CLAIM TO ANY PARTICULAR FONT, STYLE, SIZE, OR COLOR.

OWNER OF U.S. REG. NO. 3,648,242.

FOR COMPONENTS FOR GAMING MACHINES THAT GENERATE OR DISPLAY WAGER OUTCOMES, NAMELY, CONTROLLERS, DISPLAYS, BUTTON PANELS, BOLSTERS, ELECTRICAL WIRING, AND COMPUTER HARDWARE AND SOFTWARE ASSOCIATED THEREWITH; GAMING MACHINES, NAMELY, DEVICES WHICH ACCEPT A WAGER; GAMING SOFTWARE THAT GENERATES OR DISPLAYS WAGER OUTCOMES OF GAMING MACHINES (U.S. CLS. 21, 23, 26, 36 AND 38).

FIRST USE 10-4-2011; IN COMMERCE 10-4-2011.

CLASS 9—(Continued).

4,119,542. INNOVATIVE PRODUCTS OF AMERICA, INC., WOODSTOCK, NY. SN 85-240,849. PUB. 6-21-2011, FILED 2-12-2011.

INNOVATIVE NEWS

THE MARK CONSISTS OF STANDARD CHARACTERS WITHOUT CLAIM TO ANY PARTICULAR FONT, STYLE, SIZE, OR COLOR.

FOR MOTOR VEHICLE TESTING EQUIPMENT, NAMELY, MOTOR VEHICLE ELECTRICAL SYSTEM AND BRAKING SYSTEM TESTING EQUIPMENT; TRAILER TESTING EQUIPMENT, NAMELY, TRAILER ELECTRICAL SYSTEM AND BRAKING SYSTEM TESTING EQUIPMENT; MOTOR VEHICLE TO TRAILER ELECTRICAL CONNECTORS; AND MOTOR VEHICLE TESTING EQUIPMENT, NAMELY, APPARATUS FOR INDICATING ENGINE CYLINDER POSITION (U.S. CLS. 21, 23, 26, 36 AND 38).

FIRST USE 2-15-2011; IN COMMERCE 2-15-2011.

4,119,545. NIKON CORPORATION, TOKYO, JAPAN. SN 85-241,836. PUB. 7-12-2011, FILED 2-14-2011.



THE MARK CONSISTS OF THE LETTER "P" IN THE CENTER OF AN OVAL, ABOVE AND SURROUNDED BY A STYLIZED DESIGN IN A GENERAL CIRCULAR SHAPE CONSISTING OF TWO WING-LIKE DESIGNS FRAMING VERTICAL CURVING BANDS AND TWO DIAMOND DESIGNS.

FOR RIFLESCOPES (U.S. CLS. 21, 23, 26, 36 AND 38). FIRST USE 4-26-2011; IN COMMERCE 4-26-2011.

CLASS 9—(Continued).

4,119,546. HTC CORPORATION, TAOYUAN CITY, TAIWAN. SN 85-242,055. PUB. 6-28-2011, FILED 2-14-2011.

HTC WILDFIRE S

THE MARK CONSISTS OF STANDARD CHARACTERS WITHOUT CLAIM TO ANY PARTICULAR FONT, STYLE, SIZE, OR COLOR.

OWNER OF U.S. REG. NOS. 3,532,002, 3,584,881, AND 3,636,164.

FOR COMPUTER HARDWARE AND SOFTWARE FOR ENABLING, OPERATING, ENHANCING, CUSTOMIZING, UPDATING AND MANAGING MOBILE, PORTABLE, SMART, VOICE-OVER-INTERNET-PROTOCOL, AND WIRELESS DEVICES; USER INTERFACE SOFTWARE; COMPUTER HARDWARE AND SOFTWARE FOR DELIVERING, ENABLING, CREATING, ENHANCING, CUSTOMIZING, UPDATING, AND MANAGING USER INTERFACING, TELECOMMUNICATIONS AND TELECOMMUNICATIONS SERVICES; COMPUTER HARDWARE AND SOFTWARE FOR TRANSMITTING AND RECEIVING VOICE, IMAGE, DATA, AUDIO, VIDEO AND MULTIMEDIA CONTENT; WIRELESS MODEMS; ACCESSORIES FOR THE ABOVE GOODS, NAMELY, HEADSETS, HEADSETS WITH WIRELESS TRANSMISSION FUNCTION, CONNECTION CABLES, IN-CAR TELEPHONE HANDSET CRADLES, IN-CAR MOUNTS AND FACE PLATES FOR MOBILE PHONES, SMARTPHONES, CELLULAR PHONES, PORTABLE COMPUTERS AND PERSONAL DIGITAL ASSISTANTS, REPLACEMENT PARTS THEREFORE, BATTERIES, BATTERY CHARGER ADAPTORS, BATTERY CHARGERS, CASES, POUCHES SPECIFICALLY ADAPTED FOR CARRYING MOBILE PHONES, SMARTPHONES, CELLULAR PHONES AND PERSONAL DIGITAL ASSISTANTS, IN-VEHICLE BATTERY CHARGERS, IN-VEHICLE HOLDERS (U.S. CLS. 21, 23, 26, 36 AND 38).

FIRST USE 8-3-2011; IN COMMERCE 8-3-2011.

4,119,547. APPLIED FIRE TECHNOLOGIES, LLC, COPPELL, TX. SN 85-242,930. PUB. 6-21-2011, FILED 2-15-2011.

THERMALINK

THE MARK CONSISTS OF STANDARD CHARACTERS WITHOUT CLAIM TO ANY PARTICULAR FONT, STYLE, SIZE, OR COLOR.

FOR FIRE ALARMS (U.S. CLS. 21, 23, 26, 36 AND 38). FIRST USE 11-22-2011; IN COMMERCE 11-22-2011.

CLASS 9—(Continued).

4,119,551. CADILLAC JACK, INC., DULUTH, GA. SN 85-244,909. PUB. 6-28-2011, FILED 2-17-2011.

HOT FASHION

THE MARK CONSISTS OF STANDARD CHARACTERS WITHOUT CLAIM TO ANY PARTICULAR FONT, STYLE, SIZE, OR COLOR.

FOR GAMING DEVICES, NAMELY, GAMING MACHINES, SLOT MACHINES, BINGO MACHINES, WITH OR WITHOUT VIDEO OUTPUT (U.S. CLS. 21, 23, 26, 36 AND 38).

FIRST USE 10-10-2011; IN COMMERCE 10-10-2011.

4,119,559. BEYOND THE BEAUTY, NORTH HOLLYWOOD, CA. SN 85-249,852. PUB. 7-5-2011, FILED 2-23-2011.

Beyond the Beauty

THE MARK CONSISTS OF STANDARD CHARACTERS WITHOUT CLAIM TO ANY PARTICULAR FONT, STYLE, SIZE, OR COLOR.

FOR ELECTRIC HAIR CURLING IRONS; ELECTRIC HAIR STRAIGHTENING IRONS (U.S. CLS. 21, 23, 26, 36 AND 38).

FIRST USE 10-30-2011; IN COMMERCE 12-6-2011.

4,119,562. ZHANG, PAUL, TA PDS ENTERPRISE INC., GARDENA, CA. SN 85-251,202. PUB. 9-27-2011, FILED 2-24-2011.



NO CLAIM IS MADE TO THE EXCLUSIVE RIGHT TO USE "FLASHINGBOARDS", APART FROM THE MARK AS SHOWN.

THE COLOR(S) DEEP PURPLE, LIGHT PURPLE, ORANGE, APRICOT, DARK GREEN, LIGHT GREEN, SKY BLUE, NAVY BLUE, LIGHT GREY, DEEP GREY, PURPLE, PINK, YELLOW, AND GREEN IS/ARE CLAIMED AS A FEATURE OF THE MARK.

THE MARK CONSISTS OF FOUR RIBBONS, IN THE COLORS DEEP PURPLE FADING TO LIGHT PURPLE EDGES, ORANGE LIGHTENING TO APRICOT EDGED BY ORANGE, DARK GREEN FADING TO LIGHT GREEN EDGED BY DARK GREEN, AND SKY BLUE DARKENING TO NAVY BLUE EDGED BY NAVY BLUE, WITH THE NEGATIVE SPACE AT THE CENTER OF THE FOUR RIBBONS FORMING THE SHAPE OF A FOUR-ANGLED STAR; TO THE RIGHT OF THIS RIBBON AND STAR DESIGN IS THE WORDING "FLASHINGBOARDS" ALL IN

CLASS 9—(Continued).

SMALL LETTERS WITHOUT ANY SPACES BETWEEN THE LETTERS; ALL LETTERS HAVING ITALIC SHADOWS TOWARDS UPPER LEFT IN LIGHT GREY DARKENING TO DEEP GREY AND FROM LEFT TO RIGHT THE LETTERS BEING IN THE COLORS PURPLE BLENDING TO PINK BLENDING TO ORANGE BLENDING TO YELLOW BLENDING TO LIGHT GREEN BLENDING TO GREEN BLENDING TO DARK GREEN BLENDING TO NAVY BLUE; THE COLOR WHITE IS NOT PART OF THE MARK AND REPRESENTS THE BACKGROUND.

FOR ELECTRONIC LED SIGNS (U.S. CLS. 21, 23, 26, 36 AND 38).

FIRST USE 1-10-2010; IN COMMERCE 1-10-2010.

4,119,563. PICOKINETIX, PORTLAND, OR. SN 85-252,349. PUB. 7-19-2011, FILED 2-25-2011.

picokinetix

THE MARK CONSISTS OF STANDARD CHARACTERS WITHOUT CLAIM TO ANY PARTICULAR FONT, STYLE, SIZE, OR COLOR.

FOR ELECTRIC OR ELECTRONIC SENSORS FOR VIBRATION AND FREQUENCY; FIBER OPTIC INSTRUMENTS, NAMELY, SENSING DEVICE; PHOTOELECTRIC SENSORS (U.S. CLS. 21, 23, 26, 36 AND 38).

FIRST USE 2-2-2011; IN COMMERCE 12-6-2011.

4,119,566. ABL SA, LUXEMBOURG, LUXEMBOURG. SN 85-254,197. PUB. 7-19-2011, FILED 3-1-2011.

DEEPCHEK

THE MARK CONSISTS OF STANDARD CHARACTERS WITHOUT CLAIM TO ANY PARTICULAR FONT, STYLE, SIZE, OR COLOR.

FOR SOFTWARE FOR STORAGE, MANAGEMENT, ANALYSIS, AND SUBTYPING OF DNA SEQUENCES GENERATED BY DNA SEQUENCERS (U.S. CLS. 21, 23, 26, 36 AND 38).

FIRST USE 6-12-2011; IN COMMERCE 6-12-2011.

CLASS 9—(Continued).

4,119,571. CAANES, LLC, ALBUQUERQUE, NM. SN 85-257,294. PUB. 7-19-2011, FILED 3-3-2011.

BAKE

THE MARK CONSISTS OF STANDARD CHARACTERS WITHOUT CLAIM TO ANY PARTICULAR FONT, STYLE, SIZE, OR COLOR.

FOR COMPUTER SOFTWARE ALLOWING REAL-TIME MONITORING OF GLOBAL COMPUTER NETWORKS TO DETECT MALICIOUS CONTENT; SOFTWARE ALLOWING OPERATORS TO PERFORM ANALYSIS TO GAIN KNOWLEDGE, TOPOLOGY OF NETWORKS, HIDDEN NODES, THREATS, INTENT, AND CAPABILITIES; SOFTWARE THAT HAS CLUSTER AND INSTANCE BASED LEARNING TECHNIQUES INBUILT TO PREDICT ACTIVITIES INVOLVED WITH MALICIOUS NETWORKS (U.S. CLS. 21, 23, 26, 36 AND 38).

FIRST USE 12-1-2011; IN COMMERCE 12-1-2011.

4,119,572. HTC CORPORATION, TAOYUAN CITY, TAIWAN. SN 85-257,628. PUB. 7-5-2011, FILED 3-3-2011.

HTC EVO VIEW 4G

THE MARK CONSISTS OF STANDARD CHARACTERS WITHOUT CLAIM TO ANY PARTICULAR FONT, STYLE, SIZE, OR COLOR.

OWNER OF U.S. REG. NOS. 3,532,002, 3,636,164, AND OTHERS.

FOR COMPUTER HARDWARE AND SOFTWARE FOR ENABLING, OPERATING, ENHANCING, CUSTOMIZING, UPDATING AND MANAGING MOBILE, PORTABLE, SMART, VOICE-OVER-INTERNET-PROTOCOL, AND WIRELESS DEVICES; USER INTERFACE SOFTWARE; COMPUTER HARDWARE AND SOFTWARE FOR DELIVERING, ENABLING, CREATING, ENHANCING, CUSTOMIZING, UPDATING, AND MANAGING USER INTERFACING, TELECOMMUNICATIONS AND TELECOMMUNICATIONS SERVICES; COMPUTER HARDWARE AND SOFTWARE FOR TRANSMITTING AND RECEIVING VOICE, IMAGE, DATA, AUDIO, VIDEO AND MULTIMEDIA CONTENT; WIRELESS MODEMS; ACCESSORIES FOR THE ABOVE GOODS, NAMELY, HEADSETS, HEADSETS WITH WIRELESS TRANSMISSION FUNCTION, CONNECTION CABLES, IN-CAR TELEPHONE HANDSET CRADLES, IN-CAR MOUNTS AND FACE PLATES FOR PORTABLE COMPUTERS AND PERSONAL DIGITAL ASSISTANTS, REPLACEMENT PARTS THEREFORE, BATTERIES, BATTERY CHARGER ADAPTORS, BATTERY CHARGERS, CASES, POUCHES SPECIFICALLY ADAPTED FOR CARRYING PERSONAL DIGITAL ASSISTANTS, IN-VEHICLE BATTERY CHARGERS, IN-VEHICLE HOLDERS (U.S. CLS. 21, 23, 26, 36 AND 38).

FIRST USE 6-30-2011; IN COMMERCE 6-30-2011.

CLASS 9—(Continued).

4,119,590. IMMUNO CONCEPTS N.A., LTD, DALLAS, TX. SN 85-265,520. PUB. 10-25-2011, FILED 3-12-2011.

IMAGE NAVIGATOR

THE MARK CONSISTS OF STANDARD CHARACTERS WITHOUT CLAIM TO ANY PARTICULAR FONT, STYLE, SIZE, OR COLOR.

NO CLAIM IS MADE TO THE EXCLUSIVE RIGHT TO USE "IMAGE", APART FROM THE MARK AS SHOWN.

FOR MICROSCOPES; AUTOMATED ACCESSORIES IN THE NATURE OF COMPUTER HARDWARE AND COMPUTER MONITORS, BAR CODE READERS AND SCANNERS; DIGITAL CAMERAS AND AUTOMATED MOTION CONTROL SYSTEMS FOR USE WITH MICROSCOPES, NAMELY, MOTORIZED STAGES AND AUTO-FOCUS SYSTEMS; MEDICAL SOFTWARE FOR GENERATING, PROCESSING, ANALYZING, STORING AND ARCHIVING IMAGES AND DIAGNOSTIC LABORATORY INFORMATION (U.S. CLS. 21, 23, 26, 36 AND 38).

FIRST USE 6-27-2011; IN COMMERCE 6-27-2011.

4,119,594. DAYMEN CANADA ACQUISITION ULC, VANCOUVER, BC, CANADA. SN 85-267,766. PUB. 7-12-2011, FILED 3-15-2011.

PRO ROLLER LITE

THE MARK CONSISTS OF STANDARD CHARACTERS WITHOUT CLAIM TO ANY PARTICULAR FONT, STYLE, SIZE, OR COLOR.

NO CLAIM IS MADE TO THE EXCLUSIVE RIGHT TO USE "ROLLER LITE", APART FROM THE MARK AS SHOWN.

FOR BAGS, MESSENGER BAGS, TOTE BAGS, HARD AND SOFT COVERED CASES, BACKPACKS WITH ROLLING WHEELS, BACKPACKS WITHOUT ROLLING WHEELS, SHOULDER BAGS, MESSENGER BAGS AND POUCHES, ALL DESIGNED FOR CARRYING PHOTOGRAPHIC, CINEMATOGRAPHIC, VIDEOGRAPHIC, OPTICAL, AUDIO, COMPUTER AND ELECTRONIC EQUIPMENT (U.S. CLS. 21, 23, 26, 36 AND 38).

FIRST USE 10-21-2011; IN COMMERCE 10-21-2011.

CLASS 9—(Continued).

4,119,596. PAKSENSE, INC., BOISE, ID. SN 85-268,971. PUB. 8-2-2011, FILED 3-16-2011.

XPRESSPDF

THE MARK CONSISTS OF STANDARD CHARACTERS WITHOUT CLAIM TO ANY PARTICULAR FONT, STYLE, SIZE, OR COLOR.

FOR ENCODED ELECTRONIC CHIP CARDS CONTAINING PROGRAMMING USED TO MONITOR, RECORD, AND REPORT THE ENVIRONMENTAL STATUS AND FRESHNESS OF PRODUCTS; ENCODED ELECTRONIC CHIP CARDS FOR MONITOR, RECORD, AND REPORT THE ENVIRONMENTAL STATUS AND FRESHNESS OF PRODUCTS; ENCODED SMART CARDS CONTAINING PROGRAMMING USED TO MONITOR, RECORD, AND REPORT THE ENVIRONMENTAL STATUS AND FRESHNESS OF PRODUCTS (U.S. CLS. 21, 23, 26, 36 AND 38).

FIRST USE 12-16-2011; IN COMMERCE 12-16-2011.

4,119,613. T-MOBILE USA, INC., BELLEVUE, WA. SN 85-279,647. PUB. 10-25-2011, FILED 3-29-2011.

SONIC

THE MARK CONSISTS OF STANDARD CHARACTERS WITHOUT CLAIM TO ANY PARTICULAR FONT, STYLE, SIZE, OR COLOR.

FOR WIRELESS ROUTERS AND WIRELESS ACCESS POINTS (U.S. CLS. 21, 23, 26, 36 AND 38).

FIRST USE 10-19-2011; IN COMMERCE 10-19-2011.

4,119,615. SHANGHAI EBEST COMMUNICATION & TECHNOLOGY CO., LTD., SHANGHAI CITY, CHINA. SN 85-281,890. PUB. 8-9-2011, FILED 3-30-2011.

EBEST

THE MARK CONSISTS OF THE STYLIZED WORD "EBEST".

CLASS 9—(Continued).

THE WORDING "EBEST" HAS NO MEANING IN A FOREIGN LANGUAGE.

FOR ALARM INSTALLATIONS AND ALARMS; AMUSEMENT APPARATUS ADAPTED FOR USE WITH AN EXTERNAL DISPLAY SCREEN OR MONITOR; BATTERY CHARGERS; CAMERAS; DATA PROCESSORS; DOWNLOADABLE ELECTRONIC DICTIONARIES; ELECTRONIC NOTICE BOARDS; OPTICAL DISC PLAYERS; REMOTE CONTROLS FOR RADIOS, TELEVISIONS, STEREOS; TELEPHONE APPARATUS (U.S. CLS. 21, 23, 26, 36 AND 38).

FIRST USE 8-21-2005; IN COMMERCE 4-3-2011.

4,119,624. SCRAPROOM, LLC, GAINESVILLE, GA. SN 85-289,402. PUB. 9-13-2011, FILED 4-7-2011.

ScrapRoom

THE MARK CONSISTS OF STANDARD CHARACTERS WITHOUT CLAIM TO ANY PARTICULAR FONT, STYLE, SIZE, OR COLOR.

FOR COMPUTER SOFTWARE FOR ORGANIZING, CATALOGING, VIEWING, EDITING, TAGGING, AND CREATING DIGITAL PROJECTS FROM DIGITAL PHOTOS AND DESIGN ELEMENTS OR IMAGES (U.S. CLS. 21, 23, 26, 36 AND 38).

FIRST USE 5-9-2011; IN COMMERCE 5-9-2011.

4,119,625. MAYE, RICHARD WARREN ADAMFO, AKA WILL AMAZE, BRONX, NY. SN 85-289,777. PUB. 8-16-2011, FILED 4-8-2011.

Will Amaze

THE MARK CONSISTS OF STANDARD CHARACTERS WITHOUT CLAIM TO ANY PARTICULAR FONT, STYLE, SIZE, OR COLOR.

THE NAME "WILL AMAZE" IDENTIFIES A LIVING INDIVIDUAL WHOSE CONSENT IS OF RECORD.

FOR AUDIO AND VIDEO RECORDINGS FEATURING MUSIC AND ARTISTIC PERFORMANCES; DIGITAL MUSIC DOWNLOADABLE FROM THE INTERNET; DOWNLOADABLE MP3 FILES, MP3 RECORDINGS, ON-LINE DISCUSSION BOARDS, WEBCASTS, WEBINARS AND PODCASTS FEATURING MUSIC, AUDIO BOOKS IN THE FIELD OF MUSIC, AND NEWS BROADCASTS; DOWNLOADABLE MUSICAL SOUND RECORDINGS; DOWNLOADABLE RING TONES, GRAPHICS AND MUSIC VIA A GLOBAL COMPUTER NETWORK AND WIRELESS DEVICES; MUSICAL RECORDINGS; MUSICAL SOUND RECORDINGS; MUSICAL VIDEO RECORDINGS (U.S. CLS. 21, 23, 26, 36 AND 38).

FIRST USE 7-13-2011; IN COMMERCE 7-13-2011.

CLASS 9—(Continued).

4,119,629. TR THEATER RESEARCH, INC., CYPRESS, CA. SN 85-292,068. PUB. 8-23-2011, FILED 4-11-2011.

SKYLINE MULTIMEDIA

THE MARK CONSISTS OF STANDARD CHARACTERS WITHOUT CLAIM TO ANY PARTICULAR FONT, STYLE, SIZE, OR COLOR.

NO CLAIM IS MADE TO THE EXCLUSIVE RIGHT TO USE "MULTIMEDIA", APART FROM THE MARK AS SHOWN.

FOR AUDIO SPEAKERS; MULTIMEDIA PROJECTORS; VIDEO PROJECTORS (U.S. CLS. 21, 23, 26, 36 AND 38).

FIRST USE 1-4-2012; IN COMMERCE 1-4-2012.



4,119,635. BRYAN FAMILY ENTERPRISES LLC, UNION CITY, CA. SN 85-294,954. PUB. 9-6-2011, FILED 4-14-2011.

Da Brim

THE MARK CONSISTS OF STANDARD CHARACTERS WITHOUT CLAIM TO ANY PARTICULAR FONT, STYLE, SIZE, OR COLOR.

NO CLAIM IS MADE TO THE EXCLUSIVE RIGHT TO USE "BRIM", APART FROM THE MARK AS SHOWN.

FOR SPORTS HELMETS ACCESSORIES, NAMELY, DETACHABLE BRIMS, SUNSHADES, AND VISORS FOR USE WITH SPORTS HELMETS (U.S. CLS. 21, 23, 26, 36 AND 38).

FIRST USE 1-10-2012; IN COMMERCE 1-10-2012.



4,119,648. INNOVATIVE CONTROL SYSTEMS, INC., WIND GAP, PA. SN 85-299,801. PUB. 9-6-2011, FILED 4-20-2011.

WashConnect

THE MARK CONSISTS OF STANDARD CHARACTERS WITHOUT CLAIM TO ANY PARTICULAR FONT, STYLE, SIZE, OR COLOR.

FOR COMPUTER SOFTWARE FOR CONSOLIDATING AND REPORTING CAR WASH DATA VIA THE INTERNET (U.S. CLS. 21, 23, 26, 36 AND 38).

FIRST USE 5-1-2011; IN COMMERCE 5-1-2011.

CLASS 9—(Continued).

4,119,653. DAISYWORKS, INC., ROCHESTER, NY. SN 85-303,011. PUB. 9-27-2011, FILED 4-23-2011.

Internet Your Thing

THE MARK CONSISTS OF STANDARD CHARACTERS WITHOUT CLAIM TO ANY PARTICULAR FONT, STYLE, SIZE, OR COLOR.

NO CLAIM IS MADE TO THE EXCLUSIVE RIGHT TO USE "INTERNET", APART FROM THE MARK AS SHOWN.

FOR COMPUTER HARDWARE COMPRISED OF WIRED AND WIRELESS MICROCONTROLLERS, AND ACCOMPANYING SOFTWARE, THAT CONNECTS TO SENSORS AND ELECTRONIC CONTROLS TO ALLOW FOR AUTOMATED AND MANUAL CONFIGURATION AND INTERACTION WITH DATA, EVENTS, AND ALARMS, EITHER LOCALLY OR REMOTELY (U.S. CLS. 21, 23, 26, 36 AND 38).

FIRST USE 10-1-2011; IN COMMERCE 1-1-2012.



4,119,708. BRIGGS MEDICAL SERVICE COMPANY, WEST DES MOINES, IA. SN 85-351,267. PUB. 11-1-2011, FILED 6-21-2011.

SAFE STEP

THE MARK CONSISTS OF STANDARD CHARACTERS WITHOUT CLAIM TO ANY PARTICULAR FONT, STYLE, SIZE, OR COLOR.

FOR MOTION SENSITIVE SECURITY LIGHTS (U.S. CLS. 21, 23, 26, 36 AND 38).

FIRST USE 10-1-2011; IN COMMERCE 10-1-2011.



4,119,719. NEXTMEDIA OPERATING, INC., GREENWOOD VILLAGE, CO. SN 85-975,489. PUB. 10-26-2010, FILED 5-25-2010.

ROCKETGRAB

THE MARK CONSISTS OF STANDARD CHARACTERS WITHOUT CLAIM TO ANY PARTICULAR FONT, STYLE, SIZE, OR COLOR.

FOR CONSUMER COUPONS DOWNLOADED FROM A GLOBAL COMPUTER NETWORK (U.S. CLS. 21, 23, 26, 36 AND 38).

FIRST USE 2-28-2011; IN COMMERCE 2-28-2011.

CLASS 9—(Continued).

4,119,735. C. WONDER LLC, NEW YORK, NY. SN 85-976,279.
PUB. 8-2-2011, FILED 4-4-2011.



THE MARK CONSISTS OF A STYLIZED LETTER "C".
FOR EYEWEAR, NAMELY, SUNGLASSES, EYE-
GLASSES AND OPHTHALMIC FRAMES AND CASES
THEREFOR; ELECTRONICS, NAMELY, CELL PHONE
CASES, AND AUDIO HEADPHONES (U.S. CLS. 21, 23,
26, 36 AND 38).
FIRST USE 10-22-2011; IN COMMERCE 10-22-2011.

CLASS 10—MEDICAL APPARATUS

4,118,832. GLOBUS MEDICAL, INC., AUDUBON, PA. SN 77-
466,619. PUB. 9-23-2008, FILED 5-6-2008.

SOFTSTOP

THE MARK CONSISTS OF STANDARD CHARACTERS
WITHOUT CLAIM TO ANY PARTICULAR FONT, STYLE,
SIZE, OR COLOR.
FOR SPINAL IMPLANTS FOR USE IN SPINE SUR-
GERY CONSISTING OF ARTIFICIAL MATERIAL (U.S.
CLS. 26, 39 AND 44).
FIRST USE 2-23-2009; IN COMMERCE 2-23-2009.

CLASS 10—(Continued).

4,118,867. MEDTRONIC, INC., MINNEAPOLIS, MN. SN 77-
545,592. PUB. 11-11-2008, FILED 8-13-2008.

BALANCE

THE MARK CONSISTS OF STANDARD CHARACTERS
WITHOUT CLAIM TO ANY PARTICULAR FONT, STYLE,
SIZE, OR COLOR.
FOR BIOCOMPATIBLE SURFACE COATINGS SOLD
AS AN INTEGRAL COMPONENT OF SURGICAL AND
MEDICAL APPARATUS AND INSTRUMENTS,
NAMELY, BLOOD OXYGENATORS, RESERVOIRS
AND PUMPS (U.S. CLS. 26, 39 AND 44).
FIRST USE 7-30-2010; IN COMMERCE 7-30-2010.

4,118,991. NEUROLOGICA CORP., DANVERS, MA. SN 77-
907,699. PUB. 6-22-2010, FILED 1-8-2010.

BODYTOM

THE MARK CONSISTS OF STANDARD CHARACTERS
WITHOUT CLAIM TO ANY PARTICULAR FONT, STYLE,
SIZE, OR COLOR.
FOR MEDICAL IMAGING MACHINE, NAMELY,
COMPUTED TOMOGRAPHY (CT) APPARATUS AND
MEDICAL APPARATUS AND INSTRUMENTS FOR
USE IN POSITRON EMISSION TOMOGRAPHY (PET)
IMAGING; COMPUTER SOFTWARE FOR ENHANCING
IMAGES GENERATED BY A MEDICAL IMAGING
MACHINE (U.S. CLS. 26, 39 AND 44).
FIRST USE 12-20-2011; IN COMMERCE 12-20-2011.

4,119,010. ASAHI KASEI KURARAY MEDICAL CO. LTD.,
TOKYO 101-8101, JAPAN. SN 77-921,462. PUB. 9-7-2010,
FILED 1-27-2010.

MYSORBA

THE MARK CONSISTS OF STANDARD CHARACTERS
WITHOUT CLAIM TO ANY PARTICULAR FONT, STYLE,
SIZE, OR COLOR.
FOR MEDICAL APPARATUS OR MEDICAL INSTRU-
MENTS FOR BLOOD PURIFICATION; MEDICAL IN-
STRUMENTS, NAMELY, ADSORBENT COLUMNS FOR
BLOOD PURIFICATION, ADSORBENT COLUMNS FOR
REMOVAL OF TOXIC SUBSTANCES FROM BLOOD OR
PLASMA AND ADSORBENT COLUMNS FOR REMOVAL
OF IMMUNE SUBSTANCES FROM BLOOD OR PLASMA
(U.S. CLS. 26, 39 AND 44).
FIRST USE 3-18-2011; IN COMMERCE 3-18-2011.

CLASS 10—(Continued).

4,119,063. BOSTON SCIENTIFIC NEUROMODULATION CORPORATION, VALENCIA, CA. SN 85-001,139. PUB. 12-21-2010, FILED 3-29-2010.

CLIK

THE MARK CONSISTS OF STANDARD CHARACTERS WITHOUT CLAIM TO ANY PARTICULAR FONT, STYLE, SIZE, OR COLOR.

FOR MEDICAL IMPLANTS, NAMELY, IMPLANTABLE LEAD ANCHORS FOR IMPLANTABLE NEUROSTIMULATION LEADS (U.S. CLS. 26, 39 AND 44).
FIRST USE 7-2-2010; IN COMMERCE 7-2-2010.

4,119,083. VIACYTE, INC., SAN DIEGO, CA. SN 85-021,203. PUB. 9-7-2010, FILED 4-22-2010.

ENCAPTRA

THE MARK CONSISTS OF STANDARD CHARACTERS WITHOUT CLAIM TO ANY PARTICULAR FONT, STYLE, SIZE, OR COLOR.

FOR DRUG DELIVERY SYSTEMS (U.S. CLS. 26, 39 AND 44).
FIRST USE 1-19-2012; IN COMMERCE 1-19-2012.

4,119,186. MOTION THERAPEUTICS, INC., SAN FRANCISCO, CA. SN 85-079,962. PUB. 6-21-2011, FILED 7-8-2010.

BBTW

THE MARK CONSISTS OF STANDARD CHARACTERS WITHOUT CLAIM TO ANY PARTICULAR FONT, STYLE, SIZE, OR COLOR.

FOR MEDICAL APPAREL IN THE NATURE OF A WEIGHTED GARMENT, NAMELY, VESTS, BELTS, AND HEAD PIECES FOR USE IN EVALUATING AND TREATING BALANCE AND MOBILITY IMPAIRMENT AND NEUROLOGICAL DISORDERS (U.S. CLS. 26, 39 AND 44).
FIRST USE 9-24-2010; IN COMMERCE 9-24-2010.

CLASS 10—(Continued).

4,119,187. MOTION THERAPEUTICS, INC., SAN FRANCISCO, CA. SN 85-079,964. PUB. 6-21-2011, FILED 7-8-2010.

BALANCEWEAR

THE MARK CONSISTS OF STANDARD CHARACTERS WITHOUT CLAIM TO ANY PARTICULAR FONT, STYLE, SIZE, OR COLOR.

FOR MEDICAL APPAREL IN THE NATURE OF A WEIGHTED GARMENT, NAMELY, VESTS, BELTS, AND HEAD PIECES FOR USE IN EVALUATING AND TREATING BALANCE AND MOBILITY IMPAIRMENT AND NEUROLOGICAL DISORDERS (U.S. CLS. 26, 39 AND 44).
FIRST USE 9-24-2010; IN COMMERCE 9-24-2010.

4,119,188. MOTION THERAPEUTICS, INC., SAN FRANCISCO, CA. SN 85-079,966. PUB. 6-21-2011, FILED 7-8-2010.

THE MIND-BODY CORRECTION

THE MARK CONSISTS OF STANDARD CHARACTERS WITHOUT CLAIM TO ANY PARTICULAR FONT, STYLE, SIZE, OR COLOR.

FOR MEDICAL APPAREL IN THE NATURE OF A WEIGHTED GARMENT, NAMELY, VESTS, BELTS, AND HEAD PIECES FOR USE IN EVALUATING AND TREATING BALANCE AND MOBILITY IMPAIRMENT AND NEUROLOGICAL DISORDERS (U.S. CLS. 26, 39 AND 44).
FIRST USE 9-24-2010; IN COMMERCE 9-24-2010.

4,119,196. BAUSCH & LOMB INCORPORATED, ROCHESTER, NY. SN 85-086,174. PUB. 11-23-2010, FILED 7-16-2010.

CAPSULEGUARD

THE MARK CONSISTS OF STANDARD CHARACTERS WITHOUT CLAIM TO ANY PARTICULAR FONT, STYLE, SIZE, OR COLOR.

FOR OPHTHALMIC SURGICAL INSTRUMENTS AND DEVICES USED IN PERFORMING OPHTHALMIC SURGICAL PROCEDURES AND COMPONENT PARTS THEREOF, NAMELY, HAND HELD OPHTHALMIC, SURGICAL INSTRUMENTS (U.S. CLS. 26, 39 AND 44).
FIRST USE 7-0-2010; IN COMMERCE 7-0-2010.

CLASS 10—(Continued).

4,119,229. ZEST IP HOLDINGS LLC, ESCONDIDO, CA. SN 85-105,122. PUB. 10-11-2011, FILED 8-11-2010.

SATURNO

THE MARK CONSISTS OF STANDARD CHARACTERS WITHOUT CLAIM TO ANY PARTICULAR FONT, STYLE, SIZE, OR COLOR.

THE WORDING "SATURNO" HAS NO MEANING IN A FOREIGN LANGUAGE.

FOR DENTAL IMPLANTS AND ATTACHMENTS, NAMELY, ROOT ATTACHMENTS, OVERDENTURE ATTACHMENTS, IMPLANTS AND ANCHORS, IMPLANT ATTACHMENTS, DENTAL INSTRUMENTS FOR USE IN PERIODONTAL SURGERY IN CONNECTION WITH DENTAL IMPLANTS AND ATTACHMENTS; DENTAL IMPLANT PARTS, NAMELY, DENTAL ABUTMENTS AND DENTAL BARS (U.S. CLS. 26, 39 AND 44).

FIRST USE 10-0-2010; IN COMMERCE 10-1-2010.

CLASS 10—(Continued).

4,119,323. MDT MICRO DIAMOND TECHNOLOGIES LTD, AFULA, ISRAEL. SN 85-176,387. PUB. 9-20-2011, FILED 11-15-2010.



THE MARK CONSISTS OF A SLANTED DEPICTION OF A DENTAL BURR COMPRISED OF A CYLINDER AND A TRIANGLE HAVING A CURVED BAND SPANNING FROM THE TRIANGLE TO THE CYLINDER ON THE END OF WHICH IS A SPHERE; UNDERNEATH IS THE WORD "SAFESHANK".

FOR DENTAL BURRS; DENTAL INSTRUMENTS, NAMELY, FRICTION GRIP DIAMOND BURRS (U.S. CLS. 26, 39 AND 44).

FIRST USE 3-20-2011; IN COMMERCE 3-20-2011.

4,119,246. GLAXOSMITHKLINE LLC, WILMINGTON, DE. SN 85-120,744. PUB. 11-30-2010, FILED 9-1-2010.

IT'S YOUR RIGHT TO BREATHE RIGHT

THE MARK CONSISTS OF STANDARD CHARACTERS WITHOUT CLAIM TO ANY PARTICULAR FONT, STYLE, SIZE, OR COLOR.

OWNER OF U.S. REG. NOS. 3,258,606 AND 3,764,206.
FOR EXTERNAL NASAL DILATORS (U.S. CLS. 26, 39 AND 44).

FIRST USE 10-1-2011; IN COMMERCE 10-1-2011.

4,119,353. SUN NUCLEAR CORP., MELBOURNE, FL. SN 85-188,155. PUB. 11-8-2011, FILED 12-1-2010.

SUNPOINT

THE MARK CONSISTS OF STANDARD CHARACTERS WITHOUT CLAIM TO ANY PARTICULAR FONT, STYLE, SIZE, OR COLOR.

FOR SILICONE DIODES FOR USE IN ELECTRONIC MEASUREMENT OF RADIATION DOSE AND DOSE DISTRIBUTIONS INCORPORATED INTO MEDICAL INSTRUMENTS (U.S. CLS. 26, 39 AND 44).

FIRST USE 1-1-2010; IN COMMERCE 1-1-2010.

4,119,250. CALOGERO HOLDINGS COMPANY, INC., CARLSBAD, CA. SN 85-122,295. PUB. 2-15-2011, FILED 9-2-2010.

GRAND SEQUOIA LIFE

THE MARK CONSISTS OF STANDARD CHARACTERS WITHOUT CLAIM TO ANY PARTICULAR FONT, STYLE, SIZE, OR COLOR.

FOR MEDICAL WEARING APPAREL, NAMELY, SCRUB TOPS AND PANTS (U.S. CLS. 26, 39 AND 44).

FIRST USE 0-0-2011; IN COMMERCE 0-0-2011.

4,119,354. ACE SURGICAL SUPPLY CO., INC., BROCKTON, MA. SN 85-188,610. PUB. 5-17-2011, FILED 12-1-2010.

miniMARK

THE MARK CONSISTS OF STANDARD CHARACTERS WITHOUT CLAIM TO ANY PARTICULAR FONT, STYLE, SIZE, OR COLOR.

FOR DENTAL IMPLANTS (U.S. CLS. 26, 39 AND 44).

FIRST USE 2-19-2011; IN COMMERCE 2-19-2011.

CLASS 10—(Continued).

4,119,383. ARTHROSURFACE INCORPORATED, FRANKLIN, MA. SN 85-197,321. PUB. 5-10-2011, FILED 12-14-2010.

HemiCAP^{OVO}

OWNER OF U.S. REG. NO. 3,039,890.
THE MARK CONSISTS OF THE WORD "HEMICAP" WITH THE LETTERS "EMI" IN LOWER CASE AND THE LETTERS "H" AND "CAP" IN UPPER CASE; FOLLOWED BY THE LETTERS "OVO" IN UPPER CASE AND SUPERSCRIPIT. FOR PROSTHETIC IMPLANTS FOR ARTICULAR RESURFACING (U.S. CLS. 26, 39 AND 44).
FIRST USE 7-28-2011; IN COMMERCE 7-28-2011.

4,119,387. STRYKER CORPORATION, KALAMAZOO, MI. SN 85-198,059. PUB. 4-26-2011, FILED 12-15-2010.

UNLEASH THE LIGHT

THE MARK CONSISTS OF STANDARD CHARACTERS WITHOUT CLAIM TO ANY PARTICULAR FONT, STYLE, SIZE, OR COLOR.
FOR MEDICAL/SURGICAL GOODS, NAMELY, MEDICAL BAGS DESIGNED TO HOLD PORTABLE ILLUMINATORS FOR USE BY MEDICAL/SURGICAL PERSONNEL FOR MEDICAL/SURGICAL PROCEDURES AND REPLACEMENT PARTS FOR THE AFORESAID ILLUMINATORS (U.S. CLS. 26, 39 AND 44).
FIRST USE 10-14-2011; IN COMMERCE 10-14-2011.

4,119,402. GAMMA MEDICA-IDEAS, INC., NORTHRIDGE, CA. SN 85-200,116. PUB. 4-26-2011, FILED 12-16-2010.

LUMAGEM

THE MARK CONSISTS OF STANDARD CHARACTERS WITHOUT CLAIM TO ANY PARTICULAR FONT, STYLE, SIZE, OR COLOR.
FOR BIOMEDICAL IMAGING SYSTEMS, NAMELY, APPARATUS AND INSTRUMENTS FOR MOLECULAR BREAST IMAGING (U.S. CLS. 26, 39 AND 44).
FIRST USE 1-0-2000; IN COMMERCE 1-0-2000.

CLASS 10—(Continued).

4,119,477. BECTON, DICKINSON AND COMPANY, FRANKLIN LAKES, NJ. SN 85-220,004. PUB. 6-7-2011, FILED 1-18-2011.

UniVia

THE MARK CONSISTS OF STANDARD CHARACTERS WITHOUT CLAIM TO ANY PARTICULAR FONT, STYLE, SIZE, OR COLOR.
THE WORDING "UNIVIA" HAS NO MEANING IN A FOREIGN LANGUAGE.
FOR CONNECTORS FOR SMALL BORE MEDICAL TUBING SETS (U.S. CLS. 26, 39 AND 44).
FIRST USE 11-30-2011; IN COMMERCE 11-30-2011.

4,119,488. RADIAL ASSIST, LLC, ROSWELL, GA. SN 85-221,746. PUB. 6-7-2011, FILED 1-20-2011.

RAD REST

THE MARK CONSISTS OF STANDARD CHARACTERS WITHOUT CLAIM TO ANY PARTICULAR FONT, STYLE, SIZE, OR COLOR.
NO CLAIM IS MADE TO THE EXCLUSIVE RIGHT TO USE "REST", APART FROM THE MARK AS SHOWN.
FOR ARM PAD FOR MEDICAL PROCEDURES (U.S. CLS. 26, 39 AND 44).
FIRST USE 9-28-2011; IN COMMERCE 9-28-2011.

4,119,619. RETRACTABLE TECHNOLOGIES, INC., LITTLE ELM, TX. SN 85-285,577. PUB. 10-4-2011, FILED 4-4-2011.



OWNER OF U.S. REG. NO. 3,732,661.

CLASS 10—(Continued).

THE MARK CONSISTS OF THE STYLIZED END OF A SYRINGE CONTAINED WITHIN A BOX.

FOR SYRINGES FOR MEDICAL USE, NAMELY, NEEDLELESS THERAPEUTIC SYRINGES HAVING A LUER CONNECTOR ATTACHABLE TO AN INTRAVENOUS FLUID DELIVERY SYSTEM AND A FORWARDLY EXTENDING AND OUTWARDLY INCLINED GUIDE STRUCTURE FACILITATING THE ATTACHMENT (U.S. CLS. 26, 39 AND 44).

FIRST USE 6-25-2010; IN COMMERCE 6-25-2010.

CLASS 11—(Continued).

4,118,895. STICHTING ENERGIEONDERZOEK CENTRUM NEDERLAND, PETTEN, NETHERLANDS. SN 77-655,956. PUB. 10-27-2009, FILED 1-24-2009.

4,119,671. KANDI KOATED ENTERTAINMENT, INC., ATLANTA, GA. SN 85-316,493. PUB. 9-13-2011, FILED 5-10-2011.

HAPPINESS & JOY

THE MARK CONSISTS OF STANDARD CHARACTERS WITHOUT CLAIM TO ANY PARTICULAR FONT, STYLE, SIZE, OR COLOR.

FOR ADULT SEXUAL STIMULATION AIDS, NAMELY, DEVICES FOR MASSAGING OR VIBRATING EXTERNAL AND INTERNAL PORTIONS OF THE BODY, VIBRATING AND NON-VIBRATING REPRODUCTIONS OF PARTS OF THE MALE AND FEMALE ANATOMIES, RINGS, CLAMPS, STIMULATORS, VIBRATORS, DILDOS, DONGS, BUTT PLUGS, RINGS TO BE WORN ABOUT THE PENIS, SLEEVES ON VIBRATORS SOLD TOGETHER WITH THE VIBRATORS (U.S. CLS. 26, 39 AND 44).

FIRST USE 8-16-2011; IN COMMERCE 8-16-2011.

THE MARK CONSISTS OF STANDARD CHARACTERS WITHOUT CLAIM TO ANY PARTICULAR FONT, STYLE, SIZE, OR COLOR.

FOR FILTRATION MATERIAL, NAMELY, CHEMICAL BASED FILTRATION MEMBRANES FOR THE FILTRATION OF WATER AND OR METHANOL (U.S. CLS. 13, 21, 23, 31 AND 34).

FIRST USE 10-10-2008; IN COMMERCE 11-14-2011.

4,119,679. ALLIANT SURGICAL PRODUCTS, LLC, RICHLAND, MI. SN 85-323,915. PUB. 11-8-2011, FILED 5-18-2011.

SURGE CARDIOVASCULAR

THE MARK CONSISTS OF STANDARD CHARACTERS WITHOUT CLAIM TO ANY PARTICULAR FONT, STYLE, SIZE, OR COLOR.

OWNER OF U.S. REG. NO. 3,415,797.

NO CLAIM IS MADE TO THE EXCLUSIVE RIGHT TO USE "CARDIOVASCULAR", APART FROM THE MARK AS SHOWN.

FOR MEDICAL DEVICES, NAMELY, HEART AND PERFUSION DISPOSABLE SURGICAL DEVICES, TUBE SETS CONSISTING OF PLASTIC TUBING AND FITTINGS FOR CONNECTING THE TUBING FOR BLOOD TRANSFER TO PATIENT, PATIENT TEMPERATURE MONITORING DEVICES, SUTURE GUIDES FOR USE DURING HEART VALVE SURGERY (U.S. CLS. 26, 39 AND 44).

FIRST USE 8-31-2011; IN COMMERCE 8-31-2011.

4,118,935. VALLS HOLDINGS, INC., MIAMI, FL. SN 77-805,107. PUB. 12-7-2010, FILED 8-14-2009.

ITALMAX

THE MARK CONSISTS OF STANDARD CHARACTERS WITHOUT CLAIM TO ANY PARTICULAR FONT, STYLE, SIZE, OR COLOR.

FOR ELECTRIC COFFEE MAKERS; ELECTRIC ESPRESSO MACHINES (U.S. CLS. 13, 21, 23, 31 AND 34).

FIRST USE 8-25-2009; IN COMMERCE 9-8-2009.

CLASS 11—ENVIRONMENTAL CONTROL APPARATUS

CLASS 11—(Continued).

4,119,076. SMARTRAY INC., MARKHAM, CANADA. SN 85-014,545. PUB. 10-5-2010, FILED 4-15-2010.

SMARTRAY

THE MARK CONSISTS OF STANDARD CHARACTERS WITHOUT CLAIM TO ANY PARTICULAR FONT, STYLE, SIZE, OR COLOR.

FOR CEILING LIGHTS; ELECTRIC HOLIDAY LIGHTS; ELECTRIC LIGHT BULBS; ELECTRIC LIGHTING FIXTURES; ELECTRIC LIGHTS FOR CHRISTMAS TREES; ELECTRIC NIGHT LIGHTS; ELECTRIC TRACK LIGHTING UNITS; FLUORESCENT ELECTRIC LIGHT BULBS; FLUORESCENT LIGHTING TUBES; LANDSCAPE LIGHTING INSTALLATIONS; LED (LIGHT EMITTING DIODE) LIGHTING FIXTURES; LED (LIGHT EMITTING DIODES) LIGHTING FIXTURES FOR USE IN DISPLAY, COMMERCIAL, INDUSTRIAL, RESIDENTIAL, AND ARCHITECTURAL ACCENT LIGHTING APPLICATIONS; LED LIGHT ASSEMBLIES FOR STREET LIGHTS, SIGNS, COMMERCIAL LIGHTING, AUTOMOBILES, BUILDINGS, AND OTHER ARCHITECTURAL USES; LED LIGHT BULBS; LED LIGHTING FIXTURES FOR INDOOR AND OUTDOOR LIGHTING APPLICATIONS; LIGHT BULBS; LIGHT POST LUMINAIRES; LIGHTED PARTY-THEMED DECORATIONS, ELECTRIC LIGHT DECORATIVE STRINGS; LIGHTING FIXTURES; LIGHTING FIXTURES THAT INTEGRATE NATURAL DAYLIGHT AND FLUORESCENT LIGHTING INTO THE FIXTURE; LIGHTING TRACKS; LIGHTING TUBES; LUMINAIRES, USING LIGHT EMITTING DIODES (LEDS) AS A LIGHT SOURCE, FOR STREET OR ROADWAY LIGHTING; OPTICAL LENS COVERS THAT IMPROVES LIGHT OUTPUT AND UNIFORMITY, AND PROTECTS THE LED SOLD AS A FEATURE OF AN LED LIGHTING SYSTEM; OUTDOOR LIGHTED CHRISTMAS ORNAMENTS; OUTDOOR LIGHTING, NAMELY, PAVER LIGHTS; READING LIGHTS; SOLAR LIGHT FIXTURES, NAMELY, INDOOR AND OUTDOOR SOLAR POWERED LIGHTING UNITS AND FIXTURES (U.S. CLS. 13, 21, 23, 31 AND 34).

FIRST USE 1-1-2010; IN COMMERCE 1-1-2010.

4,119,109. SAMSUNG ELECTRONICS CO., LTD., SUWON-SI, GYEONGGI-DO, REPUBLIC OF KOREA. SN 85-041,898. PUB. 11-2-2010, FILED 5-18-2010.



NO CLAIM IS MADE TO THE EXCLUSIVE RIGHT TO USE "ZONE", APART FROM THE MARK AS SHOWN.

CLASS 11—(Continued).

THE COLOR(S) BLUE IS/ARE CLAIMED AS A FEATURE OF THE MARK.

THE MARK CONSISTS OF THE WORDS "FLEX ZONE" WITH THE DEGREE SYMBOL AFTER "ZONE", AND BELOW THE WORDS IS A BLOCK DESIGN OF A BOTTLE AND WINE GLASS, A SLICE OF CHEESE, A CAN WITH AN ASTERISK, AND FISH AND BREAD IN GRADATIONS OF THE COLOR BLUE.

FOR REFRIGERATORS (U.S. CLS. 13, 21, 23, 31 AND 34).

FIRST USE 3-0-2010; IN COMMERCE 3-0-2010.

4,119,239. WHIRLPOOL PROPERTIES, INC., ST. JOSEPH, MI. SN 85-114,726. PUB. 2-1-2011, FILED 8-24-2010.



OWNER OF U.S. REG. NOS. 1,251,511, 2,958,503, AND OTHERS.

THE MARK CONSISTS OF THE WORD "WHIRLPOOL", AND A SWIRL AND RING DESIGN.

FOR PORTABLE ELECTRIC FANS (U.S. CLS. 13, 21, 23, 31 AND 34).

FIRST USE 4-10-2011; IN COMMERCE 4-10-2011.

4,119,270. COWEN, STEPHEN R., LONGMONT, CO. SN 85-136,238. PUB. 3-29-2011, FILED 9-23-2010.

WINGMAN

THE MARK CONSISTS OF STANDARD CHARACTERS WITHOUT CLAIM TO ANY PARTICULAR FONT, STYLE, SIZE, OR COLOR.

FOR TOILET SEAT (U.S. CLS. 13, 21, 23, 31 AND 34). FIRST USE 7-23-2010; IN COMMERCE 6-10-2011.

CLASS 11—(Continued).

4,119,403. TWIN STAR INTERNATIONAL, INC., DELRAY BEACH, FL. SN 85-200,170. PUB. 4-26-2011, FILED 12-17-2010.

ELECTRAHEAT

THE MARK CONSISTS OF STANDARD CHARACTERS WITHOUT CLAIM TO ANY PARTICULAR FONT, STYLE, SIZE, OR COLOR.

FOR ELECTRIC FIREPLACE INSERTS, COMPRISED OF ANDIRONS, ARTIFICIAL LOGS AND ARTIFICIAL EMBERS, PORTABLE ELECTRIC HEATERS AND ELECTRIC RADIANT HEATERS FOR HOUSEHOLD USE; ELECTRIC SPACE HEATERS, CERAMIC HEATERS, CERAMIC HEATERS, NAMELY, PORTABLE SPACE HEATERS WHICH RADIATE HEAT THROUGH CERAMIC PANELS (U.S. CLS. 13, 21, 23, 31 AND 34).
FIRST USE 11-1-2011; IN COMMERCE 11-1-2011.

4,119,404. TWIN STAR INTERNATIONAL, INC., DELRAY BEACH, FL. SN 85-200,171. PUB. 4-26-2011, FILED 12-17-2010.

SPECTRAFLAME

THE MARK CONSISTS OF STANDARD CHARACTERS WITHOUT CLAIM TO ANY PARTICULAR FONT, STYLE, SIZE, OR COLOR.

FOR ELECTRIC FIREPLACE INSERTS, COMPRISED OF ANDIRONS, ARTIFICIAL LOGS AND ARTIFICIAL EMBERS, PORTABLE ELECTRIC HEATERS AND ELECTRIC RADIANT HEATERS FOR HOUSEHOLD USE; ELECTRIC SPACE HEATERS, CERAMIC HEATERS, CERAMIC HEATERS, NAMELY, PORTABLE SPACE HEATERS WHICH RADIATE HEAT THROUGH CERAMIC PANELS (U.S. CLS. 13, 21, 23, 31 AND 34).
FIRST USE 11-1-2011; IN COMMERCE 11-1-2011.

4,119,455. SOUTHERN PRIDE DISTRIBUTING, LLC, MARION, IL. SN 85-213,204. PUB. 5-3-2011, FILED 1-7-2011.

ROLLTISSERIE

THE MARK CONSISTS OF STANDARD CHARACTERS WITHOUT CLAIM TO ANY PARTICULAR FONT, STYLE, SIZE, OR COLOR.

FOR BARBECUE OVENS AND SMOKERS (U.S. CLS. 13, 21, 23, 31 AND 34).
FIRST USE 10-21-2011; IN COMMERCE 10-21-2011.

CLASS 11—(Continued).

4,119,459. MEGATURBO GROUP INTERNATIONAL, LLC, DORAL, FL. SN 85-214,336. PUB. 6-21-2011, FILED 1-10-2011.

FURIA PROFESSIONAL

THE MARK CONSISTS OF STANDARD CHARACTERS WITHOUT CLAIM TO ANY PARTICULAR FONT, STYLE, SIZE, OR COLOR.

NO CLAIM IS MADE TO THE EXCLUSIVE RIGHT TO USE "PROFESSIONAL", APART FROM THE MARK AS SHOWN.

THE ENGLISH TRANSLATION OF "FURIA" IN THE MARK IS "RAGE".

FOR HAIR DRYERS (U.S. CLS. 13, 21, 23, 31 AND 34).
FIRST USE 12-5-2011; IN COMMERCE 1-17-2012.

4,119,605. HENERGY GROUP (NORTH AMERICA) INC., VANCOUVER BC V7X 1L3, CANADA. SN 85-274,026. PUB. 8-9-2011, FILED 3-22-2011.

SUN KING

THE MARK CONSISTS OF STANDARD CHARACTERS WITHOUT CLAIM TO ANY PARTICULAR FONT, STYLE, SIZE, OR COLOR.

FOR BAKING OVENS; BARBECUE GRILLS; ELECTRIC GRILLS; GAS BURNERS; GAS GRILLS; GAS STOVES; HOT PLATES; ROASTERS POWERED BY PROPANE GAS; SOLAR COLLECTORS; SOLAR ENERGY RECEIVERS (U.S. CLS. 13, 21, 23, 31 AND 34).
FIRST USE 4-23-2011; IN COMMERCE 4-23-2011.

4,119,668. KONCEPT TECHNOLOGIES, INC., MONROVIA, CA. SN 85-313,363. PUB. 9-27-2011, FILED 5-5-2011.

MOSSO

THE MARK CONSISTS OF STANDARD CHARACTERS WITHOUT CLAIM TO ANY PARTICULAR FONT, STYLE, SIZE, OR COLOR.

FOR LIGHTING LAMPS (U.S. CLS. 13, 21, 23, 31 AND 34).

FIRST USE 5-14-2011; IN COMMERCE 5-14-2011.

CLASS 12—VEHICLES

CLASS 12—(Continued).

4,118,804. FISKER AUTOMOTIVE, INC., ANAHEIM, CA. SN 77-346,448. PUB. 11-4-2008, FILED 12-7-2007.

Karma

THE MARK CONSISTS OF STANDARD CHARACTERS WITHOUT CLAIM TO ANY PARTICULAR FONT, STYLE, SIZE, OR COLOR.

FOR MOTOR VEHICLES, NAMELY, CARS AND STRUCTURAL PARTS FOR ALL OF THE AFORESAID GOODS; AUTOMOTIVE BODIES AND STRUCTURAL PARTS THEREFORE (U.S. CLS. 19, 21, 23, 31, 35 AND 44).
FIRST USE 10-13-2011; IN COMMERCE 10-13-2011.

4,118,863. BRIDGESTONE BRANDS, LLC, NASHVILLE, TN. SN 77-532,391. PUB. 11-4-2008, FILED 7-28-2008.

FUEL FIGHTER

THE MARK CONSISTS OF STANDARD CHARACTERS WITHOUT CLAIM TO ANY PARTICULAR FONT, STYLE, SIZE, OR COLOR.

FOR VEHICLE TIRES (U.S. CLS. 19, 21, 23, 31, 35 AND 44).
FIRST USE 4-1-2011; IN COMMERCE 4-1-2011.

4,118,885. NOVATORQUE, INC., SUNNYVALE, CA. SN 77-636,258. PUB. 3-31-2009, FILED 12-18-2008.

Novatorque

THE MARK CONSISTS OF STANDARD CHARACTERS WITHOUT CLAIM TO ANY PARTICULAR FONT, STYLE, SIZE, OR COLOR.

FOR ELECTRIC MOTORS FOR LAND VEHICLES (U.S. CLS. 19, 21, 23, 31, 35 AND 44).
FIRST USE 9-1-2005; IN COMMERCE 10-11-2011.

CLASS 12—(Continued).

4,119,163. SHANDONG HENGFENG RUBBER & PLASTIC CO., LTD., DONGYING SHANDONG, CHINA. SN 85-068,084. PUB. 11-2-2010, FILED 6-21-2010.

MIRAGE

THE MARK CONSISTS OF STANDARD CHARACTERS WITHOUT CLAIM TO ANY PARTICULAR FONT, STYLE, SIZE, OR COLOR.

FOR TIRES FOR USE ON PASSENGER VEHICLES, LIGHT TRUCK VEHICLES AND SPORTS UTILITY VEHICLES (U.S. CLS. 19, 21, 23, 31, 35 AND 44).

FIRST USE 12-20-2011; IN COMMERCE 12-20-2011.

4,119,263. NENE NEST, LLC, WINDERMERE, FL. SN 85-131,297. PUB. 5-24-2011, FILED 9-16-2010.

B.Y.O. BABY

THE MARK CONSISTS OF STANDARD CHARACTERS WITHOUT CLAIM TO ANY PARTICULAR FONT, STYLE, SIZE, OR COLOR.

NO CLAIM IS MADE TO THE EXCLUSIVE RIGHT TO USE "BABY", APART FROM THE MARK AS SHOWN.

FOR COVERS FOR CHILDREN'S CAR SEATS (U.S. CLS. 19, 21, 23, 31, 35 AND 44).

FIRST USE 11-0-2011; IN COMMERCE 11-0-2011.

4,119,434. NEXEN TIRE CORPORATION, KYONGSANG-NAM-DO, REPUBLIC OF KOREA. SN 85-207,736. PUB. 6-7-2011, FILED 12-30-2010.

N'fera

THE MARK CONSISTS OF STANDARD CHARACTERS WITHOUT CLAIM TO ANY PARTICULAR FONT, STYLE, SIZE, OR COLOR.

FOR INNER TUBES FOR VEHICLE TIRES, TIRES FOR LAND VEHICLES, SOLID TIRES FOR VEHICLE WHEELS, TIRE FLAPS FOR PROTECTION OF INNER TUBE WITHIN WHEEL RIM (U.S. CLS. 19, 21, 23, 31, 35 AND 44).

FIRST USE 1-3-2012; IN COMMERCE 1-3-2012.

CLASS 14—JEWELRY

CLASS 14—(Continued).

4,118,762. ROGACKI, ZENON A., NORTH HOLLYWOOD, CA. SN 76-704,050. PUB. 7-19-2011, FILED 8-9-2010.

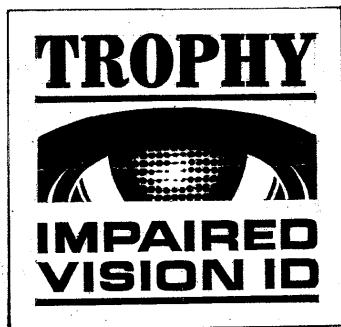

NO CLAIM IS MADE TO THE EXCLUSIVE RIGHT TO USE "IMPAIRED VISION ID", APART FROM THE MARK AS SHOWN.

THE MARK CONSISTS OF THE WORDING "TROPHY IMPAIRED VISION ID" WITH A STYLIZED REPRESENTATION OF AN EYE. THE TERMS "TROPHY" AND "VISION ID" ARE UNDERLINED AND THE MARK IS OUTLINED WITH A SQUARE BORDER.

FOR IDENTIFICATION BADGES OF PRECIOUS METAL FOR THE VISION IMPAIRED (U.S. CLS. 2, 27, 28 AND 50).

FIRST USE 10-30-2011; IN COMMERCE 10-30-2011.

4,118,793. RECORD WATCH CO. SA, 2610 SAINT-IMIER, SWITZERLAND. SN 77-299,412. PUB. 11-4-2008, FILED 10-9-2007.

RECORD

THE MARK CONSISTS OF STANDARD CHARACTERS WITHOUT CLAIM TO ANY PARTICULAR FONT, STYLE, SIZE, OR COLOR.

FOR WATCHES AND PARTS THEREOF; JEWELRY, HOROLOGICAL AND CHRONOMETRIC INSTRUMENTS, NAMELY, ALARM CLOCKS, CHRONOMETERS, CLOCKS, AND STOP WATCHES (U.S. CLS. 2, 27, 28 AND 50).

FIRST USE 11-17-2011; IN COMMERCE 12-15-2011.

CLASS 14—(Continued).

4,118,854. DIAMONDLITE INVESTMENTS LIMITED, HONG KONG SP ADMIN REG, CHINA. SN 77-501,694. PUB. 4-28-2009, FILED 6-18-2008.

CHETÉ

THE MARK CONSISTS OF STANDARD CHARACTERS WITHOUT CLAIM TO ANY PARTICULAR FONT, STYLE, SIZE, OR COLOR.

THE TERM "CHETÉ" HAS NO MEANING IN A FOREIGN LANGUAGE.

FOR BRACELETS, BROOCHES, EARRINGS, CLOCKS AND WATCHES, COSTUME JEWELRY, GEMSTONE JEWELRY AND IMITATION JEWELRY, NECKLACES, PRECIOUS AND SEMI-PRECIOUS STONES, AND RINGS (U.S. CLS. 2, 27, 28 AND 50).

FIRST USE 8-7-2007; IN COMMERCE 1-9-2012.

4,118,862. FLAT CREEK MOUNTAIN, INC., ASHEVILLE, NC. SN 77-519,845. PUB. 11-18-2008, FILED 7-11-2008.

LOVE, TRUE LOVE

THE MARK CONSISTS OF STANDARD CHARACTERS WITHOUT CLAIM TO ANY PARTICULAR FONT, STYLE, SIZE, OR COLOR.

FOR DRIED FLOWER JEWELRY ENCASED IN METAL AND PLASTIC; PENDANTS (U.S. CLS. 2, 27, 28 AND 50).

FIRST USE 3-15-2010; IN COMMERCE 3-15-2010.

4,118,969. PAYAL KEDIA, DBA ALLIA INC, NEW YORK, NY. SN 77-880,047. PUB. 1-11-2011, FILED 11-24-2009.

ALLIA

THE COLOR(S) BLACK IS/ARE CLAIMED AS A FEATURE OF THE MARK.

THE MARK CONSISTS OF THE WORDING "ALLIA" IN A STYLIZED FONT WITH A SCRIPT "A".

FOR JEWELRY (U.S. CLS. 2, 27, 28 AND 50).

FIRST USE 1-1-2010; IN COMMERCE 1-1-2010.

CLASS 14—(Continued).

4,119,062. TISSOT SA, 2400 LE LOCLE, SWITZERLAND. SN 85-001,038. PUB. 10-12-2010, FILED 3-29-2010.

TISSOT VISODATE

THE MARK CONSISTS OF STANDARD CHARACTERS WITHOUT CLAIM TO ANY PARTICULAR FONT, STYLE, SIZE, OR COLOR.

PRIORITY CLAIMED UNDER SEC. 44(D) ON SWITZERLAND APPLICATION NO. 61188/2009, FILED 10-9-2009, REG. NO. 592409, DATED 10-20-2009, EXPIRES 10-9-2019.

OWNER OF U.S. REG. NOS. 1,639,684, 3,213,659, AND OTHERS.

FOR HOROLOGICAL AND CHRONOMETRIC INSTRUMENTS (U.S. CLS. 2, 27, 28 AND 50).

FIRST USE 2-24-2010; IN COMMERCE 2-24-2010.

CLASS 14—(Continued).

4,119,335. ADVANCE WATCH COMPANY LTD., NEW YORK, NY. SN 85-182,260. PUB. 11-1-2011, FILED 11-22-2010.

NITRO

THE MARK CONSISTS OF STANDARD CHARACTERS WITHOUT CLAIM TO ANY PARTICULAR FONT, STYLE, SIZE, OR COLOR.

FOR WATCHES (U.S. CLS. 2, 27, 28 AND 50).

FIRST USE 10-5-2011; IN COMMERCE 10-5-2011.

4,119,165. TYLER MANNING, LOUISVILLE, KY. SN 85-069,709. PUB. 5-24-2011, FILED 6-23-2010.

AG2G

THE MARK CONSISTS OF STANDARD CHARACTERS WITHOUT CLAIM TO ANY PARTICULAR FONT, STYLE, SIZE, OR COLOR.

FOR JEWELRY, NAMELY, BRACELETS, RUBBER OR SILICON WRISTBANDS IN THE NATURE OF A BRACELET, ANKLETS, EARRINGS, NECKLACES AND RINGS (U.S. CLS. 2, 27, 28 AND 50).

FIRST USE 7-20-2010; IN COMMERCE 7-20-2010.

4,119,408. DESIGNS BY FMC, INC., BROOKLYN, NY. SN 85-201,745. PUB. 4-26-2011, FILED 12-20-2010.

STONIQUE CREATIONS

THE MARK CONSISTS OF STANDARD CHARACTERS WITHOUT CLAIM TO ANY PARTICULAR FONT, STYLE, SIZE, OR COLOR.

FOR JEWELRY (U.S. CLS. 2, 27, 28 AND 50).

FIRST USE 12-0-2010; IN COMMERCE 12-0-2010.

4,119,169. BROUN, WAYNE H., WARRIEWOOD BEACH NSW, AUSTRALIA. SN 85-073,101. PUB. 12-7-2010, FILED 6-28-2010.

BROUN OF COLSTOUN

THE MARK CONSISTS OF STANDARD CHARACTERS WITHOUT CLAIM TO ANY PARTICULAR FONT, STYLE, SIZE, OR COLOR.

FOR JEWELRY; IMITATION JEWELRY; COSTUME JEWELRY; JEWELRY OF NON-PRECIOUS STONES, METALS AND PEWTER; BROOCHES; MEDALLIONS; PINS BEING JEWELRY; NECKLACES; PENDANTS; LAPEL PINS; TIE FASTENERS AND PINS (U.S. CLS. 2, 27, 28 AND 50).

FIRST USE 12-1-2011; IN COMMERCE 12-1-2011.

4,119,422. PACIFIC SUNWEAR OF CALIFORNIA, INC., ANAHEIM, CA. SN 85-203,000. PUB. 5-10-2011, FILED 12-21-2010.

WITH LOVE FROM CALIFORNIA

THE MARK CONSISTS OF STANDARD CHARACTERS WITHOUT CLAIM TO ANY PARTICULAR FONT, STYLE, SIZE, OR COLOR.

NO CLAIM IS MADE TO THE EXCLUSIVE RIGHT TO USE "FROM CALIFORNIA", APART FROM THE MARK AS SHOWN.

FOR JEWELRY, NAMELY, BRACELETS, EARRINGS, NECKLACES AND RINGS (U.S. CLS. 2, 27, 28 AND 50).

FIRST USE 3-1-2011; IN COMMERCE 3-1-2011.

CLASS 14—(Continued).

4,119,520. BIJOUX TERNER, LLC, MIAMI, FL. SN 85-230,955.
PUB. 5-31-2011, FILED 2-1-2011.

TRESOR DU TEMP

THE MARK CONSISTS OF STANDARD CHARACTERS WITHOUT CLAIM TO ANY PARTICULAR FONT, STYLE, SIZE, OR COLOR.

THE ENGLISH TRANSLATION OF "TRESOR DU TEMP" IN THE MARK IS "TREASURE OF TIME".

FOR JEWELRY, WATCHES (U.S. CLS. 2, 27, 28 AND 50).

FIRST USE 6-15-2011; IN COMMERCE 6-15-2011.

4,119,539. WALDRON, MARCIE BECKER, SONOMA, CA. SN 85-238,340. PUB. 6-14-2011, FILED 2-9-2011.



THE MARK CONSISTS OF A FIVE POINT STAR WITH A SWIRL IN THE CENTER OF THE STAR; THE WORDS "LIFE STARS" UNDERNEATH THE STAR; THE "T" IN THE WORD "STARS" IN THE SHAPE OF A HUMAN STICK FIGURE.

FOR EARRINGS, NECKLACES AND LAPEL PINS (U.S. CLS. 2, 27, 28 AND 50).

FIRST USE 1-31-2011; IN COMMERCE 1-31-2011.

4,119,544. SCHUBACH ENTERPRISES, INC., SCOTTSDALE, AZ. SN 85-241,179. PUB. 11-1-2011, FILED 2-14-2011.



OWNER OF U.S. REG. NO. 2,499,090.

CLASS 14—(Continued).

THE MARK CONSISTS OF A FINGER RING WITH A SHINING STONE STUDDED IN IT WITH 7 TRIANGLES ABOVE THE STONE IN THE RING.

FOR PRECIOUS METALS AND THEIR ALLOYS; GOODS MADE WITH PRECIOUS METALS OR COATED THERE WITH, NAMELY, BRACELETS, BROACHES, BROOCHES, IDENTIFICATION BRACELETS, JEWELRY CHAINS, JEWELRY CHARMS, ANKLETS, CROSSES, PENDANTS, RINGS, JEWELRY FOR PETS, CROSSES, HOROLOGICAL AND CHRONOMETRIC INSTRUMENTS AND PARTS THEREOF; WATCHES (U.S. CLS. 2, 27, 28 AND 50).

FIRST USE 2-26-2000; IN COMMERCE 2-26-2000.

4,119,560. BIJOUX TERNER, LLC, MIAMI, FL. SN 85-250,447.
PUB. 5-31-2011, FILED 2-24-2011.



THE COLOR(S) PINE GREEN IS/ARE CLAIMED AS A FEATURE OF THE MARK.

THE MARK CONSISTS OF THE STYLIZED WORD "TRESOR" IN PINE GREEN, ABOVE AND TO THE LEFT OF THE WORDS "DU TEMP" IN PINE GREEN. THE WORD "DU" IS IN SMALLER FONT SIZE AND ALL LOWER CASE LETTERS. "TEMP" IN THE SAME SIZE FONT AS TRESOR. ON THE LOWER LEFT OF THE WORD "TEMP" IS A PINE GREEN CIRCLE AROUND "TE", FORMING A HIGHLY STYLIZED CLOCK FACE WITH THE "T" AS A CLOCK HAND IN THE 12 POSITION.

THE ENGLISH TRANSLATION OF "TRESOR DU TEMP" IN THE MARK IS "TREASURE OF TIME".

FOR JEWELRY, WATCHES (U.S. CLS. 2, 27, 28 AND 50).

FIRST USE 6-15-2011; IN COMMERCE 6-15-2011.

4,119,630. REBECCA MICHELLE DOWNIN, DAVENPORT, FL. SN 85-292,274. PUB. 8-23-2011, FILED 4-11-2011.



THE MARK CONSISTS OF THE WORD SCULPTURINGS IN STYLIZED FONT.

FOR JEWELRY, NAMELY, RINGS (U.S. CLS. 2, 27, 28 AND 50).

FIRST USE 5-16-2009; IN COMMERCE 12-9-2009.

CLASS 14—(Continued).

4,119,636. STANLEY CREATIONS, INC., MELROSE PARK, PA. SN 85-295,050. PUB. 9-13-2011, FILED 4-14-2011.

STERLING 'N' ICE

THE MARK CONSISTS OF STANDARD CHARACTERS WITHOUT CLAIM TO ANY PARTICULAR FONT, STYLE, SIZE, OR COLOR.

NO CLAIM IS MADE TO THE EXCLUSIVE RIGHT TO USE "STERLING", APART FROM THE MARK AS SHOWN. FOR CRYSTAL JEWELRY SET IN STERLING SILVER (U.S. CLS. 2, 27, 28 AND 50).

FIRST USE 10-31-2011; IN COMMERCE 10-31-2011.

CLASS 15—(Continued).

4,118,834. LOBAN, JOSEPH PETER, EVANSTON, IL. SN 77-468,197. PUB. 10-14-2008, FILED 5-7-2008.

JAM N' STAND

THE MARK CONSISTS OF STANDARD CHARACTERS WITHOUT CLAIM TO ANY PARTICULAR FONT, STYLE, SIZE, OR COLOR.

NO CLAIM IS MADE TO THE EXCLUSIVE RIGHT TO USE "STAND", APART FROM THE MARK AS SHOWN. FOR MUSICAL INSTRUMENT ACCESSORIES, NAMELY, STANDS AND CARRYING BAGS (U.S. CLS. 2, 21 AND 36).

FIRST USE 12-29-2011; IN COMMERCE 12-29-2011.

4,119,694. DILLARD'S, LITTLE ROCK, AR. SN 85-335,344. PUB. 11-1-2011, FILED 6-1-2011.

Mr. Bingle

THE MARK CONSISTS OF STANDARD CHARACTERS WITHOUT CLAIM TO ANY PARTICULAR FONT, STYLE, SIZE, OR COLOR.

FOR BRACELETS; CHARMS FOR COLLAR JEWELRY AND BRACELET; EARRINGS; NECKLACES (U.S. CLS. 2, 27, 28 AND 50).

FIRST USE 11-15-2011; IN COMMERCE 11-15-2011.

4,119,693. GREEN, PAUL M., ST. AUGUSTINE, FL. SN 85-333,752. PUB. 10-25-2011, FILED 5-31-2011.

STAR STRAP

THE MARK CONSISTS OF STANDARD CHARACTERS WITHOUT CLAIM TO ANY PARTICULAR FONT, STYLE, SIZE, OR COLOR.

NO CLAIM IS MADE TO THE EXCLUSIVE RIGHT TO USE "STRAP", APART FROM THE MARK AS SHOWN.

FOR GUITAR STRAPS (U.S. CLS. 2, 21 AND 36).

FIRST USE 10-31-2011; IN COMMERCE 11-8-2011.

4,119,715. M. Z. BERGER & CO., INC., LONG ISLAND CITY, NY. SN 85-357,263. PUB. 10-11-2011, FILED 6-27-2011.

GALAXY

THE MARK CONSISTS OF STANDARD CHARACTERS WITHOUT CLAIM TO ANY PARTICULAR FONT, STYLE, SIZE, OR COLOR.

OWNER OF U.S. REG. NO. 1,138,323. FOR WATCHES (U.S. CLS. 2, 27, 28 AND 50). FIRST USE 8-20-2011; IN COMMERCE 8-20-2011.

CLASS 16—PAPER GOODS AND PRINTED MATTER

4,118,766. CHASE MEDICAL COMMUNICATIONS, INC., WILTON, CT. SN 76-704,652. PUB. 5-31-2011, FILED 9-27-2010.

RESEARCH & REVIEW IN DIABETES

THE MARK CONSISTS OF STANDARD CHARACTERS WITHOUT CLAIM TO ANY PARTICULAR FONT, STYLE, SIZE, OR COLOR.

OWNER OF U.S. REG. NOS. 3,214,567, 3,578,358, AND OTHERS.

NO CLAIM IS MADE TO THE EXCLUSIVE RIGHT TO USE "DIABETES", APART FROM THE MARK AS SHOWN. SEC. 2(F) AS TO "RESEARCH" AND "REVIEW".

FOR PRINTED PUBLICATIONS, NAMELY, MAGAZINES, NEWSLETTERS AND MEDICAL JOURNALS FEATURING INFORMATION ABOUT DIABETES AND MEDICAL INFORMATION RELATED THERETO (U.S. CLS. 2, 5, 22, 23, 29, 37, 38 AND 50).

FIRST USE 1-17-2012; IN COMMERCE 1-17-2012.

CLASS 15—MUSICAL INSTRUMENTS

CLASS 16—(Continued).

4,118,777. VALIANT ENTERTAINMENT, INC., ROAD TOWN, BR. VIRGIN ISLANDS. SN 77-069,293. PUB. 5-31-2011, FILED 12-21-2006.

RAI AND THE FUTURE FORCE

THE MARK CONSISTS OF STANDARD CHARACTERS WITHOUT CLAIM TO ANY PARTICULAR FONT, STYLE, SIZE, OR COLOR.

OWNER OF U.S. REG. NO. 3,743,355.

FOR PRINTED MATTER AND PAPER GOODS, NAMELY, BOOKS FEATURING COMIC BOOK CHARACTERS AND STORIES IN ILLUSTRATED FORM; COMIC BOOKS, GRAPHIC NOVELS, COMIC STRIPS, AND MAGAZINES FEATURING COMIC BOOK CHARACTERS, AND STORIES IN PRINTED FORM FEATURING COMIC BOOK CHARACTERS; POSTERS; ART PRINTS; TRADING CARDS; PRINTED COLLECTOR'S CARDS (U.S. CLS. 2, 5, 22, 23, 29, 37, 38 AND 50).

FIRST USE 5-0-1993; IN COMMERCE 5-0-1993.

4,118,819. GAMES WORKSHOP LIMITED, NOTTINGHAM, UNITED KINGDOM. SN 77-426,903. PUB. 9-29-2009, FILED 3-20-2008.

NECRONS

THE MARK CONSISTS OF STANDARD CHARACTERS WITHOUT CLAIM TO ANY PARTICULAR FONT, STYLE, SIZE, OR COLOR.

OWNER OF U.S. REG. NOS. 2,206,015 AND 2,723,575.

FOR FANTASY, SCIENCE FICTION, HOBBY, WAR, SKIRMISH, AND ROLE PLAYING GAME EQUIPMENT IN THE NATURE OF GAME BOOK MANUALS (U.S. CLS. 2, 5, 22, 23, 29, 37, 38 AND 50).

FIRST USE 7-0-2002; IN COMMERCE 7-0-2002.

4,118,872. MARVEL CHARACTERS, INC., MANHATTAN BEACH, CA. SN 77-566,689. PUB. 1-27-2009, FILED 9-10-2008.

FALCON

THE MARK CONSISTS OF STANDARD CHARACTERS WITHOUT CLAIM TO ANY PARTICULAR FONT, STYLE, SIZE, OR COLOR.

FOR COMIC BOOKS; PRINTED PERIODICALS IN THE FIELD OF COMIC BOOK STORIES AND ARTWORK (U.S. CLS. 2, 5, 22, 23, 29, 37, 38 AND 50).

FIRST USE 3-2-2011; IN COMMERCE 3-2-2011.

CLASS 16—(Continued).

4,118,877. UNIVERSITY OF CHICAGO, THE, CHICAGO, IL. SN 77-609,372. PUB. 9-29-2009, FILED 11-6-2008.



The University of Chicago Booth School of Business

OWNER OF U.S. REG. NOS. 1,876,527 AND 2,668,437.

NO CLAIM IS MADE TO THE EXCLUSIVE RIGHT TO USE "CHICAGO" AND "SCHOOL OF BUSINESS", APART FROM THE MARK AS SHOWN.

THE MARK CONSISTS OF THE WORDS "CHICAGO BOOTH" TOGETHER WITH A DESIGN AND THE WORDS "THE UNIVERSITY OF CHICAGO BOOTH SCHOOL OF BUSINESS".

SEC. 2(F) AS TO "UNIVERSITY OF CHICAGO".

FOR STATIONERY; PAPER GOODS AND PRINTED MATTER, NAMELY, CALENDARS AND DECALS; PUBLICATIONS, NAMELY, JOURNALS, CATALOGUES, BOOKS AND MAGAZINES RELATING TO BUSINESS AND MANAGEMENT (U.S. CLS. 2, 5, 22, 23, 29, 37, 38 AND 50).

FIRST USE 1-0-2009; IN COMMERCE 1-0-2009.

4,118,940. IMBIBE MEDIA, INC., PORTLAND, OR. SN 77-819,653. PUB. 5-25-2010, FILED 9-3-2009.

IMBIBE

THE MARK CONSISTS OF STANDARD CHARACTERS WITHOUT CLAIM TO ANY PARTICULAR FONT, STYLE, SIZE, OR COLOR.

OWNER OF U.S. REG. NO. 3,142,891.

FOR BOOKS IN THE FIELD OF WINE, SPIRITS, COCKTAILS, BEER, COFFEE, TEA, SODA, AND JUICE (U.S. CLS. 2, 5, 22, 23, 29, 37, 38 AND 50).

FIRST USE 9-14-2011; IN COMMERCE 9-14-2011.

CLASS 16—(Continued).

4,118,983. YOGA PURA, LLC, PHOENIX, AZ. SN 77-896,849.
PUB. 6-15-2010, FILED 12-18-2009.

BOOTSTRAP

THE MARK CONSISTS OF STANDARD CHARACTERS WITHOUT CLAIM TO ANY PARTICULAR FONT, STYLE, SIZE, OR COLOR.

FOR INSTRUCTIONAL KITS FOR A SELF-MANAGED STRESS-RELIEF PROGRAM COMPRISING PRIMARILY OF A PRINTED LESSON BOOK AND ALSO CONTAINING CDS OF PRE-RECORDED INSTRUCTIONS, AND DVDS OF PRE-RECORDED INSTRUCTIONS, WITH THE AFOREMENTIONED BEING PACKAGED TOGETHER AND SOLD AS A UNIT; PRINTED INSTRUCTIONAL, EDUCATIONAL, AND TEACHING MATERIALS IN THE FIELD OF STRESS-RELIEF (U.S. CLS. 2, 5, 22, 23, 29, 37, 38 AND 50).

FIRST USE 1-13-2012; IN COMMERCE 1-13-2012.

4,118,986. RANDALL-REILLY PUBLISHING COMPANY, LLC, TUSCALOOSA, AL. SN 77-899,256. PUB. 10-5-2010, FILED 12-22-2009.

PROPICKUP

THE MARK CONSISTS OF STANDARD CHARACTERS WITHOUT CLAIM TO ANY PARTICULAR FONT, STYLE, SIZE, OR COLOR.

FOR PUBLICATIONS, NAMELY, MAGAZINES IN THE FIELD OF TRUCKING, CONSTRUCTION, AND LANDSCAPING; PUBLICATIONS, NAMELY, MAGAZINES FEATURING ARTICLES IN THE FIELD OF TRUCKING, CONSTRUCTION AND LANDSCAPING FOR BUSINESSES THAT USE TRUCKS FOR COMMERCIAL PURPOSES (U.S. CLS. 2, 5, 22, 23, 29, 37, 38 AND 50).

FIRST USE 5-31-2010; IN COMMERCE 5-31-2010.

4,118,988. AIR CONDITIONING CONTRACTORS OF AMERICA, ARLINGTON, VA. SN 77-899,283. PUB. 11-9-2010, FILED 12-22-2009.

MANUAL B

THE MARK CONSISTS OF STANDARD CHARACTERS WITHOUT CLAIM TO ANY PARTICULAR FONT, STYLE, SIZE, OR COLOR.

OWNER OF U.S. REG. NOS. 2,662,195, 2,721,051, AND OTHERS.

CLASS 16—(Continued).

NO CLAIM IS MADE TO THE EXCLUSIVE RIGHT TO USE "MANUAL", APART FROM THE MARK AS SHOWN.

FOR BOOKS AND PUBLICATIONS, NAMELY, MANUALS AND GUIDES IN THE FIELD OF TESTING AND BALANCING AIR AND WATER FLOW IN RESIDENTIAL AND COMMERCIAL HVAC APPLICATIONS (U.S. CLS. 2, 5, 22, 23, 29, 37, 38 AND 50).

FIRST USE 0-0-1970; IN COMMERCE 0-0-1970.

4,119,018. STERLING PUBLISHING CO., INC., NEW YORK, NY. SN 77-927,978. PUB. 12-28-2010, FILED 2-4-2010.

HOMEMADE LIVING

THE MARK CONSISTS OF STANDARD CHARACTERS WITHOUT CLAIM TO ANY PARTICULAR FONT, STYLE, SIZE, OR COLOR.

NO CLAIM IS MADE TO THE EXCLUSIVE RIGHT TO USE "HOMEMADE", APART FROM THE MARK AS SHOWN.

FOR PUBLICATIONS, NAMELY, A SERIES OF BOOKS ON VARIOUS HOME HOW-TO AND INSTRUCTIONAL TOPICS, NAMELY, RAISING CHICKENS, KEEPING BEES, KEEPING DAIRY ANIMALS, CANNING AND PRESERVING FRUITS, GROWING VEGETABLES, RECIPE BOOKS, AND GROWING AND PREPARING SEASONAL FOODS (U.S. CLS. 2, 5, 22, 23, 29, 37, 38 AND 50).

FIRST USE 3-1-2011; IN COMMERCE 3-1-2011.

4,119,019. STERLING PUBLISHING CO., INC., NEW YORK, NY. SN 77-927,983. PUB. 12-28-2010, FILED 2-4-2010.



NO CLAIM IS MADE TO THE EXCLUSIVE RIGHT TO USE "HOMEMADE", APART FROM THE MARK AS SHOWN.

THE MARK CONSISTS OF THE WORD "HOMEMADE" ABOVE THE WORD "LIVING" WITH THE LETTER "A" FORMING A HOUSE DESIGN, ALL WITHIN A SPEECH CLOUD WITH A HORIZONTAL TOP EDGE.

FOR PUBLICATIONS, NAMELY, A SERIES OF BOOKS ON VARIOUS HOME HOW-TO AND INSTRUCTIONAL TOPICS, NAMELY, RAISING CHICKENS, KEEPING BEES, KEEPING DAIRY ANIMALS, CANNING AND PRESERVING FRUITS, GROWING VEGETABLES, RECIPE BOOKS, AND GROWING AND PREPARING SEASONAL FOOD (U.S. CLS. 2, 5, 22, 23, 29, 37, 38 AND 50).

FIRST USE 3-1-2011; IN COMMERCE 3-1-2011.

CLASS 16—(Continued).

4,119,052. ANNABEL LANGBEIN, REMUERA, AUCKLAND, NEW ZEALAND. SN 77-982,906. PUB. 11-3-2009, FILED 10-10-2008.



THE NAME(S), PORTRAIT(S), AND/OR SIGNATURE(S) SHOWN IN THE MARK IDENTIFIES "ANNABEL LANGBEIN", WHOSE CONSENT(S) TO REGISTER IS MADE OF RECORD.

THE MARK CONSISTS OF THE STYLIZED LETTERS "AL" WITHIN A SHADED CIRCLE, WITH THE WORDS "ANNABEL LANGBEIN" IN LOWER CASE LETTERS, NEXT TO IT.

FOR PUBLICATIONS AND PRINTED MATTER, NAMELY, BOOKS ON THE SUBJECTS OF FOOD, COOKING, LIFESTYLES, GARDENING AND SUSTAINABLE LIVING, RECIPE BOOKS AND COOK BOOKS (U.S. CLS. 2, 5, 22, 23, 29, 37, 38 AND 50).

FIRST USE 0-0-2003; IN COMMERCE 0-0-2003.

4,119,117. STANLEY, JOHN D., BEDIAS, TX. SN 85-046,129. PUB. 10-26-2010, FILED 5-24-2010.

NATURE'S EDGE

THE MARK CONSISTS OF STANDARD CHARACTERS WITHOUT CLAIM TO ANY PARTICULAR FONT, STYLE, SIZE, OR COLOR.

FOR PRINTED CAMOUFLAGE PATTERNS TO BE APPLIED TO HARD SURFACES (U.S. CLS. 2, 5, 22, 23, 29, 37, 38 AND 50).

FIRST USE 11-1-2011; IN COMMERCE 11-1-2011.

4,119,301. CHRISTOPHER WRAY, CARLSBAD, CA. SN 85-156,977. PUB. 8-9-2011, FILED 10-20-2010.

THE WORTHY AWARD FOR THE UNWORTHY

THE MARK CONSISTS OF STANDARD CHARACTERS WITHOUT CLAIM TO ANY PARTICULAR FONT, STYLE, SIZE, OR COLOR.

NO CLAIM IS MADE TO THE EXCLUSIVE RIGHT TO USE "AWARD", APART FROM THE MARK AS SHOWN.

FOR PRINTED CERTIFICATES (U.S. CLS. 2, 5, 22, 23, 29, 37, 38 AND 50).

FIRST USE 1-15-2012; IN COMMERCE 1-15-2012.

CLASS 16—(Continued).

4,119,362. LICENSE BRANDING, LLC, SAN ANTONIO, TX. SN 85-190,501. PUB. 4-19-2011, FILED 12-3-2010.

FLIP AND GROW RICH

THE MARK CONSISTS OF STANDARD CHARACTERS WITHOUT CLAIM TO ANY PARTICULAR FONT, STYLE, SIZE, OR COLOR.

FOR EDUCATIONAL KITS SOLD AS A UNIT IN THE FIELD OF REAL ESTATE TRANSACTIONS CONSISTING PRIMARILY OF PRINTED INSTRUCTIONAL MATERIALS AND ALSO INCLUDING AUDIO CDS (U.S. CLS. 2, 5, 22, 23, 29, 37, 38 AND 50).

FIRST USE 11-0-2009; IN COMMERCE 11-0-2009.

4,119,446. FORTUGNO, JAMES, NEW CITY, NY. SN 85-210,705. PUB. 6-14-2011, FILED 1-5-2011.



NO CLAIM IS MADE TO THE EXCLUSIVE RIGHT TO USE "STICKERS", APART FROM THE MARK AS SHOWN. THE LIKENESS (OR, "PORTRAIT") IN THE MARK DOES NOT IDENTIFY A LIVING INDIVIDUAL.

THE MARK CONSISTS OF THE STYLIZED WORDING "FUNNY MONEY STICKERS" RUNNING ACROSS AN ADVERTISING BANNER AND A DESIGN COMPRISED OF A PERSON WEARING SUNGLASSES INSIDE AN OVAL WITH THE STYLIZED WORDS "E PLURABUS MOOLA!" AT THE TOP OF THE OVAL.

FOR ADHESIVE STICKERS THAT TEMPORARILY ADHERE TO PAPER CURRENCY, PHOTOGRAPHS OR DRAWINGS (U.S. CLS. 2, 5, 22, 23, 29, 37, 38 AND 50).

FIRST USE 3-1-2011; IN COMMERCE 3-1-2011.

CLASS 16—(Continued).

4,119,448. BAILEY, CAREY CLEMONS, PHOENIX, AZ. SN 85-211,299. PUB. 5-17-2011, FILED 1-5-2011.



THE MARK CONSISTS OF A CUPCAKE WITH A FLORAL LINER, AND ICING. THERE IS A POLK-A-DOTTED CHERRY ON TOP OF THE ICING, WITH A STEM AND LEAF COMING FROM CHERRY. UNDERNEATH THERE IS THE STYLIZED TEXT "CRAVINGS DESIRING GOD IN THE MIDST OF MOTHERHOOD".

FOR MOTIVATIONAL CARDS (U.S. CLS. 2, 5, 22, 23, 29, 37, 38 AND 50).

FIRST USE 4-15-2011; IN COMMERCE 12-8-2011.

4,119,458. DPE LABEL HOLDING CORP., BROOKLYN, NY. SN 85-214,301. PUB. 5-3-2011, FILED 1-10-2011.

El Capo

THE MARK CONSISTS OF STANDARD CHARACTERS WITHOUT CLAIM TO ANY PARTICULAR FONT, STYLE, SIZE, OR COLOR.

THE ENGLISH TRANSLATION OF "EL CAPO" IN THE MARK IS "THE BOSS".

FOR PRE-PAID TELEPHONE CALLING CARDS, NOT MAGNETICALLY ENCODED (U.S. CLS. 2, 5, 22, 23, 29, 37, 38 AND 50).

FIRST USE 11-27-2011; IN COMMERCE 11-27-2011.

CLASS 16—(Continued).

4,119,487. C&L CREATIVE BOOKS LLC, BRUNSWICK, OH. SN 85-221,719. PUB. 5-31-2011, FILED 1-20-2011.

LITTLE BOOKS FOR THE BIG IMAGINATION

THE MARK CONSISTS OF STANDARD CHARACTERS WITHOUT CLAIM TO ANY PARTICULAR FONT, STYLE, SIZE, OR COLOR.

FOR CHILDREN BOOKS (U.S. CLS. 2, 5, 22, 23, 29, 37, 38 AND 50).

FIRST USE 7-10-2011; IN COMMERCE 7-10-2011.

4,119,511. HAGGERTY, TERESA ANNE, PENSACOLA BEACH, FL. SN 85-228,577. PUB. 6-21-2011, FILED 1-28-2011.

DOORKNOB

THE MARK CONSISTS OF STANDARD CHARACTERS WITHOUT CLAIM TO ANY PARTICULAR FONT, STYLE, SIZE, OR COLOR.

FOR INSTRUCTIONAL, EDUCATIONAL, CAREER GUIDANCE AND LIFE COACHING MATERIALS FOR YOUTH AND ADULTS, NAMELY, BOOKS AND WORK BOOKS IN THE FIELD OF LIFE COACHING (U.S. CLS. 2, 5, 22, 23, 29, 37, 38 AND 50).

FIRST USE 5-1-2011; IN COMMERCE 5-1-2011.

4,119,612. PLYMOUTH TRADING COMPANY, LLC, PLYMOUTH, MN. SN 85-279,015. PUB. 8-30-2011, FILED 3-28-2011.

PLYMOUTH PRO

THE MARK CONSISTS OF STANDARD CHARACTERS WITHOUT CLAIM TO ANY PARTICULAR FONT, STYLE, SIZE, OR COLOR.

OWNER OF U.S. REG. NOS. 2,811,886 AND 3,942,247.

NO CLAIM IS MADE TO THE EXCLUSIVE RIGHT TO USE "PRO", APART FROM THE MARK AS SHOWN.

FOR PAINT APPLICATORS; PAINT BRUSHES; PAINT ROLLER COVERS; PAINT ROLLER HANDLES (U.S. CLS. 2, 5, 22, 23, 29, 37, 38 AND 50).

FIRST USE 8-8-2011; IN COMMERCE 8-8-2011.

CLASS 16—(Continued).

4,119,621. FAIRWEATHER, ANDREA B., BROOKLYN, NY. SN 85-286,522. PUB. 10-25-2011, FILED 4-5-2011.



NO CLAIM IS MADE TO THE EXCLUSIVE RIGHT TO USE "FACES", "SKIN", "CONCEALOR/FOUNDATION", "FACE", "POWDER", "BLUSH BRONZER", "EYES", "BASE COLOR", "LINER" AND "FACE CHART", APART FROM THE MARK AS SHOWN.

THE COLOR(S) WHITE, RED, YELLOW, GREEN, BLUE, BLACK, BROWN, LIGHT BROWN, LIGHT GRAY, AND DARK GRAY IS/ARE CLAIMED AS A FEATURE OF THE MARK.

THE MARK CONSISTS OF A FACE CHART WITH A RECTANGULAR BLACK BACKGROUND WITH LIGHT GRAY WORDING "FAIRWEATHER FACES FACE CHART", "(718)398-6938", AND "WWW.FAIRWEATHERFACES.COM"; BLACK WORDING "SKIN: CONCEALOR/FOUNDATION", "FACE: POWDER (ALL OVER) BLUSH BRONZER", "EYES: BASE COLOR", AND "DEFINE LINER"; A UNIVERSAL FEMALE WHITE FACE AGAINST A LIGHT GRAY BACKGROUND OUTLINED IN LIGHT AND DARK GRAY WITH BLACK AND WHITE EYES, EYE PUPILS IN BLACK, WHITE, AND SHADES OF BROWN, BLACK EYELASHES, BLACK EYELINER, EYESHADOW ON THE RIGHT EYE IN SHADES OF BROWN, LIGHT GRAY AND DARK GRAY BLUSH ON THE RIGHT CHEEK, LIGHT BROWN LIPSTICK ON THE RIGHT SIDE OF THE LIPS, 2 YELLOW CIRCLES, 2 RED CIRCLES, 2 BLUE CIRCLES, AND 1 GREEN CIRCLE ON THE LEFT SIDE OF FACE; A DARK GRAY RECTANGLE ON THE RIGHT OF THE FACE WITH A RED CIRCLE UNDER THE WORDING "SKIN:"; A YELLOW CIRCLE UNDER THE WORDING "FACE:"; A GREEN CIRCLE UNDER THE WORDING "EYES:"; AND A BLUE CIRCLE OVER THE WORDING "DEFINE LINER"; AND A WHITE RECTANGLE OUTLINED IN DARK GRAY WITH A BLACK AND WHITE EYE OUTLINED IN LIGHT AND DARK GRAY WITH AN EYE PUPIL IN BLACK, WHITE, AND SHADES OF BROWN, BLACK EYELASHES, BLACK EYELINER, FOUR GREEN CIRCLES AND FIVE BLUE CIRCLES.

FOR MAKEUP LESSON CHARTS USED TO PROVIDE INFORMATION IN THE FIELD OF BEAUTY IN THE NATURE OF A TOOL USED IN THE SELECTION AND USE OF COSMETICS, NAMELY, TO GUIDE THE USAGE OF MAKEUP BRUSHES, CONCEALER BRUSHES, FOUNDATION BRUSHES, POWDER BRUSHES, BLUSH BRUSHES, LIP BRUSHES, EYESHADOW BRUSHES (U.S. CLS. 2, 5, 22, 23, 29, 37, 38 AND 50).

FIRST USE 7-11-2008; IN COMMERCE 7-11-2008.

CLASS 16—(Continued).

4,119,670. BAYSHORE HISTORY, LLC, MARGATE, NJ. SN 85-314,275. PUB. 10-25-2011, FILED 5-6-2011.

THE CIVIL WAR MONITOR

THE MARK CONSISTS OF STANDARD CHARACTERS WITHOUT CLAIM TO ANY PARTICULAR FONT, STYLE, SIZE, OR COLOR.

NO CLAIM IS MADE TO THE EXCLUSIVE RIGHT TO USE "CIVIL WAR", APART FROM THE MARK AS SHOWN. FOR GENERAL FEATURE MAGAZINE IN THE FIELD OF CIVIL WAR HISTORY (U.S. CLS. 2, 5, 22, 23, 29, 37, 38 AND 50).

FIRST USE 9-21-2011; IN COMMERCE 9-21-2011.

4,119,730. ANDREWS MCMEEL PUBLISHING, LLC, KANSAS CITY, MO. SN 85-976,259. PUB. 5-10-2011, FILED 12-14-2010.

Petite Pocket Posh

THE MARK CONSISTS OF STANDARD CHARACTERS WITHOUT CLAIM TO ANY PARTICULAR FONT, STYLE, SIZE, OR COLOR.

OWNER OF U.S. REG. NO. 3,602,081.

NO CLAIM IS MADE TO THE EXCLUSIVE RIGHT TO USE "POCKET", APART FROM THE MARK AS SHOWN. FOR PUZZLE BOOKS (U.S. CLS. 2, 5, 22, 23, 29, 37, 38 AND 50).

FIRST USE 10-25-2011; IN COMMERCE 10-25-2011.

CLASS 16—(Continued).

4,119,734. SUMMIT ENTERTAINMENT, LLC, SANTA MONICA, CA. SN 85-976,264. PUB. 5-24-2011, FILED 4-6-2010.



THE MARK CONSISTS OF A CIRCULAR TRIBAL TATTOO DESIGN DEPICTING TWO WOLVES FACING ONE ANOTHER IN A HOWLING POSITION, SET AMONGST NUMEROUS INTERWOVEN LINES AND SHAPES AND ALL WITHIN THE CIRCLE.

FOR ADHESIVE TAPE FOR STATIONERY OR HOUSEHOLD PURPOSES; BOOKMARKS; CARDBOARD DOOR HANGERS; PENS; STICKERS; TRADING CARDS; ART PAPERS; ART PICTURES; CALENDARS; DECALS; DECORATIVE PAPER CENTERPIECES; ERASERS; GIFT CARDS; GREETING CARDS; KITS CONTAINING PARTY SUPPLIES, NAMELY, PAPER NAPKINS, PLASTIC UTENSILS, AND PAPER OR PLASTIC PLATES, CUPS, TABLE COVERS, AND DECORATIONS; LITHOGRAPHS; PAPER BANNERS; PAPER NAPKINS; PAPER PARTY DECORATIONS; PAPER PLACE MATS; PENCIL CASES; PENCILS; PHOTOGRAPHS MOUNTED AS LIFE-SIZE CUTOUTS; POSTERS; STATIONERY; AND TEMPORARY TATTOOS (U.S. CLS. 2, 5, 22, 23, 29, 37, 38 AND 50).

FIRST USE 11-0-2009; IN COMMERCE 11-0-2009.

CLASS 17—RUBBER GOODS

4,118,876. CRYOVAC, INC., ELMWOOD PARK, NJ. SN 77-603,842. PUB. 3-17-2009, FILED 10-30-2008.

PORTION-PULL

THE MARK CONSISTS OF STANDARD CHARACTERS WITHOUT CLAIM TO ANY PARTICULAR FONT, STYLE, SIZE, OR COLOR.

FOR PLASTIC FILMS FOR PACKAGING FOR INDUSTRIAL AND COMMERCIAL USE (U.S. CLS. 1, 5, 12, 13, 35 AND 50).

FIRST USE 8-1-2011; IN COMMERCE 8-1-2011.

CLASS 17—(Continued).

4,118,891. A. SCHULMAN, INC., AKRON, OH. SN 77-646,318. PUB. 10-20-2009, FILED 1-9-2009.

SCHULATEC

THE MARK CONSISTS OF STANDARD CHARACTERS WITHOUT CLAIM TO ANY PARTICULAR FONT, STYLE, SIZE, OR COLOR.

OWNER OF U.S. REG. NO. 2,675,992.

FOR DRY SOLID PLASTIC MATERIALS IN BULK POWDER, PELLET, GRANULE AND BEAD FORM FOR USE IN FURTHER PROCESSING BY THE PLASTICS MANUFACTURING INDUSTRY (U.S. CLS. 1, 5, 12, 13, 35 AND 50).

FIRST USE 4-4-2001; IN COMMERCE 4-1-2010.

4,119,464. GUARDIAN BUILDING PRODUCTS DISTRIBUTION, INC., GREENVILLE, SC. SN 85-215,388. PUB. 5-17-2011, FILED 1-11-2011.

FIBREGUARD

THE MARK CONSISTS OF STANDARD CHARACTERS WITHOUT CLAIM TO ANY PARTICULAR FONT, STYLE, SIZE, OR COLOR.

PRIORITY CLAIMED UNDER SEC. 44(D) ON ERPNCMNTY TM OFC APPLICATION NO. 009642174, FILED 1-6-2011.

FOR BUILDING INSULATION (U.S. CLS. 1, 5, 12, 13, 35 AND 50).

FIRST USE 1-0-2011; IN COMMERCE 1-0-2011.

4,119,706. CRYOVAC, INC., ELMWOOD PARK, NJ. SN 85-349,411. PUB. 10-18-2011, FILED 6-17-2011.

QuickRip

THE MARK CONSISTS OF "QUICKRIP" WITH A CURVED LINE ACROSS "QUICK".

FOR PLASTIC BAGS, POUCHES AND CASINGS FOR FOOD PRODUCTS INCLUDING FRESH RED MEAT, PORK, LAMB, POULTRY AND CHEESE FOR USE BY THE FOOD SERVICE INDUSTRY; PLASTIC FILM FOR COMMERCIAL AND INDUSTRIAL USE (U.S. CLS. 1, 5, 12, 13, 35 AND 50).

FIRST USE 12-29-2011; IN COMMERCE 12-29-2011.

CLASS 18—LEATHER GOODS

4,118,792. FEED PROJECTS LLC, NEW YORK, NY. SN 77-258,056. PUB. 6-1-2010, FILED 8-17-2007.



OWNER OF U.S. REG. NO. 3,526,344.
THE MARK CONSISTS OF THE WORD "FEED" IN STYLIZED FORM.
FOR LUGGAGE, HANDBAGS, CARRY BAGS, NAMELY, CARRY-ALL BAGS (U.S. CLS. 1, 2, 3, 22 AND 41).
FIRST USE 3-31-2007; IN COMMERCE 3-31-2007.

4,118,837. PUSSYCAT DOLLS, LLC, SANTA MONICA, CA. SN 77-480,521. PUB. 4-28-2009, FILED 5-21-2008.



THE MARK CONSISTS OF THE WORDS "PUSSYCAT DOLLS" WITHIN A HEART, WITH THE WORD "PUSSYCAT" PLACED ON A BANNER DISPLAYED ACROSS THE UPPER PART OF THE HEART, THE WORD "DOLLS" DISPLAYED ON THE HEART UNDER THE BANNER AND AN ORNAMENTAL DESIGN ON THE TOP OF THE HEART.

FOR LEATHER GOODS, NAMELY, PURSES; BRIEF-CASES; CREDIT CARD CASES; CARRYING CASES; BRIEFCASE-TYPE PORTFOLIOS; WALLETTS (U.S. CLS. 1, 2, 3, 22 AND 41).
FIRST USE 9-1-2005; IN COMMERCE 9-1-2005.

CLASS 18—(Continued).

4,119,015. AMERICAN RECREATION PRODUCTS, INC., CHESTERFIELD, MO. SN 77-926,213. PUB. 6-15-2010, FILED 2-2-2010.



THE MARK CONSISTS OF STANDARD CHARACTERS WITHOUT CLAIM TO ANY PARTICULAR FONT, STYLE, SIZE, OR COLOR.

FOR MOUNTAINEERING AND BACKPACKING EQUIPMENT, NAMELY, BACKPACKS, KNAPSACKS, BACKPACK FRAMES, PACK BAGS IN THE NATURE OF CARRY-ALL BAGS, DAY PACKS (U.S. CLS. 1, 2, 3, 22 AND 41).

FIRST USE 9-0-2011; IN COMMERCE 9-0-2011.

4,119,016. AMERICAN RECREATION PRODUCTS, INC., CHESTERFIELD, MO. SN 77-926,262. PUB. 6-15-2010, FILED 2-2-2010.



THE MARK CONSISTS OF STANDARD CHARACTERS WITHOUT CLAIM TO ANY PARTICULAR FONT, STYLE, SIZE, OR COLOR.

FOR MOUNTAINEERING AND BACKPACKING EQUIPMENT, NAMELY, BACKPACKS, KNAPSACKS, PACK BAGS IN THE NATURE OF CARRY-ALL BAGS, DAY PACKS (U.S. CLS. 1, 2, 3, 22 AND 41).

FIRST USE 9-0-2011; IN COMMERCE 9-0-2011.

4,119,126. OSPREY PACKS, INC., CORTEZ, CO. SN 85-050,719. PUB. 11-2-2010, FILED 5-28-2010.



OWNER OF U.S. REG. NOS. 2,571,330 AND 3,054,327.
THE STIPPLING IS A FEATURE OF THE MARK.

CLASS 18—(Continued).

THE MARK CONSISTS OF THE WORD "OSPREY" AND A STYLIZED DRAWING OF AN OSPREY WITH OUT-STRETCHED WINGS BELOW THE WORD.

FOR BACK FRAMES FOR CARRYING CHILDREN (U.S. CLS. 1, 2, 3, 22 AND 41).

FIRST USE 6-0-2011; IN COMMERCE 6-0-2011.

4,119,274. TRAVEL CADDY, INC., DBA TRAVELON, ELK GROVE VILLAGE, IL. SN 85-139,919. PUB. 3-8-2011, FILED 9-28-2010.

FLIP SIDE

THE MARK CONSISTS OF STANDARD CHARACTERS WITHOUT CLAIM TO ANY PARTICULAR FONT, STYLE, SIZE, OR COLOR.

FOR DAYPACKS, BACKPACKS, TOTE BAGS, MESSENGER BAGS (U.S. CLS. 1, 2, 3, 22 AND 41).

FIRST USE 7-0-2011; IN COMMERCE 7-0-2011.

4,119,357. SRY IMPORTS LLC, PORT WASHINGTON, NY. SN 85-189,272. PUB. 5-3-2011, FILED 12-2-2010.



NO CLAIM IS MADE TO THE EXCLUSIVE RIGHT TO USE "PACK", APART FROM THE MARK AS SHOWN.

THE MARK CONSISTS OF A RECTANGULAR PLAQUE WITH THE WORD "VIP" IN THE UPPER PORTION AND THE WORD "PAQ" IN THE LOWER PORTION AND A GEOMETRIC TRIANGLE DESIGN WITHIN.

FOR LUGGAGE (U.S. CLS. 1, 2, 3, 22 AND 41). FIRST USE 7-9-2011; IN COMMERCE 8-15-2011.

CLASS 18—(Continued).

4,119,358. SRY IMPORTS LLC, PORT WASHINGTON, NY. SN 85-189,339. PUB. 5-3-2011, FILED 12-2-2010.



NO CLAIM IS MADE TO THE EXCLUSIVE RIGHT TO USE "PACK", APART FROM THE MARK AS SHOWN.

THE MARK CONSISTS OF A RECTANGULAR PLAQUE WITH THE WORD "THE" IN THE UPPER PORTION AND THE WORD "PAQ" IN THE LOWER PORTION AND A GEOMETRIC TRIANGLE DESIGN WITHIN.

FOR CARRY-ON BAGS; LUGGAGE; TRAVEL BAGS (U.S. CLS. 1, 2, 3, 22 AND 41).

FIRST USE 7-9-2011; IN COMMERCE 8-15-2011.

4,119,637. DAYMEN CANADA ACQUISITION ULC, VANCOUVER, BC, CANADA. SN 85-295,161. PUB. 10-18-2011, FILED 4-14-2011.

QUICKSHELF

THE MARK CONSISTS OF STANDARD CHARACTERS WITHOUT CLAIM TO ANY PARTICULAR FONT, STYLE, SIZE, OR COLOR.

FOR CLIP BOARD INSERT SOLD AS AN INTEGRAL COMPONENT OF CARRYING BAGS, CASES AND BACKPACKS (U.S. CLS. 1, 2, 3, 22 AND 41).

FIRST USE 10-21-2011; IN COMMERCE 10-21-2011.

CLASS 19—NON-METALLIC BUILDING MATERIALS

4,118,757. LARA, JEFFREY PAYNE, NAVASOTA, TX. SN 76-700,576. PUB. 11-9-2010, FILED 11-27-2009.

TruForm Armatures

THE MARK CONSISTS OF STANDARD CHARACTERS WITHOUT CLAIM TO ANY PARTICULAR FONT, STYLE, SIZE, OR COLOR.

CLASS 19—(Continued).

NO CLAIM IS MADE TO THE EXCLUSIVE RIGHT TO USE "ARMATURES", APART FROM THE MARK AS SHOWN.

FOR SCULPTURES AND FIGURINES COMPOSED PRIMARILY OF A POLYMER FOAM MATERIAL AND THAT INCLUDE RIGID MEMBERS MADE OF THE POLYMER FOAM MATERIALS OR THE POLYMER FOAM MATERIALS IN COMBINATION WITH PLASTIC, PLASTER, METAL, OR COMBINATIONS THEREOF, ABLE TO BE CONNECTED TOGETHER USING MOVABLE MEMBERS MADE FROM ALUMINUM, OTHER METALS, WIRES, AND OTHER DUCTILE MATERIALS (U.S. CLS. 1, 12, 33 AND 50).

FIRST USE 4-15-2011; IN COMMERCE 4-15-2011.

4,118,778. STONCOR GROUP, INC., MAPLE SHADE, NJ. SN 77-093,447. PUB. 5-17-2011, FILED 1-29-2007.

STONLOK

THE MARK CONSISTS OF STANDARD CHARACTERS WITHOUT CLAIM TO ANY PARTICULAR FONT, STYLE, SIZE, OR COLOR.

OWNER OF U.S. REG. NO. 1,655,954.

FOR INTERLOCKING INDIVIDUAL FLOORING TILES MADE OF POLYVINYL CHLORIDE, SOLD BY APPLICANT'S CAPTIVE COMMISSIONED SALES PERSONS, AGENTS AND DISTRIBUTORS, FOR USE IN COMMERCIAL, INDUSTRIAL AND INSTITUTIONAL SETTINGS (U.S. CLS. 1, 12, 33 AND 50).

FIRST USE 10-31-2007; IN COMMERCE 10-31-2007.

4,118,920. GST INTERNATIONAL, LLC, SANTA ROSA, CA. SN 77-751,709. PUB. 10-20-2009, FILED 6-4-2009.

CLEANCRETE

THE MARK CONSISTS OF STANDARD CHARACTERS WITHOUT CLAIM TO ANY PARTICULAR FONT, STYLE, SIZE, OR COLOR.

FOR CONCRETE (U.S. CLS. 1, 12, 33 AND 50).
FIRST USE 6-1-2011; IN COMMERCE 6-1-2011.

CLASS 19—(Continued).

4,119,110. PACIFIC STAIR CORPORATION, SALEM, OR. SN 85-042,898. PUB. 4-26-2011, FILED 5-19-2010.

QUIET TREAD

THE MARK CONSISTS OF STANDARD CHARACTERS WITHOUT CLAIM TO ANY PARTICULAR FONT, STYLE, SIZE, OR COLOR.

NO CLAIM IS MADE TO THE EXCLUSIVE RIGHT TO USE "TREAD", APART FROM THE MARK AS SHOWN.

FOR STAIR TREADS NOT OF METAL (U.S. CLS. 1, 12, 33 AND 50).

FIRST USE 1-14-2010; IN COMMERCE 1-14-2010.

4,119,173. COLUMBIA INSURANCE COMPANY, OMAHA, NE. SN 85-073,557. PUB. 11-23-2010, FILED 6-29-2010.

DURATRU

THE MARK CONSISTS OF STANDARD CHARACTERS WITHOUT CLAIM TO ANY PARTICULAR FONT, STYLE, SIZE, OR COLOR.

FOR FLOORING, NAMELY, VINYL FLOORING (U.S. CLS. 1, 12, 33 AND 50).

FIRST USE 6-0-2010; IN COMMERCE 6-0-2010.

4,119,190. INTEPLAST GROUP, LTD., LIVINGSTON, NJ. SN 85-082,501. PUB. 5-17-2011, FILED 7-12-2010.

INTETRIM

THE MARK CONSISTS OF STANDARD CHARACTERS WITHOUT CLAIM TO ANY PARTICULAR FONT, STYLE, SIZE, OR COLOR.

THE WORDING "INTE" HAS NO MEANING IN A FOREIGN LANGUAGE.

FOR BUILDING MATERIALS, NAMELY, CELLULAR PVC TRIM (U.S. CLS. 1, 12, 33 AND 50).

FIRST USE 9-1-2011; IN COMMERCE 9-1-2011.

CLASS 19—(Continued).

4,119,191. INTEPLAST GROUP, LTD., LIVINGSTON, NJ. SN 85-082,638. PUB. 5-17-2011, FILED 7-12-2010.

INTE

THE MARK CONSISTS OF STANDARD CHARACTERS WITHOUT CLAIM TO ANY PARTICULAR FONT, STYLE, SIZE, OR COLOR.

THE WORDING "INTE" HAS NO MEANING IN A FOREIGN LANGUAGE.

FOR NONMETALLIC BUILDING MATERIALS, NAMELY, PLASTIC DECKING BOARDS, TRIMS, MOLDINGS (U.S. CLS. 1, 12, 33 AND 50).

FIRST USE 9-1-2011; IN COMMERCE 9-1-2011.

CLASS 19—(Continued).

4,119,319. EVERSEALED WINDOWS, INC., EVERGREEN, CO. SN 85-172,366. PUB. 5-10-2011, FILED 11-9-2010.

ESW

THE MARK CONSISTS OF STANDARD CHARACTERS WITHOUT CLAIM TO ANY PARTICULAR FONT, STYLE, SIZE, OR COLOR.

FOR INSULATING GLASS FOR BUILDING PURPOSES IN THE NATURE OF INSULATING GLASS FOR WINDOWS, DOORS AND SKYLIGHTS FOR BUILDING PURPOSES (U.S. CLS. 1, 12, 33 AND 50).

FIRST USE 12-30-2011; IN COMMERCE 12-30-2011.

4,119,225. JAMES HARDIE TECHNOLOGY LIMITED, DUBLIN 2, IRELAND. SN 85-104,089. PUB. 2-1-2011, FILED 8-10-2010.

PREVAIL

THE MARK CONSISTS OF STANDARD CHARACTERS WITHOUT CLAIM TO ANY PARTICULAR FONT, STYLE, SIZE, OR COLOR.

FOR BUILDING AND CONSTRUCTION MATERIAL, NAMELY, ENGINEERED CEMENT COMPOSITE PANELS, PLANKS AND BOARDS; FIBER-REINFORCED CEMENT COMPOSITES FOR BUILDING AND CONSTRUCTION, NAMELY, EXTERIOR CLADDING PANELS, PLANKS AND BOARDS (U.S. CLS. 1, 12, 33 AND 50).

FIRST USE 4-1-2010; IN COMMERCE 4-1-2010.

4,119,356. DURO-LAST, INC., SAGINAW, MI. SN 85-188,877. PUB. 5-3-2011, FILED 12-2-2010.

DURO-BLUE

THE MARK CONSISTS OF STANDARD CHARACTERS WITHOUT CLAIM TO ANY PARTICULAR FONT, STYLE, SIZE, OR COLOR.

OWNER OF U.S. REG. NOS. 1,798,975, 2,386,473, AND OTHERS.

FOR ROOFING UNDERLAYMENT (U.S. CLS. 1, 12, 33 AND 50).

FIRST USE 8-31-2010; IN COMMERCE 8-31-2010.

4,119,315. WOLFPAC TECHNOLOGIES, INC., ALIQUIPPA, PA. SN 85-169,347. PUB. 7-12-2011, FILED 11-4-2010.

VERSAWRAP

THE MARK CONSISTS OF STANDARD CHARACTERS WITHOUT CLAIM TO ANY PARTICULAR FONT, STYLE, SIZE, OR COLOR.

OWNER OF U.S. REG. NO. 3,077,495.

FOR BUILDING CONSTRUCTION ELEMENTS MADE PRIMARILY OF PLASTIC, NAMELY, EXTERIOR COVERINGS IN THE NATURE OF DECORATIVE TRIMS FOR POSTS AND SUPPORTS AND DECORATIVE TRIMS THAT ARE WRAPPED AROUND POSTS AND SUPPORTS (U.S. CLS. 1, 12, 33 AND 50).

FIRST USE 3-7-2011; IN COMMERCE 6-30-2011.

4,119,376. CIPEX INTERNATIONAL LIMITED, SANTA FE SPRINGS, CA. SN 85-196,022. PUB. 5-10-2011, FILED 12-12-2010.



OWNER OF U.S. REG. NO. 3,390,691.
NO CLAIM IS MADE TO THE EXCLUSIVE RIGHT TO USE "ALL TERRAIN" AND "STAGE", APART FROM THE MARK AS SHOWN.

CLASS 19—(Continued).

THE MARK CONSISTS OF THE IMAGE OF CIRCULAR BADGE WITH A STAR IN THE MIDDLE, WITH THE WORDING "INTELLI STAGE" APPEARING ABOVE AND BELOW THE STAR, AND THE WORDING "ALL TERRAIN" SUPERIMPOSED OVER THE BADGE ON A RECTANGULAR CARRIER.

FOR PORTABLE STAGES; STAGES FOR DISC JOCKEYS COMPOSED OF PRIMARILY NON-METAL MATERIALS; STAGES FOR MUSICAL PERFORMANCE COMPOSED OF PRIMARILY NON-METAL MATERIALS (U.S. CLS. 1, 12, 33 AND 50).

FIRST USE 0-0-2011; IN COMMERCE 0-0-2011.

CLASS 20—FURNITURE AND ARTICLES NOT OTHERWISE CLASSIFIED

4,118,753. FLOORCO ENTERPRISES, LLC, SHEPHERDSVILLE, KY. SN 76-685,743. PUB. 7-22-2008, FILED 1-14-2008.

HERITAGE HOUSE INTERNATIONAL

THE MARK CONSISTS OF STANDARD CHARACTERS WITHOUT CLAIM TO ANY PARTICULAR FONT, STYLE, SIZE, OR COLOR.

NO CLAIM IS MADE TO THE EXCLUSIVE RIGHT TO USE "INTERNATIONAL", APART FROM THE MARK AS SHOWN.

FOR BATHROOM ACCESSORIES, NAMELY, MIRRORS, MEDICINE CABINETS, AND VANITIES (U.S. CLS. 2, 13, 22, 25, 32 AND 50).

FIRST USE 2-17-2011; IN COMMERCE 2-17-2011.

4,118,775. DEL GRIPPO, GREGORY A., BEDMINSTER, NJ. SN 76-707,240. PUB. 9-20-2011, FILED 4-13-2011.

SPONGE STACK

THE MARK CONSISTS OF STANDARD CHARACTERS WITHOUT CLAIM TO ANY PARTICULAR FONT, STYLE, SIZE, OR COLOR.

NO CLAIM IS MADE TO THE EXCLUSIVE RIGHT TO USE "SPONGE", APART FROM THE MARK AS SHOWN.

FOR STORAGE RACK FOR ORGANIZING HOUSEHOLD CLEANING ARTICLES SUCH AS BRUSHES, WASH CLOTHS, SPONGES AND SOAP (U.S. CLS. 2, 13, 22, 25, 32 AND 50).

FIRST USE 1-9-2012; IN COMMERCE 1-9-2012.

CLASS 20—(Continued).

4,119,031. ORG, USA, INC., DBA MAISPACE, BUDD LAKE, NJ. SN 77-934,489. PUB. 5-17-2011, FILED 2-12-2010.

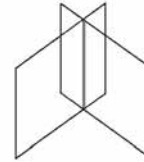

ALUR

THE MARK CONSISTS OF THE STYLIZED WORDING "ALUR" WITH THE DESIGN OF THE REPRESENTATION OF GLASS PANES CROSSING FORMED BY TWO INTERSECTING QUADRILATERALS.

FOR MOVABLE WALL PARTITIONS MADE PRIMARILY OF GLASS HAVING EXTRUDED ALUMINUM FRAMES AND ACRYLIC DRY JOINTS (U.S. CLS. 2, 13, 22, 25, 32 AND 50).

FIRST USE 3-9-2010; IN COMMERCE 3-9-2010.

4,119,041. DREAMWELL, LTD., LAS VEGAS, NV. SN 77-947,627. PUB. 6-22-2010, FILED 3-1-2010.

BEAUTYSOFT

THE MARK CONSISTS OF STANDARD CHARACTERS WITHOUT CLAIM TO ANY PARTICULAR FONT, STYLE, SIZE, OR COLOR.

FOR MATTRESSES AND BOX SPRINGS (U.S. CLS. 2, 13, 22, 25, 32 AND 50).

FIRST USE 11-1-2011; IN COMMERCE 11-1-2011.

4,119,278. NEELD, KEN, CHARLOTTE, NC. SN 85-140,546. PUB. 3-15-2011, FILED 9-29-2010.

SPORTY CLAUS

THE MARK CONSISTS OF STANDARD CHARACTERS WITHOUT CLAIM TO ANY PARTICULAR FONT, STYLE, SIZE, OR COLOR.

FOR CUSTOMIZED AND PAINTED PLASTIC MOLDED FIGURES OF SANTA CLAUS AND MRS. CLAUS (U.S. CLS. 2, 13, 22, 25, 32 AND 50).

FIRST USE 1-1-2008; IN COMMERCE 1-1-2008.

CLASS 20—(Continued).

4,119,457. VERVANO, LLC, AUSTIN, TX. SN 85-214,151. PUB. 5-24-2011, FILED 1-10-2011.



THE MARK CONSISTS OF A STYLIZED LETTER "V" WITH A PART OF IT LOOKING LIKE A LEAF INSIDE A DARKENED CIRCLE NEXT TO THE STYLIZED WORD "VERVANO".

FOR FURNITURE (U.S. CLS. 2, 13, 22, 25, 32 AND 50).
FIRST USE 8-31-2011; IN COMMERCE 8-31-2011.

4,119,589. KRUEGER INTERNATIONAL, INC., GREEN BAY, WI. SN 85-264,180. PUB. 6-21-2011, FILED 3-11-2011.

AMADEUS

THE MARK CONSISTS OF STANDARD CHARACTERS WITHOUT CLAIM TO ANY PARTICULAR FONT, STYLE, SIZE, OR COLOR.

FOR FURNITURE, NAMELY, TABLES, CREDENZAS (U.S. CLS. 2, 13, 22, 25, 32 AND 50).
FIRST USE 10-31-2011; IN COMMERCE 10-31-2011.

4,119,607. ZINUS INC., HAYWARD, CA. SN 85-276,044. PUB. 6-21-2011, FILED 3-24-2011.

Syntex

THE MARK CONSISTS OF STANDARD CHARACTERS WITHOUT CLAIM TO ANY PARTICULAR FONT, STYLE, SIZE, OR COLOR.

FOR BEDS, MATTRESSES, PILLOWS AND BOLSTERS; MATTRESS CUSHIONS; MATTRESS FOUNDATIONS; MATTRESS TOPPERS (U.S. CLS. 2, 13, 22, 25, 32 AND 50).
FIRST USE 12-1-2011; IN COMMERCE 1-1-2012.

CLASS 20—(Continued).

4,119,618. FOAMAROMA LLC, CAMAS, WA. SN 85-284,222. PUB. 8-9-2011, FILED 4-1-2011.

FOAMAROMA

THE MARK CONSISTS OF STANDARD CHARACTERS WITHOUT CLAIM TO ANY PARTICULAR FONT, STYLE, SIZE, OR COLOR.

FOR PLASTIC LIDS (U.S. CLS. 2, 13, 22, 25, 32 AND 50).
FIRST USE 3-11-2011; IN COMMERCE 12-9-2011.

4,119,623. SHANGHAI CARESSING HOME PRODUCTS CO., LTD., SHANGHAI, CHINA. SN 85-288,475. PUB. 8-16-2011, FILED 4-7-2011.



THE MARK CONSISTS OF THE STYLIZED WORD "BESTCH" WITH THE CHARACTER "B", THREE CHINESE CHARACTERS WHICH TRANSLITERATE INTO BAI SI JIA UNDER THE WORD "BESTCH" AND A BUTTERFLY DESIGN ON THE LEFT, IN WHICH THE RIGHT SIDE OF THE BUTTERFLY DESIGN IS FORMED BY THE LETTER "B" OF THE WORD "BESTCH".

THE WORDING "BESTCH" HAS NO MEANING IN A FOREIGN LANGUAGE.

THE NON-LATIN CHARACTERS IN THE MARK TRANSLITERATE TO BAI; SI; JIA AND THIS MEANS "HUNDRED", "THINK" AND "EXCELLENT" IN ENGLISH.

FOR BEDS; CHAIRS; CUSHIONS; FURNITURE; MASSAGE TABLES; MATTRESSES; PET CUSHIONS; PILLOWS; SOFAS; SPRING MATTRESSES (U.S. CLS. 2, 13, 22, 25, 32 AND 50).

FIRST USE 11-25-2008; IN COMMERCE 9-1-2011.

CLASS 20—(Continued).

4,119,666. NOMACORC, LLC, ZEBULON, NC. SN 85-310,532. PUB. 10-25-2011, FILED 5-3-2011.

SELECT

THE MARK CONSISTS OF STANDARD CHARACTERS WITHOUT CLAIM TO ANY PARTICULAR FONT, STYLE, SIZE, OR COLOR.

FOR SYNTHETIC POLYMER EXTRUSIONS FOR USE AS CLOSURES FOR BOTTLES; SYNTHETIC CORK OR CORK IMITATION STOPPERS FOR BOTTLES (U.S. CLS. 2, 13, 22, 25, 32 AND 50).

FIRST USE 10-1-2010; IN COMMERCE 1-5-2011.

CLASS 21—(Continued).

4,119,090. RYAN, PATRICK CLARKSON, NEWPORT, RI. SN 85-029,318. PUB. 5-24-2011, FILED 5-4-2010.

 The logo for CleanCare features the word "CleanCare" in a bold, sans-serif font. A four-pointed star is positioned in the upper right corner of the letter "C" in "Care". Two curved lines, one above "Clean" and one below "Care", intersect at the star.

THE MARK CONSISTS OF THE WORDING "CLEAN-CARE" IN CONJUNCTION WITH A DESIGN ELEMENT. A FOUR-POINT STAR SHAPE APPEARS IN THE CROOK OF THE LETTER "C" IN "CARE". THE DESIGN ELEMENT ALSO FEATURES TWO CURVED LINES, ONE FORMING A SLIGHT ARC ABOVE THE WORDING "CLEAN" AND ONE FORMING A SLIGHT ARC BELOW THE WORDING "CARE". EACH CURVED LINE INTERSECTS THE LETTER "C" IN THE WORDING "CARE" AND THE TWO LINES NEARLY MEET AT THE FOUR-POINT STAR.

FOR DENTAL FLOSS; TOOTHBRUSHES (U.S. CLS. 2, 13, 23, 29, 30, 33, 40 AND 50).

FIRST USE 1-11-2012; IN COMMERCE 1-11-2012.

CLASS 21—HOUSEWARES AND GLASS

4,119,030. DISNEY ENTERPRISES, INC., BURBANK, CA. SN 77-933,823. PUB. 11-30-2010, FILED 2-11-2010.

TANGLED

THE MARK CONSISTS OF STANDARD CHARACTERS WITHOUT CLAIM TO ANY PARTICULAR FONT, STYLE, SIZE, OR COLOR.

FOR BEVERAGeware; BOWLS; CUPS; DINNERWARE; DISHES; HAIR BRUSHES; HOUSEHOLD CONTAINERS FOR FOOD AND BEVERAGES; LUNCH BOXES; PLASTIC CUPS; PLATES; SPORTS BOTTLES SOLD EMPTY (U.S. CLS. 2, 13, 23, 29, 30, 33, 40 AND 50).

FIRST USE 1-31-2011; IN COMMERCE 1-31-2011.

4,119,467. TOAS-TITE LLC, DR. HOFFMAN ESTATES, IL. SN 85-215,904. PUB. 5-24-2011, FILED 1-12-2011.



THE MARK CONSISTS OF AN ARTISTIC RENDERING OF A WOMAN HOLDING A SANDWICH.

FOR REPLICAS OF A SPECIALIZED NON-ELECTRIC COOKING APPLIANCE FIRST SOLD IN THE 1940'S AND UTILIZED PRIMARILY FOR MAKING SANDWICHES (U.S. CLS. 2, 13, 23, 29, 30, 33, 40 AND 50).

FIRST USE 10-31-2011; IN COMMERCE 10-31-2011.

CLASS 21—(Continued).

4,119,609. SAFE TV SHOP, LLC, CHARLOTTE, NC. SN 85-276,391. PUB. 5-31-2011, FILED 3-24-2011.



THE MARK CONSISTS OF THE WORD "EGGIES" IN A DISTINCTIVE FONT, WHERE THE LOWER CASE LETTER "E" IS MODIFIED TO RESEMBLE THE APPLICANT'S EGG SHELL SHAPED COOKWARE.

FOR COOKWARE FOR USE IN BOILING WATER, NAMELY, PLASTIC EGG SHELL SHAPED COOKWARE FOR USE IN COOKING EGGS (U.S. CLS. 2, 13, 23, 29, 30, 33, 40 AND 50).

FIRST USE 5-24-2011; IN COMMERCE 5-24-2011.

CLASS 22—(Continued).

4,119,026. BOINGY LLC, TIGARD, OR. SN 77-930,743. PUB. 6-22-2010, FILED 2-8-2010.



THE MARK CONSISTS OF STANDARD CHARACTERS WITHOUT CLAIM TO ANY PARTICULAR FONT, STYLE, SIZE, OR COLOR.

FOR TETHERS IN THE NATURE OF RUBBER CORDS THAT ARE SECURED BY A SUCTION CUP TO A FLAT SURFACE TO HOLD CHILDREN'S TOYS AND UTENSILS (U.S. CLS. 1, 2, 7, 19, 22, 42 AND 50).

FIRST USE 9-23-2011; IN COMMERCE 9-23-2011.

4,119,682. KIMBERLY-CLARK WORLDWIDE, INC., NEENAH, WI. SN 85-325,625. PUB. 8-23-2011, FILED 5-20-2011.



THE MARK CONSISTS OF STANDARD CHARACTERS WITHOUT CLAIM TO ANY PARTICULAR FONT, STYLE, SIZE, OR COLOR.

FOR DISPENSERS FOR PAPER TOWELS, PAPER TISSUE AND SKIN CARE SOAPS AND CLEANSERS (U.S. CLS. 2, 13, 23, 29, 30, 33, 40 AND 50).

FIRST USE 12-30-2011; IN COMMERCE 12-30-2011.

CLASS 24—FABRICS

4,118,844. ASICS CORPORATION, CHUO-KU, KOBE, JAPAN. SN 77-493,719. PUB. 10-28-2008, FILED 6-8-2008.



THE MARK CONSISTS OF STANDARD CHARACTERS WITHOUT CLAIM TO ANY PARTICULAR FONT, STYLE, SIZE, OR COLOR.

FOR WOVEN AND KNITTED TEXTILE FABRICS MADE WHOLLY OR PARTLY OF SYNTHETIC FIBER AND USED FOR MANUFACTURE OF CLOTHING (U.S. CLS. 42 AND 50).

FIRST USE 5-1-2011; IN COMMERCE 5-1-2011.

4,119,704. HEWY WINE CHILLERS, LLC, ORLANDO, FL. SN 85-346,507. PUB. 10-18-2011, FILED 6-15-2011.



THE MARK CONSISTS OF THE STYLIZED WORD "CORKCICLE", WHICH APPEARS IN ALL CAPS FOLLOWED BY THE PERIOD SYMBOL.

FOR BOTTLE STOPPERS SPECIALLY ADAPTED FOR USE WITH WINE BOTTLES; COOLERS FOR WINE (U.S. CLS. 2, 13, 23, 29, 30, 33, 40 AND 50).

FIRST USE 9-20-2011; IN COMMERCE 9-20-2011.

4,119,119. THE MARCIA E. HORSTMAN AND JONATHAN W. HORSTMAN PARTNERSHIP, CULLOWHEE, NC. SN 85-046,443. PUB. 10-19-2010, FILED 5-24-2010.



THE MARK CONSISTS OF STANDARD CHARACTERS WITHOUT CLAIM TO ANY PARTICULAR FONT, STYLE, SIZE, OR COLOR.

FOR BED COVERS AND BED LINENS (U.S. CLS. 42 AND 50).

FIRST USE 7-4-2011; IN COMMERCE 7-4-2011.

CLASS 22—CORDAGE AND FIBERS

CLASS 24—(Continued).

4,119,138. HEBEI YIKANG KNITTING AND COTTON, LTD., SHIJIAZHUANG, CHINA. SN 85-055,651. PUB. 11-30-2010, FILED 6-5-2010.



THE COLOR(S) BLUE, GREEN, ORANGE, PASTEL VERMILLION, RED, BLACK AND WHITE IS/ARE CLAIMED AS A FEATURE OF THE MARK.

THE MARK CONSISTS OF A DESIGN OF RAINBOW WHICH IS FOLDED AT ONE END COMPRISED OF THE COLORS BLUE, GREEN, ORANGE, PASTEL VERMILLION AND RED; WITH A DESIGN OF A BALL OF COTTON IN THE COLOR RED WITH A VERTICAL STRIPE IN THE COLOR WHITE RUNNING THROUGH THE BALL OF COTTON DESIGN. THE LETTERS "YK" ARE SHOWN IN THE COLOR BLACK AND APPEAR BELOW THE RAINBOW DESIGN.

FOR BANNERS AND FLAGS OF TEXTILE; BED AND TABLE LINEN; WALL HANGINGS OF TEXTILE; COVERED RUBBER YARN FABRICS; CURTAIN LOOPS OF TEXTILE MATERIAL; CURTAINS MADE OF TEXTILE FABRICS; CURTAINS OF TEXTILE; CURTAINS OF TEXTILE OR PLASTIC; FABRIC FINISH OR SURFACE TREATMENT COMPOSITION SOLD AS A COMPONENT OF FINISHED TREATED OR COATED TEXTILES AND FABRICS TO ENHANCE PRINTING OF DESIGNS AND PATTERNS THEREON; FABRIC FINISH OR SURFACE TREATMENT COMPOSITION SOLD AS A COMPONENT OF FINISHED TREATED OR COATED TEXTILES AND FABRICS TO PRESERVE COLOR DYES AND INKS THEREON AND TO REDUCE OR ELIMINATE FADE; FABRICS THAT MAY OR MAY NOT HAVE PRINTED PATTERNS AND DESIGNS THEREON FOR USE IN TEXTILE APPLICATIONS, NAMELY, THE MANUFACTURE OF APPAREL, UPHOLSTERY, SIGNAGE, FLAGS, BANNERS AND WALLPAPER; FACE TOWELS; FACE TOWELS OF TEXTILES; HAND TOWELS OF TEXTILE; HAND-TOWELS MADE OF TEXTILE FABRICS; HANDKERCHIEFS OF TEXTILE; HANDKERCHIEFS OF TEXTILES; MOISTURE ABSORBENT MICROFIBER TEXTILE FABRICS FOR USE IN THE MANUFACTURE OF ATHLETIC APPAREL, NAMELY, SHIRTS, PANTS, SHORTS, JACKETS, BAGS, TOWELS AND ATHLETIC UNIFORMS; NATURAL AND SYNTHETIC FABRICS AND TEXTILES, NAMELY, COTTON, SILK, POLYESTER AND NYLON FABRICS; NON-WOVEN TEXTILE FABRICS; PLACE MATS OF TEXTILE MATERIAL; PRINTED TEXTILE LABELS; QUILTS OF TEXTILE; TABLE CLOTH OF TEXTILE; TABLE LINEN OF TEXTILE; TABLECLOTHS OF TEXTILES; TEXTILE FABRICS FOR THE MANUFACTURE OF CLOTHING; TEXTILE FABRICS FOR USE IN MAKING CLOTHING AND HOUSEHOLD FURNISHINGS; TEXTILE FABRICS FOR USE IN THE MANUFACTURE OF GARMENTS, BAGS, JACKETS, GLOVES, AND APPAREL; TEXTILE HANDKERCHIEFS; TEXTILE SUBSTITUTE MATERIALS MADE FROM SYNTHETIC MATERIALS; TEXTILE TABLECLOTHS; TEXTILE TISSUES FOR REMOVING MAKE-UP; TEXTILE USED AS LINING FOR CLOTHING; TOWELS; TOWELS MADE OF TEXTILE MATERIALS; UNFITTED SEAT COVERS OF TEXTILE (U.S. CLS. 42 AND 50).

FIRST USE 8-22-2011; IN COMMERCE 12-29-2011.

CLASS 24—(Continued).

4,119,156. IWAN SIMONIS, INC., LIBERTYVILLE, IL. SN 85-065,423. PUB. 11-16-2010, FILED 6-17-2010.

SIMONIS 760

THE MARK CONSISTS OF STANDARD CHARACTERS WITHOUT CLAIM TO ANY PARTICULAR FONT, STYLE, SIZE, OR COLOR.

OWNER OF U.S. REG. NO. 1,395,774.
FOR BILLIARD CLOTH; WOOLEN CLOTH (U.S. CLS. 42 AND 50).
FIRST USE 6-19-2000; IN COMMERCE 6-19-2000.

4,119,157. IWAN SIMONIS, INC., LIBERTYVILLE, IL. SN 85-065,461. PUB. 11-16-2010, FILED 6-17-2010.

SIMONIS 860

THE MARK CONSISTS OF STANDARD CHARACTERS WITHOUT CLAIM TO ANY PARTICULAR FONT, STYLE, SIZE, OR COLOR.

OWNER OF U.S. REG. NO. 1,395,774.
FOR BILLIARD CLOTH; WOOLEN CLOTH (U.S. CLS. 42 AND 50).
FIRST USE 6-19-2000; IN COMMERCE 6-19-2000.

4,119,158. IWAN SIMONIS, INC., ARLINGTON HEIGHTS, IL. SN 85-065,485. PUB. 11-16-2010, FILED 6-17-2010.

SIMONIS 860HR

THE MARK CONSISTS OF STANDARD CHARACTERS WITHOUT CLAIM TO ANY PARTICULAR FONT, STYLE, SIZE, OR COLOR.

OWNER OF U.S. REG. NO. 1,395,774.
FOR BILLIARD CLOTH; WOOLEN CLOTH (U.S. CLS. 42 AND 50).
FIRST USE 6-19-2000; IN COMMERCE 6-19-2000.

CLASS 24—(Continued).

4,119,297. KINGDOM BUILDER'S PRAYER INSTITUTE, HOUSTON, TX. SN 85-154,900. PUB. 5-24-2011, FILED 10-18-2010.

BABY WRAPPED IN THE WORD

THE MARK CONSISTS OF STANDARD CHARACTERS WITHOUT CLAIM TO ANY PARTICULAR FONT, STYLE, SIZE, OR COLOR.

NO CLAIM IS MADE TO THE EXCLUSIVE RIGHT TO USE "BABY", APART FROM THE MARK AS SHOWN.

FOR BLANKETS, NAMELY, BABY BLANKETS WITH BIBLE VERSES AND BIBLE SCRIPTURES INSCRIBED ON THEM (U.S. CLS. 42 AND 50).

FIRST USE 3-1-2011; IN COMMERCE 3-1-2011.

CLASS 25—CLOTHING

4,118,750. WEIDER HEALTH AND FITNESS, WOODLAND HILLS, CA. SN 76-558,330. PUB. 5-4-2010, FILED 11-10-2003.

JOE WEIDER

OWNER OF U.S. REG. NOS. 1,485,344 AND 2,836,887. THE NAME "JOE WEIDER" IDENTIFIES A LIVING INDIVIDUAL WHOSE CONSENT IS OF RECORD.

FOR MEN'S, WOMEN'S AND CHILDREN'S APPAREL, NAMELY, SHIRTS, T-SHIRTS AND HEADWEAR (U.S. CLS. 22 AND 39).

FIRST USE 2-5-2011; IN COMMERCE 2-5-2011.

CLASS 25—(Continued).

4,118,751. MYERS, WILLIAM, NEW YORK, NY. SN 76-619,018. PUB. 10-4-2005, FILED 11-1-2004.

WHO DAT

THE MARK CONSISTS OF STANDARD CHARACTERS WITHOUT CLAIM TO ANY PARTICULAR FONT, STYLE, SIZE, OR COLOR.

FOR APPAREL FOR WOMEN, MEN, TEEN GIRLS AND TEEN BOYS, NAMELY, BIKINIS; BEACH WEAR, NAMELY, GYM SHORTS, HALTERTOPS, JOGGING SUITS, LEGGINGS, POLO SHIRTS, PONCHOS, SHORTS, SKIRTS, SWEAT SUITS, SWEAT SHIRTS; CASUAL WEAR, NAMELY, BLOUSES, DUNGAREES, JEANS; WOMEN'S APPAREL, NAMELY, DRESSES, MINI SKIRTS; WOMEN'S LINGERIE, NAMELY, BUSTIERS; MEN'S CLOTHING, NAMELY, SHORTS (U.S. CLS. 22 AND 39).

FIRST USE 12-8-2004; IN COMMERCE 12-8-2004.

4,118,764. TLB HOLDINGS, INC., PLYMOUTH, MN. SN 76-704,470. PUB. 3-8-2011, FILED 9-13-2010.

M.I.N.N.E.

THE MARK CONSISTS OF THE WORDING "M.I.N.N.E." IN STYLIZED FONT.

THE WORDING "M.I.N.N.E." HAS NO MEANING IN A FOREIGN LANGUAGE.

FOR WOMEN'S CLOTHING, NAMELY, SHIRTS, T-SHIRTS, SWEATERS, PANTS, HATS, CAPS, COATS AND JACKETS (U.S. CLS. 22 AND 39).

FIRST USE 12-31-2010; IN COMMERCE 12-31-2010.

4,118,769. WIESNER PRODUCTS, INC., NEW YORK, NY. SN 76-705,619. PUB. 5-31-2011, FILED 12-9-2010.

LITTLE PRINCESS

THE MARK CONSISTS OF STANDARD CHARACTERS WITHOUT CLAIM TO ANY PARTICULAR FONT, STYLE, SIZE, OR COLOR.

OWNER OF U.S. REG. NOS. 1,760,711 AND 2,756,626. FOR CHILDREN'S UNDERWEAR, PANTIES, AND BRAS (U.S. CLS. 22 AND 39).

FIRST USE 1-1-2011; IN COMMERCE 1-1-2011.

CLASS 25—(Continued).

4,118,772. TIFFANY J. BURRESS, TOTOWA, NJ. SN 76-706,282. PUB. 9-20-2011, FILED 2-4-2011.



THE MARK CONSISTS OF THE STYLIZED LETTERS "J" & "M" WITH THE LETTERS COMING TOGETHER TO FORM A HIGHLY STYLIZED HEART.

FOR MATERNITY CLOTHING AND WEAR, NAMELY, DRESSES, SUITS, T-SHIRTS, JUMPERS, TROUSERS, BLOUSES, SKIRTS, JACKETS, DUNGAREES, JEANS, CARDIGANS, SWEAT SUITS, JOGGING SUITS, MUFFLERS, HEADBANDS, HALTER TOPS, SMOCK TOPS, SKI PANTS, SHAWLS, PONCHOS, SHOULDER WRAPS, NECKERCHIEFS; MATERNITY SWIMWEAR, NAMELY, BATHING SUITS, COVER-UPS; MATERNITY RAINWEAR, NAMELY, RAINCOATS; MATERNITY HOSIERY, NAMELY, STOCKINGS, SOCKS, TIGHTS, LEGGINGS, LEOTARDS; MATERNITY SLEEPWEAR, NAMELY, NIGHTGOWNS, PAJAMAS, MATERNITY SLIPS; MATERNITY LINGERIE, NAMELY, PANTIES, BRAS; FOOTWEAR AND HEADWEAR (U.S. CLS. 22 AND 39).

FIRST USE 12-0-2011; IN COMMERCE 12-0-2011.

4,118,788. TRIMARCHI, HELENE, BROOKLYN, NY. AND MERR, MICHAEL, BROOKLYN, NY. SN 77-222,086. PUB. 6-23-2009, FILED 7-4-2007.



THE COLOR(S) PINK, BLACK AND WHITE IS/ARE CLAIMED AS A FEATURE OF THE MARK.

THE MARK CONSISTS OF AN OVAL SHAPE DIVIDED IN THE CENTER BY A WAVE-SHAPE, SOMEWHAT LIKE A YIN AND YANG SYMBOL, WITH PINK AS THE LEFT SIDE AND BLACK AS THE RIGHT, WITH A BLACK LINE COMING OFF THE CENTER INTO THE PINK SIDE AND SMALL CIRCLE CREATING AN ARM AND HEAD IMAGE OF A FEMALE PERSONA, WITH WHITE LETTERS ACROSS BOTH SIDES OF THE OVAL.

THE FOREIGN WORDING IN THE MARK TRANSLATES INTO ENGLISH AS GO GIRLS!

FOR GOLF SHIRTS; POLO SHIRTS; SHIRTS; SHORT-SLEEVED OR LONG-SLEEVED T-SHIRTS; SHORT-SLEEVED SHIRTS; SPORT SHIRTS; SPORTS SHIRTS WITH SHORT SLEEVES; SWEAT SHIRTS; T-SHIRTS; YOGA SHIRTS (U.S. CLS. 22 AND 39).

FIRST USE 12-15-2011; IN COMMERCE 1-31-2012.

CLASS 25—(Continued).

4,118,805. LAWRENCE, CARLY, JAMESTOWN, IN. SN 77-349,819. PUB. 11-25-2008, FILED 12-12-2007.

RACE BUM

THE MARK CONSISTS OF STANDARD CHARACTERS WITHOUT CLAIM TO ANY PARTICULAR FONT, STYLE, SIZE, OR COLOR.

FOR CLOTHING, NAMELY, T-SHIRTS, JACKETS, HATS AND CAPS (U.S. CLS. 22 AND 39).

FIRST USE 1-14-2012; IN COMMERCE 1-14-2012.

4,118,812. MAXEY, AVA LISA, SHERWOOD, AR. SN 77-381,933. PUB. 6-17-2008, FILED 1-28-2008.

LIFE IS A NOW THING

THE MARK CONSISTS OF STANDARD CHARACTERS WITHOUT CLAIM TO ANY PARTICULAR FONT, STYLE, SIZE, OR COLOR.

FOR TOPS; CAPS; JERSEYS; SHIRTS (U.S. CLS. 22 AND 39).

FIRST USE 7-1-2011; IN COMMERCE 7-1-2011.

4,118,822. ACME CLOTHING CORPORATION, OXFORD, CT. SN 77-437,260. PUB. 11-16-2010, FILED 4-1-2008.



NO CLAIM IS MADE TO THE EXCLUSIVE RIGHT TO USE "JEANS", APART FROM THE MARK AS SHOWN.

THE COLOR(S) YELLOW, BLACK, WHITE, GREY, RED IS/ARE CLAIMED AS A FEATURE OF THE MARK.

THE MARK CONSISTS OF A YELLOW OVAL OUTLINED IN BLACK ENCLOSING THE DESIGN OF A ROOSTER WITH GREY WINGS OUTLINED IN BLACK, BLACK CLAWS, A RED PLUME AND EYES, BOTH OUTLINED AND ACCENTED IN BLACK, A YELLOW BEAK AND WHITE TEETH, BOTH OUTLINED IN BLACK, A BLACK HEAD, AND THE WORDING "COCK JEANS" IN BLACK ABOVE THE ROOSTER'S CLAWS.

FOR JEANS (U.S. CLS. 22 AND 39).

FIRST USE 6-1-2010; IN COMMERCE 6-1-2010.

CLASS 25—(Continued).

4,118,845. ASICS CORPORATION, CHUO-KU, KOBE, JAPAN. SN 77-493,754. PUB. 10-28-2008, FILED 6-8-2008.

PGuard

THE MARK CONSISTS OF THE LETTERS "PGUARD" FOR FOOTWEAR (U.S. CLS. 22 AND 39). FIRST USE 5-1-2011; IN COMMERCE 5-1-2011.

4,118,846. WASHINGTON TEAM TENNIS LLC, WASHINGTON, DC. SN 77-494,715. PUB. 10-28-2008, FILED 6-9-2008.

WASHINGTON KASTLES

THE MARK CONSISTS OF STANDARD CHARACTERS WITHOUT CLAIM TO ANY PARTICULAR FONT, STYLE, SIZE, OR COLOR.

NO CLAIM IS MADE TO THE EXCLUSIVE RIGHT TO USE "WASHINGTON", APART FROM THE MARK AS SHOWN.

FOR CLOTHING, NAMELY, T-SHIRTS, SWEATSHIRTS, POLO SHIRTS, SHORTS, BASEBALL HATS, VISORS, TENNIS WEAR, SWEATBANDS, PONCHOS (U.S. CLS. 22 AND 39).

FIRST USE 7-0-2008; IN COMMERCE 7-0-2008.

4,118,848. WASHINGTON TEAM TENNIS LLC, WASHINGTON, DC. SN 77-494,752. PUB. 11-4-2008, FILED 6-9-2008.



THE MARK CONSISTS OF AN IMAGE OF A KNIGHT WEARING A SHIELD WITH THREE STARS ABOVE A CASTLE, AND A TENNIS RACKET AND TENNIS BALL LOCATED ON EACH SIDE OF THE SHIELD.

FOR CLOTHING, NAMELY, T-SHIRTS, SWEATSHIRTS, POLO SHIRTS, SHORTS, BASEBALL HATS, VISORS, TENNIS WEAR, SWEATBANDS, PONCHOS (U.S. CLS. 22 AND 39).

FIRST USE 7-0-2008; IN COMMERCE 7-0-2008.

CLASS 25—(Continued).

4,118,859. NINJAI GANG, LLC, KAILUA, HI. SN 77-504,732. PUB. 10-14-2008, FILED 6-20-2008.

DEMON SHREDDERS

THE MARK CONSISTS OF STANDARD CHARACTERS WITHOUT CLAIM TO ANY PARTICULAR FONT, STYLE, SIZE, OR COLOR.

OWNER OF U.S. REG. NO. 2,498,549. FOR CLOTHING, NAMELY, SHIRTS, HEADWEAR, JOGGING SUITS, AND SOCKS (U.S. CLS. 22 AND 39). FIRST USE 4-16-2008; IN COMMERCE 4-16-2008.

4,118,887. 72 BLUE, INC., MISSOULA, MT. SN 77-643,156. PUB. 4-28-2009, FILED 1-5-2009.

SECOND AND BRIDGE

THE MARK CONSISTS OF STANDARD CHARACTERS WITHOUT CLAIM TO ANY PARTICULAR FONT, STYLE, SIZE, OR COLOR.

FOR CLOTHING, NAMELY, SHIRTS AND SWEATSHIRTS, ALL FOR MEN, WOMEN, AND CHILDREN (U.S. CLS. 22 AND 39).

FIRST USE 3-25-2011; IN COMMERCE 3-25-2011.

4,118,913. COLUMBIA INSURANCE COMPANY, OMAHA, NE. SN 77-729,255. PUB. 9-22-2009, FILED 5-5-2009.

HALLØ

THE MARK CONSISTS OF STANDARD CHARACTERS WITHOUT CLAIM TO ANY PARTICULAR FONT, STYLE, SIZE, OR COLOR.

FOR FOOTWEAR AND CLOTHING, NAMELY, SOCKS, HOSIERY, BELTS, DRESSES, GLOVES, NECKWEAR, SWIMWEAR, SKIRTS, UNDERWEAR, WRISTBANDS, AND SCARVES (U.S. CLS. 22 AND 39).

FIRST USE 6-5-2009; IN COMMERCE 6-5-2009.

CLASS 25—(Continued).

4,118,938. CLAUDIU CO., LTD., SHIBUYA-KU, TOKYO, JAPAN. SN 77-813,127. PUB. 5-18-2010, FILED 8-26-2009.

K·O·W

THE MARK CONSISTS OF CAPITAL LETTERS "KOW" WITH A ROUND DOT CENTERED BETWEEN THE "K" AND THE "O" AND ANOTHER ROUND DOT CENTERED BETWEEN THE "O" AND THE "W".

FOR CLOTHING, NAMELY, COATS, SWEATERS, SHIRTS; HEADGEAR, NAMELY, CAPS AND HATS; BELTS FOR CLOTHING; NON-JAPANESE STYLE OUTER CLOTHING NAMELY, JACKETS (U.S. CLS. 22 AND 39).

FIRST USE 1-1-2002; IN COMMERCE 10-15-2011.

4,118,949. ROLDEN TRUST, DURBAN, KWA ZULU NATAL, SOUTH AFRICA. SN 77-843,215. PUB. 2-15-2011, FILED 10-7-2009.

FOR YOUR GROWING NEEDS

THE MARK CONSISTS OF STANDARD CHARACTERS WITHOUT CLAIM TO ANY PARTICULAR FONT, STYLE, SIZE, OR COLOR.

FOR MATERNITY WEAR, NAMELY, FEEDING SHIRTS, FEEDING BRASSIERES, CLOTHING EXTENSION AND SUPPORT DEVICES, NAMELY, BELTS, FOR USE DURING PREGNANCY, AND CLOTHING EXTENSIONS USED TO EXTEND THE NORMAL SIZE RANGE OF CLOTHING ITEMS TO ACCOMMODATE PREGNANCY SIZE CHANGES (U.S. CLS. 22 AND 39).

FIRST USE 7-0-2008; IN COMMERCE 7-0-2008.

4,118,953. THE EXAMPLE FOR LEADING OUR NATION LLC, ATLANTA, GA. SN 77-850,662. PUB. 4-19-2011, FILED 10-16-2009.

PRESIDENTIAL FITS

THE MARK CONSISTS OF STANDARD CHARACTERS WITHOUT CLAIM TO ANY PARTICULAR FONT, STYLE, SIZE, OR COLOR.

CLASS 25—(Continued).

NO CLAIM IS MADE TO THE EXCLUSIVE RIGHT TO USE "FITS", APART FROM THE MARK AS SHOWN.

FOR T-SHIRTS, FLEECE PULLOVERS; HOODED SWEAT SHIRTS; KNIT SHIRTS; MEN'S UNDERWEAR; POLO SHIRTS; RUGBY SHIRTS; SWEATERS; SWIM WEAR (U.S. CLS. 22 AND 39).

FIRST USE 6-1-2008; IN COMMERCE 6-1-2008.

4,118,957. PEDERSON, SCOTT, ROSWELL, GA. SN 77-864,496. PUB. 10-19-2010, FILED 11-4-2009.

POSITIVE ATHLETE

THE MARK CONSISTS OF STANDARD CHARACTERS WITHOUT CLAIM TO ANY PARTICULAR FONT, STYLE, SIZE, OR COLOR.

NO CLAIM IS MADE TO THE EXCLUSIVE RIGHT TO USE "ATHLETE", APART FROM THE MARK AS SHOWN.

FOR BANDANAS; BELTS; CAPS; CHILDREN'S AND INFANT'S APPAREL, NAMELY, JUMPERS, OVERALL SLEEPWEAR, PAJAMAS, ROMPERS AND ONE-PIECE GARMENTS; HATS; HEAD SWEATBANDS; HOODED SWEAT SHIRTS; JACKETS; JERSEYS; PANTS; SCARVES; SHIRTS; SHORT SETS; SHORTS; SWEAT JACKETS; SWEAT PANTS; SWEAT SHIRTS; SWEAT SHORTS; SWEAT SUITS; SWEATERS; T-SHIRTS; TIES; TOPS; UNDER GARMENTS; VESTS; VISORS; WRISTBANDS (U.S. CLS. 22 AND 39).

FIRST USE 9-1-2011; IN COMMERCE 9-1-2011.

4,118,965. KAHN LUCAS LANCASTER, INC., NEW YORK, NY. SN 77-875,244. PUB. 4-20-2010, FILED 11-18-2009.

MIMIKO

THE MARK CONSISTS OF STANDARD CHARACTERS WITHOUT CLAIM TO ANY PARTICULAR FONT, STYLE, SIZE, OR COLOR.

FOR GIRL'S APPAREL, NAMELY, DRESSES, TOPS, PANTS, SKIRTS, SEPARATELY AND IN SETS (U.S. CLS. 22 AND 39).

FIRST USE 12-1-2011; IN COMMERCE 12-1-2011.

CLASS 25—(Continued).

4,118,968. JIMENEZ AYUD, ANTONIO, DBA JIMENEZ AYUD, ANTONIO, TORREMOLINOS, MALAGA, SPAIN. SN 77-879,501. PUB. 12-28-2010, FILED 11-24-2009.

WORLD-DANCERS WD

THE MARK CONSISTS OF STANDARD CHARACTERS WITHOUT CLAIM TO ANY PARTICULAR FONT, STYLE, SIZE, OR COLOR.
FOR SHOES (U.S. CLS. 22 AND 39).
FIRST USE 8-4-2009; IN COMMERCE 8-4-2009.

4,119,002. ALBERT, JOSHUA P, ZEELAND, MI. SN 77-913,738. PUB. 6-1-2010, FILED 1-18-2010.

JET CADET

THE MARK CONSISTS OF STANDARD CHARACTERS WITHOUT CLAIM TO ANY PARTICULAR FONT, STYLE, SIZE, OR COLOR.
FOR SHIRTS; T-SHIRTS; TEE SHIRTS (U.S. CLS. 22 AND 39).
FIRST USE 12-12-2011; IN COMMERCE 12-12-2011.

4,119,003. REED, KYM, PALO ALTO, CA. SN 77-916,273. PUB. 7-27-2010, FILED 1-20-2010.

GLAMGERIE

THE MARK CONSISTS OF STANDARD CHARACTERS WITHOUT CLAIM TO ANY PARTICULAR FONT, STYLE, SIZE, OR COLOR.
FOR UNDERGARMENTS; INTIMATE APPAREL, NAMELY, BRAS, CAMISOLES, UNDERWEAR, PANTIES, CAMISOLE AND PANTY SETS, TEDDIES, BABY DOLL PAJAMAS, SLIPS AND NIGHTIES (U.S. CLS. 22 AND 39).
FIRST USE 8-2-2011; IN COMMERCE 8-2-2011.

CLASS 25—(Continued).

4,119,049. EULIE LLC, PROVIDENCE, RI. SN 77-982,797. PUB. 3-23-2010, FILED 7-2-2009.

SEXY. PERIOD.

THE MARK CONSISTS OF STANDARD CHARACTERS WITHOUT CLAIM TO ANY PARTICULAR FONT, STYLE, SIZE, OR COLOR.
FOR CLOTHING, NAMELY, PANTIES, UNDERPANTS, UNDERWEAR; STAIN-RESISTANT AND STAIN-REPELLANT CLOTHING, NAMELY, PANTIES, UNDERPANTS, UNDERWEAR (U.S. CLS. 22 AND 39).
FIRST USE 9-23-2010; IN COMMERCE 1-31-2011.

4,119,054. SEARS BRANDS, LLC, HOFFMAN ESTATES, IL. SN 77-982,942. PUB. 6-15-2010, FILED 2-1-2010.

AMPLIFY

THE MARK CONSISTS OF STANDARD CHARACTERS WITHOUT CLAIM TO ANY PARTICULAR FONT, STYLE, SIZE, OR COLOR.
FOR APPAREL, NAMELY, TOPS, BOTTOMS, SHIRTS, SWEATERS, PANTS, JEANS, SHORTS, JACKETS, COATS, SWIMWEAR; CLOTHING ACCESSORIES, NAMELY, SOCKS, HATS, BELTS (U.S. CLS. 22 AND 39).
FIRST USE 7-0-2010; IN COMMERCE 7-0-2010.

4,119,059. DANNER, INC., PORTLAND, OR. SN 78-800,432. PUB. 9-30-2008, FILED 1-26-2006.

STRIKER

THE MARK CONSISTS OF STANDARD CHARACTERS WITHOUT CLAIM TO ANY PARTICULAR FONT, STYLE, SIZE, OR COLOR.
FOR FOOTWEAR; CLOTHING, NAMELY, SOCKS AND T-SHIRTS (U.S. CLS. 22 AND 39).
FIRST USE 7-31-2001; IN COMMERCE 7-31-2001.

CLASS 25—(Continued).

4,119,072. JS IP LLC, AVENTURA, FL. SN 85-006,415. PUB. 11-30-2010, FILED 4-5-2010.

FONTAINEBLEAU

THE MARK CONSISTS OF STANDARD CHARACTERS WITHOUT CLAIM TO ANY PARTICULAR FONT, STYLE, SIZE, OR COLOR.
OWNER OF U.S. REG. NOS. 3,061,814, 3,164,415, AND OTHERS.

FOR WEARING APPAREL, NAMELY, SHIRTS, T-SHIRTS, HATS, CAPS, VISORS, SWEATSHIRTS, BEACH SANDALS (U.S. CLS. 22 AND 39).

FIRST USE 11-14-2008; IN COMMERCE 11-14-2008.

4,119,115. HILLEY, CONNIE J., ROSSVILLE, GA. SN 85-045,473. PUB. 5-10-2011, FILED 5-21-2010.



THE COLOR(S) BLACK, BLUE AND RED IS/ARE CLAIMED AS A FEATURE OF THE MARK.

THE MARK CONSISTS OF THE WORDING "READY", EYE DESIGNS APPEARING IN THE LETTERS "A" AND "D" IN "READY" AND OF A WAVY LINE REPRESENTING THE SMILE DESIGN BENEATH THE "A" AND "D".

FOR LINGERIE (U.S. CLS. 22 AND 39).
FIRST USE 11-17-2000; IN COMMERCE 5-26-2003.

4,119,118. INTELLITOONZ ENTERTAINMENT LLC, HILLSBOROUGH, NJ. SN 85-046,363. PUB. 10-26-2010, FILED 5-24-2010.



THE COLOR(S) BLUE, LIGHT BLUE, PURPLE, GREEN, DARK GREEN, YELLOW, BLACK, RED, BROWN, ORANGE, TAN, WHITE, PINK IS/ARE CLAIMED AS A FEATURE OF THE MARK.

THE MARK CONSISTS OF A WHITE DOG IN BLACK OUTLINE WITH BLACK EYES AND WHISKERS WEARING

CLASS 25—(Continued).

A BLUE DRESS WITH PURPLE AND GREEN DOTS; TAN BALLERINA WITH BROWN HAIR WITH A PURPLE TUTU AND PINK BALLET SLIPPERS WAVING A RED AND BLACK WAND WITH ORANGE RAYS COMING FROM IT; A TAN MOUSE WITH BLACK HAIR, EYES AND WHISKERS WEARING A BLUE SHIRT, RED BOW TIE, BLACK PANTS AND GOLD BELT BUCKLE AND BLACK SHOES; DARK GREEN AND GREEN TURTLE WITH BLACK AND EYES; AND A YELLOW BUTTERFLY, OUTLINED IN BLACK WITH LIGHT BLUE WING EDGES AND RED, ORANGE, YELLOW, PINK, BLUE, LIGHT BLUE, GREEN, AND DARK GREEN INNER WINGS.

FOR HATS; PANTS; SHIRTS; SHOES; SHORTS; SWEAT SHIRTS; UNDERWEAR (U.S. CLS. 22 AND 39).

FIRST USE 11-0-2011; IN COMMERCE 11-0-2011.

4,119,142. SHARON YOUNG INC., DALLAS, TX. SN 85-058,262. PUB. 2-8-2011, FILED 6-9-2010.

Alli Y

THE MARK CONSISTS OF STANDARD CHARACTERS WITHOUT CLAIM TO ANY PARTICULAR FONT, STYLE, SIZE, OR COLOR.

THE NAME(S), PORTRAIT(S), AND/OR SIGNATURE(S) SHOWN IN THE MARK DOES NOT IDENTIFY A PARTICULAR LIVING INDIVIDUAL.

FOR CLOTHING, NAMELY, SKIRTS, JACKETS, BLOUSES, SWEATERS, PANTS, VESTS, SKORTS, DRESSES, SHIRTS (U.S. CLS. 22 AND 39).

FIRST USE 1-1-2011; IN COMMERCE 1-1-2011.

4,119,155. MICHAEL RIVERA, PORT JEFFERSON STATION, NY. SN 85-065,156. PUB. 11-16-2010, FILED 6-17-2010.

REVELATION 7

THE MARK CONSISTS OF STANDARD CHARACTERS WITHOUT CLAIM TO ANY PARTICULAR FONT, STYLE, SIZE, OR COLOR.

FOR APPAREL, NAMELY, T-SHIRTS, PANTS, SHORTS, POLOS, BOXERS, SOCKS, SNEAKERS, TIES, HATS, BELTS, SWIMSUITS, SKIRTS, BUTTON DOWN SHIRTS, DRESSES, TANK TOPS, AND SUITS (U.S. CLS. 22 AND 39).

FIRST USE 12-25-2011; IN COMMERCE 12-25-2011.

CLASS 25—(Continued).

4,119,164. GOOD AND FAIR CLOTHING LLC, AUSTIN, TX. SN 85-068,781. PUB. 5-17-2011, FILED 6-22-2010.



THE COLOR(S) RED AND GREY IS/ARE CLAIMED AS A FEATURE OF THE MARK.

THE MARK CONSISTS OF GREY LETTERS FOR THE WORDS "GOOD", "FAIR"; THE COLOR RED FOR THE "&". FOR BOTTOMS; CLOTHING, NAMELY, BASE LAYERS; MUFFLERS; TOPS; WEARABLE GARMENTS AND CLOTHING, NAMELY, SHIRTS (U.S. CLS. 22 AND 39).

FIRST USE 11-6-2010; IN COMMERCE 11-6-2010.

CLASS 25—(Continued).

4,119,195. TARGET BRANDS, INC., MINNEAPOLIS, MN. SN 85-085,407. PUB. 12-21-2010, FILED 7-15-2010.



THE MARK CONSISTS OF STANDARD CHARACTERS WITHOUT CLAIM TO ANY PARTICULAR FONT, STYLE, SIZE, OR COLOR.

OWNER OF U.S. REG. NOS. 1,074,619 AND 2,690,799. FOR WOMEN'S APPAREL, NAMELY, ROBES, WRAPS; SLIPPERS (U.S. CLS. 22 AND 39).

FIRST USE 10-30-2011; IN COMMERCE 10-30-2011.

4,119,167. SHERIDAN, PATRICK, LOS ANGELES, CA. SN 85-070,228. PUB. 11-16-2010, FILED 6-23-2010.



THE MARK CONSISTS OF STANDARD CHARACTERS WITHOUT CLAIM TO ANY PARTICULAR FONT, STYLE, SIZE, OR COLOR.

FOR SHIRTS; T-SHIRTS (U.S. CLS. 22 AND 39).

FIRST USE 3-21-2011; IN COMMERCE 1-3-2012.

4,119,197. LUXXE, INC., BOCA RATON, FL. SN 85-086,810. PUB. 4-26-2011, FILED 7-16-2010.

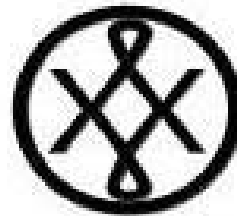

4,119,178. SNASHALL, THOMAS, BINGHAMTON, NY. SN 85-074,413. PUB. 5-31-2011, FILED 6-29-2010.



THE MARK CONSISTS OF STANDARD CHARACTERS WITHOUT CLAIM TO ANY PARTICULAR FONT, STYLE, SIZE, OR COLOR.

FOR SHIRTS (U.S. CLS. 22 AND 39).

FIRST USE 8-16-2009; IN COMMERCE 8-22-2011.

THE NAME "LUXXE" DOES NOT IDENTIFY A LIVING INDIVIDUAL.

THE MARK CONSISTS OF TWO STYLIZED, INTERSECTING "X"'S CONTAINED WITHIN A CIRCLE ABOVE THE WORD "LUXXE".

THE WORDING "LUXXE" HAS NO MEANING IN A FOREIGN LANGUAGE.

FOR CLOTHING, EXERCISE WEAR, EVENING WEAR, SHAPEWEAR AND RESORT WEAR, NAMELY, TOPS, BOTTOMS, SHIRTS, PANTS, JEANS, SWEATERS, SKIRTS, DRESSES, SUITS, PANTSUITS, COATS, BELTS, FOOTWEAR, HEAD WEAR, SHOES, JACKETS, BRAS, UNDERGARMENTS, LEOTARDS, BIKINIS, WRAPS, PAREOS, COVER UPS AND SWIM WEAR (U.S. CLS. 22 AND 39).

FIRST USE 1-21-2010; IN COMMERCE 1-21-2010.

CLASS 25—(Continued).

4,119,202. DAVID & GOLIATH LLC, EL SEGUNDO, CA. SN 85-089,171. PUB. 12-28-2010, FILED 7-21-2010.



THE MARK CONSISTS OF A SHIELD DIVIDED INTO FOUR SECTIONS WITH THE UPPER LEFT AND LOWER RIGHT SECTIONS FILLED IN AND THE LOWER LEFT AND UPPER RIGHT SECTIONS WITH DIAGONAL LINES MOVING UPWARD FROM LEFT TO RIGHT.

FOR CLOTHING, NAMELY, SHIRTS, HATS, CAPS, SWEATSHIRTS (U.S. CLS. 22 AND 39).

FIRST USE 6-5-2008; IN COMMERCE 6-5-2008.

4,119,211. WUXI JUNZHENG TRADING CO., LTD., JIANGSU PROVINCE, CHINA. SN 85-096,457. PUB. 5-10-2011, FILED 7-30-2010.



Octopus Paul
章魚保羅

THE MARK CONSISTS OF A CIRCLE CONTAINING AN OCTOPUS WEARING A CROWN. BELOW THE DESIGN OF THE OCTOPUS IS THE WORDING "OCTOPUS PAUL" AND BELOW THIS ARE FOUR CHINESE CHARACTERS THAT TRANSLITERATE INTO "ZHANG YU BAO LUO".

THE ENGLISH TRANSLATION OF THE CHINESE CHARACTERS IS "OCTOPUS PAUL".

THE NON-LATIN CHARACTERS IN THE MARK TRANSLITERATE TO "ZHANG YU BAO LUO".

FOR DRESSES; FOOTWEAR; HEADWEAR; HOSIERY; JACKETS; SHIRTS; SKIRTS; T-SHIRTS; TROUSERS (U.S. CLS. 22 AND 39).

FIRST USE 7-30-2010; IN COMMERCE 7-30-2010.

CLASS 25—(Continued).

4,119,226. PROTREND, LTD., COMMERCE, CA. SN 85-104,630. PUB. 1-25-2011, FILED 8-10-2010.

HONESTEE

THE MARK CONSISTS OF STANDARD CHARACTERS WITHOUT CLAIM TO ANY PARTICULAR FONT, STYLE, SIZE, OR COLOR.

FOR CLOTHING, NAMELY, BLOUSES (U.S. CLS. 22 AND 39).

FIRST USE 12-30-2011; IN COMMERCE 12-30-2011.

4,119,230. DILTEX, S.A. DE C.V., DE JUAREZ, EDO. DE, MEXICO. SN 85-106,478. PUB. 1-25-2011, FILED 8-12-2010.

OWNER OF U.S. REG. NO. 2,249,819.

THE MARK CONSISTS OF THE LITERAL ELEMENT "ILUSION" AND A FIGURATIVE DESIGN OF A ROSE.

THE ENGLISH TRANSLATION OF "ILUSION" IN THE MARK IS ILLUSION.

FOR LINGERIE, UNDERWEAR, BRAS, BODYSUITS, CHEMISES, CAMISOLES, SLIPS, CORSETS, BODICES, SLEEPWEAR, HOODED SWEATSHIRTS, SHIRTS, JACKETS, SWIMWEAR, SHORTS, BLOUSES, T-SHIRTS, TANK TOPS, JEANS, PANTS, DRESSES, SWEAT PANTS, LEGGINGS (U.S. CLS. 22 AND 39).

FIRST USE 1-0-2010; IN COMMERCE 1-0-2010.

4,119,252. DENNIS, TINA, MAMARONECK, NY. SN 85-122,706. PUB. 5-10-2011, FILED 9-3-2010.

THE MARK CONSISTS OF THE WORD "INAPPROPRIATE" IN STYLIZED FORM WITH A DRAWING OF A WOMAN'S EYE TO THE RIGHT OF IT.

FOR DRESSES; JACKETS; PANTS; SHIRTS; SWEATERS; TOPS (U.S. CLS. 22 AND 39).

FIRST USE 11-30-2010; IN COMMERCE 11-30-2010.

CLASS 25—(Continued).

4,119,265. LYNCH STANFORD R, HYDE PARK, MA. SN 85-132,618. PUB. 3-8-2011, FILED 9-17-2010.



THE COLOR(S) GREEN, YELLOW, AND BLACK IS/ARE CLAIMED AS A FEATURE OF THE MARK.

THE MARK CONSISTS OF A CIRCLE ENCLCING THE LETTERS "S" AND "I" WITH THE OUTLINE OF THE CIRCLE AND THE RIGHT OF THE CIRCLE IN BLACK, THE LEFT OF THE CIRCLE IN GREEN AND THE LETTERS "S" AND "I" IN YELLOW. BENEATH THE CIRCLE APPEARS THE WORDING "SIMPLY IRIE" IN BLACK.

THE ENGLISH TRANSLATION OF THE WORD "IRIE" IN THE MARK IS "GOOD FEELING".

FOR APPAREL FOR DANCERS, NAMELY, TEE SHIRTS, SWEATSHIRTS, PANTS, LEGGINGS, SHORTS AND JACKETS; AQUA SHOES; ATHLETIC APPAREL, NAMELY, SHIRTS, PANTS, JACKETS, FOOTWEAR, HATS AND CAPS, ATHLETIC UNIFORMS; ATHLETIC SHOES; BASEBALL SHOES; BEACH SHOES; BOAT SHOES; BODY SHIRTS; BOWLING SHOES; BOXING SHOES; BUTTON DOWN SHIRTS; CLIMBING SHOES; CLOTHING FOR ATHLETIC USE, NAMELY, PADDED PANTS; CLOTHING FOR ATHLETIC USE, NAMELY, PADDED SHIRTS; COLLARED SHIRTS; DENIMS; DRESS SHIRTS; FISHING SHIRTS; FOOTBALL SHOES; GOLF PANTS, SHIRTS AND SKIRTS; GOLF SHIRTS; GOLF SHOES; GYM PANTS; GYMNASIIC SHOES; HOCKEY SHOES; HOODED SWEAT SHIRTS; HUNTING PANTS; HUNTING SHIRTS; INFANTS' SHOES AND BOOTS; LEATHER PANTS; LEATHER SHIRTS; LONG-SLEEVED SHIRTS; NIGHT SHIRTS; NURSE PANTS; OPEN-NECKED SHIRTS; OVER SHIRTS; PANTS; POLO SHIRTS; RIDING SHOES; RUNNING PADS THAT STRAP ONTO SHOES; RUNNING SHOES; SANDALS AND BEACH SHOES; SCIENTIFIC AND TECHNOLOGICAL APPAREL, NAMELY, SHIRTS, PANTS, JACKETS, FOOTWEAR, HATS AND CAPS, UNIFORMS; SHIRT FRONTS; SHIRTS AND SHORT-SLEEVED SHIRTS; SHIRTS FOR INFANTS, BABIES, TODDLERS AND CHILDREN; SHOES; SHOES SOLES FOR REPAIR; SHORT-SLEEVED OR LONG-SLEEVED T-SHIRTS; SHORT-SLEEVED SHIRTS; SKI AND SNOWBOARD SHOES AND PARTS THEREOF; SKI PANTS; SKIING SHOES; SLEEP PANTS; SLEEP SHIRTS; SLEEVES WORN SEPARATE AND APART FROM BLOUSES, SHIRTS AND OTHER TOPS; SNOW PANTS; SNOWBOARD PANTS; SOCCER SHOES; SPORT SHIRTS; SPORTS PANTS; SPORTS SHIRTS; SPORTS SHIRTS WITH SHORT SLEEVES; SWEAT PANTS; SWEAT SHIRTS; T-SHIRTS; TEE SHIRTS; TENNIS SHOES; TRACK AND FIELD SHOES; TRACK PANTS; TRAINING SHOES; TRAVEL CLOTHING CONTAINED IN A PACKAGE COMPRISING REVERSIBLE JACKETS, PANTS, SKIRTS, TOPS AND A BELT OR SCARF; TRIATHLON CLOTHING, NAMELY, TRIATHLON TIGHTS, TRIATHLON SHORTS, TRIATHLON SINGLETTS, TRIATHLON SHIRTS, TRIATHLON SUITS; TURTLE NECK SHIRTS; VOLLEYBALL SHOES; WATERPROOF JACKETS AND PANTS; WATERPROOF LEATHER SHOES; WATERPROOF LEATHER SHOES AND BOOTS; WIND PANTS; WOMEN'S SHOES (U.S. CLS. 22 AND 39).

FIRST USE 8-8-2011; IN COMMERCE 8-8-2011.

CLASS 25—(Continued).

4,119,281. DASH CLOTHING, INC., NEW YORK, NY. SN 85-142,847. PUB. 3-15-2011, FILED 10-1-2010.

DASH BOARD

THE MARK CONSISTS OF STANDARD CHARACTERS WITHOUT CLAIM TO ANY PARTICULAR FONT, STYLE, SIZE, OR COLOR.

FOR BELTS; BELTS FOR CLOTHING; BERMUDA SHORTS; BOXER SHORTS; BRIEFS; COLLARED SHIRTS; CREW NECK SWEATERS; DRESS SHIRTS; JUMPERS; LONG-SLEEVED SHIRTS; MEN'S UNDERWEAR; MOCK TURTLE-NECK SWEATERS; OPEN-NECKED SHIRTS; OVERALLS; PANTS; POLO SHIRTS; RAINCOATS; SHIRTS; SHIRTS AND SHORT-SLEEVED SHIRTS; SHORT-SLEEVED OR LONG-SLEEVED T-SHIRTS; SHORT-SLEEVED SHIRTS; SHORTS; SWEATERS; T-SHIRTS; TEE SHIRTS; TURTLENECK SWEATERS; UNDERGARMENTS; UNDERWEAR; UNDERWEAR, NAMELY, BOY SHORTS; V-NECK SWEATERS; WAIST BELTS (U.S. CLS. 22 AND 39).

FIRST USE 6-15-2011; IN COMMERCE 12-1-2011.

4,119,286. NITE BEAM PRODUCTS, LLC, CHARLOTTE, NC. SN 85-147,933. PUB. 3-8-2011, FILED 10-7-2010.

Double Vision

THE MARK CONSISTS OF STANDARD CHARACTERS WITHOUT CLAIM TO ANY PARTICULAR FONT, STYLE, SIZE, OR COLOR.

FOR HATS (U.S. CLS. 22 AND 39).

FIRST USE 11-1-2010; IN COMMERCE 11-1-2011.

4,119,287. MILES, DAVID, WINFIELD, AL. SN 85-148,906. PUB. 3-15-2011, FILED 10-8-2010.

NO WON LEFT BEHIND

THE MARK CONSISTS OF STANDARD CHARACTERS WITHOUT CLAIM TO ANY PARTICULAR FONT, STYLE, SIZE, OR COLOR.

FOR CAPS; JERSEYS; PANTS; SHIRTS; SHORTS; SOCKS (U.S. CLS. 22 AND 39).

FIRST USE 7-4-2011; IN COMMERCE 7-4-2011.

CLASS 25—(Continued).

4,119,308. KAHN LUCAS LANCASTER, INC., NEW YORK, NY. SN 85-161,101. PUB. 3-22-2011, FILED 10-26-2010.

FANCY THAT

THE MARK CONSISTS OF STANDARD CHARACTERS WITHOUT CLAIM TO ANY PARTICULAR FONT, STYLE, SIZE, OR COLOR.

FOR GIRLS' APPAREL, NAMELY, DRESSES, SKIRTS, PANTS, AND TOPS (U.S. CLS. 22 AND 39).
FIRST USE 12-1-2011; IN COMMERCE 12-1-2011.

4,119,314. DANA DESHUN AKBAR, CEDAR HILL, TX. AND DARCUS DEON ROBERSON, CEDAR HILL, TX. SN 85-167,440. PUB. 7-12-2011, FILED 11-2-2010.

Fancy Me Couture

THE MARK CONSISTS OF STANDARD CHARACTERS WITHOUT CLAIM TO ANY PARTICULAR FONT, STYLE, SIZE, OR COLOR.

NO CLAIM IS MADE TO THE EXCLUSIVE RIGHT TO USE "COUTURE", APART FROM THE MARK AS SHOWN.

FOR ALL APPAREL, NAMELY, TOPS, BLOUSES, SHOES, STILETTOS, PUMPS, SANDALS, FLATS, PANTS, JEANS, DRESSES, HATS, APPAREL, LEGGINGS, SHORTS, SKIRTS, BOOTS, BOOTIES, SOCKS, UNDERGARMENTS, SWEATERS, GLOVES, SCARVES, COATS, JACKETS, BOLERO, TUNICS, SWEATERS, TANKS, JOGGING PANTS AND JOGGING TOPS, SWEATS, CAPRIS, SUITS, HOODED SWEATSHIRTS, STOCKINGS, TIGHTS (U.S. CLS. 22 AND 39).

FIRST USE 8-1-2011; IN COMMERCE 12-23-2011.

4,119,321. MUST HAVE PRODUCTS, INC., MEQUON, WI. SN 85-174,524. PUB. 5-3-2011, FILED 11-11-2010.

COZY CAPE

THE MARK CONSISTS OF STANDARD CHARACTERS WITHOUT CLAIM TO ANY PARTICULAR FONT, STYLE, SIZE, OR COLOR.

NO CLAIM IS MADE TO THE EXCLUSIVE RIGHT TO USE "CAPE", APART FROM THE MARK AS SHOWN.

FOR CAPES FOR USE IN HAIR SALONS FOR PROTECTING CLOTHING AND SKIN WHILE RECEIVING SALON SERVICES (U.S. CLS. 22 AND 39).

FIRST USE 10-3-2011; IN COMMERCE 10-3-2011.

CLASS 25—(Continued).

4,119,328. WILLIAMS, STEVE, WESTON, FL. SN 85-178,382. PUB. 4-26-2011, FILED 11-16-2010.

HAS BEEN ATHLETICS

THE MARK CONSISTS OF STANDARD CHARACTERS WITHOUT CLAIM TO ANY PARTICULAR FONT, STYLE, SIZE, OR COLOR.

NO CLAIM IS MADE TO THE EXCLUSIVE RIGHT TO USE "ATHLETICS", APART FROM THE MARK AS SHOWN.

FOR ATHLETIC APPAREL, NAMELY, SHIRTS, PANTS, JACKETS, FOOTWEAR, HATS AND CAPS, ATHLETIC UNIFORMS; JERSEYS; SHORT-SLEEVED OR LONG-SLEEVED T-SHIRTS; WEARABLE GARMENTS AND CLOTHING, NAMELY, SHIRTS (U.S. CLS. 22 AND 39).

FIRST USE 10-1-2011; IN COMMERCE 10-1-2011.

4,119,351. CAPRICO LLC, AVON, CO. SN 85-187,864. PUB. 5-24-2011, FILED 12-1-2010.

SOMETHING GOOD

THE MARK CONSISTS OF STANDARD CHARACTERS WITHOUT CLAIM TO ANY PARTICULAR FONT, STYLE, SIZE, OR COLOR.

FOR A-SHIRTS; BABY BODYSUITS; BABY BOTTOMS; BABY TOPS; BODY LINEN; BODY SHAPERS; CHILDREN'S AND INFANTS' CLOTH BIBS; CHILDREN'S CLOTH EATING BIBS; CLOTH BIBS; CLOTHING ITEMS, NAMELY, ADHESIVE POCKETS THAT MAY BE AFFIXED DIRECTLY TO THE BODY AS A DECORATIVE PIECE OF CLOTHING WITH UTILITY; GIFT PACKAGES SOLD AS A UNIT CONSISTING PRIMARILY OF A SWEATSHIRT AND ALSO INCLUDING A PHOTO FRAME, A COFFEE MUG, AND A TOTE BAG; HATS FOR INFANTS, BABIES, TODDLERS AND CHILDREN; HOODED SWEAT SHIRTS; HOODED SWEATSHIRTS; INFANT AND TODDLER ONE PIECE CLOTHING; NIGHT SHIRTS; NIGHTSHIRTS; ONE PIECE GARMENT FOR INFANTS AND TODDLERS; OPEN-NECKED SHIRTS; PLASTIC BABY BIBS; SCARVES; SHIRTS FOR INFANTS, BABIES, TODDLERS AND CHILDREN; SHORT-SLEEVED OR LONG-SLEEVED T-SHIRTS; SLEEP SHIRTS; SPORTS SHIRTS WITH SHORT SLEEVES; SWEAT SHIRTS; SWEATSHIRTS; T-SHIRTS; TEE SHIRTS; WEARABLE GARMENTS AND CLOTHING, NAMELY, SHIRTS; WOMEN'S HATS AND HOODS; WOMEN'S TOPS, NAMELY, CAMIS (U.S. CLS. 22 AND 39).

FIRST USE 1-1-2011; IN COMMERCE 1-1-2011.

CLASS 25—(Continued).

4,119,368. VAN DER VEER, KAREN, FLAGSTAFF, AZ. SN 85-193,765. PUB. 4-19-2011, FILED 12-9-2010.

KARMALICIOUS

THE MARK CONSISTS OF STANDARD CHARACTERS WITHOUT CLAIM TO ANY PARTICULAR FONT, STYLE, SIZE, OR COLOR.

FOR CLOTHING, NAMELY, FASHION AND ATHLETIC APPAREL, NAMELY, TOPS, BOTTOMS, T-SHIRTS, SWEATSHIRTS, SKIRTS, PANTS, UNDERWEAR, FOOTWEAR, HEADWEAR, DRESSES, JACKETS, COATS, BELTS, NECKWEAR, BEACHWEAR, AND SLEEPWEAR (U.S. CLS. 22 AND 39).

FIRST USE 11-11-2010; IN COMMERCE 6-24-2011.

4,119,372. ROLFES, JUDD, CLARKDALE, AZ. SN 85-194,707. PUB. 5-10-2011, FILED 12-9-2010.



NO CLAIM IS MADE TO THE EXCLUSIVE RIGHT TO USE "EST. 1876", APART FROM THE MARK AS SHOWN.

THE MARK CONSISTS OF THE STYLIZED LETTERS "UJ" BEHIND THE STYLIZED WORDING "UNIVERSITY OF JEROME". UNDERNEATH IS THE WORDING "EST. 1876".

FOR JACKETS; PANTS; SHIRTS; SHORTS; SWEATERS (U.S. CLS. 22 AND 39).

FIRST USE 6-15-2011; IN COMMERCE 6-15-2011.

4,119,382. SAEDI, SAMAN, BEVERLY HILLS, CA. SN 85-197,193. PUB. 5-24-2011, FILED 12-14-2010.

MADE IN HEAVEN INTIMATES

THE MARK CONSISTS OF STANDARD CHARACTERS WITHOUT CLAIM TO ANY PARTICULAR FONT, STYLE, SIZE, OR COLOR.

OWNER OF U.S. REG. NO. 3,076,501.

CLASS 25—(Continued).

NO CLAIM IS MADE TO THE EXCLUSIVE RIGHT TO USE "INTIMATES", APART FROM THE MARK AS SHOWN.

FOR BATHING SUITS; BEACH COVER-UPS; BELTS; BLOUSES; BRAS; CAMISOLES; CAPRI PANTS; CAPS; CARDIGANS; COATS; DENIM JACKETS; DENIMS; DRESSES; GARTER BELTS; HATS; JACKETS; JEANS; LINGERIE; NIGHTIES; NIGHTWEAR; PAJAMAS; PANTIES, SHORTS AND BRIEFS; PANTS; PANTYHOSE; ROBES; SCARVES; SHAWLS; SHIRTS; SHOES; SHORTS; SKIRTS; SLACKS; SLIPS; SOCKS; STOCKINGS; SWEAT JACKETS; SWEAT PANTS; SWEAT SHIRTS; SWEAT SHORTS; SWEAT SUITS; SWEATERS; T-SHIRTS; TANK TOPS; TUNICS; UNDERWEAR (U.S. CLS. 22 AND 39).

FIRST USE 10-17-2011; IN COMMERCE 10-17-2011.

4,119,385. DESCENTE NORTH AMERICA, INC., LAYTON, UT. SN 85-197,491. PUB. 5-3-2011, FILED 12-14-2010.



THE MARK CONSISTS OF A DOUBLE HELIX ABOVE THE LETTERS "DNE".

FOR SKI AND SNOWBOARD CLOTHING, NAMELY, SHIRTS, T-SHIRTS, JACKETS, PANTS, AND HATS; CLOTHING, NAMELY, SHIRTS, T-SHIRTS, JACKETS, PANTS (U.S. CLS. 22 AND 39).

FIRST USE 8-15-2011; IN COMMERCE 8-15-2011.

4,119,418. PACIFIC SUNWEAR OF CALIFORNIA, INC., ANAHEIM, CA. SN 85-202,945. PUB. 5-10-2011, FILED 12-21-2010.

C&S

THE MARK CONSISTS OF STANDARD CHARACTERS WITHOUT CLAIM TO ANY PARTICULAR FONT, STYLE, SIZE, OR COLOR.

FOR CLOTHING, NAMELY, SHIRTS, T-SHIRTS, WOVEN SHIRTS, KNIT TOPS, TANK TOPS, SWEATSHIRTS, SWEATERS (U.S. CLS. 22 AND 39).

FIRST USE 1-1-2011; IN COMMERCE 1-1-2011.

CLASS 25—(Continued).

4,119,419. PACIFIC SUNWEAR OF CALIFORNIA, INC., ANAHEIM, CA. SN 85-202,981. PUB. 5-10-2011, FILED 12-21-2010.



THE MARK CONSISTS OF A DESIGN OF 3 TEAR DROP SHAPES, WITH 2 TEAR DROPS ON TOP OF THE THIRD IN AN OVERALL TRIANGULAR CONFIGURATION.

FOR CLOTHING, NAMELY, SHIRTS, T-SHIRTS, WOVEN SHIRTS, FLANNEL SHIRTS, KNIT TOPS, TANK TOPS, DRESSES, SKIRTS, SWEATSHIRTS, JACKETS, SWEATERS, SWIM SUITS, SWIM WEAR, SCARVES, SHAWLS, BELTS, GLOVES, MITTENS, SOCKS; FOOTWEAR, NAMELY, CASUAL FOOTWEAR, SHOES, SANDALS; SLIPPERS, BOOTS; HEADGEAR, NAMELY, HATS, CAPS, VISORS, BEANIES AND HEAD BANDS (U.S. CLS. 22 AND 39).

FIRST USE 1-1-2011; IN COMMERCE 1-1-2011.

4,119,433. EID, LLC., BEND, OR. SN 85-207,514. PUB. 5-3-2011, FILED 12-29-2010.

every 1 deserves

THE MARK CONSISTS OF STANDARD CHARACTERS WITHOUT CLAIM TO ANY PARTICULAR FONT, STYLE, SIZE, OR COLOR.

FOR BEACHWEAR; BEANIES; GOLF SHIRTS; HATS; JACKETS; LOUNGEWEAR; SHIRTS; SWEATPANTS; SWEATSHIRTS; T-SHIRTS; TANK TOPS (U.S. CLS. 22 AND 39).

FIRST USE 9-8-2011; IN COMMERCE 12-7-2011.

CLASS 25—(Continued).

4,119,445. GUDZAN, RICHARD, BIRMINGHAM, AL. SN 85-210,554. PUB. 5-24-2011, FILED 1-5-2011.

PADDLE OUT

THE MARK CONSISTS OF STANDARD CHARACTERS WITHOUT CLAIM TO ANY PARTICULAR FONT, STYLE, SIZE, OR COLOR.

FOR CLOTHING, NAMELY, SHIRTS, SHORTS, PANTS, HATS AND JACKETS (U.S. CLS. 22 AND 39).

FIRST USE 2-2-2011; IN COMMERCE 1-10-2012.

4,119,462. CHOI, TAE YI, ARCADIA, CA. SN 85-215,148. PUB. 5-17-2011, FILED 1-11-2011.

COWGIRL & DIAMONDS

THE MARK CONSISTS OF STANDARD CHARACTERS WITHOUT CLAIM TO ANY PARTICULAR FONT, STYLE, SIZE, OR COLOR.

FOR A-SHIRTS; LONG-SLEEVED SHIRTS (U.S. CLS. 22 AND 39).

FIRST USE 10-17-2011; IN COMMERCE 10-17-2011.

4,119,490. MOLINA, CARMEN L., DBA SMALL HOME BUSINESS, PALM BEACH GARDENS, FL. SN 85-221,927. PUB. 6-7-2011, FILED 1-20-2011.

STRAP N' GUARD

THE MARK CONSISTS OF STANDARD CHARACTERS WITHOUT CLAIM TO ANY PARTICULAR FONT, STYLE, SIZE, OR COLOR.

NO CLAIM IS MADE TO THE EXCLUSIVE RIGHT TO USE "STRAP", APART FROM THE MARK AS SHOWN.

FOR STRAPS FOR BRAS (U.S. CLS. 22 AND 39).

FIRST USE 9-22-2010; IN COMMERCE 1-8-2012.

CLASS 25—(Continued).

4,119,494. PORTOLANO PRODUCTS, INC., NEW YORK, NY. SN 85-223,041. PUB. 5-31-2011, FILED 1-21-2011.

FALL IN GLOVE

THE MARK CONSISTS OF STANDARD CHARACTERS WITHOUT CLAIM TO ANY PARTICULAR FONT, STYLE, SIZE, OR COLOR.
FOR GLOVES (U.S. CLS. 22 AND 39).
FIRST USE 2-17-2011; IN COMMERCE 2-17-2011.

4,119,533. GUTIEREZ, MARCO ENRIQUE LEON, LOS ANGELES, CA. SN 85-237,037. PUB. 6-21-2011, FILED 2-8-2011.



THE COLOR(S) HOT PINK IS/ARE CLAIMED AS A FEATURE OF THE MARK.
THE MARK CONSISTS OF THE STYLIZED HOT PINK WORD "MIREL".
THE WORDING "MIREL" HAS NO MEANING IN A FOREIGN LANGUAGE.
FOR WOMEN'S CLOTHING, NAMELY, SHIRTS, DRESSES, SKIRTS, BLOUSES (U.S. CLS. 22 AND 39).
FIRST USE 1-1-2010; IN COMMERCE 1-1-2010.

4,119,543. BELLISSIMO BRANDS, LLC, TAMPA, FL. SN 85-241,061. PUB. 11-1-2011, FILED 2-13-2011.

HAPPYCRAWLERS

THE MARK CONSISTS OF STANDARD CHARACTERS WITHOUT CLAIM TO ANY PARTICULAR FONT, STYLE, SIZE, OR COLOR.
FOR CLOTHING, NAMELY, LEG WARMERS (U.S. CLS. 22 AND 39).
FIRST USE 5-30-2011; IN COMMERCE 5-30-2011.

CLASS 25—(Continued).

4,119,549. GRANT, STEVEN M., DBA TENKARA PRO, GOODYEAR, AZ. SN 85-244,294. PUB. 6-21-2011, FILED 2-16-2011.

Tenkara PRO

THE MARK CONSISTS OF STANDARD CHARACTERS WITHOUT CLAIM TO ANY PARTICULAR FONT, STYLE, SIZE, OR COLOR.
NO CLAIM IS MADE TO THE EXCLUSIVE RIGHT TO USE "TENKARA", APART FROM THE MARK AS SHOWN. THE ENGLISH TRANSLATION OF "TENKARA" IN THE MARK IS "FROM HEAVEN".
FOR BEANIES; COLLARED SHIRTS; FISHING SHIRTS; HATS; HOODED SWEAT SHIRTS; JACKETS; SHIRTS; SHORT-SLEEVED OR LONG-SLEEVED T-SHIRTS; SWEATERS; WEARABLE GARMENTS AND CLOTHING, NAMELY, SHIRTS (U.S. CLS. 22 AND 39).
FIRST USE 3-2-2011; IN COMMERCE 10-26-2011.

4,119,553. THE SAINT AUGUSTINE LIGHTHOUSE AND MUSEUM, INC., ST. AUGUSTINE, FL. SN 85-245,370. PUB. 6-14-2011, FILED 2-17-2011.

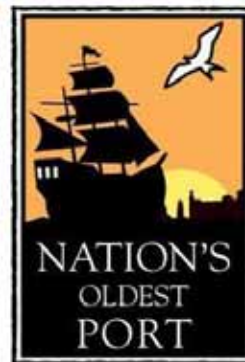

THE COLOR(S) BLACK, WHITE, ORANGE AND YELLOW IS/ARE CLAIMED AS A FEATURE OF THE MARK.
THE MARK CONSISTS OF A SILHOUETTE OF A HISTORICAL SHIP APPEARING IN BLACK AND WHITE SAILING TOWARDS A FORT APPEARING IN THE COLOR BLACK, WITH A RISING SUN APPEARING IN THE COLOR YELLOW IN THE BACKGROUND, AND TO THE RIGHT APPEARS A SILHOUETTE OF A FLYING BIRD IN WHITE OUTLINED IN BLACK, AND BELOW THE HISTORICAL SHIP APPEARS THE WORDING "NATION'S OLDEST PORT" IN WHITE AGAINST A BLACK BACKGROUND, ALL APPEARING AGAINST AN ORANGE BACKGROUND AND CONTAINED WITHIN A DOUBLE-SIDED BLACK AND WHITE RECTANGULAR CARRIER.
FOR T-SHIRTS (U.S. CLS. 22 AND 39).
FIRST USE 1-4-2012; IN COMMERCE 1-4-2012.

CLASS 25—(Continued).

4,119,556. BLANK GENERATION, LLC, SAN DIEGO, CA. SN 85-248,780. PUB. 6-7-2011, FILED 2-22-2011.

TICKLE MONSTER

THE MARK CONSISTS OF STANDARD CHARACTERS WITHOUT CLAIM TO ANY PARTICULAR FONT, STYLE, SIZE, OR COLOR.

FOR APPAREL, NAMELY, T-SHIRTS, SHIRTS, SHORTS, PANTS, SWEATSHIRTS, SWEATPANTS, JACKETS, HATS, SHOES, UNDERWEAR, SOCKS, AND BATHING SUITS (U.S. CLS. 22 AND 39).

FIRST USE 1-10-2012; IN COMMERCE 1-10-2012.

4,119,573. SUTTON DAVID, CHELTENHAM, UNITED KINGDOM. SN 85-257,727. PUB. 8-16-2011, FILED 3-4-2011.

Oily Rag clothing

THE MARK CONSISTS OF STANDARD CHARACTERS WITHOUT CLAIM TO ANY PARTICULAR FONT, STYLE, SIZE, OR COLOR.

NO CLAIM IS MADE TO THE EXCLUSIVE RIGHT TO USE "CLOTHING", APART FROM THE MARK AS SHOWN.

FOR ATHLETIC APPAREL, NAMELY, SHIRTS, PANTS, JACKETS, FOOTWEAR, HATS AND CAPS, ATHLETIC UNIFORMS; SWEAT SHIRTS; T-SHIRTS (U.S. CLS. 22 AND 39).

FIRST USE 6-10-2011; IN COMMERCE 6-10-2011.

4,119,574. CROSBY, MIKE T., VISTA, CA. SN 85-258,229. PUB. 7-26-2011, FILED S.R. 3-4-2011; AM. P.R. 6-15-2011.

SUXION

THE MARK CONSISTS OF STANDARD CHARACTERS WITHOUT CLAIM TO ANY PARTICULAR FONT, STYLE, SIZE, OR COLOR.

FOR ATHLETIC APPAREL, NAMELY, SHIRTS, PANTS, JACKETS, FOOTWEAR, HATS AND CAPS, ATHLETIC UNIFORMS (U.S. CLS. 22 AND 39).

FIRST USE 9-2-2011; IN COMMERCE 10-1-2011.

CLASS 25—(Continued).

4,119,599. SMITH, TYRONE JR, HEPHZIBAH, GA. SN 85-271,522. PUB. 8-30-2011, FILED 3-19-2011.



THE MARK CONSISTS OF THE DESIGN OF A SKULL WITH LONG HAIR WEARING A GRADUATION HAT, THE DEPICTION OF TWO CROSSED SCEPTERS WITH STONES ON THE TOP OF THEM, AND THE STYLIZED WORDING "PIMP SKOOL" BELOW.

FOR BLAZERS; HATS; HOODED SWEAT SHIRTS; JACKETS; SHOES; SWEAT SHIRTS; T-SHIRTS (U.S. CLS. 22 AND 39).

FIRST USE 1-1-2012; IN COMMERCE 1-1-2012.

4,119,600. BRIGHTBILL, MICHAEL, G, WESTLAKE VILLAGE, CA. SN 85-271,626. PUB. 8-2-2011, FILED 3-20-2011.

Beaten and Bangen

THE MARK CONSISTS OF STANDARD CHARACTERS WITHOUT CLAIM TO ANY PARTICULAR FONT, STYLE, SIZE, OR COLOR.

FOR BASEBALL CAPS AND HATS; SHORT-SLEEVED OR LONG-SLEEVED T-SHIRTS; T-SHIRTS; T-SHIRTS FOR RACING FANS (U.S. CLS. 22 AND 39).

FIRST USE 3-17-2011; IN COMMERCE 10-1-2011.

CLASS 25—(Continued).

4,119,608. ZIFENG WANG, ALHAMBRA, CA. SN 85-276,149.
PUB. 8-9-2011, FILED 3-24-2011.

FOND

THE MARK CONSISTS OF STANDARD CHARACTERS WITHOUT CLAIM TO ANY PARTICULAR FONT, STYLE, SIZE, OR COLOR.

FOR BLAZERS; BLOUSES; BOOTS; BUTTON DOWN SHIRTS; COATS; DENIMS; DRESSES; HEELS; JACKETS; KNIT SHIRTS; KNIT TOPS; PANTS; PULLOVERS; SCARVES; SHIRTS; SHOES; SHORTS; SKIRTS; SLIPPERS; SWEATERS; T-SHIRTS; TANK TOPS (U.S. CLS. 22 AND 39).

FIRST USE 9-15-2011; IN COMMERCE 9-15-2011.

4,119,627. GODSON, REBECCA, CARLSBAD, CA. SN 85-291,521. PUB. 8-30-2011, FILED 4-11-2011.

Rootru

THE MARK CONSISTS OF STANDARD CHARACTERS WITHOUT CLAIM TO ANY PARTICULAR FONT, STYLE, SIZE, OR COLOR.

FOR CAPS; HATS; PANTS; SHIRTS; SHOES (U.S. CLS. 22 AND 39).

FIRST USE 11-15-2011; IN COMMERCE 11-15-2011.

4,119,644. TENNIS FIENDS INC., BERKELEY, CA. SN 85-299,361. PUB. 9-20-2011, FILED 4-19-2011.



NO CLAIM IS MADE TO THE EXCLUSIVE RIGHT TO USE "TENNIS", APART FROM THE MARK AS SHOWN.

THE MARK CONSISTS OF AN IMAGE OF A WALKING, PRIMITIVE HUMAN-LIKE CREATURE HOLDING A TENNIS RACKET APPEARING ABOVE THE TERMS "TENNIS FIENDS".

FOR SHIRTS; SOCKS; SWEATBANDS; SWEATERS; VESTS (U.S. CLS. 22 AND 39).

FIRST USE 9-1-2011; IN COMMERCE 9-1-2011.

CLASS 25—(Continued).

4,119,645. PRODOH, LLC, GREENVILLE, SC. SN 85-299,541.
PUB. 9-6-2011, FILED 4-20-2011.

PRODOH

THE MARK CONSISTS OF STANDARD CHARACTERS WITHOUT CLAIM TO ANY PARTICULAR FONT, STYLE, SIZE, OR COLOR.

FOR INFANT WEAR; KNIT SHIRTS; LONG-SLEEVED SHIRTS; SHIRTS; SHIRTS FOR INFANTS, BABIES, TODDLERS AND CHILDREN (U.S. CLS. 22 AND 39).

FIRST USE 7-28-2011; IN COMMERCE 7-28-2011.

4,119,646. PRODOH, LLC, GREENVILLE, SC. SN 85-299,543.
PUB. 9-6-2011, FILED 4-20-2011.

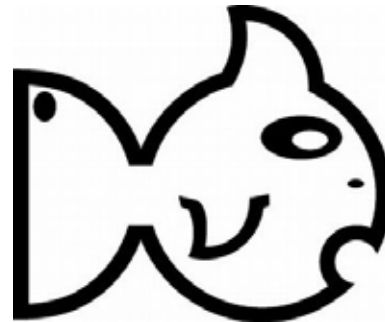

THE MARK CONSISTS OF A FISH DESIGN. FOR INFANT WEAR; SHIRTS; SHIRTS FOR INFANTS, BABIES, TODDLERS AND CHILDREN (U.S. CLS. 22 AND 39).

FIRST USE 7-28-2011; IN COMMERCE 7-28-2011.

4,119,659. THE CIRCLE GROUP INC., LOS ANGELES, CA. SN 85-308,233. PUB. 10-4-2011, FILED 4-29-2011.

DTE IN CALIFORNIA

THE MARK CONSISTS OF STANDARD CHARACTERS WITHOUT CLAIM TO ANY PARTICULAR FONT, STYLE, SIZE, OR COLOR.

CLASS 25—(Continued).

NO CLAIM IS MADE TO THE EXCLUSIVE RIGHT TO USE "CALIFORNIA", APART FROM THE MARK AS SHOWN.

FOR CLOTHING ITEMS, NAMELY, WIND RESISTANT JACKETS, SWEATERS, SHORTS, SHIRTS, SWEATSHIRTS, HATS, VISORS, T-SHIRTS, SWEAT PANTS, JERSEYS, SHORTS, PANTS, TANK TOPS, CAPS, JACKETS, MITTENS, SCARVES, JEANS, BANDANAS, HEADBANDS, WRISTBANDS (U.S. CLS. 22 AND 39).

FIRST USE 12-17-2009; IN COMMERCE 4-1-2010.

4,119,663. JEFFREY BISCHOFF, LEHI, UT. SN 85-309,625. PUB. 9-20-2011, FILED 5-2-2011.

MASSOX

THE MARK CONSISTS OF STANDARD CHARACTERS WITHOUT CLAIM TO ANY PARTICULAR FONT, STYLE, SIZE, OR COLOR.

FOR SOCKS (U.S. CLS. 22 AND 39).

FIRST USE 11-18-2011; IN COMMERCE 12-12-2011.

4,119,675. HAFABROWNDISIGNS, VACAVILLE, CA. SN 85-319,870. PUB. 11-1-2011, FILED 5-12-2011.

hafabrown

THE MARK CONSISTS OF STANDARD CHARACTERS WITHOUT CLAIM TO ANY PARTICULAR FONT, STYLE, SIZE, OR COLOR.

THE ENGLISH TRANSLATION OF THE WORD "HAFA" IN THE MARK IS THE GREETING "HELLO" AND "WHAT'S UP".

FOR T-SHIRTS (U.S. CLS. 22 AND 39).

FIRST USE 7-1-2011; IN COMMERCE 7-1-2011.

4,119,676. HAFABROWNDISIGNS, VACAVILLE, CA. SN 85-319,874. PUB. 11-1-2011, FILED 5-12-2011.

hafagirl

THE MARK CONSISTS OF STANDARD CHARACTERS WITHOUT CLAIM TO ANY PARTICULAR FONT, STYLE, SIZE, OR COLOR.

CLASS 25—(Continued).

THE ENGLISH TRANSLATION OF THE WORD "HAFA" IN THE MARK IS THE GREETING "HELLO" AND "WHAT'S UP".

FOR T-SHIRTS (U.S. CLS. 22 AND 39).

FIRST USE 7-1-2011; IN COMMERCE 7-1-2011.

4,119,688. ECOCLEAN CORPORATION, DBA NAEL COCE, RANDALLSTOWN, MD. SN 85-326,924. PUB. 10-25-2011, FILED 5-22-2011.



The logo for Nael Coce Collection features the word "Nael" in a green, cursive font, followed by "Coce" in a black, cursive font, and "Collection" in a smaller, black, sans-serif font below "Coce".

THE COLOR(S) GREEN AND BLACK IS/ARE CLAIMED AS A FEATURE OF THE MARK.

THE MARK CONSISTS OF THE TEXT "NAEL COCE COLLECTION". "NAEL" IS GREEN WITH A CAPITALIZED "N" AND LOWERCASE "AEL". THE "C" IN "COCE" AND "COLLECTION" IS CAPITALIZED AND GREEN. THE SINGLE "C" IS SHARED TO SPELL BOTH WORDS. THE "OCE" IN "COCE" AND "OLLECTION" IN "COLLECTION" ARE LOWERCASE AND BLACK.

FOR FOOTWEAR (U.S. CLS. 22 AND 39).

FIRST USE 5-15-2011; IN COMMERCE 6-3-2011.

4,119,696. TCL INTERNATIONAL BUSINESS LLC, EDISON, NJ. SN 85-339,297. PUB. 10-25-2011, FILED 6-6-2011.



The logo for V-DELIGHT features the word "V-DELIGHT" in a highly stylized, cursive font. The "V" is large and prominent, followed by "DELIGHT" in a similar but smaller script.

THE MARK CONSISTS OF THE STYLIZED TEXT "V-DELIGHT".

FOR BRASSIERES; LINGERIE (U.S. CLS. 22 AND 39).

FIRST USE 12-13-2010; IN COMMERCE 10-1-2011.

4,119,713. HAFABROWNDISIGNS, VACAVILLE, CA. SN 85-356,297. PUB. 10-25-2011, FILED 6-25-2011.

hafabrowndesigns

THE MARK CONSISTS OF STANDARD CHARACTERS WITHOUT CLAIM TO ANY PARTICULAR FONT, STYLE, SIZE, OR COLOR.

CLASS 25—(Continued).

THE ENGLISH TRANSLATION OF THE WORD "HAFA" IN THE MARK IS THE GREETING "HELLO" AND "WHAT'S UP".

FOR ATHLETIC APPAREL, NAMELY, SHIRTS, PANTS, JACKETS, FOOTWEAR, HATS AND CAPS, ATHLETIC UNIFORMS (U.S. CLS. 22 AND 39).

FIRST USE 7-1-2011; IN COMMERCE 7-1-2011.

4,119,714. HAFABROWNDDESIGNS, VACAVILLE, CA. SN 85-356,301. PUB. 10-25-2011, FILED 6-25-2011.

hafagirlsdesigns

THE MARK CONSISTS OF STANDARD CHARACTERS WITHOUT CLAIM TO ANY PARTICULAR FONT, STYLE, SIZE, OR COLOR.

THE ENGLISH TRANSLATION OF THE WORD "HAFA" IN THE MARK IS THE GREETING "HELLO" AND "WHAT'S UP".

FOR ATHLETIC APPAREL, NAMELY, SHIRTS, PANTS, JACKETS, FOOTWEAR, HATS AND CAPS, ATHLETIC UNIFORMS (U.S. CLS. 22 AND 39).

FIRST USE 7-1-2011; IN COMMERCE 7-1-2011.

4,119,716. STUDIO IP HOLDINGS LLC, WILMINGTON, DE. SN 85-372,158. PUB. 11-1-2011, FILED 7-15-2011.

ROCAWEAR

THE MARK CONSISTS OF STANDARD CHARACTERS WITHOUT CLAIM TO ANY PARTICULAR FONT, STYLE, SIZE, OR COLOR.

OWNER OF U.S. REG. NOS. 2,434,124, 3,007,571, AND OTHERS.

FOR LAYETTES; BIBS NOT OF PAPER; INFANT CAPS (U.S. CLS. 22 AND 39).

FIRST USE 12-31-2001; IN COMMERCE 12-31-2001.

CLASS 25—(Continued).

4,119,729. MICHAEL IAN GOLF LLC, CHICAGO, IL. SN 85-976,258. PUB. 4-19-2011, FILED 10-1-2010.



THE MARK CONSISTS OF A GOLF TEE WEARING A HAT AND SWINGING A GOLF CLUB.

FOR SHIRTS (U.S. CLS. 22 AND 39).

FIRST USE 11-1-2011; IN COMMERCE 11-1-2011.

CLASS 26—FANCY GOODS

4,118,770. 24/7 HAIR, GREAT NECK, NY. SN 76-705,865. PUB. 6-28-2011, FILED 1-3-2011.



NO CLAIM IS MADE TO THE EXCLUSIVE RIGHT TO USE "HAIR", APART FROM THE MARK AS SHOWN.

THE MARK CONSISTS OF THE NUMBERS AND WORDING "24/7 HAIR" AND DESIGN. THE NUMBERS AND WORDING "24/7 HAIR" APPEAR TO THE RIGHT OF A GLOBE. A LINE CURVES UNDER BASE NUMBERS AND WORDING "24/7 HAIR" AND THE BASE OF THE GLOBE IS SUPERIMPOSED ON THE CURVED LINE.

FOR HAIR EXTENSIONS (U.S. CLS. 37, 39, 40, 42 AND 50).

FIRST USE 8-25-2011; IN COMMERCE 8-25-2011.

CLASS 26—(Continued).

4,118,847. WASHINGTON TEAM TENNIS LLC, WASHINGTON, DC. SN 77-494,717. PUB. 10-28-2008, FILED 6-9-2008.

WASHINGTON KASTLES

THE MARK CONSISTS OF STANDARD CHARACTERS WITHOUT CLAIM TO ANY PARTICULAR FONT, STYLE, SIZE, OR COLOR.

NO CLAIM IS MADE TO THE EXCLUSIVE RIGHT TO USE "WASHINGTON", APART FROM THE MARK AS SHOWN.

FOR NOVELTY BUTTONS (U.S. CLS. 37, 39, 40, 42 AND 50).

FIRST USE 4-30-2010; IN COMMERCE 4-30-2010.

4,118,849. WASHINGTON TEAM TENNIS LLC, WASHINGTON, DC. SN 77-494,753. PUB. 11-4-2008, FILED 6-9-2008.



THE MARK CONSISTS OF AN IMAGE OF A KNIGHT WEARING A SHIELD WITH THREE STARS ABOVE A CASTLE, AND A TENNIS RACKET AND TENNIS BALL LOCATED ON EACH SIDE OF THE SHIELD.

FOR NOVELTY BUTTONS (U.S. CLS. 37, 39, 40, 42 AND 50).

FIRST USE 4-30-2010; IN COMMERCE 4-30-2010.

CLASS 27—FLOOR COVERINGS

CLASS 27—(Continued).

4,118,836. STANTON CARPET CORPORATION, SYOSSET, NY. SN 77-476,214. PUB. 10-21-2008, FILED 5-16-2008.

STAINSAFE

THE MARK CONSISTS OF STANDARD CHARACTERS WITHOUT CLAIM TO ANY PARTICULAR FONT, STYLE, SIZE, OR COLOR.

FOR CARPETS, RUGS AND RUNNERS (U.S. CLS. 19, 20, 37, 42 AND 50).

FIRST USE 1-20-2012; IN COMMERCE 1-20-2012.

4,118,898. M7 CORPORATION, DBA METROGRASS, VERBANK, NY. SN 77-665,796. PUB. 6-2-2009, FILED 2-8-2009.

MetroGrass

THE MARK CONSISTS OF STANDARD CHARACTERS WITHOUT CLAIM TO ANY PARTICULAR FONT, STYLE, SIZE, OR COLOR.

NO CLAIM IS MADE TO THE EXCLUSIVE RIGHT TO USE "GRASS", APART FROM THE MARK AS SHOWN.

FOR ARTIFICIAL TURF (U.S. CLS. 19, 20, 37, 42 AND 50).

FIRST USE 8-1-2009; IN COMMERCE 8-1-2009.

4,119,388. BEAULIEU GROUP, LLC, DALTON, GA. SN 85-198,135. PUB. 4-26-2011, FILED 12-15-2010.

**BLISS BY BEAULIEU
HEALTHYTOUCH**

THE MARK CONSISTS OF STANDARD CHARACTERS WITHOUT CLAIM TO ANY PARTICULAR FONT, STYLE, SIZE, OR COLOR.

OWNER OF U.S. REG. NOS. 3,747,306, 3,811,346, AND OTHERS.

THE ENGLISH TRANSLATION OF "BEAULIEU" IN THE MARK IS "BEAUTIFUL PLACE".

FOR CARPETING (U.S. CLS. 19, 20, 37, 42 AND 50).

FIRST USE 5-24-2011; IN COMMERCE 5-24-2011.

CLASS 28—TOYS AND SPORTING GOODS

CLASS 28—(Continued).

4,118,768. JAY AT PLAY INTERNATIONAL HONG KONG LIMITED, HONG KONG, CHINA. SN 76-705,468. PUB. 4-26-2011, FILED 11-24-2010.

KOO KOO KENNEL

THE MARK CONSISTS OF STANDARD CHARACTERS WITHOUT CLAIM TO ANY PARTICULAR FONT, STYLE, SIZE, OR COLOR.

NO CLAIM IS MADE TO THE EXCLUSIVE RIGHT TO USE "KENNEL", APART FROM THE MARK AS SHOWN.

FOR PLUSH TOY ANIMALS AND STUFFED TOY FIGURES; STUFFED TOY ANIMALS (U.S. CLS. 22, 23, 38 AND 50).

FIRST USE 9-23-2011; IN COMMERCE 9-23-2011.

4,118,874. FLYING FROG PRODUCTIONS, LLC, LYNNWOOD, WA. SN 77-587,790. PUB. 2-24-2009, FILED 10-7-2008.

Fortune & Glory

THE MARK CONSISTS OF STANDARD CHARACTERS WITHOUT CLAIM TO ANY PARTICULAR FONT, STYLE, SIZE, OR COLOR.

FOR BOARD GAMES; EQUIPMENT SOLD AS A UNIT FOR PLAYING BOARD GAMES (U.S. CLS. 22, 23, 38 AND 50).

FIRST USE 8-0-2011; IN COMMERCE 8-0-2011.

4,118,884. NALLEY, MARK, MURRIETA, CA. SN 77-636,023. PUB. 4-28-2009, FILED 12-18-2008.

FLEXBELL

THE MARK CONSISTS OF STANDARD CHARACTERS WITHOUT CLAIM TO ANY PARTICULAR FONT, STYLE, SIZE, OR COLOR.

OWNER OF U.S. REG. NOS. 1,723,968 AND 2,260,595.

FOR DUMBBELLS FOR USE IN THE FIELD OF PHYSICAL FITNESS (U.S. CLS. 22, 23, 38 AND 50).

FIRST USE 11-17-2011; IN COMMERCE 11-17-2011.

CLASS 28—(Continued).

4,118,889. LANDSCAPE STRUCTURES, INC., DELANO, MN. SN 77-643,798. PUB. 4-14-2009, FILED 1-6-2009.

BETTER PLAYGROUNDS. BETTER WORLD.

THE MARK CONSISTS OF STANDARD CHARACTERS WITHOUT CLAIM TO ANY PARTICULAR FONT, STYLE, SIZE, OR COLOR.

NO CLAIM IS MADE TO THE EXCLUSIVE RIGHT TO USE "PLAYGROUNDS", APART FROM THE MARK AS SHOWN.

FOR PLAYGROUND EQUIPMENT, NAMELY, SLIDES, LADDERS, BRIDGES, CLIMBING UNITS, RAMPS AND WALKWAYS, DECKS, PROTECTIVE BARRIERS, END BARS, TUNNELS, PLATFORM BARS, BENCHES, NON-LUMINOUS AND NON-MECHANICAL INSTRUCTION SIGNS, POSTS, BEAMS, SOLD IN DIFFERENT COMBINATIONS AS A UNIT (U.S. CLS. 22, 23, 38 AND 50).

FIRST USE 4-1-2011; IN COMMERCE 4-1-2011.

4,118,943. BOTHWELL, BRETT, DBA BOLT SPORTS LLC, NEW YORK, NY. SN 77-828,996. PUB. 2-16-2010, FILED 9-17-2009.

ZIPSTRIP

THE MARK CONSISTS OF STANDARD CHARACTERS WITHOUT CLAIM TO ANY PARTICULAR FONT, STYLE, SIZE, OR COLOR.

FOR RACKET CASES; RACKETS; RACKETS FOR TENNIS (U.S. CLS. 22, 23, 38 AND 50).

FIRST USE 1-1-2010; IN COMMERCE 7-5-2011.

4,118,995. LIFESTYLE BRANDS CORPORATION, ENGLEWOOD, CO. SN 77-910,695. PUB. 6-8-2010, FILED 1-13-2010.

PosiCam

THE MARK CONSISTS OF STANDARD CHARACTERS WITHOUT CLAIM TO ANY PARTICULAR FONT, STYLE, SIZE, OR COLOR.

FOR SNOWBOARD DECKS; SNOWBOARDS (U.S. CLS. 22, 23, 38 AND 50).

FIRST USE 11-1-2009; IN COMMERCE 9-1-2010.

CLASS 28—(Continued).

4,118,996. LIFESTYLE BRANDS CORPORATION, ENGLEWOOD, CO. SN 77-910,707. PUB. 6-8-2010, FILED 1-13-2010.



THE MARK CONSISTS OF THE WORDS "POSI" AND "CAM", SEPARATED BY A PLUS SIGN.
FOR SNOWBOARD DECKS; SNOWBOARDS (U.S. CLS. 22, 23, 38 AND 50).
FIRST USE 11-1-2009; IN COMMERCE 9-1-2010.

4,118,997. LIFESTYLE BRANDS CORPORATION, ENGLEWOOD, CO. SN 77-910,761. PUB. 6-8-2010, FILED 1-13-2010.

AntiCam

THE MARK CONSISTS OF STANDARD CHARACTERS WITHOUT CLAIM TO ANY PARTICULAR FONT, STYLE, SIZE, OR COLOR.
FOR SNOWBOARD DECKS; SNOWBOARDS (U.S. CLS. 22, 23, 38 AND 50).
FIRST USE 11-1-2009; IN COMMERCE 9-1-2010.

4,118,998. LIFESTYLE BRANDS CORPORATION, ENGLEWOOD, CO. SN 77-910,775. PUB. 6-8-2010, FILED 1-13-2010.



THE MARK CONSISTS OF A STYLIZED LETTER "A" ON TOP OF A CIRCLE, WITH THE WORDS "ANTICAM" TO THE RIGHT.
FOR SNOWBOARD DECKS; SNOWBOARDS (U.S. CLS. 22, 23, 38 AND 50).
FIRST USE 11-1-2009; IN COMMERCE 9-1-2010.

CLASS 28—(Continued).

4,119,013. LIFESTYLE BRANDS CORPORATION, ENGLEWOOD, CO. SN 77-924,703. PUB. 6-8-2010, FILED 2-1-2010.



THE MARK CONSISTS OF A CYLINDER-SHAPED, UPWARD CURVING DESIGN BEARING THE WORDS "MAC CAM" WITH A LIQUID PUDDLE DESIGN IMMEDIATELY UNDERNEATH.
FOR SNOWBOARD DECKS; SNOWBOARDS (U.S. CLS. 22, 23, 38 AND 50).
FIRST USE 11-1-2009; IN COMMERCE 9-1-2010.

4,119,047. CRAIG W. NELSON REVOCABLE TRUST, WESTCHESTERFIELD, NH. SN 77-968,213. PUB. 8-3-2010, FILED 3-25-2010.

SKEEPER

THE MARK CONSISTS OF STANDARD CHARACTERS WITHOUT CLAIM TO ANY PARTICULAR FONT, STYLE, SIZE, OR COLOR.
FOR STORAGE RACKS FOR SKI AND SPORTS EQUIPMENT (U.S. CLS. 22, 23, 38 AND 50).
FIRST USE 11-23-2011; IN COMMERCE 11-23-2011.

4,119,159. PATCH PRODUCTS, INC., BELOIT, WI. SN 85-066,999. PUB. 11-16-2010, FILED 6-19-2010.

LOVE IT! HATE IT!

THE MARK CONSISTS OF STANDARD CHARACTERS WITHOUT CLAIM TO ANY PARTICULAR FONT, STYLE, SIZE, OR COLOR.
FOR BOARD GAMES; PARLOR GAMES (U.S. CLS. 22, 23, 38 AND 50).
FIRST USE 2-1-2011; IN COMMERCE 2-1-2011.

CLASS 28—(Continued).

4,119,183. CONWAY GOLF, LLC, FREEVILLE, NY. SN 85-077,069. PUB. 6-7-2011, FILED 7-2-2010.

Range Caddy

THE MARK CONSISTS OF STANDARD CHARACTERS WITHOUT CLAIM TO ANY PARTICULAR FONT, STYLE, SIZE, OR COLOR.

FOR GOLF SWING TRAINING AIDS, NAMELY, PRACTICE TEE AIDS FOR PROVIDING INFORMATION ABOUT PLAYER SETUP AND BALL POSITION (U.S. CLS. 22, 23, 38 AND 50).

FIRST USE 12-31-2010; IN COMMERCE 4-20-2011.

4,119,209. PATCH PRODUCTS, INC., BELOIT, WI. SN 85-091,494. PUB. 11-16-2010, FILED 7-23-2010.

TALES TO PLAY

THE MARK CONSISTS OF STANDARD CHARACTERS WITHOUT CLAIM TO ANY PARTICULAR FONT, STYLE, SIZE, OR COLOR.

FOR BOARD GAMES; CARD GAMES; EDUCATIONAL CARD GAMES; PARLOR GAMES; PARTY GAMES (U.S. CLS. 22, 23, 38 AND 50).

FIRST USE 7-11-2011; IN COMMERCE 7-11-2011.

4,119,212. WUXI JUNZHENG TRADING CO., LTD., JIANGSU PROVINCE, CHINA. SN 85-096,464. PUB. 5-10-2011, FILED 7-30-2010.



Octopus Paul

章魚保羅

THE MARK CONSISTS OF A CIRCLE CONTAINING AN OCTOPUS WEARING A CROWN. BELOW THE DESIGN OF THE OCTOPUS IS THE WORDING "OCTOPUS PAUL" AND BELOW THIS ARE FOUR CHINESE CHARACTERS THAT TRANSLITERATE INTO "ZHANG YU BAO LUO".

THE ENGLISH TRANSLATION OF THE CHINESE CHARACTERS IS "OCTOPUS PAUL".

CLASS 28—(Continued).

THE NON-LATIN CHARACTERS IN THE MARK TRANSLITERATE TO "ZHANG YU BAO LUO".

FOR ARCADE GAMES; ARCHERY IMPLEMENTS; BALLS FOR GAMES; BASEBALL GLOVES; BOARD GAMES; BODY-TRAINING APPARATUS; CHRISTMAS TREE ORNAMENTS; EXERCISE MACHINES; FISHING TACKLE; GOLF GLOVES; TOY FIGURES; TOY VEHICLES; WORK-OUT GLOVES (U.S. CLS. 22, 23, 38 AND 50).

FIRST USE 7-30-2010; IN COMMERCE 7-30-2010.

4,119,253. CJ PRODUCTS, LLC, OCEANSIDE, CA. SN 85-123,435. PUB. 3-15-2011, FILED 9-5-2010.

PILLOW PETS DREAMLAND

THE MARK CONSISTS OF STANDARD CHARACTERS WITHOUT CLAIM TO ANY PARTICULAR FONT, STYLE, SIZE, OR COLOR.

FOR BOARD GAMES; PLAYING CARDS AND CARD GAMES; PRINTED POSITIONABLE TOYS FOR USE IN CHILDREN'S BOARD GAMES (U.S. CLS. 22, 23, 38 AND 50).

FIRST USE 11-1-2010; IN COMMERCE 11-1-2010.

4,119,317. ARIZONA MANUFACTURING & EMBROIDERY, INC., TEMPE, AZ. SN 85-171,959. PUB. 3-29-2011, FILED 11-8-2010.

FOR THOSE WHO KNOW GOLF

THE MARK CONSISTS OF STANDARD CHARACTERS WITHOUT CLAIM TO ANY PARTICULAR FONT, STYLE, SIZE, OR COLOR.

FOR GOLF ACCESSORIES, NAMELY, GOLF CLUB COVERS, GOLF CLUB HEAD COVERS, GOLF PUTTER COVERS (U.S. CLS. 22, 23, 38 AND 50).

FIRST USE 1-29-2010; IN COMMERCE 3-28-2011.

4,119,322. THE CHENILLE KRAFT COMPANY, GURNEE, IL. SN 85-175,930. PUB. 5-3-2011, FILED 11-12-2010.

SQUISHY FOAM

THE MARK CONSISTS OF STANDARD CHARACTERS WITHOUT CLAIM TO ANY PARTICULAR FONT, STYLE, SIZE, OR COLOR.

CLASS 28—(Continued).

NO CLAIM IS MADE TO THE EXCLUSIVE RIGHT TO USE "FOAM", APART FROM THE MARK AS SHOWN.
FOR SOFT SCULPTURE EDUCATIONAL TOYS; EDUCATIONAL HOBBY CRAFT KIT COMPRISING FOAM SHAPES AND DESIGNS (U.S. CLS. 22, 23, 38 AND 50).
FIRST USE 1-26-2011; IN COMMERCE 1-26-2011.

4,119,391. FOLKMANIS, INC., EMERYVILLE, CA. SN 85-198,302. PUB. 4-26-2011, FILED 12-15-2010.

FOLKMONSTER

THE MARK CONSISTS OF STANDARD CHARACTERS WITHOUT CLAIM TO ANY PARTICULAR FONT, STYLE, SIZE, OR COLOR.
OWNER OF U.S. REG. NO. 1,367,863.
FOR PUPPETS (U.S. CLS. 22, 23, 38 AND 50).
FIRST USE 1-11-2011; IN COMMERCE 1-11-2011.

4,119,397. RED SLATE BRANDS, INC., ROAD TOWN, BR. VIRGIN ISLANDS. SN 85-199,163. PUB. 5-10-2011, FILED 12-16-2010.

SIMPLE STRING

THE MARK CONSISTS OF STANDARD CHARACTERS WITHOUT CLAIM TO ANY PARTICULAR FONT, STYLE, SIZE, OR COLOR.
FOR ARTIFICIAL CHRISTMAS TREES, EXCEPT LIGHT STRING CHRISTMAS TREES (U.S. CLS. 22, 23, 38 AND 50).
FIRST USE 9-27-2011; IN COMMERCE 9-27-2011.

4,119,423. BUZZ BEE TOYS, INC., MT. LAUREL, NJ. SN 85-203,624. PUB. 5-3-2011, FILED 12-22-2010.

TORRENT

THE MARK CONSISTS OF STANDARD CHARACTERS WITHOUT CLAIM TO ANY PARTICULAR FONT, STYLE, SIZE, OR COLOR.
FOR TOY PROJECTILE SHOOTERS AND ACCESSORIES THEREFOR (U.S. CLS. 22, 23, 38 AND 50).
FIRST USE 10-1-2010; IN COMMERCE 5-16-2011.

CLASS 28—(Continued).

4,119,435. LUCKY CRAFT CO., LTD., OYABE-SHI, TOYAMA, JAPAN. SN 85-207,941. PUB. 5-17-2011, FILED 12-30-2010.

LC CRANK

THE MARK CONSISTS OF STANDARD CHARACTERS WITHOUT CLAIM TO ANY PARTICULAR FONT, STYLE, SIZE, OR COLOR.
OWNER OF U.S. REG. NOS. 3,030,751, 3,661,254, AND 3,661,255.
NO CLAIM IS MADE TO THE EXCLUSIVE RIGHT TO USE "CRANK", APART FROM THE MARK AS SHOWN.
FOR FISHING EQUIPMENT, NAMELY, FISHING LURES (U.S. CLS. 22, 23, 38 AND 50).
FIRST USE 1-1-2011; IN COMMERCE 1-1-2011.

4,119,436. LUCKY CRAFT CO., LTD., OYABE-SHI, TOYAMA, JAPAN. SN 85-208,152. PUB. 5-17-2011, FILED 12-30-2010.

KJ PROP

THE MARK CONSISTS OF STANDARD CHARACTERS WITHOUT CLAIM TO ANY PARTICULAR FONT, STYLE, SIZE, OR COLOR.
NO CLAIM IS MADE TO THE EXCLUSIVE RIGHT TO USE "PROP", APART FROM THE MARK AS SHOWN.
FOR FISHING EQUIPMENT, NAMELY, FISHING LURES (U.S. CLS. 22, 23, 38 AND 50).
FIRST USE 1-1-2011; IN COMMERCE 1-1-2011.

4,119,460. SEARS BRANDS, LLC, HOFFMAN ESTATES, IL. SN 85-214,364. PUB. 5-3-2011, FILED 1-10-2011.

GOLDEN ADORNMENTS

THE MARK CONSISTS OF STANDARD CHARACTERS WITHOUT CLAIM TO ANY PARTICULAR FONT, STYLE, SIZE, OR COLOR.

CLASS 28—(Continued).

NO CLAIM IS MADE TO THE EXCLUSIVE RIGHT TO USE "ADORNMENTS", APART FROM THE MARK AS SHOWN.

FOR ARTIFICIAL CHRISTMAS GARLANDS; ARTIFICIAL CHRISTMAS WREATHS; PRE-LIT ARTIFICIAL CHRISTMAS GARLANDS; PRE-LIT ARTIFICIAL CHRISTMAS WREATHS; CHRISTMAS TREE ORNAMENTS; CHRISTMAS TREE ORNAMENTS, NAMELY, TREE TOPPERS; CHRISTMAS TREE DECORATIONS; CHRISTMAS TREE SKIRTS; CHRISTMAS STOCKINGS; TINSEL FOR CHRISTMAS TREES (U.S. CLS. 22, 23, 38 AND 50).

FIRST USE 9-0-2011; IN COMMERCE 9-0-2011.

4,119,515. KAUSEN, LEE, COEUR D' ALENE, ID. AND KAUSEN, JILL, COEUR D' ALENE, ID. SN 85-229,747. PUB. 6-7-2011, FILED 1-31-2011.

WINE-O

THE MARK CONSISTS OF STANDARD CHARACTERS WITHOUT CLAIM TO ANY PARTICULAR FONT, STYLE, SIZE, OR COLOR.

FOR BOARD GAMES (U.S. CLS. 22, 23, 38 AND 50).
FIRST USE 11-11-2011; IN COMMERCE 11-11-2011.

4,119,554. MASSENGILL, MARTHA JO, TERRELL, TX. SN 85-247,484. PUB. 8-23-2011, FILED 2-21-2011.

SPINNER

OWNER OF U.S. REG. NO. 3,931,750.
THE MARK CONSISTS OF THE WORD "SPINNER" WITH A FIGURE REPRESENTATIVE OF A SPINNING MOTION ABOVE THE "I".

FOR EQUIPMENT SOLD AS A UNIT FOR PLAYING A PARLOUR GAME (U.S. CLS. 22, 23, 38 AND 50).
FIRST USE 12-31-2002; IN COMMERCE 12-31-2002.

CLASS 28—(Continued).

4,119,568. THE KONG COMPANY, GOLDEN, CO. SN 85-255,661. PUB. 9-6-2011, FILED 3-2-2011.

KONG SQUEEZZ

THE MARK CONSISTS OF STANDARD CHARACTERS WITHOUT CLAIM TO ANY PARTICULAR FONT, STYLE, SIZE, OR COLOR.

OWNER OF U.S. REG. NOS. 1,443,417, 3,020,593, AND OTHERS.

NO CLAIM IS MADE TO THE EXCLUSIVE RIGHT TO USE "SQUEEZE", APART FROM THE MARK AS SHOWN.
FOR PET TOYS (U.S. CLS. 22, 23, 38 AND 50).
FIRST USE 3-30-2010; IN COMMERCE 3-30-2010.

4,119,579. AYOTTE, FRANCOIS, MONTREAL QC, CANADA. SN 85-259,756. PUB. 7-26-2011, FILED 3-7-2011.

ANARCHY

THE MARK CONSISTS OF STANDARD CHARACTERS WITHOUT CLAIM TO ANY PARTICULAR FONT, STYLE, SIZE, OR COLOR.

FOR LONGBOARDS (U.S. CLS. 22, 23, 38 AND 50).
FIRST USE 9-1-2011; IN COMMERCE 9-1-2011.

4,119,601. CHAPCO PRODUCTS INC, MIDLOTHIAN, TX. SN 85-271,673. PUB. 9-6-2011, FILED 3-20-2011.

Tee it easy

NO CLAIM IS MADE TO THE EXCLUSIVE RIGHT TO USE "TEE", APART FROM THE MARK AS SHOWN.

THE MARK CONSISTS OF THE STYLIZED TEXT "TEE IT EASY" WITH A GOLF BALL ON THE TOP.

FOR GOLFING AID THAT ALLOWS USERS TO CHOOSE ONE OF THREE HEIGHTS FOR TEEING A GOLF BALL (U.S. CLS. 22, 23, 38 AND 50).
FIRST USE 3-1-2011; IN COMMERCE 11-1-2010.

CLASS 28—(Continued).

4,119,661. JIN HONG EU, TAMPA, FL. SN 85-309,361. PUB. 10-25-2011, FILED 5-1-2011.



NO CLAIM IS MADE TO THE EXCLUSIVE RIGHT TO USE "PRO FISHING", APART FROM THE MARK AS SHOWN.

THE MARK CONSISTS OF THE WORDING "HYTAC", WITH THE LETTER "H" INSIDE A DESIGN OF A FISH. THE WORDING "PRO FISHING" IS UNDERNEATH THE LETTERS "TAC" IN SMALLER LETTERS.

FOR SPORTING EQUIPMENT FOR FISHING, NAMELY, RODS, ROD BLANKS, REELS, HOOKS, LINES AND LURES; FISHING ACCESSORIES, NAMELY, TACKLE BOXES AND FISHING TERMINAL (U.S. CLS. 22, 23, 38 AND 50).

FIRST USE 1-1-2008; IN COMMERCE 1-1-2008.

4,119,689. RONALD D. BURNETT, NEWPORT NEWS, VA. SN 85-327,513. PUB. 10-18-2011, FILED 5-23-2011.

Pew Pals

THE MARK CONSISTS OF STANDARD CHARACTERS WITHOUT CLAIM TO ANY PARTICULAR FONT, STYLE, SIZE, OR COLOR.

FOR DOLLS AND DOLL ACCESSORIES, NAMELY, CLOTHING FOR DOLLS, DOLL ROOMS, DOLL BEDS, DOLL HOUSES, TOY FABRICS AND LINENS FOR DOLLS AND STROLLERS FOR DOLLS; STUFFED AND PLUSH TOYS; STUFFED TOY ANIMALS (U.S. CLS. 22, 23, 38 AND 50).

FIRST USE 11-10-2011; IN COMMERCE 11-10-2011.

CLASS 28—(Continued).

4,119,695. PIONEER PET PRODUCTS, LLC, CEDARBURG, WI. SN 85-339,057. PUB. 11-1-2011, FILED 6-6-2011.

NIP NIBBLERS

THE MARK CONSISTS OF STANDARD CHARACTERS WITHOUT CLAIM TO ANY PARTICULAR FONT, STYLE, SIZE, OR COLOR.

FOR TOYS FOR DOMESTIC PETS, NAMELY, PET TOYS CONTAINING CATNIP AND CAT TOYS (U.S. CLS. 22, 23, 38 AND 50).

FIRST USE 12-1-2011; IN COMMERCE 12-1-2011.

CLASS 29—MEATS AND PROCESSED FOODS

4,118,903. PARMALAT CANADA INC., ETOBICOKE, CANADA. SN 77-697,624. PUB. 3-9-2010, FILED 3-24-2009.

ASTRO

THE MARK CONSISTS OF STANDARD CHARACTERS WITHOUT CLAIM TO ANY PARTICULAR FONT, STYLE, SIZE, OR COLOR.

OWNER OF CANADA REG. NO. TMA226502, DATED 3-10-1978, RENEWED AS REG. NO. TMA226502, DATED 3-10-2008, EXPIRES 3-10-2023.

OWNER OF U.S. REG. NO. 2,910,622.

FOR MARGARINE, SOUR CREAM, DAIRY-BASED DIPS AND COTTAGE CHEESE, YOGURT BEVERAGES AND TZATZKI DAIRY-BASED SPREAD (U.S. CL. 46).

FIRST USE 1-27-2009; IN COMMERCE 6-7-2011.

4,119,058. MAYHEW & ASSOCIATES, INC., IRVINE, CA. SN 78-662,141. PUB. 3-14-2006, FILED 6-30-2005.

NUTRI-FARMS

THE MARK CONSISTS OF STANDARD CHARACTERS WITHOUT CLAIM TO ANY PARTICULAR FONT, STYLE, SIZE, OR COLOR.

FOR FROZEN ENTREES CONSISTING PRIMARILY OF MEAT (U.S. CL. 46).

FIRST USE 9-7-2011; IN COMMERCE 9-7-2011.

CLASS 29—(Continued).

4,119,313. OREGON CHERRY GROWERS, INC., SALEM, OR.
SN 85-163,677. PUB. 11-1-2011, FILED 10-28-2010.

CLASS 29—(Continued).

4,119,534. BARRON COUNTY CHEESE LLC, BARRON, WI.
SN 85-237,560. PUB. 6-21-2011, FILED 2-9-2011.

BORDEAUX**Screaming Dutchman**

THE MARK CONSISTS OF STANDARD CHARACTERS
WITHOUT CLAIM TO ANY PARTICULAR FONT, STYLE,
SIZE, OR COLOR.

FOR PROCESSED CHERRIES (U.S. CL. 46).
FIRST USE 5-2-2011; IN COMMERCE 5-3-2011.

THE MARK CONSISTS OF STANDARD CHARACTERS
WITHOUT CLAIM TO ANY PARTICULAR FONT, STYLE,
SIZE, OR COLOR.

FOR BLENDED CHEESE; CHEESE; CHEESE FOOD;
CHEESE SPREADS (U.S. CL. 46).
FIRST USE 3-1-2011; IN COMMERCE 5-1-2011.

4,119,473. CBI INTERNATIONAL, LLC, HIALEAH, FL. SN
85-217,991. PUB. 5-31-2011, FILED 1-14-2011.

4,119,593. LINK SNACKS, INC., MINONG, WI. SN 85-267,673.
PUB. 8-2-2011, FILED 3-15-2011.

CAPITA**A REVOLUTIONARY SNACKING
EXPERIENCE**

THE MARK CONSISTS OF STANDARD CHARACTERS
WITHOUT CLAIM TO ANY PARTICULAR FONT, STYLE,
SIZE, OR COLOR.

FOR CHEESE (U.S. CL. 46).
FIRST USE 3-5-2010; IN COMMERCE 3-5-2010.

THE MARK CONSISTS OF STANDARD CHARACTERS
WITHOUT CLAIM TO ANY PARTICULAR FONT, STYLE,
SIZE, OR COLOR.

FOR MEAT SNACKS (U.S. CL. 46).
FIRST USE 7-15-2011; IN COMMERCE 7-15-2011.

4,119,531. QUESOS LA PARDINA, S.L, VALENCIA, SPAIN.
SN 85-235,842. PUB. 7-5-2011, FILED 2-7-2011.

4,119,681. DIMICELI, ROBIN, COPPEROPOLIS, CA. SN 85-
325,599. PUB. 9-13-2011, FILED 5-20-2011.

RIPPED CREAM

THE COLOR(S) BLUE AND RED IS/ARE CLAIMED AS A
FEATURE OF THE MARK.

THE MARK CONSISTS OF THE WORD "LA PARDINA"
IN THE COLOR BLUE DIAGONALLY LOCATED ABOVE A
RED LINE.

THE WORDING "LA PARDINA" HAS NO MEANING IN
A FOREIGN LANGUAGE.

FOR CHEESE (U.S. CL. 46).
FIRST USE 1-1-2000; IN COMMERCE 9-1-2011.

THE MARK CONSISTS OF STANDARD CHARACTERS
WITHOUT CLAIM TO ANY PARTICULAR FONT, STYLE,
SIZE, OR COLOR.

NO CLAIM IS MADE TO THE EXCLUSIVE RIGHT TO
USE "CREAM", APART FROM THE MARK AS SHOWN.

FOR COFFEE CREAMER; CREAMERS FOR BEV-
ERAGES; COFFEE CREAMER FEATURING PROTEIN
(U.S. CL. 46).

FIRST USE 11-11-2011; IN COMMERCE 11-11-2011.

CLASS 29—(Continued).

4,119,720. FRESH EXPRESS INCORPORATED, SALINAS, CA. SN 85-975,677. PUB. 3-8-2011, FILED 11-4-2010.

FRESH RINSE

THE MARK CONSISTS OF STANDARD CHARACTERS WITHOUT CLAIM TO ANY PARTICULAR FONT, STYLE, SIZE, OR COLOR.

NO CLAIM IS MADE TO THE EXCLUSIVE RIGHT TO USE "FRESH", APART FROM THE MARK AS SHOWN.

FOR PRE-CUT PACKAGED VEGETABLES; PACKAGED GARDEN SALADS, PACKAGED VEGETABLE SALADS AND PACKAGED LETTUCE SALADS (U.S. CL. 46).

FIRST USE 7-29-2011; IN COMMERCE 7-29-2011.

4,119,722. AMERICAN HALAL CO., INC., STAMFORD, CT. SN 85-976,175. PUB. 10-12-2010, FILED 5-13-2010.

SAFFRON ROAD

THE MARK CONSISTS OF STANDARD CHARACTERS WITHOUT CLAIM TO ANY PARTICULAR FONT, STYLE, SIZE, OR COLOR.

FOR FRESH AND FROZEN CHICKEN, FRESH AND FROZEN BEEF, PREPACKAGED DINNERS CONSISTING PRIMARILY OF MEAT, POULTRY, WITH PASTA, RICE AND VEGETABLES; FROZEN OR PREPARED MEALS CONSISTING PRIMARILY OF MEAT, POULTRY, AND VEGETABLES (U.S. CL. 46).

FIRST USE 5-9-2011; IN COMMERCE 5-9-2011.

CLASS 30—STAPLE FOODS

4,118,800. CHESLEY R. HOUSKE, JR., DDS, INC., SANTA BARBARA, CA. SN 77-332,195. PUB. 11-4-2008, FILED 11-16-2007.

ISLAND DENTAL

THE MARK CONSISTS OF STANDARD CHARACTERS WITHOUT CLAIM TO ANY PARTICULAR FONT, STYLE, SIZE, OR COLOR.

NO CLAIM IS MADE TO THE EXCLUSIVE RIGHT TO USE "DENTAL", APART FROM THE MARK AS SHOWN.

FOR CHEWING GUM (U.S. CL. 46).
FIRST USE 1-20-2012; IN COMMERCE 1-20-2012.

CLASS 30—(Continued).

4,118,824. FRATELLI FANTINI S.P.A., 28010 PELLA NO, ITALY. SN 77-441,469. PUB. 4-14-2009, FILED 4-7-2008.

FANTINI

THE MARK CONSISTS OF STANDARD CHARACTERS WITHOUT CLAIM TO ANY PARTICULAR FONT, STYLE, SIZE, OR COLOR.

THE ENGLISH TRANSLATION OF "FANTINI" IS JOCKEYS.

FOR COFFEE, TEA, COCOA, SUGAR, RICE, TAPIOCA, SAGO, ARTIFICIAL COFFEE; FLOUR, PREPARATIONS MADE FROM CEREALS, NAMELY, BREAKFAST CEREALS; BREAD, PASTRY AND CONFECTIONERY, NAMELY, PASTILLES, FONDANTS; ICES; HONEY, TREACLE; YEAST, BAKING-POWDER; SALT, MUSTARD; VINEGAR, SAUCES BEING CONDIMENTS; SPICES; ICE (U.S. CL. 46).

FIRST USE 12-1-2008; IN COMMERCE 12-1-2008.

4,118,866. MPC PROPERTIES, LLC, JACKSON HEIGHTS, NY. SN 77-545,347. PUB. 12-30-2008, FILED 8-12-2008.



THE MARK CONSISTS OF A STICK FIGURE OF A MAN COMPOSED OF THE LETTERS "J" AND "H", WEARING A TOP HAT.

FOR SANDWICHES, NAMELY, BURGERS (U.S. CL. 46).

FIRST USE 11-11-2011; IN COMMERCE 11-11-2011.

CLASS 30—(Continued).

4,118,970. US ROASTERIE, INC., DES MOINES, IA. SN 77-880,435. PUB. 10-26-2010, FILED 11-24-2009.

CAFE PERKS

THE MARK CONSISTS OF STANDARD CHARACTERS WITHOUT CLAIM TO ANY PARTICULAR FONT, STYLE, SIZE, OR COLOR.

NO CLAIM IS MADE TO THE EXCLUSIVE RIGHT TO USE "CAFE", APART FROM THE MARK AS SHOWN.

FOR CAPPUCCINO; COFFEE (U.S. CL. 46).

FIRST USE 10-0-2011; IN COMMERCE 10-0-2011.

4,119,100. ZANLYN LLC, IRVING, TX. SN 85-038,134. PUB. 10-19-2010, FILED 5-13-2010.



THE MARK CONSISTS OF A CURVED BAND WITH THE STYLIZED TEXT "ZANLYN" APPEARING TO THE RIGHT. FOR PREPARED FERMENTED BATTER MIXES FOR IDLI/DOSA (U.S. CL. 46).

FIRST USE 12-14-2010; IN COMMERCE 12-14-2010.

4,119,131. LOUISVILLE'S EPICUREAN MARKETS, LLC, LOUISVILLE, KY. SN 85-053,458. PUB. 11-23-2010, FILED 6-3-2010.



NO CLAIM IS MADE TO THE EXCLUSIVE RIGHT TO USE "DESIGNER BREADS", APART FROM THE MARK AS SHOWN.

CLASS 30—(Continued).

THE MARK CONSISTS OF THE WORDS "BRAD'S DESIGNER BREADS" IN A HIGHLY STYLIZED FONT ENCLOSED WITHIN A DOUBLE-LINED RECTANGLE. DEPICTIONS OF BREAD PRODUCTS, NAMELY, A BUN, BOULE AND BAGUETTE, ARE SUPERIMPOSED OVER THE UPPER PORTION OF THE RECTANGLE. THE WORDING "BAKING A BETTER WORLD..." APPEARS IN A HIGHLY STYLIZED FONT BELOW THE RECTANGLE; THE WORDING "ONE BOULE AT A TIME" APPEARS IN A HIGHLY STYLIZED FONT VERTICALLY AND TO THE RIGHT OF THE RECTANGLE.

FOR BAKERY GOODS; BREAD; COOKIES; BISCOTTI; SCONES; PASTRY (U.S. CL. 46).

FIRST USE 3-0-2011; IN COMMERCE 9-24-2011.

4,119,292. SANTA MONICA CHOCOLATE COMPANY, LLC, SANTA MONICA, CA. SN 85-152,682. PUB. 2-15-2011, FILED 10-14-2010.

Enjoy Irresponsibly.

THE MARK CONSISTS OF STANDARD CHARACTERS WITHOUT CLAIM TO ANY PARTICULAR FONT, STYLE, SIZE, OR COLOR.

FOR CHOCOLATE CANDIES; CHOCOLATE SAUCE; CHOCOLATE TRUFFLES; CONFECTIONERIES, NAMELY, SNACK FOODS, NAMELY, CHOCOLATE; FILLED CHOCOLATE; SNACK FOODS, NAMELY, CHOCOLATE-BASED SNACK FOODS (U.S. CL. 46).

FIRST USE 12-1-2010; IN COMMERCE 12-15-2010.

4,119,381. MANULELE CANE COMPANY, LLC, KUNIA, HI. SN 85-196,834. PUB. 4-26-2011, FILED 12-13-2010.

Hana Aloha

THE MARK CONSISTS OF STANDARD CHARACTERS WITHOUT CLAIM TO ANY PARTICULAR FONT, STYLE, SIZE, OR COLOR.

THE ENGLISH TRANSLATION OF "HANA ALOHA" IN THE MARK IS "LOVE MAGIC".

FOR SYRUP MADE FROM JUICE OF HAWAIIAN GROWN SUGARCANE (U.S. CL. 46).

FIRST USE 12-11-2011; IN COMMERCE 12-11-2011.

CLASS 30—(Continued).

4,119,431. TERRY HARRIS, CORDOVA, TN. SN 85-206,876.
PUB. 5-3-2011, FILED 12-28-2010.

PUNCHING SLEEPY IN THE FACE

THE MARK CONSISTS OF STANDARD CHARACTERS WITHOUT CLAIM TO ANY PARTICULAR FONT, STYLE, SIZE, OR COLOR.

FOR BROWNIES; CAKES (U.S. CL. 46).
FIRST USE 3-0-2011; IN COMMERCE 3-0-2011.

4,119,456. BOWLER, WOSSENE, LAGUNA BEACH, CA. SN 85-214,052. PUB. 5-24-2011, FILED 1-10-2011.

BLACK RAIN

THE MARK CONSISTS OF STANDARD CHARACTERS WITHOUT CLAIM TO ANY PARTICULAR FONT, STYLE, SIZE, OR COLOR.

FOR GROUND COFFEE BEANS (U.S. CL. 46).
FIRST USE 1-7-2012; IN COMMERCE 1-7-2012.

4,119,476. WEAVER POPCORN COMPANY INC, NOBLESVILLE, IN. SN 85-219,171. PUB. 5-17-2011, FILED 1-17-2011.

WEAVER GOLD

THE MARK CONSISTS OF STANDARD CHARACTERS WITHOUT CLAIM TO ANY PARTICULAR FONT, STYLE, SIZE, OR COLOR.

OWNER OF U.S. REG. NOS. 1,690,407, 2,992,289, AND OTHERS.
FOR MICROWAVE POPCORN (U.S. CL. 46).
FIRST USE 3-2-2011; IN COMMERCE 3-2-2011.

CLASS 30—(Continued).

4,119,510. SIMPLEFARE LLC, BEAVERTON, OR. SN 85-228,302. PUB. 5-31-2011, FILED 1-27-2011.

SIMPLEFARE

THE MARK CONSISTS OF STANDARD CHARACTERS WITHOUT CLAIM TO ANY PARTICULAR FONT, STYLE, SIZE, OR COLOR.

FOR FROZEN ENTREES CONSISTING PRIMARILY OF PASTA OR RICE (U.S. CL. 46).
FIRST USE 9-15-2011; IN COMMERCE 9-15-2011.

4,119,514. COOKIE FAIRY SWEETS, INC., BROOKLYN, NY. SN 85-229,360. PUB. 6-28-2011, FILED 1-28-2011.



NO CLAIM IS MADE TO THE EXCLUSIVE RIGHT TO USE "COOKIE" AND "SWEETS", APART FROM THE MARK AS SHOWN.

THE COLOR(S) BROWN, YELLOW, TEAL GREEN, BLACK, WHITE, RED, YELLOW, LIGHT BLUE, LIGHT PINK, HOT PINK, TAN, PURPLE, AND BLUE IS/ARE CLAIMED AS A FEATURE OF THE MARK.

THE MARK CONSISTS OF THE TERMS "COOKIE FAIRY SWEETS" IN STYLIZED LETTERS IN BROWN OUTLINED IN YELLOW INSIDE OF A TEAL GREEN, HALF-SMILING MOON SHAPE. TO THE UPPER RIGHT OF THE WORDS AND MOON-SHAPED DESIGN IS A STYLIZED FAIRY HOLDING A WAND TOPPED BY A STAR-SHAPED SUGAR COOKIE. THE FAIRY HAS LIGHT PINK SKIN WITH BLACK AND WHITE FACIAL FEATURES, BROWN HAIR WITH TAN HIGHLIGHTS, A RED DRESS, YELLOW APRON, LIGHT BLUE WINGS, HOT PINK LIPS AND BROWN BALLET SLIPPER SHOES. THE HANDLE OF THE SUGAR COOKIE WAND IS BLACK. THE SUGAR COOKIE TIP OF THE WAND IS YELLOW OUTLINED IN TAN, WITH PURPLE, BLUE, YELLOW, TEAL GREEN AND BROWN SPRINKLES.

FOR SWEET BAKERY GOODS; COOKIES (U.S. CL. 46).
FIRST USE 5-21-2011; IN COMMERCE 5-21-2011.

CLASS 30—(Continued).

4,119,535. FIGUEROA, MELVIN, NEW YORK, NY. SN 85-237,665. PUB. 10-25-2011, FILED 2-9-2011.

IMPERIAL YUCATAN HONEY

THE MARK CONSISTS OF STANDARD CHARACTERS WITHOUT CLAIM TO ANY PARTICULAR FONT, STYLE, SIZE, OR COLOR.

NO CLAIM IS MADE TO THE EXCLUSIVE RIGHT TO USE "HONEY", APART FROM THE MARK AS SHOWN. FOR HONEY (U.S. CL. 46).
FIRST USE 1-1-2012; IN COMMERCE 1-1-2012.

4,119,567. FOSTER, KATHRYN, STUDIO CITY, CA. SN 85-255,080. PUB. 7-26-2011, FILED 3-1-2011.

TIME FOR TOFFEE

THE MARK CONSISTS OF STANDARD CHARACTERS WITHOUT CLAIM TO ANY PARTICULAR FONT, STYLE, SIZE, OR COLOR.

NO CLAIM IS MADE TO THE EXCLUSIVE RIGHT TO USE "TOFFEE", APART FROM THE MARK AS SHOWN. FOR CANDY (U.S. CL. 46).
FIRST USE 1-1-2012; IN COMMERCE 1-1-2012.

4,119,588. DELICIAS DE MICHOACAN, INC., ONTARIO, CA. SN 85-263,311. PUB. 8-9-2011, FILED 3-10-2011.



NO CLAIM IS MADE TO THE EXCLUSIVE RIGHT TO USE "MICHOACAN" AND "PALETAS FINAS", APART FROM THE MARK AS SHOWN.

THE MARK CONSISTS OF A CREST DESIGN WITH A

CLASS 30—(Continued).

CROWN AT THE TOP. THE WORD "DELICIAS" IN A BANNER UNDER THE CROWN. AN IMAGE OF MOUNTAINS, AN ISLAND WITH A STATUTE SURROUNDED BY WATER, AND A PERSON IN A ROWBOAT FACING THE ISLAND AND MOUNTAINS ARE INSIDE THE CREST. THE WORDS "DE MICHOACAN" APPEAR ABOVE THE MOUNTAINS. FIVE IRREGULAR TRAPEZOIDS ARE CENTERED AT THE BASE OF THE CREST. AN IRREGULAR TRAPEZOID BELOW THE CREST WITH THE WORDS "PALETAS" AND "FINAS" INSIDE.

THE ENGLISH TRANSLATION OF THE WORD "DELICIAS" AND "PALETAS FINAS" IN THE MARK IS "DELIGHTS" AND "FINE FREEZER POPS".

FOR FROZEN NOVELTIES AND CONFECTIONS, NAMELY, ICE CREAMS, FROZEN FRUIT BARS, FREEZER POPS, AND SQUEEZE POPS (U.S. CL. 46).

FIRST USE 3-30-2011; IN COMMERCE 3-30-2011.

4,119,643. BELLA FOUR BAKERY, INC., CARSON CITY, NV. SN 85-299,202. PUB. 9-6-2011, FILED 4-19-2011.

ENERGY FOR LIFE'S GREAT JOURNEYS

THE MARK CONSISTS OF STANDARD CHARACTERS WITHOUT CLAIM TO ANY PARTICULAR FONT, STYLE, SIZE, OR COLOR.

FOR BAKERY GOODS (U.S. CL. 46).
FIRST USE 9-1-2011; IN COMMERCE 9-1-2011.

CLASS 31—NATURAL AGRICULTURAL PRODUCTS

4,118,959. COLIMAN GRUPO SA DE CV, TECOMAN, MEXICO. SN 77-866,059. PUB. 4-26-2011, FILED 11-5-2009.

ROSITA

THE MARK CONSISTS OF STANDARD CHARACTERS WITHOUT CLAIM TO ANY PARTICULAR FONT, STYLE, SIZE, OR COLOR.

FOR FRESH AVOCADOS; RAW AVOCADOS; UNPROCESSED AVOCADOS (U.S. CLS. 1 AND 46).

FIRST USE 7-20-2011; IN COMMERCE 7-20-2011.

CLASS 31—(Continued).

4,119,050. PIONEER HI-BRED INTERNATIONAL, INC., JOHNSTON, IA. SN 77-982,891. PUB. 7-14-2009, FILED 3-10-2009.

Plenish

THE MARK CONSISTS OF STANDARD CHARACTERS WITHOUT CLAIM TO ANY PARTICULAR FONT, STYLE, SIZE, OR COLOR.
FOR AGRICULTURAL SEEDS (U.S. CLS. 1 AND 46).
FIRST USE 5-3-2011; IN COMMERCE 5-3-2011.

4,119,153. BURKMANN INDUSTRIES, INC., DANVILLE, KY. SN 85-063,946. PUB. 11-16-2010, FILED 6-16-2010.

TROPHY RACK

THE MARK CONSISTS OF STANDARD CHARACTERS WITHOUT CLAIM TO ANY PARTICULAR FONT, STYLE, SIZE, OR COLOR.
FOR ANIMAL FEED (U.S. CLS. 1 AND 46).
FIRST USE 1-4-2012; IN COMMERCE 1-4-2012.

4,119,220. THE HARTZ MOUNTAIN CORPORATION, SECAUCUS, NJ. SN 85-101,062. PUB. 11-16-2010, FILED 8-5-2010.



OWNER OF U.S. REG. NOS. 3,124,059, 3,781,214, AND OTHERS.
NO CLAIM IS MADE TO THE EXCLUSIVE RIGHT TO USE "DENTIST'S BEST DENTAL CHEW" AND "FOR CLEANER TEETH", APART FROM THE MARK AS SHOWN.

CLASS 31—(Continued).

THE MARK CONSISTS OF THE WORD "HARTZ" WITHIN A SQUARE OVER THE WORDS "DENTIST'S BEST DENTAL CHEW"; THE APOSTROPHE IN THE WORD "DENTIST'S" IS A DESIGN OF A TOOTH; THESE WORDS ARE SURROUNDED BY A SEMI CIRCLE; AT THE END OF THE SEMI CIRCLE IS A SHIELD DESIGN WITH THE WORDS "WITH DENTASHIELD FOR CLEANER TEETH".
FOR EDIBLE PET TREATS (U.S. CLS. 1 AND 46).
FIRST USE 3-0-2011; IN COMMERCE 3-0-2011.

4,119,569. CHURCH & DWIGHT CO., INC., PRINCETON, NJ. SN 85-256,555. PUB. 7-19-2011, FILED 3-3-2011.

ULTRA LAST

THE MARK CONSISTS OF STANDARD CHARACTERS WITHOUT CLAIM TO ANY PARTICULAR FONT, STYLE, SIZE, OR COLOR.
FOR CAT LITTER (U.S. CLS. 1 AND 46).
FIRST USE 12-9-2011; IN COMMERCE 12-9-2011.

4,119,626. EXPORTALIZAS MEXICANAS SA DE CV, CULIACÁN SINALOA, MEXICO. SN 85-290,966. PUB. 8-23-2011, FILED 4-9-2011.

THUNDER

THE MARK CONSISTS OF STANDARD CHARACTERS WITHOUT CLAIM TO ANY PARTICULAR FONT, STYLE, SIZE, OR COLOR.
FOR FRESH FRUITS AND VEGETABLES (U.S. CLS. 1 AND 46).
FIRST USE 3-16-2011; IN COMMERCE 1-10-2012.

4,119,712. SERRANI, PATRICE, SANTA BARBARA, CA. SN 85-354,612. PUB. 11-8-2011, FILED 6-23-2011.

Love The Dust

THE MARK CONSISTS OF STANDARD CHARACTERS WITHOUT CLAIM TO ANY PARTICULAR FONT, STYLE, SIZE, OR COLOR.
FOR DOG TREATS (U.S. CLS. 1 AND 46).
FIRST USE 5-18-2011; IN COMMERCE 5-18-2011.

CLASS 32—LIGHT BEVERAGES

4,118,807. NEW BEVERAGE INSIGHTS JUICEWORKS, LLLP, ORLANDO, FL. SN 77-352,160. PUB. 11-11-2008, FILED 12-14-2007.

DRENCHERS

THE MARK CONSISTS OF STANDARD CHARACTERS WITHOUT CLAIM TO ANY PARTICULAR FONT, STYLE, SIZE, OR COLOR.

FOR NON-ALCOHOLIC BEVERAGES, NAMELY, VEGETABLE JUICES (U.S. CLS. 45, 46 AND 48).
FIRST USE 4-30-2008; IN COMMERCE 4-30-2008.

4,118,813. BERTHELSEN, GEIR, KRISTIANSAND, NORWAY. SN 77-388,457. PUB. 11-11-2008, FILED 2-5-2008.

SlowCola

THE MARK CONSISTS OF STANDARD CHARACTERS WITHOUT CLAIM TO ANY PARTICULAR FONT, STYLE, SIZE, OR COLOR.

FOR NON-ALCOHOLIC DRINKS, NAMELY, CARBONATED BEVERAGES (U.S. CLS. 45, 46 AND 48).
FIRST USE 1-4-2012; IN COMMERCE 1-4-2012.

4,118,815. BERTHELSEN, GEIR, KRISTIANSAND, NORWAY. SN 77-402,443. PUB. 11-11-2008, FILED 2-21-2008.

SlowWater

THE MARK CONSISTS OF STANDARD CHARACTERS WITHOUT CLAIM TO ANY PARTICULAR FONT, STYLE, SIZE, OR COLOR.

FOR MINERAL AND AERATED WATERS; NON-ALCOHOLIC DRINKING WATER (U.S. CLS. 45, 46 AND 48).
FIRST USE 1-4-2012; IN COMMERCE 1-4-2012.

CLASS 32—(Continued).

4,118,816. BERTHELSEN, GEIR, KRISTIANSAND, NORWAY. SN 77-402,627. PUB. 11-11-2008, FILED 2-21-2008.

SlowBeverages

THE MARK CONSISTS OF STANDARD CHARACTERS WITHOUT CLAIM TO ANY PARTICULAR FONT, STYLE, SIZE, OR COLOR.

FOR BEERS; MINERAL AND AERATED WATERS AND OTHER NON-ALCOHOLIC DRINKS; FRUIT DRINKS AND FRUIT JUICES; PREPARATIONS FOR MAKING NON-ALCOHOLIC BEVERAGES, NAMELY, CARBONATED BEVERAGES (U.S. CLS. 45, 46 AND 48).
FIRST USE 1-4-2012; IN COMMERCE 1-4-2012.

4,118,853. MECKAUER, FREDERICK, SANTA BARBARA, CA. SN 77-500,362. PUB. 11-11-2008, FILED 6-16-2008.

BOARD RIDER

THE MARK CONSISTS OF STANDARD CHARACTERS WITHOUT CLAIM TO ANY PARTICULAR FONT, STYLE, SIZE, OR COLOR.

FOR BEER (U.S. CLS. 45, 46 AND 48).
FIRST USE 1-18-2012; IN COMMERCE 1-18-2012.

4,118,880. KOREA GINSENG CORP., TAEJON CITY, REPUBLIC OF KOREA. SN 77-621,494. PUB. 2-16-2010, FILED 11-25-2008.



OWNER OF U.S. REG. NOS. 2,200,666 AND 2,226,502.
NO CLAIM IS MADE TO THE EXCLUSIVE RIGHT TO USE "SINCE 1899", "KOREAN RED GINSENG" AND THE NON-LATIN CHARACTERS THAT TRANSLATE TO "6 YEAR OLD ROOTS" AND "KOREAN GINSENG", APART FROM THE MARK AS SHOWN.

CLASS 32—(Continued).

THE MARK CONSISTS OF TWO CABLES CONNECTING AT THE TOP TO A CIRCLE AND CONNECTING AT THE BOTTOM TO TWO CLOUD FORMATIONS NEXT TO THE NUMBER "6". THE MARK FEATURES FOUR ROWS OF THREE STARS, THE WORDING "SINCE 1899" AND SINO-KOREAN CHARACTERS THAT TRANSLITERATE TO "CHONG KWAN CHANG", "KORYO SAM" AND "NYEON-GEUN". BELOW THE NUMBER "6" IS A BANNER FEATURING THE WORDING "KOREAN RED GINSENG".

THE NON-LATIN CHARACTERS IN THE MARK TRANSLITERATE TO "CHONG KWAN CHANG", "KORYO SAM" AND "6 NYEON-GEUN" AND THIS MEANS "HIGH RANKING GOVERNMENT OFFICIAL", "KOREAN GINSENG" AND "6 YEAR OLD ROOTS" IN ENGLISH.

FOR BEERS, MINERAL AND AERATED WATERS, LITHIA WATER, TABLE WATERS, DRINKING WATERS, FRUIT DRINKS AND FRUIT JUICES, SYRUPS, CONCENTRATES AND POWDERS USED IN THE PREPARATION OF SOFT DRINKS, SOFT DRINK CONTAINING GINSENG, GINSENG JUICE, SPORTS DRINKS CONTAINING GINSENG, CONCENTRATED GINSENG JUICE (U.S. CLS. 45, 46 AND 48).

FIRST USE 1-19-2012; IN COMMERCE 1-19-2012.

4,118,893. SIMPLY ORANGE JUICE COMPANY, APOPKA, FL. SN 77-651,409. PUB. 5-5-2009, FILED 1-16-2009.

HONESTAMENTE SIMPLE

THE MARK CONSISTS OF STANDARD CHARACTERS WITHOUT CLAIM TO ANY PARTICULAR FONT, STYLE, SIZE, OR COLOR.

OWNER OF U.S. REG. NO. 3,516,189.

THE ENGLISH TRANSLATION OF "HONESTAMENTE SIMPLE" IN THE MARK IS "HONESTLY SIMPLE".

FOR NON-ALCOHOLIC BEVERAGES, NAMELY, FRUIT DRINKS AND FRUIT JUICES (U.S. CLS. 45, 46 AND 48).

FIRST USE 5-0-2010; IN COMMERCE 5-0-2010.

4,118,944. HEALTH2O PRODUCTS, LLC, DALLAS, TX. SN 77-833,128. PUB. 12-21-2010, FILED 9-23-2009.

CELLULAR O₂ ON DEMAND

NO CLAIM IS MADE TO THE EXCLUSIVE RIGHT TO USE "O₂", APART FROM THE MARK AS SHOWN.

THE MARK CONSISTS OF THE WORDS, LETTERS AND NUMBERS "CELLULAR O₂ ON DEMAND" WITH THE NUMBER "2" BEING IN SUBSCRIPT.

FOR NON-ALCOHOLIC, LOW-CALORIE, NON-CARBONATED BEVERAGES, NAMELY, BOTTLED WATER AND FLAVORED WATER (U.S. CLS. 45, 46 AND 48).

FIRST USE 8-21-2009; IN COMMERCE 9-12-2009.

CLASS 32—(Continued).

4,119,021. COMERCIALIZADORA ELORO, S.A., ESTADO DE MEXICO, MEXICO. SN 77-929,357. PUB. 6-15-2010, FILED 2-5-2010.

AMI FRUIT PUNCH

THE MARK CONSISTS OF STANDARD CHARACTERS WITHOUT CLAIM TO ANY PARTICULAR FONT, STYLE, SIZE, OR COLOR.

OWNER OF U.S. REG. NOS. 3,064,686 AND 3,122,274.

NO CLAIM IS MADE TO THE EXCLUSIVE RIGHT TO USE "FRUIT PUNCH", APART FROM THE MARK AS SHOWN.

FOR FRUIT DRINKS (U.S. CLS. 45, 46 AND 48).

FIRST USE 7-10-2009; IN COMMERCE 7-10-2009.

4,119,331. ROLLING MEADOWS BREWERY LLC, AKA ROLLING MEADOWS BREWERY, CANTRALL, IL. SN 85-179,086. PUB. 5-3-2011, FILED 11-17-2010.

**LINCOLN'S
LOGGER**

THE MARK CONSISTS OF STANDARD CHARACTERS WITHOUT CLAIM TO ANY PARTICULAR FONT, STYLE, SIZE, OR COLOR.

NO CLAIM IS MADE TO THE EXCLUSIVE RIGHT TO USE "LAGER", APART FROM THE MARK AS SHOWN.

FOR BEER, ALE AND LAGER (U.S. CLS. 45, 46 AND 48).

FIRST USE 4-30-2011; IN COMMERCE 12-15-2011.

CLASS 32—(Continued).

4,119,352. BIRRA RONZANI S.R.L., SAN GIOVANNI IN PERSICETO (BOLOGNA), ITALY. SN 85-187,937. PUB. 5-10-2011, FILED 12-1-2010.



NO CLAIM IS MADE TO THE EXCLUSIVE RIGHT TO USE "BIRRA", "ANTICA BIRRERIA LIQUORERIA" AND "FONDATA NEL 1855 IN BOLOGNA - ITALY", APART FROM THE MARK AS SHOWN.

THE MARK CONSISTS OF FOUR CONCENTRIC OVALS. TOWARDS THE TOP OF THE OVALS IS A CIRCLE CONTAINING A DESIGN OF A CAULDRON AND BEER BREWING IMPLEMENTS AND THE WORDING "BIRRA" INSIDE A CURVED RECTANGLE. IN THE CENTER OF THE OVALS IS A ROUNDED TRIANGLE CONTAINING THE WORDING "BIRRA RONZANI ANTICA BIRRERIA . LIQUORERIA FONDATA NEL 1855 IN BOLOGNA - ITALY". UNDERNEATH THIS WORDING IS A DESIGN OF A STALK OF GRAIN. TOWARDS THE BOTTOM OF THE OVALS IS THE WORDING "ORO DEL RENO".

THE ENGLISH TRANSLATION OF "BIRRA, BIRRA RONZANI, ANTICA BIRRERIA LIQUORERIA, FONDATA NEL 1855 IN BOLOGNA - ITALY" AND "ORO DEL RENO" IN THE MARK IS BEER, RONZANI BEER, OLD BREWERY DISTILLERY, ESTABLISHED IN 1855 IN BOLOGNA - ITALY AND GOLD OF THE RIVER RENO.
FOR BEERS (U.S. CLS. 45, 46 AND 48).
FIRST USE 5-24-2010; IN COMMERCE 10-17-2011.

4,119,678. GLAS, ROBERT, WALKER VALLEY, NY. AND YOVANE, GREGORY, CORTLANDT MANOR, NY. SN 85-323,592. PUB. 10-25-2011, FILED 5-18-2011.

Beer Water The Responsible Alternative

THE MARK CONSISTS OF STANDARD CHARACTERS WITHOUT CLAIM TO ANY PARTICULAR FONT, STYLE, SIZE, OR COLOR.

NO CLAIM IS MADE TO THE EXCLUSIVE RIGHT TO USE "BEER WATER", APART FROM THE MARK AS SHOWN.

FOR BOTTLED WATER (U.S. CLS. 45, 46 AND 48).
FIRST USE 3-4-2011; IN COMMERCE 12-20-2011.

CLASS 33—WINES AND SPIRITS**CLASS 33—(Continued).**

4,118,888. KRASI LIMITED LIABILITY COMPANY, FORT WASHINGTON, PA. SN 77-643,430. PUB. 4-28-2009, FILED 1-5-2009.

KARAMOOR ESTATE

THE MARK CONSISTS OF STANDARD CHARACTERS WITHOUT CLAIM TO ANY PARTICULAR FONT, STYLE, SIZE, OR COLOR.

NO CLAIM IS MADE TO THE EXCLUSIVE RIGHT TO USE "ESTATE", APART FROM THE MARK AS SHOWN.

FOR WINE (U.S. CLS. 47 AND 49).
FIRST USE 1-12-2012; IN COMMERCE 1-12-2012.

4,118,941. ANANTA AH WINE INCORPORATED, SAN LUIS OBISPO, CA. SN 77-821,187. PUB. 2-9-2010, FILED 9-6-2009.

AnanTaah

THE MARK CONSISTS OF STANDARD CHARACTERS WITHOUT CLAIM TO ANY PARTICULAR FONT, STYLE, SIZE, OR COLOR.

THE ENGLISH TRANSLATION OF "ANANTA AH" IS UNLIMITED OR ENDLESS.

FOR WINES (U.S. CLS. 47 AND 49).
FIRST USE 9-12-2011; IN COMMERCE 9-12-2011.

4,119,066. VICENTIN S.A.I.C, SANTA FE, ARGENTINA. SN 85-004,118. PUB. 12-7-2010, FILED 4-1-2010.

VICENTIN

THE MARK CONSISTS OF STANDARD CHARACTERS WITHOUT CLAIM TO ANY PARTICULAR FONT, STYLE, SIZE, OR COLOR.

THE WORD(S) "VICENTIN" HAS NO MEANING IN A FOREIGN LANGUAGE.

FOR WINES (U.S. CLS. 47 AND 49).
FIRST USE 11-22-2011; IN COMMERCE 11-22-2011.

CLASS 33—(Continued).

4,119,075. BODEGA DANTE ROBINO S.A., BUENOS AIRES, ARGENTINA. SN 85-013,976. PUB. 5-17-2011, FILED 4-14-2010.

CALDEN

THE MARK CONSISTS OF STANDARD CHARACTERS WITHOUT CLAIM TO ANY PARTICULAR FONT, STYLE, SIZE, OR COLOR.

FOR WINES (U.S. CLS. 47 AND 49).
FIRST USE 12-26-2011; IN COMMERCE 12-26-2011.

4,119,081. PATERNO IMPORTS, LTD., DBA TERLATO WINES INTERNATIONAL, LAKE BLUFF, IL. SN 85-019,093. PUB. 7-20-2010, FILED 4-21-2010.

PURE SNOW

THE MARK CONSISTS OF STANDARD CHARACTERS WITHOUT CLAIM TO ANY PARTICULAR FONT, STYLE, SIZE, OR COLOR.

FOR SAKE (U.S. CLS. 47 AND 49).
FIRST USE 9-16-2011; IN COMMERCE 9-16-2011.

4,119,091. GANSU BINHE FOODSTUFF INDUSTRY GROUP CO. LTD, GANSU PROVINCE, CHINA. SN 85-031,378. PUB. 4-26-2011, FILED 5-6-2010.

THE MARK CONSISTS OF CHINESE CHARACTERS WHICH TRANSLITERATE TO "GUO FENG".

CLASS 33—(Continued).

THE NON-LATIN CHARACTERS IN THE MARK TRANSLITERATE TO "GUO" AND THIS MEANS "COUNTRY WIND" IN ENGLISH.

FOR ABSINTHE; ALCOHOLIC APERITIF BITTERS; ALCOHOLIC BEVERAGE PRODUCED FROM A BREWED MALT BASE WITH NATURAL FLAVORS; ALCOHOLIC BEVERAGES OF FRUIT; ALCOHOLIC BEVERAGES EXCEPT BEERS; ALCOHOLIC BEVERAGES, NAMELY, FLAVOR-INFUSED WHISKEY; ALCOHOLIC BEVERAGES, NAMELY, DIGESTIFS; ALCOHOLIC BITTERS; ALCOHOLIC COCKTAIL MIXES; ALCOHOLIC COCKTAILS CONTAINING MILK; ALCOHOLIC COFFEE-BASED BEVERAGE; ALCOHOLIC EGG NOG; ALCOHOLIC ENERGY DRINKS; ALCOHOLIC ESSENCES; ALCOHOLIC EXTRACTS; ALCOHOLIC FRUIT COCKTAIL DRINKS; ALCOHOLIC FRUIT EXTRACTS; ALCOHOLIC MALT COOLERS; ALCOHOLIC PUNCH; ALCOHOLIC PUNCHES; ALCOHOLIC TEA-BASED BEVERAGE; AMONTILLADO; ANISE; ANISETTE; APERITIF WINES; APERITIFS; APERITIFS WITH A DISTILLED ALCOHOLIC LIQUOR BASE; APERITIFS WITH A WINE BASE; AQUAVIT; ARAK; ARMAGNAC; ARRACK; BLACKCURRANT LIQUEUR; BOURBON; BRANDY; BRANDY SPIRITS; CHACHACA; CALVADOS; CHAMPAGNE; CHERRY BRANDY; CHINESE BREWED LIQUOR, NAMELY, LAOJIOU; CHINESE MIXED LIQUOR, NAMELY, WUJIAPIEJIOU; CHINESE SPIRIT OF SORGHUM, NAMELY, GAOLIANJIOU; CHINESE WHITE LIQUOR, NAMELY, BAIGANR; COFFEE-BASED LIQUEURS; COGNAC; COOKING BRANDY; COOKING WINE; CORDIALS; CREAM LIQUEURS; CURACAO; DISTILLED SPIRITS; DISTILLED SPIRITS OF RICE, NAMELY, AWAMORI; EXTRACTS OF SPIRITUOUS LIQUORS; FLAVORED BREWED MALT BEVERAGE; FORTIFIED WINES; FRENCH BRANDY; FRUIT WINE; GIN; GRAPE WINE; GRAPPA; HARD CIDER; HERB LIQUEURS; HONEY WINE; JAPANESE REGENERATED LIQUORS, NAMELY, NAOSHI; JAPANESE SHOCHU-BASED MIXED LIQUOR, NAMELY, MIRIN; JAPANESE SWEET RICE-BASED MIXED LIQUOR, NAMELY, SHIRO-ZAKE; JAPANESE WHITE LIQUOR, NAMELY, SHOCHU; KIRSCH; KITS FOR MAKING WINE; LIQUEURS; DISTILLED LIQUOR; MEAD; MESCAL; NATURAL SPARKLING WINES; OUZO; PERRY; POMMEAU; PORT; PORT WINES; POTABLE SPIRITS; PREPARED ALCOHOLIC COCKTAIL; PREPARED WINE COCKTAILS; RED WINES; RUM; RUM INFUSED WITH VITAMINS; SAKE; SAMBUCA; SANGRIA; SCHNAPPS; SCOTCH; SHERRY; SPARKLING FRUIT WINE; SPARKLING GRAPE WINE; SPARKLING WINES; SPIRITS AND LIQUEURS; STILL WINES; STRAWBERRY WINE; SUGAR CANE JUICE RUM; SWEET WINES; TABLE WINES; TEQUILA; TEQUILA INFUSED WITH VITAMINS; TONIC LIQUOR CONTAINING HERB EXTRACTS, NAMELY, HOMEISHU; VERMOUTH; VODKA; WHISKY; WHITE WINE; WINE COOLERS; WINE PUNCHES; WINES; WINES AND FORTIFIED WINES; WINES AND LIQUEURS; WINES AND SPARKLING WINES; WINE-BASED DRINKS (U.S. CLS. 47 AND 49).
FIRST USE 5-6-2011; IN COMMERCE 5-6-2011.

4,119,411. SPANISH VINES, INC., COLUMBIA, SC. SN 85-202,326. PUB. 4-26-2011, FILED 12-20-2010.

LUZ ETERNA

THE MARK CONSISTS OF STANDARD CHARACTERS WITHOUT CLAIM TO ANY PARTICULAR FONT, STYLE, SIZE, OR COLOR.

CLASS 33—(Continued).

THE ENGLISH TRANSLATION OF "LUZ ETERNA" IN THE MARK IS ETERNAL LIGHT.
FOR WINE (U.S. CLS. 47 AND 49).
FIRST USE 5-0-2011; IN COMMERCE 5-0-2011.

4,119,412. SPANISH VINES, INC., COLUMBIA, SC. SN 85-202,328. PUB. 4-26-2011, FILED 12-20-2010.

AMARTE MAS

THE MARK CONSISTS OF STANDARD CHARACTERS WITHOUT CLAIM TO ANY PARTICULAR FONT, STYLE, SIZE, OR COLOR.

THE ENGLISH TRANSLATION OF "AMARTE MAS" IN THE MARK IS TO LOVE YOU MORE.
FOR WINE (U.S. CLS. 47 AND 49).
FIRST USE 5-0-2011; IN COMMERCE 5-0-2011.

4,119,449. SMITH, GINEVRA CASA, WALLA WALLA, WA. AND SMITH, CHARLES, WALLA WALLA, WA. SN 85-211,396. PUB. 5-17-2011, FILED 1-5-2011.



NO CLAIM IS MADE TO THE EXCLUSIVE RIGHT TO USE "VINO", APART FROM THE MARK AS SHOWN.

THE MARK CONSISTS OF THE WORDING "VINO", WITH THE "I" BEING REPRESENTED BY A WINE BOTTLE WITH A RECTANGULAR BORDER.

THE ENGLISH TRANSLATION OF "VINO" IN THE MARK IS "WINE".

FOR WINES (U.S. CLS. 47 AND 49).
FIRST USE 0-0-2011; IN COMMERCE 0-0-2011.

CLASS 33—(Continued).

4,119,461. BAROUDI, FRANK M, DBA PURO UNO, NAPLES, FL. SN 85-214,371. PUB. 6-14-2011, FILED 1-10-2011.

PURO DOS

THE MARK CONSISTS OF STANDARD CHARACTERS WITHOUT CLAIM TO ANY PARTICULAR FONT, STYLE, SIZE, OR COLOR.

THE ENGLISH TRANSLATION OF THE WORD "PURO DOS" IN THE MARK IS "PURE TWO".

FOR RED WINE; RED WINES; SPARKLING WINES; STILL WINES; SWEET WINES; TABLE WINES; WHITE WINE; WINE; WINES; WINES AND FORTIFIED WINES; WINES AND LIQUEURS; WINES AND SPARKLING WINES (U.S. CLS. 47 AND 49).

FIRST USE 10-5-2011; IN COMMERCE 1-15-2012.

4,119,536. MICHAEL AVETISOV, SHERMAN OAKS, CA. SN 85-237,762. PUB. 6-21-2011, FILED 2-9-2011.

LION HEAD

THE MARK CONSISTS OF STANDARD CHARACTERS WITHOUT CLAIM TO ANY PARTICULAR FONT, STYLE, SIZE, OR COLOR.

FOR DISTILLED SPIRITS; VODKA (U.S. CLS. 47 AND 49).

FIRST USE 9-9-2011; IN COMMERCE 12-23-2011.

4,119,582. VYENIELO, CHRIS, SAN RAFAEL, CA. SN 85-261,292. PUB. 7-26-2011, FILED 3-8-2011.



THE MARK CONSISTS OF A TELEPHONE.
FOR WINES (U.S. CLS. 47 AND 49).
FIRST USE 3-29-2011; IN COMMERCE 3-29-2011.

CLASS 33—(Continued).

4,119,662. T & BEER, INC. DBA SIMONE INTERNATIONAL, OLD TAPPAN, NJ. SN 85-309,620. PUB. 9-20-2011, FILED 5-2-2011.

COQUETTE

THE MARK CONSISTS OF STANDARD CHARACTERS WITHOUT CLAIM TO ANY PARTICULAR FONT, STYLE, SIZE, OR COLOR.
FOR WINES AND LIQUEURS (U.S. CLS. 47 AND 49).
FIRST USE 9-5-2011; IN COMMERCE 9-5-2011.

4,119,699. PERRUCCI, GREG. LOS GATOS, CA. SN 85-340,619. PUB. 11-15-2011, FILED 6-8-2011.

MESCOLANZA

THE MARK CONSISTS OF STANDARD CHARACTERS WITHOUT CLAIM TO ANY PARTICULAR FONT, STYLE, SIZE, OR COLOR.
THE ENGLISH TRANSLATION OF THE WORD "MESCOLANZA" IN THE MARK IS "MIXTURE".
FOR WINES (U.S. CLS. 47 AND 49).
FIRST USE 10-1-2010; IN COMMERCE 10-1-2010.

4,119,710. SUN LIQUOR MFG, INC., SEATTLE, WA. SN 85-354,074. PUB. 11-8-2011, FILED 6-23-2011.

HEDGE TRIMMER

THE MARK CONSISTS OF STANDARD CHARACTERS WITHOUT CLAIM TO ANY PARTICULAR FONT, STYLE, SIZE, OR COLOR.
FOR DISTILLED SPIRITS; GIN (U.S. CLS. 47 AND 49).
FIRST USE 10-31-2011; IN COMMERCE 10-31-2011.

CLASS 33—(Continued).

4,119,731. PROXIMO SPIRITS, INC., JERSEY CITY, NJ. SN 85-976,261. PUB. 7-5-2011, FILED 7-16-2010.

STRANAHAN'S

THE MARK CONSISTS OF STANDARD CHARACTERS WITHOUT CLAIM TO ANY PARTICULAR FONT, STYLE, SIZE, OR COLOR.
OWNER OF U.S. REG. NO. 3,295,856.
SEC. 2(F).
FOR ALCOHOLIC BEVERAGES, EXCEPT BEERS (U.S. CLS. 47 AND 49).
FIRST USE 1-24-2007; IN COMMERCE 1-24-2007.

CLASS 34—SMOKERS' ARTICLES

4,118,850. NATIONAL TOBACCO COMPANY, L.P., LOUISVILLE, KY. SN 77-496,351. PUB. 11-10-2009, FILED 6-11-2008.

DURANGO

THE MARK CONSISTS OF STANDARD CHARACTERS WITHOUT CLAIM TO ANY PARTICULAR FONT, STYLE, SIZE, OR COLOR.
OWNER OF U.S. REG. NOS. 2,518,530 AND 2,624,913.
FOR SMOKELESS TOBACCO (U.S. CLS. 2, 8, 9 AND 17).
FIRST USE 3-3-1998; IN COMMERCE 3-3-1998.

CLASS 35—ADVERTISING AND BUSINESS

4,118,754. AMERISOURCE HERITAGE CORPORATION, WILMINGTON, DE. SN 76-691,611. PUB. 11-4-2008, FILED 7-28-2008.

THE POWER L

THE MARK CONSISTS OF STANDARD CHARACTERS WITHOUT CLAIM TO ANY PARTICULAR FONT, STYLE, SIZE, OR COLOR.
FOR WHOLESALE DISTRIBUTORSHIP SERVICES FEATURING PHARMACEUTICALS, HEALTH AND BEAUTY AIDS (U.S. CLS. 100, 101 AND 102).
FIRST USE 12-31-2008; IN COMMERCE 12-31-2008.

CLASS 35—(Continued).

4,118,755. GROUP CARES, LOVELAND, CO. SN 76-696,469. PUB. 11-10-2009, FILED 3-23-2009.

GROUP CARES

THE MARK CONSISTS OF STANDARD CHARACTERS WITHOUT CLAIM TO ANY PARTICULAR FONT, STYLE, SIZE, OR COLOR.

OWNER OF U.S. REG. NOS. 3,097,206 AND 3,147,254.

NO CLAIM IS MADE TO THE EXCLUSIVE RIGHT TO USE "GROUP", APART FROM THE MARK AS SHOWN.

FOR GATHERING VOLUNTEERS AND ARRANGING FOR VOLUNTEERS TO WORK WITH HUMAN SERVICE ORGANIZATIONS, CHURCHES AND LOCAL AGENCIES OR DIRECTLY WITH ELDERLY, DISABLED OR DISADVANTAGED PERSONS TO PROVIDE ASSISTANCE AND HOME REPAIR TO NEEDY PERSONS (U.S. CLS. 100, 101 AND 102).

FIRST USE 12-1-2010; IN COMMERCE 12-1-2010.

4,118,760. PRACTICEGENIUS LLC, SAN DIEGO, CA. SN 76-702,742. PUB. 5-31-2011, FILED 4-28-2010.



NO CLAIM IS MADE TO THE EXCLUSIVE RIGHT TO USE "MARKETING", APART FROM THE MARK AS SHOWN.

THE MARK CONSISTS OF THE WORDING "PRACTICEGENIUS" WITH AN ELLIPTICAL DESIGN CONSISTING OF TWO OVALS ABOVE THE WORDING "GENIUS" AND THE WORDING "MARKETING" AND "EVOLVE" APPEARING BELOW THE WORDING "PRACTICEGENIUS".

FOR MARKETING CONSULTATION THROUGH THE INTERNET IN THE FIELD OF HEALTH AND DENTAL PROFESSIONS; BUSINESS MANAGEMENT SERVICES THROUGH THE INTERNET, NAMELY, ADMINISTRATION OF BUSINESS ENGAGED IN HEALTH AND DENTAL PROFESSIONS (U.S. CLS. 100, 101 AND 102).

FIRST USE 7-21-2009; IN COMMERCE 7-21-2009.

4,118,761. PRACTICEGENIUS LLC, SAN DIEGO, CA. SN 76-702,798. PUB. 6-7-2011, FILED 4-28-2010.

PRACTICEGENIUS

THE MARK CONSISTS OF STANDARD CHARACTERS WITHOUT CLAIM TO ANY PARTICULAR FONT, STYLE, SIZE, OR COLOR.

FOR MARKETING CONSULTATION THROUGH THE INTERNET IN THE FIELD OF HEALTH AND DENTAL PROFESSIONS; BUSINESS MANAGEMENT AND CONSULTING SERVICES FOR THE HEALTH CARE INDUSTRY, NAMELY, CUSTOMER SERVICE, ACCOUNTING SERVICES, AND WEB-BASED ADVERTISING AND MARKETING SERVICES (U.S. CLS. 100, 101 AND 102).

FIRST USE 7-21-2009; IN COMMERCE 7-21-2009.

CLASS 35—(Continued).

4,118,783. LAKESIDE COLLABORATIVE, INC., NEW YORK, NY. SN 77-159,917. PUB. 11-11-2008, FILED 4-18-2007.

ZONA

THE MARK CONSISTS OF STANDARD CHARACTERS WITHOUT CLAIM TO ANY PARTICULAR FONT, STYLE, SIZE, OR COLOR.

THE FOREIGN WORDING IN THE MARK TRANSLATES INTO ENGLISH AS ZONE.

FOR RETAIL STORE SERVICES FEATURING HOME FURNISHINGS AND HOME DESIGN ACCESSORIES; MAIL ORDER SERVICES FEATURING HOME FURNISHINGS, HOME DESIGN ACCESSORIES, APPAREL, HANDBAGS, LUGGAGE, PERFUMES, ESSENTIAL OILS AND CANDLES (U.S. CLS. 100, 101 AND 102).

FIRST USE 12-2-2011; IN COMMERCE 12-2-2011.

4,118,798. PICCIONELLI, GREGORY A., ENCINO, CA. SN 77-330,185. PUB. 11-11-2008, FILED 11-15-2007.

THE THIRD PARTY

THE MARK CONSISTS OF STANDARD CHARACTERS WITHOUT CLAIM TO ANY PARTICULAR FONT, STYLE, SIZE, OR COLOR.

FOR PROVIDING A WEBSITE FEATURING INFORMATION ON POLITICAL ELECTIONS, POLITICAL ISSUES, VOTER REGISTRATION, AND CANDIDATE INFORMATION; POLITICAL PARTY COMMITTEE SERVICES, NAMELY, PROMOTING AND ADVOCATING THE INTERESTS OF A POLITICAL PARTY IN THE FIELD OF POLITICS; AND PROMOTING AND ADVOCATING THE NEED FOR A NATIONAL INITIATIVE LAWMAKING PROCESS (U.S. CLS. 100, 101 AND 102).

FIRST USE 2-2-2012; IN COMMERCE 2-2-2012.

4,118,803. WINE FATHER, LLC, CHICAGO, IL. SN 77-345,427. PUB. 10-28-2008, FILED 12-6-2007.

PREDATOR ARBITRAGE

THE MARK CONSISTS OF STANDARD CHARACTERS WITHOUT CLAIM TO ANY PARTICULAR FONT, STYLE, SIZE, OR COLOR.

CLASS 35—(Continued).

NO CLAIM IS MADE TO THE EXCLUSIVE RIGHT TO USE "ARBITRAGE", APART FROM THE MARK AS SHOWN.

FOR ON-LINE ADVERTISING AND MARKETING SERVICES; ADVERTISING AND PROMOTIONAL SERVICES; PRICE COMPARISON SERVICES (U.S. CLS. 100, 101 AND 102).

FIRST USE 1-10-2012; IN COMMERCE 1-10-2012.

CLASS 35—(Continued).

4,118,881. MANDALAY REAL ESTATE LIMITED, NEUCHÂTEL, SWITZERLAND. SN 77-623,909. PUB. 4-14-2009, FILED 12-1-2008.

JEAN MACHINE

THE MARK CONSISTS OF STANDARD CHARACTERS WITHOUT CLAIM TO ANY PARTICULAR FONT, STYLE, SIZE, OR COLOR.

NO CLAIM IS MADE TO THE EXCLUSIVE RIGHT TO USE "JEAN", APART FROM THE MARK AS SHOWN.

FOR RETAIL STORE SERVICES IN THE FIELD OF APPAREL AND BELTS (U.S. CLS. 100, 101 AND 102).

FIRST USE 12-1-2011; IN COMMERCE 12-1-2011.

4,118,826. RADWELL INTERNATIONAL INC., LUMBERTON, NJ. SN 77-456,988. PUB. 10-28-2008, FILED 4-24-2008.

KAVJO

THE MARK CONSISTS OF STANDARD CHARACTERS WITHOUT CLAIM TO ANY PARTICULAR FONT, STYLE, SIZE, OR COLOR.

FOR DISTRIBUTORSHIP SERVICES IN THE FIELD OF ELECTRONIC EQUIPMENT; ONLINE ORDERING SERVICES FEATURING INDUSTRIAL AUTOMATION EQUIPMENT (U.S. CLS. 100, 101 AND 102).

FIRST USE 1-18-2012; IN COMMERCE 1-18-2012.

4,118,900. PANDORA JEWELRY, LLC, COLUMBIA, MD. SN 77-690,744. PUB. 1-12-2010, FILED 3-13-2009.

PANDORA

OWNER OF U.S. REG. NO. 3,065,374.

THE MARK CONSISTS OF A STYLIZED ICON USED IN THE PLACE OF THE LETTER "O" WITHIN THE WORD "PANDORA".

FOR RETAIL STORE SERVICES FEATURING JEWELRY AND OTHER FASHION ACCESSORIES (U.S. CLS. 100, 101 AND 102).

FIRST USE 5-0-2008; IN COMMERCE 6-0-2008.

4,118,833. JENNIFER C. SANT'ANNA, SAN JOSE, CA. SN 77-467,992. PUB. 11-25-2008, FILED 5-7-2008.

VERDE VILLAGE

THE MARK CONSISTS OF STANDARD CHARACTERS WITHOUT CLAIM TO ANY PARTICULAR FONT, STYLE, SIZE, OR COLOR.

NO CLAIM IS MADE TO THE EXCLUSIVE RIGHT TO USE "VERDE", APART FROM THE MARK AS SHOWN.

THE ENGLISH TRANSLATION OF "VERDE" IN THE MARK IS "GREEN."

FOR ONLINE RETAIL STORE SERVICES FEATURING ENVIRONMENTALLY FRIENDLY PRODUCTS, NAMELY, REUSABLE SHOPPING BAGS, WATER BOTTLES, AND LUNCH BOXES (U.S. CLS. 100, 101 AND 102).

FIRST USE 2-8-2012; IN COMMERCE 2-8-2012.

4,118,908. SUSTAINONE, LLC, WOODLAND, WA. SN 77-717,362. PUB. 8-25-2009, FILED 4-20-2009.



NO CLAIM IS MADE TO THE EXCLUSIVE RIGHT TO USE "SUPPLIER DIVERSITY", APART FROM THE MARK AS SHOWN.

CLASS 35—(Continued).

THE MARK CONSISTS OF THE WORDS "SUSTAINONE" WITH THE "O" IN "ONE" COMPRISING A GLOBE AND THE WORDS "SUPPLIER DIVERSITY" UNDERNEATH.

FOR DISTRIBUTORSHIP SERVICES IN THE FIELD OF PAPER PRODUCTS AND JANITORIAL SUPPLIES (U.S. CLS. 100, 101 AND 102).

FIRST USE 12-31-2011; IN COMMERCE 12-31-2011.

CLASS 35—(Continued).

4,118,958. INVESTING IN YOUR DESTINY, LLC, AUSTIN, TX. SN 77-865,210. PUB. 4-26-2011, FILED 11-4-2009.

QUICK STEPS TO

4,118,909. SUSTAINONE, LLC, WOODLAND, WA. SN 77-717,374. PUB. 8-25-2009, FILED 4-20-2009.

THE MARK CONSISTS OF STANDARD CHARACTERS WITHOUT CLAIM TO ANY PARTICULAR FONT, STYLE, SIZE, OR COLOR.

FOR PROVIDING A WEB SITE AND INFORMATION IN THE FIELDS OF MARKETING, BUSINESS DEVELOPMENT AND ON-LINE MARKETING MEDIA VIA THE INTERNET, PODCASTS AND CELL PHONES DOWNLOADS (U.S. CLS. 100, 101 AND 102).

FIRST USE 12-16-2011; IN COMMERCE 12-16-2011.

SUSTAINONE

4,118,967. HOT SPOTS EARTH INCORPORATED, BEAVERTON, OR. SN 77-877,047. PUB. 10-26-2010, FILED 11-20-2009.

THE MARK CONSISTS OF STANDARD CHARACTERS WITHOUT CLAIM TO ANY PARTICULAR FONT, STYLE, SIZE, OR COLOR.

FOR DISTRIBUTORSHIP SERVICES IN THE FIELD OF PAPER PRODUCTS AND JANITORIAL SUPPLIES (U.S. CLS. 100, 101 AND 102).

FIRST USE 12-31-2011; IN COMMERCE 12-31-2011.

**Hot Spots Earth
Incorporated**

THE MARK CONSISTS OF STANDARD CHARACTERS WITHOUT CLAIM TO ANY PARTICULAR FONT, STYLE, SIZE, OR COLOR.

NO CLAIM IS MADE TO THE EXCLUSIVE RIGHT TO USE "INCORPORATED", APART FROM THE MARK AS SHOWN.

FOR ADVERTISING AND COMMERCIAL INFORMATION SERVICES, VIA THE INTERNET (U.S. CLS. 100, 101 AND 102).

FIRST USE 12-4-2009; IN COMMERCE 12-4-2009.

4,118,937. MEGAWAVE CORPORATION, LANSING, MI. SN 77-809,352. PUB. 4-26-2011, FILED 8-20-2009.

A HIGHER CALLING

4,118,985. THRIVENT FINANCIAL FOR LUTHERANS, APPLETON, WI. SN 77-897,960. PUB. 5-17-2011, FILED 12-21-2009.

THE MARK CONSISTS OF STANDARD CHARACTERS WITHOUT CLAIM TO ANY PARTICULAR FONT, STYLE, SIZE, OR COLOR.

FOR DISTRIBUTORSHIPS IN THE FIELDS OF VIDEO AND SOUND RECORDINGS, CDS, DVDS AND PHONOGRAPH RECORDS; ON-LINE DISTRIBUTORSHIP SERVICES FEATURING DOWNLOADABLE SOUND, MUSIC, IMAGE AND VIDEO FILES (U.S. CLS. 100, 101 AND 102).

FIRST USE 1-12-2010; IN COMMERCE 1-12-2010.

CHOICE DOLLARS

THE MARK CONSISTS OF STANDARD CHARACTERS WITHOUT CLAIM TO ANY PARTICULAR FONT, STYLE, SIZE, OR COLOR.

NO CLAIM IS MADE TO THE EXCLUSIVE RIGHT TO USE "DOLLARS", APART FROM THE MARK AS SHOWN.

CLASS 35—(Continued).

"DOLLARS" APPEARING IN THE MARK HAS NO SIGNIFICANCE NOR IS IT A TERM OF ART IN THE RELEVANT TRADE OR INDUSTRY OR AS APPLIED TO THE GOODS/SERVICES LISTED IN THE APPLICATION, OR ANY GEOGRAPHICAL SIGNIFICANCE.

FOR PROMOTING AND ADMINISTERING A LOYALTY INCENTIVE PROGRAM TO PROMOTE CHARITABLE PURPOSES (U.S. CLS. 100, 101 AND 102).

FIRST USE 7-0-2010; IN COMMERCE 7-0-2010.

4,119,000. IGNITE MEDIA SOLUTIONS, LLC, OLDSMAR, FL. SN 77-913,114. PUB. 12-28-2010, FILED 1-15-2010.

HERCLE

THE MARK CONSISTS OF STANDARD CHARACTERS WITHOUT CLAIM TO ANY PARTICULAR FONT, STYLE, SIZE, OR COLOR.

FOR BUSINESS MARKETING MANAGEMENT SERVICES (U.S. CLS. 100, 101 AND 102).

FIRST USE 11-20-2009; IN COMMERCE 7-5-2010.

4,119,046. GEORGIA-PACIFIC LLC, ATLANTA, GA. SN 77-961,903. PUB. 6-22-2010, FILED 3-18-2010.

GP HEALTHSMART

THE MARK CONSISTS OF STANDARD CHARACTERS WITHOUT CLAIM TO ANY PARTICULAR FONT, STYLE, SIZE, OR COLOR.

OWNER OF U.S. REG. NOS. 1,581,414, 1,603,264, AND 3,139,736.

FOR PROMOTING PUBLIC AWARENESS OF THE IMPORTANCE OF PROPER HAND WASHING (U.S. CLS. 100, 101 AND 102).

FIRST USE 8-30-2011; IN COMMERCE 8-30-2011.

CLASS 35—(Continued).

4,119,070. MIRATEC SYSTEMS, INC, SAINT PAUL, MN. SN 85-004,522. PUB. 6-14-2011, FILED 4-1-2010.



NO CLAIM IS MADE TO THE EXCLUSIVE RIGHT TO USE A RED AND BLACK PLAID SHIRT, APART FROM THE MARK AS SHOWN.

THE COLOR(S) BLUE, YELLOW, TAN, BROWN, RED, GREEN, BLACK, AND WHITE IS/ARE CLAIMED AS A FEATURE OF THE MARK.

THE MARK CONSISTS OF THE FOLLOWING A SMILING CHARACTER WHO IS DEPICTED AS HAVING LIGHT TAN SKIN, BLUE EYES, AND YELLOW EYEBROWS AS WEARING A RED AND BLACK PLAID SHIRT, BROWN SUSPENDERS, A WHITE UNDERSHIRT, AND A GREEN HAT THAT CONTAINS A BROWN UNDERSIDE. THE FIGURE IS OUTLINED IN BLACK. IN HIS EYES, THE PUPILS ARE BLACK WITH A WHITE DOT, THEN BLUE AND WHITE.

FOR ONLINE SERVICES FEATURING VISUAL COMMUNICATIONS PRODUCTS, SERVICES AND SUPPLIES IN THE NATURE OF PROVIDING ONLINE BUSINESS INFORMATION CONCERNING THE PURCHASE OF VISUAL COMMUNICATIONS PRODUCTS, NAMELY, PROVIDING ONLINE PRICE ESTIMATES, PROVIDING CUSTOMER ORDER STATUS INFORMATION, PROVIDING AUTOMATIC PRICE QUOTATIONS, PROVIDING PRODUCT AVAILABILITY INFORMATION AND PROVIDING PRODUCT DELIVERY AND PURCHASE ORDER TRACKING INFORMATION; PROVIDING AN ONLINE COMPUTER DATABASE FEATURING CONSUMER PRODUCT INFORMATION IN THE FIELD OF VISUAL COMMUNICATIONS PRODUCTS; PROVIDING ONLINE ORDERING SERVICES FEATURING VISUAL COMMUNICATIONS PRODUCTS; PROVIDING AN ONLINE COMPUTER DATABASE FEATURING CUSTOMER SERVICES IN THE FIELD OF VISUAL COMMUNICATIONS PRODUCTS, NAMELY, PROVIDING AN ON-LINE COMPUTER DATABASE IN THE FIELD OF LOCATING PRODUCTS, DESCRIBING PRODUCTS, AND PRICING PRODUCTS (U.S. CLS. 100, 101 AND 102).

FIRST USE 4-8-2010; IN COMMERCE 4-8-2010.

CLASS 35—(Continued).

4,119,074. LAMONTE WINSTON, OVERLAND PARK, KS. SN 85-013,696. PUB. 5-17-2011, FILED 4-14-2010.



NO CLAIM IS MADE TO THE EXCLUSIVE RIGHT TO USE "GROUP", APART FROM THE MARK AS SHOWN.

THE MARK CONSISTS OF THE PHRASE "THE WINSTON GROUP" WITH THE INDIVIDUAL LETTERS "T", "W" AND "G" DISPOSED ABOVE THE PHRASE AGAINST A RECTANGULAR BACKDROP AND A STYLIZED, ENLARGED LETTER "W" LATERALLY DISPOSED TO THE INDIVIDUALIZED LETTERS.

FOR BUSINESS MANAGEMENT CONSULTING IN THE FIELD OF SPORTS (U.S. CLS. 100, 101 AND 102).

FIRST USE 6-1-2011; IN COMMERCE 6-1-2011.

CLASS 35—(Continued).

4,119,099. MOTION1, INC., CARMEL, IN. SN 85-037,578. PUB. 5-10-2011, FILED 5-13-2010.

MOTION1

THE MARK CONSISTS OF STANDARD CHARACTERS WITHOUT CLAIM TO ANY PARTICULAR FONT, STYLE, SIZE, OR COLOR.

FOR DISTRIBUTORSHIP SERVICES IN THE FIELDS OF PHYSICAL THERAPY PRODUCTS AND REHABILITATION PRODUCTS USED BY PHYSICAL THERAPISTS, OCCUPATIONAL THERAPISTS, CHIROPRACTORS, ATHLETIC TRAINERS, SPORTS MEDICINE PRACTITIONERS, CLINICS AND OTHERS IN THE MEDICAL FIELD; CATALOG ORDERING SERVICES FEATURING CLINICAL SUPPLIES, CLINICAL EQUIPMENT, THERAPEUTIC PRODUCTS, EXERCISE EQUIPMENT, PATIENT CARE PRODUCTS, MEDICAL DIAGNOSTIC AND EVALUATION EQUIPMENT, HYDROTHERAPY PRODUCTS AND ORTHOPEDIC PRODUCTS (U.S. CLS. 100, 101 AND 102).

FIRST USE 4-24-2010; IN COMMERCE 4-24-2010.

4,119,101. OPTERRA ENERGY GROUP, INC., WESTMINSTER, CO. SN 85-038,391. PUB. 5-3-2011, FILED 5-14-2010.

OPTERRA ENERGY GROUP

THE MARK CONSISTS OF STANDARD CHARACTERS WITHOUT CLAIM TO ANY PARTICULAR FONT, STYLE, SIZE, OR COLOR.

NO CLAIM IS MADE TO THE EXCLUSIVE RIGHT TO USE "ENERGY GROUP", APART FROM THE MARK AS SHOWN.

FOR BUSINESS CONSULTING AND ADVISORY SERVICES IN THE FIELD OF ENERGY EFFICIENCY; CONDUCTING ENERGY AUDITS OF COMMERCIAL AND INSTITUTIONAL FACILITIES FOR THE PURPOSE OF IMPROVING ENERGY EFFICIENCY; CONSULTATION IN THE FIELD OF ENERGY EFFICIENCY; CONSULTING SERVICES IN THE FIELD OF ENERGY EFFICIENCY FOR COMMERCIAL AND INSTITUTIONAL FACILITIES; CONSULTING SERVICES IN THE FIELD OF ENERGY USAGE MANAGEMENT AND ENERGY EFFICIENCY; CONSULTING SERVICES IN THE FIELDS OF ENERGY CONSUMPTION AND USAGE CONSERVATION TO IMPROVE ENERGY EFFICIENCY; ENERGY AUDITING; INFORMATION IN THE FIELD OF ENERGY EFFICIENCY (U.S. CLS. 100, 101 AND 102).

FIRST USE 6-13-2011; IN COMMERCE 6-13-2011.

4,119,087. AOL INC., DULLES, VA. SN 85-027,410. PUB. 10-5-2010, FILED 4-30-2010.

ADVISIBILITY

THE MARK CONSISTS OF STANDARD CHARACTERS WITHOUT CLAIM TO ANY PARTICULAR FONT, STYLE, SIZE, OR COLOR.

FOR ADVERTISING, MARKETING, AND PROMOTIONAL SERVICES; PLACEMENT, DISSEMINATION, AND TARGETING OF ADVERTISING FOR OTHERS VIA THE INTERNET, COMPUTER NETWORKS, AND DIGITAL NETWORKS (U.S. CLS. 100, 101 AND 102).

FIRST USE 2-14-2011; IN COMMERCE 2-14-2011.

CLASS 35—(Continued).

4,119,104. SAN PASQUAL CASINO DEVELOPMENT GROUP INC., VALLEY CENTER, CA. SN 85-039,142. PUB. 10-19-2010, FILED 5-14-2010.

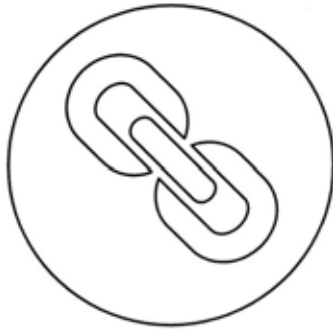

THE MARK CONSISTS OF A CIRCLE WITH A CHAIN LINK INSIDE.

FOR ADVERTISING AND MARKETING; COOPERATIVE ADVERTISING AND MARKETING (U.S. CLS. 100, 101 AND 102).

FIRST USE 7-0-2010; IN COMMERCE 7-0-2010.

4,119,210. KAY GROUP NO. 2 PTY LTD, PORT MELBOURNE, AUSTRALIA. SN 85-093,135. PUB. 5-31-2011, FILED 7-26-2010.

606 Product Networker

THE MARK CONSISTS OF STANDARD CHARACTERS WITHOUT CLAIM TO ANY PARTICULAR FONT, STYLE, SIZE, OR COLOR.

NO CLAIM IS MADE TO THE EXCLUSIVE RIGHT TO USE "PRODUCT NETWORKER", APART FROM THE MARK AS SHOWN.

FOR ADVERTISING AND MARKETING SERVICES; PUBLICITY AGENTS; ADVERTISING SERVICES, NAMELY, PUBLISHING OF ADVERTISING TEXTS IN ELECTRONIC MEDIA; ONLINE ADVERTISING ON COMPUTER DATA COMMUNICATIONS NETWORKS; PUBLICITY OF ADVERTISING MATERIAL ON-LINE, NAMELY, ADVERTISING BY TRANSMISSION OF ON-LINE PUBLICITY FOR THIRD PARTIES THROUGH ELECTRONIC COMMUNICATIONS NETWORKS; ON-LINE PROMOTION OF COMPUTER WEBSITES; PROVIDING CONSUMER PRODUCT INFORMATION VIA THE INTERNET (U.S. CLS. 100, 101 AND 102).

FIRST USE 8-0-2010; IN COMMERCE 8-0-2010.

CLASS 35—(Continued).

4,119,218. UREFER, INC., DBA AMPLIFINITY, INC., ANN ARBOR, MI. SN 85-098,394. PUB. 5-24-2011, FILED 8-2-2010.

ADVOCATE RELATIONSHIP MANAGEMENT (ARM)

THE MARK CONSISTS OF STANDARD CHARACTERS WITHOUT CLAIM TO ANY PARTICULAR FONT, STYLE, SIZE, OR COLOR.

NO CLAIM IS MADE TO THE EXCLUSIVE RIGHT TO USE "RELATIONSHIP MANAGEMENT", APART FROM THE MARK AS SHOWN.

FOR MARKETING CONSULTING SERVICES (U.S. CLS. 100, 101 AND 102).

FIRST USE 1-18-2012; IN COMMERCE 1-18-2012.

4,119,290. MMJIP, LLC, SAN FRANCISCO, CA. SN 85-149,717. PUB. 9-13-2011, FILED 10-11-2010.

SPARC

THE MARK CONSISTS OF STANDARD CHARACTERS WITHOUT CLAIM TO ANY PARTICULAR FONT, STYLE, SIZE, OR COLOR.

FOR PUBLIC ADVOCACY TO PROMOTE AWARENESS OF THE NEED FOR ASSURING PATIENTS SAFE ACCESS TO AFFORDABLE MEDICINE THAT MEDICAL CANNABIS PROVIDES; PROMOTING TECHNICAL AND SCIENTIFIC INVESTIGATION, RESEARCH, AND EXPERIMENTATION IN THE FIELD OF ADVANCEMENT OF THE APPLICATION OF SCIENTIFIC DISCOVERY FOR THE BETTERMENT OF HUMANKIND THROUGH SUPPORT OF EDUCATIONAL INSTITUTIONS AND SCIENTIFIC ORGANIZATIONS; PUBLIC ADVOCACY TO PROMOTE AWARENESS OF MEDICAL CANNABIS (U.S. CLS. 100, 101 AND 102).

FIRST USE 6-7-2010; IN COMMERCE 6-7-2010.

4,119,298. PILLAR HOTELS AND RESORTS, L.P., IRVING, TX. SN 85-154,973. PUB. 5-3-2011, FILED 10-18-2010.

PILLAR HOTELS AND RESORTS

THE MARK CONSISTS OF STANDARD CHARACTERS WITHOUT CLAIM TO ANY PARTICULAR FONT, STYLE, SIZE, OR COLOR.

CLASS 35—(Continued).

NO CLAIM IS MADE TO THE EXCLUSIVE RIGHT TO USE "HOTELS AND RESORTS", APART FROM THE MARK AS SHOWN.

FOR BUSINESS AND ADMINISTRATIVE MANAGEMENT OF HOTEL AND RESORT PROPERTIES FOR OTHERS (U.S. CLS. 100, 101 AND 102).

FIRST USE 10-0-2010; IN COMMERCE 10-0-2010.

4,119,303. PWG HOLDINGS, LLC, LAKE MARY, FL. SN 85-158,779. PUB. 1-25-2011, FILED 10-22-2010.



OWNER OF U.S. REG. NO. 3,356,391.
NO CLAIM IS MADE TO THE EXCLUSIVE RIGHT TO USE "WEDDING GUIDE", APART FROM THE MARK AS SHOWN.

THE COLOR(S) PINK IS/ARE CLAIMED AS A FEATURE OF THE MARK.

THE MARK CONSISTS OF THE WORDS "PERFECT WEDDING GUIDE" STYLIZED IN PINK LETTERS.

SEC. 2(F).

FOR ADVERTISING, MARKETING AND PROMOTION SERVICES; PROMOTING AND CONDUCTING TRADE SHOWS FEATURING WEDDING AND HONEYMOON PRODUCTS AND SERVICES; ADVERTISING SERVICES IN THE FIELD OF WEDDING AND HONEYMOON PRODUCTS AND SERVICES, PROVIDING A WEBSITE FEATURING ADVERTISEMENTS REGARDING WEDDING AND HONEYMOON PRODUCTS AND SERVICES; PROVIDING A CONSUMER INFORMATION DATABASE IN THE FIELD OF WEDDING AND HONEYMOON PRODUCTS AND SERVICES (U.S. CLS. 100, 101 AND 102).

FIRST USE 7-30-2010; IN COMMERCE 9-1-2010.

4,119,306. REBATECITY.COM LLC, WILMINGTON, DE. SN 85-160,291. PUB. 4-19-2011, FILED 10-25-2010.

REBATECITY

THE MARK CONSISTS OF STANDARD CHARACTERS WITHOUT CLAIM TO ANY PARTICULAR FONT, STYLE, SIZE, OR COLOR.

FOR PROVIDING AN INTERNET WEBSITE PORTAL FEATURING LINKS TO THE GOODS OF OTHERS IN THE FIELD OF GENERAL CONSUMER MERCHANDISE FOR RETAIL PURPOSES (U.S. CLS. 100, 101 AND 102).

FIRST USE 12-15-2011; IN COMMERCE 12-15-2011.

CLASS 35—(Continued).

4,119,326. ATLANCO, INC., MARIETTA, GA. SN 85-176,767. PUB. 5-24-2011, FILED 11-15-2010.

5IVE STAR GEAR

THE MARK CONSISTS OF STANDARD CHARACTERS WITHOUT CLAIM TO ANY PARTICULAR FONT, STYLE, SIZE, OR COLOR.

NO CLAIM IS MADE TO THE EXCLUSIVE RIGHT TO USE "GEAR", APART FROM THE MARK AS SHOWN.

FOR RETAIL STORE SERVICES FEATURING MILITARY SURPLUS AND CAMPING, HUNTING, MILITARY, POLICE AND SECURITY GEAR (U.S. CLS. 100, 101 AND 102).

FIRST USE 6-0-2011; IN COMMERCE 6-0-2011.

4,119,375. MEDNEST, LIMITED LIABILITY COMPANY, PRINCETON, NJ. SN 85-195,129. PUB. 10-11-2011, FILED 12-10-2010.

DERMANEST

THE MARK CONSISTS OF STANDARD CHARACTERS WITHOUT CLAIM TO ANY PARTICULAR FONT, STYLE, SIZE, OR COLOR.

FOR BUSINESS CONSULTING SERVICES IN THE FIELD OF PROVIDING ASSISTANCE IN DEVELOPMENT OF BUSINESS STRATEGIES AND CREATIVE IDEATION FOR DOMESTIC, AND INTERNATIONAL COSMETIC AND SKIN CARE COMPANIES TO IMPLEMENT THEIR GROWTH STRATEGIES WITHIN THEIR RESPECTIVE MARKETS (U.S. CLS. 100, 101 AND 102).

FIRST USE 12-12-2009; IN COMMERCE 7-26-2011.

4,119,392. HRB INNOVATIONS, INC., LAS VEGAS, NV. SN 85-198,377. PUB. 4-19-2011, FILED 12-15-2010.

NO TE CONFORMES CON MENOS

THE MARK CONSISTS OF STANDARD CHARACTERS WITHOUT CLAIM TO ANY PARTICULAR FONT, STYLE, SIZE, OR COLOR.

THE ENGLISH TRANSLATION OF "NO TE CONFORMES CON MENOS" IN THE MARK IS "NEVER SETTLE FOR LESS".

FOR TAX PREPARATION, TAX CONSULTATION AND TAX FILING SERVICES (U.S. CLS. 100, 101 AND 102).

FIRST USE 1-0-2011; IN COMMERCE 1-0-2011.

CLASS 35—(Continued).

4,119,407. THE DALLAS CONVENTION & VISITORS BUREAU, DALLAS, TX. SN 85-201,580. PUB. 5-10-2011, FILED 12-20-2010.



OWNER OF U.S. REG. NOS. 3,096,149 AND 3,096,150.
NO CLAIM IS MADE TO THE EXCLUSIVE RIGHT TO USE "DALLAS" AND "SPORTS", APART FROM THE MARK AS SHOWN.

THE MARK CONSISTS OF THE STYLIZED WORD "DALLAS" APPEARING ABOVE THE WORDS "LIVE LARGE. THINK BIG", AND THE WORD "SPORTS" APPEARING WITHIN A RECTANGLE BELOW THE LETTERS "NK" AND THE WORD "BIG".

FOR ADVERTISING AND BUSINESS SERVICES, NAMELY, PROMOTING BUSINESS, CONVENTIONS AND TOURISM IN THE CITY OF DALLAS, TEXAS (U.S. CLS. 100, 101 AND 102).

FIRST USE 1-14-2011; IN COMMERCE 1-14-2011.

4,119,410. CHG MANAGEMENT, INC., SALT LAKE CITY, UT. SN 85-202,001. PUB. 4-26-2011, FILED 12-20-2010.

YOUR WISH IS OUR COMMAND

THE MARK CONSISTS OF STANDARD CHARACTERS WITHOUT CLAIM TO ANY PARTICULAR FONT, STYLE, SIZE, OR COLOR.

FOR HEALTHCARE RECRUITING AND STAFFING SERVICES (U.S. CLS. 100, 101 AND 102).

FIRST USE 9-0-2010; IN COMMERCE 9-0-2010.

CLASS 35—(Continued).

4,119,426. COTTERWEB ENTERPRISES, INC., MENDOTA HEIGHTS, MN. SN 85-204,718. PUB. 10-25-2011, FILED 12-23-2010.



THE MARK CONSISTS OF AN ANIMATED MONETARY BILL WITH ARMS, FEET AND A SMILEY FACE, WHICH IS LEANING ON ITS LEFT FOOT.

FOR CUSTOMER LOYALTY SERVICES FOR COMMERCIAL, PROMOTIONAL AND/OR ADVERTISING PURPOSES WHICH REWARDS CONSUMERS FOR READING EMAIL ADVERTISED MESSAGES AND COMPLETING ONLINE ACTIVITIES INCLUDING, ONLINE SHOPPING, MARKET RESEARCH SURVEYS AND PLAYING ONLINE GAMES; ONLINE ADVERTISING AND MARKETING SERVICES (U.S. CLS. 100, 101 AND 102).

FIRST USE 12-14-2010; IN COMMERCE 12-14-2010.

4,119,427. COTTERWEB ENTERPRISES, INC., MENDOTA HEIGHTS, MN. SN 85-204,719. PUB. 10-25-2011, FILED 12-23-2010.

THE ONLINE REWARDS CLUB THAT PAYS

THE MARK CONSISTS OF STANDARD CHARACTERS WITHOUT CLAIM TO ANY PARTICULAR FONT, STYLE, SIZE, OR COLOR.

NO CLAIM IS MADE TO THE EXCLUSIVE RIGHT TO USE "ONLINE REWARDS CLUB", APART FROM THE MARK AS SHOWN.

FOR CUSTOMER LOYALTY SERVICES FOR COMMERCIAL, PROMOTIONAL AND/OR ADVERTISING PURPOSES WHICH REWARDS CONSUMERS FOR READING EMAIL ADVERTISED MESSAGES AND COMPLETING ONLINE ACTIVITIES INCLUDING, ONLINE SHOPPING, MARKET RESEARCH SURVEYS AND PLAYING ONLINE GAMES; ONLINE ADVERTISING AND MARKETING SERVICES (U.S. CLS. 100, 101 AND 102).

FIRST USE 12-14-2010; IN COMMERCE 12-14-2010.

CLASS 35—(Continued).

4,119,452. WASNICK, STEVE, ST. ANTHONY, MN. SN 85-212,515. PUB. 5-3-2011, FILED 1-7-2011.

WINNING CAUSE

THE MARK CONSISTS OF STANDARD CHARACTERS WITHOUT CLAIM TO ANY PARTICULAR FONT, STYLE, SIZE, OR COLOR.

FOR ONLINE AUCTION SERVICES (U.S. CLS. 100, 101 AND 102).

FIRST USE 1-27-2011; IN COMMERCE 1-27-2011.

4,119,453. WASNICK, STEVE, ST. ANTHONY, MN. SN 85-212,517. PUB. 5-3-2011, FILED 1-7-2011.



THE MARK CONSISTS OF A RIBBON FOLDED IN THE SHAPE OF A PERSON WITH ARMS RAISED IN THE FORM OF A "W".

FOR ONLINE AUCTION SERVICES (U.S. CLS. 100, 101 AND 102).

FIRST USE 1-27-2011; IN COMMERCE 1-27-2011.

4,119,471. RICHARD A. WALKER, ALPHARETTA, GA. SN 85-217,507. PUB. 5-31-2011, FILED 1-13-2011.

NCAMA

THE MARK CONSISTS OF STANDARD CHARACTERS WITHOUT CLAIM TO ANY PARTICULAR FONT, STYLE, SIZE, OR COLOR.

FOR ASSOCIATION SERVICES, NAMELY, PROMOTING THE INTERESTS OF THOSE INVOLVED IN THE AUTOMOTIVE INDUSTRY (U.S. CLS. 100, 101 AND 102).

FIRST USE 1-14-2011; IN COMMERCE 5-15-2011.

CLASS 35—(Continued).

4,119,479. SEBAGO USA, LLC, ROCKFORD, MI. SN 85-220,621. PUB. 5-3-2011, FILED 1-19-2011.

SEBAGO

THE MARK CONSISTS OF STANDARD CHARACTERS WITHOUT CLAIM TO ANY PARTICULAR FONT, STYLE, SIZE, OR COLOR.

OWNER OF U.S. REG. NOS. 1,301,822, 2,401,830, AND OTHERS.

FOR RETAIL STORE SERVICES FEATURING FOOTWEAR, CLOTHING, HEADGEAR, BAGS, AND ACCESSORIES; ON-LINE RETAIL STORE SERVICES FEATURING FOOTWEAR, CLOTHING, BAGS, AND ACCESSORIES (U.S. CLS. 100, 101 AND 102).

FIRST USE 10-7-2010; IN COMMERCE 10-7-2010.

4,119,485. THE CONNECTED TABLE, INC., NEW YORK, NY. SN 85-221,588. PUB. 5-17-2011, FILED 1-19-2011.

THE CONNECTED TABLE

THE MARK CONSISTS OF STANDARD CHARACTERS WITHOUT CLAIM TO ANY PARTICULAR FONT, STYLE, SIZE, OR COLOR.

FOR ADVERTISING SERVICES; BRANDING SERVICES, NAMELY, CONSULTING, DEVELOPMENT, MANAGEMENT AND MARKETING OF BRANDS FOR BUSINESSES; EVENT PLANNING AND MANAGEMENT FOR MARKETING, BRANDING, PROMOTING OR ADVERTISING THE GOODS AND SERVICES OF OTHERS; PROVIDING MARKETING AND PROMOTION OF SPECIAL EVENTS; PUBLIC RELATIONS (U.S. CLS. 100, 101 AND 102).

FIRST USE 2-0-2011; IN COMMERCE 2-0-2011.

CLASS 35—(Continued).

4,119,486. THE CONNECTED TABLE, INC., NEW YORK, NY. SN 85-221,598. PUB. 5-17-2011, FILED 1-19-2011.

EAT DRINK EXPLORE INSPIRE

THE MARK CONSISTS OF STANDARD CHARACTERS WITHOUT CLAIM TO ANY PARTICULAR FONT, STYLE, SIZE, OR COLOR.

FOR ADVERTISING SERVICES; BRANDING SERVICES, NAMELY, CONSULTING, DEVELOPMENT, MANAGEMENT AND MARKETING OF BRANDS FOR BUSINESSES; EVENT PLANNING AND MANAGEMENT FOR MARKETING, BRANDING, PROMOTING OR ADVERTISING THE GOODS AND SERVICES OF OTHERS; PROVIDING MARKETING AND PROMOTION OF SPECIAL EVENTS; PUBLIC RELATIONS (U.S. CLS. 100, 101 AND 102).

FIRST USE 2-0-2011; IN COMMERCE 2-0-2011.

4,119,496. EQUIPATRON, LLC, MILWAUKEE, WI. SN 85-223,662. PUB. 5-24-2011, FILED 1-21-2011.

Product Cloud

THE MARK CONSISTS OF STANDARD CHARACTERS WITHOUT CLAIM TO ANY PARTICULAR FONT, STYLE, SIZE, OR COLOR.

NO CLAIM IS MADE TO THE EXCLUSIVE RIGHT TO USE "PRODUCT", APART FROM THE MARK AS SHOWN.

FOR BUSINESS CONSULTATION SERVICES IN THE FIELD OF TANGIBLE MANUFACTURED PRODUCTS (U.S. CLS. 100, 101 AND 102).

FIRST USE 1-13-2012; IN COMMERCE 1-13-2012.

4,119,497. ENK INTERNATIONAL, LLC, NEW YORK, NY. SN 85-224,647. PUB. 5-31-2011, FILED 1-24-2011.

ENKCHINA

THE MARK CONSISTS OF STANDARD CHARACTERS WITHOUT CLAIM TO ANY PARTICULAR FONT, STYLE, SIZE, OR COLOR.

OWNER OF U.S. REG. NO. 1,795,214.

FOR ARRANGING AND CONDUCTING TRADE SHOWS IN THE FIELD OF CLOTHING AND FASHION ACCESSORIES (U.S. CLS. 100, 101 AND 102).

FIRST USE 9-1-2010; IN COMMERCE 9-1-2010.

CLASS 35—(Continued).

4,119,503. INTERNATIONAL VENDING MANAGEMENT, INC., INDIANAPOLIS, IN. SN 85-225,750. PUB. 5-31-2011, FILED 1-25-2011.

IVM

THE MARK CONSISTS OF STANDARD CHARACTERS WITHOUT CLAIM TO ANY PARTICULAR FONT, STYLE, SIZE, OR COLOR.

FOR MANAGING THE VENDING MACHINES OF OTHERS; PROVIDING VENDING MACHINE SERVICES TO OTHERS (U.S. CLS. 100, 101 AND 102).

FIRST USE 10-0-2003; IN COMMERCE 10-0-2003.

4,119,517. FOSTER & ADOPTIVE CARE COALITION, ST. LOUIS, MO. SN 85-230,262. PUB. 7-26-2011, FILED 1-31-2011.

REFRESH: A FASHION
COALITION

THE MARK CONSISTS OF STANDARD CHARACTERS WITHOUT CLAIM TO ANY PARTICULAR FONT, STYLE, SIZE, OR COLOR.

NO CLAIM IS MADE TO THE EXCLUSIVE RIGHT TO USE "FASHION COALITION", APART FROM THE MARK AS SHOWN.

FOR RETAIL STORES FEATURING USED CLOTHING (U.S. CLS. 100, 101 AND 102).

FIRST USE 6-20-2011; IN COMMERCE 6-20-2011.

4,119,541. WALKER, RICHARD A., ALPHARETTA, GA. SN 85-240,592. PUB. 5-31-2011, FILED 2-11-2011.

SAMA

THE MARK CONSISTS OF STANDARD CHARACTERS WITHOUT CLAIM TO ANY PARTICULAR FONT, STYLE, SIZE, OR COLOR.

FOR ASSOCIATION SERVICES, NAMELY, PROMOTING THE INTERESTS OF THOSE INVOLVED IN THE AUTOMOTIVE INDUSTRY (U.S. CLS. 100, 101 AND 102).

FIRST USE 2-11-2011; IN COMMERCE 5-15-2011.

CLASS 35—(Continued).

4,119,558. INTERNATIONAL VENDING MANAGEMENT, INC., INDIANAPOLIS, IN. SN 85-249,471. PUB. 5-31-2011, FILED 2-23-2011.



NO CLAIM IS MADE TO THE EXCLUSIVE RIGHT TO USE "INC", APART FROM THE MARK AS SHOWN.

THE MARK CONSISTS OF THE LETTERS "IVM" EN-CIRCLED WITH A CURVED ARROW ABOVE AND A CURVED ARROW BELOW AND THE LITERAL ELEMENT "INC" APPEARING TO THE BOTTOM AND RIGHT OF THE MAIN DESIGN ELEMENT

FOR MANAGING THE VENDING MACHINES OF OTHERS; PROVIDING VENDING MACHINE SERVICES TO OTHERS (U.S. CLS. 100, 101 AND 102).

FIRST USE 3-25-2011; IN COMMERCE 3-25-2011.

CLASS 35—(Continued).

4,119,576. MUSELLO, DAMIAN R., SOMERVILLE, MA. SN 85-259,078. PUB. 8-23-2011, FILED 3-5-2011.

The Party Of the People,
By the People, For the
People

THE MARK CONSISTS OF STANDARD CHARACTERS WITHOUT CLAIM TO ANY PARTICULAR FONT, STYLE, SIZE, OR COLOR.

FOR ADVERTISING IN PERIODICALS, BROCHURES AND NEWSPAPERS; ADVERTISING IN THE POPULAR AND PROFESSIONAL PRESS; ADVERTISING SERVICES, NAMELY, CREATING CORPORATE AND BRAND IDENTITY FOR OTHERS; ADVERTISING SERVICES, NAMELY, CREATING CORPORATE AND BRAND IDENTITY FOR CANDIDATES FOR PUBLIC OFFICE, FOR CORPORATIONS WORKING IN SUPPORT OF CANDIDATES FOR PUBLIC OFFICE AND FOR ORGANIZATIONS WORKING IN SUPPORT FOR CANDIDATES FOR PUBLIC OFFICE (U.S. CLS. 100, 101 AND 102).

FIRST USE 12-21-2011; IN COMMERCE 12-21-2011.

4,119,584. FEES, TORI D., DES MOINES, IA. SN 85-262,568. PUB. 11-1-2011, FILED 3-9-2011.

4,119,575. AMIN, GRACE, AKA GRACE AMAZIN, WASHINGTON, DC. SN 85-258,955. PUB. 7-26-2011, FILED 3-5-2011.

NECESSARY PRESENCE

Daycare Whisperer

THE MARK CONSISTS OF STANDARD CHARACTERS WITHOUT CLAIM TO ANY PARTICULAR FONT, STYLE, SIZE, OR COLOR.

FOR ENTERTAINMENT MARKETING SERVICES, NAMELY, MARKETING, PROMOTION AND ADVERTISING FOR INDEPENDENT RECORDING ARTISTS (U.S. CLS. 100, 101 AND 102).

FIRST USE 3-1-2011; IN COMMERCE 3-1-2011.

THE MARK CONSISTS OF STANDARD CHARACTERS WITHOUT CLAIM TO ANY PARTICULAR FONT, STYLE, SIZE, OR COLOR.

NO CLAIM IS MADE TO THE EXCLUSIVE RIGHT TO USE "DAYCARE", APART FROM THE MARK AS SHOWN. FOR BUSINESS CONSULTING SERVICES FOR THE DAYCARE INDUSTRY (U.S. CLS. 100, 101 AND 102).

FIRST USE 3-9-2011; IN COMMERCE 3-9-2011.

CLASS 35—(Continued).

4,119,586. DORM DONKEY LLC, MIAMI, FL. SN 85-263,034.
PUB. 7-26-2011, FILED 3-10-2011.

KICKIN' CASH AROUND CAMPUS

THE MARK CONSISTS OF STANDARD CHARACTERS WITHOUT CLAIM TO ANY PARTICULAR FONT, STYLE, SIZE, OR COLOR.

FOR PROVIDING A WEB SITE WHERE MEMBERS OF ACADEMIC COMMUNITIES CAN POST ITEMS FOR SALE THROUGH ON-LINE CLASSIFIED ADVERTISEMENTS; PROVIDING AN ON-LINE SEARCHABLE DATABASE FOR MEMBERS OF ACADEMIC COMMUNITIES FEATURING CLASSIFIED AD LISTINGS (U.S. CLS. 100, 101 AND 102).
FIRST USE 5-2-2011; IN COMMERCE 5-2-2011.

4,119,587. DORM DONKEY LLC, MIAMI, FL. SN 85-263,090.
PUB. 7-26-2011, FILED 3-10-2011.

DORM DONKEY

THE MARK CONSISTS OF STANDARD CHARACTERS WITHOUT CLAIM TO ANY PARTICULAR FONT, STYLE, SIZE, OR COLOR.

FOR PROVIDING A WEB SITE WHERE MEMBERS OF ACADEMIC COMMUNITIES CAN POST ITEMS FOR SALE THROUGH ON-LINE CLASSIFIED ADVERTISEMENTS; PROVIDING AN ON-LINE SEARCHABLE DATABASE FOR MEMBERS OF ACADEMIC COMMUNITIES FEATURING CLASSIFIED AD LISTINGS (U.S. CLS. 100, 101 AND 102).
FIRST USE 5-2-2011; IN COMMERCE 5-2-2011.

4,119,641. U.S. FARMERS & RANCHERS ALLIANCE, INC., CHESTERFIELD, MO. SN 85-297,504. PUB. 8-16-2011, FILED 4-18-2011.

USFRA

THE MARK CONSISTS OF STANDARD CHARACTERS WITHOUT CLAIM TO ANY PARTICULAR FONT, STYLE, SIZE, OR COLOR.

FOR ARRANGING AND CONDUCTING TRADESHOW EXHIBITIONS IN THE FIELD OF TODAY'S MODERN AGRICULTURE (U.S. CLS. 100, 101 AND 102).
FIRST USE 3-5-2011; IN COMMERCE 3-5-2011.

CLASS 35—(Continued).

4,119,697. COMSCORE, INC., RESTON, VA. SN 85-339,383.
PUB. 10-18-2011, FILED 6-6-2011.

SOCIAL ESSENTIALS

THE MARK CONSISTS OF STANDARD CHARACTERS WITHOUT CLAIM TO ANY PARTICULAR FONT, STYLE, SIZE, OR COLOR.

FOR BUSINESS CONSULTING AND RESEARCH INFORMATION SERVICES, NAMELY, MONITORING, TRACKING, AND REPORTING OF THE USE OF DIGITAL MEDIA (U.S. CLS. 100, 101 AND 102).
FIRST USE 5-23-2011; IN COMMERCE 6-6-2011.

4,119,700. DARREN BRADY CPA PC, CHARLOTTE, NC. SN 85-340,650. PUB. 11-22-2011, FILED 6-8-2011.

EVERY TAX PROBLEM HAS A SOLUTION

THE MARK CONSISTS OF STANDARD CHARACTERS WITHOUT CLAIM TO ANY PARTICULAR FONT, STYLE, SIZE, OR COLOR.

FOR INCOME TAX CONSULTATION; INCOME TAX PREPARATION; MANAGEMENT OF TAX FILES; TAX ADVISORY SERVICES; TAX AND TAXATION PLANNING, ADVICE, INFORMATION AND CONSULTANCY SERVICES; TAX CONSULTATION; TAX FILING SERVICES; TAX PREPARATION (U.S. CLS. 100, 101 AND 102).
FIRST USE 1-1-2012; IN COMMERCE 1-1-2012.

4,119,709. SUPERVALU INC., EDEN PRAIRIE, MN. SN 85-353,001. PUB. 11-8-2011, FILED 6-22-2011.

THRIVE LIVE & EAT WELL

THE MARK CONSISTS OF STANDARD CHARACTERS WITHOUT CLAIM TO ANY PARTICULAR FONT, STYLE, SIZE, OR COLOR.

FOR RETAIL GROCERY STORE SERVICES (U.S. CLS. 100, 101 AND 102).
FIRST USE 10-28-2011; IN COMMERCE 10-28-2011.

CLASS 35—(Continued).

4,119,711. FEMININE RASCAL INC., NEW YORK, NY. SN 85-354,354. PUB. 11-8-2011, FILED 6-23-2011.

Feminin Rascal

THE MARK CONSISTS OF STANDARD CHARACTERS WITHOUT CLAIM TO ANY PARTICULAR FONT, STYLE, SIZE, OR COLOR.

FOR COMPUTERIZED ON-LINE RETAIL STORE SERVICES IN THE FIELD OF LUXURY AND FASHION CLOTHING, APPAREL, FOOTWEAR, CLOTHING ACCESSORIES, HANDBAGS AND JEWELRY (U.S. CLS. 100, 101 AND 102).

FIRST USE 12-1-2011; IN COMMERCE 12-1-2011.

CLASS 35—(Continued).

4,119,727. C. WONDER LLC, NEW YORK, NY. SN 85-976,241. PUB. 8-2-2011, FILED 4-4-2011.



THE MARK CONSISTS OF A STYLIZED LETTER "C".
FOR RETAIL STORE SERVICES FEATURING CLOTHING, JEWELRY, HOUSEWARES, STATIONERY, LEATHER GOODS AND BAGS, EYEWEAR, AND ELECTRONICS; ONLINE RETAIL STORE SERVICES FEATURING CLOTHING, FURNITURE, JEWELRY, HOUSEWARES, STATIONERY, LEATHER GOODS AND BAGS, EYEWEAR, AND ELECTRONICS (U.S. CLS. 100, 101 AND 102).

FIRST USE 10-22-2011; IN COMMERCE 10-22-2011.

4,119,717. PROGRESSIVE CASUALTY INSURANCE COMPANY, MAYFIELD VILLAGE, OH. SN 85-385,736. PUB. 10-25-2011, FILED 8-1-2011.

PROGRESSIVE PLUS

THE MARK CONSISTS OF STANDARD CHARACTERS WITHOUT CLAIM TO ANY PARTICULAR FONT, STYLE, SIZE, OR COLOR.

FOR ADMINISTRATION OF A PROGRAM FOR ENABLING PARTICIPANTS TO OBTAIN DISCOUNTS ON PRODUCTS AND SERVICES (U.S. CLS. 100, 101 AND 102).

FIRST USE 9-22-2011; IN COMMERCE 9-22-2011.

CLASS 36—INSURANCE AND FINANCIAL

4,118,797. THE RITZ-CARLTON HOTEL COMPANY, L.L.C., BETHESDA, MD. SN 77-326,121. PUB. 10-21-2008, FILED 11-9-2007.

RITZ

4,119,718. SELECT INTELLECTUAL, LLC, PITTSBURGH, PA. SN 85-392,367. PUB. 10-25-2011, FILED 8-8-2011.

SAFETYMIRROR

THE MARK CONSISTS OF STANDARD CHARACTERS WITHOUT CLAIM TO ANY PARTICULAR FONT, STYLE, SIZE, OR COLOR.

FOR BUSINESS SERVICES, NAMELY, PROVIDING PERSONNEL SELECTION AND ASSESSMENT SERVICES BY IDENTIFYING, AND SCREENING OF SAFETY ATTITUDES AND BEHAVIOR OF EMPLOYEES, INDEPENDENT CONTRACTORS AND EMPLOYEE CANDIDATES (U.S. CLS. 100, 101 AND 102).

FIRST USE 9-19-2011; IN COMMERCE 9-22-2011.

THE MARK CONSISTS OF STANDARD CHARACTERS WITHOUT CLAIM TO ANY PARTICULAR FONT, STYLE, SIZE, OR COLOR.

OWNER OF U.S. REG. NOS. 2,298,901, 2,388,768, AND OTHERS.

FOR APARTMENT, CONDOMINIUM AND REAL ESTATE MANAGEMENT SERVICES; REAL ESTATE BROKERAGE SERVICES (U.S. CLS. 100, 101 AND 102).

FIRST USE 1-10-2012; IN COMMERCE 1-10-2012.

CLASS 36—(Continued).

4,118,896. THE PRUDENTIAL INSURANCE COMPANY OF AMERICA, NEWARK, NJ. SN 77-656,478. PUB. 10-20-2009, FILED 1-26-2009.

MY LEGACY

THE MARK CONSISTS OF STANDARD CHARACTERS WITHOUT CLAIM TO ANY PARTICULAR FONT, STYLE, SIZE, OR COLOR.

FOR LIFE INSURANCE UNDERWRITING AND POLICY ACQUISITION SERVICES RENDERED ENTIRELY VIA THE INTERNET, WITHOUT IMPOSING REQUIREMENT OF MEDICAL EXAMINATION, PROVIDING BENEFIT OF COVERAGE DECISION AND ISSUANCE OF POLICY VIA THE INTERNET (U.S. CLS. 100, 101 AND 102).

FIRST USE 3-0-2010; IN COMMERCE 3-0-2010.

4,118,956. LAURA TWIRLS SUICIDE AWARENESS FOUNDATION, WONDER LAKE, IL. SN 77-863,057. PUB. 4-20-2010, FILED 11-2-2009.

LAURA TWIRLS

THE MARK CONSISTS OF STANDARD CHARACTERS WITHOUT CLAIM TO ANY PARTICULAR FONT, STYLE, SIZE, OR COLOR.

THE NAME(S), PORTRAIT(S), AND/OR SIGNATURE(S) SHOWN IN THE MARK DOES NOT IDENTIFY A PARTICULAR LIVING INDIVIDUAL.

FOR CHARITABLE FUNDRAISING SERVICES (U.S. CLS. 100, 101 AND 102).

FIRST USE 9-9-2011; IN COMMERCE 9-9-2011.

4,119,006. RWN MANAGEMENT LLC, NEW YORK, NY. SN 77-920,019. PUB. 6-15-2010, FILED 1-26-2010.

RWN MANAGEMENT LLC

THE MARK CONSISTS OF STANDARD CHARACTERS WITHOUT CLAIM TO ANY PARTICULAR FONT, STYLE, SIZE, OR COLOR.

NO CLAIM IS MADE TO THE EXCLUSIVE RIGHT TO USE "MANAGEMENT LLC", APART FROM THE MARK AS SHOWN.

FOR FINANCIAL SERVICES, NAMELY, FUND MANAGEMENT AND INVESTMENT ADVISORY SERVICES (U.S. CLS. 100, 101 AND 102).

FIRST USE 11-9-2011; IN COMMERCE 11-9-2011.

CLASS 36—(Continued).

4,119,020. T-GATE, LLC, SCHAUMBURG, IL. SN 77-928,957. PUB. 1-4-2011, FILED 2-5-2010.

TGATE SECURELINK

THE MARK CONSISTS OF STANDARD CHARACTERS WITHOUT CLAIM TO ANY PARTICULAR FONT, STYLE, SIZE, OR COLOR.

FOR CREDIT CARD AND BANK CARD TRANSACTION PROCESSING SERVICES; DEBIT CARD AND CHECK VERIFICATION, CASHING AND PAYMENT PROCESSING SERVICES; GIFT CARD AND LOYALTY PAYMENT PROCESSING SERVICES; ELECTRONIC FUNDS TRANSFER (U.S. CLS. 100, 101 AND 102).

FIRST USE 8-9-2011; IN COMMERCE 8-9-2011.

4,119,022. D CUBED GROUP LLC, NEW YORK, NY. SN 77-929,710. PUB. 1-25-2011, FILED 2-5-2010.

PRUDENT PRIVATE EQUITY

THE MARK CONSISTS OF STANDARD CHARACTERS WITHOUT CLAIM TO ANY PARTICULAR FONT, STYLE, SIZE, OR COLOR.

NO CLAIM IS MADE TO THE EXCLUSIVE RIGHT TO USE "PRIVATE EQUITY", APART FROM THE MARK AS SHOWN.

FOR FINANCIAL AND INVESTMENT SERVICES, NAMELY, INVESTING, PROVIDING INVESTMENT ADVICE AND INVESTMENT SERVICES, PRIVATE EQUITY INVESTING AND MANAGEMENT SERVICES, FINANCIAL ASSET AND INVESTMENT MANAGEMENT SERVICES, AND INVESTMENT BANKING SERVICES (U.S. CLS. 100, 101 AND 102).

FIRST USE 1-0-2011; IN COMMERCE 7-0-2011.

CLASS 36—(Continued).

4,119,023. D CUBED GROUP LLC, NEW YORK, NY. SN 77-929,712. PUB. 1-4-2011, FILED 2-5-2010.

ENGAGED PARTNERSHIP

THE MARK CONSISTS OF STANDARD CHARACTERS WITHOUT CLAIM TO ANY PARTICULAR FONT, STYLE, SIZE, OR COLOR.

FOR FINANCIAL AND INVESTMENT SERVICES, NAMELY, INVESTING, PROVIDING INVESTMENT ADVICE AND INVESTMENT SERVICES, PRIVATE EQUITY INVESTING AND MANAGEMENT SERVICES, FINANCIAL ASSET AND INVESTMENT MANAGEMENT SERVICES, AND INVESTMENT BANKING SERVICES (U.S. CLS. 100, 101 AND 102).

FIRST USE 1-0-2011; IN COMMERCE 7-0-2011.

4,119,024. D CUBED GROUP LLC, NEW YORK, NY. SN 77-929,713. PUB. 1-25-2011, FILED 2-6-2010.

MATRIX RESOURCES

THE MARK CONSISTS OF STANDARD CHARACTERS WITHOUT CLAIM TO ANY PARTICULAR FONT, STYLE, SIZE, OR COLOR.

NO CLAIM IS MADE TO THE EXCLUSIVE RIGHT TO USE "RESOURCES", APART FROM THE MARK AS SHOWN.

FOR FINANCIAL AND INVESTMENT SERVICES, NAMELY, INVESTING, PROVIDING INVESTMENT ADVICE AND INVESTMENT SERVICES, PRIVATE EQUITY INVESTING AND MANAGEMENT SERVICES, FINANCIAL ASSET AND INVESTMENT MANAGEMENT SERVICES, AND INVESTMENT BANKING SERVICES (U.S. CLS. 100, 101 AND 102).

FIRST USE 1-0-2011; IN COMMERCE 7-0-2011.

4,119,025. D CUBED GROUP LLC, NEW YORK, NY. SN 77-929,717. PUB. 1-4-2011, FILED 2-6-2010.

INVESTOR OF CHOICE

THE MARK CONSISTS OF STANDARD CHARACTERS WITHOUT CLAIM TO ANY PARTICULAR FONT, STYLE, SIZE, OR COLOR.

CLASS 36—(Continued).

NO CLAIM IS MADE TO THE EXCLUSIVE RIGHT TO USE "INVESTOR", APART FROM THE MARK AS SHOWN.

FOR FINANCIAL AND INVESTMENT SERVICES, NAMELY, INVESTING, PROVIDING INVESTMENT ADVICE AND INVESTMENT SERVICES, PRIVATE EQUITY INVESTING AND MANAGEMENT SERVICES, FINANCIAL ASSET AND INVESTMENT MANAGEMENT SERVICES, AND INVESTMENT BANKING SERVICES (U.S. CLS. 100, 101 AND 102).

FIRST USE 1-0-2011; IN COMMERCE 7-0-2011.

4,119,256. FAMILY MOTOR COACH ASSOCIATION, INC., CINCINNATI, OH. SN 85-125,933. PUB. 5-17-2011, FILED 9-9-2010.

FMCA REWARDS

THE MARK CONSISTS OF STANDARD CHARACTERS WITHOUT CLAIM TO ANY PARTICULAR FONT, STYLE, SIZE, OR COLOR.

NO CLAIM IS MADE TO THE EXCLUSIVE RIGHT TO USE "REWARDS", APART FROM THE MARK AS SHOWN.

FOR INSURANCE SERVICES FOR MOTORCOACH OWNERS, NAMELY, PROVISION OF AN ACCIDENT INSURANCE PLAN (U.S. CLS. 100, 101 AND 102).

FIRST USE 11-20-2010; IN COMMERCE 11-20-2010.

4,119,310. ASSURANT, INC., NEW YORK, NY. SN 85-161,792. PUB. 5-17-2011, FILED 10-26-2010.

CRADLE

THE MARK CONSISTS OF STANDARD CHARACTERS WITHOUT CLAIM TO ANY PARTICULAR FONT, STYLE, SIZE, OR COLOR.

FOR INSURANCE SERVICES, NAMELY, UNDERWRITING AND ADMINISTRATION OF INSURANCE THAT PROVIDES A BENEFIT EQUAL TO THE PAYMENT OBLIGATIONS OF THE INSURED FOR CREDIT CARDS, INSTALLMENT LOANS, HOME RELATED LOANS, AUTO LOANS AND PERSONAL LOANS IN THE EVENT OF ACCIDENTAL DEATH, ALL OTHER CAUSES OF DEATH, DISABILITY, UNEMPLOYMENT AND HOSPITALIZATION (U.S. CLS. 100, 101 AND 102).

FIRST USE 5-0-2011; IN COMMERCE 5-0-2011.

CLASS 36—(Continued).

4,119,311. ASSURANT, INC., NEW YORK, NY. SN 85-161,795.
PUB. 5-17-2011, FILED 10-26-2010.

CLASS 36—(Continued).

4,119,334. 3TRACE, DBA TRACE3, IRVINE, CA. SN 85-180,516. PUB. 6-21-2011, FILED 11-18-2010.

PRESERVE YOUR EVERYDAY

THE MARK CONSISTS OF STANDARD CHARACTERS WITHOUT CLAIM TO ANY PARTICULAR FONT, STYLE, SIZE, OR COLOR.

FOR INSURANCE SERVICES, NAMELY, UNDERWRITING AND ADMINISTRATION OF INSURANCE THAT PROVIDES A BENEFIT EQUAL TO THE PAYMENT OBLIGATIONS OF THE INSURED FOR CREDIT CARDS, INSTALLMENT LOANS, HOME RELATED LOANS, AUTO LOANS AND PERSONAL LOANS IN THE EVENT OF ACCIDENTAL DEATH, ALL OTHER CAUSES OF DEATH, DISABILITY, UNEMPLOYMENT AND HOSPITALIZATION (U.S. CLS. 100, 101 AND 102).
FIRST USE 5-0-2011; IN COMMERCE 5-0-2011.

INSTANTSCALE

THE MARK CONSISTS OF STANDARD CHARACTERS WITHOUT CLAIM TO ANY PARTICULAR FONT, STYLE, SIZE, OR COLOR.

FOR FINANCIAL INVESTMENT IN THE FIELD OF TECHNOLOGY (U.S. CLS. 100, 101 AND 102).
FIRST USE 10-1-2011; IN COMMERCE 10-1-2011.

4,119,320. CROWN PAWNBROKERS INC, WASHINGTON, DC. SN 85-173,924. PUB. 3-29-2011, FILED 11-10-2010.



NO CLAIM IS MADE TO THE EXCLUSIVE RIGHT TO USE "PAWNBROKERS" AND "EST 1935", APART FROM THE MARK AS SHOWN.

THE MARK CONSISTS OF A CROWN WITH THE STYLIZED TEXT "CROWN" ON IT. BELOW THE DESIGN ELEMENT IS THE STYLIZED TEXT "PAWNBROKERS" ABOVE "EST 1935". ORNAMENTAL SWIRL DESIGNS APPEAR ON EITHER SIDE OF THE TEXT "EST 1935".

FOR PAWN BROKERAGE; PAWN SHOPS (U.S. CLS. 100, 101 AND 102).
FIRST USE 1-1-2011; IN COMMERCE 1-30-2011.

4,119,336. ANDREW MITCHELL & COMPANY, LLC, FORMERLY CONCIERGE REALTY PARTNERS, LLC, CONCORD, MA. SN 85-182,468. PUB. 4-26-2011, FILED 11-22-2010.

ANDREW MITCHELL

THE MARK CONSISTS OF STANDARD CHARACTERS WITHOUT CLAIM TO ANY PARTICULAR FONT, STYLE, SIZE, OR COLOR.

THE NAME "ANDREW MITCHELL" DOES NOT IDENTIFY A LIVING INDIVIDUAL.

FOR COMMERCIAL AND RESIDENTIAL REAL ESTATE AGENCY SERVICES; PROVIDING REAL ESTATE LISTINGS AND REAL ESTATE INFORMATION VIA THE INTERNET; REAL ESTATE AGENCIES; REAL ESTATE BROKERAGE; REAL ESTATE SERVICES, NAMELY, RENTAL, BROKERAGE, LEASING AND MANAGEMENT OF COMMERCIAL PROPERTY, OFFICES AND OFFICE SPACE (U.S. CLS. 100, 101 AND 102).

FIRST USE 11-1-2010; IN COMMERCE 12-1-2010.

CLASS 36—(Continued).

4,119,337. ANDREW MITCHELL & COMPANY, LLC, FORMERLY CONCIERGE REALTY PARTNERS, LLC, CONCORD, MA. SN 85-182,509. PUB. 4-26-2011, FILED 11-22-2010.



NO CLAIM IS MADE TO THE EXCLUSIVE RIGHT TO USE "& CO", APART FROM THE MARK AS SHOWN.

THE COLOR(S) RED, WHITE, TAN IS/ARE CLAIMED AS A FEATURE OF THE MARK.

THE MARK CONSISTS OF A RED CIRCLE WITH AN INNER WHITE ROUND RING SURROUNDING A DESIGN OF INTERWOVEN TAN LETTERS "A" AND "M", WITH TAN "& CO" BENEATH THE "A" AND "M".

FOR COMMERCIAL AND RESIDENTIAL REAL ESTATE AGENCY SERVICES; PROVIDING REAL ESTATE LISTINGS AND REAL ESTATE INFORMATION VIA THE INTERNET; REAL ESTATE AGENCIES; REAL ESTATE BROKERAGE; REAL ESTATE SERVICES, NAMELY, RENTAL, BROKERAGE, LEASING AND MANAGEMENT OF COMMERCIAL PROPERTY, OFFICES AND OFFICE SPACE (U.S. CLS. 100, 101 AND 102).

FIRST USE 11-1-2010; IN COMMERCE 12-1-2010.

4,119,374. WOLF & WOLF SEEDS, INC., ORLANDO, FL. SN 85-194,981. PUB. 4-26-2011, FILED 12-10-2010.

DOSUS

THE MARK CONSISTS OF STANDARD CHARACTERS WITHOUT CLAIM TO ANY PARTICULAR FONT, STYLE, SIZE, OR COLOR.

FOR FUNDRAISING SERVICES, NAMELY, RAISING FUNDS THROUGH DONATIONS AND THE SALE OF IMPROVED TROPICAL AND SUBTROPICAL FORAGE GRASS AND LEGUME SEEDS TO AID DEVELOPMENT, AND AGRICULTURAL ORGANIZATIONS IN DEVELOPING COUNTRIES BY PROVIDING SUSTAINABLE IMPROVEMENT OF NUTRITIONAL INTAKE TO LIVESTOCK IN THE FORM OF NON-GMO FORAGE PLANTS AND SEEDS (U.S. CLS. 100, 101 AND 102).

FIRST USE 3-21-2011; IN COMMERCE 3-21-2011.

CLASS 36—(Continued).

4,119,405. DOUBLEWIDE PARTNERS I, LLC, RICHARDSON, TX. SN 85-200,975. PUB. 5-3-2011, FILED 12-17-2010.

BLINKPAY

THE MARK CONSISTS OF STANDARD CHARACTERS WITHOUT CLAIM TO ANY PARTICULAR FONT, STYLE, SIZE, OR COLOR.

FOR BILL PAYMENT SERVICES; BILL PAYMENT SERVICES PROVIDED THROUGH A WEBSITE; CREDIT CARD AND PAYMENT CARD SERVICES; CREDIT CARD PAYMENT PROCESSING SERVICES; ELECTRONIC PAYMENT, NAMELY, ELECTRONIC PROCESSING AND TRANSMISSION OF BILL PAYMENT DATA; FINANCIAL TRANSACTION SERVICES, NAMELY, PROVIDING SECURE COMMERCIAL TRANSACTIONS AND PAYMENT OPTIONS; PAYMENT PROCESSING SERVICES, NAMELY, CREDIT CARD AND DEBIT CARD TRANSACTION PROCESSING SERVICES; PROVIDING ELECTRONIC PROCESSING OF CREDIT CARD TRANSACTIONS AND ELECTRONIC PAYMENTS VIA A GLOBAL COMPUTER NETWORK; PROVIDING ELECTRONIC PROCESSING OF ELECTRONIC FUNDS TRANSFER, ACH, CREDIT CARD, DEBIT CARD, ELECTRONIC CHECK AND ELECTRONIC PAYMENTS (U.S. CLS. 100, 101 AND 102).

FIRST USE 2-9-2011; IN COMMERCE 2-9-2011.

4,119,424. NIELSEN, JOHN M, SAN FRANCISCO, CA. SN 85-204,540. PUB. 5-3-2011, FILED 12-22-2010.

BIZ RISK

THE MARK CONSISTS OF STANDARD CHARACTERS WITHOUT CLAIM TO ANY PARTICULAR FONT, STYLE, SIZE, OR COLOR.

NO CLAIM IS MADE TO THE EXCLUSIVE RIGHT TO USE "BIZ", APART FROM THE MARK AS SHOWN.

FOR INSURANCE AGENCIES IN THE FIELD OF HEALTH CARE, EMPLOYEE BENEFITS, PROPERTY, CASUALTY INSURANCE, ERRORS AND OMISSIONS, DIRECTORS AND OFFICERS COVERAGE, PROPERTY, CASUALTY, COMMERCIAL AUTOMOBILE COVERAGE, CRIME COVERAGE, AVIATION INSURANCE, ENVIRONMENTAL INSURANCE, ACCIDENT AND HEALTH, KIDNAP AND RANSOM INSURANCE, DISABILITY INSURANCE, BUSINESS INTERRUPTION INSURANCE, INLAND MARINE INSURANCE, OCEAN CARGO INSURANCE; INSURANCE BROKERAGE IN THE FIELD OF HEALTH CARE, DENTAL INSURANCE, EMPLOYEE BENEFITS, PROPERTY, CASUALTY INSURANCE, ERRORS AND OMISSIONS, DIRECTORS AND OFFICERS COVERAGE, PROPERTY, CASUALTY, COMMERCIAL AUTOMOBILE COVERAGE, CRIME COVERAGE, AVIATION INSURANCE, ENVIRONMENTAL INSURANCE, ACCIDENT AND HEALTH, KIDNAP AND RANSOM INSURANCE, DISABILITY INSURANCE, BUSINESS INTERRUPTION INSURANCE, INLAND MARINE INSURANCE, OCEAN CARGO INSURANCE (U.S. CLS. 100, 101 AND 102).

FIRST USE 4-1-2011; IN COMMERCE 8-1-2011.

CLASS 36—(Continued).

4,119,439. MARTENS, RUSSELL A., WELLINGTON, FL. AND MARTENS, PAMELA K., WESTMORELAND, NH. SN 85-208,786. PUB. 5-31-2011, FILED 1-1-2011.

Wall Street On Parade

THE MARK CONSISTS OF STANDARD CHARACTERS WITHOUT CLAIM TO ANY PARTICULAR FONT, STYLE, SIZE, OR COLOR.

NO CLAIM IS MADE TO THE EXCLUSIVE RIGHT TO USE "WALL STREET", APART FROM THE MARK AS SHOWN.

FOR PROVIDING ON-LINE NEWS IN THE FIELD OF FINANCE (U.S. CLS. 100, 101 AND 102).

FIRST USE 12-31-2010; IN COMMERCE 11-19-2011.

4,119,441. D CUBED GROUP LLC, NEW YORK, NY. SN 85-209,485. PUB. 7-12-2011, FILED 1-3-2011.

NOT ALL MONEY IS GREEN

THE MARK CONSISTS OF STANDARD CHARACTERS WITHOUT CLAIM TO ANY PARTICULAR FONT, STYLE, SIZE, OR COLOR.

FOR FINANCIAL AND INVESTMENT SERVICES, NAMELY, CAPITAL INVESTMENT SERVICES, PROVIDING INVESTMENT ADVICE, PRIVATE EQUITY FUND INVESTMENT SERVICES AND PRIVATE EQUITY FUND INVESTMENT MANAGEMENT SERVICES, FINANCIAL ASSET AND INVESTMENT MANAGEMENT SERVICES, AND INVESTMENT BANKING SERVICES (U.S. CLS. 100, 101 AND 102).

FIRST USE 1-0-2011; IN COMMERCE 7-0-2011.

4,119,444. CDOC, INC., CARMEL, IN. SN 85-209,945. PUB. 5-24-2011, FILED 1-4-2011.

WASHINGTON NATIONAL CRITICAL SOLUTIONS

THE MARK CONSISTS OF STANDARD CHARACTERS WITHOUT CLAIM TO ANY PARTICULAR FONT, STYLE, SIZE, OR COLOR.

OWNER OF U.S. REG. NOS. 3,263,912, 3,263,913, AND 3,263,914.

NO CLAIM IS MADE TO THE EXCLUSIVE RIGHT TO USE "CRITICAL SOLUTIONS", APART FROM THE MARK AS SHOWN.

CLASS 36—(Continued).

SEC. 2(F) AS TO "WASHINGTON NATIONAL".

FOR INSURANCE SERVICES, NAMELY, UNDERWRITING SUPPLEMENTAL HEALTH INSURANCE IN THE FIELD OF CRITICAL ILLNESS INSURANCE (U.S. CLS. 100, 101 AND 102).

FIRST USE 9-1-2011; IN COMMERCE 9-1-2011.

4,119,450. METROPOLITAN LIFE INSURANCE COMPANY, NEW YORK, NY. SN 85-211,968. PUB. 5-24-2011, FILED 1-6-2011.

METLIFE RAPID eUNDERWRITING

THE MARK CONSISTS OF STANDARD CHARACTERS WITHOUT CLAIM TO ANY PARTICULAR FONT, STYLE, SIZE, OR COLOR.

OWNER OF U.S. REG. NOS. 1,415,273, 3,799,545, AND OTHERS.

NO CLAIM IS MADE TO THE EXCLUSIVE RIGHT TO USE "RAPID eUNDERWRITING", APART FROM THE MARK AS SHOWN.

FOR INSURANCE SERVICES, NAMELY, UNDERWRITING, ISSUING AND ADMINISTRATION OF LIFE INSURANCE (U.S. CLS. 100, 101 AND 102).

FIRST USE 10-29-2010; IN COMMERCE 10-29-2010.

4,119,482. MB FIELD SERVICES, INC., ATLANTA, GA. SN 85-221,434. PUB. 5-3-2011, FILED 1-19-2011.

INSPECT

THE MARK CONSISTS OF STANDARD CHARACTERS WITHOUT CLAIM TO ANY PARTICULAR FONT, STYLE, SIZE, OR COLOR.

FOR REAL ESTATE SERVICES, NAMELY, PROPERTY MANAGEMENT SERVICES FOR LENDERS OF REPOSSESSED PROPERTIES (U.S. CLS. 100, 101 AND 102).

FIRST USE 12-15-2011; IN COMMERCE 12-15-2011.

CLASS 36—(Continued).

4,119,493. MB FIELD SERVICES, INC., ATLANTA, GA. SN 85-222,564. PUB. 5-3-2011, FILED 1-20-2011.

RESTORE

THE MARK CONSISTS OF STANDARD CHARACTERS WITHOUT CLAIM TO ANY PARTICULAR FONT, STYLE, SIZE, OR COLOR.

FOR REAL ESTATE SERVICES, NAMELY, PROPERTY MANAGEMENT SERVICES FOR LENDERS OF REPOSESSED PROPERTIES (U.S. CLS. 100, 101 AND 102). FIRST USE 12-15-2011; IN COMMERCE 12-15-2011.



4,119,500. GALIAM HOLDINGS, LLC, SAN FRANCISCO, CA. SN 85-225,216. PUB. 5-31-2011, FILED 1-25-2011.

Galiam

THE MARK CONSISTS OF STANDARD CHARACTERS WITHOUT CLAIM TO ANY PARTICULAR FONT, STYLE, SIZE, OR COLOR.

FOR INVESTMENT ADVISORY AND MANAGEMENT SERVICES (U.S. CLS. 100, 101 AND 102). FIRST USE 4-1-2011; IN COMMERCE 4-1-2011.



4,119,518. PRIVATE WEALTH GROUP, LLC, TAMPA, FL. SN 85-230,317. PUB. 6-28-2011, FILED 1-31-2011.

INTELLIGENT EQUITY

THE MARK CONSISTS OF STANDARD CHARACTERS WITHOUT CLAIM TO ANY PARTICULAR FONT, STYLE, SIZE, OR COLOR.

NO CLAIM IS MADE TO THE EXCLUSIVE RIGHT TO USE "EQUITY", APART FROM THE MARK AS SHOWN.

FOR FINANCIAL SERVICES, NAMELY, CONSULTING SERVICES IN THE FIELD OF FINANCES (U.S. CLS. 100, 101 AND 102). FIRST USE 1-5-2011; IN COMMERCE 1-5-2011.

CLASS 36—(Continued).

4,119,550. EVEREST CAPITAL LLC, MIAMI, FL. SN 85-244,775. PUB. 7-12-2011, FILED 2-17-2011.

EVCAP

THE MARK CONSISTS OF STANDARD CHARACTERS WITHOUT CLAIM TO ANY PARTICULAR FONT, STYLE, SIZE, OR COLOR.

OWNER OF U.S. REG. NOS. 3,118,598, 3,118,599, AND 3,291,250.

FOR RENDERING INVESTMENT MANAGEMENT SERVICES TO PRIVATE ENTITIES AND ACCOUNTS (U.S. CLS. 100, 101 AND 102).

FIRST USE 2-28-2011; IN COMMERCE 2-28-2011.



4,119,552. UNITED SERVICES AUTOMOBILE ASSOCIATION, SAN ANTONIO, TX. SN 85-245,356. PUB. 5-24-2011, FILED 2-17-2011.

BEGIN YOUR LEGACY

THE MARK CONSISTS OF STANDARD CHARACTERS WITHOUT CLAIM TO ANY PARTICULAR FONT, STYLE, SIZE, OR COLOR.

FOR FINANCIAL SERVICES, NAMELY, BANKING, CREDIT AND DEBIT CARD, AND LOAN SERVICES; TRUST AND ASSET MANAGEMENT SERVICES; MORTGAGE BANKING AND LENDING SERVICES; PAYMENT OF THIRD PARTY BILLS SERVICES; FINANCIAL AND INVESTMENT SERVICES, NAMELY, MANAGEMENT AND BROKERAGE IN THE FIELDS OF STOCKS, BONDS, OPTIONS, COMMODITIES, MUTUAL FUNDS, REAL ESTATE, FUTURES AND OTHER SECURITIES, AND THE INVESTMENT OF FUNDS OF OTHERS; FINANCIAL AND INVESTMENT INFORMATION, ADVICE, ANALYSIS, CONSULTATION, RESEARCH, PLANNING AND MANAGEMENT SERVICES; INSURANCE SERVICES, NAMELY, UNDERWRITING, ISSUING AND ADMINISTRATION OF ALL TYPES OF INSURANCES; INSURANCE ADVICE, ANALYSIS, CONSULTATION, RESEARCH, PLANNING AND MANAGEMENT SERVICES; INSURANCE AGENCY AND BROKERAGE SERVICES; AND REAL ESTATE CONSULTATION AND MANAGEMENT SERVICES (U.S. CLS. 100, 101 AND 102).

FIRST USE 3-14-2011; IN COMMERCE 3-14-2011.

CLASS 36—(Continued).

4,119,597. THE TRAVELERS INDEMNITY COMPANY, HARTFORD, CT. SN 85-269,410. PUB. 5-31-2011, FILED 3-17-2011.

CYBERFIRST ESSENTIALS

THE MARK CONSISTS OF STANDARD CHARACTERS WITHOUT CLAIM TO ANY PARTICULAR FONT, STYLE, SIZE, OR COLOR.

OWNER OF U.S. REG. NO. 3,719,590.
FOR PROPERTY AND CASUALTY INSURANCE UNDERWRITING SERVICES (U.S. CLS. 100, 101 AND 102).
FIRST USE 10-14-2011; IN COMMERCE 10-14-2011.

4,119,652. MB FIELD SERVICES, INC., ATLANTA, GA. SN 85-302,122. PUB. 9-13-2011, FILED 4-22-2011.

VALUE

THE MARK CONSISTS OF STANDARD CHARACTERS WITHOUT CLAIM TO ANY PARTICULAR FONT, STYLE, SIZE, OR COLOR.

FOR REAL ESTATE SERVICES, NAMELY, PROPERTY MANAGEMENT SERVICES FOR LENDERS OF REPOSSESSED PROPERTIES (U.S. CLS. 100, 101 AND 102).
FIRST USE 12-15-2011; IN COMMERCE 12-15-2011.

4,119,683. GEORGIA'S OWN CREDIT UNION, ATLANTA, GA. SN 85-326,017. PUB. 10-25-2011, FILED 5-20-2011.

GEORGIA'S OWN RESOLUTION CHECKING

THE MARK CONSISTS OF STANDARD CHARACTERS WITHOUT CLAIM TO ANY PARTICULAR FONT, STYLE, SIZE, OR COLOR.

OWNER OF U.S. REG. NOS. 3,499,492 AND 3,505,746.
NO CLAIM IS MADE TO THE EXCLUSIVE RIGHT TO USE "GEORGIA'S" AND "CHECKING", APART FROM THE MARK AS SHOWN.
FOR CHECKING ACCOUNT SERVICES (U.S. CLS. 100, 101 AND 102).
FIRST USE 7-0-2011; IN COMMERCE 7-0-2011.

CLASS 37—CONSTRUCTION AND REPAIR**CLASS 37—(Continued).**

4,118,829. NIITEK INC., DULLES, VA. SN 77-464,260. PUB. 9-30-2008, FILED 5-2-2008.

NIITEK

THE MARK CONSISTS OF STANDARD CHARACTERS WITHOUT CLAIM TO ANY PARTICULAR FONT, STYLE, SIZE, OR COLOR.

FOR INSTALLATION, MAINTENANCE AND REPAIR OF METAL DETECTORS; INSTALLATION, MAINTENANCE AND REPAIR OF GROUND PENETRATING RADAR SENSORS; INSTALLATION, MAINTENANCE AND REPAIR OF NON-INTRUSIVE SENSORS; INSTALLATION, MAINTENANCE AND REPAIR OF METAL DETECTORS, GROUND PENETRATING RADARS AND SYSTEMS, IMAGING AND VISUALIZATION SYSTEMS FOR DETECTION OF OBJECTS AND/OR GEOLOGICAL FEATURES; INSTALLATION, MAINTENANCE AND REPAIR OF DETECTORS, IMAGING AND/OR VISUALIZATION SYSTEMS, NAMELY, SENSORS AND/OR METAL DETECTORS FOR LOCATING AND/OR IMAGING OBJECTS, GEOLOGICAL FEATURES, BURIED OBJECTS, HIDDEN OBJECTS, LAND MINES, EXPLOSIVE HAZARDS, AND/OR UNDERGROUND ANOMALIES; INSTALLATION, MAINTENANCE AND REPAIR OF VEHICLE MOUNTED MINE AND EXPLOSIVES DETECTION SYSTEMS; INSTALLATION, MAINTENANCE AND REPAIR OF VEHICLE MOUNTED DETECTORS, IMAGING AND/OR VISUALIZATION SYSTEMS, NAMELY, SENSORS AND/OR METAL DETECTORS FOR LOCATING AND/OR IMAGING OBJECTS, GEOLOGICAL FEATURES, BURIED OBJECTS, HIDDEN OBJECTS, LAND MINES, EXPLOSIVE HAZARDS, AND/OR UNDERGROUND ANOMALIES; AND INSTALLATION, MAINTENANCE AND REPAIR OF MINE AND EXPLOSIVES DETECTION SYSTEMS (U.S. CLS. 100, 103 AND 106).

FIRST USE 12-31-2000; IN COMMERCE 12-31-2000.

4,118,839. MASCO FRAMING CORP., CHANDLER, AZ. SN 77-481,267. PUB. 4-28-2009, FILED 5-22-2008.

PRECISION FRAMING SYSTEMS

THE MARK CONSISTS OF STANDARD CHARACTERS WITHOUT CLAIM TO ANY PARTICULAR FONT, STYLE, SIZE, OR COLOR.

NO CLAIM IS MADE TO THE EXCLUSIVE RIGHT TO USE "FRAMING SYSTEMS", APART FROM THE MARK AS SHOWN.
FOR BUILDING CONSTRUCTION SERVICES (U.S. CLS. 100, 103 AND 106).
FIRST USE 6-0-2009; IN COMMERCE 6-0-2009.

CLASS 37—(Continued).

4,118,964. ALABAMA PROFESSIONAL SERVICES, INC., IRONDALE, AL. SN 77-872,518. PUB. 3-1-2011, FILED 11-13-2009.



NO CLAIM IS MADE TO THE EXCLUSIVE RIGHT TO USE "ALABAMA PROFESSIONAL SERVICES" AND "PEST AND TERMITE CONTROL", APART FROM THE MARK AS SHOWN.

THE COLOR(S) BLACK, WHITE, RED, GRAY AND YELLOW IS/ARE CLAIMED AS A FEATURE OF THE MARK.

THE MARK CONSISTS OF A SHIELD WITH BACKGROUND RED, HOUSE WHITE, BUG WITHIN HOUSE RED, MARK TO THE RIGHT OF HOUSE YELLOW, OUTLINED BY BLACK AND GRAY.

FOR PEST CONTROL; PEST CONTROL AND EXTERMINATION OTHER THAN FOR AGRICULTURAL PURPOSES; TERMITES AND PEST CONTROL (U.S. CLS. 100, 103 AND 106).

FIRST USE 2-1-2010; IN COMMERCE 2-1-2010.

4,119,085. DUCE CONSTRUCTION CORPORATION, NEW YORK, NY. SN 85-024,172. PUB. 1-18-2011, FILED 4-27-2010.



NO CLAIM IS MADE TO THE EXCLUSIVE RIGHT TO USE "PROPERTY MAINTENANCE MANAGEMENT", APART FROM THE MARK AS SHOWN.

THE MARK CONSISTS OF THE STYLIZED LETTERS "P" "M" AND "M" WITH A LEAF DESIGN BETWEEN THE LETTERS AND THE WORDS "PROPERTY MAINTENANCE MANAGEMENT" APPEARING BELOW THE LETTERS.

FOR REAL ESTATE PROPERTY MAINTENANCE SERVICES, RENOVATION OF PROPERTY AND BUILDING RESTORATION (U.S. CLS. 100, 103 AND 106).

FIRST USE 1-7-2011; IN COMMERCE 9-15-2011.

CLASS 37—(Continued).

4,119,221. COMFORT SYSTEMS USA, INC., HOUSTON, TX. SN 85-102,965. PUB. 7-12-2011, FILED 8-9-2010.

TRUEBIM

THE MARK CONSISTS OF STANDARD CHARACTERS WITHOUT CLAIM TO ANY PARTICULAR FONT, STYLE, SIZE, OR COLOR.

FOR PROVIDING AN ON-LINE COMPUTER DATABASE FEATURING INFORMATION ON DEVELOPMENT OF PLANNED OR UNDER-CONSTRUCTION BUILDINGS FOR OTHERS (U.S. CLS. 100, 103 AND 106). FIRST USE 4-21-2010; IN COMMERCE 4-21-2010.

4,119,474. HARVARD BUILDING SERVICES, INC., NEW YORK, NY. SN 85-218,118. PUB. 5-17-2011, FILED 1-14-2011.

CIMETICS

THE MARK CONSISTS OF STANDARD CHARACTERS WITHOUT CLAIM TO ANY PARTICULAR FONT, STYLE, SIZE, OR COLOR.

FOR PEST CONTROL SERVICES; PEST CONTROL AND EXTERMINATION SERVICES, OTHER THAN FOR AGRICULTURAL PURPOSES, NAMELY, BED BUG EXTERMINATION AND REMEDIATION SERVICES (U.S. CLS. 100, 103 AND 106).

FIRST USE 2-0-2011; IN COMMERCE 2-0-2011.

4,119,548. PELSTAR, LLC, BROUSSARD, LA. SN 85-244,150. PUB. 6-21-2011, FILED 2-16-2011.

PELSTAR

THE MARK CONSISTS OF STANDARD CHARACTERS WITHOUT CLAIM TO ANY PARTICULAR FONT, STYLE, SIZE, OR COLOR.

FOR MAINTENANCE AND REPAIR SERVICES FOR ROTATING EQUIPMENT, NAMELY, GAS COMPRESSORS, GENERATORS, PUMPS AND POWER UNITS (U.S. CLS. 100, 103 AND 106).

FIRST USE 6-30-2010; IN COMMERCE 3-7-2011.

CLASS 37—(Continued).

4,119,598. ROOFING & RESTORATION SERVICES OF AMERICA, LLC, WAXAHACHIE, TX. SN 85-269,661. PUB. 8-2-2011, FILED 3-17-2011.



THE MARK CONSISTS OF THE LETTERS "RRSA" OVER A SHIELD WHICH CONTAINS 3 STARS ON THE TOP PART OF THE SHIELD AND STRIPES ON THE BOTTOM PART OF THE SHIELD.

FOR ROOFING SERVICES; REPAIR, MAINTENANCE AND INSTALLATION OF ROOFS; ROOFING CONSULTATION (U.S. CLS. 100, 103 AND 106).

FIRST USE 12-0-2010; IN COMMERCE 12-0-2010.

4,119,632. MITCHELL, GAIL R., NEW YORK, NY. SN 85-293,747. PUB. 11-1-2011, FILED 4-13-2011.



NO CLAIM IS MADE TO THE EXCLUSIVE RIGHT TO USE "ILLUMINATION ART", APART FROM THE MARK AS SHOWN.

THE NAME "GAIL R. MITCHELL" IDENTIFIES A LIVING INDIVIDUAL WHOSE CONSENT IS OF RECORD.

THE COLOR(S) BLACK AND GREY IS/ARE CLAIMED AS A FEATURE OF THE MARK.

THE MARK CONSISTS OF A DESIGN OF A STYLIZED BRUSH STROKE WITH THE WORDING "GAIL R. MITCHELL CRYSTAL ILLUMINATION ART". THE WORDING IS IN BLACK AND THE BACKGROUND IS GREY.

FOR INSTALLATION OF CUSTOM DESIGNED WORKS OF ART (U.S. CLS. 100, 103 AND 106). FIRST USE 1-0-2010; IN COMMERCE 1-0-2010.

CLASS 37—(Continued).

4,119,664. SERVICE EXPERTS LLC, RICHARDSON, TX. SN 85-309,711. PUB. 10-11-2011, FILED 5-2-2011.

EXPERT SERVICE GUARANTEED

THE MARK CONSISTS OF STANDARD CHARACTERS WITHOUT CLAIM TO ANY PARTICULAR FONT, STYLE, SIZE, OR COLOR.

NO CLAIM IS MADE TO THE EXCLUSIVE RIGHT TO USE "SERVICE GUARANTEED", APART FROM THE MARK AS SHOWN.

FOR MAINTENANCE, REPAIR, SERVICING AND INSTALLATION SERVICES FOR AIR CONDITIONING, HEATING, AIR PURIFICATION, PLUMBING AND ELECTRICAL EQUIPMENT (U.S. CLS. 100, 103 AND 106). FIRST USE 6-1-2011; IN COMMERCE 6-1-2011.

4,119,665. HAINSWORTH, CRAIG, CORONA, CA. SN 85-310,522. PUB. 10-4-2011, FILED 5-3-2011.



THE MARK CONSISTS OF A STYLIZED LETTER "H" PRESENTED AT AN ANGLED POSITION AND FEATURING POINTED EDGES IN THE UPPER RIGHT AND LOWER LEFT REGIONS SUPERIMPOSED OVER TWO CONCENTRIC CIRCLES.

FOR BUILDING INSPECTION; INSPECTION SERVICES IN THE COURSE OF CONSTRUCTION OF SCHOOLS, HOSPITALS AND BRIDGES; BUILDING CONSTRUCTION OBSERVATION, NAMELY, STATIC INSPECTION, FUNCTIONAL VERIFICATION INSPECTION AND PERFORMANCE VERIFICATION INSPECTION (U.S. CLS. 100, 103 AND 106).

FIRST USE 8-1-2011; IN COMMERCE 8-1-2011.

CLASS 37—(Continued).

4,119,673. NESTORE, ROBERT, DBA DCCS DAYCARE CLEANING SERVICES, MARLTON, NJ. SN 85-317,823. PUB. 10-25-2011, FILED 5-11-2011.



NO CLAIM IS MADE TO THE EXCLUSIVE RIGHT TO USE "DAYCARE CLEANING SERVICES" AND "HEALTHCARE CLEANING FOR SCHOOLS", APART FROM THE MARK AS SHOWN.

THE MARK CONSISTS OF A DEPICTION OF THE WORLD GLOBE, WITH THE LETTERS "DCCS" IMPOSED IN THE PACIFIC OCEAN AREA, ALSO CONTAINING THE WORD "DAYCARE" ABOVE A HORIZONTAL LINE, BELOW WHICH APPEAR THE WORDS "CLEANING SERVICES HEALTHCARE CLEANING FOR SCHOOLS".
FOR JANITORIAL SERVICES (U.S. CLS. 100, 103 AND 106).

FIRST USE 12-1-2011; IN COMMERCE 12-1-2011.

CLASS 38—COMMUNICATION

4,118,899. VOYAGES NORTH AMERICA, INC., NEW YORK, NY. SN 77-688,372. PUB. 5-3-2011, FILED 3-11-2009.

VOYAGE.TV

THE MARK CONSISTS OF STANDARD CHARACTERS WITHOUT CLAIM TO ANY PARTICULAR FONT, STYLE, SIZE, OR COLOR.

OWNER OF U.S. REG. NOS. 3,443,233, 3,915,497, AND 3,915,862.

FOR BROADCASTING OF VIDEO AND AUDIO PROGRAMMING IN THE FIELD OF TRAVEL AND TRAVEL DESTINATIONS OVER TELEVISION, CABLE TELEVISION, VIDEO ON DEMAND, CABLE VISION, THE INTERNET AND OTHER ELECTRONIC COMMUNICATIONS NETWORKS (U.S. CLS. 100, 101 AND 104).
FIRST USE 9-0-2008; IN COMMERCE 9-0-2008.

CLASS 38—(Continued).

4,118,926. PHILADELPHIA 76ERS L.P., PHILADELPHIA, PA. SN 77-766,980. PUB. 11-23-2010, FILED 6-24-2009.



OWNER OF U.S. REG. NOS. 1,152,695, 1,987,275, AND OTHERS.

THE MARK CONSISTS OF A DEPICTION OF A BASKETBALL AND A RING OF STARS WITH THE WORDS "76ERS" SURROUNDED BY A SQUARE BORDER AND ABOVE A BAND WITH THE WORD "PHILADELPHIA".

SEC. 2(F) AS TO "PHILADELPHIA".

FOR AUDIO BROADCASTING; CABLE TELEVISION BROADCASTING; RADIO BROADCASTING; SUBSCRIPTION TELEVISION BROADCASTING; TELEVISION BROADCASTING; VIDEO BROADCASTING; WEBCASTING SERVICES IN THE NATURE OF PROVIDING ON-LINE CHAT ROOMS AND ON-LINE INTERACTIVE CHAT ROOMS WITH GUESTS FOR TRANSMISSION OF MESSAGES AMONG COMPUTER USERS CONCERNING THE FIELD OF BASKETBALL; BROADCASTING PROGRAMS OVER THE INTERNET; PROVIDING ON-LINE ELECTRONIC BULLETIN BOARDS FOR TRANSMISSION OF MESSAGES AMONG COMPUTER USERS CONCERNING THE FIELD OF BASKETBALL; PROVIDING MULTIPLE-USER ACCESS TO A GLOBAL COMPUTER INFORMATION NETWORK FOR THE PURPOSE OF PARTICIPATING IN INTERACTIVE POLLING IN THE FIELD OF BASKETBALL; WIRELESS COMMUNICATIONS SERVICES, NAMELY, TRANSMISSION OF GRAPHICS TO MOBILE TELEPHONES; WIRELESS ELECTRONIC TRANSMISSION OF VOICE SIGNALS, DATA, FACSIMILES, IMAGES AND INFORMATION; WIRELESS BROADBAND COMMUNICATIONS SERVICES (U.S. CLS. 100, 101 AND 104).

FIRST USE 10-6-2009; IN COMMERCE 10-6-2009.

4,118,928. PERCEPTIVE INFORMATICS, INC., WALTHAM, MA. SN 77-773,201. PUB. 11-24-2009, FILED 7-2-2009.

PERCEPTIVE

THE MARK CONSISTS OF STANDARD CHARACTERS WITHOUT CLAIM TO ANY PARTICULAR FONT, STYLE, SIZE, OR COLOR.

CLASS 38—(Continued).

OWNER OF U.S. REG. NOS. 3,142,466 AND 3,190,512.
 FOR COMPUTER SERVICES, NAMELY, PROVISION OF ACCESS TO DATA OR DOCUMENTS STORED ELECTRONICALLY THROUGH INTERACTIVE VOICE AND DATA SYSTEMS FOR USE IN CAPTURING ELECTRONIC DATA AND MANAGING PATIENT ENROLLMENT INFORMATION AND DRUG DEVELOPMENT DATA (U.S. CLS. 100, 101 AND 104).
 FIRST USE 2-28-2002; IN COMMERCE 2-28-2002.

4,118,978. B3 COMMUNICATIONS, LLC, CHICAGO, IL. SN 77-888,804. PUB. 5-24-2011, FILED 12-8-2009.

B³ COMMUNICATIONS

NO CLAIM IS MADE TO THE EXCLUSIVE RIGHT TO USE "COMMUNICATIONS", APART FROM THE MARK AS SHOWN.

THE MARK CONSISTS OF THE LETTER "B" TO THE THIRD POWER NEXT TO THE WORD "COMMUNICATIONS".

FOR TELECOMMUNICATIONS SERVICES, NAMELY, PROVIDING VOICE, DATA AND INTERACTIVE VOICE RESPONSE SYSTEMS VIA CLOUD COMPUTING NETWORKS (U.S. CLS. 100, 101 AND 104).

FIRST USE 1-14-2011; IN COMMERCE 1-14-2011.

4,119,005. C-KO SALES, LLC, MONROE, NY. SN 77-918,913. PUB. 6-8-2010, FILED 1-24-2010.

Oopsie Daisy

THE MARK CONSISTS OF STANDARD CHARACTERS WITHOUT CLAIM TO ANY PARTICULAR FONT, STYLE, SIZE, OR COLOR.

FOR DELIVERY OF PERSONALIZED GREETING CARDS TO OTHERS VIA ELECTRONIC MAIL (U.S. CLS. 100, 101 AND 104).

FIRST USE 6-1-2011; IN COMMERCE 8-15-2011.

CLASS 38—(Continued).

4,119,032. QUORA, INC., PALO ALTO, CA. SN 77-935,142. PUB. 6-29-2010, FILED 2-12-2010.

QUORA

THE MARK CONSISTS OF STANDARD CHARACTERS WITHOUT CLAIM TO ANY PARTICULAR FONT, STYLE, SIZE, OR COLOR.

FOR PROVIDING ON-LINE CHAT ROOMS AND ELECTRONIC BULLETIN BOARDS FOR TRANSMISSION OF MESSAGES AMONG USERS IN THE FIELD OF GENERAL INTEREST (U.S. CLS. 100, 101 AND 104).
 FIRST USE 6-21-2010; IN COMMERCE 6-21-2010.

4,119,107. VOYZZE COMMUNICATIONS INC, FREMONT, CA. SN 85-041,218. PUB. 10-19-2010, FILED 5-18-2010.

UNOVON

THE MARK CONSISTS OF THE STYLIZED TEXT "UNOVON" WITH ONE OF THE "O"'S AS A GLOBE WITH A CABLE AROUND IT AND THE OTHER "O" AS A TELEPHONE.

FOR VOICE OVER IP SERVICES (U.S. CLS. 100, 101 AND 104).

FIRST USE 6-1-2010; IN COMMERCE 7-1-2010.

4,119,242. SARPONG, JUNE, ALTADENA, CA. SN 85-119,219. PUB. 5-3-2011, FILED 8-30-2010.

ROW6.com

THE MARK CONSISTS OF STANDARD CHARACTERS WITHOUT CLAIM TO ANY PARTICULAR FONT, STYLE, SIZE, OR COLOR.

FOR PROVIDING ON-LINE CHAT ROOMS AND ELECTRONIC BULLETIN BOARDS FOR TRANSMISSION OF MESSAGES AMONG USERS IN THE FIELD OF CELEBRITIES, FASHION, FILM, TELEVISION, MUSIC, AND SOCIAL NETWORKING (U.S. CLS. 100, 101 AND 104).

FIRST USE 12-1-2011; IN COMMERCE 12-1-2011.

CLASS 38—(Continued).

4,119,344. TWENTY FIRST CENTURY COMMUNICATIONS, INC., COLUMBUS, OH. SN 85-184,629. PUB. 5-10-2011, FILED 11-24-2010.

CLASS 38—(Continued).

4,119,537. HI-REZ STUDIOS, INC., ALPHARETTA, GA. SN 85-238,332. PUB. 6-14-2011, FILED 2-9-2011.

TFCC UNIVERSAL
COMMUNICATIONS SYSTEM

SMITE

THE MARK CONSISTS OF STANDARD CHARACTERS WITHOUT CLAIM TO ANY PARTICULAR FONT, STYLE, SIZE, OR COLOR.

OWNER OF U.S. REG. NO. 2,978,547.

NO CLAIM IS MADE TO THE EXCLUSIVE RIGHT TO USE "UNIVERSAL COMMUNICATIONS SYSTEM", APART FROM THE MARK AS SHOWN.

FOR HIGH VOLUME INTERNET BASED TELEPHONE COMMUNICATIONS SERVICES FOR PUBLIC UTILITIES, BUSINESSES AND GOVERNMENT AGENCIES AND PROVIDING INTERNET BASED TELEPHONE COMMUNICATIONS SERVICES DESIGNED FOR USE DURING EMERGENCY SITUATIONS, INCLUDING IN-BOUND AND OUTDIAL SERVICES (U.S. CLS. 100, 101 AND 104).

FIRST USE 2-0-2002; IN COMMERCE 2-0-2003.

THE MARK CONSISTS OF STANDARD CHARACTERS WITHOUT CLAIM TO ANY PARTICULAR FONT, STYLE, SIZE, OR COLOR.

FOR PROVIDING ONLINE CHAT ROOMS AND BULLETIN BOARDS FOR TRANSMISSION, RECEPTION AND SHARING OF MESSAGES BY MEANS OF ELECTRONIC OR OPTICAL COMMUNICATIONS NETWORKS, ALL IN THE FIELDS OF COMPUTER GAME ENTERTAINMENT OR AMUSEMENT ACTIVITIES AND MULTI-PLAYER ONLINE COMPUTER GAME COOPERATION AND COMPETITIONS (U.S. CLS. 100, 101 AND 104).

FIRST USE 7-21-2011; IN COMMERCE 7-21-2011.

4,119,580. HI-REZ STUDIOS, INC., ALPHARETTA, GA. SN 85-260,897. PUB. 6-14-2011, FILED 3-8-2011.

4,119,516. BOWLERZONE, LLC, GREENWOOD VILLAGE, CO. SN 85-229,894. PUB. 6-7-2011, FILED 1-31-2011.

TRIBES ASCEND

BOWLERZONE

THE MARK CONSISTS OF STANDARD CHARACTERS WITHOUT CLAIM TO ANY PARTICULAR FONT, STYLE, SIZE, OR COLOR.

FOR PROVIDING ONLINE CHAT ROOMS AND BULLETIN BOARDS FOR TRANSMISSION, RECEPTION AND SHARING OF MESSAGES BY MEANS OF ELECTRONIC OR OPTICAL COMMUNICATIONS NETWORKS, ALL IN THE FIELDS OF COMPUTER GAME ENTERTAINMENT OR AMUSEMENT ACTIVITIES AND MULTI-PLAYER ONLINE COMPUTER GAME COOPERATION AND COMPETITIONS (U.S. CLS. 100, 101 AND 104).

FIRST USE 3-11-2011; IN COMMERCE 3-11-2011.

THE MARK CONSISTS OF STANDARD CHARACTERS WITHOUT CLAIM TO ANY PARTICULAR FONT, STYLE, SIZE, OR COLOR.

FOR PROVIDING ON-LINE CHAT ROOMS FOR SOCIAL NETWORKING (U.S. CLS. 100, 101 AND 104). FIRST USE 3-15-2011; IN COMMERCE 3-15-2011.

CLASS 39—TRANSPORTATION AND STORAGE

CLASS 39—(Continued).

4,119,055. HERBRUCK POULTRY RANCH, INC., SARANAC, MI. SN 77-982,970. PUB. 12-15-2009, FILED 7-23-2009.



THE COLOR(S) BLACK, WHITE AND YELLOW IS/ARE CLAIMED AS A FEATURE OF THE MARK.

THE MARK CONSISTS OF THE FOLLOWING: A SOLID YELLOW CIRCLE INSIDE OF AN OVAL OUTLINED IN BLACK WITH A WHITE INTERIOR RESEMBLING AN EGG AND THE WORDING "HERBRUCK'S" IN BLACK LETTERING ACROSS THE EGG.

FOR SERVICE OF PRIVATE LABEL PACKAGING OF EGGS FOR OTHERS (U.S. CLS. 100 AND 105).

FIRST USE 8-30-2011; IN COMMERCE 8-30-2011.

4,119,089. MINISTRY TRAVEL, LLC, SAYREVILLE, NJ. SN 85-028,434. PUB. 5-3-2011, FILED 5-3-2010.



NO CLAIM IS MADE TO THE EXCLUSIVE RIGHT TO USE "TRAVEL", APART FROM THE MARK AS SHOWN.

THE COLOR(S) PURPLE, WHITE, GOLD, TAN AND BLACK IS/ARE CLAIMED AS A FEATURE OF THE MARK.

THE MARK CONSISTS OF THE WORDING "MINISTRY TRAVEL" IN PURPLE LETTERS WITH WHITE OUTLINING, WITH A COMPASS DESIGN IN BETWEEN THE WORDS "MINISTRY" AND "TRAVEL"; THE COMPASS IS IN THE SHAPE OF A 16-POINT STAR DESIGN WHICH RESEMBLES A CROSS, ALL IN THE COLOR GOLD; THE FACE OF THE COMPASS IS IN THE COLOR TAN, THE NEEDLE OF THE COMPASS IS IN THE COLORS PURPLE AND BLACK, AND THE CENTER OF THE COMPASS IS A DIAMOND DESIGN IN THE COLOR WHITE.

FOR ARRANGING AND COORDINATING TRAVEL ARRANGEMENTS FOR INDIVIDUALS AND GROUPS, NAMELY, DESTINATION STAYS, HONEYMOONS, FAMILY VACATIONS, AND DESTINATION WEDDINGS (U.S. CLS. 100 AND 105).

FIRST USE 6-30-2011; IN COMMERCE 6-30-2011.

CLASS 39—(Continued).

4,119,093. MEADOWS, LEWIS G, DUNKIRK, MD. SN 85-032,661. PUB. 10-12-2010, FILED 5-7-2010.

TaxiCrab

THE MARK CONSISTS OF STANDARD CHARACTERS WITHOUT CLAIM TO ANY PARTICULAR FONT, STYLE, SIZE, OR COLOR.

FOR FOOD DELIVERY (U.S. CLS. 100 AND 105).
FIRST USE 5-1-2011; IN COMMERCE 5-1-2011.

4,119,170. CITYSTASH HOLDINGS, LLC, ARLINGTON, VA. SN 85-073,149. PUB. 1-4-2011, FILED 6-28-2010.

CITYSTASH

THE MARK CONSISTS OF STANDARD CHARACTERS WITHOUT CLAIM TO ANY PARTICULAR FONT, STYLE, SIZE, OR COLOR.

FOR PROVIDING MOVING COMPANY SERVICES AND SELF-STORAGE FACILITIES FOR OTHERS (U.S. CLS. 100 AND 105).

FIRST USE 9-15-2010; IN COMMERCE 9-15-2010.

4,119,227. CITYSTASH HOLDINGS, LLC, ARLINGTON, VA. SN 85-104,940. PUB. 12-14-2010, FILED 8-11-2010.



THE MARK CONSISTS OF A HOUSE DESIGN WITH A SERIES OF VERTICAL LINES TO REPRESENT A BAR CODE, THE DESIGN BEING TO THE LEFT OF THE LITERAL ELEMENT "CITYSTASH".

FOR PROVIDING MOVING COMPANY SERVICES AND SELF-STORAGE FACILITIES FOR OTHERS (U.S. CLS. 100 AND 105).

FIRST USE 9-15-2010; IN COMMERCE 9-15-2010.

CLASS 39—(Continued).

4,119,228. CITYSTASH HOLDINGS, LLC, ARLINGTON, VA. SN 85-104,952. PUB. 12-14-2010, FILED 8-11-2010.



THE MARK CONSISTS OF A HOUSE DESIGN WITH A SERIES OF BACKGROUND VERTICAL LINES TO REPRESENT A BAR CODE, THE DESIGNS BEING TO THE LEFT OF THE LITERAL ELEMENT "CITYSTASH".
FOR PROVIDING MOVING COMPANY SERVICES AND SELF-STORAGE FACILITIES FOR OTHERS (U.S. CLS. 100 AND 105).
FIRST USE 9-15-2010; IN COMMERCE 9-15-2010.

CLASS 39—(Continued).

4,119,523. AMERICAN EXPRESS MARKETING & DEVELOPMENT CORP., NEW YORK, NY. SN 85-233,506. PUB. 5-24-2011, FILED 2-3-2011.



FOR ARRANGING TRAVEL TOURS, NAMELY, CUSTOMIZED MYSTERY TRIP BASED ON RESPONSES TO A QUIZ; CUSTOMIZED MYSTERY TRIP BASED ON RESPONSES TO A QUIZ, NAMELY, MAKING RESERVATIONS AND BOOKINGS FOR TRANSPORTATION (U.S. CLS. 100 AND 105).
FIRST USE 4-6-2011; IN COMMERCE 4-6-2011.

4,119,522. AMERICAN EXPRESS MARKETING & DEVELOPMENT CORP., NEW YORK, NY. SN 85-233,477. PUB. 5-24-2011, FILED 2-3-2011.

4,119,524. AMERICAN EXPRESS MARKETING & DEVELOPMENT CORP., NEW YORK, NY. SN 85-233,509. PUB. 5-24-2011, FILED 2-3-2011.



FOR ARRANGING TRAVEL TOURS, NAMELY, CUSTOMIZED MYSTERY TRIP BASED ON RESPONSES TO A QUIZ; CUSTOMIZED MYSTERY TRIP BASED ON RESPONSES TO A QUIZ, NAMELY, MAKING RESERVATIONS AND BOOKINGS FOR TRANSPORTATION (U.S. CLS. 100 AND 105).
FIRST USE 4-6-2011; IN COMMERCE 4-6-2011.



FOR ARRANGING TRAVEL TOURS, NAMELY, CUSTOMIZED MYSTERY TRIP BASED ON RESPONSES TO A QUIZ; CUSTOMIZED MYSTERY TRIP BASED ON RESPONSES TO A QUIZ, NAMELY, MAKING RESERVATIONS AND BOOKINGS FOR TRANSPORTATION (U.S. CLS. 100 AND 105).
FIRST USE 4-6-2011; IN COMMERCE 4-6-2011.

CLASS 39—(Continued).

4,119,525. AMERICAN EXPRESS MARKETING & DEVELOPMENT CORP., NEW YORK, NY. SN 85-233,571. PUB. 5-24-2011, FILED 2-3-2011.



FOR ARRANGING TRAVEL TOURS, NAMELY, CUSTOMIZED MYSTERY TRIP BASED ON RESPONSES TO A QUIZ; CUSTOMIZED MYSTERY TRIP BASED ON RESPONSES TO A QUIZ, NAMELY, MAKING RESERVATIONS AND BOOKINGS FOR TRANSPORTATION (U.S. CLS. 100 AND 105).
FIRST USE 4-6-2011; IN COMMERCE 4-6-2011.

4,119,577. FEDERAL EXPRESS CORPORATION, MEMPHIS, TN. SN 85-259,422. PUB. 5-17-2011, FILED 3-7-2011.

**FEDEX CUSTOM CRITICAL
ShipmentRescue**

THE MARK CONSISTS OF STANDARD CHARACTERS WITHOUT CLAIM TO ANY PARTICULAR FONT, STYLE, SIZE, OR COLOR.
OWNER OF U.S. REG. NOS. 2,657,697, 2,764,608, AND 3,125,953.
NO CLAIM IS MADE TO THE EXCLUSIVE RIGHT TO USE "SHIPMENT RESCUE", APART FROM THE MARK AS SHOWN.
FOR PROVIDING EMERGENCY SHIPPING SERVICES FOR CARGO (U.S. CLS. 100 AND 105).
FIRST USE 5-1-2011; IN COMMERCE 5-1-2011.

CLASS 39—(Continued).

4,119,617. ENTERPRISE HOLDINGS, INC., ST. LOUIS, MO. SN 85-283,771. PUB. 8-9-2011, FILED 4-1-2011.



OWNER OF U.S. REG. NOS. 3,503,173, 3,775,384, AND OTHERS.
THE COLOR(S) GREEN AND WHITE IS/ARE CLAIMED AS A FEATURE OF THE MARK.
THE MARK CONSISTS OF A WHITE, STYLIZED LETTER "E" ON A GREEN, BULB-SHAPED DESIGN ELEMENT.
FOR VEHICLE RENTAL AND LEASING SERVICES, AND RESERVATION SERVICES FOR THE RENTAL AND LEASING OF VEHICLES (U.S. CLS. 100 AND 105).
FIRST USE 12-19-2011; IN COMMERCE 12-19-2011.

4,119,633. BLUE STAR JETS, LLC, NEW YORK, NY. SN 85-294,134. PUB. 9-20-2011, FILED 4-13-2011.

PRIVATE JET MD

THE MARK CONSISTS OF STANDARD CHARACTERS WITHOUT CLAIM TO ANY PARTICULAR FONT, STYLE, SIZE, OR COLOR.
NO CLAIM IS MADE TO THE EXCLUSIVE RIGHT TO USE "PRIVATE JET", APART FROM THE MARK AS SHOWN.
FOR MEMBERSHIP AIR CHARTER SERVICES (U.S. CLS. 100 AND 105).
FIRST USE 11-1-2011; IN COMMERCE 11-1-2011.

CLASS 40—MATERIAL TREATMENT

CLASS 40—(Continued).

4,119,045. T-HOUSE, INC., PHILADELPHIA, PA. SN 77-960,674. PUB. 8-24-2010, FILED 3-16-2010.



NO CLAIM IS MADE TO THE EXCLUSIVE RIGHT TO USE "INC. YOUR LOGO HERE", APART FROM THE MARK AS SHOWN.

THE COLOR(S) BLACK, WHITE, RED, AND BLUE IS/ARE CLAIMED AS A FEATURE OF THE MARK.

THE MARK CONSISTS OF THE FOLLOWING: THE WORDING "T-HOUSE INC." IN BLACK AND THE DESIGN OF THREE T-SHIRTS IN RED, WHITE AND BLUE HANGING FROM A BLACK CLOTHESLINE AND CLOTHES PINS. THE T-SHIRTS CONTAIN THE WORDING "YOUR LOGO HERE" IN WHITE WITH BLACK OUTLINING. THE LETTER "O" IN "LOGO" IS FORMED BY THE PORTRAIT OF A MAN IN WHITE WITH BLACK OUTLINES.

FOR IMPRINTING MESSAGES ON T-SHIRTS; IMPRINTING MESSAGES ON WEARING APPAREL, ACCESSORIES AND MUGS; T-SHIRT EMBROIDERING SERVICES (U.S. CLS. 100, 103 AND 106).

FIRST USE 1-1-2010; IN COMMERCE 1-1-2010.

CLASS 41—(Continued).

4,118,779. REEL FX, INC., DALLAS, TX. SN 77-106,382. PUB. 5-20-2008, FILED 2-13-2007.

THE VERY FIRST NOEL

THE MARK CONSISTS OF STANDARD CHARACTERS WITHOUT CLAIM TO ANY PARTICULAR FONT, STYLE, SIZE, OR COLOR.

FOR PROVIDING WEBSITES FEATURING MUSICAL PERFORMANCE, MUSIC VIDEOS, RELATED FILM CLIPS, PHOTOGRAPHS, AND OTHER MULTIMEDIA MATERIALS (U.S. CLS. 100, 101 AND 107).

FIRST USE 8-31-2007; IN COMMERCE 8-31-2007.

4,118,794. FULL SAIL, LLC, WINTER PARK, FL. SN 77-301,971. PUB. 7-22-2008, FILED 10-11-2007.

UNCONVENTIONAL WISDOM

THE MARK CONSISTS OF STANDARD CHARACTERS WITHOUT CLAIM TO ANY PARTICULAR FONT, STYLE, SIZE, OR COLOR.

OWNER OF U.S. REG. NO. 2,052,894.

FOR EDUCATIONAL SERVICES, NAMELY, OFFERING COURSES OF INSTRUCTION IN ART, MUSIC, AUDIO, FILM, VIDEO, TELEVISION AND DIGITAL MEDIA (U.S. CLS. 100, 101 AND 107).

FIRST USE 1-20-2012; IN COMMERCE 1-20-2012.

4,119,149. BIELER & SCHNEIDER, LLC, NEW YORK, NY. SN 85-059,803. PUB. 11-2-2010, FILED 6-10-2010.

The Filling Station

THE MARK CONSISTS OF STANDARD CHARACTERS WITHOUT CLAIM TO ANY PARTICULAR FONT, STYLE, SIZE, OR COLOR.

FOR CUSTOM PRODUCTION OF WINE IN KEGS FOR OTHERS (U.S. CLS. 100, 103 AND 106).

FIRST USE 6-1-2011; IN COMMERCE 6-1-2011.

4,118,825. VERMILLION CRUSH, LLC, SAN FRANCISCO, CA. SN 77-449,676. PUB. 3-24-2009, FILED 4-16-2008.

Mr. Jimbers

CLASS 41—EDUCATION AND ENTERTAINMENT

THE MARK CONSISTS OF STANDARD CHARACTERS WITHOUT CLAIM TO ANY PARTICULAR FONT, STYLE, SIZE, OR COLOR.

CLASS 41—(Continued).

THE NAME(S), PORTRAIT(S), AND/OR SIGNATURE(S) SHOWN IN THE MARK DOES NOT IDENTIFY A PARTICULAR LIVING INDIVIDUAL.

FOR ENTERTAINMENT SERVICES IN THE NATURE OF LIVE-ACTION, COMEDY, DRAMA AND/OR ANIMATED TELEVISION PROGRAMS AND SERIES; PRODUCTION OF LIVE-ACTION, COMEDY, DRAMA AND ANIMATED TELEVISION SERIES; DISTRIBUTION AND DISPLAY OF LIVE-ACTION, COMEDY, DRAMA AND/OR ANIMATED MOTION PICTURE THEATRICAL FILMS; PRODUCTION OF LIVE-ACTION, COMEDY, DRAMA AND ANIMATED MOTION PICTURE THEATRICAL FILMS; LIVE PERFORMANCE THEATRICAL EXHIBITIONS FEATURING COSTUMED CHARACTERS; THEATRICAL PERFORMANCES BOTH ANIMATED AND LIVE ACTION; ENTERTAINMENT INFORMATION SERVICES PROVIDED VIA AN ELECTRONIC GLOBAL COMPUTER NETWORK IN THE FIELD OF ENTERTAINMENT INFORMATION RELATING SPECIFICALLY TO MUSIC, MOVIES, AND TELEVISION; PROVIDING NEWS AND EDUCATIONAL INFORMATION IN THE FIELD OF ENTERTAINMENT VIA A GLOBAL COMPUTER NETWORK (U.S. CLS. 100, 101 AND 107).

FIRST USE 5-1-2011; IN COMMERCE 5-1-2011.

4,118,827. CHET ZELASKO PHD, LLC, GRAND RAPIDS, MI.
SN 77-458,189. PUB. 9-30-2008, FILED 4-25-2008.

Body Tune-Up For Men

THE MARK CONSISTS OF STANDARD CHARACTERS WITHOUT CLAIM TO ANY PARTICULAR FONT, STYLE, SIZE, OR COLOR.

NO CLAIM IS MADE TO THE EXCLUSIVE RIGHT TO USE "FOR MEN", APART FROM THE MARK AS SHOWN.

FOR EDUCATIONAL SERVICES, NAMELY, LIVE AND ON-LINE SEMINARS, TUTORIALS AND WORKSHOPS REGARDING MEN'S HEALTH ISSUES, AND THE DISTRIBUTION OF PRINTED MATERIAL ASSOCIATED THEREWITH (U.S. CLS. 100, 101 AND 107).

FIRST USE 2-11-2011; IN COMMERCE 2-11-2011.

4,118,828. POLYGRAM HOLDING, INC., SANTA MONICA, CA. SN 77-460,869. PUB. 9-23-2008, FILED 4-29-2008.

KILLER MUSIC

THE MARK CONSISTS OF STANDARD CHARACTERS WITHOUT CLAIM TO ANY PARTICULAR FONT, STYLE, SIZE, OR COLOR.

OWNER OF U.S. REG. NO. 2,878,147.

CLASS 41—(Continued).

NO CLAIM IS MADE TO THE EXCLUSIVE RIGHT TO USE "MUSIC", APART FROM THE MARK AS SHOWN.

FOR PRODUCTION AND PUBLISHING OF MUSIC; ENTERTAINMENT SERVICES, NAMELY, PROVIDING ONLINE NON-DOWNLOADABLE MUSICAL AND THEATRICAL SOUND AND VIDEO RECORDINGS VIA A GLOBAL COMPUTER NETWORK; DEVELOPMENT AND DISSEMINATION OF EDUCATIONAL MATERIALS OF OTHERS IN THE FIELD OF MUSIC AND ENTERTAINMENT; RADIO ENTERTAINMENT PRODUCTION AND DISTRIBUTION; AUDIO AND SOUND RECORDING AND PRODUCTION; RECORD PRODUCTION; ENTERTAINMENT SERVICES IN THE NATURE OF PERFORMANCES RENDERED BY MUSICAL ARTISTS THROUGH THE MEDIUM OF TELEVISION, RADIO, AND AUDIO AND VIDEO RECORDINGS; ENTERTAINMENT SERVICES, NAMELY, RECORDED PERFORMANCES BY MUSICAL ARTISTS; ENTERTAINMENT SERVICES, NAMELY, PROVIDING A WEB SITE FEATURING MUSICAL PERFORMANCES, MUSICAL VIDEOS, RELATED FILM CLIPS, PHOTOGRAPHS, AND OTHER MULTIMEDIA MATERIALS; ENTERTAINMENT SERVICES, NAMELY, PROVIDING ON-LINE REVIEWS OF MUSIC, MUSICAL ARTISTS AND MUSIC VIDEOS; ENTERTAINMENT SERVICES, NAMELY, INFORMATION IN THE FIELD OF MUSIC, AND COMMENTARY AND ARTICLES ABOUT MUSIC, ALL ONLINE VIA A GLOBAL COMPUTER NETWORK; CONDUCTING ENTERTAINMENT EXHIBITIONS IN THE NATURE OF MUSIC FESTIVALS; ENTERTAINMENT SERVICES, NAMELY, CONDUCTING EXHIBITIONS IN THE FIELD OF MUSIC AND THE ARTS; ORGANIZING EXHIBITIONS FOR ENTERTAINMENT PURPOSES FEATURING MUSIC AND THE ARTS (U.S. CLS. 100, 101 AND 107).

FIRST USE 11-30-2007; IN COMMERCE 11-30-2007.

4,118,878. UNIVERSITY OF CHICAGO, THE, CHICAGO, IL.
SN 77-609,382. PUB. 9-29-2009, FILED 11-6-2008.

CHICAGO BOOTH 

The University of Chicago Booth School of Business

OWNER OF U.S. REG. NOS. 1,876,527 AND 2,668,437.
NO CLAIM IS MADE TO THE EXCLUSIVE RIGHT TO USE "CHICAGO" AND "SCHOOL OF BUSINESS", APART FROM THE MARK AS SHOWN.

THE MARK CONSISTS OF THE WORDS "CHICAGO BOOTH" TOGETHER WITH A DESIGN AND THE WORDS "THE UNIVERSITY OF CHICAGO BOOTH SCHOOL OF BUSINESS".

SEC. 2(F) AS TO "UNIVERSITY OF CHICAGO".

FOR PUBLISHING SERVICES, NAMELY, PUBLICATION OF BOOKS, PAMPHLETS, TEXTBOOKS AND OTHER MATERIALS COVERING A WIDE VARIETY OF TOPICS IN PRINT AND ELECTRONIC FORMAT (U.S. CLS. 100, 101 AND 107).

FIRST USE 3-0-2009; IN COMMERCE 3-0-2009.

CLASS 41—(Continued).

4,118,904. AWSUM ENTERPRISES INC., TA KAIZEN MARTIAL ARTS, PISCATAWAY, NJ. SN 77-697,863. PUB. 7-20-2010, FILED 3-24-2009.

KAIZEN KIDZ

THE MARK CONSISTS OF STANDARD CHARACTERS WITHOUT CLAIM TO ANY PARTICULAR FONT, STYLE, SIZE, OR COLOR.

NO CLAIM IS MADE TO THE EXCLUSIVE RIGHT TO USE "KIDS", APART FROM THE MARK AS SHOWN.

THE ENGLISH TRANSLATION OF "KAIZEN" IN THE MARK IS "CONSTANT AND NEVER ENDING IMPROVEMENT".

FOR ARRANGING AND CONDUCTING INCENTIVE AWARD PROGRAMS TO ENCOURAGE THE FREQUENT, CONTINUED AND EFFECTIVE PRACTICE OF PHYSICAL EXERCISE (U.S. CLS. 100, 101 AND 107).

FIRST USE 7-1-2008; IN COMMERCE 7-1-2008.

4,118,906. ADVANCE MAGAZINE PUBLISHERS INC., NEW YORK, NY. SN 77-709,659. PUB. 6-23-2009, FILED 4-8-2009.

LITTLE MISS FORTUNE

THE MARK CONSISTS OF STANDARD CHARACTERS WITHOUT CLAIM TO ANY PARTICULAR FONT, STYLE, SIZE, OR COLOR.

FOR ON-LINE JOURNALS, NAMELY, BLOGS FEATURING INFORMATION CONCERNING FINANCE AND MONEY (U.S. CLS. 100, 101 AND 107).

FIRST USE 4-30-2009; IN COMMERCE 4-30-2009.

4,118,912. DISNEY ENTERPRISES, INC., BURBANK, CA. SN 77-725,554. PUB. 10-26-2010, FILED 4-29-2009.

KICK BUTTOWSKI SUBURBAN DAREDEVIL

THE MARK CONSISTS OF STANDARD CHARACTERS WITHOUT CLAIM TO ANY PARTICULAR FONT, STYLE, SIZE, OR COLOR.

FOR ENTERTAINMENT SERVICES, NAMELY, AN ON-GOING ANIMATED TELEVISION SERIES; ENTERTAINMENT SERVICES, NAMELY, PROVIDING ONLINE ELECTRONIC GAMES AND ONLINE COMPUTER GAMES (U.S. CLS. 100, 101 AND 107).

FIRST USE 2-13-2010; IN COMMERCE 2-13-2010.

CLASS 41—(Continued).

4,118,927. CAREERPHYSICIAN ADVISORS, LP, SOUTHLAKE, TX. SN 77-771,565. PUB. 6-1-2010, FILED 6-30-2009.

CPCHEIFS

THE MARK CONSISTS OF STANDARD CHARACTERS WITHOUT CLAIM TO ANY PARTICULAR FONT, STYLE, SIZE, OR COLOR.

FOR EDUCATION SERVICES, NAMELY, PROVIDING LIVE, ONLINE AND COMPUTER-BASED INFORMATION, SEMINARS, AND FORUMS IN THE FIELD OF LEADERSHIP TRAINING TO HEALTH CARE PRACTITIONERS; EDUCATION SERVICES, NAMELY, PROVIDING LIVE, ONLINE AND COMPUTER-BASED SEMINARS AND FORUMS IN THE FIELDS OF CAREER AND PROFESSIONAL DEVELOPMENT TO HEALTH-CARE PRACTITIONERS (U.S. CLS. 100, 101 AND 107).

FIRST USE 12-31-2009; IN COMMERCE 12-31-2009.

4,118,980. MEDICINE WORLD ENTERPRISES, LLC, SOLEBURY, PA. SN 77-889,841. PUB. 10-26-2010, FILED 12-9-2009.

MEDICINE WOMAN, MODERN WORLD

THE MARK CONSISTS OF STANDARD CHARACTERS WITHOUT CLAIM TO ANY PARTICULAR FONT, STYLE, SIZE, OR COLOR.

FOR ENTERTAINMENT SERVICES, NAMELY, AN ON-GOING SERIES IN THE FIELDS OF MEDICINE, ALTERNATIVE MEDICINE, DIET, EXERCISE, FOOD, HEALTH, LIFESTYLE, NUTRITION AND WELLNESS PROVIDED THROUGH AUDIO AND VIDEO MEDIA, NAMELY, VIA TELEVISION, SATELLITE, WIRELESS NETWORKS, FIBER OPTICS, CABLE AND THE INTERNET (U.S. CLS. 100, 101 AND 107).

FIRST USE 11-30-2009; IN COMMERCE 11-30-2009.

CLASS 41—(Continued).

4,118,987. RANDALL-REILLY PUBLISHING COMPANY, LLC, TUSCALOOSA, AL. SN 77-899,266. PUB. 10-5-2010, FILED 12-22-2009.

PROPICKUP

THE MARK CONSISTS OF STANDARD CHARACTERS WITHOUT CLAIM TO ANY PARTICULAR FONT, STYLE, SIZE, OR COLOR.

FOR PROVIDING ON-LINE PUBLICATIONS, NAMELY, MAGAZINES COMPRISING ARTICLES IN THE FIELD OF TRUCKING, CONSTRUCTION, AND LANDSCAPING, AND A SERIES OF ARTICLES IN THE FIELD OF TRUCKING, CONSTRUCTION AND LANDSCAPING FOR BUSINESSES THAT USE TRUCKS FOR COMMERCIAL PURPOSES (U.S. CLS. 100, 101 AND 107).
FIRST USE 5-31-2010; IN COMMERCE 5-31-2010.

4,119,012. NATIONAL GLASS ASSOCIATION, MCLEAN, VA. SN 77-924,166. PUB. 6-15-2010, FILED 1-29-2010.

Window & Door Dealers Forum

NO CLAIM IS MADE TO THE EXCLUSIVE RIGHT TO USE "WINDOW & DOOR DEALERS FORUM", APART FROM THE MARK AS SHOWN.

THE MARK CONSISTS OF THE WORDING "WINDOW & DOOR DEALERS FORUM" SET BETWEEN HORIZONTAL LINES, WITH INTERLOCKING CIRCLES IN THE MIDDLE.

FOR EDUCATIONAL SERVICES, NAMELY, CONDUCTING CONFERENCES IN THE FIELD OF WINDOWS AND DOORS AND DISTRIBUTION OF COURSE MATERIAL IN CONNECTION THEREWITH (U.S. CLS. 100, 101 AND 107).

FIRST USE 9-15-2010; IN COMMERCE 9-15-2010.

CLASS 41—(Continued).

4,119,048. USO OF NORTH CAROLINA, INC, RALEIGH, NC. SN 77-968,360. PUB. 3-15-2011, FILED 3-25-2010.

SMILES OVER MILES

THE MARK CONSISTS OF STANDARD CHARACTERS WITHOUT CLAIM TO ANY PARTICULAR FONT, STYLE, SIZE, OR COLOR.

FOR PROVIDING A PROGRAM FOR MILITARY FAMILIES IN THE NATURE OF RECORDING PERSONALIZED DVDS FOR MILITARY FAMILIES TO SEND TO DEPLOYED SERVICE MEMBERS (U.S. CLS. 100, 101 AND 107).

FIRST USE 4-1-2010; IN COMMERCE 4-1-2010.

4,119,088. WHITE, STEPHEN, PORT WASHINGTON, NY. SN 85-027,702. PUB. 9-28-2010, FILED 4-30-2010.

ACTION, URGENCY & COMMITMENT, AUC

THE MARK CONSISTS OF STANDARD CHARACTERS WITHOUT CLAIM TO ANY PARTICULAR FONT, STYLE, SIZE, OR COLOR.

FOR EDUCATIONAL AND ENTERTAINMENT SERVICES, NAMELY, PROVIDING MOTIVATIONAL AND EDUCATIONAL SPEAKERS (U.S. CLS. 100, 101 AND 107).

FIRST USE 7-0-2011; IN COMMERCE 7-0-2011.

4,119,106. FIRARI, FAIRLIE, CAZENOVIA, NY. SN 85-039,342. PUB. 10-12-2010, FILED 5-14-2010.

E-Styles of Communication

THE MARK CONSISTS OF STANDARD CHARACTERS WITHOUT CLAIM TO ANY PARTICULAR FONT, STYLE, SIZE, OR COLOR.

NO CLAIM IS MADE TO THE EXCLUSIVE RIGHT TO USE "COMMUNICATION", APART FROM THE MARK AS SHOWN.

FOR TRAINING SERVICES IN THE FIELD OF BUSINESS COMMUNICATION FOR EFFECTIVELY WRITING AND READING EMAILS ACCORDING TO THE STYLES OF THE SENDERS AND RECEIVERS (U.S. CLS. 100, 101 AND 107).

FIRST USE 4-15-2010; IN COMMERCE 4-15-2010.

CLASS 41—(Continued).

4,119,121. KENNEDY-KLINE, TARA, SHOEMAKERSVILLE, PA. SN 85-046,781. PUB. 5-3-2011, FILED 5-24-2010.

Multi Level Mom

THE MARK CONSISTS OF STANDARD CHARACTERS WITHOUT CLAIM TO ANY PARTICULAR FONT, STYLE, SIZE, OR COLOR.

NO CLAIM IS MADE TO THE EXCLUSIVE RIGHT TO USE "MOM", APART FROM THE MARK AS SHOWN.

FOR EDUCATION SERVICES, NAMELY, PROVIDING CLASSES, SEMINARS IN THE FIELDS OF PERSONAL DEVELOPMENT AND LIFE BALANCING; EDUCATIONAL AND ENTERTAINMENT SERVICES, NAMELY, A CONTINUING PROGRAM ABOUT PERSONAL DEVELOPMENT AND LIFE BALANCING ACCESSIBLE BY RADIO, TELEVISION, SATELLITE, AUDIO, VIDEO AND COMPUTER NETWORKS; ON-LINE JOURNALS, NAMELY, BLOGS FEATURING LIFE EXPERIENCES, STORIES AND LESSONS ABOUT PERSONAL DEVELOPMENT AND LIFE BALANCING; PERSONAL COACHING SERVICES IN THE FIELD OF PERSONAL DEVELOPMENT AND LIFE BALANCING (U.S. CLS. 100, 101 AND 107).

FIRST USE 6-17-2010; IN COMMERCE 6-1-2011.

4,119,127. VOLLEYFROG, LLC, FORT MYERS, FL. SN 85-051,713. PUB. 5-3-2011, FILED 6-1-2010.

VOLLEYFROG

THE MARK CONSISTS OF STANDARD CHARACTERS WITHOUT CLAIM TO ANY PARTICULAR FONT, STYLE, SIZE, OR COLOR.

FOR PROVIDING A WEBSITE FEATURING NEWS AND INFORMATION IN THE FIELD OF VOLLEYBALL (U.S. CLS. 100, 101 AND 107).

FIRST USE 8-11-2011; IN COMMERCE 8-11-2011.

4,119,129. BRETT HICKEY, NEW YORK, NY. SN 85-053,279. PUB. 11-2-2010, FILED 6-2-2010.

AVAILOR GROUP

THE MARK CONSISTS OF STANDARD CHARACTERS WITHOUT CLAIM TO ANY PARTICULAR FONT, STYLE, SIZE, OR COLOR.

CLASS 41—(Continued).

NO CLAIM IS MADE TO THE EXCLUSIVE RIGHT TO USE "GROUP", APART FROM THE MARK AS SHOWN.

FOR EDUCATION SERVICES, NAMELY, PROVIDING CLASSES, SEMINARS, CONFERENCES AND EVENTS IN THE FIELD OF CHARITABLE CAUSES AND HUMAN SERVICES, HOW TO ESTABLISH AND RUN A CHARITY AND FUNDRAISING SKILLS; EDUCATIONAL AND ENTERTAINMENT SERVICES, NAMELY, PROVIDING MOTIVATIONAL AND EDUCATIONAL SPEAKERS; ENTERTAINMENT AND EDUCATIONAL SERVICES, NAMELY, PROVIDING ADVICE AND INFORMATION FOR MUSIC, VIDEO AND FILM CONCEPT AND SCRIPT DEVELOPMENT; ENTERTAINMENT MEDIA PRODUCTION SERVICES FOR MOTION PICTURES, TELEVISION AND INTERNET; MUSIC PRODUCTION SERVICES; PRODUCTION AND DISTRIBUTION OF TELEVISION SHOWS AND MOVIES; PRODUCTION OF RADIO OR TELEVISION PROGRAMS (U.S. CLS. 100, 101 AND 107).

FIRST USE 10-1-2011; IN COMMERCE 10-1-2011.

4,119,134. VOLLEYFROG, LLC, FORT MYERS, FL. SN 85-054,943. PUB. 5-3-2011, FILED 6-4-2010.

AS A TEAM WE ARE ONE

THE MARK CONSISTS OF STANDARD CHARACTERS WITHOUT CLAIM TO ANY PARTICULAR FONT, STYLE, SIZE, OR COLOR.

FOR PROVIDING A WEBSITE FEATURING NEWS AND INFORMATION IN THE FIELD OF VOLLEYBALL (U.S. CLS. 100, 101 AND 107).

FIRST USE 8-11-2011; IN COMMERCE 8-11-2011.

4,119,180. BATZ ENTERPRISES LLC, BLOOMINGTON, MN. SN 85-075,823. PUB. 11-30-2010, FILED 7-1-2010.

WHAT REALLY WORKS

THE MARK CONSISTS OF STANDARD CHARACTERS WITHOUT CLAIM TO ANY PARTICULAR FONT, STYLE, SIZE, OR COLOR.

FOR BUSINESS EDUCATION AND TRAINING SERVICES, NAMELY, DEVELOPING, AND FACILITATING CUSTOMIZED IN-COMPANY LEADERSHIP AND EXECUTIVE DEVELOPMENT PROGRAMS, PROVIDING EXECUTIVE COACHING SERVICES, AND PROVIDING PUBLIC AND IN-COMPANY KEYNOTE PRESENTATIONS TO BUSINESS LEADERS; PROVIDING GROUP COACHING AND LEARNING FORUMS IN THE FIELD OF LEADERSHIP DEVELOPMENT (U.S. CLS. 100, 101 AND 107).

FIRST USE 1-29-2010; IN COMMERCE 2-15-2011.

CLASS 41—(Continued).

4,119,233. SPORTS OUTDOOR AND RECREATION (SOAR) PARK, SAN ANTONIO, TX. SN 85-108,914. PUB. 11-23-2010, FILED 8-17-2010.

MORGAN

THE MARK CONSISTS OF STANDARD CHARACTERS WITHOUT CLAIM TO ANY PARTICULAR FONT, STYLE, SIZE, OR COLOR.

OWNER OF U.S. REG. NO. 3,800,756.
FOR PROVIDING THEME PARK SERVICES (U.S. CLS. 100, 101 AND 107).
FIRST USE 2-22-2010; IN COMMERCE 2-22-2010.

4,119,234. SPORTS OUTDOOR AND RECREATION (SOAR) PARK, SAN ANTONIO, TX. SN 85-108,973. PUB. 11-23-2010, FILED 8-17-2010.



THE COLOR(S) VIOLET, YELLOW, BROWN, PEACH, GREEN, PINK, WHITE AND BLACK IS/ARE CLAIMED AS A FEATURE OF THE MARK.

THE MARK CONSISTS OF A STYLIZED SUPERHUMAN CHARACTER IN THE FORM OF A YOUNG WOMAN HAVING LARGE VIOLET BUTTERFLY TYPE WINGS; THE CHARACTER IS WEARING PINK GLASSES AND A YELLOW AND VIOLET LEOTARD TYPE OUTFIT, VIOLET BOOTS, VIOLET GLOVES, A VIOLET SKIRT, AND A VIOLET AND YELLOW BELT; THE LETTERS "MW" APPEAR IN VIOLET ON THE CENTER OF THE CHARACTER'S SHIRT; THE CHARACTER HAS BROWN HAIR, GREEN, BLACK, AND WHITE EYES, PEACH SKIN, VIOLET LIPS WITH WHITE TEETH.

FOR PROVIDING THEME PARK SERVICES (U.S. CLS. 100, 101 AND 107).
FIRST USE 2-22-2010; IN COMMERCE 2-22-2010.

CLASS 41—(Continued).

4,119,235. SPORTS OUTDOOR AND RECREATION (SOAR) PARK, SAN ANTONIO, TX. SN 85-109,000. PUB. 11-23-2010, FILED 8-17-2010.



THE COLOR(S) PINK, RED, GOLD, GRAY, BLACK, BROWN, PEACH AND WHITE IS/ARE CLAIMED AS A FEATURE OF THE MARK.

THE MARK CONSISTS OF A STYLIZED SUPERHUMAN CHARACTER IN THE FORM OF A YOUNG WOMAN HOLDING FUTURISTIC GRAY AND PINK CRUTCHES WITH GRAY JET PACKS ATTACHED WITH RED STRIPES, WITH BLACK HAIR WITH RED HAIR PINS AND A PINK RIBBON, PEACH SKIN, BROWN, BLACK, AND WHITE EYES, AND A PINK MOUTH WITH WHITE TEETH, AND WEARING A PINK LEOTARD TYPE OUTFIT WITH RED BOOTS AND GLOVES, AND A RED AND GOLD BELT. THE LETTERS "MW" APPEAR IN PINK ON A RED CIRCLE ON THE CENTER OF THE CHARACTER'S SHIRT.

FOR PROVIDING THEME PARK SERVICES (U.S. CLS. 100, 101 AND 107).
FIRST USE 2-22-2010; IN COMMERCE 2-22-2010.

4,119,258. HOROWITZ, LEONARD G., PAHOA, HI. SN 85-127,035. PUB. 3-1-2011, FILED 9-10-2010.

MEDICAL VERITAS

THE MARK CONSISTS OF STANDARD CHARACTERS WITHOUT CLAIM TO ANY PARTICULAR FONT, STYLE, SIZE, OR COLOR.

OWNER OF U.S. REG. NO. 3,004,348.
NO CLAIM IS MADE TO THE EXCLUSIVE RIGHT TO USE "MEDICAL", APART FROM THE MARK AS SHOWN.
FOR ONLINE ELECTRONIC PUBLISHING OF BOOKS AND PERIODICALS IN THE FIELD OF MEDICINE (U.S. CLS. 100, 101 AND 107).

FIRST USE 8-25-2004; IN COMMERCE 8-25-2004.

CLASS 41—(Continued).

4,119,268. DISCOVERY COMMUNICATIONS, LLC, SILVER SPRING, MD. SN 85-133,990. PUB. 10-18-2011, FILED 9-20-2010.

FABULOUS CAKES

THE MARK CONSISTS OF STANDARD CHARACTERS WITHOUT CLAIM TO ANY PARTICULAR FONT, STYLE, SIZE, OR COLOR.

NO CLAIM IS MADE TO THE EXCLUSIVE RIGHT TO USE "CAKES", APART FROM THE MARK AS SHOWN.

FOR ENTERTAINMENT AND EDUCATIONAL SERVICES IN THE NATURE OF TELEVISION AND MULTIMEDIA PROGRAM SERIES FEATURING SUBJECTS OF GENERAL HUMAN INTEREST DISTRIBUTED VIA VARIOUS PLATFORMS ACROSS MULTIPLE FORMS OF TRANSMISSION MEDIA; PROVIDING ENTERTAINMENT INFORMATION TO OTHERS VIA A GLOBAL COMPUTER NETWORK (U.S. CLS. 100, 101 AND 107).

FIRST USE 7-19-2010; IN COMMERCE 7-19-2010.

CLASS 41—(Continued).

4,119,339. INTERNATIONAL PAPER COMPANY, MEMPHIS, TN. SN 85-183,545. PUB. 5-24-2011, FILED 11-23-2010.

**SUSTAINABLE BY NATURE.
RESOURCEFUL BY DESIGN.**

THE MARK CONSISTS OF STANDARD CHARACTERS WITHOUT CLAIM TO ANY PARTICULAR FONT, STYLE, SIZE, OR COLOR.

FOR EDUCATIONAL SERVICES, NAMELY, CONDUCTING INFORMAL PROGRAMS IN THE FIELD OF THE PAPERBOARD AND CORRUGATED PACKAGING INDUSTRY RELATED TO RECYCLING POST CONSUMER CONTENT AND RESOURCE SUSTAINABILITY USING ON-LINE ACTIVITIES AND INTERACTIVE EXHIBITS, AND PRINTABLE MATERIALS DISTRIBUTED THEREWITH; PROVIDING ON-LINE NON-DOWNLOADABLE PUBLICATIONS IN THE NATURE OF NEWSLETTERS IN THE FIELD OF THE PAPERBOARD AND CORRUGATED PACKAGING INDUSTRY RELATED TO RECYCLING POST CONSUMER CONTENT AND RESOURCE SUSTAINABILITY (U.S. CLS. 100, 101 AND 107).

FIRST USE 9-30-2010; IN COMMERCE 9-30-2010.

4,119,340. CALVERT SCHOOL, BALTIMORE, MD. SN 85-183,858. PUB. 5-3-2011, FILED 11-23-2010.

4,119,312. TALMI, BEN, BOSTON, MA. SN 85-163,220. PUB. 7-5-2011, FILED 10-28-2010.

ART DECADE

THE MARK CONSISTS OF STANDARD CHARACTERS WITHOUT CLAIM TO ANY PARTICULAR FONT, STYLE, SIZE, OR COLOR.

FOR ENTERTAINMENT SERVICES, NAMELY, PRODUCTION OF A SERIES OF MUSICAL SOUND RECORDINGS; LIVE PERFORMANCES BY A MUSICAL GROUP (U.S. CLS. 100, 101 AND 107).

FIRST USE 9-9-2009; IN COMMERCE 9-9-2009.



OWNER OF U.S. REG. NOS. 1,593,508 AND 1,601,464.
NO CLAIM IS MADE TO THE EXCLUSIVE RIGHT TO USE "SCHOOL", APART FROM THE MARK AS SHOWN.
THE COLOR(S) YELLOW, BLACK AND WHITE IS/ARE CLAIMED AS A FEATURE OF THE MARK.

THE MARK CONSISTS OF A SILHOUETTE OF A BOY'S HEAD IN BLACK APPEARING ON A YELLOW CIRCLE WHICH IS ENCLOSED WITHIN A LARGER CONCENTRIC WHITE CIRCLE SURROUNDED BY A BLACK CIRCLE AND HAVING STEM AND LEAF DESIGNS IN BLACK AND WHITE EXTENDING FROM ITS OPPOSITE SIDES WITH THE WORDS "CALVERT SCHOOL" BELOW IN STYLIZED BLACK LETTERS AND WITH THE WORDS "CURIOSITY, MASTERY, PURPOSE" ALSO IN STYLIZED BLACK LETTERS SEPARATED BY TWO BLACK DOTS AT THE VERY BOTTOM.

FOR EDUCATIONAL SERVICES, NAMELY, PROVIDING COURSES OF INSTRUCTION AT THE PRE-KINDERGARTEN THROUGH EIGHTH GRADE LEVELS (U.S. CLS. 100, 101 AND 107).

FIRST USE 9-30-2009; IN COMMERCE 9-30-2010.

CLASS 41—(Continued).

4,119,346. SALESFORCE.COM, INC., SAN FRANCISCO, CA. SN 85-184,995. PUB. 4-12-2011, FILED 11-24-2010.

CHATTY

THE MARK CONSISTS OF STANDARD CHARACTERS WITHOUT CLAIM TO ANY PARTICULAR FONT, STYLE, SIZE, OR COLOR.

FOR ENTERTAINMENT SERVICES IN THE NATURE OF PERSONAL APPEARANCES BY A COSTUMED MASCOT (U.S. CLS. 100, 101 AND 107).
FIRST USE 11-18-2009; IN COMMERCE 11-18-2009.

4,119,373. SEREBRENNIKOV, BORIS L., SHREWSBURY, MA. SN 85-194,742. PUB. 5-24-2011, FILED 12-9-2010.

Think, Learn, Succeed

THE MARK CONSISTS OF STANDARD CHARACTERS WITHOUT CLAIM TO ANY PARTICULAR FONT, STYLE, SIZE, OR COLOR.

NO CLAIM IS MADE TO THE EXCLUSIVE RIGHT TO USE "LEARN", APART FROM THE MARK AS SHOWN.

FOR CONDUCTING AFTER SCHOOL TUTORING PROGRAMS; EDUCATION SERVICES, NAMELY, PROVIDING MENTORING, TUTORING, CLASSES, SEMINARS AND WORKSHOPS IN THE FIELD OF MATHEMATICS FOR LEVELS K THROUGH 12 CONSISTING OF ELEMENTARY MATHEMATICS, PRE-ALGEBRA, ALGEBRA, CALCULUS AND GEOMETRY (U.S. CLS. 100, 101 AND 107).

FIRST USE 6-22-2011; IN COMMERCE 6-22-2011.

4,119,390. VIRGINIA LEGENDS ELITE SOFTBALL ORGANIZATION, LLC, CHESAPEAKE, VA. SN 85-198,279. PUB. 5-10-2011, FILED 12-15-2010.



NO CLAIM IS MADE TO THE EXCLUSIVE RIGHT TO USE "VIRGINIA" AND "SOFTBALL", APART FROM THE MARK AS SHOWN.

CLASS 41—(Continued).

THE MARK CONSISTS OF TWO OVALS WITH THE STYLIZED TEXT "VIRGINIA LEGENDS ELITE SOFTBALL".

FOR SPORTS TRAINING SERVICES (U.S. CLS. 100, 101 AND 107).
FIRST USE 9-1-2010; IN COMMERCE 9-1-2010.

4,119,414. BODY INFUSION BY HER, LLC, WILMINGTON, MA. SN 85-202,758. PUB. 5-17-2011, FILED 12-21-2010.

BODY INFUSION BY HER

THE MARK CONSISTS OF STANDARD CHARACTERS WITHOUT CLAIM TO ANY PARTICULAR FONT, STYLE, SIZE, OR COLOR.

FOR PHYSICAL FITNESS TRAINING SERVICES (U.S. CLS. 100, 101 AND 107).
FIRST USE 11-30-2009; IN COMMERCE 4-6-2011.

4,119,415. SARANTAKOS, CHRISTOPHER, AKA CRISS ANGEL, WOODBURY, NY. SN 85-202,831. PUB. 5-10-2011, FILED 12-21-2010.

CRISS ANGEL MAGICJAM

THE MARK CONSISTS OF STANDARD CHARACTERS WITHOUT CLAIM TO ANY PARTICULAR FONT, STYLE, SIZE, OR COLOR.

OWNER OF U.S. REG. NOS. 1,705,520 AND 3,425,904.
THE NAME "CRIS ANGEL" IDENTIFIES THE STAGE NAME OF CHRISTOPHER SARANTAKOS, A LIVING INDIVIDUAL WHOSE CONSENT IS OF RECORD.

FOR ENTERTAINMENT SERVICES, NAMELY, PROVIDING WEBCASTS IN THE FIELD OF MAGIC AND ILLUSION (U.S. CLS. 100, 101 AND 107).
FIRST USE 8-15-2011; IN COMMERCE 8-15-2011.

CLASS 41—(Continued).

4,119,437. ORTHODYNAMICS INTERNATIONAL LLC, CROTON ON HUDSON, NY. SN 85-208,273. PUB. 5-24-2011, FILED 12-30-2010.

ORTHODYNAMICS

THE MARK CONSISTS OF STANDARD CHARACTERS WITHOUT CLAIM TO ANY PARTICULAR FONT, STYLE, SIZE, OR COLOR.

FOR PERSONAL FITNESS TRAINING SERVICES AND CONSULTANCY (U.S. CLS. 100, 101 AND 107).
FIRST USE 1-2-2012; IN COMMERCE 1-2-2012.

4,119,465. STUART, BRUCE S, SAN FRANCISCO, CA. SN 85-215,511. PUB. 7-5-2011, FILED 1-12-2011.

THE LIGHTENING ROUND

THE MARK CONSISTS OF STANDARD CHARACTERS WITHOUT CLAIM TO ANY PARTICULAR FONT, STYLE, SIZE, OR COLOR.

FOR PROVIDING ONLINE PUBLICATIONS IN THE NATURE OF BLOGS AND NONDOWNLOADABLE BOOKS, MAGAZINES, AND NEWSLETTERS, ALL IN THE FIELD OF FICTION (U.S. CLS. 100, 101 AND 107).
FIRST USE 5-24-2011; IN COMMERCE 5-24-2011.

4,119,507. WP COMPANY LLC, WASHINGTON, DC. SN 85-226,220. PUB. 5-3-2011, FILED 1-26-2011.

2CHAMBERS

THE MARK CONSISTS OF STANDARD CHARACTERS WITHOUT CLAIM TO ANY PARTICULAR FONT, STYLE, SIZE, OR COLOR.

FOR ONLINE JOURNALS, NAMELY, A BLOG ON THE SUBJECTS OF THE UNITED STATES CONGRESS AND ITS MEMBERS, COMMITTEES, SUBCOMMITTEES, STAFFERS AND LOBBYISTS, AND THEIR CONSIDERATION OF, INTERACTION WITH AND EFFECT ON DOMESTIC AND INTERNATIONAL LEGISLATION, PUBLIC POLICY ISSUES AND ELECTIONS (U.S. CLS. 100, 101 AND 107).
FIRST USE 2-24-2011; IN COMMERCE 2-24-2011.

CLASS 41—(Continued).

4,119,509. DISNEY ENTERPRISES, INC., BURBANK, CA. SN 85-228,264. PUB. 5-31-2011, FILED 1-27-2011.

THE LITTLE MERMAID

THE MARK CONSISTS OF STANDARD CHARACTERS WITHOUT CLAIM TO ANY PARTICULAR FONT, STYLE, SIZE, OR COLOR.

FOR THEME PARK SERVICES (U.S. CLS. 100, 101 AND 107).
FIRST USE 6-3-2011; IN COMMERCE 6-3-2011.

4,119,538. HI-REZ STUDIOS, INC., ALPHARETTA, GA. SN 85-238,337. PUB. 6-14-2011, FILED 2-9-2011.

SMITE

THE MARK CONSISTS OF STANDARD CHARACTERS WITHOUT CLAIM TO ANY PARTICULAR FONT, STYLE, SIZE, OR COLOR.

FOR ENTERTAINMENT SERVICES IN THE NATURE OF AN ONLINE INTERACTIVE GAME PROVIDED BY MEANS OF A GLOBAL COMPUTER NETWORK; PROVIDING INFORMATION ONLINE RELATING TO COMPUTER GAMES, ONLINE COMPUTER GAMES, COMPUTER GAME ENTERTAINMENT AND AMUSEMENT ACTIVITIES, AND MULTI-PLAYER ONLINE COMPUTER GAME COOPERATION AND COMPETITIONS; PUBLISHING OF ELECTRONIC PUBLICATIONS (U.S. CLS. 100, 101 AND 107).
FIRST USE 4-21-2011; IN COMMERCE 4-21-2011.

4,119,557. ALLEGHENY COUNTY DISTRICT ATTORNEY'S OFFICE, PITTSBURGH, PA. SN 85-249,448. PUB. 9-6-2011, FILED 2-23-2011.

YOU CANT ERASE CYBERSPACE

THE MARK CONSISTS OF STANDARD CHARACTERS WITHOUT CLAIM TO ANY PARTICULAR FONT, STYLE, SIZE, OR COLOR.

FOR EDUCATION SERVICES, NAMELY, PROVIDING CLASSES AND SEMINARS IN THE FIELD OF CRIME PREVENTION (U.S. CLS. 100, 101 AND 107).
FIRST USE 3-24-2011; IN COMMERCE 3-24-2011.

CLASS 41—(Continued).

4,119,581. HI-REZ STUDIOS, INC., ALPHARETTA, GA. SN 85-260,929. PUB. 6-14-2011, FILED 3-8-2011.

TRIBES ASCEND

THE MARK CONSISTS OF STANDARD CHARACTERS WITHOUT CLAIM TO ANY PARTICULAR FONT, STYLE, SIZE, OR COLOR.

FOR ENTERTAINMENT SERVICES IN THE NATURE OF AN ONLINE INTERACTIVE GAME PROVIDED BY MEANS OF A GLOBAL COMPUTER NETWORK; PROVIDING INFORMATION ONLINE RELATING TO COMPUTER GAMES, ONLINE COMPUTER GAMES, COMPUTER GAME ENTERTAINMENT AND AMUSEMENT ACTIVITIES, AND MULTI-PLAYER ONLINE COMPUTER GAME COOPERATION AND COMPETITIONS; PUBLISHING OF ELECTRONIC PUBLICATIONS (U.S. CLS. 100, 101 AND 107).

FIRST USE 3-11-2011; IN COMMERCE 3-11-2011.

4,119,583. PATRIOTIC PRODUCTIONS, LLC, OMAHA, NE. SN 85-262,096. PUB. 7-26-2011, FILED 3-9-2011.

REMEMBERING OUR FALLEN

THE MARK CONSISTS OF STANDARD CHARACTERS WITHOUT CLAIM TO ANY PARTICULAR FONT, STYLE, SIZE, OR COLOR.

FOR EDUCATIONAL SERVICES, NAMELY, PROVIDING DISPLAYS AND EXHIBITS HONORING DECEASED WAR VETERANS (U.S. CLS. 100, 101 AND 107).

FIRST USE 4-15-2011; IN COMMERCE 4-15-2011.

4,119,591. BURSTYN, ADAM, MIAMI, FL. SN 85-266,214. PUB. 9-6-2011, FILED 3-14-2011.

**BUA SPORTS PERFORMANCE
BECOME THE ULTIMATE ATHLETE**

THE MARK CONSISTS OF STANDARD CHARACTERS WITHOUT CLAIM TO ANY PARTICULAR FONT, STYLE, SIZE, OR COLOR.

NO CLAIM IS MADE TO THE EXCLUSIVE RIGHT TO USE "SPORTS PERFORMANCE", APART FROM THE MARK AS SHOWN.

FOR SPORTS AND FITNESS TRAINING SERVICES (U.S. CLS. 100, 101 AND 107).

FIRST USE 12-6-2011; IN COMMERCE 12-6-2011.

CLASS 41—(Continued).

4,119,606. MARQUEZE, RHANDY, SÃO PAULO, BRAZIL. SN 85-274,114. PUB. 8-23-2011, FILED 3-23-2011.

**ICI INTEGRATED COACHING
INSTITUTE**

THE MARK CONSISTS OF STANDARD CHARACTERS WITHOUT CLAIM TO ANY PARTICULAR FONT, STYLE, SIZE, OR COLOR.

NO CLAIM IS MADE TO THE EXCLUSIVE RIGHT TO USE "INTEGRATED COACHING INSTITUTE", APART FROM THE MARK AS SHOWN.

FOR EDUCATIONAL SERVICES, NAMELY, CONDUCTING CLASSES, SEMINARS, CONFERENCES, WORKSHOPS IN THE FIELD OF PERSONAL AND EXECUTIVE COACHING, AND DISTRIBUTION OF TRAINING MATERIAL IN CONNECTION THEREWITH; EDUCATIONAL AND ENTERTAINMENT SERVICES, NAMELY, PROVIDING MOTIVATIONAL AND EDUCATIONAL SPEAKERS (U.S. CLS. 100, 101 AND 107).

FIRST USE 10-1-2001; IN COMMERCE 10-1-2001.

4,119,634. ADAMS, BLAIR, SAN ANSELMO, CA. SN 85-294,684. PUB. 9-13-2011, FILED 4-13-2011.

**DOWNSIZED LIVING THE
MAGAZINE FOR THE NEW
AMERICA**

THE MARK CONSISTS OF STANDARD CHARACTERS WITHOUT CLAIM TO ANY PARTICULAR FONT, STYLE, SIZE, OR COLOR.

NO CLAIM IS MADE TO THE EXCLUSIVE RIGHT TO USE "MAGAZINE" OR "AMERICA", APART FROM THE MARK AS SHOWN.

FOR PROVIDING ON-LINE E-ZINES IN THE FIELD OF PARODY AND DARK HUMOR TO CALL ATTENTION TO THE ECONOMICALLY DISTRESSED AND DESPERATE CIRCUMSTANCES IN WHICH AMERICANS FIND THEMSELVES TODAY (U.S. CLS. 100, 101 AND 107).

FIRST USE 10-5-2011; IN COMMERCE 10-5-2011.

4,119,649. JOAN SINGER, NEW YORK, NY. SN 85-300,001. PUB. 10-25-2011, FILED 4-20-2011.

BICYCLE SPANISH

THE MARK CONSISTS OF STANDARD CHARACTERS WITHOUT CLAIM TO ANY PARTICULAR FONT, STYLE, SIZE, OR COLOR.

CLASS 41—(Continued).

NO CLAIM IS MADE TO THE EXCLUSIVE RIGHT TO USE "SPANISH", APART FROM THE MARK AS SHOWN.
 FOR SPANISH LANGUAGE INSTRUCTION (U.S. CLS. 100, 101 AND 107).
 FIRST USE 8-22-2011; IN COMMERCE 8-22-2011.

4,119,654. PRZYBYLO, DAVID, SCHENECTADY, NY. SN 85-304,081. PUB. 9-20-2011, FILED 4-25-2011.

SUSTAINED EFFORT

THE MARK CONSISTS OF STANDARD CHARACTERS WITHOUT CLAIM TO ANY PARTICULAR FONT, STYLE, SIZE, OR COLOR.
 FOR EDUCATIONAL SERVICES, NAMELY, PROVIDING CLASSES, SEMINARS, WORKSHOPS, PROGRAMS AND CONFERENCES IN THE FIELDS OF ACADEMIC MOTIVATION AND ACHIEVEMENT, PERSONAL IMPROVEMENT, PHYSICAL FITNESS, GOAL SETTING AND PRODUCTIVITY (U.S. CLS. 100, 101 AND 107).
 FIRST USE 0-0-2011; IN COMMERCE 0-0-2011.

4,119,655. GRANT, BOB, ACWORTH, GA. SN 85-305,091. PUB. 9-13-2011, FILED 4-26-2011.

THE WOMEN MEN ADORE

THE MARK CONSISTS OF STANDARD CHARACTERS WITHOUT CLAIM TO ANY PARTICULAR FONT, STYLE, SIZE, OR COLOR.
 FOR ARRANGING OF CONTESTS; ENTERTAINMENT SERVICES, NAMELY, CONDUCTING CONTESTS (U.S. CLS. 100, 101 AND 107).
 FIRST USE 1-1-2012; IN COMMERCE 1-1-2012.

4,119,658. ROSEN HOTELS AND RESORTS, INC., ORLANDO, FL. SN 85-308,206. PUB. 10-4-2011, FILED 4-29-2011.

FIT DEPUTY

THE MARK CONSISTS OF STANDARD CHARACTERS WITHOUT CLAIM TO ANY PARTICULAR FONT, STYLE, SIZE, OR COLOR.

CLASS 41—(Continued).

NO CLAIM IS MADE TO THE EXCLUSIVE RIGHT TO USE "FIT", APART FROM THE MARK AS SHOWN.
 FOR PROVIDING INFORMATION TO LAW ENFORCEMENT AND GOVERNMENTAL AGENCIES THROUGH THE GLOBAL COMPUTER NETWORK CONCERNING FITNESS AND EXERCISE FACILITIES, COMPANIES AND ORGANIZATIONS WHICH OFFER HEALTH, FITNESS AND NUTRITIONAL OPPORTUNITIES TO LAW ENFORCEMENT AT SPECIAL RATES (U.S. CLS. 100, 101 AND 107).
 FIRST USE 3-10-2011; IN COMMERCE 3-10-2011.

4,119,674. WEXLER, LEE, NEW YORK, NY. SN 85-318,722. PUB. 9-27-2011, FILED 5-11-2011.

Images for Innovation

THE MARK CONSISTS OF STANDARD CHARACTERS WITHOUT CLAIM TO ANY PARTICULAR FONT, STYLE, SIZE, OR COLOR.
 FOR PHOTOGRAPHY; PHOTOGRAPHY SERVICES (U.S. CLS. 100, 101 AND 107).
 FIRST USE 9-1-2011; IN COMMERCE 9-1-2011.

4,119,690. PATHWAY TO WISDOM, LLC, STOW, OH. SN 85-328,397. PUB. 11-8-2011, FILED 5-24-2011.

PATHWAY TO WISDOM

THE MARK CONSISTS OF STANDARD CHARACTERS WITHOUT CLAIM TO ANY PARTICULAR FONT, STYLE, SIZE, OR COLOR.
 FOR PERSONAL COACHING SERVICES IN THE FIELD OF LIFE SKILLS (U.S. CLS. 100, 101 AND 107).
 FIRST USE 9-16-2011; IN COMMERCE 9-16-2011.

CLASS 41—(Continued).

4,119,705. INSTITUTE FOR SCHOOL EXCELLENCE, INDIANAPOLIS, IN. SN 85-347,189. PUB. 11-1-2011, FILED 6-15-2011.

EUNOIA

THE MARK CONSISTS OF STANDARD CHARACTERS WITHOUT CLAIM TO ANY PARTICULAR FONT, STYLE, SIZE, OR COLOR.

FOR EDUCATIONAL SERVICES, NAMELY, PROVIDING COURSES OF INSTRUCTION AT THE PRIMARY AND SECONDARY LEVEL, SPECIFICALLY, LEVELS K-12 AND DISTRIBUTION OF COURSE MATERIAL IN CONNECTION THEREWITH (U.S. CLS. 100, 101 AND 107).

FIRST USE 8-26-2011; IN COMMERCE 8-26-2011.

4,119,723. REED ELSEVIER PROPERTIES INC., WILMINGTON, DE. SN 85-976,187. PUB. 6-14-2011, FILED 2-11-2011.

BLOGDOGGER

THE MARK CONSISTS OF STANDARD CHARACTERS WITHOUT CLAIM TO ANY PARTICULAR FONT, STYLE, SIZE, OR COLOR.

FOR PROVISION OF ENTERTAINMENT INDUSTRY INFORMATION AND NEWS ONLINE (U.S. CLS. 100, 101 AND 107).

FIRST USE 2-28-2011, THE MARK WAS FIRST USED ANYWHERE IN A DIFFERENT FORM OTHER THAN THAT SOUGHT TO BE REGISTERED AT LEAST AS EARLY AS 01/26/2011. ; IN COMMERCE 2-28-2011, THE MARK WAS FIRST USED IN COMMERCE IN A DIFFERENT FORM OTHER THAN THAT SOUGHT TO BE REGISTERED AT LEAST AS EARLY AS 01/26/2011..

CLASS 42—SCIENTIFIC AND COMPUTER SERVICES

4,118,784. NEXTBIO, CUPERTINO, CA. SN 77-197,295. PUB. 4-29-2008, FILED 6-4-2007.

NEXTBIO

THE MARK CONSISTS OF STANDARD CHARACTERS WITHOUT CLAIM TO ANY PARTICULAR FONT, STYLE, SIZE, OR COLOR.

CLASS 42—(Continued).

OWNER OF U.S. REG. NO. 3,143,004.

FOR PROVIDING ON-LINE NON-DOWNLOADABLE COMPUTER SOFTWARE FOR ACCESSING, MANAGING, AND SEARCHING DATA IN THE FIELDS OF LIFE SCIENCES AND DRUG DISCOVERY; PROVIDING ON-LINE NONDOWNLOADABLE COMPUTER-SEARCH-ENGINE SOFTWARE (U.S. CLS. 100 AND 101). FIRST USE 10-0-2006; IN COMMERCE 10-0-2006.

4,118,814. SANOFI PASTEUR VAXDESIGN CORPORATION, WILMINGTON, DE. SN 77-389,023. PUB. 11-25-2008, FILED 2-5-2008.

CLINICAL TRIAL IN A WELL

THE MARK CONSISTS OF STANDARD CHARACTERS WITHOUT CLAIM TO ANY PARTICULAR FONT, STYLE, SIZE, OR COLOR.

FOR RESEARCH, DEVELOPMENT, ENGINEERING AND TESTING SERVICES IN THE FIELDS OF IMMUNOPHARMACEUTICALS AND VACCINES (U.S. CLS. 100 AND 101).

FIRST USE 1-19-2012; IN COMMERCE 1-19-2012.

4,118,882. PORTFOLIO PATHWAY, LLC, NAPERVILLE, IL. SN 77-627,433. PUB. 11-24-2009, FILED 12-5-2008.

PORTFOLIO PATHWAY

THE MARK CONSISTS OF STANDARD CHARACTERS WITHOUT CLAIM TO ANY PARTICULAR FONT, STYLE, SIZE, OR COLOR.

NO CLAIM IS MADE TO THE EXCLUSIVE RIGHT TO USE "PORTFOLIO", APART FROM THE MARK AS SHOWN.

FOR PROVIDING TEMPORARY USE OF ON-LINE NON-DOWNLOADABLE SOFTWARE FOR FINANCIAL PROFESSIONALS FOR USE IN MANAGING CLIENT ACCOUNTS ACROSS MULTIPLE INSTITUTIONS THROUGH A WEB PORTAL INTERFACE; PROVIDING A WEBSITE FEATURING ON-LINE NON-DOWNLOADABLE SOFTWARE THAT MANAGES THE USER'S FINANCIAL INFORMATION FROM A VARIETY OF FINANCIAL INSTITUTIONS; PROVIDING A WEBSITE FOR FINANCIAL PROFESSIONALS FEATURING ON-LINE NON-DOWNLOADABLE SOFTWARE THAT MANAGES CUSTOMER'S FINANCIAL ACCOUNTS THROUGH PERFORMANCE REPORTING, OPERATIONAL WORKFLOW, AND ACCOUNT AGGREGATION (U.S. CLS. 100 AND 101).

FIRST USE 3-15-2010; IN COMMERCE 3-15-2010.

CLASS 42—(Continued).

4,118,930. PERCEPTIVE INFORMATICS, INC., WALTHAM, MA. SN 77-773,526. PUB. 1-12-2010, FILED 7-2-2009.

PERCEPTIVE

THE MARK CONSISTS OF STANDARD CHARACTERS WITHOUT CLAIM TO ANY PARTICULAR FONT, STYLE, SIZE, OR COLOR.

OWNER OF U.S. REG. NOS. 3,142,466 AND 3,190,512.

FOR APPLICATION SERVICE PROVIDER SERVICES, NAMELY, PROVIDING TEMPORARY USE OF ON-LINE NON-DOWNLOADABLE SOFTWARE FOR USE IN MANAGING THE DRUG DEVELOPMENT PROCESS, CAPTURING ELECTRONIC DATA, AND MANAGING PATIENT ENROLLMENT INFORMATION AND DRUG DEVELOPMENT DATA; COMPUTER SERVICES, NAMELY, A COMPUTER NETWORK PORTAL WEB SITE FEATURING CLINICAL AND MEDICAL RESEARCH INFORMATION AND CLINICAL TRIAL DATA TO PHARMACEUTICAL, BIOTECHNOLOGY AND MEDICAL DEVICE INDUSTRIES; DEVELOPING COMPUTER SOFTWARE APPLICATIONS FOR PHARMACEUTICAL, BIOTECHNOLOGY AND MEDICAL DEVICE COMPANIES; APPLICATION SERVICE PROVIDER (ASP) SERVICES, NAMELY, HOSTING COMPUTER SOFTWARE APPLICATIONS FOR PHARMACEUTICAL, BIOTECHNOLOGY AND MEDICAL DEVICE COMPANIES (U.S. CLS. 100 AND 101).

FIRST USE 2-28-2002; IN COMMERCE 2-28-2002.

4,118,936. ETW INTERNATIONAL, CHICAGO, IL. SN 77-807,270. PUB. 11-30-2010, FILED 8-18-2009.

ETW International

THE MARK CONSISTS OF STANDARD CHARACTERS WITHOUT CLAIM TO ANY PARTICULAR FONT, STYLE, SIZE, OR COLOR.

NO CLAIM IS MADE TO THE EXCLUSIVE RIGHT TO USE "INTERNATIONAL", APART FROM THE MARK AS SHOWN.

FOR PROVISION OF INTERNET SEARCH ENGINES (U.S. CLS. 100 AND 101).

FIRST USE 9-1-2004; IN COMMERCE 9-1-2004.

CLASS 42—(Continued).

4,118,951. SYMRISE AG, HOLZMINDEN, FED REP GER-MANY. SN 77-844,696. PUB. 3-9-2010, FILED 10-8-2009.

SYMSELECT

THE MARK CONSISTS OF STANDARD CHARACTERS WITHOUT CLAIM TO ANY PARTICULAR FONT, STYLE, SIZE, OR COLOR.

FOR PLATFORM AS A SERVICE (PAAS) FEATURING COMPUTER SOFTWARE PLATFORMS FOR E-COMMERCE TO ALLOW USERS TO PERFORM ELECTRONIC BUSINESS TRANSACTIONS VIA A GLOBAL COMPUTER NETWORK (U.S. CLS. 100 AND 101).

FIRST USE 5-1-2011; IN COMMERCE 5-1-2011.

4,119,064. CUNNINGHAM, ARGUS I., FPO AE, ITALY. SN 85-002,232. PUB. 8-31-2010, FILED 3-30-2010.

SHARE ASK

THE MARK CONSISTS OF STANDARD CHARACTERS WITHOUT CLAIM TO ANY PARTICULAR FONT, STYLE, SIZE, OR COLOR.

NO CLAIM IS MADE TO THE EXCLUSIVE RIGHT TO USE "SHARE", APART FROM THE MARK AS SHOWN.

FOR PROVIDING A WEBSITE FEATURING TECHNOLOGY THAT FACILITATES SHAREHOLDERS' ELECTRONIC COMMUNICATION AND SOCIAL MEDIA INTERACTION FOR THE PURPOSE OF IMPROVING CORPORATE GOVERNANCE OVERSIGHT; PROVIDING ON-LINE NON-DOWNLOADABLE SOFTWARE THAT FACILITATES SHAREHOLDERS' ELECTRONIC COMMUNICATION AND SOCIAL MEDIA INTERACTION FOR THE PURPOSE OF IMPROVING CORPORATE GOVERNANCE OVERSIGHT (U.S. CLS. 100 AND 101).

FIRST USE 11-30-2010; IN COMMERCE 11-30-2011.

4,119,065. CUNNINGHAM, ARGUS I., FPO AE, ITALY. SN 85-002,294. PUB. 8-31-2010, FILED 3-30-2010.

SHARE ACTION

THE MARK CONSISTS OF STANDARD CHARACTERS WITHOUT CLAIM TO ANY PARTICULAR FONT, STYLE, SIZE, OR COLOR.

CLASS 42—(Continued).

NO CLAIM IS MADE TO THE EXCLUSIVE RIGHT TO USE "SHARE", APART FROM THE MARK AS SHOWN.

FOR PROVIDING A WEBSITE FEATURING TECHNOLOGY THAT FACILITATES SHAREHOLDERS' ELECTRONIC COMMUNICATION AND SOCIAL MEDIA INTERACTION FOR THE PURPOSE OF IMPROVING CORPORATE GOVERNANCE OVERSIGHT; PROVIDING ON-LINE NON-DOWNLOADABLE SOFTWARE THAT FACILITATES SHAREHOLDERS' ELECTRONIC COMMUNICATION AND SOCIAL MEDIA INTERACTION FOR THE PURPOSE OF IMPROVING CORPORATE GOVERNANCE OVERSIGHT (U.S. CLS. 100 AND 101).

FIRST USE 11-30-2010; IN COMMERCE 11-30-2011.

4,119,082. NEBRASKA BOOK COMPANY, INC., LINCOLN, NE. SN 85-021,123. PUB. 8-17-2010, FILED 4-22-2010.

NEEBO

THE MARK CONSISTS OF STANDARD CHARACTERS WITHOUT CLAIM TO ANY PARTICULAR FONT, STYLE, SIZE, OR COLOR.

THE WORD "NEEBO" HAS NO MEANING IN A FOREIGN LANGUAGE.

FOR PLANNING AND DESIGNING COLLEGE BOOKSTORES; INTERNET WEBSITE HOSTING SERVICES (U.S. CLS. 100 AND 101).

FIRST USE 1-15-2010; IN COMMERCE 1-15-2010.

4,119,137. OPTIONS & CHOICES, INC., GREENWOOD VILLAGE, CO. SN 85-055,480. PUB. 11-30-2010, FILED 6-4-2010.

LeaveXpert

THE MARK CONSISTS OF STANDARD CHARACTERS WITHOUT CLAIM TO ANY PARTICULAR FONT, STYLE, SIZE, OR COLOR.

FOR APPLICATION SERVICE PROVIDER (ASP) FEATURING NON-DOWNLOADABLE COMPUTER SOFTWARE FOR STORING, INTEGRATING, EVALUATING, ANALYZING, MANIPULATING AND REPORTING DATA AND INFORMATION IN THE FIELD OF HUMAN RESOURCE MANAGEMENT (U.S. CLS. 100 AND 101).

FIRST USE 6-0-2010; IN COMMERCE 6-0-2010.

CLASS 42—(Continued).

4,119,203. ALANDA LLC, SCOTCH PLAINS, NJ. SN 85-090,378. PUB. 1-11-2011, FILED 7-22-2010.

CONSUMMATE

THE MARK CONSISTS OF STANDARD CHARACTERS WITHOUT CLAIM TO ANY PARTICULAR FONT, STYLE, SIZE, OR COLOR.

FOR SOFTWARE AS A SERVICE (SAAS) SERVICES, NAMELY, HOSTING SOFTWARE FOR USE BY OTHERS FOR USE IN AGGREGATE SPEND TRACKING AND MANAGEMENT (U.S. CLS. 100 AND 101).

FIRST USE 7-0-2010; IN COMMERCE 7-0-2010.

4,119,214. REAL ESTATE IRA UNIVERSITY, INC., GOLDEN, CO. SN 85-096,766. PUB. 12-21-2010, FILED 7-30-2010.

GRIU

THE MARK CONSISTS OF STANDARD CHARACTERS WITHOUT CLAIM TO ANY PARTICULAR FONT, STYLE, SIZE, OR COLOR.

FOR ACCREDITATION SERVICES, NAMELY, SETTING AND PROVIDING STANDARDS FOR REAL ESTATE IRA PROFESSIONALS FOR THE PURPOSE OF ACCREDITATION (U.S. CLS. 100 AND 101).

FIRST USE 9-1-2010; IN COMMERCE 9-1-2010.

4,119,245. GEARTRIBE CORP, ORINDA, CA. SN 85-120,305. PUB. 2-15-2011, FILED 8-31-2010.

GEARTRIBE

THE MARK CONSISTS OF STANDARD CHARACTERS WITHOUT CLAIM TO ANY PARTICULAR FONT, STYLE, SIZE, OR COLOR.

FOR PROVIDING A WEBSITE FEATURING TECHNOLOGY THAT ENABLES USERS TO MAKE COLLECTIVE PURCHASES TO ACQUIRE DISCOUNTS FOR VARIOUS GOODS AND SERVICES (U.S. CLS. 100 AND 101).

FIRST USE 5-1-2011; IN COMMERCE 8-29-2011.

CLASS 42—(Continued).

4,119,259. INCONTACT, MIDVALE, UT. SN 85-128,411. PUB. 8-23-2011, FILED 9-13-2010.

INCLOUD

THE MARK CONSISTS OF STANDARD CHARACTERS WITHOUT CLAIM TO ANY PARTICULAR FONT, STYLE, SIZE, OR COLOR.

FOR APPLICATION SERVICE PROVIDER FEATURING SOFTWARE FOR QUEUING, HANDLING, LOGGING, RECORDING, MONITORING, TRACKING, SUPERVISING, MANAGING, ROUTING, DISPOSITION AND DISTRIBUTION OF TELEPHONE CALLS, FACSIMILE TRANSMISSIONS, EMAILS, SOCIAL MEDIA, AND WEB BASED MESSAGES TO OR FROM IN OFFICE OR AT HOME EMPLOYEES, CONTRACTORS, SUBCONTRACTORS, PARTIES, CALLERS OR CUSTOMERS FOR USE IN THE FIELD OF CUSTOMER SERVICE, CUSTOMER SUPPORT, INSIDE SALES, COLLECTIONS, OUTSIDE SALES, AND MARKETING. APPLICATION SERVICE PROVIDER FEATURING SOFTWARE FOR SCHEDULING, SURVEYING, MONITORING, SUPERVISING, RATING, REVIEWING MANAGING, FORECASTING, RECORDING, ANALYZING AND TRAINING EMPLOYEES FOR USE IN THE FIELD OF CUSTOMER SERVICE, CUSTOMER SUPPORT, INSIDE SALES, COLLECTIONS, OUTSIDE SALES, AND MARKETING. APPLICATION SERVICE PROVIDER FEATURING AN APPLICATION SOFTWARE DEVELOPMENT TOOL FOR USE IN CUSTOMIZING TELECOMMUNICATION SERVICE APPLICATIONS, NAMELY, SOFTWARE FOR QUEUING, HANDLING, LOGGING, RECORDING, MONITORING, TRACKING, SUPERVISING, MANAGING, ROUTING, DISPOSITION AND DISTRIBUTION OF TELEPHONE CALLS, FACSIMILE TRANSMISSIONS, EMAILS, SOCIAL MEDIA, AND WEB BASED MESSAGES TO OR FROM IN OFFICE OR AT HOME EMPLOYEES, CONTRACTORS, SUBCONTRACTORS, PARTIES, CALLERS OR CUSTOMERS FOR USE IN THE FIELD OF CUSTOMER SERVICE, CUSTOMER SUPPORT, INSIDE SALES, COLLECTIONS, OUTSIDE SALES, AND MARKETING (U.S. CLS. 100 AND 101).

FIRST USE 5-30-2011; IN COMMERCE 5-30-2011.

4,119,324. A2SIX, INC., LISLE, IL. SN 85-176,611. PUB. 5-24-2011, FILED 11-15-2010.



THE COLOR(S) BLACK, AND RED IS/ARE CLAIMED AS A FEATURE OF THE MARK.

CLASS 42—(Continued).

THE MARK CONSISTS OF BLACK LETTERING OF LITERAL ELEMENT "A2SIX", RED LETTERING OF LITERAL ELEMENT "DISCOVER WHAT'S RELEVANT", RED AND SHADES OF RED ON A STYLIZED DESIGN THAT SUGGESTS THE FORM OF A SAIL OR PART OF A GLOBE OR SPHERE.

FOR CONDUCTING ELECTRONIC DISCOVERY SERVICES VIA GLOBAL COMPUTER NETWORKS FOR LAWYERS AND CORPORATIONS; CONVERSION OF DATA OR DOCUMENTS FROM PHYSICAL TO ELECTRONIC MEDIA; DATA AUTOMATION AND COLLECTION SERVICE USING PROPRIETARY SOFTWARE TO EVALUATE, ANALYZE AND COLLECT SERVICE DATA; DATA CONVERSION OF ELECTRONIC INFORMATION; ELECTRONIC LEGAL DISCOVERY CONSULTING SERVICES; ELECTRONIC SCANNING OF DOCUMENTS FOR DOCUMENT REVIEW, INDEXING, CONSULTING AND E-DISCOVERY FOR BUSINESSES AND LAW FIRMS. IT CONSULTING SERVICES; PLATFORM AS A SERVICE (PAAS) FEATURING COMPUTER SOFTWARE PLATFORMS FOR DOCUMENT REVIEW AND INDEXING. PROVIDING AN ONLINE NETWORK SERVICE THAT ENABLES USERS TO SHARE DATA IN THE FIELD OF E-DISCOVERY FOR BUSINESS AND LAW FIRMS (U.S. CLS. 100 AND 101).

FIRST USE 11-1-2010; IN COMMERCE 2-21-2011.

4,119,329. LANDAUER, INC., GLENWOOD, IL. SN 85-178,641. PUB. 4-12-2011, FILED 11-17-2010.

RADLIGHT

THE MARK CONSISTS OF STANDARD CHARACTERS WITHOUT CLAIM TO ANY PARTICULAR FONT, STYLE, SIZE, OR COLOR.

FOR MEASUREMENT EVALUATIONS IN THE PERSONNEL RADIATION DOSIMETRY FIELD (U.S. CLS. 100 AND 101).

FIRST USE 9-20-2010; IN COMMERCE 8-0-2011.

4,119,330. LANDAUER, INC., GLENWOOD, IL. SN 85-178,800. PUB. 4-12-2011, FILED 11-17-2010.

RADWATCH

THE MARK CONSISTS OF STANDARD CHARACTERS WITHOUT CLAIM TO ANY PARTICULAR FONT, STYLE, SIZE, OR COLOR.

FOR MEASUREMENT EVALUATIONS IN THE PERSONNEL RADIATION DOSIMETRY FIELD (U.S. CLS. 100 AND 101).

FIRST USE 9-20-2010; IN COMMERCE 8-0-2011.

CLASS 42—(Continued).

4,119,384. CENTENE CORPORATION, ST. LOUIS, MO. SN 85-197,334. PUB. 5-3-2011, FILED 12-14-2010.

CENTELLIGENCE

THE MARK CONSISTS OF STANDARD CHARACTERS WITHOUT CLAIM TO ANY PARTICULAR FONT, STYLE, SIZE, OR COLOR.

FOR PROVIDING TEMPORARY USE OF ON-LINE NON-DOWNLOADABLE SOFTWARE FOR USE IN THE MANAGEMENT OF MEDICAL INFORMATION IN THE HEALTH CARE FIELD (U.S. CLS. 100 AND 101).

FIRST USE 12-15-2011; IN COMMERCE 12-15-2011.

4,119,400. SPRING WIRELESS USA, INC., SEATTLE, WA. SN 85-199,863. PUB. 5-3-2011, FILED 12-16-2010.

BECAUSE BUSINESS MOVES.

THE MARK CONSISTS OF STANDARD CHARACTERS WITHOUT CLAIM TO ANY PARTICULAR FONT, STYLE, SIZE, OR COLOR.

FOR APPLICATION SERVICE PROVIDER, NAMELY, PROVIDING, HOSTING, MANAGING, DEVELOPING, AND MAINTAINING APPLICATIONS IN THE FIELDS OF WIRELESS COMMUNICATION, CUSTOMER RELATIONSHIP MANAGEMENT, MOBILE INFORMATION ACCESS, AND REMOTE DATA MANAGEMENT FOR WIRELESS DELIVERY OF CONTENT TO MOBILE ELECTRONIC DEVICES (U.S. CLS. 100 AND 101).

FIRST USE 11-0-2008; IN COMMERCE 11-0-2008.

4,119,430. LUA TECHNOLOGIES, LLC, WILMINGTON, DE. SN 85-205,853. PUB. 5-17-2011, FILED 12-27-2010.

LUA TECHNOLOGIES

THE MARK CONSISTS OF STANDARD CHARACTERS WITHOUT CLAIM TO ANY PARTICULAR FONT, STYLE, SIZE, OR COLOR.

CLASS 42—(Continued).

NO CLAIM IS MADE TO THE EXCLUSIVE RIGHT TO USE "TECHNOLOGIES", APART FROM THE MARK AS SHOWN.

FOR SOFTWARE AS A SERVICE (SAAS) SERVICES FEATURING SOFTWARE FOR MANAGING FILM PRODUCTION PROCESSES, CREATING, DOCUMENTING, SHARING AND ARCHIVING FILM PROJECTS, DATA MINING AND FOR COLLECTING, EDITING, ORGANIZING, MODIFYING, BOOKMARKING, TRANSMISSION, STORAGE AND SHARING OF DATA AND INFORMATION FOR USE IN ASSISTING WITH FILM PRODUCTION (U.S. CLS. 100 AND 101).

FIRST USE 2-1-2010; IN COMMERCE 9-1-2010.

4,119,443. JOURNELLA, LLC, WILLIAMSBURG, VA. SN 85-209,902. PUB. 5-3-2011, FILED 1-4-2011.

Journella

THE MARK CONSISTS OF STANDARD CHARACTERS WITHOUT CLAIM TO ANY PARTICULAR FONT, STYLE, SIZE, OR COLOR.

FOR COMPUTER SERVICES, NAMELY, HOSTING ONLINE WEB FACILITIES FOR OTHERS FOR ORGANIZING PERSONAL INFORMATION, AUDIO RECORDINGS, IMAGES, VIDEOS, AND MULTIMEDIA; COMPUTER SERVICES, NAMELY, HOSTING AN ONLINE COMMUNITY WHERE USERS MAY INTERACT, SHARE INFORMATION, FORM VIRTUAL COMMUNITIES, AND ENGAGE IN SOCIAL AND BUSINESS NETWORKING (U.S. CLS. 100 AND 101).

FIRST USE 5-13-2011; IN COMMERCE 5-13-2011.

4,119,469. L1 TECHNOLOGIES, INC., SAN DIEGO, CA. SN 85-216,373. PUB. 7-19-2011, FILED 1-12-2011.

IGOLF SWING

THE MARK CONSISTS OF STANDARD CHARACTERS WITHOUT CLAIM TO ANY PARTICULAR FONT, STYLE, SIZE, OR COLOR.

OWNER OF U.S. REG. NOS. 3,451,915, 3,491,055, AND 3,932,160.

NO CLAIM IS MADE TO THE EXCLUSIVE RIGHT TO USE "SWING", APART FROM THE MARK AS SHOWN.

FOR PROVIDING A WEBSITE THAT GIVES COMPUTER USERS THE ABILITY TO UPLOAD PHOTOS, AND VIDEO OF GOLF SWINGS TO COMPARE AND ANALYZE THE USER'S GOLF SWING (U.S. CLS. 100 AND 101).

FIRST USE 2-25-2011; IN COMMERCE 2-25-2011.

CLASS 42—(Continued).

4,119,472. EYEME, LLC, HOUSTON, TX. SN 85-217,512. PUB. 5-24-2011, FILED 1-13-2011.

eyeMe

THE MARK CONSISTS OF STANDARD CHARACTERS WITHOUT CLAIM TO ANY PARTICULAR FONT, STYLE, SIZE, OR COLOR.

FOR APPLICATION SERVICE PROVIDER (ASP) FEATURING SOFTWARE FOR USE TO ENABLE OR FACILITATE THE UPLOADING, DOWNLOADING, STREAMING, POSTING, DISPLAYING, BLOGGING, LINKING, SHARING OR OTHERWISE PROVIDING ELECTRONIC MEDIA OR INFORMATION OVER COMMUNICATION NETWORKS; COMPUTER SERVICES, NAMELY, CREATING AN ON-LINE COMMUNITY FOR REGISTERED USERS TO PARTICIPATE IN DISCUSSIONS, GET FEEDBACK FROM THEIR PEERS, FORM VIRTUAL COMMUNITIES, AND ENGAGE IN SOCIAL NETWORKING; PEER-TO-BROWSER PHOTO SHARING SERVICES, NAMELY, PROVIDING A WEBSITE FEATURING TECHNOLOGY ENABLING USERS TO UPLOAD, VIEW, AND DOWNLOAD DIGITAL PHOTOS; PROVIDING A WEB SITE FEATURING TEMPORARY USE OF NON-DOWNLOADABLE SOFTWARE ALLOWING WEB SITE USERS TO UPLOAD, POST AND DISPLAY ONLINE VIDEOS FOR SHARING WITH OTHERS FOR ENTERTAINMENT PURPOSES; PROVIDING A WEBSITE THAT GIVES USERS THE ABILITY TO CREATE CUSTOMIZED WEB PAGES FEATURING USER-DEFINED PROFILES (U.S. CLS. 100 AND 101).

FIRST USE 1-18-2012; IN COMMERCE 1-18-2012.

4,119,529. APP CUISINE, LLC, CARY, NC. SN 85-235,195. PUB. 7-12-2011, FILED 2-6-2011.

App Cuisine

THE MARK CONSISTS OF STANDARD CHARACTERS WITHOUT CLAIM TO ANY PARTICULAR FONT, STYLE, SIZE, OR COLOR.

NO CLAIM IS MADE TO THE EXCLUSIVE RIGHT TO USE "APP", APART FROM THE MARK AS SHOWN.

FOR COMPUTER SOFTWARE CONSULTING; COMPUTER SOFTWARE DEVELOPMENT AND COMPUTER PROGRAMMING DEVELOPMENT FOR OTHERS; COMPUTER SOFTWARE DEVELOPMENT IN THE FIELD OF MOBILE APPLICATIONS; CUSTOMIZED SOFTWARE DEVELOPMENT SERVICES; DESIGN, DEVELOPMENT, INSTALLATION AND MAINTENANCE OF COMPUTER SOFTWARE; DESIGNING AND DEVELOPING WEB-PAGES ON THE INTERNET; PROVIDING AN INTERNET WEBSITE PORTAL IN THE FIELDS OF TECHNOLOGY AND SOFTWARE DEVELOPMENT; WEBSITE DESIGN AND DEVELOPMENT FOR OTHERS (U.S. CLS. 100 AND 101).

FIRST USE 1-31-2011; IN COMMERCE 2-9-2011.

CLASS 42—(Continued).

4,119,555. BECTON, DICKINSON AND COMPANY, FRANKLIN LAKES, NJ. SN 85-248,498. PUB. 6-7-2011, FILED 2-22-2011.

BD FACSelect

THE MARK CONSISTS OF STANDARD CHARACTERS WITHOUT CLAIM TO ANY PARTICULAR FONT, STYLE, SIZE, OR COLOR.

OWNER OF U.S. REG. NOS. 2,510,232, 2,996,913, AND OTHERS.

FOR WEB-BASED TOOLS IN THE NATURE OF AN ONLINE SEARCH ENGINE FOR OBTAINING INFORMATION ABOUT RESEARCH REAGENTS FOR MULTICOLOR FLOW CYTOMETRY EXPERIMENTS (U.S. CLS. 100 AND 101).

FIRST USE 5-30-2011; IN COMMERCE 5-30-2011.

4,119,592. TOTALCAD COMERCIO E SERVIÇOS EM INFORMATICA LTDA, SAO PAULO, BRAZIL. SN 85-266,252. PUB. 8-9-2011, FILED 3-14-2011.

totalCAD

THE COLOR(S) GRAY AND ORANGE IS/ARE CLAIMED AS A FEATURE OF THE MARK.

THE MARK CONSISTS OF THE WORD, "TOTAL", IN LOWERCASE GRAY LETTERING, IMMEDIATELY ADJACENT TO THE WORD, "CAD", IN UPPERCASE ORANGE LETTERING. THE COLOR WHITE IS MERE BACKGROUND AND IS NOT CLAIMED AS A FEATURE OF THE MARK.

FOR SOFTWARE DEVELOPMENT AND PRODUCT DEVELOPMENT IN THE FIELD OF SOFTWARE SOLUTIONS FOR TECHNICAL PROJECTS, ENGINEERING, ARCHITECTURE AND INDUSTRIAL PROJECTS (U.S. CLS. 100 AND 101).

FIRST USE 1-1-2010; IN COMMERCE 1-1-2011.

CLASS 42—(Continued).

4,119,616. MYVOICE, INC., TORONTO, ONTARIO, CANADA. SN 85-283,235. PUB. 9-6-2011, FILED 3-31-2011.

MYVOICE

THE MARK CONSISTS OF STANDARD CHARACTERS WITHOUT CLAIM TO ANY PARTICULAR FONT, STYLE, SIZE, OR COLOR.

FOR APPLICATION SERVICE PROVIDER, NAMELY, PROVIDING MOBILE DEVICE-BASED, WEB-BASED, AND WIRELESS INTERNET-BASED AUGMENTATIVE AND ALTERNATIVE COMMUNICATION SOFTWARE APPLICATIONS FOR PEOPLE WITH SPEECH AND LANGUAGE IMPAIRMENTS (U.S. CLS. 100 AND 101).
FIRST USE 11-28-2010; IN COMMERCE 4-5-2011.

4,119,638. PARTICLE SCIENCES, INC., BETHLEHEM, PA. SN 85-295,245. PUB. 8-23-2011, FILED 4-14-2011.

WE DELIVER

THE MARK CONSISTS OF STANDARD CHARACTERS WITHOUT CLAIM TO ANY PARTICULAR FONT, STYLE, SIZE, OR COLOR.

FOR PHARMACEUTICAL DRUG DEVELOPMENT SERVICES (U.S. CLS. 100 AND 101).
FIRST USE 10-15-2011; IN COMMERCE 10-15-2011.

4,119,656. NOVEX NOVICE TO EXPERT LEARNING, LLC, ST. LOUIS, MO. SN 85-306,944. PUB. 9-13-2011, FILED 4-28-2011.

NOVEX

THE MARK CONSISTS OF STANDARD CHARACTERS WITHOUT CLAIM TO ANY PARTICULAR FONT, STYLE, SIZE, OR COLOR.

FOR PROVIDING TEMPORARY USE OF NONDOWNLOADABLE SOFTWARE THAT ENABLES USERS TO ACCESS INTERACTIVE TRAINING SIMULATIONS TO ENHANCE VOCATIONAL AND PROFESSIONAL DEVELOPMENT (U.S. CLS. 100 AND 101).
FIRST USE 4-0-2011; IN COMMERCE 4-0-2011.

CLASS 42—(Continued).

4,119,672. MIDLIFE COLLAGE, LLC, LAS VEGAS, NV. SN 85-317,431. PUB. 10-4-2011, FILED 5-10-2011.

MIDLIFE COLLAGE

THE MARK CONSISTS OF STANDARD CHARACTERS WITHOUT CLAIM TO ANY PARTICULAR FONT, STYLE, SIZE, OR COLOR.

FOR APPLICATION SERVICE PROVIDER (ASP) FEATURING SOFTWARE ENABLING THE UPLOADING AND TRANSMISSION OF ELECTRONIC MEDIA OR INFORMATION OVER THE INTERNET OR OTHER COMMUNICATIONS NETWORKS AND FOR RATING AND POSTING COMMENTS ON USER-GENERATED CONTENT; COMPUTER SERVICES, NAMELY, HOSTING ONLINE WEB FACILITIES FOR OTHERS TO SHOWCASE CREATIVE TALENTS AND FOR FACILITATING ONLINE CONNECTIONS, INTERACTIVE DISCUSSIONS, COMMENTARY AND RATING OF USER-GENERATED CONTENT AND SOCIAL, BUSINESS AND COMMUNITY NETWORKING; COMPUTER SERVICES, NAMELY, CREATING ON-LINE VIRTUAL COMMUNITIES FOR OTHERS TO SHOWCASE CREATIVE TALENTS AND FOR FACILITATING ONLINE CONNECTIONS, INTERACTIVE DISCUSSIONS, COMMENTARY AND RATING OF USER-GENERATED CONTENT AND SOCIAL, BUSINESS AND COMMUNITY NETWORKING; PROVIDING A WEB SITE THAT GIVES USERS THE ABILITY TO UPLOAD AND POTENTIALLY SHARE USER-GENERATED PROSE ON A WIDE VARIETY OF TOPICS AND SUBJECTS (U.S. CLS. 100 AND 101).

FIRST USE 8-1-2011; IN COMMERCE 8-1-2011.

4,119,677. U-MATCH, LLC, DBA ROOMBUG, PLANTATION, FL. SN 85-320,845. PUB. 11-1-2011, FILED 5-13-2011.



THE MARK CONSISTS OF THE TERM "ROOMSYNC" TO THE RIGHT OF TWO CURVED ARROWS ENCIRCLING THE SILHOUETTE OF TWO PERSONS.

FOR PROVIDING A WEB-BASED SERVICE WHICH ALLOWS USERS TO SELECT RESIDENCE ROOMMATES BASED ON PERSONAL PROFILE DATA PROVIDED ONLINE (U.S. CLS. 100 AND 101).
FIRST USE 7-7-2011; IN COMMERCE 7-7-2011.

CLASS 42—(Continued).

4,119,725. APPSOLUTE MADNESS, INC., HOUSTON, TX. SN 85-976,228. PUB. 5-24-2011, FILED 10-26-2010.

BOTL

THE MARK CONSISTS OF STANDARD CHARACTERS WITHOUT CLAIM TO ANY PARTICULAR FONT, STYLE, SIZE, OR COLOR.

FOR PROVIDING TEMPORARY USE OF ON-LINE NON-DOWNLOADABLE SOFTWARE FOR TRANSMITTING, STORING AND RECEIVING MEDIA CONTENT, INCLUDING VIDEO AND IMAGES, IN THE FIELD OF COMMUNICATIONS AND MUSICAL AND LITERARY ENTERTAINMENT (U.S. CLS. 100 AND 101).

FIRST USE 12-22-2011; IN COMMERCE 12-22-2011.

CLASS 43—HOTEL AND RESTAURANT SERVICES

4,118,851. MODERN MEXICAN RESTAURANTS, INC., DENVER, CO. SN 77-498,483. PUB. 11-25-2008, FILED 6-13-2008.

TORO TORO

THE MARK CONSISTS OF STANDARD CHARACTERS WITHOUT CLAIM TO ANY PARTICULAR FONT, STYLE, SIZE, OR COLOR.

THE FOREIGN WORDING IN THE MARK TRANSLATES INTO ENGLISH AS "BULL BULL".

FOR RESTAURANT AND COCKTAIL BAR SERVICES (U.S. CLS. 100 AND 101).

FIRST USE 8-12-2011; IN COMMERCE 8-12-2011.

4,118,945. US AIRWAYS, INC., TEMPE, AZ. SN 77-835,400. PUB. 9-7-2010, FILED 9-25-2009.

US AIRWAYS MARKETPLACE

THE MARK CONSISTS OF STANDARD CHARACTERS WITHOUT CLAIM TO ANY PARTICULAR FONT, STYLE, SIZE, OR COLOR.

OWNER OF U.S. REG. NOS. 2,261,360, 2,931,571, AND OTHERS.

NO CLAIM IS MADE TO THE EXCLUSIVE RIGHT TO USE "AIRWAYS MARKETPLACE", APART FROM THE MARK AS SHOWN.

CLASS 43—(Continued).

SEC. 2(F) AS TO "US AIRWAYS".

FOR CATERING FOR THE PROVISION OF FOOD AND BEVERAGES (U.S. CLS. 100 AND 101).

FIRST USE 9-1-2009; IN COMMERCE 9-1-2009.

4,118,954. BASMAN A. METTI, MORTON GROVE, IL. SN 77-854,188. PUB. 4-26-2011, FILED 10-21-2009.

J.WELLINGTON'S

THE MARK CONSISTS OF STANDARD CHARACTERS WITHOUT CLAIM TO ANY PARTICULAR FONT, STYLE, SIZE, OR COLOR.

THE NAME "J. WELLINGTON'S" DOES NOT IDENTIFY A LIVING INDIVIDUAL.

FOR RESTAURANT SERVICES (U.S. CLS. 100 AND 101).

FIRST USE 3-10-2010; IN COMMERCE 3-10-2010.

4,119,077. BLUE LEMON LLC, ALPINE, UT. SN 85-016,282. PUB. 6-15-2010, FILED 4-16-2010.

BLUE LEMON

THE MARK CONSISTS OF STANDARD CHARACTERS WITHOUT CLAIM TO ANY PARTICULAR FONT, STYLE, SIZE, OR COLOR.

FOR PROVIDING SOCIAL MEETING, BANQUET AND SOCIAL FUNCTION FACILITIES; CATERING SERVICES (U.S. CLS. 100 AND 101).

FIRST USE 5-0-2008; IN COMMERCE 2-0-2009.

4,119,198. CLAUDIUS P., SAN JOSE, CA. SN 85-088,079. PUB. 5-31-2011, FILED 7-19-2010.

YOGURT COVE

THE MARK CONSISTS OF STANDARD CHARACTERS WITHOUT CLAIM TO ANY PARTICULAR FONT, STYLE, SIZE, OR COLOR.

CLASS 43—(Continued).

NO CLAIM IS MADE TO THE EXCLUSIVE RIGHT TO USE "YOGURT", APART FROM THE MARK AS SHOWN.

FOR RESTAURANT SERVICES FEATURING FROZEN YOGURT WITH ASSORTED TOPPINGS; TAKE OUT RESTAURANT SERVICES FEATURING FROZEN YOGURT WITH ASSORTED TOPPINGS (U.S. CLS. 100 AND 101).

FIRST USE 3-20-2011; IN COMMERCE 5-25-2011.

CLASS 43—(Continued).

4,119,238. STARWOOD HOTELS & RESORTS WORLDWIDE, INC., WHITE PLAINS, NY. SN 85-113,175. PUB. 5-31-2011, FILED 8-23-2010.

4,119,223. BLUE RIBBON IP, LLC, NEW YORK, NY. SN 85-103,428. PUB. 6-21-2011, FILED 8-9-2010.

CHEFS TO THE CHEFS

THE MARK CONSISTS OF STANDARD CHARACTERS WITHOUT CLAIM TO ANY PARTICULAR FONT, STYLE, SIZE, OR COLOR.

NO CLAIM IS MADE TO THE EXCLUSIVE RIGHT TO USE "CHEFS", APART FROM THE MARK AS SHOWN.

FOR CONSULTANCY SERVICES IN THE FIELD OF MENU PLANNING FOR OTHERS; CONSULTATION SERVICES IN THE FIELD OF RESTAURANT MENU DEVELOPMENT; CONSULTING SERVICES IN THE FIELD OF CULINARY ARTS; CONSULTING SERVICES IN THE FIELD OF HOSPITALITY (U.S. CLS. 100 AND 101).

FIRST USE 12-7-2011; IN COMMERCE 12-7-2011.

4,119,224. MCGUIRE, PAULA T., LEXINGTON, KY. SN 85-103,726. PUB. 1-25-2011, FILED 8-10-2010.

Fro-Jo's

THE MARK CONSISTS OF STANDARD CHARACTERS WITHOUT CLAIM TO ANY PARTICULAR FONT, STYLE, SIZE, OR COLOR.

FOR FROZEN YOGURT SHOP SERVICES IN THE NATURE OF A RESTAURANT (U.S. CLS. 100 AND 101). FIRST USE 9-30-2010; IN COMMERCE 9-30-2010.

MORE LUXURY MORE DESTINATIONS

THE MARK CONSISTS OF STANDARD CHARACTERS WITHOUT CLAIM TO ANY PARTICULAR FONT, STYLE, SIZE, OR COLOR.

FOR HOTEL SERVICES; HOTEL SERVICES FEATURING A GUEST AWARD PROGRAM FOR GUESTS (U.S. CLS. 100 AND 101).

FIRST USE 1-0-2011; IN COMMERCE 1-0-2011.

4,119,305. LMA FOOD CONCEPTS, S.C., GARZA GARCIA N.L., MEXICO. SN 85-159,686. PUB. 3-22-2011, FILED 10-23-2010.



Lazaranda
Mexican Seafood Grill

NO CLAIM IS MADE TO THE EXCLUSIVE RIGHT TO USE "MEXICAN SEAFOOD GRILL", APART FROM THE MARK AS SHOWN.

THE MARK CONSISTS OF A RING INSIDE OF WHICH APPEARS ANOTHER THICKER RING OVER WHICH APPEARS THE WORDING "LAZARANDA MEXICAN SEAFOOD GRILL" IN STYLIZED LETTERS. INSIDE OF THE THICKER RING A APPEARS A CIRCLE INSIDE OF WHICH APPEARS AN ABSTRACT FIGURE SIMILAR TO A STYLIZED LETTER "Z". BELOW THE DESCRIBED DESIGN APPEARS THE WORDING "LAZARANDA MEXICAN SEAFOOD GRILL" IN STYLIZED LETTERS.

THE WORDING "LAZARANDA" HAS NO MEANING IN A FOREIGN LANGUAGE.

FOR RESTAURANT SERVICES; SERVING FOOD AND DRINKS (U.S. CLS. 100 AND 101).

FIRST USE 11-1-2011; IN COMMERCE 11-1-2011.

CLASS 43—(Continued).

4,119,409. MODERN APIZZA, INC., NEW HAVEN, CT. SN 85-201,746. PUB. 4-26-2011, FILED 12-20-2010.



THE MARK CONSISTS OF A STYLIZED LETTER "M" CONTAINED WITHIN A CIRCULAR DESIGN.
FOR RESTAURANT SERVICES (U.S. CLS. 100 AND 101).
FIRST USE 3-2-2001; IN COMMERCE 3-2-2001.

4,119,470. JAKE'S JOINT, INC., RICHARDSON, TX. SN 85-217,184. PUB. 5-10-2011, FILED 1-13-2011.



NO CLAIM IS MADE TO THE EXCLUSIVE RIGHT TO USE "JOINT", APART FROM THE MARK AS SHOWN.
THE COLOR(S) BLACK AND YELLOW IS/ARE CLAIMED AS A FEATURE OF THE MARK.
THE MARK CONSISTS OF THE PHRASE "JAKE'S JOINT" IN BLACK, WITH SHADOW LETTERING IN YELLOW. UNDER THE PHRASE "JAKE'S JOINT" IS A YELLOW BANNER OUTLINED IN BLACK BEARING THE PHRASE "FOOD FIT FOR A KING" IN BLACK.
FOR RESTAURANT AND BAR SERVICES (U.S. CLS. 100 AND 101).
FIRST USE 5-16-2011; IN COMMERCE 5-16-2011.

4,119,483. EXPEDIA, INC., BELLEVUE, WA. SN 85-221,582. PUB. 5-17-2011, FILED 1-19-2011.

EXPEDIA ASAP

THE MARK CONSISTS OF STANDARD CHARACTERS WITHOUT CLAIM TO ANY PARTICULAR FONT, STYLE, SIZE, OR COLOR.

CLASS 43—(Continued).

OWNER OF U.S. REG. NOS. 2,220,719, 2,612,384, AND 3,704,230.

FOR TRAVEL AGENCY SERVICES, NAMELY, MAKING RESERVATIONS AND BOOKINGS FOR TEMPORARY ACCOMMODATIONS; HOTEL AND LODGING SERVICES, NAMELY, PROVIDING AND RELAYING INFORMATION IN CONNECTION WITH RESERVATIONS AND BOOKINGS FOR TEMPORARY LODGING AND PROVIDING REVIEWS OF HOTELS BY MEANS OF A TELEPHONE, AND OVER COMPUTER NETWORKS AND GLOBAL COMMUNICATION NETWORKS; PROVIDING A WEBSITE WHERE USERS CAN POST RATINGS, REVIEWS AND RECOMMENDATIONS ON EVENTS AND ACTIVITIES IN THE FIELD OF TEMPORARY LODGING; PROVIDING ADVICE TO TOURISTS AND BUSINESS TRAVELERS ON TEMPORARY LODGING AND RESTAURANT DESTINATIONS (U.S. CLS. 100 AND 101).

FIRST USE 2-16-2011; IN COMMERCE 2-16-2011.

4,119,484. EXPEDIA, INC., BELLEVUE, WA. SN 85-221,586. PUB. 5-17-2011, FILED 1-19-2011.

ASAP A SUDDEN AMAZING PRICE

THE MARK CONSISTS OF STANDARD CHARACTERS WITHOUT CLAIM TO ANY PARTICULAR FONT, STYLE, SIZE, OR COLOR.

FOR TRAVEL AGENCY SERVICES, NAMELY, MAKING RESERVATIONS AND BOOKINGS FOR TEMPORARY ACCOMMODATIONS; HOTEL AND LODGING SERVICES, NAMELY, PROVIDING AND RELAYING INFORMATION IN CONNECTION WITH RESERVATIONS AND BOOKINGS FOR TEMPORARY LODGING AND PROVIDING REVIEWS OF HOTELS BY MEANS OF A TELEPHONE, AND OVER COMPUTER NETWORKS AND GLOBAL COMMUNICATION NETWORKS; PROVIDING A WEBSITE WHERE USERS CAN POST RATINGS, REVIEWS AND RECOMMENDATIONS ON EVENTS AND ACTIVITIES IN THE FIELD OF TEMPORARY LODGING; PROVIDING ADVICE TO TOURISTS AND BUSINESS TRAVELERS ON TEMPORARY LODGING AND RESTAURANT DESTINATIONS (U.S. CLS. 100 AND 101).

FIRST USE 2-16-2011; IN COMMERCE 2-16-2011.

4,119,508. BUSKELL, WILLIAM, PANAMA CITY BEACH, FL. SN 85-227,751. PUB. 5-31-2011, FILED 1-27-2011.

THE WICKED WHEEL

THE MARK CONSISTS OF STANDARD CHARACTERS WITHOUT CLAIM TO ANY PARTICULAR FONT, STYLE, SIZE, OR COLOR.

FOR RESTAURANT SERVICES (U.S. CLS. 100 AND 101).

FIRST USE 1-4-2012; IN COMMERCE 1-4-2012.

CLASS 43—(Continued).

4,119,564. JIMMY LOPEZ, JR., AUSTIN, TX. SN 85-252,522. PUB. 7-19-2011, FILED 2-26-2011.

Playa Tacos

THE MARK CONSISTS OF STANDARD CHARACTERS WITHOUT CLAIM TO ANY PARTICULAR FONT, STYLE, SIZE, OR COLOR.

NO CLAIM IS MADE TO THE EXCLUSIVE RIGHT TO USE "TACOS", APART FROM THE MARK AS SHOWN.

THE ENGLISH TRANSLATION OF "PLAYA" IN THE MARK IS "BEACH".

FOR RESTAURANT SERVICES (U.S. CLS. 100 AND 101).

FIRST USE 6-24-2011; IN COMMERCE 6-24-2011.

4,119,610. CC INVESTMENTS LLC, GRAND JUNCTION, CO. SN 85-278,112. PUB. 8-9-2011, FILED 3-27-2011.

UNCLE NUB'S

THE MARK CONSISTS OF STANDARD CHARACTERS WITHOUT CLAIM TO ANY PARTICULAR FONT, STYLE, SIZE, OR COLOR.

FOR RESTAURANT AND BAR SERVICES, INCLUDING RESTAURANT CARRYOUT SERVICES; RESTAURANT SERVICES, INCLUDING SIT-DOWN SERVICE OF FOOD AND TAKE-OUT RESTAURANT SERVICES (U.S. CLS. 100 AND 101).

FIRST USE 12-19-2011; IN COMMERCE 12-19-2011.

4,119,631. SHANGHAI YIHAO CATERING COMPANY LIMITED, SHANGHAI CITY, CHINA. SN 85-293,569. PUB. 8-30-2011, FILED 4-13-2011.

NO CLAIM IS MADE TO THE EXCLUSIVE RIGHT TO USE THE NON-LATIN CHARACTERS WHICH TRANSLITERATE INTO SHANG HAI, APART FROM THE MARK AS SHOWN.

THE MARK CONSISTS OF TWO CHINESE CHARACTERS THAT TRANSLITERATED INTO SHANG HAI, THE LETTER "1", AND ONE CHINESE CHARACTER THAT TRANSLITERATED INTO HAO.

CLASS 43—(Continued).

THE NON-LATIN CHARACTERS IN THE MARK TRANSLITERATE TO SHANG; HAI; HAO AND THIS MEANS SHANGHAI; NUMBER IN ENGLISH.

FOR BAR SERVICES; BOARDING FOR ANIMALS; DAY-CARE CENTRES; HOTELS; MOTELS; PROVIDING CONFERENCE ROOMS; RENTAL OF CHAIRS, TABLES, TABLE LINEN, GLASSWARE; RESTAURANTS; RETIREMENT HOMES; TEA ROOMS (U.S. CLS. 100 AND 101).

FIRST USE 3-28-2008; IN COMMERCE 12-18-2011.

CLASS 44—MEDICAL, BEAUTY AND AGRICULTURAL SERVICES

4,118,801. SHUI T. LAI, PH.D., WINDERMERE, FL. SN 77-338,331. PUB. 10-21-2008, FILED 11-27-2007.

BETTER THAN PERFECT

THE MARK CONSISTS OF STANDARD CHARACTERS WITHOUT CLAIM TO ANY PARTICULAR FONT, STYLE, SIZE, OR COLOR.

FOR OPTOMETRY SERVICES, OPHTHALMOLOGY SERVICES, AND OPTICIAN SERVICES (U.S. CLS. 100 AND 101).

FIRST USE 11-9-2011; IN COMMERCE 11-9-2011.

4,118,855. SALCARE HOME HEALTH SERVICES, INC., NEW YORK, NY. SN 77-501,921. PUB. 11-11-2008, FILED 6-18-2008.

SALCARE HOME HEALTH SERVICES

THE MARK CONSISTS OF STANDARD CHARACTERS WITHOUT CLAIM TO ANY PARTICULAR FONT, STYLE, SIZE, OR COLOR.

NO CLAIM IS MADE TO THE EXCLUSIVE RIGHT TO USE "HOME HEALTH SERVICES", APART FROM THE MARK AS SHOWN.

FOR HOME HEALTH CARE SERVICES (U.S. CLS. 100 AND 101).

FIRST USE 11-1-2007; IN COMMERCE 11-1-2007.

CLASS 44—(Continued).

4,118,929. PERCEPTIVE INFORMATICS, INC., WALTHAM, MA. SN 77-773,205. PUB. 11-24-2009, FILED 7-2-2009.

PERCEPTIVE

THE MARK CONSISTS OF STANDARD CHARACTERS WITHOUT CLAIM TO ANY PARTICULAR FONT, STYLE, SIZE, OR COLOR.

OWNER OF U.S. REG. NOS. 3,142,466 AND 3,190,512. FOR MEDICAL TESTING, NAMELY, MEDICAL DIAGNOSTIC SERVICES; MEDICAL IMAGING AND RELATED ANALYSIS AND PROCESSING SERVICES (U.S. CLS. 100 AND 101).

FIRST USE 2-28-2002; IN COMMERCE 2-28-2002.

4,118,982. YOGA PURA, LLC, PHOENIX, AZ. SN 77-896,845. PUB. 7-13-2010, FILED 12-18-2009.

BOOTSTRAP

THE MARK CONSISTS OF STANDARD CHARACTERS WITHOUT CLAIM TO ANY PARTICULAR FONT, STYLE, SIZE, OR COLOR.

FOR PROVIDING INFORMATION FOR MILITARY SERVICE MEMBERS, NAMELY, PROVIDING LINKS TO THE WEBSITES OF OTHERS THAT FEATURE INFORMATION ABOUT HEALTH ISSUES IN THE NATURE OF CHRONIC STRESS-RELIEF SUPPORT AND STRESS REDUCTION THERAPY (U.S. CLS. 100 AND 101).

FIRST USE 1-6-2012; IN COMMERCE 1-6-2012.

4,119,029. GREER LABORATORIES, INC., LENOIR, NC. SN 77-932,309. PUB. 12-14-2010, FILED 2-10-2010.

GREER ALLERGY IMMUNOTHERAPY

THE MARK CONSISTS OF STANDARD CHARACTERS WITHOUT CLAIM TO ANY PARTICULAR FONT, STYLE, SIZE, OR COLOR.

OWNER OF U.S. REG. NOS. 917,452, 3,147,131, AND OTHERS.

NO CLAIM IS MADE TO THE EXCLUSIVE RIGHT TO USE "ALLERGY IMMUNOTHERAPY", APART FROM THE MARK AS SHOWN.

FOR VETERINARY SPECIALTY SERVICES, NAMELY, PROVIDING ADVANCED DIAGNOSTIC SERVICES FOR ANIMALS (U.S. CLS. 100 AND 101).

FIRST USE 4-30-2010; IN COMMERCE 4-30-2010.

CLASS 44—(Continued).

4,119,095. CRITICAL SIGNAL TECHNOLOGIES, INC., FARMINGTON HILLS, MI. SN 85-033,901. PUB. 11-16-2010, FILED 5-10-2010.

**CRITICAL SIGNAL
TECHNOLOGIES CARE PLAN
SOLUTIONS**

THE MARK CONSISTS OF STANDARD CHARACTERS WITHOUT CLAIM TO ANY PARTICULAR FONT, STYLE, SIZE, OR COLOR.

OWNER OF U.S. REG. NOS. 3,400,743 AND 3,514,695. NO CLAIM IS MADE TO THE EXCLUSIVE RIGHT TO USE "TECHNOLOGIES" AND "CARE PLAN SOLUTIONS", APART FROM THE MARK AS SHOWN.

FOR 24-HOUR RESPONSE CENTER WHICH PROVIDES MEDICAL INFORMATION TO EMERGENCY MEDICAL PERSONNEL AND ALLOWS MEMBERS TO UPDATE THEIR MEDICAL/PERSONAL FILES; CONSULTING SERVICES IN THE FIELDS OF HEALTH AND NUTRITION; COUNSELING SERVICES IN THE FIELDS OF HEALTH, NUTRITION AND LIFESTYLE WELLNESS; EMERGENCY MEDICAL ASSISTANCE; EMERGENCY MEDICAL RESPONSE SERVICES; GERIATRIC HEALTH CARE MANAGEMENT SERVICES; HEALTH CARE; HEALTH CARE SERVICES, NAMELY, WELLNESS PROGRAMS; HOME HEALTH CARE SERVICES; PROVIDING HEALTH CARE INFORMATION BY TELEPHONE; PROVIDING HEALTH INFORMATION; PROVIDING INFORMATION TO PATIENTS IN THE FIELD OF ADMINISTERING MEDICATIONS; PROVISION OF MEDICAL SERVICES BY HEALTH CARE PROFESSIONALS VIA THE INTERNET OR TELECOMMUNICATION NETWORKS; REMOTE MONITORING OF DATA INDICATIVE OF THE HEALTH OR CONDITION OF AN INDIVIDUAL OR GROUP OF INDIVIDUALS; WELLNESS AND HEALTH-RELATED CONSULTING SERVICES (U.S. CLS. 100 AND 101).

FIRST USE 6-26-2010; IN COMMERCE 6-26-2010.

4,119,213. VITAPATH GENETICS, INC., FOSTER CITY, CA. SN 85-096,746. PUB. 1-11-2011, FILED 7-30-2010.

VITAPATH

THE MARK CONSISTS OF STANDARD CHARACTERS WITHOUT CLAIM TO ANY PARTICULAR FONT, STYLE, SIZE, OR COLOR.

FOR DNA SCREENING FOR MEDICAL PURPOSES (U.S. CLS. 100 AND 101).

FIRST USE 9-1-2009; IN COMMERCE 9-1-2009.

CLASS 44—(Continued).

4,119,251. CHIROPRACTIC CARE OF MINNESOTA, INC., SHOREVIEW, MN. SN 85-122,687. PUB. 2-15-2011, FILED 9-3-2010.

HEALING IS BELIEVING

THE MARK CONSISTS OF STANDARD CHARACTERS WITHOUT CLAIM TO ANY PARTICULAR FONT, STYLE, SIZE, OR COLOR.

NO CLAIM IS MADE TO THE EXCLUSIVE RIGHT TO USE "HEALING", APART FROM THE MARK AS SHOWN, FOR CHIROPRACTIC CARE RELATED TO BACK PAIN (U.S. CLS. 100 AND 101).

FIRST USE 4-1-2011; IN COMMERCE 4-1-2011.

4,119,304. SURROGACY EXPERIENCE, LLC, NEPTUNE, NJ. SN 85-158,921. PUB. 4-5-2011, FILED 10-22-2010.



OWNER OF U.S. REG. NO. 3,905,854.
NO CLAIM IS MADE TO THE EXCLUSIVE RIGHT TO USE "SURROGACY", APART FROM THE MARK AS SHOWN.

THE MARK CONSISTS OF A HEART IN THE CENTER OF A CIRCLE WITH THE WORDING "THE SURROGACY" TO THE LEFT OF THE HEART IN THE CIRCLE WHERE THE WORD "THE" APPEARS CENTERED ABOVE THE LETTERS "ACY" IN THE WORD "SURROGACY" AND THE WORD "EXPERIENCE" TO THE RIGHT OF THE HEART IN THE CIRCLE. THE WORDING "SURROGACY" AND "EXPERIENCE" ARE OVERLINED AND UNDERLINED. THE WORDING "CONFIDENCE & CARE FROM DECISION TO DELIVERY" IS CENTERED BELOW THE WORDING "THE SURROGACY EXPERIENCE" AND THE HEART AND CIRCLE DESIGN.

FOR MATERNAL SURROGACY SERVICES; CONSULTATION SERVICES IN THE FIELD OF SURROGACY (U.S. CLS. 100 AND 101).

FIRST USE 11-12-2010; IN COMMERCE 11-12-2010.

CLASS 44—(Continued).

4,119,377. PPTP.NET, LLC, BEACH HAVEN, NJ. SN 85-196,213. PUB. 5-10-2011, FILED 12-13-2010.

**PATIENT PHYSICIAN TRUST
PARTNERSHIP**

THE MARK CONSISTS OF STANDARD CHARACTERS WITHOUT CLAIM TO ANY PARTICULAR FONT, STYLE, SIZE, OR COLOR.

NO CLAIM IS MADE TO THE EXCLUSIVE RIGHT TO USE "PATIENT PHYSICIAN" OR "PARTNERSHIP", APART FROM THE MARK AS SHOWN.

FOR MANAGEMENT, INFORMATION AND COMPLIANCE FOR PRESCRIPTION DRUGS IN THE NATURE OF PROVIDING INFORMATION ON MISUSE RISK EVALUATION AND MITIGATION STRATEGIES FOR PRESCRIPTION DRUGS AND FACILITATING THE EXCHANGE OF INFORMATION BETWEEN PATIENTS AND DRUG PRESCRIBERS (U.S. CLS. 100 AND 101).

FIRST USE 10-28-2009; IN COMMERCE 10-28-2009.

4,119,378. PPTP.NET, LLC, BEACH HAVEN, NJ. SN 85-196,216. PUB. 5-10-2011, FILED 12-13-2010.

**MEDICATION USAGE
UNDERSTANDING**

THE MARK CONSISTS OF STANDARD CHARACTERS WITHOUT CLAIM TO ANY PARTICULAR FONT, STYLE, SIZE, OR COLOR.

NO CLAIM IS MADE TO THE EXCLUSIVE RIGHT TO USE "MEDICATION USAGE", APART FROM THE MARK AS SHOWN.

FOR MANAGEMENT, INFORMATION AND COMPLIANCE FOR PRESCRIPTION DRUGS IN THE NATURE OF PROVIDING INFORMATION ON MISUSE RISK EVALUATION AND MITIGATION STRATEGIES FOR PRESCRIPTION DRUGS AND FACILITATING THE EXCHANGE OF INFORMATION BETWEEN PATIENTS AND DRUG PRESCRIBERS (U.S. CLS. 100 AND 101).

FIRST USE 10-28-2009; IN COMMERCE 10-28-2009.

CLASS 44—(Continued).

4,119,379. PPTP.NET, LLC, BEACH HAVEN, NJ. SN 85-196,234. PUB. 5-10-2011, FILED 12-13-2010.

MUU

THE MARK CONSISTS OF STANDARD CHARACTERS WITHOUT CLAIM TO ANY PARTICULAR FONT, STYLE, SIZE, OR COLOR.

FOR MANAGEMENT, INFORMATION AND COMPLIANCE FOR PRESCRIPTION DRUGS IN THE NATURE OF PROVIDING INFORMATION ON MISUSE RISK EVALUATION AND MITIGATION STRATEGIES FOR PRESCRIPTION DRUGS AND FACILITATING THE EXCHANGE OF INFORMATION BETWEEN PATIENTS AND DRUG PRESCRIBERS (U.S. CLS. 100 AND 101).

FIRST USE 10-28-2009; IN COMMERCE 10-28-2009.

4,119,428. COGNITIVE SCIENCE LLC, ITHACA, NY. SN 85-205,071. PUB. 5-24-2011, FILED 12-23-2010.

MMETHOD

THE MARK CONSISTS OF STANDARD CHARACTERS WITHOUT CLAIM TO ANY PARTICULAR FONT, STYLE, SIZE, OR COLOR.

FOR PROVIDING INFORMATION, ADVICE, CONSULTATION, AND SUPPORT FOR WEIGHT REDUCTION, DIET PLANNING, AND NUTRITION COUNSELING THROUGH BEHAVIOR AND HABIT MODIFICATION IN THE FIELDS OF EATING BEHAVIOR, WEIGHT REDUCTION, WEIGHT CONTROL, NUTRITION, AND HEALTHY LIFESTYLE (U.S. CLS. 100 AND 101).

FIRST USE 1-24-2011; IN COMMERCE 1-24-2011.

4,119,429. THE HEALTHIER WAY INSTITUTE, LLC, DELRAY BEACH, FL. SN 85-205,318. PUB. 5-24-2011, FILED 12-23-2010.

Medical Stewardship

THE MARK CONSISTS OF STANDARD CHARACTERS WITHOUT CLAIM TO ANY PARTICULAR FONT, STYLE, SIZE, OR COLOR.

NO CLAIM IS MADE TO THE EXCLUSIVE RIGHT TO USE "MEDICAL", APART FROM THE MARK AS SHOWN.

FOR ALTERNATIVE MEDICINE SERVICES (U.S. CLS. 100 AND 101).

FIRST USE 1-1-2010; IN COMMERCE 1-1-2011.

CLASS 44—(Continued).

4,119,499. BLEVINS, LARRY W, DBA MESOS, LLC, WINTER PARK, FL. SN 85-225,035. PUB. 5-31-2011, FILED 1-24-2011.

V-Lift

THE MARK CONSISTS OF STANDARD CHARACTERS WITHOUT CLAIM TO ANY PARTICULAR FONT, STYLE, SIZE, OR COLOR.

FOR COSMETIC AND PLASTIC SURGERY, NAMELY, A MINIMALLY INVASIVE FACE/NECK LIFT DONE UNDER LOCAL ANESTHESIA (U.S. CLS. 100 AND 101).

FIRST USE 9-30-2011; IN COMMERCE 9-30-2011.

4,119,595. BLACKMORE, JORDAN, NEW YORK, NY. SN 85-267,954. PUB. 7-26-2011, FILED 3-15-2011.

THREE SQUARES STUDIO

THE MARK CONSISTS OF STANDARD CHARACTERS WITHOUT CLAIM TO ANY PARTICULAR FONT, STYLE, SIZE, OR COLOR.

NO CLAIM IS MADE TO THE EXCLUSIVE RIGHT TO USE "STUDIO", APART FROM THE MARK AS SHOWN.

FOR HAIR SALON SERVICES (U.S. CLS. 100 AND 101).

FIRST USE 3-15-2011; IN COMMERCE 3-15-2011.

CLASS 45—PERSONAL AND LEGAL SERVICES

4,118,924. REVERE SECURITY CORPORATION, ADDISON, TX. SN 77-764,446. PUB. 5-25-2010, FILED 6-19-2009.

HUMMINGBIRD

THE MARK CONSISTS OF STANDARD CHARACTERS WITHOUT CLAIM TO ANY PARTICULAR FONT, STYLE, SIZE, OR COLOR.

FOR LICENSING OF CRYPTOGRAPHIC ALGORITHMS TO MANUFACTURERS OF WIRELESS SENSORS, RFID TAGS AND OTHER SEMICONDUCTOR DEVICES (U.S. CLS. 100 AND 101).

FIRST USE 10-5-2011; IN COMMERCE 10-5-2011.

CLASS 45—(Continued).

4,119,215. HEYROOMEE LLC, WHITE PLAINS, NY. SN 85-096,853. PUB. 5-24-2011, FILED 7-30-2010.



THE COLOR(S) ORANGE-RED AND WHITE IS/ARE CLAIMED AS A FEATURE OF THE MARK.

THE MARK CONSISTS OF A BRIGHT ORANGE-RED CIRCLE CONTAINING A LARGE, WHITE CAPITAL "H" IN ITS CENTER, WITH A WHITE DOT-DASH SYMBOL BOTH ABOVE AND BELOW THE CENTER CROSSBAR OF THE "H".

FOR ONLINE SOCIAL NETWORKING SERVICES (U.S. CLS. 100 AND 101).

FIRST USE 4-1-2011; IN COMMERCE 4-1-2011.

4,119,272. FIRST DATA RESOURCES, LLC, GREENWOOD VILLAGE, CO. SN 85-139,510. PUB. 5-24-2011, FILED 9-28-2010.

DEFENSEEDGE

THE MARK CONSISTS OF STANDARD CHARACTERS WITHOUT CLAIM TO ANY PARTICULAR FONT, STYLE, SIZE, OR COLOR.

FOR PROVIDING FRAUD DETECTION SERVICES IN THE FIELD OF BANKING FOR PAYMENT TRANSACTIONS, FINANCIAL ACCOUNTS, AND ACCOUNTHOLDER INFORMATION VIA A GLOBAL COMPUTER NETWORK (U.S. CLS. 100 AND 101).

FIRST USE 8-26-2011; IN COMMERCE 8-26-2011.

CLASS 45—(Continued).

4,119,342. SANES, HEIDI, DELRAY BEACH, FL. SN 85-184,176. PUB. 4-26-2011, FILED 11-23-2010.

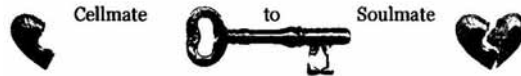

THE MARK CONSISTS OF A 1/2 OF A BROKEN HEART, A SKELETON KEY, AND THEN 2 HALVES OF A BROKEN HEART TOGETHER. THE WORDING "CELLMATE TO SOULMATE" IS ABOVE THE DESIGN.

FOR DATING SERVICES (U.S. CLS. 100 AND 101).
FIRST USE 6-0-2010; IN COMMERCE 6-0-2010.

4,119,349. THE LOVER SQUIRREL, LLC, CLARKSBURG, WV. SN 85-185,680. PUB. 5-3-2011, FILED 11-27-2010.

PostaDump

THE MARK CONSISTS OF STANDARD CHARACTERS WITHOUT CLAIM TO ANY PARTICULAR FONT, STYLE, SIZE, OR COLOR.

FOR ONLINE SOCIAL NETWORKING SERVICE AND WEBSITE THAT FACILITATES THE TERMINATION OF A RELATIONSHIP BY PUBLISHING THE BREAKUP VIA ONLINE MEDIA (U.S. CLS. 100 AND 101).

FIRST USE 11-20-2011; IN COMMERCE 11-20-2011.

4,119,454. COHEN FOX P.A., MIAMI, FL. SN 85-212,685. PUB. 5-24-2011, FILED 1-7-2011.

EXTRAORDINARY RELIEF

THE MARK CONSISTS OF STANDARD CHARACTERS WITHOUT CLAIM TO ANY PARTICULAR FONT, STYLE, SIZE, OR COLOR.

FOR LEGAL SERVICES (U.S. CLS. 100 AND 101).

FIRST USE 4-28-2011; IN COMMERCE 4-28-2011.

CLASS 45—(Continued).

4,119,561. BLISTT, LLC, STATE COLLEGE, PA. SN 85-250,632.
PUB. 11-8-2011, FILED 2-24-2011.

CLASS 45—(Continued).

4,119,707. DAVID FREEMAN, LAGUNA BEACH, CA. SN 85-
349,884. PUB. 11-8-2011, FILED 6-18-2011.

blistt

THE MARK CONSISTS OF STANDARD CHARACTERS
WITHOUT CLAIM TO ANY PARTICULAR FONT, STYLE,
SIZE, OR COLOR.

FOR INTERNET-BASED SOCIAL NETWORKING SER-
VICES; ONLINE SOCIAL NETWORKING SERVICES IN
THE FIELD OF TRAVEL, PERSONAL GOAL ACHIEVE-
MENT, EXTREME ACTIVITIES AND SPORTS (U.S. CLS.
100 AND 101).

FIRST USE 10-1-2011; IN COMMERCE 10-1-2011.

CULTURESHIFT

THE MARK CONSISTS OF STANDARD CHARACTERS
WITHOUT CLAIM TO ANY PARTICULAR FONT, STYLE,
SIZE, OR COLOR.

FOR CONSULTING SERVICES CONCERNING LEGAL
MATTERS (U.S. CLS. 100 AND 101).

FIRST USE 10-15-2011; IN COMMERCE 10-15-2011.

* * * * *

PRIOR UNITED STATES CLASSIFICATION

APPLICATION IN ONE CLASS

CERTIFICATION MARKS

CLASS B—SERVICES

4,118,992. ONCOLOGY REHAB PARTNERS, LLC, NORTH-BORO, MA. SN 77-909,149. PUB. 5-17-2011, FILED 1-11-2010.

NO CLAIM IS MADE TO THE EXCLUSIVE RIGHT TO USE "CLINICIAN", APART FROM THE MARK AS SHOWN.

THE CERTIFICATION MARK, AS INTENDED TO BE USED BY AUTHORIZED PERSONS, IS INTENDED TO CERTIFY THAT THE INDIVIDUALS DISPLAYING THE MARK HAVE COMPLETED THE EDUCATIONAL REQUIREMENTS OF THE CERTIFIER AND CONTINUE TO MEET THE CONTINUING EDUCATIONAL REQUIREMENTS OF THE CERTIFIER.

FOR ONCOLOGY REHABILITATION SERVICES (U.S. CL. B).

FIRST USE 7-0-2011; IN COMMERCE 7-0-2011.

STAR Clinician

THE MARK CONSISTS OF STANDARD CHARACTERS WITHOUT CLAIM TO ANY PARTICULAR FONT, STYLE, SIZE, OR COLOR.

* * * * *

SUPPLEMENTAL REGISTER

These registrations are not subject to opposition.

SECTION 1.— INTERNATIONAL CLASSIFICATION

The short titles associated below with the international class numbers are terms designed merely for quick identification and are not an official part of the international classification. The full names of international classes are given in section 6.1 of the trademark rules of practice.

The designation "U.S. Cl." appearing in this section refers to the U.S. class in effect prior to Sep. 1, 1973 rather than the international class which applies to applications filed on or after that date. For adoption of international classification see notice in the OFFICIAL GAZETTE of Jun. 26, 1973 (911 O.G. TM 210).

Application in more than one class

4,119,741. HELP AT HOME, INC., CHICAGO, IL. SN 77-944,104. FILED P.R. 2-24-2010; AM. S.R. 10-6-2011. 4,119,743. SYNERGYLIST, INC., PALO ALTO, CA. SN 85-038,661. FILED P.R. 5-14-2010; AM. S.R. 11-10-2011.

HELP AT HOME INC.

STARTUPDIGEST

THE MARK CONSISTS OF STANDARD CHARACTERS WITHOUT CLAIM TO ANY PARTICULAR FONT, STYLE, SIZE, OR COLOR.

NO CLAIM IS MADE TO THE EXCLUSIVE RIGHT TO USE "INC.", APART FROM THE MARK AS SHOWN.

CLASS 37—CONSTRUCTION AND REPAIR

FOR CLEANING OF RESIDENTIAL HOMES FOR PERSONS REQUIRING HOUSEHOLD ASSISTANCE; LAUNDRY SERVICES, IRONING (U.S. CLS. 100, 103 AND 106).

FIRST USE 0-0-1982; IN COMMERCE 0-0-1982.

CLASS 39—TRANSPORTATION AND STORAGE

FOR TRANSPORTATION OF PASSENGERS, NAMELY, ADULTS, ELDERLY, DISABLED, AND CHILDREN (U.S. CLS. 100 AND 105).

FIRST USE 0-0-1982; IN COMMERCE 0-0-1982.

CLASS 44—MEDICAL, BEAUTY AND AGRICULTURAL SERVICES

FOR HOME NURSING; HOME HEALTH AID NURSING AND HOME CERTIFIED NURSING SERVICES; HOSPICE SERVICE; PHYSICAL THERAPY; SPEECH THERAPY (U.S. CLS. 100 AND 101).

FIRST USE 0-0-1982; IN COMMERCE 0-0-1982.

THE MARK CONSISTS OF STANDARD CHARACTERS WITHOUT CLAIM TO ANY PARTICULAR FONT, STYLE, SIZE, OR COLOR.

CLASS 35—ADVERTISING AND BUSINESS

FOR PROVIDING A WEB SITE FEATURING INFORMATION RELATING TO BUSINESS ISSUES IN THE FIELD OF TECHNOLOGY AND BUSINESS ENTREPRENEURSHIP EVENTS (U.S. CLS. 100, 101 AND 102).

FIRST USE 6-21-2010; IN COMMERCE 6-21-2010.

CLASS 41—EDUCATION AND ENTERTAINMENT

FOR PROVIDING ON-LINE, NON-DOWNLOADABLE ELECTRONIC NEWSLETTERS DELIVERED BY E-MAIL FEATURING INFORMATION, ARTICLES AND EVENT CALENDARS IN THE FIELD OF TECHNOLOGY AND ENTREPRENEURSHIP EVENTS; PROVIDING A WEBSITE FEATURING NON-DOWNLOADABLE PUBLICATIONS IN THE NATURE OF ARTICLES IN THE FIELD OF TECHNOLOGY AND ENTREPRENEURSHIP EVENTS (U.S. CLS. 100, 101 AND 107).

FIRST USE 6-21-2010; IN COMMERCE 6-21-2010.

4,119,746. MBEACH1, LLLP, MIAMI BEACH, FL. SN 85-106,127. FILED P.R. 8-12-2010; AM. S.R. 12-21-2011.

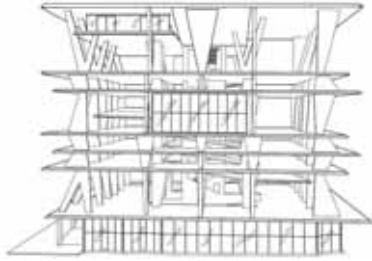

THE MARK CONSISTS OF THREE-DIMENSIONAL TRADE DRESS FOR THE APPEARANCE OF A SEVEN-STORY BUILDING HAVING AN OPEN CONCRETE STRUCTURE WITH VARYING CEILING HEIGHTS. THE ENTIRE FIRST LEVEL IS ENCLOSED WITH LARGE GLASS WINDOWS, AND THE FIFTH LEVEL ALSO INCLUDES A SMALL, CENTRALLY LOCATED, GLASS-ENCLOSED CUT-OUT. THE UPPER LEFT HAND CORNER OF THE SEVENTH FLOOR FURTHER INCLUDES A SUB-LEVEL, THE LOWER AND UPPER BOUNDARIES OF WHICH ARE DELINEATED BY A SMALL RAISED PLATFORM AND THE CEILING OF THE SEVENTH FLOOR, RESPECTIVELY. BEGINNING ON THE SECOND STORY, THE FLOORS ARE SEPARATED BY ANGULAR CUTOUT BEAMS OF VARYING HEIGHTS AND SHAPES. THE LARGER SECOND, FIFTH AND SEVENTH LEVELS ARE SUPPORTED BY LONG, ANGULAR, V-SHAPED BEAMS THAT EXTEND FROM THE FLOOR TO THE CEILING OF EACH INDIVIDUAL LEVEL. THE MORE COMPRESSED THIRD, FOURTH AND SIXTH LEVELS ARE SUPPORTED BY SIMILAR, BUT SHORTER, TRAPEZOIDAL BEAMS EXTENDING FROM THE FLOOR TO THE CEILING OF EACH LEVEL. THE BEAMS ARE ARRANGED IN A VARIETY OF POSITIONS AND CONFIGURATIONS.

CLASS 35—ADVERTISING AND BUSINESS

FOR BUSINESS SERVICES, NAMELY, FACILITIES MANAGEMENT OF TECHNICAL OPERATIONS (U.S. CLS. 100, 101 AND 102).
FIRST USE 11-20-2009; IN COMMERCE 11-20-2009.

CLASS 36—INSURANCE AND FINANCIAL

FOR REAL ESTATE SERVICES, NAMELY, LEASING, RENTING, AND MANAGEMENT OF COMMERCIAL PROPERTY (U.S. CLS. 100, 101 AND 102).
FIRST USE 11-20-2009; IN COMMERCE 11-20-2009.
4,119,769. 24-365 PET CARE SOLUTIONS, LLC, FARMINGTON, MI. SN 85-235,722. FILED P.R. 2-7-2011; AM. S.R. 11-7-2011.

24-365 PET CARE SOLUTIONS

THE MARK CONSISTS OF STANDARD CHARACTERS WITHOUT CLAIM TO ANY PARTICULAR FONT, STYLE, SIZE, OR COLOR.

CLASS 44—MEDICAL, BEAUTY AND AGRICULTURAL SERVICES

FOR PET CARE SERVICES, NAMELY, DOG WALKING AND PET GROOMING (U.S. CLS. 100 AND 101).
FIRST USE 9-16-2011; IN COMMERCE 9-16-2011.

CLASS 45—PERSONAL AND LEGAL SERVICES

FOR PET CARE SERVICES, NAMELY, PET SITTING (U.S. CLS. 100 AND 101).
FIRST USE 9-16-2011; IN COMMERCE 9-16-2011.

4,119,770. STEPHEN REICH, PH.D., PSYCHOLOGIST, P.C., NEW YORK, NY. SN 85-240,471. FILED P.R. 2-11-2011; AM. S.R. 2-10-2012.

FORENSIC PSYCHOLOGY GROUP

THE MARK CONSISTS OF STANDARD CHARACTERS WITHOUT CLAIM TO ANY PARTICULAR FONT, STYLE, SIZE, OR COLOR.

NO CLAIM IS MADE TO THE EXCLUSIVE RIGHT TO USE "GROUP", APART FROM THE MARK AS SHOWN.

CLASS 44—MEDICAL, BEAUTY AND AGRICULTURAL SERVICES

FOR PROVIDING PSYCHOLOGICAL AND PSYCHIATRIC ASSESSMENT SERVICES IN LEGAL MATTERS IN THE FIELDS OF CRIMINAL LAW, PERSONAL INJURY LAW, EMPLOYMENT LAW AND IMMIGRATION LAW, AND PREPARATION OF PSYCHOLOGICAL AND PSYCHIATRIC ASSESSMENT REPORTS IN CONNECTION THEREWITH (U.S. CLS. 100 AND 101).
FIRST USE 4-1-2001; IN COMMERCE 4-1-2001.

CLASS 45—PERSONAL AND LEGAL SERVICES

FOR PROVIDING LITIGATION CONSULTING SERVICES IN THE FIELDS OF CRIMINAL LAW, PERSONAL INJURY LAW, EMPLOYMENT LAW AND IMMIGRATION LAW; PROVIDING EXPERT WITNESS SERVICES IN LEGAL MATTERS IN THE FIELDS OF CRIMINAL LAW, PERSONAL INJURY LAW, EMPLOYMENT LAW AND IMMIGRATION LAW (U.S. CLS. 100 AND 101).
FIRST USE 4-1-2001; IN COMMERCE 4-1-2001.

4,119,787. INTELLISTRY INFORMATION SYSTEMS, INC., DBA GEO.TO, IRVINE, CA. SN 85-296,962. FILED P.R. 4-15-2011; AM. S.R. 1-25-2012.

GEOLINK

THE MARK CONSISTS OF STANDARD CHARACTERS WITHOUT CLAIM TO ANY PARTICULAR FONT, STYLE, SIZE, OR COLOR.

CLASS 35—ADVERTISING AND BUSINESS

FOR PROVIDING AND MAINTAINING AN ONLINE SEARCHABLE DATABASE CONTAINING BUSINESS INFORMATION IN THE NATURE OF PHYSICAL AND ELECTRONIC LOCATION IDENTIFIERS FOR BUSINESSES THAT PROVIDE COMMERCIAL INFORMATION REGARDING BUSINESSES; COORDINATING LINKS, LOCATION NAMES AND ADDRESSES FOR A GLOBAL COMPUTER INFORMATION NETWORK FOR BUSINESS PURPOSES (U.S. CLS. 100, 101 AND 102).

FIRST USE 6-30-2011; IN COMMERCE 6-30-2011.

CLASS 42—SCIENTIFIC AND COMPUTER SERVICES

FOR CARTOGRAPHY AND MAPPING; PROVIDING CUSTOMER-DEFINED AND GENERATED CONTENT AND CONTENT OF OTHERS BASED ON THE KNOWN OR ESTIMATED GEOGRAPHICAL LOCATION OF BUSINESSES, EVENTS, RESIDENCES, PERSONAL ADDRESSES, AND PHYSICAL LOCATIONS THROUGH A GLOBAL COMPUTER NETWORK; SEARCHING AND RETRIEVING INFORMATION, SITES, AND OTHER RESOURCES BASED ON PHYSICAL AND ELECTRONIC LOCATION IDENTIFIERS AVAILABLE ON COMPUTER NETWORKS FOR OTHERS; COMPUTER SERVICES, NAMELY, CREATING COMPUTER NETWORK-BASED INDEXES OF INFORMATION, WEBSITES AND RESOURCES (U.S. CLS. 100 AND 101).

FIRST USE 6-30-2011; IN COMMERCE 6-30-2011.

4,119,798. TRADE SERVICE COMPANY, LLC, SAN DIEGO, CA. SN 85-303,966. FILED P.R. 4-25-2011; AM. S.R. 2-6-2012.

SUBMITTAL MANAGER

THE MARK CONSISTS OF STANDARD CHARACTERS WITHOUT CLAIM TO ANY PARTICULAR FONT, STYLE, SIZE, OR COLOR.

NO CLAIM IS MADE TO THE EXCLUSIVE RIGHT TO USE "MANAGER", APART FROM THE MARK AS SHOWN.

CLASS 9—ELECTRICAL AND SCIENTIFIC APPARATUS

FOR DOWNLOADABLE SOFTWARE FROM THE INTERNET FEATURING A DATABASE PROGRAM FOR USE BY ELECTRICAL AND PLUMBING CONTRACTORS AND DISTRIBUTORS IN COMPILING AND DOCUMENTING PARTS AND RELATED SPECIFICATIONS INCLUDING MANUFACTURER CATALOGS WITH IMAGES, TO BE USED IN SUBMITTALS TO ARCHITECTS AND OWNERS IN FULFILLING CONSTRUCTION CONTRACTS (U.S. CLS. 21, 23, 26, 36 AND 38).

FIRST USE 3-1-2011; IN COMMERCE 3-1-2011.

CLASS 42—SCIENTIFIC AND COMPUTER SERVICES

FOR PROVIDING NON-DOWNLOADABLE SOFTWARE VIA THE INTERNET FEATURING A DATABASE PROGRAM FOR USE BY ELECTRICAL AND PLUMBING CONTRACTORS AND DISTRIBUTORS IN COMPILING AND DOCUMENTING PARTS AND RELATED SPECIFICATIONS INCLUDING MANUFACTURER CATALOGS WITH IMAGES, TO BE USED IN SUBMITTALS TO ARCHITECTS AND OWNERS IN FULFILLING CONSTRUCTION CONTRACTS (U.S. CLS. 100 AND 101).

FIRST USE 3-1-2011; IN COMMERCE 3-1-2011.

4,119,831. CAADES SINALOA, A.C., COYOACAN, SINALOA 80000, MEXICO. SN 85-375,236. FILED P.R. 7-19-2011; AM. S.R. 1-10-2012.

CERTIFIED: FRESH & RELIABLE

THE MARK CONSISTS OF STANDARD CHARACTERS WITHOUT CLAIM TO ANY PARTICULAR FONT, STYLE, SIZE, OR COLOR.

NO CLAIM IS MADE TO THE EXCLUSIVE RIGHT TO USE "FRESH", APART FROM THE MARK AS SHOWN.

CLASS 31—NATURAL AGRICULTURAL PRODUCTS

FOR FRESH FRUIT AND FRESH VEGETABLES (U.S. CLS. 1 AND 46).

FIRST USE 10-0-2010; IN COMMERCE 10-0-2010.

CLASS 35—ADVERTISING AND BUSINESS

FOR IMPORT AND WHOLESALE DISTRIBUTORSHIP SERVICES FEATURING FRESH FRUITS AND VEGETABLES (U.S. CLS. 100, 101 AND 102).

FIRST USE 10-0-2010; IN COMMERCE 10-0-2010.

4,119,847. 4K COMPUTER LLC, HOUSTON, TX. SN 85-408,830. FILED 8-26-2011.

4K

THE MARK CONSISTS OF STANDARD CHARACTERS WITHOUT CLAIM TO ANY PARTICULAR FONT, STYLE, SIZE, OR COLOR.

CLASS 9—ELECTRICAL AND SCIENTIFIC APPARATUS

FOR COMMUNICATIONS SERVERS; COMPUTER NETWORK SERVER; COMPUTER SERVERS; DIGITAL MEDIA SERVERS; INTERNET SERVERS; INTRANET SERVERS; IP VIDEO SERVERS; NETWORK SERVERS (U.S. CLS. 21, 23, 26, 36 AND 38).

FIRST USE 6-26-2009; IN COMMERCE 6-26-2009.

CLASS 38—COMMUNICATION

FOR AUDIO AND VIDEO BROADCASTING SERVICES OVER THE INTERNET; BROADCASTING OF TELEVISION PROGRAMMES; BROADCASTING OF VIDEO AND AUDIO PROGRAMMING OVER THE INTERNET; BROADCASTING PROGRAMS VIA A GLOBAL COMPUTER NETWORK; BROADCASTING SERVICES AND PROVISION OF TELECOMMUNICATION ACCESS TO FILMS AND TELEVISION PROGRAMMES PROVIDED VIA A VIDEO-ON-DEMAND SERVICE; BROADCASTING SERVICES AND PROVISION OF TELECOMMUNICATION ACCESS TO VIDEO AND AUDIO CONTENT PROVIDED VIA A VIDEO-ON-DEMAND SERVICE VIA THE INTERNET; HOSTED PBX SERVICES; INTERNET BROADCASTING SERVICES; INTERNET PROTOCOL TELEVISION (IPTV) TRANSMISSION SERVICES; INTERNET RADIO BROADCASTING SERVICES; PROVIDING CO-LOCATION SERVICES FOR VOICE, VIDEO AND DATA COMMUNICATIONS APPLICATIONS; RADIO AND TELEVISION BROADCASTING SERVICES; RADIO AND TELEVISION PROGRAMME BROADCASTING; RADIO BROADCASTING; TELEVISION AND RADIO BROADCASTING SERVICES; TELEVISION BROADCASTING; TELEVISION BROADCASTING CONSULTATION; TELEVISION BROADCASTING INFORMATION; TELEVISION PROGRAMME BROADCASTING; VIDEO BROADCASTING; VIDEO BROADCASTING AND TRANSMISSION SERVICES VIA THE INTERNET, FEATURING FILMS AND MOVIES; VIDEO BROADCASTING SERVICES OVER THE INTERNET OR OTHER COMMUNICATIONS NETWORK FEATURING THE UPLOADED, POSTED AND TAGGED VIDEOS OF OTHERS; VIDEO BROADCASTING SERVICES OVER THE INTERNET OR OTHER COMMUNICATIONS NETWORK, NAMELY, ELECTRONICALLY TRANSMITTING VIDEO CLIPS; VIDEO BROADCASTING SERVICES VIA THE INTERNET; ALL IN SD AND HD FORMATS (U.S. CLS. 100, 101 AND 104).

FIRST USE 3-1-2011; IN COMMERCE 3-1-2011.

CLASS 42—SCIENTIFIC AND COMPUTER SERVICES

FOR COMPUTER CO-LOCATION SERVICES, NAMELY, PROVIDING FACILITIES FOR THE LOCATION OF COMPUTER SERVERS WITH THE EQUIPMENT OF OTHERS; COMPUTER CONSULTATION; COMPUTER HARDWARE AND SOFTWARE CONSULTING SERVICES; COMPUTER NETWORK CONFIGURATION SERVICES; COMPUTER SERVICES, NAMELY, CLOUD HOSTING PROVIDER SERVICES; COMPUTER SERVICES, NAMELY, HOSTING ON-LINE WEB FACILITIES FOR OTHERS FOR ORGANIZING AND CONDUCTING ONLINE MEETINGS, GATHERINGS, AND INTERACTIVE DISCUSSIONS; COMPUTER SERVICES, NAMELY, INTEGRATION OF COMPUTER SOFTWARE INTO MULTIPLE SYSTEMS AND NETWORKS; COMPUTER SERVICES, NAMELY, PROVIDING VIRTUAL AND NON VIRTUAL APPLICATION SERVERS, WEB SERVERS, FILE SERVERS, CO-LOCATION SERVERS, LOAD BALANCING SERVERS, REDUNDANCY SERVERS, MEDIA SERVERS AND DATABASE SERVERS OF VARIABLE CAPACITY TO THIRD PARTY COMPUTING AND DATA STORAGE FACILITIES; COMPUTER TECHNOLOGY SUPPORT SERVICES, NAMELY, HELP DESK SERVICES; COMPUTER WEBSITE DESIGN; HOSTING INTERNET SITES FOR OTHERS; HOSTING OF DIGITAL CONTENT ON THE INTERNET; HOSTING OF WEB SITES; HOSTING THE WEB SITES OF OTHERS ON A COMPUTER SERVER FOR A GLOBAL COMPUTER NETWORK; HOSTING WEBSITES ON THE INTERNET; RENTAL OF SPACE IN A COMPUTER CO-LOCATION FACILITY FOR CONTAINERIZED DATA CENTERS OF OTHERS; RENTAL OF WEB SERVERS; WEB SITE HOSTING SERVICES (U.S. CLS. 100 AND 101).

FIRST USE 4-11-2005; IN COMMERCE 4-11-2005.

4,119,848. BENJAMIN MEDIA, INC., PENINSULA, OH. SN 85-409,334. FILED P.R. 8-29-2011; AM. S.R. 1-30-2012.

NORTH AMERICAN OIL & GAS PIPELINES

THE MARK CONSISTS OF STANDARD CHARACTERS WITHOUT CLAIM TO ANY PARTICULAR FONT, STYLE, SIZE, OR COLOR.

CLASS 16—PAPER GOODS AND PRINTED MATTER

FOR PRINTED MAGAZINES RELATING TO PIPELINE CONSTRUCTION (U.S. CLS. 2, 5, 22, 23, 29, 37, 38 AND 50).

FIRST USE 12-0-2011; IN COMMERCE 12-0-2011.

CLASS 41—EDUCATION AND ENTERTAINMENT

FOR ONLINE MAGAZINES RELATING TO PIPELINE CONSTRUCTION (U.S. CLS. 100, 101 AND 107).

FIRST USE 12-0-2011; IN COMMERCE 12-0-2011.

MARCH 27, 2012

U.S. PATENT AND TRADEMARK OFFICE

TM 1341

4,119,870. PALM HARBOR HOMES, INC., DBA NATION-
WIDE HOMES, PHOENIX, AZ. SN 85-443,609. FILED
P.R. 10-10-2011; AM. S.R. 2-2-2012.

**CLASS 19—NON-METALLIC BUILDING MA-
TERIALS**

FOR MODULAR HOMES; PRE-FABRICATED HOMES
(U.S. CLS. 1, 12, 33 AND 50).
FIRST USE 1-19-2010; IN COMMERCE 1-19-2010.

ECO COTTAGES

THE MARK CONSISTS OF STANDARD CHARACTERS
WITHOUT CLAIM TO ANY PARTICULAR FONT, STYLE,
SIZE, OR COLOR.

NO CLAIM IS MADE TO THE EXCLUSIVE RIGHT TO
USE "COTTAGES", APART FROM THE MARK AS SHOWN.

CLASS 37—CONSTRUCTION AND REPAIR

FOR RESIDENTIAL AND COMMERCIAL BUILDING
CONSTRUCTION (U.S. CLS. 100, 103 AND 106).
FIRST USE 1-19-2010; IN COMMERCE 1-19-2010.

* * * * *

SECTION 2.— INTERNATIONAL CLASSIFICATION

The short titles associated below with the international class numbers are terms designed merely for quick identification and are not an official part of the international classification. The full names of international classes are given in section 6.1 of the trademark rules of practice.

The designation "U.S. Cl." appearing in this section refers to the U.S. class in effect prior to Sep. 1, 1973 rather than the international class which applies to applications filed on or after that date. For adoption of international classification see notice in the OFFICIAL GAZETTE of Jun. 26, 1973 (911 O.G. TM 210).

Application in one class

CLASS 1—CHEMICALS

4,119,751. 3M COMPANY, ST. PAUL, MN. SN 85-131,229. FILED P.R. 9-16-2010; AM. S.R. 1-25-2012.

RED MEANS LEAD

THE MARK CONSISTS OF STANDARD CHARACTERS WITHOUT CLAIM TO ANY PARTICULAR FONT, STYLE, SIZE, OR COLOR.

FOR LEAD DETECTION KITS COMPRISING CHEMICALLY TREATED SWABS OR CHEMICAL SOLUTIONS FOR HOUSEHOLD AND INDUSTRIAL USE (U.S. CLS. 1, 5, 6, 10, 26 AND 46).

FIRST USE 12-31-2010; IN COMMERCE 12-31-2010.

4,119,795. CELL SIGNALING TECHNOLOGY, INC., DANVERS, MA. SN 85-302,483. FILED P.R. 4-22-2011; AM. S.R. 2-1-2012.

PTMScan

THE MARK CONSISTS OF STANDARD CHARACTERS WITHOUT CLAIM TO ANY PARTICULAR FONT, STYLE, SIZE, OR COLOR.

OWNER OF U.S. REG. NO. 3,891,598.

FOR BIOCHEMICAL REAGENTS USED FOR NON-MEDICAL PURPOSES; BIOCHEMICALS, NAMELY, MONOCLONAL ANTIBODIES FOR IN VITRO SCIENTIFIC OR RESEARCH USE; BIOCHEMICALS, NAMELY, POLYPEPTIDES FOR IN VITRO RESEARCH USE; CHEMICAL REAGENTS FOR NON-MEDICAL PURPOSES; REAGENT FOR CHEMICAL ANALYSES; REAGENTS FOR RESEARCH PURPOSES; REAGENTS FOR SCIENTIFIC OR MEDICAL RESEARCH USE; REAGENTS FOR USE IN SCIENTIFIC APPARATUS FOR CHEMICAL OR BIOLOGICAL ANALYSIS (U.S. CLS. 1, 5, 6, 10, 26 AND 46).

FIRST USE 1-20-2010; IN COMMERCE 1-20-2010.

CLASS 1—(Continued).

4,119,813. INTERNATIONAL ASSAYING SERVICES AND SUPPLIES, INC., COSTA MESA, CA. SN 85-330,325. FILED P.R. 5-25-2011; AM. S.R. 1-31-2012.

METALLON

THE MARK CONSISTS OF STANDARD CHARACTERS WITHOUT CLAIM TO ANY PARTICULAR FONT, STYLE, SIZE, OR COLOR.

THE ENGLISH TRANSLATION OF "METALLON" IN THE MARK IS "METAL".

FOR NON-STICK CHEMICAL SPRAY PREPARATION FOR USE IN CASTING OF PRECIOUS METALS, NAMELY, GOLD (U.S. CLS. 1, 5, 6, 10, 26 AND 46).

FIRST USE 6-1-2011; IN COMMERCE 6-1-2011.

CLASS 2—PAINTS

4,119,772. MOBIO LABORATORIES, INC., CARLSBAD, CA. SN 85-253,569. FILED P.R. 2-28-2011; AM. S.R. 1-25-2012.

DYE DOTS

THE MARK CONSISTS OF STANDARD CHARACTERS WITHOUT CLAIM TO ANY PARTICULAR FONT, STYLE, SIZE, OR COLOR.

NO CLAIM IS MADE TO THE EXCLUSIVE RIGHT TO USE "DYE", APART FROM THE MARK AS SHOWN.

FOR LIQUID SOLUBLE DYES FOR PREPARING SCIENTIFIC SAMPLES IN THE FIELD OF MOLECULAR BIOLOGY (U.S. CLS. 6, 11 AND 16).

FIRST USE 2-23-2011; IN COMMERCE 2-23-2011.

CLASS 3—COSMETICS AND CLEANING PREPARATIONS

CLASS 3—(Continued).

4,119,800. BURT'S BEES, INC., DURHAM, NC. SN 85-305,929. FILED P.R. 4-27-2011; AM. S.R. 2-1-2012.

CHERRY BLOSSOM & ALMOND MILK

THE MARK CONSISTS OF STANDARD CHARACTERS WITHOUT CLAIM TO ANY PARTICULAR FONT, STYLE, SIZE, OR COLOR.

FOR BODY LOTIONS; BODY WASH; HAIR SHAMPOOS AND CONDITIONERS; HAND CREAMS; HAND SOAPS; NON-MEDICATED SKIN CARE PREPARATION, NAMELY, BODY MIST; PERFUME; SHOWER GELS (U.S. CLS. 1, 4, 6, 50, 51 AND 52).
FIRST USE 11-16-2011; IN COMMERCE 11-16-2011.

CLASS 5—PHARMACEUTICALS

4,119,774. DR. GOOD CARBS, INC., SOLON, OH. SN 85-270,842. FILED P.R. 3-18-2011; AM. S.R. 2-3-2012.

GOOD GREENS

THE MARK CONSISTS OF STANDARD CHARACTERS WITHOUT CLAIM TO ANY PARTICULAR FONT, STYLE, SIZE, OR COLOR.

FOR DIETARY AND NUTRITIONAL SUPPLEMENTS; NUTRITIONAL SUPPLEMENTS IN THE FORM OF POWDERS, BEVERAGES, BARS, COOKIES, AND FOOD PRODUCTS (U.S. CLS. 6, 18, 44, 46, 51 AND 52).
FIRST USE 6-30-2011; IN COMMERCE 6-30-2011.

4,119,785. HYPER NETWORK SOLUTIONS, LLC, WEST PALM BEACH, FL. SN 85-295,700. FILED P.R. 4-14-2011; AM. S.R. 1-18-2012.

GOURMET CHEWABLE

THE MARK CONSISTS OF STANDARD CHARACTERS WITHOUT CLAIM TO ANY PARTICULAR FONT, STYLE, SIZE, OR COLOR.

NO CLAIM IS MADE TO THE EXCLUSIVE RIGHT TO USE "CHEWABLE", APART FROM THE MARK AS SHOWN. FOR DIETARY AND NUTRITIONAL SUPPLEMENTS (U.S. CLS. 6, 18, 44, 46, 51 AND 52).
FIRST USE 9-1-2011; IN COMMERCE 9-1-2011.

CLASS 5—(Continued).

4,119,792. HYPER NETWORK SOLUTIONS, LLC, WEST PALM BEACH, FL. SN 85-301,798. FILED P.R. 4-21-2011; AM. S.R. 1-18-2012.

GOURMET DIGEST

THE MARK CONSISTS OF STANDARD CHARACTERS WITHOUT CLAIM TO ANY PARTICULAR FONT, STYLE, SIZE, OR COLOR.

FOR DIETARY AND NUTRITIONAL SUPPLEMENTS (U.S. CLS. 6, 18, 44, 46, 51 AND 52).
FIRST USE 9-1-2011; IN COMMERCE 9-1-2011.

4,119,793. HYPER NETWORK SOLUTIONS, LLC, WEST PALM BEACH, FL. SN 85-301,801. FILED P.R. 4-21-2011; AM. S.R. 1-19-2012.

GOURMET DIGESTIVE

THE MARK CONSISTS OF STANDARD CHARACTERS WITHOUT CLAIM TO ANY PARTICULAR FONT, STYLE, SIZE, OR COLOR.

FOR DIETARY AND NUTRITIONAL SUPPLEMENTS (U.S. CLS. 6, 18, 44, 46, 51 AND 52).
FIRST USE 9-1-2011; IN COMMERCE 9-1-2011.

4,119,796. PEROGEN CORPORATION, POMPANO BEACH, FL. SN 85-302,806. FILED P.R. 4-22-2011; AM. S.R. 1-27-2012.

5 · STAGE SLEEP

THE MARK CONSISTS OF STANDARD CHARACTERS WITHOUT CLAIM TO ANY PARTICULAR FONT, STYLE, SIZE, OR COLOR.

FOR DIETARY SUPPLEMENT BEVERAGE FOR AIDING SLEEP; DIETARY SUPPLEMENTAL DRINKS; DIETARY SUPPLEMENTS; DIETARY SUPPLEMENTS FOR HUMAN CONSUMPTION; DIETARY SUPPLEMENTS FOR AIDING SLEEP (U.S. CLS. 6, 18, 44, 46, 51 AND 52).
FIRST USE 3-10-2008; IN COMMERCE 11-28-2009.

CLASS 5—(Continued).

4,119,812. MEZOTRACE CORPORATION, WINNEMUCCA, NV. SN 85-324,253. FILED P.R. 5-18-2011; AM. S.R. 2-8-2012.

WELLINGTON ST

THE MARK CONSISTS OF STANDARD CHARACTERS WITHOUT CLAIM TO ANY PARTICULAR FONT, STYLE, SIZE, OR COLOR.

FOR MINERAL SUPPLEMENTS WITH TRACE ELEMENTS (U.S. CLS. 6, 18, 44, 46, 51 AND 52).
FIRST USE 1-4-2012; IN COMMERCE 1-4-2012.

4,119,882. NRGNOVATIONS, LLC, SKANEATELES, NY. SN 85-455,305. FILED 10-25-2011.

Running Food

THE MARK CONSISTS OF STANDARD CHARACTERS WITHOUT CLAIM TO ANY PARTICULAR FONT, STYLE, SIZE, OR COLOR.

NO CLAIM IS MADE TO THE EXCLUSIVE RIGHT TO USE "FOOD", APART FROM THE MARK AS SHOWN.
FOR DIETARY FOOD SUPPLEMENTS (U.S. CLS. 6, 18, 44, 46, 51 AND 52).
FIRST USE 2-22-2010; IN COMMERCE 4-5-2010.

CLASS 6—METAL GOODS

4,119,839. COOL BY 10° LLC, GREENFIELD, MO. SN 85-401,405. FILED P.R. 8-18-2011; AM. S.R. 1-26-2012.

EZ TO SHORE

THE MARK CONSISTS OF STANDARD CHARACTERS WITHOUT CLAIM TO ANY PARTICULAR FONT, STYLE, SIZE, OR COLOR.

FOR METAL RAMPS, NAMELY, FOLDABLE METAL RAMPS THAT SERVE AS A WALKWAY FOR PEOPLE TO TRAVEL BETWEEN A BOAT AND THE SHORE OF A BODY OF WATER (U.S. CLS. 2, 12, 13, 14, 23, 25 AND 50).
FIRST USE 8-30-2011; IN COMMERCE 8-30-2011.

CLASS 7—MACHINERY**CLASS 7—(Continued).**

4,119,757. ENGINEERED ARRESTING SYSTEMS CORPORATION, LOGAN TOWNSHIP, NJ. SN 85-150,706. FILED P.R. 10-12-2010; AM. S.R. 1-18-2012.

SMARTARREST

THE MARK CONSISTS OF STANDARD CHARACTERS WITHOUT CLAIM TO ANY PARTICULAR FONT, STYLE, SIZE, OR COLOR.

FOR A GROUND-BASED AIRCRAFT BRAKING SYSTEM COMPRISED OF FRICTION BRAKES, SHEAVES, TAPE, AND ELECTRONIC CONTROLS (U.S. CLS. 13, 19, 21, 23, 31, 34 AND 35).
FIRST USE 10-1-2011; IN COMMERCE 10-1-2011.

4,119,775. PITONYAK MACHINERY CORPORATION, CARLISLE, AR. SN 85-278,989. FILED P.R. 3-28-2011; AM. S.R. 1-20-2012.

TUMBLER

THE MARK CONSISTS OF STANDARD CHARACTERS WITHOUT CLAIM TO ANY PARTICULAR FONT, STYLE, SIZE, OR COLOR.

FOR FARM AND AGRICULTURAL EQUIPMENT, NAMELY A FURROW ROLLER FOR CRUMBLING DIRT CLODS AND FOR SIMULTANEOUSLY CONFIGURING, PREPARING, AND COMPACTING SEED BEDS, SHAPING FURROWS, AND FORMING DRAINAGE AND IRRIGATION TRENCHES IN A SINGLE PASS (U.S. CLS. 13, 19, 21, 23, 31, 34 AND 35).
FIRST USE 2-28-2011; IN COMMERCE 6-29-2011.

4,119,819. HORSCH MASCHINEN GMBH, SCHWANDORF, FED REP GERMANY. SN 85-342,891. FILED P.R. 6-10-2011; AM. S.R. 2-1-2012.

LEEB

THE MARK CONSISTS OF STANDARD CHARACTERS WITHOUT CLAIM TO ANY PARTICULAR FONT, STYLE, SIZE, OR COLOR.

CLASS 7—(Continued).

PRIORITY CLAIMED UNDER SEC. 44(D) ON ERPN CMNTY TM OFC APPLICATION NO. 010012268, FILED 6-1-2011, REG. NO. 010012268, DATED 2-11-2011, EXPIRES 1-6-2021.

FOR AGRICULTURAL MACHINES AND MECHANICAL AGRICULTURAL IMPLEMENTS, NAMELY, CULTIVATORS, MANURE SPREADERS, POWER OPERATED SPRAYERS, SOWERS, MOWERS, GRAIN CARTS AND HARVESTERS; AND PARTS OF THE AFORESAID GOODS (U.S. CLS. 13, 19, 21, 23, 31, 34 AND 35).

4,119,832. HOUSTON SERVICE INDUSTRIES, INC., HOUSTON, TX. SN 85-376,548. FILED P.R. 7-20-2011; AM. S.R. 2-2-2012.

ecoTurbo

THE MARK CONSISTS OF STANDARD CHARACTERS WITHOUT CLAIM TO ANY PARTICULAR FONT, STYLE, SIZE, OR COLOR.

FOR POWER OPERATED BLOWERS, NAMELY, INDUSTRIAL BLOWERS AND EXHAUSTERS, CENTRIFUGAL BLOWERS AND EXHAUSTERS, HIGH SPEED TURBO BLOWERS (U.S. CLS. 13, 19, 21, 23, 31, 34 AND 35).

FIRST USE 2-0-2009; IN COMMERCE 2-0-2009.

4,119,833. RICHPOWER INDUSTRIES, INC., WILLIAMSTON, SC. SN 85-376,835. FILED P.R. 7-21-2011; AM. S.R. 1-13-2012.

DURABLE-POWERFUL-VERSATILE

THE MARK CONSISTS OF STANDARD CHARACTERS WITHOUT CLAIM TO ANY PARTICULAR FONT, STYLE, SIZE, OR COLOR.

FOR HAND-HELD POWER DRIVEN GRINDERS; POWER OPERATED POLISHERS; ELECTRIC SANDERS; ELECTRIC LAWN, HEDGE AND GRASS TRIMMERS; ELECTRIC TABLE TOP AND HAND-HELD DRILLS; POWER OPERATED CUT OFF TOOLS; POWER OPERATED SAWS; POWER OPERATED SHEARS; POWER OPERATED METAL NIBBLER TOOL; POWER OPERATED RIVET SHAVERS; POWER OPERATED SCREW DRIVERS; ELECTRIC POWERED NUT AND SOCKET DRIVERS; ELECTRIC NUT RUNNERS; POWER TOOLS, NAMELY, ROUTERS; POWER-OPERATED RATCHET AND IMPACT WRENCHES; ELECTRIC RIVET AND IMPACT HAMMERS; AIR POWERED STALL BAR ASSEMBLY TOOL (U.S. CLS. 13, 19, 21, 23, 31, 34 AND 35).

FIRST USE 2-6-2008; IN COMMERCE 2-6-2008.

CLASS 8—HAND TOOLS**CLASS 8—(Continued).**

4,119,845. GREER, WILLIAM A, RUCKERSVILLE, VA. AND GREER, DEDREA A, RUCKERSVILLE, VA. SN 85-408,287. FILED P.R. 8-26-2011; AM. S.R. 1-19-2012.

The American Peg Loom

THE MARK CONSISTS OF STANDARD CHARACTERS WITHOUT CLAIM TO ANY PARTICULAR FONT, STYLE, SIZE, OR COLOR.

NO CLAIM IS MADE TO THE EXCLUSIVE RIGHT TO USE "PEG LOOM", APART FROM THE MARK AS SHOWN, FOR HAND-OPERATED LOOM FOR HANDWEAVING (U.S. CLS. 23, 28 AND 44).

FIRST USE 3-31-2011; IN COMMERCE 3-31-2011.

4,119,890. AMES TRUE TEMPER, INC., CAMP HILL, PA. SN 85-506,306. FILED P.R. 12-30-2011; AM. S.R. 2-3-2012.

ErgoLoop

THE MARK CONSISTS OF STANDARD CHARACTERS WITHOUT CLAIM TO ANY PARTICULAR FONT, STYLE, SIZE, OR COLOR.

FOR MANUALLY OPERATED HAND TOOLS, NAMELY, HAND TROWELS, CULTIVATORS, TRANSPLANTERS, WEEDERS, NAMELY, WEEDING FORKS, DIGGING FORKS, AND SOIL SCOOPS, NAMELY, FERTILIZER SCOOPS, SPADES, SHOVELS (U.S. CLS. 23, 28 AND 44).

FIRST USE 12-0-2010; IN COMMERCE 12-0-2010.

CLASS 9—ELECTRICAL AND SCIENTIFIC APPARATUS

4,119,749. ASK US MEDIA LLC, KIRKLAND, WA. SN 85-116,586. FILED P.R. 8-26-2010; AM. S.R. 4-29-2011.

SHOW APP

THE MARK CONSISTS OF STANDARD CHARACTERS WITHOUT CLAIM TO ANY PARTICULAR FONT, STYLE, SIZE, OR COLOR.

CLASS 9—(Continued).

NO CLAIM IS MADE TO THE EXCLUSIVE RIGHT TO USE "APP", APART FROM THE MARK AS SHOWN.

FOR COMPUTER SOFTWARE FOR UPLOAD, STORAGE, RETRIEVAL, DOWNLOAD, STREAMING, TRANSMISSION AND DELIVERY OF DIGITAL CONTENT; DOWNLOADABLE AND STREAMABLE AUDIO FILES, MULTIMEDIA FILES, AUDIO MATERIAL, AND VIDEO MATERIAL FEATURING HIGH PROFILE ENTERTAINERS, EXTREME ACTION SPORTS, TOP MODELS FROM AROUND THE WORLD, INDEPENDENT MUSIC AND ARTISTS, INFORMATION ON THE ENVIRONMENT, ENVIRONMENTAL BRANDS, FAITH, MOTIVATION AND INSPIRATION PRAYERS, WOMEN'S AND MEN'S LIFESTYLE; DOWNLOADABLE AND STREAMABLE FILMS AND MOVIES FEATURING HIGH PROFILE ENTERTAINERS, EXTREME ACTION SPORTS, TOP MODELS FROM AROUND THE WORLD, INDEPENDENT MUSIC AND ARTISTS, INFORMATION ON THE ENVIRONMENT, ENVIRONMENTAL BRANDS, FAITH, MOTIVATION AND INSPIRATION PRAYERS, WOMEN'S AND MEN'S LIFESTYLE, ALL PROVIDED VIA A VIDEO-ON-DEMAND SERVICE (U.S. CLS. 21, 23, 26, 36 AND 38).

FIRST USE 2-6-2012; IN COMMERCE 2-6-2012.

4,119,754. ROYAL NATIONAL INSTITUTE OF BLIND PEOPLE, LONDON, UNITED KINGDOM. SN 85-144,507. FILED P.R. 10-4-2010; AM. S.R. 12-8-2011.

iGlasses

THE MARK CONSISTS OF STANDARD CHARACTERS WITHOUT CLAIM TO ANY PARTICULAR FONT, STYLE, SIZE, OR COLOR.

PRIORITY CLAIMED UNDER SEC. 44(D) ON ERP CMNTY TM OFC APPLICATION NO. 009382491, FILED 9-17-2010, REG. NO. 009382491, DATED 3-1-2011, EXPIRES 9-17-2020.

FOR ULTRASONIC VIBRATION MOBILITY APPARATUS FOR USE BY BLIND PEOPLE AROUND THE EYES AND USED WITH A CANE OR DOG TO DETECT OBSTACLES IN THE PATH OF THE VISUALLY IMPAIRED (U.S. CLS. 21, 23, 26, 36 AND 38).

4,119,756. CONTEMPORARY CONTROL SYSTEMS, INC., DOWNERS GROVE, IL. SN 85-146,657. FILED P.R. 10-6-2010; AM. S.R. 2-2-2012.

BASAUTOMATION

THE MARK CONSISTS OF STANDARD CHARACTERS WITHOUT CLAIM TO ANY PARTICULAR FONT, STYLE, SIZE, OR COLOR.

FOR COMPUTERIZED COMMUNICATION NETWORK DEVICES, NAMELY, HUBS, ADAPTERS, SWITCHES, TRANSCEIVERS, NETWORK ANALYZERS, GATEWAYS FOR LINKING INDUSTRIAL AND PLANT-WIDE NETWORKS TO FACTORY MACHINERY AND PROCESS DEVICES (U.S. CLS. 21, 23, 26, 36 AND 38).

FIRST USE 9-13-2010; IN COMMERCE 9-13-2010.

CLASS 9—(Continued).

4,119,776. THE NATIONAL RENTERS ASSOCIATION, INC., SEGUIN, TX. SN 85-280,530. FILED P.R. 3-29-2011; AM. S.R. 3-29-2011.

NATIONAL RENTERS ASSOCIATION

THE MARK CONSISTS OF STANDARD CHARACTERS WITHOUT CLAIM TO ANY PARTICULAR FONT, STYLE, SIZE, OR COLOR.

FOR DOWNLOADABLE ELECTRONIC DATA, NAMELY, FORMS RELATING TO RENTING RESIDENTIAL PROPERTY (U.S. CLS. 21, 23, 26, 36 AND 38).

FIRST USE 5-12-2010; IN COMMERCE 5-12-2010.

4,119,806. ZUFFA, LLC, LAS VEGAS, NV. SN 85-317,304. FILED P.R. 5-10-2011; AM. S.R. 2-15-2012.

FIGHT LIBRARY

THE MARK CONSISTS OF STANDARD CHARACTERS WITHOUT CLAIM TO ANY PARTICULAR FONT, STYLE, SIZE, OR COLOR.

FOR AUDIO AND VIDEO RECORDINGS FEATURING SPORTS AND ENTERTAINMENT; DOWNLOADABLE AUDIO AND VIDEO RECORDINGS FEATURING SPORTS AND ENTERTAINMENT VIA GLOBAL COMMUNICATION NETWORK AND VIDEO-ON-DEMAND SERVICE (U.S. CLS. 21, 23, 26, 36 AND 38).

FIRST USE 2-0-2011; IN COMMERCE 2-0-2011.

4,119,817. CADILLAC JACK, INC., DULUTH, GA. SN 85-335,783. FILED P.R. 6-1-2011; AM. S.R. 1-30-2012.

BONUS CHOICE

THE MARK CONSISTS OF STANDARD CHARACTERS WITHOUT CLAIM TO ANY PARTICULAR FONT, STYLE, SIZE, OR COLOR.

FOR GAMING DEVICES, NAMELY, GAMING MACHINES, SLOT MACHINES, BINGO MACHINES, WITH OR WITHOUT VIDEO OUTPUT; GAMING SOFTWARE THAT GENERATES OR DISPLAYS WAGER OUTCOMES OF GAMING MACHINES (U.S. CLS. 21, 23, 26, 36 AND 38).

FIRST USE 11-6-2011; IN COMMERCE 11-6-2011.

CLASS 9—(Continued).

4,119,818. BRIGHTWELL PAYMENTS, INC., ATLANTA, GA.
SN 85-342,880. FILED P.R. 6-10-2011; AM. S.R. 1-26-2012.

Brightwell Payments

THE MARK CONSISTS OF STANDARD CHARACTERS WITHOUT CLAIM TO ANY PARTICULAR FONT, STYLE, SIZE, OR COLOR.

NO CLAIM IS MADE TO THE EXCLUSIVE RIGHT TO USE "PAYMENTS", APART FROM THE MARK AS SHOWN.

FOR MAGNETICALLY ENCODED PREPAID CARDS FOR MAKING PAYMENTS AND ACCESSING CASH AT AN AUTOMATED TELLER MACHINE (ATM), NAMELY, GIFT CARDS, GENERAL PURPOSE RELOADABLE PREPAID DEBIT CARDS, PAYROLL CARDS, LOYALTY, AWARD AND PROMOTIONAL INCENTIVE CARDS, VIRTUAL CARDS IN THE NATURE OF DOWNLOADABLE SOFTWARE USED TO PROCESS, COLLECT, STORE, AND RETRIEVE DATA, MONEY TRANSFER CARDS AND FLEXIBLE SPENDING ACCOUNT CARDS (U.S. CLS. 21, 23, 26, 36 AND 38).

FIRST USE 1-9-2012; IN COMMERCE 1-9-2012.

4,119,820. OCZ TECHNOLOGY GROUP, INC., SAN JOSE, CA. SN 85-346,414. FILED P.R. 6-15-2011; AM. S.R. 1-30-2012.

SUPERSCALE

THE MARK CONSISTS OF STANDARD CHARACTERS WITHOUT CLAIM TO ANY PARTICULAR FONT, STYLE, SIZE, OR COLOR.

FOR NON-VOLATILE MASS STORAGE DEVICE FOR USE WITH COMPUTERS IN THE NATURE OF A NONVOLATILE STORAGE MEDIUM THAT EMPLOYS INTEGRATED CIRCUITS (U.S. CLS. 21, 23, 26, 36 AND 38).

FIRST USE 1-1-2012; IN COMMERCE 1-1-2012.

CLASS 9—(Continued).

4,119,834. METRO MOMS NETWORK, L.L.C., HOBOKEN, NJ. SN 85-381,900. FILED P.R. 7-27-2011; AM. S.R. 2-3-2012.

Metro Moms Network

THE MARK CONSISTS OF STANDARD CHARACTERS WITHOUT CLAIM TO ANY PARTICULAR FONT, STYLE, SIZE, OR COLOR.

FOR ELECTRONIC PUBLICATIONS, NAMELY, E-ZINES FEATURING MOM-OWNED BUSINESSES AND SERVICES THAT HELP EASE THE BURDENS OF URBAN PARENTING. PROVIDING BOTH CAREER TOOLS AND INSIDER PARENTING TIPS FOR METRO MOMS AND DADS RECORDED ON COMPUTER MEDIA (U.S. CLS. 21, 23, 26, 36 AND 38).

FIRST USE 6-27-2011; IN COMMERCE 6-27-2011.

4,119,846. THE BIOMECHANICS LLC, SAN DIEGO, CA. SN 85-408,632. FILED P.R. 8-26-2011; AM. S.R. 1-13-2012.

The BioMechanics Method

THE MARK CONSISTS OF STANDARD CHARACTERS WITHOUT CLAIM TO ANY PARTICULAR FONT, STYLE, SIZE, OR COLOR.

FOR PRE-RECORDED CDS AND DVDS IN THE FIELD OF HEALTH AND FITNESS; DOWNLOADABLE MULTIMEDIA AND FILES, TEXT FILES AND WRITTEN DOCUMENTS FEATURING INFORMATION IN THE FIELD OF HEALTH AND FITNESS (U.S. CLS. 21, 23, 26, 36 AND 38).

FIRST USE 11-17-2008; IN COMMERCE 5-27-2009.

4,119,873. AJT SYSTEMS, INC., FORT LAUDERDALE, FL. SN 85-446,181. FILED P.R. 10-13-2011; AM. S.R. 2-17-2012.

PROPERTY LINK

THE MARK CONSISTS OF STANDARD CHARACTERS WITHOUT CLAIM TO ANY PARTICULAR FONT, STYLE, SIZE, OR COLOR.

FOR COMPUTER SOFTWARE USED IN LIVE BROADCAST AND TELEVISION TO CREATE LIVE ON AIR GRAPHICS THAT CAN BE MANIPULATED (U.S. CLS. 21, 23, 26, 36 AND 38).

FIRST USE 12-1-2009; IN COMMERCE 1-1-2010.

CLASS 9—(Continued).

4,119,876. DIGITAL BUSINESS SOLUTIONS, INC., IRVINE, CA. SN 85-447,268. FILED 10-13-2011.

CLASS 10—(Continued).

4,119,747. TRANSCATHETER TECHNOLOGIEES GMBH, 93053 REGENSBURG, FED REP GERMANY. SN 85-107,330. FILED P.R. 8-13-2010; AM. S.R. 6-6-2011.

DIGITAL RX

THE MARK CONSISTS OF STANDARD CHARACTERS WITHOUT CLAIM TO ANY PARTICULAR FONT, STYLE, SIZE, OR COLOR.

FOR COMPUTER SOFTWARE FOR CONTROLLING AND MANAGING PATIENT MEDICAL INFORMATION; MEDICAL SOFTWARE FOR PHARMACY RETAIL INDUSTRY, NAMELY, FILLING PRESCRIPTIONS AND MANAGING PATIENT INFORMATION AND (U.S. CLS. 21, 23, 26, 36 AND 38).

FIRST USE 7-1-2006; IN COMMERCE 7-1-2006.

ZERO PRESSURE CRIMPING

THE MARK CONSISTS OF STANDARD CHARACTERS WITHOUT CLAIM TO ANY PARTICULAR FONT, STYLE, SIZE, OR COLOR.

PRIORITY CLAIMED UNDER SEC. 44(D) ON ERPN CMNTY TM OFC APPLICATION NO. 008887143, FILED 2-16-2010, REG. NO. 008887143, DATED 8-2-2010, EXPIRES 2-16-2020.

NO CLAIM IS MADE TO THE EXCLUSIVE RIGHT TO USE "CRIMPING", APART FROM THE MARK AS SHOWN.

FOR SURGICAL, MEDICAL, DENTAL AND VETERINARY APPARATUS AND INSTRUMENTS, NAMELY, HEART VALVE PROSTHESIS; ARTIFICIAL LIMBS, EYES AND TEETH; SUTURE MATERIALS; SURGICAL APPARATUS AND INSTRUMENTS, NAMELY, CATHETERS, STENTS, AND HEART VALVE PROSTHESIS; SURGICAL IMPLANTS COMPRISING ARTIFICIAL MATERIALS; BOUGIES; HEART PACEMAKERS; CANNULAE; CATHETERS; ARTIFICIAL HEART VALVES; MEDICAL INSTRUMENTS, NAMELY, HEART VALVE PROSTHESIS, CATHETERS, CANNULAE, AND STENTS; SURGICAL VASCULAR SUPPORTS (U.S. CLS. 26, 39 AND 44).

CLASS 10—MEDICAL APPARATUS

4,119,742. TYCO HEALTHCARE GROUP LP, NEW HAVEN, CT. SN 85-023,031. FILED 4-26-2010.

4,119,830. ARMSTRONG MEDICAL LIMITED, COLERAINE BT52 1BS, UNITED KINGDOM. SN 85-369,314. FILED P.R. 7-12-2011; AM. S.R. 1-31-2012.

**SPIRALE**

THE COLOR(S) BLUE IS/ARE CLAIMED AS A FEATURE OF THE MARK.

THE MARK CONSISTS OF THE COLOR BLUE APPEARING ON THE SURFACE OF THE GOODS. THE BROKEN LINES ARE INTENDED ONLY TO SHOW THE POSITION OF THE MARK AND ARE NOT CLAIMED AS PART OF THE MARK.

FOR SURGICAL APPARATUS AND INSTRUMENTS FOR MEDICAL USE; SURGICAL DEVICES AND INSTRUMENTS; MEDICAL APPARATUS, NAMELY, SURGICAL PORTS FOR ACCESSING THE BODY DURING SURGERY (U.S. CLS. 26, 39 AND 44).

FIRST USE 10-5-2008; IN COMMERCE 10-5-2008.

THE MARK CONSISTS OF STANDARD CHARACTERS WITHOUT CLAIM TO ANY PARTICULAR FONT, STYLE, SIZE, OR COLOR.

THE ENGLISH TRANSLATION OF "SPIRALE" FROM CERTAIN ROMANCE LANGUAGES IN THE MARK IS "SPIRAL".

FOR COLLAPSIBLE VOLUMIZING CHAMBER FOR AEROSOL DRUG DELIVERY TO PATIENTS UNDER ANESTHESIA OR INTENSIVE CARE (U.S. CLS. 26, 39 AND 44).

FIRST USE 10-31-2010; IN COMMERCE 10-31-2010.

CLASS 10—(Continued).

4,119,843. MATSUM, INC., LOS ALAMITOS, CA. SN 85-405,774. FILED P.R. 8-24-2011; AM. S.R. 1-19-2012.

FIRheat

THE MARK CONSISTS OF STANDARD CHARACTERS WITHOUT CLAIM TO ANY PARTICULAR FONT, STYLE, SIZE, OR COLOR.

FOR HEATING PADS FOR MEDICAL PURPOSES (U.S. CLS. 26, 39 AND 44).

FIRST USE 3-1-2011; IN COMMERCE 3-1-2011.

**CLASS 11—ENVIRONMENTAL CONTROL AP-
PARATUS**

4,119,748. LIQUID BREAKER, LLC, CARLSBAD, CA. SN 85-110,531. FILED P.R. 8-18-2010; AM. S.R. 1-6-2012.

THE GREEN CARTRIDGE

THE MARK CONSISTS OF STANDARD CHARACTERS WITHOUT CLAIM TO ANY PARTICULAR FONT, STYLE, SIZE, OR COLOR.

FOR URINAL CARTRIDGES AND RELATED COMPONENTS (U.S. CLS. 13, 21, 23, 31 AND 34).

FIRST USE 2-24-2011; IN COMMERCE 2-24-2011.

4,119,842. MAN-D-TEC, INC., SCOTTSDALE, AZ. SN 85-405,577. FILED P.R. 8-24-2011; AM. S.R. 2-1-2012.

ILLUMINATOR

THE MARK CONSISTS OF STANDARD CHARACTERS WITHOUT CLAIM TO ANY PARTICULAR FONT, STYLE, SIZE, OR COLOR.

FOR LED LIGHT STRIPS FOR ELEVATOR INTERIOR ILLUMINATION (U.S. CLS. 13, 21, 23, 31 AND 34).

FIRST USE 9-8-2011; IN COMMERCE 9-8-2011.

CLASS 11—(Continued).

4,119,858. BRILLIANCE LED, LLC, CAREFREE, AZ. SN 85-424,387. FILED P.R. 9-16-2011; AM. S.R. 1-27-2012.



THE COLOR(S) BLUE IS/ARE CLAIMED AS A FEATURE OF THE MARK.

THE MARK CONSISTS OF THE COLOR BLUE AS APPLIED TO A PORTION OF THE OUTER HOUSING OF LED LIGHT BULBS. THE COLOR WHITE AS WELL AS THE DOTTED OUTLINE OF THE GOODS IS INTENDED TO SHOW THE POSITION OF THE MARK ON THE GOODS AND IS NOT PART OF THE MARK.

FOR LED (LIGHT EMITTING DIODE) LIGHTING FIXTURES; LED (LIGHT EMITTING DIODES) LIGHTING FIXTURES FOR USE IN DISPLAY, COMMERCIAL, INDUSTRIAL, RESIDENTIAL, AND ARCHITECTURAL ACCENT LIGHTING APPLICATIONS; LED AND HID LIGHT FIXTURES; LED LANDSCAPE LIGHTS; LED LIGHT ASSEMBLIES FOR STREET LIGHTS, SIGNS, COMMERCIAL LIGHTING, AUTOMOBILES, BUILDINGS, AND OTHER ARCHITECTURAL USES; LED LIGHT BULBS; LED LIGHTING FIXTURES FOR INDOOR AND OUTDOOR LIGHTING APPLICATIONS (U.S. CLS. 13, 21, 23, 31 AND 34).

FIRST USE 10-1-2010; IN COMMERCE 10-1-2010.

CLASS 12—VEHICLES

4,119,744. DORNIER, CONRADO, 82547 BEUERBERG, FED REP GERMANY. SN 85-039,842. FILED P.R. 5-17-2010; AM. S.R. 2-28-2011.



THE COLOR(S) BLUE, WHITE AND GRAY IS/ARE CLAIMED AS A FEATURE OF THE MARK.

CLASS 12—(Continued).

THE MARK CONSISTS OF A STYLIZED AIRPLANE IN THE COLORS OF BLUE AND WHITE WITH THE WORD "DORNIER" UNDERNEATH THE AIRPLANE IN GRAY.

FOR VEHICLES, APPARATUS FOR LOCOMOTION BY LAND, AIR OR WATER, NAMELY, SEAPLANES, AIRPLANES, AND BOATS; SPARE PARTS FOR SEAPLANES, AIRPLANES AND BOATS (U.S. CLS. 19, 21, 23, 31, 35 AND 44).

FIRST USE 1-24-2011; IN COMMERCE 1-24-2011.

CLASS 16—(Continued).

4,119,777. 1C EUROPE B.V., AMSTERDAM, NETHERLANDS. SN 85-282,800. FILED P.R. 3-31-2011; AM. S.R. 1-5-2012.

CLIFFS OF DOVER

THE MARK CONSISTS OF STANDARD CHARACTERS WITHOUT CLAIM TO ANY PARTICULAR FONT, STYLE, SIZE, OR COLOR.

PRIORITY CLAIMED UNDER SEC. 44(D) ON ERP N CMNTY TM OFC APPLICATION NO. 009785031, FILED 3-4-2011, REG. NO. 009785031, DATED 8-15-2011, EXPIRES 3-4-2021.

FOR PRINTED STRATEGY GUIDES AND MANUALS FOR COMPUTER GAMES; COMIC BOOKS; POSTERS; TRADING CARDS (U.S. CLS. 2, 5, 22, 23, 29, 37, 38 AND 50).

4,119,854. DECK GEAR LLC, VENICE, FL. SN 85-420,088. FILED P.R. 9-12-2011; AM. S.R. 1-4-2012.

DECKGEAR

THE MARK CONSISTS OF STANDARD CHARACTERS WITHOUT CLAIM TO ANY PARTICULAR FONT, STYLE, SIZE, OR COLOR.

FOR BOATS AND STRUCTURAL PARTS THEREFOR; FISH-FIGHTING CHAIRS AFFIXED TO FISHING BOATS; STRUCTURAL PARTS FOR BOATS (U.S. CLS. 19, 21, 23, 31, 35 AND 44).

FIRST USE 5-1-2011; IN COMMERCE 6-1-2011.

4,119,782. COHEN, PHYLLIS, LONDON, UNITED KINGDOM. SN 85-291,687. FILED P.R. 4-11-2011; AM. S.R. 1-18-2012.

FACE LACE

THE MARK CONSISTS OF STANDARD CHARACTERS WITHOUT CLAIM TO ANY PARTICULAR FONT, STYLE, SIZE, OR COLOR.

FOR MAKE UP, NAMELY, MAKE UP DESIGNS CUT FROM VINYL WHICH ADHERE TO THE SKIN TO CREATE ELABORATE MAKE-UP EFFECTS (U.S. CLS. 2, 5, 22, 23, 29, 37, 38 AND 50).

FIRST USE 11-14-2011; IN COMMERCE 11-14-2011.

CLASS 16—PAPER GOODS AND PRINTED MATTER

4,119,764. INTERNATIONAL AIDS SOCIETY-USA, SAN FRANCISCO, CA. SN 85-186,226. FILED P.R. 11-29-2010; AM. S.R. 9-6-2011.

TOPICS IN ANTIVIRAL MEDICINE

THE MARK CONSISTS OF STANDARD CHARACTERS WITHOUT CLAIM TO ANY PARTICULAR FONT, STYLE, SIZE, OR COLOR.

OWNER OF U.S. REG. NO. 2,637,572.

FOR BIOMEDICAL JOURNAL FEATURING REVIEWS, SUMMARIES, AND OTHER RELATED INFORMATION RELEVANT TO THE FIELD OF VIRAL DISEASES AND TREATMENTS (U.S. CLS. 2, 5, 22, 23, 29, 37, 38 AND 50).

FIRST USE 11-0-2011; IN COMMERCE 11-0-2011.

4,119,872. NEW YORK CITY WORLDWIDE MAGAZINE (R), NEW YORK, NY. SN 85-446,147. FILED 10-13-2011.

New York Worldwide Fashion Magazine

THE MARK CONSISTS OF STANDARD CHARACTERS WITHOUT CLAIM TO ANY PARTICULAR FONT, STYLE, SIZE, OR COLOR.

OWNER OF U.S. REG. NOS. 3,433,526 AND 3,684,649.

CLASS 16—(Continued).

NO CLAIM IS MADE TO THE EXCLUSIVE RIGHT TO USE "FASHION MAGAZINE", APART FROM THE MARK AS SHOWN.

FOR GENERAL FEATURE MAGAZINE IN THE FIELD OF FASHION; GENERAL FEATURE MAGAZINES; MAGAZINE COLUMNS ABOUT HEALTHY RELATIONS AND FASHION; MAGAZINE DEPARTMENTS IN THE FIELD OF FASHION; MAGAZINE PAPER; MAGAZINE SUPPLEMENTS TO NEWSPAPERS IN THE FIELD OF FASHION; MAGAZINES FEATURING FASHION; MAGAZINES IN THE FIELD OF FASHION; NEWSLETTERS, BROCHURES, AND MAGAZINES IN THE FIELDS OF SECURITIES, OPTIONS, BONDS AND OTHER FINANCIAL INSTRUMENTS; PRINTED MATTER, NAMELY, NEWSPAPERS, PHOTOGRAPHS, MAGAZINES, BOOKS, PRINTED PERIODICALS, NEWSLETTERS, AND BROCHURES ALL IN THE FIELDS OF SECURITIES, OPTIONS AND OTHER FINANCIAL INSTRUMENTS; SYNDICATED MAGAZINE SECTIONS DEALING WITH FASHION, BOOKS, RELATIONSHIPS (U.S. CLS. 2, 5, 22, 23, 29, 37, 38 AND 50).

FIRST USE 12-3-2010; IN COMMERCE 12-3-2010.

CLASS 19—NON-METALLIC BUILDING MATERIALS

4,119,836. G.S. HARRIS CO., INC., OGDEN, UT. SN 85-393,682. FILED P.R. 8-9-2011; AM. S.R. 1-30-2012.

MERRILLSTONE

THE MARK CONSISTS OF STANDARD CHARACTERS WITHOUT CLAIM TO ANY PARTICULAR FONT, STYLE, SIZE, OR COLOR.

FOR MASONRY PRODUCTS, NAMELY CAST STONE VENEERS AND MORTAR MIX (U.S. CLS. 1, 12, 33 AND 50).

FIRST USE 12-0-2011; IN COMMERCE 12-0-2011.

CLASS 20—FURNITURE AND ARTICLES NOT OTHERWISE CLASSIFIED

4,119,840. COOL BY 10° LLC, GREENFIELD, MO. SN 85-401,435. FILED P.R. 8-18-2011; AM. S.R. 1-30-2012.

Cool By 10°

THE MARK CONSISTS OF STANDARD CHARACTERS WITHOUT CLAIM TO ANY PARTICULAR FONT, STYLE, SIZE, OR COLOR.

FOR WINDOW SHADES (U.S. CLS. 2, 13, 22, 25, 32 AND 50).

FIRST USE 7-20-2011; IN COMMERCE 7-20-2011.

CLASS 21—HOUSEWARES AND GLASS**CLASS 21—(Continued).**

4,119,768. RDP PRODUCTIONS, INC., NAPLES, FL. SN 85-235,418. FILED P.R. 2-7-2011; AM. S.R. 2-16-2012.

Triple Divided Skillet

THE MARK CONSISTS OF STANDARD CHARACTERS WITHOUT CLAIM TO ANY PARTICULAR FONT, STYLE, SIZE, OR COLOR.

NO CLAIM IS MADE TO THE EXCLUSIVE RIGHT TO USE "SKILLET", APART FROM THE MARK AS SHOWN. FOR COOKING PANS; SKILLETS (U.S. CLS. 2, 13, 23, 29, 30, 33, 40 AND 50).

FIRST USE 10-1-2008; IN COMMERCE 3-6-2011.

4,119,889. RADIUS CORPORATION, KUTZTOWN, PA. SN 85-466,700. FILED P.R. 11-8-2011; AM. S.R. 2-1-2012.

TOTZ

THE MARK CONSISTS OF STANDARD CHARACTERS WITHOUT CLAIM TO ANY PARTICULAR FONT, STYLE, SIZE, OR COLOR.

FOR TOOTHBRUSHES (U.S. CLS. 2, 13, 23, 29, 30, 33, 40 AND 50).

FIRST USE 9-16-2009; IN COMMERCE 9-16-2009.

CLASS 25—CLOTHING

4,119,738. HOLLENBECK, GREGORY L., MAYWOOD, NJ. SN 77-659,604. FILED P.R. 1-29-2009; AM. S.R. 2-2-2012.

THE BEATNIKS

THE MARK CONSISTS OF STANDARD CHARACTERS WITHOUT CLAIM TO ANY PARTICULAR FONT, STYLE, SIZE, OR COLOR.

FOR SHIRTS (U.S. CLS. 22 AND 39).

FIRST USE 8-29-2010; IN COMMERCE 8-29-2010.

CLASS 25—(Continued).

4,119,771. MECKLENBURG, BRENT O., DBA MECKWEAR, WARD, AR. SN 85-241,140. FILED P.R. 2-14-2011; AM. S.R. 2-14-2012.



THE MARK CONSISTS OF A BACKBONE, A SPINE WITH FIVE VERTEBRATES, AND 8 RIBS WITH ARROWS OFF THE TOP AND BOTTOM RIBS.

FOR BOTTOMS; CLOTHING FOR ATHLETIC USE, NAMELY, PADDED ELBOW COMPRESSION SLEEVES BEING PART OF AN ATHLETIC GARMENT; CLOTHING FOR ATHLETIC USE, NAMELY, PADDED PANTS; CLOTHING FOR ATHLETIC USE, NAMELY, PADDED SHIRTS; CLOTHING FOR ATHLETIC USE, NAMELY, PADDED SHORTS; GLOVES AS CLOTHING; JACKETS; JERSEYS; SHORT SETS; TOPS; TRAVEL CLOTHING CONTAINED IN A PACKAGE COMPRISING REVERSIBLE JACKETS, PANTS, SKIRTS, TOPS AND A BELT OR SCARF; TRIATHLON CLOTHING, NAMELY, TRIATHLON TIGHTS, TRIATHLON SHORTS, TRIATHLON SINGLET, TRIATHLON SHIRTS, TRIATHLON SUITS; UNDERARM CLOTHING SHIELDS; WEARABLE GARMENTS AND CLOTHING, NAMELY, SHIRTS; WOMEN'S CLOTHING, NAMELY, SHIRTS, DRESSES, SKIRTS, BLOUSES (U.S. CLS. 22 AND 39).

FIRST USE 2-1-2009; IN COMMERCE 6-1-2011.

4,119,790. CERTIFIED CAJUN, INC., BUNKIE, LA. SN 85-300,888. FILED P.R. 4-21-2011; AM. S.R. 1-26-2012.



THE MARK CONSISTS OF THE WORDS "CERTIFIED CAJUN" IN VARIOUS FONTS.

FOR ATHLETIC APPAREL, NAMELY, SHIRTS, PANTS, JACKETS, FOOTWEAR, HATS AND CAPS, ATHLETIC UNIFORMS (U.S. CLS. 22 AND 39).

FIRST USE 1-1-2002; IN COMMERCE 1-1-2002.

CLASS 25—(Continued).

4,119,794. THE WILLIAMSBURG GARMENT COMPANY, AKA WILLIAMSBURG GARMENT COMPANY, BROOKLYN, NY. SN 85-302,274. FILED P.R. 4-22-2011; AM. S.R. 4-22-2011.

WILLIAMSBURG Garment Company

NO CLAIM IS MADE TO THE EXCLUSIVE RIGHT TO USE "GARMENT COMPANY", APART FROM THE MARK AS SHOWN.

THE MARK CONSISTS OF INSIDE THE WORD "WILLIAMSBURG", THE LETTER "A" IS SPELLED WITH AN UPSIDE DOWN LETTER "A", FOLLOWED BY THE WORDS "GARMENT COMPANY".

FOR BELTS FOR CLOTHING; BOTTOMS; GLOVES AS CLOTHING; JACKETS; LEATHER BELTS; POCKET SQUARES; TIES; TOPS; TRAVEL CLOTHING CONTAINED IN A PACKAGE COMPRISING REVERSIBLE JACKETS, PANTS, SKIRTS, TOPS AND A BELT OR SCARF; WEARABLE GARMENTS AND CLOTHING, NAMELY, SHIRTS; WOMEN'S CLOTHING, NAMELY, SHIRTS, DRESSES, SKIRTS, BLOUSES (U.S. CLS. 22 AND 39).

FIRST USE 4-13-2011; IN COMMERCE 4-13-2011.

4,119,797. HOTFIT LLC, DBA SKINNYJEANS, NEW YORK, NY. SN 85-303,777. FILED P.R. 4-25-2011; AM. S.R. 2-3-2012.

TEAM COLORS

THE MARK CONSISTS OF STANDARD CHARACTERS WITHOUT CLAIM TO ANY PARTICULAR FONT, STYLE, SIZE, OR COLOR.

FOR JEANS IN THE COLORS OF SCHOOL AND PROFESSIONAL SPORTS TEAMS (U.S. CLS. 22 AND 39).

FIRST USE 1-15-2011; IN COMMERCE 3-15-2011.

4,119,825. DAVE SHEPARD ENTERPRISES, INC., HILLSBORO, OR. SN 85-359,935. FILED P.R. 6-29-2011; AM. S.R. 1-17-2012.

RUBY ROCKET

THE MARK CONSISTS OF STANDARD CHARACTERS WITHOUT CLAIM TO ANY PARTICULAR FONT, STYLE, SIZE, OR COLOR.

FOR T-SHIRTS (U.S. CLS. 22 AND 39).

FIRST USE 8-12-2011; IN COMMERCE 8-12-2011.

CLASS 25—(Continued).

4,119,826. DAVE SHEPARD ENTERPRISES, INC., HILLSBORO, OR. SN 85-359,945. FILED P.R. 6-29-2011; AM. S.R. 1-17-2012.

RANDY ROCKET

THE MARK CONSISTS OF STANDARD CHARACTERS WITHOUT CLAIM TO ANY PARTICULAR FONT, STYLE, SIZE, OR COLOR.

FOR T-SHIRTS (U.S. CLS. 22 AND 39).
FIRST USE 8-12-2011; IN COMMERCE 8-12-2011.

4,119,835. FELDMAN, ROBERT D., DBA BREMELO, BREMERTON, WA. AND FELDMAN, BRITT, DBA BREMELO, BREMERTON, WA. SN 85-382,964. FILED P.R. 7-27-2011; AM. S.R. 1-30-2012.

BREMELO

THE MARK CONSISTS OF STANDARD CHARACTERS WITHOUT CLAIM TO ANY PARTICULAR FONT, STYLE, SIZE, OR COLOR.

THE WORDING "BREMELO" HAS NO MEANING IN A FOREIGN LANGUAGE.

FOR T-SHIRTS (U.S. CLS. 22 AND 39).
FIRST USE 7-28-2003; IN COMMERCE 7-28-2003.

4,119,869. UGALDE, ANDREA, CORONA, CA. SN 85-443,353. FILED P.R. 10-10-2011; AM. S.R. 10-10-2011.

**YOUTH
POSITIEV**

THE MARK CONSISTS OF THE STYLIZED TEXT "YOUTH POSITIEV" WITH THE WORD "YOUTH" ABOVE "POSITIEV", AND THE WORD "POSITIEV" AT AN ANGLE. FOR SHIRTS; SWEAT SHIRTS (U.S. CLS. 22 AND 39). FIRST USE 5-1-2010; IN COMMERCE 9-1-2010.

CLASS 25—(Continued).

4,119,871. TURNER, MINNIE O, DBA LUCUBRATE, SOUTHERN PINES, NC. SN 85-443,726. FILED P.R. 10-10-2011; AM. S.R. 1-30-2012.

LUCUBRATOR

THE MARK CONSISTS OF "LUCUBRATOR" IN BLACK AND AN OWL IN BLACK SITTING ON A BRANCH WITH LEAVES.

FOR CLOTHING, NAMELY, TEE SHIRTS, HATS, BASEBALL CAPS, JACKETS AND SWEATSUITS (U.S. CLS. 22 AND 39).

FIRST USE 6-29-1992; IN COMMERCE 8-11-1992.

CLASS 28—TOYS AND SPORTING GOODS

4,119,791. (JOHN HINDE) JOHN HINDE LTD., BRAY, COUNTY WICKLOW, IRELAND. SN 85-301,372. FILED P.R. 4-21-2011; AM. S.R. 1-30-2012.



THE MARK CONSISTS OF A THREE-DIMENSIONAL CONFIGURATION OF A PLUSH DOLL COMPRISED OF STRING AND FEATURING A LARGE ROUND HEAD WITH TWO EYES AND SMALL BODY.

FOR VOODOO DOLLS (U.S. CLS. 22, 23, 38 AND 50).
FIRST USE 8-15-2009; IN COMMERCE 8-15-2009.

CLASS 28—(Continued).

4,119,799. WILLIAMS, TED E., BOLIVIA, SC. SN 85-305,007.
FILED P.R. 4-26-2011; AM. S.R. 2-6-2012.

Blind Retrieve

THE MARK CONSISTS OF STANDARD CHARACTERS WITHOUT CLAIM TO ANY PARTICULAR FONT, STYLE, SIZE, OR COLOR.

FOR PET TOY PRODUCTS, NAMELY, SINKABLE OR NON-BUOYANT GAME-RETRIEVAL PET TRAINING TOY OBJECTS CAPABLE OF BEING THROWN OR LAUNCHED FOR THE PURPOSE OF TEACHING ANIMALS HOW TO RETRIEVE DOWNED GAME (U.S. CLS. 22, 23, 38 AND 50).

FIRST USE 1-21-2012; IN COMMERCE 1-21-2012.

CLASS 30—STAPLE FOODS

4,119,737. BARRIE HOUSE COFFEE CO., INC., YONKERS, NY. SN 76-704,542. FILED P.R. 9-17-2010; AM. S.R. 6-21-2011.



NO CLAIM IS MADE TO THE EXCLUSIVE RIGHT TO USE THE DESIGN OF COFFEE BEANS, APART FROM THE MARK AS SHOWN.

THE MARK CONSISTS OF A DESIGN OF AN ACCUMULATION OF COFFEE BEANS, APPEARING ON LIGHTLY DOTTED BACKGROUND. THE MATTER SHOWN IN DOTTED LINES SERVES TO SHOW THE POSITION OF THE MARK, AND IS NOT A PORTION OF THE MARK.

FOR ROASTED AND PACKAGED WHOLE BEAN AND GROUND COFFEE (U.S. CL. 46).

FIRST USE 5-16-2011; IN COMMERCE 5-16-2011.

4,119,740. RIPE DESIGN INC, MANHATTAN BEACH, CA.
SN 77-928,492. FILED P.R. 2-4-2010; AM. S.R. 2-15-2012.

Gummi Bear-Rings

THE MARK CONSISTS OF STANDARD CHARACTERS WITHOUT CLAIM TO ANY PARTICULAR FONT, STYLE, SIZE, OR COLOR.

CLASS 30—(Continued).

NO CLAIM IS MADE TO THE EXCLUSIVE RIGHT TO USE "GUMMY", APART FROM THE MARK AS SHOWN.
FOR CANDY (U.S. CL. 46).
FIRST USE 11-1-2009; IN COMMERCE 2-15-2011.

4,119,865. MOUNT RAINIER COFFEE COMPANY, PUYALLUP, WA. SN 85-431,325. FILED P.R. 9-24-2011; AM. S.R. 2-6-2012.

MOUNT RAINIER COFFEE COMPANY

THE MARK CONSISTS OF STANDARD CHARACTERS WITHOUT CLAIM TO ANY PARTICULAR FONT, STYLE, SIZE, OR COLOR.

NO CLAIM IS MADE TO THE EXCLUSIVE RIGHT TO USE "COFFEE COMPANY", APART FROM THE MARK AS SHOWN.

FOR COFFEE (U.S. CL. 46).

FIRST USE 8-1-2010; IN COMMERCE 8-1-2010.

4,119,880. DD IP HOLDER LLC, CANTON, MA. SN 85-449,505. FILED P.R. 10-18-2011; AM. S.R. 2-2-2012.

BIG N' TOASTED

THE MARK CONSISTS OF STANDARD CHARACTERS WITHOUT CLAIM TO ANY PARTICULAR FONT, STYLE, SIZE, OR COLOR.

FOR SANDWICHES (U.S. CL. 46).

FIRST USE 1-30-2012; IN COMMERCE 1-30-2012.

CLASS 32—LIGHT BEVERAGES

4,119,809. LEBLON FOODS, INC., CANASTOTA, NY. SN 85-317,479. FILED P.R. 5-10-2011; AM. S.R. 2-3-2012.

PERU KOLA

THE MARK CONSISTS OF STANDARD CHARACTERS WITHOUT CLAIM TO ANY PARTICULAR FONT, STYLE, SIZE, OR COLOR.

NO CLAIM IS MADE TO THE EXCLUSIVE RIGHT TO USE "KOLA", APART FROM THE MARK AS SHOWN.

FOR FRUIT DRINKS AND JUICES; SOFT DRINKS (U.S. CLS. 45, 46 AND 48).

FIRST USE 1-15-2012; IN COMMERCE 1-15-2012.

CLASS 33—WINES AND SPIRITS

4,119,837. CALEDONIA SPIRITS, INC., HARDWICK, VT. SN 85-398,804. FILED P.R. 8-16-2011; AM. S.R. 2-22-2012.

Caledonia Spirits

THE MARK CONSISTS OF STANDARD CHARACTERS WITHOUT CLAIM TO ANY PARTICULAR FONT, STYLE, SIZE, OR COLOR.

NO CLAIM IS MADE TO THE EXCLUSIVE RIGHT TO USE "SPIRITS", APART FROM THE MARK AS SHOWN. FOR DISTILLED SPIRITS (U.S. CLS. 47 AND 49). FIRST USE 12-28-2010; IN COMMERCE 7-27-2011.

SERVICE MARKS

CLASS 35—ADVERTISING AND BUSINESS

4,119,758. DIVERSIFIED WORKPLACE, LLC, KELLER, TX. SN 85-155,546. FILED P.R. 10-18-2010; AM. S.R. 8-1-2011.

Diversity Recruiting Center

THE MARK CONSISTS OF STANDARD CHARACTERS WITHOUT CLAIM TO ANY PARTICULAR FONT, STYLE, SIZE, OR COLOR.

NO CLAIM IS MADE TO THE EXCLUSIVE RIGHT TO USE "RECRUITING CENTER", APART FROM THE MARK AS SHOWN.

FOR EMPLOYMENT HIRING, RECRUITING, PLACEMENT, STAFFING AND CAREER NETWORKING SERVICES; PROVIDING AN ON-LINE SEARCHABLE DATABASE FEATURING CLASSIFIED AD LISTINGS AND EMPLOYMENT OPPORTUNITIES; PROVIDING AN ON-LINE SEARCHABLE DATABASE FEATURING EMPLOYMENT OPPORTUNITIES AND CONTENT ABOUT EMPLOYMENT (U.S. CLS. 100, 101 AND 102). FIRST USE 7-20-2010; IN COMMERCE 8-1-2010.

4,119,759. STRATAGEN, INC., HOUSTON, TX. SN 85-162,355. FILED P.R. 10-27-2010; AM. S.R. 7-26-2011.

DATA AND NEURAL ANALYSIS

THE MARK CONSISTS OF STANDARD CHARACTERS WITHOUT CLAIM TO ANY PARTICULAR FONT, STYLE, SIZE, OR COLOR.

CLASS 35—(Continued).

NO CLAIM IS MADE TO THE EXCLUSIVE RIGHT TO USE "ANALYSIS", APART FROM THE MARK AS SHOWN.

FOR BUSINESS CONSULTING SERVICES, NAMELY, ECONOMIC ANALYSIS IN THE OIL AND GAS WELL FRACTURING INDUSTRY TO IMPROVE THE ECONOMIC PERFORMANCE OF WELLS (U.S. CLS. 100, 101 AND 102).

FIRST USE 9-15-2010; IN COMMERCE 9-15-2010.

4,119,763. EQUITY EVENTS GROUP, DBA BIG GAME GEAR, HALLETTSVILLE, TX. SN 85-177,907. FILED P.R. 11-16-2010; AM. S.R. 10-27-2011.

Big Game Gear

THE MARK CONSISTS OF STANDARD CHARACTERS WITHOUT CLAIM TO ANY PARTICULAR FONT, STYLE, SIZE, OR COLOR.

NO CLAIM IS MADE TO THE EXCLUSIVE RIGHT TO USE "GEAR", APART FROM THE MARK AS SHOWN.

FOR ONLINE RETAIL STORE SERVICES FEATURING HUNTING, MARINE, FISHING, TACTICAL, AND CAMPING GEAR, AND ISSUING GIFT CERTIFICATES WHICH MAY THEN BE REDEEMED FOR GOODS OR SERVICES (U.S. CLS. 100, 101 AND 102).

FIRST USE 10-25-2010; IN COMMERCE 10-25-2010.

CLASS 35—(Continued).

4,119,765. INTERNATIONAL DATA GROUP, INC., FRAMINGHAM, MA. SN 85-198,084. FILED P.R. 12-15-2010; AM. S.R. 1-27-2012.

TECH MEDIA EXCHANGE

THE MARK CONSISTS OF STANDARD CHARACTERS WITHOUT CLAIM TO ANY PARTICULAR FONT, STYLE, SIZE, OR COLOR.

FOR INTERNET ADVERTISING SERVICES; MANAGING A PLATFORM FOR THE BUYING AND SELLING OF INTERNET BASED ADVERTISING; PROVIDING ONLINE EXCHANGES AND ONLINE AUCTIONS FOR BUYING AND SELLING DIGITAL ADVERTISING; ADVERTISING SERVICES FOR MATCHING BUYERS AND SELLERS OF ADVERTISING, FOR TRACKING ADVERTISING PERFORMANCE, FOR MANAGING, DISTRIBUTING AND SERVING ADVERTISING, FOR ANALYZING ADVERTISING DATA, FOR REPORTING ADVERTISING DATA, AND FOR OPTIMIZING ADVERTISING PERFORMANCE; ENABLING AND CONTRACTING WITH DEMAND SITE PLATFORMS (DSPS), REAL TIME BIDDING PLATFORMS (RTBS), AGENCY TRADING DESKS (ATDS), AND OTHER ADVERTISING AGGREGATION AND BUYING PLATFORMS TO BID ON AND PURCHASE ONLINE AD SPACE, ENABLING THEM TO USE DATA AND OTHER INVENTORY TARGETING TECHNOLOGIES TO BUY SPECIFIC INVENTORY; ENABLING AND CONTRACTING WITH INTERNET WEBSITES, INTERNET AD NETWORKS, PUBLISHER NETWORKS, SYNDICATION NETWORKS, SUPPLY SIDE PLATFORMS (SSPS), ONLINE AD EXCHANGES, AND OTHER SOURCES OF INTERNET AD INVENTORY TO HAVE ADVERTISING BUYERS BID AND PURCHASE THEIR INTERNET INVENTORY THROUGH AN EXCHANGE PLATFORM (U.S. CLS. 100, 101 AND 102).

FIRST USE 3-31-2011; IN COMMERCE 3-31-2011.

4,119,767. KEICH, DENNIS, TEMECULA, CA. SN 85-225,843. FILED P.R. 1-25-2011; AM. S.R. 9-9-2011.

VERANDA FURNISHINGS

THE MARK CONSISTS OF STANDARD CHARACTERS WITHOUT CLAIM TO ANY PARTICULAR FONT, STYLE, SIZE, OR COLOR.

NO CLAIM IS MADE TO THE EXCLUSIVE RIGHT TO USE "FURNISHINGS", APART FROM THE MARK AS SHOWN.

FOR ONLINE RETAIL STORE FEATURING INTERIOR AND OUTDOOR FURNITURE AND ACCESSORIES (U.S. CLS. 100, 101 AND 102).

FIRST USE 10-13-2010; IN COMMERCE 3-1-2011.

CLASS 35—(Continued).

4,119,778. SETILI & ASSOCIATES, LLC, ATLANTA, GA. SN 85-286,081. FILED P.R. 4-5-2011; AM. S.R. 1-26-2012.

STRATEGIC AGILITY

THE MARK CONSISTS OF STANDARD CHARACTERS WITHOUT CLAIM TO ANY PARTICULAR FONT, STYLE, SIZE, OR COLOR.

FOR BUSINESS CONSULTING SERVICES; PROVIDING BUSINESS CONFERENCES (U.S. CLS. 100, 101 AND 102).

FIRST USE 1-0-2011; IN COMMERCE 3-11-2011.

4,119,780. VISIBLE MEASURES CORP., BOSTON, MA. SN 85-287,122. FILED P.R. 4-5-2011; AM. S.R. 1-9-2012.

Earned Media Network

THE MARK CONSISTS OF STANDARD CHARACTERS WITHOUT CLAIM TO ANY PARTICULAR FONT, STYLE, SIZE, OR COLOR.

FOR PROVIDING AN ONLINE ADVERTISING NETWORK THAT SPECIALIZES IN WEB USER TARGETING, CUSTOMIZED CONTEXTUAL TARGETING AND ADVERTISING OPTIMIZATION FOR ONLINE ADVERTISERS AND PUBLISHERS; ONLINE ADVERTISING ON COMPUTER COMMUNICATIONS NETWORKS DELIVERED TO INTERNET-CONNECTED SMART PHONES, TABLETS, SET-TOP BOXES AND COMPUTERS, NAMELY, PROVIDING AN INTERNET-BASED ADVERTISING NETWORK THAT CONNECTS ONLINE ADVERTISERS WITH ONLINE PUBLISHERS OF VIDEO CONTENT; ONLINE ADVERTISING AND MARKETING SERVICES, NAMELY, PROVIDING AN ONLINE ADVERTISING NETWORK TO PROMOTE THE GOODS AND SERVICES OF OTHERS BY DISSEMINATING VIDEO CLIPS AND VIDEO CONTENT OVER THE INTERNET AND COMPUTER COMMUNICATIONS NETWORKS DELIVERED TO INTERNET-CONNECTED SMART PHONES, TABLETS, SET-TOP BOXES AND COMPUTERS; ONLINE ADVERTISING AND MARKETING SERVICES, NAMELY, PROVIDING AN ONLINE ADVERTISING NETWORK THAT SPECIALIZES IN WEB USER TARGETING AND ADVERTISING OPTIMIZATION FOR ONLINE ADVERTISERS AND PUBLISHERS OF VIDEO CONTENT (U.S. CLS. 100, 101 AND 102).

FIRST USE 1-9-2012; IN COMMERCE 1-9-2012.

CLASS 35—(Continued).

4,119,781. VISIBLE MEASURES CORP., BOSTON, MA. SN 85-287,124. FILED P.R. 4-5-2011; AM. S.R. 1-6-2012.

The video ad network of choice for advertisers

THE MARK CONSISTS OF STANDARD CHARACTERS WITHOUT CLAIM TO ANY PARTICULAR FONT, STYLE, SIZE, OR COLOR.

FOR PROVIDING AN ONLINE ADVERTISING NETWORK THAT SPECIALIZES IN WEB USER TARGETING, CUSTOMIZED CONTEXTUAL TARGETING AND ADVERTISING OPTIMIZATION FOR ONLINE ADVERTISERS AND PUBLISHERS; ONLINE ADVERTISING ON COMPUTER COMMUNICATIONS NETWORKS DELIVERED TO INTERNET-CONNECTED SMART PHONES, TABLETS, SET-TOP BOXES AND COMPUTERS, NAMELY, PROVIDING AN INTERNET-BASED ADVERTISING NETWORK THAT CONNECTS ONLINE ADVERTISERS WITH ONLINE PUBLISHERS OF VIDEO CONTENT; ONLINE ADVERTISING AND MARKETING SERVICES, NAMELY, PROVIDING AN ONLINE ADVERTISING NETWORK TO PROMOTE THE GOODS AND SERVICES OF OTHERS BY DISSEMINATING VIDEO CLIPS AND VIDEO CONTENT OVER THE INTERNET AND COMPUTER COMMUNICATIONS NETWORKS DELIVERED TO INTERNET-CONNECTED SMART PHONES, TABLETS, SET-TOP BOXES AND COMPUTERS; ONLINE ADVERTISING AND MARKETING SERVICES, NAMELY, PROVIDING AN ONLINE ADVERTISING NETWORK THAT SPECIALIZES IN WEB USER TARGETING AND ADVERTISING OPTIMIZATION FOR ONLINE ADVERTISERS AND PUBLISHERS OF VIDEO CONTENT (U.S. CLS. 100, 101 AND 102).

FIRST USE 1-6-2012; IN COMMERCE 1-6-2012.

4,119,786. INTELLISTRY INFORMATION SYSTEMS, INC., DBA GEO.TO, IRVINE, CA. SN 85-296,956. FILED P.R. 4-15-2011; AM. S.R. 1-25-2012.

GEOSITE

THE MARK CONSISTS OF STANDARD CHARACTERS WITHOUT CLAIM TO ANY PARTICULAR FONT, STYLE, SIZE, OR COLOR.

FOR ADVERTISEMENT, PROMOTION AND MARKETING SERVICES PROVIDED THROUGH ELECTRONIC MEDIA AND PROVIDING ADVERTISING AND PROMOTIONAL INFORMATION RELATED TO THE PHYSICAL LOCATIONS OF BUSINESSES OVER THE INTERNET OR OTHER COMMUNICATIONS NETWORK; PROVIDING AN ON-LINE COMMERCIAL INFORMATION DIRECTORY ON THE INTERNET THAT INCLUDES THE BUSINESS ADDRESS, PHYSICAL LOCATION OF EVENTS AND BUSINESS ACTIVITY INFORMATION (U.S. CLS. 100, 101 AND 102).

FIRST USE 6-30-2011; IN COMMERCE 6-30-2011.

CLASS 35—(Continued).

4,119,801. AFFINION PUBLISHING, LLC, LAS VEGAS, NV. SN 85-308,779. FILED P.R. 4-29-2011; AM. S.R. 11-16-2011.

WIRELESS PASS

THE MARK CONSISTS OF STANDARD CHARACTERS WITHOUT CLAIM TO ANY PARTICULAR FONT, STYLE, SIZE, OR COLOR.

FOR ADMINISTERING A CONSUMER BENEFIT PROGRAM WHICH ENTITLES MEMBERS TO DISCOUNTS, REBATES AND BONUSES RELATED TO DINING, SHOPPING, ENTERTAINMENT AND WIRELESS PRODUCTS AND SERVICES (U.S. CLS. 100, 101 AND 102).

FIRST USE 6-24-2011; IN COMMERCE 6-24-2011.

4,119,802. EMBRASE BUSINESS CONSULTING INC., WESTMOUNT, QUEBEC, CANADA. SN 85-308,837. FILED P.R. 4-29-2011; AM. S.R. 1-13-2012.

STARTUP FESTIVAL

THE MARK CONSISTS OF STANDARD CHARACTERS WITHOUT CLAIM TO ANY PARTICULAR FONT, STYLE, SIZE, OR COLOR.

PRIORITY CLAIMED UNDER SEC. 44(D) ON CANADA APPLICATION NO. 1523489, FILED 4-13-2011.

FOR ARRANGING AND CONDUCTING EVENTS FOR COMMERCIAL AND PROMOTIONAL PURPOSES IN THE FIELDS OF BUSINESS, TECHNOLOGIES AND EMERGING AND START-UP COMPANIES (U.S. CLS. 100, 101 AND 102).

FIRST USE 1-30-2011; IN COMMERCE 1-30-2011.

4,119,804. DISTILLERY SOLUTIONS, LLC, ARVADA, CO. SN 85-313,630. FILED P.R. 5-5-2011; AM. S.R. 1-31-2012.

DISTILLERY SOLUTIONS

THE MARK CONSISTS OF STANDARD CHARACTERS WITHOUT CLAIM TO ANY PARTICULAR FONT, STYLE, SIZE, OR COLOR.

FOR PROVIDING ONLINE BUSINESS MANAGEMENT SERVICES INCLUDING ACCOUNTING, MARKETING, BUSINESS PROJECT MANAGEMENT, AND BUSINESS DEVELOPMENT (U.S. CLS. 100, 101 AND 102).

FIRST USE 5-1-2010; IN COMMERCE 5-1-2010.

CLASS 35—(Continued).

4,119,805. KANNER, STEVEN, SAVANNAH, GA. SN 85-313,804. FILED P.R. 5-5-2011; AM. S.R. 2-6-2012.

Sport-Swap

THE MARK CONSISTS OF STANDARD CHARACTERS WITHOUT CLAIM TO ANY PARTICULAR FONT, STYLE, SIZE, OR COLOR.

FOR PROVIDING A WEB SITE AT WHICH USERS CAN OFFER GOODS FOR SALE AND BUY GOODS OFFERED BY OTHERS; PROVIDING A WEBSITE FEATURING AN ONLINE MARKETPLACE FOR EXCHANGING GOODS AND SERVICES WITH OTHER USERS (U.S. CLS. 100, 101 AND 102).

FIRST USE 3-26-2011; IN COMMERCE 2-1-2012.

4,119,814. STRIVE COACHING INC, DBA PROFIT THINK TANK, TOPEKA, KS. SN 85-333,008. FILED P.R. 5-28-2011; AM. S.R. 2-1-2012.

Profit Think Tank

THE MARK CONSISTS OF STANDARD CHARACTERS WITHOUT CLAIM TO ANY PARTICULAR FONT, STYLE, SIZE, OR COLOR.

FOR ASSISTANCE, ADVISORY SERVICES AND CONSULTANCY WITH REGARD TO BUSINESS PLANNING, BUSINESS ANALYSIS, BUSINESS MANAGEMENT, AND BUSINESS ORGANIZATION (U.S. CLS. 100, 101 AND 102).

FIRST USE 5-1-2011; IN COMMERCE 5-15-2011.

4,119,815. CA ORGANIZATION, L.L.C., DBA CELEBRITY AUTO GROUP, ORLANDO, FL. SN 85-334,739. FILED P.R. 6-1-2011; AM. S.R. 2-8-2012.

Celebrity Auto

THE MARK CONSISTS OF STANDARD CHARACTERS WITHOUT CLAIM TO ANY PARTICULAR FONT, STYLE, SIZE, OR COLOR.

NO CLAIM IS MADE TO THE EXCLUSIVE RIGHT TO USE "AUTO", APART FROM THE MARK AS SHOWN.

FOR WHOLESALE AND RETAIL DEALERSHIPS IN THE FIELD OF MOTOR VEHICLES AND PARTS (U.S. CLS. 100, 101 AND 102).

FIRST USE 1-1-2011; IN COMMERCE 1-1-2011.

CLASS 35—(Continued).

4,119,822. EBYLINE, INC., SANTA CLARITA, CA. SN 85-350,022. FILED P.R. 6-19-2011; AM. S.R. 2-3-2012.

VIRTUAL NEWSROOM

THE MARK CONSISTS OF STANDARD CHARACTERS WITHOUT CLAIM TO ANY PARTICULAR FONT, STYLE, SIZE, OR COLOR.

NO CLAIM IS MADE TO THE EXCLUSIVE RIGHT TO USE "VIRTUAL", APART FROM THE MARK AS SHOWN.

FOR BUSINESS SERVICES, NAMELY, PROVIDING AN ONLINE NETWORK FOR PUBLISHERS, JOURNALISTS AND WRITERS TO EXCHANGE OR PURCHASE WRITTEN, VISUAL, AUDIO OR VIDEO WORKS BY MEANS OF AN ONLINE MARKETPLACE (U.S. CLS. 100, 101 AND 102).

FIRST USE 6-3-2010; IN COMMERCE 6-3-2010.

4,119,823. ABELA, KEVIN, SAGINAW, MI. SN 85-350,307. FILED P.R. 6-20-2011; AM. S.R. 1-12-2012.

PLANT HEALTH CARE PROGRAMS

THE MARK CONSISTS OF STANDARD CHARACTERS WITHOUT CLAIM TO ANY PARTICULAR FONT, STYLE, SIZE, OR COLOR.

FOR PROJECT MANAGEMENT SERVICES FOR OTHERS FOR BUSINESS PURPOSES IN THE FIELDS OF ARCHITECTURE, INTERIOR DESIGN, URBAN PLANNING DESIGN (U.S. CLS. 100, 101 AND 102).

FIRST USE 10-1-2011; IN COMMERCE 10-1-2011.

4,119,856. M&M GIFT SHOWS, LLC, TOLEDO, OH. SN 85-421,690. FILED P.R. 9-13-2011; AM. S.R. 1-16-2012.

AMERICA'S SOUVENIR SHOW

THE MARK CONSISTS OF STANDARD CHARACTERS WITHOUT CLAIM TO ANY PARTICULAR FONT, STYLE, SIZE, OR COLOR.

OWNER OF U.S. REG. NOS. 3,720,334 AND 3,848,532. NO CLAIM IS MADE TO THE EXCLUSIVE RIGHT TO USE "SHOW", APART FROM THE MARK AS SHOWN.

FOR ARRANGING AND CONDUCTING TRADE SHOWS IN THE FIELD OF GIFTS AND RELATED MERCHANDISE (U.S. CLS. 100, 101 AND 102).

FIRST USE 6-0-2011; IN COMMERCE 6-0-2011.

CLASS 35—(Continued).

4,119,857. MICHAEL J PAULHUS, DBA THE PUZZLE PAGES, LARGO, FL. AND CHERYL A MCKEE, DBA THE PUZZLE PAGES, LARGO, FL. SN 85-424,220. FILED 9-15-2011.



THE COLOR(S) RED, BLUE AND YELLOW IS/ARE CLAIMED AS A FEATURE OF THE MARK.

THE MARK CONSISTS OF A RED BOX WITHIN ARE THE WORDS "THE" IN CAPITALIZED YELLOW LETTERS IN THE TOP LEFT CORNER SMALLER THAN THE OTHER WORDS, "PUZZLE" IN CAPITALIZED BLUE LETTERS IN THE CENTER AND "PAGES" IN YELLOW LOWER CASE LETTERS BELOW "PUZZLE".

FOR NEWSPAPER ADVERTISING (U.S. CLS. 100, 101 AND 102).

FIRST USE 5-11-2011; IN COMMERCE 5-11-2011.

CLASS 35—(Continued).

4,119,864. ALLIANCE FOR EARTH, LIFE, LIBERTY & ADVOCATION, INC., NORTH PORT, FL. SN 85-431,181. FILED P.R. 9-24-2011; AM. S.R. 1-19-2012.

STOPCRUSH.ORG

THE MARK CONSISTS OF STANDARD CHARACTERS WITHOUT CLAIM TO ANY PARTICULAR FONT, STYLE, SIZE, OR COLOR.

FOR PUBLIC ADVOCACY TO PROMOTE AWARENESS OF THE NEED TO STOP ANIMAL CRUSH VIDEOS (U.S. CLS. 100, 101 AND 102).

FIRST USE 12-1-2009; IN COMMERCE 5-1-2010.

4,119,863. PRESS GANEY ASSOCIATES, INC, SOUTH BEND, IN. SN 85-428,854. FILED P.R. 9-22-2011; AM. S.R. 1-26-2012.

4,119,867. BEAT BROKERS GLOBAL LLC, VACAVILLE, CA. SN 85-442,569. FILED P.R. 10-7-2011; AM. S.R. 1-31-2012.

BRAND POSITION ANALYSIS

Beat Brokerz

THE MARK CONSISTS OF STANDARD CHARACTERS WITHOUT CLAIM TO ANY PARTICULAR FONT, STYLE, SIZE, OR COLOR.

NO CLAIM IS MADE TO THE EXCLUSIVE RIGHT TO USE "ANALYSIS", APART FROM THE MARK AS SHOWN.

FOR BUSINESS ANALYSIS AND MANAGEMENT CONSULTING FOR HEALTHCARE PROVIDERS AND RELATED BUSINESSES, ANALYSIS RELATING TO THE UNDERSTANDING OF PUBLIC OPINION; BUSINESS SERVICES, NAMELY, CONDUCTING PATIENT SATISFACTION SURVEYS IN THE HEALTH CARE OR MEDICAL FIELDS AND PROVIDING BUSINESS CONSULTATION FOR THE IMPROVEMENT OF PATIENT SATISFACTION; MONITORING PATIENTS' EXPERIENCE OF CARE ON A REAL-TIME BASIS IN THE FIELD OF HEALTHCARE; PROVIDING STATISTICAL DATA SOLUTIONS FOR THE PURPOSE OF BRAND POSITIONING (U.S. CLS. 100, 101 AND 102).

FIRST USE 7-1-2009; IN COMMERCE 7-1-2009.

THE MARK CONSISTS OF STANDARD CHARACTERS WITHOUT CLAIM TO ANY PARTICULAR FONT, STYLE, SIZE, OR COLOR.

NO CLAIM IS MADE TO THE EXCLUSIVE RIGHT TO USE "BROKERS", APART FROM THE MARK AS SHOWN.

FOR MEDIATION AND CONCLUSION OF COMMERCIAL TRANSACTIONS FOR OTHERS; OPERATING ONLINE MARKETPLACES FOR SELLERS OF GOODS AND/OR SERVICES IN THE FIELD OF MUSIC; PROVIDING A WEBSITE FEATURING INFORMATION AND LINKS RELATING TO THE MUSIC INDUSTRY, NAMELY, PROMOTION, MARKETING AND BUSINESS ADVICE TO MUSICIANS (U.S. CLS. 100, 101 AND 102).

FIRST USE 1-25-2011; IN COMMERCE 3-30-2011.

CLASS 35—(Continued).

4,119,874. MONARCH BEVERAGE CO., INC., INDIANAPOLIS, IN. SN 85-446,200. FILED P.R. 10-13-2011; AM. S.R. 2-6-2012.



OWNER OF U.S. REG. NOS. 3,638,753 AND 3,744,147.
NO CLAIM IS MADE TO THE EXCLUSIVE RIGHT TO USE "WORLD CLASS BEER", APART FROM THE MARK AS SHOWN.

THE MARK CONSISTS OF A SHIELD CONTAINING THE WORDS "WORLD CLASS BEER" AND A SMALLER SHIELD CONTAINING A CIRCULAR DESIGN WITH A HOP CONE AND INTERSECTING LINES IN THE MIDDLE OF THE CIRCULAR DESIGN.

FOR ASSISTING WHOLESALE BEER DISTRIBUTORSHIPS PROMOTE THEIR PRODUCTS AND BUILD CUSTOMER LOYALTY BY PROVIDING CONSUMER EDUCATION ABOUT BEER AND BREWERIES; PROMOTION OF CRAFT BEERS AND THE CRAFT BEER MARKET; PROVIDING CONSUMER PRODUCT INFORMATION IN THE FIELD OF BEER; DISTRIBUTORSHIP IN THE FIELD OF BEER (U.S. CLS. 100, 101 AND 102).
FIRST USE 10-4-2011; IN COMMERCE 10-4-2011.

4,119,877. TEXAS HIGHER EDUCATION COORDINATING BOARD, AUSTIN, TX. SN 85-447,768. FILED P.R. 10-14-2011; AM. S.R. 2-2-2012.

ADVISE TX

THE MARK CONSISTS OF STANDARD CHARACTERS WITHOUT CLAIM TO ANY PARTICULAR FONT, STYLE, SIZE, OR COLOR.

OWNER OF U.S. REG. NOS. 4,029,497, 4,061,110, AND OTHERS.

FOR PROMOTING PUBLIC AWARENESS OF THE BENEFITS OF POSTSECONDARY EDUCATION ADVISERS THROUGHOUT TEXAS (U.S. CLS. 100, 101 AND 102).

FIRST USE 2-3-2011; IN COMMERCE 2-9-2011.

CLASS 35—(Continued).

4,119,878. TEXAS HIGHER EDUCATION COORDINATING BOARD, AUSTIN, TX. SN 85-447,899. FILED P.R. 10-14-2011; AM. S.R. 2-2-2012.



COLLEGE ADVISING CORPS

OWNER OF U.S. REG. NOS. 4,029,497, 4,061,110, AND OTHERS.

THE MARK CONSISTS OF THE WORD "ADVISE" IN STYLIZED FONT BETWEEN TWO HORIZONTAL LINES ALONGSIDE THE STYLIZED LETTERS "TX" DISPLAYED WITHIN A SQUARE ALL ABOVE THE WORDS "COLLEGE ADVISING CORPS".

FOR PROMOTING PUBLIC AWARENESS OF THE BENEFITS OF POSTSECONDARY EDUCATION ADVISERS THROUGHOUT TEXAS (U.S. CLS. 100, 101 AND 102).

FIRST USE 2-3-2011; IN COMMERCE 2-9-2011.

4,119,879. PRATIMA RAWAL, KENSAL GREEN, LONDON, UNITED KINGDOM. SN 85-448,827. FILED P.R. 10-17-2011; AM. S.R. 2-7-2012.

THE NAS EXPERTS

THE MARK CONSISTS OF STANDARD CHARACTERS WITHOUT CLAIM TO ANY PARTICULAR FONT, STYLE, SIZE, OR COLOR.

NO CLAIM IS MADE TO THE EXCLUSIVE RIGHT TO USE "NAS", APART FROM THE MARK AS SHOWN.

FOR ON-LINE RETAIL STORE SERVICES FEATURING NETWORKED DATA STORAGE, ELECTRONIC STORAGE, COMPUTER DATA STORAGE (U.S. CLS. 100, 101 AND 102).

FIRST USE 7-23-2010; IN COMMERCE 7-23-2010.

4,119,885. TEXAS HIGHER EDUCATION COORDINATING BOARD, AUSTIN, TX. SN 85-458,710. FILED P.R. 10-28-2011; AM. S.R. 2-2-2012.



OWNER OF U.S. REG. NOS. 4,029,497, 4,061,110, AND OTHERS.

CLASS 35—(Continued).

THE MARK CONSISTS OF THE WORD "ADVISE" IN STYLIZED FONT BETWEEN TWO HORIZONTAL LINES ALONGSIDE THE STYLIZED LETTERS "TX" DISPLAYED WITHIN A SQUARE.

FOR PROMOTING PUBLIC AWARENESS OF THE BENEFITS OF POSTSECONDARY EDUCATION ADVISERS THROUGHOUT TEXAS (U.S. CLS. 100, 101 AND 102).

FIRST USE 2-3-2011; IN COMMERCE 2-9-2011.

CLASS 36—(Continued).

4,119,755. THE SUSAN G. KOMEN BREAST CANCER FOUNDATION, INC., DALLAS, TX. SN 85-146,074. FILED P.R. 10-6-2010; AM. S.R. 12-21-2011.

KOMEN

THE MARK CONSISTS OF STANDARD CHARACTERS WITHOUT CLAIM TO ANY PARTICULAR FONT, STYLE, SIZE, OR COLOR.

OWNER OF U.S. REG. NOS. 3,309,531, 3,836,812, AND OTHERS.

THE ENGLISH TRANSLATION OF "KOMEN" IN THE MARK IS "TO COME".

FOR CHARITABLE FUNDRAISING SERVICES (U.S. CLS. 100, 101 AND 102).

FIRST USE 12-21-2011; IN COMMERCE 12-21-2011.

4,119,888. PENNWELL CORPORATION, TULSA, OK. SN 85-463,963. FILED P.R. 11-3-2011; AM. S.R. 2-1-2012.

OWNER OF U.S. REG. NO. 3,494,299.
NO CLAIM IS MADE TO THE EXCLUSIVE RIGHT TO USE "SHOW", APART FROM THE MARK AS SHOWN.
FOR ARRANGING AND CONDUCTING BUSINESS CONFERENCES AND BUSINESS EXHIBITIONS IN THE FIELD OF THE LIGHT EMITTING DIODE INDUSTRY (U.S. CLS. 100, 101 AND 102).

FIRST USE 11-2-2011; IN COMMERCE 11-2-2011.

4,119,762. CONTRACT LAND STAFF, LLC, SUGAR LAND, TX. SN 85-171,569. FILED P.R. 11-8-2010; AM. S.R. 1-26-2012.

VIRTUAL RIGHT OF WAY

THE MARK CONSISTS OF STANDARD CHARACTERS WITHOUT CLAIM TO ANY PARTICULAR FONT, STYLE, SIZE, OR COLOR.

OWNER OF U.S. REG. NOS. 3,855,125 AND 3,888,261.

NO CLAIM IS MADE TO THE EXCLUSIVE RIGHT TO USE "RIGHT OF WAY", APART FROM THE MARK AS SHOWN.

FOR RIGHT-OF-WAY ACQUISITION, NAMELY, ACQUISITION OF REAL ESTATE RIGHT-OF-WAY EASEMENTS (U.S. CLS. 100, 101 AND 102).

FIRST USE 1-0-2004; IN COMMERCE 1-0-2004.

CLASS 36—INSURANCE AND FINANCIAL

4,119,745. ALLSTATE INSURANCE COMPANY, NORTH-BROOK, IL. SN 85-046,498. FILED P.R. 5-24-2010; AM. S.R. 1-25-2011.

CLAIM SATISFACTION GUARANTEED

THE MARK CONSISTS OF STANDARD CHARACTERS WITHOUT CLAIM TO ANY PARTICULAR FONT, STYLE, SIZE, OR COLOR.

NO CLAIM IS MADE TO THE EXCLUSIVE RIGHT TO USE "SATISFACTION GUARANTEED", APART FROM THE MARK AS SHOWN.

FOR PROPERTY AND CASUALTY INSURANCE SERVICES, NAMELY, CLAIMS ADMINISTRATION, FOR A SELECT GROUP OF INSURANCE CUSTOMERS (U.S. CLS. 100, 101 AND 102).

FIRST USE 12-31-2010; IN COMMERCE 12-31-2010.

4,119,773. IROQUOIS GROUP INC., OLEAN, NY. SN 85-254,111. FILED P.R. 3-1-2011; AM. S.R. 1-26-2012.

PartnerPlan

THE MARK CONSISTS OF STANDARD CHARACTERS WITHOUT CLAIM TO ANY PARTICULAR FONT, STYLE, SIZE, OR COLOR.

FOR INSURANCE AGENCIES IN THE FIELD OF HOME, BUSINESS AND LIFE INSURANCE (U.S. CLS. 100, 101 AND 102).

FIRST USE 5-28-1998; IN COMMERCE 5-28-1998.

CLASS 36—(Continued).

4,119,779. THE LYMPHATIC MALFORMATION INSTITUTE, BETHESDA, MD. SN 85-286,451. FILED P.R. 4-5-2011; AM. S.R. 2-1-2012.

The Lymphatic Malformation Institute

THE MARK CONSISTS OF STANDARD CHARACTERS WITHOUT CLAIM TO ANY PARTICULAR FONT, STYLE, SIZE, OR COLOR.

NO CLAIM IS MADE TO THE EXCLUSIVE RIGHT TO USE "INSTITUTE", APART FROM THE MARK AS SHOWN.

FOR CHARITABLE SERVICES, NAMELY, FUNDING SCIENTIFIC AND MEDICAL RESEARCH AND STUDIES BY MEDICAL AND RESEARCH PROFESSIONALS THAT WILL ADVANCE THE UNDERSTANDING OF LYMPHATIC MALFORMATION AND THE HUMAN LYMPHATIC SYSTEM AS A WHOLE (U.S. CLS. 100, 101 AND 102).

FIRST USE 12-17-2010; IN COMMERCE 2-9-2011.

4,119,808. CITY NATIONAL BANK, BEVERLY HILLS, CA. SN 85-317,371. FILED P.R. 5-10-2011; AM. S.R. 1-18-2012.

Fast Deposit

THE MARK CONSISTS OF STANDARD CHARACTERS WITHOUT CLAIM TO ANY PARTICULAR FONT, STYLE, SIZE, OR COLOR.

NO CLAIM IS MADE TO THE EXCLUSIVE RIGHT TO USE "DEPOSIT", APART FROM THE MARK AS SHOWN.

FOR BANKING SERVICES (U.S. CLS. 100, 101 AND 102).

FIRST USE 11-21-2011; IN COMMERCE 11-21-2011.

4,119,853. THE CAPITAL GROUP COMPANIES, INC., LOS ANGELES, CA. SN 85-418,825. FILED P.R. 9-9-2011; AM. S.R. 2-14-2012.

Capital Emerging Markets Total Opportunities Fund

THE MARK CONSISTS OF STANDARD CHARACTERS WITHOUT CLAIM TO ANY PARTICULAR FONT, STYLE, SIZE, OR COLOR.

CLASS 36—(Continued).

NO CLAIM IS MADE TO THE EXCLUSIVE RIGHT TO USE "EMERGING MARKETS" AND "FUND", APART FROM THE MARK AS SHOWN.

FOR FINANCIAL SERVICES, NAMELY, FINANCIAL ANALYSIS, EVALUATION AND CONSULTATION; INVESTMENT MANAGEMENT AND ADVICE; MUTUAL FUND INVESTMENT MANAGEMENT AND DISTRIBUTION; ANNUITY SERVICES, NAMELY, INVESTMENT MANAGEMENT AND DISTRIBUTION OF VARIABLE ANNUITIES; FIDUCIARY SERVICES, NAMELY, SERVING AS TRUSTEE FOR DIRECTED AND DISCRETIONARY TRUST ACCOUNTS; ESTATE PLANNING; AND FINANCIAL ADMINISTRATION OF EMPLOYEE BENEFIT, PENSION AND RETIREMENT PLANS IN CONNECTION THEREWITH (U.S. CLS. 100, 101 AND 102).

FIRST USE 8-3-2011; IN COMMERCE 8-3-2011.

4,119,862. PACIFICA WEALTH ADVISORS, INC., MISSION VIEJO, CA. SN 85-428,365. FILED P.R. 9-21-2011; AM. S.R. 1-27-2012.

SUDDEN WEALTH

THE MARK CONSISTS OF STANDARD CHARACTERS WITHOUT CLAIM TO ANY PARTICULAR FONT, STYLE, SIZE, OR COLOR.

NO CLAIM IS MADE TO THE EXCLUSIVE RIGHT TO USE "WEALTH", APART FROM THE MARK AS SHOWN.

FOR FINANCIAL ADVISORY AND CONSULTANCY SERVICES (U.S. CLS. 100, 101 AND 102).

FIRST USE 11-1-2011; IN COMMERCE 11-1-2011.

4,119,875. MEDICARECOMPAREUSA, BELLINGHAM, WA. SN 85-446,416. FILED P.R. 10-13-2011; AM. S.R. 2-2-2012.

MedicareCompareUSA

THE MARK CONSISTS OF STANDARD CHARACTERS WITHOUT CLAIM TO ANY PARTICULAR FONT, STYLE, SIZE, OR COLOR.

FOR INSURANCE INFORMATION AND CONSULTANCY (U.S. CLS. 100, 101 AND 102).

FIRST USE 7-0-2011; IN COMMERCE 9-0-2011.

CLASS 36—(Continued).

4,119,881. VIP FUNDRAISERS, INC., CHARLOTTE, NC. SN 85-449,634. FILED P.R. 10-18-2011; AM. S.R. 2-6-2012.

CLASS 38—(Continued).

4,119,788. CHATURVEDI, DR. ANOOP, SUGAR LAND, TX. SN 85-297,741. FILED P.R. 4-18-2011; AM. S.R. 1-31-2012.

FREE DRINK CARD

THE MARK CONSISTS OF STANDARD CHARACTERS WITHOUT CLAIM TO ANY PARTICULAR FONT, STYLE, SIZE, OR COLOR.

FOR CHARITABLE FUNDRAISING (U.S. CLS. 100, 101 AND 102).

FIRST USE 12-0-2009; IN COMMERCE 12-0-2009.

World Anti-Aging Network

THE MARK CONSISTS OF STANDARD CHARACTERS WITHOUT CLAIM TO ANY PARTICULAR FONT, STYLE, SIZE, OR COLOR.

NO CLAIM IS MADE TO THE EXCLUSIVE RIGHT TO USE "NETWORK", APART FROM THE MARK AS SHOWN. FOR PROVIDING ON-LINE FORUMS FOR TRANSMISSION OF MESSAGES AMONG COMPUTER USERS CONCERNING ANTI-AGING, NUTRITION AND WELLNESS (U.S. CLS. 100, 101 AND 104).

FIRST USE 9-1-2009; IN COMMERCE 9-1-2009.

4,119,887. CITY AND COUNTY OF SAN FRANCISCO, SAN FRANCISCO, CA. SN 85-462,450. FILED P.R. 11-2-2011; AM. S.R. 2-2-2012.

CurrenC

THE MARK CONSISTS OF STANDARD CHARACTERS WITHOUT CLAIM TO ANY PARTICULAR FONT, STYLE, SIZE, OR COLOR.

FOR BANKING AND FINANCING SERVICES (U.S. CLS. 100, 101 AND 102).

FIRST USE 1-1-2011; IN COMMERCE 1-1-2011.

CLASS 39—TRANSPORTATION AND STORAGE

4,119,850. AGARWAL PACKERS & MOVERS LTD., NEW DELHI, INDIA. SN 85-416,094. FILED P.R. 9-6-2011; AM. S.R. 2-2-2012.

CLASS 37—CONSTRUCTION AND REPAIR

4,119,783. EP-CM PROJECT MANAGEMENT USA, LLC, LONG BEACH, CA. SN 85-294,318. FILED 4-13-2011.

Float-Based Prioritization

THE MARK CONSISTS OF STANDARD CHARACTERS WITHOUT CLAIM TO ANY PARTICULAR FONT, STYLE, SIZE, OR COLOR.

FOR CONSTRUCTION, MAINTENANCE, AND CONSTRUCTION PROJECT MANAGEMENT SERVICES IN OIL AND GAS FIELDS (U.S. CLS. 100, 103 AND 106).

FIRST USE 2-11-2009; IN COMMERCE 11-9-2010.



NO CLAIM IS MADE TO THE EXCLUSIVE RIGHT TO USE "PACKERS & MOVERS", APART FROM THE MARK AS SHOWN.

THE MARK CONSISTS OF THE WORD "AGARWAL" IN BOLD LETTERS ABOVE THE WORDS "PACKERS &", ABOVE THE WORD "MOVERS".

CLASS 38—COMMUNICATION

CLASS 39—(Continued).

THE WORDING "AGARWAL" HAS NO MEANING IN A FOREIGN LANGUAGE.

FOR AIR TRANSPORT AND STORAGE OF GOODS; ARRANGING TRAVEL TOURS; COORDINATING TRAVEL ARRANGEMENTS FOR INDIVIDUALS AND FOR GROUPS; DELIVERY AND STORAGE OF GOODS; MOVING AND STORAGE OF GOODS; MOVING VAN TRANSPORT; PACKAGING ARTICLES FOR TRANSPORTATION; PACKING ARTICLES FOR TRANSPORTATION; PICK UP, DELIVERY AND STORAGE OF PERSONAL PROPERTY; STORAGE OF CLOTHING; STORAGE OF GOODS; SUPPLY CHAIN LOGISTICS AND REVERSE LOGISTICS SERVICES, NAMELY, STORAGE, TRANSPORTATION AND DELIVERY OF DOCUMENTS, PACKAGES, RAW MATERIALS, AND OTHER FREIGHT FOR OTHERS BY AIR, RAIL, SHIP OR TRUCK; SUPPLY CHAIN LOGISTICS AND REVERSE LOGISTICS SERVICES, NAMELY, STORAGE, TRANSPORTATION AND DELIVERY OF GOODS FOR OTHERS BY AIR, RAIL, SHIP OR TRUCK; TRANSPORT AND DELIVERY OF GOODS; TRANSPORT AND STORAGE OF GOODS; TRANSPORT BROKERAGE; TRANSPORT OF PERSONS AND GOODS; TRANSPORT OF VALUABLES; TRANSPORT SERVICES, NAMELY, LOCAL, INTERSTATE AND INTERNATIONAL MOVING SERVICES; TRAVEL AGENCY SERVICES, NAMELY, MAKING RESERVATIONS AND BOOKINGS FOR TRANSPORTATION; TRAVEL BOOKING AGENCIES; TRUCK TRANSPORT; WAREHOUSING SERVICES, NAMELY, STORAGE, DISTRIBUTION, PICK-UP, AND PACKING FOR SHIPMENTS OF DOCUMENTS, PACKAGES, RAW MATERIALS, AND OTHER FREIGHT FOR OTHERS (U.S. CLS. 100 AND 105).

FIRST USE 1-4-1991; IN COMMERCE 2-10-2011.

CLASS 41—EDUCATION AND ENTERTAINMENT

4,119,750. PDR NETWORK, LLC, MONTVALE, NJ. SN 85-124,454. FILED P.R. 9-7-2010; AM. S.R. 1-16-2012.

PharmEHR

THE MARK CONSISTS OF STANDARD CHARACTERS WITHOUT CLAIM TO ANY PARTICULAR FONT, STYLE, SIZE, OR COLOR.

FOR EDUCATIONAL SERVICES, NAMELY, CONDUCTING CONFERENCES IN THE FIELD OF ELECTRONIC HEALTH RECORDS AS THEY RELATE TO THE PHARMACEUTICAL INDUSTRY (U.S. CLS. 100, 101 AND 107).

FIRST USE 3-1-2011; IN COMMERCE 3-1-2011.

CLASS 41—(Continued).

4,119,752. AMERICA'S NEWS NETWORK, LAS VEGAS, NV. SN 85-136,577. FILED P.R. 9-23-2010; AM. S.R. 1-23-2012.

AMERICA'S NEWS NETWORK

THE MARK CONSISTS OF STANDARD CHARACTERS WITHOUT CLAIM TO ANY PARTICULAR FONT, STYLE, SIZE, OR COLOR.

NO CLAIM IS MADE TO THE EXCLUSIVE RIGHT TO USE "NEWS NETWORK", APART FROM THE MARK AS SHOWN.

FOR ENTERTAINMENT SERVICES, NAMELY, THE PROVISION OF CONTINUING PROGRAMS FEATURING BREAKING NEWS, OPINION, PRESENTATIONS, INTERVIEWS, AND INDIVIDUAL SERIALIZED NEWS REPORTS DELIVERED BY INTERNET, SATELLITE, HANDHELD DEVICES, AND RADIO (U.S. CLS. 100, 101 AND 107).

FIRST USE 1-20-2012; IN COMMERCE 1-20-2012.

4,119,753. AMERICA'S NEWS NETWORK, LAS VEGAS, NV. SN 85-136,584. FILED P.R. 9-23-2010; AM. S.R. 1-23-2012.

AMERICA'S ENTERTAINMENT NEWS NETWORK

THE MARK CONSISTS OF STANDARD CHARACTERS WITHOUT CLAIM TO ANY PARTICULAR FONT, STYLE, SIZE, OR COLOR.

NO CLAIM IS MADE TO THE EXCLUSIVE RIGHT TO USE "NEWS NETWORK", APART FROM THE MARK AS SHOWN.

FOR ENTERTAINMENT SERVICES, NAMELY, THE PROVISION OF CONTINUING PROGRAMS FEATURING BREAKING NEWS, OPINION, PRESENTATIONS, INTERVIEWS, AND INDIVIDUAL SERIALIZED NEWS REPORTS DELIVERED BY INTERNET, SATELLITE, HANDHELD DEVICES, AND RADIO (U.S. CLS. 100, 101 AND 107).

FIRST USE 1-20-2012; IN COMMERCE 1-20-2012.

4,119,761. TADEVOSYAN, ALEN, DBA PRISON CHANNEL, BURBANK, CA. SN 85-167,473. FILED P.R. 11-2-2010; AM. S.R. 1-14-2012.

Prison channel

THE MARK CONSISTS OF STANDARD CHARACTERS WITHOUT CLAIM TO ANY PARTICULAR FONT, STYLE, SIZE, OR COLOR.

CLASS 41—(Continued).

NO CLAIM IS MADE TO THE EXCLUSIVE RIGHT TO USE "CHANNEL", APART FROM THE MARK AS SHOWN.

FOR ENTERTAINMENT IN THE NATURE OF ONGOING TELEVISION PROGRAMS IN THE FIELD OF PRISON (U.S. CLS. 100, 101 AND 107).

FIRST USE 5-4-2009; IN COMMERCE 5-15-2010.

4,119,789. VANACORE MUSIC PUBLISHING, LLC, SANTA CLARITA, CA. SN 85-300,408. FILED P.R. 4-20-2011; AM. S.R. 2-15-2012.

VANACORE MUSIC

THE MARK CONSISTS OF STANDARD CHARACTERS WITHOUT CLAIM TO ANY PARTICULAR FONT, STYLE, SIZE, OR COLOR.

NO CLAIM IS MADE TO THE EXCLUSIVE RIGHT TO USE "MUSIC", APART FROM THE MARK AS SHOWN.

FOR MUSIC LIBRARY SERVICES; MUSIC PRODUCTION SERVICES; COMPOSITION OF MUSIC FOR OTHERS; DEVELOPMENT, CREATION, PRODUCTION AND RECORDING OF NEW MUSIC PACKAGES, NAMELY, PRODUCTION OF SOUND RECORDINGS FOR USE IN FILM, TELEVISION, OR OTHER MEDIA OUTLETS OR ELECTRONIC COMMUNICATION NETWORKS; PRODUCTION OF SOUND RECORDINGS; RECORDING OF SOUNDS; PROVIDING VOICE OVERS FOR TAPES, RECORDS AND OTHER RECORDED MEDIA FOR ENTERTAINMENT AND EDUCATION PURPOSES; CONSULTATION SERVICES IN THE FIELD OF MUSIC PUBLISHING SERVICES; PROVIDING AN ON-LINE WEBSITE FEATURING LIBRARIES OF MUSICAL COMPOSITION AND MUSIC SOUND RECORDINGS FOR ENTERTAINMENT PURPOSES; PROVIDING INFORMATION ON MUSICAL COMPOSITION AND MUSIC SOUND RECORDINGS VIA ELECTRONIC AND OTHER MEANS; ON-LINE LIBRARY SERVICES, NAMELY, PROVIDING ELECTRONIC LIBRARY SERVICES WHICH FEATURE MUSIC VIA AN ON-LINE COMPUTER NETWORK; MUSIC PUBLISHING SERVICES; ENTERTAINMENT SERVICES, NAMELY, PROVIDING NONDOWNLOADABLE PRERECORDED MUSIC, INFORMATION IN THE FIELD OF MUSIC, AND COMMENTARY AND ARTICLES ABOUT MUSIC, ALL ON-LINE VIA A GLOBAL COMPUTER NETWORK; PRODUCTION OF SOUND RECORDINGS FEATURING MUSIC; MULTIMEDIA ENTERTAINMENT SERVICES IN THE NATURE OF RECORDING, PRODUCTION, AND POSTPRODUCTION SERVICES IN THE FIELDS OF MUSIC, VIDEO AND FILMS (U.S. CLS. 100, 101 AND 107).

FIRST USE 12-9-2009; IN COMMERCE 12-9-2009.

CLASS 41—(Continued).

4,119,803. KELLY, KYLE, FAIRLESS HILLS, PA. SN 85-311,924. FILED P.R. 5-4-2011; AM. S.R. 2-2-2012.

Foam N' Glow

THE MARK CONSISTS OF STANDARD CHARACTERS WITHOUT CLAIM TO ANY PARTICULAR FONT, STYLE, SIZE, OR COLOR.

FOR ARRANGING, CONDUCTING, AND HOSTING SOCIAL EVENTS, NAMELY, DANCE PARTIES, GLOW IN THE DARK FOAM PARTIES, BLACKLIGHT FOAM PARTIES, FOR SOCIAL ENTERTAINMENT (U.S. CLS. 100, 101 AND 107).

FIRST USE 4-1-2011; IN COMMERCE 4-16-2011.

4,119,807. ZUFFA, LLC, LAS VEGAS, NV. SN 85-317,317. FILED P.R. 5-10-2011; AM. S.R. 2-15-2012.

FIGHT LIBRARY

THE MARK CONSISTS OF STANDARD CHARACTERS WITHOUT CLAIM TO ANY PARTICULAR FONT, STYLE, SIZE, OR COLOR.

FOR PROVIDING NON-DOWNLOADABLE AUDIO AND VIDEO RECORDINGS FEATURING SPORTS AND ENTERTAINMENT VIA GLOBAL COMMUNICATION NETWORK AND VIDEO-ON-DEMAND SERVICE; PROVIDING A WEBSITE PORTAL IN FIELDS OF SPORTS AND ENTERTAINMENT; PROVIDING AN ONLINE SEARCHABLE DATABASE FEATURING SPORTS AND ENTERTAINMENT (U.S. CLS. 100, 101 AND 107).

FIRST USE 2-0-2011; IN COMMERCE 2-0-2011.

4,119,810. JOHN AUGUST MEDIA, LLC, BAINBRIDGE ISLAND, WA. SN 85-321,294. FILED P.R. 5-15-2011; AM. S.R. 1-30-2012.

Concept Car

THE MARK CONSISTS OF STANDARD CHARACTERS WITHOUT CLAIM TO ANY PARTICULAR FONT, STYLE, SIZE, OR COLOR.

FOR PROVIDING ON-LINE MAGAZINES IN THE FIELD OF AUTOMOTIVE TECHNOLOGY (U.S. CLS. 100, 101 AND 107).

FIRST USE 8-1-2011; IN COMMERCE 11-21-2011.

CLASS 41—(Continued).

4,119,816. THE WASHINGTON TIMES LLC, WASHINGTON, DC. SN 85-335,229. FILED P.R. 6-1-2011; AM. S.R. 1-27-2012.

AMERICA'S MORNING NEWS

THE MARK CONSISTS OF STANDARD CHARACTERS WITHOUT CLAIM TO ANY PARTICULAR FONT, STYLE, SIZE, OR COLOR.

NO CLAIM IS MADE TO THE EXCLUSIVE RIGHT TO USE "NEWS", APART FROM THE MARK AS SHOWN.

FOR ENTERTAINMENT, NAMELY, A CONTINUING NEWS SHOW BROADCAST OVER RADIO (U.S. CLS. 100, 101 AND 107).

FIRST USE 6-15-2009; IN COMMERCE 6-15-2009.

4,119,821. AMERICAN SOCIETY OF NEPHROLOGY, WASHINGTON, DC. SN 85-347,055. FILED P.R. 6-15-2011; AM. S.R. 2-3-2012.

Kidney Week

THE MARK CONSISTS OF STANDARD CHARACTERS WITHOUT CLAIM TO ANY PARTICULAR FONT, STYLE, SIZE, OR COLOR.

FOR EDUCATIONAL SERVICES, NAMELY, CONDUCTING SEMINARS, EDUCATIONAL COURSES AND ANNUAL MEETINGS IN THE FIELD OF NEPHROLOGY AND DISTRIBUTION OF COURSE AND EDUCATIONAL MATERIALS IN CONNECTION THEREWITH (U.S. CLS. 100, 101 AND 107).

FIRST USE 6-1-2011; IN COMMERCE 6-1-2011.

4,119,824. SECURITIES AND COMMERCE INSTITUTE, LLC, MIAMI, FL. SN 85-351,237. FILED P.R. 6-21-2011; AM. S.R. 2-1-2012.

**INTERNATIONAL HOSPITALITY
AND TOURISM INSTITUTE**

THE MARK CONSISTS OF STANDARD CHARACTERS WITHOUT CLAIM TO ANY PARTICULAR FONT, STYLE, SIZE, OR COLOR.

CLASS 41—(Continued).

NO CLAIM IS MADE TO THE EXCLUSIVE RIGHT TO USE "INSTITUTE", APART FROM THE MARK AS SHOWN.

FOR EDUCATIONAL AND ENTERTAINMENT SERVICES, NAMELY, ARRANGING AND CONDUCTING COURSES, ONLINE COURSES, SEMINARS, WEBINARS AND WORKSHOPS IN THE FIELD OF HOSPITALITY, HOTEL, RESTAURANT, SPA, CASINO AND GAMING, AND LODGING OPERATIONS; EDUCATIONAL SERVICES, NAMELY, PREPARING, ADMINISTERING AND SCORING OF EDUCATIONAL EXAMINATIONS IN THE FIELD OF HOSPITALITY, HOTEL, CRUISE, TOURISM, RESORTS, RESTAURANT, SPA, CASINO AND GAMING, AND LODGING OPERATIONS FOR THE PURPOSES OF CERTIFICATION AND LICENSURE (U.S. CLS. 100, 101 AND 107).

FIRST USE 3-12-2011; IN COMMERCE 5-15-2011.

4,119,827. USAA LLC, DBA INTERNATIONAL INSTITUTE OF EVENT MANAGEMENT, LOS GATOS, CA. SN 85-360,219. FILED P.R. 6-30-2011; AM. S.R. 1-6-2012.

**International Institute of
Event Management**

THE MARK CONSISTS OF STANDARD CHARACTERS WITHOUT CLAIM TO ANY PARTICULAR FONT, STYLE, SIZE, OR COLOR.

NO CLAIM IS MADE TO THE EXCLUSIVE RIGHT TO USE "INSTITUTE", APART FROM THE MARK AS SHOWN.

FOR EDUCATION SERVICES, NAMELY, PROVIDING LIVE AND ON-LINE CLASSES, SEMINARS, WORKSHOPS, AND CERTIFICATIONS IN THE FIELD OF EVENT MANAGEMENT, EVENT PLANNING AND WEDDING PLANNING (U.S. CLS. 100, 101 AND 107).

FIRST USE 6-24-2011; IN COMMERCE 6-24-2011.

4,119,829. TWENTIETH CENTURY FOX FILM CORPORATION, LOS ANGELES, CA. SN 85-364,704. FILED P.R. 7-6-2011; AM. S.R. 2-1-2012.

GOALS ON SUNDAY

THE MARK CONSISTS OF STANDARD CHARACTERS WITHOUT CLAIM TO ANY PARTICULAR FONT, STYLE, SIZE, OR COLOR.

FOR ENTERTAINMENT SERVICES IN THE NATURE OF A TELEVISION SERIES FEATURING SPORTS; ENTERTAINMENT SERVICES IN THE NATURE OF NON-DOWNLOADABLE VIDEOS FEATURING TELEVISION SHOWS TRANSMITTED VIA THE INTERNET AND WIRELESS COMMUNICATION NETWORKS (U.S. CLS. 100, 101 AND 107).

FIRST USE 8-14-2011; IN COMMERCE 8-14-2011.

CLASS 41—(Continued).

4,119,868. ABERJE ASSOCIAÇÃO BRASILEIRA DE COMUNICAÇÃO EMPRESARIAL, SÃO PAULO, BRAZIL. SN 85-442,991. FILED P.R. 10-10-2011; AM. S.R. 2-3-2012.

Brazilian Corporate Communications Day

THE MARK CONSISTS OF STANDARD CHARACTERS WITHOUT CLAIM TO ANY PARTICULAR FONT, STYLE, SIZE, OR COLOR.

FOR ARRANGING AND CONDUCTING EDUCATIONAL CONFERENCES; ARRANGING OF SEMINARS; ORGANIZATION OF EVENTS FOR CULTURAL PURPOSES (U.S. CLS. 100, 101 AND 107).
FIRST USE 4-7-2010; IN COMMERCE 4-7-2010.

4,119,883. TEXAS HIGHER EDUCATION COORDINATING BOARD, AUSTIN, TX. SN 85-457,918. FILED P.R. 10-27-2011; AM. S.R. 2-2-2012.

ADVISE TX

THE MARK CONSISTS OF STANDARD CHARACTERS WITHOUT CLAIM TO ANY PARTICULAR FONT, STYLE, SIZE, OR COLOR.

OWNER OF U.S. REG. NOS. 4,061,109, 4,064,330, AND OTHERS.
FOR EDUCATION SERVICES, NAMELY, PROVIDING NEAR-PEER ADVISORY INFORMATION ABOUT POST-SECONDARY EDUCATION THROUGHOUT TEXAS (U.S. CLS. 100, 101 AND 107).
FIRST USE 2-3-2011; IN COMMERCE 2-9-2011.

4,119,884. TEXAS HIGHER EDUCATION COORDINATING BOARD, AUSTIN, TX. SN 85-457,981. FILED P.R. 10-27-2011; AM. S.R. 2-2-2012.



COLLEGE ADVISING CORPS

OWNER OF U.S. REG. NOS. 4,061,109, 4,064,330, AND OTHERS.

CLASS 41—(Continued).

THE MARK CONSISTS OF THE WORD "ADVISE" IN STYLIZED FONT BETWEEN TWO HORIZONTAL LINES ALONGSIDE THE STYLIZED LETTERS "TX" DISPLAYED WITHIN A SQUARE ALL ABOVE THE WORDS "COLLEGE ADVISING CORPS".

FOR EDUCATION SERVICES, NAMELY, PROVIDING NEAR-PEER ADVISORY INFORMATION ABOUT POST-SECONDARY EDUCATION THROUGHOUT TEXAS (U.S. CLS. 100, 101 AND 107).
FIRST USE 2-3-2011; IN COMMERCE 2-9-2011.

4,119,886. TEXAS HIGHER EDUCATION COORDINATING BOARD, AUSTIN, TX. SN 85-458,748. FILED P.R. 10-28-2011; AM. S.R. 2-2-2012.



OWNER OF U.S. REG. NOS. 4,061,109, 4,064,330, AND OTHERS.

THE MARK CONSISTS OF THE WORD "ADVISE" IN STYLIZED FONT BETWEEN TWO HORIZONTAL LINES ALONGSIDE THE STYLIZED LETTERS "TX" DISPLAYED WITHIN A SQUARE.

FOR EDUCATION SERVICES, NAMELY, PROVIDING NEAR-PEER ADVISORY INFORMATION ABOUT POST-SECONDARY EDUCATION THROUGHOUT TEXAS (U.S. CLS. 100, 101 AND 107).
FIRST USE 2-3-2011; IN COMMERCE 2-9-2011.

CLASS 42—SCIENTIFIC AND COMPUTER SERVICES

CLASS 42—(Continued).

4,119,739. IDENTITY WORKS, INC., WEST SALEM, WI. SN 77-926,115. FILED P.R. 2-2-2010; AM. S.R. 2-9-2012.

BRAND DRIVEN TECHNOLOGY
SOLUTIONS

THE MARK CONSISTS OF STANDARD CHARACTERS WITHOUT CLAIM TO ANY PARTICULAR FONT, STYLE, SIZE, OR COLOR.

FOR DESIGN, DEVELOP, CREATE, MAINTAIN AND SUPPORT INTERNET AND INTRANET WEBSITES FOR OTHERS; DESIGN, DEVELOP, CREATE AND MAINTAIN NON-DOWNLOADABLE CUSTOMIZED WEB-BASED SOFTWARE FOR USE IN PURCHASING PROMOTIONAL PRODUCTS, GIFT PRODUCTS, BRANDED APPAREL, PRINTED PRODUCTS, POINT OF PURCHASE PRODUCTS, SIGNS, AND MARKETING MATERIALS; PROVIDE TECHNICAL SUPPORT, NAMELY, TROUBLESHOOTING, TECHNICAL CONSULTATION AND MONITORING OF THE FOREGOING WEB-BASED SOFTWARE; PROVIDING NON-DOWNLOADABLE WEB-BASED SOFTWARE APPLICATIONS FOR OTHERS FOR THE PURPOSE OF ENHANCING THE BRAND NAMES OF OTHERS, NAMELY, FOR USE IN EVENT REGISTRATION, REWARD PROGRAMS AND THE ORGANIZATION, STREAMLINING, PURCHASING, WAREHOUSING, ORDER FULFILLMENT AND DISTRIBUTION OF PROMOTIONAL PRODUCTS, GIFT PRODUCTS, BRANDED APPAREL, PRINTED PRODUCTS, POINT OF PURCHASE PRODUCTS, SIGNS, AND MARKETING MATERIALS (U.S. CLS. 100 AND 101).

FIRST USE 9-16-2008; IN COMMERCE 9-25-2008.

4,119,760. AXIOMA OECONOMIA, LLC, BELLEAIR, FL. SN 85-162,488. FILED 10-27-2010.

BUSINESS VIABILITY INDEX

THE MARK CONSISTS OF STANDARD CHARACTERS WITHOUT CLAIM TO ANY PARTICULAR FONT, STYLE, SIZE, OR COLOR.

NO CLAIM IS MADE TO THE EXCLUSIVE RIGHT TO USE "INDEX", APART FROM THE MARK AS SHOWN.

FOR PROVIDING, ONLINE NON-DOWNLOADABLE COMPUTER SOFTWARE FOR USE IN ANALYZING, CALCULATING, AND ILLUSTRATING FINANCIAL METRICS AND INDICATORS FOR USE IN EVALUATION, GROWTH, EXPANSION, AND DEVELOPMENT OF A BUSINESS, IN THE FIELDS OF FINANCE, FINANCIAL PLANNING, BUSINESS CONSULTING, PRACTICE MANAGEMENT, AND INFORMATIONAL SERVICES (U.S. CLS. 100 AND 101).

FIRST USE 9-1-2010; IN COMMERCE 9-1-2010.

CLASS 42—(Continued).

4,119,784. THE CADENCE GROUP, INC., ATLANTA, GA. SN 85-295,145. FILED P.R. 4-14-2011; AM. S.R. 1-31-2012.

ePurge

THE MARK CONSISTS OF STANDARD CHARACTERS WITHOUT CLAIM TO ANY PARTICULAR FONT, STYLE, SIZE, OR COLOR.

FOR SOFTWARE AS A SERVICE (SAAS) SERVICES FEATURING SOFTWARE FOR USE IN CONDUCTING COMPLIANCE AUDITS FOR ELECTRONICALLY STORED INFORMATION, LOCATING ELECTRONICALLY STORED INFORMATION, AND DOCUMENTING THE DELETION AND MIGRATION OF ELECTRONIC DOCUMENTS AND INFORMATION (U.S. CLS. 100 AND 101).

FIRST USE 10-17-2011; IN COMMERCE 11-1-2011.

4,119,841. EADOPT, LLC, DAVIDSON, NC. SN 85-404,874. FILED P.R. 8-23-2011; AM. S.R. 1-10-2012.

EADOPT

THE MARK CONSISTS OF STANDARD CHARACTERS WITHOUT CLAIM TO ANY PARTICULAR FONT, STYLE, SIZE, OR COLOR.

FOR COMPUTER SOFTWARE SERVICES, NAMELY, PROVIDING A WEB-BASED SYSTEM AND ONLINE PORTAL FEATURING ONLINE NON-DOWNLOADABLE SOFTWARE THAT ENABLES REGISTERED ADOPTION AGENCIES TO MANAGE ADOPTION PROCESS AND SHARE PROCESS, CHECKLISTS AND DOCUMENTS WITH REGISTERED CLIENTS (U.S. CLS. 100 AND 101).

FIRST USE 5-11-2010; IN COMMERCE 9-9-2010.

4,119,860. KARLEN KLEINKOPF, DBA WHAT TO WEAR GUIDES, RIVER FOREST, IL. SN 85-425,487. FILED P.R. 9-18-2011; AM. S.R. 2-6-2012.

What to Wear Guides

THE MARK CONSISTS OF STANDARD CHARACTERS WITHOUT CLAIM TO ANY PARTICULAR FONT, STYLE, SIZE, OR COLOR.

CLASS 42—(Continued).

NO CLAIM IS MADE TO THE EXCLUSIVE RIGHT TO USE "WHAT TO WEAR", APART FROM THE MARK AS SHOWN.

FOR GRAPHIC DESIGN SERVICES FOR CREATING MARKETING MATERIALS FOR PHOTOGRAPHERS (U.S. CLS. 100 AND 101).

FIRST USE 2-10-2010; IN COMMERCE 2-10-2010.

CLASS 43—(Continued).

4,119,851. BROOKLYN ON NORMAN INC., NEW YORK, NY. SN 85-416,346. FILED P.R. 9-7-2011; AM. S.R. 2-6-2012.

BROOKLYN MAC

THE MARK CONSISTS OF STANDARD CHARACTERS WITHOUT CLAIM TO ANY PARTICULAR FONT, STYLE, SIZE, OR COLOR.

FOR RESTAURANT SERVICES (U.S. CLS. 100 AND 101).

FIRST USE 8-15-2010; IN COMMERCE 11-1-2010.

CLASS 43—HOTEL AND RESTAURANT SERVICES

4,119,811. AL AND DR, INC., ABILENE, TX. SN 85-321,870. FILED P.R. 5-16-2011; AM. S.R. 2-3-2012.

LOW RATES HIGH VALUE

THE MARK CONSISTS OF STANDARD CHARACTERS WITHOUT CLAIM TO ANY PARTICULAR FONT, STYLE, SIZE, OR COLOR.

FOR HOTEL SERVICES (U.S. CLS. 100 AND 101).

FIRST USE 1-0-2010; IN COMMERCE 1-0-2010.



THE COLOR(S) BROWN AND RED IS/ARE CLAIMED AS A FEATURE OF THE MARK.

THE MARK CONSISTS OF THE STYLIZED IMAGE OF THE TERM "BROOKLYN" IN BROWN LOWERCASE LETTERS ABOVE THE TERM "MAC" IN RED LOWERCASE LETTERS.

FOR RESTAURANT SERVICES (U.S. CLS. 100 AND 101).

FIRST USE 8-15-2010; IN COMMERCE 11-1-2010.

4,119,828. CUSTOM HOTEL, LLC, SAN FRANCISCO, CA. SN 85-360,433. FILED P.R. 6-30-2011; AM. S.R. 1-31-2012.

CUSTOM HOTEL

THE MARK CONSISTS OF STANDARD CHARACTERS WITHOUT CLAIM TO ANY PARTICULAR FONT, STYLE, SIZE, OR COLOR.

NO CLAIM IS MADE TO THE EXCLUSIVE RIGHT TO USE "HOTEL", APART FROM THE MARK AS SHOWN.

FOR HOTEL, RESTAURANT AND BAR SERVICES (U.S. CLS. 100 AND 101).

FIRST USE 11-0-2007; IN COMMERCE 11-0-2007.

4,119,861. SBH, LLC, MEMPHIS, TN. SN 85-426,419. FILED P.R. 9-19-2011; AM. S.R. 2-2-2012.

MCEWEN'S

THE MARK CONSISTS OF STANDARD CHARACTERS WITHOUT CLAIM TO ANY PARTICULAR FONT, STYLE, SIZE, OR COLOR.

FOR RESTAURANT SERVICES (U.S. CLS. 100 AND 101).

FIRST USE 7-0-2008; IN COMMERCE 7-0-2008.

CLASS 44—MEDICAL, BEAUTY AND AGRICULTURAL SERVICES

4,119,838. USA MOBILE DRUG TESTING, LLC, TAMPA, FL. SN 85-399,817. FILED P.R. 8-17-2011; AM. S.R. 1-18-2012.

USA MOBILE DRUG TESTING

THE MARK CONSISTS OF STANDARD CHARACTERS WITHOUT CLAIM TO ANY PARTICULAR FONT, STYLE, SIZE, OR COLOR.

OWNER OF U.S. REG. NO. 3,865,689. NO CLAIM IS MADE TO THE EXCLUSIVE RIGHT TO USE "MOBILE DRUG TESTING", APART FROM THE MARK AS SHOWN.

FOR DRUG USE TESTING SERVICES (U.S. CLS. 100 AND 101). FIRST USE 12-31-2008; IN COMMERCE 12-31-2008.

4,119,844. PLAMONDON, LINDA A., DBA AWAKE HYPNOSIS, HAVERHILL, MA. SN 85-407,408. FILED P.R. 8-25-2011; AM. S.R. 12-31-2011.

AWAKE HYPNOSIS

THE MARK CONSISTS OF STANDARD CHARACTERS WITHOUT CLAIM TO ANY PARTICULAR FONT, STYLE, SIZE, OR COLOR.

NO CLAIM IS MADE TO THE EXCLUSIVE RIGHT TO USE "HYPNOSIS", APART FROM THE MARK AS SHOWN. FOR HYPNOSIS SERVICES (U.S. CLS. 100 AND 101). FIRST USE 8-11-2011; IN COMMERCE 8-24-2011.

4,119,849. GCS DISTRIBUTION AND LICENSING, LLC, SUWANEE, GA. SN 85-413,009. FILED P.R. 9-1-2011; AM. S.R. 2-7-2012.

GROUNDCOVER SOLUTIONS

THE MARK CONSISTS OF STANDARD CHARACTERS WITHOUT CLAIM TO ANY PARTICULAR FONT, STYLE, SIZE, OR COLOR.

FOR LANDSCAPING SERVICES, NAMELY, APPLICATION OF TOPICAL COLORANT AND PRESERVATIVE TO PINE STRAW AND MULCH (U.S. CLS. 100 AND 101). FIRST USE 8-2-2006; IN COMMERCE 8-2-2006.

CLASS 44—(Continued).

4,119,855. ARROW INTERNATIONAL INVESTMENT CORP., WILMINGTON, DE. SN 85-420,218. FILED P.R. 9-12-2011; AM. S.R. 2-3-2012.

VESSEL HEALTH AND PRESERVATION

THE MARK CONSISTS OF STANDARD CHARACTERS WITHOUT CLAIM TO ANY PARTICULAR FONT, STYLE, SIZE, OR COLOR.

FOR PROVIDING EDUCATIONAL INFORMATION IN THE FIELD OF MEDICAL AND SURGICAL PROCEDURES (U.S. CLS. 100 AND 101). FIRST USE 1-0-2009; IN COMMERCE 1-0-2009.

4,119,859. EYE CONSULTANTS OF TEXAS, P.A., GRAPEVINE, TX. SN 85-424,495. FILED P.R. 9-16-2011; AM. S.R. 2-1-2012.

DRY EYE INSTITUTE OF NORTH TEXAS

THE MARK CONSISTS OF STANDARD CHARACTERS WITHOUT CLAIM TO ANY PARTICULAR FONT, STYLE, SIZE, OR COLOR.

NO CLAIM IS MADE TO THE EXCLUSIVE RIGHT TO USE "DRY EYE INSTITUTE", APART FROM THE MARK AS SHOWN.

FOR PROFESSIONALS SPECIALIZING IN THE DIAGNOSIS AND TREATMENT OF DRY EYES (U.S. CLS. 100 AND 101). FIRST USE 9-14-2011; IN COMMERCE 9-14-2011.

4,119,866. IMMEDIATE PETCARE, PLLC, LOUISVILLE, KY. SN 85-433,258. FILED P.R. 9-27-2011; AM. S.R. 2-8-2012.

IMMEDIATE PET CARE

THE MARK CONSISTS OF STANDARD CHARACTERS WITHOUT CLAIM TO ANY PARTICULAR FONT, STYLE, SIZE, OR COLOR.

NO CLAIM IS MADE TO THE EXCLUSIVE RIGHT TO USE "PET CARE", APART FROM THE MARK AS SHOWN. FOR VETERINARY CLINIC SERVICES (U.S. CLS. 100 AND 101).

FIRST USE 7-15-2011; IN COMMERCE 8-10-2011.

PRIOR UNITED STATES CLASSIFICATION

APPLICATION IN ONE CLASS

CERTIFICATION MARKS

CLASS A—GOODS

4,119,766. TRUE SOURCE HONEY LLC, AKA TRUE SOURCE, WASHINGTON, DC. SN 85-202,995. FILED P.R. 12-21-2010; AM. S.R. 1-31-2012.

NO CLAIM IS MADE TO THE EXCLUSIVE RIGHT TO USE "CERTIFIED", APART FROM THE MARK AS SHOWN.

THE CERTIFICATION MARK AS USED OR INTENDED TO BE USED BY PERSONS AUTHORIZED BY THE CERTIFIER, CERTIFIES OR IS INTENDED TO CERTIFY THAT THE HONEY PRODUCT HAS BEEN SUBJECT TO A RIGOROUS TRACING, TESTING AND VERIFICATION PROGRAM DESIGNED TO ENSURE THAT THE PRODUCT HAS BEEN LEGALLY IMPORTED INTO THE UNITED STATES.

FOR HONEY (U.S. CL. A).

FIRST USE 12-9-2011; IN COMMERCE 12-9-2011.

True Source Certified

THE MARK CONSISTS OF STANDARD CHARACTERS WITHOUT CLAIM TO ANY PARTICULAR FONT, STYLE, SIZE, OR COLOR.

* * * * *

TRADEMARK REGISTRATIONS RENEWED

The designation "U.S. Cl." appearing in this section refers to the U.S. class in effect prior to Sep. 1, 1973 rather than the international class which applies to applications filed on or after that date. For adoption of international classification see notice in the OFFICIAL GAZETTE of Jun. 26, 1973 (911 O.G. TM 210).

85,150.	LISTERINE STANDARD CHARACTER MARK. U.S. CL. 18. (INT. CL. 5). REG. 1-30-1912.	726,216.	YANMAR AND DESIGN. U.S. CL. 23. (INT. CL. 7). REG. 1-9-1962.
151,272.	808. U.S. CL. 22. (INT. CL. 16). REG. 1-24-1922.	726,316.	FANTASY. U.S. CL. 46. (INT. CLS. 1, 5, 29, 30, 31 AND 32). REG. 1-9-1962.
152,550.	OH HENRY!. U.S. CL. 46. (INT. CL. 30). REG. 2-28-1922.	726,844.	PIONEER (STYLIZED). U.S. CL. 1. (INT. CL. 31). REG. 1-30-1962.
290,958.	TRUSEW. U.S. CL. 43. (INT. CL. 23). REG. 1-19-1932.	726,883.	THERMO-FORGED. U.S. CL. 13. (INT. CL. 6). REG. 1-30-1962.
291,502.	SPUR. U.S. CL. 15. (INT. CL. 4). REG. 2-9-1932.	726,940.	NEVADA. U.S. CL. 22. (INT. CL. 28). REG. 1-30-1962.
294,808.	DAG (STYLIZED). U.S. CL. 6. (INT. CL. 1). REG. 6-7-1932.	727,232.	ELGIN SPORTSMAN. U.S. CL. 27. (INT. CL. 14). REG. 2-6-1962.
296,115.	XXXX PATENT (STYLIZED). U.S. CL. 46. (INT. CL. 30). REG. 7-26-1932.	727,282.	JUSTI. U.S. CL. 44. (INT. CLS. 5, 8, 10 AND 12). REG. 2-6-1962.
390,181.	SUNBEAM (STYLIZED). U.S. CL. 21. (INT. CLS. 7, 9, 11, 12 AND 15). REG. 9-9-1941.	727,756.	HASPEL. U.S. CL. 39. (INT. CL. 25). REG. 2-20-1962.
392,752.	## DOUBLE SHARP AND DESIGN. U.S. CL. 23. (INT. CL. 8). REG. 1-13-1942.	728,894.	DAIRY QUEEN. U.S. CL. 46. (INT. CL. 30). REG. 3-20-1962.
394,221.	NIDO (STYLIZED). U.S. CL. 46. (INT. CL. 29). REG. 3-24-1942.	731,961.	OUR DAILY BREAD. U.S. CL. 107. (INT. CL. 41). REG. 5-22-1962.
394,989.	MULTIZYME. U.S. CL. 6. (INT. CL. 1). REG. 5-5-1942.	731,963.	BK AND DESIGN. U.S. CL. 200. REG. 5-22-1962.
399,245.	DRANO (STYLIZED). U.S. CL. 6. (INT. CL. 1). REG. 12-22-1942.	734,084.	GROTE (STYLIZED). U.S. CL. 21. (INT. CL. 11). REG. 7-10-1962.
545,060.	FERROXCUBE. U.S. CL. 21. (INT. CL. 9). REG. 7-17-1951.	734,333.	PHI BETA KAPPA. U.S. CL. 200. REG. 7-10-1962.
546,426.	PINKERTON DETECTIVE AND DESIGN. U.S. CL. 100. (INT. CL. 42). REG. 8-7-1951.	741,715.	MAGIC. U.S. CL. 51. (INT. CL. 3). REG. 12-4-1962.
549,127.	WHITE ROSE (STYLIZED). U.S. CL. 46. (INT. CLS. 1, 5, 29, 30, 31 AND 32). REG. 10-9-1951.	912,283.	VACU-FLUSH. U.S. CL. 13. (INT. CL. 11). REG. 6-8-1971.
551,076.	VICKERS (STYLIZED). U.S. CL. 13. (INT. CL. 7). REG. 11-20-1951.	922,218.	MICRONOR. U.S. CL. 18. (INT. CL. 5). REG. 10-19-1971.
552,435.	VARIETY (STYLIZED). U.S. CL. 46. (INT. CL. 30). REG. 12-25-1951.	923,583.	ESTANDON STANDARD CHARACTER MARK. U.S. CL. 47. (INT. CL. 33). REG. 11-9-1971.
552,491.	TALLY DENOMINATOR AND DESIGN. U.S. CL. 26. (INT. CL. 9). REG. 12-25-1951.	925,771.	CATERWARE. U.S. CL. 13. (INT. CL. 21). REG. 12-21-1971.
552,557.	EGYPTIAN HENNA AND DESIGN. U.S. CL. 51. (INT. CL. 3). REG. 12-25-1951.	926,056.	FOAMSEAL. U.S. CL. 1. (INT. CL. 17). REG. 12-28-1971.
552,776.	LUG-ALL (STYLIZED). U.S. CL. 23. (INT. CL. 7). REG. 1-1-1952.	926,062.	NORMOUNT. U.S. CL. 5. (INT. CL. 17). REG. 12-28-1971.
552,831.	PLAYER'S. U.S. CL. 17. (INT. CL. 34). REG. 1-1-1952.	926,512.	LA FLOR. U.S. CL. 46. (INT. CL. 30). REG. 1-4-1972.
552,840.	SONOCO (STYLIZED). U.S. CL. 2. (INT. CL. 16). REG. 1-1-1952.	926,516.	PIZZA HUT. U.S. CL. 46. (INT. CL. 29). REG. 1-4-1972.
555,028.	MOTHER GOOSE. U.S. CL. 39. (INT. CL. 25). REG. 2-19-1952.	926,589.	CA (STYLIZED). U.S. CL. 200. REG. 1-4-1972.
555,056.	ACME. U.S. CL. 39. (INT. CL. 25). REG. 2-19-1952.	926,713.	HEET. U.S. CL. 18. (INT. CL. 5). REG. 1-11-1972.
555,093.	PROTO (STYLIZED). U.S. CL. 26. (INT. CL. 9). REG. 2-19-1952.	926,866.	MUSSER. U.S. CL. 36. (INT. CLS. 9 AND 15). REG. 1-11-1972.
555,220.	PENN (STYLIZED). U.S. CL. 21. (INT. CL. 9). REG. 2-26-1952.	926,962.	WILLIAMSBURG (STYLIZED). U.S. CL. 46. (INT. CLS. 1, 5, 29, 30, 31 AND 32). REG. 1-11-1972.
555,462.	CONBRACO (STYLIZED). U.S. CL. 13. (INT. CL. 9). REG. 2-26-1952.	927,855.	SUNNY DOODLES. U.S. CL. 46. (INT. CL. 30). REG. 1-25-1972.
555,846.	MISCELLANEOUS DESIGN. U.S. CL. 38. (INT. CL. 16). REG. 3-11-1952.	929,019.	FUNGASSAY. U.S. CL. 18. (INT. CL. 5). REG. 2-15-1972.
556,998.	GUIDEROL (STYLIZED). U.S. CL. 23. (INT. CL. 7). REG. 4-1-1952.	929,505.	REMINGTON. U.S. CL. 23. (INT. CL. 7). REG. 2-22-1972.
559,945.	KYMENE (STYLIZED). U.S. CL. 6. (INT. CL. 1). REG. 6-10-1952.	929,735.	ARIEL. U.S. CL. 52. (INT. CL. 3). REG. 2-22-1972.
562,516.	CANTEEN. U.S. CL. 2. (INT. CL. 21). REG. 8-5-1952.	929,941.	SPEED-O-BALL. U.S. CL. 22. (INT. CL. 28). REG. 2-29-1972.
570,011.	BOSS AND DESIGN. U.S. CL. 39. (INT. CL. 25). REG. 2-3-1953.	933,490.	T&R. U.S. CL. 21. (INT. CL. 9). REG. 5-9-1972.
717,320.	THE CHASE MANHATTAN BANK. U.S. CL. 102. (INT. CL. 36). REG. 6-20-1961.	934,647.	WHITE HEN PANTRY. U.S. CL. 101. (INT. CL. 42). REG. 5-23-1972.
720,013.	WILSON JONES. U.S. CL. 37. (INT. CL. 16). REG. 8-15-1961.	934,648.	MISCELLANEOUS DESIGN. U.S. CL. 101. (INT. CL. 42). REG. 5-23-1972.
723,479.	PRESTIGE. U.S. CL. 13. (INT. CL. 21). REG. 11-7-1961.	934,651.	MORVEN PARK. U.S. CL. 107. (INT. CL. 41). REG. 5-23-1972.
724,510.	DAY-FLO. U.S. CL. 35. (INT. CL. 17). REG. 11-28-1961.	935,078.	HEX. U.S. CL. 51. (INT. CL. 5). REG. 5-30-1972.
		936,318.	EXPLORATORIUM. U.S. CL. 107. (INT. CL. 41). REG. 6-20-1972.
		936,452.	ENDURALAC. U.S. CL. 16. (INT. CL. 2). REG. 6-27-1972.

- 940,446. STX (STYLIZED). U.S. CL. 22. (INT. CL. 28). REG. 8-8-1972.
- 941,210. FOUNTAIN BLEU. U.S. CL. 6. (INT. CL. 2). REG. 8-22-1972.
- 942,339. DWYER AND DESIGN. U.S. CL. 26. (INT. CL. 9). REG. 9-5-1972.
- 945,185. ACE AND DESIGN. U.S. CL. 23. (INT. CL. 7). REG. 10-17-1972.
- 948,572. ARCH. U.S. CL. 38. (INT. CL. 16). REG. 12-12-1972.
- 948,771. CRELLIN. U.S. CL. 2. (INT. CL. 20). REG. 12-19-1972.
- 952,167. BASSETT. U.S. CL. 44. (INT. CL. 8). REG. 1-30-1973.
- 952,764. MRS. WAGES. U.S. CL. 46. (INT. CL. 1). REG. 2-6-1973.
- 1,157,925. HIPPO (STYLIZED). INT. CL. 9. (U.S. CL. 21). REG. 6-23-1981.
- 1,158,264. BALIN. INT. CL. 28. (U.S. CL. 22). REG. 6-23-1981.
- 1,158,272. STEVE'S ICE CREAM. INT. CL. 30. (U.S. CL. 46). REG. 6-23-1981.
- 1,160,755. FOGLESS (STYLIZED). INT. CL. 9. (U.S. CL. 26). REG. 7-14-1981.
- 1,161,042. FOXLAND. INT. CL. 25. (U.S. CL. 39). REG. 7-14-1981.
- 1,161,164. REDI GRILL. INT. CL. 29. (U.S. CL. 46). REG. 7-14-1981.
- 1,161,254. AD-BUILDER. INT. CL. 35. (U.S. CL. 101). REG. 7-14-1981.
- 1,165,714. FAMILY FEAST. INT. CL. 29. (U.S. CL. 46). REG. 8-18-1981.
- 1,167,165. QUADRACART. INT. CL. 12. (U.S. CL. 19). REG. 9-1-1981.
- 1,168,541. TOM KITTEN. INT. CL. 28. (U.S. CL. 22). REG. 9-8-1981.
- 1,170,737. NOCSAE. U.S. CL. A. REG. 9-22-1981.
- 1,176,876. UNIT. INT. CL. 7. (U.S. CLS. 13, 19, 21, 23, 31, 34 AND 35). REG. 11-10-1981.
- 1,177,075. CONTRA/CLINE. INT. CL. 11. (U.S. CL. 21). REG. 11-10-1981.
- 1,178,554. FANTASTIC FOUR. INT. CL. 41. (U.S. CL. 107). REG. 11-17-1981.
- 1,179,644. BLUELIGHT SPECIAL STANDARD CHARACTER MARK. INT. CL. 42. (U.S. CL. 101). REG. 11-24-1981.
- 1,181,571. MISCELLANEOUS DESIGN. INT. CL. 41. (U.S. CL. 107). REG. 12-8-1981.
- 1,182,937. PERGUT. INT. CL. 17. (U.S. CL. 1). REG. 12-22-1981.
- 1,182,947. SUPERMAN. INT. CL. 18. (U.S. CL. 3). REG. 12-22-1981.
- 1,183,091. KOOKABURRA. INT. CL. 28. (U.S. CL. 22). REG. 12-22-1981.
- 1,183,208. SUCCESS MEASURED BY PROVEN ABILITY. INT. CL. 36. (U.S. CLS. 100, 101 AND 102). REG. 12-22-1981.
- 1,183,253. MOTHER OF THE YEAR. INT. CL. 41. (U.S. CL. 107). REG. 12-22-1981.
- 1,183,497. UNIT MARINER CRANES AND DESIGN. INT. CL. 7. (U.S. CL. 23). REG. 12-29-1981.
- 1,183,583. BANCTEC. INT. CL. 9 ONLY. (U.S. CL. 26). REG. 12-29-1981.
- 1,183,619. HOWMEDICA MIX-KIT. INT. CL. 10. (U.S. CL. 44). REG. 12-29-1981.
- 1,183,678. DURA-DISC. INT. CL. 12. (U.S. CLS. 19, 21, 23, 31, 35 AND 44). REG. 12-29-1981.
- 1,183,788. PEDLOCK. INT. CL. 20. (U.S. CL. 50). REG. 12-29-1981.
- 1,183,809. SUPERMAN (STYLIZED). INT. CL. 21. (U.S. CLS. 2, 13, 23, 29, 30, 33, 40 AND 50). REG. 12-29-1981.
- 1,183,834. NO-SHOCK. INT. CL. 22. (U.S. CL. 1). REG. 12-29-1981.
- 1,183,841. SUPERMAN. INT. CL. 24. (U.S. CLS. 42 AND 50). REG. 12-29-1981.
- 1,183,868. CASTAWAYS. INT. CL. 25. (U.S. CL. 39). REG. 12-29-1981.
- 1,183,907. BONAVENTURE. INT. CL. 25. (U.S. CLS. 22 AND 39). REG. 12-29-1981.
- 1,183,992. LA MONEGASQUE. INT. CL. 29. (U.S. CL. 46). REG. 12-29-1981.
- 1,184,135. THE MAIDS AND DESIGN. INT. CL. 37. (U.S. CL. 103). REG. 12-29-1981.
- 1,184,216. ABBY'S PIZZA AND DESIGN. INT. CL. 42. (U.S. CL. 100). REG. 12-29-1981.
- 1,184,290. VERSAR. INT. CLS. 37, 41 AND 42 ONLY. (U.S. CLS. 100, 103 AND 107 ONLY). REG. 1-5-1982.
- 1,184,318. HYONIC. INT. CL. 1. (U.S. CL. 6). REG. 1-5-1982.
- 1,184,354. PRE-TESTED (STYLIZED). INT. CL. 2. (U.S. CL. 16). REG. 1-5-1982.
- 1,184,389. BRITE EYES (STYLIZED). INT. CL. 3. (U.S. CL. 4). REG. 1-5-1982.
- 1,184,405. NOPCOTE. INT. CL. 4. (U.S. CL. 15). REG. 1-5-1982.
- 1,184,565. CHRISTIE. INT. CL. 9. (U.S. CL. 26). REG. 1-5-1982.
- 1,184,601. BIO-SHIELD. INT. CL. 10. (U.S. CL. 44). REG. 1-5-1982.
- 1,184,733. REDI. INT. CL. 21 ONLY. (U.S. CLS. 2 AND 3). REG. 1-5-1982.
- 1,184,813. GREENS KEEPER. INT. CL. 20. (U.S. CLS. 2, 13, 22, 25, 32 AND 50). REG. 1-5-1982.
- 1,184,823. SAFE-COTE. INT. CL. 21. (U.S. CL. 2). REG. 1-5-1982.
- 1,185,018. LAMB WESTON (STYLIZED). INT. CL. 29. (U.S. CL. 46). REG. 1-5-1982.
- 1,185,083. VANITY. INT. CL. 31. (U.S. CL. 46). REG. 1-5-1982.
- 1,185,243. U H S. INT. CL. 42. (U.S. CL. 100). REG. 1-5-1982.
- 1,185,291. BARACOR. INT. CL. 1. (U.S. CL. 6). REG. 1-12-1982.
- 1,185,314. LEUKOTAN. INT. CL. 1. (U.S. CL. 6). REG. 1-12-1982.
- 1,185,640. MILK CHECK. INT. CL. 11. (U.S. CL. 31). REG. 1-12-1982.
- 1,185,839. CHIX. INT. CL. 21. (U.S. CL. 29). REG. 1-12-1982.
- 1,185,868. DE LONG. INT. CL. 25. (U.S. CL. 39). REG. 1-12-1982.
- 1,185,897. BUFFALO. INT. CL. 25. (U.S. CL. 39). REG. 1-12-1982.
- 1,186,016. HO-MILC. INT. CL. 29. (U.S. CL. 46). REG. 1-12-1982.
- 1,186,029. ROCKY ROCOCO. INT. CLS. 30 AND 42. (U.S. CLS. 46 AND 100). REG. 1-12-1982.
- 1,186,259. AMBERSEP. INT. CL. 1. (U.S. CL. 1). REG. 1-19-1982.
- 1,187,012. POMMERY. INT. CL. 30. (U.S. CL. 46). REG. 1-19-1982.
- 1,187,304. SISLEY AND DESIGN. INT. CL. 3. (U.S. CLS. 51 AND 52). REG. 1-26-1982.
- 1,187,308. CERAMID. INT. CL. 4. (U.S. CL. 15). REG. 1-26-1982.
- 1,187,714. CHIX AND DESIGN. INT. CL. 21. (U.S. CL. 29). REG. 1-26-1982.
- 1,187,914. KITCHEN FRIES. INT. CL. 29. (U.S. CL. 46). REG. 1-26-1982.
- 1,188,845. "THE CRACKER BREAD BAKERS". INT. CL. 30. (U.S. CL. 46). REG. 2-2-1982.
- 1,189,767. BIELOMATIK (STYLIZED). INT. CLS. 7 AND 9. (U.S. CLS. 13, 19, 21, 23, 26, 31, 34 AND 35). REG. 2-16-1982.
- 1,189,814. ARC WATER AND DESIGN. INT. CL. 9. (U.S. CLS. 13, 34 AND 35). REG. 2-16-1982.
- 1,189,845. PERFECT PAIR. INT. CL. 9. (U.S. CL. 21). REG. 2-16-1982.
- 1,189,890. MUELLER MIRROR. INT. CL. 10. (U.S. CL. 44). REG. 2-16-1982.
- 1,189,929. S-76. INT. CL. 12. (U.S. CL. 19). REG. 2-16-1982.
- 1,190,090. THE FINEST IN THE FIELD. INT. CL. 28. (U.S. CLS. 22, 23, 38 AND 50). REG. 2-16-1982.
- 1,190,160. DILETTANTE. INT. CLS. 30 AND 42. (U.S. CLS. 46, 100 AND 101). REG. 2-16-1982.
- 1,190,244. OLD CHICAGO. INT. CL. 42 ONLY. (U.S. CL. 100). REG. 2-16-1982.
- 1,190,443. HOLMATRO. INT. CL. 7. (U.S. CLS. 13, 19, 21, 23, 31, 34 AND 35). REG. 2-23-1982.
- 1,190,507. ARCWATER. INT. CL. 9. (U.S. CLS. 13, 34 AND 35). REG. 2-23-1982.
- 1,190,586. Q AND DESIGN. INT. CL. 10. (U.S. CL. 44). REG. 2-23-1982.
- 1,190,773. SIROCCO. INT. CL. 25. (U.S. CL. 39). REG. 2-23-1982.
- 1,190,942. M. PALADINO, INC. AND DESIGN. INT. CL. 37. (U.S. CLS. 100 AND 103). REG. 2-23-1982.
- 1,191,280. PEANUT BUSTER. INT. CL. 30. (U.S. CL. 46). REG. 3-2-1982.
- 1,191,361. H-OIL. INT. CLS. 37 AND 42. (U.S. CLS. 100 AND 103). REG. 3-2-1982.
- 1,191,462. BUBBLEKUP. INT. CL. 1. (U.S. CL. 1). REG. 3-9-1982.
- 1,191,740. V AND DESIGN. INT. CL. 25. (U.S. CLS. 22 AND 39). REG. 3-9-1982.

- 1,191,816. NEWPORT AND DESIGN. INT. CL. 34. (U.S. CL. 17). REG. 3-9-1982.
- 1,192,052. F AND DESIGN. INT. CL. 10. (U.S. CL. 44). REG. 3-16-1982.
- 1,192,121. MEIJER. INT. CLS. 40 AND 42 ONLY. (U.S. CLS. 100, 101 AND 106). REG. 3-16-1982.
- 1,192,225. SNOQUALMIE FALLS LODGE. INT. CL. 30 ONLY. (U.S. CL. 46). REG. 3-16-1982.
- 1,192,311. MISCELLANEOUS DESIGN. INT. CL. 41. (U.S. CL. 107). REG. 3-16-1982.
- 1,192,552. LUTRADUR. INT. CLS. 22, 23 AND 24. (U.S. CLS. 1, 2, 7, 19, 22, 42, 43 AND 50). REG. 3-23-1982.
- 1,193,467. JOWAT. INT. CL. 1. (U.S. CLS. 1, 5 AND 6). REG. 4-13-1982.
- 1,193,821. PRAESTOL. INT. CL. 1. (U.S. CL. 6). REG. 4-20-1982.
- 1,194,187. FURA-OINTMENT. INT. CL. 5. (U.S. CL. 18). REG. 4-27-1982.
- 1,194,437. PRO STAFF. INT. CL. 35. (U.S. CL. 101). REG. 4-27-1982.
- 1,194,474. THE DRIVER'S SEAT. INT. CL. 42. (U.S. CL. 100). REG. 4-27-1982.
- 1,194,852. MISCELLANEOUS DESIGN. INT. CL. 36. (U.S. CL. 102). REG. 5-4-1982.
- 1,196,886. KEY IMPERIAL AND DESIGN. INT. CL. 25. (U.S. CL. 39). REG. 6-1-1982.
- 1,197,635. HI-HEALTH AND DESIGN. INT. CL. 5. (U.S. CL. 18). REG. 6-15-1982.
- 1,197,636. ARTI-FOL. INT. CL. 5. (U.S. CL. 44). REG. 6-15-1982.
- 1,197,696. WARD. INT. CL. 6. (U.S. CL. 14). REG. 6-15-1982.
- 1,198,392. THYMLY PRODUCTS, INC.. INT. CLS. 1 AND 30. (U.S. CLS. 6 AND 46). REG. 6-22-1982.
- 1,198,720. CURRENT PROBLEMS IN CARDIOLOGY. INT. CL. 16. (U.S. CL. 38). REG. 6-22-1982.
- 1,200,239. ORACLE. INT. CLS. 9 AND 16. (U.S. CLS. 21, 23, 26, 36 AND 38). REG. 7-6-1982.
- 1,201,281. S AND DESIGN. INT. CL. 28. (U.S. CL. 22). REG. 7-13-1982.
- 1,201,318. MISCELLANEOUS DESIGN. INT. CL. 29. (U.S. CL. 46). REG. 7-13-1982.
- 1,202,943. ONE HOUR MARTINIZING. INT. CL. 35. (U.S. CL. 101). REG. 7-27-1982.
- 1,202,954. MARTINIZING. INT. CL. 35. (U.S. CL. 101). REG. 7-27-1982.
- 1,203,093. KITTY HAWK KITES AND DESIGN. INT. CLS. 41 AND 42. (U.S. CLS. 101 AND 107). REG. 7-27-1982.
- 1,204,472. ENERGY DETENTE. INT. CL. 16. (U.S. CL. 38). REG. 8-10-1982.
- 1,205,201. A AND DESIGN. INT. CL. 9. (U.S. CLS. 23 AND 26). REG. 8-17-1982.
- 1,205,626. MISCELLANEOUS DESIGN. INT. CL. 30. (U.S. CL. 46). REG. 8-17-1982.
- 1,211,135. SYNCHRON. INT. CL. 1. (U.S. CL. 6). REG. 10-5-1982.
- 1,212,059. POLO RALPH LAUREN (STYLIZED). INT. CL. 3. (U.S. CLS. 1, 4, 6, 50, 51 AND 52). REG. 10-12-1982.
- 1,212,787. HI-HEALTH AND DESIGN. INT. CL. 42. (U.S. CL. 101). REG. 10-12-1982.
- 1,213,243. ELECORN. INT. CL. 15. (U.S. CL. 36). REG. 10-19-1982.
- 1,218,501. SQUARE ONE. INT. CL. 28. (U.S. CL. 22). REG. 11-30-1982.
- 1,219,463. THE GREAT AMUSEMENT EMPORIUM. INT. CL. 42. (U.S. CLS. 100 AND 101). REG. 12-7-1982.
- 1,219,615. SLIPPERY STUFF. INT. CL. 3. (U.S. CL. 51). REG. 12-14-1982.
- 1,220,905. MC MCFARLAND CASCADE (STYLIZED). INT. CL. 19. (U.S. CL. 12). REG. 12-21-1982.
- 1,221,211. MISCELLANEOUS DESIGN. INT. CLS. 40 AND 42. (U.S. CLS. 100 AND 106). REG. 12-21-1982.
- 1,221,918. BATTLE CAT. INT. CL. 28. (U.S. CL. 22). REG. 12-28-1982.
- 1,643,047. THE GREAT WALLENDAS CIRCUS. INT. CL. 41. (U.S. CL. 107). REG. 4-30-1991.
- 1,649,569. YBS. INT. CL. 26. (U.S. CL. 39). REG. 7-2-1991.
- 1,649,600. FARMLAND EXTRA TENDER. INT. CL. 29. (U.S. CL. 46). REG. 7-2-1991.
- 1,650,166. DIFFRACTAL. INT. CL. 19. (U.S. CL. 12). REG. 7-9-1991.
- 1,650,822. DE LONG USA. INT. CL. 25. (U.S. CL. 39). REG. 7-16-1991.
- 1,651,112. FOREIGN SCOUTING SERVICE. INT. CL. 42. (U.S. CL. 100). REG. 7-16-1991.
- 1,652,696. WIREXPRESS (STYLIZED). INT. CL. 42. (U.S. CL. 101). REG. 7-30-1991.
- 1,654,276. UNIPISTON. INT. CL. 12. (U.S. CL. 19). REG. 8-20-1991.
- 1,654,360. XOREL. INT. CL. 24. (U.S. CLS. 40 AND 42). REG. 8-20-1991.
- 1,654,714. D DROPSA AND DESIGN. INT. CLS. 6, 7 AND 9. (U.S. CLS. 2, 13, 21, 23 AND 26). REG. 8-27-1991.
- 1,657,425. PATIO PAL. INT. CL. 19. (U.S. CL. 12). REG. 9-17-1991.
- 1,658,410. DON MARCOS AND DESIGN. INT. CL. 30. (U.S. CL. 46). REG. 9-24-1991.
- 1,659,752. LAPINUS. INT. CL. 17. (U.S. CLS. 35 AND 50). REG. 10-8-1991.
- 1,660,741. G AND DESIGN. INT. CL. 12. (U.S. CL. 19). REG. 10-15-1991.
- 1,662,085. MISCELLANEOUS DESIGN. INT. CL. 42. (U.S. CL. 100). REG. 10-22-1991.
- 1,665,411. ODYSSEY. INT. CL. 8. (U.S. CL. 23). REG. 11-19-1991.
- 1,666,147. UNIVERSITY OF ARKANSAS VERITATE DUCE PROGREDI 1871 AND DESIGN. INT. CL. 41. (U.S. CL. 107). REG. 11-26-1991.
- 1,666,331. CRYSTALAC. INT. CL. 1. (U.S. CL. 6). REG. 12-3-1991.
- 1,666,594. STEEL GRIP. INT. CL. 9. (U.S. CLS. 21, 23, 26, 36 AND 38). REG. 12-3-1991.
- 1,668,302. DIGITARC. INT. CL. 9. (U.S. CLS. 26 AND 38). REG. 12-17-1991.
- 1,668,478. DTAIL. INT. CL. 16. (U.S. CL. 38). REG. 12-17-1991.
- 1,668,479. LEGENDARY SERVICE. INT. CL. 16. (U.S. CL. 38). REG. 12-17-1991.
- 1,668,722. COUNTRY FEEDS. INT. CL. 31. (U.S. CL. 46). REG. 12-17-1991.
- 1,668,761. IMG. INT. CLS. 35 AND 36. (U.S. CLS. 101 AND 102). REG. 12-17-1991.
- 1,669,022. STEEL VALLEY. INT. CL. 42. (U.S. CL. 100). REG. 12-17-1991.
- 1,669,057. GENOSORB. INT. CL. 1. (U.S. CL. 6). REG. 12-24-1991.
- 1,669,063. HOSTAFINE. INT. CL. 2. (U.S. CLS. 6, 11 AND 16). REG. 12-24-1991.
- 1,669,130. SPACEMASTER. INT. CL. 6. (U.S. CL. 50). REG. 12-24-1991.
- 1,669,159. EDM. INT. CL. 7. (U.S. CLS. 13, 19, 21, 23, 31, 34 AND 35). REG. 12-24-1991.
- 1,669,536. COTTONS' POINT. INT. CL. 25. (U.S. CL. 39). REG. 12-24-1991.
- 1,669,540. SECRET HUG. INT. CL. 25. (U.S. CLS. 22 AND 39). REG. 12-24-1991.
- 1,669,646. AMERICAN VINTAGE. INT. CL. 30. (U.S. CL. 46). REG. 12-24-1991.
- 1,669,648. MOORE-CLARK. INT. CL. 31. (U.S. CL. 46). REG. 12-24-1991.
- 1,669,662. THELMA'S OLD FASHIONED LEMONADE AND DESIGN. INT. CL. 32. (U.S. CL. 45). REG. 12-24-1991.
- 1,669,663. THELMA'S OLD FASHIONED PINK LEMONADE AND DESIGN. INT. CL. 32. (U.S. CL. 45). REG. 12-24-1991.
- 1,669,738. CLEAN, FRESH & BRIGHT. INT. CL. 37. (U.S. CL. 103). REG. 12-24-1991.
- 1,669,777. MUSIC BY REQUEST. INT. CL. 41. (U.S. CL. 107). REG. 12-24-1991.
- 1,669,837. LUNKER'S. INT. CL. 42. (U.S. CL. 101). REG. 12-24-1991.
- 1,669,861. COLD NOSES AND DESIGN. INT. CL. 42. (U.S. CL. 101). REG. 12-24-1991.
- 1,669,919. U AND DESIGN. INT. CL. 42. (U.S. CL. 101). REG. 12-24-1991.
- 1,669,929. CHADWICK. INT. CL. 16. (U.S. CL. 37). REG. 12-24-1991.
- 1,670,037. DUO-FLIP. INT. CL. 6. (U.S. CL. 50). REG. 12-31-1991.
- 1,670,151. SCANLAN ULTRA SHARP. INT. CL. 10. (U.S. CL. 44). REG. 12-31-1991.
- 1,670,326. RIKIO. INT. CL. 25. (U.S. CL. 39). REG. 12-31-1991.
- 1,670,372. CRAPPIE BUSTER. INT. CL. 28. (U.S. CLS. 22, 23, 38 AND 50). REG. 12-31-1991.
- 1,670,439. MISCELLANEOUS DESIGN. INT. CL. 32. (U.S. CL. 48). REG. 12-31-1991.
- 1,670,550. WORLD TREK AND DESIGN. INT. CL. 39. (U.S. CL. 105). REG. 12-31-1991.

- 1,670,667. THE ST. PAUL. INT. CL. 42. (U.S. CL. 100). REG. 12-31-1991.
- 1,670,841. DREXLITE. INT. CL. 25. (U.S. CL. 39). REG. 12-31-1991.
- 1,670,964. IBEDA. INT. CLS. 7 AND 8 ONLY. (U.S. CL. 23). REG. 1-7-1992.
- 1,670,975. TROY VALVE. INT. CL. 7. (U.S. CLS. 13 AND 23). REG. 1-7-1992.
- 1,670,976. FFC AND DESIGN. INT. CL. 7. (U.S. CL. 23). REG. 1-7-1992.
- 1,671,044. JACK. INT. CL. 9. (U.S. CL. 38). REG. 1-7-1992.
- 1,671,054. MISCELLANEOUS DESIGN. INT. CL. 11. (U.S. CL. 13). REG. 1-7-1992.
- 1,671,076. SWATCH. INT. CL. 14. (U.S. CL. 27). REG. 1-7-1992.
- 1,671,098. FLEER. INT. CL. 16. (U.S. CL. 38). REG. 1-7-1992.
- 1,671,190. MISCELLANEOUS DESIGN. INT. CL. 25. (U.S. CL. 39). REG. 1-7-1992.
- 1,671,192. MISCELLANEOUS DESIGN. INT. CL. 25. (U.S. CL. 39). REG. 1-7-1992.
- 1,671,279. TUNA CLASSIC. INT. CL. 30. (U.S. CL. 46). REG. 1-7-1992.
- 1,671,349. JWC ENVIRONMENTAL AND DESIGN. INT. CLS. 37 AND 42. (U.S. CLS. 101 AND 103). REG. 1-7-1992.
- 1,671,419. ZIBA. INT. CL. 42. (U.S. CLS. 100 AND 101). REG. 1-7-1992.
- 1,671,446. IPA. U.S. CL. 200. REG. 1-7-1992.
- 1,671,461. SOLEXTRA. INT. CL. 12. (U.S. CLS. 19 AND 33). REG. 1-7-1992.
- 1,671,487. UNITED ELECTRIC SUPPLY (STYLIZED). INT. CL. 42. (U.S. CL. 101). REG. 1-7-1992.
- 1,671,511. ALERT. INT. CL. 1. (U.S. CL. 6). REG. 1-14-1992.
- 1,671,555. CHINA RAIN. INT. CL. 3. (U.S. CLS. 1, 6, 50, 51 AND 52). REG. 1-14-1992.
- 1,671,594. CONTROL. INT. CL. 9. (U.S. CL. 38). REG. 1-14-1992.
- 1,671,656. ADAPTEC. INT. CL. 9. (U.S. CLS. 21, 26 AND 38). REG. 1-14-1992.
- 1,671,670. THERACOLD. INT. CL. 10. (U.S. CL. 44). REG. 1-14-1992.
- 1,671,922. WHITE CLOVER. INT. CL. 29. (U.S. CL. 46). REG. 1-14-1992.
- 1,671,939. BACHMAN JAX AND DESIGN. INT. CL. 30. (U.S. CL. 46). REG. 1-14-1992.
- 1,672,127. THE MORE YOU KNOW. INT. CL. 41. (U.S. CL. 107). REG. 1-14-1992.
- 1,672,200. LAND'S END. INT. CL. 42. (U.S. CL. 100). REG. 1-14-1992.
- 1,672,241. GMS. INT. CL. 42. (U.S. CL. 100). REG. 1-14-1992.
- 1,672,424. PARALAN AND DESIGN. INT. CL. 9. (U.S. CLS. 21 AND 26). REG. 1-21-1992.
- 1,672,865. HOME VALUES & GIFTS. INT. CL. 42. (U.S. CL. 101). REG. 1-21-1992.
- 1,672,927. DIGILUBE SYSTEMS. INT. CLS. 4 AND 42. (U.S. CLS. 15 AND 101). REG. 1-21-1992.
- 1,673,014. PRECISION-ANGLE. INT. CL. 21. (U.S. CL. 29). REG. 1-21-1992.
- 1,673,112. VOLTAGE SCANNER. INT. CL. 9. (U.S. CL. 26). REG. 1-21-1992.
- 1,673,186. AVTAINER. INT. CL. 6. (U.S. CL. 13). REG. 1-28-1992.
- 1,673,336. KENA AND DESIGN. INT. CL. 9. (U.S. CLS. 21, 23 AND 26). REG. 1-28-1992.
- 1,673,349. ANTIZAP AND DESIGN. INT. CL. 9. (U.S. CLS. 21 AND 26). REG. 1-28-1992.
- 1,673,350. GAUGE-IT. INT. CL. 9. (U.S. CL. 26). REG. 1-28-1992.
- 1,673,897. M/J MAR-JAC AND DESIGN. INT. CL. 29. (U.S. CL. 46). REG. 1-28-1992.
- 1,674,507. FIRST BUSINESS BROKERS LTD.. INT. CL. 36. (U.S. CLS. 101 AND 102). REG. 2-4-1992.
- 1,674,679. WILLOW DRIVE. INT. CL. 42. (U.S. CLS. 100, 101 AND 103). REG. 2-4-1992.
- 1,674,863. THE DONUT MAN. INT. CLS. 9 AND 41. (U.S. CLS. 36 AND 107). REG. 2-11-1992.
- 1,674,981. TRACKER. INT. CL. 12. (U.S. CL. 19). REG. 2-11-1992.
- 1,674,992. WMJ. INT. CL. 14. (U.S. CL. 28). REG. 2-11-1992.
- 1,675,069. WRIGHTLON. INT. CL. 17. (U.S. CLS. 1, 5, 12, 13, 35 AND 50). REG. 2-11-1992.
- 1,675,072. ALCEN FIBER. INT. CL. 17. (U.S. CLS. 12 AND 35). REG. 2-11-1992.
- 1,675,104. COOLTHANE. INT. CL. 20. (U.S. CL. 2). REG. 2-11-1992.
- 1,675,526. PEACE OF MIND. INT. CL. 3. (U.S. CL. 51). REG. 2-11-1992.
- 1,675,639. AQUA NEWS. INT. CL. 2. (U.S. CL. 11). REG. 2-18-1992.
- 1,675,657. FAILSAFE. INT. CL. 3. (U.S. CL. 52). REG. 2-18-1992.
- 1,675,658. KLENZTONE. INT. CL. 3. (U.S. CLS. 6 AND 52). REG. 2-18-1992.
- 1,675,758. SCANTEL (STYLIZED). INT. CL. 9. (U.S. CL. 26). REG. 2-18-1992.
- 1,675,826. CALTECH. INT. CL. 16. (U.S. CL. 38). REG. 2-18-1992.
- 1,676,148. FITZGERALDS AND DESIGN. INT. CL. 41. (U.S. CL. 107). REG. 2-18-1992.
- 1,676,195. RADIO SHACK. INT. CL. 42. (U.S. CLS. 100 AND 101). REG. 2-18-1992.
- 1,676,217. HEALTH BEST. INT. CL. 42. (U.S. CL. 101). REG. 2-18-1992.
- 1,676,228. THE FIRE HOUSE CASUAL LIVING STORE AND DESIGN. INT. CL. 42. (U.S. CL. 101). REG. 2-18-1992.
- 1,676,237. RUBY RED'S. INT. CL. 42. (U.S. CL. 100). REG. 2-18-1992.
- 1,676,311. CALIBRA. INT. CL. 9. (U.S. CL. 26). REG. 2-18-1992.
- 1,676,376. UNI-PALLET. INT. CL. 20. (U.S. CL. 50). REG. 2-18-1992.
- 1,676,421. MISCELLANEOUS DESIGN. INT. CL. 11. (U.S. CL. 31). REG. 2-18-1992.
- 1,676,578. CW. INT. CL. 7. (U.S. CL. 23). REG. 2-25-1992.
- 1,676,599. SUBLIMINAL. INT. CL. 9. (U.S. CL. 38). REG. 2-25-1992.
- 1,676,675. SPIROTUBE. INT. CL. 11. (U.S. CL. 34). REG. 2-25-1992.
- 1,676,687. ERATECH. INT. CL. 11. (U.S. CL. 34). REG. 2-25-1992.
- 1,676,794. FLAME CURB. INT. CL. 19. (U.S. CL. 12). REG. 2-25-1992.
- 1,676,948. BIRD COUNTRY. INT. CL. 31. (U.S. CL. 1). REG. 2-25-1992.
- 1,677,346. MISCELLANEOUS DESIGN. INT. CL. 6. (U.S. CL. 13). REG. 3-3-1992.
- 1,677,436. CHATILLON. INT. CL. 9. (U.S. CL. 26). REG. 3-3-1992.
- 1,677,484. DLP. INT. CL. 10. (U.S. CLS. 26, 39 AND 44). REG. 3-3-1992.
- 1,677,604. ERIK'S AND DESIGN. INT. CL. 16. (U.S. CLS. 2 AND 37). REG. 3-3-1992.
- 1,677,853. PHI. INT. CL. 36. (U.S. CLS. 100, 101 AND 102). REG. 3-3-1992.
- 1,677,913. SPORTSCARE AND DESIGN. INT. CL. 41. (U.S. CL. 107). REG. 3-3-1992.
- 1,677,921. SCIENCE SPECTRUM. INT. CL. 41. (U.S. CL. 107). REG. 3-3-1992.
- 1,678,177. MODAR. INT. CL. 1. (U.S. CL. 6). REG. 3-10-1992.
- 1,678,366. IDEAWORKS AND DESIGN. INT. CL. 9. (U.S. CL. 29). REG. 3-10-1992.
- 1,678,437. PGA PROFESSIONAL GOLFERS' ASSOCIATION OF AMERICA AND DESIGN. INT. CLS. 14, 25 AND 28. (U.S. CLS. 22, 28 AND 39). REG. 3-10-1992.
- 1,678,674. UNITRACK. INT. CL. 28. (U.S. CL. 22). REG. 3-10-1992.
- 1,679,162. S (STYLIZED). INT. CL. 6. (U.S. CL. 13). REG. 3-17-1992.
- 1,679,579. EUROFRESH. INT. CL. 31. (U.S. CL. 46). REG. 3-17-1992.
- 1,679,841. MINIMAX. INT. CL. 10. (U.S. CL. 44). REG. 3-17-1992.
- 1,681,581. CAGE-KLENZ. INT. CL. 3. (U.S. CL. 52). REG. 3-31-1992.
- 1,681,643. JAL AND DESIGN. INT. CL. 39. (U.S. CL. 105). REG. 3-31-1992.
- 1,681,729. PINE TIME. INT. CL. 3. (U.S. CL. 52). REG. 4-7-1992.
- 1,681,756. TITAN. INT. CL. 6. (U.S. CL. 12). REG. 4-7-1992.
- 1,682,816. PATRIOT 80 PLUS. INT. CL. 11. (U.S. CL. 34). REG. 4-14-1992.
- 1,684,122. EASY HOLD. INT. CL. 8. (U.S. CLS. 23, 44 AND 50). REG. 4-21-1992.
- 1,684,425. UNOFFICIAL. INT. CL. 16. (U.S. CL. 38). REG. 4-28-1992.

- 1,684,584. SHAMU. INT. CL. 30. (U.S. CL. 46). REG. 4-28-1992.
- 1,685,767. VISION. INT. CL. 9. (U.S. CL. 26). REG. 5-5-1992.
- 1,686,323. IV. INT. CL. 14. (U.S. CLS. 27 AND 28). REG. 5-12-1992.
- 1,687,078. OMNISORB. INT. CL. 10. (U.S. CL. 44). REG. 5-12-1992.
- 1,687,291. NATURE'S WINDOW. INT. CL. 31. (U.S. CL. 46). REG. 5-12-1992.
- 1,689,072. ICF. INT. CL. 20. (U.S. CL. 32). REG. 5-26-1992.
- 1,690,051. RING-JET STANDARD CHARACTER MARK. INT. CL. 11. (U.S. CL. 13). REG. 6-2-1992.
- 1,690,553. THE MARTIN & OSA JOHNSON SAFARI MUSEUM. INT. CL. 41. (U.S. CL. 107). REG. 6-2-1992.
- 1,691,192. CORONA. INT. CL. 8. (U.S. CL. 23). REG. 6-9-1992.
- 1,691,533. ACE. INT. CL. 16. (U.S. CL. 38). REG. 6-9-1992.
- 1,691,795. A AND DESIGN. INT. CL. 30. (U.S. CL. 46). REG. 6-9-1992.
- 1,691,865. CLERI MODELS AND DESIGN. INT. CL. 35. (U.S. CL. 100). REG. 6-9-1992.
- 1,691,935. ESBA CAPITAL GROUP, INC.. INT. CL. 36. (U.S. CLS. 100, 101 AND 102). REG. 6-9-1992.
- 1,692,402. DESIGN SPAN. INT. CL. 6. (U.S. CL. 12). REG. 6-9-1992.
- 1,694,237. J&M (STYLIZED). INT. CL. 12. (U.S. CL. 19). REG. 6-16-1992.
- 1,694,286. BEST'S KEY RATING GUIDE. INT. CL. 16. (U.S. CL. 38). REG. 6-16-1992.
- 1,694,497. MISCELLANEOUS DESIGN. INT. CL. 25. (U.S. CLS. 22 AND 39). REG. 6-16-1992.
- 1,695,840. NKK. INT. CL. 9. (U.S. CLS. 21, 23, 26, 36 AND 38). REG. 6-23-1992.
- 1,696,276. BUCKEYE BEANS & HERBS. INT. CL. 29. (U.S. CL. 46). REG. 6-23-1992.
- 1,696,371. BLACK SATIN. INT. CL. 31. (U.S. CL. 1). REG. 6-23-1992.
- 1,696,519. COSTA RICA CONNECTION. INT. CL. 39. (U.S. CL. 105). REG. 6-23-1992.
- 1,696,899. HELIOS. INT. CL. 11. (U.S. CL. 34). REG. 6-23-1992.
- 1,697,263. MULTILOBE (STYLIZED). INT. CL. 1. (U.S. CL. 6). REG. 6-30-1992.
- 1,698,759. MINERALLAC. INT. CL. 6. (U.S. CLS. 12 AND 13). REG. 7-7-1992.
- 1,699,763. CELLTRON. INT. CL. 9. (U.S. CL. 21). REG. 7-7-1992.
- 1,700,329. LEAD CUFF. INT. CL. 9. (U.S. CL. 26). REG. 7-14-1992.
- 1,700,991. AV (STYLIZED). INT. CL. 42. (U.S. CL. 101). REG. 7-14-1992.
- 1,701,823. CENTURY. INT. CL. 20. (U.S. CL. 32). REG. 7-21-1992.
- 1,703,851. AUTORAMA. INT. CL. 41. (U.S. CL. 107). REG. 7-28-1992.
- 1,704,503. ADVAPAK. INT. CL. 4. (U.S. CL. 15). REG. 8-4-1992.
- 1,705,086. CASADEI. INT. CL. 25. (U.S. CL. 39). REG. 8-4-1992.
- 1,705,927. PURE-SET. INT. CL. 30. (U.S. CL. 46). REG. 8-4-1992.
- 1,706,084. LIVE/DEAD AND DESIGN. INT. CL. 1. (U.S. CL. 6). REG. 8-11-1992.
- 1,706,105. CVD ZINC SULFIDE. INT. CL. 1. (U.S. CLS. 1 AND 26). REG. 8-11-1992.
- 1,706,111. CRIMSON. INT. CL. 1. (U.S. CL. 6). REG. 8-11-1992.
- 1,706,473. UNIFLEX. INT. CL. 10. (U.S. CL. 44). REG. 8-11-1992.
- 1,707,085. LONE STAR AND DESIGN. INT. CL. 31. (U.S. CL. 46). REG. 8-11-1992.
- 1,708,063. ATLS. INT. CL. 16. (U.S. CL. 38). REG. 8-18-1992.
- 1,708,418. HARLEY-DAVIDSON. INT. CL. 28. (U.S. CLS. 2 AND 22). REG. 8-18-1992.
- 1,708,501. RONNOCO (STYLIZED). INT. CL. 30. (U.S. CL. 46). REG. 8-18-1992.
- 1,710,382. COMMUNITY BANK PARTNERSHIP BANKING. INT. CL. 36. (U.S. CL. 102). REG. 8-25-1992.
- 1,711,082. THERMASEAL. INT. CL. 5. (U.S. CLS. 18 AND 44). REG. 9-1-1992.
- 1,713,656. BENTOSEAL. INT. CL. 17. (U.S. CL. 12). REG. 9-8-1992.
- 1,713,661. MS-2. INT. CL. 17. (U.S. CL. 1). REG. 9-8-1992.
- 1,714,012. TORANI. INT. CLS. 32 AND 33. (U.S. CLS. 45 AND 49). REG. 9-8-1992.
- 1,715,054. E-P PLUS. INT. CL. 7. (U.S. CL. 23). REG. 9-15-1992.
- 1,715,875. COOLGUARD. INT. CL. 24. (U.S. CL. 42). REG. 9-15-1992.
- 1,716,081. TEP TIP. INT. CL. 29. (U.S. CL. 46). REG. 9-15-1992.
- 1,716,556. KELOLAND. INT. CL. 38. (U.S. CL. 104). REG. 9-15-1992.
- 1,717,835. MYOBOCK. INT. CL. 10. (U.S. CL. 44). REG. 9-22-1992.
- 1,718,810. KELO. INT. CL. 38. (U.S. CL. 104). REG. 9-22-1992.
- 1,718,825. TEXAS MOVING CO.. INT. CL. 39. (U.S. CL. 105). REG. 9-22-1992.
- 1,720,281. VARI-CRIMP. INT. CL. 17. (U.S. CL. 23). REG. 9-29-1992.
- 1,720,917. PROFORMANCE. INT. CL. 42. (U.S. CL. 101). REG. 9-29-1992.
- 1,721,286. CHEM MAX. INT. CL. 3. (U.S. CL. 52). REG. 10-6-1992.
- 1,725,054. GRIP-CRIMP. INT. CL. 7. (U.S. CL. 23). REG. 10-20-1992.
- 1,726,974. TROPICAL MIST. INT. CL. 5. (U.S. CL. 6). REG. 10-27-1992.
- 1,727,069. POWERSHOT. INT. CL. 7. (U.S. CL. 23). REG. 10-27-1992.
- 1,727,378. SAF-T-DUCT. INT. CL. 11. (U.S. CL. 34). REG. 10-27-1992.
- 1,729,425. MONSTER EDGE. INT. CL. 22. (U.S. CL. 7). REG. 11-3-1992.
- 1,729,866. GRAND CENTRAL PARTNERSHIP AND DESIGN. INT. CLS. 37 AND 42. (U.S. CLS. 100, 101 AND 103). REG. 11-3-1992.
- 1,731,435. CHOOZ AND DESIGN. INT. CL. 31. (U.S. CL. 46). REG. 11-10-1992.
- 1,732,458. HIGHLAND TANK. INT. CL. 6. (U.S. CLS. 2, 12, 13, 14, 23, 25 AND 50). REG. 11-17-1992.
- 1,733,373. WHITE RABBIT AND DESIGN. INT. CL. 30. (U.S. CL. 46). REG. 11-17-1992.
- 1,734,024. ROOKIE READ-ABOUT. INT. CL. 16. (U.S. CL. 38). REG. 11-17-1992.
- 1,735,207. COMPETENCY MANAGEMENT INCORPORATED. INT. CL. 35. (U.S. CL. 101). REG. 11-24-1992.
- 1,735,346. ADVANCED TRAUMA LIFE SUPPORT. INT. CL. 41. (U.S. CL. 101). REG. 11-24-1992.
- 1,736,449. ADVANCED TRAUMA LIFE SUPPORT. INT. CL. 16. (U.S. CL. 38). REG. 12-1-1992.
- 1,736,835. INFERNO WINGS. INT. CL. 29. (U.S. CL. 46). REG. 12-1-1992.
- 1,736,864. EL PATO AND DESIGN. INT. CL. 30. (U.S. CL. 46). REG. 12-1-1992.
- 1,737,869. NOVATHANE. INT. CL. 1. (U.S. CL. 6). REG. 12-8-1992.
- 1,738,120. SECRETAGENT (STYLIZED). INT. CL. 9. (U.S. CL. 38). REG. 12-8-1992.
- 1,738,429. DIVOTS. INT. CL. 25. (U.S. CL. 39). REG. 12-8-1992.
- 1,738,453. MISCELLANEOUS DESIGN. INT. CL. 28. (U.S. CL. 22). REG. 12-8-1992.
- 1,738,572. MAURO ARMELLINI. INT. CL. 34. (U.S. CL. 8). REG. 12-8-1992.
- 1,739,407. BIOTENE. INT. CL. 5. (U.S. CLS. 18 AND 52). REG. 12-15-1992.
- 1,739,639. CURLEX. INT. CLS. 19 AND 22 ONLY. (U.S. CLS. 1, 12 AND 42). REG. 12-15-1992.
- 1,739,682. SERIES 60. INT. CL. 12. (U.S. CL. 19). REG. 12-15-1992.
- 1,739,892. SURETOUCH. INT. CL. 21. (U.S. CLS. 2 AND 23). REG. 12-15-1992.
- 1,741,025. CHIP CHAT CAWTHON SOFTWARE AND DESIGN. INT. CL. 9. (U.S. CL. 38). REG. 12-22-1992.
- 1,741,388. DETROIT RED WINGS. INT. CL. 25. (U.S. CLS. 22 AND 39). REG. 12-22-1992.
- 1,741,669. GOOD NEIGHBOR PROGRAM. INT. CL. 36. (U.S. CL. 102). REG. 12-22-1992.
- 1,745,476. NUTRIZED (STYLIZED). INT. CL. 5. (U.S. CL. 18). REG. 1-12-1993.
- 1,746,187. L.A. REYNOLDS GARDEN SHOWCASE. INT. CL. 42. (U.S. CL. 101). REG. 1-12-1993.
- 1,748,672. RETURN PLEASE RINSE & RETURN ROYAL CREST INC. ARISTOCRAT OF MILKS REUSE REUSE: AND DESIGN. INT. CL. 29. (U.S. CL. 46). REG. 1-26-1993.
- 1,749,082. QUALITY FOOD CENTERS (STYLIZED). INT. CL. 42. (U.S. CL. 101). REG. 1-26-1993.

- 1,753,088. KTS. INT. CL. 1. (U.S. CLS. 6 AND 10). REG. 2-16-1993.
- 2,428,095. VIEWTOUCH. INT. CLS. 9, 35 AND 42. (U.S. CLS. 21, 23, 26, 36, 38, 100, 101 AND 102). REG. 2-13-2001.
- 2,460,082. MXSITE. INT. CL. 1. (U.S. CLS. 1, 5, 6, 10, 26 AND 46). REG. 6-12-2001.
- 2,460,882. VOICE OF THE HIMALAYAS. INT. CL. 41. (U.S. CLS. 100, 101 AND 107). REG. 6-19-2001.
- 2,460,936. COGNIDYNE. INT. CLS. 9 AND 42 ONLY. (U.S. CLS. 21, 23, 26, 36, 38, 100 AND 101). REG. 6-19-2001.
- 2,462,098. MISCELLANEOUS DESIGN. INT. CL. 6. (U.S. CLS. 2, 12, 13, 14, 23, 25 AND 50). REG. 6-19-2001.
- 2,463,224. LAA-LAA. INT. CL. 28. (U.S. CLS. 22, 23, 38 AND 50). REG. 6-26-2001.
- 2,464,096. SECURSIGN. INT. CL. 9. (U.S. CLS. 21, 23, 26, 36 AND 38). REG. 6-26-2001.
- 2,464,407. PIAGET ALTIPLANO. INT. CL. 14. (U.S. CLS. 2, 27, 28 AND 50). REG. 6-26-2001.
- 2,464,479. PYROEDGE. INT. CL. 19. (U.S. CLS. 1, 12, 33 AND 50). REG. 6-26-2001.
- 2,464,572. BXS. INT. CL. 28. (U.S. CLS. 22, 23, 38 AND 50). REG. 6-26-2001.
- 2,464,765. GROM (STYLIZED). INT. CL. 25. (U.S. CLS. 22 AND 39). REG. 7-3-2001.
- 2,464,778. CALE (STYLIZED). INT. CL. 25. (U.S. CLS. 22 AND 39). REG. 7-3-2001.
- 2,465,573. BIOBRIDGE. INT. CL. 10. (U.S. CLS. 26, 39 AND 44). REG. 7-3-2001.
- 2,465,574. BIOONLAY. INT. CL. 10. (U.S. CLS. 26, 39 AND 44). REG. 7-3-2001.
- 2,465,575. BIOINLAY. INT. CL. 10. (U.S. CLS. 26, 39 AND 44). REG. 7-3-2001.
- 2,465,988. S AND DESIGN. INT. CLS. 6 AND 12. (U.S. CLS. 2, 12, 13, 14, 19, 21, 23, 25, 31, 35, 44 AND 50). REG. 7-3-2001.
- 2,466,330. COME JOIN ... THE HUMAN RACE. INT. CL. 41. (U.S. CLS. 100, 101 AND 107). REG. 7-3-2001.
- 2,467,572. MILLEX. INT. CL. 9. (U.S. CLS. 21, 23, 26, 36 AND 38). REG. 7-10-2001.
- 2,468,822. WROX PROGRAMMER TO PROGRAMMER AND DESIGN. INT. CL. 16. (U.S. CLS. 2, 5, 22, 23, 29, 37, 38 AND 50). REG. 7-17-2001.
- 2,473,178. INDEXOR. INT. CL. 36. (U.S. CLS. 100, 101 AND 102). REG. 7-31-2001.
- 2,480,026. "YOUR AVENUE TO GREATER REVENUE". INT. CL. 35. (U.S. CLS. 100, 101 AND 102). REG. 8-21-2001.
- 2,481,617. PAYSUITE. INT. CL. 9. (U.S. CLS. 21, 23, 26, 36 AND 38). REG. 8-28-2001.
- 2,481,879. MOFO. INT. CL. 42. (U.S. CLS. 100 AND 101). REG. 8-28-2001.
- 2,483,380. KORATO. INT. CL. 20. (U.S. CLS. 2, 13, 22, 25, 32 AND 50). REG. 8-28-2001.
- 2,483,486. MODERN LIVING. INT. CL. 24 ONLY. (U.S. CLS. 42 AND 50). REG. 8-28-2001.
- 2,487,558. NSTA PRESS. INT. CLS. 9 AND 16. (U.S. CLS. 2, 5, 21, 22, 23, 26, 29, 36, 37, 38 AND 50). REG. 9-11-2001.
- 2,488,683. BIOCOMPARE. INT. CL. 42. (U.S. CLS. 100 AND 101). REG. 9-11-2001.
- 2,491,084. SIMPLICITY. INT. CL. 11. (U.S. CLS. 13, 21, 23, 31 AND 34). REG. 9-18-2001.
- 2,491,924. SDS SUPER DIMENSION-70 AND DESIGN. INT. CL. 9. (U.S. CLS. 21, 23, 26, 36 AND 38). REG. 9-25-2001.
- 2,492,863. TRAPROUTE. INT. CL. 9. (U.S. CLS. 21, 23, 26, 36 AND 38). REG. 9-25-2001.
- 2,500,699. CHA CHAS. INT. CL. 15. (U.S. CLS. 2, 21 AND 36). REG. 10-23-2001.
- 2,501,549. SUTHERLANDS EXPRESS. INT. CL. 35. (U.S. CLS. 100, 101 AND 102). REG. 10-30-2001.
- 2,502,846. BURCAN (STYLIZED). INT. CL. 5. (U.S. CLS. 6, 18, 44, 46, 51 AND 52). REG. 10-30-2001.
- 2,504,288. MISCELLANEOUS DESIGN. INT. CL. 3. (U.S. CLS. 1, 4, 6, 50, 51 AND 52). REG. 11-6-2001.
- 2,504,475. TURNAROUND MANAGEMENT ASSOCIATION. INT. CL. 42. (U.S. CLS. 100 AND 101). REG. 11-6-2001.
- 2,506,612. MISCELLANEOUS DESIGN. INT. CL. 3. (U.S. CLS. 1, 4, 6, 50, 51 AND 52). REG. 11-13-2001.
- 2,507,413. MISCELLANEOUS DESIGN. INT. CL. 9. (U.S. CLS. 21, 23, 26, 36 AND 38). REG. 11-13-2001.
- 2,509,819. BRAGLET. INT. CL. 14. (U.S. CLS. 2, 27, 28 AND 50). REG. 11-20-2001.
- 2,514,412. DEGREE ° C AND DESIGN. INT. CL. 9. (U.S. CLS. 21, 23, 26, 36 AND 38). REG. 12-4-2001.
- 2,514,834. VISIONS AUTO GLASS. INT. CL. 37. (U.S. CLS. 100, 103 AND 106). REG. 12-4-2001.
- 2,514,835. PERFECTSEND. INT. CL. 35. (U.S. CLS. 100, 101 AND 102). REG. 12-4-2001.
- 2,518,346. DRIVE ONE. INT. CL. 7. (U.S. CLS. 13, 19, 21, 23, 31, 34 AND 35). REG. 12-11-2001.
- 2,518,900. BJORN BORG (STYLIZED). INT. CLS. 3, 9, 18 AND 25 ONLY. (U.S. CLS. 1, 2, 3, 4, 6, 21, 22, 23, 26, 36, 38, 39, 41, 50, 51 AND 52). REG. 12-18-2001.
- 2,518,960. ORICA. INT. CL. 40. (U.S. CLS. 100, 103 AND 106). REG. 12-18-2001.
- 2,518,990. MISCELLANEOUS DESIGN. INT. CL. 1. (U.S. CLS. 1, 5, 6, 10, 26 AND 46). REG. 12-18-2001.
- 2,518,992. MISCELLANEOUS DESIGN. INT. CL. 9. (U.S. CLS. 21, 23, 26, 36 AND 38). REG. 12-18-2001.
- 2,519,016. TAG METALS. INT. CL. 12. (U.S. CLS. 19, 21, 23, 31, 35 AND 44). REG. 12-18-2001.
- 2,519,134. TCF HOME LOANS. INT. CL. 36. (U.S. CLS. 100, 101 AND 102). REG. 12-18-2001.
- 2,519,256. HYPERLEARNING. INT. CL. 41. (U.S. CLS. 100, 101 AND 107). REG. 12-18-2001.
- 2,519,491. RAPS. INT. CLS. 16, 41 AND 42 ONLY. (U.S. CLS. 2, 5, 22, 23, 29, 37, 38, 50, 100, 101 AND 107). REG. 12-18-2001.
- 2,519,790. TEMPDOT AND DESIGN. INT. CL. 9. (U.S. CLS. 21, 23, 26, 36 AND 38). REG. 12-18-2001.
- 2,519,797. WHEELER. INT. CL. 14. (U.S. CLS. 2, 27, 28 AND 50). REG. 12-18-2001.
- 2,519,819. HOVER-DAVIS. INT. CL. 7. (U.S. CLS. 13, 19, 21, 23, 31, 34 AND 35). REG. 12-18-2001.
- 2,520,317. ACIDSOLITAIRE. INT. CL. 9. (U.S. CLS. 21, 23, 26, 36 AND 38). REG. 12-18-2001.
- 2,520,339. ZIK-ZOK. INT. CL. 14. (U.S. CLS. 2, 27, 28 AND 50). REG. 12-18-2001.
- 2,520,727. ELMWOOD COMPANY. INT. CLS. 35 AND 37. (U.S. CLS. 100, 101, 102, 103 AND 106). REG. 12-18-2001.
- 2,520,852. VIROSEQ. INT. CL. 9. (U.S. CLS. 21, 23, 26, 36 AND 38). REG. 12-18-2001.
- 2,520,925. SHEER-LINES. INT. CL. 26. (U.S. CLS. 37, 39, 40, 42 AND 50). REG. 12-18-2001.
- 2,521,474. ORICA. INT. CL. 13. (U.S. CLS. 2 AND 9). REG. 12-25-2001.
- 2,521,724. TV GLOBO INTERNACIONAL AND DESIGN. INT. CLS. 38, 41 AND 42. (U.S. CLS. 100, 101, 104 AND 107). REG. 12-25-2001.
- 2,521,838. VARA KAMIN'S IMPRESSIONS OF LIGHT. INT. CL. 11. (U.S. CLS. 13, 21, 23, 31 AND 34). REG. 12-25-2001.
- 2,522,074. RENEWING MINDS TRANSFORMING LIVES. INT. CL. 35. (U.S. CLS. 100, 101 AND 102). REG. 12-25-2001.
- 2,522,172. JAMIE LYNN. INT. CLS. 4, 8, 16, 18, 20 AND 21. (U.S. CLS. 1, 2, 3, 5, 6, 13, 15, 22, 23, 25, 28, 29, 30, 32, 33, 37, 38, 40, 41, 44 AND 50). REG. 12-25-2001.
- 2,522,299. CURIOUS EMPORIUM. INT. CL. 35. (U.S. CLS. 100, 101 AND 102). REG. 12-25-2001.
- 2,522,325. CON-DEK. INT. CL. 37. (U.S. CLS. 100, 103 AND 106). REG. 12-25-2001.
- 2,522,415. SAMMIE SAYS YOU OTTER SAVE AND DESIGN. INT. CL. 36. (U.S. CLS. 100, 101 AND 102). REG. 12-25-2001.
- 2,522,561. CUDDLY CLASSICS. INT. CL. 28. (U.S. CLS. 22, 23, 38 AND 50). REG. 12-25-2001.
- 2,522,633. MYGULFSTREAM.COM. INT. CL. 37. (U.S. CLS. 100, 103 AND 106). REG. 12-25-2001.
- 2,522,676. MISCELLANEOUS DESIGN. INT. CLS. 35, 37, 41 AND 42. (U.S. CLS. 100, 101, 102, 103, 106 AND 107). REG. 12-25-2001.
- 2,522,681. DURKAN. INT. CL. 27. (U.S. CLS. 19, 20, 37, 42 AND 50). REG. 12-25-2001.
- 2,522,861. CHEVROLET. INT. CL. 28. (U.S. CLS. 22, 23, 38 AND 50). REG. 12-25-2001.
- 2,522,920. INVANZ. INT. CL. 5. (U.S. CLS. 6, 18, 44, 46, 51 AND 52). REG. 12-25-2001.
- 2,522,922. BRAINWAVE. INT. CL. 9. (U.S. CLS. 21, 23, 26, 36 AND 38). REG. 12-25-2001.
- 2,522,957. ECOMICRON. INT. CLS. 7, 11 AND 20. (U.S. CLS. 2, 13, 19, 21, 22, 23, 25, 31, 32, 34, 35 AND 50). REG. 12-25-2001.

- 2,523,120. FILESTREAM. INT. CL. 9. (U.S. CLS. 21, 23, 26, 36 AND 38). REG. 12-25-2001.
- 2,523,157. CRANSTON CRANBERRY. INT. CLS. 28 AND 31. (U.S. CLS. 1, 22, 23, 38, 46 AND 50). REG. 12-25-2001.
- 2,523,241. WI FI AND DESIGN. U.S. CL. A. REG. 12-25-2001.
- 2,523,471. KID BEAR. INT. CL. 5. (U.S. CLS. 6, 18, 44, 46, 51 AND 52). REG. 12-25-2001.
- 2,523,794. ORICA. INT. CL. 37. (U.S. CLS. 100, 103 AND 106). REG. 1-1-2002.
- 2,523,795. ORICA. INT. CL. 9. (U.S. CLS. 21, 23, 26, 36 AND 38). REG. 1-1-2002.
- 2,523,855. PRINTDRIVE. INT. CL. 9. (U.S. CLS. 21, 23, 26, 36 AND 38). REG. 1-1-2002.
- 2,523,896. E.A.F.A. THE WATSON SIMULATOR AND DESIGN. INT. CL. 9. (U.S. CLS. 21, 23, 26, 36 AND 38). REG. 1-1-2002.
- 2,523,953. SPECSEARCH. INT. CL. 35. (U.S. CLS. 100, 101 AND 102). REG. 1-1-2002.
- 2,523,975. ECODIS. INT. CL. 1. (U.S. CLS. 1, 5, 6, 10, 26 AND 46). REG. 1-1-2002.
- 2,523,995. DOG AGILITY STEEPLECHASE. INT. CL. 41. (U.S. CLS. 100, 101 AND 107). REG. 1-1-2002.
- 2,524,017. CASH MONEY RECORDS. INT. CLS. 35 AND 41. (U.S. CLS. 100, 101, 102 AND 107). REG. 1-1-2002.
- 2,524,056. INNOVATIVE QUALITY IN HIGH PERFORMANCE PLASTICS. INT. CL. 40. (U.S. CLS. 100, 103 AND 106). REG. 1-1-2002.
- 2,524,102. PRISE. INT. CL. 36. (U.S. CLS. 100, 101 AND 102). REG. 1-1-2002.
- 2,524,225. GPT. INT. CL. 9. (U.S. CLS. 21, 23, 26, 36 AND 38). REG. 1-1-2002.
- 2,524,241. SUPER SPERM AND DESIGN. INT. CL. 42. (U.S. CLS. 100 AND 101). REG. 1-1-2002.
- 2,524,287. KEMAH BOARDWALK AND DESIGN. INT. CL. 25. (U.S. CLS. 22 AND 39). REG. 1-1-2002.
- 2,524,345. U.S. ARMY JROTC AND DESIGN. U.S. CL. 200. REG. 1-1-2002.
- 2,524,535. PRINCETON FARMS AND DESIGN. INT. CL. 35. (U.S. CLS. 100, 101 AND 102). REG. 1-1-2002.
- 2,524,700. MISCELLANEOUS DESIGN. INT. CL. 9. (U.S. CLS. 21, 23, 26, 36 AND 38). REG. 1-1-2002.
- 2,524,808. WHITELIGHT DESIGN. INT. CL. 42. (U.S. CLS. 100 AND 101). REG. 1-1-2002.
- 2,524,828. SERUM DE LA MER. INT. CL. 3. (U.S. CLS. 1, 4, 6, 50, 51 AND 52). REG. 1-1-2002.
- 2,524,829. NETTOYANT DE LA MER. INT. CL. 3. (U.S. CLS. 1, 4, 6, 50, 51 AND 52). REG. 1-1-2002.
- 2,524,876. VITATRESS AND DESIGN. INT. CLS. 3 AND 5. (U.S. CLS. 1, 4, 6, 18, 44, 46, 50, 51 AND 52). REG. 1-1-2002.
- 2,524,925. MIDDLE MOUNTAIN MUSIC. INT. CL. 9. (U.S. CLS. 21, 23, 26, 36 AND 38). REG. 1-1-2002.
- 2,524,948. SHARPER CARDS. INT. CL. 16. (U.S. CLS. 2, 5, 22, 23, 29, 37, 38 AND 50). REG. 1-1-2002.
- 2,524,949. MPISPY. INT. CL. 9. (U.S. CLS. 21, 23, 26, 36 AND 38). REG. 1-1-2002.
- 2,524,993. TORCA AND DESIGN. INT. CL. 12. (U.S. CLS. 19, 21, 23, 31, 35 AND 44). REG. 1-1-2002.
- 2,525,133. METROCAST. INT. CL. 9. (U.S. CLS. 21, 23, 26, 36 AND 38). REG. 1-1-2002.
- 2,525,210. MISCELLANEOUS DESIGN. INT. CL. 37. (U.S. CLS. 100, 103 AND 106). REG. 1-1-2002.
- 2,525,310. SIMPLICITY. INT. CL. 5. (U.S. CLS. 6, 18, 44, 46, 51 AND 52). REG. 1-1-2002.
- 2,525,313. I AM AN ATHLETE. INT. CL. 41. (U.S. CLS. 100, 101 AND 107). REG. 1-1-2002.
- 2,525,416. SOULSCOPE. INT. CLS. 16 AND 42 ONLY. (U.S. CLS. 2, 5, 22, 23, 29, 37, 38, 50, 100 AND 101). REG. 1-1-2002.
- 2,525,429. ROYAL SKATEBOARD TRUCK COMPANY. INT. CLS. 18, 25 AND 28. (U.S. CLS. 1, 2, 3, 22, 23, 38, 39, 41 AND 50). REG. 1-1-2002.
- 2,525,480. PICK ONE 21. INT. CL. 41. (U.S. CLS. 100, 101 AND 107). REG. 1-1-2002.
- 2,525,502. PHASEFLEX. INT. CL. 9. (U.S. CLS. 21, 23, 26, 36 AND 38). REG. 1-1-2002.
- 2,525,614. PS. INT. CL. 36. (U.S. CLS. 100, 101 AND 102). REG. 1-1-2002.
- 2,525,632. LIFE AS A BLACKMAN THE GAME. INT. CL. 28. (U.S. CLS. 22, 23, 38 AND 50). REG. 1-1-2002.
- 2,525,652. ARCSOFT PHOTOMONTAGE. INT. CL. 9. (U.S. CLS. 21, 23, 26, 36 AND 38). REG. 1-1-2002.
- 2,525,699. MASTERDUCT. INT. CLS. 17 AND 19. (U.S. CLS. 1, 5, 12, 13, 33, 35 AND 50). REG. 1-1-2002.
- 2,525,702. FALL PROOF. INT. CL. 25. (U.S. CLS. 22 AND 39). REG. 1-1-2002.
- 2,525,716. SERELISA. INT. CL. 5. (U.S. CLS. 6, 18, 44, 46, 51 AND 52). REG. 1-1-2002.
- 2,525,765. INVESTING FOR FIREFIGHTERS AND THEIR FAMILIES AND DESIGN. INT. CL. 36. (U.S. CLS. 100, 101 AND 102). REG. 1-1-2002.
- 2,525,771. STARWOOD PREFERRED PLANNER. INT. CL. 35. (U.S. CLS. 100, 101 AND 102). REG. 1-1-2002.
- 2,525,795. WI-FI. U.S. CL. A. REG. 1-1-2002.
- 2,525,865. ANAVISTA. INT. CL. 41. (U.S. CLS. 100, 101 AND 107). REG. 1-1-2002.
- 2,525,975. 4MYACCOUNT!. INT. CL. 36. (U.S. CLS. 100, 101 AND 102). REG. 1-1-2002.
- 2,525,978. PACIFIC MERCHANTS. INT. CLS. 3, 25 AND 35. (U.S. CLS. 1, 4, 6, 22, 39, 50, 51, 52, 100, 101 AND 102). REG. 1-1-2002.
- 2,525,984. STACK & VAC STANDARD CHARACTER MARK. INT. CL. 22. (U.S. CLS. 1, 2, 7, 19, 22, 42 AND 50). REG. 1-1-2002.
- 2,526,194. E-DISK. INT. CL. 9. (U.S. CLS. 21, 23, 26, 36 AND 38). REG. 1-1-2002.
- 2,526,201. ADOPT-A-CAT MONTH. INT. CL. 42. (U.S. CLS. 100 AND 101). REG. 1-1-2002.
- 2,526,304. COLORLOG. INT. CL. 4. (U.S. CLS. 1, 6 AND 15). REG. 1-1-2002.
- 2,526,305. THE BROADWAY JUNIOR COLLECTION AND DESIGN. INT. CL. 41 ONLY. (U.S. CLS. 100, 101 AND 107). REG. 1-1-2002.
- 2,526,437. ROHRFLEX. INT. CLS. 6 AND 9. (U.S. CLS. 2, 12, 13, 14, 21, 23, 25, 26, 36, 38 AND 50). REG. 1-8-2002.
- 2,526,446. ADMIRAL AND DESIGN. INT. CL. 12. (U.S. CLS. 19, 21, 23, 31, 35 AND 44). REG. 1-8-2002.
- 2,526,524. GLOVEPLUS. INT. CL. 10. (U.S. CLS. 26, 39 AND 44). REG. 1-8-2002.
- 2,526,533. DENTI-ROO AND DESIGN. INT. CL. 5. (U.S. CLS. 6, 18, 44, 46, 51 AND 52). REG. 1-8-2002.
- 2,526,607. ARES SPORTSWEAR. INT. CLS. 40 AND 42. (U.S. CLS. 100, 101, 103 AND 106). REG. 1-8-2002.
- 2,526,612. HUMBERTO CANALE. INT. CL. 33. (U.S. CLS. 47 AND 49). REG. 1-8-2002.
- 2,527,155. Q.F.T. INT. CL. 42. (U.S. CLS. 100 AND 101). REG. 1-8-2002.
- 2,527,161. IBIBLIO. INT. CL. 41. (U.S. CLS. 100, 101 AND 107). REG. 1-8-2002.
- 2,527,251. LADYBUG. INT. CL. 16. (U.S. CLS. 2, 5, 22, 23, 29, 37, 38 AND 50). REG. 1-8-2002.
- 2,527,282. PROJECT MANAGEMENT BOOTCAMP STANDARD CHARACTER MARK. INT. CL. 41. (U.S. CLS. 100, 101 AND 107). REG. 1-8-2002.
- 2,527,344. QUINTUPLE ROPE. INT. CL. 14. (U.S. CLS. 2, 27, 28 AND 50). REG. 1-8-2002.
- 2,527,422. CDW G AND DESIGN. INT. CL. 35. (U.S. CLS. 100, 101 AND 102). REG. 1-8-2002.
- 2,527,438. NA-QUIKLINK. INT. CL. 42. (U.S. CLS. 100 AND 101). REG. 1-8-2002.
- 2,527,472. MISCELLANEOUS DESIGN. INT. CLS. 25, 28, 36 AND 41. (U.S. CLS. 22, 23, 38, 39, 50, 100, 101, 102 AND 107). REG. 1-8-2002.
- 2,527,519. B-H. INT. CL. 6. (U.S. CLS. 2, 12, 13, 14, 23, 25 AND 50). REG. 1-8-2002.
- 2,527,520. GRANDWAY. INT. CL. 36. (U.S. CLS. 100, 101 AND 102). REG. 1-8-2002.
- 2,527,584. FREIGHTWORLD.COM. INT. CL. 35. (U.S. CLS. 100, 101 AND 102). REG. 1-8-2002.
- 2,527,589. S.COM. INT. CL. 42. (U.S. CLS. 100 AND 101). REG. 1-8-2002.
- 2,527,660. STEVE'S PRINCE OF STEAKS. INT. CL. 42. (U.S. CLS. 100 AND 101). REG. 1-8-2002.
- 2,527,781. PAVE GRO STANDARD CHARACTER MARK. INT. CL. 19. (U.S. CLS. 1, 12, 33 AND 50). REG. 1-8-2002.
- 2,527,784. ASQUITH & SOMERSET. INT. CL. 3. (U.S. CLS. 1, 4, 6, 50, 51 AND 52). REG. 1-8-2002.
- 2,527,882. HERDER. INT. CL. 41. (U.S. CLS. 100, 101 AND 107). REG. 1-8-2002.
- 2,528,025. FORECAST ARCHITECT. INT. CL. 9. (U.S. CLS. 21, 23, 26, 36 AND 38). REG. 1-8-2002.
- 2,528,258. SENETTI. INT. CL. 31. (U.S. CLS. 1 AND 46). REG. 1-8-2002.
- 2,528,385. MISCELLANEOUS DESIGN. INT. CL. 29. (U.S. CL. 46). REG. 1-8-2002.
- 2,528,476. FIESTA GARDEN. INT. CL. 29. (U.S. CL. 46). REG. 1-8-2002.

- 2,528,506. ARTURO FUENTE. INT. CL. 25. (U.S. CLS. 22 AND 39). REG. 1-8-2002.
- 2,528,582. LINOSAFE. INT. CL. 3. (U.S. CLS. 1, 4, 6, 50, 51 AND 52). REG. 1-8-2002.
- 2,528,657. PRULIFE UNIVERSAL. INT. CL. 36. (U.S. CLS. 100, 101 AND 102). REG. 1-8-2002.
- 2,528,843. MLRS. INT. CL. 13. (U.S. CLS. 2 AND 9). REG. 1-15-2002.
- 2,528,870. PASSPORT TO HEALTH MEMORIAL HOSPITAL AND DESIGN. INT. CL. 16. (U.S. CLS. 2, 5, 22, 23, 29, 37, 38 AND 50). REG. 1-15-2002.
- 2,528,939. AETNAGROUP (STYLIZED). INT. CL. 7. (U.S. CLS. 13, 19, 21, 23, 31, 34 AND 35). REG. 1-15-2002.
- 2,528,987. PHANTOM. INT. CL. 9. (U.S. CLS. 21, 23, 26, 36 AND 38). REG. 1-15-2002.
- 2,529,016. NAAHR NATIONAL ASSOCIATION OF AFRICAN AMERICANS IN HUMAN RESOURCES AND DESIGN. INT. CL. 42. (U.S. CLS. 100 AND 101). REG. 1-15-2002.
- 2,529,166. ISO-TEK. INT. CL. 11. (U.S. CLS. 13, 21, 23, 31 AND 34). REG. 1-15-2002.
- 2,529,227. KEVA MARIE. INT. CL. 42. (U.S. CLS. 100 AND 101). REG. 1-15-2002.
- 2,529,252. SURE FLAME. INT. CL. 11. (U.S. CLS. 13, 21, 23, 31 AND 34). REG. 1-15-2002.
- 2,529,265. DAMNYANKEE. COM AND DESIGN. INT. CL. 41. (U.S. CLS. 100, 101 AND 107). REG. 1-15-2002.
- 2,529,547. MV. INT. CL. 9. (U.S. CLS. 21, 23, 26, 36 AND 38). REG. 1-15-2002.
- 2,529,684. KARRAN (STYLIZED). INT. CL. 11. (U.S. CLS. 13, 21, 23, 31 AND 34). REG. 1-15-2002.
- 2,529,687. DEVIL DUCKIE. INT. CL. 28. (U.S. CLS. 22, 23, 38 AND 50). REG. 1-15-2002.
- 2,529,913. SHOWER-DRI. INT. CL. 10. (U.S. CLS. 26, 39 AND 44). REG. 1-15-2002.
- 2,529,987. PARTSPERKS. INT. CL. 35. (U.S. CLS. 100, 101 AND 102). REG. 1-15-2002.
- 2,530,017. CAPIENT. INT. CL. 42. (U.S. CLS. 100 AND 101). REG. 1-15-2002.
- 2,530,140. SUPPORTONE. INT. CL. 42. (U.S. CLS. 100 AND 101). REG. 1-15-2002.
- 2,530,291. SPLENDID PRODUCTS AND DESIGN. INT. CL. 31. (U.S. CLS. 1 AND 46). REG. 1-15-2002.
- 2,530,496. MINETECH. INT. CLS. 9 AND 42. (U.S. CLS. 21, 23, 26, 36, 38, 100 AND 101). REG. 1-15-2002.
- 2,530,498. MINETECH DATA MINING SOLUTIONS AND DESIGN. INT. CLS. 9 AND 42. (U.S. CLS. 21, 23, 26, 36, 38, 100 AND 101). REG. 1-15-2002.
- 2,530,501. SCHWAB PORTFOLIO CHECKUP. INT. CL. 36. (U.S. CLS. 100, 101 AND 102). REG. 1-15-2002.
- 2,530,517. SCRIP WORLD. INT. CL. 36. (U.S. CLS. 100, 101 AND 102). REG. 1-15-2002.
- 2,530,682. REVERCEL. INT. CL. 3. (U.S. CLS. 1, 4, 6, 50, 51 AND 52). REG. 1-15-2002.
- 2,530,720. PPR. INT. CL. 9. (U.S. CLS. 21, 23, 26, 36 AND 38). REG. 1-15-2002.
- 2,531,026. AMATEUR RADIO EMERGENCY SERVICE. INT. CL. 42. (U.S. CLS. 100 AND 101). REG. 1-15-2002.
- 2,531,228. LARK AND DESIGN. INT. CL. 34. (U.S. CLS. 2, 8, 9 AND 17). REG. 1-22-2002.
- 2,531,318. DIALAC. INT. CL. 1. (U.S. CLS. 1, 5, 6, 10, 26 AND 46). REG. 1-22-2002.
- 2,531,417. CITRA-SOLV. INT. CL. 3. (U.S. CLS. 1, 4, 6, 50, 51 AND 52). REG. 1-22-2002.
- 2,531,723. KENTON TODAY. INT. CL. 41. (U.S. CLS. 100, 101 AND 107). REG. 1-22-2002.
- 2,531,847. SLICK SET. INT. CL. 10. (U.S. CLS. 26, 39 AND 44). REG. 1-22-2002.
- 2,532,616. AB DOLLY. INT. CL. 28. (U.S. CLS. 22, 23, 38 AND 50). REG. 1-22-2002.
- 2,533,147. ON-LINE (STYLIZED). INT. CL. 31. (U.S. CLS. 1 AND 46). REG. 1-22-2002.
- 2,533,535. THE TOTAL DIVING SYSTEM. INT. CL. 41. (U.S. CLS. 100, 101 AND 107). REG. 1-29-2002.
- 2,533,607. QPAK. INT. CL. 9. (U.S. CLS. 21, 23, 26, 36 AND 38). REG. 1-29-2002.
- 2,533,705. DUST FREE. INT. CL. 2. (U.S. CLS. 6, 11 AND 16). REG. 1-29-2002.
- 2,534,210. VOLCOM. INT. CL. 25. (U.S. CLS. 22 AND 39). REG. 1-29-2002.
- 2,534,421. MISCELLANEOUS DESIGN. INT. CLS. 12 AND 42. (U.S. CLS. 19, 21, 23, 31, 35, 44, 100 AND 101). REG. 1-29-2002.
- 2,534,599. EVOLUTION. INT. CL. 7. (U.S. CLS. 13, 19, 21, 23, 31, 34 AND 35). REG. 1-29-2002.
- 2,534,959. CORRIGO. INT. CL. 42. (U.S. CLS. 100 AND 101). REG. 1-29-2002.
- 2,534,977. SOHO DEPOT. INT. CL. 35. (U.S. CLS. 100, 101 AND 102). REG. 1-29-2002.
- 2,535,239. SANI-CLOR. INT. CL. 1. (U.S. CLS. 1, 5, 6, 10, 26 AND 46). REG. 2-5-2002.
- 2,535,500. DAHLAR. INT. CL. 17. (U.S. CLS. 1, 5, 12, 13, 35 AND 50). REG. 2-5-2002.
- 2,535,714. S AND DESIGN. INT. CL. 30. (U.S. CL. 46). REG. 2-5-2002.
- 2,535,919. BAKER 500. INT. CL. 36. (U.S. CLS. 100, 101 AND 102). REG. 2-5-2002.
- 2,536,081. C (STYLIZED). INT. CL. 25. (U.S. CLS. 22 AND 39). REG. 2-5-2002.
- 2,536,136. FISHING HAS NO BOUNDARIES. INT. CL. 41. (U.S. CLS. 100, 101 AND 107). REG. 2-5-2002.
- 2,536,143. SPANISH ONIONS IDAHO EASTERN OREGON AND DESIGN. INT. CL. 31. (U.S. CLS. 1 AND 46). REG. 2-5-2002.
- 2,536,426. ZIPSALES. INT. CL. 9. (U.S. CLS. 21, 23, 26, 36 AND 38). REG. 2-5-2002.
- 2,536,427. ZIPCOMM. INT. CL. 9. (U.S. CLS. 21, 23, 26, 36 AND 38). REG. 2-5-2002.
- 2,536,428. ZIPUTIL. INT. CL. 9. (U.S. CLS. 21, 23, 26, 36 AND 38). REG. 2-5-2002.
- 2,536,629. SEYMOUR. INT. CL. 8. (U.S. CLS. 23, 28 AND 44). REG. 2-5-2002.
- 2,536,671. RUG DOCTOR. INT. CL. 37. (U.S. CLS. 100, 103 AND 106). REG. 2-5-2002.
- 2,536,708. GREAT PLACE TO WORK AND DESIGN. INT. CL. 35. (U.S. CLS. 100, 101 AND 102). REG. 2-5-2002.
- 2,536,716. LS-40. INT. CL. 19. (U.S. CLS. 1, 12, 33 AND 50). REG. 2-5-2002.
- 2,536,792. MINRO-SIL 2001. INT. CL. 19. (U.S. CLS. 1, 12, 33 AND 50). REG. 2-5-2002.
- 2,537,142. GRAB-SAFE. INT. CL. 6. (U.S. CLS. 2, 12, 13, 14, 23, 25 AND 50). REG. 2-5-2002.
- 2,537,308. WHERE THE WORLD PLAYS BINGO. INT. CLS. 9 AND 41. (U.S. CLS. 21, 23, 26, 36, 38, 100, 101 AND 107). REG. 2-5-2002.
- 2,537,378. PART SERVER. INT. CL. 9. (U.S. CLS. 21, 23, 26, 36 AND 38). REG. 2-5-2002.
- 2,537,581. SANICHEM. INT. CL. 5. (U.S. CLS. 6, 18, 44, 46, 51 AND 52). REG. 2-12-2002.
- 2,537,725. S AND DESIGN. INT. CL. 36. (U.S. CLS. 100, 101 AND 102). REG. 2-12-2002.
- 2,537,828. DRI. INT. CL. 1. (U.S. CLS. 1, 5, 6, 10, 26 AND 46). REG. 2-12-2002.
- 2,538,327. SUPER SUCKER. INT. CL. 7. (U.S. CLS. 13, 19, 21, 23, 31, 34 AND 35). REG. 2-12-2002.
- 2,538,356. AIRPAK. INT. CL. 11. (U.S. CLS. 13, 21, 23, 31 AND 34). REG. 2-12-2002.
- 2,538,370. ATOPICA. INT. CL. 5. (U.S. CLS. 6, 18, 44, 46, 51 AND 52). REG. 2-12-2002.
- 2,538,565. CHROME HEARTS AND DESIGN. INT. CL. 9. (U.S. CLS. 21, 23, 26, 36 AND 38). REG. 2-12-2002.
- 2,538,750. PAUL REVERE SILVERSMITHS. INT. CLS. 14 AND 20 ONLY. (U.S. CLS. 2, 13, 22, 25, 27, 28, 32 AND 50). REG. 2-19-2002.
- 2,538,784. TIDAL ENERGY MARKETING. INT. CLS. 36 AND 39. (U.S. CLS. 100, 101, 102 AND 105). REG. 2-19-2002.
- 2,538,817. DURR. INT. CLS. 7, 11 AND 42. (U.S. CLS. 13, 19, 21, 23, 31, 34, 35, 100 AND 101). REG. 2-19-2002.
- 2,538,825. UVC EMITTER. INT. CL. 11. (U.S. CLS. 13, 21, 23, 31 AND 34). REG. 2-19-2002.
- 2,538,865. PROFESSOR PINEAPPLE. INT. CL. 31. (U.S. CLS. 1 AND 46). REG. 2-19-2002.
- 2,538,884. CENTER FOR CHANGE AND DESIGN. INT. CL. 42. (U.S. CLS. 100 AND 101). REG. 2-19-2002.
- 2,538,941. ES. INT. CLS. 9 AND 35 ONLY. (U.S. CLS. 21, 23, 26, 36, 38, 100, 101 AND 102). REG. 2-19-2002.
- 2,538,957. EAST WEST CONNECTION. INT. CLS. 41 AND 42. (U.S. CLS. 100, 101 AND 107). REG. 2-19-2002.
- 2,538,959. ALTA VIA CONSULTING, LLC "A BETER USE OF INFORMATION" AND DESIGN. INT. CLS. 35, 41 AND 42. (U.S. CLS. 100, 101, 102 AND 107). REG. 2-19-2002.
- 2,539,058. HOT & CRUSTY. INT. CLS. 35 AND 42. (U.S. CLS. 100, 101 AND 102). REG. 2-19-2002.
- 2,539,065. ROBERTO CAVALLI (STYLIZED). INT. CL. 18. (U.S. CLS. 1, 2, 3, 22 AND 41). REG. 2-19-2002.

- 2,539,150. W WALONG AND DESIGN. INT. CL. 35. (U.S. CLS. 100, 101 AND 102). REG. 2-19-2002.
- 2,539,195. FLAVORX (STYLIZED). INT. CL. 42. (U.S. CLS. 100 AND 101). REG. 2-19-2002.
- 2,539,263. MLRS. INT. CL. 28. (U.S. CLS. 22, 23, 38 AND 50). REG. 2-19-2002.
- 2,539,354. ESTECH. INT. CL. 10. (U.S. CLS. 26, 39 AND 44). REG. 2-19-2002.
- 2,539,371. IF AND DESIGN. INT. CL. 24 ONLY. (U.S. CLS. 42 AND 50). REG. 2-19-2002.
- 2,539,531. GURU. INT. CL. 12. (U.S. CLS. 19, 21, 23, 31, 35 AND 44). REG. 2-19-2002.
- 2,539,691. AMINONIR. INT. CL. 42. (U.S. CLS. 100 AND 101). REG. 2-19-2002.
- 2,539,692. AMINOLAB. INT. CL. 42. (U.S. CLS. 100 AND 101). REG. 2-19-2002.
- 2,539,781. LCEC. INT. CL. 42. (U.S. CLS. 100 AND 101). REG. 2-19-2002.
- 2,539,936. X-MEN: EVOLUTION. INT. CL. 41. (U.S. CLS. 100, 101 AND 107). REG. 2-19-2002.
- 2,539,993. LETHAL WEAPON. INT. CL. 28. (U.S. CLS. 22, 23, 38 AND 50). REG. 2-19-2002.
- 2,540,284. BIBICA AND DESIGN. INT. CL. 30. (U.S. CL. 46). REG. 2-19-2002.
- 2,540,306. OVEN TOASTED TASTES BETTER. INT. CL. 30. (U.S. CL. 46). REG. 2-19-2002.
- 2,540,376. BEHIND THE NUMBERS. INT. CLS. 35 AND 42. (U.S. CLS. 100, 101 AND 102). REG. 2-19-2002.
- 2,540,614. SEVEN SEAS MARINER. INT. CL. 39. (U.S. CLS. 100 AND 105). REG. 2-19-2002.
- 2,540,624. CUP OF EXCELLENCE. INT. CL. 30. (U.S. CL. 46). REG. 2-19-2002.
- 2,540,791. LI. INT. CL. 6. (U.S. CLS. 2, 12, 13, 14, 23, 25 AND 50). REG. 2-19-2002.
- 2,540,852. GAS GUY. INT. CL. 39. (U.S. CLS. 100 AND 105). REG. 2-19-2002.
- 2,540,932. SWEET BITES. INT. CL. 30. (U.S. CL. 46). REG. 2-19-2002.
- 2,541,016. EBRARY. INT. CL. 42. (U.S. CLS. 100 AND 101). REG. 2-19-2002.
- 2,541,088. SWISS-SHIELD. INT. CL. 24 ONLY. (U.S. CLS. 42 AND 50). REG. 2-19-2002.
- 2,541,122. CARBONX. INT. CL. 24. (U.S. CLS. 42 AND 50). REG. 2-19-2002.
- 2,541,131. V (STYLIZED). INT. CL. 1. (U.S. CLS. 1, 5, 6, 10, 26 AND 46). REG. 2-19-2002.
- 2,541,219. FISHPOND AND DESIGN. INT. CL. 28. (U.S. CLS. 22, 23, 38 AND 50). REG. 2-19-2002.
- 2,541,251. BABY PHAT AND DESIGN. INT. CL. 18. (U.S. CLS. 1, 2, 3, 22 AND 41). REG. 2-19-2002.
- 2,541,346. A AND DESIGN. INT. CL. 9. (U.S. CLS. 21, 23, 26, 36 AND 38). REG. 2-19-2002.
- 2,541,397. PINEDA COVALIN. INT. CL. 25. (U.S. CLS. 22 AND 39). REG. 2-19-2002.
- 2,541,868. DIAMONDS ON A WIRE. INT. CL. 14 ONLY. (U.S. CLS. 2, 27, 28 AND 50). REG. 2-19-2002.
- 2,542,069. DUSENFLO. INT. CL. 11. (U.S. CLS. 13, 21, 23, 31 AND 34). REG. 2-26-2002.
- 2,542,184. MARY KAY (STYLIZED). INT. CLS. 3, 9, 16 AND 21 ONLY. (U.S. CLS. 1, 2, 4, 5, 6, 13, 21, 22, 23, 26, 29, 30, 33, 36, 37, 38, 40, 50, 51 AND 52). REG. 2-26-2002.
- 2,542,199. GET THE GRIP (STYLIZED). INT. CL. 12. (U.S. CLS. 19, 21, 23, 31, 35 AND 44). REG. 2-26-2002.
- 2,542,420. M AND DESIGN. INT. CL. 9. (U.S. CLS. 21, 23, 26, 36 AND 38). REG. 2-26-2002.
- 2,542,678. THE SAFETY DIRECTOR. INT. CL. 9. (U.S. CLS. 21, 23, 26, 36 AND 38). REG. 2-26-2002.
- 2,542,698. CELLUTOX. INT. CL. 5. (U.S. CLS. 6, 18, 44, 46, 51 AND 52). REG. 2-26-2002.
- 2,542,864. CORONADO. INT. CL. 16. (U.S. CLS. 2, 5, 22, 23, 29, 37, 38 AND 50). REG. 2-26-2002.
- 2,543,023. ECONUGENICS. INT. CLS. 35 AND 42. (U.S. CLS. 100, 101 AND 102). REG. 2-26-2002.
- 2,543,046. TERRY'S VILLAGE. INT. CL. 35. (U.S. CLS. 100, 101 AND 102). REG. 2-26-2002.
- 2,543,070. WORLD TECHNOLOGY WATCH AND DESIGN. INT. CL. 35. (U.S. CLS. 100, 101 AND 102). REG. 2-26-2002.
- 2,543,231. UNITED PHYSICIANS OF AMERICA AND DESIGN. INT. CL. 42. (U.S. CLS. 100 AND 101). REG. 2-26-2002.
- 2,543,469. SEAMATE. INT. CL. 1. (U.S. CLS. 1, 5, 6, 10, 26 AND 46). REG. 2-26-2002.
- 2,543,539. HYPERSEND. INT. CL. 35. (U.S. CLS. 100, 101 AND 102). REG. 2-26-2002.
- 2,543,972. BCTGM POWER WORKS FOR YOU!. INT. CL. 42. (U.S. CLS. 100 AND 101). REG. 3-5-2002.
- 2,543,992. B AND DESIGN. INT. CL. 40. (U.S. CLS. 100, 103 AND 106). REG. 3-5-2002.
- 2,544,008. BODY CLEAR. INT. CL. 5. (U.S. CLS. 6, 18, 44, 46, 51 AND 52). REG. 3-5-2002.
- 2,544,111. CREATIVE MIND PROFILE. INT. CL. 16. (U.S. CLS. 2, 5, 22, 23, 29, 37, 38 AND 50). REG. 3-5-2002.
- 2,544,112. THE FEEDBACK WHEEL. INT. CL. 16. (U.S. CLS. 2, 5, 22, 23, 29, 37, 38 AND 50). REG. 3-5-2002.
- 2,544,817. FRED SOLL'S. INT. CL. 3. (U.S. CLS. 1, 4, 6, 50, 51 AND 52). REG. 3-5-2002.
- 2,544,950. BLUE OPTIONS. INT. CLS. 36 AND 42. (U.S. CLS. 100, 101 AND 102). REG. 3-5-2002.
- 2,544,951. BLUE ACCESS. INT. CLS. 36 AND 42. (U.S. CLS. 100, 101 AND 102). REG. 3-5-2002.
- 2,545,082. MAD CATZ AND DESIGN. INT. CL. 9. (U.S. CLS. 21, 23, 26, 36 AND 38). REG. 3-5-2002.
- 2,545,124. JUST ADD PAINT!. INT. CL. 16. (U.S. CLS. 2, 5, 22, 23, 29, 37, 38 AND 50). REG. 3-5-2002.
- 2,545,181. SAFETY STEP. INT. CL. 17. (U.S. CLS. 1, 5, 12, 13, 35 AND 50). REG. 3-5-2002.
- 2,545,478. COURTPORTERS.COM. INT. CL. 9. (U.S. CLS. 21, 23, 26, 36 AND 38). REG. 3-5-2002.
- 2,546,102. PHYTOMAN. INT. CL. 25. (U.S. CLS. 22 AND 39). REG. 3-12-2002.
- 2,546,104. PHYTOWOMAN. INT. CL. 25. (U.S. CLS. 22 AND 39). REG. 3-12-2002.
- 2,546,286. INCOTERMS FOR AMERICANS. INT. CL. 16. (U.S. CLS. 2, 5, 22, 23, 29, 37, 38 AND 50). REG. 3-12-2002.
- 2,546,675. FAM. INT. CL. 9. (U.S. CLS. 21, 23, 26, 36 AND 38). REG. 3-12-2002.
- 2,546,814. VPVIEW. INT. CL. 9. (U.S. CLS. 21, 23, 26, 36 AND 38). REG. 3-12-2002.
- 2,547,280. RANDY HANGERS. INT. CL. 20. (U.S. CLS. 2, 13, 22, 25, 32 AND 50). REG. 3-12-2002.
- 2,547,298. YOUR BODY CODE. INT. CL. 42. (U.S. CLS. 100 AND 101). REG. 3-12-2002.
- 2,547,330. GASTRICAID. INT. CL. 5. (U.S. CLS. 6, 18, 44, 46, 51 AND 52). REG. 3-12-2002.
- 2,547,385. INTERACT I CLUB AND DESIGN. INT. CL. 25. (U.S. CLS. 22 AND 39). REG. 3-12-2002.
- 2,547,557. TOWEL BABY. INT. CL. 25. (U.S. CLS. 22 AND 39). REG. 3-12-2002.
- 2,547,657. HARVEST FORGE. INT. CLS. 8 AND 22. (U.S. CLS. 1, 2, 7, 19, 22, 23, 28, 42, 44 AND 50). REG. 3-12-2002.
- 2,547,780. SALPICA. INT. CL. 30. (U.S. CL. 46). REG. 3-12-2002.
- 2,547,793. CEDAR CREST VILLAGE. INT. CL. 42. (U.S. CLS. 100 AND 101). REG. 3-12-2002.
- 2,547,960. 23. INT. CL. 42. (U.S. CLS. 100 AND 101). REG. 3-12-2002.
- 2,548,257. ESPECIALLY FOR BABY. INT. CLS. 8, 10, 21 AND 25 ONLY. (U.S. CLS. 2, 13, 22, 23, 26, 28, 29, 30, 33, 39, 40, 44 AND 50). REG. 3-12-2002.
- 2,548,345. SPEEDREEL. INT. CL. 9. (U.S. CLS. 21, 23, 26, 36 AND 38). REG. 3-12-2002.
- 2,548,753. RX DRILLER AND DESIGN. INT. CL. 6. (U.S. CLS. 2, 12, 13, 14, 23, 25 AND 50). REG. 3-19-2002.
- 2,549,098. BASS FEDERATION NATION CHAMPIONSHIP. INT. CL. 41. (U.S. CLS. 100, 101 AND 107). REG. 3-19-2002.
- 2,549,639. TUBESCREAMER. INT. CL. 9. (U.S. CLS. 21, 23, 26, 36 AND 38). REG. 3-19-2002.
- 2,550,019. USBPRE. INT. CL. 9. (U.S. CLS. 21, 23, 26, 36 AND 38). REG. 3-19-2002.
- 2,550,290. Q-PAK. INT. CL. 9. (U.S. CLS. 21, 23, 26, 36 AND 38). REG. 3-19-2002.
- 2,550,391. ERSASCOPE. INT. CLS. 9, 10 AND 11. (U.S. CLS. 13, 21, 23, 26, 31, 34, 36, 38, 39 AND 44). REG. 3-19-2002.
- 2,550,429. CONSIGNMENT 1ST. INT. CL. 35. (U.S. CLS. 100, 101 AND 102). REG. 3-19-2002.
- 2,550,804. GAMBRO. INT. CL. 10. (U.S. CLS. 26, 39 AND 44). REG. 3-19-2002.
- 2,550,805. GAMBRO AND DESIGN. INT. CL. 5. (U.S. CLS. 6, 18, 44, 46, 51 AND 52). REG. 3-19-2002.
- 2,551,871. ORAFOL. INT. CLS. 16 AND 17 ONLY. (U.S. CLS. 1, 2, 5, 12, 13, 22, 23, 29, 35, 37, 38 AND 50). REG. 3-26-2002.

- 2,551,971. APERTURE. INT. CLS. 35 AND 42. (U.S. CLS. 100, 101 AND 102). REG. 3-26-2002.
- 2,552,075. A NITE TO UNITE FOR KIDS AND DESIGN. INT. CL. 36. (U.S. CLS. 100, 101 AND 102). REG. 3-26-2002.
- 2,552,600. TASTE, LUXURY, HUMOR. INT. CL. 35. (U.S. CLS. 100, 101 AND 102). REG. 3-26-2002.
- 2,552,932. SECOND CUP COFFEE CO. AND DESIGN. INT. CL. 35 ONLY. (U.S. CLS. 100, 101 AND 102). REG. 3-26-2002.
- 2,553,075. SPORTSWRITER. INT. CL. 9. (U.S. CLS. 21, 23, 26, 36 AND 38). REG. 3-26-2002.
- 2,553,245. EFLEX. INT. CL. 10. (U.S. CLS. 26, 39 AND 44). REG. 3-26-2002.
- 2,553,625. GAMBRO. INT. CL. 5. (U.S. CLS. 6, 18, 44, 46, 51 AND 52). REG. 3-26-2002.
- 2,553,626. GAMBRO AND DESIGN. INT. CL. 10. (U.S. CLS. 26, 39 AND 44). REG. 3-26-2002.
- 2,554,120. KELATE. INT. CL. 3. (U.S. CLS. 1, 4, 6, 50, 51 AND 52). REG. 3-26-2002.
- 2,554,474. DRI-SATE. INT. CL. 5. (U.S. CLS. 6, 18, 44, 46, 51 AND 52). REG. 4-2-2002.
- 2,554,675. WINDSOR. INT. CL. 35. (U.S. CLS. 100, 101 AND 102). REG. 4-2-2002.
- 2,554,684. STARBRIGHT WORLD. INT. CL. 38 ONLY. (U.S. CLS. 100, 101 AND 104). REG. 4-2-2002.
- 2,554,845. MAGIC CASTLE. INT. CLS. 25, 41 AND 42. (U.S. CLS. 22, 39, 100, 101 AND 107). REG. 4-2-2002.
- 2,555,156. HEALTHCARE RECOVERIES AND DESIGN. INT. CL. 36. (U.S. CLS. 100, 101 AND 102). REG. 4-2-2002.
- 2,555,157. HEALTHCARE RECOVERIES. INT. CL. 36. (U.S. CLS. 100, 101 AND 102). REG. 4-2-2002.
- 2,555,797. ARES. INT. CL. 42. (U.S. CLS. 100 AND 101). REG. 4-2-2002.
- 2,555,969. PROMEGA. INT. CL. 5. (U.S. CLS. 6, 18, 44, 46, 51 AND 52). REG. 4-2-2002.
- 2,556,000. MISCELLANEOUS DESIGN. INT. CL. 29. (U.S. CL. 46). REG. 4-2-2002.
- 2,556,052. AUTO-GUARD AND DESIGN. INT. CL. 12. (U.S. CLS. 19, 21, 23, 31, 35 AND 44). REG. 4-2-2002.
- 2,556,111. RETIREMENT FOCUS. INT. CL. 36. (U.S. CLS. 100, 101 AND 102). REG. 4-2-2002.
- 2,556,254. MISCELLANEOUS DESIGN. INT. CL. 11. (U.S. CLS. 13, 21, 23, 31 AND 34). REG. 4-2-2002.
- 2,556,421. IWJ. INT. CL. 12. (U.S. CLS. 19, 21, 23, 31, 35 AND 44). REG. 4-2-2002.
- 2,556,498. LEGGMASON.COM. INT. CL. 36. (U.S. CLS. 100, 101 AND 102). REG. 4-2-2002.
- 2,556,946. FEDERAL CITY DELI. INT. CL. 42. (U.S. CLS. 100 AND 101). REG. 4-2-2002.
- 2,557,650. PASSPORT TO HEALTH MEMORIAL HOSPITAL AND DESIGN. INT. CL. 41. (U.S. CLS. 100, 101 AND 107). REG. 4-9-2002.
- 2,557,870. ARUS. INT. CLS. 24 AND 25. (U.S. CLS. 22, 39, 42 AND 50). REG. 4-9-2002.
- 2,557,995. LIGHTCRAFT TECHNOLOGIES. INT. CL. 42. (U.S. CLS. 100 AND 101). REG. 4-9-2002.
- 2,558,324. OHIO CATTLEMEN'S ASSOCIATION. U.S. CL. 200. REG. 4-9-2002.
- 2,558,476. CHEESE CLUB. INT. CL. 30. (U.S. CL. 46). REG. 4-9-2002.
- 2,558,640. NA-LINK. INT. CL. 42. (U.S. CLS. 100 AND 101). REG. 4-9-2002.
- 2,559,914. GENUNET. INT. CL. 42. (U.S. CLS. 100 AND 101). REG. 4-9-2002.
- 2,560,072. BRIK. INT. CL. 9. (U.S. CLS. 21, 23, 26, 36 AND 38). REG. 4-9-2002.
- 2,560,161. SWING-MATE. INT. CL. 6. (U.S. CLS. 2, 12, 13, 14, 23, 25 AND 50). REG. 4-9-2002.
- 2,560,459. MILLI-DI. INT. CL. 11. (U.S. CLS. 13, 21, 23, 31 AND 34). REG. 4-9-2002.
- 2,560,598. BLOOD CLEANSE. INT. CL. 5. (U.S. CLS. 6, 18, 44, 46, 51 AND 52). REG. 4-9-2002.
- 2,560,799. ROCKWELL MEDICAL TECHNOLOGIES, INC.. INT. CLS. 5 AND 10. (U.S. CLS. 6, 18, 26, 39, 44, 46, 51 AND 52). REG. 4-16-2002.
- 2,560,871. ZELLER + GMELIN AND DESIGN. INT. CLS. 1, 2 AND 3. (U.S. CLS. 1, 4, 5, 6, 10, 11, 16, 26, 46, 50, 51 AND 52). REG. 4-16-2002.
- 2,560,929. E-UNDERWEAR.COM. INT. CL. 25. (U.S. CLS. 22 AND 39). REG. 4-16-2002.
- 2,561,013. DI-STRIP AND DESIGN. INT. CL. 9. (U.S. CLS. 21, 23, 26, 36 AND 38). REG. 4-16-2002.
- 2,561,056. HDVLINK. INT. CLS. 35, 36 AND 42. (U.S. CLS. 100, 101 AND 102). REG. 4-16-2002.
- 2,561,147. CUAMINE. INT. CL. 1. (U.S. CLS. 1, 5, 6, 10, 26 AND 46). REG. 4-16-2002.
- 2,561,672. FIGURE EIGHT ISLAND YACHT CLUB 8 AND DESIGN. INT. CLS. 25 AND 41. (U.S. CLS. 22, 39, 100, 101 AND 107). REG. 4-16-2002.
- 2,561,853. PERSONALIZATION MALL. INT. CL. 35. (U.S. CLS. 100, 101 AND 102). REG. 4-16-2002.
- 2,562,659. BROADCASTING CONTINUING LEGAL EDUCATION AND PROGRAMMING ON THE INTERNET. INT. CLS. 41 AND 42. (U.S. CLS. 100, 101 AND 107). REG. 4-16-2002.
- 2,562,820. CELEBRATION. INT. CL. 42. (U.S. CLS. 100 AND 101). REG. 4-23-2002.
- 2,563,234. ENVIRO SHIELD PRODUCTS. INT. CL. 17. (U.S. CLS. 1, 5, 12, 13, 35 AND 50). REG. 4-23-2002.
- 2,563,399. CG T DER. INT. CL. 7. (U.S. CLS. 13, 19, 21, 23, 31, 34 AND 35). REG. 4-23-2002.
- 2,563,528. AGC THE CREATIVE ADVANTAGE AND DESIGN. INT. CL. 42. (U.S. CLS. 100 AND 101). REG. 4-23-2002.
- 2,564,119. EASYANNUITY. INT. CL. 36. (U.S. CLS. 100, 101 AND 102). REG. 4-23-2002.
- 2,564,230. EPIFACIAL. INT. CL. 42. (U.S. CLS. 100 AND 101). REG. 4-23-2002.
- 2,564,473. PERTH. INT. CL. 20. (U.S. CLS. 2, 13, 22, 25, 32 AND 50). REG. 4-23-2002.
- 2,564,545. PORTOLANO KIDS AND DESIGN. INT. CL. 25. (U.S. CLS. 22 AND 39). REG. 4-23-2002.
- 2,567,019. PATIENTKEEPER. INT. CL. 9. (U.S. CLS. 21, 23, 26, 36 AND 38). REG. 5-7-2002.
- 2,567,160. EMA FOUNDATION FOR PAPER-BASED COMMUNICATIONS AND DESIGN. INT. CLS. 41 AND 42. (U.S. CLS. 100, 101 AND 107). REG. 5-7-2002.
- 2,567,174. AIG AND DESIGN. INT. CL. 28. (U.S. CLS. 22, 23, 38 AND 50). REG. 5-7-2002.
- 2,567,241. SIR'S KNOWLEDGE SOURCE. INT. CL. 42. (U.S. CLS. 100 AND 101). REG. 5-7-2002.
- 2,567,286. K (STYLIZED). INT. CL. 42. (U.S. CLS. 100 AND 101). REG. 5-7-2002.
- 2,567,550. SITUATIONAL SERVICE. INT. CL. 16. (U.S. CLS. 2, 5, 22, 23, 29, 37, 38 AND 50). REG. 5-7-2002.
- 2,569,422. HYTEST SAFETY FOOTWEAR AND DESIGN. INT. CL. 25. (U.S. CLS. 19, 22 AND 39). REG. 5-14-2002.
- 2,569,513. PBM. INT. CL. 7. (U.S. CLS. 13, 19, 21, 23, 31, 34 AND 35). REG. 5-14-2002.
- 2,571,058. SEEIDEAS PRODUCT DEVELOPMENT AND DESIGN. INT. CL. 42. (U.S. CLS. 100 AND 101). REG. 5-21-2002.
- 2,571,144. DAVE CUMMINGS. INT. CL. 41. (U.S. CLS. 100, 101 AND 107). REG. 5-21-2002.
- 2,571,330. OSPREY AND DESIGN. INT. CL. 18. (U.S. CLS. 1, 2, 3, 22 AND 41). REG. 5-21-2002.
- 2,572,467. CONSOCIA + E GROUP AND DESIGN. INT. CL. 36 ONLY. (U.S. CLS. 100, 101 AND 102). REG. 5-28-2002.
- 2,572,768. LC (STYLIZED). INT. CL. 7. (U.S. CLS. 13, 19, 21, 23, 31, 34 AND 35). REG. 5-28-2002.
- 2,573,065. TSAR. INT. CL. 29. (U.S. CL. 46). REG. 5-28-2002.
- 2,575,734. MISCELLANEOUS DESIGN. INT. CLS. 16 AND 41. (U.S. CLS. 2, 5, 22, 23, 29, 37, 38, 50, 100, 101 AND 107). REG. 6-4-2002.
- 2,576,121. MD 3200. INT. CL. 21. (U.S. CLS. 2, 13, 23, 29, 30, 33, 40 AND 50). REG. 6-4-2002.
- 2,577,739. SPRINGBOARD. INT. CLS. 36 AND 41. (U.S. CLS. 100, 101, 102 AND 107). REG. 6-11-2002.
- 2,578,082. TIMES DIGEST (STYLIZED). INT. CLS. 16 AND 42. (U.S. CLS. 2, 5, 22, 23, 29, 37, 38, 50, 100 AND 101). REG. 6-11-2002.
- 2,578,723. PREGGUARD. INT. CL. 5. (U.S. CLS. 6, 18, 44, 46, 51 AND 52). REG. 6-11-2002.
- 2,579,703. RESOLUTION. INT. CL. 9. (U.S. CLS. 21, 23, 26, 36 AND 38). REG. 6-11-2002.
- 2,579,796. RECUERDO. INT. CLS. 35, 38 AND 41. (U.S. CLS. 100, 101, 102, 104 AND 107). REG. 6-11-2002.
- 2,580,812. AMER. INT. CLS. 7 AND 12. (U.S. CLS. 13, 19, 21, 23, 31, 34, 35 AND 44). REG. 6-18-2002.
- 2,582,150. ETI. INT. CL. 12. (U.S. CLS. 19, 21, 23, 31, 35 AND 44). REG. 6-18-2002.
- 2,582,229. HUSTLER'S TABOO. INT. CL. 41. (U.S. CLS. 100, 101 AND 107). REG. 6-18-2002.

- 2,582,354. PET ESSENCES. INT. CL. 5. (U.S. CLS. 6, 18, 44, 46, 51 AND 52). REG. 6-18-2002.
- 2,582,735. LEGEND ELITE. INT. CL. 28. (U.S. CLS. 22, 23, 38 AND 50). REG. 6-18-2002.
- 2,584,070. CE MANAGER. INT. CL. 9. (U.S. CLS. 21, 23, 26, 36 AND 38). REG. 6-18-2002.
- 2,584,690. MORNING STAR PICTURES. INT. CL. 35. (U.S. CLS. 100, 101 AND 102). REG. 6-25-2002.
- 2,584,982. MARINA JACK AND DESIGN. INT. CLS. 39 AND 42. (U.S. CLS. 100, 101 AND 105). REG. 6-25-2002.
- 2,585,221. TEGRA GROUP. INT. CL. 36. (U.S. CLS. 100, 101 AND 102). REG. 6-25-2002.
- 2,587,818. TECH AUTHORITY. INT. CL. 16. (U.S. CLS. 2, 5, 22, 23, 29, 37, 38 AND 50). REG. 7-2-2002.
- 2,588,652. EXOSAP-IT. INT. CL. 5. (U.S. CLS. 6, 18, 44, 46, 51 AND 52). REG. 7-2-2002.
- 2,588,863. ARGALI. INT. CL. 9. (U.S. CLS. 21, 23, 26, 36 AND 38). REG. 7-2-2002.
- 2,590,739. F (STYLIZED). INT. CL. 41. (U.S. CLS. 100, 101 AND 107). REG. 7-9-2002.
- 2,590,932. PENNNET (STYLIZED). INT. CLS. 38 AND 41. (U.S. CLS. 100, 101, 104 AND 107). REG. 7-9-2002.
- 2,593,360. HOMEFIND. INT. CL. 35. (U.S. CLS. 100, 101 AND 102). REG. 7-16-2002.
- 2,593,887. ENERGY HANSENS AND DESIGN. INT. CL. 32. (U.S. CLS. 45, 46 AND 48). REG. 7-16-2002.
- 2,594,182. GLYNN ELECTRIC AND DESIGN. INT. CL. 37. (U.S. CLS. 100, 103 AND 106). REG. 7-16-2002.
- 2,597,777. E-P EXPRESS. INT. CL. 7. (U.S. CLS. 13, 19, 21, 23, 31, 34 AND 35). REG. 7-23-2002.
- 2,598,522. 23. INT. CLS. 6, 21 AND 25 ONLY. (U.S. CLS. 2, 12, 13, 14, 22, 23, 25, 29, 30, 33, 39, 40 AND 50). REG. 7-23-2002.
- 2,599,683. REX 4. INT. CL. 5. (U.S. CLS. 6, 18, 44, 46, 51 AND 52). REG. 7-23-2002.
- 2,602,102. MEDGE PLATFORMS. INT. CL. 9. (U.S. CLS. 21, 23, 26, 36 AND 38). REG. 7-30-2002.
- 2,602,146. TIP-SEAL. INT. CL. 9. (U.S. CLS. 21, 23, 26, 36 AND 38). REG. 7-30-2002.
- 2,602,506. V-ROD. INT. CL. 12. (U.S. CLS. 19, 21, 23, 31, 35 AND 44). REG. 7-30-2002.
- 2,603,517. K. INT. CL. 42. (U.S. CLS. 100 AND 101). REG. 8-6-2002.
- 2,603,709. 4TH WAVE IMAGING. INT. CLS. 35 AND 42. (U.S. CLS. 100, 101 AND 102). REG. 8-6-2002.
- 2,604,508. MEDAXIOM. INT. CL. 35. (U.S. CLS. 100, 101 AND 102). REG. 8-6-2002.
- 2,604,769. ULTIMO! AND DESIGN. INT. CLS. 29 AND 30. (U.S. CL. 46). REG. 8-6-2002.
- 2,606,063. REX CC. INT. CL. 5. (U.S. CLS. 6, 18, 44, 46, 51 AND 52). REG. 8-6-2002.
- 2,606,164. WINDOW WRITER. INT. CL. 16. (U.S. CLS. 2, 5, 22, 23, 29, 37, 38 AND 50). REG. 8-6-2002.
- 2,606,905. ONESTEP. INT. CL. 10. (U.S. CLS. 26, 39 AND 44). REG. 8-13-2002.
- 2,611,762. MORNING STAR PICTURES AND DESIGN. INT. CL. 35. (U.S. CLS. 100, 101 AND 102). REG. 8-27-2002.
- 2,611,953. LEWIS AND ROCA. INT. CL. 42. (U.S. CLS. 100 AND 101). REG. 8-27-2002.
- 2,612,235. NAAA. INT. CL. 42. (U.S. CLS. 100 AND 101). REG. 8-27-2002.
- 2,613,122. DMX DIRECT. INT. CL. 35. (U.S. CLS. 100, 101 AND 102). REG. 8-27-2002.
- 2,614,011. BRAKE MASTERS AND DESIGN. INT. CL. 37. (U.S. CLS. 100, 103 AND 106). REG. 9-3-2002.
- 2,614,239. THE RENAISSANCE COLLECTION. INT. CLS. 6 AND 20. (U.S. CLS. 2, 12, 13, 14, 22, 23, 25, 32 AND 50). REG. 9-3-2002.
- 2,615,082. SDCAA. INT. CL. 42. (U.S. CLS. 100 AND 101). REG. 9-3-2002.
- 2,617,073. SOILING SOLUTIONS AND DESIGN. INT. CL. 16 ONLY. (U.S. CLS. 2, 5, 22, 23, 29, 37, 38 AND 50). REG. 9-10-2002.
- 2,618,095. SHOP WITH A JOCK. INT. CL. 42. (U.S. CLS. 100 AND 101). REG. 9-10-2002.
- 2,620,063. CAMEL TURKISH GOLD. INT. CL. 34. (U.S. CLS. 2, 8, 9 AND 17). REG. 9-17-2002.
- 2,621,016. ADVANCES. INT. CL. 36. (U.S. CLS. 100, 101 AND 102). REG. 9-17-2002.
- 2,621,534. JUNIPER BREEZE. INT. CLS. 3, 4 AND 5 ONLY. (U.S. CLS. 1, 4, 6, 15, 18, 44, 46, 50, 51 AND 52). REG. 9-17-2002.
- 2,622,584. LOVEYWEAR AND DESIGN. INT. CL. 25. (U.S. CLS. 22 AND 39). REG. 9-24-2002.
- 2,623,385. WEILER AND DESIGN. INT. CL. 7. (U.S. CLS. 13, 19, 21, 23, 31, 34 AND 35). REG. 9-24-2002.
- 2,623,436. GOLDLINE. INT. CL. 29. (U.S. CL. 46). REG. 9-24-2002.
- 2,623,620. KROGER. INT. CLS. 3, 6, 8, 16, 20 AND 21 ONLY. (U.S. CLS. 1, 2, 4, 5, 6, 12, 13, 14, 22, 23, 25, 28, 29, 30, 32, 33, 37, 38, 40, 44, 50, 51 AND 52). REG. 9-24-2002.
- 2,623,868. ANNIE CHUN'S. INT. CL. 30. (U.S. CL. 46). REG. 9-24-2002.
- 2,624,033. SHONOL. INT. CL. 1. (U.S. CLS. 1, 5, 6, 10, 26 AND 46). REG. 9-24-2002.
- 2,627,455. DEMO GODS. INT. CL. 41. (U.S. CLS. 100, 101 AND 107). REG. 10-1-2002.
- 2,627,831. MISCELLANEOUS DESIGN. INT. CLS. 35, 38 AND 41. (U.S. CLS. 100, 101, 102, 104 AND 107). REG. 10-1-2002.
- 2,627,865. VITA NICE BREATH NEW VITA AND DESIGN. INT. CL. 5. (U.S. CLS. 6, 18, 44, 46, 51 AND 52). REG. 10-1-2002.
- 2,627,929. AMERICAN FUNDS. INT. CL. 36. (U.S. CLS. 100, 101 AND 102). REG. 10-1-2002.
- 2,629,402. JOBELAN. INT. CL. 24. (U.S. CLS. 42 AND 50). REG. 10-1-2002.
- 2,629,755. TEXANS CHECK CARD. INT. CL. 36. (U.S. CLS. 100, 101 AND 102). REG. 10-8-2002.
- 2,630,917. R AND DESIGN. INT. CL. 25. (U.S. CLS. 22 AND 39). REG. 10-8-2002.
- 2,630,940. HEY-FEAVER NEW VITA AND DESIGN. INT. CL. 5. (U.S. CLS. 6, 18, 44, 46, 51 AND 52). REG. 10-8-2002.
- 2,630,941. NICE LEAN NEW VITA AND DESIGN. INT. CL. 5. (U.S. CLS. 6, 18, 44, 46, 51 AND 52). REG. 10-8-2002.
- 2,631,777. ERI AND DESIGN. INT. CL. 16. (U.S. CLS. 2, 5, 22, 23, 29, 37, 38 AND 50). REG. 10-8-2002.
- 2,631,962. NAPANOOK. INT. CL. 33. (U.S. CLS. 47 AND 49). REG. 10-8-2002.
- 2,631,968. SAFETY REPAIR. INT. CL. 12. (U.S. CLS. 19, 21, 23, 31, 35 AND 44). REG. 10-8-2002.
- 2,633,229. VICTORIAN. INT. CL. 33. (U.S. CLS. 47 AND 49). REG. 10-8-2002.
- 2,633,487. KENNEDY. INT. CLS. 7, 9 AND 11 ONLY. (U.S. CLS. 13, 19, 21, 23, 26, 31, 34, 35, 36 AND 38). REG. 10-8-2002.
- 2,633,902. CRP. INT. CL. 41. (U.S. CLS. 100, 101 AND 107). REG. 10-15-2002.
- 2,634,227. ACCUNET MORTGAGE STANDARD CHARACTER MARK. INT. CL. 36. (U.S. CLS. 100, 101 AND 102). REG. 10-15-2002.
- 2,634,257. KROGER AND DESIGN. INT. CL. 35. (U.S. CLS. 100, 101 AND 102). REG. 10-15-2002.
- 2,635,121. EVERYCHILD. INT. CL. 36. (U.S. CLS. 100, 101 AND 102). REG. 10-15-2002.
- 2,636,756. PERCEPT. INT. CL. 21. (U.S. CLS. 2, 13, 23, 29, 30, 33, 40 AND 50). REG. 10-15-2002.
- 2,638,149. MAITRE'D. INT. CL. 9. (U.S. CLS. 21, 23, 26, 36 AND 38). REG. 10-22-2002.
- 2,638,889. FREEZE FREE. INT. CL. 11. (U.S. CLS. 13, 21, 23, 31 AND 34). REG. 10-22-2002.
- 2,639,155. H. S. CROCKER. INT. CL. 42. (U.S. CLS. 100 AND 101). REG. 10-22-2002.
- 2,639,395. PAYGRO. INT. CLS. 1 AND 31. (U.S. CLS. 1, 5, 6, 10, 26 AND 46). REG. 10-22-2002.
- 2,639,594. CHRISTIANBOOK.COM AND DESIGN. INT. CLS. 35, 41 AND 42. (U.S. CLS. 100, 101, 102 AND 107). REG. 10-22-2002.
- 2,640,321. WATERSENSE WATER TREATMENT CHEMISTRY & EQUIPMENT AND DESIGN. INT. CLS. 1, 11 AND 40. (U.S. CLS. 1, 5, 6, 10, 13, 21, 23, 26, 31, 34, 46, 100, 103 AND 106). REG. 10-22-2002.
- 2,641,565. SYNERGY WORLDWIDE. INT. CLS. 11 AND 35. (U.S. CLS. 13, 21, 23, 31, 34, 100, 101 AND 102). REG. 10-29-2002.
- 2,642,111. OPRC OLD PEOPLE'S RIDING CLUB AND DESIGN. INT. CL. 41. (U.S. CLS. 100, 101 AND 107). REG. 10-29-2002.
- 2,642,503. QUILT. INT. CL. 16. (U.S. CLS. 2, 5, 22, 23, 29, 37, 38 AND 50). REG. 10-29-2002.
- 2,642,711. ISLAND REFRESHMENTS. INT. CL. 43. (U.S. CLS. 100 AND 101). REG. 10-29-2002.
- 2,643,230. LICEMEISTER. INT. CL. 10. (U.S. CLS. 26, 39 AND 44). REG. 10-29-2002.
- 2,644,821. EFAX CORPORATE. INT. CL. 38. (U.S. CLS. 100, 101 AND 104). REG. 10-29-2002.

- 2,644,874. LIFE. INT. CL. 10. (U.S. CLS. 26, 39 AND 44). REG. 11-5-2002.
- 2,645,126. VECTOR CAPITAL. INT. CL. 36. (U.S. CLS. 100, 101 AND 102). REG. 11-5-2002.
- 2,645,171. ORGANIZER. INT. CL. 12. (U.S. CLS. 19, 21, 23, 31, 35 AND 44). REG. 11-5-2002.
- 2,645,682. JESSICA LONDON. INT. CL. 35. (U.S. CLS. 100, 101 AND 102). REG. 11-5-2002.
- 2,647,553. GRIPLID. INT. CL. 21. (U.S. CLS. 2, 13, 23, 29, 30, 33, 40 AND 50). REG. 11-5-2002.
- 2,648,286. ACCUNET MORTGAGE AND DESIGN. INT. CL. 36. (U.S. CLS. 100, 101 AND 102). REG. 11-12-2002.
- 2,648,553. CAROLINA DOOR CONTROLS, INC.. INT. CL. 37. (U.S. CLS. 100, 103 AND 106). REG. 11-12-2002.
- 2,648,839. HERITAGE. INT. CL. 36. (U.S. CLS. 100, 101 AND 102). REG. 11-12-2002.
- 2,649,247. Y.E.S.. INT. CL. 36. (U.S. CLS. 100, 101 AND 102). REG. 11-12-2002.
- 2,649,248. YOU'RE ESSENTIAL TO SAFETY. INT. CL. 36. (U.S. CLS. 100, 101 AND 102). REG. 11-12-2002.
- 2,649,452. CAVITRON. INT. CL. 10. (U.S. CLS. 26, 39 AND 44). REG. 11-12-2002.
- 2,649,616. THE SCIENCE ADVISORY BOARD AND DESIGN. INT. CL. 44. (U.S. CLS. 100 AND 101). REG. 11-12-2002.
- 2,649,753. NUCARA. INT. CLS. 5 AND 35. (U.S. CLS. 6, 18, 44, 46, 51, 52, 100, 101 AND 102). REG. 11-12-2002.
- 2,649,910. EKADURE. INT. CL. 1. (U.S. CLS. 1, 5, 6, 10, 26 AND 46). REG. 11-12-2002.
- 2,649,963. PRIMEVAL WHIRL. INT. CL. 41. (U.S. CLS. 100, 101 AND 107). REG. 11-12-2002.
- 2,650,244. EDGE OF THE PLATE. INT. CL. 30. (U.S. CL. 46). REG. 11-12-2002.
- 2,650,866. TOP 20 ON 20 STANDARD CHARACTER MARK. INT. CL. 41. (U.S. CLS. 100, 101 AND 107). REG. 11-12-2002.
- 2,651,038. FRANZ JUNGER. INT. CL. 15. (U.S. CLS. 2, 21 AND 36). REG. 11-19-2002.
- 2,651,052. ORGANIZER AND DESIGN. INT. CL. 16. (U.S. CLS. 2, 5, 22, 23, 29, 37, 38 AND 50). REG. 11-19-2002.
- 2,651,489. JPMORGAN. INT. CL. 36. (U.S. CLS. 100, 101 AND 102). REG. 11-19-2002.
- 2,651,744. TELE-ROLLER. INT. CL. 16. (U.S. CLS. 2, 5, 22, 23, 29, 37, 38 AND 50). REG. 11-19-2002.
- 2,651,910. E.R. BRADLEY'S SALOON AND DESIGN. INT. CL. 43. (U.S. CLS. 100 AND 101). REG. 11-19-2002.
- 2,653,478. NEIGHBORHOOD IN A BOX. INT. CLS. 9, 16 AND 42. (U.S. CLS. 2, 5, 21, 22, 23, 26, 29, 36, 37, 38, 50, 100 AND 101). REG. 11-26-2002.
- 2,654,000. WHAT'LL WE THINK OF NEXT?. INT. CL. 9. (U.S. CLS. 21, 23, 26, 36 AND 38). REG. 11-26-2002.
- 2,656,073. SIGN IT QUICK. INT. CLS. 35 AND 42. (U.S. CLS. 100, 101 AND 102). REG. 12-3-2002.
- 2,656,764. MEBÓ. INT. CLS. 3 AND 5. (U.S. CLS. 1, 4, 6, 18, 44, 46, 50, 51 AND 52). REG. 12-3-2002.
- 2,657,448. COMPLETE COMPLIANCE. INT. CL. 42. (U.S. CLS. 100 AND 101). REG. 12-3-2002.
- 2,658,085. SHATTERTINE. INT. CL. 8. (U.S. CLS. 23, 28 AND 44). REG. 12-10-2002.
- 2,658,334. INFORMA TRAINING PARTNERS. INT. CL. 41. (U.S. CLS. 100, 101 AND 107). REG. 12-10-2002.
- 2,658,421. MED AMERICA FINANCIAL SERVICES, INC. AND DESIGN. INT. CL. 36. (U.S. CLS. 100, 101 AND 102). REG. 12-10-2002.
- 2,658,821. TRIROC. INT. CL. 9. (U.S. CLS. 21, 23, 26, 36 AND 38). REG. 12-10-2002.
- 2,659,305. CAPITAS. INT. CL. 36. (U.S. CLS. 100, 101 AND 102). REG. 12-10-2002.
- 2,659,310. CLASSIC TOUCH. INT. CL. 3 ONLY. (U.S. CLS. 1, 4, 6, 50, 51 AND 52). REG. 12-10-2002.
- 2,660,357. CAL. BERRIES. INT. CL. 25. (U.S. CLS. 22 AND 39). REG. 12-10-2002.
- 2,660,776. MISCELLANEOUS DESIGN. INT. CL. 42. (U.S. CLS. 100 AND 101). REG. 12-10-2002.
- 2,661,650. JEAH. INT. CL. 42. (U.S. CLS. 100 AND 101). REG. 12-17-2002.
- 2,661,706. LAUNCH PAD. INT. CL. 35. (U.S. CLS. 100, 101 AND 102). REG. 12-17-2002.
- 2,662,627. SANDWICH-TAINER. INT. CL. 16. (U.S. CLS. 2, 5, 22, 23, 29, 37, 38 AND 50). REG. 12-17-2002.
- 2,662,774. VACULET AND DESIGN. INT. CL. 10. (U.S. CLS. 26, 39 AND 44). REG. 12-17-2002.
- 2,662,826. NOVAFLOOR. INT. CL. 27. (U.S. CLS. 19, 20, 37, 42 AND 50). REG. 12-17-2002.
- 2,662,878. BESTLER AND DESIGN. INT. CL. 15. (U.S. CLS. 2, 21 AND 36). REG. 12-17-2002.
- 2,663,121. TWIN FORCE. INT. CL. 10. (U.S. CLS. 26, 39 AND 44). REG. 12-17-2002.
- 2,663,125. THE CLUB FOUNDATION AND DESIGN. INT. CL. 36. (U.S. CLS. 100, 101 AND 102). REG. 12-17-2002.
- 2,663,157. OUTTAKES (STYLIZED). INT. CL. 35. (U.S. CLS. 100, 101 AND 102). REG. 12-17-2002.
- 2,663,158. OUT TAKES. INT. CL. 35. (U.S. CLS. 100, 101 AND 102). REG. 12-17-2002.
- 2,663,251. WITH THE SEASONS. INT. CLS. 9 AND 16. (U.S. CLS. 2, 5, 21, 22, 23, 26, 29, 36, 37, 38 AND 50). REG. 12-17-2002.
- 2,663,375. VIBRACUSSOR. INT. CL. 10. (U.S. CLS. 26, 39 AND 44). REG. 12-17-2002.
- 2,663,391. PROBOARDS. INT. CL. 42. (U.S. CLS. 100 AND 101). REG. 12-17-2002.
- 2,663,496. HARDWEAR. INT. CL. 3. (U.S. CLS. 1, 4, 6, 50, 51 AND 52). REG. 12-17-2002.
- 2,663,537. MISCELLANEOUS DESIGN. INT. CL. 30. (U.S. CL. 46). REG. 12-17-2002.
- 2,663,857. MY LITTLE STEAMER. INT. CL. 9. (U.S. CLS. 21, 23, 26, 36 AND 38). REG. 12-17-2002.
- 2,664,052. SPIDER WEB. INT. CL. 30. (U.S. CL. 46). REG. 12-17-2002.
- 2,664,468. SUPER DUPER. INT. CL. 41. (U.S. CLS. 100, 101 AND 107). REG. 12-17-2002.
- 2,664,533. ARPM. INT. CL. 9. (U.S. CLS. 21, 23, 26, 36 AND 38). REG. 12-17-2002.
- 2,664,635. PC PEEKERS. INT. CL. 9. (U.S. CLS. 21, 23, 26, 36 AND 38). REG. 12-17-2002.
- 2,665,464. MAHR FEDERAL AND DESIGN. INT. CL. 9 ONLY. (U.S. CLS. 21, 23, 26, 36 AND 38). REG. 12-24-2002.
- 2,665,753. SOVERNET. INT. CLS. 38 AND 42. (U.S. CLS. 100, 101 AND 104). REG. 12-24-2002.
- 2,665,815. AMERICAN MINIATURE HORSE REGISTRY. INT. CL. 35. (U.S. CLS. 100, 101 AND 102). REG. 12-24-2002.
- 2,665,816. AMERICAN SHOW PONY. INT. CL. 35. (U.S. CLS. 100, 101 AND 102). REG. 12-24-2002.
- 2,665,817. AMERICAN SHETLAND PONY CLUB. INT. CL. 35. (U.S. CLS. 100, 101 AND 102). REG. 12-24-2002.
- 2,665,847. BRIDGE COTE. INT. CL. 2. (U.S. CLS. 6, 11 AND 16). REG. 12-24-2002.
- 2,666,050. VANKON AND DESIGN. INT. CL. 11. (U.S. CLS. 13, 21, 23, 31 AND 34). REG. 12-24-2002.
- 2,666,054. MISCELLANEOUS DESIGN. INT. CL. 16. (U.S. CLS. 2, 5, 22, 23, 29, 37, 38 AND 50). REG. 12-24-2002.
- 2,666,129. MISCELLANEOUS DESIGN. INT. CL. 19. (U.S. CLS. 1, 12, 33 AND 50). REG. 12-24-2002.
- 2,666,696. PHYTOCILLIN. INT. CL. 5. (U.S. CLS. 6, 18, 44, 46, 51 AND 52). REG. 12-24-2002.
- 2,667,044. NEWTOWN. INT. CL. 30. (U.S. CL. 46). REG. 12-24-2002.
- 2,667,172. AVAILITY. INT. CL. 42. (U.S. CLS. 100 AND 101). REG. 12-24-2002.
- 2,667,475. INTERACTIVE MALE. INT. CL. 42. (U.S. CLS. 100 AND 101). REG. 12-31-2002.
- 2,668,138. EARTH AND DESIGN. INT. CL. 25. (U.S. CLS. 22 AND 39). REG. 12-31-2002.
- 2,668,728. JAZZERCISE IT SHOWS. INT. CL. 41. (U.S. CLS. 100, 101 AND 107). REG. 12-31-2002.
- 2,668,959. DEFEASE WITH EASE. INT. CL. 36. (U.S. CLS. 100, 101 AND 102). REG. 12-31-2002.
- 2,669,082. TRUE FIT. INT. CL. 12. (U.S. CLS. 19, 21, 23, 31, 35 AND 44). REG. 12-31-2002.
- 2,669,126. DURACON AND DESIGN. INT. CL. 19. (U.S. CLS. 1, 12, 33 AND 50). REG. 12-31-2002.
- 2,669,520. TEX COTE STONE TEX AND DESIGN. INT. CL. 2. (U.S. CLS. 6, 11 AND 16). REG. 12-31-2002.
- 2,670,065. VIBELINE. INT. CL. 38. (U.S. CLS. 100, 101 AND 104). REG. 12-31-2002.
- 2,671,709. GUTSY WOMEN TRAVEL. INT. CLS. 39 AND 43. (U.S. CLS. 100, 101 AND 105). REG. 1-7-2003.
- 2,672,379. HERBAPROFEN. INT. CL. 5. (U.S. CLS. 6, 18, 44, 46, 51 AND 52). REG. 1-7-2003.

- | | |
|---|---|
| 2,673,807. SPARK SCHOOL PARK PROGRAM AND DESIGN. INT. CL. 41. (U.S. CLS. 100, 101 AND 107). REG. 1-14-2003. | 2,680,526. TEA 4LIFE. INT. CL. 5. (U.S. CLS. 6, 18, 44, 46, 51 AND 52). REG. 1-28-2003. |
| 2,676,753. PRESTIGE. INT. CL. 11. (U.S. CLS. 13, 21, 23, 31 AND 34). REG. 1-21-2003. | 2,681,423. MONAG. INT. CL. 25. (U.S. CLS. 22 AND 39). REG. 1-28-2003. |
| 2,678,478. FLUVAC INNOVATOR. INT. CL. 5. (U.S. CLS. 6, 18, 44, 46, 51 AND 52). REG. 1-21-2003. | 2,682,707. DURASAFE. INT. CLS. 6 AND 12. (U.S. CLS. 2, 12, 13, 14, 19, 21, 23, 25, 31, 35, 44 AND 50). REG. 2-4-2003. |
| 2,679,710. PRIMUS AND DESIGN. INT. CL. 38. (U.S. CLS. 100, 101 AND 104). REG. 1-28-2003. | 2,684,630. X-MART. INT. CL. 35. (U.S. CLS. 100, 101 AND 102). REG. 2-4-2003. |

* * * * *

TRADEMARK REGISTRATIONS CANCELED

The designation "U.S. Cl." appearing in this section refers to the U.S. class in effect prior to Sep. 1, 1973 rather than the international class which applies to applications filed on or after that date. For adoption of international classification see notice in the OFFICIAL GAZETTE of Jun. 26, 1973 (911 O.G. TM 210).

SECTION 7(D)

- 1,662,614. CALIFORNIA HI LITES. INT. CL. 29. REG. 10-29-1991.
- 3,116,637. NANNY GOAT VINEYARD STANDARD CHARACTER MARK. INT. CL. 33. REG. 7-18-2006.
- 3,288,183. SELECTREMEDY INTELLIGENT STAFFING. EXTRA-MILE SERVICE. STANDARD CHARACTER MARK. INT. CL. 35. REG. 9-4-2007.
- 3,437,359. MISCELLANEOUS DESIGN. INT. CL. 5. REG. 5-27-2008.
- 3,615,161. FOUR PLUS TWO: TALES FOR THE PET LOVER'S HEART STANDARD CHARACTER MARK. INT. CL. 41. REG. 5-5-2009.
- 3,645,485. JOE'S PIZZA OF BLEECKER STREET STANDARD CHARACTER MARK. INT. CL. 30. REG. 6-30-2009.
- 3,672,872. URBAN DOG DESIGNS STANDARD CHARACTER MARK. INT. CL. 18. REG. 8-25-2009.
- 4,021,809. US COACHWAYS AND DESIGN. INT. CL. 39. REG. 9-6-2011.
- 4,051,843. TREASURE HUNTERS ROADSHOW AND DESIGN. INT. CL. 41. REG. 11-8-2011.
- 4,051,844. TREASURE HUNTERS ROADSHOW AND DESIGN. INT. CL. 35. REG. 11-8-2011.
- 2,460,936. COGNIDYNE. INT. CL. 16 ONLY. REG. 6-19-2001.
- 2,465,743. BLACK-T. INT. CL. 2. REG. 7-3-2001.
- 2,466,814. METRO. INT. CLS. 11, 20 AND 21. REG. 7-10-2001.
- 2,466,843. BOWMAN DESIGN AND DESIGN. INT. CL. 42. REG. 7-10-2001.
- 2,466,844. TECA. INT. CL. 10. REG. 7-10-2001.
- 2,466,849. CALM. INT. CL. 9. REG. 7-10-2001.
- 2,466,851. PHANTOM COACHES HEARSE CLUB AND DESIGN. INT. CL. 42. REG. 7-10-2001.
- 2,466,856. THE AEGIS SERVING HARFORD COUNTY AND DESIGN. INT. CL. 16. REG. 7-10-2001.
- 2,466,859. CORPORATE INTERCONNECT. INT. CL. 9. REG. 7-10-2001.
- 2,466,862. MISCELLANEOUS DESIGN. INT. CL. 20. REG. 7-10-2001.
- 2,466,865. JUST-IN-TIME LEARNING. INT. CL. 42. REG. 7-10-2001.
- 2,466,899. TANNEN BOMB. INT. CL. 32. REG. 7-10-2001.
- 2,466,904. BARNABY. INT. CL. 28. REG. 7-10-2001.
- 2,466,907. SLAB DIP. INT. CL. 1. REG. 7-10-2001.
- 2,466,911. UNIDRYER. INT. CL. 11. REG. 7-10-2001.
- 2,466,919. BLUE SKY. INT. CL. 35. REG. 7-10-2001.
- 2,466,922. FOR THE WATER IN YOUR LIFE. INT. CL. 35. REG. 7-10-2001.
- 2,466,928. NORTH AMERICA RAIL PASS AMTRAK/VIA AND DESIGN. INT. CL. 39. REG. 7-10-2001.
- 2,466,941. DIMBY AND DESIGN. INT. CL. 41. REG. 7-10-2001.
- 2,466,942. FIC. INT. CL. 36. REG. 7-10-2001.
- 2,466,943. FIC (STYLIZED). INT. CL. 36. REG. 7-10-2001.
- 2,466,947. WESTERN OUTDOORS. INT. CL. 16. REG. 7-10-2001.
- 2,466,948. MISCELLANEOUS DESIGN. INT. CL. 3. REG. 7-10-2001.
- 2,466,952. PARKSIDE. INT. CL. 37. REG. 7-10-2001.
- 2,466,953. RAIFIX. INT. CL. 1. REG. 7-10-2001.
- 2,466,956. PIMP 'N HO. INT. CL. 41. REG. 7-10-2001.
- 2,466,965. SLEEP GALLERY AND DESIGN. INT. CL. 35. REG. 7-10-2001.
- 2,466,970. BRAIN MANAGEMENT (STYLIZED). INT. CL. 16. REG. 7-10-2001.
- 2,466,985. ROCK-A-BUDDIES. INT. CL. 19. REG. 7-10-2001.
- 2,466,994. BC ESCAPES. INT. CLS. 39, 41 AND 42. REG. 7-10-2001.
- 2,467,003. HYDROFEEL. INT. CL. 1. REG. 7-10-2001.
- 2,467,007. BONNIE PINK. INT. CL. 25. REG. 7-10-2001.
- 2,467,008. SEACOASTER. INT. CL. 12. REG. 7-10-2001.
- 2,467,009. COLLINGTON (STYLIZED). INT. CL. 42. REG. 7-10-2001.
- 2,467,010. BREEZE. INT. CL. 30. REG. 7-10-2001.
- 2,467,012. MICROGEL. INT. CL. 1. REG. 7-10-2001.
- 2,467,015. POWER GLOSS. INT. CL. 3. REG. 7-10-2001.
- 2,467,022. I.D. MATE AND DESIGN. INT. CL. 9. REG. 7-10-2001.
- 2,467,023. CERAMIDIZE. INT. CL. 40. REG. 7-10-2001.
- 2,467,033. THE LEATHERWOOD COLLECTION AND DESIGN. INT. CL. 3. REG. 7-10-2001.
- 2,467,049. MAGNOFLEX. INT. CL. 10. REG. 7-10-2001.
- 2,467,070. DELPHI. INT. CL. 42. REG. 7-10-2001.
- 2,467,074. LIVEIQUE. INT. CL. 9. REG. 7-10-2001.
- 2,467,077. EDISH. INT. CL. 35. REG. 7-10-2001.
- 2,467,081. A DISCIPLINED LIFE. INT. CL. 41. REG. 7-10-2001.

SECTION 8

- 537,680. MISCELLANEOUS DESIGN. U.S. CL. 46. REG. 2-13-1951.
- 1,071,952. UNITED OVERSEAS BANK. INT. CL. 36. REG. 8-23-1977.
- 1,149,780. BOOKS OF THE TIMES. INT. CL. 16. REG. 3-31-1981.
- 1,152,587. EMPEROR'S CHOICE. INT. CL. 30. REG. 4-28-1981.
- 1,160,674. STIEFF. INT. CLS. 8, 20 AND 21. REG. 7-14-1981.
- 1,183,583. BANCTEC. INT. CL. 16 ONLY. REG. 12-29-1981.
- 1,184,290. VERSAR. INT. CLS. 1, 6, 9, 17 AND 40 ONLY. REG. 1-5-1982.
- 1,184,733. RED1. INT. CLS. 16 AND 31 ONLY. REG. 1-5-1982.
- 1,529,949. HARVEST CHOICE. INT. CL. 32. REG. 3-14-1989.
- 1,624,182. SLICE!SLICE!. INT. CL. 42. REG. 11-20-1990.
- 1,643,862. FIRST SECURITY BANK. INT. CL. 36. REG. 5-7-1991.
- 1,649,005. FIRST SECURITY. INT. CL. 36. REG. 6-25-1991.
- 2,078,947. MW AND DESIGN. INT. CL. 41. REG. 7-15-1997.
- 2,322,686. ISAAC AND DESIGN. INT. CL. 25. REG. 2-29-2000.
- 2,358,670. RIVER BEND LINKS. INT. CL. 16. REG. 6-13-2000.
- 2,374,576. CALIFORNIA SAFETY TRAINING CORPORATION. INT. CL. 41. REG. 8-8-2000.
- 2,393,273. HUMAN FORM. INT. CL. 35. REG. 10-10-2000.
- 2,423,614. HYDROSHIELD. INT. CL. 17. REG. 1-23-2001.
- 2,425,661. TIGER WIND. INT. CL. 28. REG. 1-30-2001.
- 2,458,844. ASSOCIATION OF DIVORCE ATTORNEYS FOR MEN. INT. CL. 42. REG. 6-5-2001.

- 2,467,091. YOUR BANK. YOUR WAY.. INT. CL. 36. REG. 7-10-2001.
- 2,467,095. READYCAL. INT. CLS. 1 AND 9. REG. 7-10-2001.
- 2,467,109. THE CONSECO EDGE. INT. CL. 16. REG. 7-10-2001.
- 2,467,112. BFAST. INT. CLS. 9 AND 35. REG. 7-10-2001.
- 2,467,115. UNIVERSALACCESS. INT. CL. 38. REG. 7-10-2001.
- 2,467,118. COOL JAY'S. INT. CL. 34. REG. 7-10-2001.
- 2,467,133. ACCU-LINER. INT. CL. 10. REG. 7-10-2001.
- 2,467,137. BALFOUR RETIREMENT COMMUNITY AND DESIGN. INT. CL. 42. REG. 7-10-2001.
- 2,467,141. ERGO. INT. CL. 10. REG. 7-10-2001.
- 2,467,158. ORECK. INT. CL. 1. REG. 7-10-2001.
- 2,467,178. AQUAPAD. INT. CL. 25. REG. 7-10-2001.
- 2,467,183. CINEMA GRILL AND DESIGN. INT. CLS. 41 AND 42. REG. 7-10-2001.
- 2,467,200. OYAMA AGARICUS. INT. CL. 29. REG. 7-10-2001.
- 2,467,231. CPA AND DESIGN. INT. CL. 36. REG. 7-10-2001.
- 2,467,235. GOOD LUCK RANCH AND DESIGN. INT. CL. 18. REG. 7-10-2001.
- 2,467,255. DON'T WAX BONE WITHOUT IT. INT. CL. 10. REG. 7-10-2001.
- 2,467,258. PIZZ@WORK AND DESIGN. INT. CL. 39. REG. 7-10-2001.
- 2,467,261. BOTANICA. INT. CL. 32. REG. 7-10-2001.
- 2,467,270. FORMULA 1. INT. CL. 31. REG. 7-10-2001.
- 2,467,271. CARDS USA AND DESIGN. INT. CL. 42. REG. 7-10-2001.
- 2,467,278. EXCEL CUSTOM. INT. CL. 36. REG. 7-10-2001.
- 2,467,284. GLIMMER GELS. INT. CL. 16. REG. 7-10-2001.
- 2,467,296. SPENCER F. KATT: RUMOR CENTRAL. INT. CL. 16. REG. 7-10-2001.
- 2,467,305. SAGA BABY BLUE. INT. CL. 29. REG. 7-10-2001.
- 2,467,320. TRANSFAIR TRANSGROUP. INT. CL. 39. REG. 7-10-2001.
- 2,467,322. HARRY'S ARMY & NAVY. INT. CL. 35. REG. 7-10-2001.
- 2,467,331. WESTATES AND DESIGN. INT. CLS. 9, 12 AND 37. REG. 7-10-2001.
- 2,467,332. A LIFE WORTH LIVING IS A LIFE WORTH REMEMBERING. INT. CL. 42. REG. 7-10-2001.
- 2,467,337. SEAVA. INT. CL. 9. REG. 7-10-2001.
- 2,467,342. BIG FIGHTS. INT. CL. 41. REG. 7-10-2001.
- 2,467,346. R.W. MARTIN & SONS. INC. AUTOMATED LAUNDRY SYSTEMS AND DESIGN. INT. CLS. 35, 37 AND 42. REG. 7-10-2001.
- 2,467,349. LOCH LOMOND GOLF CLUB AND DESIGN. INT. CLS. 25 AND 28. REG. 7-10-2001.
- 2,467,361. VALENTINE'S GOURMET COFFEE & ICE CREAM AND DESIGN. INT. CL. 42. REG. 7-10-2001.
- 2,467,362. IDEUM AND DESIGN. INT. CL. 42. REG. 7-10-2001.
- 2,467,365. PELUCHES. INT. CL. 16. REG. 7-10-2001.
- 2,467,368. THURSTY THE ELEPHANT. INT. CL. 9. REG. 7-10-2001.
- 2,467,372. HUGS BY PAT. INT. CL. 28. REG. 7-10-2001.
- 2,467,375. WHITE GENIE. INT. CL. 3. REG. 7-10-2001.
- 2,467,378. QUIN TANGO (STYLIZED). INT. CL. 41. REG. 7-10-2001.
- 2,467,392. AMARIN 100. INT. CLS. 29 AND 30. REG. 7-10-2001.
- 2,467,395. RIPKEN BASEBALL AND DESIGN. INT. CL. 41. REG. 7-10-2001.
- 2,467,412. REGATTA BAY MARKETPLACE AND DESIGN. INT. CL. 36. REG. 7-10-2001.
- 2,467,419. BUTTON IN EAR. INT. CL. 25. REG. 7-10-2001.
- 2,467,420. VETCONNECT AND DESIGN. INT. CLS. 35 AND 42. REG. 7-10-2001.
- 2,467,422. CASEONE (STYLIZED). INT. CLS. 36 AND 42. REG. 7-10-2001.
- 2,467,430. TOUCH BOY AND DESIGN. INT. CLS. 9 AND 28. REG. 7-10-2001.
- 2,467,441. SETTON FARMS AND DESIGN. INT. CLS. 29, 30 AND 31. REG. 7-10-2001.
- 2,467,452. BACKDRAFT. INT. CL. 5. REG. 7-10-2001.
- 2,467,459. U.S. AIRFORCE EXPERIENCE AND DESIGN. INT. CLS. 35 AND 42. REG. 7-10-2001.
- 2,467,489. GOOD MEDICINE FOR GOOD CHOLESTEROL. INT. CL. 5. REG. 7-10-2001.
- 2,467,502. POWERMAX. INT. CLS. 4 AND 11. REG. 7-10-2001.
- 2,467,506. CHURCH OF THE SECOND ADVENT. INT. CLS. 16, 41 AND 42. REG. 7-10-2001.
- 2,467,511. CHICKEN FAT. INT. CL. 9. REG. 7-10-2001.
- 2,467,517. MISCELLANEOUS DESIGN. INT. CL. 35. REG. 7-10-2001.
- 2,467,518. PROPEL AND DESIGN. INT. CL. 42. REG. 7-10-2001.
- 2,467,525. FLEXICUENTA. INT. CL. 36. REG. 7-10-2001.
- 2,467,537. JUSTINE BATEMAN. INT. CL. 25. REG. 7-10-2001.
- 2,467,545. STUDIO360. INT. CL. 42. REG. 7-10-2001.
- 2,467,549. CINAHLNEWS. INT. CL. 16. REG. 7-10-2001.
- 2,467,555. JOBSTHATFIT.. INT. CL. 35. REG. 7-10-2001.
- 2,467,567. SURFMASTERS. INT. CL. 42. REG. 7-10-2001.
- 2,467,580. PROJECT MIND MATH IS NOT DIFFICULT AND DESIGN. INT. CLS. 16 AND 41. REG. 7-10-2001.
- 2,467,581. QUATTRO ULTIMA. INT. CL. 9. REG. 7-10-2001.
- 2,467,583. NHRA HEAT AND DESIGN. INT. CL. 41. REG. 7-10-2001.
- 2,467,600. FALL PROTECTION. INT. CL. 16. REG. 7-10-2001.
- 2,467,611. CINEVEGAS. INT. CL. 41. REG. 7-10-2001.
- 2,467,615. PLOTMASTER. INT. CL. 7. REG. 7-10-2001.
- 2,467,623. BRADLEY TELETHEATER. INT. CL. 41. REG. 7-10-2001.
- 2,467,624. RACEVIEW. INT. CL. 41. REG. 7-10-2001.
- 2,467,626. V AND DESIGN. INT. CL. 42. REG. 7-10-2001.
- 2,467,638. MISCELLANEOUS DESIGN. INT. CL. 41. REG. 7-10-2001.
- 2,467,648. BUD & IVY. INT. CL. 28. REG. 7-10-2001.
- 2,467,649. HUDSON & MCCOY. INT. CL. 42. REG. 7-10-2001.
- 2,467,660. MISCELLANEOUS DESIGN. INT. CL. 36. REG. 7-10-2001.
- 2,467,677. RESINBRITE. INT. CL. 3. REG. 7-10-2001.
- 2,467,681. SOF-TWO. INT. CL. 1. REG. 7-10-2001.
- 2,467,686. BIOPARTIAL. INT. CL. 10. REG. 7-10-2001.
- 2,467,687. SEEING SPOTS. INT. CL. 25. REG. 7-10-2001.
- 2,467,689. ECOSCIENCE. INT. CL. 42. REG. 7-10-2001.
- 2,467,691. STORE A BOARD. INT. CL. 21. REG. 7-10-2001.
- 2,467,693. PASTELANDIA AND DESIGN. INT. CL. 42. REG. 7-10-2001.
- 2,467,703. COMPLETE BODY. INT. CL. 41. REG. 7-10-2001.
- 2,467,704. DESIGNS PLUS. INT. CL. 21. REG. 7-10-2001.
- 2,467,713. OPENWORKS AND DESIGN. INT. CL. 37. REG. 7-10-2001.
- 2,467,716. FROM FISHING LINE TO BOTTOM LINE. INT. CL. 35. REG. 7-10-2001.
- 2,467,717. GAI MATTIOLO. INT. CL. 3. REG. 7-10-2001.
- 2,467,729. JOSHUA FORCE IMPACTING THIS GENERATION FOR JESUS-CHANGING OUR WORLD-IMPACTING THIS GENERATION FOR JESUS AND DESIGN. INT. CL. 41. REG. 7-10-2001.
- 2,467,737. LEVEL100 COMMUNICATIONS. INT. CL. 42. REG. 7-10-2001.
- 2,467,742. SUMMIT SECUREONLINE. INT. CL. 36. REG. 7-10-2001.
- 2,467,746. ADVANTAGE. INT. CL. 10. REG. 7-10-2001.
- 2,467,779. PRO SYSTEM. INT. CLS. 7 AND 40. REG. 7-10-2001.
- 2,467,781. FORCE 5 AND DESIGN. INT. CL. 7. REG. 7-10-2001.
- 2,467,787. THE CLUB SECURITY SERIES. INT. CL. 6. REG. 7-10-2001.
- 2,467,794. CHIPSTRIP. INT. CL. 9. REG. 7-10-2001.
- 2,467,798. ESSAYS ON VALUES. INT. CL. 16. REG. 7-10-2001.
- 2,467,803. AGUA HOME. INT. CL. 3. REG. 7-10-2001.
- 2,467,809. INWELL. INT. CL. 37. REG. 7-10-2001.
- 2,467,811. EPIVAX AND DESIGN. INT. CL. 42. REG. 7-10-2001.
- 2,467,814. ADVANCE MODULES. INT. CL. 9. REG. 7-10-2001.

- 2,467,818. ADCO INC. QUALITY INTEGRITY & DEPENDABILITY SINCE 1908 ADCO QUALITY TALKS! AND DESIGN. INT. CL. 3. REG. 7-10-2001.
- 2,467,825. MISCELLANEOUS DESIGN. INT. CL. 42. REG. 7-10-2001.
- 2,467,835. K.SWISS (STYLIZED). INT. CL. 9. REG. 7-10-2001.
- 2,467,843. SPORTING GOODS INTELLIGENCE. INT. CL. 16. REG. 7-10-2001.
- 2,467,853. DX DESIGN XPRESS (STYLIZED). INT. CL. 35. REG. 7-10-2001.
- 2,467,857. CONCEPT SHOPPING AND DESIGN. INT. CL. 35. REG. 7-10-2001.
- 2,467,864. GALLERY ECLECTIC. INT. CL. 35. REG. 7-10-2001.
- 2,467,870. WE ALSO TREAT THE HUMAN SPIRIT.. INT. CL. 42. REG. 7-10-2001.
- 2,467,890. INTERVIEWRIGHT. INT. CL. 9. REG. 7-10-2001.
- 2,467,904. IOTA SOLUTIONS. INT. CL. 42. REG. 7-10-2001.
- 2,467,906. ASK THE GIFT GURU. INT. CL. 35. REG. 7-10-2001.
- 2,467,911. SANDRA KING. INT. CL. 25. REG. 7-10-2001.
- 2,467,914. SPIRIT OF HEALING. INT. CL. 5. REG. 7-10-2001.
- 2,467,921. COCA-COLA. INT. CL. 9. REG. 7-10-2001.
- 2,467,939. THE HR TEAM. INT. CL. 35. REG. 7-10-2001.
- 2,467,952. ULTRACORR. INT. CL. 2. REG. 7-10-2001.
- 2,467,972. TRANSPOTTER. INT. CL. 8. REG. 7-10-2001.
- 2,467,977. NO RODEO. INT. CL. 16. REG. 7-10-2001.
- 2,467,981. ELEGANT WEDDING. INT. CL. 16. REG. 7-10-2001.
- 2,467,989. FNAL. INT. CL. 41. REG. 7-10-2001.
- 2,468,001. NEW VISIONS AND DESIGN. INT. CLS. 16 AND 41. REG. 7-10-2001.
- 2,468,002. ROL-OUT. INT. CL. 16. REG. 7-10-2001.
- 2,468,005. SMOKEY. INT. CL. 16. REG. 7-10-2001.
- 2,468,007. ALWAYS GREENER. INT. CL. 16. REG. 7-10-2001.
- 2,468,008. PINKLY. INT. CL. 16. REG. 7-10-2001.
- 2,468,010. CREAMEDIC. INT. CL. 3. REG. 7-10-2001.
- 2,468,012. MISCELLANEOUS DESIGN. INT. CL. 4. REG. 7-10-2001.
- 2,468,033. POST-GAZETTE.COM AND DESIGN. INT. CL. 42. REG. 7-10-2001.
- 2,468,043. GROUNDFORCE. INT. CLS. 21 AND 37. REG. 7-10-2001.
- 2,468,046. AMORE (STYLIZED). INT. CL. 3. REG. 7-10-2001.
- 2,468,054. BEER TWISTER. INT. CL. 30. REG. 7-10-2001.
- 2,468,061. AGILE SHIP AND DESIGN. INT. CL. 9. REG. 7-10-2001.
- 2,468,068. *HELIX AND DESIGN. INT. CL. 9. REG. 7-10-2001.
- 2,468,075. ARY AND DESIGN. INT. CL. 14. REG. 7-10-2001.
- 2,468,096. APPLIED MEDIA OUTPATIENT AND DESIGN. INT. CL. 9. REG. 7-10-2001.
- 2,468,100. BIKERDOG. INT. CL. 12. REG. 7-10-2001.
- 2,468,105. DAVTR. INT. CL. 9. REG. 7-10-2001.
- 2,468,116. HUGO REITZEL AND DESIGN. INT. CL. 29. REG. 7-10-2001.
- 2,468,120. UNIVERSAL STUDIOS VACATIONS. INT. CL. 39. REG. 7-10-2001.
- 2,468,126. DELSTAR. INT. CLS. 9 AND 16. REG. 7-10-2001.
- 2,468,135. GREAT PYRAMID PASSPORT. INT. CL. 41. REG. 7-10-2001.
- 2,468,145. CAMP COOLEY RANCH. INT. CLS. 5 AND 31. REG. 7-10-2001.
- 2,468,148. TRAVEL SECRET. INT. CLS. 39 AND 42. REG. 7-10-2001.
- 2,468,155. DERMAVITE. INT. CL. 5. REG. 7-10-2001.
- 2,468,161. CLEAR PASSAGE THERAPIES AND DESIGN. INT. CL. 42. REG. 7-10-2001.
- 2,468,164. TEXAS MONTHLY BIZ. INT. CL. 16. REG. 7-10-2001.
- 2,468,202. DETECHTIVE (STYLIZED). INT. CL. 9. REG. 7-10-2001.
- 2,468,204. SIGNALPLEX. INT. CL. 9. REG. 7-10-2001.
- 2,468,206. MAGNI-CHEK (STYLIZED). INT. CL. 11. REG. 7-10-2001.
- 2,468,208. RR AND DESIGN. INT. CLS. 24, 25, 28, 37 AND 41. REG. 7-10-2001.
- 2,468,232. THERALACTIN. INT. CL. 3. REG. 7-10-2001.
- 2,468,235. TEQ. INT. CL. 36. REG. 7-10-2001.
- 2,468,239. PARK FLIGHT. INT. CL. 42. REG. 7-10-2001.
- 2,468,246. PRACTICE BUILDER 123. INT. CLS. 9 AND 42. REG. 7-10-2001.
- 2,468,249. FIT CHOP. INT. CL. 7. REG. 7-10-2001.
- 2,468,250. MYNTZ! (STYLIZED). INT. CL. 30. REG. 7-10-2001.
- 2,468,259. ISLATROL ELITE. INT. CL. 9. REG. 7-10-2001.
- 2,468,271. FASTFUTURE. INT. CL. 9. REG. 7-10-2001.
- 2,468,288. PLAY FROM YOUR SEAT. INT. CL. 21. REG. 7-10-2001.
- 2,468,291. @NEWORLD. INT. CL. 9. REG. 7-10-2001.
- 2,468,305. CBACK AND DESIGN. INT. CL. 9. REG. 7-10-2001.
- 2,468,309. WE MAKE COMPANIES FAST. INT. CL. 35. REG. 7-10-2001.
- 2,468,312. BEWILDERBEAST. INT. CL. 28. REG. 7-10-2001.
- 2,468,333. BRIDGE EMPLOYER. INT. CLS. 35 AND 42. REG. 7-10-2001.
- 2,468,357. PARTNERS IN PURSUIT OF POLLUTION PREVENTION. INT. CL. 42. REG. 7-10-2001.
- 2,468,362. MISCELLANEOUS DESIGN. INT. CL. 25. REG. 7-10-2001.
- 2,468,394. INSTANT REPLAY. INT. CL. 16. REG. 7-10-2001.
- 2,468,395. SANDBOX.COM. INT. CL. 41. REG. 7-10-2001.
- 2,468,398. PRIMEX TRADING AND DESIGN. INT. CL. 9. REG. 7-10-2001.
- 2,468,403. OLD TOWN CLOVIS AND DESIGN. INT. CL. 42. REG. 7-10-2001.
- 2,468,404. MOVERS & SHAKERS (STYLIZED). INT. CL. 9. REG. 7-10-2001.
- 2,468,411. PHYLOGENETIC DESIGN. INT. CL. 35. REG. 7-10-2001.
- 2,468,413. ARTIFACT. INT. CL. 28. REG. 7-10-2001.
- 2,468,414. PLAYMAKERS AND DESIGN. INT. CL. 42. REG. 7-10-2001.
- 2,468,439. ROADGLIDER. INT. CL. 28. REG. 7-10-2001.
- 2,468,442. NAHQ NATIONAL ASSOCIATION FOR HEALTHCARE QUALITY AND DESIGN. INT. CL. 42. REG. 7-10-2001.
- 2,468,446. DELINEAR. INT. CL. 42. REG. 7-10-2001.
- 2,468,450. GUITAR ACADEMY AND DESIGN. INT. CL. 41. REG. 7-10-2001.
- 2,468,456. ALL TERRAIN PAIN. INT. CL. 28. REG. 7-10-2001.
- 2,468,459. BUTTONLOCK. INT. CL. 16. REG. 7-10-2001.
- 2,468,460. POWER OF FAITH. INT. CL. 14. REG. 7-10-2001.
- 2,468,465. WAVEFIX. INT. CL. 9. REG. 7-10-2001.
- 2,468,468. APPELLATION AND DESIGN. INT. CL. 3. REG. 7-10-2001.
- 2,468,473. DIRT-BE-GONE. INT. CL. 25. REG. 7-10-2001.
- 2,468,489. RE-USE-A-(L)ABEL AND DESIGN. INT. CL. 16. REG. 7-10-2001.
- 2,468,492. ASKCOUNSEL. INT. CL. 42. REG. 7-10-2001.
- 2,468,499. PHYSIONOMICS. INT. CL. 42. REG. 7-10-2001.
- 2,468,506. MISCELLANEOUS DESIGN. INT. CL. 2. REG. 7-10-2001.
- 2,468,508. WE&T. INT. CL. 16. REG. 7-10-2001.
- 2,468,521. LIGHTSCRIBE. INT. CL. 42. REG. 7-10-2001.
- 2,468,523. ORION. INT. CL. 9. REG. 7-10-2001.
- 2,468,524. MANAGING TODAY'S ASSETS, RECOVERING YESTERDAY'S LOSSES. INT. CL. 36. REG. 7-10-2001.
- 2,468,527. MISCELLANEOUS DESIGN. INT. CL. 11. REG. 7-10-2001.
- 2,468,528. ADVANCED PERFORMANCE SYSTEM. INT. CL. 28. REG. 7-10-2001.
- 2,468,536. WISDOM IN BUSINESS. INT. CL. 41. REG. 7-10-2001.
- 2,468,538. DRIFT CREEK. INT. CL. 22. REG. 7-10-2001.
- 2,468,563. 3DLINX. INT. CL. 9. REG. 7-10-2001.
- 2,468,571. DIGEST OF HOMES MORTGAGES & PROPERTY. INT. CL. 16. REG. 7-10-2001.
- 2,468,577. EMERGENCY ESSENTIALS. INT. CL. 29. REG. 7-10-2001.
- 2,468,579. CLAIMSDIRECT. INT. CL. 9. REG. 7-10-2001.
- 2,468,587. INSPECTION & CONTROL SERVICES. INT. CL. 42. REG. 7-10-2001.
- 2,468,588. BEACH GLASS. INT. CL. 19. REG. 7-10-2001.

- 2,468,599. THE TOTAL FACILITY MANAGEMENT EVENT. INT. CL. 35. REG. 7-10-2001.
- 2,468,605. BIOTEST. INT. CL. 16. REG. 7-10-2001.
- 2,470,018. FLEXSHAKE. INT. CL. 19. REG. 7-17-2001.
- 2,471,533. FAIRYGODMOTHER. INT. CL. 42. REG. 7-24-2001.
- 2,476,615. RPCPA REUSABLE PLASTIC CONTAINER & PALLET ASSOCIATION AND DESIGN. INT. CL. 42. REG. 8-7-2001.
- 2,483,486. MODERN LIVING. INT. CL. 27 ONLY. REG. 8-28-2001.
- 2,526,305. THE BROADWAY JUNIOR COLLECTION AND DESIGN. INT. CL. 42 ONLY. REG. 1-1-2002.
- 2,529,344. HAPPYLAWYERS.COM WE MAKE LAWYERS HAPPY. INT. CL. 35. REG. 1-15-2002.
- 2,533,624. LFI TITANIUMPLUS. INT. CL. 2. REG. 1-29-2002.
- 2,538,750. PAUL REVERE SILVERSMITHS. INT. CL. 21 ONLY. REG. 2-19-2002.
- 2,539,371. IF AND DESIGN. INT. CL. 35 ONLY. REG. 2-19-2002.
- 2,541,088. SWISS-SHIELD. INT. CLS. 9 AND 27 ONLY. REG. 2-19-2002.
- 2,541,868. DIAMONDS ON A WIRE. INT. CLS. 35 AND 40 ONLY. REG. 2-19-2002.
- 2,585,463. IG THE IGNEOUS GROUP, INC. AND DESIGN. INT. CL. 42. REG. 6-25-2002.
- 2,593,176. UNTANGLER. INT. CL. 10. REG. 7-9-2002.
- 2,602,317. UNCOMMON PRINTERS. INT. CL. 42. REG. 7-30-2002.
- 2,617,073. SOILING SOLUTIONS AND DESIGN. INT. CL. 42 ONLY. REG. 9-10-2002.
- 2,621,534. JUNIPER BREEZE. INT. CL. 11 ONLY. REG. 9-17-2002.
- 2,633,487. KENNEDY. INT. CL. 21 ONLY. REG. 10-8-2002.
- 2,659,310. CLASSIC TOUCH. INT. CL. 16 ONLY. REG. 12-10-2002.
- 2,670,148. T-RIBS. INT. CL. 29. REG. 12-31-2002.
- 2,686,012. LABOREXPERT AND DESIGN. INT. CL. 9. REG. 2-11-2003.
- 2,707,550. WHAT'S UP. INT. CL. 28. REG. 4-15-2003.
- 2,730,963. WISDOM. INT. CL. 38. REG. 7-1-2003.
- 2,737,304. DROP-INS. INT. CL. 20. REG. 7-15-2003.
- 2,750,876. IMAGE-EDIT. INT. CL. 42. REG. 8-12-2003.
- 2,762,712. ASOMBROSO. INT. CL. 33. REG. 9-9-2003.
- 2,774,451. EBULLION. INT. CL. 36. REG. 10-21-2003.
- 2,779,561. MISCELLANEOUS DESIGN. INT. CL. 35. REG. 11-4-2003.
- 2,783,617. FREEPLAY AND DESIGN. INT. CLS. 7, 8, 9, 11 AND 28. REG. 11-18-2003.
- 2,801,996. HEPLOGIC AND DESIGN. INT. CL. 44. REG. 1-6-2004.
- 2,804,384. RALOGIC AND DESIGN. INT. CL. 44. REG. 1-13-2004.
- 2,804,385. MSLOGIC AND DESIGN. INT. CL. 44. REG. 1-13-2004.
- 2,804,386. RSVLOGIC AND DESIGN. INT. CL. 44. REG. 1-13-2004.
- 2,811,170. YORSAN AND DESIGN. INT. CLS. 29 AND 32. REG. 2-3-2004.
- 2,822,903. JESUS HAS LEFT THE BUILDING AND WE'RE FOLLOWING HIM. INT. CL. 45. REG. 3-16-2004.
- 2,832,850. FARM TO TABLE. INT. CL. 29. REG. 4-13-2004.
- 2,833,622. PORT OF PORT ST. JOE AND DESIGN. INT. CL. 39. REG. 4-20-2004.
- 2,833,864. NATURITALLY. INT. CL. 33. REG. 4-20-2004.
- 2,836,381. MOVING MEDITATION. INT. CL. 41. REG. 4-27-2004.
- 2,840,394. EARTHSAVE. INT. CL. 16. REG. 5-11-2004.
- 2,845,269. FUTURE AND DESIGN. INT. CL. 38. REG. 5-25-2004.
- 2,855,354. SEVI KAY (STYLIZED). INT. CL. 3. REG. 6-15-2004.
- 2,868,919. OVANA. INT. CL. 14. REG. 8-3-2004.
- 2,874,476. SKYBED. INT. CL. 12. REG. 8-17-2004.
- 2,876,665. VISION BINDER. INT. CL. 35. REG. 8-24-2004.
- 2,879,372. CELES KING. INT. CL. 36. REG. 8-31-2004.
- 2,882,829. AMERICAN-SOCIETY OF QUESTIONED-DOCUMENT-EXAMINERS - JUSTICE THROUGH SCIENCE 1942 AND DESIGN. INT. CL. 41. REG. 9-7-2004.
- 2,885,999. FINE PAINTS. INT. CL. 2. REG. 9-21-2004.
- 2,891,440. CROWD!. INT. CL. 9. REG. 10-5-2004.
- 2,893,704. FEMINA. INT. CL. 28. REG. 10-12-2004.
- 2,894,773. SOUTHERN CALIFORNIA MINORITY BUSINESS DEVELOPMENT COUNCIL, INC. AND DESIGN. INT. CL. 41. REG. 10-19-2004.
- 2,898,687. BROKERAGE GROUP INTERNATIONAL, LLC AND DESIGN. INT. CL. 36. REG. 11-2-2004.
- 2,899,593. CELES KING III. INT. CL. 36. REG. 11-2-2004.
- 2,907,106. SKILLCUBE. INT. CL. 9. REG. 11-30-2004.
- 2,907,872. CATHOLIC MIGRATION SERVICES OF QUEENS AND DESIGN. INT. CL. 42. REG. 12-7-2004.
- 2,908,984. TERREL H. BELL AND ASSOCIATES STANDARD CHARACTER MARK. INT. CL. 41. REG. 12-7-2004.
- 2,910,004. REAL FI AND DESIGN. INT. CL. 36. REG. 12-14-2004.
- 2,911,353. BODY PRINCIPLE. INT. CL. 41 ONLY. REG. 12-14-2004.
- 2,912,421. NPCI AND DESIGN. INT. CL. 16. REG. 12-21-2004.
- 2,919,027. SEAGULL BOOK STANDARD CHARACTER MARK. INT. CL. 35. REG. 1-18-2005.
- 2,923,024. TASTE WASHINGTON STANDARD CHARACTER MARK. INT. CLS. 35 AND 41. REG. 2-1-2005.
- 2,923,178. MISTERCORN STANDARD CHARACTER MARK. INT. CLS. 29 AND 30. REG. 2-1-2005.
- 2,925,179. M AND DESIGN. INT. CL. 36. REG. 2-8-2005.
- 2,926,911. SONIC PRIMETIME. INT. CL. 9. REG. 2-15-2005.
- 2,932,284. REAKT STANDARD CHARACTER MARK. INT. CL. 25. REG. 3-15-2005.
- 2,934,404. SOCK IT TO' EM!. INT. CL. 25. REG. 3-22-2005.
- 2,935,243. PARAMOUNT TECHNOLOGY GROUP, INC. AND DESIGN. INT. CL. 42. REG. 3-22-2005.
- 2,941,883. MISCELLANEOUS DESIGN. INT. CL. 36. REG. 4-19-2005.
- 2,941,897. TOPSEAL STANDARD CHARACTER MARK. INT. CL. 1. REG. 4-19-2005.
- 2,946,117. NETRADIO AND DESIGN. INT. CL. 9. REG. 5-3-2005.
- 2,947,688. LIVE LOVE LAUGH. INT. CL. 25. REG. 5-10-2005.
- 2,955,824. SPORTS PICK. INT. CLS. 35 AND 41. REG. 5-24-2005.
- 2,959,482. TELECOM VENTURE GROUP. INT. CL. 36. REG. 6-7-2005.
- 2,959,579. NOVA STANDARD CHARACTER MARK. INT. CLS. 9 AND 42. REG. 6-7-2005.
- 2,965,413. TRILOGY INTERNATIONAL. INT. CL. 42. REG. 7-12-2005.
- 2,965,417. DIGICAPSULE. INT. CL. 9. REG. 7-12-2005.
- 2,965,424. MOXIE'S. INT. CL. 42. REG. 7-12-2005.
- 2,965,425. VALLEY VIEW. INT. CLS. 35, 36 AND 37. REG. 7-12-2005.
- 2,965,427. MISCELLANEOUS DESIGN. INT. CLS. 14, 16, 18, 24, 25, 28, 35, 38, 39, 41 AND 42. REG. 7-12-2005.
- 2,965,433. THE WIRELESS HOSPITAL. INT. CLS. 9, 10 AND 20. REG. 7-12-2005.
- 2,965,436. ASHRAM AND DESIGN. INT. CL. 25. REG. 7-12-2005.
- 2,965,437. MISCELLANEOUS DESIGN. INT. CLS. 35, 36, 41 AND 42. REG. 7-12-2005.
- 2,965,444. LUMBA PRO. INT. CL. 10. REG. 7-12-2005.
- 2,965,449. MISCELLANEOUS DESIGN. INT. CLS. 9 AND 42. REG. 7-12-2005.
- 2,965,452. TABALUGA AND DESIGN. INT. CLS. 3, 5, 8, 9, 11, 14, 15, 16, 18, 20, 21, 24, 25, 27, 28, 29, 30, 32, 35, 41 AND 42. REG. 7-12-2005.
- 2,965,469. C-TICKET. INT. CLS. 9, 16 AND 38. REG. 7-12-2005.
- 2,965,473. NSERVER. INT. CL. 9. REG. 7-12-2005.
- 2,965,482. ADR INTERNATIONAL AND DESIGN. INT. CL. 16. REG. 7-12-2005.

- 2,965,490. BODY ALIVE AND DESIGN. INT. CL. 25. REG. 7-12-2005.
- 2,965,505. SABELT AND DESIGN. INT. CLS. 9, 12, 14, 25 AND 28. REG. 7-12-2005.
- 2,965,523. MULTI-PURE. INT. CL. 5. REG. 7-12-2005.
- 2,965,550. ANRUB. INT. CL. 37. REG. 7-12-2005.
- 2,965,568. EPSAP. INT. CL. 42. REG. 7-12-2005.
- 2,965,576. STEINER PARIS AND DESIGN. INT. CLS. 20, 24 AND 27. REG. 7-12-2005.
- 2,965,600. KEYO. INT. CLS. 3, 18, 20, 24, 25 AND 35. REG. 7-12-2005.
- 2,965,603. HL HOOD LIFE APPAREL AND DESIGN. INT. CL. 25. REG. 7-12-2005.
- 2,965,605. EPRIDE. INT. CL. 5. REG. 7-12-2005.
- 2,965,610. MISCELLANEOUS DESIGN. INT. CLS. 9, 14, 28 AND 38. REG. 7-12-2005.
- 2,965,612. MITIGAIN. INT. CL. 5. REG. 7-12-2005.
- 2,965,613. TELOGRO. INT. CL. 5. REG. 7-12-2005.
- 2,965,627. MISCELLANEOUS DESIGN. INT. CLS. 5, 40, 42 AND 44. REG. 7-12-2005.
- 2,965,637. DNSE STANDARD CHARACTER MARK. INT. CL. 9. REG. 7-12-2005.
- 2,965,652. GIULIANOI AND DESIGN. INT. CL. 3. REG. 7-12-2005.
- 2,965,890. DORIOD STANDARD CHARACTER MARK. INT. CL. 5. REG. 7-12-2005.
- 2,965,894. VIDIACT STANDARD CHARACTER MARK. INT. CL. 5. REG. 7-12-2005.
- 2,966,148. SUPER TARGET MAXIMIZER. INT. CL. 35. REG. 7-12-2005.
- 2,966,149. WILL MY MONEY LAST. INT. CL. 36. REG. 7-12-2005.
- 2,966,150. BIRKOCOMFORT. INT. CL. 25. REG. 7-12-2005.
- 2,966,152. VITALITY. INT. CL. 4. REG. 7-12-2005.
- 2,966,153. TOASTY CRACKERS AND DESIGN. INT. CL. 30. REG. 7-12-2005.
- 2,966,154. TOASTY CRACKERS (STYLIZED). INT. CL. 30. REG. 7-12-2005.
- 2,966,158. MEGABRID AND DESIGN. INT. CL. 9. REG. 7-12-2005.
- 2,966,163. KEMPUS. INT. CL. 33. REG. 7-12-2005.
- 2,966,168. ROTANA AND DESIGN. INT. CLS. 29, 30, 31 AND 32. REG. 7-12-2005.
- 2,966,174. SINU (STYLIZED). INT. CL. 42. REG. 7-12-2005.
- 2,966,179. CC AND DESIGN. INT. CL. 25. REG. 7-12-2005.
- 2,966,182. LIFE ENHANCING DENTISTRY. INT. CL. 44. REG. 7-12-2005.
- 2,966,194. NUNZA. INT. CLS. 31, 35 AND 44. REG. 7-12-2005.
- 2,966,199. SOYAFE. INT. CL. 30. REG. 7-12-2005.
- 2,966,201. MEDICAL TUESDAY. INT. CLS. 36 AND 38 ONLY. REG. 7-12-2005.
- 2,966,210. AGNES B. SPORT AND DESIGN. INT. CLS. 3, 14, 18, 24 AND 25. REG. 7-12-2005.
- 2,966,230. CPA2CLIENT (STYLIZED). INT. CLS. 36, 41 AND 42. REG. 7-12-2005.
- 2,966,268. H HOTEL COLLECTION BY CHARTER CLUB AND DESIGN. INT. CLS. 21, 24 AND 27. REG. 7-12-2005.
- 2,966,272. MISCELLANEOUS DESIGN. INT. CL. 9. REG. 7-12-2005.
- 2,966,399. ACTAMESA. INT. CL. 42. REG. 7-12-2005.
- 2,966,468. E-STATION. INT. CL. 10. REG. 7-12-2005.
- 2,967,307. OPTIMUM Q - MARKET NEUTRAL EQUITIZED STANDARD CHARACTER MARK. INT. CL. 36. REG. 7-12-2005.
- 2,967,308. PEOPLESUB. INT. CL. 42. REG. 7-12-2005.
- 2,967,309. E2 (STYLIZED). INT. CL. 25. REG. 7-12-2005.
- 2,967,316. SCHWAB SIGNATURE. INT. CL. 36. REG. 7-12-2005.
- 2,967,317. VETRURIA. INT. CLS. 21 AND 35. REG. 7-12-2005.
- 2,967,319. INSTRANET. INT. CL. 9. REG. 7-12-2005.
- 2,967,320. HOME PHONELINE NETWORK CERTIFIED AND DESIGN. INT. CL. 42. REG. 7-12-2005.
- 2,967,322. PRESIDENTIAL AIR CHARTERS. INT. CL. 39. REG. 7-12-2005.
- 2,967,323. NO ROADRAGE. INT. CL. 16. REG. 7-12-2005.
- 2,967,324. SEXTREME. INT. CL. 5. REG. 7-12-2005.
- 2,967,325. FRIAR & FIRKIN A FIRKIN FREEHOUSE AND DESIGN. INT. CL. 42. REG. 7-12-2005.
- 2,967,327. OM SOLAR. INT. CLS. 16, 19, 41 AND 42. REG. 7-12-2005.
- 2,967,328. THE METAL GODS. INT. CL. 41. REG. 7-12-2005.
- 2,967,329. FACTORYXML. INT. CL. 9. REG. 7-12-2005.
- 2,967,330. INVERO. INT. CL. 12. REG. 7-12-2005.
- 2,967,331. EQUIRE (STYLIZED). INT. CLS. 35, 39 AND 42. REG. 7-12-2005.
- 2,967,333. TISSUES TO GO. INT. CL. 21. REG. 7-12-2005.
- 2,967,335. THORODIN. INT. CL. 1. REG. 7-12-2005.
- 2,967,337. FAST & LIGHT. INT. CLS. 11 AND 21. REG. 7-12-2005.
- 2,967,338. UNIFRAME. INT. CL. 6. REG. 7-12-2005.
- 2,967,339. ISEEMEDIA. INT. CL. 9. REG. 7-12-2005.
- 2,967,340. TELCOTRADE. INT. CL. 36. REG. 7-12-2005.
- 2,967,341. ROWENTA POWERPRESS. INT. CL. 9. REG. 7-12-2005.
- 2,967,346. FREIGHT DEPOT. INT. CL. 39. REG. 7-12-2005.
- 2,967,347. MASTERS OF THE UNIVERSE. INT. CLS. 3, 9, 16, 20, 21, 24, 25, 26, 28 AND 41. REG. 7-12-2005.
- 2,967,350. YOUR PLANET EARTH. INT. CLS. 38 AND 42. REG. 7-12-2005.
- 2,967,353. OPTIMOS. INT. CL. 9. REG. 7-12-2005.
- 2,967,355. INTARSIA. INT. CLS. 9 AND 42. REG. 7-12-2005.
- 2,967,360. ADVANCED RESOLUTION AND DESIGN. INT. CL. 9. REG. 7-12-2005.
- 2,967,362. CORPORATE CONNECTIONS. INT. CL. 35. REG. 7-12-2005.
- 2,967,368. FRX WEBPORT. INT. CL. 9. REG. 7-12-2005.
- 2,967,370. ACTION. INT. CL. 24. REG. 7-12-2005.
- 2,967,373. VIRAPLEX. INT. CL. 5. REG. 7-12-2005.
- 2,967,374. DATAMARKETS. INT. CLS. 38 AND 42. REG. 7-12-2005.
- 2,967,378. DOCTORAT.COM. INT. CL. 35. REG. 7-12-2005.
- 2,967,379. XTREMESPECTRUM. INT. CL. 9. REG. 7-12-2005.
- 2,967,386. SOCRATES. INT. CL. 9. REG. 7-12-2005.
- 2,967,387. VISTO. INT. CL. 38. REG. 7-12-2005.
- 2,967,388. M AND DESIGN. INT. CL. 16. REG. 7-12-2005.
- 2,967,390. SOUTHERN COMPANY ENERGY. INT. CL. 39. REG. 7-12-2005.
- 2,967,391. PAINT LIFE. INT. CL. 2. REG. 7-12-2005.
- 2,967,393. MISCELLANEOUS DESIGN. INT. CL. 5. REG. 7-12-2005.
- 2,967,394. GALA. INT. CL. 16. REG. 7-12-2005.
- 2,967,402. WHO'S FAST. INT. CL. 42. REG. 7-12-2005.
- 2,967,406. DEFINE. INT. CL. 5. REG. 7-12-2005.
- 2,967,407. JUST 4 FAMILY AND FRIENDS. INT. CL. 42. REG. 7-12-2005.
- 2,967,408. XTREME ZONE. INT. CLS. 10, 14 AND 28. REG. 7-12-2005.
- 2,967,410. GENESIS CONSULTING SERVICES AND DESIGN. INT. CLS. 35 AND 42. REG. 7-12-2005.
- 2,967,411. FAME FASHION AVENUE MARKET EXPO. INT. CL. 35. REG. 7-12-2005.
- 2,967,412. BILL BONE. INT. CL. 3. REG. 7-12-2005.
- 2,967,413. THE GHOSTLY TRIO. INT. CL. 28. REG. 7-12-2005.
- 2,967,415. NANOBREATH. INT. CLS. 9 AND 10. REG. 7-12-2005.
- 2,967,416. G (STYLIZED). INT. CL. 25. REG. 7-12-2005.
- 2,967,418. MISCELLANEOUS DESIGN. INT. CLS. 1, 5, 9 AND 10. REG. 7-12-2005.
- 2,967,419. PURE MATRIX. INT. CL. 42. REG. 7-12-2005.
- 2,967,420. COM TEC AND DESIGN. INT. CLS. 1 AND 3. REG. 7-12-2005.
- 2,967,422. VIRTUAL DIGI TIRE. INT. CL. 9. REG. 7-12-2005.
- 2,967,423. IWORKINSTRUCTION. INT. CL. 9. REG. 7-12-2005.
- 2,967,426. 980. INT. CL. 7. REG. 7-12-2005.
- 2,967,429. TEST YOUR METTLE. INT. CL. 32. REG. 7-12-2005.
- 2,967,432. IMPACT EXPERIENCE. INT. CL. 41. REG. 7-12-2005.
- 2,967,434. SYMMETRICS AND DESIGN. INT. CL. 35. REG. 7-12-2005.
- 2,967,435. BODYBAR. INT. CL. 5. REG. 7-12-2005.
- 2,967,436. NALGENE GOCUP. INT. CL. 21. REG. 7-12-2005.

- 2,967,439. PHOSPHO-LAX. INT. CL. 5. REG. 7-12-2005.
 2,967,440. SYNDICATED PROFESSOR. INT. CL. 41. REG. 7-12-2005.
 2,967,441. NEOLIPID. INT. CL. 5. REG. 7-12-2005.
 2,967,442. RAISING MORE MONEY BUILDING LIFELONG DONORS AND DESIGN. INT. CLS. 16 AND 41. REG. 7-12-2005.
 2,967,447. EL PASO GRILL & BAR-B-QUE. INT. CL. 42. REG. 7-12-2005.
 2,967,448. THE NEW GLOBE. INT. CL. 41. REG. 7-12-2005.
 2,967,451. MIS MINIMALLY INVASIVE - - - - SOLUTIONS AND DESIGN. INT. CL. 35. REG. 7-12-2005.
 2,967,455. MEDICINE POUCH. INT. CL. 31. REG. 7-12-2005.
 2,967,459. LICKERISH. INT. CL. 28. REG. 7-12-2005.
 2,967,461. PET TEENAGER. INT. CL. 28. REG. 7-12-2005.
 2,967,464. QUILL MEDICAL (STYLIZED). INT. CL. 10. REG. 7-12-2005.
 2,967,466. LOOPHOLES OF THE RICH. INT. CL. 16. REG. 7-12-2005.
 2,967,468. MYBEAUTY. INT. CL. 3. REG. 7-12-2005.
 2,967,471. NBDL FAYETTEVILLE PATRIOTS AND DESIGN. INT. CL. 16. REG. 7-12-2005.
 2,967,472. NBDL COLUMBUS RIVERDRAGONS AND DESIGN. INT. CL. 18. REG. 7-12-2005.
 2,967,473. BIOBLEND. INT. CL. 10. REG. 7-12-2005.
 2,967,477. MI AND DESIGN. INT. CL. 9. REG. 7-12-2005.
 2,967,478. MAX PAYNE. INT. CL. 28. REG. 7-12-2005.
 2,967,479. SEE THE WORLD IN A NEW LIGHT. INT. CLS. 35, 37 AND 42. REG. 7-12-2005.
 2,967,481. BLUE NICKEL. INT. CL. 15. REG. 7-12-2005.
 2,967,482. FLORATTA IN GOLD O Boticário AND DESIGN. INT. CL. 3. REG. 7-12-2005.
 2,967,484. POWERING WHAT'S NEXT. INT. CL. 9. REG. 7-12-2005.
 2,967,489. CORPORATE KINGDOM. INT. CLS. 16 AND 21. REG. 7-12-2005.
 2,967,491. V FLORIDA7 AND DESIGN. INT. CL. 32. REG. 7-12-2005.
 2,967,498. IMAGE X MEDIA. INT. CLS. 9 AND 41. REG. 7-12-2005.
 2,967,499. POLYSTRIDE. INT. CL. 25. REG. 7-12-2005.
 2,967,504. SWITCH TO PERFECTION RITTAL AND DESIGN. INT. CLS. 9, 11 AND 42. REG. 7-12-2005.
 2,967,506. LUMIERES D'ARTIFICES (STYLIZED). INT. CL. 3. REG. 7-12-2005.
 2,967,507. GIRL MANIA. INT. CLS. 20 AND 24. REG. 7-12-2005.
 2,967,509. TURB-O-WEB. INT. CL. 42. REG. 7-12-2005.
 2,967,510. PM PIERRE MENDY PARIS AND DESIGN. INT. CLS. 18 AND 25. REG. 7-12-2005.
 2,967,512. KOATI. INT. CL. 9. REG. 7-12-2005.
 2,967,515. SLIC. INT. CL. 9. REG. 7-12-2005.
 2,967,516. EXPAND BEYOND. INT. CL. 9. REG. 7-12-2005.
 2,967,517. SURESTOP. INT. CLS. 37 AND 42. REG. 7-12-2005.
 2,967,518. LA JINN THE MYSTICAL GENIE OF THE LAMP. INT. CL. 28. REG. 7-12-2005.
 2,967,519. EAGLE. INT. CL. 28. REG. 7-12-2005.
 2,967,520. ARCOR CEREAL MIX AND DESIGN. INT. CL. 30. REG. 7-12-2005.
 2,967,522. AIR BRONZER. INT. CL. 3. REG. 7-12-2005.
 2,967,523. CDR-PATIENT (STYLIZED). INT. CL. 9. REG. 7-12-2005.
 2,967,524. NRAM. INT. CL. 9. REG. 7-12-2005.
 2,967,528. FAMILIES OF SEPTEMBER 11. INT. CL. 42. REG. 7-12-2005.
 2,967,529. NO FORKS REQUIRED. INT. CLS. 29 AND 30. REG. 7-12-2005.
 2,967,533. SOPHERION THERAPEUTICS. INT. CL. 42. REG. 7-12-2005.
 2,967,534. SWEEP SENSOR. INT. CL. 9. REG. 7-12-2005.
 2,967,539. AMERICAN IS MY NAME FREEDOM IS MY GAME. INT. CL. 25. REG. 7-12-2005.
 2,967,540. AFG. INT. CL. 36. REG. 7-12-2005.
 2,967,542. M&M'S (STYLIZED). INT. CL. 28. REG. 7-12-2005.
 2,967,543. M&M'S. INT. CL. 28. REG. 7-12-2005.
 2,967,544. FREEDOM PACKAGE. INT. CL. 38. REG. 7-12-2005.
 2,967,545. THE SCIENCE OF BEING WELL. INT. CL. 5. REG. 7-12-2005.
 2,967,547. MIKE'S HARD CRANBERRY LEMONADE. INT. CLS. 18 AND 25. REG. 7-12-2005.
 2,967,549. TOPPCURE. INT. CL. 17. REG. 7-12-2005.
 2,967,556. HITCH-A-CINCH. INT. CL. 9. REG. 7-12-2005.
 2,967,557. AMRITA. INT. CLS. 3, 25, 41, 43 AND 44. REG. 7-12-2005.
 2,967,558. SAFETYSQUARE AND DESIGN. INT. CL. 9. REG. 7-12-2005.
 2,967,563. SYNEXUS GLOBAL. INT. CL. 9. REG. 7-12-2005.
 2,967,564. SANTEE MADE IN U.S.A. AND DESIGN. INT. CLS. 7 AND 12. REG. 7-12-2005.
 2,967,566. SOFTLINK LIBERTY. INT. CL. 9. REG. 7-12-2005.
 2,967,567. PROLIANT. INT. CL. 7. REG. 7-12-2005.
 2,967,568. SOMETHING GOOD INC. AND DESIGN. INT. CL. 41. REG. 7-12-2005.
 2,967,571. 'SCOOL. INT. CL. 41. REG. 7-12-2005.
 2,967,573. COUNTERTOP ON DEMAND. INT. CL. 19. REG. 7-12-2005.
 2,967,575. HYDRICITY. INT. CL. 9. REG. 7-12-2005.
 2,967,577. NAMECHARMERS. INT. CL. 21. REG. 7-12-2005.
 2,967,579. HAWAIIANBUILT. INT. CLS. 9, 18 AND 28. REG. 7-12-2005.
 2,967,580. MOVIN' OUT AND DESIGN. INT. CL. 25. REG. 7-12-2005.
 2,967,583. GONE SCRAPPIN'. INT. CL. 16. REG. 7-12-2005.
 2,967,584. OAK CREEK HOME. INT. CL. 27. REG. 7-12-2005.
 2,967,585. MICRO BLAST R/C RACERS. INT. CL. 28. REG. 7-12-2005.
 2,967,586. PHYSO AMINO. INT. CL. 3. REG. 7-12-2005.
 2,967,587. BOOT HILL EXPRESS. INT. CL. 28. REG. 7-12-2005.
 2,967,595. TIP PIK PRO TOOL AND DESIGN. INT. CL. 28. REG. 7-12-2005.
 2,967,596. MOOSE RIVER. INT. CL. 43. REG. 7-12-2005.
 2,967,597. SOLUTIONS FOR SAFETY. INT. CL. 10. REG. 7-12-2005.
 2,967,598. SPEEDIUM. INT. CL. 12. REG. 7-12-2005.
 2,967,599. BITWISE COMMUNICATIONS. INT. CL. 38. REG. 7-12-2005.
 2,967,604. KINESIS AND DESIGN. INT. CL. 25. REG. 7-12-2005.
 2,967,606. NEC ELECTRONICS. INT. CL. 9. REG. 7-12-2005.
 2,967,607. CLICK TO DVD. INT. CL. 9. REG. 7-12-2005.
 2,967,608. MONTEREY. INT. CL. 20. REG. 7-12-2005.
 2,967,612. AMI. INT. CL. 45. REG. 7-12-2005.
 2,967,614. TROLLEY'S. INT. CL. 43. REG. 7-12-2005.
 2,967,617. WHAT'S YOUR CUSTOMER FACING. INT. CLS. 35, 40 AND 42. REG. 7-12-2005.
 2,967,618. COTTAGES OF STONEHENGE. INT. CL. 36. REG. 7-12-2005.
 2,967,622. SEEWITHIN/PRO AND DESIGN. INT. CL. 9. REG. 7-12-2005.
 2,967,625. URBANASOFTWARE AND DESIGN. INT. CL. 9. REG. 7-12-2005.
 2,967,628. HENRI VALLET LA PALOMA (STYLIZED). INT. CL. 33. REG. 7-12-2005.
 2,967,631. WE'LL GREET YOU BY NAME. INT. CL. 35. REG. 7-12-2005.
 2,967,632. BARBARA K AND DESIGN. INT. CL. 25. REG. 7-12-2005.
 2,967,633. GRINS. INT. CLS. 35 AND 36. REG. 7-12-2005.
 2,967,634. PENSIONSHARES. INT. CLS. 35 AND 36. REG. 7-12-2005.
 2,967,635. PRETTY PETALS. INT. CL. 16. REG. 7-12-2005.
 2,967,636. STOREBOARD. INT. CL. 35. REG. 7-12-2005.
 2,967,637. I ZONE. INT. CL. 41. REG. 7-12-2005.
 2,967,639. FIRST AID ALERT. INT. CL. 6. REG. 7-12-2005.
 2,967,640. BAREFOOT BOTANICALS AND DESIGN. INT. CLS. 3 AND 5. REG. 7-12-2005.
 2,967,642. GROOMING FROM THE INSIDE. INT. CL. 5. REG. 7-12-2005.
 2,967,644. RAMA RIBBIT .COM AND DESIGN. INT. CL. 35. REG. 7-12-2005.
 2,967,645. THE WATCHDOG COLLECTION AND DESIGN. INT. CL. 9. REG. 7-12-2005.

- 2,967,648. META-ACCELERATOR. INT. CL. 5. REG. 7-12-2005.
- 2,967,651. TEN MAX AND DESIGN. INT. CL. 38. REG. 7-12-2005.
- 2,967,652. TEN CLIPS AND DESIGN. INT. CL. 38. REG. 7-12-2005.
- 2,967,653. TEN BLUE AND DESIGN. INT. CL. 38. REG. 7-12-2005.
- 2,967,656. WRITE TO READ. INT. CL. 16. REG. 7-12-2005.
- 2,967,657. MISCELLANEOUS DESIGN. INT. CL. 5. REG. 7-12-2005.
- 2,967,659. KLER. INT. CL. 20. REG. 7-12-2005.
- 2,967,661. TITAN SHAPES SYSTEM. INT. CL. 9. REG. 7-12-2005.
- 2,967,662. TEMPLE KEEPERS BY GUIDING LITE AND DESIGN. INT. CL. 41. REG. 7-12-2005.
- 2,967,664. GLOSS JUNKIE. INT. CL. 3. REG. 7-12-2005.
- 2,967,670. SKATE CONCEPT. INT. CL. 28. REG. 7-12-2005.
- 2,967,671. BRANDSCAPE. INT. CL. 42. REG. 7-12-2005.
- 2,967,675. REAL RELATIONSHIPS. REAL RESULTS.. INT. CLS. 38, 41 AND 44. REG. 7-12-2005.
- 2,967,676. GRIPTITE. INT. CL. 9. REG. 7-12-2005.
- 2,967,678. UNIVERSAL AND DESIGN. INT. CL. 11. REG. 7-12-2005.
- 2,967,680. RED CHARGE. INT. CL. 32. REG. 7-12-2005.
- 2,967,684. SNUGLETS. INT. CL. 14. REG. 7-12-2005.
- 2,967,685. MISCELLANEOUS DESIGN. INT. CL. 39. REG. 7-12-2005.
- 2,967,686. 3 IN 3. INT. CL. 3. REG. 7-12-2005.
- 2,967,691. FUNKMASTER FLEX. INT. CL. 9. REG. 7-12-2005.
- 2,967,692. FUNKMASTER FLEX. INT. CL. 28. REG. 7-12-2005.
- 2,967,693. STA-DOCK. INT. CL. 6. REG. 7-12-2005.
- 2,967,694. MEYER COUNTRY FARMS. INT. CL. 40. REG. 7-12-2005.
- 2,967,700. IN2. INT. CL. 7. REG. 7-12-2005.
- 2,967,701. GRAVITYGRIPPER (STYLIZED). INT. CL. 28. REG. 7-12-2005.
- 2,967,702. WRAP A BYE BABY. INT. CL. 24. REG. 7-12-2005.
- 2,967,703. SALVADOR SAPENA. INT. CL. 25. REG. 7-12-2005.
- 2,967,705. THIS TAKES THE CAKE. INT. CL. 16. REG. 7-12-2005.
- 2,967,707. JUNCTION PRODUCE HIGH SOCIETY SALOON GALLERY JP AND DESIGN. INT. CL. 12. REG. 7-12-2005.
- 2,967,709. CMSI. INT. CLS. 9 AND 42. REG. 7-12-2005.
- 2,967,711. CREATION GUITARS. INT. CL. 15. REG. 7-12-2005.
- 2,967,713. STORAGEFLEX. INT. CLS. 9 AND 42. REG. 7-12-2005.
- 2,967,714. RAPIDO. INT. CL. 3. REG. 7-12-2005.
- 2,967,717. ORBY LIGHT-UP PRODUCTS NIGHT- LIGHT-FLIGHT AND DESIGN. INT. CL. 28. REG. 7-12-2005.
- 2,967,721. RAINGLEN. INT. CL. 9. REG. 7-12-2005.
- 2,967,722. MARSHMALLOW MINT. INT. CL. 31. REG. 7-12-2005.
- 2,967,723. ACCESS BY KATUN. INT. CLS. 2 AND 9. REG. 7-12-2005.
- 2,967,725. BOOMERANG. INT. CL. 28. REG. 7-12-2005.
- 2,967,728. DNA WITH PAP. INT. CL. 5. REG. 7-12-2005.
- 2,967,729. MISCELLANEOUS DESIGN. INT. CL. 32. REG. 7-12-2005.
- 2,967,730. CASIMIR WEAR. INT. CL. 25. REG. 7-12-2005.
- 2,967,731. AMPLIFY FPGA. INT. CL. 9. REG. 7-12-2005.
- 2,967,732. FAMOUS SURF WAX AND DESIGN. INT. CL. 21. REG. 7-12-2005.
- 2,967,735. ESSENCE BY SWEDISH BEAUTY. INT. CL. 3. REG. 7-12-2005.
- 2,967,736. PERFECTLY REWARDING. INT. CL. 36. REG. 7-12-2005.
- 2,967,737. BILLY HATCHER AND THE GIANT EGG. INT. CL. 9. REG. 7-12-2005.
- 2,967,744. AIREDEP. INT. CL. 35. REG. 7-12-2005.
- 2,967,746. C&N (STYLIZED). INT. CL. 29. REG. 7-12-2005.
- 2,967,748. THE FRUGIES. INT. CL. 41. REG. 7-12-2005.
- 2,967,749. METALLUSIONS. INT. CLS. 11 AND 21. REG. 7-12-2005.
- 2,967,753. FATS HOSTILE FIRE SIMULATOR. INT. CL. 9. REG. 7-12-2005.
- 2,967,755. BASIC SOLUTIONS. INT. CL. 5. REG. 7-12-2005.
- 2,967,759. [KXSYSTEMS] AND DESIGN. INT. CL. 9. REG. 7-12-2005.
- 2,967,764. AG-MAXX. INT. CL. 7. REG. 7-12-2005.
- 2,967,765. JESSICA S. INT. CLS. 26 AND 28. REG. 7-12-2005.
- 2,967,766. SCRAPBOOKING REDEFINED. INT. CL. 16. REG. 7-12-2005.
- 2,967,773. PAPAYA KING AND DESIGN. INT. CL. 29. REG. 7-12-2005.
- 2,967,774. ATKINS AM CLEANSE. INT. CL. 5. REG. 7-12-2005.
- 2,967,776. RADIOVISA. INT. CL. 38. REG. 7-12-2005.
- 2,967,777. DIRECTLINE. INT. CL. 9. REG. 7-12-2005.
- 2,967,781. THREESIXTEEN. INT. CL. 41. REG. 7-12-2005.
- 2,967,785. WE SHOW YOU HOW. INT. CL. 35. REG. 7-12-2005.
- 2,967,786. WE'LL SHOW YOU HOW. INT. CL. 35. REG. 7-12-2005.
- 2,967,787. TAKING CARE. INT. CLS. 35 AND 36. REG. 7-12-2005.
- 2,967,789. USVI360.COM. INT. CL. 35. REG. 7-12-2005.
- 2,967,791. RED THUNDER. INT. CL. 25. REG. 7-12-2005.
- 2,967,795. MEDCLOSE. INT. CL. 10. REG. 7-12-2005.
- 2,967,796. SAFETY DISPATCH TEAM. INT. CL. 45. REG. 7-12-2005.
- 2,967,797. VIDEO POKER PARLOUR AND DESIGN. INT. CL. 41. REG. 7-12-2005.
- 2,967,800. CONNECTEDTHINKING. INT. CL. 36. REG. 7-12-2005.
- 2,967,801. NLEC. INT. CL. 38. REG. 7-12-2005.
- 2,967,802. DARE TO LEAD!. INT. CL. 28. REG. 7-12-2005.
- 2,967,803. INSTALLSHIELD DEVSTUDIO. INT. CL. 9. REG. 7-12-2005.
- 2,967,804. OPTICALSYSTEMS AND DESIGN. INT. CL. 9. REG. 7-12-2005.
- 2,967,805. BRILLIANT BLUE. INT. CL. 5. REG. 7-12-2005.
- 2,967,806. GRAB THE CARD AND GET IT DONE. INT. CL. 35. REG. 7-12-2005.
- 2,967,810. DZYNSPEC. INT. CLS. 19 AND 27. REG. 7-12-2005.
- 2,967,817. ARTLASC (STYLIZED). INT. CL. 9. REG. 7-12-2005.
- 2,967,818. THUMBY. INT. CL. 28. REG. 7-12-2005.
- 2,967,825. PEACE, LOVE & GRILLED CHEESES. INT. CL. 25. REG. 7-12-2005.
- 2,967,827. DKM. INT. CL. 25. REG. 7-12-2005.
- 2,967,832. COMPUCARDS. INT. CL. 16. REG. 7-12-2005.
- 2,967,835. MAGIC-COAT. INT. CL. 21. REG. 7-12-2005.
- 2,967,836. SERVICE TAKEN SERIOUSLY. INT. CL. 36. REG. 7-12-2005.
- 2,967,839. PROTECH MOTORCYCLES. INT. CL. 35. REG. 7-12-2005.
- 2,967,841. FATIGUE PROJECT AND DESIGN. INT. CL. 25. REG. 7-12-2005.
- 2,967,842. BUILD YOUR MIND, BUILD YOUR SOUL, BUILD YOURSELF. INT. CL. 20. REG. 7-12-2005.
- 2,967,844. VISION BEYOND SOUND. INT. CL. 9. REG. 7-12-2005.
- 2,967,846. INGLES WISDOM CONVERSACAO. INT. CL. 41. REG. 7-12-2005.
- 2,967,848. SLEEMAN SILVER CREEK LAGER AND DESIGN. INT. CL. 32. REG. 7-12-2005.
- 2,967,849. ALL WATER IS NOT CREATED EQUAL. INT. CL. 32. REG. 7-12-2005.
- 2,967,850. BIRTHVERSE AND DESIGN. INT. CLS. 16 AND 20. REG. 7-12-2005.
- 2,967,851. CLAY SOUP. INT. CLS. 16 AND 25. REG. 7-12-2005.
- 2,967,858. DOSE-A-DAY. INT. CL. 9. REG. 7-12-2005.
- 2,967,859. THERMO-CONTROL. INT. CL. 3. REG. 7-12-2005.
- 2,967,862. B AND DESIGN. INT. CL. 21. REG. 7-12-2005.
- 2,967,863. NIGHT STAND. INT. CL. 35. REG. 7-12-2005.
- 2,967,868. REDCANNON AND DESIGN. INT. CL. 9. REG. 7-12-2005.

- 2,967,869. FOOT EFX. INT. CL. 10. REG. 7-12-2005.
 2,967,870. HANS' WRAP (STYLIZED). INT. CL. 30. REG. 7-12-2005.
 2,967,873. FRESH YOGA. INT. CL. 41. REG. 7-12-2005.
 2,967,874. TEAMLINKEXP. INT. CL. 9. REG. 7-12-2005.
 2,967,879. K. SCHORLE PANOMAN. INT. CLS. 16 AND 41. REG. 7-12-2005.
 2,967,881. MACRESO. INT. CL. 40. REG. 7-12-2005.
 2,967,883. MEMBERSHIP CIRCLE. INT. CL. 38. REG. 7-12-2005.
 2,967,885. NUTRICORE AND DESIGN. INT. CL. 42. REG. 7-12-2005.
 2,967,892. LAS VEGAS MILLION DOLLAR SHOOTOUT AND DESIGN. INT. CL. 41. REG. 7-12-2005.
 2,967,895. NEBULAIR. INT. CL. 10. REG. 7-12-2005.
 2,967,896. BIRDIE. INT. CL. 18. REG. 7-12-2005.
 2,967,897. NEW CAR SHINE, EVERY TIME STANDARD CHARACTER MARK. INT. CL. 3. REG. 7-12-2005.
 2,967,898. SPEAK EASY. INT. CL. 20. REG. 7-12-2005.
 2,967,899. V-MASS MARAGE. INT. CL. 28. REG. 7-12-2005.
 2,967,902. THE ODD MAN OUT (STYLIZED). INT. CL. 16. REG. 7-12-2005.
 2,967,905. MODERN MADE TO MEASURE. INT. CL. 25. REG. 7-12-2005.
 2,967,907. MOONDAWG. INT. CL. 21. REG. 7-12-2005.
 2,967,914. VACATION SUN AND DESIGN. INT. CL. 3. REG. 7-12-2005.
 2,967,915. HOMETOWN PEST CONTROL. INT. CL. 37. REG. 7-12-2005.
 2,967,916. P.K. MAK'S SLIMFITTEES. INT. CL. 25. REG. 7-12-2005.
 2,967,917. TOTAL SCENTS. INT. CL. 3. REG. 7-12-2005.
 2,967,919. JENNALEE. INT. CL. 18. REG. 7-12-2005.
 2,967,921. WHIRL-O. INT. CL. 28. REG. 7-12-2005.
 2,967,922. SHELLACK. INT. CL. 41. REG. 7-12-2005.
 2,967,924. BRISTOL WEST ONESTEP. INT. CLS. 36 AND 42. REG. 7-12-2005.
 2,967,926. MAKING AMERICA BEAUTIFUL. INT. CL. 2. REG. 7-12-2005.
 2,967,928. LOVE-IT-STRAIGHT. INT. CL. 3. REG. 7-12-2005.
 2,967,938. TREASURE COVE AND DESIGN. INT. CL. 22. REG. 7-12-2005.
 2,967,939. TREASURE COVE (STYLIZED). INT. CL. 22. REG. 7-12-2005.
 2,967,942. TRADE FOR HOPE. INT. CL. 36. REG. 7-12-2005.
 2,967,943. ZUNAFISH AND DESIGN. INT. CL. 35. REG. 7-12-2005.
 2,967,947. XTREME EPV (STYLIZED). INT. CL. 9. REG. 7-12-2005.
 2,967,948. MISCELLANEOUS DESIGN. INT. CL. 25. REG. 7-12-2005.
 2,967,953. SCOTSMAN CAPITAL MANAGEMENT STANDARD CHARACTER MARK. INT. CL. 36. REG. 7-12-2005.
 2,967,956. TWISTY PLEASE STANDARD CHARACTER MARK. INT. CL. 31. REG. 7-12-2005.
 2,967,957. NSAC (STYLIZED). INT. CL. 41. REG. 7-12-2005.
 2,967,960. ZOOM-BROOM STANDARD CHARACTER MARK. INT. CL. 21. REG. 7-12-2005.
 2,967,978. WHERE GREAT SHOPPING LIVES STANDARD CHARACTER MARK. INT. CL. 36. REG. 7-12-2005.
 2,967,980. HERO. INT. CL. 42. REG. 7-12-2005.
 2,967,981. CLEAR CHANNEL WORLDWIDE. INT. CLS. 25 AND 35. REG. 7-12-2005.
 2,967,982. SNAP. INT. CL. 10. REG. 7-12-2005.
 2,967,987. V VOTORANTIM AND DESIGN. INT. CL. 19. REG. 7-12-2005.
 2,967,988. RAVINIA ACCENTS. INT. CL. 26. REG. 7-12-2005.
 2,967,989. EN AND DESIGN. INT. CL. 25. REG. 7-12-2005.
 2,967,993. ONE TO ONE TV. INT. CL. 42. REG. 7-12-2005.
 2,967,995. TIGEX. INT. CL. 21. REG. 7-12-2005.
 2,967,997. PRODERMA. INT. CL. 3. REG. 7-12-2005.
 2,967,999. B4STUDENTS. INT. CL. 41. REG. 7-12-2005.
 2,968,000. BOLTBLUE. INT. CL. 38. REG. 7-12-2005.
 2,968,001. GOCANCUN. INT. CLS. 16, 39 AND 41. REG. 7-12-2005.
 2,968,003. ENVIRO NEXUS. INT. CL. 35. REG. 7-12-2005.
 2,968,005. DIALTONE 2.0. INT. CLS. 35, 38 AND 42. REG. 7-12-2005.
 2,968,006. POWERNETIX. INT. CL. 9. REG. 7-12-2005.
 2,968,010. SLOPECYCLE. INT. CL. 25. REG. 7-12-2005.
 2,968,011. AT&T LABORATORIES. INT. CL. 42. REG. 7-12-2005.
 2,968,012. AT&T SHANNON LABS. INT. CL. 42. REG. 7-12-2005.
 2,968,015. WISPEE. INT. CL. 25. REG. 7-12-2005.
 2,968,017. MAGIC MUNCH. INT. CL. 30. REG. 7-12-2005.
 2,968,018. PARA TODOS AND DESIGN. INT. CL. 16. REG. 7-12-2005.
 2,968,022. PROMIRUS. INT. CL. 16. REG. 7-12-2005.
 2,968,023. DALLA PIAZZA AND DESIGN. INT. CLS. 8, 18, 21, 24, 25 AND 42. REG. 7-12-2005.
 2,968,026. WEB I AND DESIGN. INT. CL. 9. REG. 7-12-2005.
 2,968,027. SYNERCHEM. INT. CL. 1. REG. 7-12-2005.
 2,968,028. SOYUMMY. INT. CL. 29. REG. 7-12-2005.
 2,968,030. BEST COR VALU CRES COR AND DESIGN. INT. CL. 11. REG. 7-12-2005.
 2,968,031. BEST COR VALU. INT. CL. 11. REG. 7-12-2005.
 2,968,032. JUST DIP, PLACE & BAKE!. INT. CL. 30. REG. 7-12-2005.
 2,968,036. PADPOINT. INT. CL. 9. REG. 7-12-2005.
 2,968,037. PORTLAND BLAZERS AND DESIGN. INT. CL. 18. REG. 7-12-2005.
 2,968,038. THE N AND DESIGN. INT. CL. 41. REG. 7-12-2005.
 2,968,040. MAXIMUM AIR. INT. CLS. 36 AND 39. REG. 7-12-2005.
 2,968,042. TIMBERFORGE. INT. CL. 8. REG. 7-12-2005.
 2,968,043. ILPF. INT. CLS. 35 AND 41. REG. 7-12-2005.
 2,968,044. MIMI & MAGGIE. INT. CL. 25. REG. 7-12-2005.
 2,968,046. VACCRIX. INT. CL. 35. REG. 7-12-2005.
 2,968,048. TOILET TREES. INT. CL. 26. REG. 7-12-2005.
 2,968,049. LIZ CLAIBORNE. INT. CLS. 19 AND 27. REG. 7-12-2005.
 2,968,050. ILLUMITHERAPY. INT. CL. 9. REG. 7-12-2005.
 2,968,052. SUPERMOM'S. INT. CL. 35. REG. 7-12-2005.
 2,968,053. REAL GREAT CHEESE ALL WRAPPED UP. INT. CL. 29. REG. 7-12-2005.
 2,968,055. XIP-LIGHT. INT. CL. 9. REG. 7-12-2005.
 2,968,058. PRAXIS. INT. CL. 7. REG. 7-12-2005.
 2,968,059. RELAY. INT. CLS. 35, 38, 41, 44 AND 45. REG. 7-12-2005.
 2,968,062. THRILLSTER. INT. CL. 25. REG. 7-12-2005.
 2,968,064. GEEZERJOCK. INT. CL. 16. REG. 7-12-2005.
 2,968,065. LEADS LEAD EVALUATION AND DELIVERY SYSTEM. INT. CL. 35. REG. 7-12-2005.
 2,968,068. CROWN LINE OF QUALITY ADJUVANTS. INT. CL. 1. REG. 7-12-2005.
 2,968,069. LIL' JOEYS AND DESIGN. INT. CL. 33. REG. 7-12-2005.
 2,968,070. MOVE & SHRINK. INT. CL. 9. REG. 7-12-2005.
 2,968,071. CINEMARKETING. INT. CL. 35. REG. 7-12-2005.
 2,968,072. ADV-TECH. INT. CL. 19. REG. 7-12-2005.
 2,968,074. D S I AND DESIGN. INT. CL. 9. REG. 7-12-2005.
 2,968,075. PARADIX. INT. CLS. 7 AND 10. REG. 7-12-2005.
 2,968,081. STEEL-GARD. INT. CL. 16. REG. 7-12-2005.
 2,968,082. WHISTLE CREEK. INT. CL. 33. REG. 7-12-2005.
 2,968,083. CT56. INT. CL. 9. REG. 7-12-2005.
 2,968,085. CRISTAL. INT. CL. 12. REG. 7-12-2005.
 2,968,086. TRIO. INT. CL. 16. REG. 7-12-2005.
 2,968,087. EXTREME WEATHER FROM SUN-TEK SKY-LIGHTS AND DESIGN. INT. CL. 6. REG. 7-12-2005.
 2,968,089. PEPPERCOIN. INT. CL. 9. REG. 7-12-2005.
 2,968,091. GOOD HEALTH IS TRUE WEALTH. INT. CL. 41. REG. 7-12-2005.
 2,968,094. APTSOFT. INT. CL. 9. REG. 7-12-2005.
 2,968,095. CSG CLEANING SOLUTIONS GROUP AND DESIGN. INT. CL. 5. REG. 7-12-2005.
 2,968,096. FABRICTOUCH. INT. CL. 16. REG. 7-12-2005.
 2,968,097. MODULAR STEPS AND DESIGN. INT. CL. 28. REG. 7-12-2005.
 2,968,098. CORNERSTONE ENERGY. INT. CL. 36. REG. 7-12-2005.

- 2,968,100. BANKERS REALTY. INT. CL. 36. REG. 7-12-2005.
 2,968,101. GLOWMONKEY AND DESIGN. INT. CL. 25. REG. 7-12-2005.
 2,968,104. RACE DIVA. INT. CL. 25. REG. 7-12-2005.
 2,968,107. ELMHURST DAIRY FAT FREE PLUS. INT. CL. 29. REG. 7-12-2005.
 2,968,108. LINKS CONNECTING LEADERSHIP AND VISION. INT. CL. 35. REG. 7-12-2005.
 2,968,109. BOOTY BAR. INT. CL. 41. REG. 7-12-2005.
 2,968,112. WE'VE GOT MORTGAGES FIGURED OUT. INT. CL. 36. REG. 7-12-2005.
 2,968,114. X AND DESIGN. INT. CLS. 9 AND 38. REG. 7-12-2005.
 2,968,116. EASY SERVE (STYLIZED). INT. CL. 29. REG. 7-12-2005.
 2,968,117. DESTINY. INT. CL. 11. REG. 7-12-2005.
 2,968,118. NEVERLAND TOYS. INT. CL. 28. REG. 7-12-2005.
 2,968,119. OTXP (STYLIZED). INT. CLS. 9, 16, 35, 41 AND 42. REG. 7-12-2005.
 2,968,120. SAPPHIRE FAIRY. INT. CL. 28. REG. 7-12-2005.
 2,968,123. CD COLLECTIVE DEVELOPMENT AND DESIGN. INT. CL. 28. REG. 7-12-2005.
 2,968,124. GLACIER STONE. INT. CL. 1. REG. 7-12-2005.
 2,968,125. MAJOR POKER II. INT. CL. 9. REG. 7-12-2005.
 2,968,126. FABULOUS SEVENS. INT. CL. 9. REG. 7-12-2005.
 2,968,127. DYNAMIC CHANNEL ORCHESTRATOR. INT. CL. 9. REG. 7-12-2005.
 2,968,128. P-DCO. INT. CL. 9. REG. 7-12-2005.
 2,968,129. BC BORICUA COLLECTION AND DESIGN. INT. CLS. 25 AND 35. REG. 7-12-2005.
 2,968,130. KILUVA AND DESIGN. INT. CL. 5. REG. 7-12-2005.
 2,968,131. X SPOT. INT. CLS. 9, 10, 16 AND 41. REG. 7-12-2005.
 2,968,132. JETDIRECT. INT. CL. 39. REG. 7-12-2005.
 2,968,133. LODH. INT. CL. 36. REG. 7-12-2005.
 2,968,135. K (STYLIZED). INT. CL. 42. REG. 7-12-2005.
 2,968,136. KÉMIA STANDARD CHARACTER MARK. INT. CL. 42. REG. 7-12-2005.
 2,968,139. BIOCOIL. INT. CL. 9. REG. 7-12-2005.
 2,968,140. YANOCAMU. INT. CL. 5. REG. 7-12-2005.
 2,968,141. MEGOTAPE. INT. CL. 17. REG. 7-12-2005.
 2,968,145. MEDCLOSE. INT. CL. 10. REG. 7-12-2005.
 2,968,147. OPPOSITE APPROACH AND DESIGN. INT. CL. 41. REG. 7-12-2005.
 2,968,148. JALOUSIE. INT. CL. 25. REG. 7-12-2005.
 2,968,153. SAPIAS. INT. CL. 42. REG. 7-12-2005.
 2,968,158. MISCELLANEOUS DESIGN. INT. CLS. 25 AND 35. REG. 7-12-2005.
 2,968,160. DARIO FARRUCCI DESIGNS AND DESIGN. INT. CL. 21. REG. 7-12-2005.
 2,968,161. MMODE. INT. CL. 9. REG. 7-12-2005.
 2,968,162. SEABROOK. INT. CL. 35. REG. 7-12-2005.
 2,968,164. TRACKEASE. INT. CLS. 5 AND 10. REG. 7-12-2005.
 2,968,165. FORGEHOUSE. INT. CL. 9. REG. 7-12-2005.
 2,968,166. HOT RYDE. INT. CL. 28. REG. 7-12-2005.
 2,968,167. POWER PIPES. INT. CL. 28. REG. 7-12-2005.
 2,968,168. KEYNOTE TRAFFIC PERSPECTIVE. INT. CL. 42. REG. 7-12-2005.
 2,968,171. RSP ENGINEERED. INT. CL. 19. REG. 7-12-2005.
 2,968,172. WOW! SEE WHAT A DOLLAR BUYS. INT. CL. 35. REG. 7-12-2005.
 2,968,173. CSD-TV. INT. CLS. 38 AND 41. REG. 7-12-2005.
 2,968,177. CASELINE. INT. CL. 9. REG. 7-12-2005.
 2,968,178. DOUBLE IMPACT. INT. CL. 3. REG. 7-12-2005.
 2,968,180. BRAINY BABY. INT. CL. 35. REG. 7-12-2005.
 2,968,181. BCBGIRLS. INT. CL. 18. REG. 7-12-2005.
 2,968,182. THE ELAN AWARDS. INT. CL. 41. REG. 7-12-2005.
 2,968,184. FX M-14. INT. CL. 32. REG. 7-12-2005.
 2,968,188. MOLECULAR DIAMOND TECHNOLOGIES. INT. CL. 42. REG. 7-12-2005.
 2,968,189. MOLECULAR DIAMOND. INT. CL. 42. REG. 7-12-2005.
 2,968,195. VENUE. INT. CL. 35. REG. 7-12-2005.
 2,968,197. MISCELLANEOUS DESIGN. INT. CL. 28. REG. 7-12-2005.
 2,968,198. REEL BIOGRAPHY. INT. CL. 41. REG. 7-12-2005.
 2,968,199. CLASSIC SCIENCE. INT. CL. 9. REG. 7-12-2005.
 2,968,200. THRU (STYLIZED). INT. CL. 25. REG. 7-12-2005.
 2,968,202. MING DYNASTY. INT. CL. 25. REG. 7-12-2005.
 2,968,203. TIGHTEN UP. INT. CL. 3. REG. 7-12-2005.
 2,968,208. LEMUR'S LEGACY. INT. CLS. 14, 16, 25 AND 28. REG. 7-12-2005.
 2,968,209. IMAR. INT. CL. 25. REG. 7-12-2005.
 2,968,211. URBANSPRAY. INT. CL. 3. REG. 7-12-2005.
 2,968,214. UPLANDER. INT. CL. 12. REG. 7-12-2005.
 2,968,218. SCRUBS PLACE AND DESIGN. INT. CL. 25. REG. 7-12-2005.
 2,968,223. PHEN-DES 8+8 HERBICIDE. INT. CL. 5. REG. 7-12-2005.
 2,968,225. THERE'S ONLY ONE THING MORE RELENTLESS THAN COLORECTAL CANCER. YOU. INT. CL. 16. REG. 7-12-2005.
 2,968,230. FUZE LEMONAID. INT. CL. 32. REG. 7-12-2005.
 2,968,232. POWER BALLS. INT. CL. 30. REG. 7-12-2005.
 2,968,233. BLUE RIDGE SPORTS AND DESIGN. INT. CL. 18. REG. 7-12-2005.
 2,968,241. WIZARD ANIME INSIDER. INT. CL. 16. REG. 7-12-2005.
 2,968,243. MORPHIC AND DESIGN. INT. CL. 25. REG. 7-12-2005.
 2,968,246. ACTIONCHEM. INT. CL. 3. REG. 7-12-2005.
 2,968,247. DELTA STITCH EFFECTS. INT. CL. 16. REG. 7-12-2005.
 2,968,248. OPTRIX. INT. CL. 9. REG. 7-12-2005.
 2,968,251. DREAM. INT. CL. 12. REG. 7-12-2005.
 2,968,255. FREE SPIRITS. INT. CL. 9. REG. 7-12-2005.
 2,968,256. CUBICLE VIEW. INT. CL. 20. REG. 7-12-2005.
 2,968,258. C#BUILDER. INT. CLS. 9, 41 AND 42. REG. 7-12-2005.
 2,968,259. E-BAR AND DESIGN. INT. CLS. 29 AND 30. REG. 7-12-2005.
 2,968,262. MISCELLANEOUS DESIGN. INT. CL. 36. REG. 7-12-2005.
 2,968,263. PHOTOFIGHTER. INT. CL. 9. REG. 7-12-2005.
 2,968,265. TOURNANTE. INT. CL. 9. REG. 7-12-2005.
 2,968,266. FLOWCAST. INT. CLS. 9, 35, 38, 41 AND 42. REG. 7-12-2005.
 2,968,268. YO GIRL!. INT. CL. 24. REG. 7-12-2005.
 2,968,270. TIMWORLD. INT. CL. 1. REG. 7-12-2005.
 2,968,273. MONTCLAIRE. INT. CL. 19. REG. 7-12-2005.
 2,968,274. SELECTIVE RETENTION. INT. CL. 10. REG. 7-12-2005.
 2,968,276. JOBASIC (STYLIZED). INT. CL. 35. REG. 7-12-2005.
 2,968,277. CASA DESIGN ITALIAN LIFESTYLE AND DESIGN. INT. CL. 20. REG. 7-12-2005.
 2,968,279. DOUBLE BRIGHT. INT. CL. 11. REG. 7-12-2005.
 2,968,282. EMPOWERING NETWORK PROFESSIONALS. INT. CL. 9. REG. 7-12-2005.
 2,968,284. MISCELLANEOUS DESIGN. INT. CL. 36. REG. 7-12-2005.
 2,968,287. ARRIVAL SURVIVAL KIT. INT. CL. 35. REG. 7-12-2005.
 2,968,288. RADIUS KING. INT. CL. 8. REG. 7-12-2005.
 2,968,289. BLIND MARK. INT. CL. 9. REG. 7-12-2005.
 2,968,290. REALTONES. INT. CL. 9. REG. 7-12-2005.
 2,968,291. KAMIKAZI KOOLER. INT. CL. 3. REG. 7-12-2005.
 2,968,299. INTEGRATION 4.0 INC. (STYLIZED). INT. CL. 42. REG. 7-12-2005.
 2,968,302. MISCELLANEOUS DESIGN. INT. CLS. 9 AND 25. REG. 7-12-2005.
 2,968,303. COMFORTSHIELD. INT. CL. 19. REG. 7-12-2005.
 2,968,305. POCKETELT. INT. CL. 9. REG. 7-12-2005.
 2,968,306. DAD IN TRAINING. INT. CL. 25. REG. 7-12-2005.
 2,968,308. PUDDLES LIMITED AND DESIGN. INT. CL. 25. REG. 7-12-2005.
 2,968,314. HIBERNATE AND DESIGN. INT. CL. 25. REG. 7-12-2005.
 2,968,315. EPISTREAM AND DESIGN. INT. CL. 35. REG. 7-12-2005.
 2,968,316. ELLIS. INT. CL. 28. REG. 7-12-2005.
 2,968,318. RUDE TUDE. INT. CL. 28. REG. 7-12-2005.
 2,968,319. SCENTS OF STYLE. INT. CL. 28. REG. 7-12-2005.

- 2,968,320. BRYANT. INT. CL. 28. REG. 7-12-2005.
 2,968,321. REDHOUSE AND DESIGN. INT. CL. 33. REG. 7-12-2005.
 2,968,323. TWISTERSIZER. INT. CL. 28. REG. 7-12-2005.
 2,968,325. SCRAPPYCHIC. INT. CL. 16. REG. 7-12-2005.
 2,968,326. FERRICELLI. INT. CL. 25. REG. 7-12-2005.
 2,968,327. SABLE. INT. CL. 16. REG. 7-12-2005.
 2,968,329. WE'RE ALL ABOUT YOU. INT. CL. 36. REG. 7-12-2005.
 2,968,332. PROVENCE RESORT (STYLIZED). INT. CL. 43. REG. 7-12-2005.
 2,968,333. PANOLIVO AND DESIGN. INT. CLS. 35 AND 43. REG. 7-12-2005.
 2,968,334. LASR DIRECT. INT. CL. 36. REG. 7-12-2005.
 2,968,337. NUPUR FOLK DANCE. INT. CL. 41. REG. 7-12-2005.
 2,968,341. GO CRAZY FOLKS GO CRAZY! STANDARD CHARACTER MARK. INT. CL. 13. REG. 7-12-2005.
 2,968,342. THROMBASKET. INT. CL. 10. REG. 7-12-2005.
 2,968,343. PGP AND DESIGN. INT. CL. 9. REG. 7-12-2005.
 2,968,344. THE VILLAGE OF AWESOME. INT. CL. 16. REG. 7-12-2005.
 2,968,345. THE VILLAGE OF AWESOME. INT. CL. 28. REG. 7-12-2005.
 2,968,346. THE VILLAGE OF AWESOME. INT. CL. 41. REG. 7-12-2005.
 2,968,347. CAPITAL ONE | AUTO FINANCE (STYLIZED). INT. CL. 36. REG. 7-12-2005.
 2,968,348. WE ARE A TRADITIONALLY WHOLESOME COMPANY. INT. CL. 3. REG. 7-12-2005.
 2,968,349. WE ARE A TRADITIONALLY WHOLESOME COMPANY. INT. CL. 9. REG. 7-12-2005.
 2,968,350. VILLA REALE. INT. CL. 35. REG. 7-12-2005.
 2,968,351. IOTTA SHOP!. INT. CLS. 14, 16, 21 AND 25. REG. 7-12-2005.
 2,968,354. URBAN SAMURAI. INT. CL. 25. REG. 7-12-2005.
 2,968,355. JOYEUX. INT. CL. 28. REG. 7-12-2005.
 2,968,356. SWEETGRASS. INT. CLS. 35 AND 42. REG. 7-12-2005.
 2,968,357. ROROTON AND DESIGN. INT. CL. 9. REG. 7-12-2005.
 2,968,358. DE DANIEL ESPINOSA AND DESIGN. INT. CL. 35. REG. 7-12-2005.
 2,968,362. HAPPY D.. INT. CL. 28. REG. 7-12-2005.
 2,968,363. WIZEFEST. INT. CL. 41. REG. 7-12-2005.
 2,968,364. OPTIONSFEED. INT. CL. 36. REG. 7-12-2005.
 2,968,366. THE OTHER WWW. INT. CL. 44. REG. 7-12-2005.
 2,968,370. AURORA. INT. CL. 9. REG. 7-12-2005.
 2,968,375. VIAMOTO. INT. CLS. 9 AND 38. REG. 7-12-2005.
 2,968,376. NEWCHARGE (STYLIZED). INT. CL. 30. REG. 7-12-2005.
 2,968,377. MAX-VIZ AND DESIGN. INT. CL. 42. REG. 7-12-2005.
 2,968,379. WILD WAVES. INT. CL. 28. REG. 7-12-2005.
 2,968,382. POWERSHUFFLE. INT. CL. 28. REG. 7-12-2005.
 2,968,383. KNOW YOUR CONDITION. INT. CLS. 16 AND 44. REG. 7-12-2005.
 2,968,386. PFP. INT. CL. 44. REG. 7-12-2005.
 2,968,387. PFP (STYLIZED). INT. CL. 44. REG. 7-12-2005.
 2,968,388. SUIVIVE. INT. CL. 41. REG. 7-12-2005.
 2,968,389. OVERFLOE. INT. CL. 41. REG. 7-12-2005.
 2,968,390. TOPAZ. INT. CL. 30. REG. 7-12-2005.
 2,968,393. GARAGE CRAFT. INT. CLS. 35, 37 AND 42. REG. 7-12-2005.
 2,968,395. YET YOUR ENERGY TONIC AND DESIGN. INT. CL. 32. REG. 7-12-2005.
 2,968,396. WORK HARD, PLAY HARD. DRINK HERC.. INT. CL. 5. REG. 7-12-2005.
 2,968,399. GHMONITOR. INT. CL. 44. REG. 7-12-2005.
 2,968,400. PRESSTO!. INT. CL. 16. REG. 7-12-2005.
 2,968,402. PN (STYLIZED). INT. CL. 5. REG. 7-12-2005.
 2,968,403. CHRONONUTRITION. INT. CLS. 35 AND 44. REG. 7-12-2005.
 2,968,404. PUZZLETRAINIA. INT. CL. 28. REG. 7-12-2005.
 2,968,406. CANDY GREETINGS. INT. CLS. 30 AND 35. REG. 7-12-2005.
 2,968,411. BEAUTE (STYLIZED). INT. CL. 25. REG. 7-12-2005.
 2,968,419. BEN & SONS. INT. CLS. 9, 16 AND 18. REG. 7-12-2005.
 2,968,420. ERIC MORGAN AND DESIGN. INT. CL. 20. REG. 7-12-2005.
 2,968,421. WHO'S WHO AMONG AMERICAN HIGH SCHOOL STUDENTS ESTABLISHED 1967 AND DESIGN. INT. CL. 16. REG. 7-12-2005.
 2,968,425. KRETSCHMAR PREMIER SMOKED HAM. INT. CL. 29. REG. 7-12-2005.
 2,968,426. IDESIGN. INT. CL. 9. REG. 7-12-2005.
 2,968,427. RESPONSIBLE RISK. REMARKABLE RETURNS.. INT. CL. 36. REG. 7-12-2005.
 2,968,428. ARM ANGEL. INT. CL. 21. REG. 7-12-2005.
 2,968,431. MCKINLEY SPRINGS. INT. CL. 33. REG. 7-12-2005.
 2,968,436. BIRDSTEP INTELLIGENT MOBILE IP. INT. CL. 9. REG. 7-12-2005.
 2,968,440. EASY CAFFÈ. INT. CL. 30. REG. 7-12-2005.
 2,968,441. MORGAN STANLEY CLIENTONE AND DESIGN. INT. CL. 36. REG. 7-12-2005.
 2,968,442. THE TERMINAL THAT TALKS. INT. CL. 9. REG. 7-12-2005.
 2,968,444. BD.ID. INT. CL. 9. REG. 7-12-2005.
 2,968,445. GORDY'S CHUNKS 'N' CHIPS. INT. CL. 4. REG. 7-12-2005.
 2,968,447. STI LABS. INT. CL. 5. REG. 7-12-2005.
 2,968,448. SOXA ACCELERATOR. INT. CLS. 9, 41 AND 42. REG. 7-12-2005.
 2,968,449. O SOY RICE VINEGAR. INT. CL. 30. REG. 7-12-2005.
 2,968,450. AWARE - ANIMAL WELFARE ASSURANCE REVIEW & EVALUATION. INT. CLS. 41 AND 44. REG. 7-12-2005.
 2,968,452. SULTAN'S ART DEDICATED HANDS AND DESIGN. INT. CL. 35. REG. 7-12-2005.
 2,968,456. NIFORMIS MADE IN ITALY AND DESIGN. INT. CL. 25. REG. 7-12-2005.
 2,968,458. EGG-CENTIVES. INT. CL. 28. REG. 7-12-2005.
 2,968,459. STONEGROUND. INT. CL. 25. REG. 7-12-2005.
 2,968,462. HOME DEPOT CENTER THE HOME DEPOT AND DESIGN. INT. CL. 21. REG. 7-12-2005.
 2,968,465. PARTY LIKE A PRO. INT. CL. 16. REG. 7-12-2005.
 2,968,467. DUAL GUARD. INT. CL. 7. REG. 7-12-2005.
 2,968,470. NATRAL. INT. CL. 3. REG. 7-12-2005.
 2,968,472. DOWNTOWN ELECTRIC FIREPLACE COMPANY. INT. CL. 35. REG. 7-12-2005.
 2,968,473. BODYPLAY. INT. CL. 44. REG. 7-12-2005.
 2,968,474. ORBITEETHER AND DESIGN. INT. CL. 10. REG. 7-12-2005.
 2,968,475. HILL'S SCIENCE DIET ADVANCED PROTECTION VETERINARIAN RECOMMENDED AND DESIGN. INT. CL. 31. REG. 7-12-2005.
 2,968,477. AUTOPROS EMPLOYMENT AGENCY AND DESIGN. INT. CL. 35. REG. 7-12-2005.
 2,968,481. E-CMP. INT. CL. 7. REG. 7-12-2005.
 2,968,482. PEAKS. INT. CL. 35. REG. 7-12-2005.
 2,968,484. FIRST EDITION COMMUNITY CREDIT UNION. INT. CL. 36. REG. 7-12-2005.
 2,968,487. ROMANTICSINGLES.COM. INT. CL. 45. REG. 7-12-2005.
 2,968,491. TASTE OF THE VINE AND DESIGN. INT. CL. 41. REG. 7-12-2005.
 2,968,493. CITRICO VIBRANTE. INT. CL. 32. REG. 7-12-2005.
 2,968,494. FUN PLACE. SERIOUS FOOD.. INT. CL. 35. REG. 7-12-2005.
 2,968,495. FUN PLACE. SERIOUS FOOD.. INT. CL. 43. REG. 7-12-2005.
 2,968,496. TOPAMAX. INT. CL. 5. REG. 7-12-2005.
 2,968,497. MISCELLANEOUS DESIGN. INT. CL. 35. REG. 7-12-2005.
 2,968,498. MISCELLANEOUS DESIGN. INT. CL. 5. REG. 7-12-2005.
 2,968,499. JARDÍN CAMPESTRE. INT. CL. 3. REG. 7-12-2005.

- 2,968,500. JUTHANI & COX FIRST AID FOR MENTAL HEALTH. INT. CL. 41. REG. 7-12-2005.
- 2,968,506. THE PERFECT RIB. INT. CL. 29. REG. 7-12-2005.
- 2,968,508. WOOLRICH. INT. CL. 24. REG. 7-12-2005.
- 2,968,514. PIXPO. INT. CL. 9. REG. 7-12-2005.
- 2,968,517. ORACLE 10G. INT. CL. 9. REG. 7-12-2005.
- 2,968,521. LEGACY MAIL. INT. CL. 35. REG. 7-12-2005.
- 2,968,522. SOFT-EZE. INT. CL. 20. REG. 7-12-2005.
- 2,968,526. PEACE ONE HEART AT A TIME. INT. CLS. 9, 16 AND 41. REG. 7-12-2005.
- 2,968,528. 24 SEVEN. INT. CL. 28. REG. 7-12-2005.
- 2,968,529. ARIA. INT. CL. 10. REG. 7-12-2005.
- 2,968,531. BOYLSTON STREET FUND. INT. CL. 36. REG. 7-12-2005.
- 2,968,534. TENACITY. INT. CLS. 35, 37 AND 42. REG. 7-12-2005.
- 2,968,535. ENERGYSTAT AND DESIGN. INT. CL. 9. REG. 7-12-2005.
- 2,968,537. MAGIC POWERS. INT. CL. 28. REG. 7-12-2005.
- 2,968,542. INTERNET SWEEPER. INT. CL. 9. REG. 7-12-2005.
- 2,968,549. MAGICAL CREATURES. INT. CL. 28. REG. 7-12-2005.
- 2,968,551. HONEYSUCKLE HILL. INT. CL. 26. REG. 7-12-2005.
- 2,968,552. ROUZE. INT. CL. 42. REG. 7-12-2005.
- 2,968,554. MASSAGEPLAY. INT. CL. 44. REG. 7-12-2005.
- 2,968,555. DOES YOUR LEARNING MAKE A DIFFERENCE?. INT. CLS. 9, 16 AND 41. REG. 7-12-2005.
- 2,968,556. SZIO. INT. CL. 9. REG. 7-12-2005.
- 2,968,557. FIREPOND. INT. CLS. 9 AND 42. REG. 7-12-2005.
- 2,968,558. MODELSTREAM. INT. CL. 9. REG. 7-12-2005.
- 2,968,559. CITY OF LONDON BY FERRELL REED. INT. CL. 25. REG. 7-12-2005.
- 2,968,561. WHOOPSIE. INT. CL. 25. REG. 7-12-2005.
- 2,968,562. DOUBLEWIDE. INT. CL. 9. REG. 7-12-2005.
- 2,968,565. JOIE DE VIVRE. INT. CL. 16. REG. 7-12-2005.
- 2,968,566. INTUITIVE KNEADS (STYLIZED). INT. CL. 44. REG. 7-12-2005.
- 2,968,570. 3PR. INT. CL. 35. REG. 7-12-2005.
- 2,968,572. XFRAME. INT. CL. 9. REG. 7-12-2005.
- 2,968,574. TASTE THE JUICY CRUNCH. INT. CL. 29. REG. 7-12-2005.
- 2,968,575. JOIA. INT. CL. 25. REG. 7-12-2005.
- 2,968,576. IT'S WHAT'S HOT IN PAIN RELIEF. INT. CL. 5. REG. 7-12-2005.
- 2,968,578. GAMEPLAN FOR AGING. INT. CLS. 9, 16 AND 41. REG. 7-12-2005.
- 2,968,579. UPUBLISHER. INT. CL. 9. REG. 7-12-2005.
- 2,968,580. CITY OF LONDON BY FERRELL REED. INT. CL. 25. REG. 7-12-2005.
- 2,968,584. PAGEANTRY PERFUME. INT. CL. 3. REG. 7-12-2005.
- 2,968,585. ALUMI DEUCE STANDARD CHARACTER MARK. INT. CL. 28. REG. 7-12-2005.
- 2,968,587. POPSICLE. INT. CL. 14. REG. 7-12-2005.
- 2,968,588. CREAMSICLE. INT. CL. 14. REG. 7-12-2005.
- 2,968,589. TOMLIN AIR. INT. CL. 39. REG. 7-12-2005.
- 2,968,590. FRESHNESS VERIFIED. INT. CLS. 29, 31 AND 32. REG. 7-12-2005.
- 2,968,592. AYHAN'S MEDITERRANEAN MENU PLANS. INT. CL. 44. REG. 7-12-2005.
- 2,968,595. SIPGATE AND DESIGN. INT. CL. 38. REG. 7-12-2005.
- 2,968,597. CASUAL FLAVORS BY STONEWOOD STANDARD CHARACTER MARK. INT. CL. 16. REG. 7-12-2005.
- 2,968,598. CHEF TIM'S GRINGO SALSA. INT. CL. 30. REG. 7-12-2005.
- 2,968,601. TCP LINDA. INT. CL. 9. REG. 7-12-2005.
- 2,968,605. FUSE AMPLIFIED GUIDE. INT. CL. 41. REG. 7-12-2005.
- 2,968,606. LIQUID SHADOW. INT. CL. 42. REG. 7-12-2005.
- 2,968,608. UP OFF. INT. CL. 9. REG. 7-12-2005.
- 2,968,609. LOWCO. INT. CL. 35. REG. 7-12-2005.
- 2,968,610. KCSOURCELINK AND DESIGN. INT. CL. 35. REG. 7-12-2005.
- 2,968,612. CM&C SECRET. INT. CL. 5. REG. 7-12-2005.
- 2,968,613. EQUUS. LTD AND DESIGN. INT. CLS. 18 AND 20. REG. 7-12-2005.
- 2,968,614. INTELLABOX. INT. CLS. 16, 35 AND 42. REG. 7-12-2005.
- 2,968,617. SCHOOL'S HARD, YOUR BED SHOULDN'T BE. INT. CL. 20. REG. 7-12-2005.
- 2,968,618. PUT YOUR HEALTHFIRST. INT. CL. 10. REG. 7-12-2005.
- 2,968,619. SEVEN OAKS PRESS. INT. CL. 41. REG. 7-12-2005.
- 2,968,621. BLACK RAM ENGINEERING. INT. CL. 42. REG. 7-12-2005.
- 2,968,622. TRUE3D. INT. CL. 16. REG. 7-12-2005.
- 2,968,623. CRAZY HORSE. INT. CL. 34. REG. 7-12-2005.
- 2,968,627. FANCY FLOURS AND DESIGN. INT. CLS. 16, 21, 30 AND 35. REG. 7-12-2005.
- 2,968,628. PIECES OF PLACES. INT. CL. 35. REG. 7-12-2005.
- 2,968,629. SAFE RIDERS! LOVE THIS PLANET. INT. CL. 35. REG. 7-12-2005.
- 2,968,630. DILIGENT TECHNOLOGIES. INT. CLS. 9 AND 42. REG. 7-12-2005.
- 2,968,631. EZP. INT. CL. 26. REG. 7-12-2005.
- 2,968,632. WINLITE. INT. CL. 19. REG. 7-12-2005.
- 2,968,634. CARLETON HOUSE. INT. CL. 16. REG. 7-12-2005.
- 2,968,635. PERSPIRATION GUARD STANDARD CHARACTER MARK. INT. CL. 25. REG. 7-12-2005.
- 2,968,636. WE PUT THE HUMAN BACK IN HUMAN RESOURCES STANDARD CHARACTER MARK. INT. CL. 35. REG. 7-12-2005.
- 2,968,637. WINGMAN STANDARD CHARACTER MARK. INT. CL. 5. REG. 7-12-2005.
- 2,968,638. HOLY MACKERELS STANDARD CHARACTER MARK. INT. CL. 41. REG. 7-12-2005.
- 2,968,639. WACKY WATER STANDARD CHARACTER MARK. INT. CL. 28. REG. 7-12-2005.
- 2,968,641. MISCELLANEOUS DESIGN. INT. CL. 39. REG. 7-12-2005.
- 2,968,643. THE EYE BALL STANDARD CHARACTER MARK. INT. CL. 28. REG. 7-12-2005.
- 2,968,644. TEACHERS N TOUCH - T N T - A COMMUNICATION EXPLOSION AND DESIGN. INT. CL. 16. REG. 7-12-2005.
- 2,968,649. RIDE THE OUTLAW TRAIL STANDARD CHARACTER MARK. INT. CL. 28. REG. 7-12-2005.
- 2,968,650. S SUNSHINE AND DESIGN. INT. CL. 18. REG. 7-12-2005.
- 2,968,651. MOBILE2MARKET STANDARD CHARACTER MARK. INT. CL. 42. REG. 7-12-2005.
- 2,968,653. DELTASYM STANDARD CHARACTER MARK. INT. CL. 42. REG. 7-12-2005.
- 2,968,661. EQUESTRA STANDARD CHARACTER MARK. INT. CL. 10. REG. 7-12-2005.
- 2,968,665. PEOPLE FIRST STANDARD CHARACTER MARK. INT. CL. 12. REG. 7-12-2005.
- 2,968,666. LINELOCK STANDARD CHARACTER MARK. INT. CL. 25. REG. 7-12-2005.
- 2,968,676. STEVIZYME STANDARD CHARACTER MARK. INT. CL. 5. REG. 7-12-2005.
- 2,968,679. CLEARCHECK STANDARD CHARACTER MARK. INT. CL. 36. REG. 7-12-2005.
- 2,968,683. RAZZLE BLUE BLITZ STANDARD CHARACTER MARK. INT. CL. 29. REG. 7-12-2005.
- 2,968,699. SHANKZ STANDARD CHARACTER MARK. INT. CL. 41. REG. 7-12-2005.
- 2,968,800. PACIFIC LIFE HOLIDAY BOWL AND DESIGN. INT. CL. 25. REG. 7-12-2005.
- 2,968,802. STREAM. INT. CL. 17. REG. 7-12-2005.
- 2,968,803. MEUSSDOERFFER-MALZ AND DESIGN. INT. CL. 31. REG. 7-12-2005.
- 2,968,807. FILLMORE ST. BREWERY AND DESIGN. INT. CL. 32. REG. 7-12-2005.
- 2,968,811. AYHAN'S FAMOUS. INT. CLS. 29 AND 30. REG. 7-12-2005.
- 2,968,812. IMPERATOR. INT. CL. 41. REG. 7-12-2005.
- 2,968,813. UNIRE. INT. CL. 36. REG. 7-12-2005.
- 2,968,814. CONQUERER. INT. CL. 9. REG. 7-12-2005.
- 2,968,819. THE ART LAW CENTER. INT. CLS. 16, 36, 41 AND 42. REG. 7-12-2005.

- 2,970,155. ZINGTIME STANDARD CHARACTER MARK. INT. CLS. 9, 35 AND 38. REG. 7-19-2005.
- 2,971,521. KBC HELMETS AND DESIGN. INT. CL. 25 ONLY. REG. 7-19-2005.
- 2,972,546. L3 (STYLIZED). INT. CL. 3. REG. 7-19-2005.
- 2,976,723. GOD CHILD. INT. CL. 3. REG. 7-26-2005.
- 2,977,021. CARTWHEELS AND DESIGN. INT. CL. 28. REG. 7-26-2005.
- 2,979,750. INTERVIDEO INSTANTON (STYLIZED). INT. CL. 9. REG. 7-26-2005.
- 3,038,687. ARC. INT. CLS. 12 AND 40 ONLY. REG. 1-10-2006.
- 3,038,762. SIGNINFO. INT. CL. 42 ONLY. REG. 1-10-2006.
- 3,039,814. PPS. INT. CLS. 9, 12 AND 40 ONLY. REG. 1-10-2006.
- 3,039,941. CONTROL CENTER SOLUTIONS. INT. CL. 41 ONLY. REG. 1-10-2006.
- 3,039,970. MISCELLANEOUS DESIGN. INT. CL. 42 ONLY. REG. 1-10-2006.
- 3,040,336. MISCELLANEOUS DESIGN. INT. CL. 25 ONLY. REG. 1-10-2006.
- 3,042,100. NUVIM. INT. CL. 32 ONLY. REG. 1-10-2006.
- 3,042,415. RECOLLECTIONS. INT. CLS. 35 AND 41 ONLY. REG. 1-10-2006.
- 3,042,909. RHCA STANDARD CHARACTER MARK. INT. CL. 16 ONLY. REG. 1-10-2006.
- 3,043,315. MISCELLANEOUS DESIGN. INT. CLS. 29, 30 AND 32 ONLY. REG. 1-17-2006.
- 3,050,864. C.O.L.L.E.C.T.I.V.E. STANDARD CHARACTER MARK. INT. CL. 25 ONLY. REG. 1-24-2006.
- 3,057,084. AMAZING BABY. INT. CLS. 24 AND 25 ONLY. REG. 2-7-2006.
- 3,058,401. HIGHDISTANCE STANDARD CHARACTER MARK. INT. CLS. 9, 10, 12, 17, 19, 22, 24, 25, 28 AND 42 ONLY. REG. 2-14-2006.
- 3,138,335. ALEBRA STANDARD CHARACTER MARK. INT. CL. 45 ONLY. REG. 9-5-2006.
- 3,147,608. M (STYLIZED). INT. CLS. 16 AND 35 ONLY. REG. 9-26-2006.
- 3,147,749. ALEBRA AND DESIGN. INT. CL. 45 ONLY. REG. 9-26-2006.
- 3,160,569. CHOCOA STANDARD CHARACTER MARK. INT. CL. 35 ONLY. REG. 10-17-2006.
- 3,164,685. POLYSOFT PRODUCTS INC. STANDARD CHARACTER MARK. INT. CLS. 16 AND 21 ONLY. REG. 10-31-2006.
- 3,174,209. SDSU AND DESIGN. INT. CL. 25 ONLY. REG. 11-21-2006.

SECTION 71

- 2,967,215. CHÉRIE LINE (STYLIZED). INT. CL. 25. REG. 7-12-2005.
- 2,967,217. SWISS IMPLANT AND DESIGN. INT. CL. 10. REG. 7-12-2005.
- 2,967,221. QUEST OF VENTURE STANDARD CHARACTER MARK. INT. CL. 33. REG. 7-12-2005.
- 2,967,222. ENIGMA STANDARD CHARACTER MARK. INT. CLS. 1, 2 AND 17. REG. 7-12-2005.
- 2,967,223. PICUS STANDARD CHARACTER MARK. INT. CL. 1. REG. 7-12-2005.
- 2,967,225. DJEMBE STANDARD CHARACTER MARK. INT. CL. 34. REG. 7-12-2005.
- 2,967,227. VITAMONT (STYLIZED). INT. CLS. 29, 30 AND 32. REG. 7-12-2005.
- 2,967,228. MISCELLANEOUS DESIGN. INT. CLS. 1, 5, 9 AND 10. REG. 7-12-2005.
- 2,967,230. DESIGNERS REMIX COLLECTION AND DESIGN. INT. CL. 25. REG. 7-12-2005.
- 2,967,231. MAXIPACK STANDARD CHARACTER MARK. INT. CL. 22. REG. 7-12-2005.
- 2,967,235. DENPROANIMAL (STYLIZED). INT. CLS. 5 AND 31. REG. 7-12-2005.

INADVERTENTLY ISSUED REGISTRATION NUMBERS

- 4,094,997. POCZTA KWIATOWA STANDARD CHARACTER MARK. INT. CLS. 35, 39 AND 42. REG. 2-7-2012. RESTORED TO SN 77-893,525.

* * * * *

TRADEMARK REGISTRATIONS AMENDED, CORRECTED, ETC.

The designation "U.S. Cl." appearing in this section refers to the U.S. class in effect prior to Sep. 1, 1973 rather than the international class which applies to applications filed on or after that date. For adoption of international classification see notice in the OFFICIAL GAZETTE of Jun. 26, 1973 (911 O.G. TM 210).

Any change to the registration will be indicated at the bottom of each entry under ELEMENTS AMENDED, CORRECTED OR RESTRICTED. With the exception of changes to the goods and services, additions to the registration will appear in asterisks and deletions of the registration will appear in brackets. Elements which are only changed will be listed with no punctuation. As to the goods/services statement, amendments to the goods/services will appear in asterisks and deletions will appear in brackets. In addition if any change to the goods/services occurs, the element "Goods/Services" will be listed under ELEMENTS AMENDED, CORRECTED OR RESTRICTED.

85,150. REG. 1-30-1912. JOHNSON & JOHNSON (NEW JERSEY CORPORATION) ONE JOHNSON & JOHNSON PLAZA, NEW BRUNSWICK, NJ, 08933, SN 71-054,170. FILED 1-30-1911. PRINCIPAL REGISTER.

2,273,051. REG. 8-24-1999. FOODHANDLER INC. (NEW YORK CORPORATION) 514 GRAND BOULEVARD, WESTBURY, NY, 11590, SN 75-418,190. FILED 1-15-1998. PRINCIPAL REGISTER.

LISTERINE

THE MARK CONSISTS OF STANDARD CHARACTERS WITHOUT CLAIM TO ANY PARTICULAR FONT, STYLE, SIZE, OR COLOR.

INT. CL. 5/U.S. CL. 18

FOR ANTISEPTIC FOR MEDICINAL USE, PERSONAL HYGIENE, AND TOILET.

FIRST USE 5-1-1881; IN COMMERCE 5-1-1881.

ELEMENTS AMENDED
MARK

SAFETYGRIP

INT. CL. 21/U.S. CLS. 2, 13, 23, 29, 30, 33, 40 AND 50
FOR TEXTURED LATEX DISPOSABLE GLOVES FOR GENERAL USE.

FIRST USE 4-0-1998; IN COMMERCE 4-0-1998.

ELEMENTS CORRECTED
MARK

1,179,644. REG. 11-24-1981. SEARS BRANDS, LLC (ILLINOIS LIMITED LIABILITY COMPANY) 3333 BEVERLY ROAD, HOFFMAN ESTATES, IL, 60179, SN 73-279,158. FILED 9-24-1980. PRINCIPAL REGISTER.

2,534,959. REG. 1-29-2002. CORRIGO INCORPORATED (CALIFORNIA CORPORATION) 8245 SW TUALATIN SHERWOOD ROAD, TUALATIN, OR, 97062, SN 78-010,955. FILED 6-2-2000. PRINCIPAL REGISTER.

BLUELIGHT SPECIAL

THE MARK CONSISTS OF STANDARD CHARACTERS WITHOUT CLAIM TO ANY PARTICULAR FONT, STYLE, SIZE, OR COLOR.

INT. CL. 42/U.S. CL. 101

FOR RETAIL VARIETY STORE SERVICES.

FIRST USE 2-0-1963; IN COMMERCE 2-0-1963.

ELEMENTS AMENDED
MARK

CORRIGO

INT. CL. 42/U.S. CLS. 100 AND 101

FOR COMPUTER CONSULTING SERVICES IN THE AREA OF MOBILE ENTERPRISE APPLICATION SOLUTIONS; COMPUTER SOFTWARE DESIGN FOR OTHERS.

FIRST USE 2-1-1999; IN COMMERCE 2-1-1999.

ELEMENTS CORRECTED
OWNER NAME
OWNER ADDRESS

2,537,616. REG. 2-12-2002. FRESH, INC. (DELAWARE CORPORATION) 3/F, 19 EAST 57TH STREET, NEW YORK, NY, 10022. SN 75-786,152. FILED 10-30-1999. PRINCIPAL REGISTER.

SUGAR
eau de parfum

NO CLAIM IS MADE TO THE EXCLUSIVE RIGHT TO USE "EAU DE PARFUM", APART FROM THE MARK AS SHOWN.

INT. CL. 3/U.S. CLS. 1, 4, 6, 50, 51 AND 52
FOR PERFUME, TOILET WATERS.
FIRST USE 1-0-1998; IN COMMERCE 1-0-1998.

ELEMENTS AMENDED
MARK

2,550,290. REG. 3-19-2002. HANS TURCK GMBH & CO. K.G. (FED REP GERMANY KOMMANDITGESELLSCHAFT (KG)) WITZLEBENSTR. 7, 45472 MUELHEIM/RUHR, FED REP GERMANY., SN 75-443,057. FILED 3-2-1998. PRINCIPAL REGISTER.

Q-PAK

INT. CL. 9/U.S. CLS. 21, 23, 26, 36 AND 38
FOR PROXIMITY SENSORS USED ON MACHINE TOOLS AND INDUSTRIAL MACHINERY.
FIRST USE 2-0-1998; IN COMMERCE 2-0-1998.

ELEMENTS CORRECTED
OWNER NAME
ENTITY

2,590,932. REG. 7-9-2002. TRUSTEES OF THE UNIVERSITY OF PENNSYLVANIA, THE (PENNSYLVANIA NON-PROFIT CORPORATION) 133 S. 36TH STREET, SUITE 300, OFFICE OF THE GENERAL COUNSEL, PHILADELPHIA, PA, 19104. SN 76-172,896. FILED 11-29-2000. PRINCIPAL REGISTER.

PennNet

OWNER OF U.S. REG. NOS. 1,747,008, 1,932,068 AND OTHERS.

INT. CL. 38/U.S. CLS. 100, 101 AND 104
FOR COMPUTER SERVICES, NAMELY, PROVIDING ON-LINE ACCESS TO UNIVERSITY E-MAIL AND TO CONNECT STUDENTS ELECTRONICALLY TO EDUCATIONAL RESOURCES NAMELY LIBRARIES, EDUCATIONAL AND GENERAL NEWS DATA BASES, BULLETIN BOARDS, AND COMPUTING FACILITIES; AND PROVIDING ON-LINE ACCESS TO WORLD WIDE COMPUTER NETWORKS.

FIRST USE 0-0-1986; IN COMMERCE 0-0-1986.
INT. CL. 41/U.S. CLS. 100, 101 AND 107

FOR COMPUTER SERVICES, NAMELY, PROVIDING ON-LINE INFORMATION IN THE FIELD OF EDUCATIONAL RESOURCES, NAMELY, LIBRARIES, EDUCATIONAL AND GENERAL NEWS DATA BASES AND COMPUTING FACILITIES VIA GLOBAL COMPUTER NETWORKS .

FIRST USE 0-0-1986; IN COMMERCE 0-0-1986.

ELEMENTS CORRECTED
ENTITY

2,748,385. REG. 8-5-2003. SCHURHAMMER JEWELRY, INC. (MINNESOTA CORPORATION) 131 WEST MAIN STREET, WABASHA, MN, 55981. SN 76-348,006. FILED 12-13-2001. PRINCIPAL REGISTER.

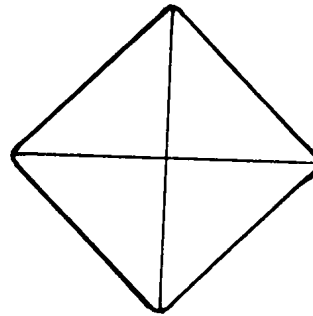

INT. CL. 14/U.S. CLS. 2, 27, 28 AND 50
FOR DIAMONDS.
FIRST USE 2-1-2002; IN COMMERCE 2-1-2002.

ELEMENTS CORRECTED
OWNER NAME

2,801,914. REG. 1-6-2004. WEKA FACHMEDIEN GMBH (FED REP GERMANY CORPORATION) RICHARD-REITZNER-ALLEE 2, 85549 HAAR, FED REP GERMANY., AND NURNBERGMESSE GMBH (FED REP GERMANY CORPORATION) MESSEZENTRUM, 90471 NURNBERG, FED REP GERMANY., SN 76-445,593. FILED 8-27-2002. PRINCIPAL REGISTER.

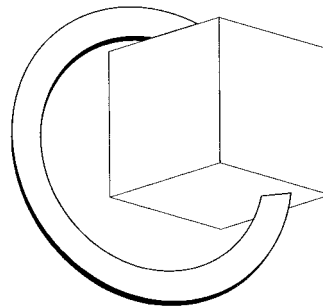

OWNER OF FED REP GERMANY REG. NO. 30220466, DATED 7-12-2002.
INT. CL. 9/U.S. CLS. 21, 23, 26, 36 AND 38

FOR BLANK DATA CARRIERS AND STORAGE DEVICES, NAMELY, CDS, CD-ROMS, FLOPPY DISCS, VIDEOCASSETTES AND AUDIOCASSETTES; RECORDED DATA CARRIERS AND STORAGE DEVICES, NAMELY, CDS, CD-ROMS, DVDS AND FLOPPY DISCS OF COMPUTERS BEARING PRE-RECORDED DATA AND INFORMATION IN THE FIELD OF EMBEDDED TECHNOLOGY AND FAIRS, EXHIBITIONS OR SYMPOSIA IN THE FIELD OF EMBEDDED TECHNOLOGY; PRE-RECORDED VIDEO AND AUDIO CASSETTES FEATURING DATA AND INFORMATION IN THE FIELD OF EMBEDDED TECHNOLOGY AND FAIRS, EXHIBITIONS OR SYMPOSIA IN THE FIELD OF EMBEDDED TECHNOLOGY; DOWNLOADABLE ELECTRONIC PUBLICATIONS IN THE NATURE OF BOOKS, MAGAZINES, NEWSLETTERS, MANUALS, BROCHURES AND LEAFLETS FEATURING EMBEDDED TECHNOLOGY RELATED CONTENT, AND FOR FAIRS, EXHIBITIONS AND SYMPOSIA IN THE FIELD OF EMBEDDED TECHNOLOGY, VIA THE INTERNET AND RECORDED ON COMPUTER MEDIA.

FIRST USE ; IN COMMERCE .

INT. CL. 16/U.S. CLS. 2, 5, 22, 23, 29, 37, 38 AND 50

FOR PRINTED MATTER, NAMELY, BOOKS, MAGAZINES, NEWSLETTERS, MANUALS, BROCHURES, LEAFLETS, PRINTED GUIDES, CATALOGS AND ADDRESS LISTS FEATURING EMBEDDED TECHNOLOGY RELATED CONTENT AND FOR FAIRS, EXHIBITIONS AND SYMPOSIA IN THE FIELD OF EMBEDDED TECHNOLOGY; PRINTED MATTER, NAMELY, BOOKS, MAGAZINES, NEWSLETTERS, MANUALS, BROCHURES, LEAFLETS, PRINTED GUIDES, CATALOGS AND ADDRESS LISTS FEATURING INFORMATIONAL MATERIAL FOR EMBEDDED TECHNOLOGY AND FOR FAIRS, EXHIBITIONS AND SYMPOSIA IN THE FIELD OF EMBEDDED TECHNOLOGY.

FIRST USE ; IN COMMERCE .

INT. CL. 35/U.S. CLS. 100, 101 AND 102

FOR ORGANIZING, ARRANGING AND CONDUCTING OF EXHIBITIONS, AND TRADE FAIRS IN THE FIELD OF ELECTRONICS.

FIRST USE ; IN COMMERCE .

ELEMENTS AMENDED
OWNER ADDRESS

2,935,552. REG. 3-22-2005. VITATECH INTERNATIONAL, INC. (CALIFORNIA CORPORATION) 2832 DOW AVENUE, TUSTIN, CA, 92780, SN 78-252,287. FILED 5-20-2003. PRINCIPAL REGISTER.



OWNER OF U.S. REG. NOS. 1,338,760 AND 1,359,697.
NO CLAIM IS MADE TO THE EXCLUSIVE RIGHT TO USE "INTERNATIONAL, INC.", APART FROM THE MARK AS SHOWN.

INT. CL. 40/U.S. CLS. 100, 103 AND 106

FOR CUSTOM MANUFACTURE OF NUTRITIONAL SUPPLEMENTS.

FIRST USE 9-0-2002; IN COMMERCE 9-0-2002.

ELEMENTS CORRECTED
OWNER NAME

2,982,227. REG. 8-2-2005. CASCO BAY GARDENS, LLC. (MAINE LIMITED LIABILITY COMPANY) 1776 BROADWAY, SOUTH PORTLAND, ME, 04106, SN 78-387,459. FILED 3-19-2004. PRINCIPAL REGISTER.

Lobsterman's CoolKiss

THE MARK CONSISTS OF STANDARD CHARACTERS WITHOUT CLAIM TO ANY PARTICULAR FONT, STYLE, SIZE, OR COLOR.

OWNER OF U.S. REG. NO. 2,626,699.

INT. CL. 3/U.S. CLS. 1, 4, 6, 50, 51 AND 52

FOR NON MEDICATED LIP BALM.

FIRST USE 1-1-2004; IN COMMERCE 3-1-2004.

ELEMENTS CORRECTED
ENTITY

3,036,447. REG. 12-27-2005. CUSTOMSTART L.L.C. (ARIZONA LIMITED LIABILITY COMPANY) 6525 EAST BAR Z LANE, PARADISE VALLEY, AZ, 85253, SN 78-208,991. FILED 1-30-2003. PRINCIPAL REGISTER.

CUSTOMSTART DESIGN

NO CLAIM IS MADE TO THE EXCLUSIVE RIGHT TO USE "DESIGN", APART FROM THE MARK AS SHOWN.

INT. CL. 42/U.S. CLS. 100 AND 101

FOR INTERIOR DESIGN SERVICES, NAMELY INTERIOR DECORATING SERVICES AND INTERIOR DECORATION CONSULTATION.

FIRST USE 9-16-2002; IN COMMERCE 12-23-2002.

ELEMENTS CORRECTED
ENTITY

3,039,590. REG. 1-10-2006. BAYLOR HEALTH CARE SYSTEM (TEXAS NON-PROFIT CORPORATION) 4005 CHURCH STREET, SUITE 300, DALLAS, TX, 75246, SN 76-620,613. FILED 11-12-2004. PRINCIPAL REGISTER.

OUR FLAME BURNS BRIGHT

THE MARK CONSISTS OF STANDARD CHARACTERS WITHOUT CLAIM TO ANY PARTICULAR FONT, STYLE, SIZE, OR COLOR.

INT. CL. 44/U.S. CLS. 100 AND 101

FOR HEALTH CARE AND HOSPITAL SERVICES.

FIRST USE 5-0-2004; IN COMMERCE 5-0-2004.

ELEMENTS CORRECTED
ENTITY

3,140,793. REG. 9-12-2006. GOOGLE INC. (DELAWARE CORPORATION) 1600 AMPHITHEATRE PARKWAY, BUILDING 41, MOUNTAIN VIEW, CA, 94043, SN 76-314,811. FILED 9-18-2001. PRINCIPAL REGISTER.



THE COLOR(S) BLUE, RED, YELLOW, AND GREEN IS/ ARE CLAIMED AS A FEATURE OF THE MARK.

THE MARK CONSISTS OF A STYLIZED VERSION OF THE WORD GOOGLE. THE FIRST LETTER "G" IS BLUE; THE SECOND LETTER "O" IS RED; THE THIRD LETTER "O" IS YELLOW; THE FOURTH LETTER "G" IS BLUE; THE FIFTH LETTER "L" IS GREEN; AND THE SIXTH LETTER "E" IS RED.

INT. CL. 9/U.S. CLS. 21, 23, 26, 36 AND 38

FOR COMPUTER SOFTWARE FOR SEARCHING, COMPILING, INDEXING AND ORGANIZING INFORMATION ON COMPUTER NETWORKS; COMPUTER HARDWARE, COMPUTER SOFTWARE FOR SEARCHING, COMPILING, INDEXING, AND ORGANIZING INFORMATION WITHIN INDIVIDUAL WORKSTATIONS AND PERSONAL COMPUTERS; COMPUTER SOFTWARE FOR CREATING INDEXES OF INFORMATION, INDEXES OF WEB SITES AND INDEXES OF OTHER INFORMATION RESOURCES; MOUSE PADS.

FIRST USE 11-0-2000; IN COMMERCE 11-0-2000.

INT. CL. 11/U.S. CLS. 13, 21, 23, 31 AND 34

FOR LAMPS.

FIRST USE 6-0-2002; IN COMMERCE 6-0-2002.

INT. CL. 12/U.S. CLS. 19, 21, 23, 31, 35 AND 44

FOR LICENSE PLATE FRAMES AND HOLDERS.

FIRST USE 6-0-2002; IN COMMERCE 6-0-2002.

INT. CL. 16/U.S. CLS. 2, 5, 22, 23, 29, 37, 38 AND 50

FOR NOTEBOOKS, PENS, STICKERS, DECALS.

FIRST USE 6-0-2002; IN COMMERCE 6-0-2002.

INT. CL. 18/U.S. CLS. 1, 2, 3, 22 AND 41

FOR BAGS, NAMELY, TOTE BAGS, DUFFLE BAGS, BACKPACKS; UMBRELLAS.

FIRST USE 6-0-2002; IN COMMERCE 6-0-2002.

INT. CL. 21/U.S. CLS. 2, 13, 23, 29, 30, 33, 40 AND 50

FOR MUGS, TUMBLERS.

FIRST USE 6-0-2002; IN COMMERCE 6-0-2002.

INT. CL. 25/U.S. CLS. 22 AND 39

FOR CLOTHING, NAMELY, SHIRTS, T-SHIRTS, VESTS, HATS, CAPS, BOXER SHORTS; CHILDREN'S CLOTHING, NAMELY, T-SHIRTS.

FIRST USE 1-0-2001; IN COMMERCE 1-0-2001.

INT. CL. 28/U.S. CLS. 22, 23, 38 AND 50

FOR TOYS AND SPORTING EQUIPMENT, NAMELY PLASTIC EXERCISE BALLS.

FIRST USE 1-0-2001; IN COMMERCE 1-0-2001.

INT. CL. 35/U.S. CLS. 100, 101 AND 102

FOR ELECTRONIC RETAILING SERVICES VIA COMPUTER FEATURING MOUSE PADS, LAMPS, LICENSE PLATE FRAMES AND HOLDERS, NOTEBOOKS, PENS, STICKERS, DECALS, TOTE BAGS, DUFFLE BAGS, BACKPACKS, UMBRELLAS, MUGS, TUMBLERS, SHIRTS, T-SHIRTS, MODEM CORDS, TOYS, VESTS, CAPS, HATS, AND OTHER CLOTHING ITEMS.

FIRST USE 7-31-1999; IN COMMERCE 7-31-1999.

INT. CL. 38/U.S. CLS. 100, 101 AND 104

FOR PROVIDING MULTIPLE USER ACCESS TO PROPRIETARY COLLECTIONS OF INFORMATION BY MEANS OF GLOBAL COMPUTER INFORMATION NETWORKS.

FIRST USE 9-0-1997; IN COMMERCE 9-0-1997.

INT. CL. 42/U.S. CLS. 100 AND 101

FOR COMPUTER SERVICES, NAMELY, PROVIDING SOFTWARE INTERFACES AVAILABLE OVER A NETWORK IN ORDER TO CREATE PERSONALIZED ONLINE INFORMATION SERVICES; EXTRACTION AND RETRIEVAL OF INFORMATION AND DATA MINING BY MEANS OF GLOBAL COMPUTER NETWORKS; CREATING INDEXES OF INFORMATION, INDEXES OF WEB SITES AND INDEXES OF OTHER INFORMATION SOURCES IN CONNECTION WITH GLOBAL COMPUTER NETWORK; PROVIDING INFORMATION FROM SEARCHABLE INDEXES AND DATABASES OF INFORMATION, INCLUDING TEXT, ELECTRONIC DOCUMENTS, DATABASES, GRAPHIC AND AUDIO VISUAL INFORMATION, BY MEANS OF GLOBAL COMPUTER INFORMATION NETWORKS.

FIRST USE 9-0-1997; IN COMMERCE 9-0-1997.

ELEMENTS AMENDED
MARK

3,172,072. REG. 11-14-2006. PLAYBOY ENTERPRISES INTERNATIONAL, INC. (DELAWARE CORPORATION) 680 N. LAKE SHORE DRIVE, CHICAGO, IL, 60611, SN 78-377,854. FILED 3-3-2004. PRINCIPAL REGISTER.

PLAYBOY

THE MARK CONSISTS OF STANDARD CHARACTERS WITHOUT CLAIM TO ANY PARTICULAR FONT, STYLE, SIZE, OR COLOR.

INT. CL. 35/U.S. CLS. 100, 101 AND 102

FOR RETAIL STORE SERVICES FEATURING CLOTHING, NOVELTIES, PUBLICATIONS, LINGERIE, JEWELRY, CDS AND VIDEOS, GAMES AND TOYS, PAPER GOODS, HOME ACCESSORIES, SPORTING GOODS, ELECTRONICS, HOUSE WARES, CANDY, CONFECTIONS AND SMOKER'S ARTICLES.

FIRST USE 5-23-2005; IN COMMERCE 5-23-2005.

ELEMENTS CORRECTED
CITIZENSHIP

3,178,188. REG. 11-28-2006. CAESARS WORLD, INC. (FLORIDA CORPORATION) ONE CAESARS PALACE DRIVE, LAS VEGAS, NV, 89109, SN 78-567,836. FILED 2-15-2005. PRINCIPAL REGISTER.

THE PIER SHOPS AT CAESARS

THE MARK CONSISTS OF STANDARD CHARACTERS WITHOUT CLAIM TO ANY PARTICULAR FONT, STYLE, SIZE, OR COLOR.

OWNER OF U.S. REG. NOS. 954,637, 1,001,363 AND OTHERS.

NO CLAIM IS MADE TO THE EXCLUSIVE RIGHT TO USE SHOPS, APART FROM THE MARK AS SHOWN.

INT. CL. 35/U.S. CLS. 100, 101 AND 102

FOR RETAIL STORE SERVICES, FEATURING A VARIETY OF GOODS, NAMELY GENERAL MERCHANDISE, SOUVENIRS, NOVELTY ITEMS, GIFT ITEMS, CLOTHING, CLOTHING ACCESSORIES, JEWELRY, TOYS, SPORTING GOODS, STATIONARY PRODUCTS, BOOKS, VIDEOS, FRAGRANCES, PERSONAL CARE PRODUCTS, COSMETICS, HOUSE WARES, ART, FOODS, BEVERAGES, CIGARETTES AND SMOKING ACCESSORIES.

FIRST USE 6-27-2006; IN COMMERCE 6-27-2006.
INT. CL. 36/U.S. CLS. 100, 101 AND 102
FOR SHOPPING MALL SERVICES, NAMELY, LEASING OF SHOPPING MALL SPACE; LEASING OF SPACE IN SHOPPING MALLS.

FIRST USE 6-27-2006; IN COMMERCE 6-27-2006.
INT. CL. 43/U.S. CLS. 100 AND 101

FOR RESTAURANT SERVICES, NAMELY, FAST FOOD, FAMILY AND FINE DINING, AND FAST FOOD RESTAURANT SERVICES IN WHICH VENDORS SELL FOOD AT STATIONS ABOUT A COMMON EATING SPACE.

FIRST USE 6-27-2006; IN COMMERCE 6-27-2006.

ELEMENTS AMENDED
DISCLAIMER
MARK

3,198,844. REG. 1-16-2007. THE ORIGINAL LITTLE SPROUT, LLC (CALIFORNIA LIMITED LIABILITY COMPANY) 13615 OLD MORRO RD, ATASCADERO, CA, 93422, SN 78-841,738. FILED 3-20-2006. PRINCIPAL REGISTER.

SCRUMPTIOUS BABY CREAM

THE MARK CONSISTS OF STANDARD CHARACTERS WITHOUT CLAIM TO ANY PARTICULAR FONT, STYLE, SIZE, OR COLOR.

NO CLAIM IS MADE TO THE EXCLUSIVE RIGHT TO USE "BABY CREAM", APART FROM THE MARK AS SHOWN.

INT. CL. 3/U.S. CLS. 1, 4, 6, 50, 51 AND 52
FOR NON-MEDICATED FACE AND BODY CREAMS AND LOTIONS FOR BABIES.

FIRST USE 1-0-2003; IN COMMERCE 1-0-2003.

ELEMENTS CORRECTED
OWNER NAME
ENTITY

3,492,931. REG. 8-26-2008. DOMICIL PTE. LTD. (SINGAPORE PRIVATE LIMITED COMPANY) 11 GUL CIRCLE, SINGAPORE 629567, SINGAPORE,, SN 79-044,080. FILED 3-15-2007. PRINCIPAL REGISTER.

DOMICIL

OWNER OF INTERNATIONAL REGISTRATION 0585776 DATED 4-2-1992, EXPIRES 4-2-2012.
OWNER OF U.S. REG. NO. 1,839,964.
INT. CL. 11/U.S. CLS. 13, 21, 23, 31 AND 34

FOR [APPARATUS FOR LIGHTING, NAMELY, BOOK LIGHTS, CANDLE LAMPS, CANDLE LANTERNS, CHANDELIERS, ELECTRIC LANTERNS, ELECTRIC LIGHT BULBS, ELECTRIC LIGHTING FIXTURES, LAMP BASES, LAMP SHADES, LAMPS, LAMP SHADE HOLDERS, LANTERNS].

FIRST USE ; IN COMMERCE .
INT. CL. 24/U.S. CLS. 42 AND 50

FOR TEXTILES AND TEXTILE GOODS, NAMELY, TEXTILE FABRICS FOR USE IN HOME AND COMMERCIAL INTERIORS; CURTAINS; TEXTILE FABRICS FOR THE MANUFACTURE OF BLINDS AND SHADES; HOUSEHOLD LINEN, NAMELY, TABLE LINEN NOT OF PAPER AND BED LINEN, BED BLANKETS AND TABLE CLOTHS NOT OF PAPER.

FIRST USE ; IN COMMERCE .

ELEMENTS CORRECTED
GOODS/SERVICES

3,542,801. REG. 12-9-2008. MAYER, JAMES (UNITED STATES INDIVIDUAL) 8220 S. 20TH STREET, LINCOLN, NE, 68512, SN 77-341,694. FILED 11-30-2007. PRINCIPAL REGISTER.

HIPPY'S BLEEDER CHAIN

THE MARK CONSISTS OF STANDARD CHARACTERS WITHOUT CLAIM TO ANY PARTICULAR FONT, STYLE, SIZE, OR COLOR.

NO CLAIM IS MADE TO THE EXCLUSIVE RIGHT TO USE "CHAIN", APART FROM THE MARK AS SHOWN.

INT. CL. 28/U.S. CLS. 22, 23, 38 AND 50

FOR ARTIFICIAL FISHING BAIT; ARTIFICIAL FISHING LURES; [ARTIFICIAL FISHING WORMS; BITE INDICATORS; BITE SENSORS;] FISH ATTRACTANTS; FISH HOOKS, FISHING FLIES, FISHING FLOATS, FISHING HOOKS; FISHING LURE PARTS; FISHING LURES; [FISHING LURES, NAMELY, LEECHES; FISHING LURES, NAMELY, PLASTIC WORMS; FISHING LURES, NAMELY, SPOONS; FISHING SINKERS;] FISHING SPINNERS; FISHING TACKLE; [FISHING TACKLE, NAMELY, BOBBERS;] FLIES FOR USE IN FISHING; FLOATS FOR FISHING; LURES FOR FISHING; [LURES FOR HUNTING OR FISHING; SCENT LURES FOR HUNTING OR FISHING].

FIRST USE 5-7-2008; IN COMMERCE 8-2-2008.

ELEMENTS CORRECTED
GOODS/SERVICES
DATE OF FIRST USE
DATE OF FIRST USE IN COMMERCE

3,563,058. REG. 1-20-2009. KINETIC JUMP SOFTWARE, LLC (MINNESOTA LIMITED LIABILITY COMPANY) 15165 WOOD DUCK TRAIL, PRIOR LAKE, MN, 55372, SN 77-182,050. FILED 5-16-2007. PRINCIPAL REGISTER.

AppLife

INT. CL. 9/U.S. CLS. 21, 23, 26, 36 AND 38

FOR COMPUTER SOFTWARE DEVELOPMENT TOOLS.
FIRST USE 5-1-2006; IN COMMERCE 5-1-2006.

ELEMENTS CORRECTED
MARK

3,620,807. REG. 5-12-2009. CONDOS, CHRISTOPHER (UNITED STATES INDIVIDUAL) 446 ORCHARD STREET, SANTA ROSA, CA, 95404, SN 77-536,526. FILED 7-31-2008. PRINCIPAL REGISTER.

HORSE AND PLOW

THE MARK CONSISTS OF STANDARD CHARACTERS WITHOUT CLAIM TO ANY PARTICULAR FONT, STYLE, SIZE, OR COLOR.

INT. CL. 33/U.S. CLS. 47 AND 49
FOR WINE.
FIRST USE 2-11-2009; IN COMMERCE 2-11-2009.

ELEMENTS CORRECTED
[DBA/AKA]

FOR PLASTIC PACKAGING MATERIAL, NAMELY, PLASTIC BAGS FOR PACKAGING, PLASTIC BUBBLE PACKS FOR WRAPPING OR PACKAGING; CARDBOARD CARTONS FOR PACKAGING; PACKAGING MATERIAL OF PAPER, NAMELY, PACKAGING PAPER, PAPER BAGS FOR PACKAGING; PACKAGING FILM OF PLASTIC NOT FOR COMMERCIAL OR INDUSTRIAL PURPOSES, USED TO WRAP FOOD FOR HOUSEHOLD USE; STRETCH FILM OF PLASTIC FOR PACKAGING NOT FOR COMMERCIAL OR INDUSTRIAL PURPOSES, USED TO WRAP FOOD FOR HOUSEHOLD USE.

FIRST USE ; IN COMMERCE .

INT. CL. 20/U.S. CLS. 2, 13, 22, 25, 32 AND 50

FOR AIRBAGS AND AIR CUSHIONS NOT FOR MEDICAL APPLICATIONS FOR SAFEGUARDING OF GOODS AND WARES.

FIRST USE ; IN COMMERCE .

INT. CL. 22/U.S. CLS. 1, 2, 7, 19, 22, 42 AND 50

FOR BELTS, NOT MADE OF METAL, FOR CLAMPING AND HANDLING LOADS; ROPES; STRETCHING BELTS, NOT MADE OF METAL, FOR HANDLING LOADS; TEXTILE PACKAGING MATERIAL, NAMELY, INDUSTRIAL PACKAGING CONTAINERS OF TEXTILE; PACKAGING BAGS OF TEXTILE MATERIAL; LASHING MATERIALS, NAMELY, BELTS, NOT MADE OF METAL FOR CLAMPING AND STRAPS FOR ANGULAR CLAMPING OF LOADS, GOODS AND WARES.

FIRST USE ; IN COMMERCE .

3,746,874. REG. 2-9-2010. RAINER GMBH (FED REP GERMANY LIMITED LIABILITY COMPANY) FRANKFURTER STRAÙE 493, 51145 KÖLN, FED REP GERMANY., SN 79-032,565. FILED 6-19-2006. PRINCIPAL REGISTER.



PRIORITY DATE OF 12-19-2005 IS CLAIMED.
OWNER OF INTERNATIONAL REGISTRATION 0907700 DATED 6-19-2006. EXPIRES 6-19-2016.

THE COLOR(S) RED, GRAY AND WHITE IS/ARE CLAIMED AS A FEATURE OF THE MARK.

THE MARK CONSISTS OF A FILLED-IN CIRCLE, WHICH IS SURROUNDED BY A SEMI-CIRCLE THAT DOES NOT MEET IN THE TOP OR BOTTOM MIDDLE OF THE SEMI-CIRCLE. THE COLOR RED REPRESENTS THE FILLED-IN MIDDLE CIRCLE, WHICH IS SURROUNDED BY A GRAY SEMI-CIRCLE THAT DOES NOT MEET IN THE TOP OR BOTTOM MIDDLE OF THE SEMI-CIRCLE AND A WHITE BACKGROUND.

INT. CL. 16/U.S. CLS. 2, 5, 22, 23, 29, 37, 38 AND 50

INT. CL. 39/U.S. CLS. 100 AND 105

FOR TRANSPORT OF GOODS, NAMELY, CONTAINER TRANSPORT; PACKAGING ARTICLES FOR TRANSPORTATION, NAMELY, RESTRAINING OF CARGO DURING TRANSPORTATION; PACKAGING ARTICLES FOR TRANSPORTATION, NAMELY, RESTRAINING OF WARES AND GOODS IN CONNECTION WITH LOADING SERVICES DURING TRANSPORTATION; PACKAGING OF WARES AND GOODS, NAMELY, FLUIDS AND SOLIDS NOT FOR MEDICAL APPLICATIONS; PACKAGING OF ARTICLES FOR TRANSPORTATION, NAMELY, PACKAGING, BAGS, BARRELS, CASKS, BINS, BOXES AND CARTONS USED FOR RESTRAINING OF WARES AND GOODS DURING TRANSPORTATION NOT FOR MEDICAL APPLICATIONS. [* ALL OF THE AFOREMENTIONED SERVICES NOT IN CONNECTION WITH THE REMOVAL AND STORAGE OF WASTE MATERIALS OCCURRING PARTICULARLY AT THE CLEANING OF BUILDINGS, EQUIPMENT, MACHINES AND TEXTILES, AT THE REMEDIATION OF FIRE AND WATER DAMAGE, AT DEMOLITION WORK, PLUMBING WORK AND REPAIRS OF BUILDINGS, AT THE DEHUMIDIFICATION OF BUILDINGS AND REMEDIATION OF DAMAGE CAUSED BY FIRE, SMOKE, WATER FOR FIREFIGHTING, TAP WATER AND FLOODING *]

* ALL THE AFORESAID SERVICES NOT IN CONNECTION WITH THE TRANSPORT AND STORAGE ESPECIALLY OF USED MATERIALS ACCUMULATED FROM THE CLEANING OF BUILDINGS, INSTALLATIONS, MACHINES AND TEXTILES, AS WELL AS FROM THE SANITATION OF WATER AND FIRE DAMAGES, FROM DEMOLITION WORKS, PLUMBING AND REPAIR OF BUILDINGS, FROM THE DEHUMIDIFICATION OF BUILDINGS AND ALSO FROM MEASURES OF SANITATION FOR DAMAGES THROUGH FIRE, SMOKE, WATER FOR FIRE-FIGHTING, TAP WATER AND FLOODS *

FIRST USE ; IN COMMERCE .

ELEMENTS CORRECTED
GOODS/SERVICES

3,817,093. REG. 7-13-2010. MEDPRO SYSTEMS, LLC (NEW JERSEY LIMITED LIABILITY COMPANY) 100 STIERLI COURT - SUITE 100, MT. ARLINGTON, NJ, 07856, SN 77-854,834. FILED 10-22-2009. PRINCIPAL REGISTER.

3,934,862. REG. 3-22-2011. E.K. SUCCESS, LTD. (NEW YORK CORPORATION) 100 DELAWANNA AVENUE, CLIFTON, NJ, 07014, SN 77-607,483. FILED 11-5-2008. PRINCIPAL REGISTER.



EKSUCCESS BRANDS

OWNER OF U.S. REG. NOS. 386,303, 3,813,521 AND OTHERS.

NO CLAIM IS MADE TO THE EXCLUSIVE RIGHT TO USE ".COM", APART FROM THE MARK AS SHOWN.

THE COLOR(S) WHITE, GRAY AND BLUE IS/ARE CLAIMED AS A FEATURE OF THE MARK.

THE MARK CONSISTS OF THE IMAGE OF A CAPSULE WITH A GRAY BORDER, THE LEFT SIDE OF WHICH IS WHITE ON THE INSIDE, THE RIGHT SIDE OF WHICH IS GRAY ON THE INSIDE, AND ON WHICH THE WORDS "POWERED BY MEDPROID.COM" ARE IN BLUE LETTERS ON THE INSIDE.

INT. CL. 35/U.S. CLS. 100, 101 AND 102

FOR ELECTRONIC MATCHING SERVICES COMBINING PROPRIETARY ALGORITHMS AND OTHER MATHEMATICAL OPERATIONS WITH A DATABASE CONTAINING LICENSING INFORMATION ABOUT HEALTHCARE PROFESSIONALS FOR THE PURPOSE OF DETERMINING THE ELIGIBILITY OF HEALTHCARE PRACTITIONERS IDENTIFIED BY CUSTOMERS TO RECEIVE PHARMACEUTICAL PRODUCTS.

FIRST USE 6-11-2005; IN COMMERCE 6-11-2005.

THE MARK CONSISTS OF STANDARD CHARACTERS WITHOUT CLAIM TO ANY PARTICULAR FONT, STYLE, SIZE, OR COLOR.

OWNER OF U.S. REG. NOS. 3,396,017, 3,529,988 AND OTHERS.

NO CLAIM IS MADE TO THE EXCLUSIVE RIGHT TO USE "BRANDS", APART FROM THE MARK AS SHOWN.

INT. CL. 8/U.S. CLS. 23, 28 AND 44

FOR ENGRAVING NEEDLES; HAND TOOLS, NAMELY, ENGRAVERS; HAND TOOLS, NAMELY, PUNCHES; SCISSORS.

FIRST USE 9-1-2009; IN COMMERCE 9-1-2009.

INT. CL. 14/U.S. CLS. 2, 27, 28 AND 50

FOR JEWELRY.

FIRST USE 4-15-2009; IN COMMERCE 4-15-2009.

INT. CL. 16/U.S. CLS. 2, 5, 22, 23, 29, 37, 38 AND 50

FOR PRINTED INVITATIONS; STICKERS.

FIRST USE 9-1-2009; IN COMMERCE 9-1-2009.

INT. CL. 20/U.S. CLS. 2, 13, 22, 25, 32 AND 50

FOR PICTURE AND PHOTOGRAPH FRAMES.

FIRST USE 9-1-2009; IN COMMERCE 9-1-2009.

INT. CL. 26/U.S. CLS. 37, 39, 40, 42 AND 50

FOR BEADS FOR HANDICRAFT WORK; BEADS OTHER THAN FOR MAKING JEWELRY; NEEDLE-POINT KITS, CONSISTING OF YARN, CANVAS OR FABRIC, NEEDLE AND INSTRUCTIONS; NEEDLES; RIBBONS.

FIRST USE 9-1-2009; IN COMMERCE 9-1-2009.

INT. CL. 41/U.S. CLS. 100, 101 AND 107

FOR EDUCATIONAL SERVICES IN THE NATURE OF CONDUCTING PROGRAMS IN THE FIELD OF SCRAPBOOK DESIGN AND DISTRIBUTING COURSE MATERIALS IN CONNECTION THEREWITH; TRANSIENT TRAINING PROGRAMS THAT INSTRUCT OTHERS ON HOW TO CREATE SPECIFIC LETTERING AND DECORATING COMPOSITIONS THAT CAN BE EMPLOYED IN SCRAPBOOKS OR OTHER MEDIUMS.

FIRST USE 2-1-2009; IN COMMERCE 2-1-2009.

ELEMENTS AMENDED
PRIOR U.S. REGS.

ELEMENTS CORRECTED
ENTITY

3,924,472. REG. 3-1-2011. HUBCO AUTOMOTIVE LTD. (NEW ZEALAND LIMITED LIABILITY COMPANY) DLA PHILIPS FOX, 209 QUEEN STREET, AUCKLAND, NEW ZEALAND, 9154, SN 77-678,240. FILED 2-25-2009. PRINCIPAL REGISTER.



SPIER

OWNER OF NEW ZEALAND REG. NO. 781570, DATED 12-18-2007, EXPIRES 12-18-2017.

NO CLAIM IS MADE TO THE EXCLUSIVE RIGHT TO USE "TECHNOLOGY", APART FROM THE MARK AS SHOWN.

THE MARK CONSISTS OF "WHISPBAR" IN STYLIZED LETTERING AND THE WORD "TECHNOLOGY" PLACED BELOW "BAR" IN "WHISPBAR".

INT. CL. 12/U.S. CLS. 19, 21, 23, 31, 35 AND 44

FOR ROOF RACKS AND LUGGAGE CARRIERS FOR MOTOR VEHICLES CONSISTING OF NETS, BOXES, CONTAINERS, RESTRAINTS AND FASTENINGS USED FOR CARRYING BICYCLES, CANOES, LUGGAGE, SKIS, EQUIPMENT, TOOLS AND MERCHANDISE; PARTS, FITTINGS AND COMPONENTS PARTS FOR THE ROOF RACKS AND LUGGAGE CARRIERS.

3,957,116. REG. 5-10-2011. SPIER WINES (PROPRIETARY) LIMITED (SOUTH AFRICA CORPORATION) ANNANDALE ROAD, STELLENBOSCH 7600, SOUTH AFRICA., SN 85-093,958. FILED 7-27-2010. PRINCIPAL REGISTER.

THE MARK CONSISTS OF STANDARD CHARACTERS WITHOUT CLAIM TO ANY PARTICULAR FONT, STYLE, SIZE, OR COLOR.

OWNER OF SOUTH AFRICA REG. NO. 97/07791, DATED 5-26-1997, EXPIRES 5-26-2017.

OWNER OF U.S. REG. NOS. 2,745,465, 2,864,123 AND 3,641,543.

INT. CL. 33/U.S. CLS. 47 AND 49

ELEMENTS CORRECTED
OWNER NAME
OWNER ADDRESS

FOR WINE.
FIRST USE 0-0-1712; IN COMMERCE 1-0-2002.

ELEMENTS CORRECTED
GOODS/SERVICES

3,976,524. REG. 6-14-2011. MMH PTY LTD (AUSTRALIA PROPRIETARY COMPANY (PTY.)) LEVEL 2, 141 FLINDERS LANE; MELBOURNE VIC 3000, AUSTRALIA., SN 79-050,812. FILED 11-30-2007. PRINCIPAL REGISTER.



PRIORITY DATE OF 10-16-2007 IS CLAIMED.
OWNER OF INTERNATIONAL REGISTRATION 0955907 DATED 11-30-2007, EXPIRES 11-30-2017.

INT. CL. 9/U.S. CLS. 21, 23, 26, 36 AND 38
FOR LAPTOP COMPUTER BAGS; CARRYING CASES FOR CABLES; * COMPUTER CARRYING CASES; * CARRIERS AND BAGS FOR STORING AND CARRYING COMPACT DISCS, DVD'S, COMPUTERS AND AUDIO- VISUAL APPARATUS; CASES FOR PHOTOGRAPHIC APPARATUS.
FIRST USE ; IN COMMERCE .

ELEMENTS CORRECTED
GOODS/SERVICES

3,989,407. REG. 7-5-2011. UNIVERSITY OF NORTH CAROLINA AT CHAPEL HILL (NORTH CAROLINA (STATE UNIVERSITY, NORTH CAROLINA)) 308 BYNUM HALL CAMPUS, BOX 4105, CHAPEL HILL, NC, 27599, SN 85-173,286. FILED 11-10-2010. PRINCIPAL REGISTER.

INNOVATE @ CAROLINA

THE MARK CONSISTS OF STANDARD CHARACTERS WITHOUT CLAIM TO ANY PARTICULAR FONT, STYLE, SIZE, OR COLOR.

INT. CL. 41/U.S. CLS. 100, 101 AND 107
FOR EDUCATIONAL SERVICES, NAMELY, CONDUCTING PROGRAMS FOR THE PROMOTION OF INNOVATION ON CAMPUS .
FIRST USE 10-5-2010; IN COMMERCE 10-5-2010.

ELEMENTS CORRECTED
ENTITY

3,989,408. REG. 7-5-2011. UNIVERSITY OF NORTH CAROLINA AT CHAPEL HILL (NORTH CAROLINA (STATE UNIVERSITY, NORTH CAROLINA)) 308 BYNUM HALL CAMPUS, BOX 4105, CHAPEL HILL, NC, 27599, SN 85-173,307. FILED 11-10-2010. PRINCIPAL REGISTER.



THE MARK CONSISTS OF AT SYMBOL, "@", FORMING A LIGHT BULB WITH FIVE MARKS ABOVE THE CIRCLE MAKING THE GLOW OF THE BULB.

INT. CL. 41/U.S. CLS. 100, 101 AND 107

FOR EDUCATIONAL SERVICES, NAMELY, CONDUCTING PROGRAMS FOR THE PROMOTION OF INNOVATION ON CAMPUS.

FIRST USE 10-5-2010; IN COMMERCE 10-5-2010.

ELEMENTS CORRECTED
ENTITY

3,994,836. REG. 7-12-2011. UNIVERSITY OF NORTH CAROLINA AT CHAPEL HILL (NORTH CAROLINA (STATE UNIVERSITY, NORTH CAROLINA)) 308 BYNUM HALL CAMPUS, BOX 4105, CHAPEL HILL, NC, 27599, SN 85-011,621. FILED 4-12-2010. PRINCIPAL REGISTER.

MINDS ON A MISSION

THE MARK CONSISTS OF STANDARD CHARACTERS WITHOUT CLAIM TO ANY PARTICULAR FONT, STYLE, SIZE, OR COLOR.

INT. CL. 41/U.S. CLS. 100, 101 AND 107

FOR EDUCATION SERVICES IN THE NATURE OF COURSES AT THE UNIVERSITY LEVEL.

FIRST USE 2-4-2010; IN COMMERCE 2-4-2010.

ELEMENTS CORRECTED
ENTITY

4,000,559. REG. 7-26-2011. ASECA AG (SWITZERLAND AG) ZÜGERSTRASSE 46, CH-6314 UNTERÄGERI, SWITZERLAND., SN 79-085,857. FILED 4-6-2010. PRINCIPAL REGISTER.

Aseca

THE MARK CONSISTS OF STANDARD CHARACTERS WITHOUT CLAIM TO ANY PARTICULAR FONT, STYLE, SIZE, OR COLOR.

PRIORITY DATE OF 3-11-2010 IS CLAIMED.
OWNER OF INTERNATIONAL REGISTRATION 1047053 DATED 4-6-2010, EXPIRES 4-6-2020.

THE WORDING "ASECA" HAS NO MEANING IN A FOREIGN LANGUAGE.

INT. CL. 1/U.S. CLS. 1

FOR WATER-BASED CHEMICALS USED IN INDUSTRY, SCIENCE AND PHOTOGRAPHY; WATER-BASED CHEMICALS USED IN AGRICULTURE, HORTICULTURE AND FORESTRY EXCEPT FUNGICIDES, HERBICIDES, INSECTICIDES AND PARASITICIDES; OENOLOGICAL BACTERICIDES; BACTERIOLOGICAL PREPARATIONS, NAMELY, BACTERIA FOR WATER TREATMENT, BACTERIA FOR WASTE WATER TREATMENT, BACTERIA FOR USE IN FOOD MANUFACTURE, BACTERIAL ADDITIVE FOR BREAKDOWN OF ANIMAL WASTE; CHEMICAL SUBSTANCES FOR PRESERVING GOODS AND FOODSTUFFS, NAMELY, FOOD PRESERVING CHEMICALS, CHEMICAL PRESERVATIVES FOR USE IN THE PRODUCTION OF A WIDE VARIETY OF CHEMICALS, CHEMICAL PRESERVATIVES FOR USE AS CORROSION INHIBITORS ON AUTOMOBILE EXHAUST SYSTEMS; ALLYL CHLORIDE, ALUMINIUM CHLORIDE, AMMONIUM CHLORIDE, BARIUM CHLORIDE, BENZYL CHLORIDE, BISMUTH CHLORIDE, CACODYL CHLORIDE, CALCIUM CHLORIDE, CALOMEL (MERCUROUS CHLORIDE), CERIUM CHLORIDE, CHROMIUM CHLORIDE, ETHYL CHLORIDE, GOLD CHLORIDE, HYDROCHLORIC ACID (HYDROGEN CHLORIDE), IRON CHLORIDE, MAGNESIUM CHLORIDE, MANGANESE CHLORIDE, MERCURIC CHLORIDE, METAL CHLORIDES, METHYL CHLORIDE, METHYLENE CHLORIDE, PALADIUM CHLORIDE, PHOSPHORUS CHLORIDE, SILVER CHLORIDE, SODIUM CHLORIDE, SODIUM GOLD CHLORIDE, TIN CHLORIDE, TOLUENESULFONYL CHLORIDE, VINYL CHLORIDE, VINYLIDENE CHLORIDE, ZINC CHLORIDE, ZIRCONIUM CHLORIDE; CHLORINE; SODIUM CHLORATES; HYDROCHLORATES.

FIRST USE ; IN COMMERCE .

INT. CL. 3/U.S. CLS. 1, 4, 6, 50, 51 AND 52

FOR BLEACHING PREPARATIONS FOR COSMETIC PURPOSES; BLEACHING PREPARATIONS FOR HOUSEHOLD USE; BLEACHING PREPARATIONS FOR LAUNDRY USE; COSMETICS; CLEANING, POLISHING, SCOURING AND ABRASIVE PREPARATIONS; SOAPS; PERFUMERY; ESSENTIAL OILS; HAIR LOTIONS; DENTIFRICES.

FIRST USE ; IN COMMERCE .

INT. CL. 5/U.S. CLS. 6, 18, 44, 46, 51 AND 52

FOR PHARMACEUTICAL PREPARATIONS FOR THE TREATMENT AND PREVENTION OF INFECTIOUS DISEASES, EYE DISEASES AND CONDITIONS, DISORDERS OF THE NERVOUS SYSTEM, THE IMMUNE SYSTEM, THE CARDIOVASCULAR SYSTEM, THE METABOLIC SYSTEM, THE RESPIRATORY SYSTEM, THE MUSCULOSKELETAL SYSTEM, THE GENITOURINARY SYSTEM, FOR THE TREATMENT OF INFLAMMATORY DISORDERS, FOR USE IN DERMATOLOGY, ONCOLOGY, HEMATOLOGY AND IN TISSUE AND ORGAN TRANSPLANTATION, IN OPHTHALMOLOGY AND FOR GASTROENTEROLOGICAL DISORDERS; PHARMACEUTICAL PREPARATIONS FOR THE TREATMENT AND PREVENTION OF OCULAR DISORDERS OR DISEASES, FOR THE TREATMENT OF BACTERIA-BASED DISEASES, AND FOR THE TREATMENT OF DIABETES, AND ANTI-INFECTIVE PREPARATIONS, ANTIVIRAL PREPARATIONS, ANTIBIOTICS, ANTIFUNGAL PREPARATIONS AND VACCINES; PHARMACEUTICAL AND VETERINARY PREPARATIONS FOR THE TREATMENT AND PREVENTION OF VIRAL, METABOLIC, ENDOCRINE, MUSCULOSKELETAL, CARDIOVASCULAR, CARDIOPULMONARY, GENITOURINARY, ONCOLOGICAL, HEPATOLOGICAL, OPHTHALMIC, RESPIRATORY, NEUROLOGICAL, GASTROINTESTINAL, HORMONAL, DERMATOLOGICAL, PSYCHIATRIC AND IMMUNE SYSTEM RELATED DISEASES AND DISORDERS; BACTERICIDES; CHEMICAL PREPARATIONS FOR PHARMACEUTICAL PURPOSES, NAMELY, BETA BLOCKERS, ASTRINGENTS, ANTIBIOTICS, PENICILLIN; CHEMICAL PREPARATIONS FOR MEDICAL PURPOSES, NAMELY, ANTI-BACTERIAL SUBSTANCES FOR MEDICAL PURPOSES, BACTERIAL AND BACTERIOLOGICAL PREPARATIONS FOR MEDICAL PURPOSES, DIAGNOSTIC PREPARATIONS FOR MEDICAL PURPOSES; SANITARY PREPARATIONS FOR MEDICAL PURPOSES; DISINFECTANTS FOR SANITARY PURPOSES, DISINFECTANTS FOR MEDICAL INSTRUMENTS, DISINFECTANTS FOR HYGIENIC PURPOSES; [FUNGICIDES; GERMICIDES;] MEDICAL PREPARATIONS,

NAMELY, DIAGNOSTIC PREPARATIONS FOR MEDICAL PURPOSES, SANITARY PREPARATIONS FOR MEDICAL PURPOSES; BACTERIOLOGICAL PREPARATIONS FOR MEDICAL AND VETERINARY PURPOSES; BALMS FOR MEDICAL PURPOSES; BIOLOGICAL PREPARATIONS FOR MEDICAL PURPOSES, NAMELY, ANTIBACTERIAL SUBSTANCES FOR MEDICAL PURPOSES, BACTERIAL AND BACTERIOLOGICAL PREPARATIONS FOR MEDICAL PURPOSES, DIAGNOSTIC PREPARATIONS FOR MEDICAL PURPOSES; FERMENTS FOR PHARMACEUTICAL PURPOSES; DIETETIC SUBSTANCES ADAPTED FOR MEDICAL USE, NAMELY, DIETETIC BEVERAGES ADAPTED FOR MEDICAL PURPOSES, DIETETIC FOODS ADAPTED FOR MEDICAL USE, DIETETIC FOODS ADAPTED FOR MEDICAL PURPOSES, DIETETIC SUGAR FOR MEDICAL USE, DIETETIC SUGAR SUBSTITUTES FOR MEDICAL USE; FOOD FOR BABIES; MEDICAL AND SURGICAL PLASTERS; MATERIALS FOR DRESSINGS, NAMELY, BURN DRESSINGS, MEDICAL AND SURGICAL DRESSINGS, SELF-ADHESIVE DRESSINGS, WOUND DRESSINGS; * FUNGICIDES; GERMICIDES; * PREPARATIONS FOR DESTROYING VERMIN; HERBICIDES * ONLY BEING COMPONENTS IN CONNECTION WITH DISINFECTING AND FUMIGATION *; CHEMICALS AND CHEMICAL SUBSTANCES FOR PHARMACEUTICAL PURPOSES, NAMELY, BETA BLOCKERS, ASTRINGENTS, ANTIBIOTICS, PENICILLIN.

FIRST USE ; IN COMMERCE .

INT. CL. 7/U.S. CLS. 13, 19, 21, 23, 31, 34 AND 35

FOR MACHINES FOR THE MANUFACTURE OF DISINFECTANTS; MACHINES FOR THE CHEMICAL INDUSTRY, NAMELY, CALCINING MACHINES FOR CHEMICAL PROCESSING, CHEMICAL FIBER DRYING MACHINES, INDUSTRIAL CHEMICAL REACTORS; MACHINES FOR THE MANUFACTURE OF MEDICAL SUBSTANCES; MACHINES FOR THE MANUFACTURE OF BACTERICIDES IN VARIOUS MEDICAL DELIVERY FORMS; MACHINES FOR AGRICULTURAL PURPOSES, NAMELY, CULTIVATORS, CULTIPACKERS, HARVESTORS, DISK HARROWS, SEEDERS, COMBINES, THRESHERS, TILLERS, WINDROWERS, BALERS FOR AGRICULTURAL USE, REAPERS, AGRICULTURAL SEED PLANTING MACHINES; MACHINES FOR THE DRINKS INDUSTRY AND ALL PARTS AND SPARE PARTS FOR THE AFORESAID GOODS, NAMELY, AERATED BEVERAGE MAKING MACHINES, JUICE MACHINES, PUMPS FOR THE BEVERAGE INDUSTRY, REPLACEMENT PARTS FOR THE AFORESAID GOODS, BRUSHES BEING PARTS OF MACHINES, BEARINGS AS PARTS OF MACHINES.

FIRST USE ; IN COMMERCE .

INT. CL. 11/U.S. CLS. 13, 21, 23, 31 AND 34

FOR MACHINES AND APPARATUS FOR WATER TREATMENT, NAMELY, WATER FILTRATION UNITS, REVERSE OSMOSIS UNITS, WATER FILTERING APPARATUS, WATER CONDITIONING UNITS, WATER PURIFICATION, SEDIMENTATION AND FILTRATION APPARATUS FOR CLARIFICATION, THICKENING AND FILTRATION OF WATER, WASTE WATER AND INDUSTRIAL WATER; DISINFECTANT APPARATUS, NAMELY, DISH DISINFECTANT APPARATUS FOR INDUSTRIAL PURPOSES, DISINFECTANT DISPENSERS FOR TOILETS; HEATING APPARATUS FOR SOLID, LIQUID OR GASEOUS FUELS, NAMELY, GAS WATER HEATERS, HEATING INSTALLATIONS, WATER HEATERS; APPARATUS FOR HEATING, STEAM GENERATING, COOKING, REFRIGERATING, DRYING, VENTILATING, WATER SUPPLY AND SANITARY PURPOSES, NAMELY, HEAT GENERATORS, REFRIGERATORS, GAS STOVES.

FIRST USE ; IN COMMERCE .

INT. CL. 32/U.S. CLS. 45, 46 AND 48

FOR ESSENCES FOR MAKING NON-ALCOHOLIC BEVERAGES; PREPARATIONS FOR MAKING BEVERAGES, NAMELY, FRUIT BEVERAGES, FRUIT-BASED BEVERAGES, FRUIT-FLAVOURED BEVERAGES, ISOTONIC BEVERAGES, VEGETABLE JUICES, SYRUP SUBSTITUTES, WATER BEVERAGES; BEERS, MINERAL AND AERATED WATERS AND OTHER NON-ALCOHOLIC DRINKS, NAMELY, LEMONADE, SODA POPS, PUNCH; FRUIT DRINKS AND FRUIT JUICES.

FIRST USE ; IN COMMERCE .

INT. CL. 40/U.S. CLS. 100, 103 AND 106
FOR WATER TREATMENT.

INT. CL. 44/U.S. CLS. 100 AND 101

FOR PHARMACY SERVICES, NAMELY, DISPENSING OF PHARMACEUTICALS, PHARMACEUTICAL ADVICE, PHARMACISTS' SERVICES TO MAKE UP PRESCRIPTIONS; MEDICAL LABORATORY SERVICES; HEALTH CONSULTANCY; HYGIENIC AND BEAUTY CARE; MEDICAL SERVICES; VETERINARY SERVICES; AGRICULTURE, HORTICULTURE AND FORESTRY SERVICES, NAMELY, VERMIN EXTERMINATING, FOREST HABITAT RESTORATION, AGRICULTURAL ADVICE, HORTICULTURAL SERVICES.
FIRST USE ; IN COMMERCE .

ELEMENTS CORRECTED
GOODS/SERVICES

4,014,452. REG. 8-23-2011. SCHENCK PROCESS GMBH (FED REP GERMANY JOINT STOCK COMPANY) PAL-LASWIENSTRASSE 100, 64293 DARMSTADT, FED REP GERMANY,, AND CARL SCHENCK AG (FED REP GERMANY JOINT STOCK COMPANY) LAND-WEHRSTRASSE 55, 64293 DARMSTADT, FED REP GERMANY,, SN 79-062,323. FILED 12-18-2007. PRINCIPAL REGISTER.



PRIORITY DATE OF 6-18-2007 IS CLAIMED.
OWNER OF INTERNATIONAL REGISTRATION 0985487A DATED 12-18-2007, EXPIRES 12-18-2017.
OWNER OF U.S. REG. NOS. 652,998, 1,151,453 AND OTHERS.

THE COLOR(S) GREY AND BLUE IS/ARE CLAIMED AS A FEATURE OF THE MARK.

THE MARK CONSISTS OF THE WORD "SCHENCKACCURATE" AND TO THE RIGHT OF THE WORDING IS THE IMAGE OF A HIGHLY STYLIZED DESIGN OF THE LETTERS "CSD". THE WORDING APPEARS IN GREY AND THE DESIGN APPEARS IN BLUE.

INT. CL. 6/U.S. CLS. 2, 12, 13, 14, 23, 25 AND 50

FOR TANKS OF METAL OR MAINLY OF METAL, NAMELY, METAL CONTAINERS FOR STORAGE AND TRANSPORTATION OF BULK GOODS.

FIRST USE ; IN COMMERCE .

INT. CL. 7/U.S. CLS. 13, 19, 21, 23, 31, 34 AND 35

FOR MACHINES FOR THE CHEMICAL AND PHARMACEUTICAL INDUSTRY, FOOD INDUSTRY, PLASTICS, PULP AND PAPER INDUSTRY, HEAVY INDUSTRY AND ENVIRONMENTAL INDUSTRY, NAMELY, MACHINES FOR SEPARATING, SORTING FORWARDING, PRESSING AND GRINDING WASTE; ENGINES NOT FOR USE WITH LAND VEHICLES; COUPLINGS AND CLUTCHES FOR POWER TRANSMISSION FOR MACHINES, EXCEPT THOSE MEANT FOR LAND VEHICLES; CONVEYORS, MACHINES WITH MECHANICAL CARRYING DEVICES FOR HOLDING AND EMPTYING OF BULK MATERIAL CONTAINERS, PRINCIPALLY MACHINE EQUIPMENT AS MACHINE PARTS FOR STIRRING AND PASSING ON OF BULK MATERIAL FROM BULK MATERIAL CONTAINERS; MACHINES IN THE NATURE OF VOLUME CONVEYORS; MECHANICAL BULK MATERIAL MIXERS, BOTTLE FILLING MACHINES, MACHINES FOR CLASSIFYING OF BULK MATERIAL IN THE NATURE OF SORTING MACHINES; DRAINAGE SIEVES AS MACHINES OR MACHINE PARTS; CAST IRON UNPACKING MACHINES; MECHANICAL VIBRATION APPARATUS FOR CONVEYING, SHAKING, FEEDING, SCREENING, COMPACTING AND SORTING OF MATERIALS; VIBRATING CONVEYOR CHANNELS AND VIBRATING SIEVES AS MACHINES OR MACHINE PARTS, BASE COMPACTING MACHINES FOR COMPACTING WASTE, PARTS OF VIBRATING MACHINES, IN PARTICULAR DIRECTIONAL EXCITERS, CIRCLE EXCITERS, UNBALANCE MOTORS, MAGNETIC EXCITERS; SPRINGS AS COMPONENT PARTS OF MACHINES AND CARDAN SHAFTS AS MACHINE PARTS; MACHINE OPERATED TRANSPORTATION APPARATUS IN THE NATURE OF CONVEYORS, CONVEYOR

BELTS, CONVEYOR MATS AND PNEUMATIC TRANSPORTERS; SCREW CONVEYORS AND FEEDING SCREW CONVEYORS AS MACHINES OR MACHINE PARTS, CONVEYOR BELTS, CELL SLICES AS MACHINES FOR CONVEYING AND MEASURING OF BULK MATERIAL, CHAIN CONVEYORS, SHEET BANDS, NAMELY, BELTS FOR MACHINES AND CONVEYOR BELTS AS MACHINE PARTS, LIFTING JACKS, NAMELY, POWER OPERATED MECHANICAL EQUIPMENT FOR LIFTING AND LOWERING OF LOADS, BUCKET CONVEYORS, ELEVATORS, BELT CONVEYORS, PATERNOSTER BELTS AS MECHANICAL COMPONENTS, APRON CONVEYORS, MACHINE OPERATED WAGON LOADING AND WAGON UNLOADING APPARATUS, MECHANICAL CONVEYORS FOR PITS, MACHINES FOR CLEANING COAL AND PARTS BELONGING THERETO, IN PARTICULAR CRUSHERS; CHUTES AS COMPONENT PARTS OF SORTING MACHINES, ELECTRIC PUMPS, CONVEYORS, CYCLONES AND SPIRAL SEPARATORS, HYDROCYCLONES, SPIRAL CONCENTRATORS, MAGNETIC SEPARATORS, CENTRIFUGES, DRAINAGE MACHINES IN THE NATURE OF SCREEN SEPARATORS FOR THE DRAINAGE OF ORE, COAL, COKE, SINTER, * PELLETS * [PELLATS] OR ROCK; MECHANICAL EQUIPMENT FOR ADDING OF FLAKE SUBSTANCES IN THE NATURE OF AUTOMATED DISPENSING MACHINES FOR ADDING AND MIXING FLAKED SUBSTANCES FOR INDUSTRIAL PURPOSES.

FIRST USE ; IN COMMERCE .

INT. CL. 9/U.S. CLS. 21, 23, 26, 36 AND 38

FOR PHYSICAL, OPTICAL, ELECTROTECHNICAL AND ELECTRONIC DEVICES FOR CONTROL SYSTEMS AND SURVEILLANCE OF MACHINES, NAMELY, ELECTRONIC CIRCUITS, INSTRUMENTS FOR DETECTING AND MEASURING TWO-DIMENSIONAL DISTRIBUTION OF FORCE AND PRESSURE, MICROSENSORS FOR MEASUREMENT OF PRESSURE, ACCELERATION, FORCE AND FLOW; WEIGHING, MEASURING, SIGNALING AND CONTROLLING APPARATUS AND INSTRUMENTS, NAMELY, SCALES AND BALANCES, LEVEL SWITCHES AND LEVEL INDICATORS FOR MONITORING AND CONTROLLING LIQUIDS IN TANKS AND VESSELS, ENVIRONMENTAL MONITORING SYSTEMS COMPRISED OF METERS AND SENSORS THAT MEASURE PRESSURE, HUMIDITY, TEMPERATURE AND INCLUDES ALARM AND REPORTING FUNCTIONS, FORCE MEASUREMENT PRODUCTS, NAMELY, DIGITAL FORCE GAUGES, DIGITAL TORQUE GAUGES AND MANUAL AND MOTORIZED TEST STANDS USED THERewith SOLD AS A UNIT WITH THE GAUGES; DATA PROCESSORS; COMPUTERS; DEVICES MEANT FOR OSCILLATION MEASUREMENT OR MONITORING OF OSCILLATIONS, NAMELY, TRANSDUCERS THAT UTILIZE ULTRASONIC OSCILLATIONS TO TEST FOR STRESS AND FATIGUE IN METAL; ELECTRO ACOUSTIC TRANSDUCERS FOR MEASURING PURPOSES; ELECTRIC SENSORS FOR MEASURING DENSITY OF DRY BULK GOODS; MEASURING DEVICES, NAMELY, ELECTROACOUSTIC PRESSURE TRANSDUCERS; WEIGHING SCALES; WEIGHING EQUIPMENT, NAMELY, SCALES AND BALANCES; MASS FLOW MEASURING APPARATUS; VEHICLE WEIGHING EQUIPMENT, NAMELY, WEIGHING SCALES; MACHINES FOR MEASURING AND TESTING OF FORCE TRANSDUCERS; WEIGHING MACHINES FOR INDUSTRIAL USE, NAMELY, BELT WEIGHERS, DOSING BELT WEIGHERS, AND DIFFERENTIAL PROPORTIONING WEIGHERS; PARTS OF WEIGHING SCALES; DATA ENTRY AND MONITORING ELECTRONICS FOR MACHINES, NAMELY, DATA PROCESSORS, WIRELESS ELECTRICAL CONTROLLERS TO MONITOR AND CONTROL THE FUNCTION OF THE AFOREMENTIONED MACHINES AND PARTS; SAFETY DEVICES IN THE NATURE OF OPTOELECTRONIC SENSORS, NAMELY, LIGHT BARRIERS FOR MONITORING AND CONTROLLING MACHINES; ELECTRICAL SWITCHES; COMPUTERS AND THE RELATED PERIPHERY, NAMELY, WIRELESS CONTROLLERS FOR CONTROL AND REGULATION OF THE AFOREMENTIONED GOODS; COMPUTER PROGRAMS RECORDED ON DATA STORAGE MEDIA FOR CONTROLLING AND REGULATING THE AFOREMENTIONED GOODS; REPLACEMENT PARTS OF ALL AFOREMENTIONED GOODS.

FIRST USE ; IN COMMERCE .

INT. CL. 11/U.S. CLS. 13, 21, 23, 31 AND 34

FOR APPARATUS FOR COOLING AND DRYING OF TRANSPORTED MATERIALS AND BULK GOODS, NAMELY, COOLING EVAPORATORS, DEHUMIDIFIERS.

FIRST USE ; IN COMMERCE .
 INT. CL. 12/U.S. CLS. 19, 21, 23, 31, 35 AND 44
 FOR AERIAL CONVEYORS, NAMELY, OVERHEAD TROLLEYS CONSISTING OF A LOOP OF CHAIN OR CABLE SUSPENDED FROM A TRACK AND WITH CARRIERS ATTACHED TO HANG OR CONTAIN PRODUCTS.

FIRST USE ; IN COMMERCE .
 INT. CL. 20/U.S. CLS. 2, 13, 22, 25, 32 AND 50
 FOR NON-METAL CONTAINERS FOR STORAGE AND TRANSPORTATION OF BULK GOODS, FOR COMMERCIAL USE.

FIRST USE ; IN COMMERCE .
 INT. CL. 42/U.S. CLS. 100 AND 101
 FOR TECHNICAL ENGINEERING SERVICES; TECHNICAL PROJECT PLANNING IN THE NATURE OF ENGINEERING SERVICES; TECHNICAL ENGINEERING CONSULTATION; COMPUTER PROGRAMMING; DEVELOPMENT, UPDATING, INSTALLATION AND MAINTENANCE OF COMPUTER SOFTWARE; COMPUTER SOFTWARE CONSULTATION.
 FIRST USE ; IN COMMERCE .

ELEMENTS CORRECTED
 GOODS/SERVICES

4,016,178. REG. 8-23-2011. GENAUDIO, INC. (COLORADO CORPORATION) 8200 S QUEBEC ST., SUITE A3250, CENTENNIAL, CO, 80112, SN 77-160,600. FILED 4-19-2007. PRINCIPAL REGISTER.

ASTOUNDSOUND

THE MARK CONSISTS OF STANDARD CHARACTERS WITHOUT CLAIM TO ANY PARTICULAR FONT, STYLE, SIZE, OR COLOR.

INT. CL. 35/U.S. CLS. 100, 101 AND 102
 FOR POST-PRODUCTION AUDIO EDITING SERVICES FOR COMMERCIALS.
 FIRST USE 10-1-2007; IN COMMERCE 10-1-2007.
 INT. CL. 41/U.S. CLS. 100, 101 AND 107
 FOR POST-PRODUCTION AUDIO EDITING SERVICES IN THE FIELD OF MUSIC, VIDEOS AND FILMS.
 FIRST USE 10-1-2007; IN COMMERCE 10-1-2007.

ELEMENTS CORRECTED
 GOODS/SERVICES

4,016,180. REG. 8-23-2011. GENAUDIO, INC. (COLORADO CORPORATION) 8200 S QUEBEC ST., SUITE A3250, CENTENNIAL, CO, 80112, SN 77-160,640. FILED 4-19-2007. PRINCIPAL REGISTER.

ASTOUNDSTEREO

THE MARK CONSISTS OF STANDARD CHARACTERS WITHOUT CLAIM TO ANY PARTICULAR FONT, STYLE, SIZE, OR COLOR.

INT. CL. 35/U.S. CLS. 100, 101 AND 102

FOR POST-PRODUCTION AUDIO EDITING SERVICES FOR COMMERCIALS.

FIRST USE 1-15-2011; IN COMMERCE 1-15-2011.
 INT. CL. 41/U.S. CLS. 100, 101 AND 107
 FOR POST-PRODUCTION AUDIO EDITING SERVICES IN THE FIELD OF MUSIC, VIDEOS AND FILMS.
 FIRST USE 1-15-2011; IN COMMERCE 1-15-2011.

ELEMENTS CORRECTED
 GOODS/SERVICES

4,021,145. REG. 9-6-2011. CYBERGUN (FRANCE COMPANY) 9-11, RUE HENRI DUNANT, ZI LES BORDES F-91070 BONDOUFLE, FRANCE., SN 79-047,364. FILED 10-19-2007. PRINCIPAL REGISTER.



OWNER OF INTERNATIONAL REGISTRATION 0946511 DATED 10-19-2007, EXPIRES 10-19-2017.

NO CLAIM IS MADE TO THE EXCLUSIVE RIGHT TO USE "SWISS ARMS", APART FROM THE MARK AS SHOWN.

THE CROSS CONTAINED IN THE MARK SHALL NOT BE REPRODUCED IN WHITE ON A RED BACKGROUND, OR IN RED ON A WHITE BACKGROUND, OR IN COLOURS THAT MIGHT BE CONFUSED WITH THE CROSS OF THE SWISS CONFEDERATION OR THE EMBLEM OF THE RED CROSS.

INT. CL. 13/U.S. CLS. 2 AND 9
 FOR FIREARMS SUCH AS PISTOLS, RIFLES, SHOT-GUNS, HANDGUNS, REVOLVERS, CALIBRE AIR GUNS AND PARTS THEREFOR; GAS-FIRED WEAPONS, NAMELY, AIR GUNS, STARTER PISTOLS, SIGNAL WEAPONS IN THE NATURE OF FLARE GUNS, WARNING PISTOLS AND PARTS THEREFOR; BULLETS AND AMMUNITION; ACCESSORIES INCLUDED IN THIS CLASS, NAMELY, RIFLE CASES, RIFLE COVERS, CARTRIDGE BELTS, RIFLE STRAPS, CARTRIDGE CASES; ALL THE AFORESAID GOODS FOR HUNTING, * SELF * DEFENSE, SPORTS RECREATION AND LEISURE, INCLUDED IN THIS CLASS; ELECTRONIC TRIGGER LOCKS FOR USE ON SHOULDER ARMS AND HANDGUNS, AND FOR SHOOTING RANGES, ALL FOR HUNTING, * SELF * DEFENSE, [SPORTS RECREATION] * RECREATIONAL SHOOTING * AND LEISURE.

FIRST USE ; IN COMMERCE .
 INT. CL. 28/U.S. CLS. 22, 23, 38 AND 50
 FOR TOYS, NAMELY, LONG GUNS, MODEL AND REPLICA WEAPONS; TOY SHOT AND MUNITIONS FOR SUCH MODELS AND REPLICAS; TOY MODEL AND REPLICA WEAPONS FOR VIRTUAL SHOOTING; TOY MODEL AND REPLICA WEAPONS FOR USE WITH ELECTRONIC TARGETS AND ELECTRONIC DISPLAYS AND INDIVIDUAL REPLACEMENT PARTS FOR ALL THE AFOREMENTIONED GOODS.

FIRST USE ; IN COMMERCE .

ELEMENTS CORRECTED
 GOODS/SERVICES
 OWNER ADDRESS
 CITIZENSHIP
 ENTITY

4,023,556. REG. 9-6-2011. 7-ELEVEN, INC. (TEXAS CORPORATION) 1722 ROUTH STREET, SUITE 1000, DALLAS, TX, 75201, SN 78-916,143. FILED 6-24-2006. PRINCIPAL REGISTER.

Healthy Gulp

THE MARK CONSISTS OF STANDARD CHARACTERS WITHOUT CLAIM TO ANY PARTICULAR FONT, STYLE, SIZE, OR COLOR.

INT. CL. 5/U.S. CLS. 6, 18, 44, 46, 51 AND 52
FOR PET BEVERAGES, NAMELY, VITAMIN, MINERAL, AND SUPPLEMENT ENRICHED FLAVORED AND PLAIN PURIFIED BOTTLED WATER FOR CATS AND DOGS.

FIRST USE 8-1-2005; IN COMMERCE 11-10-2006.

ELEMENTS CORRECTED

OWNER NAME
OWNER ADDRESS
CITIZENSHIP
ENTITY

4,046,426. REG. 10-25-2011. GREENTECH ENVIRONMENTAL (DELAWARE LIMITED LIABILITY COMPANY) 6124 KINGSPOUT HWY 36, STE 1, GRAY, TN, 37615, SN 85-086,257. FILED 7-16-2010. PRINCIPAL REGISTER.

pureWash

THE MARK CONSISTS OF STANDARD CHARACTERS WITHOUT CLAIM TO ANY PARTICULAR FONT, STYLE, SIZE, OR COLOR.

INT. CL. 11/U.S. CLS. 13, 21, 23, 31 AND 34
FOR WASHING MACHINE WATER TREATMENT DEVICE CONNECTED TO THE COLD WATER INLET TO ELIMINATE NEED FOR DETERGENT.

FIRST USE 7-4-2010; IN COMMERCE 3-9-2011.

ELEMENTS CORRECTED MARK

4,050,249. REG. 11-1-2011. DEVILBISS HEALTHCARE LLC (DELAWARE LIMITED LIABILITY COMPANY) 100 DEVILBISS DRIVE, SOMERSET, PA, 15501, SN 85-065,501. FILED 6-17-2010. PRINCIPAL REGISTER.

AUTO PLUS

THE MARK CONSISTS OF STANDARD CHARACTERS WITHOUT CLAIM TO ANY PARTICULAR FONT, STYLE, SIZE, OR COLOR.

NO CLAIM IS MADE TO THE EXCLUSIVE RIGHT TO USE "AUTO", APART FROM THE MARK AS SHOWN.

INT. CL. 10/U.S. CLS. 26, 39 AND 44

FOR MEDICAL APPARATUS, NAMELY, HOME BREATHING THERAPY DEVICES, NAMELY, CONTINUOUS POSITIVE AIRWAY PRESSURE (CPAP) DEVICES AND BI-LEVEL POSITIVE AIRWAY PRESSURE (BI-PAP) DEVICES.

FIRST USE 9-1-2010; IN COMMERCE 9-1-2010.

ELEMENTS CORRECTED CITIZENSHIP

4,054,508. REG. 11-15-2011. VACOM VAKUUM KOMPONENTEN & MESSTECHNIK GMBH (FED REP GERMANY GMBH) GABELSBERGERSTRASSE 9, 07749 JENA, FED REP GERMANY., SN 79-078,396. FILED 12-24-2009. PRINCIPAL REGISTER.

VACOM

THE MARK CONSISTS OF STANDARD CHARACTERS WITHOUT CLAIM TO ANY PARTICULAR FONT, STYLE, SIZE, OR COLOR.

PRIORITY DATE OF 7-3-2009 IS CLAIMED.

OWNER OF INTERNATIONAL REGISTRATION 1027494 DATED 12-24-2009, EXPIRES 12-24-2019.

INT. CL. 7/U.S. CLS. 13, 19, 21, 23, 31, 34 AND 35
FOR MACHINES FOR CREATING VACUUMS; [MOTORS AND ENGINES NOT FOR LAND VEHICLES; MACHINE COUPLING AND TRANSMISSION COMPONENTS NOT FOR LAND VEHICLES;] PRESSURE REGULATORS AND PRESSURE VALVES AS MACHINE PARTS; VACUUM PUMPS; MACHINE PARTS, NAMELY, ROTARY BUSHINGS FOR VACUUM INSTALLATIONS; VACUUM MANIPULATORS WHICH ENABLE MECHANICAL MOTION IN VACUUM SYSTEMS.

FIRST USE ; IN COMMERCE .

INT. CL. 9/U.S. CLS. 21, 23, 26, 36 AND 38
FOR DATA-PROCESSING EQUIPMENT AND COMPUTERS; VACUUM MEASURING APPARATUS, NAMELY, VACUUM GAUGES AND DISPLAYS, CONTROLLERS, BEAM FLUX MONITORS FOR MONITORING BEAM EQUIVALENT PRESSURES (BEP); THERMAL SENSORS FOR VACUUM MEASURING APPARATUS; CHECKING APPARATUS FOR VACUUM SYSTEMS FOR SAFETY AND SCIENTIFIC PURPOSES, NAMELY, HERMETICALLY SEALED LIGHT TRANSMISSIVE PORTS CONNECTED TO VACUUM SYSTEMS ALLOWING THE OPERATOR TO VIEW A VACUUM PROCESS, TO INITIATE CHEMICAL OR PHYSICAL ACTION USING SPECIFIC ELECTROMAGNETIC WAVELENGTHS, OR TO MAKE MEASUREMENTS OF LIGHT WAVELENGTHS; PIEZO MEMBRANE SENSORS FOR VACUUM METERS; MASS SPECTROMETERS; ELECTROMAGNETIC CONTROL VALVES AND PIEZO-ELECTRIC CONTROL VALVES FOR MASS FLOW METERS AND MASS FLOW REGULATORS, BEING APPARATUS FOR MEASURING, SETTING AND REGULATING PROCESS GASES IN VACUUM SYSTEMS; ANALOG AND DIGITAL THERMAL MASS FLOW METERS AND MASS FLOW CONTROLLERS FOR MEASURING, POSITIONING AND CONTROLLING OF PROCESSED GASES WITHIN A VACUUM SYSTEM; AUTOMATIC VALVES; ION GETTER PUMPS AND SUBLIMATION PUMPS AND CONTROLLERS THEREFOR; SCIENTIFIC APPARATUS AND INSTRUMENTS, NAMELY, HIGH AND ULTRA-HIGH VACUUM CHAMBERS; ELECTRIC CABLES AND ELECTRIC CABLE CONNECTORS; COAXIAL CABLES; PRECISION VACUUM MEASURING APPARATUS; [APPARATUS FOR COMMUTATION OF ELECTRICAL,] MECHANICAL AND OPTICAL SIGNALS, NAMELY, FIBER OPTIC AND ELECTRICAL FEEDTHROUGHS WHICH ENABLE THE TRANSFER OF OPTICAL AND ELECTRICAL SIGNALS INSIDE A HERMETIC CLOSED CHAMBER, AND LINEAR AND ROTARY MECHANICAL FEEDTHROUGHS WHICH ENABLE THE TRANSFER OF MECHANICAL MOTION THROUGH A HERMETIC CLOSED CHAMBER.

FIRST USE ; IN COMMERCE .

INT. CL. 42/U.S. CLS. 100 AND 101

FOR DEVELOPMENT OF VACUUM COMPONENTS, VACUUM MEASURING SYSTEMS AND VACUUM, MEASURING AND CONTROL SYSTEMS FOR OTHERS; MATERIALS TESTING * IN THE FIELD OF VACUUM TECHNOLOGY *; SCIENTIFIC AND TECHNOLOGICAL RESEARCH FOR THE DEVELOPMENT OF VACUUM COMPONENTS AND SYSTEMS FOR OTHERS.

FIRST USE ; IN COMMERCE .

ELEMENTS CORRECTED
GOODS/SERVICES

4,054,537. REG. 11-15-2011. BODEGA COOPERATIVA NUESTRA SEÑORA DE VALVANERA (SPAIN COOPERATIVA) CARRETERA DE MIRANDA, S/N, E-26211 TIRGO, SPAIN., SN 79-085,363. FILED 7-7-2010. PRINCIPAL REGISTER.

TARON

THE MARK CONSISTS OF STANDARD CHARACTERS WITHOUT CLAIM TO ANY PARTICULAR FONT, STYLE, SIZE, OR COLOR.

OWNER OF INTERNATIONAL REGISTRATION 1045834 DATED 7-7-2010, EXPIRES 7-7-2020.

THE WORD(S) "TARON" HAS NO MEANING IN A FOREIGN LANGUAGE.

INT. CL. 33/U.S. CLS. 47 AND 49

FOR ALCOHOLIC BEVERAGES EXCEPT BEERS, NAMELY, WINE * WITH ALCOHOL CONTENT OF NO MORE THAN 20 PERCENT *.

FIRST USE ; IN COMMERCE .

ELEMENTS CORRECTED
GOODS/SERVICES

4,058,178. REG. 11-22-2011. CACTUS CORPORATION (JAPAN CORPORATION) 37-1 NONOUE 3-CHOME, HABIKI-NO-CITY; OSAKA 583-0871, JAPAN., SN 79-090,763. FILED 4-14-2010. PRINCIPAL REGISTER.

D.A.D

PRIORITY DATE OF 1-7-2010 IS CLAIMED.

OWNER OF INTERNATIONAL REGISTRATION 1060528 DATED 4-14-2010, EXPIRES 4-14-2020.

OWNER OF U.S. REG. NOS. 3,485,559 AND 3,518,446.

THE MARK CONSISTS OF "D.A.D." IN STYLIZED FONT WITH THE FIRST LETTER D FACING BACKWARDS.

INT. CL. 3/U.S. CLS. 1, 4, 6, 50, 51 AND 52

FOR PERFUMERY, FRAGRANCE AND INCENSES.

INT. CL. 6/U.S. CLS. 2, 12, 13, 14, 23, 25 AND 50

FOR METAL NAMEPLATES AND DOOR NAMEPLATES.

INT. CL. 9/U.S. CLS. 21, 23, 26, 36 AND 38

FOR CIGAR LIGHTERS FOR AUTOMOBILES; RECORDED VIDEO DISCS AND VIDEO TAPES FEATURING CUSTOMIZED VEHICLES.

FIRST USE ; IN COMMERCE .

INT. CL. 11/U.S. CLS. 13, 21, 23, 31 AND 34

FOR ELECTRIC LAMPS AND OTHER LIGHTING APPARATUS, NAMELY, LIGHTING APPARATUS FOR VEHICLES; AUTOMOTIVE HEADLAMPS; REAR LIGHTS FOR VEHICLES; LED LIGHT ASSEMBLIES FOR AUTOMOBILES.

INT. CL. 18/U.S. CLS. 1, 2, 3, 22 AND 41

FOR FOLDING BRIEFCASES; SHOULDER BAGS, BRIEFCASES, SUITCASES, CARRY-ON BAGS, HANDBAGS, BOSTON BAGS, BACKPACKS; LEATHER SHOPPING BAGS; REUSABLE SHOPPING BAGS; KEY CASES, WALLETS NOT OF PRECIOUS METALS; BUSINESS CARD CASES; VANITY CASES, NOT FITTED.

INT. CL. 20/U.S. CLS. 2, 13, 22, 25, 32 AND 50

FOR [CURTAIN TIE-BACKS IN THE NATURE OF NON-TEXTILE CURTAIN HOLDERS;] CUSHIONS; JAPANESE FLOOR CUSHIONS; PILLOWS.

FIRST USE ; IN COMMERCE .

INT. CL. 21/U.S. CLS. 2, 13, 23, 29, 30, 33, 40 AND 50

FOR COSMETIC UTENSILS, NAMELY, POWDER COMPACTS SOLD EMPTY.

INT. CL. 26/U.S. CLS. 37, 39, 40, 42 AND 50

FOR LACES; RIBBONS, NAMELY, HAIR RIBBONS AND DECORATIVE RIBBONS; BADGES FOR WEAR, NOT OF PRECIOUS METAL, NAMELY, ORNAMENTAL NOVELTY BADGES; BUCKLES FOR CLOTHING.

INT. CL. 28/U.S. CLS. 22, 23, 38 AND 50

FOR TOYS, NAMELY, STUFFED TOYS, MODEL TOY VEHICLES, TOY MODEL VEHICLES AND RELATED ACCESSORIES SOLD AS UNITS; DOLLS.

ELEMENTS CORRECTED
GOODS/SERVICES

4,075,939. REG. 12-27-2011. STARBRANDS NETWORKS, LLC (NEVADA LIMITED LIABILITY COMPANY) 3024 VIA VENEZIA, HENDERSON, NV, 89052, SN 85-039,887. FILED 5-17-2010. PRINCIPAL REGISTER.

LP TUNES^S

SEC. 2(F).

INT. CL. 35/U.S. CLS. 100, 101 AND 102

FOR ONLINE RETAIL STORE SERVICES FEATURING AUDIO PRODUCTS.

FIRST USE 6-10-2004; IN COMMERCE 6-10-2004.

ELEMENTS AMENDED
MARK

4,081,579. REG. 1-10-2012. LA FE FOODS, INC. (DELAWARE CORPORATION) 230 MOONACHIE AVENUE, MOONACHIE, NJ, 07074, SN 76-707,421. FILED 4-26-2011. PRINCIPAL REGISTER.

EL SABOR DE MI TIERRA

THE MARK CONSISTS OF STANDARD CHARACTERS WITHOUT CLAIM TO ANY PARTICULAR FONT, STYLE, SIZE, OR COLOR.

OWNER OF U.S. REG. NO. 2,561,202.

THE ENGLISH TRANSLATION OF "EL SABOR DE MI TIERRA" IS "THE TASTE OF MY HOMETLAND".

INT. CL. 25/U.S. CLS. 22 AND 39

FOR CLOTHING, NAMELY, SHIRTS.

FIRST USE 0-0-2001; IN COMMERCE 0-0-2001.

INT. CL. 29/U.S. CL. 46

FOR CHEESE; OLIVE OILS FOR FOOD; CANNED AND DRIED BEANS; DRIED LENTILS; CANNED AND DRIED PEAS; SOY MILK FOR USE AS A MILK SUBSTITUTE; CANNED FRUIT; BAKED BEANS; REFRIED BEANS; PROCESSED OLIVES; SHOESTRING POTATOES BEING PROCESSED POTATOES; PROCESSED PEPPERS; DRIED PEPPERS BEING PROCESSED PEPPERS.

FIRST USE 0-0-2001; IN COMMERCE 0-0-2001.
INT. CL. 30/U.S. CL. 46

FOR SALT; SUGAR; SPICES; RICE; BROWN RICE; PASTAS; TOMATO SAUCE; SPAGHETTI SAUCE; VINEGAR; WHITE VINEGAR; FRUIT VINEGAR; MINCED GARLIC; DRIED CORN HUSKS FOR TAMALES; DRIED CHILI PEPPERS FOR USE AS SEASONING.

FIRST USE 0-0-2001; IN COMMERCE 0-0-2001.
INT. CL. 32/U.S. CLS. 45, 46 AND 48

FOR NON-ALCOHOLIC BEVERAGES, NAMELY, FRUIT JUICES AND ORANGE JUICE; NON-ALCOHOLIC BEVERAGES BREWED FROM CEREALS, NAMELY, NON-ALCOHOLIC MALT BEVERAGES.

FIRST USE 0-0-2001; IN COMMERCE 0-0-2001.

ELEMENTS CORRECTED
OWNER NAME

4,081,968. REG. 1-10-2012. DE MARIN DE MONTMARIN EDOUARD (FRANCE INDIVIDUAL) 20 AVENUE ROBERT SCHUMAN, F-92100 BOULOGNE-BILLANCOURT, FRANCE., SN 79-098,860. FILED 4-14-2011. PRINCIPAL REGISTER.

Being Who

THE MARK CONSISTS OF STANDARD CHARACTERS WITHOUT CLAIM TO ANY PARTICULAR FONT, STYLE, SIZE, OR COLOR.

PRIORITY DATE OF 4-2-2011 IS CLAIMED.

OWNER OF INTERNATIONAL REGISTRATION 1081276 DATED 4-14-2011, EXPIRES 4-14-2021.

INT. CL. 35/U.S. CLS. 100, 101 AND 102

FOR ADVERTISING FOR SERVICES DEDICATED TO WEBSITES AND TO SOCIAL NETWORKS.

INT. CL. 38/U.S. CLS. 100, 101 AND 104

FOR TELECOMMUNICATIONS ACCESS SERVICES FOR WEBSITES AND SOCIAL NETWORKS.

INT. CL. 41/U.S. CLS. 100, 101 AND 107

FOR TEACHING AND TRAINING SERVICES IN THE FIELD OF WEBSITES AND SOCIAL NETWORKS; ENTERTAINMENT, NAMELY, PROVIDING A WEBSITE FEATURING ENTERTAINMENT INFORMATION * IN CONNECTION WITH THE INTERNET SITES AND SOCIAL NETWORKS *.

FIRST USE ; IN COMMERCE .

ELEMENTS CORRECTED
GOODS/SERVICES

4,085,960. REG. 1-17-2012. PIPISTREL D.O.O. AJDOVSCINA (SLOVENIA LIMITED LIABILITY COMPANY) GORISKA CESTA 50A. SI-5270 AJDOVSCINA, SLOVENIA., SN 79-098,564. FILED 4-11-2011. PRINCIPAL REGISTER.

PANTHERA

THE MARK CONSISTS OF STANDARD CHARACTERS WITHOUT CLAIM TO ANY PARTICULAR FONT, STYLE, SIZE, OR COLOR.

PRIORITY DATE OF 3-29-2011 IS CLAIMED.

OWNER OF INTERNATIONAL REGISTRATION 1080392 DATED 4-11-2011, EXPIRES 4-11-2021.

INT. CL. 12/U.S. CLS. 19, 21, 23, 31, 35 AND 44

FOR [AIRPLANES AND STRUCTURAL PARTS THEREFORE;] * FOUR-SEAT * SPORT [AIRPLANE] * AIRPLANES * [; AIRPLANE PARTS AND SPARE PARTS, NAMELY, FUSELAGES, STEERING GEAR, LANDING GEAR, PROPELLERS, BRAKES, WINGS, LANDING WHEELS] .

FIRST USE ; IN COMMERCE .

ELEMENTS CORRECTED
GOODS/SERVICES

4,088,285. REG. 1-17-2012. JUSTIN JACKSON (UNITED STATES INDIVIDUAL) 204 W. 114TH CT., JENKS, OK, 74037, SN 77-718,101. FILED 4-20-2009. PRINCIPAL REGISTER.

BIG AIR

THE MARK CONSISTS OF STANDARD CHARACTERS WITHOUT CLAIM TO ANY PARTICULAR FONT, STYLE, SIZE, OR COLOR.

INT. CL. 9/U.S. CLS. 21, 23, 26, 36 AND 38

FOR SPORT GOGGLES FOR USE IN SKIING AND SNOWBOARDING.

FIRST USE 11-30-2011; IN COMMERCE 11-30-2011.

INT. CL. 28/U.S. CLS. 22, 23, 38 AND 50

FOR SNOWBOARDS AND SNOWBOARD BINDINGS.
FIRST USE 11-30-2011; IN COMMERCE 11-30-2011.

ELEMENTS CORRECTED
GOODS/SERVICES

4,090,523. REG. 1-24-2012. WILBUR-ELLIS COMPANY (CALIFORNIA CORPORATION) 345 CALIFORNIA STREET, 27TH FLOOR, SAN FRANCISCO, CA. 94104, SN 85-336,748. FILED 6-2-2011. PRINCIPAL REGISTER.



OWNER OF U.S. REG. NOS. 3,005,933 AND 3,085,316.
NO CLAIM IS MADE TO THE EXCLUSIVE RIGHT TO USE "BRAND", APART FROM THE MARK AS SHOWN.

THE MARK CONSISTS OF AN IMAGE OF A LIGHTHOUSE WITH THE WORDS "LIGHTHOUSE BRAND" ARRANGED IN AN ARC/SEMI-CIRCLE, FROM THE 9 O'CLOCK POSITION TO THE 3 O'CLOCK POSITION, ABOVE THE IMAGE.

INT. CL. 1/U.S. CLS. 1

MARCH 27, 2012

U.S. PATENT AND TRADEMARK OFFICE

TM 1411

FOR FERTILIZERS; SOIL AMENDMENTS, EXCLUDING SAND.
FIRST USE 1-1-2004; IN COMMERCE 1-1-2004.

4,097,677. REG. 2-14-2012. COLOPLAST A/S TRADEMARK DEPARTMENT (DENMARK CORPORATION) HOLTEDAM 1, DK-3050 HUMLEBÆKK, DENMARK., SN 79-095,878. FILED 2-18-2011. PRINCIPAL REGISTER.

ELEMENTS CORRECTED
GOODS/SERVICES

4,092,567. REG. 1-24-2012. JLS INTERACTIVE, LLC (NEBRASKA LIMITED LIABILITY COMPANY) 2434 SEWELL STREET, LINCOLN, NE, 68502, SN 85-351,429. FILED 6-21-2011. SUPPLEMENTAL REGISTER.

BODYSMART

eTEE

THE MARK CONSISTS OF STANDARD CHARACTERS WITHOUT CLAIM TO ANY PARTICULAR FONT, STYLE, SIZE, OR COLOR.
INT. CL. 41/U.S. CLS. 100, 101 AND 107
FOR INSTRUCTION IN THE FIELD OF TRANSESOPHAGEAL ECHOCARDIOGRAPHY.
FIRST USE 6-16-2011; IN COMMERCE 6-16-2011.

THE MARK CONSISTS OF STANDARD CHARACTERS WITHOUT CLAIM TO ANY PARTICULAR FONT, STYLE, SIZE, OR COLOR.
PRIORITY DATE OF 9-21-2010 IS CLAIMED.
OWNER OF INTERNATIONAL REGISTRATION 1073337 DATED 2-18-2011, EXPIRES 2-18-2021.
INT. CL. 10/U.S. CLS. 26, 39 AND 44
FOR OSTOMY BAGS AND PARTS AND FITTINGS THEREFORE, NOT INCLUDED IN OTHER CLASSES, NAMELY, BAGS, ATTACHMENT RINGS, CLOSURE RINGS, SKIN PROTECTING SHEETS, BASE PLATES, FILTERS, VALVES, COUPLERS, INTEGRATED CLOSURES AND INTEGRATED OUTLETS.
FIRST USE ; IN COMMERCE .

ELEMENTS CORRECTED
OWNER NAME

ELEMENTS CORRECTED
GOODS/SERVICES

* * * * *

TRADEMARK REGISTRATIONS—NEW CERTIFICATES

New Certificates issued under section 7(d) of the Trademark Act of 1946 for the unexpired term of the original registrations.

3,192,012. VENETIAN NAIL SPA STANDARD CHARAC-
TER MARK. INT. CL. 44. TRIEU, TONY, GRANGER, IN.

REG. 1-2-2007. NEW CERT. SEC. 7(D) TO REGISTRANT.

* * * * *

INDEX OF REGISTRANTS

MARCH 27, 2012

(Registered; Renewed; Canceled; Amended, Corrected, etc.; New Certificates; 12c Publications.)

The designation "U.S. Cl." appearing in this section refers to the U.S. class in effect prior to Sep. 1, 1973 rather than the international class which applies to applications filed on or after that date. For adoption of international classification see notice in the OFFICIAL GAZETTE of Jun. 26, 1973 (911 O.G. TM 210).

(JOHN HINDE) JOHN HINDE LTD., BRAY, COUNTY WICKLOW, IRELAND:
4,119,791, INT. CL. 28.

"BECAUSE WE CARE" MINISTRIES, SCHWENKSVILLE, PA:
4,117,216, PUB. 1-10-2012. INT. CL. 28.

"LA VIS S.C.A." IN SIGLA "L.V. S.C.A." - "C.S.L.S.S. S.C.A." "C.S.L. S.C.A." - "CANLAV S.C.A." - "CIELLE S.C.A.", LAVIS (TN), ITALY:
4,117,723, PUB. 1-10-2012. INT. CL. 33.

A CHARMED LIFE CHILDCARE, INC., SOLANA BEACH, CA, DBA A CHARMED LIFE CHILDCARE, INC.:
4,116,664, PUB. 1-10-2012. INT. CL. 35.

A HOMETOWN PEST CONTROL, INC., PITTSBURGH, PA:
2,967,915, CANC. INT. CL. 37.

A LA MODE, INC., OKLAHOMA CITY, OK:
4,117,495, PUB. 1-10-2012. INT. CL. 42.

A PLACE TO GROW, INC., CONCORD, MA:
4,117,162, PUB. 1-10-2012. INT. CL. 43.

A PLACE TO GROW, INC., SUDBURY, MA:
4,117,163, PUB. 1-10-2012. INT. CL. 43.

A. DUDA & SONS, INC., OVIEDO, FL:
1,185,083. REN. 2-22-12. INT. CL. 31.

A. G. THOMPSON PTY. LTD., MOORABBIN VICTORIA, AUSTRALIA:
1,183,091. REN. 2-17-12. INT. CL. 28.

A. SCHULMAN, INC., AKRON, OH:
4,118,891, INT. CL. 17.

A.K.A. SAUNDERS, INC., BERKELEY, CA, A.K.A. SAUNDERS, INC., BERKELEY, CA:
1,671,555. REN. 2-22-12. INT. CL. 3.

A.L. ENTERPRISES, INC., LAS VEGAS, NV:
4,117,796, PUB. 1-10-2012. INT. CL. 10.

A.M. BEST COMPANY, OLDWICK, NJ:
1,694,286. REN. 2-22-12. INT. CL. 16.

A.P. PHARMA, INC., REDWOOD CITY, CA:
4,118,925, INT. CL. 5.

A.W. FABER-CASTELL USA, INC., CLEVELAND, OH:
4,117,946, PUB. 1-10-2012. INT. CL. 28.

AA ENERGIES, LTD., CENTRAL, HONG KONG, HONG KONG:
4,119,363, INT. CL. 3.

AB INITIO SOFTWARE LLC, LEXINGTON, MA:
4,118,820, INT. CL. 9.

AB SCIEX PTE. LTD., SINGAPORE, SINGAPORE:
4,118,989, INT. CL. 9.

ABBAYHYDE, LLC, WALLS, MS:
4,118,550, PUB. 1-10-2012. INT. CL. 43.

ABBOTT RESPIRATORY LLC, ABBOTT PARK, IL:
2,467,489, CANC. INT. CL. 5.

ABBY'S INC., EUGENE, OR, ABBY'S PIZZA INNS, ROSEBURG, OR:
1,184,216. REN. 2-21-12. INT. CL. 42.

ABC, INC., NEW YORK, NY:
2,627,831. REN. 2-17-12. MULTIPLE CLASS, INT. CLS. 35, 38 AND 41.

ABDULLAIEVA INTERNATIONAL TRADE COMPANY, RANCHO CUCAMONGA, CA, DBA SLEEP & BEYOND:
4,116,892, PUB. 1-10-2012. INT. CL. 24.

ABELA, KEVIN, SAGINAW, MI:
4,119,823, INT. CL. 35.

ABERCROMBIE & FITCH TRADING CO., NEW ALBANY, OH:
2,525,978. REN. 2-22-12. MULTIPLE CLASS, INT. CLS. 3, 25 AND 35.

ABERJE ASSOCIAÇÃO BRASILEIRA DE COMUNICAÇÃO EMPRESARIAL, SÃO PAULO, BRAZIL:
4,119,868, INT. CL. 41.

ABL SA, LUXEMBOURG, LUXEMBOURG:
4,119,566, INT. CL. 9.

ABLE MADE LLC, BROOKLYN, NY:
4,118,285, PUB. 1-10-2012. INT. CL. 35.

ABRAHAM, THOMAS G., MIAMI, FL:
4,117,587, PUB. 1-10-2012. INT. CL. 41.

ABS GLOBAL, INC., DEFOREST, WI, W. R. GRACE & CO.-CONN., NEW YORK, NY:
1,672,241. REN. 2-22-12. INT. CL. 42.

ACADEMY GRAPHIC COMMUNICATION, INC., CLEVELAND, OH:
2,563,528. REN. 2-22-12. INT. CL. 42.

ACADIAN AMBULANCE SERVICE, INC., LAFAYETTE, LA:
4,117,384, PUB. 1-10-2012. MULTIPLE CLASS, INT. CLS. 35, 39, 41, 44 AND 45.

ACCELA COMMUNICATIONS INC, SOUTHBOROUGH, MA:
2,968,065, CANC. INT. CL. 35.

ACCENIA, INC., SANTA CLARA, CA:
2,968,562, CANC. INT. CL. 9.

ACCESS INTELLIGENCE, INC., CARY, NC:
4,117,926, PUB. 1-10-2012. INT. CL. 42.

ACCESSVIA, INC., SEATTLE, WA:
2,967,617, CANC. MULTIPLE CLASS, INT. CLS. 35, 40 AND 42.

ACCO BRANDS CORPORATION, LINCOLNSHIRE, IL:
720,013. REN. 2-22-12. U.S. CL. 37 (INT. CL. 16).

ACCOUTREMENTS LLC, SEATTLE, WA:
2,529,687. REN. 2-22-12. INT. CL. 28.

ACCUNETMORTGAGE.COM LLC, BUTLER, WI:
2,634,227. REN. 2-21-12. INT. CL. 36.
2,648,286. REN. 2-21-12. INT. CL. 36.

ACE CO., LTD., JAPAN:
4,116,854, PUB. 1-10-2012. INT. CL. 18.

ACE CONTROLS, INC., FARMINGTON, MI:
945,185. REN. 2-17-12. U.S. CL. 23 (INT. CL. 7).

ACE SURGICAL SUPPLY CO., INC., BROCKTON, MA:
4,119,354, INT. CL. 10.

ACIONT INC., SALT LAKE CITY, UT:
2,967,393, CANC. INT. CL. 5.

ACME CLOTHING CORPORATION, OXFORD, CT:
4,118,822, INT. CL. 25.

ACP SECRETS INC., MOUNT-ROYAL, QUEBEC, CANADA:
2,468,148, CANC. MULTIPLE CLASS, INT. CLS. 39 AND 42.

ACROMAG INCORPORATED, WIXOM, MI:
4,118,622, PUB. 1-10-2012. INT. CL. 9.
4,118,629, PUB. 1-10-2012. INT. CL. 9.

ACT II JEWELRY, LLC, WOOD DALE, IL:
4,117,337, PUB. 1-10-2012. INT. CL. 35.

ACTIONTEC ELECTRONICS, INC., SUNNYVALE, CA:
4,119,395, INT. CL. 9.

ACTIVANT SOLUTIONS INC., LIVERMORE, CA:
2,686,012, CANC. INT. CL. 9.

- ACTIVE WATER, PAWPAW, MI:
4,117,334, PUB. 1-10-2012. INT. CL. 36.
- ACTV ENTERTAINMENT, INC., SAN FRANCISCO, CA:
2,967,993, CANC. INT. CL. 42.
- AD PEPPER MEDIA INTERNATIONAL N.V., AMSTERDAM, NETHERLANDS:
4,117,233, PUB. 1-10-2012. MULTIPLE CLASS, INT. CLS. 9, 35, 38 AND 42.
- AD REM TECHNOLOGY, FRANCE:
4,116,810, PUB. 1-10-2012. INT. CL. 10.
- ADAMS, BLAIR, SAN ANSELMO, CA:
4,119,634, INT. CL. 41.
- ADASIM INC, CULVER CITY, CA:
4,118,379, PUB. 1-10-2012. MULTIPLE CLASS, INT. CLS. 35 AND 38.
- ADCO, INC., SEDALIA, MO:
2,467,818, CANC. INT. CL. 3.
- ADDBIO AB, LINKÖPING 58330, SWEDEN:
4,117,704, PUB. 1-10-2012. MULTIPLE CLASS, INT. CLS. 5 AND 10.
- ADDGENE, INC., CAMBRIDGE, MA:
4,118,726, PUB. 1-10-2012. MULTIPLE CLASS, INT. CLS. 1, 35 AND 42.
- ADDRESSVISION INC., LA CROSSE, WI:
4,119,151, INT. CL. 9.
- ADLINK TECHNOLOGY INC., TAIPEI, TAIWAN:
2,541,346, REN. 2-22-12. INT. CL. 9.
- ADR INTERNATIONAL PURCHASING CONSULTANTS LIMITED, WALLINGFORD, OXFORDSHIRE OX10 OBS, UNITED KINGDOM:
2,965,482, CANC. INT. CL. 16.
- ADV-TECH BUILDING SYSTEMS, LLC, GOSHEN, IN:
2,968,072, CANC. INT. CL. 19.
- ADVANCE MAGAZINE PUBLISHERS INC., NEW YORK, NY:
4,118,906, INT. CL. 41.
- ADVANCE MODULES (USA), INC., CHINO, CA:
2,467,814, CANC. INT. CL. 9.
- ADVANCE WATCH COMPANY LTD., NEW YORK, NY:
4,119,335, INT. CL. 14.
- ADVANCEPIERRE FOODS, INC., CINCINNATI, OH:
4,118,229, PUB. 1-10-2012. INT. CL. 30.
- ADVENTURE FOREST GROUP LIMITED, SUFFOLK, UNITED KINGDOM:
4,116,702, PUB. 1-10-2012. MULTIPLE CLASS, INT. CLS. 16, 25, 41 AND 43.
- ADVENTURE FOREST GROUP LIMITED, SUFFOLK IP29 5HH, UNITED KINGDOM:
4,116,726, PUB. 1-10-2012. MULTIPLE CLASS, INT. CLS. 16, 25, 41 AND 43.
- ADVENTURES OF HENRY, LLC, OSHKOSH, WI:
4,117,065, PUB. 1-10-2012. INT. CL. 16.
- AEGON DIRECT MARKETING SERVICES, INC., FRAZER, PA:
2,967,787, CANC. MULTIPLE CLASS, INT. CLS. 35 AND 36.
- AERIA SOUND ENVIRONMENTS INC., LADYSMITH, BC, CANADA:
4,117,481, PUB. 1-10-2012. INT. CL. 9.
- AERIELLE IP HOLDINGS, LLC, CINCINNATI, OH:
4,118,821, INT. CL. 9.
- AETNA GROUP S.P.A., 47827 VILLA VERUCCHIO (RN), ITALY:
2,528,939, REN. 2-22-12. INT. CL. 7.
- AFFINION PUBLISHING, LLC, LAS VEGAS, NV:
4,119,243, MULTIPLE CLASS, INT. CLS. 35, 36, 42 AND 45.
4,119,244, MULTIPLE CLASS, INT. CLS. 35, 36, 42 AND 45.
4,119,801, INT. CL. 35.
- AFFINITY GAMING, LLC, LAS VEGAS, NV:
4,117,625, PUB. 1-10-2012. INT. CL. 41.
- AFFLINK, LLC, TUSCALOOSA, AL:
2,659,310, REN. 2-21-12. INT. CL. 3.
2,659,310, CANC. INT. CL. 16.
- AFFYMETRIX, INC., SANTA CLARA, CA:
2,588,652, REN. 2-22-12. INT. CL. 5.
- AFGA CORPORATION, WILMINGTON, MA, AFGA CORPORATION, WILMINGTON, MA:
2,523,855, REN. 2-23-12. INT. CL. 9.
- AFL TELECOMMUNICATIONS, LLC, DUNCAN, SC:
4,118,464, PUB. 1-10-2012. INT. CL. 9.
- AFTERMARKET AUTO PARTS ALLIANCE, INC., SAN ANTONIO, TX:
4,117,986, PUB. 1-10-2012. MULTIPLE CLASS, INT. CLS. 35 AND 37.
- AGARICUS BLAZEI INTERNATIONAL CO., LTD., MINATO-KU TOKYO, JAPAN:
2,467,200, CANC. INT. CL. 29.
- AGARWAL PACKERS & MOVERS LTD., NEW DELHI, INDIA:
4,119,850, INT. CL. 39.
- AGE GROUP LTD., NEW YORK, NY:
2,967,309, CANC. INT. CL. 25.
- AGGIE ANGEL NETWORK, INC., COLLEGE STATION, TX, DBA AGGIE ANGEL NETWORK:
4,117,091, PUB. 10-4-2011. INT. CL. 36.
- AGILIAN, INC., KIRKLAND, WA:
4,117,070, PUB. 1-10-2012. INT. CL. 42.
- AGL RESOURCES INC., ATLANTA, GA:
2,540,852, REN. 2-23-12. INT. CL. 39.
- AGUILAR, FRANK, LOS ANGELES, CA:
2,968,010, CANC. INT. CL. 25.
- AGUSTAWESTLAND S.P.A., ITALY:
4,116,713, PUB. 1-10-2012. MULTIPLE CLASS, INT. CLS. 9 AND 42.
- AHARONI, SHAHPASAND, HERZLIYA, ISRAEL:
2,633,487, REN. 2-22-12. MULTIPLE CLASS, INT. CLS. 7, 9 AND 11.
2,633,487, CANC. INT. CL. 21.
- AHERN, ROY, HUDSON, WI:
4,116,640, PUB. 1-10-2012. INT. CL. 19.
- AHONUI GARDENS, INC., PRINCEVILLE, HI, DBA AHO-NUI GARDENS:
4,116,990, PUB. 1-10-2012. MULTIPLE CLASS, INT. CLS. 29, 31 AND 44.
- AIKO IMPORTERS, INC., MT. PLEASANT, SC:
4,118,261, PUB. 1-10-2012. INT. CL. 33.
- AINSWORTH GAME TECHNOLOGY, NEWINGTON, AUSTRALIA:
4,119,299, INT. CL. 9.
4,119,300, INT. CL. 9.
- AIR CONDITIONING CONTRACTORS OF AMERICA, ARLINGTON, VA:
4,118,988, INT. CL. 16.
- AIR RIDE CRAFT, INC., MIAMI, FL:
2,467,008, CANC. INT. CL. 12.
- AIRCRAFT RUBBER MANUFACTURING, INC., REDMOND, OR:
4,117,920, PUB. 1-10-2012. INT. CL. 12.
- AIREDEP, LLC, ATLANTA, GA:
2,967,744, CANC. INT. CL. 35.
- AIRPORT SHOPPES AND HOTELS CORPORATION, SAN JUAN, PUERTO RICO:
4,118,473, PUB. 1-10-2012. INT. CL. 41.
- AIRTECH INTERNATIONAL INC., HUNTINGTON BEACH, CA:
2,535,500, REN. 2-17-12. INT. CL. 17.
- AIRTECH INTERNATIONAL, INC., HUNTINGTON BEACH, CA, INTERNATIONAL PLASTIC PRODUCTS, INC., CARSON, CA:
1,675,069, REN. 2-17-12. INT. CL. 17.
- AJINOMOTO CO., INC., CHUO-KU, TOKYO, JAPAN:
4,118,857, INT. CL. 1.
- AJT SYSTEMS, INC., FORT LAUDERDALE, FL:
4,119,873, INT. CL. 9.
- AKIN GUMP STRAUSS HAUER & FELD LLP, DALLAS, TX:
4,117,526, PUB. 1-10-2012. INT. CL. 45.
- AKONNA, INC., WINTER PARK, FL:
4,118,405, PUB. 1-10-2012. INT. CL. 42.
- AKZO NOBEL COATINGS INTERNATIONAL B.V., ARNHEM, NETHERLANDS:
4,118,673, PUB. 1-10-2012. INT. CL. 2.
- AL AND DR, INC., ABILENE, TX:
4,119,811, INT. CL. 43.

ALABAMA PROFESSIONAL SERVICES, INC., IRONDALE, AL:
4,118,964, INT. CL. 37.

ALABAMA STATE TREASURER'S OFFICE, MONTGOMERY, AL:
4,116,556, PUB. 1-10-2012. INT. CL. 36.

ALAN GOULD, CALABASAS, CA:
4,118,471, PUB. 1-10-2012. INT. CL. 35.

ALANDA LLC, SCOTCH PLAINS, NJ:
4,119,203, INT. CL. 42.

ALBERT, JOSHUA P, ZEELAND, MI:
4,119,002, INT. CL. 25.

ALBERTO-CULVER USA, INC., MELROSE PARK, IL:
2,524,876. REN. 2-22-12. MULTIPLE CLASS, INT. CLS. 3 AND 5.
2,554,120. REN. 2-21-12. INT. CL. 3.

ALCHEMY ASSOCIATES, L.L.C., ENGLEWOOD, CO:
2,470,018, CANC. INT. CL. 19.

ALDI INC., BATAVIA, IL:
2,558,476. REN. 2-22-12. INT. CL. 30.

ALEBRA, MINNEAPOLIS, MN:
3,138,335, CANC. INT. CL. 45.

ALEBRA TECHNOLOGIES, INC., MINNEAPOLIS, MN:
3,147,749, CANC. INT. CL. 45.

ALEJANDRO HERRERA DOHRENBURG, REYNOSA, TAMAULIPAS, MEXICO:
4,118,340, PUB. 1-10-2012. MULTIPLE CLASS, INT. CLS. 29 AND 43.

ALEX RINK GMBH & CO. KG, FED REP GERMANY:
2,967,215.

ALEXANDER & HORNUNG, INC., ST. CLAIR SHORES, MI:
4,118,272, PUB. 1-10-2012. INT. CL. 29.

ALEXTON INCORPORATED, ALEXANDRIA, VA:
4,117,039, PUB. 1-10-2012. MULTIPLE CLASS, INT. CLS. 35, 36 AND 42.

ALGORITHMICA RESEARCH AB, STOCKHOLM, SWEDEN:
4,118,489, PUB. 1-10-2012. INT. CL. 9.

ALI KHAN DESIGNS, INC., NEW YORK, NY:
2,468,460, CANC. INT. CL. 14.

ALL NATURAL MAINE ROOT, LLC, AUSTIN, TX:
4,117,935, PUB. 1-10-2012. INT. CL. 32.

ALL POINTS MEDIA WORKS, LLC, CHESTERFIELD, MI:
4,117,447, PUB. 1-10-2012. INT. CL. 9.

ALL PURPOSE PLUMBING LLC, TACOMA, WA:
4,117,157, PUB. 1-10-2012. INT. CL. 37.

ALL REAL ESTATE SOLUTIONS, LLC, MAYFIELD VILLAGE, OH:
4,117,541, PUB. 1-10-2012. INT. CL. 36.

ALL WEATHER SAFETY WHISTLES, ST. LOUIS, MO:
4,117,688, PUB. 1-10-2012. INT. CL. 41.

ALLEGHANY PHARMACAL CORPORATION, GREAT NECK, NY:
2,967,928, CANC. INT. CL. 3.

ALLEGHENY COUNTY DISTRICT ATTORNEY'S OFFICE, PITTSBURGH, PA:
4,119,557, INT. CL. 41.

ALLEGHENY VALLEY BASEBALL CLUB, INC., PITTSBURGH, PA:
4,119,192, MULTIPLE CLASS, INT. CLS. 16 AND 41.

ALLGOOD PROVISIONS LLC, PARK CITY, UT, DBA ALLGOOD PROVISIONS:
4,117,369, PUB. 1-10-2012. INT. CL. 29.

ALLIANCE FOR COFFEE EXCELLENCE, INC., THE, MISSOULA, MT:
2,540,624. REN. 2-21-12. INT. CL. 30.

ALLIANCE FOR EARTH, LIFE, LIBERTY & ADVOCATION, INC., NORTH PORT, FL:
4,119,864, INT. CL. 35.

ALLIANCE SECURITY PRODUCTS, INC., NEW YORK, NY:
2,967,558, CANC. INT. CL. 9.

ALLIANT ENERGY CORPORATION, MADISON, WI:
2,967,517, CANC. MULTIPLE CLASS, INT. CLS. 37 AND 42.

ALLIANT SURGICAL PRODUCTS, LLC, RICHLAND, MI:
4,119,679, INT. CL. 10.

ALLIED MINERAL PRODUCTS, INC., COLUMBUS, OH:
2,536,792. REN. 2-22-12. INT. CL. 19.

ALLMAX NUTRITION, INC., ONTARIO, M2N 6N4, CANADA:
4,117,025, PUB. 1-10-2012. INT. CL. 5.
4,117,026, PUB. 1-10-2012. INT. CL. 5.

ALLOCATION SERVICES, INC., TAMPA, FL:
4,117,816, PUB. 1-10-2012. MULTIPLE CLASS, INT. CLS. 35 AND 36.

ALLSTATE INSURANCE COMPANY, NORTHBROOK, IL:
4,119,732, MULTIPLE CLASS, INT. CLS. 37 AND 39.
4,119,745, INT. CL. 36.

ALPHATEST CORPORATION, SHELTON, WA:
2,468,068, CANC. INT. CL. 9.

ALSCO INC., SALT LAKE CITY, UT:
4,119,141, MULTIPLE CLASS, INT. CLS. 35, 37 AND 45.
4,119,249, MULTIPLE CLASS, INT. CLS. 35, 37 AND 45.

ALSTOM TRANSPORT SA, F-92300 LEVALLOIS-PERRET, FRANCE:
4,116,736, PUB. 1-10-2012. MULTIPLE CLASS, INT. CLS. 9, 12, 37 AND 39.

ALTA VIA CONSULTING, LLC, KNOXVILLE, TN:
2,538,959. REN. 2-23-12. MULTIPLE CLASS, INT. CLS. 35, 41 AND 42.

ALTEON INC., PARSIPPANY, NJ:
2,967,657, CANC. INT. CL. 5.

ALTOS RESEARCH, LLC, MOUNTAIN VIEW, CA:
4,117,579, PUB. 1-10-2012. INT. CL. 42.
4,117,580, PUB. 1-10-2012. INT. CL. 41.

ALVA-AMCO PHARMACAL COS., INC., NILES, IL:
4,119,219, INT. CL. 5.

ALVAREZ, JAMES, ATLANTA, GA:
4,118,059, PUB. 1-10-2012. INT. CL. 43.

AMCOL INTERNATIONAL CORPORATION, HOFFMAN ESTATES, IL:
1,713,656. REN. 2-22-12. INT. CL. 17.

AMCOR LIMITED, AUSTRALIA:
2,967,231.

AMER S.P.A., 36078 VALDAGNO (VI), ITALY:
2,580,812. REN. 2-22-12. MULTIPLE CLASS, INT. CLS. 7 AND 12.

AMERICA'S JUNIOR MISS PROGRAM, INC., MOBILE, AL:
4,116,928, PUB. 1-10-2012. MULTIPLE CLASS, INT. CLS. 14 AND 25.

AMERICA'S NEWS NETWORK, LAS VEGAS, NV:
4,119,752, INT. CL. 41.
4,119,753, INT. CL. 41.

AMERICAAT.COM, LLC, LAS VEGAS, NV:
2,967,378, CANC. INT. CL. 35.

AMERICAN ACADEMY OF PEDIATRICS, ELK GROVE VILLAGE, IL:
4,117,243, PUB. 1-10-2012. MULTIPLE CLASS, INT. CLS. 16 AND 41.
4,117,244, PUB. 1-10-2012. MULTIPLE CLASS, INT. CLS. 16 AND 41.
4,117,245, PUB. 1-10-2012. INT. CL. 41.

AMERICAN ASSOCIATION OF MUSEUMS, WASHINGTON, DC:
2,468,001, CANC. MULTIPLE CLASS, INT. CLS. 16 AND 41.

AMERICAN AUTOMOBILE ASSOCIATION, INC., HEATHROW, FL:
4,118,727, PUB. 1-10-2012. INT. CL. 35.

AMERICAN COLLEGE OF CARDIOLOGY FOUNDATION, WASHINGTON, DC:
2,965,568, CANC. INT. CL. 42.

AMERICAN COLLEGE OF SURGEONS, CHICAGO, IL:
1,708,063. REN. 2-22-12. INT. CL. 16.
1,735,346. REN. 2-22-12. INT. CL. 41.
1,736,449. REN. 2-22-12. INT. CL. 16.

AMERICAN COTTON GROWERS, A DIVISION OF PLAINS COTTON COOPERATIVE ASSOCIATION, LUBBOCK, TX:
4,118,582, PUB. 1-10-2012. INT. CL. 25.

AMERICAN DAIRY QUEEN CORPORATION, EDINA, MN:
728,894. REN. 2-22-12. U.S. CL. 46 (INT. CL. 30).

AMERICAN DAIRY QUEEN CORPORATION, MINNEAPOLIS, MN:
1,191,280. REN. 2-19-12. INT. CL. 30.

AMERICAN EXCELSIOR COMPANY, ARLINGTON, TX:
1,739,639. REN. 2-20-12. MULTIPLE CLASS, INT. CLS. 19

- AND 22.
- AMERICAN EXPRESS MARKETING & DEVELOPMENT CORP., NEW YORK, NY:
4,118,461, PUB. 1-10-2012. INT. CL. 41.
4,118,463, PUB. 1-10-2012. INT. CL. 41.
4,119,522, INT. CL. 39.
4,119,523, INT. CL. 39.
4,119,524, INT. CL. 39.
4,119,525, INT. CL. 39.
- AMERICAN FOODSERVICE CONCEPTS CORP., PISCATAWAY, NJ:
2,467,392, CANC. MULTIPLE CLASS, INT. CLS. 29 AND 30.
- AMERICAN FRUITS AND FLAVORS, PACOIMA, CA, DBA AMERICAN FRUIT PROCESSORS:
2,546,102, REN. 2-22-12. INT. CL. 25.
2,546,104, REN. 2-22-12. INT. CL. 25.
- AMERICAN FUNDS DISTRIBUTORS, INC., LOS ANGELES, CA:
2,627,929, REN. 2-22-12. INT. CL. 36.
- AMERICAN GEOPHYSICAL UNION, WASHINGTON, DC:
4,117,280, PUB. 1-10-2012. INT. CL. 41.
- AMERICAN GRATING, LLC, HENDERSON, NV:
4,117,642, PUB. 1-10-2012. INT. CL. 40.
- AMERICAN HALAL CO., INC., STAMFORD, CT:
4,119,722, INT. CL. 29.
- AMERICAN HALAL COMPANY, INC., STAMFORD, CT:
4,117,135, PUB. 1-10-2012. INT. CL. 35.
- AMERICAN HUMANE ASSOCIATION, WASHINGTON, DC:
2,526,201, REN. 2-23-12. INT. CL. 42.
- AMERICAN INGREDIENTS COMPANY, KANSAS CITY, MO:
2,467,681, CANC. INT. CL. 1.
- AMERICAN INTERNATIONAL GROUP, INC., NEW YORK, NY:
2,567,174, REN. 2-17-12. INT. CL. 28.
- AMERICAN INTERNATIONAL INDUSTRIES, LOS ANGELES, CA, NESTLE-LE MUR COMPANY, THE, NEW YORK, NY:
552,557, REN. 2-21-12. U.S. CL. 51 (INT. CL. 3).
- AMERICAN INTERNATIONAL INDUSTRIES, COMMERCE, CA:
4,119,396, INT. CL. 3.
- AMERICAN LABELMARK COMPANY, CHICAGO, IL:
1,669,130, REN. 2-22-12. INT. CL. 6.
1,670,037, REN. 2-22-12. INT. CL. 6.
- AMERICAN LIBERTY BAIL BONDS, INC., WHITTIER, CA:
4,118,643, PUB. 1-10-2012. INT. CL. 36.
4,118,647, PUB. 1-10-2012. INT. CL. 36.
- AMERICAN MOTHERS INC., WASHINGTON, DC:
1,183,253, REN. 2-22-12. INT. CL. 41.
- AMERICAN RADIO RELAY LEAGUE, INCORPORATED, NEWINGTON, CT:
2,531,026, REN. 2-17-12. INT. CL. 42.
2,555,797, REN. 2-17-12. INT. CL. 42.
- AMERICAN RECREATION PRODUCTS, INC., CHESTERFIELD, MO:
4,119,015, INT. CL. 18.
4,119,016, INT. CL. 18.
- AMERICAN SHETLAND PONY CLUB, INC., THE, MORTON, IL:
2,665,815, REN. 2-22-12. INT. CL. 35.
2,665,816, REN. 2-22-12. INT. CL. 35.
2,665,817, REN. 2-22-12. INT. CL. 35.
- AMERICAN SHIPBUILDING ASSOCIATION, WASHINGTON, DC:
2,468,357, CANC. INT. CL. 42.
- AMERICAN SOCIETY OF NEPHROLOGY, WASHINGTON, DC:
4,119,821, INT. CL. 41.
- AMERICAN TOOTH INDUSTRIES, OXNARD, CA:
727,282, REN. 2-19-12. U.S. CL. 44 (INT. CLS. 5, 8, 10 AND 12).
- AMERICAN VINTAGE WINE BISCUITS, INC., LONG ISLAND CITY, NY:
1,669,646, REN. 2-21-12. INT. CL. 30.
- AMERICAN WAY MARKETING LLC, ELKHART, IN:
4,118,601, PUB. 1-10-2012. INT. CL. 15.
- AMERICAN YOUTH HOSTELS, INC., SILVER SPRING, MD, DBA HOSTELLING INTERNATIONAL USA:
4,118,635, PUB. 1-10-2012. INT. CL. 43.
4,118,637, PUB. 1-10-2012. INT. CL. 43.
4,118,639, PUB. 1-10-2012. INT. CL. 43.
4,118,644, PUB. 1-10-2012. INT. CL. 43.
4,118,648, PUB. 1-10-2012. INT. CL. 43.
4,118,669, PUB. 1-10-2012. INT. CL. 43.
- AMERICINN INTERNATIONAL, LLC, CHANHASSEN, MN:
4,117,119, PUB. 1-10-2012. INT. CL. 35.
- AMERIMAX HOME PRODUCTS, INC., DULUTH, GA:
4,118,710, PUB. 1-10-2012. INT. CL. 11.
- AMERISOURCE HERITAGE CORPORATION, WILMINGTON, DE:
4,118,754, INT. CL. 35.
- AMERISRAEL CAPITAL MANAGEMENT LLC, NEW YORK, NY, AKA SHARED VALUES FUND:
4,118,069, PUB. 1-10-2012. INT. CL. 36.
- AMES TRUE TEMPER, INC., CAMP HILL, PA:
4,119,325, INT. CL. 8.
4,119,890, INT. CL. 8.
- AMETEK, INC., BERWYN, PA, TECHNITROL INVESTMENTS, INC., WILMINGTON, DE:
1,677,436, REN. 2-17-12. INT. CL. 9.
- AMETEK, INC., PAOLI, PA:
2,560,072, REN. 2-22-12. INT. CL. 9.
- AMI GE INTERNATIONAL, S. DE R.L. DE C.V., 64000 MONTERREY, N.L., MEXICO:
1,668,302, REN. 2-17-12. INT. CL. 9.
- AMIN, GRACE, WASHINGTON, DC, AKA GRACE AMAZIN:
4,119,575, INT. CL. 35.
- AMMASH, SAM, COMMERCE CITY, CO, FORMERLY AMMASH, WISSAM:
4,117,593, PUB. 1-10-2012. INT. CL. 41.
- AMMEX, TUKWILA, WA:
2,526,524, REN. 2-22-12. INT. CL. 10.
- AMOREPACIFIC CORPORATION, SEOUL, REPUBLIC OF KOREA:
2,468,046, CANC. INT. CL. 3.
4,116,879, PUB. 1-10-2012. INT. CL. 3.
4,117,052, PUB. 1-10-2012. INT. CL. 3.
- AMTROL LICENSING INC., WEST WARWICK, RI:
4,119,394, MULTIPLE CLASS, INT. CLS. 6, 9 AND 11.
- AN-JYE COMPANY LTD, TORONTO ONTARIO, CANADA:
4,116,924, PUB. 1-10-2012. INT. CL. 9.
- ANABOLIC VIDEO PRODUCTIONS, INC., CHATSWORTH, CA:
2,968,265, CANC. INT. CL. 9.
- ANAND PAG INC, IRVING, TX:
4,119,067, INT. CL. 9.
4,119,068, INT. CL. 9.
4,119,069, INT. CL. 9.
- ANANTA AH WINE INCORPORATED, SAN LUIS OBISPO, CA:
4,118,941, INT. CL. 33.
- ANAREN, INC., EAST SYRACUSE, NY:
2,654,000, REN. 2-21-12. INT. CL. 9.
- ANAVISTA ENTERTAINMENT LLC, NEW YORK, NY:
2,525,865, REN. 2-22-12. INT. CL. 41.
- ANDALYZE, INC., CHAMPAIGN, IL:
4,118,946, INT. CL. 9.
4,118,947, INT. CL. 9.
4,118,948, INT. CL. 9.
- ANDERSON HOOPER, TANYA, CARROLLTON, TX:
4,118,732, PUB. 1-10-2012. INT. CL. 41.
- ANDERSON, KENT G., BISMARCK, ND:
2,845,269, CANC. INT. CL. 38.
- ANDERSON, LORI, EASTON, MD, DBA LORI ANDERSON DESIGNS LLC:
4,117,156, PUB. 1-10-2012. INT. CL. 41.
- ANDREW MICHAEL INVESTIGATIONS, INC., TAMPA, FL:
2,967,612, CANC. INT. CL. 45.
- ANDREW MITCHELL & COMPANY, LLC, CONCORD, MA, FORMERLY CONCIERGE REALTY PARTNERS, LLC:
4,119,336, INT. CL. 36.
4,119,337, INT. CL. 36.

ANDREWS MCMEEL PUBLISHING, LLC, KANSAS CITY, MO:
4,119,730, INT. CL. 16.

ANDRITZ AUTOMATION INC., DECATUR, GA:
2,522,922, REN. 2-17-12, INT. CL. 9.

ANGEL KIT FOUNDATION, INC, CELEBRATION, FL:
4,117,527, PUB. 1-10-2012, INT. CL. 16.

ANIMAL FARM FOUNDATION, INC., BANGALL, NY:
4,116,914, PUB. 1-10-2012, MULTIPLE CLASS, INT. CLS. 41 AND 43.

ANIXTER-REAL ESTATE, INC., GLENVIEW, IL:
1,652,696, REN. 2-21-12, INT. CL. 42.

ANNABEL LANGBEIN, REMUERA, AUCKLAND, NEW ZEALAND:
4,119,052, INT. CL. 16.

ANSWERS IN GENESIS, INC., PETERSBURG, KY:
4,117,277, PUB. 1-10-2012, INT. CL. 16.

ANTOFAGASTA MINERALS S.A., LAS CONDES, SANTIAGO, CHILE:
4,116,917, PUB. 1-10-2012, INT. CL. 6.
4,116,918, PUB. 1-10-2012, INT. CL. 14.
4,116,919, PUB. 1-10-2012, INT. CL. 37.

ANZLOWAR, DARA E., SOLVANG, CA, DBA HOODOO ROOTS:
4,117,647, PUB. 1-10-2012, INT. CL. 3.

AOL INC., DULLES, VA:
4,119,087, INT. CL. 35.

AOL LLC, DULLES, VA:
2,967,308, CANC. INT. CL. 42.

APEX BIOTECHNOLOGY CORPORATION, HSINCHU CITY, TAIWAN:
4,117,887, PUB. 1-10-2012, MULTIPLE CLASS, INT. CLS. 5 AND 10.

APEX ENERGETICS, INC., IRVINE, CA:
2,542,698, REN. 2-19-12, INT. CL. 5.

APEX WATERJETTING TECHNOLOGIES, INC., STUART, FL:
4,117,498, PUB. 1-10-2012, INT. CL. 40.

APP CUISINE, LLC, CARY, NC:
4,119,529, INT. CL. 42.

APPLE INC., CUPERTINO, CA:
4,119,260, MULTIPLE CLASS, INT. CLS. 35, 38, 41, 42 AND 45.

APPLICA CONSUMER PRODUCTS, INC., MIRAMAR, FL:
2,468,527, CANC. INT. CL. 11.

APPLICATION CRAFT UK LTD, BINTON, UNITED KINGDOM:
4,117,236, PUB. 1-10-2012, INT. CL. 9.

APPLIED EXTRUSION TECHNOLOGIES, INC., PEABODY, MA:
2,967,549, CANC. INT. CL. 17.

APPLIED FIRE TECHNOLOGIES, LLC, COPPELL, TX:
4,119,547, INT. CL. 9.

APPLIED MATERIAL, SANTA CLARA, CA:
2,968,481, CANC. INT. CL. 7.

APPLIGENT, INC., LANDSDOWNE, PA:
2,464,096, REN. 2-21-12, INT. CL. 9.

APPLOFF ENTERTAINMENT, INC., LOS ANGELES, CA:
4,116,637, PUB. 1-10-2012, INT. CL. 25.

APPSOLUTE MADNESS, INC., HOUSTON, TX:
4,119,725, INT. CL. 42.

APTSOFT CORPORATION, BURLINGTON, MA:
2,968,094, CANC. INT. CL. 9.

AQUA CAPITAL MANAGEMENT LP, OMAHA, NE:
4,118,517, PUB. 1-10-2012, INT. CL. 36.

AQUATIC FEATURES, INC., AUSTIN, TX:
4,117,631, PUB. 1-10-2012, INT. CL. 37.

ARAI & COMPANY, INC., CHIKUSA-KU, NAGOYA 464, JAPAN:
1,213,243, REN. 2-17-12, INT. CL. 15.

ARANET, INC., HOPKINS, MN:
4,118,717, PUB. 1-10-2012, INT. CL. 41.

ARBI, JANEZ, TEMPE, AZ:
4,116,886, PUB. 1-10-2012, INT. CL. 11.

ARCELORMITTAL FLAT CARBON EUROPE SA, L-2930 LUXEMBOURG, LUXEMBOURG:
4,116,818, PUB. 1-10-2012, MULTIPLE CLASS, INT. CLS. 6, 12 AND 40.

ARCH CAPITAL GROUP (U.S.) INC., NEW YORK, NY:
4,118,704, PUB. 1-10-2012, INT. CL. 36.

ARCHERY INNOVATIONS, MCINTOSH, MN:
4,118,195, PUB. 1-10-2012, INT. CL. 28.

ARCHIE'S LAKESHORE BAKERY INC., CLEVELAND, OH:
4,118,189, PUB. 1-10-2012, INT. CL. 35.

ARCOR S.A.I.C., (1006) BUENOS AIRES, ARGENTINA:
2,967,520, CANC. INT. CL. 30.

ARCSOFT, INC., FREMONT, CA:
2,525,652, REN. 2-21-12, INT. CL. 9.

ARE YOU DENSE, INC., WOODBURY, CT:
4,119,231, MULTIPLE CLASS, INT. CLS. 16, 25, 35, 36 AND 44.

ARES SPORTSWEAR, LTD., COLUMBUS, OH:
2,526,607, REN. 2-22-12, MULTIPLE CLASS, INT. CLS. 40 AND 42.

ARES TRADING, S.A., VAUMARCUS, SWITZERLAND:
2,968,399, CANC. INT. CL. 44.

ARGEE CORPORATION, SANTEE, CA:
1,657,425, REN. 2-23-12, INT. CL. 19.

ARGENTO SC BY SICURA INC., NEW YORK, NY:
4,117,247, PUB. 1-10-2012, MULTIPLE CLASS, INT. CLS. 16 AND 20.

ARGUETA SOSA, HILDAN DAVID, QUETZALTENANGO, GUATEMALA:
4,118,013, PUB. 1-10-2012, INT. CL. 29.

ARIXMAR, LLC, LADERA RANCH, CA:
4,117,258, PUB. 1-10-2012, INT. CL. 45.

ARIZONA MANUFACTURING & EMBROIDERY, INC., TEMPE, AZ:
4,119,317, INT. CL. 28.

ARIZONA MEDIA CREDIT UNION, PHOENIX, AZ:
2,968,484, CANC. INT. CL. 36.

ARJO WIGGINS FINE PAPERS LIMITED, UNITED KINGDOM:
4,116,710, PUB. 1-10-2012, MULTIPLE CLASS, INT. CLS. 16, 35, 41 AND 45.

ARLA FOODS, INC., BASKING RIDGE, NJ:
1,671,922, REN. 2-22-12, INT. CL. 29.

ARLEN, MICHAEL W., LOS ANGELES, CA, DBA ARLEN NUTRACEUTICALS:
4,118,911, INT. CL. 5.
4,118,931, INT. CL. 5.

ARMSTRONG MEDICAL LIMITED, COLERAINE BT52 1BS, UNITED KINGDOM:
4,117,934, PUB. 1-10-2012, INT. CL. 10.
4,117,939, PUB. 1-10-2012, INT. CL. 10.
4,119,830, INT. CL. 10.

ARMY AND AIR FORCE EXCHANGE SERVICE, DALLAS, TX:
4,116,632, PUB. 1-10-2012, MULTIPLE CLASS, INT. CLS. 41 AND 44.

ARNE, INC., LAGUNA HILLS, CA:
2,529,987, REN. 2-21-12, INT. CL. 35.

ARNOLD NUTRITION MANAGEMENT GROUP, LLC, HOLLYWOOD, FL:
4,119,703, INT. CL. 5.

ARNOLD'S HOME IMPROVEMENT, TOLEDO, OH:
4,117,716, PUB. 1-10-2012, INT. CL. 37.

ARROW INTERNATIONAL INVESTMENT CORP., WILMINGTON, DE:
4,119,855, INT. CL. 44.

ARRUDA, AIRTON O, ANN ARBOR, MI:
4,118,654, PUB. 1-10-2012, INT. CL. 10.

ART AND FRAME OF FALLS CHURCH, LLC, FALLS CHURCH, VA:
4,117,743, PUB. 1-10-2012, INT. CL. 40.
4,117,744, PUB. 1-10-2012, INT. CL. 40.

ARTE DE MEXICO, INC., BURBANK, CA:
2,968,350, CANC. INT. CL. 35.

ARTHROSURFACE INCORPORATED, FRANKLIN, MA:
4,119,383, INT. CL. 10.

ARTHUR GROOM & CO., INC., RIDGEWOOD, NJ:
4,117,763, PUB. 1-10-2012, INT. CL. 14.

ARTSORGANISM, INC., CORAL GABLES, FL:
4,117,547, PUB. 1-10-2012, INT. CL. 42.

ARUSA INTERNATIONAL, INC., MIAMI, FL:
2,557,870, REN. 2-22-12, MULTIPLE CLASS, INT. CLS. 24

- AND 25.
ARVCO CONTAINER CORPORATION, KALAMAZOO, MI:
2,662,627. REN. 2-22-12. INT. CL. 16.
- ASAHI KASEI KURARAY MEDICAL CO. LTD., TOKYO
101-8101, JAPAN:
4,119,010, INT. CL. 10.
- ASC PROFILES, INC., WEST SACRAMENTO, CA, ASC
PACIFIC INC., W. SACRAMENTO, CA:
1,692,402. REN. 2-23-12. INT. CL. 6.
- ASCEND PERFORMANCE MATERIALS LLC, HOUSTON,
TX, MONSANTO COMPANY, ST. LOUIS, MO:
1,183,834. REN. 2-22-12. INT. CL. 22.
- ASECA AG, SWITZERLAND:
4,000,559, COR. MULTIPLE CLASS, INT. CLS. 1, 3, 5, 7,
11, 32, 40 AND 44.
- ASEFUDDIN, MOHAMMED, BROOKLYN, NY:
4,118,338, PUB. 1-10-2012. INT. CL. 25.
- ASHLAND LICENSING AND INTELLECTUAL PROPERTY
LLC, DUBLIN, OH, CHEMISCHE FABRIK STOCKHAU-
SEN & CIE, KREFELD, FED REP GERMANY:
1,193,821. REN. 2-22-12. INT. CL. 1.
- ASHLAND LICENSING AND INTELLECTUAL PROPERTY
LLC, DUBLIN, OH, ICI CHEMICALS & POLYMERS
LIMITED, CHESHIRE WA7 4QF, ENGLAND:
1,678,177. REN. 2-23-12. INT. CL. 1.
- ASHLAND LICENSING AND INTELLECTUAL PROPERTY
LLC, DUBLIN, OH:
2,541,131. REN. 2-17-12. INT. CL. 1.
2,649,910. REN. 2-23-12. INT. CL. 1.
- ASICS CORPORATION, CHUO-KU, KOBE, JAPAN:
4,118,844, INT. CL. 24.
4,118,845, INT. CL. 25.
- ASK CHEMICALS L.P., DUBLIN, OH, ASHLAND OIL, INC.,
RUSSELL, KY:
1,737,869. REN. 2-23-12. INT. CL. 1.
- ASK S.A., SOPHIA ANTIPOLIS, VALBONNE, FRANCE:
2,965,469, CANC. MULTIPLE CLASS, INT. CLS. 9, 16
AND 38.
- ASK US MEDIA LLC, KIRKLAND, WA:
4,119,749, INT. CL. 9.
- ASSET CONTROL IRELAND LIMITED, DUBLIN 2, IRE-
LAND:
4,118,960, MULTIPLE CLASS, INT. CLS. 9, 16, 35, 36 AND
39.
- ASSISTED RECOVERY CENTERS OF AMERICA, ST.
LOUIS, MO, AKA ARCA:
4,117,122, PUB. 1-10-2012. INT. CL. 44.
- ASSOCIATED MATERIALS, LLC, CUYAHOGA FALLS, OH:
4,117,222, PUB. 1-10-2012. INT. CL. 19.
- ASSURANT, INC., NEW YORK, NY:
4,119,310, INT. CL. 36.
4,119,311, INT. CL. 36.
- AT&T INTELLECTUAL PROPERTY II, L.P., RENO, NV:
2,968,011, CANC. INT. CL. 42.
2,968,012, CANC. INT. CL. 42.
2,968,161, CANC. INT. CL. 9.
- ATAS INTERNATIONAL, INC., ALLENTOWN, PA:
4,118,547, PUB. 1-10-2012. INT. CL. 6.
- ATEX TECHNOLOGIES, INC., PINE BLUFF, NC:
4,117,599, PUB. 1-10-2012. INT. CL. 10.
- ATKINS NUTRITIONALS, INC., RONKONKOMA, NY:
2,967,774, CANC. INT. CL. 5.
- ATLANCO, INC., MARIETTA, GA:
4,119,326, INT. CL. 35.
- ATLANTA ICEPLEX CORP., DULUTH, GA:
4,118,602, PUB. 1-10-2012. INT. CL. 41.
- ATLANTIC PAPER COMPANY "ATCO" B.V., NETHER-
LANDS:
4,116,696, PUB. 1-10-2012. INT. CL. 9.
- ATLAS IMPORTS, L.L.C., WATERFORD, MI:
4,117,724, PUB. 1-10-2012. INT. CL. 33.
- ATLAS MANUFACTURING, INC., ALAPAHA, GA:
4,116,655, PUB. 1-10-2012. INT. CL. 6.
- ATTERRO, INC., MINNEAPOLIS, MN:
1,194,437. REN. 2-21-12. INT. CL. 35.
- ATTITUDE MEASUREMENT CORPORATION, BLUE BELL,
PA:
4,118,357, PUB. 1-10-2012. INT. CL. 35.
- ATTORNEY'S LEGAL SUPPORT SERVICES, INC., MIAMI,
FL:
4,117,095, PUB. 1-10-2012. INT. CL. 45.
- ATW SECURITY, WOBURN, MA:
2,967,645, CANC. INT. CL. 9.
- ATX NETWORKS CORP., AJAX, ONTARIO, CANADA:
4,116,903, PUB. 1-10-2012. INT. CL. 9.
- AU MERROW CORPORATION, LOS ANGELES, CA, DBA
DANIEL RAINN:
4,117,691, PUB. 1-10-2012. INT. CL. 25.
- AUDIBLE, INC., NEWARK, NJ:
4,118,905, MULTIPLE CLASS, INT. CLS. 9, 35, 38 AND 41.
- AUDIO VISUAL INDULGENCE, LLC, MINEOLA, NY:
2,968,109, CANC. INT. CL. 41.
- AUDIOMICRO, INC., SHERMAN OAKS, CA:
4,118,365, PUB. 1-10-2012. INT. CL. 45.
- AUGUST STORCK KG, FED REP GERMANY:
4,116,803, PUB. 1-10-2012. INT. CL. 30.
- AURORA WHOLESALERS, LLC, SOLON, OH:
2,968,390, CANC. INT. CL. 30.
- AUSTRALIAN GOLD, INC., INDIANAPOLIS, IN:
2,967,735, CANC. INT. CL. 3.
- AUSTRALIAN GOLD, LLC, INDIANAPOLIS, IN:
4,119,369, INT. CL. 3.
- AUTOMOTIVE RECYCLERS ASSOCIATION, MANASSAS,
VA, AKA ARA:
4,116,996, PUB. 1-10-2012. MULTIPLE CLASS, INT. CLS.
35 AND 42.
- AUVI TECHNOLOGIES LLC, SAINT CHARLES, MO:
2,967,844, CANC. INT. CL. 9.
- AVAILITY, L.L.C., JACKSONVILLE, FL:
2,667,172. REN. 2-22-12. INT. CL. 42.
- AVDEL UK LIMITED, HERTFORDSHIRE, UNITED KING-
DOM, AERPAT A.G., ZUG, SWITZERLAND:
1,673,186. REN. 2-23-12. INT. CL. 6.
- AVEDA CORPORATION, MINNEAPOLIS, MN:
4,119,481, INT. CL. 3.
- AVESTHAGEN INC., CHATSWORTH, CA:
2,967,545, CANC. INT. CL. 5.
- AVISOD LLC, PENSACOLA, FL:
4,118,690, PUB. 1-10-2012. INT. CL. 9.
- AVIVA PLC, LONDON, UNITED KINGDOM:
2,965,437, CANC. MULTIPLE CLASS, INT. CLS. 35, 36, 41
AND 42.
- AVNET, INC., PHOENIX, AZ:
1,700,991. REN. 2-22-12. INT. CL. 42.
- AVON PRODUCTS, INC., NEW YORK, NY:
2,968,178, CANC. INT. CL. 3.
- AVV WINERY CO., LLC, HEALDSBURG, CA:
4,117,131, PUB. 1-10-2012. INT. CL. 29.
- AWESOME KIDS, LLC, WHEATON, IL:
2,968,344, CANC. INT. CL. 16.
2,968,345, CANC. INT. CL. 28.
2,968,346, CANC. INT. CL. 41.
2,968,348, CANC. INT. CL. 3.
2,968,349, CANC. INT. CL. 9.
- AWESOME PRODUCTS, INC., BUENA PARK, CA:
4,119,701, INT. CL. 3.
4,119,702, INT. CL. 3.
- AWI ACQUISITION COMPANY, SYLMAR, CA, DBA AL-
LIED INTERNATIONAL:
2,547,657. REN. 2-22-12. MULTIPLE CLASS, INT. CLS. 8
AND 22.
- AWI ACQUISITION COMPANY, SYLMAR, CA, AWI AC-
QUISITION COMPANY, SYLMAR, CA:
2,548,345. REN. 2-22-12. INT. CL. 9.
- AWI ACQUISITION COMPANY, SYLMAR, CA:
4,116,585, PUB. 1-10-2012. MULTIPLE CLASS, INT. CLS.
8, 11 AND 16.
4,116,587, PUB. 1-10-2012. INT. CL. 8.
- AWSUM ENTERPRISES INC., PISCATAWAY, NJ, TA KAI-
ZEN MARTIAL ARTS:
4,118,904, INT. CL. 41.
- AXENS NORTH AMERICA INC, PRINCETON, NJ, HYDRO-
CARBON RESEARCH, INC., LAWRENCEVILLE, NJ:
1,191,361. REN. 2-22-12. MULTIPLE CLASS, INT. CLS. 37
AND 42.

AXIOMA OECONOMIA, LLC, BELLEAIR, FL:
4,119,760, INT. CL. 42.

AXLE TECH INTERNATIONAL IP HOLDINGS, LLC, TROY, MI, ROCKWELL INTERNATIONAL CORPORATION, PITTSBURGH, PA:
1,183,678, REN. 2-22-12, INT. CL. 12.

AYAM INC., FOREST HILLS, NY:
2,968,456, CANC. INT. CL. 25.

AYANDA AS, NORWAY:
4,116,692, PUB. 3-1-2011, MULTIPLE CLASS, INT. CLS. 5 AND 29.

AYOTTE, FRANCOIS, MONTREAL QC, CANADA:
4,119,579, INT. CL. 28.

A2SIX, INC., LISLE, IL:
4,119,324, INT. CL. 42.

B.A.S.S. (IP), LLC, BIRMINGHAM, AL:
2,549,098, REN. 2-21-12, INT. CL. 41.

B&B PROTECTOR PLANS, INC., TAMPA, FL:
4,118,193, PUB. 1-10-2012, INT. CL. 36.

BAA BAA ZUZU, INC., LAKE LEELANAU, MI:
4,117,706, PUB. 1-10-2012, MULTIPLE CLASS, INT. CLS. 18, 25 AND 26.

BABCOCK & WILCOX POWER GENERATION GROUP, INC., BARBERTON, OH:
4,117,257, PUB. 1-10-2012, INT. CL. 9.

BABYGARTEN MINNESOTA, LLC, ANOKA, MN:
4,117,509, PUB. 1-10-2012, INT. CL. 41.

BACHANI, SUHAIL, DUBAI, UNITED ARAB EMIR.:
4,117,718, PUB. 1-10-2012, INT. CL. 9.

BACHMAN COMPANY, THE, WYOMISSING, PA:
1,671,939, REN. 2-23-12, INT. CL. 30.

BACKCOUNTRY SOLUTIONS, LLC, TABERNASH, CO:
4,118,518, PUB. 1-10-2012, INT. CL. 9.

BAD LOVE COSMETICS COMPANY LLC, ARVADA, CO, DBA ELITE THERAPEUTICS:
4,118,376, PUB. 1-10-2012, INT. CL. 3.

BADBOB'S LLC, DYERSBURG, TN:
4,118,063, PUB. 1-10-2012, MULTIPLE CLASS, INT. CLS. 25 AND 30.

BAILEY, CAREY CLEMONS, PHOENIX, AZ:
4,119,448, INT. CL. 16.

BAISA, CHRIS, SAN FRANCISCO, CA:
2,468,446, CANC. INT. CL. 42.

BAKER CAPITAL LLC, MINNETONKA, MN:
2,535,919, REN. 2-22-12, INT. CL. 36.

BAKER HUGHES INCORPORATED, HOUSTON, TX:
4,117,219, PUB. 1-10-2012, INT. CL. 9.

BAKERY, CONFECTIONERY, TOBACCO WORKERS AND GRAIN MILLERS INTERNATIONAL UNION, KENSINGTON, MD:
2,543,972, REN. 2-23-12, INT. CL. 42.

BAKERYWORKS, L.L.C., DALLAS, TX:
4,118,512, PUB. 1-10-2012, INT. CL. 30.
4,118,514, PUB. 1-10-2012, INT. CL. 30.

BALAGIA, JAMIE, MANOR, TX:
4,118,720, PUB. 1-10-2012, INT. CL. 45.

BALCONES DISTILLING, LLC, WACO, TX:
4,117,904, PUB. 1-10-2012, INT. CL. 33.

BALDOTECH CORP, MIAMI, FL:
2,833,864, CANC. INT. CL. 33.

BALLY GAMING INTERNATIONAL, INC., LAS VEGAS, NV:
2,968,126, CANC. INT. CL. 9.

BALLYMORE PROPERTIES LIMITED, LONDON, UNITED KINGDOM:
4,116,594, PUB. 1-10-2012, MULTIPLE CLASS, INT. CLS. 19, 36, 37 AND 42.

BALT, INC., TEMPLE, TX:
2,967,898, CANC. INT. CL. 20.

BAMB ECOLOGICAL TECHNOLOGY, INC., METRO MANILA, PHILIPPINES:
4,117,805, PUB. 1-10-2012, INT. CL. 35.

BANANABEAT RECORDS, MALIBU, CA:
4,118,364, PUB. 1-10-2012, INT. CL. 25.

BANCO DAVIVIENDA, S.A., BOGOTA, COLOMBIA:
2,968,284, CANC. INT. CL. 36.

BANCTEC, INC., IRVING, TX:
1,183,583, REN. 2-20-12, INT. CL. 9.
1,183,583, CANC. INT. CL. 16.

BAND-IT-IDEX, INC., DENVER, CO:
4,119,602, INT. CL. 6.

BANK ADMINISTRATION INSTITUTE, CHICAGO, IL:
2,633,902, REN. 2-21-12, INT. CL. 41.

BANKCARD SERVICES, INC., FARMINGTON HILLS, MI:
4,118,124, PUB. 1-10-2012, INT. CL. 36.

BANKERS REALTY, TORRANCE, CA:
2,968,100, CANC. INT. CL. 36.

BAPTIST MEDICAL & DENTAL MISSION INTERNATIONAL, INC., HATTIESBURG, MS:
4,117,229, PUB. 1-10-2012, MULTIPLE CLASS, INT. CLS. 41, 43, 44 AND 45.

BARCLAYS BANK PLC, LONDON, UNITED KINGDOM:
4,117,451, PUB. 1-10-2012, INT. CL. 36.

BARCLAYS CAPITAL INC., NEW YORK, NY:
2,524,102, REN. 2-21-12, INT. CL. 36.

BAREFOOT BOTANICALS LIMITED, LONDON, N1 2LH, UNITED KINGDOM:
2,967,640, CANC. MULTIPLE CLASS, INT. CLS. 3 AND 5.

BARILLA G. E. R. FRATELLI - SOCIETA' PER AZIONI, PARMA, ITALY:
4,117,609, PUB. 1-10-2012, INT. CL. 30.

BARKMAN CONCRETE LTD., MANITOBA R0A 2A0, CANADA:
2,967,670, CANC. INT. CL. 28.

BARNES, JASON P., STUDIO CITY, CA, AKA JAZAN WILD:
4,117,262, PUB. 1-10-2012, MULTIPLE CLASS, INT. CLS. 9 AND 41.

BARNEY'S, INC., NEW YORK, NY:
2,552,600, REN. 2-19-12, INT. CL. 35.

BAROUDI, FRANK M, NAPLES, FL, DBA PURO UNO:
4,119,461, INT. CL. 33.

BARRENTINE, BARRY, ELKTON, MD:
2,968,248, CANC. INT. CL. 9.

BARRIE HOUSE COFFEE CO., INC., YONKERS, NY:
4,119,737, INT. CL. 30.

BARRON COUNTY CHEESE LLC, BARRON, WI:
4,117,556, PUB. 1-10-2012, INT. CL. 29.
4,119,534, INT. CL. 29.

BARRY CALLEBAUT AG, ZURICH, SWITZERLAND:
4,117,636, PUB. 1-10-2012, MULTIPLE CLASS, INT. CLS. 5, 29 AND 30.

BARTON NUTRITIONAL, MIAMI, FL:
4,119,171, INT. CL. 5.

BASF AGROCHEMICAL PRODUCTS B.V., ARNHEM, NETHERLANDS:
2,467,452, CANC. INT. CL. 5.

BASICNET SPA, ITALY:
4,116,706, PUB. 1-10-2012, MULTIPLE CLASS, INT. CLS. 3, 9, 18 AND 25.

BASISTA, JOSEPH J., DARTMOUTH, MA, DBA TOPHAT INTELLECTUAL PROPERTY CONSULTANTS:
4,117,870, PUB. 1-10-2012, INT. CL. 45.

BASMAN A. METTI, MORTON GROVE, IL:
4,118,954, INT. CL. 43.

BASS & HAYS FOUNDRY, INC., GRAND PRAIRIE, TX:
2,527,519, REN. 2-21-12, INT. CL. 6.

BASSLER, PATRICIA ROSANN, TRENTON, IL:
2,547,557, REN. 2-17-12, INT. CL. 25.

BATH & BODY WORK BRAND MANAGEMENT, INC., REYNOLDSBURG, OH:
2,621,534, REN. 2-21-12, MULTIPLE CLASS, INT. CLS. 3, 4 AND 5.
2,621,534, CANC. INT. CL. 11.

BATZ ENTERPRISES LLC, BLOOMINGTON, MN:
4,119,180, INT. CL. 41.

BAUERFEIND AG, ZEULENRODA, FED REP GERMANY:
4,116,885, PUB. 1-10-2012, MULTIPLE CLASS, INT. CLS. 9, 10, 25 AND 44.

BAUSCH & LOMB INCORPORATED, ROCHESTER, NY:
4,119,196, INT. CL. 10.

BAYARD, INC., NEW LONDON, CT:
4,117,478, PUB. 1-10-2012, INT. CL. 16.

- BAYER AKTIENGESELLSCHAFT, 51373 LEVERKUSEN, FED REP GERMANY:
1,182,937. REN. 2-21-12. INT. CL. 17.
- BAYER SAS, LYON, FRANCE:
2,967,406, CANC. INT. CL. 5.
- BAYER SCHERING PHARMA AKTIENGESELLSCHAFT, BERLIN, FED REP GERMANY:
2,965,612, CANC. INT. CL. 5.
2,965,613, CANC. INT. CL. 5.
2,965,890, CANC. INT. CL. 5.
2,965,894, CANC. INT. CL. 5.
- BAYERISCHE MOTOREN WERKE AKTIENGESELLSCHAFT, FED REP GERMANY:
4,116,745, PUB. 1-10-2012. INT. CL. 12.
- BAYLIS GENERATORS LIMITED, LONDON W15 2YZ, UNITED KINGDOM:
2,783,617, CANC. MULTIPLE CLASS, INT. CLS. 7, 8, 9, 11 AND 28.
- BAYLOR HEALTH CARE SYSTEM, DALLAS, TX:
3,039,590, COR. INT. CL. 44.
- BAYSHORE HISTORY, LLC, MARGATE, NJ:
4,119,670, INT. CL. 16.
- BAYVIEW ENTERTAINMENT, LLC, HACKENSACK, NJ:
4,119,143, MULTIPLE CLASS, INT. CLS. 9 AND 41.
- BBK TOBACCO & FOODS INC, PHOENIX, AZ, DBA HBI INTERNATIONAL:
2,467,118, CANC. INT. CL. 34.
- BCD-GMBH, FED REP GERMANY:
4,116,778, PUB. 1-10-2012. INT. CL. 9.
- BE FREE INC., WESTLAKE VILLAGE, CA:
2,467,112, CANC. MULTIPLE CLASS, INT. CLS. 9 AND 35.
- BEACH MOLD & TOOL, INC., NEW ALBANY, IN:
2,543,992. REN. 2-23-12. INT. CL. 40.
- BEACH TENNIS USA, LLC, FRANKLIN SQUARE, NY:
4,118,314, PUB. 1-10-2012. INT. CL. 28.
4,118,316, PUB. 1-10-2012. MULTIPLE CLASS, INT. CLS. 25 AND 41.
- BEAT BROKERS GLOBAL LLC, VACAVILLE, CA:
4,119,867, INT. CL. 35.
- BEATPORT, LLC, DENVER, CO:
4,119,425, MULTIPLE CLASS, INT. CLS. 9 AND 42.
- BEAULIEU GROUP, LLC, DALTON, GA:
4,119,388, INT. CL. 27.
- BECAUSE, INC., MERIDIAN, ID:
2,967,862, CANC. INT. CL. 21.
- BECKNER, AMANDA, PALM DESERT, CA:
2,547,298. REN. 2-21-12. INT. CL. 42.
- BECTON, DICKINSON AND COMPANY, FRANKLIN LAKES, NJ:
2,968,444, CANC. INT. CL. 9.
4,119,477, INT. CL. 10.
4,119,555, INT. CL. 42.
- BEEMAN, DAVID RODNEY, CAMARILLO, CA:
4,118,666, PUB. 1-10-2012. MULTIPLE CLASS, INT. CLS. 11 AND 32.
- BEIJING ACT ACADEMY OF SCIENCE & TECHNOLOGY APPLICATION, XICHENGQU, BEIJING, CHINA:
2,502,846. REN. 2-17-12. INT. CL. 5.
- BEL KAUKAUNA INC., KAUKAUNA, WI:
2,968,053, CANC. INT. CL. 29.
- BELCHER, MATTHEW J, CHICAGO, IL AND BELCHER LAW OFFICE, CHICAGO, IL:
4,116,930, PUB. 1-10-2012. INT. CL. 45.
- BELDEN INC., ST. LOUIS, MO:
1,189,845. REN. 2-17-12. INT. CL. 9.
- BELK STORES SERVICES, INC., CHARLOTTE, NC:
4,117,382, PUB. 1-10-2012. INT. CL. 35.
4,117,383, PUB. 1-10-2012. INT. CL. 35.
- BELKIN INTERNATIONAL, INC., COMPTON, CA:
4,118,979, INT. CL. 9.
- BELL, TWYANA, CHICAGO, IL, DBA T&T DEVELOPMENT:
2,967,730, CANC. INT. CL. 25.
- BELLA FOUR BAKERY, INC., CARSON CITY, NV:
4,119,643, INT. CL. 30.
- BELLEFLEUR, JUDY-ANN, BUTLER, PA, DBA J.B. WIGS:
4,118,067, PUB. 1-10-2012. INT. CL. 26.
- BELLISSIMO BRANDS, LLC, TAMPA, FL:
4,119,543, INT. CL. 25.
- BENCHMARK SENIOR LIVING, WELLESLEY, MA:
4,117,567, PUB. 1-10-2012. INT. CL. 42.
4,117,568, PUB. 1-10-2012. INT. CL. 42.
- BENJAMIN MEDIA, INC., PENINSULA, OH:
4,119,848, MULTIPLE CLASS, INT. CLS. 16 AND 41.
- BENZICK COMPANIES LLC, MINNEAPOLIS, MN:
2,968,243, CANC. INT. CL. 25.
- BERARDI, ROBERT, BREWSTER, NY:
2,467,977, CANC. INT. CL. 16.
- BEREAN CHRISTIAN STORES ENDEAVOR, LLC, WEST CHESTER, OH:
4,118,001, PUB. 1-10-2012. MULTIPLE CLASS, INT. CLS. 35 AND 36.
- BERMAN, ERICA LAYNE, ORLANDO, FL:
4,118,500, PUB. 1-10-2012. INT. CL. 41.
- BERNSTEIN, ANDREW, BROOKLYN, NY:
4,118,576, PUB. 1-10-2012. INT. CL. 41.
- BERTHELSEN, GEIR, KRISTIANSAND, NORWAY:
4,118,813, INT. CL. 32.
4,118,815, INT. CL. 32.
4,118,816, INT. CL. 32.
- BERTINO, WILLIAM, J., CHERRY HILL, NJ:
4,116,989, PUB. 1-10-2012. INT. CL. 5.
- BEST LANE ENTERPRISES, INC., BOCA RATON, FL:
4,117,690, PUB. 1-10-2012. INT. CL. 37.
- BEST MARKETING SERVICES, INC., LAS VEGAS, NV:
4,117,283, PUB. 1-10-2012. INT. CL. 29.
- BEST MOVIL C.A., LECHERIA, ANZOATEGUI, VENEZUELA:
4,117,050, PUB. 1-10-2012. INT. CL. 9.
- BETA THETA PI, OXFORD, OH, DBA BETA THETA PI FRATERNITY:
4,118,507, PUB. 1-10-2012. INT. CL. 35.
- BETHANY SCIENCES, L.L.C., NEW HAVEN, CT:
2,967,432, CANC. INT. CL. 41.
- BETHEL CHURCH OF REDDING, REDDING, CA:
4,117,090, PUB. 1-10-2012. MULTIPLE CLASS, INT. CLS. 9, 16, 25, 35, 41 AND 45.
- BETHESDA SOFTWARES LLC, ROCKVILLE, MD:
4,118,897, INT. CL. 9.
- BEVERLY HILLS ONCOLOGY MEDICAL GROUP, INC., BEVERLY HILLS, CA:
4,118,004, PUB. 1-10-2012. INT. CL. 44.
- BEYOND DENTAL & HEALTH, INC., STAFFORD, TX:
4,119,438, INT. CL. 3.
- BEYOND THE BEAUTY, NORTH HOLLYWOOD, CA:
4,119,559, INT. CL. 9.
- BH BRAND INC., NEW YORK, NY:
4,117,566, PUB. 1-10-2012. INT. CL. 25.
- BHP BILLITON S.A. LIMITED, RANBURG, SOUTH AFRICA:
4,116,670, PUB. 1-10-2012. MULTIPLE CLASS, INT. CLS. 1, 5 AND 40.
- BI-LO, LLC, GREENVILLE, SC:
1,529,949, CANC. INT. CL. 32.
- BIBICA CORPORATION, HO CHI MINH CITY, VIETNAM:
2,540,284. REN. 2-21-12. INT. CL. 30.
- BIDQWEST AVIATION, INC., GREELEY, CO:
2,968,641, CANC. INT. CL. 39.
- BIDWHAMMY, LLC, BUTLER, PA:
4,118,425, PUB. 1-10-2012. INT. CL. 35.
- BIELER & SCHNEIDER, LLC, NEW YORK, NY:
4,119,149, INT. CL. 40.
- BIELOMATIK LEUZE GMBH & CO., D-72639 NEUFFEN, FED REP GERMANY:
1,189,767. REN. 2-17-12. MULTIPLE CLASS, INT. CLS. 7 AND 9.
- BIG CITY ENTERTAINMENT, LLC, CHICAGO, IL:
4,118,497, PUB. 1-10-2012. MULTIPLE CLASS, INT. CLS. 25 AND 41.
- BIJA LAURENT, F-83170 VINS SUR CARAMY, FRANCE:
4,116,849, PUB. 1-10-2012. INT. CL. 14.
- BIJOUX TERNER, LLC, MIAMI, FL:
4,119,520, INT. CL. 14.
4,119,560, INT. CL. 14.

BIKINS BAR AND GRILL LLC, AUSTIN, TX:
4,117,905, PUB. 1-10-2012. INT. CL. 43.

BILAL, THURSTON R., LOS ANGELES, CA AND CLARK, JONATHAN, LOS ANGELES, CA:
2,467,368, CANC. INT. CL. 9.

BILLARD, CHARLES, SANDWICH, MA:
4,117,851, PUB. 1-10-2012. INT. CL. 35.

BILLERUD AB, SE-169 27 SOLNA, SWEDEN:
4,116,767, PUB. 1-10-2012. MULTIPLE CLASS, INT. CLS. 16, 39 AND 42.

BIOAMBER S.A.S., MONTREAL, QUEBEC, CANADA:
4,117,804, PUB. 1-10-2012. MULTIPLE CLASS, INT. CLS. 1 AND 45.
4,117,806, PUB. 1-10-2012. MULTIPLE CLASS, INT. CLS. 1 AND 45.
4,117,807, PUB. 1-10-2012. MULTIPLE CLASS, INT. CLS. 1 AND 45.

BIOINFORMATICS, LLC, ARLINGTON, VA:
2,649,616. REN. 2-23-12. INT. CL. 44.

BIOMET 3I, LLC, PALM BEACH GARDENS, FL:
4,117,992, PUB. 1-10-2012. INT. CL. 41.
4,117,993, PUB. 1-10-2012. INT. CL. 41.
4,117,994, PUB. 1-10-2012. INT. CL. 41.

BIOMET, INC., WARSAW, IN:
1,706,473. REN. 2-23-12. INT. CL. 10.

BIOTEST PUBLISHING COMPANY, INC., OXNARD, CA:
2,468,605, CANC. INT. CL. 16.

BIRDIE CO., LTD., TOKYO 150-0046, JAPAN:
2,967,896, CANC. INT. CL. 18.

BIRDSONG, W.E., FLORENCE, MS:
2,465,743, CANC. INT. CL. 2.

BIRDSTEP TECHNOLOGY AB, SOLNA, SWEDEN:
2,968,436, CANC. INT. CL. 9.

BIRKO ORTHOPAEDIE GMBH, 53545 LINZ, FED REP GERMANY:
2,966,150, CANC. INT. CL. 25.

BIRRA RONZANI S.R.L., SAN GIOVANNI IN PERSICETO (BOLOGNA), ITALY:
4,119,352, INT. CL. 32.

BIRTHDAYGIFT.COM, INC., WILTON, CT:
2,467,906, CANC. INT. CL. 35.

BIT THEORY, INC., COSTA MESA, CA:
4,118,700, PUB. 1-10-2012. INT. CL. 42.
4,118,707, PUB. 1-10-2012. INT. CL. 42.

BITMICRO NETWORKS, INC., FREMONT, CA:
2,526,194. REN. 2-22-12. INT. CL. 9.

BITWISE COMMUNICATIONS, INC., PEORIA, IL:
2,967,599, CANC. INT. CL. 38.

BIZ DEV GROUP, INC., PLEASANTON, CA:
4,117,224, PUB. 1-10-2012. INT. CL. 41.
4,117,246, PUB. 1-10-2012. INT. CL. 41.

SIZEQUITY, LLC, WILMINGTON, DE:
4,119,247, MULTIPLE CLASS, INT. CLS. 35, 36 AND 42.

BJ'S RESTAURANTS, INC., HUNTINGTON BEACH, CA:
4,118,678, PUB. 1-10-2012. INT. CL. 29.

BJORN BORG BRANDS AB, STOCKHOLM, SWEDEN:
2,518,900. REN. 2-17-12. MULTIPLE CLASS, INT. CLS. 3, 9, 18 AND 25.

BJ2, LLC, UNIVERSITY HEIGHTS, OH:
4,117,109, PUB. 1-10-2012. MULTIPLE CLASS, INT. CLS. 20 AND 24.

BLACK & BLACK SURGICAL, INC., TUCKER, GA:
4,118,388, PUB. 1-10-2012. INT. CL. 10.

BLACK, PATRICK, SHALIMAR, FL:
4,117,539, PUB. 1-10-2012. INT. CL. 35.

BLACKMORE, JORDAN, NEW YORK, NY:
4,119,595, INT. CL. 44.

BLACKRIDGE TECHNOLOGY HOLDINGS, INC., SANTA CLARA, CA:
4,116,573, PUB. 1-10-2012. MULTIPLE CLASS, INT. CLS. 9 AND 42.
4,116,574, PUB. 1-10-2012. MULTIPLE CLASS, INT. CLS. 9 AND 42.

BLACKSMITH BRANDS, INC., IRVINGTON, NY:
4,119,150, INT. CL. 3.

BLACKTREE ENTERPRISES, INC., UNION CITY, CA:
2,966,272, CANC. INT. CL. 9.

BLACKWOOD PROPERTIES, INC., LOS ANGELES, CA:
4,117,719, PUB. 1-10-2012. INT. CL. 36.

BLADE, ADRIAN, CASTLE ROCK, CO:
4,118,619, PUB. 1-10-2012. INT. CL. 9.

BLAEVOET, EDITH, SAINTE MAXIME, FRANCE:
4,117,844, PUB. 1-10-2012. INT. CL. 9.

BLANC AERO INDUSTRIES, F-75012 PARIS, FRANCE:
4,116,687, PUB. 1-10-2012. INT. CL. 6.
4,116,812, PUB. 1-10-2012. MULTIPLE CLASS, INT. CLS. 6, 7, 8, 9 AND 20.

BLANCHARD TRAINING AND DEVELOPMENT, INC., ESCONDIDO, CA:
1,668,478. REN. 2-17-12. INT. CL. 16.
1,668,479. REN. 2-17-12. INT. CL. 16.

BLANK GENERATION, LLC, SAN DIEGO, CA:
4,119,556, INT. CL. 25.

BLANKETBOOSTER, INC., PORTLAND, OR:
4,118,555, PUB. 1-10-2012. INT. CL. 20.
4,118,558, PUB. 1-10-2012. INT. CL. 20.
4,118,565, PUB. 1-10-2012. INT. CL. 20.

BLARNEY CASTLE OIL CO., BEAR LAKE, MI:
2,968,609, CANC. INT. CL. 35.

BLEVINS, LARRY W, WINTER PARK, FL, DBA MESOS, LLC:
4,119,499, INT. CL. 44.

BLIND SQUIRRELS PRODUCTION GROUP, INC., CINCINNATI, OH:
3,615,161, CANC. INT. CL. 41.

BLISSFUL WELLNESS MEDICAL WEIGHT LOSS CENTERS, LLC, JACKSONVILLE, FL:
4,118,670, PUB. 1-10-2012. MULTIPLE CLASS, INT. CLS. 35, 41 AND 44.
4,118,671, PUB. 1-10-2012. MULTIPLE CLASS, INT. CLS. 35, 41 AND 44.

BLISTT, LLC, STATE COLLEGE, PA:
4,119,561, INT. CL. 45.

BLUE CROSS & BLUE SHIELD OF MISSISSIPPI, A MUTUAL INSURANCE COMPANY, JACKSON, MS:
4,117,902, PUB. 1-10-2012. INT. CL. 36.

BLUE CROSS AND BLUE SHIELD ASSOCIATION, CHICAGO, IL:
2,544,950. REN. 2-21-12. MULTIPLE CLASS, INT. CLS. 36 AND 42.
2,544,951. REN. 2-21-12. MULTIPLE CLASS, INT. CLS. 36 AND 42.

BLUE EARTH LABS, LLC, LAS VEGAS, NV:
4,118,743, PUB. 1-10-2012. INT. CL. 1.

BLUE LEMON LLC, ALPINE, UT:
4,119,077, INT. CL. 43.

BLUE PLANET INTERNATIONAL, INC., LOS ANGELES, CA:
4,117,137, PUB. 1-10-2012. INT. CL. 25.

BLUE RIBBON IP, LLC, NEW YORK, NY:
4,119,223, INT. CL. 43.

BLUE SKY ARTIST MANAGEMENT, LLC., MINNEAPOLIS, MN:
2,466,919, CANC. INT. CL. 35.

BLUE STAR JETS, LLC, NEW YORK, NY:
4,119,633, INT. CL. 39.

BLUESTAR ENERGY SERVICES, INC., CHICAGO, IL:
4,117,321, PUB. 1-10-2012. INT. CL. 36.

BOARD OF TRUSTEES OF THE UNIVERSITY OF ARKANSAS, THE, LITTLE ROCK, AR:
1,666,147. REN. 2-21-12. INT. CL. 41.

BOB LEE ARCHERY, LP, JACKSONVILLE, TX:
4,117,037, PUB. 1-10-2012. INT. CL. 28.
4,117,038, PUB. 1-10-2012. INT. CL. 28.
4,117,041, PUB. 1-10-2012. INT. CL. 28.

BODEGA COOPERATIVA NUESTRA SEÑORA DE VALVANERA, SPAIN:
4,054,537, COR. INT. CL. 33.

BODEGA DANTE ROBINO S.A., BUENOS AIRES, ARGENTINA:
4,119,075, INT. CL. 33.

BODEGAS HACIENDA MONASTERIO, S.L., PESQUERA DE DUERO 47315, SPAIN:
2,966,163, CANC. INT. CL. 33.

- BODY INFUSION BY HER, LLC, WILMINGTON, MA:
4,119,414, INT. CL. 41.
- BOEHRINGER INGELHEIM INTERNATIONAL GMBH,
FED REP GERMANY:
4,116,831, PUB. 1-10-2012. MULTIPLE CLASS, INT. CLS.
41 AND 42.
4,116,832, PUB. 1-10-2012. MULTIPLE CLASS, INT. CLS.
41 AND 42.
4,116,833, PUB. 1-10-2012. MULTIPLE CLASS, INT. CLS.
41 AND 42.
4,116,834, PUB. 1-10-2012. MULTIPLE CLASS, INT. CLS.
41 AND 42.
4,116,835, PUB. 1-10-2012. MULTIPLE CLASS, INT. CLS.
41 AND 42.
4,116,836, PUB. 1-10-2012. MULTIPLE CLASS, INT. CLS.
41 AND 42.
4,116,837, PUB. 1-10-2012. MULTIPLE CLASS, INT. CLS.
41 AND 42.
4,116,838, PUB. 1-10-2012. MULTIPLE CLASS, INT. CLS.
41 AND 42.
- BOEHRINGER INGELHEIM INTERNATIONAL GMBH,
55218 INGELHEIM, FED REP GERMANY:
4,116,839, PUB. 1-10-2012. MULTIPLE CLASS, INT. CLS.
41 AND 42.
- BOEHRINGER INGELHEIM INTERNATIONAL GMBH,
FED REP GERMANY:
4,116,840, PUB. 1-10-2012. MULTIPLE CLASS, INT. CLS.
41 AND 42.
4,116,844, PUB. 1-10-2012. MULTIPLE CLASS, INT. CLS.
41 AND 42.
- BOEHRINGER INGELHEIM PHARMA GMBH & CO.
GMBH, 55218 INGELHEIM, FED REP GERMANY:
4,116,843, PUB. 1-10-2012. MULTIPLE CLASS, INT. CLS. 6
AND 39.
- BOEHRINGER INGELHEIM PHARMACEUTICALS, INC.,
RIDGEFIELD, CT:
4,119,004, MULTIPLE CLASS, INT. CLS. 14, 16, 25 AND
44.
4,119,007, MULTIPLE CLASS, INT. CLS. 16, 25, 28 AND
44.
4,119,008, MULTIPLE CLASS, INT. CLS. 16, 25, 28 AND
44.
4,119,009, MULTIPLE CLASS, INT. CLS. 16, 25, 28 AND
44.
- BOERDER, LARRY E., DALLAS, TX:
1,673,350. REN. 2-22-12. INT. CL. 9.
- BOHAGER HOLDINGS, LLC, PUNTA GORDA, FL:
4,118,457, PUB. 1-10-2012. INT. CL. 5.
- BOHATCH, ROMAN, GRAND RAPIDS, MI:
4,118,232, PUB. 1-10-2012. INT. CL. 30.
- BOINGY LLC, TIGARD, OR:
4,119,026, INT. CL. 22.
- BOLSTER LLC, DES PLAINES, IL:
4,117,319, PUB. 1-10-2012. INT. CL. 37.
4,117,320, PUB. 1-10-2012. INT. CL. 42.
- BOLTBLUE LIMITED, LONDON, ENGLAND, UNITED
KINGDOM:
2,968,000, CANC. INT. CL. 38.
- BOMAN, ROGER K., ORANGE COVE, CA, DBA BOMAN
PACKING:
2,967,956, CANC. INT. CL. 31.
- BOMBARDIER RECREATIONAL PRODUCTS INC., VAL-
COURT, QC, CANADA:
4,116,926, PUB. 8-9-2011. MULTIPLE CLASS, INT. CLS. 9,
12, 18, 25 AND 28.
4,116,927, PUB. 8-9-2011. MULTIPLE CLASS, INT. CLS. 9,
12, 18, 25 AND 28.
- BON VIEW TRADING 92 (PTY) LTD, STELLENBOSCH,
SOUTH AFRICA:
4,118,493, PUB. 1-10-2012. INT. CL. 33.
- BONGO LOGIC CO., LTD., BANGKOK 10500, THAILAND:
2,500,699. REN. 2-21-12. INT. CL. 15.
- BOOKSELLERS ENTERPRISES, LLC, LEXINGTON, KY:
4,117,877, PUB. 1-10-2012. INT. CL. 35.
4,117,918, PUB. 1-10-2012. INT. CL. 35.
- BOOZ ALLEN HAMILTON INC., MCLEAN, VA:
4,118,990, MULTIPLE CLASS, INT. CLS. 35 AND 45.
- BORICUA COLLECTION, L.L.C., TAMPA, FL:
2,968,129, CANC. MULTIPLE CLASS, INT. CLS. 25 AND
35.
- BOSCOV'S INVESTMENT COMPANY, INC., WILMINGTON,
DE:
4,118,018, PUB. 1-10-2012. INT. CL. 25.
- BOSS DISASTER RESTORATION, INC., MT. PLEASANT,
SC:
4,117,153, PUB. 1-10-2012. INT. CL. 37.
- BOSS MANUFACTURING COMPANY, KEWANEE, IL:
570,011. REN. 2-23-12. U.S. CL. 39 (INT. CL. 25).
- BOSSTRAP LLC, MARLBOROUGH, MA:
4,118,325, PUB. 1-10-2012. INT. CL. 9.
- BOSTON E LAB, INC., CANTON, MA:
4,117,492, PUB. 1-10-2012. INT. CL. 2.
- BOSTON FENCING CLUB, INC., WALTHAM, MA:
4,118,053, PUB. 1-10-2012. INT. CL. 41.
- BOSTON SCIENTIFIC NEUROMODULATION CORPORA-
TION, VALENCIA, CA:
4,119,063, INT. CL. 10.
- BOSTON SCOTT CORPORATION, WAKEFIELD, MA:
4,118,999, MULTIPLE CLASS, INT. CLS. 5 AND 10.
- BOTANICA FOODS, LLC, SAN FRANCISCO, CA:
2,467,261, CANC. INT. CL. 32.
- BOTHWELL, BRETT, NEW YORK, NY, DBA BOLT SPORTS
LLC:
4,118,943, INT. CL. 28.
- BOTICA COMERCIAL FARMACEUTICA LTDA., SAO JOSE
DOS PINHAIS, PARANA, BRAZIL:
2,967,482, CANC. INT. CL. 3.
- BOW BUDDIES, LLC, CHARLOTTE, NC:
4,117,982, PUB. 1-10-2012. INT. CL. 26.
- BOWERS, GINA M, WHEAT RIDGE, CO:
4,117,358, PUB. 1-10-2012. INT. CL. 5.
- BOWLE, MICHAEL LOUIS, GRESHAM, OR:
2,968,459, CANC. INT. CL. 25.
- BOWLER, WOSENNE, LAGUNA BEACH, CA:
4,119,456, INT. CL. 30.
- BOWLERZONE, LLC, GREENWOOD VILLAGE, CO:
4,119,516, INT. CL. 38.
- BOWMAN, WILLIAM E., ARLINGTON, MA:
2,466,843, CANC. INT. CL. 42.
- BOYCE & BEAN NATURAL GLASS & CLAY COMPANY,
INC., OCEANSIDE, CA:
2,468,588, CANC. INT. CL. 19.
- BOYCE, CRAIG, NAPLES, FL, DBA BAR BAZAAR:
4,118,432, PUB. 1-10-2012. INT. CL. 20.
- BP INTERNATIONAL RIGHTS HOLDINGS INC., RICH-
MOND, BRITISH COLUMBIA, CANADA:
2,968,494, CANC. INT. CL. 35.
2,968,495, CANC. INT. CL. 43.
- BPE, INC., EMPORIA, KS:
1,218,501. REN. 2-21-12. INT. CL. 28.
- BRAD PATTISON ENTERTAINMENT CORPORATION, KE-
LOWNA, BRITISH COLUMBIA:
4,116,602, PUB. 1-10-2012. MULTIPLE CLASS, INT. CLS.
9, 18, 20, 21, 25 AND 41.
- BRADLEY PRODUCTS INC., BLOOMINGTON, MN:
941,210. REN. 2-17-12. U.S. CL. 6 (INT. CL. 2).
- BRAINSTORMPRODUCTS, LLC., ESCONDIDO, CA:
4,117,497, PUB. 8-16-2011. INT. CL. 21.
- BRAINTREE PAYMENT SOLUTIONS, LLC, CHICAGO, IL:
4,118,177, PUB. 1-10-2012. INT. CL. 36.
- BRAINY BABY COMPANY, LLC, THE, ALPHARETTA,
UNITED STATES:
2,968,180, CANC. INT. CL. 35.
- BRAKE MASTERS SYSTEMS, INC., TUCSON, AZ:
2,614,011. REN. 2-21-12. INT. CL. 37.
- BRAKEBUSH BROTHERS, INC., WESTFIELD, WI:
1,736,835. REN. 2-17-12. INT. CL. 29.
- BRANDDECODE, SOCIÉTÉ PRIVÉE À RESPONSABILITÉ
LIMITÉE, BELGIUM:
4,116,801, PUB. 1-10-2012. MULTIPLE CLASS, INT. CLS.
9, 35 AND 41.
- BREEDLOVE, LYNN, SAN FRANCISCO, CA:
4,118,662, PUB. 1-10-2012. INT. CL. 39.
- BRELSFORD, OLIVER, COARSEGOLD, CA:
2,967,721, CANC. INT. CL. 9.

BRETT HICKEY, NEW YORK, NY:
4,119,129, INT. CL. 41.

BREVARD SOFTBALL MAGAZINE, INC., MERRITT ISLAND, FL:
4,117,312, PUB. 1-10-2012. INT. CL. 16.

BREWSTER, DANIEL M., ST. LOUIS, MO:
2,466,941, CANC. INT. CL. 41.

BRIAN LOVEGREN, BUCKEYE, AZ:
4,118,448, PUB. 1-10-2012. INT. CL. 41.

BRIDGESTONE BRANDS, LLC, NASHVILLE, TN:
4,118,863, INT. CL. 12.

BRIGGS MEDICAL SERVICE COMPANY, WEST DES MOINES, IA:
4,119,708, INT. CL. 9.

BRIGHTBILL, MICHAEL, G, WESTLAKE VILLAGE, CA:
4,119,600, INT. CL. 25.

BRIGHTWELL PAYMENTS, INC., ATLANTA, GA:
4,119,818, INT. CL. 9.

BRILLIANCE LED, LLC, CAREFREE, AZ:
4,119,858, INT. CL. 11.

BRISTOL WEST HOLDINGS, INC., DAVIE, FL:
2,967,924, CANC. MULTIPLE CLASS, INT. CLS. 36 AND 42.

BRITE-STRIKE TECHNOLOGIES INC., PLYMOUTH, MA:
4,117,969, PUB. 1-10-2012. INT. CL. 11.
4,117,971, PUB. 1-10-2012. INT. CL. 11.
4,118,302, PUB. 1-10-2012. INT. CL. 11.

BROADLEY-JAMES CORPORATION, IRVINE, CA:
4,117,014, PUB. 1-10-2012. INT. CL. 9.

BROCKMAN, LOUIS, LONG ISLAND CITY, NY:
4,118,901, INT. CL. 9.

BROKERAGE GROUP INTERNATIONAL, LLC, SPRINGFIELD, OH:
2,898,687, CANC. INT. CL. 36.

BROOKE J. SAUCIER, EVANSTON, IL:
4,118,317, PUB. 1-10-2012. INT. CL. 45.

BROOKLYN ON NORMAN INC., NEW YORK, NY:
4,119,851, INT. CL. 43.
4,119,852, INT. CL. 43.

BROOKS PRODUCTS, L.L.C., SALEM, NH:
2,967,897, CANC. INT. CL. 3.

BROOME INTERNATIONAL CONSORTIUM LLC, LOS ANGELES, CA:
4,118,230, PUB. 1-10-2012. INT. CL. 35.

BROUN, WAYNE H., WARRIEWOOD BEACH NSW, AUSTRALIA:
4,119,169, INT. CL. 14.

BROWN-FORMAN CORPORATION, LOUISVILLE, KY:
4,116,613, PUB. 1-10-2012. INT. CL. 30.

BROWNS CANYON CORPORATION, WILMINGTON, DE:
4,118,010, PUB. 1-10-2012. INT. CL. 35.

BRUGG ROHR AG, HOLDING, SWITZERLAND:
4,116,872, PUB. 1-10-2012. INT. CL. 6.

BRUNAS, RENATO, READING, PA, DBA OROMA:
2,467,375, CANC. INT. CL. 3.

BRUXIE, LLC, VILLA PARK, CA:
4,117,074, PUB. 1-10-2012. MULTIPLE CLASS, INT. CLS. 25, 30 AND 43.

BRYAN FAMILY ENTERPRISES LLC, UNION CITY, CA:
4,119,635, INT. CL. 9.

BRYER, MATTHEW D., GIBSONIA, PA, DBA POSTUREWELL:
4,116,570, PUB. 1-10-2012. INT. CL. 20.

BSK DEL PARTNERS, LLC, NEW YORK, NY:
4,117,897, PUB. 1-10-2012. INT. CL. 41.

BUCENELL, SUSAN B, WESLEY CHAPEL, FL:
4,023,556, COR. INT. CL. 5.

BUCK KNIVES, INC., EL CAJON, CA:
1,665,411, REN. 2-22-12. INT. CL. 8.

BUCKEYE TECHNOLOGIES INC., MEMPHIS, TN:
2,968,096, CANC. INT. CL. 16.

BUCKWOLD, BEN, WINNIPEG, MANITOBA, CANADA:
4,116,612, PUB. 1-10-2012. MULTIPLE CLASS, INT. CLS. 35, 38 AND 42.

BUDDY V ENTERTAINMENT, LLC, EAST HANOVER, NJ:
4,118,381, PUB. 1-10-2012. INT. CL. 35.

BUILDER'S BEST, INC., JACKSONVILLE, TX:
1,727,378, REN. 2-17-12. INT. CL. 11.

BULLEN COMPANIES, INC., THE, FOLCROFT, PA:
2,468,010, CANC. INT. CL. 3.

BULLETPROOF DESIGN LTD., LONDON, UNITED KINGDOM:
4,116,571, PUB. 10-4-2011. MULTIPLE CLASS, INT. CLS. 35 AND 42.
4,116,572, PUB. 10-4-2011. MULTIPLE CLASS, INT. CLS. 35 AND 42.

BUMBLE BEE FOODS, LLC, SAN DIEGO, CA:
4,118,369, PUB. 1-10-2012. INT. CL. 29.

BURBERRY LIMITED, LONDON SW1P 2AW, UNITED KINGDOM:
4,116,759, PUB. 1-10-2012. MULTIPLE CLASS, INT. CLS. 9, 14, 18, 25 AND 35.

BURGESS COMPUTER DECISIONS, INC., NORTHBROOK, IL:
4,117,622, PUB. 1-10-2012. MULTIPLE CLASS, INT. CLS. 9 AND 42.

BURKMANN INDUSTRIES, INC., DANVILLE, KY:
4,119,153, INT. CL. 31.

BURN SWITCH, FEASTERVILLE, PA:
4,118,447, PUB. 1-10-2012. INT. CL. 41.

BURSTYN, ADAM, MIAMI, FL:
4,119,591, INT. CL. 41.

BURT'S BEES, INC., DURHAM, NC:
4,119,800, INT. CL. 3.

BUSH INDUSTRIES, INC., JAMESTOWN, NY:
2,968,420, CANC. INT. CL. 20.

BUSH INTELLECTUAL PROPERTY LAW GROUP, LLC, BIRMINGHAM, AL:
4,118,194, PUB. 1-10-2012. INT. CL. 45.

BUSINESS CARDS TOMORROW, INC., FORT LAUDERDALE, FL:
2,514,835, REN. 2-22-12. INT. CL. 35.

BUSINESS JOURNALS, INC., NORWALK, CT:
2,967,411, CANC. INT. CL. 35.

BUSINESS OPPORTUNITY (BEIJING) NETWORK TECHNOLOGY CO., LTD, CHINA:
4,116,793, PUB. 1-10-2012. INT. CL. 42.

BUSKELL, WILLIAM, PANAMA CITY BEACH, FL:
4,119,508, INT. CL. 43.

BUTTERBALL, LLC, GARNER, NC:
2,670,148, CANC. INT. CL. 29.

BUUTEEQ, INC., SEATTLE, WA:
4,118,103, PUB. 1-10-2012. INT. CL. 42.

BUZZ BEE TOYS, INC., MT. LAUREL, NJ:
4,119,423, INT. CL. 28.

BUZZMEDIA, LOS ANGELES, CA:
4,116,591, PUB. 1-10-2012. INT. CL. 41.

BWX TECHNOLOGIES, INC., LYNCHBURG, VA:
2,968,108, CANC. INT. CL. 35.

BYL MANAGEMENT SERVICES, LLC, WEST CHESTER, PA:
2,468,524, CANC. INT. CL. 36.

BYRNE, ROBERT W., TORRANCE, CA:
3,050,864, CANC. INT. CL. 25.

B3 COMMUNICATIONS, LLC, CHICAGO, IL:
4,118,978, INT. CL. 38.

B3C FUEL SOLUTIONS, LLC, CINCINNATI, OH:
4,117,084, PUB. 1-10-2012. INT. CL. 1.
4,117,085, PUB. 1-10-2012. INT. CL. 1.

B4 VENTURES, L.L.C., LISBON, IA:
4,118,386, PUB. 1-10-2012. INT. CL. 5.
4,118,387, PUB. 1-10-2012. INT. CL. 3.

B4STUDENTS FOUNDATION, BALTIMORE, MD:
2,967,999, CANC. INT. CL. 41.

C SQUARED HOLDINGS LTD., LONDON, UNITED KINGDOM:
4,117,559, PUB. 1-10-2012. MULTIPLE CLASS, INT. CLS. 35 AND 41.

C. WONDER LLC, NEW YORK, NY:
4,119,727, INT. CL. 35.
4,119,735, INT. CL. 9.

C.B. FLEET INVESTMENT CORPORATION, WILMINGTON, DE:
2,967,439, CANC. INT. CL. 5.

- C.F.E.B. SISLEY, PARIS, FRANCE, CREATION FRANCAISE ESTHETIQUE BEAUTE (C.F.E.B.), PARIS, FRANCE, AKA SISLEY:
1,187,304. REN. 2-22-12. INT. CL. 3.
- C&L CREATIVE BOOKS LLC, BRUNSWICK, OH:
4,119,487, INT. CL. 16.
- C-KO SALES, LLC, MONROE, NY:
4,119,005, INT. CL. 38.
- C-TRAVEL INTERNATIONAL LIMITED, GEORGE TOWN, CAYMAN ISLANDS:
4,118,219, PUB. 1-10-2012. INT. CL. 43.
- CA ORGANIZATION, L.L.C., ORLANDO, FL, DBA CELEBRITY AUTO GROUP:
4,119,815, INT. CL. 35.
- CAADES SINALOA, A.C., COYOACAN, SINALOA 80000, MEXICO:
4,119,831, MULTIPLE CLASS, INT. CLS. 31 AND 35.
- CAANES, LLC, ALBEQUERQUE, NM:
4,119,571, INT. CL. 9.
- CABOT CORPORATION, BOSTON, MA:
4,119,506, INT. CL. 1.
- CABOTT, BARBARA, SANTA BARBARA, CA:
2,836,381, CANC. INT. CL. 41.
- CACTUS CORPORATION, JAPAN:
4,058,178, COR. MULTIPLE CLASS, INT. CLS. 3, 6, 9, 11, 18, 20, 21, 26 AND 28.
- CADENCE, INC., STAUNTON, VA:
4,116,974, PUB. 10-4-2011. MULTIPLE CLASS, INT. CLS. 9 AND 10.
- CADENZA MUSIC SÄRL, CH-1030 BUSSIGNY-LAUSANNE, SWITZERLAND:
4,116,751, PUB. 1-10-2012. MULTIPLE CLASS, INT. CLS. 9 AND 41.
- CADILLAC JACK, INC., DULUTH, GA:
4,119,551, INT. CL. 9.
4,119,817, INT. CL. 9.
- CAERBONT AUTOMOTIVE INSTRUMENTS LIMITED, SWANSEA, UNITED KINGDOM:
4,117,385, PUB. 1-10-2012. INT. CL. 9.
- CAESARS WORLD, INC., LAS VEGAS, NV:
3,178,188, AM. MULTIPLE CLASS, INT. CLS. 35, 36 AND 43.
- CAFEPRESS INC., SAN MATEO, CA:
4,117,639, PUB. 1-10-2012. MULTIPLE CLASS, INT. CLS. 35 AND 40.
- CAIL, MARY MCDANIEL, FREE UNION, VA:
4,118,934, MULTIPLE CLASS, INT. CLS. 9 AND 16.
- CAJA DE AHORROS Y MONTE DE PIEDAD DE NAVARRA, SPAIN:
4,116,693, PUB. 1-10-2012. INT. CL. 36.
- CAL-WEST SPECIALTY COATINGS, INC., SUNNYVALE, CA:
2,533,705. REN. 2-22-12. INT. CL. 2.
- CALEDONIA SPIRITS, INC., HARDWICK, VT:
4,119,837, INT. CL. 33.
- CALIFORNIA CAPITAL INSURANCE COMPANY, MONTEREY, CA, DBA CAPITAL INSURANCE GROUP:
4,118,640, PUB. 1-10-2012. INT. CL. 36.
- CALIFORNIA EXOTIC NOVELTIES, LLC, CHINO, CA:
4,117,205, PUB. 1-10-2012. INT. CL. 10.
- CALIFORNIA HI-LITES, INC., SANTA FE SPRINGS, CA:
1,662,614, CANC. INT. CL. 29.
- CALIFORNIA INSTITUTE OF TECHNOLOGY, PASADENA, CA:
1,675,826. REN. 2-21-12. INT. CL. 16.
- CALIFORNIA TAN, INC., LOS ANGELES, CA:
2,968,291, CANC. INT. CL. 3.
- CALOGERO HOLDINGS COMPANY, INC., CARLSBAD, CA:
4,119,250, INT. CL. 10.
- CALPIPE INDUSTRIES, DOWNEY, CA:
4,117,472, PUB. 1-10-2012. INT. CL. 40.
- CALSTONE COMPANY, SUNNYVALE, CA:
4,117,968, PUB. 1-10-2012. INT. CL. 19.
- CALVERT SCHOOL, BALTIMORE, MD:
4,119,340, INT. CL. 41.
- CALZATURIFICIO CASADEI S.P.A., 47030 SAN MAURO PASCOLI - FORLI, ITALY:
1,705,086. REN. 2-22-12. INT. CL. 25.
- CAMBRO MANUFACTURING COMPANY, HUNTINGTON BEACH, CA:
2,647,553. REN. 2-21-12. INT. CL. 21.
- CAMEO NOUVEAU, LLC, JERSEY CITY, NJ:
4,117,263, PUB. 1-10-2012. INT. CL. 35.
- CAMP COOLEY, LTD., FRANKLIN, TX:
2,468,145, CANC. MULTIPLE CLASS, INT. CLS. 5 AND 31.
- CAMPISI, RICHARD, M, SANTA ROSA BEACH, FL, DBA R. M. CAMPISI:
4,118,308, PUB. 1-10-2012. INT. CL. 25.
- CAMPUS CONCEPTS, INC., NEW YORK, NY:
1,684,425. REN. 2-22-12. INT. CL. 16.
- CANCERLINK ONTARIO INC., TORONTO, ONTARIO M3B 1Y8, CANADA:
4,118,752, MULTIPLE CLASS, INT. CLS. 16, 41 AND 44.
- CANDYLAND BRANDS LLC, WEST HOLLYWOOD, CA:
4,118,121, PUB. 1-10-2012. INT. CL. 30.
- CANNINGS, KELLY, KAMLOOPS, ALBERTA, CANADA:
2,968,015, CANC. INT. CL. 25.
- CAO, JIAN, GUANGZHOU, CHINA:
4,118,269, PUB. 1-10-2012. INT. CL. 25.
- CAPIENT INCORPORATED, LITTLE ROCK, AR:
2,530,017. REN. 2-22-12. INT. CL. 42.
- CAPITAL ONE FINANCIAL CORPORATION, GLEN ALLEN, VA:
2,968,347, CANC. INT. CL. 36.
- CAPITAL PERFORMANCE ADVISORS, LLC, WALNUT CREEK, CA:
2,467,231, CANC. INT. CL. 36.
- CAPITAS FINANCIAL, INC., MINNEAPOLIS, MN:
2,659,305. REN. 2-22-12. INT. CL. 36.
- CAPITO, CHARLES P., STEUBENVILLE, OH:
1,669,022. REN. 2-17-12. INT. CL. 42.
- CAPITOL ENVIRONMENTAL SERVICES, INC., VIENNA, VA:
2,968,003, CANC. INT. CL. 35.
- CAPRICO LLC, AVON, CO:
4,119,351, INT. CL. 25.
- CAPRILEE, LLC, WEST HOLLYWOOD, CA:
4,118,358, PUB. 1-10-2012. INT. CL. 44.
- CARDAGIN NETWORKS, INC., CHARLOTTESVILLE, VA:
4,118,016, PUB. 1-10-2012. INT. CL. 35.
- CARDIUM THERAPEUTICS, INC., SAN DIEGO, CA:
4,119,386, INT. CL. 5.
- CARDSMITH, LLC, BASKING RIDGE, NJ:
4,117,132, PUB. 1-10-2012. INT. CL. 36.
- CAREER INVESTMENT ADVISORS, INC., SAN DIEGO, CA:
4,118,057, PUB. 1-10-2012. INT. CL. 41.
- CAREERBUILDER, LLC, CHICAGO, IL:
4,119,338, MULTIPLE CLASS, INT. CLS. 35 AND 38.
- CAREERPHYSICIAN ADVISORS, LP, SOUTHLAKE, TX:
4,118,927, INT. CL. 41.
- CAREFUSION 2200, INC., SAN DIEGO, CA, AMERICAN HOSPITAL SUPPLY CORPORATION, EVANSTON, IL:
1,184,601. REN. 2-22-12. INT. CL. 10.
1,189,890. REN. 2-21-12. INT. CL. 10.
- CARENET PREGNANCY SERVICES OF DUPAGE COUNTY, INC., DOWNERS GROVE, IL:
4,117,336, PUB. 1-10-2012. INT. CL. 44.
- CARGILL, INCORPORATED, WAYZATA, MN:
1,668,722. REN. 2-17-12. INT. CL. 31.
- CARIGNAN, JOCELYNE, LA QUINTA, CA:
2,631,968. REN. 2-17-12. INT. CL. 12.
- CARIMAX CORPORATION, KYUNGGI-DO, REPUBLIC OF KOREA:
4,116,792, PUB. 1-10-2012. INT. CL. 18.
- CARL FREUDENBERG, WEINHEIM AN DER BERGSTRASSE, FED REP GERMANY:
1,192,552. REN. 2-22-12. MULTIPLE CLASS, INT. CLS. 22, 23 AND 24.
- CARLETON, PAUL DEHN, PONTIAC, MI:
2,968,634, CANC. INT. CL. 16.
- CARLSON MORGAN LLC, MODESTO, CA:
4,118,509, PUB. 1-10-2012. INT. CL. 31.

CARLSON, JAMES, DR., WOODINVILLE, WA, DBA ACCU-LINER PRODUCTS:
2,467,133, CANC. INT. CL. 10.

CARMICHAEL, STACY, LAGUNA NIGUEL, CA, CONONE, GLENN, MURRIETA, CA:
1,669,536, REN. 2-22-12. INT. CL. 25.

CARNABY HOME, LLC, CINCINNATI, OH:
4,117,671, PUB. 1-10-2012. INT. CL. 35.

CARNEVALE, JAMES, ALBUQUERQUE, NM:
2,968,566, CANC. INT. CL. 44.

CAROL ANN MARKETING, INC., WEST CHICAGO, IL:
4,118,186, PUB. 1-10-2012. INT. CL. 35.

CAROLINA SKIFF, LLC, WAYCROSS, GA:
4,118,564, PUB. 1-10-2012. INT. CL. 12.

CAROLINA WATERWORKS, INC., MT. PLEASANT, SC:
2,967,693, CANC. INT. CL. 6.

CAROLLO ENGINEERS, INC., FOUNTAIN VALLEY, CA:
4,116,621, PUB. 1-10-2012. INT. CL. 42.

CARR, STEPHANIE Y, DETROIT, MI, DBA MIND, BELLY & SOUL:
4,116,953, PUB. 1-10-2012. INT. CL. 41.

CARROLL HALL SHELBY TRUST, LOS ANGELES, CA:
4,118,294, PUB. 1-10-2012. MULTIPLE CLASS, INT. CLS. 3, 6, 9, 11, 12, 20, 24 AND 26.
4,118,301, PUB. 1-10-2012. MULTIPLE CLASS, INT. CLS. 20, 21 AND 28.

CARTER BRUCE LLC, AUSTIN, TX:
4,118,023, PUB. 1-10-2012. INT. CL. 37.

CARTER, MERCEDES LYNN ANTIONETTE, LAS VEGAS, NV:
4,118,791, INT. CL. 9.

CARTER, R. KENNETH, CASTLE ROCK, CO, DBA MOON-DAWG INDUSTRIES:
2,967,907, CANC. INT. CL. 21.

CARTWHEELS, INC., GRAND LEDGE, MI:
2,977,021, CANC. INT. CL. 28.

CARTWRIGHT, TERESA J. "TESS", LAHAINA, HI, DBA MEWE CREATIONS:
2,078,947, CANC. INT. CL. 41.

CARUS PUBLISHING COMPANY, CHICAGO, IL:
2,527,251, REN. 2-21-12. INT. CL. 16.

CARVAJAL S.A., BOGOTA D.C., COLOMBIA:
2,467,365, CANC. INT. CL. 16.

CASA GRANDE INTERACTIVE COMMUNICATIONS, INC., SAN JUAN, PUERTO RICO:
4,117,628, PUB. 1-10-2012. INT. CL. 9.

CASABELLA HOLDINGS, L.L.C., BLAUVELT, NY:
2,967,960, CANC. INT. CL. 21.

CASCADE DESIGNS, INC., SEATTLE, WA:
2,967,337, CANC. MULTIPLE CLASS, INT. CLS. 11 AND 21.

CASCO BAY GARDENS, LLC., SOUTH PORTLAND, ME:
2,982,227, COR. INT. CL. 3.

CASE ENGINEERING, LLC, EVANSVILLE, IN, DBA CASE CONTROLS:
4,117,488, PUB. 1-10-2012. INT. CL. 9.

CASH MONEY RECORDS, INC., NEW YORK, NY:
2,524,017, REN. 2-21-12. MULTIPLE CLASS, INT. CLS. 35 AND 41.

CASTLE MEDIA GROUP, INC., TEMPE, AZ:
4,117,833, PUB. 1-10-2012. MULTIPLE CLASS, INT. CLS. 35 AND 41.

CASTRO, JUAN MANUEL, APPLE VALLEY, CA, DBA MEXICO LINDO & SEAFOOD RESTAURANT:
4,118,083, PUB. 1-10-2012. INT. CL. 43.

CATE, SUMMER R., REDDING, CA:
2,968,477, CANC. INT. CL. 35.

CATHERINE ANGIEL'S GALLERY ECLECTIC, INC., NEW YORK, NY:
2,467,864, CANC. INT. CL. 35.

CATHOLIC MIGRATION SERVICES OF QUEENS, INC., ELMHURST, NY:
2,907,872, CANC. INT. CL. 42.

CATON, RICHARD, LANCASTER, CA:
4,118,586, PUB. 1-10-2012. INT. CL. 36.

CAWA INDUSTRIAL CO., LTD., CHEUNG SHA WAN, HONG KONG:
4,117,952, PUB. 1-10-2012. INT. CL. 9.

CAWTHON, MARTIN R., DEARBORN, MI, DBA CAWTHON SOFTWARE GROUP:
1,741,025, REN. 2-22-12. INT. CL. 9.

CAZET, ROBERT, SANTA ROSA, CA:
4,117,134, PUB. 1-10-2012. INT. CL. 41.

CBI INTERNATIONAL, LLC, HIALEAH, FL:
4,119,473, INT. CL. 29.

CC INVESTMENTS LLC, GRAND JUNCTION, CO:
4,119,610, INT. CL. 43.

CCH INCORPORATED, RIVERWOODS, IL:
2,536,426, REN. 2-22-12. INT. CL. 9.
2,536,427, REN. 2-22-12. INT. CL. 9.
2,536,428, REN. 2-22-12. INT. CL. 9.

CDOC, INC., CARMEL, IN:
2,467,109, CANC. INT. CL. 16.
4,119,444, INT. CL. 36.

CDW LLC, VERNON HILLS, IL:
2,527,422, REN. 2-22-12. INT. CL. 35.

CEDAR CREST VILLAGE, INC., BALTIMORE, MD, ERICKSON RETIREMENT COMMUNITIES, LLC, BALTIMORE, MD:
2,547,793, REN. 2-21-12. INT. CL. 42.

CELEBRATION GIFT BASKETS, INC., BELLEVUE, WA:
2,562,820, REN. 2-23-12. INT. CL. 42.

CELERA CORPORATION, ALAMEDA, CA:
2,520,852, REN. 2-22-12. INT. CL. 9.

CELES KING III AND ASSOCIATES, LOS ANGELES, CA:
2,879,372, CANC. INT. CL. 36.
2,899,593, CANC. INT. CL. 36.

CELESTIAL SEASONING, INC, BOULDER, CO:
1,152,587, CANC. INT. CL. 30.

CELL SIGNALING TECHNOLOGY, INC., DANVERS, MA:
4,119,795, INT. CL. 1.

CELLGUARD, INC., TOMS RIVER, NJ:
4,117,576, PUB. 10-4-2011. INT. CL. 36.

CELLULAR BIOENGINEERING, INC., HONOLULU, HI:
4,118,914, INT. CL. 9.

CEM & ASSOCIATES, BOULDER, CO, DBA PICOSPIN:
4,119,241, INT. CL. 9.

CENTENE CORPORATION, ST. LOUIS, MO:
4,119,384, INT. CL. 42.

CENTER FOR DIAGNOSTIC IMAGING, INC., ST. LOUIS PARK, MN:
4,118,688, PUB. 1-10-2012. INT. CL. 44.

CENTRAL CHRISTIAN CHURCH, HENDERSON, NV:
4,117,962, PUB. 1-10-2012. INT. CL. 45.

CENTRAL DE MASSAS PASTELANDIA LTDA., 4070-0 SAO PAULO -SP, BRAZIL:
2,467,693, CANC. INT. CL. 42.

CENTRAL FLORIDA UROLOGY SPECIALISTS, LLC, OXFORD, FL:
4,117,296, PUB. 1-10-2012. INT. CL. 44.
4,117,297, PUB. 1-10-2012. INT. CL. 44.

CENTURY FURNITURE LLC, HICKORY, NC:
1,701,823, REN. 2-21-12. INT. CL. 20.

CERTAINTED PACIFIC WINDOWS CORPORATION, VALLEY FORGE, PA:
2,968,273, CANC. INT. CL. 19.

CERTIFIED CAJUN, INC., BUNKIE, LA:
4,119,790, INT. CL. 25.

CFC, INC., CHICAGO, IL:
2,468,012, CANC. INT. CL. 4.

CFM CONSOLIDATED, INC., FIFE, WA:
4,117,828, PUB. 1-10-2012. INT. CL. 1.

CHALLENGE AMERICA, DENVER, CO:
4,116,955, PUB. 1-10-2012. INT. CL. 35.

CHALLENGER & TRUSS PRODUCTIONS, PELHAM, AL:
4,118,049, PUB. 1-10-2012. INT. CL. 35.

CHAMBERLAIN DISTRIBUTING, NOGALES, AZ:
2,533,147, REN. 2-22-12. INT. CL. 31.

CHAMELEON SOFTWARE, INC., ST. LOUIS, MO:
4,117,595, PUB. 1-10-2012. MULTIPLE CLASS, INT. CLS. 9 AND 42.

CHAMPION WINDOW MANUFACTURING AND SUPPLY CO., LLC, CINCINNATI, OH:
4,117,867, PUB. 1-10-2012. INT. CL. 37.

- CHAMPIONSHIP AUTO SHOWS, INC., AUBURN HILLS, MI, PROMOTIONS, INC., PONTIAC, MI:
1,703,851. REN. 2-17-12. INT. CL. 41.
- CHAN ENTERPRISES, INC., REDONDO BEACH, CA:
4,118,810, INT. CL. 5.
- CHAN, LISA, DALY CITY, CA:
4,118,040, PUB. 1-10-2012. INT. CL. 36.
- CHANEL, INC., NEW YORK, NY:
2,967,506, CANC. INT. CL. 3.
- CHAPCO PRODUCTS INC, MIDLOTHIAN, TX:
4,119,601, INT. CL. 28.
- CHAPMAN THERMAL PRODUCTS, INC., SALT LAKE CITY, UT:
2,541,122. REN. 2-23-12. INT. CL. 24.
- CHARITY AND PRUDENCE, LLC, PROVO, UT, AKA GURU'S:
4,117,603, PUB. 1-10-2012. INT. CL. 43.
- CHARLES INDUSTRIES, LTD., ROLLING MEADOWS, IL:
1,183,788. REN. 2-22-12. INT. CL. 20.
- CHARLES SCHWAB & CO., INC., SAN FRANCISCO, CA:
2,530,501. REN. 2-23-12. INT. CL. 36.
2,967,316, CANC. INT. CL. 36.
4,117,493, PUB. 1-10-2012. INT. CL. 36.
4,118,065, PUB. 1-10-2012. INT. CL. 36.
- CHARLOTTE D SUMRALL, BATON ROUGE, LA, DBA WELCOME HOST:
4,117,517, PUB. 1-10-2012. INT. CL. 35.
- CHARTPAK, INC., MELVILLE, NY, M. GRUMBACHER, INC., NEW YORK, NY:
1,184,354. REN. 2-22-12. INT. CL. 2.
- CHARTRAND, BRIAN, NASHVILLE, TN AND PRICE, RICH, NASHVILLE, TN AND NAUGHTON, GREG, NASHVILLE, TN:
4,117,089, PUB. 1-10-2012. INT. CL. 9.
- CHASE MEDICAL COMMUNICATIONS, INC., WILTON, CT:
4,118,766, INT. CL. 16.
- CHATURVEDI, DR. ANOOP, SUGAR LAND, TX:
4,119,788, INT. CL. 38.
- CHEAPCARIBBEAN.COM, INC., DOYLESTOWN, PA:
4,118,796, MULTIPLE CLASS, INT. CLS. 39, 41 AND 43.
- CHECKS IN THE MAIL, INC., NEW BRAUNFELS, TX:
4,119,275, MULTIPLE CLASS, INT. CLS. 16, 18 AND 21.
4,119,276, MULTIPLE CLASS, INT. CLS. 16, 18 AND 21.
4,119,277, MULTIPLE CLASS, INT. CLS. 16, 18 AND 21.
- CHELSEA BABY, LLC, MINNEAPOLIS, MN:
4,118,190, PUB. 1-10-2012. MULTIPLE CLASS, INT. CLS. 25 AND 26.
- CHELSEA INDUSTRIES, INC., PEABODY, MA, DBA WEBSTER INDUSTRIES:
2,968,081, CANC. INT. CL. 16.
- CHEM MAX CORPORATION, NORTON SHORES, MI:
1,721,286. REN. 2-22-12. INT. CL. 3.
- CHEMINOVA A/S, DENMARK:
2,967,223.
- CHEMSPEC USA, INC., ORRVILLE, OH:
4,119,684, INT. CL. 2.
- CHENOK, GRANT P, SAN JOSE, CA AND DRAGO, NICHOLAS D, SAN JOSE, CA:
4,117,421, PUB. 1-10-2012. MULTIPLE CLASS, INT. CLS. 9 AND 41.
- CHERI L. SIMMONS, SACRAMENTO, CA:
4,118,838, MULTIPLE CLASS, INT. CLS. 41, 44 AND 45.
- CHESLEY R. HOUSKE, JR., DDS, INC., SANTA BARBARA, CA:
4,118,800, INT. CL. 30.
- CHET ZELASKO PHD, LLC, GRAND RAPIDS, MI:
4,118,827, INT. CL. 41.
- CHEVRON INTELLECTUAL PROPERTY LLC, SAN RAMON, CA:
2,968,188, CANC. INT. CL. 42.
2,968,189, CANC. INT. CL. 42.
- CHG MANAGEMENT, INC., SALT LAKE CITY, UT:
4,119,410, INT. CL. 35.
- CHICKEN FAT ENTERPRISES, INC., ABERDEEN, NJ:
2,467,511, CANC. INT. CL. 9.
- CHIESI FARMACEUTICI S.P.A., 43122 PARMA, ITALY:
4,118,407, PUB. 1-10-2012. INT. CL. 5.
4,118,408, PUB. 1-10-2012. INT. CL. 5.
4,118,409, PUB. 1-10-2012. INT. CL. 5.
4,118,410, PUB. 1-10-2012. INT. CL. 5.
4,118,411, PUB. 1-10-2012. INT. CL. 5.
- CHILDREN HELPING CHILDREN, INC., ATLANTA, GA:
4,117,893, PUB. 1-10-2012. INT. CL. 35.
- CHIROPRACTIC CARE OF MINNESOTA, INC., SHOREVIEW, MN:
4,119,251, INT. CL. 44.
- CHOI, TAE YI, ARCADIA, CA:
4,119,462, INT. CL. 25.
- CHONGQING YINXIANG XIAOXING GENERAL MACHINERY CO., LTD., CHONGQING, CHINA:
4,118,645, PUB. 1-10-2012. INT. CL. 7.
4,118,649, PUB. 1-10-2012. INT. CL. 7.
- CHRISTIAN COPYRIGHT LICENSING INTERNATIONAL, INC., PORTLAND, OR:
4,118,187, PUB. 1-10-2012. INT. CL. 41.
- CHRISTIANBOOK.COM, LLC, PEABODY, MA:
2,639,594. REN. 2-22-12. MULTIPLE CLASS, INT. CLS. 35, 41 AND 42.
- CHRISTIE DIGITAL SYSTEMS USA, INC., CYPRESS, CA, CHRISTIE ELECTRIC CORP., TORRANCE, CA:
1,184,565. REN. 2-22-12. INT. CL. 9.
- CHRISTINE VALENZA, HACKENSACK, NJ:
4,119,216, INT. CL. 5.
- CHRISTOPHER GREAVES, UNIONDALE, NY:
4,118,443, PUB. 1-10-2012. INT. CL. 25.
- CHRISTOPHER KINGSLEY, OXFORD OXFORDSHIRE, UNITED KINGDOM AND JASON KINGSLEY, OXFORD OXFORDSHIRE, UNITED KINGDOM:
4,117,363, PUB. 1-10-2012. MULTIPLE CLASS, INT. CLS. 9, 16, 28 AND 41.
- CHRISTOPHER PFEFFERKORN, BOULDER, CO:
4,117,862, PUB. 1-10-2012. INT. CL. 41.
- CHRISTOPHER WRAY, CARLSBAD, CA:
4,119,301, INT. CL. 16.
- CHROMALLOY GAS TURBINE LLC, ORANGETOWN, NY:
2,563,399. REN. 2-22-12. INT. CL. 7.
- CHROME HEARTS, LLC, HOLLYWOOD, CA:
2,538,565. REN. 2-21-12. INT. CL. 9.
- CHRYSLER GROUP LLC, AUBURN HILLS, MI:
2,587,818. REN. 2-21-12. INT. CL. 16.
- CHUANG PAY INTERNATIONAL CO., LTD., TAIPEI CITY 10044, TAIWAN:
4,117,831, PUB. 11-29-2011. INT. CL. 30.
- CHUKA, CLARK, CORONA DEL MAR, CA:
1,669,777. REN. 2-21-12. INT. CL. 41.
- CHUMS, INC., SALT LAKE CITY, UT, DBA CHUMS-CHISCO:
2,467,794, CANC. INT. CL. 9.
- CHUNG & ASSOCIATES, LLC, LOS ANGELES, CA, DBA CASHMERE AGENCY:
4,118,548, PUB. 1-10-2012. INT. CL. 41.
- CHURCH & DWIGHT CO., INC., PRINCETON, NJ:
4,119,569, INT. CL. 31.
- CHURCHILL COATINGS CORPORATION:
2,533,624, CANC. INT. CL. 2.
- CHURCHILL DOWNS INCORPORATED, LOUISVILLE, KY:
4,117,242, PUB. 1-10-2012. INT. CL. 41.
- CIAMPA, JOHN A., CORAL GABLES, FL, DBA ALTA SYSTEMS:
4,117,621, PUB. 1-10-2012. MULTIPLE CLASS, INT. CLS. 12 AND 41.
- CIBA SPECIALTY CHEMICALS CORPORATION, TARRYTOWN, NY:
2,466,953, CANC. INT. CL. 1.
- CID RESOURCES, INC., DALLAS, TX:
4,118,414, PUB. 1-10-2012. INT. CL. 10.
- CIGARS INTERNATIONAL, INC., BETHLEHEM, PA:
4,116,596, PUB. 1-10-2012. MULTIPLE CLASS, INT. CLS. 34 AND 35.
- CIMARRON LUMBER AND SUPPLY COMPANY, KANSAS CITY, MO:
2,501,549. REN. 2-17-12. INT. CL. 35.

CINCINNATI REDS, LLC, THE, CINCINNATI, OH:
2,536,081. REN. 2-22-12. INT. CL. 25.

CINEDIGM DIGITAL CINEMA CORP., MORRISTOWN, NJ:
4,118,439. PUB. 1-10-2012. INT. CL. 9.

CINEMA GRILL SYSTEMS, INC., ATLANTA, GA:
2,467,183. CANC. MULTIPLE CLASS, INT. CLS. 41 AND 42.

CINEVEGAS, LLC, HENDERSON, NV:
2,467,611. CANC. INT. CL. 41.

CINTAS HOLDINGS LLC, MASON, OH:
2,542,678. REN. 2-21-12. INT. CL. 9.

CIPEX INTERNATIONAL LIMITED, SANTA FE SPRINGS, CA:
4,119,376. INT. CL. 19.

CISCO TECHNOLOGY, INC., SAN JOSE, CA:
4,119,172. INT. CL. 9.
4,119,184. MULTIPLE CLASS, INT. CLS. 35 AND 36.

CITITURF, LLC, MURPHY, TX:
4,117,959. PUB. 1-10-2012. MULTIPLE CLASS, INT. CLS. 37 AND 44.

CITIZENLINK, COLORADO SPRINGS, CO:
4,118,146. PUB. 1-10-2012. INT. CL. 16.

CITRA SOLV, LLC, RIDGEFIELD, CT:
4,119,128. INT. CL. 3.

CITRA-SOLV LLC, RIDGEFIELD, CT, CITRA-SOLV LLC, RIDGEFIELD, CT:
2,531,417. REN. 2-23-12. INT. CL. 3.

CITY AND COUNTY OF SAN FRANCISCO, SAN FRANCISCO, CA:
4,119,887. INT. CL. 36.

CITY ELECTRIC SUPPLY CO., ORLANDO, FL:
4,118,111. PUB. 1-10-2012. INT. CL. 11.

CITY MEDICAL OF UPPER EAST SIDE, PLLC, NEW YORK, NY:
4,117,854. PUB. 1-10-2012. INT. CL. 44.

CITY NATIONAL BANK, BEVERLY HILLS, CA:
4,119,808. INT. CL. 36.

CITY OF CLOVIS, CLOVIS, CA:
2,468,403. CANC. INT. CL. 42.

CITY OF MURPHY, TEXAS, MURPHY, TX:
4,117,471. PUB. 1-10-2012. INT. CL. 35.

CITY SMOKE HOUSE, MORAGA, CA:
4,117,997. PUB. 1-10-2012. INT. CL. 43.

CITYSTASH HOLDINGS, LLC, ARLINGTON, VA:
4,119,170. INT. CL. 39.
4,119,227. INT. CL. 39.
4,119,228. INT. CL. 39.

CIXING GROUP CO., LTD., CI XI, ZHEJIANG, CHINA:
1,676,578. REN. 2-22-12. INT. CL. 7.

CJ OMNI, INC., SOUTH GATE, CA, ANNIE CHUN'S INC., SAN RAFAEL, CA:
2,623,868. REN. 2-21-12. INT. CL. 30.

CJ PRODUCTS, LLC, OCEANSIDE, CA:
4,119,253. INT. CL. 28.

CL FREE WATER SYSTEMS, LLC, SCOTTSDALE, AZ:
4,117,792. PUB. 1-10-2012. INT. CL. 11.

CLAIRE VIDAL, FRANCE:
4,116,689. PUB. 1-10-2012. INT. CL. 37.

CLARENCE J. VENNE, L.L.C., BRISTOL, PA, CLARENCE J. VENNE, L.L.C., BRISTOL, PA:
2,606,164. REN. 2-21-12. INT. CL. 16.

CLARIANT AG, SWITZERLAND:
2,967,222.

CLARIANT GMBH, SULZBACH, FED REP GERMANY, HOECHST AKTIENGESELLSCHAFT, AM MAIN, FED REP GERMANY:
1,669,057. REN. 2-17-12. INT. CL. 1.

CLARINS FRAGRANCE GROUP, F-92200 NEUILLY SUR SEINE, FRANCE:
4,116,846. PUB. 1-10-2012. INT. CL. 3.

CLARISSE CLEMONS-FERRARA, MD, PAWCATUCK, CT:
4,118,363. PUB. 1-10-2012. INT. CL. 44.

CLARKE, TREVOR S., SAN DIEGO, CA:
4,118,657. PUB. 1-10-2012. INT. CL. 25.

CLASSIC MEDIA, LLC, NEW YORK, NY:
2,967,413. CANC. INT. CL. 28.

CLAUDIU CO., LTD., SHIBUYA-KU, TOKYO, JAPAN:
4,118,938. INT. CL. 25.

CLAUS, JOHN P., SAN JOSE, CA:
4,119,198. INT. CL. 43.

CLAY BAKER, PORTOLA VALLEY, CA, DBA WEST280 AND THOMAS RAMIES, PORTOLA VALLEY, CA, DBA WEST280:
4,119,442. INT. CL. 9.

CLAY SOUP, INC., SLATE HILL, NY:
2,967,851. CANC. MULTIPLE CLASS, INT. CLS. 16 AND 25.

CLEANING POLICE LLC, EXETER, NH:
4,117,896. PUB. 1-10-2012. INT. CL. 37.

CLEAR CHANNEL IDENTITY, L.P., CLAYMONT, DE:
2,967,981. CANC. MULTIPLE CLASS, INT. CLS. 25 AND 35.

CLEAR PASSAGE THERAPIES, INC., GAINESVILLE, FL:
2,468,161. CANC. INT. CL. 42.

CLEARVISTA, LLC, QUEEN CREEK, AZ:
4,118,400. PUB. 1-10-2012. INT. CL. 45.

CLEELAND, CAMERON, MOUNT VERNON, WA:
4,118,003. PUB. 1-10-2012. INT. CL. 36.

CLEMENT COMMUNICATIONS, INCORPORATED, CONCORDVILLE, PA:
2,467,798. CANC. INT. CL. 16.

CLERICUZIO, FRANK D., METUCHEN, NJ:
1,691,865. REN. 2-22-12. INT. CL. 35.

CLEVELAND STATE UNIVERSITY, CLEVELAND, OH:
4,118,856. MULTIPLE CLASS, INT. CLS. 6, 16, 18, 21, 24 AND 25.

CLINE, JAMES, HICKORY, NC:
1,674,992. REN. 2-21-12. INT. CL. 14.

CLINICAL INK, INC., WINSTON-SALEM, NC:
4,118,890. INT. CL. 9.

CLOCKWORK IP, LLC, SARASOTA, FL:
4,118,017. PUB. 1-10-2012. INT. CL. 37.
4,118,675. PUB. 1-10-2012. INT. CL. 35.

CLOSET BABY, LLC, HIGGINSVILLE, MO:
4,117,735. PUB. 1-10-2012. INT. CL. 20.

CLOUGHERTY PACKING, LLC, LOS ANGELES, CA:
2,968,116. CANC. INT. CL. 29.

CLUB CONFLICT, INC., BEAVER FALLS, PA:
4,118,481. PUB. 1-10-2012. INT. CL. 41.

CLUB MEDITERRANEE, 75019 PARIS, FRANCE:
2,965,427. CANC. MULTIPLE CLASS, INT. CLS. 14, 16, 18, 24, 25, 28, 35, 38, 39, 41 AND 42.

CLUBB, MICHAEL, CHINO, CA:
4,118,180. PUB. 1-10-2012. INT. CL. 45.

CMGC CONSULTING, L.C., SALT LAKE CITY, UT:
4,117,948. PUB. 1-10-2012. INT. CL. 41.

COATEX S.A., SOCIETE ANONYME, 69730 GENAY, FRANCE:
2,523,975. REN. 2-22-12. INT. CL. 1.

COCA-COLA COMPANY, THE, ATLANTA, GA:
2,467,921. CANC. INT. CL. 9.

CODEGEAR LLC, SCOTTS VALLEY, CA:
2,968,258. CANC. MULTIPLE CLASS, INT. CLS. 9, 41 AND 42.

COGNEX CORPORATION, NATICK, MA:
4,118,802. INT. CL. 9.

COGNITIVE SCIENCE LLC, ITHACA, NY:
4,119,428. INT. CL. 44.

COHANSEY COVE PUBLISHING, INC., CAPE MAY, NJ:
2,480,026. REN. 2-22-12. INT. CL. 35.

COHEN FOX P.A., MIAMI, FL:
4,119,454. INT. CL. 45.

COHEN RESEARCH GROUP, INC., WASHINGTON, DC, DBA COHEN RESEARCH GROUP:
4,117,852. PUB. 1-10-2012. INT. CL. 9.

COHEN, PHYLLIS, LONDON, UNITED KINGDOM:
4,119,782. INT. CL. 16.

COHO SALES LLC, CLINTON, TN:
4,118,572. PUB. 1-10-2012. INT. CL. 1.

COLD ICE CORPORATION, OAKLAND, CA:
1,671,670. REN. 2-17-12. INT. CL. 10.

COLD NOSES, INC., NANTUCKET, MA:
1,669,861. REN. 2-22-12. INT. CL. 42.

COLEMAN COMPANY, INC., THE, WICHITA, KS:
2,467,502. CANC. MULTIPLE CLASS, INT. CLS. 4 AND 11.

- COLIMAN GRUPO SA DE CV, TECOMAN, MEXICO:
4,118,959, INT. CL. 31.
- COLLECTIVE CORE, ATLANTA, GA:
4,118,603, PUB. 1-10-2012. INT. CL. 45.
- COLLEGESCENE LLC, NORTH BELLMORE, NY:
4,117,978, PUB. 1-10-2012. INT. CL. 41.
- COLLINGTON CARE SERVICES, INC., MITCHELLVILLE, MD:
2,467,009, CANC. INT. CL. 42.
- COLLINS, ROBERT W. PH.D., P.C., SPRING LAKE, MI, DBA SOILING SOLUTIONS:
2,617,073, REN. 2-21-12. INT. CL. 16.
2,617,073, CANC. INT. CL. 42.
- COLLINSON AND COMPANY, INC., NORCROSS, GA:
4,117,267, PUB. 1-10-2012. MULTIPLE CLASS, INT. CLS. 35 AND 39.
- COLOPLAST A/S TRADEMARK DEPARTMENT, DENMARK:
4,097,677, COR. INT. CL. 10.
- COLORBOK, INC., DEXTER, MI:
2,967,766, CANC. INT. CL. 16.
- COLUMBIA ELEVATOR PRODUCTS CO., INC., BRIDGEPORT, CT:
4,118,763, INT. CL. 6.
4,118,765, INT. CL. 7.
- COLUMBIA INSURANCE COMPANY, OMAHA, NE:
4,118,913, INT. CL. 25.
4,119,173, INT. CL. 19.
- COLUMBUS BICENTENNIAL 2012, INC., COLUMBUS, OH, DBA 200COLUMBUS:
4,118,118, PUB. 1-10-2012. INT. CL. 35.
4,118,128, PUB. 1-10-2012. MULTIPLE CLASS, INT. CLS. 35 AND 41.
- COLUMBUS MANUFACTURING, INC., HAYWARD, CA:
2,832,850, CANC. INT. CL. 29.
- COLUMBUS STEEL CASTINGS COMPANY, COLUMBUS, OH:
1,660,741, REN. 2-23-12. INT. CL. 12.
- COMBEX, INC., LAKE GENEVA, WI, DBA CHANEY INSTRUMENT COMPANY:
4,119,273, MULTIPLE CLASS, INT. CLS. 9 AND 14.
- COMERCIALIZADORA ELORO, S.A., ESTADO DE MEXICO, MEXICO:
4,119,021, INT. CL. 32.
- COMERICA INCORPORATED, DETROIT, MI:
4,117,847, PUB. 1-10-2012. INT. CL. 36.
4,117,866, PUB. 1-10-2012. INT. CL. 36.
4,117,868, PUB. 1-10-2012. INT. CL. 42.
- COMFORT SYSTEMS USA, INC., HOUSTON, TX:
4,119,221, INT. CL. 37.
- COMMEMORATIVE BRANDS, INC., AUSTIN, TX:
4,117,424, PUB. 1-10-2012. INT. CL. 14.
- COMMERCIAL DEFEASANCE, LLC, CHARLOTTE, NC:
2,668,959, REN. 2-22-12. INT. CL. 36.
- COMMERCIAL LAW LEAGUE OF AMERICA, CHICAGO, IL:
4,117,983, PUB. 1-10-2012. INT. CL. 35.
- COMMEREX INTERNATIONAL, PLANO, TX:
4,117,149, PUB. 1-10-2012. INT. CL. 30.
- COMMEREX INTERNATIONAL LLC, PLANO, TX:
4,117,138, PUB. 1-10-2012. INT. CL. 30.
- COMMITMENT TO EXCELLENCE, INC., ATLANTA, GA:
4,117,775, PUB. 1-10-2012. INT. CL. 41.
- COMMON FUND FOR NONPROFIT ORGANIZATIONS, THE, WILTON, CT:
4,118,210, PUB. 1-10-2012. INT. CL. 36.
4,118,212, PUB. 1-10-2012. INT. CL. 36.
- COMMONWEALTH EQUITY SERVICES, INC., WALTHAM, MA:
2,525,975, REN. 2-21-12. INT. CL. 36.
- COMMONWEALTH OIL CORPORATION, HARROW ONTARIO, CANADA:
2,966,152, CANC. INT. CL. 4.
- COMMUNICATION SERVICE FOR THE DEAF, INC., SIOUX FALLS, SD:
2,968,173, CANC. MULTIPLE CLASS, INT. CLS. 38 AND 41.
- COMMUNITY BANK, PASADENA, CA:
1,710,382, REN. 2-23-12. INT. CL. 36.
- COMPAÑIA NACIONAL DE CHOCOLATES, S.A., 143 MEDALLÍN, COLOMBIA:
4,116,645, PUB. 1-10-2012. INT. CL. 30.
- COMPARENETWORKS, INC., SOUTH SAN FRANCISCO, CA:
2,488,683, REN. 2-17-12. INT. CL. 42.
- COMPASS BANCSHARES, INC., BIRMINGHAM, AL:
4,117,454, PUB. 1-10-2012. INT. CL. 41.
4,117,456, PUB. 1-10-2012. INT. CL. 41.
4,117,457, PUB. 1-10-2012. INT. CL. 41.
- COMPASS GROUP USA, INC., CHARLOTTE, NC:
562,516, REN. 2-22-12. U.S. CL. 2 (INT. CL. 21).
2,663,157, REN. 2-21-12. INT. CL. 35.
2,663,158, REN. 2-21-12. INT. CL. 35.
- COMPETENCY MANAGEMENT INCORPORATED, HENDERSON, NV:
1,735,207, REN. 2-22-12. INT. CL. 35.
- COMPLIANCE IMPLEMENTATION SERVICES, MEDIA, PA, AKA CIS:
4,118,131, PUB. 1-10-2012. MULTIPLE CLASS, INT. CLS. 41 AND 45.
- COMPTOIR NOUVEAU DE LA PARFUMERIE, PARIS, FRANCE:
4,116,910, PUB. 1-10-2012. INT. CL. 3.
- COMPUTER SCIENCES CORPORATION, EL SEGUNDO, CA:
2,468,061, CANC. INT. CL. 9.
- COMPUTER SCIENCES CORPORATION, FALLS CHURCH, VA:
4,117,055, PUB. 1-10-2012. INT. CL. 39.
- COMPUWARE CORPORATION, DETROIT, MI:
2,543,539, REN. 2-17-12. INT. CL. 35.
- COMSCORE, INC., RESTON, VA:
4,119,585, MULTIPLE CLASS, INT. CLS. 35 AND 42.
4,119,697, INT. CL. 35.
- COMTREND CORPORATION, TAIPEI HSIEN, TAIWAN:
4,117,253, PUB. 1-10-2012. INT. CL. 9.
- CONAGRA FOODS LAMB WESTON, INC., KENNEWICK, WA:
1,185,018, REN. 2-22-12. INT. CL. 29.
- CONAN DOYLE ESTATE LIMITED, SOUTHAMPTON, UNITED KINGDOM:
4,117,117, PUB. 1-10-2012. INT. CL. 16.
- CONBRACO INDUSTRIES, INC., MATTHEWS, NC:
555,462, REN. 2-22-12. U.S. CL. 13 (INT. CL. 9).
- CONCAVUS INC., ROUND ROCK, TX:
4,117,617, PUB. 1-10-2012. INT. CL. 35.
- CONCEALED OUTDOORS, LLC, OWOSSO, MI:
4,117,812, PUB. 1-10-2012. INT. CL. 6.
- CONCEPT AMENITIES PTY. LTD., BRAESIDE, 3195, VICTORIA, 3195, AUSTRALIA:
2,467,033, CANC. INT. CL. 3.
- CONCEPT SYSTEMS INTERNATIONAL GMBH, SCHWARZENBRUCK, FED REP GERMANY:
2,533,535, REN. 2-22-12. INT. CL. 41.
- CONCORDIA PUBLISHING HOUSE, ST. LOUIS, MO:
948,572, REN. 2-22-12. U.S. CL. 38 (INT. CL. 16).
- CONDOS, CHRISTOPHER, SANTA ROSA, CA:
3,620,807, COR. INT. CL. 33.
- CONFLICT CONNECTIONS INC., SAN ANTONIO, TX:
4,117,360, PUB. 1-10-2012. INT. CL. 41.
4,117,428, PUB. 1-10-2012. INT. CL. 41.
- CONIGLIO, FRANK STEPHEN, WEST PALM BEACH, FL:
2,651,910, REN. 2-21-12. INT. CL. 43.
- CONLEY, PAUL F., NEW YORK, NY:
4,117,818, PUB. 1-10-2012. INT. CL. 42.
- CONN-SELMER, INC., ELKHART, IN, LUDWIG INDUSTRIES, CHICAGO, IL:
926,866, REN. 2-22-12. U.S. CL. 36 (INT. CLS. 9 AND 15).
- CONN'S, INC., BEAUMONT, TX:
4,118,560, PUB. 1-10-2012. INT. CL. 35.
- CONNECTIONS EDUCATION, LLC, BALTIMORE, MD:
4,119,495, MULTIPLE CLASS, INT. CLS. 41 AND 42.
4,119,513, MULTIPLE CLASS, INT. CLS. 41 AND 42.

CONNELLY, JAMES M., VIENNA, VA:
2,538,865. REN. 2-22-12. INT. CL. 31.
2,642,711. REN. 2-22-12. INT. CL. 43.

CONNERS, DAVID C., SAN DIEGO, CA:
2,571,144. REN. 2-19-12. INT. CL. 41.

CONOCOPHILLIPS COMPANY, HOUSTON, TX:
2,968,262. CANC. INT. CL. 36.

CONOPCO, INC., ENGLEWOOD CLIFFS, NJ:
2,968,588. CANC. INT. CL. 14.

CONSERVATION LAW FOUNDATION, INC., BOSTON, MA:
4,117,278. PUB. 1-10-2012. MULTIPLE CLASS, INT. CLS.
35 AND 36.

CONSOciate, INC., DECATUR, IL:
2,572,467. REN. 2-21-12. INT. CL. 36.

CONSTANT COMPLIANCE INCORPORATED, CHICAGO,
IL:
2,968,139. CANC. INT. CL. 9.

CONSTELLATION ENERGY GROUP, INC., BALTIMORE,
MD:
2,968,098. CANC. INT. CL. 36.

CONSTELLATION WINES U.S., INC., CANANDAIGUA, NY:
2,968,069. CANC. INT. CL. 33.

CONTEMPORARY CONTROL SYSTEMS, INC., DOWNERS
GROVE, IL:
4,119,756. INT. CL. 9.

CONTEX A/S, ALLEROED, DENMARK:
2,959,579. CANC. MULTIPLE CLASS, INT. CLS. 9 AND
42.

CONTINENTAL REIFEN DEUTSCHLAND GMBH, HANN-
OVER, FED REP GERMANY:
2,542,199. REN. 2-22-12. INT. CL. 12.

CONTRACT LAND STAFF, LLC, SUGAR LAND, TX:
4,119,762. INT. CL. 36.

CONTRACT MANAGEMENT SOLUTIONS, INC., WINTER
PARK, FL:
2,967,709. CANC. MULTIPLE CLASS, INT. CLS. 9 AND
42.

CONTROL CONCEPTS CORPORATION, BINGHAMTON,
NY:
2,468,259. CANC. INT. CL. 9.

CONVERGENT MEDIA NETWORK, INC., SEATTLE, WA
AND SUDDEN IMPACT PARTNERS, INC., SEATTLE,
WA:
2,968,395. CANC. INT. CL. 32.

CONVERTIDORA DE PAPEL DEL NOROESTE S.A. DE C.V.,
TIJUANA, MEXICO:
4,118,538. PUB. 1-10-2012. INT. CL. 16.

CONWAY GOLF, LLC, FREEVILLE, NY:
4,119,183. INT. CL. 28.

COOK MEDICAL TECHNOLOGIES LLC, BLOOMINGTON,
IN:
4,117,389. PUB. 1-10-2012. INT. CL. 10.
4,117,390. PUB. 1-10-2012. INT. CL. 10.

COOKE, IRA R., MELBOURNE, VICTORIA, AUSTRALIA:
4,118,487. PUB. 1-10-2012. INT. CL. 9.

COOKIE FAIRY SWEETS, INC., BROOKLYN, NY:
4,119,514. INT. CL. 30.

COOL BY 10[®] LLC, GREENFIELD, MO:
4,119,839. INT. CL. 6.
4,119,840. INT. CL. 20.

COOLEY GROUP HOLDINGS, INC, PAWTUCKET, RI:
1,675,104. REN. 2-17-12. INT. CL. 20.
1,715,875. REN. 2-17-12. INT. CL. 24.

COOPER, MACDELLA, NY, NY AND TAFUTO, THOMAS,
F, NY, NY:
4,117,093. PUB. 1-10-2012. MULTIPLE CLASS, INT. CLS.
25, 41, 42 AND 45.

COP, DIDIER, PASO ROBLES, CA:
2,968,332. CANC. INT. CL. 43.
2,968,333. CANC. MULTIPLE CLASS, INT. CLS. 35 AND
43.

CORBIN, ANTON, CHRISTIAN, SAN DIEGO, CA:
2,968,101. CANC. INT. CL. 25.

CORDRAY, JULIA, CALGARY, ALBERTA, CANADA:
4,118,087. PUB. 1-10-2012. INT. CL. 35.

CORE CALLING, LLC, LONGMONT, CO:
4,117,856. PUB. 1-10-2012. INT. CL. 41.

CORONA CLIPPER, INC., CORONA, CA, HARROW PRO-
DUCTS, INC., GRAND RAPIDS, MI:
1,691,192. REN. 2-17-12. INT. CL. 8.

CORPORATE KINGDOM, LLC, SALT LAKE CITY, UT:
2,967,489. CANC. MULTIPLE CLASS, INT. CLS. 16 AND
21.

CORPORATE SERVICES GROUP HOLDINGS, INC., HOUS-
TON, TX:
2,527,589. REN. 2-23-12. INT. CL. 42.

CORPORATION ZEDBED INTERNATIONAL INC.,
GRAND-MERE, QUEBEC, CANADA:
4,116,641. PUB. 1-10-2012. INT. CL. 20.
4,116,642. PUB. 1-10-2012. INT. CL. 20.

CORREA MANAGEMENT, INC., LA MESA, CA, DBA
SOMBREIRO MEXICAN FOOD:
4,117,773. PUB. 1-10-2012. INT. CL. 43.

CORRIGO INCORPORATED, TUALATIN, OR:
2,534,959. REN. 2-22-12. INT. CL. 42.
2,534,959. COR. INT. CL. 42.

CORSICA ENTERPRISES, LTD., PERKASIE, PA:
4,118,149. PUB. 1-10-2012. INT. CL. 35.

CORTEZ, KEVIN, FRISCO, TX:
4,118,264. PUB. 1-10-2012. INT. CL. 35.

COSMETIC CHANGES, LLC, AVENTURA, FL:
4,118,771. INT. CL. 3.

COSMETIC WARRIORS LTD., POOLE, DORSET, UNITED
KINGDOM:
4,118,438. PUB. 1-10-2012. INT. CL. 3.

COSTA RAFFAELE, UNITED KINGDOM:
4,116,700. PUB. 1-10-2012. MULTIPLE CLASS, INT. CLS.
9, 16 AND 41.

COSWAY (M) SDN. BHD. (COMPANY NO. 50118-A), 50200
KUALA LUMPUR, MALAYSIA:
4,119,116. INT. CL. 1.

COTTERWEB ENTERPRISES, INC., MENDOTA HEIGHTS,
MN:
4,119,426. INT. CL. 35.
4,119,427. INT. CL. 35.

COUNCIL FOR LIFE, DALLAS, TX:
4,118,072. PUB. 1-10-2012. INT. CL. 36.

COUNTRY BOY SEED, INC., BRISTOL, VA:
4,118,575. PUB. 1-10-2012. INT. CL. 1.
4,118,577. PUB. 1-10-2012. INT. CL. 31.

COUNTRY LIFE, LLC, HAUPPAUGE, NY:
4,119,393. INT. CL. 5.

COUNTY COMMISSIONERS OF CARROLL COUNTY,
WESTMINSTER, MD:
4,117,562. PUB. 1-10-2012. INT. CL. 35.

COUPLAMATIC SYSTEMS, INC., SCOTSSBLUFF, NE,
HOUSE OF HOSE, SCOTSSBLUFF, NE:
1,720,281. REN. 2-23-12. INT. CL. 17.

COUPLAMATIC SYSTEMS, INC., SCOTSSBLUFF, NE,
HOUSE OF HOSE, SCOTSSBLUFF, NE:
1,725,054. REN. 2-23-12. INT. CL. 7.

COURTROOM TELEVISION NETWORK LLC, NEW YORK,
NY:
2,967,637. CANC. INT. CL. 41.

COUTURE COLOUR LLC, LOS ANGELES, CA:
4,119,492. MULTIPLE CLASS, INT. CLS. 3, 11, 21, 25 AND
26.

COVEN, ANDREW, SOUTH SAN FRANCISCO, CA:
2,468,096. CANC. INT. CL. 9.

COVERALL NORTH AMERICA, INC., BOCA RATON, FL:
4,119,657. MULTIPLE CLASS, INT. CLS. 35 AND 37.

COWBOY ARTISTS OF AMERICA, TUCSON, AZ, COWBOY
ARTISTS OF AMERICA, OKLAHOMA CITY, OK:
926,589. REN. 2-22-12. U.S. CL. 200.

COWEN, STEPHEN R., LONGMONT, CO:
4,119,270. INT. CL. 11.

CO2NEXUS, INC., DENVER, CO:
4,118,916. INT. CL. 7.

CPL SYSTEMS CANADA INC., CAMPBELVILLE, ONTAR-
IO, CANADA:
2,468,305. CANC. INT. CL. 9.

CPS PHOTOGRAPHY, LLC, PITCAIRN, PA:
4,118,093. PUB. 1-10-2012. INT. CL. 41.

CQMS PTY LTD, QUEENSLAND 4000, AUSTRALIA:
4,117,273. PUB. 1-10-2012. INT. CL. 7.

- CRAFT INTERNATIONAL, LLC, DALLAS, TX:
4,117,985, PUB. 1-10-2012. INT. CL. 45.
- CRAIG W. NELSON REVOCABLE TRUST, WESTCHESTER-FIELD, NH:
4,119,047, INT. CL. 28.
- CRAPPS, ELIZABETH, CANTON, MI:
4,117,462, PUB. 1-10-2012. INT. CL. 36.
- CRC HEALTH CORPORATION, CUPERTINO, CA:
4,117,150, PUB. 1-10-2012. INT. CL. 44.
- CREANDO ESTILOS S.A. CRESTILSA, GUAYAQUIL, ECUADOR:
4,117,126, PUB. 1-10-2012. INT. CL. 25.
- CREATIVE RESEARCH LABS, INC., WAKE FOREST, NC:
4,119,686, INT. CL. 3.
- CREMIEUX, STÉPHANE, 75116 PARIS,, FRANCE:
4,116,660, PUB. 1-10-2012. INT. CL. 25.
- CRESCENT CONSTRUCTION SERVICES, LLC, SALISBURY, NC, DBA CRESCENT CONSTRUCTION SERVICES:
4,117,469, PUB. 1-10-2012. INT. CL. 42.
- CRESCENT METAL PRODUCTS, INC., MENTOR, OH:
2,968,030, CANC. INT. CL. 11.
2,968,031, CANC. INT. CL. 11.
- CRETO INTERNATIONAL, INC., LAKE ORION, MI:
2,941,897, CANC. INT. CL. 1.
- CREW ENTERPRISES, INC., VILLANOVA, PA:
2,467,412, CANC. INT. CL. 36.
- CRISPIN, JESSICA D., LINCOLN, KS, DBA CRISPIN, JESSA:
4,118,041, PUB. 1-10-2012. INT. CL. 41.
- CRITICAL SIGNAL TECHNOLOGIES, INC., FARMINGTON HILLS, MI:
4,119,095, INT. CL. 44.
- CRO-BAR, L.L.C., KINGSPORT, TN:
4,117,002, PUB. 1-10-2012. INT. CL. 43.
- CROREY, DAVID J., CLINTON TOWNSHIP, MI:
2,968,289, CANC. INT. CL. 9.
- CROSBY, MIKE T., VISTA, CA:
4,119,574, INT. CL. 25.
- CROSSROAD PUBLISHING COMPANY, INC., THE, CHESTNUT RIDGE, NY:
2,527,882, REN. 2-21-12. INT. CL. 41.
- CROSSROCK CASE COMPANY, SAN GABRIEL, CA:
4,118,453, PUB. 1-10-2012. INT. CL. 15.
- CROWE, JESSE, IRVINE, CA:
4,118,114, PUB. 1-10-2012. INT. CL. 35.
- CROWN PAWNBROKERS INC, WASHINGTON, DC:
4,119,320, INT. CL. 36.
- CRU-VAR CORPORATION, LAUREL, MD:
4,119,266, MULTIPLE CLASS, INT. CLS. 39 AND 43.
- CRUM, MICHAEL, COLUMBUS, OH, DBA A ALL AROUND LOCKSMITHS:
4,118,239, PUB. 1-10-2012. INT. CL. 45.
- CRUZ, ANTONIO PAULINO, LINCOLN, RI:
4,117,648, PUB. 1-10-2012. INT. CL. 44.
- CRYOVAC, INC., ELMWOOD PARK, NJ:
4,118,876, INT. CL. 17.
4,119,706, INT. CL. 17.
- CRYSTAL ICING, LLC, ROCHESTER, NY:
4,117,449, PUB. 1-10-2012. INT. CL. 9.
- CSAFE, LLC, DAYTON, OH:
4,116,567, PUB. 1-10-2012. INT. CL. 11.
- CTB, INC., MILFORD, IN:
4,116,988, PUB. 1-10-2012. INT. CL. 7.
- CTC HOLDINGS, L.P., CHICAGO, IL:
4,116,966, PUB. 1-10-2012. INT. CL. 36.
- CUA, IRENE L., ROSEMEAD, CA:
2,627,865, REN. 2-22-12. INT. CL. 5.
2,630,940, REN. 2-22-12. INT. CL. 5.
2,630,941, REN. 2-22-12. INT. CL. 5.
- CUBICLE DECOR LLC, LOUISVILLE, KY:
2,968,256, CANC. INT. CL. 20.
- CUBIKS INTELLECTUAL PROPERTY LIMITED, UNITED KINGDOM:
4,116,749, PUB. 1-10-2012. INT. CL. 9.
- CUMBERLAND PACKING CORP., BROOKLYN, NY:
4,117,522, PUB. 1-10-2012. INT. CL. 30.
- CUNNINGHAM, ARGUS I., FPO AE, ITALY:
4,119,064, INT. CL. 42.
4,119,065, INT. CL. 42.
- CUPID FOUNDATIONS, INC., NEW YORK, NY:
4,118,613, PUB. 1-10-2012. INT. CL. 25.
- CURADEBT SYSTEMS, LLC, RENO, NV:
4,118,529, PUB. 1-10-2012. INT. CL. 36.
- CURANA INVEST BVBA, BELGIUM:
4,116,738, PUB. 1-10-2012. INT. CL. 12.
- CURASCRIPIT, INC., ORLANDO, FL:
2,801,996, CANC. INT. CL. 44.
2,804,384, CANC. INT. CL. 44.
2,804,385, CANC. INT. CL. 44.
2,804,386, CANC. INT. CL. 44.
- CURIOUS EMPORIUM, LTD., BETHANY, OK:
2,522,299, REN. 2-21-12. INT. CL. 35.
- CURRENT GROUP, LLC, GERMANTOWN, MD:
4,118,686, PUB. 1-10-2012. MULTIPLE CLASS, INT. CLS. 35, 39 AND 42.
- CURTIS INDUSTRIES LLC, WORCESTER, MA:
4,119,130, INT. CL. 7.
- CURWOOD, INC., OSHKOSH, WI:
4,117,443, PUB. 1-10-2012. INT. CL. 17.
- CUSTOM ENGINEERING S.P.A., FONTEVIVO (PARMA), ITALY:
4,116,769, PUB. 1-10-2012. INT. CL. 9.
- CUSTOM HOTEL, LLC, SAN FRANCISCO, CA:
4,119,828, INT. CL. 43.
- CUSTOM PRINTING II, LTD., BELTON, TX:
2,968,406, CANC. MULTIPLE CLASS, INT. CLS. 30 AND 35.
- CUSTOMER FOCUS, INC., ALPHARETTA, GA:
4,118,260, PUB. 1-10-2012. INT. CL. 41.
- CUSTOMSTART L.L.C., PARADISE VALLEY, AZ:
3,036,447, COR. INT. CL. 42.
- CVD INCORPORATED, MARLBOROUGH, MA:
1,706,105, REN. 2-19-12. INT. CL. 1.
- CVM AFFILIATES, INC., OAKS, PA:
4,117,261, PUB. 1-10-2012. MULTIPLE CLASS, INT. CLS. 37 AND 42.
- CYCLES GURU INC./GURU CYCLES INC., LAVAL, QUEBEC, CANADA:
2,539,531, REN. 2-17-12. INT. CL. 12.
- CYTOS BIOTECHNOLOGY AG, ZURICH-SCHLIEREN, SWITZERLAND:
2,467,070, CANC. INT. CL. 42.
- D & S CAR WASH EQUIPMENT COMPANY, HIGH RIDGE, MO:
2,467,015, CANC. INT. CL. 3.
- D CUBED GROUP LLC, NEW YORK, NY:
4,119,022, INT. CL. 36.
4,119,023, INT. CL. 36.
4,119,024, INT. CL. 36.
4,119,025, INT. CL. 36.
4,119,441, INT. CL. 36.
- D&K S.R.L., FIRENZE, ITALY:
2,965,600, CANC. MULTIPLE CLASS, INT. CLS. 3, 18, 20, 24, 25 AND 35.
- D&S EXPORTS, INC., NORWALK, CT:
4,118,150, PUB. 1-10-2012. INT. CL. 7.
- D-M-E COMPANY, MADISON HEIGHTS, MI:
2,967,700, CANC. INT. CL. 7.
- DA DIRECT INC., DALLAS, TX:
4,118,221, PUB. 1-10-2012. MULTIPLE CLASS, INT. CLS. 18 AND 35.
- DA VE WINERY, INC., NAPA, CA, DBA SPIRAL WINES:
4,118,567, PUB. 1-10-2012. INT. CL. 33.
- DABBLERS LLC, CONCORD, MA:
4,117,438, PUB. 1-10-2012. MULTIPLE CLASS, INT. CLS. 35, 41 AND 43.
- DACOSTA FANE C., HOLLY HILL, FL:
4,117,372, PUB. 1-10-2012. INT. CL. 35.
- DAE-IL USA, INC., MORGAN HILL, CA:
2,967,564, CANC. MULTIPLE CLASS, INT. CLS. 7 AND 12.
- DAIRY MANAGEMENT, INC., ROSEMONT, IL:
4,118,672, PUB. 1-10-2012. MULTIPLE CLASS, INT. CLS. 35 AND 41.

DAISYWORKS, INC., ROCHESTER, NY:
4,119,653, INT. CL. 9.

DALE PICARD, TORRINGTON, CT AND LUCILLE PICARD, TORRINGTON, CT:
4,117,251, PUB. 1-10-2012. INT. CL. 41.
4,117,255, PUB. 1-10-2012. INT. CL. 41.

DALE'S SAUCES, INC., BIRMINGHAM, AL:
4,117,676, PUB. 1-10-2012. INT. CL. 30.
4,117,677, PUB. 1-10-2012. INT. CL. 30.

DALER-ROWNEY LIMITED, BERKSHIRE, UNITED KINGDOM:
4,117,174, PUB. 1-10-2012. MULTIPLE CLASS, INT. CLS. 2 AND 16.

DALEY, ELISABETH SCOTT, WILLIAMSBURG, VA AND MERRY, JR., PETER CHARLES, LADERA RANCH, CA:
4,117,619, PUB. 1-10-2012. INT. CL. 41.

DALLAS IS LOVE, GARLAND, TX:
4,118,268, PUB. 1-10-2012. INT. CL. 36.

DALTILE DISTRIBUTION, INC., CALHOUN, GA:
4,117,914, PUB. 1-10-2012. INT. CL. 36.

DAN TAIEB, ISRAEL:
4,116,821, PUB. 1-10-2012. MULTIPLE CLASS, INT. CLS. 6 AND 14.

DAN-DEE INTERNATIONAL, LTD., JERSEY CITY, NJ:
2,522,561. REN. 2-21-12. INT. CL. 28.

DANA DESHUN AKBAR, CEDAR HILL, TX AND DARCUS DEON ROBERSON, CEDAR HILL, TX:
4,119,314, INT. CL. 25.

DANIEL MID-ATLANTIC PROPERTIES II, LLC, BIRMINGHAM, AL:
2,967,618, CANC. INT. CL. 36.

DANIELS, FRANCIS PATRICK, NEW MILTON, WV:
2,467,972, CANC. INT. CL. 8.

DANNER, INC., PORTLAND, OR:
4,119,059, INT. CL. 25.

DANNY DID FOUNDATION, CHICAGO, IL:
4,118,462, PUB. 1-10-2012. INT. CL. 35.

DARIN HAYES, COEUR D'ALENE, ID:
4,117,907, PUB. 1-10-2012. INT. CL. 36.

DARKHORSE GEOSPATIAL LLC, ANNAPOLIS, MD:
4,117,781, PUB. 1-10-2012. INT. CL. 35.

DARREN BRADY CPA PC, CHARLOTTE, NC:
4,119,700, INT. CL. 35.

DARWIN HOLDINGS, INC., PRINCETON, NJ, AKA ARGALI SOFTWARE:
2,588,863. REN. 2-21-12. INT. CL. 9.

DASH CLOTHING, INC., NEW YORK, NY:
4,119,281, INT. CL. 25.

DATA COM SYSTEMS, INC., EAST SYRACUSE, NY:
2,968,282, CANC. INT. CL. 9.

DATALOGIC SCANNING, INC., EUGENE, OR:
4,116,620, PUB. 1-10-2012. INT. CL. 9.

DATAVIZ, INC., MILFORD, CT:
2,967,858, CANC. INT. CL. 9.

DAVE SHEPARD ENTERPRISES, INC., HILLSBORO, OR:
4,119,825, INT. CL. 25.
4,119,826, INT. CL. 25.

DAVID & GOLIATH LLC, EL SEGUNDO, CA:
4,119,202, INT. CL. 25.

DAVID FREEMAN, LAGUNA BEACH, CA:
4,119,707, INT. CL. 45.

DAVID TILLMAN, ORLANDO, FL AND LYNN TILLMAN, ORLANDO, FL:
4,117,339, PUB. 1-10-2012. INT. CL. 41.

DAVID V. GLORIOUS, FT. MCCOY, FL:
4,117,955, PUB. 1-10-2012. INT. CL. 45.

DAVIS, BARROW, HOLLYWOOD, CA:
2,968,263, CANC. INT. CL. 9.

DAVIS, MELVIN, CHICAGO, IL:
4,117,056, PUB. 1-10-2012. INT. CL. 25.

DAYMEN CANADA ACQUISITION ULC, VANCOUVER, BC, CANADA:
4,119,594, INT. CL. 9.
4,119,637, INT. CL. 18.

DAYTON ELECTRIC MANUFACTURING CO., NILES, IL:
2,468,002, CANC. INT. CL. 16.

DC COMICS, NEW YORK, NY, DC COMICS INC., NEW YORK, NY:
1,182,947. REN. 2-21-12. INT. CL. 18.
1,183,809. REN. 2-22-12. INT. CL. 21.
1,183,841. REN. 2-22-12. INT. CL. 24.

DCCO, LLC, MCLEAN, VA:
4,116,589, PUB. 8-26-2008. MULTIPLE CLASS, INT. CLS. 35 AND 39.

DD IP HOLDER LLC, CANTON, MA:
4,119,880, INT. CL. 30.

DE MARIN DE MONTMARIN EDOUARD, FRANCE:
4,081,968, COR. MULTIPLE CLASS, INT. CLS. 35, 38 AND 41.

DEALER TIRE, LLC, CLEVELAND, OH:
4,117,159, PUB. 1-10-2012. INT. CL. 35.

DEAN M. ROLL, CENTERVILLE, OH:
4,117,130, PUB. 1-10-2012. INT. CL. 41.

DEAN MARKLEY STRINGS, INC., SANTA CLARA, CA:
2,967,481, CANC. INT. CL. 15.

DEBBIE MACOMBER, INC., PORT ORCHARD, NY:
4,117,394, PUB. 1-10-2012. INT. CL. 9.

DEBRA WEISS, LOS ANGELES, CA:
4,117,194, PUB. 1-10-2012. INT. CL. 41.

DECEUNINCK NORTH AMERICA, LLC, MONROE, OH:
2,968,632, CANC. INT. CL. 19.

DECK GEAR LLC, VENICE, FL:
4,119,854, INT. CL. 12.

DECORATIVE HARDWARE STUDIO, INC., CHAPPAQUA, NY:
2,614,239. REN. 2-22-12. MULTIPLE CLASS, INT. CLS. 6 AND 20.

DEGRAFF, JEFFREY T., ANN ARBOR, MI:
4,117,207, PUB. 1-10-2012. INT. CL. 41.

DEGREE CONTROLS, INC., MILFORD, NH:
2,514,412. REN. 2-17-12. INT. CL. 9.

DEL GRIPPO, GREGORY A., BEDMINSTER, NJ:
4,118,775, INT. CL. 20.

DEL MEYER, M.D., CARMICHAEL, CA:
2,966,201, CANC. MULTIPLE CLASS, INT. CLS. 36 AND 38.

DELICIAS DE MICHOCAN, INC., ONTARIO, CA:
4,119,588, INT. CL. 30.

DELICIOUS INC., SAN ANTONIO, TX:
4,118,112, PUB. 1-10-2012. MULTIPLE CLASS, INT. CLS. 29 AND 30.

DELSTAR PUBLISHING, LAS VEGAS, NV:
2,468,126, CANC. MULTIPLE CLASS, INT. CLS. 9 AND 16.

DELTA CREATIVE, INC., CITY OF INDUSTRY, CA:
2,968,247, CANC. INT. CL. 16.

DELTA SOFTWARE INTERNATIONAL, L.L.C., OWASSO, OK:
2,968,074, CANC. INT. CL. 9.

DELTATRAK, INC., CONCORD, CA:
2,519,790. REN. 2-21-12. INT. CL. 9.

DELUS, ADAMS, FLUSHING, NY:
2,965,603, CANC. INT. CL. 25.

DEMARCHI, KENN J, RIVERVALE, NJ:
2,657,448. REN. 2-21-12. INT. CL. 42.

DEMERELL, ANNALEE RENEE PICKNELL, CHARLESTON, SC:
4,119,291, MULTIPLE CLASS, INT. CLS. 18 AND 25.

DEMROSE, RICHARD S., DEARBORN, MI AND DEMROSE, SHARON, DEARBORN, MI:
2,967,818, CANC. INT. CL. 28.

DENKI KAGAKU KOGYO KABUSHIKI KAISHA, CHUOKU, TOKYO, JAPAN:
1,675,072. REN. 2-22-12. INT. CL. 17.

DENNIS, TINA, MAMARONECK, NY:
4,119,252, INT. CL. 25.

DENOMINATOR COMPANY, INC., THE, WOODBURY, CT, DENOMINATOR COMPANY, THE, NEW YORK 7, NY:
552,491. REN. 2-19-12. U.S. CL. 26 (INT. CL. 9).

DENTSPLY INTERNATIONAL INC., YORK, PA, TDP, INC., TULSA, OK:
1,711,082. REN. 2-21-12. INT. CL. 5.

DENTSPLY INTERNATIONAL INC., YORK, PA:
2,649,452. REN. 2-21-12. INT. CL. 10.

- DEPARTMENT OF THE ARMY, WASHINGTON, DC:
2,524,345. REN. 2-22-12. U.S. CL. 200.
- DEPUGLIO, JOE SAINT MICHAEL, TRENTON, NJ:
2,658,821. REN. 2-23-12. INT. CL. 9.
- DEPUY, INC., WARSAW, IN:
2,968,274. CANC. INT. CL. 10.
- DESCENTE NORTH AMERICA, INC., LAYTON, UT:
4,119,385. INT. CL. 25.
- DESCURITY, INC., FREMONT, CA:
2,967,868. CANC. INT. CL. 9.
- DESIGN BASICS, LLC, OMAHA, NE:
2,653,478. REN. 2-17-12. MULTIPLE CLASS, INT. CLS. 9,
16 AND 42.
- DESIGN FORUM, LLC, DAYTON, OH:
2,967,636. CANC. INT. CL. 35.
- DESIGNERS REMIX COLLECTION A/S, DENMARK:
2,967,230.
- DESIGNS BY FMC, INC., BROOKLYN, NY:
4,119,408. INT. CL. 14.
- DESMOULIN, INC, MISSOURI CITY, TX:
2,468,362. CANC. INT. CL. 25.
- DESTILADORA IBARRRA, S.A. DE C.V., C.P. 11100, MEX-
ICO, D.F., MEXICO:
2,967,628. CANC. INT. CL. 33.
- DETROIT DIESEL CORPORATION, DETROIT, MI:
1,739,682. REN. 2-23-12. INT. CL. 12.
- DETROIT RED WINGS, INC., DETROIT, MI:
1,694,497. REN. 2-23-12. INT. CL. 25.
1,741,388. REN. 2-23-12. INT. CL. 25.
- DEUKALION, DOVER, MA:
4,118,309. PUB. 1-10-2012. INT. CL. 25.
- DEVILBISS HEALTHCARE LLC, SOMERSET, PA:
4,050,249. COR. INT. CL. 10.
- DHARMA HOLDINGS LTD., SEATTLE, WA, DBA RAISING
MORE MONEY:
2,967,442. CANC. MULTIPLE CLASS, INT. CLS. 16 AND
41.
- DIAGEO IRELAND, DUBLIN 8, IRELAND:
4,116,922. PUB. 1-10-2012. INT. CL. 32.
- DIAGEO IRELAND, DUBLIN, IRELAND:
4,116,923. PUB. 1-10-2012. INT. CL. 32.
- DIAMONDLITE INVESTMENTS LIMITED, HONG KONG
SP ADMIN REG, CHINA:
4,118,854. INT. CL. 14.
- DIANE CATHERINE BERRY, STUDIO CITY, CA:
4,118,536. PUB. 1-10-2012. INT. CL. 41.
- DIAZ SUNPROTECTION NV, TIELT, BELGIUM AND DM
CROSS ASSOCIATES, LLC, NORWALK, CT:
4,117,767. PUB. 1-10-2012. MULTIPLE CLASS, INT. CLS.
20 AND 24.
- DIEBOLD, INCORPORATED, NORTH CANTON, OH:
1,681,756. REN. 2-23-12. INT. CL. 6.
- DIET DIRECT, INC., WILMINGTON, NC:
4,118,179. PUB. 1-10-2012. MULTIPLE CLASS, INT. CLS. 5
AND 44.
- DIG MARKETING, RAMONA, CA:
4,116,909. PUB. 1-10-2012. INT. CL. 42.
- DIGILUBE SYSTEMS, INC., SPRINGBORO, OH:
1,672,927. REN. 2-23-12. MULTIPLE CLASS, INT. CLS. 4
AND 42.
- DIGITAL AGE LEARNING, LOS ANGELES, CA, DBA
DEVELOPMENTOR:
4,118,393. PUB. 1-10-2012. INT. CL. 41.
4,118,394. PUB. 1-10-2012. INT. CL. 41.
4,118,396. PUB. 1-10-2012. INT. CL. 41.
4,118,398. PUB. 1-10-2012. INT. CL. 41.
- DIGITAL BUSINESS SOLUTIONS, INC., IRVINE, CA:
4,119,876. INT. CL. 9.
- DIGITAL HIGHWAY, INC., BATTLE CREEK, MI:
4,118,141. PUB. 1-10-2012. INT. CL. 38.
- DIGITAL IMS, INC., LINCOLN, NE:
2,467,737. CANC. INT. CL. 42.
- DIGITALCUSTOM GROUP, INC., WALNUT CREEK, CA:
2,750,876. CANC. INT. CL. 42.
- DILEMMA X, ATLANTA, GA:
4,117,699. PUB. 1-10-2012. INT. CL. 35.
- DILETTANTE CHOCOLATES, INC., KENT, WA, DILET-
TANTE, INC., THE, SEATTLE, WA:
1,190,160. REN. 2-23-12. MULTIPLE CLASS, INT. CLS. 30
AND 42.
- DILL, JAMES, TYLER, TX:
4,117,730. PUB. 1-10-2012. INT. CL. 45.
- DILLARD'S, LITTLE ROCK, AR:
4,119,694. INT. CL. 14.
- DILLARD'S INC., LITTLE ROCK, AR:
2,967,604. CANC. INT. CL. 25.
- DILLON YARN CORPORATION, PATERSON, NJ:
4,117,827. PUB. 1-10-2012. INT. CL. 23.
- DILTEX, S.A. DE C.V., DE JUAREZ, EDO. DE, MEXICO:
4,119,230. INT. CL. 25.
- DIMICELI, ROBIN, COPPERPOLIS, CA:
4,119,681. INT. CL. 29.
- DIMPLEX NORTH AMERICA LIMITED, CAMBRIDGE,
ONTARIO, CANADA:
2,968,472. CANC. INT. CL. 35.
- DINE, KEVA MARIE, VISTA, CA:
2,529,227. REN. 2-22-12. INT. CL. 42.
- DIOMED DEVELOPMENTS LIMITED, HITCHIN, HERT-
FORDSHIRE, UNITED KINGDOM:
4,117,183. PUB. 1-10-2012. MULTIPLE CLASS, INT. CLS. 3
AND 5.
- DIRECT FEDERAL CREDIT UNION, NEEDHAM
HEIGHTS, MA:
4,118,191. PUB. 1-10-2012. INT. CL. 36.
- DIRECT HOLDINGS AMERICAS INC., FAIRFAX, VA:
4,118,781. INT. CL. 9.
- DIRECT MARKETING EXCELLENCE, INC., LITTLETON,
CO:
2,613,122. REN. 2-21-12. INT. CL. 35.
- DIRODDI, LOS ANGELES, CA:
4,118,280. PUB. 1-10-2012. MULTIPLE CLASS, INT. CLS.
35 AND 42.
- DIRTY BIRD PRODUCTIONS, LOS ANGELES, CA:
4,117,878. PUB. 1-10-2012. INT. CL. 28.
- DISCOVERY COMMUNICATIONS, LLC, SILVER SPRING,
MD:
4,119,268. INT. CL. 41.
- DISCOVERY TOYS, LLC, CHICAGO, IL:
2,968,197. CANC. INT. CL. 28.
- DISNEY ENTERPRISES, INC., BURBANK, CA:
2,649,963. REN. 2-17-12. INT. CL. 41.
4,116,561. PUB. 1-10-2012. INT. CL. 9.
4,118,780. MULTIPLE CLASS, INT. CLS. 14, 18, 20, 21, 24,
25, 28 AND 41.
4,118,912. INT. CL. 41.
4,119,030. INT. CL. 21.
4,119,509. INT. CL. 41.
- DISTILLERY SOLUTIONS, LLC, ARVADA, CO:
4,119,804. INT. CL. 35.
- DISTINXION INCORPORATED, WASHINGTON, IN:
4,118,628. PUB. 1-10-2012. INT. CL. 41.
- DIVERSEY, INC., STURTEVANT, WI, HYDRITE CHEMI-
CAL CO., BROOKFIELD, WI:
1,675,657. REN. 2-17-12. INT. CL. 3.
- DIVERSEY, INC., STURTEVANT, WI:
2,528,582. REN. 2-23-12. INT. CL. 3.
- DIVERSIFIED SEARCH, PHILADELPHIA, PA:
4,117,967. PUB. 1-10-2012. INT. CL. 41.
- DIVERSIFIED WORKPLACE, LLC, KELLER, TX:
4,119,758. INT. CL. 35.
- DIVINE INHERITANCE, INC., FRANKLIN, TN:
4,118,480. PUB. 1-10-2012. INT. CL. 14.
4,118,668. PUB. 1-10-2012. INT. CL. 43.
- DIVOTS SPORTSWEAR COMPANY, INC., NORCROSS, GA:
1,738,429. REN. 2-22-12. INT. CL. 25.
- DIX-RAY SOLUTION GMBH, FED REP GERMANY:
4,116,685. PUB. 1-10-2012. MULTIPLE CLASS, INT. CLS.
10 AND 44.
- DJ ASHBA, WEST HOLLYWOOD, CA:
4,119,341. INT. CL. 9.
- DOCUMENTARY ARTS, INC., DALLAS, TX:
4,119,721. MULTIPLE CLASS, INT. CLS. 9, 16 AND 41.
- DOGFISH HEAD MARKETING, LLC, MILTON, DE:
4,117,879. PUB. 1-10-2012. INT. CL. 32.

DOGTREKKER, INC., SAN RAFAEL, CA:
4,118,534, PUB. 1-10-2012. INT. CL. 35.

DOIG-MARX, GEOFFREY, NEW YORK, NY AND HARRIS,
BRUCE ROBERT, NEW YORK, NY:
2,968,182, CANC. INT. CL. 41.

DOLE FOOD COMPANY, INC., WESTLAKE VILLAGE, CA:
2,523,157. REN. 2-22-12. MULTIPLE CLASS, INT. CLS. 28
AND 31.

DOMETIC CORPORATION, ELKHART, IN, MANSFIELD
SANITARY, INC., PERRYSVILLE, OH:
912,283. REN. 2-23-12. U.S. CL. 13 (INT. CL. 11).

DOMICIL PTE. LTD., SINGAPORE:
3,492,931, COR. INT. CL. 24.

DOMINO'S IP HOLDER LLC, ANN ARBOR, MI:
2,467,258, CANC. INT. CL. 39.

DOMINUS ESTATE CORPORATION, YOUNTVILLE, CA:
2,631,962. REN. 2-22-12. INT. CL. 33.

DOMNITZ, ANITA, MILWAUKEE, WI:
2,968,366, CANC. INT. CL. 44.

DONALDSON COMPANY, INC., MINNEAPOLIS, MN:
1,676,421. REN. 2-22-12. INT. CL. 11.

DONAPALE PROMOCIONES, S.L., 48009 BIBAO, VIZCAYA,
SPAIN, MONDAY CLASSICS INC., HIALEAH GARDENS,
FL:
1,183,907. REN. 2-22-12. INT. CL. 25.

DONG LING, YUNNAN PROVINCE, CHINA:
4,118,600, PUB. 1-10-2012. INT. CL. 7.

DONG WU INVESTMENT CO., LTD., TAIPEI COUNTY 248,
TAIWAN:
4,119,366, MULTIPLE CLASS, INT. CLS. 36 AND 37.
4,119,367, MULTIPLE CLASS, INT. CLS. 36 AND 37.

DONGGUAN CITY SHENGLAN ELECTRONICS CO., LTD,
GUANGDONG, CHINA:
4,116,794, PUB. 1-10-2012. INT. CL. 9.

DONNELLAN, JENNIFER, SAN RAFAEL, CA:
2,967,825, CANC. INT. CL. 25.

DONNELLY, ROBERT JOSEPH, REDONDO BEACH, CA:
2,965,490, CANC. INT. CL. 25.

DOPF, ROBERT CHARLES, URBANDALE, IA:
2,968,521, CANC. INT. CL. 35.

DORIS ENGINEERING, F-75013 PARIS, FRANCE:
4,116,708, PUB. 1-10-2012. MULTIPLE CLASS, INT. CLS. 6
AND 42.

DORM DONKEY LLC, MIAMI, FL:
4,119,586, INT. CL. 35.
4,119,587, INT. CL. 35.

DORMA-CAROLINA DOOR CONTROLS, INC., DURHAM,
NC:
2,648,553. REN. 2-22-12. INT. CL. 37.

DORNIER, CONRADO, 82547 BEUERBERG, FED REP
GERMANY:
4,119,744, INT. CL. 12.

DOSS, GALAL PHILIP HABIB, LONDON, SW, UNITED
KINGDOM:
4,117,909, PUB. 1-10-2012. INT. CL. 41.
4,117,910, PUB. 1-10-2012. INT. CL. 41.

DOUBLEWIDE PARTNERS I, LLC, RICHARDSON, TX:
4,119,405, INT. CL. 36.

DOVER SADDLERY, INC., LITTLETON, MA:
4,117,809, PUB. 1-10-2012. INT. CL. 18.

DOWER CONSULTING, INC., ATLANTA, GA:
2,876,665, CANC. INT. CL. 35.

DOWN ETC, SAN FRANCISCO, CA:
4,117,212, PUB. 1-10-2012. INT. CL. 20.

DOYLE MUESER LTD., NEW YORK, NY, DBA DOYLE
MUESER LTD.:
4,118,618, PUB. 1-10-2012. INT. CL. 25.

DPE LABEL HOLDING CORP., BROOKLYN, NY:
4,119,458, INT. CL. 16.

DR. GOOD CARBS, INC., SOLON, OH:
4,119,774, INT. CL. 5.

DR. JEAN BAUSCH GMBH & CO. KG, 50769 COLOGNE,
FED REP GERMANY:
1,197,636. REN. 2-22-12. INT. CL. 5.

DR. JIMENEZ ALFONSO, EWA BEACH, HI:
4,117,259, PUB. 1-10-2012. MULTIPLE CLASS, INT. CLS. 9
AND 38.

DR. XAVIER AMADOR, PECONIC, NY:
4,117,203, PUB. 1-10-2012. INT. CL. 41.

DREAMWELL, LTD., LAS VEGAS, NV:
4,119,041, INT. CL. 20.

DROPSA S.P.A., MILAN, ITALY, DROPSA S.P.A., MILAN,
ITALY:
1,654,714. REN. 2-22-12. MULTIPLE CLASS, INT. CLS. 6,
7 AND 9.

DS-IQ, INC., BELLEVUE, WA:
2,467,857, CANC. INT. CL. 35.

DSC SALES, INC., OLDSMAR, FL:
4,117,374, PUB. 8-9-2011. MULTIPLE CLASS, INT. CLS.
18, 24 AND 25.

DUCE CONSTRUCTION CORPORATION, NEW YORK, NY:
4,119,085, INT. CL. 37.

DUCKLOW, CHARLES, LEES SUMMIT, MO:
4,117,088, PUB. 1-10-2012. INT. CL. 40.

DUMESTE, CEDEX 2, FRANCE:
2,965,576, CANC. MULTIPLE CLASS, INT. CLS. 20, 24
AND 27.

DUQUESNE UNIVERSITY OF THE HOLY GHOST, PITTS-
BURGH, PA:
3,040,336, CANC. INT. CL. 25.

DURAFLEAME, INC., STOCKTON, CA:
2,526,304. REN. 2-23-12. INT. CL. 4.

DURASAFE INCORPORATED, NEW BERLIN, WI:
2,682,707. REN. 2-23-12. MULTIPLE CLASS, INT. CLS. 6
AND 12.

DURO-LAST, INC., SAGINAW, MI:
4,119,356, INT. CL. 19.

DURR SYSTEMS, INC., PLYMOUTH, MI:
2,538,817. REN. 2-21-12. MULTIPLE CLASS, INT. CLS. 7,
11 AND 42.

DWYER INSTRUMENTS, INC., MICHIGAN CITY, IN:
942,339. REN. 2-17-12. U.S. CL. 26 (INT. CL. 9).

DWYER, FRANCES L., METAIRIE, LA:
2,967,919, CANC. INT. CL. 18.

DYK AUTOMOTIVE, LLC, GERMANTOWN, TN:
4,117,240, PUB. 1-10-2012. INT. CL. 35.

DYLAN KWASNIEWSKI IP HOLDING CO., LLC, LAS
VEGAS, NV:
4,118,266, PUB. 1-10-2012. INT. CL. 41.

DYMATIZE ENTERPRISES, LLC, FARMERS BRANCH, TX:
4,117,731, PUB. 1-10-2012. INT. CL. 5.

DYNAMIC ADSORBENTS, INC., NORCROSS, GA:
4,116,970, PUB. 1-10-2012. INT. CL. 10.
4,116,971, PUB. 1-10-2012. INT. CL. 10.

DYNAMIC RESEARCH AND SOLUTIONS, INC., BASKING
RIDGE, NJ:
2,966,148, CANC. INT. CL. 35.

DYSTAR COLOURS DISTRIBUTION GMBH, 65926 FRANK-
FURT, FED REP GERMANY:
4,119,284, INT. CL. 2.

D3 SITE INC., BROOKLYN, NY, DBA NÜCHA:
4,118,416, PUB. 1-10-2012. INT. CL. 30.

D4D TECHNOLOGIES, LLC, RICHARDSON, TX:
4,119,037, INT. CL. 9.

E & M CAPITAL DISTRIBUTORS, LLC, LANDOVER, MD:
4,119,036, MULTIPLE CLASS, INT. CLS. 29 AND 30.

E ENTERPRISES, INC., TAMPA, FL:
2,968,259, CANC. MULTIPLE CLASS, INT. CLS. 29 AND
30.

E. & J. GALLO WINERY, MODESTO, CA:
2,968,082, CANC. INT. CL. 33.

E. D. BULLARD COMPANY, CYNTHIANA, KY:
2,968,302, CANC. MULTIPLE CLASS, INT. CLS. 9 AND
25.

E. L. HATTON SALES CO., WELLINGTON, OH:
4,117,574, PUB. 1-10-2012. INT. CL. 17.

E.K. SUCCESS, LTD., CLIFTON, NJ:
3,934,862, COR. MULTIPLE CLASS, INT. CLS. 8, 14, 16,
20, 26 AND 41.

E.M. MANAGEMENT CO., L.L.C., LAKE ORION, MI AND
LAS VEGAS GOLF MARKETING, INC., HENDERSON,
NV:
2,967,892, CANC. INT. CL. 41.

EADOPT, LLC, DAVIDSON, NC:
4,119,841, INT. CL. 42.

- EARHUGGER, INC., LINDON, UT:
2,968,177, CANC. INT. CL. 9.
- EARL RENNISON, MENLO PARK, CA:
4,118,817, INT. CL. 9.
- EARTH TURNS, LLC, CANTON, CT:
4,118,852, MULTIPLE CLASS, INT. CLS. 3 AND 5.
- EARTHGREEN PRODUCTS, INC., DALLAS, TX:
2,543,469, REN. 2-23-12, INT. CL. 1.
- EARTHSAVE INTERNATIONAL, CHATSWORTH, CA:
2,840,394, CANC. INT. CL. 16.
- EASII IC, F-38036 GRENOBLE CEDEX 2, FRANCE:
4,116,815, PUB. 1-10-2012, MULTIPLE CLASS, INT. CLS. 9, 16 AND 42.
- EAST COAST WINGS CORPORATION, WINSTON-SALEM, NC:
4,117,436, PUB. 1-10-2012, INT. CL. 43.
4,117,441, PUB. 1-10-2012, INT. CL. 43.
- EAST WEST CONNECTION, INC., PITTSBURY, NJ:
2,538,957, REN. 2-19-12, MULTIPLE CLASS, INT. CLS. 41 AND 42.
- EAST WEST DISTRIBUTORS, INC., SCOTTSDALE, AZ:
2,967,373, CANC. INT. CL. 5.
- EASTERN DRILLER MANUFACTURING CO., INC., CO-LUMBIA, PA:
1,669,159, REN. 2-22-12, INT. CL. 7.
- EASTERN NATIONWIDE SUPPLY, INC., NEW YORK, NY:
4,117,608, PUB. 1-10-2012, INT. CL. 14.
- EASTERN SHORE NURSERY OF VIRGINIA, LLC, KELLER, VA:
4,119,302, MULTIPLE CLASS, INT. CLS. 31 AND 44.
- EASTERN TORCH INTERNATIONAL CO., LTD., TAI-CHUNG CITY, TAIWAN:
2,556,052, REN. 2-21-12, INT. CL. 12.
- EASTMAN KODAK COMPANY, ROCHESTER, NY:
4,118,811, INT. CL. 7.
- EASTWOOD, TRACY, LINCOLN, CA, DBA VERAISON HOLDINGS:
4,117,624, PUB. 1-10-2012, INT. CL. 35.
- EASY CAFFE, INC., PHOENIX, AZ:
2,968,440, CANC. INT. CL. 30.
- EASY ESPANOL, INC., NEW YORK, NY:
4,117,515, PUB. 1-10-2012, INT. CL. 41.
- EASY HEAT, INC., NEW CARLISLE, IN:
2,638,889, REN. 2-23-12, INT. CL. 11.
- EASYTURF, INC., VISTA, CA:
4,117,248, PUB. 1-10-2012, INT. CL. 27.
- EATON HYDRAULICS LLC, CLEVELAND, OH, VICKERS INCORPORATED, DETROIT, MI:
551,076, REN. 2-22-12, U.S. CL. 13 (INT. CL. 7).
- EBRARY, PALO ALTO, CA:
2,541,016, REN. 2-19-12, INT. CL. 42.
- EBSCO INDUSTRIES, INC., BIRMINGHAM, AL:
2,467,549, CANC. INT. CL. 16.
- EBYLINE, INC., SANTA CLARITA, CA:
4,119,822, INT. CL. 35.
- ECO GROUP ASIA LTD, CENTRAL, HONG KONG:
4,117,378, PUB. 1-10-2012, MULTIPLE CLASS, INT. CLS. 9 AND 11.
- ECO INNOCENCE, INC., LAS VEGAS, NV:
4,118,840, MULTIPLE CLASS, INT. CLS. 24 AND 25.
- ECO SCRAPS, LLC, PROVO, UT:
4,117,778, PUB. 1-10-2012, INT. CL. 1.
4,117,813, PUB. 1-10-2012, INT. CL. 1.
- ECOCLEAN CORPORATION, RANDALLSTOWN, MD, DBA NAEL COCE:
4,119,688, INT. CL. 25.
- ECOLAB INC., ST. PAUL, MN:
2,468,043, CANC. MULTIPLE CLASS, INT. CLS. 21 AND 37.
- ECONUGENICS, INC., SANTA ROSA, CA:
2,543,023, REN. 2-19-12, MULTIPLE CLASS, INT. CLS. 35 AND 42.
2,663,251, REN. 2-21-12, MULTIPLE CLASS, INT. CLS. 9 AND 16.
- ECOSCIENCE CORPORATION, RALEIGH, NC:
2,467,689, CANC. INT. CL. 42.
- ED AIR, INC., FONTANA, CA:
2,967,322, CANC. INT. CL. 39.
- EDDY, MICHAEL S, ORMOND BEACH, FL:
4,117,682, PUB. 1-10-2012, INT. CL. 16.
- EDIBLE SUPPLY, WALNUT, CA:
4,117,303, PUB. 1-10-2012, INT. CL. 9.
- EDICATE BUTTON & GARMENT ACCESSORIES, MFY, LTD., KWAI CHEONG, N.T., HONG KONG:
2,968,631, CANC. INT. CL. 26.
- EDIRECT, INC., DALLAS, TX, IMOCO, INC., IRVING, TX:
1,672,865, REN. 2-22-12, INT. CL. 42.
- EDISH, INC., SALT LAKE CITY, UT:
2,467,077, CANC. INT. CL. 35.
- EDNOVO, PALO ALTO, CA:
4,117,473, PUB. 1-10-2012, INT. CL. 41.
- EDUCATIONAL COMMUNICATIONS, INC., AUSTIN, TX:
2,968,421, CANC. INT. CL. 16.
- EDUCOM INC., ASHMORE, AUSTRALIA:
2,466,970, CANC. INT. CL. 16.
- EDULAUNCHPAD.COM, L.L.C., DAVENPORT, IA:
4,117,079, PUB. 1-10-2012, MULTIPLE CLASS, INT. CLS. 36 AND 41.
4,117,080, PUB. 1-10-2012, MULTIPLE CLASS, INT. CLS. 36 AND 41.
- EDWARDS, JUDY A, ANTIOCH, TN:
4,117,829, PUB. 1-10-2012, INT. CL. 41.
- EF COMPOSITE TECHNOLOGIES, L.P., CARLSBAD, CA:
4,117,915, PUB. 1-10-2012, INT. CL. 28.
- EFUEGO CORP., EUGENE, OR:
4,118,310, PUB. 1-10-2012, INT. CL. 28.
4,118,311, PUB. 1-10-2012, INT. CL. 12.
- EFX MARKETING LLC, BROOKLYN, NY:
2,968,268, CANC. INT. CL. 24.
- EGGER, CHRISTIAN R., MARSHFIELD, WI:
2,967,323, CANC. INT. CL. 16.
- EGYPTIAN LACQUER MANUFACTURING COMPANY, THE, FRANKLIN, TN:
936,452, REN. 2-22-12, U.S. CL. 16 (INT. CL. 2).
- EHARMONY, INC., SANTA MONICA, CA:
4,119,123, MULTIPLE CLASS, INT. CLS. 42 AND 45.
- ELECTRIC MOBILITY CORPORATION, SEWELL, NJ:
2,467,600, CANC. INT. CL. 16.
- ELECTRONIC ARTS INC., REDWOOD CITY, CA:
2,968,812, CANC. INT. CL. 41.
- ELEPHANT ENERGY, INC., DENVER, CO:
4,117,187, PUB. 1-10-2012, INT. CL. 35.
- ELEVATOR SAFETY COMPANY, OWINGS MILLS, MD, AKA ELSCO:
4,118,566, PUB. 1-10-2012, INT. CL. 7.
- ELIAS, NATIVIDAD R., MIAMI, FL:
4,119,175, INT. CL. 5.
- ELLIOTT, DOUGLAS R., ST. LOUIS, MO AND MATTHEWS, F. MAURY, ST. LOUIS, MO:
2,468,235, CANC. INT. CL. 36.
- ELLIS, J. NIGEL, WILMINGTON, DE:
2,537,142, REN. 2-19-12, INT. CL. 6.
- ELMHURST DAIRY, INC., JAMAICA, NY:
2,968,107, CANC. INT. CL. 29.
- ELSEVIER INC., NEW YORK, NY, YEAR BOOK MEDICAL PUBLISHERS, INC., CHICAGO, IL:
1,198,720, REN. 2-23-12, INT. CL. 16.
- EM.TV & MERCHANDISING AG, 85774 UNTERFOHRING, FED REP GERMANY:
2,965,452, CANC. MULTIPLE CLASS, INT. CLS. 3, 5, 8, 9, 11, 14, 15, 16, 18, 20, 21, 24, 25, 27, 28, 29, 30, 32, 35, 41 AND 42.
- EMANUELE, RICHARD, COLTS NECK, NJ:
4,117,306, PUB. 1-10-2012, INT. CL. 30.
- EMBRAER - EMPRESA BRASILEIRA DE AERONÁUTICA S.A., SAN JOSE DOS CAMPOS, BRAZIL:
4,116,671, PUB. 1-10-2012, INT. CL. 12.
4,116,672, PUB. 1-10-2012, INT. CL. 12.
- EMBRASE BUSINESS CONSULTING INC., WESTMOUNT, QUEBEC, CANADA:
4,119,802, INT. CL. 35.
- EMERGENCY ESSENTIALS, INC, OREM, UT:
2,468,577, CANC. INT. CL. 29.
- EMERGING LEGACIES LLC, GREENWOOD, SC:
4,118,504, PUB. 1-10-2012, INT. CL. 41.

EMERGINGWEALTH INVESTMENT MANAGEMENT, INC., PITTSBURGH, PA:
4,116,568, PUB. 1-10-2012. INT. CL. 36.

EMERSON POWER TRANSMISSION CORPORATION, FLORENCE, KY:
556,998, REN. 2-23-12. U.S. CL. 23 (INT. CL. 7).

EMERY OLEOCHEMICALS GMBH, FED REP GERMANY:
4,116,704, PUB. 1-10-2012. MULTIPLE CLASS, INT. CLS. 1, 2, 3, 4, 5, 19, 29, 30 AND 31.

EMERY, BRETT M., BATH, MI, DBA EMERY INFO-ENGINEERING:
2,968,542, CANC. INT. CL. 9.

EMMA T., L.L.C., CHATHAM, NJ:
2,968,158, CANC. MULTIPLE CLASS, INT. CLS. 25 AND 35.

EMMIS PUBLISHING LP, INDIANAPOLIS, IN:
2,468,164, CANC. INT. CL. 16.

EMMIS RADIO, LLC, INDIANAPOLIS, IN:
4,118,159, PUB. 1-10-2012. INT. CL. 35.

EMPERORS GROUP, LLC, ASHLAND, OR:
4,118,167, PUB. 1-10-2012. INT. CL. 41.

EMPLOYMENT LEARNING INNOVATIONS, INC., ATLANTA, GA:
2,968,555, CANC. MULTIPLE CLASS, INT. CLS. 9, 16 AND 41.

EMURGENTCARE, PLLC, WEST COXSACKIE, NY:
4,117,620, PUB. 1-10-2012. INT. CL. 44.

EMUSE CORPORATION, DUBLIN 2, IRELAND:
2,968,558, CANC. INT. CL. 9.

EM4, INC., BEDFORD, MA:
2,968,006, CANC. INT. CL. 9.

EN-VISION AMERICA, INC., NORMAL, IL:
2,467,022, CANC. INT. CL. 9.

ENAYET PATEL, UNITED KINGDOM:
4,116,826, PUB. 1-10-2012. MULTIPLE CLASS, INT. CLS. 6, 9, 18 AND 25.

ENDEAVOUR WINES PTY LTD., ABBOTSFORD, VICTORIA, AUSTRALIA:
3,116,637, CANC. INT. CL. 33.

ENDOSCOPIC TECHNOLOGIES, INC., RAMON, CA:
2,539,354, REN. 2-22-12. INT. CL. 10.

ENERGREEN AS, NORWAY:
4,116,841, PUB. 1-10-2012. MULTIPLE CLASS, INT. CLS. 7 AND 11.

ENERGY RELEASE, LLC, LEOMINSTER, MA:
4,116,564, PUB. 10-4-2011. MULTIPLE CLASS, INT. CLS. 2 AND 3.
4,116,565, PUB. 10-4-2011. MULTIPLE CLASS, INT. CLS. 2 AND 3.

ENERNET, INC. DBA ENERPATH, REDLANDS, CA:
4,118,435, PUB. 1-10-2012. INT. CL. 9.

ENGINE PARTS WAREHOUSE, INC., LOUISVILLE, KY:
2,569,513, REN. 2-23-12. INT. CL. 7.

ENGINE 2 FOR LIFE LLC, AUSTIN, TX:
4,118,477, PUB. 1-10-2012. MULTIPLE CLASS, INT. CLS. 41 AND 44.

ENGINE, LLC, GLEN ELLYN, IL:
4,119,207, MULTIPLE CLASS, INT. CLS. 35 AND 45.

ENGINEERED ARRESTING SYSTEMS CORPORATION, LOGAN TOWNSHIP, NJ:
4,119,757, INT. CL. 7.

ENGINEERED SYNTACTIC SYSTEMS, LLC, ATTLEBORO, MA:
4,116,925, PUB. 1-10-2012. INT. CL. 17.

ENGINEERING FITNESS INTERNATIONAL CORP., SAN DIEGO, CA, DBA TOTAL GYM, DBA EFI, AND DBA EFI MEDICAL SYSTEMS:
2,967,701, CANC. INT. CL. 28.

ENHANSOME INTERNATIONAL, INC., BURTONSVILLE, MD:
2,967,989, CANC. INT. CL. 25.

ENK INTERNATIONAL, LLC, NEW YORK, NY:
4,119,497, INT. CL. 35.

ENLACE GUATEMALA, INC., CHICAGO, IL:
4,117,120, PUB. 1-10-2012. INT. CL. 16.

ENRICO DALLA PIAZZA, SCHNEISINGEN, AARGAU, SWITZERLAND:
2,968,023, CANC. MULTIPLE CLASS, INT. CLS. 8, 18, 21, 24, 25 AND 42.

ENSEMBLE REAL ESTATE SERVICES, INC., PHOENIX, AZ:
4,116,891, PUB. 1-10-2012. MULTIPLE CLASS, INT. CLS. 36 AND 37.

ENSWICO IP AG, SWITZERLAND:
4,116,741, PUB. 1-10-2012. MULTIPLE CLASS, INT. CLS. 3 AND 11.
4,116,742, PUB. 1-10-2012. MULTIPLE CLASS, INT. CLS. 3 AND 11.
4,116,743, PUB. 1-10-2012. INT. CL. 11.
4,116,744, PUB. 1-10-2012. INT. CL. 11.

ENTEGRIS, INC., CHASKA, MN:
2,968,802, CANC. INT. CL. 17.

ENTERPRISE HOLDINGS, INC., ST. LOUIS, MO:
4,119,617, INT. CL. 39.

ENVELOPE MANUFACTURERS ASSOCIATION FOUNDATION FOR PAPER-BASED COMMUNICATIONS, ALEXANDRIA, VA:
2,567,160, REN. 2-21-12. MULTIPLE CLASS, INT. CLS. 41 AND 42.

ENVIRONMENTAL REMEDIATION AND FINANCIAL SERVICES LLC, SEA GIRT, NJ:
4,117,399, PUB. 1-10-2012. INT. CL. 36.
4,117,400, PUB. 1-10-2012. INT. CL. 36.

ENVIRONMENTAL TECHNOLOGY, INC., SOUTH BEND, IN:
2,524,225, REN. 2-22-12. INT. CL. 9.

ENZYME DEVELOPMENT CORPORATION, NEW YORK, NY, WALLERSTEIN COMPANY, INC., NEW YORK, NY:
394,989, REN. 2-22-12. U.S. CL. 6 (INT. CL. 1).

EON BEVERAGE GROUP, INC., ROSWELL, GA:
2,967,849, CANC. INT. CL. 32.

EP FEDERAL CREDIT UNION, WASHINGTON, DC:
4,118,682, PUB. 1-10-2012. INT. CL. 36.

EP LOYA GROUP, LP, EL PASO, TX:
4,118,002, PUB. 1-10-2012. INT. CL. 36.

EP-CM PROJECT MANAGEMENT USA, LLC, LONG BEACH, CA:
4,119,783, INT. CL. 37.

EPISTREAM CONSULTING INC., OTTAWA, ONTARIO, CANADA:
2,968,315, CANC. INT. CL. 35.

EPIVAX, INC., PROVIDENCE, RI:
2,467,811, CANC. INT. CL. 42.

EPIVOZ CORPORATION, SAN FRANCISCO, CA:
4,117,783, PUB. 1-10-2012. MULTIPLE CLASS, INT. CLS. 35 AND 41.
4,118,696, PUB. 1-10-2012. INT. CL. 42.

EPOKE A/S, DENMARK:
4,116,787, PUB. 1-10-2012. MULTIPLE CLASS, INT. CLS. 7 AND 9.

EQUALITY FLORIDA, INC., ST. PETERSBURG, FL AND EQUALITY FLORIDA INSTITUTE, INC., ST. PETERSBURG, FL:
4,118,422, PUB. 1-10-2012. INT. CL. 35.
4,118,423, PUB. 1-10-2012. INT. CL. 35.

EQUES, LTD., CAPE ELIZABETH, ME, AKA EQUES.LTD:
2,968,613, CANC. MULTIPLE CLASS, INT. CLS. 18 AND 20.

EQUIPATRON, LLC, MILWAUKEE, WI:
4,119,496, INT. CL. 35.

EQUIPMENT TECHNOLOGY, LLC, OKLAHOMA CITY, OK:
2,582,150, REN. 2-22-12. INT. CL. 12.

EQUIRE INC., COLORADO SPRINGS, CO:
2,967,331, CANC. MULTIPLE CLASS, INT. CLS. 35, 39 AND 42.

EQUITY EVENTS GROUP, HALLETSVILLE, TX, DBA BIG GAME GEAR:
4,119,763, INT. CL. 35.

ERATECH AFR, LLC, SPRINGBORO, OH:
1,676,687, REN. 2-23-12. INT. CL. 11.

ERI ECONOMIC RESEARCH INSTITUTE, INC., REDMOND, WA:
2,631,777, REN. 2-22-12. INT. CL. 16.

ERIC FISHERMAN, INC., UPPER SADDLE RIVER, NJ:
4,117,274, PUB. 1-10-2012. INT. CL. 9.
4,117,275, PUB. 1-10-2012. INT. CL. 9.

- ERICK, MITCHELL, OCOEE, FL AND DRUCKER, MORRIS, WOODBURY, NY, DBA MORT DRUCKER:
2,967,748, CANC. INT. CL. 41.
- ERIK'S DELICAFE, INC., SANTA CRUZ, CA:
1,677,604, REN. 2-21-12. INT. CL. 16.
- ERIN SCOTT PHOTOGRAPHY LLC, WASHINGTON, DC:
4,118,107, PUB. 1-10-2012. INT. CL. 41.
- ERSA BESITZ GMBH & CO. KG, KREUZWERTHEIM, FED REP GERMANY:
2,550,391, REN. 2-22-12. MULTIPLE CLASS, INT. CLS. 9, 10 AND 11.
- ESA'S FOUNDATION, NEW YORK, NY:
2,552,075, REN. 2-17-12. INT. CL. 36.
- ESPINOSA DE LOS MONTEROS FLORES, FRANCISCO DANIEL, MADRID, SPAIN:
2,968,358, CANC. INT. CL. 35.
- ESPN, INC., BRISTOL, CT:
2,467,342, CANC. INT. CL. 41.
- ESPORTIA INTERNATIONAL LTD., DUARTE, CA:
2,560,929, REN. 2-23-12. INT. CL. 25.
- ESPRESSO SMITH INC., COMMERCE CITY, CO:
4,118,109, PUB. 1-10-2012. MULTIPLE CLASS, INT. CLS. 30 AND 37.
- ESTABLECIMIENTO HUMBERTO CANALE S.A., CIUDAD DE BUENOS AIRES, ARGENTINA:
2,526,612, REN. 2-21-12. INT. CL. 33.
- ESTEE LAUDER INC., NEW YORK, NY:
2,967,522, CANC. INT. CL. 3.
- ESTES-COX CORP., PENROSE, CO:
2,967,519, CANC. INT. CL. 28.
- ETW INTERNATIONAL, CHICAGO, IL:
4,118,936, INT. CL. 42.
- EULIE LLC, PROVIDENCE, RI:
4,119,049, INT. CL. 25.
- EURO CARGO EXPRESS, INC., HAWTHORNE, NY:
4,118,689, PUB. 1-10-2012. MULTIPLE CLASS, INT. CLS. 35 AND 39.
- EURO-PRO OPERATING LLC, NEWTON, MA:
4,119,051, INT. CL. 7.
- EUROCOR GMBH, BONN, FED REP GERMANY:
4,116,997, PUB. 1-10-2012. MULTIPLE CLASS, INT. CLS. 10, 40 AND 42.
- EUROFRESH, INC., WILLCOX, AZ:
1,679,579, REN. 2-17-12. INT. CL. 31.
- EUROPESCA SPORT S.A.S., ITALY:
4,116,863, PUB. 1-10-2012. INT. CL. 9.
- EUROTEx IP HOLDINGS, SAN ANTONIO, TX:
4,117,864, PUB. 1-10-2012. INT. CL. 36.
- EUROTRADE (W) LIMITED, UNITED KINGDOM:
4,116,825, PUB. 1-10-2012. MULTIPLE CLASS, INT. CLS. 20, 21 AND 28.
- EVA GABOR INTERNATIONAL, LTD., KANSAS CITY, MO:
2,520,925, REN. 2-21-12. INT. CL. 26.
- EVANS CONSOLES CORPORATION, CALGARY, ALBERTA, CANADA:
3,039,941, CANC. INT. CL. 41.
- EVANS, ROBERT C., MERION STATION, PA:
1,674,863, REN. 2-17-12. MULTIPLE CLASS, INT. CLS. 9 AND 41.
- EVENING STANDARD LIMITED, KENSINGTON, LONDON, UNITED KINGDOM:
2,538,941, REN. 2-21-12. MULTIPLE CLASS, INT. CLS. 9 AND 35.
- EVEREADY BATTERY COMPANY, INC., ST. LOUIS, MO:
2,968,279, CANC. INT. CL. 11.
- EVEREST CAPITAL LLC, MIAMI, FL:
4,119,550, INT. CL. 36.
- EVEREST, MARK A., HARRISBURG, PA:
2,968,578, CANC. MULTIPLE CLASS, INT. CLS. 9, 16 AND 41.
- EVERSEALED WINDOWS, INC., EVERGREEN, CO:
4,119,319, INT. CL. 19.
- EVERY NEIGHBORHOOD PARTNERSHIP, FRESNO, CA:
4,118,007, PUB. 1-10-2012. INT. CL. 35.
- EVERYBODY LOVES KENNY PROJECT INC, PRINCETON, NJ:
4,117,124, PUB. 1-10-2012. MULTIPLE CLASS, INT. CLS. 35, 36, 41 AND 45.
- EVERYCHILD FOUNDATION, PACIFIC PALISADES, CA:
2,635,121, REN. 2-22-12. INT. CL. 36.
- EVERYDAY SHORTS INCORPORATED, CALGARY, ALBERTA, CANADA:
4,117,288, PUB. 1-10-2012. INT. CL. 3.
- EVERYTHING FOR LOVE, INC., PINE MOUNTAIN, CA:
2,968,048, CANC. INT. CL. 26.
- EVIDON, INC., NEW YORK, NY:
4,119,174, INT. CL. 9.
- EVONIK DEGUSSA GMBH, 45128 ESSEN, FED REP GERMANY:
2,539,691, REN. 2-21-12. INT. CL. 42.
2,539,692, REN. 2-21-12. INT. CL. 42.
- EVONIK DEGUSSA GMBH, FED REP GERMANY:
4,116,791, PUB. 1-10-2012. MULTIPLE CLASS, INT. CLS. 1 AND 3.
- EXACTEARTH LTD., CAMBRIDGE, ONTARIO, CANADA:
4,116,878, PUB. 1-10-2012. MULTIPLE CLASS, INT. CLS. 35, 38, 42 AND 45.
- EXCELSIOR ENTERPRISES, INC., ENGLEWOOD, CO:
1,219,463, REN. 2-22-12. INT. CL. 42.
- EXCELSIOR FOODS, INC., TORONTO, ON, CANADA, EXCELSIOR BRANDS LIMITED, DOWNSVIEW, ONTARIO, CANADA:
1,205,626, REN. 2-17-12. INT. CL. 30.
- EXECUTIVE SOUNDING BOARD ASSOCIATES, INC., PHILADELPHIA, PA:
1,691,935, REN. 2-23-12. INT. CL. 36.
- EXELINT INTERNATIONAL CO., LOS ANGELES, CA, DBA EXEL INTERNATIONAL:
2,662,774, REN. 2-21-12. INT. CL. 10.
- EXOMED AB, SE-191 44 SOLLENTUNA, SWEDEN:
4,116,842, PUB. 1-10-2012. INT. CL. 10.
- EXOTIC PARADISE CORPORATION, MIAMI, FL, DBA ZIK-ZOK:
2,520,339, REN. 2-21-12. INT. CL. 14.
- EXOUSA NUTRITION PRODUCTS, INC., LAS VEGAS, NV:
2,968,612, CANC. INT. CL. 5.
- EXPAND BEYOND CORPORATION, CHICAGO, IL:
2,967,516, CANC. INT. CL. 9.
- EXPEDIA, INC., BELLEVUE, WA:
4,119,483, INT. CL. 43.
4,119,484, INT. CL. 43.
- EXPEDITER ENTERPRISES CORP., PITTSBURGH, PA:
2,468,333, CANC. MULTIPLE CLASS, INT. CLS. 35 AND 42.
- EXPLORATORIUM, THE, SAN FRANCISCO, CA, PALACE OF ARTS AND SCIENCE, THE, SAN FRANCISCO, CA:
936,318, REN. 2-22-12. U.S. CL. 107 (INT. CL. 41).
- EXPLORE INFORMATION SERVICES, LLC, EAGAN, MN:
4,118,932, MULTIPLE CLASS, INT. CLS. 35, 36 AND 45.
- EXPORTALIZAS MEXICANAS SA DE CV, CULIACAN SINALOA, MEXICO:
4,119,626, INT. CL. 31.
- EXPRESS SERVICES, INC., OKLAHOMA CITY, OK:
2,467,555, CANC. INT. CL. 35.
- EXTREME ADHESIVES, INC., RAYMOND, NH:
4,117,881, PUB. 1-10-2012. INT. CL. 1.
- EXTREME ATHLETIC CORP., SUGAR LAND, TX:
2,967,324, CANC. INT. CL. 5.
- EYE CONSULTANTS OF TEXAS, P.A., GRAPEVINE, TX:
4,119,859, INT. CL. 44.
- EYECONCEPT LIMITED, KWUN TONG, KOWLOON, HONG KONG:
2,967,817, CANC. INT. CL. 9.
- EYEME, LLC, HOUSTON, TX:
4,119,472, INT. CL. 42.
- EYEWEAR DESIGNS, LTD., SYOSSET, NY:
2,967,947, CANC. INT. CL. 9.
- EZ VENT, LLC, CONOWINGO, MD:
4,117,825, PUB. 1-10-2012. INT. CL. 11.
- EID, LLC., BEND, OR:
4,119,433, INT. CL. 25.
- F.H. INC., CHARLOTTE, NC, DBA THE FIRE HOUSE CASUAL LIVING STORE:
1,676,228, REN. 2-17-12. INT. CL. 42.
- FACEBOOK, INC., MENLO PARK, CA:
4,119,056, MULTIPLE CLASS, INT. CLS. 35 AND 41.

FACTIVA, INC., MONMOUTH JUNCTION, NJ:
2,967,883, CANC. INT. CL. 38.

FAHSEL, SUSAN, NORTH BEND, WA:
2,968,458, CANC. INT. CL. 28.

FAIRFAX RADIOLOGICAL CONSULTANTS, P.C., FAIRFAX, VA:
4,117,298, PUB. 1-10-2012. INT. CL. 44.

FAIRFIELD INDUSTRIES INCORPORATED, SUGAR LAND, TX:
4,118,975, INT. CL. 9.

FAIRVIEW IMPORT CORPORATION, SANTA FE SPRINGS, CA:
4,118,581, PUB. 1-10-2012. INT. CL. 9.

FAIRWEATHER, ANDREA B., BROOKLYN, NY:
4,119,621, INT. CL. 16.

FAIRYGODMOTHER FOUNDATION, CHICAGO, IL:
2,471,533, CANC. INT. CL. 42.

FAMILIES OF SEPTEMBER 11, INC., NEW YORK, NY:
2,967,528, CANC. INT. CL. 42.

FAMILY MOTOR COACH ASSOCIATION, INC., CINCINNATI, OH:
4,119,256, INT. CL. 36.

FAMOUS BOARDING WAXES, LLC, LA JOLLA, CA:
2,967,732, CANC. INT. CL. 21.

FANATCHICKS GROUP, LLC, ORLANDO, FL:
4,117,507, PUB. 1-10-2012. INT. CL. 41.
4,117,510, PUB. 1-10-2012. INT. CL. 41.

FANCY FLOURS, INC., BOZEMAN, MT:
2,968,627, CANC. MULTIPLE CLASS, INT. CLS. 16, 21, 30 AND 35.

FANDANGO, LLC, LOS ANGELES, CA:
2,590,739, REN. 2-19-12. INT. CL. 41.

FANTASIA DISTRIBUTION, INC., ANAHEIM, CA:
4,117,279, PUB. 1-10-2012. INT. CL. 34.

FARMERS GROUP, INC., LOS ANGELES, CA:
2,649,247, REN. 2-23-12. INT. CL. 36.
2,649,248, REN. 2-23-12. INT. CL. 36.
4,119,540, MULTIPLE CLASS, INT. CLS. 18, 25, 28 AND 41.

FARNAM COMPANIES, INC., PHOENIX, AZ:
1,194,187, REN. 2-22-12. INT. CL. 5.

FARRINGTON, KIRK, SAN DIEGO, CA:
4,117,901, PUB. 1-10-2012. INT. CL. 41.

FASS CONSULTING, DAVIDSON, NC:
4,118,228, PUB. 1-10-2012. INT. CL. 41.

FASTENAL IP COMPANY, WINONA, MN:
726,883, REN. 2-22-12. U.S. CL. 13 (INT. CL. 6).

FASTNOTE, LLC, LEWES, DE:
4,118,117, PUB. 1-10-2012. MULTIPLE CLASS, INT. CLS. 38 AND 45.

FATS, INC., SUWANEE, GA:
2,967,753, CANC. INT. CL. 9.

FAUX LTD., GLASGOW, SCOTLAND UK, UNITED KINGDOM, TA FAUX LTD.:
4,117,329, PUB. 1-10-2012. INT. CL. 3.

FEARLESS MEDIA, LLC, NEW YORK, NY:
4,118,011, PUB. 1-10-2012. INT. CL. 35.

FEDERAL EXPRESS CORPORATION, MEMPHIS, TN:
4,119,092, MULTIPLE CLASS, INT. CLS. 35 AND 40.
4,119,577, INT. CL. 39.

FEDERAL SIGNAL CORPORATION, OAK BROOK, IL:
1,685,767, REN. 2-23-12. INT. CL. 9.

FEDERAL-MOGUL WORLD WIDE, INC., SOUTHFIELD, MI:
1,654,276, REN. 2-21-12. INT. CL. 12.

FEDERATED MDTA LLC, CAMBRIDGE, MA:
2,967,307, CANC. INT. CL. 36.

FEDERATED MUTUAL INSURANCE COMPANY, OWATONNA, MN:
4,119,271, MULTIPLE CLASS, INT. CLS. 35 AND 36.

FEDERATED TELEPHONE COOPERATIVE, CHOKIO, MN:
4,119,094, MULTIPLE CLASS, INT. CLS. 37, 38 AND 42.

FEDERATION OF RENTAL-HOUSING PROVIDERS OF ONTARIO, TORONTO, ONTARIO, CANADA:
4,116,942, PUB. 1-10-2012. INT. CL. 36.

FEED PROJECTS LLC, NEW YORK, NY:
4,118,792, INT. CL. 18.

FEED THE CHILDREN, INC., OKLAHOMA CITY, OK:
4,117,127, PUB. 1-10-2012. MULTIPLE CLASS, INT. CLS. 36, 41, 43 AND 44.

FEEES, TORI D., DES MOINES, IA:
4,119,584, INT. CL. 35.

FELDMAN, ROBERT D., BREMERTON, WA, DBA BREMELLO AND FELDMAN, BRITT, BREMERTON, WA, DBA BREMELLO:
4,119,835, INT. CL. 25.

FELIX SCHOELLER JR. FOTO UND SPEZIALPAPIERE GMBH & CO. KG, 49086 OSNABRÜCK, FED REP GERMANY:
4,116,820, PUB. 1-10-2012. INT. CL. 16.

FEMININE RASCAL INC., NEW YORK, NY:
4,119,711, INT. CL. 35.

FENTON AND ROSS AN ACCOUNTANCY CORP, LOS ANGELES, CA:
4,118,254, PUB. 1-10-2012. INT. CL. 36.

FERRARI IMPORTING COMPANY, PITTSBURGH, PA, DBA GAMMA SPORTS:
4,117,270, PUB. 1-10-2012. INT. CL. 28.

FERRICELLI INDUSTRIA E COMERCIO DE CALCADOS LTDA., SAO PAULO, BRAZIL:
2,968,326, CANC. INT. CL. 25.

FERROXCUBE INTERNATIONAL HOLDING, B.V., ROERMOND, NETHERLANDS, NORTH AMERICAN PHILIPS COMPANY, INC., DOBBS FERRY, NY:
545,060, REN. 2-17-12. U.S. CL. 21 (INT. CL. 9).

FERTRELL, BAINBRIDGE, PA:
4,116,562, PUB. 1-10-2012. INT. CL. 1.

FETTERS, CAROLYN, HUNTINGTON BEACH, CA:
4,117,961, PUB. 1-10-2012. INT. CL. 5.

FIBERIO TECHNOLOGY CORPORATION, MCALLEN, TX:
4,119,204, INT. CL. 7.
4,119,205, INT. CL. 7.

FIDIA S.P.A., I-10099 SAN MAURO TORINESE TO, ITALY:
4,116,790, PUB. 1-10-2012. INT. CL. 9.

FIEGER, FIEGER, KENNEY, JOHNSON & GIROUX, P.C., SOUTHFIELD, MI:
4,117,770, PUB. 1-10-2012. INT. CL. 45.

FIELD IV, GEORGE ADDISON, DALLAS, TX:
4,117,837, PUB. 1-10-2012. INT. CL. 42.

FIELD LOGIC, INC., SUPERIOR, WI:
2,539,993, REN. 2-22-12. INT. CL. 28.

FIFTH THIRD BANCORP, CINCINNATI, OH:
1,741,669, REN. 2-23-12. INT. CL. 36.

FIGUEROA, MELVIN, NEW YORK, NY:
4,119,535, INT. CL. 30.

FIGURE EIGHT ISLAND YACHT CLUB, INC., WILMINGTON, NC:
2,561,672, REN. 2-23-12. MULTIPLE CLASS, INT. CLS. 25 AND 41.

FILA LUXEMBOURG S.À.R.L., LUXEMBOURG, LUXEMBOURG:
4,118,632, PUB. 1-10-2012. INT. CL. 25.

FILESTREAM, INC., GLEN HEAD, NY, FILESTREAM, INC., GLEN HEAD, NY:
2,523,120, REN. 2-21-12. INT. CL. 9.

FILLMORE LC HOLDINGS I, LLC, DENVER, CO:
4,117,764, PUB. 1-10-2012. INT. CL. 43.
4,117,765, PUB. 1-10-2012. INT. CL. 43.

FILLMORE STREET BREWERY, LLC, OVERLAND, MO:
2,968,807, CANC. INT. CL. 32.

FINANCIAL INDUSTRIES CORPORATION, AUSTIN, TX:
2,466,942, CANC. INT. CL. 36.
2,466,943, CANC. INT. CL. 36.

FINANCIAL NETWORK GROUP, LTD., CINCINNATI, OH:
4,118,346, PUB. 1-10-2012. INT. CL. 36.

FINANCIAL TIMES LIMITED, THE, LONDON, UNITED KINGDOM:
4,117,042, PUB. 1-10-2012. MULTIPLE CLASS, INT. CLS. 35, 38 AND 41.

FINANZ ST. HONORE, B.V., 1097 JB AMSTERDAM, NETHERLANDS:
4,117,791, PUB. 1-10-2012. INT. CL. 3.

FINDLEY DAVIES, INC., TOLEDO, OH:
2,556,111, REN. 2-21-12. INT. CL. 36.

- FINE PAINTS OF EUROPE, INC., WOODSTOCK, VT:
2,885,999, CANC. INT. CL. 2.
- FIRARI, FAIRLIE, CAZENOVIA, NY:
4,119,106, INT. CL. 41.
- FIRE PLANNING ASSOCIATES, INC., WASHINGTON CROSSING, PA:
4,118,445, PUB. 1-10-2012. INT. CL. 9.
- FIREPIT FRIENDS, LLC, FORT COLLINS, CO, DBA CONFETTI COUTURE:
4,118,322, PUB. 1-10-2012. INT. CL. 16.
- FIRESTORM INVESTMENTS, INC., SPRING VALLEY, CA:
2,968,131, CANC. MULTIPLE CLASS, INT. CLS. 9, 10, 16 AND 41.
- FIRKIN HOSPITALITY GROUP INC., MARKHAM, CANADA:
2,967,325, CANC. INT. CL. 42.
- FIRST ACTION SECURITY TEAM, INC., HAGERSTOWN, MD:
4,117,330, PUB. 1-10-2012. INT. CL. 9.
- FIRST BUSINESS BROKERS LTD., COLORADO SPRINGS, CO:
1,674,507, REN. 2-22-12. INT. CL. 36.
- FIRST DATA RESOURCES, LLC, GREENWOOD VILLAGE, CO:
4,119,272, INT. CL. 45.
- FIRST MMT KABUSHIKI KAISHA, TOKYO-TO, JAPAN:
2,965,436, CANC. INT. CL. 25.
- FIRST NATIONAL BANK OF THE ROCKIES, MEEKER, CO:
2,467,091, CANC. INT. CL. 36.
- FIRST SECURITY CORPORATION, SALT LAKE CITY, UT:
1,643,862, CANC. INT. CL. 36.
1,649,005, CANC. INT. CL. 36.
- FISCHER, MICHAEL EDWARD, BRECKENRIDGE, CO:
4,117,292, PUB. 1-10-2012. INT. CL. 25.
- FISCHER, MR. BRETT, PHOENIX, AZ, AB DOLLY, LLC, WEST CHESTER, PA:
2,532,616, REN. 2-22-12. INT. CL. 28.
- FISERV, INC., BROOKFIELD, WI:
4,118,691, PUB. 1-10-2012. INT. CL. 42.
- FISH IN THE GARDEN, LLC, FALMOUTH, ME:
4,118,172, PUB. 1-10-2012. MULTIPLE CLASS, INT. CLS. 21 AND 35.
- FISHER SCIENTIFIC COMPANY L.L.C., PITTSBURGH, PA, FISHER SCIENTIFIC COMPANY, PITTSBURGH, PA:
1,184,823, REN. 2-22-12. INT. CL. 21.
- FISHING HAS NO BOUNDARIES, INC., HAYWARD, WI:
2,536,136, REN. 2-22-12. INT. CL. 41.
- FISHPOND, INC., SILVERTHORNE, CO:
2,541,219, REN. 2-21-12. INT. CL. 28.
- FISKEN, LYNDA MARLO, VIRGINIA BEACH, VA:
4,116,972, PUB. 1-10-2012. INT. CL. 16.
- FISKER AUTOMOTIVE, INC., ANAHEIM, CA:
4,118,804, INT. CL. 12.
- FIST PRODUCTIONS LTD., NEW YORK, NY:
4,117,869, PUB. 1-10-2012. INT. CL. 35.
- FIT FATALE LLC, PHOENIX, AZ:
4,118,546, PUB. 1-10-2012. INT. CL. 25.
- FITNESS EQUIPMENT MANUFACTURING, LLC, UXBRIDGE, MA:
4,118,313, PUB. 1-10-2012. INT. CL. 41.
- FITNESS PROPELLED LLC, SCOTTSDALE, AZ:
4,117,538, PUB. 1-10-2012. INT. CL. 41.
- FLACK, JEREMY, CLEVELAND, OH:
4,117,368, PUB. 1-10-2012. MULTIPLE CLASS, INT. CLS. 35 AND 40.
- FLANAGAN, LINDA M., SUDBURY, MA, DBA FLANABAGS:
4,117,736, PUB. 1-10-2012. INT. CL. 18.
- FLAT CREEK MOUNTAIN, INC., ASHEVILLE, NC:
4,118,862, INT. CL. 14.
- FLATWORLD SOLUTIONS INC., PRINCETON, NJ:
4,116,945, PUB. 1-10-2012. MULTIPLE CLASS, INT. CLS. 35 AND 42.
4,116,946, PUB. 1-10-2012. MULTIPLE CLASS, INT. CLS. 35, 40 AND 41.
- FLAVORX, INC., COLUMBIA, MD:
2,539,195, REN. 2-18-12. INT. CL. 42.
- FLETCHER LIMESTONE COMPANY, INC., FLETCHER, NC:
2,968,124, CANC. INT. CL. 1.
- FLEXA GMBH & CO. PRODUKTION UND VERTRIEB KG, D - 63456 HANAU, FED REP GERMANY:
2,526,437, REN. 2-23-12. MULTIPLE CLASS, INT. CLS. 6 AND 9.
- FLEXCUT TOOL COMPANY, INC, ERIE, PA:
4,118,142, PUB. 1-10-2012. INT. CL. 8.
4,118,170, PUB. 1-10-2012. INT. CL. 8.
- FLEXCUT TOOL COMPANY, INC., ERIE, PA:
4,117,991, PUB. 1-10-2012. INT. CL. 8.
4,118,171, PUB. 1-10-2012. INT. CL. 8.
- FLEXMASTER U.S.A., INC., HOUSTON, TX:
2,525,699, REN. 2-23-12. MULTIPLE CLASS, INT. CLS. 17 AND 19.
- FLIGHT SAFETY TECHNOLOGIES, INC., NEW LONDON, CT:
2,967,386, CANC. INT. CL. 9.
- FLIGHT SYSTEM CONSULTING, INC., SHIBUYA-KU, TOKYO, JAPAN:
4,117,430, PUB. 1-10-2012. MULTIPLE CLASS, INT. CLS. 9 AND 42.
- FLINDERS SURFING CO. PTY. LTD., ROSEBUD, VICTORIA, 3939, AUSTRALIA:
1,158,264, REN. 2-21-12. INT. CL. 28.
- FLIP 'N DIP, TALLMAN, NY:
4,117,923, PUB. 1-10-2012. INT. CL. 35.
- FLIP TECHNOLOGIES LIMITED, DANGAN, GALWAY, IRELAND:
4,116,590, PUB. 1-10-2012. INT. CL. 10.
- FLOATING LUXURIES INC., GAUTIER, MS:
4,117,596, PUB. 1-10-2012. INT. CL. 28.
- FLOATING LUXURIES, INC., GAUTIER, MS:
4,117,524, PUB. 1-10-2012. INT. CL. 28.
- FLOORCO ENTERPRISES, LLC, SHEPHERDSVILLE, KY:
4,118,753, INT. CL. 20.
- FLOORTECH INTERNATIONAL LIMITED, LITTLE ISLAND, CORK, IRELAND:
4,117,081, PUB. 1-10-2012. MULTIPLE CLASS, INT. CLS. 17, 19 AND 37.
- FLORIDA VANGUARD ATTORNEYS, LLC, TAMPA, FL:
4,118,506, PUB. 1-10-2012. INT. CL. 45.
- FLOWER TECH CTR INC, RAMSEY, NJ:
4,118,151, PUB. 1-10-2012. MULTIPLE CLASS, INT. CLS. 35 AND 39.
- FLUOR ENTERPRISES, INC., IRVING, TX:
4,119,096, MULTIPLE CLASS, INT. CLS. 37 AND 42.
4,119,097, MULTIPLE CLASS, INT. CLS. 37 AND 42.
4,119,098, MULTIPLE CLASS, INT. CLS. 37 AND 42.
- FLYING FROG PRODUCTIONS, LLC, LYNNWOOD, WA:
4,118,874, INT. CL. 28.
- FOAMAROMA LLC, CAMAS, WA:
4,119,618, INT. CL. 20.
- FOEDERO TECHNOLOGIES INC., PICKERING, ONTARIO L1V 1B5, CANADA:
2,965,449, CANC. MULTIPLE CLASS, INT. CLS. 9 AND 42.
- FOLKMANIS, INC., EMERYVILLE, CA:
4,119,391, INT. CL. 28.
- FONEGEAR, LLC, ROCHESTER HILLS, MI:
4,118,808, INT. CL. 9.
- FOODHANDLER, INC., RENO, NV:
4,117,684, PUB. 1-10-2012. INT. CL. 21.
4,119,642, MULTIPLE CLASS, INT. CLS. 9, 10 AND 21.
- FOODILY, INC., SAN MATEO, CA:
4,119,307, MULTIPLE CLASS, INT. CLS. 35, 41, 42 AND 43.
- FOOT EFX WHOLESALE FOOT CARE PRODUCTS, LLC, LAS VEGAS, NV:
2,967,869, CANC. INT. CL. 10.
- FOREST LABORATORIES, INC., NEW YORK, NY:
1,211,135, REN. 2-23-12. INT. CL. 1.
- FOREST MEDICAL PRODUCTS, INC., HILLSBORO, OR, DBA FOREST DENTAL PRODUCTS:
1,192,052, REN. 2-21-12. INT. CL. 10.
- FOREVER FAITH LLC, TULSA, OK:
4,118,259, PUB. 1-10-2012. INT. CL. 25.

FORGEHOUSE LLC, NORCROSS, GA:
2,968,165, CANC. INT. CL. 9.

FORTUGNO, JAMES, NEW CITY, NY:
4,119,446, INT. CL. 16.

FORTUNE PRODUCTS, INC., MARBLE FALLS, TX:
4,117,231, PUB. 1-10-2012. INT. CL. 8.

FOSTER & ADOPTIVE CARE COALITION, ST. LOUIS, MO:
4,119,517, INT. CL. 35.

FOSTER-GOODMAN, SUSAN, STEVENSON RANCH, CA:
4,118,485, PUB. 1-10-2012. INT. CL. 30.

FOSTER, KATHRYN, STUDIO CITY, CA:
4,119,567, INT. CL. 30.

FOUNDERS ENTERTAINMENT, LLC, NEW YORK, NY:
4,117,152, PUB. 1-10-2012. MULTIPLE CLASS, INT. CLS.
35 AND 41.
4,117,154, PUB. 1-10-2012. MULTIPLE CLASS, INT. CLS.
35 AND 41.

FOUNTAIN, BOB, LARGO, FL, DBA PRECISION IMAGES,
LLC:
4,116,968, PUB. 1-10-2012. INT. CL. 25.

FOUR CORNERS MOBILE MEDIA, LLC, DAYTONA
BEACH, FL:
4,118,056, PUB. 1-10-2012. INT. CL. 35.

FOUR WINDS PERFORMANCE INC., OTTAWA, ONTARIO,
CANADA:
4,117,139, PUB. 1-10-2012. INT. CL. 41.

FOWLER, STEVEN W, RIDGELAND, MS, DBA A COMPU-
TER MD, INC:
4,117,832, PUB. 1-10-2012. INT. CL. 37.

FOX, MARY D., SAN CRISTOBAL, NM:
2,582,354. REN. 2-21-12. INT. CL. 5.

FOXLAND INTERNATIONAL, LTD., NEW YORK, NY:
1,161,042. REN. 2-22-12. INT. CL. 25.

FOXY FEATHERS, LLC, DENVER, CO:
4,117,964, PUB. 1-10-2012. MULTIPLE CLASS, INT. CLS.
14 AND 26.

FOXY SHAZAM, LLC, RAMSEY, NJ:
4,118,501, PUB. 1-10-2012. INT. CL. 41.

FPX, LLC, DALLAS, TX:
2,968,557, CANC. MULTIPLE CLASS, INT. CLS. 9 AND
42.

FRANCHISE RECORDS, INC., NEW YORK, NY, DBA
FRANCHISE MARKETING:
2,967,691, CANC. INT. CL. 9.
2,967,692, CANC. INT. CL. 28.

FRANCO HARRIS, PITTSBURGH, PA:
4,118,499, PUB. 1-10-2012. INT. CL. 20.

FRANK BRUNCKHORST CO., L.L.C., BROOKLYN, NY:
4,116,939, PUB. 1-10-2012. INT. CL. 29.
4,116,940, PUB. 1-10-2012. INT. CL. 29.

FRANK NASTO III, MATAWAN, NJ:
4,118,025, PUB. 1-10-2012. INT. CL. 30.
4,118,028, PUB. 1-10-2012. INT. CL. 30.

FRANK ROBERSON - PHYSIQUE SPECIALIST CENTER,
HOUSTON, TX:
4,117,480, PUB. 1-10-2012. INT. CL. 41.

FRANK RUSSELL COMPANY, SEATTLE, WA:
4,118,785, MULTIPLE CLASS, INT. CLS. 9 AND 36.

FRATELLI FANTINI S.P.A., 28010 PELLA NO, ITALY:
4,118,824, INT. CL. 30.

FRED MEYER STORES, INC., PORTLAND, OR:
1,749,082. REN. 2-22-12. INT. CL. 42.

FRED SOLL'S INCENSE & ETC., TIJERAS, NM:
2,544,817. REN. 2-17-12. INT. CL. 3.

FREDERICK WARNE & CO., INC., NEW YORK, NY:
1,168,541. REN. 2-22-12. INT. CL. 28.

FREED'S BAKERY, LLC, MANCHESTER, NH:
4,117,470, PUB. 1-10-2012. INT. CL. 30.

FREESCALE SEMICONDUCTOR, INC., AUSTIN, TX:
2,967,379, CANC. INT. CL. 9.

FREESLATE, INC., SUNNYVALE, CA:
2,530,720. REN. 2-22-12. INT. CL. 9.

FREIGHT SAFETY, LLC, SMITHTON, PA:
2,967,796, CANC. INT. CL. 45.

FREIGHTDEPOT.COM, INC., WHITTIER, CA:
2,967,346, CANC. INT. CL. 39.

FREMANTLEMEDIA LIMITED, LONDON, ENGLAND
AND SIMCO LIMITED, LONDON, ENGLAND:
4,117,464, PUB. 1-10-2012. INT. CL. 3.
4,117,465, PUB. 1-10-2012. INT. CL. 14.
4,117,466, PUB. 1-10-2012. INT. CL. 25.

FRENCH MARKET CORPORATION, NEW ORLEANS, LA:
4,116,890, PUB. 1-10-2012. INT. CL. 36.

FREQUENCY SPECIFIC SEMINARS, INC., VANCOUVER,
WA:
4,118,182, PUB. 1-10-2012. INT. CL. 41.

FRESH EXPRESS INCORPORATED, SALINAS, CA:
4,119,720, INT. CL. 29.

FRESH YOGA, LLC., NEW HAVEN, CT:
2,967,873, CANC. INT. CL. 41.

FRESH, INC., NEW YORK, NY TO FRESH, INC., NEW
YORK, NY:
2,537,616, AM. INT. CL. 3.

FRONTERA FOODS, INC., CHICAGO, IL:
2,547,780. REN. 2-19-12. INT. CL. 30.

FRONTIER COMMUNICATIONS CORPORATION, STAM-
FORD, CT:
4,117,328, PUB. 1-10-2012. MULTIPLE CLASS, INT. CLS.
41 AND 42.
4,117,520, PUB. 1-10-2012. INT. CL. 35.

FROST CUTLERY COMPANY LLC, OOLTEWAH, TN:
4,117,019, PUB. 1-10-2012. INT. CL. 8.

FRUTAROM NETHERLANDS B.V., NL-3905 PE VEENEN-
DAAL, NETHERLANDS:
4,116,762, PUB. 1-10-2012. MULTIPLE CLASS, INT. CLS. 5
AND 29.

FRX SOFTWARE CORPORATION, DENVER, CO:
2,967,368, CANC. INT. CL. 9.

FRY'S ELECTRONICS, INC., SAN JOSE, CA:
4,116,665, PUB. 1-10-2012. MULTIPLE CLASS, INT. CLS.
36 AND 41.

FSI INTERNATIONAL, INC., CHASKA, MN:
1,696,899. REN. 2-21-12. INT. CL. 11.

FTW GROUP, OAKLAND, CA:
4,118,158, PUB. 1-10-2012. INT. CL. 35.

FUENTE MARKETING LTD., PROVIDENCIALES, TURKS/
CAICOS IS.:
2,528,506. REN. 2-22-12. INT. CL. 25.

FUGRO SEISMIC IMAGING, INC., HOUSTON, TX:
2,603,709. REN. 2-22-12. MULTIPLE CLASS, INT. CLS. 35
AND 42.

FUJITSU MICROELECTRONICS AMERICA, INC., SAN
JOSE, CA:
2,967,534, CANC. INT. CL. 9.

FULL CHANNEL TV, INC., WARREN, RI, DBA FULL
CHANNEL:
4,117,732, PUB. 1-10-2012. INT. CL. 38.

FULL SAIL, LLC, WINTER PARK, FL:
4,117,929, PUB. 1-10-2012. INT. CL. 25.
4,118,794, INT. CL. 41.

FULLER INSURANCE AGENCY, CHINO HILLS, CA:
4,117,290, PUB. 1-10-2012. INT. CL. 36.

FUNDEX GAMES, LTD., INDIANAPOLIS, IN:
4,118,715, PUB. 1-10-2012. INT. CL. 28.
4,118,716, PUB. 1-10-2012. INT. CL. 28.

FUNK, FRANK J., CAMPBELL, CA:
2,968,637, CANC. INT. CL. 5.

FUNNY2, INC., SAN DIEGO, CA:
4,118,420, PUB. 1-10-2012. INT. CL. 42.

FUNUYUIOZ PRODUCTION AB, SWEDEN:
4,116,722, PUB. 1-10-2012. INT. CL. 41.

FURRIER, JOE, ROSEVILLE, CA:
4,117,341, PUB. 1-10-2012. INT. CL. 25.

FUSE NETWORKS LLC, JERICHO, NY:
2,968,605, CANC. INT. CL. 41.

FUSIONBRANDS INC, NAPLES, NY:
4,117,361, PUB. 1-10-2012. INT. CL. 21.

FUZE BEVERAGE, LLC, ENGLEWOOD CLIFFS, NJ:
2,968,230, CANC. INT. CL. 32.

G.A.W. INDUSTRIES, INC., LATHROP, CA:
4,118,384, PUB. 1-10-2012. INT. CL. 12.

G.S. HARRIS CO., INC., OGDEN, UT:
4,119,836, INT. CL. 19.

- GAI MATTIOLO HOLDING S.A., LUXEMBOURG, LUXEMBOURG:
2,467,717, CANC. INT. CL. 3.
- GAKM RESOURCES CORPORATION, NEW YORK, NY:
2,525,702, REN. 2-22-12. INT. CL. 25.
- GALIAM HOLDINGS, LLC, SAN FRANCISCO, CA:
4,119,500, INT. CL. 36.
- GALLERY BLOCKS, LLC, OWINGS MILLS, MD:
4,118,511, PUB. 1-10-2012. MULTIPLE CLASS, INT. CLS. 16 AND 40.
- GALLINA, HUNT, GERMANTOWN, TN:
4,118,860, INT. CL. 5.
- GALT INVESTMENT MANAGEMENT LLC, BOSTON, MA:
4,117,626, PUB. 1-10-2012. INT. CL. 36.
- GAMARRA, RICK, LONG BEACH, CA:
2,762,712, CANC. INT. CL. 33.
- GAMBRO LUNDIA AB, 22643 LUND, SWEDEN, FORMERLY GAMBRO AB:
2,550,804, REN. 2-19-12. INT. CL. 10.
- GAMBRO LUNDIA AB, 22643 LUND, SWEDEN:
2,550,805, REN. 2-19-12. INT. CL. 5.
- GAMBRO LUNDIA AB, 22643 LUND, SWEDEN, FORMERLY GAMBRO AB:
2,553,625, REN. 2-19-12. INT. CL. 5.
- GAMBRO LUNDIA AB, 22643 LUND, SWEDEN:
2,553,626, REN. 2-19-12. INT. CL. 10.
- GAMERESORT LLC, BOULDER, CO:
4,118,417, PUB. 1-10-2012. INT. CL. 9.
- GAMES WORKSHOP LIMITED, NOTTINGHAM, UNITED KINGDOM:
4,118,819, INT. CL. 16.
- GAMESTOP, INC., GRAPEVINE, TX:
4,117,015, PUB. 1-10-2012. INT. CL. 35.
- GAMMA MEDICA-IDEAS, INC., NORTHRIDGE, CA:
4,119,402, INT. CL. 10.
- GANDY, CHRIS L, EL DORADO HILLS, CA AND GANDY, AUDREY E, EL DORADO HILLS, CA:
2,967,539, CANC. INT. CL. 25.
- GANIMIAN; SAMMY E., FRESNO, CA, DBA HYE QUALITY BAKERY:
1,188,845, REN. 2-22-12. INT. CL. 30.
- GANSU BINHE FOODSTUFF INDUSTRY GROUP CO. LTD, GANSU PROVINCE, CHINA:
4,119,091, INT. CL. 33.
- GANZ, WOODBRIDGE, ONTARIO L4L 3T2, CANADA:
2,967,577, CANC. INT. CL. 21.
- GARDNER, BRIAN D, GREENSBURG, PA, DBA BDG CUSTOMS:
4,118,418, PUB. 1-10-2012. INT. CL. 40.
- GARDUS, INC., POWAY, CA:
4,119,347, INT. CL. 9.
4,119,348, INT. CL. 7.
- GAREB SHAMUS ENTERPRISES, INC., CONGERS, NY:
2,968,241, CANC. INT. CL. 16.
- GARICK, LLC, CLEVELAND, OH:
1,696,371, REN. 2-17-12. INT. CL. 31.
2,639,395, REN. 2-22-12. MULTIPLE CLASS, INT. CLS. 1 AND 31.
- GARST, ESTEL M., FOLSOM, CA, DBA URBAN DOG DESIGNS:
3,672,872, CANC. INT. CL. 18.
- GARVEY, RICHARD, MALIBU, CA:
2,460,936, REN. 2-23-12. MULTIPLE CLASS, INT. CLS. 9 AND 42.
2,460,936, CANC. INT. CL. 16.
- GATEWAY GAMING LLC, PIEDMONT, SC:
4,118,449, PUB. 1-10-2012. INT. CL. 9.
- GATOR CASES, INC., LUTZ, FL:
4,116,898, PUB. 1-10-2012. INT. CL. 9.
- GAY DAYS, INC., ORLANDO, FL:
4,117,601, PUB. 1-10-2012. INT. CL. 35.
- GCS DISTRIBUTION AND LICENSING, LLC, SUWANEE, GA:
4,119,849, INT. CL. 44.
- GE INTELLIGENT PLATFORMS, INC., CHARLOTTESVILLE, VA:
2,967,423, CANC. INT. CL. 9.
- GEARTRIBE CORP, ORINDA, CA:
4,119,245, INT. CL. 42.
- GEBRÜDER BUSATIS GESELLSCHAFT M.B.H., PURGSTALL, AUSTRIA:
4,117,442, PUB. 1-10-2012. INT. CL. 7.
- GEEZERJOCK MEDIA, INC., CHICAGO, IL:
2,968,064, CANC. INT. CL. 16.
- GEHAN HOMES, LTD., DALLAS, TX:
4,118,078, PUB. 1-10-2012. INT. CL. 37.
- GELERT LTD, UNITED KINGDOM:
4,116,703, PUB. 1-10-2012. MULTIPLE CLASS, INT. CLS. 8, 9, 11, 18, 20, 21, 22, 25 AND 35.
- GELHART, HEATHER STAR, NEWPORT BEACH, CA:
2,967,656, CANC. INT. CL. 16.
- GENAUDIO, INC., CENTENNIAL, CO:
4,016,178, COR. MULTIPLE CLASS, INT. CLS. 35 AND 41.
4,016,180, COR. MULTIPLE CLASS, INT. CLS. 35 AND 41.
- GENDRON, MARK J, SOMERSET, CA:
4,116,644, PUB. 7-20-2010. INT. CL. 33.
- GENDRON, MARK JAY, SOMERSET, CA:
4,116,639, PUB. 7-27-2010. INT. CL. 33.
- GENERA INTERACTIVE, S.L., 41018 SEVILLA, SPAIN:
4,116,921, PUB. 1-10-2012. MULTIPLE CLASS, INT. CLS. 9, 35 AND 41.
- GENERAL HYDROGEN CORPORATION, RICHMOND, BC V6V 2J2, CANADA:
2,967,575, CANC. INT. CL. 9.
- GENERAL MAGNAPLATE CORPORATION, LINDEN, NJ:
1,221,211, REN. 2-21-12. MULTIPLE CLASS, INT. CLS. 40 AND 42.
- GENERAL MILLS, INC., MINNEAPOLIS, MN:
2,968,683, CANC. INT. CL. 29.
- GENERAL MOTORS LLC, DETROIT, MI:
2,522,861, REN. 2-21-12. INT. CL. 28.
2,968,214, CANC. INT. CL. 12.
2,968,665, CANC. INT. CL. 12.
4,117,179, PUB. 1-10-2012. INT. CL. 7.
- GENERATIONS GOLD, INC., WEST PALM BEACH, FL:
2,967,362, CANC. INT. CL. 35.
- GENERICA GMBH, FRANKENWINHEIM, FED REP GERMANY:
4,116,829, PUB. 1-10-2012. MULTIPLE CLASS, INT. CLS. 6, 7 AND 35.
- GENESIS IP LLC, KENNETT SQUARE, PA:
2,967,410, CANC. MULTIPLE CLASS, INT. CLS. 35 AND 42.
- GENEST CONCRETE WORKS, INC., SANFORD, ME:
2,669,126, REN. 2-22-12. INT. CL. 19.
- GENOME COSMETICS LLC, BENSLEM, PA, DBA OBEY YOUR BODY LLC:
4,118,070, PUB. 1-10-2012. INT. CL. 3.
- GEO SPECIALTY CHEMICALS, INC., LAFAYETTE, OH:
1,184,318, REN. 2-17-12. INT. CL. 1.
1,184,405, REN. 2-22-12. INT. CL. 4.
- GEOFFREY, LLC, WAYNE, NJ:
2,548,257, REN. 2-21-12. MULTIPLE CLASS, INT. CLS. 8, 10, 21 AND 25.
2,967,459, CANC. INT. CL. 28.
- GEORG-SIMON-OHM-HOCHSCHULE FÜR ANGEWANDTE WISSENSCHAFTEN - FACHHOCHSCHULE NÜRNBERG, NÜRNBERG, FED REP GERMANY:
4,116,889, PUB. 1-10-2012. MULTIPLE CLASS, INT. CLS. 9, 11 AND 42.
- GEORGE & COMPANY, LLC, NAPLES, FL:
4,119,570, MULTIPLE CLASS, INT. CLS. 9 AND 41.
- GEORGE T, GUINANE, MANCHESTER, MA, AKA GEORGE THOMAS:
4,119,254, INT. CL. 9.
- GEORGIA-PACIFIC CONSUMER PRODUCTS LP, ATLANTA, GA:
4,118,277, PUB. 1-10-2012. INT. CL. 21.
- GEORGIA-PACIFIC LLC, ATLANTA, GA:
4,119,046, INT. CL. 35.
- GEORGIA'S OWN CREDIT UNION, ATLANTA, GA:
4,119,683, INT. CL. 36.

GEOSEMBLE TECHNOLOGIES INC., EL SEGUNDO, CA:
 4,117,252, PUB. 1-10-2012. MULTIPLE CLASS, INT. CLS. 9
 AND 42.

GEOTRICITY, LLC, MENTOR, OH:
 4,118,469, PUB. 1-10-2012. INT. CL. 7.

GEOX SPA, I-31044 BIADENE DI MONTEBELLUNA (TV),
 ITALY:
 4,116,684, PUB. 1-10-2012. INT. CL. 25.

GERHARD H. WENGLORZ, 72160 HORB, FED REP GER-
 MANY:
 4,116,807, PUB. 1-10-2012. INT. CL. 35.

GES ELECTRIC AERO CORPORATION, KELOWNA, B.C.,
 CANADA:
 4,117,043, PUB. 1-10-2012. MULTIPLE CLASS, INT. CLS.
 40 AND 42.

GES GLOBAL ENERGY SERVICES, INC., HOUSTON, TX:
 4,116,557, PUB. 1-10-2012. MULTIPLE CLASS, INT. CLS. 6
 AND 9.

GFM LICENSING GROUP LLC, WESTBROOK, CT:
 4,117,118, PUB. 1-10-2012. MULTIPLE CLASS, INT. CLS.
 25 AND 35.
 4,117,311, PUB. 1-10-2012. MULTIPLE CLASS, INT. CLS.
 25 AND 35.

GIANFAGNA, JOHN, FISHERS, IN:
 2,968,638, CANC. INT. CL. 41.

GIANT A & M, INC., SAN MARCOS, CA:
 2,967,711, CANC. INT. CL. 15.

GIELLE S.R.L., I-70051 BARLETTA (BA), ITALY:
 4,116,723, PUB. 1-10-2012. MULTIPLE CLASS, INT. CLS.
 18 AND 25.

GIFTANGO CORPORATION, PORTLAND, OR:
 4,118,223, PUB. 1-10-2012. MULTIPLE CLASS, INT. CLS.
 35 AND 42.
 4,118,235, PUB. 1-10-2012. MULTIPLE CLASS, INT. CLS.
 35 AND 42.

GIGA-BYTE TECHNOLOGY CO., LTD., TAIPEI, TAIWAN:
 4,117,738, PUB. 1-10-2012. INT. CL. 9.

GILMER, GEORGE T., CONROE, TX:
 4,117,582, PUB. 1-10-2012. INT. CL. 9.

GIMBORN PET SPECIALTIES, LLC, ATLANTA, GA:
 1,184,733, REN. 2-22-12. INT. CL. 21.
 1,184,733, CANC. MULTIPLE CLASS, INT. CLS. 16 AND
 31.

GINGER CLEAN, INC., RAPID CITY, MI:
 4,117,012, PUB. 1-10-2012. INT. CL. 3.

GINGERCUBE, INC., FLOWER MOUND, TX:
 4,119,295, MULTIPLE CLASS, INT. CLS. 9 AND 42.
 4,119,296, MULTIPLE CLASS, INT. CLS. 9 AND 42.

GINGERLILY COSMETICS LIMITED, NOTTINGHAM,
 UNITED KINGDOM:
 4,118,942, INT. CL. 3.

GINGOLD THEATRICAL GROUP, INC, NEW YORK, NY:
 4,117,960, PUB. 1-10-2012. INT. CL. 41.

GINSENG SCIENCE INC., SEOUL 151-742, REPUBLIC OF
 KOREA:
 3,043,315, CANC. MULTIPLE CLASS, INT. CLS. 29, 30
 AND 32.

GIRL MANIA, INC., LOS ANGELES, CA:
 2,967,507, CANC. MULTIPLE CLASS, INT. CLS. 20 AND
 24.

GIRL SKATEBOARD COMPANY, INC., TORRANCE, CA:
 2,525,429, REN. 2-21-12. MULTIPLE CLASS, INT. CLS. 18,
 25 AND 28.

GIUSEPPE VITALE, BROOKLYN, NY:
 3,645,485, CANC. INT. CL. 30.

GIVELOCALLY LLC, LOS ALTOS, CA:
 4,118,703, PUB. 1-10-2012. INT. CL. 36.

GIVES BACK COMPANY, LLC, FRANKLIN, TN:
 4,117,340, PUB. 1-10-2012. INT. CL. 36.

GLAS-COL, LLC, TERRE HAUTE, IN:
 1,700,329, REN. 2-23-12. INT. CL. 9.

GLAS, ROBERT, WALKER VALLEY, NY AND YOVANE,
 GREGORY, CORTLANDT MANOR, NY:
 4,119,678, INT. CL. 32.

GLAXO GROUP LIMITED, GREENFORD, MIDDLESEX,
 ENGLAND:
 2,968,225, CANC. INT. CL. 16.

GLAXOSMITHKLINE LLC, WILMINGTON, DE:
 1,739,407, REN. 2-23-12. INT. CL. 5.
 2,968,046, CANC. INT. CL. 35.
 4,119,246, INT. CL. 10.

GLIKSMAN COSMETICS LTD., NETANYA, ISRAEL:
 4,117,800, PUB. 1-10-2012. INT. CL. 3.

GLOBAL ACTION, COLORADO SPRINGS, CO:
 4,118,145, PUB. 1-10-2012. INT. CL. 45.

GLOBAL HEALTH PRODUCTS, INC., ROCHESTER, NY:
 4,119,603, INT. CL. 5.

GLOBAL HUNTER SECURITIES, LLC, NEW ORLEANS, LA:
 4,117,824, PUB. 1-10-2012. MULTIPLE CLASS, INT. CLS.
 35 AND 36.

GLOBAL MAJIC SOFTWARE, INC., HUNTSVILLE, AL:
 2,468,563, CANC. INT. CL. 9.

GLOBAL MARINE PHYTOPLANKTON COMPANY, LLC,
 RENO, NV:
 4,119,639, MULTIPLE CLASS, INT. CLS. 3 AND 5.

GLOBAL MARKETING RESOURCES, INC., DUNEDIN, FL:
 4,118,879, INT. CL. 9.

GLOBALIA EXPLOTACIONES HOTELERAS, S.L., SPAIN:
 4,116,701, PUB. 1-10-2012. INT. CL. 43.

GLOBALSPEC, INC., EAST GREENBUSH, NY, GLOBAL-
 SPEC, INC., EAST GREENBUSH, NY:
 2,523,953, REN. 2-17-12. INT. CL. 35.

GLOBEWORKS PTY LTD, AUSTRALIA:
 4,116,717, PUB. 1-10-2012. INT. CL. 16.

GLOBO COMUNICACAO E PARTICIPACOES S.A., RIO DE
 JANEIRO, RJ, BRAZIL:
 2,521,724, REN. 2-17-12. MULTIPLE CLASS, INT. CLS. 38,
 41 AND 42.

GLOBUS MEDICAL, INC., AUDUBON, PA:
 4,118,832, INT. CL. 10.

GLORY HOLDING LIMITED, KOWLOON, HONG KONG:
 4,117,299, PUB. 1-10-2012. MULTIPLE CLASS, INT. CLS.
 11 AND 19.
 4,117,300, PUB. 1-10-2012. INT. CL. 11.
 4,117,301, PUB. 1-10-2012. INT. CL. 11.
 4,117,302, PUB. 1-10-2012. INT. CL. 7.

GLYNN ELECTRIC CO., PLYMOUTH, MA:
 2,594,182, REN. 2-21-12. INT. CL. 37.

GO CANCUN, L.L.C., FT. LAUDERDALE, FL:
 2,968,001, CANC. MULTIPLE CLASS, INT. CLS. 16, 39
 AND 41.

GO PRODUCTIONS, DENVER, CO:
 4,117,346, PUB. 1-10-2012. INT. CL. 41.
 4,117,347, PUB. 1-10-2012. INT. CL. 41.

GODINGER SILVER ART CO., LTD., RIDGEWOOD, NY:
 2,538,750, REN. 2-21-12. MULTIPLE CLASS, INT. CLS. 14
 AND 20.
 2,538,750, CANC. INT. CL. 21.

GODSON, REBECCA, CARLSBAD, CA:
 4,119,627, INT. CL. 25.

GOGGIN SORAYA, UNITED KINGDOM:
 4,116,789, PUB. 1-10-2012. MULTIPLE CLASS, INT. CLS.
 3, 25 AND 35.

GOJO INDUSTRIES, INC., AKRON, OH:
 2,967,676, CANC. INT. CL. 9.

GOLDBERG, ELLIOTT, SCARSDALE, NY:
 4,118,153, PUB. 1-10-2012. INT. CL. 10.
 4,118,154, PUB. 1-10-2012. INT. CL. 10.
 4,118,306, PUB. 1-10-2012. INT. CL. 10.

GOLDEN EMPEROR INTERNATIONAL LTD., TAIPEI,
 TAIWAN:
 4,117,754, PUB. 1-10-2012. INT. CL. 9.

GOLDEN SOL MUSIC LLC, SAN FRANCISCO, CA:
 4,117,548, PUB. 1-10-2012. INT. CL. 9.

GOLDEN VALLEY BEVERAGE COMPANY, MCMINN-
 VILLE, OR:
 2,466,899, CANC. INT. CL. 32.

GOLDER PASTE TECHNOLOGY LTD., SUDBURY, ON-
 TARIO, CANADA:
 4,116,598, PUB. 1-10-2012. INT. CL. 42.

GOLDFINGER BULLION RESERVE CORPORATION, CA-
 MARILLO, CA:
 2,774,451, CANC. INT. CL. 36.

GOLDMAN, ROBERT, ROCKVILLE CENTER, NY:
 1,654,360, REN. 2-21-12. INT. CL. 24.

- GOLDMAN, ROBERT L., BEVERLY HILLS, CA:
4,117,028, PUB. 1-10-2012. INT. CL. 25.
- GOLDSCHMIDT VINEYARDS LLC, HEALDSBURG, CA, TA
FIVE GOLD HANDS:
4,116,883, PUB. 1-10-2012. INT. CL. 33.
- GONE SCRAPPIN', INC., PARK CITY, UT:
2,967,583, CANC. INT. CL. 16.
- GONZALEZ AND TAPANES FOODS, INC, MOONACHIE,
NJ:
4,081,579, COR. MULTIPLE CLASS, INT. CLS. 25, 29, 30
AND 32.
- GOOD AND FAIR CLOTHING LLC, AUSTIN, TX:
4,119,164, INT. CL. 25.
- GOOD LUCK RANCH, L.C., FAIRFIELD, IA:
2,467,235, CANC. INT. CL. 18.
- GOOD NEWS VENTURES, INC., WINCHESTER, KY:
2,467,361, CANC. INT. CL. 42.
- GOOD SPORTS, INC., MANCHESTER, CT:
4,118,663, PUB. 1-10-2012. INT. CL. 35.
- GOODRICH CORPORATION, CHARLOTTE, NC:
2,967,335, CANC. INT. CL. 1.
- GOOGLE INC., MOUNTAIN VIEW, CA:
3,140,793, AM. MULTIPLE CLASS, INT. CLS. 9, 11, 16, 18,
21, 25, 28, 35, 38 AND 42.
- GORDON FERON & CO., INC., QUAIL VALLEY, CA:
2,467,677, CANC. INT. CL. 3.
- GORDON RESTAURANT GROUP, LLC, LOS ANGELES,
CA:
4,118,045, PUB. 1-10-2012. INT. CL. 43.
- GORMAN, ANDREW J., CINCINNATI, OH, DBA FREE
FLOW CREATIONS:
4,117,373, PUB. 1-10-2012. INT. CL. 40.
- GOTTLIEB, CHARLES L., WATERFORD, MI:
2,910,004, CANC. INT. CL. 36.
- GOZIP LLC, LAHAINA, HI:
4,117,871, PUB. 1-10-2012. INT. CL. 41.
- GQUEUES LLC, NORFOLK, VA:
4,116,947, PUB. 1-10-2012. INT. CL. 42.
- GRABOW, JIM, NEWPORT BEACH, CA:
4,117,419, PUB. 1-10-2012. INT. CL. 36.
- GRACIELA DIAZ SERRANO, MEXICO, D.F., MEXICO:
4,117,392, PUB. 1-10-2012. INT. CL. 35.
- GRACO MINNESOTA INC., MINNEAPOLIS, MN:
4,116,875, PUB. 1-10-2012. INT. CL. 7.
- GRAHAM, KEVIN, BRENTWOOD, CA:
4,118,110, PUB. 1-10-2012. INT. CL. 42.
- GRAIN PROCESSING CORPORATION, MUSCATINE, IA:
1,705,927. REN. 2-17-12. INT. CL. 30.
- GRAITEC SA, BIÈVRES, 91572, FRANCE:
4,117,175, PUB. 1-10-2012. MULTIPLE CLASS, INT. CLS. 9
AND 42.
- GRAMERCY FUNDS MANAGEMENT LLC, GREENWICH,
CT:
4,117,780, PUB. 1-10-2012. INT. CL. 36.
- GRAND CENTRAL PARTNERSHIP, INC., NEW YORK, NY:
1,729,866. REN. 2-22-12. MULTIPLE CLASS, INT. CLS. 37
AND 42.
- GRAND CREW, LLC, CHARLESTON, SC, DBA THE GIN
JOINT:
4,118,328, PUB. 1-10-2012. INT. CL. 43.
- GRAND HOSPITALITY LLC, GRAND RAPIDS, MN:
4,117,953, PUB. 1-10-2012. INT. CL. 43.
- GRANDE VITAE GMBH, FED REP GERMANY:
4,116,677, PUB. 1-10-2012. INT. CL. 33.
- GRANDWAY ASSET MANAGEMENT, INC., PASADENA,
CA:
2,527,520. REN. 2-22-12. INT. CL. 36.
- GRANNAN, ELIZABETH, ALPHARETTA, GA:
4,118,100, PUB. 1-10-2012. INT. CL. 45.
- GRANT, BOB, ACWORTH, GA:
4,119,655, INT. CL. 41.
- GRANT, STEVEN M., GOODYEAR, AZ, DBA TENKARA
PRO:
4,119,549, INT. CL. 25.
- GRANT, WINSTON J., MIAMI GARDENS, FL:
4,119,680, MULTIPLE CLASS, INT. CLS. 30 AND 43.
- GRAPE TECHNOLOGY GROUP, INC, BETHLEHEM, PA:
2,967,631, CANC. INT. CL. 35.
- GRAPHITE INTERNATIONAL B.V., NETHERLANDS:
4,116,739, PUB. 1-10-2012. MULTIPLE CLASS, INT. CLS. 1
AND 9.
- GRAVES SPRAY SUPPLY, INC., CLEARWATER, FL:
2,468,249, CANC. INT. CL. 7.
- GRAY, MICHAEL, BETHESDA, MD:
2,968,487, CANC. INT. CL. 45.
- GREAT PLACE TO WORK INSTITUTE INC., SAN FRAN-
CISCO, CA:
2,536,708. REN. 2-17-12. INT. CL. 35.
- GREAT PYRAMID, L.L.C., HUNTINGTON, NY:
2,468,135, CANC. INT. CL. 41.
- GREATER PARK CITY COMPANY, PARK CITY, UT:
4,118,705, PUB. 1-10-2012. INT. CL. 41.
- GREEN ACRES INTERNATIONAL LLC, MERCER ISLAND,
WA:
4,119,501, INT. CL. 1.
- GREEN, PAUL M., ST. AUGUSTINE, FL:
4,119,693, INT. CL. 15.
- GREENBALL CORPORATION, ANAHEIM, CA:
4,118,452, PUB. 1-10-2012. INT. CL. 35.
4,118,468, PUB. 1-10-2012. INT. CL. 35.
- GREENBRIDGE COMPUTING, INC., BELLEVUE, WA:
4,118,169, PUB. 1-10-2012. INT. CL. 42.
- GREENKARMA, LLC, CHICAGO, IL:
4,117,505, PUB. 1-10-2012. INT. CL. 3.
- GREENO, LAURA, HUNTERSVILLE, NC:
4,117,537, PUB. 1-10-2012. INT. CL. 35.
- GREENPROFIT SOLUTIONS, INC., PLANTATION, FL:
4,117,177, PUB. 1-10-2012. INT. CL. 35.
- GREENSHOPS.COM INC, BAKERSFIELD, CA:
4,117,848, PUB. 1-10-2012. INT. CL. 35.
- GREENTECH ENVIRONMENTAL, GRAY, TN:
4,046,426, COR. INT. CL. 11.
- GREER LABORATORIES, INC., LENOIR, NC:
4,119,029, INT. CL. 44.
- GREER, WILLIAM A, RUCKERSVILLE, VA AND GREER,
DEDREA A, RUCKERSVILLE, VA:
4,119,845, INT. CL. 8.
- GRENADÉ, INC., PORTLAND, OR:
2,967,841, CANC. INT. CL. 25.
- GRIFFITH ENERGY SERVICES, INC., COLUMBIA, MD:
4,117,629, PUB. 1-10-2012. INT. CL. 37.
- GRINE, CHRISTOPHER A, LEE'S SUMMIT, MO:
4,117,151, PUB. 1-10-2012. INT. CL. 16.
- GROHE AG, FED REP GERMANY:
4,116,786, PUB. 1-10-2012. INT. CL. 11.
- GROSS, BEN, LAKEWOOD, NJ:
4,118,247, PUB. 1-10-2012. INT. CL. 34.
- GROTE INDUSTRIES, INC., MADISON, IN, GROTE MAN-
UFACTURING COMPANY, THE, MADISON, IN:
734,084. REN. 2-21-12. U.S. CL. 21 (INT. CL. 11).
- GROTHUSEN, DUSTY JOHNSON, SCOTT, KS:
2,968,649, CANC. INT. CL. 28.
- GROUP CARES, LOVELAND, CO:
4,118,755, INT. CL. 35.
- GROUP KAITU, LLC, RICHMOND, VA:
4,116,554, PUB. 1-10-2012. INT. CL. 35.
- GROUT DOCTOR GLOBAL FRANCHISE CORP., SALT
LAKE CITY, UT:
2,525,210. REN. 2-22-12. INT. CL. 37.
- GROWING ROSE'S FOUNDATION, COLUMBUS, OH:
4,118,156, PUB. 1-10-2012. INT. CL. 36.
- GROWLITE, INC., WHITTIER, CA:
4,118,653, PUB. 1-10-2012. INT. CL. 11.
- GROWTHLEADERS, INC., BETHLEHEM, PA:
4,116,647, PUB. 1-10-2012. MULTIPLE CLASS, INT. CLS.
35 AND 41.
- GRUBB, BETH NALLEY, SEA ISLAND, GA, DBA EMMA
GARNETT JEWELRY:
4,117,750, PUB. 1-10-2012. INT. CL. 14.
- GRUBER, JACOB A., ROSELLE, IL:
2,968,050, CANC. INT. CL. 9.
- GRUPO AEROMEXICO, S.A. DE C.V., DISTRITO FEDERAL,
MEXICO:
4,117,440, PUB. 1-10-2012. INT. CL. 39.

GRUPO AVAL ACCIONES Y VALORES S.A., SANTAFE DE BOGOTA, COLOMBIA:
4,118,915, MULTIPLE CLASS, INT. CLS. 35 AND 36.

GRUPO BIMBO S.A.B. DE C.V., MEXICO, DISTRITO FEDERAL, MEXICO:
4,116,995, PUB. 1-10-2012. INT. CL. 30.

GRUPO OMNILIFE, S.A. DE C.V., GUADALAJARA, JALISCO, MEXICO, DBA GOM 940311 LF7:
4,119,466, INT. CL. 5.

GRUPPO DECORTEX S.R.L., ITALY:
4,116,731, PUB. 1-10-2012. MULTIPLE CLASS, INT. CLS. 25 AND 28.
4,116,732, PUB. 1-10-2012. MULTIPLE CLASS, INT. CLS. 25 AND 28.

GRYSON N.V., BELGIUM:
2,967,225.

GST INTERNATIONAL, LLC, SANTA ROSA, CA:
4,118,920, INT. CL. 19.

GUARDIAN BUILDING PRODUCTS DISTRIBUTION, INC., GREENVILLE, SC:
4,119,464, INT. CL. 17.

GUASCH CACERES, LUIS ALBERTO, SAN SALVADOR, EL SALVADOR:
4,117,239, PUB. 1-10-2012. INT. CL. 43.

GUDZAN, RICHARD, BIRMINGHAM, AL:
4,119,445, INT. CL. 25.

GUENOC WINERY, INC., MIDDLETOWN, CA:
2,633,229, REN. 2-21-12. INT. CL. 33.

GUESTSHOTS, INC., HILLIARD, OH:
4,117,912, PUB. 1-10-2012. INT. CL. 42.

GUIDE-POD, INC., SAN JUAN, PUERTO RICO:
4,117,782, PUB. 1-10-2012. MULTIPLE CLASS, INT. CLS. 35 AND 39.

GULFSTREAM AEROSPACE CORPORATION, SAVANNAH, GA:
2,522,633, REN. 2-22-12. INT. CL. 37.

GUTIEREZ, MARCO ENRIQUE LEON, LOS ANGELES, CA:
4,119,533, INT. CL. 25.

GUTIERREZ, JORGE E, CLIFTON, NJ:
2,968,062, CANC. INT. CL. 25.

GUTMANN AG, 91781 WEIBENBURG, FED REP GERMANY:
4,116,811, PUB. 1-10-2012. MULTIPLE CLASS, INT. CLS. 6, 17 AND 19.

GUTSY WOMEN TRAVEL, LLC, VALLEY STREAM, NY:
2,671,709, REN. 2-22-12. MULTIPLE CLASS, INT. CLS. 39 AND 43.

GUTFREUND, SASCHA, AUSTIN, TX:
4,117,884, PUB. 1-10-2012. MULTIPLE CLASS, INT. CLS. 35 AND 41.

GWATHMEY, INC., CAMBRIDGE, MA:
2,468,499, CANC. INT. CL. 42.

G22-ALTESSE CO., LTD., NEW YORK, NY:
2,467,178, CANC. INT. CL. 25.

H. E. ANDERSON COMPANY, MUSKOGEE, OK:
1,205,201, REN. 2-17-12. INT. CL. 9.

H. KRIEGHOFF GMBH, FED REP GERMANY:
4,116,823, PUB. 1-10-2012. INT. CL. 13.

H.D. VEST, INC., MINNEAPOLIS, MN:
2,561,056, REN. 2-19-12. MULTIPLE CLASS, INT. CLS. 35, 36 AND 42.

H.J. BAKER & BRO., INC., WESTPORT, CT:
4,119,365, INT. CL. 5.

H.S. CROCKER CO., INC., HUNTLEY, IL:
2,639,155, REN. 2-23-12. INT. CL. 42.

H&S PERFORMANCE, ST. GEORGE, UT:
4,117,928, PUB. 1-10-2012. INT. CL. 35.

H-D MICHIGAN, LLC, ANN ARBOR, MI:
1,708,418, REN. 2-23-12. INT. CL. 28.
2,602,506, REN. 2-21-12. INT. CL. 12.

HAASNOOT, RICHARD D., GLENDALE, AZ:
2,468,536, CANC. INT. CL. 41.

HABO CABO, INC., RANCHO CORDOVA, CA:
4,118,389, PUB. 1-10-2012. INT. CL. 30.

HAFABROWNDDESIGNS, VACAVILLE, CA:
4,119,675, INT. CL. 25.
4,119,676, INT. CL. 25.
4,119,713, INT. CL. 25.
4,119,714, INT. CL. 25.

HAGGERTY, JAMES P., FLORAL PARK, NY:
4,117,173, PUB. 1-10-2012. INT. CL. 9.

HAGGERTY, TERESA ANNE, PENSACOLA BEACH, FL:
4,119,511, INT. CL. 16.

HAIDER, DEEBA, SANTA MONICA, CA:
4,117,903, PUB. 1-10-2012. MULTIPLE CLASS, INT. CLS. 35 AND 41.

HAINSWORTH, CRAIG, CORONA, CA:
4,119,665, INT. CL. 37.

HAIR-SEGURA, LYNN, LAFAYETTE, LA:
2,967,662, CANC. INT. CL. 41.

HALLIBURTON ENERGY SERVICES, INC., CARROLLTON, TX, N L INDUSTRIES, INC., NEW YORK, NY:
1,185,291, REN. 2-21-12. INT. CL. 1.

HAMBOLU, LLC, INDEPENDENCE, MO:
2,525,480, REN. 2-21-12. INT. CL. 41.

HAMPTON PRODUCTS INTERNATIONAL CORPORATION, FOOTHILL RANCH, CA:
2,545,181, REN. 2-23-12. INT. CL. 17.

HANDSOME CYCLES, LLC, MINNEAPOLIS, MN:
4,118,701, PUB. 1-10-2012. INT. CL. 12.

HANDYSOFT GLOBAL CORPORATION, VIENNA, VA:
2,968,448, CANC. MULTIPLE CLASS, INT. CLS. 9, 41 AND 42.

HANEBERG, ANTHONY OWEN, SALISAW, OK:
4,117,228, PUB. 1-10-2012. INT. CL. 13.

HANLEY-WOOD, LLC, WASHINGTON, DC:
2,468,599, CANC. INT. CL. 35.
4,118,401, PUB. 1-10-2012. INT. CL. 35.

HANS TURCK GMBH & CO. K.G., 45472 MUELHEIM/RUHR, FED REP GERMANY:
2,550,290, REN. 2-22-12. INT. CL. 9.
2,550,290, COR. INT. CL. 9.

HANSABIOMED OU, TALLINN, ESTONIA:
4,117,980, PUB. 1-10-2012. INT. CL. 5.

HARBOUR, TREVOR H, PHOENIX, AZ:
4,117,525, PUB. 1-10-2012. INT. CL. 41.

HARD WEAR CLOTHING, OCEANSIDE, CA:
2,464,765, REN. 2-17-12. INT. CL. 25.

HARLEQUIN CHEMICALS LTD., RADCLIFFE, GREATER MANCHESTER, UNITED KINGDOM:
2,967,420, CANC. MULTIPLE CLASS, INT. CLS. 1 AND 3.

HARMONY LABS, INC., KANNAPOLIS, NC:
2,468,232, CANC. INT. CL. 3.

HARRIS LIQUORS, INC., COAL VALLEY, IL, DBA HARRIS PIZZA:
4,118,516, PUB. 1-10-2012. INT. CL. 30.

HARRIS NESBITT GERARD, INC., NEW YORK, NY:
2,967,942, CANC. INT. CL. 36.

HARRIS PUBLICATIONS, INC., NEW YORK, NY:
2,642,503, REN. 2-17-12. INT. CL. 16.

HARRIS TEETER, INC., MATTHEWS, NC:
2,968,590, CANC. MULTIPLE CLASS, INT. CLS. 29, 31 AND 32.

HARRIS, STEPHEN, MONROE, OK AND REED, JOHN E. III, MONROE, OK AND WISE, DONNIE, MONROE, OK:
4,117,890, PUB. 1-10-2012. INT. CL. 41.

HARRIS, TARA A., DUBLIN, OH:
2,968,428, CANC. INT. CL. 21.

HARSTER, MARCO A., FLUSHING, NY:
2,967,842, CANC. INT. CL. 20.

HARTE-HANKS SHOPPERS, INC., BREA, CA, DBA PENNY-SAVERUSA.COM:
4,119,667, MULTIPLE CLASS, INT. CLS. 9 AND 42.

HARVARD BUILDING SERVICES, INC., NEW YORK, NY:
4,119,474, INT. CL. 37.

HASA, INCORPORATED, SAUGUS, CA:
2,535,239, REN. 2-22-12. INT. CL. 1.

HASBRO, INC., PAWTUCKET, RI:
4,117,291, PUB. 1-10-2012. INT. CL. 28.

HASPEL, L.L.C., BATON ROUGE, LA, HASPEL BROTHERS, INC., NEW ORLEANS, LA:
727,756, REN. 2-22-12. U.S. CL. 39 (INT. CL. 25).

- HASSAN, AYHAN, PORT WASHINGTON, NY:
2,968,592, CANC. INT. CL. 44.
2,968,811, CANC. MULTIPLE CLASS, INT. CLS. 29 AND 30.
- HATTERAS HAMMOCKS, INC., GREENVILLE, NC:
2,967,938, CANC. INT. CL. 22.
2,967,939, CANC. INT. CL. 22.
- HAUL-ALL EQUIPMENT LTD., LETHBRIDGE, ALBERTA, CANADA:
2,529,252, REN. 2-23-12. INT. CL. 11.
- HAULSEE, JUANITA, RANDALLSTOWN, MD:
4,118,132, PUB. 1-10-2012. MULTIPLE CLASS, INT. CLS. 9, 16 AND 41.
- HAYASHI, YOSHIKI, LOS ANGELES, CA, HAYASHI, YOSHIKI, LOS ANGELES, CA:
2,507,413, REN. 2-22-12. INT. CL. 9.
- HAYWARD INDUSTRIES, INC., ELIZABETH, NJ:
4,117,446, PUB. 1-10-2012. INT. CL. 20.
4,118,702, PUB. 1-10-2012. MULTIPLE CLASS, INT. CLS. 7, 9 AND 11.
- HCPLEXUS, INC., DARIEN, CT:
4,118,133, PUB. 1-10-2012. MULTIPLE CLASS, INT. CLS. 9, 16 AND 35.
4,118,134, PUB. 1-10-2012. MULTIPLE CLASS, INT. CLS. 9, 16 AND 35.
- HDMI LICENSING, L.L.C., SUNNYVALE, CA:
4,117,692, PUB. 1-10-2012. INT. CL. 9.
- HEALTH INTERNATIONAL CORPORATION, ST. PETERSBURG, FL:
2,967,435, CANC. INT. CL. 5.
- HEALTH PLUS INC., CHINO, CA:
2,560,598, REN. 2-19-12. INT. CL. 5.
- HEALTH RESEACH, INCORPORATED, MENANDS, NY:
4,117,030, PUB. 1-10-2012. MULTIPLE CLASS, INT. CLS. 35 AND 36.
- HEALTH RESEARCH, INC., MENANDS, NY:
4,118,402, PUB. 1-10-2012. INT. CL. 42.
- HEALTH-E ENTERPRISES, LLC, DELRAY BEACH, FL:
4,117,335, PUB. 1-10-2012. INT. CL. 41.
- HEALTHBANKS, INC., BURLINGTON, MA:
2,967,675, CANC. MULTIPLE CLASS, INT. CLS. 38, 41 AND 44.
- HEALTH2O PRODUCTS, LLC, DALLAS, TX:
4,118,944, INT. CL. 32.
- HEART OF AMERICA E-COMMERCE, L.L.C., LAWRENCE, KS:
4,117,650, PUB. 1-10-2012. INT. CL. 35.
- HEARTHWARE, INC., LIBERTYVILLE, IL:
4,119,622, INT. CL. 2.
- HEARTSHINES, INC., EVANSVILLE, IN, DBA CHUNJIDO ASSOCIATION:
4,118,535, PUB. 1-10-2012. INT. CL. 41.
- HEAT CONTROLLER, INC., JACKSON, MI:
1,682,816, REN. 2-22-12. INT. CL. 11.
- HEBEI YIKANG KNITTING AND COTTON, LTD., SHIJIAZHANG, CHINA:
4,119,138, INT. CL. 24.
- HEELLO, INC., CHARLESTON, SC:
4,118,611, PUB. 1-10-2012. INT. CL. 41.
4,118,646, PUB. 1-10-2012. INT. CL. 38.
- HELIX COMPUTER SYSTEMS, INC., CHARLOTTESVILLE, VA, DBA HELIX COMPUTER SYSTEMS:
4,118,183, PUB. 1-10-2012. MULTIPLE CLASS, INT. CLS. 38 AND 42.
- HELLO CRAFT, WASHINGTON, DC:
4,117,433, PUB. 1-10-2012. INT. CL. 41.
- HELM AGRO US, INC., MEMPHIS, TN:
4,118,714, PUB. 1-10-2012. INT. CL. 5.
- HELP AT HOME, INC., CHICAGO, IL:
4,119,741, MULTIPLE CLASS, INT. CLS. 37, 39 AND 44.
- HELPLINK CORPORATION, SHERMAN OAKS, CA:
4,117,387, PUB. 1-10-2012. INT. CL. 35.
- HENDRICKS HOLDING COMPANY, INC., BELOIT, WI:
2,468,206, CANC. INT. CL. 11.
- HENERGY GROUP (NORTH AMERICA) INC., VANCOUVER BC V7X 1L3, CANADA:
4,119,605, INT. CL. 11.
- HENKEL CORPORATION, ROCKY HILL, CT:
294,808, REN. 2-22-12. U.S. CL. 6 (INT. CL. 1).
4,118,315, PUB. 1-10-2012. INT. CL. 17.
- HENRY, ROBERT L., CARSON CITY, NV:
2,968,251, CANC. INT. CL. 12.
- HERALD INTERACTIVE INC., BOSTON, MA:
2,593,360, REN. 2-17-12. INT. CL. 35.
- HERBALIFE INTERNATIONAL, INC., LOS ANGELES, CA:
2,968,498, CANC. INT. CL. 5.
- HERBRUCK POULTRY RANCH, INC., SARANAC, MI:
4,119,055, INT. CL. 39.
- HERBS, ETC., INC., SANTA FE, NM:
2,666,696, REN. 2-21-12. INT. CL. 5.
2,672,379, REN. 2-23-12. INT. CL. 5.
- HERCULES INCORPORATED, WILMINGTON, DE, HERCULES POWDER COMPANY, WILMINGTON, DE:
559,945, REN. 2-22-12. U.S. CL. 6 (INT. CL. 1).
- HERITAGE RESTAURANTS LLC, SANTA CLARITA, CA:
4,118,231, PUB. 1-10-2012. INT. CL. 43.
- HERMAN MILLER, INC., ZEELAND, MI:
2,468,411, CANC. INT. CL. 35.
- HERMAN, ROBERT S., WILLISTON, ND, DBA ENVIRO SHIELD PRODUCTS:
2,563,234, REN. 2-17-12. INT. CL. 17.
- HERNON MANUFACTURING, INC., SANFORD, FL:
4,117,001, PUB. 1-10-2012. INT. CL. 17.
- HEWLETT-PACKARD DEVELOPMENT COMPANY, L.P., HOUSTON, TX, HEWLETT-PACKARD COMPANY, PALO ALTO, CO:
2,530,140, REN. 2-23-12. INT. CL. 42.
- HEWY WINE CHILLERS, LLC, ORLANDO, FL:
4,119,704, INT. CL. 21.
- HEYROOMEE LLC, WHITE PLAINS, NY:
4,119,215, INT. CL. 45.
- HI-HEALTH SUPERMART CORPORATION, SCOTTSDALE, AZ:
1,197,635, REN. 2-21-12. INT. CL. 5.
1,212,787, REN. 2-22-12. INT. CL. 42.
- HI-REZ STUDIOS, INC., ALPHARETTA, GA:
4,119,537, INT. CL. 38.
4,119,538, INT. CL. 41.
4,119,580, INT. CL. 38.
4,119,581, INT. CL. 41.
- HI-TEK RATIONS, INC., DUBLIN, GA:
4,117,998, PUB. 1-10-2012. INT. CL. 31.
4,118,305, PUB. 1-10-2012. INT. CL. 31.
- HIDE-AWAY IRONING BOARDS, INC., BROKEN ARROW, OK:
2,467,691, CANC. INT. CL. 21.
- HIGGINS AND LOVETT, PLEASANT HILL, CA:
4,117,594, PUB. 1-10-2012. INT. CL. 35.
- HIGGINS CAPITAL MANAGEMENT, INC., LA JOLLA, CA:
4,118,155, PUB. 1-10-2012. INT. CL. 36.
- HIGH COUNTRY INVESTOR, INC., SAUGUS, MA:
4,117,683, PUB. 1-10-2012. INT. CL. 35.
- HIGHLAND PLATING CO., INC., LOS ANGELES, CA:
2,467,023, CANC. INT. CL. 40.
- HIGHLAND TANK AND MANUFACTURING COMPANY, STOYSTOWN, PA:
1,732,458, REN. 2-21-12. INT. CL. 6.
- HILL-ROM SERVICES, INC., BATESVILLE, IN:
2,606,905, REN. 2-23-12. INT. CL. 10.
- HILL'S PET NUTRITION, INC., TOPEKA, KS:
2,968,475, CANC. INT. CL. 31.
- HILLARY TAYLOR, INC., NEW YORK, NY:
2,968,636, CANC. INT. CL. 35.
- HILLEY, CONNIE J., ROSSVILLE, GA:
4,119,115, INT. CL. 25.
- HILLS-MCCANNA, LLC, KENTWOOD, MI:
4,117,230, PUB. 1-10-2012. INT. CL. 6.
- HIMALAYAN INTERNATIONAL INSTITUTE OF YOGA SCIENCE AND PHILOSOPHY OF THE USA, HONESDALE, PA:
2,460,882, REN. 2-17-12. INT. CL. 41.
- HISLE, MARK E., EVANSVILLE, IN:
4,118,291, PUB. 1-10-2012. INT. CL. 13.
- HITACHI MEDICAL CORPORATION, TOKYO, JAPAN:
4,117,633, PUB. 1-10-2012. INT. CL. 10.

HITOP (XIAMEN) MECHANICAL INDUSTRY CO., LTD., CHINA:
4,116,865, PUB. 1-10-2012. MULTIPLE CLASS, INT. CLS. 7 AND 12.

HMC INTERNATIONAL, LLC, ROME, NY:
2,466,862, CANC. INT. CL. 20.

HO, WAI YAN, MORGAN HILL, CA:
4,116,661, PUB. 1-10-2012. INT. CL. 9.
4,116,662, PUB. 1-10-2012. INT. CL. 9.

HODDER, ELLIE J., PORTLAND, OR:
2,525,313, REN. 2-22-12. INT. CL. 41.

HOECHST GMBH, 65926 FRANKFURT AM MAIN, FED REP GERMANY:
1,669,063, REN. 2-21-12. INT. CL. 2.

HOFFMASTER GROUP, INC., OSHKOSH, WI:
2,967,394, CANC. INT. CL. 16.

HOLLENBECK, GREGORY L., MAYWOOD, NJ:
4,119,738, INT. CL. 25.

HOLLEY PERFORMANCE PRODUCTS, INC., BOWLING GREEN, KY:
1,727,069, REN. 2-23-12. INT. CL. 7.

HOLOCAUST MUSEUM HOUSTON, HOUSTON, TX:
2,466,330, REN. 2-22-12. INT. CL. 41.

HOLY SPIRIT ASSOCIATION FOR THE UNIFICATION OF WORLD CHRISTIANITY, NEW YORK, NY:
4,117,285, PUB. 1-10-2012. MULTIPLE CLASS, INT. CLS. 41 AND 45.

HOME ANALYZERS DEVELOPMENT COMPANY LLC, GERMANTOWN, TN:
4,117,972, PUB. 1-10-2012. INT. CL. 35.

HOME DIAGNOSTICS, INC., FORT LAUDERDALE, FL:
2,968,164, CANC. MULTIPLE CLASS, INT. CLS. 5 AND 10.

HOME EVENTS PTY LIMITED, AUSTRALIA:
4,116,707, PUB. 1-10-2012. MULTIPLE CLASS, INT. CLS. 8, 16, 18, 20 AND 25.

HOME PNA INC., SAN RAMON, CA:
2,967,320, CANC. INT. CL. 42.

HOME SHIELD, LLC, CROMWELL, CT:
4,119,232, INT. CL. 2.

HOMER TLC, INC., CLAYMONT, DE:
2,968,462, CANC. INT. CL. 21.

HOMESTEAD PUBLISHING CO, BEL AIR, MD:
2,466,856, CANC. INT. CL. 16.

HONDA MOTOR CO., LTD., MINATO-KU, TOKYO, JAPAN:
4,119,162, INT. CL. 7.

HOOD, CASEY, ATLANTA, GA:
4,118,590, PUB. 1-10-2012. INT. CL. 41.

HOORAY, LLC, LOS ANGELES, CA:
4,117,215, PUB. 1-10-2012. INT. CL. 9.

HOPE COMMUNITY UNITED CHURCH OF CHRIST, NAPERVILLE, IL:
2,822,903, CANC. INT. CL. 45.

HOPE WINE LLC, NEWPORT BEACH, CA, DBA ONE HOPE WINE:
4,118,147, PUB. 1-10-2012. INT. CL. 41.

HOPPER, GREGORY S., RALEIGH, NC:
2,968,036, CANC. INT. CL. 9.

HOPS & PIE, DENVER, CO:
4,118,080, PUB. 1-10-2012. INT. CL. 43.

HORMEL FOODS, LLC, AUSTIN, MN:
4,118,549, PUB. 1-10-2012. MULTIPLE CLASS, INT. CLS. 29 AND 30.

HOROWITZ, LEONARD G., PAHOA, HI:
4,119,258, INT. CL. 41.

HORSCH MASCHINEN GMBH, SCHWANDORF, FED REP GERMANY:
4,119,819, INT. CL. 7.

HOSCHLER, STEPHEN, ROCKLIN, CA:
4,117,249, PUB. 1-10-2012. INT. CL. 38.

HOSHINO GAKKI CO. LTD., NAGOYA 461-8717, JAPAN:
2,549,639, REN. 2-22-12. INT. CL. 9.

HOSPI-HELP, INC., TROY, MI:
4,117,951, PUB. 1-10-2012. MULTIPLE CLASS, INT. CLS. 35 AND 36.

HOSTESS BRANDS, INC., IRVING, TX, BORDEN, INC., NEW YORK, NY:
927,855, REN. 2-21-12. U.S. CL. 46 (INT. CL. 30).

HOT BOX GRILL, LLC, SONOMA, CA:
4,117,310, PUB. 1-10-2012. INT. CL. 43.

HOT SHOPPES, INC., WASHINGTON, DC TO MARRIOTT INTERNATIONAL, INC., BETHESDA, MD:
537,680, CANC. U.S. CL. 46.

HOT SPOTS EARTH INCORPORATED, BEAVERTON, OR:
4,118,967, INT. CL. 35.

HOTFIT LLC, NEW YORK, NY, DBA SKINNYJEANS:
4,119,797, INT. CL. 25.

HOUSEDIET, S.L., BARCELONA, SPAIN:
2,968,130, CANC. INT. CL. 5.

HOUSING LEADERS LLC, SAN FRANCISCO, CA, FORMERLY HOUSINGLEADERS LLC:
4,117,314, PUB. 1-10-2012. INT. CL. 41.

HOUSLEY, ZAIDA, COCONUT GROVE, FL:
2,968,028, CANC. INT. CL. 29.

HOUSTON FIREFIGHTERS' RELIEF AND RETIREMENT FUND, HOUSTON, TX:
2,525,765, REN. 2-22-12. INT. CL. 36.

HOUSTON SERVICE INDUSTRIES, INC., HOUSTON, TX:
4,119,832, INT. CL. 7.

HOWMEDICA OSTEONICS CORP., MAHWAL, NJ:
1,183,619, REN. 2-21-12. INT. CL. 10.

HRB INNOVATIONS, INC., LAS VEGAS, NV:
4,119,392, INT. CL. 35.

HRHH IP, LLC, NEW YORK, NY:
4,118,728, PUB. 1-10-2012. INT. CL. 43.

HRM PROVISION COMPANY INC., BOYNTON BEACH, FL:
2,968,506, CANC. INT. CL. 29.

HS TM, LLC, NEWARK, DE:
4,118,676, PUB. 1-10-2012. MULTIPLE CLASS, INT. CLS. 35 AND 44.

HSN LP, ST. PETERSBURG, FL:
2,967,785, CANC. INT. CL. 35.
2,967,786, CANC. INT. CL. 35.

HSNI, LLC, DOVER, DE:
2,967,584, CANC. INT. CL. 27.

HT ITALIA S.R.L., ITALY:
4,116,780, PUB. 1-10-2012. INT. CL. 9.

HTC CORPORATION, TAOYUAN CITY, TAIWAN:
4,118,933, INT. CL. 9.
4,119,546, INT. CL. 9.
4,119,572, INT. CL. 9.

HUA NAN FINANCIAL HOLDINGS CO., LTD., TAIPEI 100, TAIWAN:
4,116,992, PUB. 1-10-2012. INT. CL. 36.
4,116,993, PUB. 1-10-2012. INT. CL. 36.

HUANG, PATRICK, BURNABY, BRITISH COLUMBIA:
555,028, REN. 2-17-12. U.S. CL. 39 (INT. CL. 25).

HUBBELL INCORPORATED, SHELTON, CT, MARLEY-WYLAIN COMPANY, THE, DALLAS, TX:
1,177,075, REN. 2-22-12. INT. CL. 11.

HUBBELL INCORPORATED, ORANGE, CT:
2,468,204, CANC. INT. CL. 9.

HUBCO AUTOMOTIVE LTD, AUCKLAND, NEW ZEALAND:
3,924,472, COR. INT. CL. 12.

HUESKER SYNTHETIC GMBH, FED REP GERMANY:
4,116,874, PUB. 1-10-2012. INT. CL. 19.

HUFFY CORPORATION, CENTERVILLE, OH:
4,118,695, PUB. 1-10-2012. INT. CL. 12.

HUGHES MARKETING, LLC, PHOENIX, AZ:
4,117,638, PUB. 1-10-2012. INT. CL. 28.

HUHTAMAKI COMPANY MANUFACTURING, DESOTO, KS:
2,467,704, CANC. INT. CL. 21.

HUMAN LOVES HUMAN, INC., NEW YORK, NY:
4,118,031, PUB. 12-13-2011. INT. CL. 41.

HUMANZYME INC., CHICAGO, IL:
4,118,525, PUB. 1-10-2012. INT. CL. 1.
4,118,527, PUB. 1-10-2012. INT. CL. 1.

HUNGRY FISH MEDIA LLC, CAMBRIDGE, MA:
4,119,724, INT. CL. 5.

HUNOLT, JUSTIN ANTHONY, MIRAMAR BEACH, FL, AKA COUNTERGROOVE:
4,119,014, INT. CL. 9.

HUNTER, JAN D., SANTA ROSA, CA:
4,117,680, PUB. 1-10-2012. INT. CL. 41.

- HUNTER'S SPECIALTIES, INC., CEDAR RAPIDS, IA:
2,968,585, CANC. INT. CL. 28.
- HURWITZ & FINE, P.C., BUFFALO, NY:
4,117,575, PUB. 10-4-2011. INT. CL. 41.
- HUTCHINSON S.A., PARIS, FRANCE:
2,967,995, CANC. INT. CL. 21.
- HYDAC FILTERTECHNIK GMBH, 66280 SULZBACH/
SAAR, FED REP GERMANY:
2,522,957. REN. 2-22-12. MULTIPLE CLASS, INT. CLS. 7,
11 AND 20.
- HYDRO ALUMINIUM DEUTSCHLAND GMBH, FED REP
GERMANY:
4,116,728, PUB. 1-10-2012. INT. CL. 6.
- HYPER NETWORK SOLUTIONS, LLC, WEST PALM
BEACH, FL:
4,119,785, INT. CL. 5.
4,119,792, INT. CL. 5.
4,119,793, INT. CL. 5.
- H2 CONSULTING, INC., MERRICK, NY:
4,117,701, PUB. 1-10-2012. INT. CL. 35.
- I AM ENTERTAINMENT, LLC, KENNESAW, GA:
4,117,353, PUB. 1-10-2012. INT. CL. 41.
- I AM PRODUCTS, LLC, WASHINGTON CROSSING, PA:
4,119,152, INT. CL. 5.
- I.T. WORX, INC., GREENSBORO, NC:
3,039,970, CANC. INT. CL. 42.
- I-TECH AB, SWEDEN:
4,116,788, PUB. 1-10-2012. MULTIPLE CLASS, INT. CLS. 2
AND 5.
- IBEDA SICHERHEITSGERATE UND GASTECHNIK GMBH
& CO. KG, 53577 NEUSTADT/WIED, FED REP GER-
MANY:
1,670,964. REN. 2-22-12. MULTIPLE CLASS, INT. CLS. 7
AND 8.
- IB5K, LLC, SAN FRANCISCO, CA:
4,116,949, PUB. 1-10-2012. MULTIPLE CLASS, INT. CLS.
35 AND 41.
- ICE MATTERS, LLC, CHESHIRE, CT:
4,117,218, PUB. 1-10-2012. MULTIPLE CLASS, INT. CLS.
19 AND 41.
- ICEE COMPANY, ONTARIO, CA, SLUSH PUPPIE COR-
PORATION, CINCINNATI, OH:
1,669,662. REN. 2-21-12. INT. CL. 32.
1,669,663. REN. 2-21-12. INT. CL. 32.
- ICHAR, SILVIA B., SAN JUAN CAPISTRANO, CA:
2,968,018, CANC. INT. CL. 16.
- IDAHO-EASTERN OREGON ONION COMMITTEE, PAR-
MA, ID:
2,536,143. REN. 2-21-12. INT. CL. 31.
- IDENTITY WORKS, INC., WEST SALEM, WI:
4,119,739, INT. CL. 42.
- IDEV TECHNOLOGIES, INC., HOUSTON, TX:
2,968,342, CANC. INT. CL. 10.
- IDEXX LABORATORIES, INC., WESTBROOK, ME:
2,467,420, CANC. MULTIPLE CLASS, INT. CLS. 35 AND
42.
- IDQ OPERATING, INC., GARLAND, TX:
4,116,658, PUB. 1-10-2012. INT. CL. 1.
- IDS PUBLISHING CORPORATION, COLUMBUS, OH:
4,117,758, PUB. 1-10-2012. INT. CL. 44.
- IDX INVESTMENT CORPORATION, SOUTH BURLING-
TON, VT:
2,968,266, CANC. MULTIPLE CLASS, INT. CLS. 9, 35, 38,
41 AND 42.
- IFW LLC, WOODLAND HILLS, CA:
4,117,895, PUB. 1-10-2012. INT. CL. 41.
- IGNEOUS GROUP, INC., THE, SANTA CRUZ, CA:
2,585,463, CANC. INT. CL. 42.
- IGNITE MEDIA SOLUTIONS, LLC, OLDSMAR, FL:
4,119,000, INT. CL. 35.
- IHARA CHEMICAL INDUSTRY CO., LTD., TOKYO, JA-
PAN:
2,561,147. REN. 2-22-12. INT. CL. 1.
- IHC HOLLAND IE B.V., NETHERLANDS:
4,116,752, PUB. 1-10-2012. MULTIPLE CLASS, INT. CLS. 7
AND 12.
- IHISPANO.COM, LLC, CHICAGO, IL:
4,118,521, PUB. 1-10-2012. MULTIPLE CLASS, INT. CLS.
35, 38, 42 AND 45.
- IHOSPITAL, LLC, TAMPA, FL:
4,119,262, MULTIPLE CLASS, INT. CLS. 35, 36, 37 AND
42.
- IHS GLOBAL SA, GENEVA, SWITZERLAND:
1,651,112. REN. 2-22-12. INT. CL. 42.
- ILEGRA CORP., MAUMEE, OH:
4,117,715, PUB. 1-10-2012. INT. CL. 42.
- ILIESCU, STEVEN A., PHILADELPHIA, PA:
2,527,660. REN. 2-22-12. INT. CL. 42.
- ILLINOIS TOOL WORKS, GLENVIEW, IL:
2,967,980, CANC. INT. CL. 42.
- ILLINOIS TOOL WORKS INC., GLENVIEW, IL:
2,525,984. REN. 2-22-12. INT. CL. 22.
2,968,467, CANC. INT. CL. 7.
- IM READY-MADE, LLC, NEW YORK, NY:
2,322,686, CANC. INT. CL. 25.
- IMAGE MEDICAL CORPORATION, GREENVILLE, SC:
2,468,246, CANC. MULTIPLE CLASS, INT. CLS. 9 AND
42.
- IMAGE X MEDIA INC., SURREY, BRITISH COLUMBIA,
CANADA:
2,967,498, CANC. MULTIPLE CLASS, INT. CLS. 9 AND
41.
- IMAGINATIK PLC, WINCHESTER, ENGLAND:
4,118,440, PUB. 1-10-2012. INT. CL. 9.
- IMBIBE MEDIA, INC., PORTLAND, OR:
4,118,940, INT. CL. 16.
- IMG WORLDWIDE, INC., CLEVELAND, OH, INTERNA-
TIONAL MANAGEMENT, INC., CLEVELAND, OH:
1,668,761. REN. 2-17-12. MULTIPLE CLASS, INT. CLS. 35
AND 36.
- IMMCO DIAGNOSTICS, INC., BUFFALO, NY:
4,117,553, PUB. 1-10-2012. INT. CL. 10.
- IMMEDIATE PETCARE, PLLC, LOUISVILLE, KY:
4,119,866, INT. CL. 44.
- IMMUNO CONCEPTS N.A., LTD, DALLAS, TX:
4,119,590, INT. CL. 9.
- IMPAC, SALEM, OR:
2,663,375. REN. 2-21-12. INT. CL. 10.
- IMPERIAL PANTS CO., LTD., ST-LAURENT, QUEBEC,
CANADA:
4,118,293, PUB. 1-10-2012. INT. CL. 25.
- IMPERIAL SUPPLIES LLC, LAKE FOREST, IL:
1,675,758. REN. 2-21-12. INT. CL. 9.
- IMPREZZIO, INC., SPOKANE, WA:
4,117,327, PUB. 1-10-2012. INT. CL. 39.
- INA ACQUISITION CORP., WILMINGTON, DE:
4,117,979, PUB. 1-10-2012. INT. CL. 37.
- INCAPSULA, INC., NES ZIONA, ISRAEL:
4,117,544, PUB. 1-10-2012. MULTIPLE CLASS, INT. CLS.
42 AND 45.
- INCODEL CORPORATION, WINDSOR, CANADA:
4,117,073, PUB. 1-10-2012. INT. CL. 7.
4,117,083, PUB. 1-10-2012. INT. CL. 7.
4,117,086, PUB. 1-10-2012. INT. CL. 7.
- INCONTACT, MIDVALE, UT:
4,119,259, INT. CL. 42.
- INCUMED, INCORPORATED, DURHAM, NC:
4,116,958, PUB. 10-4-2011. INT. CL. 42.
- INDEPENDENCE BREWING COMPANY, INC., AUSTIN,
TX:
4,118,222, PUB. 1-10-2012. INT. CL. 32.
- INDEPENDENT PILOTS ASSOCIATION, LOUISVILLE, KY:
1,671,446. REN. 2-23-12. U.S. CL. 200.
- INDIGO NETWORKS GMBH, DUESSELDORF, FED REP
GERMANY:
2,968,595, CANC. INT. CL. 38.
- INDIVIDUAL CONCEPT SA, SWITZERLAND:
4,116,680, PUB. 1-10-2012. MULTIPLE CLASS, INT. CLS.
18 AND 24.
- INFINITY CLASSICS INTERNATIONAL, INC., BROOK-
LYN, NY:
4,117,863, PUB. 1-10-2012. MULTIPLE CLASS, INT. CLS.
25 AND 35.
- INFORMA TRAINING PARTNERS LLC, WALPOLE, MA:
2,658,334. REN. 2-21-12. INT. CL. 41.

INFORMATION SECURITY CORPORATION, OAK PARK, IL:
1,738,120. REN. 2-23-12. INT. CL. 9.

INFORMED CHOICE, LLC, GREEN BAY, WI:
2,968,091. CANC. INT. CL. 41.

INFRARED DATA ASSOCIATION, INC., WALNUT CREEK, CA:
4,116,595. PUB. 1-10-2012. U.S. CL. A.

INFRASTRUCTURE CORPORATION OF AMERICA, INC., BRENTWOOD, TN:
4,118,773. MULTIPLE CLASS, INT. CLS. 9, 37 AND 42.

INGENIOUS DESIGNS LLC, ST. PETERSBURG, FL:
2,663,857. REN. 2-21-12. INT. CL. 9.

INGENIX, INC., EDEN PRAIRIE, MN:
2,551,971. REN. 2-17-12. MULTIPLE CLASS, INT. CLS. 35 AND 42.

INNCREA KIMYA MAKINA YAZILIM ELEKTRONIK SANAYI VE TICARET LIMITED SIRKETI, BESIKTAS-ISTANBUL, TURKEY:
2,968,452. CANC. INT. CL. 35.

INNOVATION VENTURES, LLC, FARMINGTON HILLS, MI:
4,116,951. PUB. 1-10-2012. MULTIPLE CLASS, INT. CLS. 5 AND 32.

INNOVATIVE COMPANIES LLC, THE, HAUPPAUGE, NY:
2,967,573. CANC. INT. CL. 19.

INNOVATIVE CONTROL SYSTEMS, INC., WIND GAP, PA:
4,119,648. INT. CL. 9.

INNOVATIVE PRODUCTS OF AMERICA, INC., WOODSTOCK, NY:
4,119,542. INT. CL. 9.

INNOVIA TECHNOLOGY LIMITED, UNITED KINGDOM:
4,116,705. PUB. 1-10-2012. MULTIPLE CLASS, INT. CLS. 35, 41, 42 AND 45.

INSIGHT PUBLICATIONS, LOS ANGELES, CA:
2,544,111. REN. 2-17-12. INT. CL. 16.
2,544,112. REN. 2-17-12. INT. CL. 16.

INSIGHT UNIVERSITY, SANTA FE, NM, GOLDEN AGE EDUCATION, INC., SANTA MONICA, CA:
1,192,311. REN. 2-21-12. INT. CL. 41.

INSITE PRODUCTIONS, LLC, DALLAS, TX, DBA INSITE INTERACTIVE:
4,117,892. PUB. 1-10-2012. MULTIPLE CLASS, INT. CLS. 35 AND 42.

INSPECTION & CONTROL SERVICES, LTD., WASHINGTON, DC:
2,468,587. CANC. INT. CL. 42.

INSPIRED INSTRUMENTS, INC., CHATSWORTH, CA:
4,117,036. PUB. 1-10-2012. INT. CL. 15.

INSTITUTE FOR SCHOOL EXCELLENCE, INDIANAPOLIS, IN:
4,117,717. PUB. 1-10-2012. INT. CL. 35.
4,119,705. INT. CL. 41.

INSTANET, INC., NEW YORK, NY:
2,967,319. CANC. INT. CL. 9.

INSULATED GLASS OF AMERICA, INC, DALLAS, NC:
4,117,842. PUB. 1-10-2012. INT. CL. 19.

INSURANCE BROWSER INC., DECATUR, GA:
4,117,872. PUB. 1-10-2012. INT. CL. 36.

INTECH INVESTMENT MANAGEMENT LLC, WEST PALM BEACH, FL:
4,117,125. PUB. 1-10-2012. INT. CL. 36.

INTEGRATECHS, INC., AMERICAN FORK, UT:
4,118,203. PUB. 1-10-2012. MULTIPLE CLASS, INT. CLS. 37 AND 42.
4,118,204. PUB. 1-10-2012. MULTIPLE CLASS, INT. CLS. 37 AND 42.
4,118,205. PUB. 1-10-2012. INT. CL. 42.
4,118,206. PUB. 1-10-2012. INT. CL. 42.

INTEGRATED CONTROL SYSTEMS, INC., PUNTA GORDA, FL:
2,467,638. CANC. INT. CL. 41.

INTEGRATED DEVICE TECHNOLOGY, INC., SANTA CLARA, CA:
2,967,484. CANC. INT. CL. 9.

INTEGRATION 4.0 INC., CUMMING, GA:
2,968,299. CANC. INT. CL. 42.

INTEGRIS WEALTH MANAGEMENT, LLC, CARMEL, CA:
4,117,186. PUB. 1-10-2012. INT. CL. 36.

INTEGRITY LIFE INSURANCE COMPANY, CINCINNATI, OH, INTEGRITY LIFE INSURANCE COMPANY, CINCINNATI, OH:
2,564,119. REN. 2-22-12. INT. CL. 36.

INTELIMEDIX LLC, LAKE LAND, PA, AKA IMX:
4,118,598. PUB. 1-10-2012. INT. CL. 42.

INTELLISTRY INFORMATION SYSTEMS, INC., IRVINE, CA, DBA GEO.TO:
4,119,786. INT. CL. 35.
4,119,787. MULTIPLE CLASS, INT. CLS. 35 AND 42.

INTELLITOONZ ENTERTAINMENT LLC, HILLSBOROUGH, NJ:
4,119,118. INT. CL. 25.

INTEPLAST GROUP, LTD., LIVINGSTON, NJ:
4,119,190. INT. CL. 19.
4,119,191. INT. CL. 19.

INTERCONNECTIONS TRAVEL INC., SAN LUIS OBISPO, CA, FRASER, LAURA W., SAN LUIS OBISPO, CA, DBA ADOBE TRAVEL AND DBA TOUR/COSTA RICA CONNECTION:
1,696,519. REN. 2-22-12. INT. CL. 39.

INTEREST NETWORKS, LLC, PRIOR LAKE, MN:
4,117,745. PUB. 1-10-2012. MULTIPLE CLASS, INT. CLS. 35 AND 41.

INTERNATIONAL AIDS SOCIETY-USA, SAN FRANCISCO, CA:
4,119,764. INT. CL. 16.

INTERNATIONAL ASSAYING SERVICES AND SUPPLIES, INC., COSTA MESA, CA:
4,119,813. INT. CL. 1.

INTERNATIONAL BANCARD CORPORATION, CLAWSON, MI:
4,117,634. PUB. 1-10-2012. MULTIPLE CLASS, INT. CLS. 9 AND 36.

INTERNATIONAL BILDRITE, INC., INTERNATIONAL FALLS, MN:
4,117,206. PUB. 1-10-2012. INT. CL. 19.
4,117,208. PUB. 1-10-2012. INT. CL. 19.
4,117,209. PUB. 1-10-2012. INT. CL. 19.
4,117,210. PUB. 1-10-2012. INT. CL. 19.
4,117,211. PUB. 1-10-2012. INT. CL. 19.

INTERNATIONAL BUSINESS MACHINES CORPORATION, ARMONK, NY, AKA IBM CORPORATION:
2,968,630. CANC. MULTIPLE CLASS, INT. CLS. 9 AND 42.

INTERNATIONAL CODE COUNCIL, INC., WHITTIER, CA:
4,116,880. PUB. 1-10-2012. MULTIPLE CLASS, INT. CLS. 9, 41 AND 42.
4,116,881. PUB. 1-10-2012. MULTIPLE CLASS, INT. CLS. 9, 41 AND 42.

INTERNATIONAL COMMUNITY OF CHRIST, RENO, NV:
2,467,506. CANC. MULTIPLE CLASS, INT. CLS. 16, 41 AND 42.

INTERNATIONAL CONTRACT FURNISHINGS, INC., NORWOOD, NJ:
1,689,072. REN. 2-23-12. INT. CL. 20.

INTERNATIONAL DATA GROUP, INC., FRAMINGHAM, MA:
2,627,455. REN. 2-22-12. INT. CL. 41.
4,119,765. INT. CL. 35.

INTERNATIONAL FABRICS, INC., GREENSBORO, NC:
2,539,371. REN. 2-19-12. INT. CL. 24.
2,539,371. CANC. INT. CL. 35.

INTERNATIONAL FOODSTUFFS CO, P.O. BOX 4115 SHARJAH, UNITED ARAB EMIR.:
2,467,010. CANC. INT. CL. 30.

INTERNATIONAL MASTERS PUBLISHERS AB, MALMO, SWEDEN:
4,117,748. PUB. 1-10-2012. INT. CL. 38.

INTERNATIONAL ODDITIES, INC., ROLLING HILLS, CA:
4,117,184. PUB. 6-21-2011. INT. CL. 34.

INTERNATIONAL PACIFIC SEAFOODS, INC., CITY OF INDUSTRY, CA:
2,467,716. CANC. INT. CL. 35.

INTERNATIONAL PAPER COMPANY, MEMPHIS, TN:
4,119,339. INT. CL. 41.

- INTERNATIONAL PROJECTS, INC., HOLLAND, OH:
2,546,286. REN. 2-19-12. INT. CL. 16.
- INTERNATIONAL SNOWMOBILE MANUFACTURERS ASSOCIATION, HASLETT, MI:
2,968,629, CANC. INT. CL. 35.
- INTERNATIONAL SOCIETY OF PRIMERUS LAW FIRMS, LTD., THE, GRAND RAPIDS, MI:
4,117,128, PUB. 1-10-2012. INT. CL. 35.
- INTERNATIONAL SPECIALTIES CO., LTD., JORDAN, HONG KONG:
4,119,355, MULTIPLE CLASS, INT. CLS. 5 AND 10.
- INTERNATIONAL STAR CLASS YACHT RACING ASSOCIATION, ANNAPOLIS, MD:
4,117,455, PUB. 1-10-2012. INT. CL. 41.
- INTERNATIONAL TRAINING, LLC, CARSON CITY, NV, TA E0431752007-1:
2,967,846, CANC. INT. CL. 41.
- INTERNATIONAL VENTING MANAGEMENT, INC., INDIANAPOLIS, IN:
4,119,503, INT. CL. 35.
4,119,558, INT. CL. 35.
- INTERNATIONAL BUSINESS MACHINES CORPORATION, ARMONK, NY, AKA IBM CORPORATION:
4,118,823, INT. CL. 9.
- INTERNET LAW AND POLICY FORUM, SEATTLE, WA:
2,968,043, CANC. MULTIPLE CLASS, INT. CLS. 35 AND 41.
- INTERNET SECURITIES, OAKLAND, CA:
2,967,340, CANC. INT. CL. 36.
- INTERPOOL, INC., PRINCETON, NJ:
4,118,233, PUB. 1-10-2012. INT. CL. 37.
- INTERVET INTERNATIONAL B.V., BOXMEER, NETHERLANDS:
4,119,361, INT. CL. 5.
- INTERVIDEO, INC., FREMONT, CA:
2,979,750, CANC. INT. CL. 9.
- INTRYCA, INC., SANTA BARBARA, CA:
4,119,316, INT. CL. 9.
- INTUNE CORPORATION, VENTURA, CA:
2,468,288, CANC. INT. CL. 21.
- INVENSYS SYSTEMS, INC., FOXBORO, MA:
2,664,533. REN. 2-22-12. INT. CL. 9.
- INVENTEC CORPORATION, SHIH LIN DISTRICT, TAIPEI, TAIWAN:
2,968,119, CANC. MULTIPLE CLASS, INT. CLS. 9, 16, 35, 41 AND 42.
- INVENTIO AG, SWITZERLAND:
4,116,774, PUB. 1-10-2012. MULTIPLE CLASS, INT. CLS. 7, 9 AND 37.
- INVESTING IN YOUR DESTINY, LLC, AUSTIN, TX:
4,118,958, INT. CL. 35.
- INVICTA WATCH COMPANY OF AMERICA, INC., HOLLYWOOD, FL:
4,118,324, PUB. 1-10-2012. INT. CL. 14.
- INVIRO MEDICAL DEVICES LTD., BRIDGETOWN, BARBADOS:
2,967,982, CANC. INT. CL. 10.
- INVIVOSCRIBE TECHNOLOGIES, INC., SAN DIEGO, CA:
4,119,105, MULTIPLE CLASS, INT. CLS. 1 AND 5.
4,119,108, MULTIPLE CLASS, INT. CLS. 1 AND 5.
4,119,135, MULTIPLE CLASS, INT. CLS. 42 AND 44.
4,119,136, MULTIPLE CLASS, INT. CLS. 42 AND 44.
- INWELL, INC., HOUSTON, TX:
2,467,809, CANC. INT. CL. 37.
- IN2VATE, L.L.C., TULSA, OK:
4,117,766, PUB. 1-10-2012. MULTIPLE CLASS, INT. CLS. 35, 41, 42 AND 45.
- IOTA SOLUTIONS, INC., GRAYSON, GA:
2,467,904, CANC. INT. CL. 42.
- IOTTA SHOP! PRODUCTIONS, LLC, FORT WAYNE, IN, DBA IOTTA SHOP!:
2,968,351, CANC. MULTIPLE CLASS, INT. CLS. 14, 16, 21 AND 25.
- IOWA STATE UNIVERSITY OF SCIENCE AND TECHNOLOGY, AMES, IA:
4,117,362, PUB. 8-9-2011. MULTIPLE CLASS, INT. CLS. 25 AND 41.
- IPINION LLC, COLUMBUS, OH:
4,117,521, PUB. 1-10-2012. INT. CL. 35.
- IPMA INTERNATIONAL PROJECT MANAGEMENT ASSOCIATION, SWITZERLAND:
4,116,859, PUB. 1-10-2012. MULTIPLE CLASS, INT. CLS. 35 AND 42.
- IRBY, JOSEPH A., LITTLE ROCK, AR, DBA BESTQUEST TEACHING SYSTEMS:
2,967,571, CANC. INT. CL. 41.
- IRIDIUM SATELLITE LLC, MCLEAN, VA:
4,118,641, PUB. 1-10-2012. MULTIPLE CLASS, INT. CLS. 9 AND 38.
- IRON GM, LLC, DUPONT, WA:
4,118,039, PUB. 1-10-2012. INT. CL. 41.
- IRONCLAD PERFORMANCE WEAR CORP., EL SEGUNDO, CA:
4,118,713, PUB. 1-10-2012. INT. CL. 21.
- IROQUOIS GROUP INC., OLEAN, NY:
4,119,773, INT. CL. 36.
- ISA AUCTIONATA AUKTIONEN AG, VIENNA, AUSTRIA:
4,117,266, PUB. 1-10-2012. MULTIPLE CLASS, INT. CLS. 35, 42 AND 45.
- ISAAC REMY LAURENT I.R.L LLC, TROY, MI:
4,117,793, PUB. 1-10-2012. INT. CL. 41.
- ISCA TECHNOLOGIES, INC., RIVERSIDE, CA:
4,119,687, MULTIPLE CLASS, INT. CLS. 5 AND 21.
- ISEE MEDIA, INC., CONCORD, ONTARIO, CANADA:
2,967,339, CANC. INT. CL. 9.
- ISHIGAKI COMPANY LIMITED, TOKYO, JAPAN:
2,556,421. REN. 2-17-12. INT. CL. 12.
- ISLAND POLYETHYLENE BAG & SUPPLY CORP., WESTBURY, NY:
2,273,051, COR. INT. CL. 21.
- ISOFEM INTERNATIONAL, MANNVILLE, ALBERTA:
2,893,704, CANC. INT. CL. 28.
- ISSUES & ANSWERS NETWORK, INC., VIRGINIA BEACH, VA:
4,116,941, PUB. 1-10-2012. INT. CL. 35.
- ISYS SOLUTIONS, INC., BUENA PARK, CA:
4,118,530, PUB. 1-10-2012. INT. CL. 41.
4,118,532, PUB. 1-10-2012. INT. CL. 41.
4,118,533, PUB. 1-10-2012. INT. CL. 41.
- ITC LIMITED, KOLKATA, INDIA:
4,116,615, PUB. 1-10-2012. INT. CL. 3.
- IVANKO BARBELL COMPANY, SAN PEDRO, CA:
4,116,579, PUB. 1-10-2012. INT. CL. 28.
- IVENS CORPORATION, THE, MIAMI BEACH, FL:
1,686,323. REN. 2-22-12. INT. CL. 14.
- IVX ANIMAL HEALTH, INC., ST. JOSEPHS, MO:
2,967,895, CANC. INT. CL. 10.
- IWAN SIMONIS, INC., LIBERTYVILLE, IL:
4,119,156, INT. CL. 24.
4,119,157, INT. CL. 24.
- IWAN SIMONIS, INC., ARLINGTON HEIGHTS, IL:
4,119,158, INT. CL. 24.
- IXIA, CALABASAS, CA:
4,119,489, INT. CL. 9.
- IXL LEARNING, INC., SAN MATEO, CA:
4,117,223, PUB. 1-10-2012. INT. CL. 41.
4,117,323, PUB. 1-10-2012. INT. CL. 41.
- J & G INFINITY, INC., WORTH, IL:
2,468,489, CANC. INT. CL. 16.
- J & R DEBENEDETTO ORCHARDS, INC., CHOWCHILLA, CA:
4,117,838, PUB. 1-10-2012. INT. CL. 31.
- J & S DISTRIBUTORS, INC., SAINT CHARLES, MO, DBA ACI DISTRIBUTORS, INC.:
2,967,764, CANC. INT. CL. 7.
- J. & M. MANUFACTURING CO. INC., FORT RECOVERY, OH:
1,694,237. REN. 2-22-12. INT. CL. 12.
- J. & P. COATS, LIMITED, GLASGOW, SCOTLAND:
290,958. REN. 2-23-12. U.S. CL. 43 (INT. CL. 23).
- J. BAXTER BRINKMANN INTERNATIONAL CORPORATION, DALLAS, TX:
4,116,906, PUB. 1-10-2012. INT. CL. 9.
4,116,907, PUB. 1-10-2012. INT. CL. 11.
4,116,908, PUB. 1-10-2012. INT. CL. 20.

J. HOWARD, LLC, NORTH BEND, OR:
4,117,798, PUB. 1-10-2012. INT. CL. 11.

J. J. WHITE PRODUCTS, INC., CLEVELAND, OH:
2,466,907, CANC. INT. CL. 1.

J. MARPLE PUBLISHING, LLC, BARTLETT, TN:
4,117,534, PUB. 1-10-2012. INT. CL. 16.

J.D. NEUHAUS LIMITED PARTNERSHIP, SPARKS, MD:
4,117,713, PUB. 1-10-2012. INT. CL. 7.

J.E.P. CONTRACTING, INC., MILLBURY, MA:
4,118,048, PUB. 1-10-2012. INT. CL. 37.

J.R. SIMPLOT COMPANY, BOISE, ID, CARNATION COMPANY, LOS ANGELES, CA:
1,187,914. REN. 2-23-12. INT. CL. 29.

JABIAN, LLC, ATLANTA, GA:
4,118,655, PUB. 1-10-2012. INT. CL. 35.
4,118,656, PUB. 1-10-2012. INT. CL. 42.
4,118,658, PUB. 1-10-2012. INT. CL. 35.
4,118,659, PUB. 1-10-2012. INT. CL. 42.

JACK GRAHAM, INC., SARASOTA, FL:
2,584,982. REN. 2-17-12. MULTIPLE CLASS, INT. CLS. 39 AND 42.

JACK HENRY SOFTWARE/COMMLINK, L.P., MONETT, MO:
2,967,777, CANC. INT. CL. 9.

JACK RABBIT USA, LLC, PENSACOLA, FL:
4,117,889, PUB. 1-10-2012. INT. CL. 37.

JACUZZI, MATTHEW, CROCKETT, CA:
4,117,114, PUB. 1-10-2012. INT. CL. 25.

JAKE SHIELDS, INC., ARNOLD, CA:
4,119,132, MULTIPLE CLASS, INT. CLS. 25 AND 41.

JAKE'S JOINT, INC., RICHARDSON, TX:
4,119,470, INT. CL. 43.

JAKKS PACIFIC, INC., MALIBU, CA:
2,464,572. REN. 2-21-12. INT. CL. 28.

JAM INDUSTRIES LTD./LTEE, QUEBEC H9X 4B7, CANADA:
4,119,185, MULTIPLE CLASS, INT. CLS. 9 AND 15.

JAMES BAHCALL, BUFFALO GROVE, IL:
4,119,182, INT. CL. 3.

JAMES HARDIE TECHNOLOGY LIMITED, DUBLIN 2, IRELAND:
4,119,225, INT. CL. 19.

JAMIE LYNN MARKETING LLC, NORTH CHICAGO, IL:
2,522,172. REN. 2-21-12. MULTIPLE CLASS, INT. CLS. 4, 8, 16, 18, 20 AND 21.

JANET MARTIN CONSULTING, INC, MISSION VIEJO, CA:
4,116,973, PUB. 1-10-2012. INT. CL. 36.

JANUS ET CIE, WEST HOLLYWOOD, CA:
4,117,458, PUB. 1-10-2012. INT. CL. 18.
4,117,460, PUB. 1-10-2012. INT. CL. 20.
4,117,461, PUB. 1-10-2012. INT. CL. 22.

JANUSFABRIKKEN AS, 5267 ESPELAND, NORWAY:
4,118,531, PUB. 1-10-2012. INT. CL. 25.

JAPAN AIRLINES CO., LTD., TOKYO, JAPAN:
1,681,643. REN. 2-21-12. INT. CL. 39.

JARAGON MANAGEMENT, LLC, FT. WALTON BEACH, FL:
4,118,075, PUB. 1-10-2012. INT. CL. 41.

JARROW FORMULAS, INC., LOS ANGELES, CA:
2,523,471. REN. 2-22-12. INT. CL. 5.

JASMIN, JULIE R., WHITE RIVER JUNCTION, VT:
2,967,917, CANC. INT. CL. 3.

JASON SANDS, VALLEY VILLAGE, CA:
4,118,304, PUB. 1-10-2012. INT. CL. 44.

JAY AT PLAY INTERNATIONAL HONG KONG LIMITED, HONG KONG, CHINA:
4,118,768, INT. CL. 28.

JAZETTE ENTERPRISES LIMITED, CONTIGUO YOUNG ANN, COSTA RICA:
4,117,143, PUB. 1-10-2012. MULTIPLE CLASS, INT. CLS. 9, 36 AND 41.

JAZZERCISE, INC., CARLSBAD, CA:
2,668,728. REN. 2-22-12. INT. CL. 41.

JDV MARK CO, S.A.P.I. DE C.V., MUNICIPIO DE TEPOTZOTLAN, EDO. DE MEXICO, MEXICO:
2,967,491, CANC. INT. CL. 32.

JEAH COMMUNICATIONS, LLC, MENOMONEE FALLS, WI, JEAH COMMUNICATIONS, LLC, MENOMONEE FALLS, WI:
2,661,650. REN. 2-22-12. INT. CL. 42.

JEFF WATTS, OKLAHOMA CITY, OK:
4,117,338, PUB. 1-10-2012. INT. CL. 30.

JEFFREY BISCHOFF, LEHI, UT:
4,119,663, INT. CL. 25.

JEFIT INC., CARY, NC:
4,117,747, PUB. 1-10-2012. INT. CL. 9.

JELLE OOMES, IBIZA, SPAIN:
4,117,102, PUB. 1-10-2012. MULTIPLE CLASS, INT. CLS. 9 AND 41.

JELMAR, LLC, SKOKIE, IL:
4,118,173, PUB. 1-10-2012. INT. CL. 3.
4,118,174, PUB. 1-10-2012. INT. CL. 3.
4,118,736, PUB. 1-10-2012. INT. CL. 3.
4,118,737, PUB. 1-10-2012. INT. CL. 3.

JENNEREX, INC., SAN FRANCISCO, CA:
4,119,491, INT. CL. 5.

JENNIFER C. SANT'ANNA, SAN JOSE, CA:
4,118,833, INT. CL. 35.

JENSEN, RACHELLE, LOS ANGELES, CA:
2,967,922, CANC. INT. CL. 41.

JERICO SYSTEMS CORPORATION, DALLAS, TX:
4,118,503, PUB. 1-10-2012. INT. CL. 9.

JERRS PLUS, INC., NEW YORK, NY:
2,967,765, CANC. MULTIPLE CLASS, INT. CLS. 26 AND 28.

JERRY DUPLESSIS, NEW YORK, NY:
4,117,214, PUB. 1-10-2012. INT. CL. 9.

JESSICA LONDON, INC., INDIANAPOLIS, IN:
2,645,682. REN. 2-21-12. INT. CL. 35.

JETBRAINS S.R.O., PRAGUE 4, 147 00, CZECH REPUBLIC:
4,118,352, PUB. 1-10-2012. INT. CL. 9.
4,118,353, PUB. 1-10-2012. INT. CL. 9.

JETDIRECT AVIATION, LLC, BERWYN, PA:
2,968,132, CANC. INT. CL. 39.

JFC, INC., ST. CLOUD, MN:
4,118,687, PUB. 1-10-2012. INT. CL. 29.

JHC RISK STRATEGIES, LLC, WILLISTON, VT:
4,117,885, PUB. 1-10-2012. INT. CL. 35.

JIM'S ORIGINAL INCORPORATED, CHICAGO, IL:
4,117,535, PUB. 1-10-2012. INT. CL. 43.

JIMENEZ AYUD, ANTONIO, TORREMOLINOS, MALAGA, SPAIN, DBA JIMENEZ AYUD, ANTONIO:
4,118,968, INT. CL. 25.

JIMLAR CORPORATION, GREAT NECK, NY:
2,967,499, CANC. INT. CL. 25.

JIMMY LOPEZ, JR., AUSTIN, TX:
4,119,564, INT. CL. 43.

JIN HONG EU, TAMPA, FL:
4,119,661, INT. CL. 28.

JINAN PROPLUS ELECTRONICS CO. LTD., JINAN, CHINA, DBA KHAI-LONG PROPLUS:
4,117,635, PUB. 1-10-2012. INT. CL. 9.

JINAN XINLEI PRECISION MACHINERY CO., LTD., JINAN CITY; 250108 SHANDONG PROVINCE, CHINA:
4,116,727, PUB. 1-10-2012. MULTIPLE CLASS, INT. CLS. 7, 9 AND 19.

JINTOWN ENTERPRISE LTD., CONNAUGHT WEST, HONG KONG:
2,967,746, CANC. INT. CL. 29.

JLS INTERACTIVE, LLC, LINCOLN, NE:
4,092,567, COR. INT. CL. 41.

JNBA FINANCIAL ADVISORS, INC., MINNEAPOLIS, MN:
2,966,149, CANC. INT. CL. 36.

JOAN SINGER, NEW YORK, NY:
4,119,649, INT. CL. 41.

JOANNA MENDELSON AND DEBI BAER PARTNERSHIP, THE, LOS ANGELES, CA:
2,967,702, CANC. INT. CL. 24.

JOBAR INTERNATIONAL, INC., CARSON, CA:
1,678,366. REN. 2-21-12. INT. CL. 9.

JOHN A. VAN DEN BOSCH COMPANY, HOLLAND, MI, MARTIN'S FEED MILLS, INC., NEW PARIS, IN:
1,687,291. REN. 2-17-12. INT. CL. 31.

- JOHN AUGUST MEDIA, LLC, BAINBRIDGE ISLAND, WA:
4,119,810, INT. CL. 41.
- JOHN B. SANFILIPPO & SON, INC., ELGIN, IL:
4,119,463, MULTIPLE CLASS, INT. CLS. 16, 18, 25, 29
AND 30.
- JOHN HANCOCK LIFE INSURANCE COMPANY (U.S.A.),
BOSTON, MA:
4,118,612, PUB. 1-10-2012. INT. CL. 41.
- JOHN MEUNIER INC., MONTREAL, (QUEBEC), CANADA:
2,542,069. REN. 2-22-12. INT. CL. 11.
- JOHN MEZZALINGUA ASSOCIATES, INC., EAST SYRA-
CUSE, NY, DBA PPC:
4,118,984, INT. CL. 9.
- JOHN RICH & SONS INVESTMENT HOLDING COMPANY,
WILMINGTON, DE:
2,968,508, CANC. INT. CL. 24.
- JOHN THOR, DAYTONA BEACH, FL:
4,117,976, PUB. 1-10-2012. INT. CL. 5.
- JOHN WILEY & SONS, INC., HOBOKEN, NJ:
2,468,822. REN. 2-22-12. INT. CL. 16.
- JOHNSON & JOHNSON, NEW BRUNSWICK, NJ, LAMBERT
PHARMACAL COMPANY, ST. LOUIS, MO:
85,150. REN. 2-22-12. U.S. CL. 18 (INT. CL. 5).
- JOHNSON & JOHNSON, NEW BRUNSWICK, NJ:
922,218. REN. 2-22-12. U.S. CL. 18 (INT. CL. 5).
2,968,496, CANC. INT. CL. 5.
4,118,952, INT. CL. 5.
4,118,993, INT. CL. 5.
4,119,139, INT. CL. 3.
4,119,140, INT. CL. 3.
- JOHNSON CONTROLS, INC., MILWAUKEE, WI, PENN
ELECTRIC SWITCH CO., GOSHEN, IN:
555,220. REN. 2-21-12. U.S. CL. 21 (INT. CL. 9).
- JOHNSON, FRANKLIN, MINCOLA, NY:
2,564,230. REN. 2-17-12. INT. CL. 42.
- JOHNSONITE INC., CHAGRIN FALLS, OH:
2,536,716. REN. 2-22-12. INT. CL. 19.
- JONES, ANNIE L, AUSTIN, TX, DBA ROCK CANDY
MEDIA:
4,118,160, PUB. 1-10-2012. INT. CL. 16.
- JONES, ROBERT W., VIENNA, VA:
4,118,323, PUB. 1-10-2012. INT. CL. 19.
- JONMOR INVESTMENTS, INC., WILMINGTON, DE:
1,161,164. REN. 2-22-12. INT. CL. 29.
2,968,425, CANC. INT. CL. 29.
- JORDAN RIVER MOVING L.L.C., KIRKLAND, WA:
4,117,891, PUB. 1-10-2012. INT. CL. 35.
- JORDAN, J. CLIVE, BOISE, ID:
4,116,938, PUB. 1-10-2012. MULTIPLE CLASS, INT. CLS.
25 AND 35.
- JORDCO, INC., BEAVERTON, OR:
4,116,975, PUB. 1-10-2012. INT. CL. 10.
4,116,976, PUB. 1-10-2012. INT. CL. 10.
- JOSEPH CIOLLI, TEMPE, AZ:
4,117,397, PUB. 1-10-2012. INT. CL. 43.
- JOSEPH J. IANELLI 3RD, STATEN ISLAND, NY:
4,116,629, PUB. 1-10-2012. INT. CL. 25.
- JOSEPH MILLER, LOS ANGELES, CA:
4,117,849, PUB. 1-10-2012. MULTIPLE CLASS, INT. CLS.
35 AND 45.
- JOSIFA INTERNATIONAL INC., PLANO, TX:
4,118,579, PUB. 1-10-2012. INT. CL. 5.
- JOURNELLA, LLC, WILLIAMSBURG, VA:
4,119,443, INT. CL. 42.
- JOVANI FASHION, LTD, NEW YORK, NY:
4,116,887, PUB. 1-10-2012. INT. CL. 25.
- JOWAT AG, DETMOLD, FED REP GERMANY:
1,193,467. REN. 2-17-12. INT. CL. 1.
- JOYENT, INC., SAN FRANCISCO, CA:
4,117,313, PUB. 1-10-2012. INT. CL. 42.
- JPMORGAN CHASE & CO., NEW YORK, NY:
717,320. REN. 2-17-12. U.S. CL. 102 (INT. CL. 36).
2,651,489. REN. 2-21-12. INT. CL. 36.
2,967,736, CANC. INT. CL. 36.
- JS IP LLC, AVENTURA, FL:
4,119,072, INT. CL. 25.
- JS REHL PRODUCTIONS, CHICAGO, IL:
4,117,344, PUB. 1-10-2012. INT. CL. 25.
- JSMG WORLDWIDE, INC., MIRAMAR, FL:
4,117,729, PUB. 1-10-2012. INT. CL. 9.
- JSR CORPORATION, MINATO-KU, TOKYO, JAPAN:
4,117,571, PUB. 1-10-2012. MULTIPLE CLASS, INT. CLS. 1
AND 2.
- JU.CLA.S.-S.R.L., PESCANTINA (VR), ITALY:
2,527,155. REN. 2-21-12. INT. CL. 42.
- JULIE DAVIS, DALLAS, TX:
4,117,697, PUB. 1-10-2012. INT. CL. 41.
- JULIE M DALEY, BERKELEY, CA, DBA CREATIVE WELL-
SPRING:
4,116,934, PUB. 1-10-2012. INT. CL. 41.
- JULIEN VAN DER VALK, H.O.D.N. GLOBAL SPIRIT
COMPANY, NETHERLANDS:
4,116,800, PUB. 1-10-2012. INT. CL. 33.
- JULIET STOREY, CHICAGO, IL:
4,117,121, PUB. 1-10-2012. INT. CL. 41.
4,117,494, PUB. 1-10-2012. INT. CL. 41.
- JUMP 23, INC., CHICAGO, IL:
2,547,960. REN. 2-21-12. INT. CL. 42.
2,598,522. REN. 2-19-12. MULTIPLE CLASS, INT. CLS. 6,
21 AND 25.
- JUMPSOFT INC, VIENNA, VA:
4,118,950, INT. CL. 9.
- JUNGPFLANZEN GRÜNEWALD GMBH, FED REP GER-
MANY:
4,116,824, PUB. 1-10-2012. INT. CL. 31.
- JUNIOR LEARNING, INC., HUNTINGTON BEACH, CA:
4,118,076, PUB. 1-10-2012. INT. CL. 28.
- JUNIOR SEAU FOUNDATION, SAN DIEGO, CA:
2,618,095. REN. 2-22-12. INT. CL. 42.
- JUNIPER NETWORKS, INC., SUNNYVALE, CA:
4,118,939, MULTIPLE CLASS, INT. CLS. 9, 37, 41 AND 42.
- JURA, CLIFTON P., GRAND RAPIDS, MI, DBA AD-
VANCED WHIZNOLOGY:
4,117,817, PUB. 1-10-2012. INT. CL. 30.
- JUSTIN JACKSON, JENKS, OK:
4,088,285, COR. MULTIPLE CLASS, INT. CLS. 9 AND 28.
- JUSTINE BATEMAN DESIGNS, INC., STUDIO CITY, CA:
2,467,537, CANC. INT. CL. 25.
- JUTHANI, NALINI, SCARSDALE, NY AND COX, KATH-
LEEN, N., GREENWICH, CT:
2,968,500, CANC. INT. CL. 41.
- JWC ENVIRONMENTAL, LLC, COSTA MESA, CA:
1,671,349. REN. 2-21-12. MULTIPLE CLASS, INT. CLS. 37
AND 42.
- JYE TAI PRECISION INDUSTRIAL CO., LTD., NEW TAIPEI
CITY 241, TAIWAN:
4,117,111, PUB. 1-10-2012. INT. CL. 9.
- J2 GLOBAL, INC., HOLLYWOOD, CA:
2,644,821. REN. 2-22-12. INT. CL. 38.
- K & E CHEMICAL COMPANY, INC., CLEVELAND, OH:
1,675,658. REN. 2-21-12. INT. CL. 3.
- K. HALL STUDIO INC., BRENTWOOD, MO:
4,118,250, PUB. 1-10-2012. MULTIPLE CLASS, INT. CLS. 3
AND 4.
- K.M.A. SUNBELT TRADING CORPORATION, CLEAR-
WATER, FL:
4,117,941, PUB. 1-10-2012. INT. CL. 35.
- K-SWISS INC., WESTLAKE VILLAGE, CA:
2,467,835, CANC. INT. CL. 9.
- KABUSHIKI KAISHA JUNCTION PRODUCE, KAWACHI-
NAGANO CITY, OSAKA PREF., JAPAN:
2,967,707, CANC. INT. CL. 12.
- KABUSHIKI KAISHA NTT DATA, TOKYO, JAPAN, DBA
NTT DATA CORPORATION:
4,116,877, PUB. 1-10-2012. MULTIPLE CLASS, INT. CLS.
9, 37, 38 AND 42.
- KABUSHIKI KAISHA RIKIO, CHUO-KU, TOKYO, JAPAN:
1,670,326. REN. 2-21-12. INT. CL. 25.
1,671,190. REN. 2-21-12. INT. CL. 25.
1,671,192. REN. 2-21-12. INT. CL. 25.
- KABUSHIKI KAISHA SEGA, TOKYO, JAPAN, DBA SEGA
CORPORATION:
2,967,737, CANC. INT. CL. 9.

KAHN LUCAS LANCASTER, INC., NEW YORK, NY:
4,118,706, PUB. 1-10-2012. INT. CL. 25.
4,118,965, INT. CL. 25.
4,119,308, INT. CL. 25.

KALA HEALTH ENRICHMENT, INC. FALMOUTH, MA,
DBA KALA HEALTH:
4,118,086, PUB. 1-10-2012. INT. CL. 5.

KALO, INC., OVERLAND PARK, KS:
2,537,828. REN. 2-22-12. INT. CL. 1.

KAMAGAMES LTD, LIMASSOL, CYPRUS:
4,118,295, PUB. 1-10-2012. INT. CL. 42.
4,118,296, PUB. 1-10-2012. INT. CL. 42.

KANBAR ENTERTAINMENT, LLC, SAN FRANCISCO, CA:
4,118,921, INT. CL. 9.

KANDI KOATED ENTERTAINMENT, INC., ATLANTA, GA:
4,119,671, INT. CL. 10.

KANEKO, OMAHA, NE:
4,118,578, PUB. 1-10-2012. INT. CL. 41.
4,118,608, PUB. 1-10-2012. INT. CL. 41.

KANGWONGFU INTERNATIONAL CO., LTD., TAIPEI
CITY, TAIWAN:
4,118,362, PUB. 1-10-2012. INT. CL. 3.

KANNER, STEVEN, SAVANNAH, GA:
4,119,805, INT. CL. 35.

KANSA TECHNOLOGY, LLC, EMPORIA, KS, KANSA
CORPORATION, EMPORIA, KS:
1,167,165. REN. 2-21-12. INT. CL. 12.

KANTAR HEALTH INC., NEW YORK, NY:
2,528,025. REN. 2-22-12. INT. CL. 9.

KAO KABUSHIKI KAISHA, TOKYO, JAPAN, TA KAO
CORPORATION:
2,468,506, CANC. INT. CL. 2.

KAPALUA LAND COMPANY, LTD., LAHAINA, HI:
4,116,551, PUB. 1-10-2012. INT. CL. 25.

KAPLAN DEVELOPMENT GROUP, LLC, JERICHO, NY:
4,118,456, PUB. 1-10-2012. INT. CL. 43.

KAPRAL, PATRICIA A., KEARNEY, MO, DBA HUGS BY
PAT:
2,467,372, CANC. INT. CL. 28.

KAREN R LANE, LINCOLN, ME, DBA SACKFULLA:
4,118,634, PUB. 1-10-2012. INT. CL. 18.

KAREN ROBERTS, SOUTHWICK, MA:
4,119,733, INT. CL. 5.

KARL MAYER TEXTILMASCHINENFABRIK GMBH, D-
63179 OBERTSHAUSEN, FED REP GERMANY:
3,058,401, CANC. MULTIPLE CLASS, INT. CLS. 9, 10, 12,
17, 19, 22, 24, 25, 28 AND 42.

KARL WERKMEISTER, MEDIZINISCHE LEIBBINDEN,
INH., HANS-JÜRGEN GERMERODT, FED REP GER-
MANY:
4,116,766, PUB. 1-10-2012. INT. CL. 5.

KARLEN KLEINKOPF, RIVER FOREST, IL, DBA WHAT TO
WEAR GUIDES:
4,119,860, INT. CL. 42.

KARSTEN MANUFACTURING CORP., PHOENIX, AZ:
1,738,453. REN. 2-21-12. INT. CL. 28.

KARSTEN MANUFACTURING CORPORATION, PHOE-
NIX, AZ:
4,118,380, PUB. 1-10-2012. INT. CL. 9.

KARTER, KIMBERLY B., LEVITTOWN, NY:
4,117,930, PUB. 1-10-2012. INT. CL. 41.

KARYN'S FRESH CORNER CAFE, INC., CHICAGO, IL:
4,116,603, PUB. 1-10-2012. INT. CL. 3.
4,116,604, PUB. 1-10-2012. INT. CL. 5.

KASPERSKY LAB ZAO, RUSSIAN FED.:
4,116,775, PUB. 1-10-2012. MULTIPLE CLASS, INT. CLS.
9, 16, 35 AND 42.

KASSA, MARK, WEST BLOOMFIELD, MI:
4,117,605, PUB. 1-10-2012. INT. CL. 41.

KASTALON, INC., ALSIP, IL:
4,117,860, PUB. 1-10-2012. MULTIPLE CLASS, INT. CLS. 6
AND 7.

KASTLE KREAM DOUGHNUTS CORP, HOOVER, AL, TA
KASTLE KREAM DOUGHNUTS:
4,117,308, PUB. 1-10-2012. INT. CL. 30.

KASTLE KREAM DOUGHNUTS CORP, HOOVER, AL, TA
CASTLE CREAM DOUGHNUTS:
4,117,309, PUB. 1-10-2012. INT. CL. 30.

KATARZYNA KARKOWSKA, ASTORIA, NY, DBA STAR-
LIGHT CLASSICS:
4,117,404, PUB. 1-10-2012. INT. CL. 9.

KATHY'S JUST DESSERTS, INC., EAST NORRITON, PA:
4,118,043, PUB. 1-10-2012. INT. CL. 41.
4,118,044, PUB. 1-10-2012. INT. CL. 41.

KATIE NORRIS COLLECTION, LLC, COLLEYVILLE, TX,
AKA FOTOLANTHROPY:
4,118,441, PUB. 1-10-2012. INT. CL. 41.

KATSUKAWA EIICHI, JAPAN:
4,116,816, PUB. 1-10-2012. INT. CL. 25.

KATUN CORPORATION, BLOOMINGTON, MN:
2,967,723, CANC. MULTIPLE CLASS, INT. CLS. 2 AND 9.

KAUSEN, LEE, COEUR D' ALENE, ID AND KAUSEN, JILL,
COEUR D' ALENE, ID:
4,119,515, INT. CL. 28.

KAY GROUP NO. 2 PTY LTD, PORT MELBOURNE,
AUSTRALIA:
4,119,210, INT. CL. 35.

KAYA TAX & BOOKKEEPING SERVICES, INC., IRVINE,
CA:
4,117,516, PUB. 1-10-2012. INT. CL. 35.

KAYABA INDUSTRY CO., LTD., MINATO-KU, TOKYO,
JAPAN, AKA KAYABA KOGYO KABUSHIKI KAISHA:
4,116,611, PUB. 1-10-2012. MULTIPLE CLASS, INT. CLS. 9
AND 37.

KBC AMERICA, INC., BURBANK, CA:
2,971,521, CANC. INT. CL. 25.

KCH SERVICES, INC., FOREST CITY, NC, DBA KCH
ENGINEERED SYSTEMS:
4,117,237, PUB. 1-10-2012. INT. CL. 19.

KCI COMPUTING, INC., TORRANCE, CA, KAY CONSULT-
ING, INC., EL SEGUNDO, CA:
1,671,594. REN. 2-23-12. INT. CL. 9.

KCK INTERNATIONAL, INC., SANTA ANA, CA, DBA
PERMASEAL:
4,117,305, PUB. 1-10-2012. INT. CL. 1.

KEICH, DENNIS, TEMECULA, CA:
4,119,767, INT. CL. 35.

KEILHAUER, SCARBOROUGH, ONTARIO, CANADA:
4,117,047, PUB. 1-10-2012. INT. CL. 20.

KEITER, STEPHENS, HURST, GARY & SHREAVES, P.C.,
GLEN ALLEN, VA:
4,118,472, PUB. 1-10-2012. INT. CL. 35.

KEITH WOODS, RIVERDALE, GA:
4,119,692, INT. CL. 3.

KELLAN, INC, DALLAS, TX, DBA KELLTECH SYSTEMS:
4,117,167, PUB. 1-10-2012. INT. CL. 45.

KELLERMANN, GUIDO, 52062 AACHEN, FED REP GER-
MANY:
2,534,421. REN. 2-23-12. MULTIPLE CLASS, INT. CLS. 12
AND 42.

KELLEY BLUE BOOK CO., INC., IRVINE, CA:
4,117,708, PUB. 1-10-2012. INT. CL. 9.
4,117,709, PUB. 1-10-2012. INT. CL. 9.

KELLOGG COMPANY, BATTLE CREEK, MI:
552,435. REN. 2-21-12. U.S. CL. 46 (INT. CL. 30).

KELLY FOODS CORPORATION, BERLIN, MD:
2,967,455, CANC. INT. CL. 31.

KELLY, KYLE, FAIRLESS HILLS, PA:
4,119,803, INT. CL. 41.

KEMIA, INC., SAN DIEGO, CA:
2,968,135, CANC. INT. CL. 42.
2,968,136, CANC. INT. CL. 42.

KEMP MEEK MANUFACTURING, INC, MINEOLA, TX:
2,946,117, CANC. INT. CL. 9.

KENA INDUSTRIES, INC., CLARKSVILLE, TN:
1,673,336. REN. 2-22-12. INT. CL. 9.

KENDALL ELECTRIC, INC., PORTAGE, MI:
4,117,666, PUB. 1-10-2012. INT. CL. 35.

KENNAMETAL INC., LATROBE, PA:
2,467,781, CANC. INT. CL. 7.

KENNEDY-KLINE, TARA, SHOEMAKERSVILLE, PA:
4,119,121, INT. CL. 41.

KENNETH D. LAUB & COMPANY, INC., NEW YORK, NY:
1,183,208. REN. 2-22-12. INT. CL. 36.

KENSINGTON PUBLISHING CORP., NEW YORK, NY:
2,575,734. REN. 2-21-12. MULTIPLE CLASS, INT. CLS. 16

- AND 41.
 KENYON, SHERRILYN, SPRING HILL, TN:
 4,118,624, PUB. 1-10-2012. INT. CL. 16.
 4,118,625, PUB. 1-10-2012. INT. CL. 16.
 4,118,626, PUB. 1-10-2012. INT. CL. 16.
 4,118,627, PUB. 1-10-2012. INT. CL. 16.
 KERBEY LANE CAFE, INC., AUSTIN, TX:
 4,118,605, PUB. 1-10-2012. INT. CL. 43.
 4,118,606, PUB. 1-10-2012. INT. CL. 43.
 4,118,607, PUB. 1-10-2012. MULTIPLE CLASS, INT. CLS.
 30 AND 40.
 KERTSMAN, ILIA, REDMOND, WA:
 4,117,264, PUB. 1-10-2012. INT. CL. 29.
 KETTERING MEDICAL CENTER, KETTERING, OH:
 2,567,286. REN. 2-21-12. INT. CL. 42.
 2,603,517. REN. 2-21-12. INT. CL. 42.
 KEWPEE, INC., LIMA, OH:
 4,118,588, PUB. 1-10-2012. INT. CL. 30.
 KEY INDUSTRIES, INC., FT. SCOTT, KS:
 1,196,886. REN. 2-22-12. INT. CL. 25.
 KEY SOLUTIONS, INC., BRENTWOOD, TN:
 2,468,579, CANC. INT. CL. 9.
 KEYCORP. CLEVELAND, OH:
 2,968,427, CANC. INT. CL. 36.
 KEYEK-FRANSSSEN, ROBERT D., LAFAYETTE, CO:
 2,468,100, CANC. INT. CL. 12.
 KEYES, DARRYL, PARAMOUNT, CA, DBA AGONY
 CLOTHING COMPANY:
 4,118,225, PUB. 1-10-2012. INT. CL. 25.
 KEYNETICS INC., BOISE, ID:
 4,117,165, PUB. 1-10-2012. INT. CL. 42.
 KEYNOTE SYSTEMS, INC., SAN MATEO, CA:
 2,968,168, CANC. INT. CL. 42.
 KIAWAH ISLAND INN COMPANY, LLC, KIAWAH IS-
 LAND, SC:
 4,117,063, PUB. 1-10-2012. MULTIPLE CLASS, INT. CLS.
 35, 36, 39, 41, 43 AND 44.
 KIDZ ACADEMY, LLC, CHICAGO, IL:
 4,117,654, PUB. 1-10-2012. INT. CL. 43.
 4,117,655, PUB. 1-10-2012. INT. CL. 43.
 KIEFER CONSULTING, INC., FOLSOM, CA:
 4,117,710, PUB. 1-10-2012. INT. CL. 9.
 KIM, DANIEL KYONG C., LOS ANGELES, CA:
 4,118,742, PUB. 1-10-2012. INT. CL. 35.
 KIM, DAVID, COLLEGE POINT, NY:
 4,117,092, PUB. 1-10-2012. INT. CL. 41.
 KIM, HYUNG MIN, REPUBLIC OF KOREA:
 4,116,796, PUB. 1-10-2012. INT. CL. 16.
 KIMBERLY-CLARK WORLDWIDE, INC., NEENAH, WI,
 SCOTT PAPER COMPANY, DELAWARE COUNTY, PA:
 1,739,892. REN. 2-23-12. INT. CL. 21.
 KIMBERLY-CLARK WORLDWIDE, INC., NEENAH, WI:
 4,116,597, PUB. 1-10-2012. INT. CL. 9.
 4,119,682, INT. CL. 21.
 KINETIC JUMP SOFTWARE, LLC, PRIOR LAKE, MN:
 3,563,058, COR. INT. CL. 9.
 KINETIC TECHNOLOGIES, LLC, LEXINGTON, KY:
 4,119,480, INT. CL. 1.
 KINGDOM BUILDER'S PRAYER INSTITUTE, HOUSTON,
 TX:
 4,119,297, INT. CL. 24.
 KINGS CLOTHING INC., RIVER EDGE, NJ:
 4,117,936, PUB. 1-10-2012. INT. CL. 36.
 KINGSDEN'S K-9 COMPANIONS-K-9 SECURITY AND
 DETECTION INT'L. LLC, PERRIS, CA:
 4,118,283, PUB. 1-10-2012. INT. CL. 41.
 KINGWOOD GROUP, INC., THE, KINGWOOD, TX:
 2,467,890, CANC. INT. CL. 9.
 KIOKOM, LLC, SCOTTSDALE, AZ:
 4,116,933, PUB. 1-10-2012. INT. CL. 35.
 KIRK, RYAN, CAMPBELL, CA:
 4,117,287, PUB. 1-10-2012. INT. CL. 41.
 KISS MY FACE, LLC, LOS ANGELES, CA:
 2,968,203, CANC. INT. CL. 3.
 KITA, NATALIE, BEAR, DE, DBA GET SHOT NAKED:
 4,118,434, PUB. 1-10-2012. INT. CL. 41.
 KITOZYME S.A., HERSTAL, BELGIUM:
 4,116,675, PUB. 1-10-2012. MULTIPLE CLASS, INT. CLS.
 1, 5 AND 42.
 KITTY HAWK KITES, INC., NAGS HEAD, NC:
 1,203,093. REN. 2-21-12. MULTIPLE CLASS, INT. CLS. 41
 AND 42.
 KJR SECURITY, LLC, DALLAS, TX:
 4,118,367, PUB. 1-10-2012. MULTIPLE CLASS, INT. CLS.
 40 AND 45.
 KLEEN TEST PRODUCTS CORPORATION, PORT WA-
 SHINGTON, WI:
 1,185,640. REN. 2-22-12. INT. CL. 11.
 KLEIN, ELLIOT, NEW YORK, NY:
 2,968,614, CANC. MULTIPLE CLASS, INT. CLS. 16, 35
 AND 42.
 KLINE, GRAYDON R, BURLEIGH WATERS, QUEENS-
 LAND, AUSTRALIA:
 2,968,470, CANC. INT. CL. 3.
 KNAUF INSULATION GMBH, SHELBYVILLE, IN:
 2,423,614, CANC. INT. CL. 17.
 KNICK ELEKTRONISCHE MESSGERÄTE GMBH & CO.
 KG, FED REP GERMANY:
 4,116,750, PUB. 1-10-2012. INT. CL. 9.
 KNIGHT CHEMICALS, LLC, MILWAUKEE, WI:
 4,117,490, PUB. 1-10-2012. INT. CL. 1.
 KNOWLEDGE ATHLETES, INC., FAIRPORT, NY:
 2,967,440, CANC. INT. CL. 41.
 KNURR GMBH, ARNSTORF, FED REP GERMANY:
 2,561,013. REN. 2-17-12. INT. CL. 9.
 KOHLER FREDA, LLC, PATERSON, NJ, FREDA COR-
 PORATION, PHILADELPHIA, PA:
 1,201,318. REN. 2-23-12. INT. CL. 29.
 KOKORO & MOI OY, HELSINKI, FINLAND:
 4,117,927, PUB. 1-10-2012. INT. CL. 35.
 KOLB CLEANING TECHNOLOGY GMBH, WILlich, FED
 REP GERMANY:
 4,119,498, INT. CL. 1.
 KOMPUGARD CORPORATION, VAN NUYS, CA:
 4,116,588, PUB. 1-10-2012. INT. CL. 35.
 KONAMI DIGITAL ENTERTAINMENT CO., LTD., MINA-
 TO-KU, TOKYO, JAPAN:
 2,967,518, CANC. INT. CL. 28.
 KONCEPT TECHNOLOGIES, INC., MONROVIA, CA:
 4,119,668, INT. CL. 11.
 KOOSHAREM CORPORATION, SANTA BARBARA, CA:
 3,288,183, CANC. INT. CL. 35.
 KOOY, DEBBIE, BRITISH COLUMBIA, CANADA AND
 LAFONTAINE, ALLAN, BRITISH COLUMBIA, CANADA:
 2,967,802, CANC. INT. CL. 28.
 KOPPLA LTD., NEW YORK, NY, DBA KOPPLA NUTRI-
 ENTS AND FSI NUTRITION, OMAHA, NE:
 4,119,293, INT. CL. 5.
 KOREA GINSENG CORP., TAEJON CITY, REPUBLIC OF
 KOREA:
 4,118,880, INT. CL. 32.
 KOWA COMPANY, LTD., AICHI-KEN 460-8625, JAPAN:
 4,116,777, PUB. 1-10-2012. INT. CL. 5.
 KOZEL, JENNIFER, SAN FRANCISCO, CA AND HARRER,
 PAUL A, DUBLIN, CA:
 4,117,830, PUB. 1-10-2012. INT. CL. 35.
 KRASI LIMITED LIABILITY COMPANY, FORT WASHING-
 TON, PA:
 4,118,888, INT. CL. 33.
 KRAZY COUPON LADY LLC, EMMETT, ID:
 4,118,089, PUB. 1-10-2012. INT. CL. 35.
 4,118,094, PUB. 1-10-2012. INT. CL. 35.
 KROGER CO. OF MICHIGAN, THE, NOVI, MI:
 2,623,620. REN. 2-22-12. MULTIPLE CLASS, INT. CLS. 3,
 6, 8, 16, 20 AND 21.
 2,634,257. REN. 2-22-12. INT. CL. 35.
 KRUEGER INTERNATIONAL, INC., GREEN BAY, WI:
 2,564,473. REN. 2-22-12. INT. CL. 20.
 4,119,589, INT. CL. 20.
 KUNICKI PHOTOGRAPHY, INC., SAN DIEGO, CA:
 4,118,008, PUB. 1-10-2012. INT. CL. 41.
 KX SYSTEMS, INC., PALO ALTO, CA:
 2,967,759, CANC. INT. CL. 9.
 L & R PUBLICATIONS, INC., PORT ORANGE, FL:
 2,468,571, CANC. INT. CL. 16.

L. PERRIGO COMPANY, ALLEGAN, MI:
2,967,648, CANC. INT. CL. 5.

L.C. INDUSTRIES, INC., CHICAGO, IL:
2,932,284, CANC. INT. CL. 25.

L-COM, INC., NORTH ANDOVER, MA:
4,117,503, PUB. 1-10-2012. INT. CL. 9.

L'AMBRE GROUPE INTERNATIONAL SP. Z O.O., PO-
LAND:
4,116,782, PUB. 1-10-2012. MULTIPLE CLASS, INT. CLS. 3
AND 35.

L'OREAL USA CREATIVE, INC, NEW YORK, NY, MORE-
HOUSE MANUFACTURING CORPORATION, SAVAN-
NAH, GA:
741,715. REN. 2-22-12. U.S. CL. 51 (INT. CL. 3).

L'OREAL USA CREATIVE, INC., NEW YORK, NY, L'OR-
REAL USA, INC., NEW YORK, NY:
2,663,496. REN. 2-23-12. INT. CL. 3.

L'OREAL USA CREATIVE, INC., NEW YORK, NY:
4,119,122, INT. CL. 3.
4,119,669, INT. CL. 3.

LA FLOR PRODUCTS CO., INC., HAUPPAUGE, NY:
926,512. REN. 2-22-12. U.S. CL. 46 (INT. CL. 30).

LA MER TECHNOLOGY, INC, NEW YORK, NY:
2,524,828. REN. 2-21-12. INT. CL. 3.
2,524,829. REN. 2-21-12. INT. CL. 3.

LA MONEGASQUE, S.A.M., MONACO, MONACO:
1,183,992. REN. 2-17-12. INT. CL. 29.

LABONE, LENEXA, KS:
2,467,422, CANC. MULTIPLE CLASS, INT. CLS. 36 AND
42.

LABORATOIRES SUISSES, S.A., PANAMA CITY, PANAMA:
2,968,070, CANC. INT. CL. 9.

LABRASSEUR WINERY LLC, EAGLE POINT, OR, DBA
LABRASSEUR VINEYARD:
4,118,090, PUB. 1-10-2012. INT. CL. 33.

LACKEY BALLARD PRODUCTIONS, LLC, DURHAM, NC:
4,119,279, MULTIPLE CLASS, INT. CLS. 9 AND 16.

LADUE, HEATHER, ROCHESTER, NY:
4,118,161, PUB. 1-10-2012. MULTIPLE CLASS, INT. CLS.
25 AND 41.

LAJOUS, LUIS, VANCOUVER, WA:
4,118,006, PUB. 1-10-2012. INT. CL. 3.

LAKE ERIE PORTABLE SCREENERS, INC., ERIE, PA:
4,119,288, INT. CL. 7.

LAKESIDE COLLABORATIVE, INC., NEW YORK, NY:
4,118,783, INT. CL. 35.

LAKEWOOD RANCH NUTRITIONAL SCIENCES, LLC,
LAKEWOOD RANCH, FL:
4,118,241, PUB. 1-10-2012. INT. CL. 5.
4,118,242, PUB. 1-10-2012. INT. CL. 5.

LAMBDA OPTICALSYSTEMS CORPORATION, RESTON,
VA:
2,967,804, CANC. INT. CL. 9.

LAMBERT PHARMACAL COMPANY, ST. LOUIS, MO TO
JOHNSON & JOHNSON, NEW BRUNSWICK, NJ:
85,150, AM. U.S. CL. 18.

LAMONS GASKET COMPANY, HOUSTON, TX:
2,540,791. REN. 2-17-12. INT. CL. 6.

LAMONTE WINSTON, OVERLAND PARK, KS:
4,119,074, INT. CL. 35.

LANCE MFG LLC, CHARLOTTE, NC:
2,966,153, CANC. INT. CL. 30.
2,966,154, CANC. INT. CL. 30.

LANCOME PARFUMS ET BEAUTE & CIE, PARIS, FRANCE:
2,967,859, CANC. INT. CL. 3.

LAND'S END ACQUISITION CORPORATION, HOMER, AK:
1,672,200. REN. 2-22-12. INT. CL. 42.

LANDAUER, INC., GLENWOOD, IL:
4,119,329, INT. CL. 42.
4,119,330, INT. CL. 42.

LANDRY'S TRADEMARK, INC., HOUSTON, TX:
2,524,287. REN. 2-21-12. INT. CL. 25.

LANDSCAPE STRUCTURES, INC., DELANO, MN:
4,118,889, INT. CL. 28.

LANE, CORY, NAPA, CA:
4,118,333, PUB. 1-10-2012. INT. CL. 33.

LANGNER COMMUNICATIONS AG, D-22359 HAMBURG,
FED REP GERMANY:
2,967,329, CANC. INT. CL. 9.

LAPP ENGINEERING & CO., SWITZERLAND:
4,116,674, PUB. 1-10-2012. MULTIPLE CLASS, INT. CLS.
8, 9 AND 16.

LARA, JEFFREY PAYNE, NAVASOTA, TX:
4,118,757, INT. CL. 19.

LARRY CALLAHAN, CLAYTON, MO:
4,118,300, PUB. 1-10-2012. INT. CL. 36.

LAS VEGAS EXOTIC CAR RENTALS LLC, LAS VEGAS, NV:
4,117,543, PUB. 1-10-2012. INT. CL. 39.

LASKIN MEDICAL, LLC, GREELEY, CO:
4,117,185, PUB. 1-10-2012. INT. CL. 5.

LATINO COMP, SANTA FE SPRINGS, CA:
4,118,022, PUB. 1-10-2012. MULTIPLE CLASS, INT. CLS.
35 AND 36.

LAURA TWIRLS SUICIDE AWARENESS FOUNDATION,
WONDER LAKE, IL:
4,118,956, INT. CL. 36.

LAURENE A GERSON, GREENWOOD VILLAGE, CO, CO:
4,117,176, PUB. 1-10-2012. INT. CL. 16.

LAVERTY, BEN W. III, BAKERSFIELD, CA:
2,374,576, CANC. INT. CL. 41.

LAWING, ANDREW SCOTT, NEWARK, DE:
4,118,861, INT. CL. 9.

LAWLINE.COM CLE, INC., NEW YORK, NY:
2,562,659. REN. 2-21-12. MULTIPLE CLASS, INT. CLS. 41
AND 42.

LAWRENCE, CARLY, JAMESTOWN, IN:
4,118,805, INT. CL. 25.

LAWSON, ROBERT W., JACKSONVILLE, OR, DBA VINO-
VERITASWINECLUB.COM:
4,117,785, PUB. 1-10-2012. INT. CL. 39.

LAZAR INDUSTRIES, LLC, LOS ANGELES, CA:
2,467,853, CANC. INT. CL. 35.

LC TRADEMARKS, INC., DETROIT, MI:
1,624,182, CANC. INT. CL. 42.

LCS ENTERPRISE LLC, LAS VEGAS, NV:
4,118,505, PUB. 1-10-2012. INT. CL. 35.

LE CERCLE DES VIGNERONS DE PROVENCE, 83170
BRIGNOLES, FRANCE:
923,583. REN. 2-21-12. U.S. CL. 47 (INT. CL. 33).

LEACHCO, INC., ADA, OK:
4,119,578, MULTIPLE CLASS, INT. CLS. 10 AND 20.

LEADING EDGE ROBOTICS INC., FREELTON, ONTARIO,
CANADA:
2,467,337, CANC. INT. CL. 9.

LEANIN' TREE INC., BOULDER, CO:
2,968,565, CANC. INT. CL. 16.

LEAP OF FAITH TECHNOLOGIES, INC., CRYSTAL LAKE,
IL:
2,468,291, CANC. INT. CL. 9.

LEARNING STAR PUBLICATIONS, BEAVERCREEK, OH:
4,118,102, PUB. 1-10-2012. INT. CL. 16.

LEARNING-FOCUSED SOLUTIONS, INC., BOONE, NC:
4,117,660, PUB. 1-10-2012. INT. CL. 41.

LEASEFAX, LLC, TROY, MI:
4,117,542, PUB. 1-10-2012. INT. CL. 39.
4,117,564, PUB. 1-10-2012. INT. CL. 39.

LEBLON FOODS, INC., CANASTOTA, NY:
4,119,809, INT. CL. 32.

LECO CORPORATION, ST. JOSEPH, MI:
4,119,261, INT. CL. 9.

LECOMPTE, HAP, ROSSMOOR, CA:
4,119,532, MULTIPLE CLASS, INT. CLS. 35 AND 42.

LEE COUNTY BOARD OF COUNTY COMMISSIONERS,
FORT MYERS, FL:
4,119,255, INT. CL. 1.

LEE, SEAN SANGSOO, LOS ANGELES, CA:
4,116,552, PUB. 5-27-2008. INT. CL. 5.

LEFT COAST MEDIA, INC., PISMO BEACH, CA:
4,118,320, PUB. 1-10-2012. INT. CL. 41.

LEGACIE ACCESSORIES LLC, NEW YORK, NY:
4,119,332, INT. CL. 9.

LEGENE BIOSCIENCES CORP., SAN DIEGO, CA:
4,118,541, PUB. 1-10-2012. INT. CL. 1.
4,118,557, PUB. 1-10-2012. INT. CL. 1.

- LEGG MASON & CO., LLC, BALTIMORE, MD:
2,556,498. REN. 2-21-12. INT. CL. 36.
- LEHIGH VALLEY CHIROPRACTIC, PC, BETHLEHEM, PA:
4,118,303. PUB. 1-10-2012. INT. CL. 44.
- LEIGHT, JR., HOWARD S., SAN DIEGO, CA:
4,116,577. PUB. 1-10-2012. INT. CL. 33.
- LEITNER, NATHAN C. GARDENA, CA:
4,117,060. PUB. 1-10-2012. INT. CL. 25.
- LENOX ADVISORS, INC., NEW YORK, NY:
4,117,333. PUB. 1-10-2012. MULTIPLE CLASS, INT. CLS.
35, 36 AND 41.
- LENOX CORPORATION, BRISTOL, PA:
1,160,674. CANC. MULTIPLE CLASS, INT. CLS. 8, 20
AND 21.
- LENTIART, LLC., SHELBYVILLE, TN:
4,118,436. PUB. 1-10-2012. MULTIPLE CLASS, INT. CLS.
16 AND 41.
- LEONA INTERNACIONAL, S.A., ZONA LIBRE DE COLON,
PANAMA:
2,968,209. CANC. INT. CL. 25.
- LEONARD, MARIO DEMONT, ADAMSVILLE, AL AND
SMITH, EARNEST, BIRMINGHAM, AL AND MYERS,
STEVEN, BIRMINGHAM, AL:
2,968,389. CANC. INT. CL. 41.
- LES ACIERS ROBOND INC., MAGOG, QUEBEC, CANADA:
4,117,563. PUB. 10-4-2011. INT. CL. 12.
- LES ASSAISSEMENTS BRIARDS, NANTEUIL-LES-
MEAUX, FRANCE:
1,187,012. REN. 2-22-12. INT. CL. 30.
- LET IT MOVE, INC., SHAWNEE, KS:
4,118,502. PUB. 1-10-2012. INT. CL. 41.
- LEVINGER COMPANY, DELRAY BEACH, FL:
2,468,005. CANC. INT. CL. 16.
2,468,007. CANC. INT. CL. 16.
2,468,008. CANC. INT. CL. 16.
- LEVERETT, DANELLE, ATLANTA, GA AND BROWN,
SUSAN, ATLANTA, GA:
4,118,883. INT. CL. 9.
- LEVI INNOVATIONS, INC., FLETCHER, NC:
2,560,161. REN. 2-23-12. INT. CL. 6.
- LEVI STRAUSS & CO., SAN FRANCISCO, CA:
2,968,635. CANC. INT. CL. 25.
- LEVINE, MICHAEL B, BOYNTON BEACH, FL, DBA REN-
TAMENSCH:
4,117,632. PUB. 1-10-2012. INT. CL. 37.
- LEWIS AND ROCA LLP, PHOENIX, AZ:
2,611,953. REN. 2-22-12. INT. CL. 42.
- LEWIS, MARK, LOS ANGELES, CA:
2,968,575. CANC. INT. CL. 25.
- LFP IP, LLC, BEVERLY HILLS, CA:
2,582,229. REN. 2-22-12. INT. CL. 41.
- LG ELECTRONICS INC., SEOUL, REPUBLIC OF KOREA:
4,116,650. PUB. 1-10-2012. MULTIPLE CLASS, INT. CLS.
7, 9, 10, 11, 35 AND 38.
4,116,651. PUB. 1-10-2012. MULTIPLE CLASS, INT. CLS.
7, 9, 10, 11, 35 AND 38.
4,116,652. PUB. 1-10-2012. MULTIPLE CLASS, INT. CLS.
7, 9, 10, 11, 35 AND 38.
4,116,653. PUB. 1-10-2012. MULTIPLE CLASS, INT. CLS.
7, 9, 10, 11, 35 AND 38.
4,116,654. PUB. 1-10-2012. INT. CL. 9.
- LHK PARTNERS, INC., NEWTOWN SQUARE, PA:
4,117,077. PUB. 1-10-2012. INT. CL. 35.
- LI, VICTOR F., SAN DIEGO, CA:
2,468,459. CANC. INT. CL. 16.
- LIANG CHI INDUSTRY CO., LTD., TAOYUAN HSIEN,
TAIWAN:
4,117,737. PUB. 1-10-2012. INT. CL. 7.
- LIBERTY MUTUAL INSURANCE COMPANY, BOSTON,
MA:
4,118,274. PUB. 1-10-2012. INT. CL. 36.
- LIBMAN COMPANY, THE, ARCOLA, IL:
1,673,014. REN. 2-22-12. INT. CL. 21.
- LICENSE BRANDING, LLC, SAN ANTONIO, TX:
4,119,362. INT. CL. 16.
- LICHTBLICK AG, FED REP GERMANY:
4,116,761. PUB. 1-10-2012. MULTIPLE CLASS, INT. CLS.
7, 9, 11, 12, 35, 36, 37, 38, 39, 40 AND 42.
- LIEBERTZ, ROBERT, LIVONIA, MI:
4,117,415. PUB. 1-10-2012. INT. CL. 35.
- LIEN INICIATIVES EMPRESARIALS I NEGOCIS, S.L.,
SPAIN:
4,116,756. PUB. 1-10-2012. INT. CL. 7.
- LIFE CORPORATION, MILWAUKEE, WI:
2,644,874. REN. 2-22-12. INT. CL. 10.
- LIFESTYLE BRANDS CORPORATION, ENGLEWOOD, CO:
4,118,995. INT. CL. 28.
4,118,996. INT. CL. 28.
4,118,997. INT. CL. 28.
4,118,998. INT. CL. 28.
4,119,013. INT. CL. 28.
- LIFEWAYS NORTH AMERICA, INCORPORATED, NOR-
MAN, OK:
4,117,282. PUB. 1-10-2012. INT. CL. 41.
- LIGHTCRAFT TECHNOLOGIES, INC., BENNINGTON, VT:
2,557,995. REN. 2-22-12. INT. CL. 42.
- LIGHTING CONCEPTS AND SOLUTIONS, INC., CORAL
SPRINGS, FL:
4,116,904. PUB. 1-10-2012. MULTIPLE CLASS, INT. CLS. 9
AND 11.
- LIGHTWEDGE, INC., NEWTON, MA:
4,119,035. MULTIPLE CLASS, INT. CLS. 9 AND 11.
- LILYGILD LTD., BROOKLYN, NY:
2,968,404. CANC. INT. CL. 28.
- LINCOLN APPRAISAL & SETTLEMENT SERVICES, LLC,
PROVIDENCE, RI:
4,117,606. PUB. 1-10-2012. MULTIPLE CLASS, INT. CLS.
36 AND 45.
- LINDER, SHERRY, PORTLAND, OR, DBA SEAMS TO FIT:
4,118,542. PUB. 1-10-2012. INT. CL. 35.
- LINICK, ANDREW, MIDDLE ISLAND, NY:
4,117,188. PUB. 1-10-2012. INT. CL. 41.
4,117,197. PUB. 1-10-2012. INT. CL. 41.
- LINK SNACKS, INC., MINONG, WI:
4,119,593. INT. CL. 29.
- LIONEL TRADEMARK LLC, CHESTERFIELD, MI:
4,116,628. PUB. 1-10-2012. INT. CL. 28.
- LIPSTICKN'LAUNDRY LLC, ST. LOUIS, MO:
4,117,506. PUB. 1-10-2012. INT. CL. 41.
- LIQUID BREAKER, LLC, CARLSBAD, CA:
4,119,748. INT. CL. 11.
- LIQUID CODE DESIGN, L.L.C., BELLEVUE, NE:
2,968,606. CANC. INT. CL. 42.
- LIQUID HEALTH LABS, INC., DEERFIELD, NH:
4,116,960. PUB. 10-4-2011. INT. CL. 5.
- LIQUIDPLANNER, INC., BELLEVUE, WA:
4,119,451. MULTIPLE CLASS, INT. CLS. 39 AND 42.
- LITEYE SYSTEMS INC., CENTENNIAL, CO:
4,117,741. PUB. 1-10-2012. INT. CL. 9.
- LITTLE AMERICAN BUSINESSES, INC., COSTA MESA, CA:
4,117,468. PUB. 12-6-2011. MULTIPLE CLASS, INT. CLS.
25, 35 AND 36.
- LITTLEFIELD, DONALD BRUCE, FOLSOM, CA:
2,527,584. REN. 2-22-12. INT. CL. 35.
- LITTON, JERRY L., PELAHATCHIE, MS:
2,468,521. CANC. INT. CL. 42.
- LIVE AWAKE LLC, SAN FRANCISCO, CA:
4,117,158. PUB. 1-10-2012. INT. CL. 43.
- LIVE GREAT FOODS, LLC, MADISON, WI:
4,118,917. MULTIPLE CLASS, INT. CLS. 29 AND 32.
- LIVING BASEBALL CARD, LLC, MUSKEGON, MI:
4,119,413. INT. CL. 9.
- LIVING DIRECT, INC., AUSTIN, TX:
4,117,651. PUB. 1-10-2012. MULTIPLE CLASS, INT. CLS. 7
AND 11.
- LIVON LABORATORIES, INC., HENDERSON, NV:
4,119,176. INT. CL. 5.
4,119,177. INT. CL. 5.
- LIZ CLAIBORNE, INC., NEW YORK, NY:
2,968,049. CANC. MULTIPLE CLASS, INT. CLS. 19 AND
27.
- LMA FOOD CONCEPTS, S.C., GARZA GARCIA N.L.,
MEXICO:
4,119,305. INT. CL. 43.
- LML PAYMENT SYSTEMS CORP., DALLAS, TX:
2,968,334. CANC. INT. CL. 36.

LMS MEDICAL SYSTEMS (CANADA) LTD., MONTREAL, CANADA:
2,466,849, CANC. INT. CL. 9.

LMT GMBH & CO. KG, FED REP GERMANY:
4,116,784, PUB. 1-10-2012. INT. CL. 7.

LO VI POR TV, LLC, HIALEAH, FL:
4,117,425, PUB. 1-10-2012. INT. CL. 3.

LOBAN, JOSEPH PETER, EVANSTON, IL:
4,118,834, INT. CL. 15.

LOCH LOMOND GOLF CLUB, SCOTTSDALE, AZ:
2,467,349, CANC. MULTIPLE CLASS, INT. CLS. 25 AND 28.

LOCKHEED MARTIN CORPORATION, BETHESDA, MD:
2,528,843. REN. 2-17-12. INT. CL. 13.
2,539,263. REN. 2-17-12. INT. CL. 28.

LOEW-CORNELL, LLC, ERLANGER, KY:
4,118,298, PUB. 1-10-2012. INT. CL. 16.

LOGAN CLUTCH CORPORATION, CLEVELAND, OH:
2,572,768. REN. 2-17-12. INT. CL. 7.

LOGLOGIC, INC., SAN JOSE, CA:
4,118,168, PUB. 1-10-2012. INT. CL. 9.

LOINT'S OF HOLLAND B.V., NETHERLANDS:
4,116,721, PUB. 1-10-2012. INT. CL. 25.

LOKO, INDUSTRIES, SAN RAMON, CA:
4,119,084, INT. CL. 9.

LOMBARD ODIER DARIER HENTSCH & CIE., 1202 GENEVA, SWITZERLAND:
2,968,133, CANC. INT. CL. 36.

LOMBARDI, TOM, SCOTTSDALE, AZ:
2,968,561, CANC. INT. CL. 25.

LONDON BROADCASTING COMPANY, INC., ADDISON, TX:
4,117,027, PUB. 1-10-2012. INT. CL. 38.

LONG BEACH BOULEVARD BURGERS, INC., SANTA FE SPRINGS, CA:
4,117,940, PUB. 1-10-2012. INT. CL. 43.

LONG'S AMUSEMENT COMPANY, INC., NEWPORT NEWS, VA:
2,967,595, CANC. INT. CL. 28.

LONGWOOD COUNTRY GARDEN CENTERS, INC., WINSTON-SALEM, NC:
1,746,187. REN. 2-21-12. INT. CL. 42.

LONZA INC., ALLENDALE, NJ, GLYCO INC., GREENWICH, CT:
1,187,308. REN. 2-17-12. INT. CL. 4.

LONZA WALKERSVILLE, INC., WALKERSVILLE, MD:
4,117,511, PUB. 1-10-2012. INT. CL. 9.

LORAIN PUBLIC LIBRARY SYSTEM, LORAIN, OH:
4,117,585, PUB. 1-10-2012. INT. CL. 41.

LORILLARD LICENSING COMPANY LLC, GREENSBORO, NC, LOEW'S THEATRES, INC., NEW YORK, NY, AKA LORILLARD DIVISION:
1,191,816. REN. 2-21-12. INT. CL. 34.

LORIS AZZARO B.V., APELDOORN, NETHERLANDS:
2,968,211, CANC. INT. CL. 3.

LORNAMEAD GROUP LIMITED, CAMBERLEY, UNITED KINGDOM:
2,967,686, CANC. INT. CL. 3.

LOTFY, HUSSEIN, CAIRO, EGYPT, LOTFY, MOHAMED HUSSEIN, CAIRO, 11111, EGYPT:
929,941. REN. 2-21-12. U.S. CL. 22 (INT. CL. 28).

LOUISIANA ENERGY SERVICES, LLC, WILMINGTON, NEW CASTLE, DE:
4,119,053, MULTIPLE CLASS, INT. CLS. 35, 39 AND 40.

LOUISIANA ONLINE, INC., BATON ROUGE, LA:
2,534,977. REN. 2-22-12. INT. CL. 35.

LOUISVILLE BEDDING COMPANY, LOUISVILLE, KY:
2,968,617, CANC. INT. CL. 20.

LOUISVILLE'S EPICUREAN MARKETS, LLC, LOUISVILLE, KY:
4,119,131, INT. CL. 30.

LOUNIBOS, LOUNIBOS & TINNEY, PETALUMA, CA:
2,468,271, CANC. INT. CL. 9.

LOVEFEAST LIFE, LLC, PRIOR LAKE, MN:
4,118,539, PUB. 1-10-2012. INT. CL. 41.
4,118,540, PUB. 1-10-2012. INT. CL. 41.

LOVETT-WOODSUM, CAMERON P, BOSTON, MA:
4,117,107, PUB. 1-10-2012. INT. CL. 25.

LOWENSTEIN, KENNETH, GLEN ALLEN, VA:
2,968,314, CANC. INT. CL. 25.

LOWERCASE, INC., CHICAGO, IL:
4,118,733, PUB. 1-10-2012. INT. CL. 42.

LOYOLA UNIVERSITY HEALTH SYSTEM, MAYWOOD, IL:
2,467,870, CANC. INT. CL. 42.

LQ MECHATRONIK-SYSTEME GMBH, 74354 BESIGHEIM, FED REP GERMANY:
4,116,688, PUB. 1-10-2012. MULTIPLE CLASS, INT. CLS. 7, 9, 17, 37, 38 AND 42.

LRN CORPORATION, LOS ANGELES, CA:
2,539,781. REN. 2-22-12. INT. CL. 42.

LUA TECHNOLOGIES, LLC, WILMINGTON, DE:
4,119,430, INT. CL. 42.

LUCCHESI, INC., EL PASO, TX:
555,056. REN. 2-19-12. U.S. CL. 39 (INT. CL. 25).

LUCKY CRAFT CO., LTD., OYABE-SHI, TOYAMA, JAPAN:
4,119,435, INT. CL. 28.
4,119,436, INT. CL. 28.

LUFTHANSA TECHNIK AG, 22335 HAMBURG, FED REP GERMANY:
3,038,687, CANC. MULTIPLE CLASS, INT. CLS. 12 AND 40.

LUIS LOPEZ, SAN DIEGO, CA:
4,117,921, PUB. 1-10-2012. INT. CL. 20.

LUM KA NAAD THAI CUISINE RESTAURANTS, NORTH-RIDGE, CA, DBA LUM KA NAAD THAI CUISINE RESTAURANTS:
4,117,584, PUB. 1-10-2012. INT. CL. 43.

LUMMUS TECHNOLOGY INC., BLOOMFIELD, NJ:
4,118,799, INT. CL. 1.

LUNDBERG SURVEY INCORPORATED, CAMARILLO, CA, LUNDBERG SURVEY INCORPORATED, NORTH HOLLYWOOD, CA:
1,204,472. REN. 2-21-12. INT. CL. 16.

LUNKER'S, INC., EDWARDSBURG, MI, DANNY R. STRIZ AND FRANCES C. STRIZ, EDWARDSBURG, MI, DBA LUNKER'S:
1,669,837. REN. 2-21-12. INT. CL. 42.

LUXE-T, INC., CHANTILLY, VA:
2,967,948, CANC. INT. CL. 25.

LUXXE, INC., BOCA RATON, FL:
4,119,197, INT. CL. 25.

LYDIAN MARKETING GROUP, LLC, INCLINE VILLAGE, NV:
4,118,744, PUB. 1-10-2012. MULTIPLE CLASS, INT. CLS. 3 AND 32.

LYF PRODUCTIONS LLC, SARASOTA, FL:
4,117,172, PUB. 1-10-2012. INT. CL. 18.

LYMPHOMA RESEARCH FOUNDATION, NEW YORK, NY:
4,118,226, PUB. 1-10-2012. MULTIPLE CLASS, INT. CLS. 25, 36 AND 41.

LYNCH STANFORD R, HYDE PARK, MA:
4,119,265, INT. CL. 25.

LYNN LOCKLEAR DDS AND ASSOCIATES, PC, WASHINGTON, DC:
2,966,182, CANC. INT. CL. 44.

L1 TECHNOLOGIES, INC., SAN DIEGO, CA:
4,119,469, INT. CL. 42.

M & B RESTAURANTS, L.C., SCOTTSDALE, AZ:
2,967,447, CANC. INT. CL. 42.

M PROJECTS ASSETS S.A., PANAMA, PANAMA:
2,537,308. REN. 2-22-12. MULTIPLE CLASS, INT. CLS. 9 AND 41.

M. SHANKEN COMMUNICATIONS, INC., NEW YORK, NY:
4,116,616, PUB. 1-10-2012. MULTIPLE CLASS, INT. CLS. 16, 41 AND 43.

M. Z. BERGER & CO., INC., LONG ISLAND CITY, NY:
4,119,715, INT. CL. 14.

M.MARSIAJ & C. S.R.L., I-10123 TORINO, ITALY:
2,965,505, CANC. MULTIPLE CLASS, INT. CLS. 9, 12, 14, 25 AND 28.

M.Z. BERGER & CO., INC., LONG ISLAND CITY, NY:
727,232. REN. 2-22-12. U.S. CL. 27 (INT. CL. 14).

M&M GIFT SHOWS, LLC, TOLEDO, OH:
4,119,856, INT. CL. 35.

M&M SYSTEMS, INC., ORMOND BEACH, FL:
2,968,535, CANC. INT. CL. 9.

- MA, FRANCE:
4,116,783, PUB. 1-10-2012. INT. CL. 25.
- MACE TRADEMARK II, INC., BENNINGTON, VT:
4,119,078, INT. CL. 9.
4,119,079, INT. CL. 9.
- MACERICH VALLEY VIEW LIMITED PARTNERSHIP,
SANTA MONICA, CA:
2,965,425, CANC. MULTIPLE CLASS, INT. CLS. 35, 36
AND 37.
- MACHINE VISION CONSULTING, INC., WESTBOROUGH,
MA:
4,117,166, PUB. 1-10-2012. MULTIPLE CLASS, INT. CLS. 9
AND 42.
- MACKWORTH INTERNATIONAL LTD., ROAD TOWN,
TORTOLA, BR. VIRGIN ISLANDS:
4,117,324, PUB. 1-10-2012. MULTIPLE CLASS, INT. CLS.
38, 41 AND 45.
- MACRESO, INC., COOKEVILLE, TN:
2,967,881, CANC. INT. CL. 40.
- MACROVISION CORPORATION, SANTA CLARA, CA:
2,967,803, CANC. INT. CL. 9.
- MACX, INC., BRISTOL, RI:
2,967,639, CANC. INT. CL. 6.
- MACY'S MERCHANDISING GROUP, INC., NEW YORK,
NY:
2,966,268, CANC. MULTIPLE CLASS, INT. CLS. 21, 24
AND 27.
- MAD CATZ, INC., SAN DIEGO, CA:
2,545,082, REN. 2-21-12. INT. CL. 9.
- MAD DOG MULTIMEDIA, INC., SAN DIEGO, CA:
2,968,814, CANC. INT. CL. 9.
- MAELZEREI MEUSSDOERFFER GMBH & CO. KG, KULM-
BACH, FED REP GERMANY:
2,968,803, CANC. INT. CL. 31.
- MAESTRO LEARNING, INC., CAMBRIDGE, MA:
4,119,504, MULTIPLE CLASS, INT. CLS. 9 AND 42.
- MAGIC CASTLES, INC., HOLLYWOOD, CA:
2,554,845, REN. 2-22-12. MULTIPLE CLASS, INT. CLS. 25,
41 AND 42.
- MAGPUL INDUSTRIES CORP., BOULDER, CO:
4,118,724, PUB. 1-10-2012. INT. CL. 13.
- MAHARAM FABRIC CORPORATION, HAUPPAUGE, NY:
2,967,370, CANC. INT. CL. 24.
- MAHR FEDERAL INC., PROVIDENCE, RI:
2,665,464, REN. 2-22-12. INT. CL. 9.
- MAIDS INTERNATIONAL, INC., THE, OMAHA, NE:
1,184,135, REN. 2-21-12. INT. CL. 37.
- MAINA ORGANI DI TRASMISSIONE S.P.A., ITALY:
4,116,753, PUB. 1-10-2012. INT. CL. 7.
- MAKISELIFEUP LABORATORY CO., LTD., OKINAWA,
JAPAN:
4,117,843, PUB. 1-10-2012. INT. CL. 5.
- MALKA, DANIELLE, MORICHES, NY:
4,116,566, PUB. 1-10-2012. MULTIPLE CLASS, INT. CLS.
3, 8 AND 21.
- MALVERN INSTRUMENTS LIMITED, UNITED KING-
DOM:
4,116,719, PUB. 1-10-2012. INT. CL. 9.
- MALVERN MINERALS COMPANY, HOT SPRINGS, AR:
1,191,462, REN. 2-22-12. INT. CL. 1.
- MAN GROUP PLC, LONDON, UNITED KINGDOM:
3,147,608, CANC. MULTIPLE CLASS, INT. CLS. 16 AND
35.
- MAN-D-TEC, INC., SCOTTSDALE, AZ:
4,119,842, INT. CL. 11.
- MANASEK, FRANCIS, J., NORWICH, VT:
2,968,199, CANC. INT. CL. 9.
- MANDALAY REAL ESTATE LIMITED, NEUCHATEL,
SWITZERLAND:
4,118,881, INT. CL. 35.
- MANILA S.R.L., ITALY:
4,116,768, PUB. 1-10-2012. MULTIPLE CLASS, INT. CLS.
3, 9, 14 AND 18.
- MANKIND SYDNEY PTY LTD, SYDNEY, AUSTRALIA:
4,117,204, PUB. 1-10-2012. INT. CL. 3.
- MANNING, TERRY, ECRU, MS AND BLACKWELL,
CHRISTOPHER, ECRU, MS:
4,117,459, PUB. 1-10-2012. INT. CL. 9.
- MANSION PRODUCTIONS, LLC, CARSON CITY, NV, DBA
MANSION PRODUCTIONS, INC.:
4,116,605, PUB. 1-10-2012. MULTIPLE CLASS, INT. CLS.
9, 35 AND 42.
- MANSUETO VENTURES LLC, CHICAGO, IL:
2,967,402, CANC. INT. CL. 42.
- MANTILLA DIAZ, MARCO, MIAMI, FL:
4,118,446, PUB. 1-10-2012. INT. CL. 25.
- MANTROSE-HAEUSER CO., INC., ATTLEBORO, CT, MILL-
MASTER ONYX GROUP, INC., WESTPORT, CT, DBA
MANTROSE-HAEUSER CO.:
1,666,331, REN. 2-23-12. INT. CL. 1.
- MANUFACTURAS ECONOMICAS S. EN C.S., CALI VALLE,
COLOMBIA:
4,117,757, PUB. 1-10-2012. INT. CL. 25.
- MANULELE CANE COMPANY, LLC, KUNIA, HI:
4,119,381, INT. CL. 30.
- MANZEN, LLC, LAS VEGAS, NV:
4,117,190, PUB. 1-10-2012. INT. CL. 35.
4,117,191, PUB. 1-10-2012. INT. CL. 25.
- MAQUET S.A., ARDON, FRANCE:
2,966,468, CANC. INT. CL. 10.
- MAR-JAC POULTRY, INC., GAINESVILLE, GA, MAR-JAC
PROCESSING, INC., GAINESVILLE, GA:
1,673,897, REN. 2-22-12. INT. CL. 29.
- MARA'S SYSTEMS LLC, DENVER, NJ:
4,118,568, PUB. 1-10-2012. INT. CL. 43.
- MARC G. TIMM, ALEXANDRIA, VA:
4,118,066, PUB. 1-10-2012. INT. CL. 41.
- MARCHESI ANTINORI S.R.L., ITALY:
4,116,799, PUB. 1-10-2012. INT. CL. 33.
- MARDALVI INTERNATIONAL USA, INC., MIAMI, FL:
4,118,589, PUB. 1-10-2012. INT. CL. 30.
- MARDEL, INC., OKLAHOMA CITY, OK:
2,522,074, REN. 2-21-12. INT. CL. 35.
- MARDENKRO HOLDING B.V., NETHERLANDS:
4,116,873, PUB. 1-10-2012. INT. CL. 2.
- MARGARETE STEIFF GMBH, 89537 GIENGEN, FED REP
GERMANY:
2,467,419, CANC. INT. CL. 25.
- MARIEN CAPITAL, S.L., SPAIN:
4,116,806, PUB. 1-10-2012. MULTIPLE CLASS, INT. CLS.
39 AND 43.
- MARIMEKKO OYJ, HELSINKI, FINLAND:
4,116,725, PUB. 1-10-2012. MULTIPLE CLASS, INT. CLS.
16, 18, 21, 24 AND 25.
- 4,116,730, PUB. 1-10-2012. MULTIPLE CLASS, INT. CLS.
16, 18, 21, 24 AND 25.
- MARK ANTHONY INTERNATIONAL SRL, ST. MICHAEL,
BARBADOS:
2,967,547, CANC. MULTIPLE CLASS, INT. CLS. 18 AND
25.
- 4,119,651, MULTIPLE CLASS, INT. CLS. 32 AND 33.
- MARK GREEN, ASHLAND CITY, TN:
4,116,576, PUB. 1-10-2012. MULTIPLE CLASS, INT. CLS.
35 AND 44.
- MARK JONATHAN DAVIS, PASADENA, CA:
4,119,189, MULTIPLE CLASS, INT. CLS. 9 AND 41.
- MARK TUCKER, ANN ARBOR, MI:
4,118,569, PUB. 1-10-2012. INT. CL. 41.
- MARKET AMERICA, INC., GREENSBORO, NC:
4,117,552, PUB. 1-10-2012. INT. CL. 35.
- MARKETING STRATEGY ALLIANCE LLC, ISLAND LAKE,
IL:
2,967,567, CANC. INT. CL. 7.
- MARKWARDT, TERRY, L, AUSTIN, TX:
4,118,375, PUB. 1-10-2012. INT. CL. 20.
- MARLA MARTENSON, LOS ANGELES, CA:
4,117,973, PUB. 1-10-2012. MULTIPLE CLASS, INT. CLS.
41 AND 45.
- 4,117,975, PUB. 1-10-2012. MULTIPLE CLASS, INT. CLS.
41 AND 45.
- MARQUEZE, RHANDY, SÃO PAULO, BRAZIL:
4,119,606, INT. CL. 41.
- MARRICK PROPERTIES, INC., DUNKIRK, MD:
4,118,492, PUB. 1-10-2012. INT. CL. 37.

MARS, INCORPORATED, MCLEAN, VA:
2,542,420, REN. 2-23-12. INT. CL. 9.
2,967,388, CANC. INT. CL. 16.
2,967,542, CANC. INT. CL. 28.
2,967,543, CANC. INT. CL. 28.

MARSHALL, JAMES F., GERMANTOWN, WI:
4,117,147, PUB. 1-10-2012. MULTIPLE CLASS, INT. CLS.
16 AND 36.

MARSHALL, LINDA ELOVITZ, SELKIRK, NY:
2,967,461, CANC. INT. CL. 28.

MARSHALL'S INDUSTRIAL HARDWARE, INC., SAN DIEGO, CA:
4,118,287, PUB. 1-10-2012. INT. CL. 35.

MARTENS, RUSSELL A., WELLINGTON, FL AND MARTENS, PAMELA K., WESTMORELAND, NH:
4,119,439, INT. CL. 36.

MARTIN AND OSA JOHNSON SAFARI MUSEUM, INC., THE, CHANUTE, KS:
1,690,553, REN. 2-17-12. INT. CL. 41.

MARTIN FLUID POWER COMPANY, TROY, MI:
4,117,673, PUB. 1-10-2012. INT. CL. 17.

MARTIN FRANCHISES INC., CINCINNATI, OH:
1,202,943, REN. 2-22-12. INT. CL. 35.

MARTIN FRANCHISES INC., LOVELAND, OH:
1,202,954, REN. 2-21-12. INT. CL. 35.

MARTIN, TIMOTHY, ORANGE, CA:
4,117,467, PUB. 1-10-2012. MULTIPLE CLASS, INT. CLS.
9, 25 AND 41.

MARTINGALE ASSET MANAGEMENT, LP, BOSTON, MA:
2,968,531, CANC. INT. CL. 36.

MARVEL CHARACTERS, INC., MANHATTAN BEACH, CA:
1,178,554, REN. 2-22-12. INT. CL. 41.
2,539,936, REN. 2-21-12. INT. CL. 41.
4,118,573, PUB. 1-10-2012. INT. CL. 41.
4,118,574, PUB. 1-10-2012. INT. CL. 9.
4,118,712, PUB. 1-10-2012. INT. CL. 16.
4,118,872, INT. CL. 16.

MARY E. B. DAVIS, LOS ANGELES, CA, DBA COLON ROLLIN':
4,117,722, PUB. 1-10-2012. INT. CL. 44.

MARY KAY INC., ADDISON, TX:
2,542,184, REN. 2-23-12. MULTIPLE CLASS, INT. CLS. 3,
9, 16 AND 21.

MASARTI INTERNATIONAL ENTERPRISE, LLC, HIALEAH, FL:
4,118,027, PUB. 1-10-2012. INT. CL. 28.
4,118,029, PUB. 1-10-2012. INT. CL. 28.
4,118,030, PUB. 1-10-2012. INT. CL. 28.

MASCIULLI, LEO, PRINCETON, NJ:
2,968,388, CANC. INT. CL. 41.

MASCO FRAMING CORP., CHANDLER, AZ:
4,118,839, INT. CL. 37.

MASQUE PUBLISHING, INC., LONE TREE, CO:
4,117,398, PUB. 1-10-2012. INT. CL. 9.

MASSACHUSETTS STATE COLLEGIATE ATHLETIC CONFERENCE, WESTFIELD, MA:
4,117,094, PUB. 1-10-2012. U.S. CL. 200.

MESSAGE ADVANTAGE, INC., SHERWOOD, AR:
4,117,528, PUB. 10-4-2011. INT. CL. 44.

MASSENGILL, MARTHA JO, TERRELL, TX:
4,119,554, INT. CL. 28.

MASTER CRAFT PRODUCTS CORP., DANA POINT, CA:
4,117,577, PUB. 1-10-2012. INT. CL. 8.

MASTER LOCK COMPANY LLC, OAK CREEK, WI:
4,117,020, PUB. 1-10-2012. INT. CL. 22.

MASTER METER, INC., LONGVIEW, TX:
2,546,675, REN. 2-21-12. INT. CL. 9.

MASTER MY MARKETING, LLC, CLINTON, MS:
4,117,836, PUB. 1-10-2012. INT. CL. 42.

MASTERS BASKETBALL USA, JACKSONVILLE, FL:
4,118,270, PUB. 1-10-2012. INT. CL. 35.

MASTRONARDI PRODUCE LTD., SANTA BARBARA, CA:
4,116,967, PUB. 1-10-2012. INT. CL. 31.

MATERIAL HANDLING INDUSTRY, CHARLOTTE, NC:
2,476,615, CANC. INT. CL. 42.

MATJEK ENTERPRISES, INC., DOWNERS GROVE, IL:
4,119,113, MULTIPLE CLASS, INT. CLS. 35 AND 40.

MATS, INCORPORATED, STOUGHTON, MA:
2,967,810, CANC. MULTIPLE CLASS, INT. CLS. 19 AND
27.

MATSON ALARM COMPANY, INC., FRESNO, CA:
4,117,148, PUB. 1-10-2012. INT. CL. 9.

MATSON AUTOMOTIVE INDUSTRIES PTY LTD, STMARYS NSW 2760, AUSTRALIA:
1,673,349, REN. 2-21-12. INT. CL. 9.

MATSON, SETH, HUNTINGTON BEACH, CA AND TUFO, JONATHAN, HUNTINGTON BEACH, CA:
2,968,608, CANC. INT. CL. 9.

MATSUKI TEI, TOKYO 152-0022, JAPAN:
4,116,733, PUB. 1-10-2012. INT. CL. 3.

MATSUM, INC., LOS ALAMITOS, CA:
4,119,843, INT. CL. 10.

MATTEL, INC., EL SEGUNDO, CA:
1,221,918, REN. 2-21-12. INT. CL. 28.
2,967,347, CANC. MULTIPLE CLASS, INT. CLS. 3, 9, 16,
20, 21, 24, 25, 26, 28 AND 41.
2,968,120, CANC. INT. CL. 28.
2,968,166, CANC. INT. CL. 28.
2,968,167, CANC. INT. CL. 28.
2,968,316, CANC. INT. CL. 28.
2,968,318, CANC. INT. CL. 28.
2,968,319, CANC. INT. CL. 28.
2,968,320, CANC. INT. CL. 28.
2,968,355, CANC. INT. CL. 28.
2,968,362, CANC. INT. CL. 28.
2,968,379, CANC. INT. CL. 28.
2,968,537, CANC. INT. CL. 28.
2,968,549, CANC. INT. CL. 28.
4,117,021, PUB. 10-4-2011. INT. CL. 28.
4,117,170, PUB. 1-10-2012. INT. CL. 28.
4,117,281, PUB. 1-10-2012. INT. CL. 28.
4,117,406, PUB. 1-10-2012. INT. CL. 28.
4,117,407, PUB. 1-10-2012. INT. CL. 28.

MAURICES INCORPORATED, DULUTH, MN:
4,119,294, MULTIPLE CLASS, INT. CLS. 35 AND 41.

MAURIZIO ARDUINI, ITALY:
4,116,771, PUB. 1-10-2012. INT. CL. 32.

MAVOR, SALLEY, WOODS HOLE, MA, DBA WEE FOLK STUDIO:
2,467,648, CANC. INT. CL. 28.

MAX MARA INTERNATIONAL S.A., LUXEMBOURG:
4,116,772, PUB. 1-10-2012. MULTIPLE CLASS, INT. CLS.
18 AND 25.

MAX WORX, LLC, AUSTIN, TX:
4,118,419, PUB. 1-10-2012. INT. CL. 3.
4,118,421, PUB. 1-10-2012. INT. CL. 3.

MAX-VIZ, INC., PORTLAND, OR:
2,968,377, CANC. INT. CL. 42.

MAXEY, AVA LISA, SHERWOOD, AR:
4,118,812, INT. CL. 25.

MAYAN PARROT, LLC, KEY WEST, FL, DBA GREEN PARROT BAR:
4,118,731, PUB. 1-10-2012. INT. CL. 43.

MAYE, RICHARD WARREN ADAMFO, BRONX, NY, AKA WILL AMAZE:
4,119,625, INT. CL. 9.

MAYER, JAMES, LINCOLN, NE:
3,542,801, COR. INT. CL. 28.

MAYHEW & ASSOCIATES, INC., IRVINE, CA:
4,119,058, INT. CL. 29.

MAYRON COLE PIANO CONSERVATORY, INC., GONZALES, TX:
4,117,966, PUB. 1-10-2012. INT. CL. 41.

MB FIELD SERVICES, INC., ATLANTA, GA:
4,119,482, INT. CL. 36.
4,119,493, INT. CL. 36.
4,119,652, INT. CL. 36.

MB FINANCIAL BANK, N.A., ROSEMONT, IL:
2,466,859, CANC. INT. CL. 9.

MBCR COMPANY, EAGLE, ID:
2,968,306, CANC. INT. CL. 25.

MBEACH1, LLLP, MIAMI BEACH, FL:
4,119,746, MULTIPLE CLASS, INT. CLS. 35 AND 36.

- MCBRIDE, LAUREN D, SCOTTSDALE, AZ, DBA HOLISTICALLY FIT:
4,117,790, PUB. 1-10-2012. INT. CL. 44.
- MCCLORY, MICHAEL R., ARLINGTON, VA:
4,118,077, PUB. 1-10-2012. INT. CL. 41.
- MCCONNELL, MICHAEL, SEATTLE, WA:
4,118,074, PUB. 1-10-2012. INT. CL. 43.
- MCDONALD, NOEL, KINGSTON-UPON-THAMES, UNITED KINGDOM:
4,117,031, PUB. 1-10-2012. MULTIPLE CLASS, INT. CLS. 29, 30 AND 32.
- MCELRATH-SLADE, ROSE A., MCLEAN, VA, DBA NATIONAL ASSOCIATION OF AFRICAN AMERICANS IN HUMAN RESOURCES:
2,529,016. REN. 2-23-12. INT. CL. 42.
- MCFARLAND CASCADE HOLDING, INC., TACOMA, WA, CASCADE POLE COMPANY, TACOMA, WA:
1,220,905. REN. 2-23-12. INT. CL. 19.
- MCGUIRE PERFORMANCE SOLUTIONS, INC., SCOTTSDALE, AZ:
4,118,523, PUB. 1-10-2012. INT. CL. 36.
- MCGUIRE, PAULA T., LEXINGTON, KY:
4,119,224, INT. CL. 43.
- MCILNAY, KATHLEEN P., HOLLIDAYSBURG, PA AND MCILNAY, DENNIS P., HOLLIDAYSBURG, PA:
2,968,619, CANC. INT. CL. 41.
- MCKESSON TECHNOLOGIES INC., ALPHARETTA, GA:
2,968,059, CANC. MULTIPLE CLASS, INT. CLS. 35, 38, 41, 44 AND 45.
- MCKINLEY SPRINGS, LLC, PROSSER, WA:
2,968,431, CANC. INT. CL. 33.
- MCMURRAY-STIVERS, LISA, EUREKA, CA:
2,967,333, CANC. INT. CL. 21.
- MCPOLO (USA) CORP., CORONA, NY:
2,968,650, CANC. INT. CL. 18.
- MDM GROUP, LTD., FT. LAUDERDALE, FL:
2,467,459, CANC. MULTIPLE CLASS, INT. CLS. 35 AND 42.
- MDR OUTDOOR GROUP, INC., HAMDEN, CT:
2,968,528, CANC. INT. CL. 28.
- MDT MICRO DIAMOND TECHNOLOGIES LTD, AFULA, ISRAEL:
4,119,323, INT. CL. 10.
- ME & MY BIG IDEAS, INC., LAKE FOREST, CA:
2,968,325, CANC. INT. CL. 16.
- ME PARKSIDE, L.P., SKOKIE, IL:
2,466,952, CANC. INT. CL. 37.
- MEADOWBROOK, INC., SOUTHFIELD, MI:
4,116,893, PUB. 1-10-2012. INT. CL. 42.
- MEADOWS, LEWIS G, DUNKIRK, MD:
4,119,093, INT. CL. 39.
- MEADWESTVACO CORPORATION, RICHMOND, VA:
2,576,121. REN. 2-22-12. INT. CL. 21.
- MEBLE KLER-PIOTR KLER, 46-380 DOBRODZIEN, POLAND:
2,967,659, CANC. INT. CL. 20.
- MEBO INTERNATIONAL, INC., SUNNYVALE, CA:
2,656,764. REN. 2-22-12. MULTIPLE CLASS, INT. CLS. 3 AND 5.
- MECHANICS HELPER, INC., BLOOMINGTON, IN, DBA HI-TEC INDUSTRIES:
4,118,475, PUB. 1-10-2012. INT. CL. 17.
- MECKAUER, FREDERICK, SANTA BARBARA, CA:
4,118,853, INT. CL. 32.
- MECKLENBURG, BRENT O., WARD, AR, DBA MECKWEAR:
4,119,771, INT. CL. 25.
- MED ENCLOSURE LLC, SARASOTA, FL:
2,967,795, CANC. INT. CL. 10.
- MED ENCLOSURE, LLC, SARASOTA, FL:
2,968,145, CANC. INT. CL. 10.
- MEDAMERICA, INC., EMERYVILLE, CA:
2,658,421. REN. 2-17-12. INT. CL. 36.
- MEDAXIOM, INC., ATLANTIC BEACH, FL:
2,604,508. REN. 2-22-12. INT. CL. 35.
- MEDGE PLATFORMS, INC., NEW YORK, NY:
2,602,102. REN. 2-23-12. INT. CL. 9.
- MEDIASPAN GROUP, INC., MORRISVILLE, NC:
2,467,074, CANC. INT. CL. 9.
- MEDICAL LEGAL NURSE CONSULTANTS, LLC, LANCASTER, PA:
4,118,060, PUB. 1-10-2012. INT. CL. 35.
- MEDICAL SECURITY CARD COMPANY, LLC, TUCSON, AZ:
2,968,022, CANC. INT. CL. 16.
- MEDICARECOMPAREUSA, BELLINGHAM, WA:
4,119,875, INT. CL. 36.
- MEDICINE WORLD ENTERPRISES, LLC, SOLEBURY, PA:
4,118,980, INT. CL. 41.
- MEDLINE INDUSTRIES, INC., MUNDELEIN, IL:
2,968,482, CANC. INT. CL. 35.
- MEDNEST, LIMITED LIABILITY COMPANY, PRINCETON, NJ:
4,119,375, INT. CL. 35.
- MEDPRO SYSTEMS, LLC, MT. ARLINGTON, NJ:
3,817,093, AM. INT. CL. 35.
- MEDRED, LLC, WASHINGTON, DC:
4,116,610, PUB. 1-19-2010. MULTIPLE CLASS, INT. CLS. 42 AND 44.
- MEDTRONIC, INC., MINNEAPOLIS, MN, DLP, INC., GRAND RAPIDS, MI:
1,677,484. REN. 2-17-12. INT. CL. 10.
- MEDTRONIC, INC., MINNEAPOLIS, MN:
1,679,841. REN. 2-22-12. INT. CL. 10.
- 4,118,867, INT. CL. 10.
- MEDUZA SYSTEMS LLC, IRVINE, CA:
4,119,102, INT. CL. 9.
- MEGATURBO GROUP INTERNATIONAL, LLC, DORAL, FL:
4,119,459, INT. CL. 11.
- MEGAWAVE CORPORATION, LANSING, MI:
4,118,937, INT. CL. 35.
- MEHR'S TEXTILE CORP., ROBBINSVILLE, NJ:
2,467,322, CANC. INT. CL. 35.
- MEIJER INC, GRAND RAPIDS, MI:
1,192,121. REN. 2-21-12. MULTIPLE CLASS, INT. CLS. 40 AND 42.
- MEILLAND INTERNATIONAL S.A., 83340 LE LUC EN PROVEN, FRANCE:
4,117,331, PUB. 1-10-2012. INT. CL. 31.
- MEKKITTKIKUL, ADISAK, MOUNTAIN VIEW, CA:
4,117,115, PUB. 1-10-2012. INT. CL. 28.
- MELISBEK, ULAN, SAN JOSE, CA:
4,117,786, PUB. 1-10-2012. INT. CL. 45.
- MELODY TEMPLETON AND JOSE ROGELIO CANTU, LOS ANGELES, CA:
2,967,644, CANC. INT. CL. 35.
- MENDY, PIERRE ETIENNE, 76 - 140 LE PETIT-QUEVILLY, NORMANDIE, FRANCE:
2,967,510, CANC. MULTIPLE CLASS, INT. CLS. 18 AND 25.
- MENKE & ASSOCIATES, INC., SAN FRANCISCO, CA, DBA MENKE ESOPONLINE SERVICES AND THE MENKE GROUP, INC., SAN FRANCISCO, CA, AKA THE MENKE GROUP:
4,117,653, PUB. 1-10-2012. INT. CL. 36.
- MENORAH MANOR, INC., ST. PETERSBURG, FL:
4,117,581, PUB. 1-10-2012. INT. CL. 44.
- MER+GE LLC, SAN MARCOS, TX, DBA MER+GE:
4,117,734, PUB. 1-10-2012. INT. CL. 25.
- MERCK KGAA, D-64293 DARMSTADT, FED REP GERMANY:
2,467,572. REN. 2-22-12. INT. CL. 9.
- 2,491,084. REN. 2-21-12. INT. CL. 11.
- 2,533,607. REN. 2-22-12. INT. CL. 9.
- 2,560,459. REN. 2-22-12. INT. CL. 11.
- MERCK KGAA, 64293 DARMSTADT, FED REP GERMANY:
4,118,119, PUB. 1-10-2012. INT. CL. 2.
- MERCK SHARP & DOHME CORP., WHITEHOUSE STATION, NJ:
2,522,920. REN. 2-17-12. INT. CL. 5.
- MERIDIAN MANAGEMENT CORPORATION, PONTE VEDRA BEACH, FL:
2,968,085, CANC. INT. CL. 12.

MERIT TURIZM YATIRIM VE ISLETME ANONIM SIRKETI, TURKEY:
4,116,847, PUB. 1-10-2012. MULTIPLE CLASS, INT. CLS. 25 AND 37.

MERLE NORMAN COSMETICS, INC., LOS ANGELES, CA:
935,078. REN. 2-17-12. U.S. CL. 51 (INT. CL. 5).

MERRICK'S, INC., MIDDLETOWN, WI, MERRICK DRY MILK, INC., UNION CENTER, WI, AKA MERRICK FOODS:
1,186,016. REN. 2-22-12. INT. CL. 29.

META PHARMACEUTICAL SERVICES, BLUE BELL, PA:
4,119,038, MULTIPLE CLASS, INT. CLS. 9 AND 42.
4,119,040, MULTIPLE CLASS, INT. CLS. 35 AND 41.

METAL ROOF INNOVATIONS, LTD., COLORADO SPRINGS, CO:
4,118,919, INT. CL. 6.

METHODSHOP, LLC, HOBOKEN, NJ:
4,117,417, PUB. 1-10-2012. INT. CL. 38.
4,117,418, PUB. 1-10-2012. INT. CL. 38.

METIER, LTD, SANTA ROSA, CA:
4,117,268, PUB. 1-10-2012. INT. CL. 9.

METRO CORP., PHILADELPHIA, PA:
2,467,981, CANC. INT. CL. 16.

METRO INDUSTRIES LLC, SEATTLE, WA, DBA ELLIOTT BAY INDUSTRIES:
4,117,974, PUB. 1-10-2012. INT. CL. 40.

METRO MOMS NETWORK, L.L.C., HOBOKEN, NJ:
4,119,834, INT. CL. 9.

METRO/THEBE, INC., TORRANCE, CA:
2,466,814, CANC. MULTIPLE CLASS, INT. CLS. 11, 20 AND 21.

METROPCS WIRELESS, INC., RICHARDSON, TX:
2,967,544, CANC. INT. CL. 38.

METROPOLITAN LIFE INSURANCE COMPANY, NEW YORK, NY:
4,118,680, PUB. 1-10-2012. INT. CL. 43.
4,118,685, PUB. 1-10-2012. INT. CL. 43.
4,119,450, INT. CL. 36.

METSO LINDEMANN GMBH, 40231 DÜSSELDORF, FED REP GERMANY:
4,116,857, PUB. 1-10-2012. INT. CL. 7.

METZGERMEISTER & RESEARCH CORP., CIALES, PUERTO RICO:
4,118,835, MULTIPLE CLASS, INT. CLS. 29 AND 30.

MEXICAN FOOD SPECIALTIES, INC., LIVONIA, MI:
1,658,410. REN. 2-21-12. INT. CL. 30.

MEYER COUNTRY FARMS LTD., SCOTTSDALE, AZ:
2,967,694, CANC. INT. CL. 40.

MEYER INTELLECTUAL PROPERTIES LIMITED, KOWLOON, HONG KONG, CHINA, PRESTIGE GROUP LIMITED, THE, LONDON E.C. 1, ENGLAND:
723,479. REN. 2-21-12. U.S. CL. 13 (INT. CL. 21).

MEYNARD DESIGNS, INC., WALTHAM, MA:
2,668,138. REN. 2-22-12. INT. CL. 25.

MEZOTRACE CORPORATION, WINNEMUCCA, NV:
4,119,812, INT. CL. 5.

MGA ENTERTAINMENT, INC., NORTH HILLS, CA:
2,967,585, CANC. INT. CL. 28.

MHC MEDICAL PRODUCTS, LLC, FAIRFIELD, OH:
4,117,945, PUB. 1-10-2012. MULTIPLE CLASS, INT. CLS. 5 AND 10.

MI VISION CO., LTD., SEOUL, REPUBLIC OF KOREA:
2,967,477, CANC. INT. CL. 9.

MIAMI BEACH WATERSPORTS CENTER INC, MIAMI BEACH, FL:
4,117,746, PUB. 1-10-2012. INT. CL. 41.

MICHAEL AVETISOV, SHERMAN OAKS, CA:
4,119,536, INT. CL. 33.

MICHAEL BAKER, LOUISVILLE, KY:
4,118,321, PUB. 1-10-2012. INT. CL. 41.

MICHAEL COCHRANE, CLEVELAND, OH:
4,117,217, PUB. 1-10-2012. INT. CL. 30.

MICHAEL E. MURPHY, DALLAS, TX:
4,117,272, PUB. 1-10-2012. MULTIPLE CLASS, INT. CLS. 7, 16 AND 32.

MICHAEL G. KESSLER & ASSOCIATES, LTD., NEW YORK, NY:
2,540,376. REN. 2-19-12. MULTIPLE CLASS, INT. CLS. 35 AND 42.

MICHAEL IAN GOLF LLC, CHICAGO, IL:
4,119,729, INT. CL. 25.

MICHAEL J PAULHUS, LARGO, FL, DBA THE PUZZLE PAGES AND CHERYL A MCKEE, LARGO, FL, DBA THE PUZZLE PAGES:
4,119,857, INT. CL. 35.

MICHAEL RIVERA, PORT JEFFERSON STATION, NY:
4,119,155, INT. CL. 25.

MICHAEL Z. WANG, GREAT NECK, NY:
4,117,954, PUB. 1-10-2012. INT. CL. 43.

MICHAELS STORES PROCUREMENT COMPANY, INC., GRAND PRAIRIE, TX:
3,042,415, CANC. MULTIPLE CLASS, INT. CLS. 35 AND 41.

MICHEL VELASCO, FERNANDO IGNACIO, MR., GUADAJARA, MEXICO:
1,201,281. REN. 2-22-12. INT. CL. 28.

MICHELIN NORTH AMERICA, INC., GREENVILLE, SC:
2,967,598, CANC. INT. CL. 12.

MICHIGAN MOLECULAR INSTITUTE, MIDLAND, MI, DBA IMPACT ANALYTICAL:
4,118,234, PUB. 1-10-2012. INT. CL. 42.

MICHIGAN SPORTING GOODS DISTRIBUTORS, INC., GRAND RAPIDS, MI:
2,468,538, CANC. INT. CL. 22.

MICRIUM, INC., WESTON, FL:
4,117,658, PUB. 1-10-2012. MULTIPLE CLASS, INT. CLS. 9, 16, 41 AND 42.

MICRO DISTRIBUTORS, INC., PEORIA, IL:
2,968,125, CANC. INT. CL. 9.

MICRODEXTERITY SYSTEMS, INC., ALBUQUERQUE, NM:
2,968,075, CANC. MULTIPLE CLASS, INT. CLS. 7 AND 10.

MICROJET TECHNOLOGY CO., LTD, HSINCHU, TAIWAN:
4,119,144, INT. CL. 7.
4,119,145, INT. CL. 9.
4,119,146, INT. CL. 2.
4,119,147, INT. CL. 7.

MICROM INTERNATIONAL GMBH, WALLDORF, FED REP GERMANY:
4,117,530, PUB. 1-10-2012. INT. CL. 9.

MICROMASS UK LIMITED, WYTHENSHAW MANCHESTER, UNITED KINGDOM:
2,467,581, CANC. INT. CL. 9.

MICRON SYSTEMS INC., GLEN ROCK, NJ:
2,584,070. REN. 2-21-12. INT. CL. 9.

MICROSOFT CORPORATION, REDMOND, WA:
2,968,651, CANC. INT. CL. 42.

MICROSTONE BUILDING SYSTEMS, LLC, SAN ANTONIO, TX:
2,467,012, CANC. INT. CL. 1.

MIDDLE PATH MEDICINE, ARROYO GRANDE, CA:
4,118,034, PUB. 1-10-2012. INT. CL. 44.
4,118,035, PUB. 1-10-2012. INT. CL. 35.

MIDLAND DESIGN, LLC, WEST HOLLYWOOD, CA:
4,117,075, PUB. 1-10-2012. INT. CL. 28.

MIDLIFE COLLAGE, LLC, LAS VEGAS, NV:
4,119,672, INT. CL. 42.

MIDTRONICS, INC., WILLOWBROOK, IL:
1,699,763. REN. 2-23-12. INT. CL. 9.

MIDWAY AMUSEMENT GAMES, LLC, CHICAGO, IL:
2,468,413, CANC. INT. CL. 28.

MILES, DAVID, WINFIELD, AL:
4,119,287, INT. CL. 25.

MILKIMCHI INC, NEW YORK, NY, DBA MOTHER-IN-LAW'S KIMCHI:
4,117,221, PUB. 1-10-2012. INT. CL. 29.

MILLER, JAMES, SAUSALITO, CA:
2,468,468, CANC. INT. CL. 3.

MILLIONS OF MILKSHAKES, INC., WEST HOLLYWOOD, CA:
4,117,477, PUB. 1-10-2012. MULTIPLE CLASS, INT. CLS. 25, 29, 30 AND 43.

MILMAR FOOD GROUP, LLC, GOSHEN, NY:
2,967,529, CANC. MULTIPLE CLASS, INT. CLS. 29 AND 30.

- MILTON HOLDINGS, INC., EAST GREENWICH, RI, DBA MERIDIAN PRINTING:
2,602,317, CANC. INT. CL. 42.
- MILYLI INC., CHICAGO, IL, AKA MILYLI:
4,116,984, PUB. 1-10-2012. INT. CL. 9.
- MIND-BUGS LLC, SANDY SPRINGS, GA:
4,119,042, MULTIPLE CLASS, INT. CLS. 16, 35 AND 45.
- MINDPEACE CINCINNATI, INC., CINCINNATI, OH:
4,117,943, PUB. 1-10-2012. INT. CL. 35.
- MINE SAFETY APPLIANCES COMPANY, PITTSBURGH, PA:
2,468,523, CANC. INT. CL. 9.
- MINERALLAC COMPANY, HAMPSHIRE, IL, MINERAL-LAC ELECTRIC COMPANY, ADDISON, IL:
1,698,759, REN. 2-22-12. INT. CL. 6.
- MINETECH, INC., RIDGEFIELD, CT:
2,530,496, REN. 2-22-12. MULTIPLE CLASS, INT. CLS. 9 AND 42.
2,530,498, REN. 2-22-12. MULTIPLE CLASS, INT. CLS. 9 AND 42.
- MING FONG YANG, NEW TAIPEI CITY, TAIWAN:
4,117,578, PUB. 1-10-2012. INT. CL. 31.
- MINISTERO DELLE POLITICHE AGRICOLE;; ALIMEN-TARI E FORESTALI -; DIPARTIMENTO DELLE POLI-TICHE, COMPETITIVE DEL MONDO RURALE; E DELLA QUALITA' -; DIREZIONE GENERALE PER LO SVILUP-PO AGROALIMENTARE;; LA QUALITA' E LA TUTELA; DEL CONSUMATORE, ROMA, ITALY:
4,116,691, PUB. 1-10-2012. INT. CL. 29.
- MINISTRY TRAVEL, LLC, SAYREVILLE, NJ:
4,119,089, INT. CL. 39.
- MIRADA MEDICAL LIMITED, OXFORD, OXFORDSHIRE, UNITED KINGDOM:
4,119,154, INT. CL. 9.
- MIRAGE HEALTH GROUP LIMITED, HERTFORDSHIRE AL7 3AX, UNITED KINGDOM:
4,116,981, PUB. 1-10-2012. INT. CL. 10.
- MIRANDA, BERTHA, WESTLAKE VILLAGE, CA:
2,545,478, REN. 2-22-12. INT. CL. 9.
- MIRATEC SYSTEMS, INC, SAINT PAUL, MN:
4,119,070, INT. CL. 35.
- MISSION: ALLERGY, INC., HAWLEYVILLE, CT:
4,117,555, PUB. 1-10-2012. MULTIPLE CLASS, INT. CLS. 20, 24 AND 35.
- MISSY ENTERPRISES, INC., STREAMWOOD, IL:
4,118,342, PUB. 1-10-2012. INT. CL. 21.
- MITCHELL, GAIL R., NEW YORK, NY:
4,119,632, INT. CL. 37.
- mitsubishi electric corporation, CHIYODA-KU, JAPAN:
2,965,417, CANC. INT. CL. 9.
- MITSUBISHI PENCIL COMPANY, LIMITED, JAPAN:
4,116,860, PUB. 1-10-2012. INT. CL. 16.
- MIX BRANDS LLC, WILTON, CT:
4,118,892, INT. CL. 3.
- MIXED BUSINESS INC., NEW YORK, NY:
4,119,073, MULTIPLE CLASS, INT. CLS. 25 AND 35.
- MIXPO PORTFOLIO BROADCASTING INC., VANCOUVER, BC, CANADA:
2,968,514, CANC. INT. CL. 9.
- MLA MULTIBRAND HOLDINGS, INC., VERNON, CA:
2,968,181, CANC. INT. CL. 18.
4,118,869, INT. CL. 3.
- MMH PTY LTD, AUSTRALIA:
3,976,524, COR. INT. CL. 9.
- MMJIP, LLC, SAN FRANCISCO, CA:
4,119,290, INT. CL. 35.
- MNEMONICS, INC., MOUNT LAUREL, NJ:
4,118,373, PUB. 1-10-2012. INT. CL. 9.
- MOBIO LABORATORIES, INC., CARLSBAD, CA:
4,119,772, INT. CL. 2.
- MODERN APIZZA, INC., NEW HAVEN, CT:
4,119,409, INT. CL. 43.
- MODERN FAMILY SURROGACY CENTER, INC, EL CA-JON, CA:
4,117,377, PUB. 1-10-2012. INT. CL. 45.
- MODERN MEXICAN RESTAURANTS, INC., DENVER, CO:
4,118,851, INT. CL. 43.
- MOEN INCORPORATED, NORTH OLMSTED, OH:
1,671,054, REN. 2-22-12. INT. CL. 11.
- MOHAWK CARPET DISTRIBUTION, INC, CHATSWORTH, GA:
2,522,681, REN. 2-22-12. INT. CL. 27.
- MOLECULAR PROBES, INC., EUGENE, OR:
1,706,084, REN. 2-17-12. INT. CL. 1.
- MOLINA, CARMEN L., PALM BEACH GARDENS, FL, DBA SMALL HOME BUSINESS:
4,119,490, INT. CL. 25.
- MOMENTUM DISTRIBUTION CORP., HOUSTON, TX, DBA AIR STRATEGIES:
4,118,585, PUB. 1-10-2012. INT. CL. 7.
4,118,595, PUB. 1-10-2012. INT. CL. 7.
- MONAD CORPORATION, WILMINGTON, DE, DBA MON-AD:
4,118,661, PUB. 1-10-2012. INT. CL. 35.
- MONAG INTERNATIONAL INC., VICTOR, NY:
2,681,423, REN. 2-21-12. INT. CL. 25.
- MONARCH BEVERAGE CO., INC., INDIANAPOLIS, IN:
4,119,874, INT. CL. 35.
- MONAVIE LLC, SOUTH JORDAN, UT:
4,118,084, PUB. 1-10-2012. INT. CL. 36.
4,118,697, PUB. 1-10-2012. INT. CL. 5.
- MONKEYPLATES LIMITED, UNITED KINGDOM:
4,116,867, PUB. 1-10-2012. INT. CL. 45.
- MONKUBE B.V.B.A., B-1080 SINT-JANS-MOLENBEEK, BEL-GIUM:
4,116,856, PUB. 1-10-2012. MULTIPLE CLASS, INT. CLS. 9 AND 16.
- MONSTER ENERGY COMPANY, CORONA, CA:
2,593,887, REN. 2-23-12. INT. CL. 32.
- MONTANA STATE UNIVERSITY, BOZEMAN, MT:
4,117,098, PUB. 1-10-2012. INT. CL. 41.
- MONTICELLO DRUG COPMPANY, JACKSONVILLE, FL:
926,713, REN. 2-22-12. U.S. CL. 18 (INT. CL. 5).
- MONTRES TUDOR SA, CH-1211 GENÈVE 26, SWITZER-LAND:
4,116,822, PUB. 1-10-2012. INT. CL. 14.
4,116,861, PUB. 1-10-2012. INT. CL. 14.
- MOREY' S MUSIC STORE, INC., LAKEWOOD, CA:
2,651,038, REN. 2-17-12. INT. CL. 15.
- MORGAN STANLEY, NEW YORK, NY:
2,968,441, CANC. INT. CL. 36.
- MORGANS GROUP LLC, NEW YORK, NY:
2,467,803, CANC. INT. CL. 3.
- MORIYAMA SANGYO KABUSHIKI KAISHA, TOKYO, JAPAN:
2,556,254, REN. 2-17-12. INT. CL. 11.
- MORRIS, RUSSELL, CALGARY, AB, CANADA:
2,967,512, CANC. INT. CL. 9.
- MORRISON & FOERSTER, LLP, SAN FRANCISCO, CA:
2,481,879, REN. 2-17-12. INT. CL. 42.
- MOSHER, EUGENE LEWIS, EUGENE, OR, AKA VIEW-TOUCH:
2,428,095, REN. 2-17-12. MULTIPLE CLASS, INT. CLS. 9, 35 AND 42.
- MOSTER, WYNNE & RESSLER, P.C., AUSTIN, TX:
4,118,033, PUB. 1-10-2012. INT. CL. 45.
- MOTHER MURPHY'S LABORATORIES, INC., GREEN-SBORO, NC, FORMERLY SOUTHERN LABORATORIES, INC.:
4,117,670, PUB. 1-10-2012. MULTIPLE CLASS, INT. CLS. 30 AND 40.
- MOTHERMUSCLE, LLC, HUNTINGTON, NY:
4,117,857, PUB. 1-10-2012. MULTIPLE CLASS, INT. CLS. 9 AND 28.
- MOTION THERAPEUTICS, INC., SAN FRANCISCO, CA:
4,119,186, INT. CL. 10.
4,119,187, INT. CL. 10.
4,119,188, INT. CL. 10.
- MOTION1, INC., CARMEL, IN:
4,119,099, INT. CL. 35.
- MOTOR DEALER SERVICES GROUP, LLC, HENDERSON, NV:
4,117,981, PUB. 1-10-2012. INT. CL. 36.

MOTOROLA TRADEMARK HOLDINGS, LLC, LIBERTY-VILLE, IL:
2,968,375, CANC. MULTIPLE CLASS, INT. CLS. 9 AND 38.

MOTOROLA, INC., PASADENA, CA:
2,967,418, CANC. MULTIPLE CLASS, INT. CLS. 1, 5, 9 AND 10.

MOTOVEND, LLC, RACINE, WI:
4,118,178, PUB. 1-10-2012. INT. CL. 43.

MOTRICITY, INC., BELLEVUE, WA:
2,968,290, CANC. INT. CL. 9.

MOTT, STEPHEN CRAIG, STAMFORD, CT:
4,118,482, PUB. 1-10-2012. INT. CL. 35.

MOUNT RAINIER COFFEE COMPANY, PUYALLUP, WA:
4,119,865, INT. CL. 30.

MOUNT VERNON LADIES' ASSOCIATION OF THE UNION, THE, MOUNT VERNON, VA:
2,556,946. REN. 2-22-12. INT. CL. 42.

MOUNTAIN MEADOWS PRODUCTS, INC., LEWISTOWN, MT:
1,676,948. REN. 2-21-12. INT. CL. 31.

MOUNTAIN VIEW SEEDS, LTD., SALEM, OR:
2,467,270, CANC. INT. CL. 31.

MOUNTAINVIEW CAPITAL HOLDINGS, LLC, DENVER, CO:
4,117,069, PUB. 1-10-2012. INT. CL. 36.

MOVE PROS LLC, OCALA, FL, DBA THE VILLAGES MOVING SERVICE:
4,118,240, PUB. 1-10-2012. INT. CL. 39.

MOVING OFF CAMPUS, ST. LOUIS, MO:
4,117,850, PUB. 1-10-2012. INT. CL. 35.

MOXIE'S RESTAURANTS, LIMITED PARTNERSHIP, CALGARY, ALBERTA T2J 6A5, CANADA:
2,965,424, CANC. INT. CL. 42.

MPC PROPERTIES, LLC, JACKSON HEIGHTS, NY:
4,118,866, INT. CL. 30.

MR. GATTI'S, LP, AUSTIN, TX:
4,117,046, PUB. 1-10-2012. INT. CL. 41.

MR. HOT BREAD INC., NEW YORK, NY:
2,539,058. REN. 2-22-12. MULTIPLE CLASS, INT. CLS. 35 AND 42.

MR. MOVER, LLC, CLEARWATER, FL:
4,117,040, PUB. 1-10-2012. INT. CL. 39.

MRPCO, LLC, WHITEFISH, MT:
4,118,580, PUB. 1-10-2012. INT. CL. 43.

MSR HOTELS & RESORTS, INC., BOSTON, MA:
2,527,472. REN. 2-21-12. MULTIPLE CLASS, INT. CLS. 25, 28, 36 AND 41.

MTD PRODUCTS INC, VALLEY CITY, OH, DESA INDUSTRIES INC., COCKEYSVILLE, MD:
929,505. REN. 2-22-12. U.S. CL. 23 (INT. CL. 7).

MTI ENTERPRISES, INC, NEW YORK, NY, DBA MUSIC THEATRE INTERNATIONAL:
2,526,305. REN. 2-22-12. INT. CL. 41.
2,526,305, CANC. INT. CL. 42.

MTM SERVICES, HOLLY SPRINGS, NC:
4,117,610, PUB. 1-10-2012. INT. CL. 35.

MUKENBRUN, CEM, ENGLEWOOD, NJ, DBA PIPES UNLIMITED:
1,738,572. REN. 2-21-12. INT. CL. 34.

MUL-T-LOCK TECHNOLOGIES LTD., YAVNE, ISRAEL:
4,117,519, PUB. 1-10-2012. INT. CL. 9.

MULLET CABINET, MILLERSBURG, OH:
2,967,608, CANC. INT. CL. 20.

MULTI-AD SERVICES, INC., PEORIA, IL:
1,161,254. REN. 2-22-12. INT. CL. 35.

MULTIPLEX PROPERTIES, INC., WILMINGTON, DE:
2,968,071, CANC. INT. CL. 35.

MULVIHILL, HENRY N. JR., RICHARDSON, TX:
2,473,178. REN. 2-22-12. INT. CL. 36.

MURDOCK WEBBING COMPANY, INC., CENTRAL FALLS, RI:
1,729,425. REN. 2-23-12. INT. CL. 22.

MURO, MARYANN, WAYNE, NJ:
2,967,412, CANC. INT. CL. 3.

MURPHY OIL USA, INC., EL DORADO, AR:
291,502. REN. 2-17-12. U.S. CL. 15 (INT. CL. 4).

MURPHY, ELIZABETH, KELLER, TX AND MEISGEIER, CHARLES, RICHMOND, TX:
4,118,610, PUB. 1-10-2012. INT. CL. 41.

MURRAY & YOUNG, NAPERVILLE, IL:
4,118,553, PUB. 1-10-2012. INT. CL. 45.

MUSCULAR DYSTROPHY ASSOCIATION, INC., TUCSON, AZ:
4,119,728, MULTIPLE CLASS, INT. CLS. 36, 41, 42, 43 AND 44.

MUSE CONSULTING GROUP, LLC, NEW YORK, NY:
4,117,359, PUB. 1-10-2012. INT. CL. 45.

MUSELLO, DAMIAN R., SOMERVILLE, MA:
4,119,576, INT. CL. 35.

MUSICAL EXPERIENCE, INC., NEW YORK, NY, DBA MUSICAL KIDS INTERNATIONAL:
4,119,071, MULTIPLE CLASS, INT. CLS. 9, 16 AND 41.

MUSL TV, LLC, VAN NUYS, CA:
4,117,006, PUB. 1-10-2012. MULTIPLE CLASS, INT. CLS. 38 AND 41.

MUST HAVE PRODUCTS, INC., MEQUON, WI:
4,119,321, INT. CL. 25.

MX USA, INC., SPARKS GLENCOE, MD:
4,118,196, PUB. 1-10-2012. INT. CL. 44.

MY ACADEMY, LLC, LAGUNA HILLS, CA:
4,116,563, PUB. 1-10-2012. INT. CL. 41.

MY FATHER CIGARS, INC., MIAMI, FL:
4,117,304, PUB. 1-10-2012. INT. CL. 34.

MYAUTONETWORK, INC., TEMPE, AZ:
4,117,604, PUB. 1-10-2012. INT. CL. 35.

MYBEAUTYCENTER.COM, LLC, NEW YORK, NY:
2,967,468, CANC. INT. CL. 3.

MYERS, WILLIAM, NEW YORK, NY:
4,118,751, INT. CL. 25.

MYOBIS GMBH, FED REP GERMANY:
4,116,776, PUB. 1-10-2012. MULTIPLE CLASS, INT. CLS. 35, 36, 38, 39, 41 AND 43.

MYOGRID INC., MISSISSAUGA, CANADA:
4,117,049, PUB. 1-10-2012. INT. CL. 25.
4,117,199, PUB. 1-10-2012. INT. CL. 25.
4,117,200, PUB. 1-10-2012. INT. CL. 25.
4,117,201, PUB. 1-10-2012. INT. CL. 25.

MYVOICE, INC., TORONTO, ONTARIO, CANADA:
4,119,616, INT. CL. 42.

M7 CORPORATION, VERBANK, NY, DBA METROGRASS:
4,118,898, INT. CL. 27.

N.V. HOLMATRO, 4941 VL RAAMSDONKSVEER, NETHERLANDS:
1,190,443. REN. 2-17-12. INT. CL. 7.

N.V. ORGANON, OSS, NETHERLANDS:
2,966,399, CANC. INT. CL. 42.

NAA'ILA ENTERTAINMENT, BEVERLY HILLS, CA:
4,117,146, PUB. 1-10-2012. INT. CL. 41.

NAC VITAMIN COMPANY, INC., HICKSVILLE, NY:
2,967,805, CANC. INT. CL. 5.

NAEEM KHALID, ROCKY HILL, CT:
4,116,931, PUB. 1-10-2012. INT. CL. 4.

NAISMITH-BEELEY, ILDE, BALMAIN, AUSTRALIA AND NAISMITH-BEELEY, MARK, BALMAIN, AUSTRALIA:
4,117,557, PUB. 1-10-2012. INT. CL. 25.

NALGE NUNC INTERNATIONAL CORPORATION, ROCHESTER, NY:
2,967,436, CANC. INT. CL. 21.

NALLEY, MARK, MURRIETA, CA:
4,118,884, INT. CL. 28.

NAMCO BANDAI GAMES AMERICA INC., SAN JOSE, CA:
4,118,642, PUB. 1-10-2012. INT. CL. 9.

NAMCO BANDAI GAMES INC., TOKYO, JAPAN:
4,118,870, MULTIPLE CLASS, INT. CLS. 9 AND 41.

NANIUM, S.A., 4485-629 VILA DO CONDE, PORTUGAL:
4,116,884, PUB. 1-10-2012. MULTIPLE CLASS, INT. CLS. 9, 35, 37, 39, 40 AND 42.

NANOSONIC, INC., PEMBROKE, VA:
4,119,148, INT. CL. 2.

NANOSPHERE, INC., ALACHUA, FL:
2,967,415, CANC. MULTIPLE CLASS, INT. CLS. 9 AND 10.

NANOSYS, INC., PALO ALTO, CA:
4,118,843, INT. CL. 5.

- NANTERO, INC., WOBURN, MA:
2,967,524, CANC. INT. CL. 9.
- NAPLES BOTANICAL GARDEN, INC., NAPLES, FL, DBA
NAPLES BOTANICAL GARDEN, INC.:
4,117,772, PUB. 1-10-2012. INT. CL. 41.
- NATIONAL AGRICULTURAL AVIATION ASSOCIATION,
WASHINGTON, DC:
2,612,235, REN. 2-23-12. INT. CL. 42.
- NATIONAL ANALYSTS WORLDWIDE, INC., PHILADEL-
PHIA, PA:
2,527,438, REN. 2-23-12. INT. CL. 42.
2,558,640, REN. 2-23-12. INT. CL. 42.
- NATIONAL ASSOCIATION FOR HEALTHCARE QUALITY,
INC., GLENVIEW, IL:
2,468,442, CANC. INT. CL. 42.
- NATIONAL ASSOCIATION OF PERSONAL FINANCIAL
ADVISORS, INC., ARLINGTON HEIGHTS, IL, DBA NAP-
FA:
4,117,711, PUB. 1-10-2012. INT. CL. 35.
- NATIONAL AUTOMATED CLEARING HOUSE ASSOCIA-
TION, HERNDON, VA:
4,119,527, INT. CL. 9.
- NATIONAL BIODIESEL BOARD, JEFFERSON CITY, MO:
4,116,635, PUB. 1-10-2012. U.S. CL. B.
- NATIONAL CHEMICAL LABORATORIES OF PA., INC.,
PHILADELPHIA, PA:
1,184,389, REN. 2-22-12. INT. CL. 3.
- NATIONAL CONSUMER TELECOM & UTILITIES EX-
CHANGE, NEW ORLEANS, LA:
4,117,597, PUB. 1-10-2012. INT. CL. 36.
- NATIONAL FAMILY PARTNERSHIP, MIAMI, FL:
4,117,054, PUB. 1-10-2012. INT. CL. 35.
- NATIONAL GLASS ASSOCIATION, MCLEAN, VA:
4,119,012, INT. CL. 41.
- NATIONAL HOT ROD ASSOCIATION (NHRA), GLEN-
DORA, CA:
2,467,583, CANC. INT. CL. 41.
- NATIONAL MODEL RAILROAD ASSOCIATION, INC.,
CHATTANOOGA, TN:
4,117,379, PUB. 1-10-2012. U.S. CL. 200.
- NATIONAL OILWELL VARCO, L.P., HOUSTON, TX:
1,176,876, REN. 2-21-12. INT. CL. 7.
- NATIONAL OILWELL VARCO, L.P., HOUSTON, TX, UNIT
CRANE & SHOVEL CORP., NEW BERLIN, WI:
1,183,497, REN. 2-22-12. INT. CL. 7.
- NATIONAL OPERATING COMMITTEE ON STANDARDS
FOR ATHLETIC EQUIPMENT, THE, OVERLAND PARK,
KS:
1,170,737, REN. 2-17-12. U.S. CL. A.
- NATIONAL PARK FOUNDATION, WASHINGTON, DC:
2,468,239, CANC. INT. CL. 42.
- NATIONAL PEDICULOSIS ASSOCIATION, INC., NEWTON,
MA:
2,643,230, REN. 2-17-12. INT. CL. 10.
- NATIONAL PRESTO INDUSTRIES, INC., EAU CLAIRE, WI:
4,117,260, PUB. 1-10-2012. INT. CL. 11.
- NATIONAL RAILROAD PASSENGER CORPORATION,
WASHINGTON, DC:
2,466,928, CANC. INT. CL. 39.
- NATIONAL SCIENCE TEACHERS ASSOCIATION, AR-
LINGTON, VA:
2,487,558, REN. 2-17-12. MULTIPLE CLASS, INT. CLS. 9
AND 16.
- NATIONAL SENIOR ASSOCIATES COMPANY, L.L.C.,
NORTH BRUNSWICK, NY:
2,967,957, CANC. INT. CL. 41.
- NATIONAL SLEEP FOUNDATION, ARLINGTON, VA:
4,117,649, PUB. 1-10-2012. INT. CL. 35.
- NATIONAL TOBACCO COMPANY, L.P., LOUISVILLE, KY:
4,117,820, PUB. 12-6-2011. INT. CL. 34.
4,118,850, INT. CL. 34.
- NATIONWIDE CHILDREN'S HOSPITAL, COLUMBUS, OH:
4,118,684, PUB. 1-10-2012. INT. CL. 44.
4,118,708, PUB. 1-10-2012. INT. CL. 44.
- NATIONWIDE PUBLISHING COMPANY, INC., LAKE HE-
LEN, FL:
2,912,421, CANC. INT. CL. 16.
- NATURAL EDGE HAWAII, INC., HONOLULU, HI:
4,118,592, PUB. 1-10-2012. INT. CL. 3.
- NATURE'S BEST, BREA, CA, HEALTH BEST DISTRIBU-
TORS, INC., SAN MARCOS, CA:
1,676,217, REN. 2-22-12. INT. CL. 42.
- NATURE'S SUNSHINE PRODUCTS, INC., PROVO, UT:
2,641,565, REN. 2-21-12. MULTIPLE CLASS, INT. CLS. 11
AND 35.
- NAVY FEDERAL CREDIT UNION, MERRIFIELD, VA:
2,522,415, REN. 2-21-12. INT. CL. 36.
- NBA DEVELOPMENT LEAGUE, LLC, SECAUCUS, NJ:
2,967,471, CANC. INT. CL. 16.
2,967,472, CANC. INT. CL. 18.
- NBA PROPERTIES, INC., NEW YORK, NY:
4,117,057, PUB. 1-10-2012. INT. CL. 41.
4,118,508, PUB. 1-10-2012. INT. CL. 18.
- NBC MESHTEC INC., JAPAN:
4,116,716, PUB. 1-10-2012. MULTIPLE CLASS, INT. CLS.
10, 11, 24 AND 25.
- NBC UNIVERSAL MEDIA, LLC, NEW YORK, NY:
1,672,127, REN. 2-23-12. INT. CL. 41.
- NBTA FOUNDATION, ALEXANDRIA, VA:
4,118,429, PUB. 1-10-2012. INT. CL. 41.
- NEBRASKA BOOK COMPANY, INC., LINCOLN, NE:
4,119,082, INT. CL. 42.
- NEBRASKA TRANSPORT COMPANY INC., GERING, NE:
4,117,700, PUB. 1-10-2012. INT. CL. 39.
- NEDBOY, ROBIN L., NEW YORK, NY:
4,117,615, PUB. 1-10-2012. INT. CL. 4.
4,117,686, PUB. 1-10-2012. INT. CL. 4.
- NEDERLANDSE ORGANISATIE VOOR TOEGEPAST- NAT-
UURWETENSCHAPPELIJK ONDERZOEK TNO, NETH-
ERLANDS:
4,116,686, PUB. 1-10-2012. MULTIPLE CLASS, INT. CLS. 9
AND 42.
- NEELD, KEN, CHARLOTTE, NC:
4,119,278, INT. CL. 20.
- NEENAH PAPER FR, LLC, ALPHARETTA, GA:
1,669,929, REN. 2-22-12. INT. CL. 16.
2,542,864, REN. 2-21-12. INT. CL. 16.
- NEENAN, MAURICE TIMOTHY, SANTA YNEZ, CA:
2,968,598, CANC. INT. CL. 30.
- NEFF, RICHARD D., SPRINGVILLE, NY:
2,707,550, CANC. INT. CL. 28.
- NEFF, SHAUN M., CAMARILLO, CA AND NEFF, JOE W.,
CAMARILLO, CA:
4,119,011, MULTIPLE CLASS, INT. CLS. 9, 14, 18 AND 28.
- NEILL-ROMINGER, BARBARA ELIZABETH, SANTEE, CA,
AKA NEILL, BARBARA ELIZABETH:
4,117,899, PUB. 1-10-2012. INT. CL. 3.
- NELLIE MAE CORPORATION, BRAINTREE, MA:
2,467,278, CANC. INT. CL. 36.
- NELSON, IRIS, WASHINGTON, DC:
2,622,584, REN. 2-21-12. INT. CL. 25.
- NENE NEST, LLC, WINDERMERE, FL:
4,119,263, INT. CL. 12.
- NEOGEN CORPORATION, LANSING, MI, AGRI-DIAG-
NOSTICS ASSOCIATES, CINNAMINSON, NJ:
1,671,511, REN. 2-22-12. INT. CL. 1.
- NEOPHARM, INC., LAKE FOREST, IL:
2,967,441, CANC. INT. CL. 5.
- NEPTUNE RESEARCH, INC., LAKE PARK, FL:
4,117,956, PUB. 1-10-2012. INT. CL. 8.
- NESTORE, ROBERT, MARLTON, NJ, DBA DCCS DAY-
CARE CLEANING SERVICES:
4,119,673, INT. CL. 37.
- NET COM DATA CORP. OF N.Y., SEA CLIFF, NY:
2,968,442, CANC. INT. CL. 9.
- NETERION, INC., CUPERTINO, CA:
2,968,556, CANC. INT. CL. 9.
2,968,572, CANC. INT. CL. 9.
- NETKIN, ROBERT S., MOUNTAIN VIEW, CA:
2,967,902, CANC. INT. CL. 16.
- NEUBERGER BERMAN GROUP LLC, NEW YORK, NY:
4,117,029, PUB. 1-10-2012. INT. CL. 36.
- NEUROLOGICA CORP., DANVERS, MA:
4,118,991, INT. CL. 10.

NEUTROGENA CORPORATION, LOS ANGELES, CA:
2,544,008. REN. 2-19-12. INT. CL. 5.

NEVERCENTER, CENTERVILLE, UT:
4,118,620. PUB. 1-10-2012. INT. CL. 9.

NEW BEVERAGE INSIGHTS JUICEWORKS, LLLP, ORLANDO, FL:
4,118,807. INT. CL. 32.

NEW FLYER INDUSTRIES ULC, WINNIPEG, MANITOBA, CANADA:
2,967,330. CANC. INT. CL. 12.

NEW FRONTIER MEDIA, INC., BOULDER, CO:
2,967,651. CANC. INT. CL. 38.
2,967,652. CANC. INT. CL. 38.
2,967,653. CANC. INT. CL. 38.

NEW LIFE SYMPHONY ORCHESTRA, ALLEN, TX:
4,118,255. PUB. 1-10-2012. INT. CL. 41.

NEW MEXICO EDUCATORS FEDERAL CREDIT UNION, ALBUQUERQUE, NM:
4,118,135. PUB. 1-10-2012. INT. CL. 36.
4,118,140. PUB. 1-10-2012. INT. CL. 36.

NEW PENN HOSPITALITY ASSOCIATES, LP, NEW HARTFORD, NY:
2,967,596. CANC. INT. CL. 43.

NEW WARRIOR MEDIA, LLC, HOUSTON, TX:
4,117,474. PUB. 1-10-2012. INT. CL. 41.

NEW WORLD YBS CO., LTD., SEOUL, REPUBLIC OF KOREA:
1,649,569. REN. 2-22-12. INT. CL. 26.

NEW YORK CITY WORLDWIDE MAGAZINE (R), NEW YORK, NY:
4,119,872. INT. CL. 16.

NEW YORK CONVENTION CENTER OPERATING CORPORATION, NEW YORK, NY:
4,117,908. PUB. 1-10-2012. MULTIPLE CLASS, INT. CLS. 36 AND 43.

NEW YORK LINK, INC., NEW YORK, NY:
4,117,906. PUB. 1-10-2012. INT. CL. 25.
4,117,919. PUB. 1-10-2012. INT. CL. 38.

NEW YORK STATE RESTAURANT ASSOCIATION EDUCATIONAL FOUNDATION, ALBANY, NY:
4,118,143. PUB. 1-10-2012. INT. CL. 41.

NEW YORK TIMES COMPANY, THE, NEW YORK, NY:
1,149,780. CANC. INT. CL. 16.
2,578,082. REN. 2-23-12. MULTIPLE CLASS, INT. CLS. 16 AND 42.

NEWELL OPERATING COMPANY, ATLANTA, GA:
4,118,858. INT. CL. 6.

NEXANS, FRANCE:
4,116,869. PUB. 1-10-2012. INT. CL. 9.

NEXEN TIRE CORPORATION, KYONGSANGNAM-DO, REPUBLIC OF KOREA:
4,119,434. INT. CL. 12.

NEXSAN TECHNOLOGIES, THOUSAND OAKS, CA:
4,119,264. INT. CL. 9.

NEXTBIO, CUPERTINO, CA:
4,118,784. INT. CL. 42.

NEXTMEDIA OPERATING, INC., GREENWOOD VILLAGE, CO:
4,119,719. INT. CL. 9.

NEXTRUSION GMBH, 86399 BOBINGEN, FED REP GERMANY:
4,116,737. PUB. 1-10-2012. MULTIPLE CLASS, INT. CLS. 17, 23 AND 24.

NEXUS ENERGYHOMES, INC., ANNAPOLIS, MD:
4,117,068. PUB. 1-10-2012. INT. CL. 37.

NFI INDUSTRIES, INC., VINELAND, NJ:
4,118,902. MULTIPLE CLASS, INT. CLS. 35, 36, 37 AND 39.

NGL ENERGY PARTNERS LP, TULSA, OK:
4,119,647. MULTIPLE CLASS, INT. CLS. 4 AND 39.

NGUYEN, THANH D, FOUNTAIN VALLEY, CA:
4,117,265. PUB. 1-10-2012. MULTIPLE CLASS, INT. CLS. 35, 36, 41 AND 42.

NHS, INC., SANTA CRUZ, CA:
4,116,669. PUB. 1-10-2012. MULTIPLE CLASS, INT. CLS. 16 AND 25.

NICE BOWTIE, LLC, PORTLAND, OR:
4,118,199. PUB. 1-10-2012. MULTIPLE CLASS, INT. CLS. 25 AND 43.

NICHOLAS OPARA, PHOENIX, AZ:
4,116,901. PUB. 1-10-2012. INT. CL. 42.

NICKLAUS COMPANIES, LLC, NORTH PALM BEACH, FL:
2,522,676. REN. 2-22-12. MULTIPLE CLASS, INT. CLS. 35, 37, 41 AND 42.

NIELSEN, JOHN M, SAN FRANCISCO, CA:
4,119,424. INT. CL. 36.

NIGHT INCUBATOR LLC, NEW YORK, NY:
4,118,125. PUB. 1-10-2012. INT. CL. 42.

NIITEK INC., DULLES, VA:
4,118,829. INT. CL. 37.

NIKON CORPORATION, TOKYO, JAPAN:
4,119,545. INT. CL. 9.

NINJAI GANG, LLC, KAILUA, HI:
4,118,859. INT. CL. 25.

NINTENDO OF AMERICA INC., REDMOND, WA:
4,119,478. INT. CL. 9.

NIPPON DENKI KABUSHIKI KAISHA, TOKYO, JAPAN, DBA NEC CORPORATION:
2,967,606. CANC. INT. CL. 9.

NITE BEAM PRODUCTS, LLC, CHARLOTTE, NC:
4,119,286. INT. CL. 25.

NIX, CLYDE, SNELLVILLE, GA:
4,116,899. PUB. 1-10-2012. INT. CL. 37.

NIXON, INC., ENCINITAS, CA:
4,118,830. INT. CL. 9.

NKK SWITCHES OF AMERICA, INC., SCOTTSDALE, AZ:
1,695,840. REN. 2-19-12. INT. CL. 9.

NOBLE BEAUTY OF AMERICA, INC., TORRANCE, CA:
4,118,005. PUB. 1-10-2012. INT. CL. 26.

NOBLE BUTTERFLY, LAS VEGAS, NV:
4,116,668. PUB. 1-10-2012. INT. CL. 25.

NOEVEEN CORDBACHE, SACRAMENTO, CA, DBA KNOCKOUT STAR:
4,118,651. PUB. 1-10-2012. INT. CL. 25.

NOMACORC, LLC, ZEBULON, NC:
4,119,666. INT. CL. 20.

NOMADICS, INC., STILLWATER, OK:
4,116,952. PUB. 1-10-2012. INT. CL. 9.

NOMIKI GLYNATSISS COUTURE PTY LTD, KENMORE QLD, AUSTRALIA:
4,117,072. PUB. 1-10-2012. MULTIPLE CLASS, INT. CLS. 14 AND 25.

NOODLEMAN, F. RICHARD, CAMPBELL, CA:
2,530,682. REN. 2-22-12. INT. CL. 3.

NOPALEA, INC., PHOENIX, AZ:
2,524,948. REN. 2-21-12. INT. CL. 16.

NORBROOK LABORATORIES LIMITED, NEWRY, COUNTY DOWN, NORTHERN IRELAND:
4,119,160. INT. CL. 5.

NORCOM INCORPORATED, GRIFFIN, GA:
2,967,635. CANC. INT. CL. 16.

NORCYN, INC., FORT WAYNE, IN:
2,968,382. CANC. INT. CL. 28.

NORMA MICHIGAN, INC., AUBURN HILLS, MI:
2,524,993. REN. 2-21-12. INT. CL. 12.

NORTH AMERICA CORP., EDISON, NJ:
2,425,661. CANC. INT. CL. 28.

NORTH AMERICAN FUNDING CORPORATION, DEERFIELD, IL:
2,467,660. CANC. INT. CL. 36.

NORTHWEST OPEN ACCESS NETWORK, TACOMA, WA:
4,117,532. PUB. 1-10-2012. INT. CL. 38.

NOSY CROW LIMITED, LONDON, UNITED KINGDOM:
4,119,039. INT. CL. 9.

NOURISHE LLC, DELRAY BEACH, FL:
4,116,961. PUB. 1-10-2012. INT. CL. 3.

NOVALIS HOLDINGS LIMITED, WAN CHAI, HONG KONG:
2,662,826. REN. 2-21-12. INT. CL. 27.

NOVARTIS AG, BASEL, SWITZERLAND:
2,538,370. REN. 2-21-12. INT. CL. 5.

NOVATORQUE, INC., SUNNYVALE, CA:
4,118,885. INT. CL. 12.

NOVELAS EDUCATIVAS, LLC, BURBANK, CA:
4,116,592. PUB. 1-10-2012. INT. CL. 41.

- NOVEX NOVICE TO EXPERT LEARNING, LLC, ST. LOUIS, MO:
4,119,656, INT. CL. 42.
- NOVO NORDISK HEALTH CARE AG, SWITZERLAND:
4,116,870, PUB. 1-10-2012. INT. CL. 5.
4,116,871, PUB. 1-10-2012. INT. CL. 5.
- NOVUS MEDIA, INC., PLYMOUTH, MN:
4,117,416, PUB. 1-10-2012. INT. CL. 35.
- NOWACCOUNT NETWORK CORPORATION, ATLANTA, GA:
4,118,345, PUB. 1-10-2012. MULTIPLE CLASS, INT. CLS. 36 AND 42.
4,118,347, PUB. 1-10-2012. MULTIPLE CLASS, INT. CLS. 36 AND 42.
- NP IP HOLDINGS LLC, LAS VEGAS, NV:
4,118,395, PUB. 1-10-2012. INT. CL. 41.
4,118,397, PUB. 1-10-2012. INT. CL. 43.
- NPSL, INC., WILMINGTON, DE:
4,117,452, PUB. 1-10-2012. INT. CL. 35.
- NRGNOVATIONS, LLC, SKANEATELES, NY:
4,119,882, INT. CL. 5.
- NSTEIN TECHNOLOGIES INC., LAVAL (QUEBEC), CANADA:
2,965,473, CANC. INT. CL. 9.
- NTN BUZZTIME, INC., CARLSBAD, CA:
4,117,810, PUB. 1-10-2012. INT. CL. 41.
- NUART, INC., NORTH MANKATO, MN:
2,467,271, CANC. INT. CL. 42.
- NUCARA LLC, CONRAD, IA, JOHNSRUD, T.J., NEVADA, IA:
2,649,753, REN. 2-22-12. MULTIPLE CLASS, INT. CLS. 5 AND 35.
- NUESTRA ESCUELA, INC., CAGUAS, PUERTO RICO:
4,117,439, PUB. 1-10-2012. INT. CL. 41.
- NUNES COMPANY, INC., THE, SALINAS, CA:
4,117,560, PUB. 1-10-2012. MULTIPLE CLASS, INT. CLS. 25 AND 31.
- NUNHEMS B.V., 6083 AQC, NUNHEM, NETHERLANDS:
2,966,194, CANC. MULTIPLE CLASS, INT. CLS. 31, 35 AND 44.
- NUPUR FOLK DANCE ACADEMY, SAN JOSE, CA:
2,968,337, CANC. INT. CL. 41.
- NURSERYSOURCE, WOOD VILLAGE, OR:
4,117,343, PUB. 1-10-2012. MULTIPLE CLASS, INT. CLS. 21 AND 22.
- NUSSER, TIMOTHY J., PENSACOLA, FL:
2,458,844, CANC. INT. CL. 42.
- NUTRICITY.COM, LLC, SCOTTSDALE, AZ:
4,118,604, PUB. 1-10-2012. INT. CL. 35.
- NUTRICORE NORTHEAST, INC., YORK, PA:
2,967,885, CANC. INT. CL. 42.
- NUVIM, INC., PARAMUS, NJ:
3,042,100, CANC. INT. CL. 32.
- NV BEKAERT SA, ZWEVEGEM, BELGIUM:
2,466,911, CANC. INT. CL. 11.
- NYDREE FLOORING LLC, FOREST, VA:
4,118,337, PUB. 1-10-2012. INT. CL. 19.
- NYKO TECHNOLOGIES, INC., LOS ANGELES, CA:
4,118,871, INT. CL. 9.
- O OLIVE OIL, INC., PETALUMA, CA:
2,968,449, CANC. INT. CL. 30.
- O. A. CARGO INC., WESTMINSTER, CA:
4,118,181, PUB. 1-10-2012. INT. CL. 39.
- O.P.E.N. AMERICA, INC., PHOENIX, AZ:
2,467,713, CANC. INT. CL. 37.
- O'NEILL, MARGARET A., VILLANOVA, PA:
2,968,526, CANC. MULTIPLE CLASS, INT. CLS. 9, 16 AND 41.
- OAKWOOD SOLUTIONS, LLC, APPLETON, WI, DBA THE CONOVER COMPANY:
4,117,225, PUB. 1-10-2012. MULTIPLE CLASS, INT. CLS. 9 AND 42.
- OBCHTCHESTVO S OGRANITCHENNOI OTVETSTVENNOSTYOU "TCHERNOV AODIO", RUSSIAN FED.:
4,116,809, PUB. 1-10-2012. MULTIPLE CLASS, INT. CLS. 6, 9 AND 35.
- OBS FINANCIAL SERVICES, INC., WHITEHOUSE, OH:
4,118,652, PUB. 1-10-2012. INT. CL. 36.
- OBSCHESTVO S OGRANICHENNOI OTVETSTVENNOSTIU "GLAVSPIRTTREST", MOSCOW REGION, RUSSIAN FED.:
4,116,634, PUB. 1-10-2012. INT. CL. 33.
- OBSCHESTVO S OGRANICHENNOI OTVETSTVENNOSTIU "GLAVSPIRTTREST", MOSCOW REGION, PUSHKINO, RUSSIAN FED.:
4,116,646, PUB. 1-10-2012. INT. CL. 33.
- OBSCHESTVO S OGRANICHENNOI OTVETSTVENNOSTYU "CELISTIC", RUSSIAN FED.:
4,116,795, PUB. 1-10-2012. MULTIPLE CLASS, INT. CLS. 16, 28 AND 41.
- OBSCHESTVO S OGRANICHENNOY OTVETSTVENNOSTYU "SHUSHENSKAYA MARKA", KRASNOYARSKY KRAI, RUSSIAN FED.:
4,116,830, PUB. 1-10-2012. INT. CL. 33.
- OBSCHESTVO S OGRANICHENNOY OTVETSTVENNOSTYU "ASTROFARMA", RUSSIAN FED.:
4,116,773, PUB. 1-10-2012. MULTIPLE CLASS, INT. CLS. 3 AND 5.
- OC RAW DOG, LLC, MISSION VIEJO, CA:
4,117,450, PUB. 1-10-2012. INT. CL. 31.
- OCCUNOMIX INTERNATIONAL LLC, PORT JEFFERSON STATION, NY:
4,118,115, PUB. 1-10-2012. INT. CL. 25.
4,118,339, PUB. 1-10-2012. INT. CL. 25.
- OCEAN CROWN PRODUCTS, INC., ANAHEIM, CA:
2,528,385, REN. 2-22-12. INT. CL. 29.
- OCEAN GARDEN PRODUCTS, INC., SAN DIEGO, CA:
2,528,476, REN. 2-22-12. INT. CL. 29.
- OCEAN ORGANICS, INC., ANN ARBOR, MI:
4,119,528, INT. CL. 1.
- OCZ TECHNOLOGY GROUP, INC., SAN JOSE, CA:
4,119,820, INT. CL. 9.
- ODINTSOVO CONFECTIONERY PLANT, LTD., RUSSIAN FED.:
4,116,785, PUB. 1-10-2012. MULTIPLE CLASS, INT. CLS. 29, 30 AND 35.
- OE, INC., GARBERVILLE, CA:
4,118,037, PUB. 1-10-2012. INT. CL. 25.
- OEG-TEG, LLC, GILBERT, AZ:
2,967,426, CANC. INT. CL. 7.
- OENOFOROS AB, SWEDEN:
4,116,714, PUB. 1-10-2012. INT. CL. 33.
- OG SACK, LLC, BOULDER, CO:
4,117,410, PUB. 1-10-2012. INT. CL. 22.
- OHEL CHILDREN'S HOME AND FAMILY SERVICES, INC., BROOKLYN, NY:
4,118,961, MULTIPLE CLASS, INT. CLS. 36, 41 AND 45.
- OHIO CATTLEMEN'S ASSOCIATION, INC., MARYSVILLE, OH:
2,558,324, REN. 2-22-12. U.S. CL. 200.
- OKI ELECTRIC INDUSTRY CO., LTD., TOKYO, JAPAN:
4,116,608, PUB. 1-10-2012. MULTIPLE CLASS, INT. CLS. 36, 39, 41, 43 AND 44.
- OKSEBRA RUNNING AB, SWEDEN:
4,116,805, PUB. 1-10-2012. INT. CL. 25.
- OKUTANI CORPORATION, ELK GROVE VILLAGE, IL, DBA HOLLYWOOD MIRROR:
4,117,760, PUB. 1-10-2012. INT. CL. 35.
- OLD BAY COMPANY, LLC, SPARKS, MD, OLD BAY COMPANY, INC., HUNT VALLEY, MD:
1,671,279, REN. 2-23-12. INT. CL. 30.
- OLD PEOPLE'S RIDING CLUB, LOTHIAN, MD:
2,642,111, REN. 2-21-12. INT. CL. 41.
- OLSON ALUMINUM CASTING, LTD, ROCKFORD, IL:
4,117,795, PUB. 1-10-2012. INT. CL. 40.
- OLSON COMMUNICATIONS INC., CHICAGO, IL:
4,117,504, PUB. 1-10-2012. INT. CL. 35.
- OLYMPUS CORPORATION, TOKYO, JAPAN:
4,117,388, PUB. 1-10-2012. INT. CL. 9.
- OM SOLAR ASSOCIATION CO., LTD., HAMAMATSU-SHI, SHIZUOKA, JAPAN:
2,967,327, CANC. MULTIPLE CLASS, INT. CLS. 16, 19, 41 AND 42.
- OMAR KASSEM ALESAYI MARKETING CO. LTD., JEDDAH 21492, SAUDI ARABIA:
2,966,168, CANC. MULTIPLE CLASS, INT. CLS. 29, 30, 31

AND 32.
 OMIIDYAR NETWORK COMMONS, LLC, REDWOOD CITY, CA:
 4,118,795, MULTIPLE CLASS, INT. CLS. 35, 36, 41 AND 45.
 4,119,060, MULTIPLE CLASS, INT. CLS. 35, 36, 41 AND 45.
 OMNI SURGICAL, LLC, AUSTIN, TX, DBA SPINE360:
 4,118,098, PUB. 1-10-2012. INT. CL. 10.
 4,118,099, PUB. 1-10-2012. INT. CL. 10.
 4,118,101, PUB. 1-10-2012. INT. CL. 10.
 OMS INVESTMENTS, INC., SANTA MONICA, CA:
 2,967,755, CANC. INT. CL. 5.
 ONAKWEST, LLC, SAINT AUGUSTINE, FL:
 4,118,371, PUB. 1-10-2012. INT. CL. 25.
 4,118,372, PUB. 1-10-2012. INT. CL. 16.
 ONCOLOGY REHAB PARTNERS, LLC, NORTHBORO, MA:
 4,118,992, U.S. CL. B.
 ONE LEGGED DUCK PTY LTD, GLENUNGA, SOUTH AUSTRALIA, AUSTRALIA:
 2,968,321, CANC. INT. CL. 33.
 ONLINE TRIP INSURANCE SERVICES, INC., MONTE SERENO, CA:
 4,117,613, PUB. 1-10-2012. MULTIPLE CLASS, INT. CLS. 35, 36 AND 39.
 ONSIGHT SOLUTIONS INTERNATIONAL, LLC, ALBANY, NY:
 4,117,607, PUB. 1-10-2012. INT. CL. 35.
 OOIBIT INC., MISSION VIEJO, CA:
 4,117,142, PUB. 1-10-2012. INT. CL. 21.
 OPERATION RAINBOW, INC., OAKLAND, CA:
 4,118,279, PUB. 1-10-2012. INT. CL. 44.
 OPICI IMPORT CO. INC., GLEN ROCK, NJ:
 4,118,494, PUB. 1-10-2012. INT. CL. 33.
 OPSEC SECURITY GROUP, INC., DENVER, CO:
 2,559,914, REN. 2-17-12. INT. CL. 42.
 OPTERRA ENERGY GROUP, INC., WESTMINSTER, CO:
 4,119,101, INT. CL. 35.
 OPTIMA, INC., STRATFORD, CT:
 2,579,703, REN. 2-17-12. INT. CL. 9.
 OPTIONS & CHOICES, INC., GREENWOOD VILLAGE, CO:
 4,119,137, INT. CL. 42.
 ORACLE INTERNATIONAL CORPORATION, REDWOOD CITY, CA:
 1,200,239, REN. 2-23-12. MULTIPLE CLASS, INT. CLS. 9 AND 16.
 2,968,517, CANC. INT. CL. 9.
 ORAFOL EUROPE GMBH, ORANIENBURG, FED REP GERMANY:
 2,551,871, REN. 2-17-12. MULTIPLE CLASS, INT. CLS. 16 AND 17.
 ORAL HEALTH PRODUCTS, INC., TULSA, OK:
 2,636,756, REN. 2-21-12. INT. CL. 21.
 ORANGE PRODUCTS, INC., ALLENTOWN, PA:
 4,117,411, PUB. 1-10-2012. MULTIPLE CLASS, INT. CLS. 17 AND 28.
 ORATEC INTERVENTIONS, INC., MEMPHIS, TN:
 2,553,245, REN. 2-21-12. INT. CL. 10.
 ORCA MD LLC, PARK CITY, UT:
 4,119,289, INT. CL. 9.
 ORECK HOLDINGS, LLC, CHEYENNE, WY:
 2,467,158, CANC. INT. CL. 1.
 OREGON CHERRY GROWERS, INC., SALEM, OR:
 4,119,313, INT. CL. 29.
 ORG, USA, INC., BUDD LAKE, NJ, DBA MAISPACE:
 4,119,031, INT. CL. 20.
 ORGANIC HEALTH LABS, LLC, HOLLYWOOD, FL:
 4,116,659, PUB. 1-10-2012. INT. CL. 5.
 ORGATERM PRODUKTIONS- UND WARENVERTRIEBS-GESELLSCHAFT MBH, 59349 LUDINGHAUSEN, FED REP GERMANY:
 2,467,049, CANC. INT. CL. 10.
 ORICA AUSTRALIA PTY LTD, VICTORIA 3000, AUSTRALIA:
 2,518,960, REN. 2-17-12. INT. CL. 40.
 ORICA AUSTRALIA PTY LTD, MELBOURNE, VICTORIA, 3000, AUSTRALIA:
 2,518,990, REN. 2-17-12. INT. CL. 1.
 2,518,992, REN. 2-17-12. INT. CL. 9.
 ORICA AUSTRALIA PTY LTD, VICTORIA, 3000, AUSTRALIA:
 2,521,474, REN. 2-17-12. INT. CL. 13.
 ORICA AUSTRALIA PTY LTD, MELBORNE, VICTORIA 3000, AUSTRALIA:
 2,523,794, REN. 2-22-12. INT. CL. 37.
 ORICA AUSTRALIA PTY LTD, VICTORIA 3000, AUSTRALIA:
 2,523,795, REN. 2-22-12. INT. CL. 9.
 ORIENTAL TRADING COMPANY, INC., OMAHA, NE:
 2,543,046, REN. 2-22-12. INT. CL. 35.
 ORIGIN ACTIVE LIFESTYLE COMMUNITIES INC., NORTH YORK, ONTARIO, CANADA:
 4,116,656, PUB. 1-10-2012. MULTIPLE CLASS, INT. CLS. 41 AND 43.
 ORIGINS NATURAL RESOURCES INC., NEW YORK, NY, ORIGINS NATURAL RESOURCES INC., NEW YORK, NY:
 1,675,526, REN. 2-23-12. INT. CL. 3.
 ORION ALLIED SERVICES LLC, HENDERSON, TN:
 4,117,662, PUB. 1-10-2012. MULTIPLE CLASS, INT. CLS. 35 AND 44.
 4,117,663, PUB. 1-10-2012. MULTIPLE CLASS, INT. CLS. 35 AND 44.
 ORION DIAGNOSTICA OY, FINLAND:
 2,967,228.
 ORION ENTERPRISES, INC., FREDERICKSBURG, VA:
 2,543,070, REN. 2-22-12. INT. CL. 35.
 ORLANDO BAKING COMPANY, INC., CLEVELAND, OH:
 4,118,244, PUB. 1-10-2012. INT. CL. 30.
 4,118,297, PUB. 1-10-2012. INT. CL. 30.
 ORTHO ORGANIZERS, INC., CARLSBAD, CA:
 2,663,121, REN. 2-21-12. INT. CL. 10.
 ORTHODYNAMICS INTERNATIONAL LLC, CROTON ON HUDSON, NY:
 4,119,437, INT. CL. 41.
 ORTIZ, JESUS A., SAN JOSE, CA:
 2,468,465, CANC. INT. CL. 9.
 OSPREY PACKS, INC., CORTEZ, CO:
 2,571,330, REN. 2-21-12. INT. CL. 18.
 4,119,126, INT. CL. 18.
 OSRAM SYLVANIA INC., DANVERS, MA:
 2,967,479, CANC. MULTIPLE CLASS, INT. CLS. 35, 37 AND 42.
 OSTHOFF MANAGEMENT CORP., ELKHART LAKE, WI:
 4,118,054, PUB. 1-10-2012. INT. CL. 43.
 4,118,055, PUB. 1-10-2012. INT. CL. 43.
 4,118,061, PUB. 1-10-2012. INT. CL. 43.
 4,118,068, PUB. 1-10-2012. INT. CL. 41.
 OTICON A/S, SMOERUM, DENMARK:
 2,467,141, CANC. INT. CL. 10.
 OTIS SPUNKMEYER, LLC, SAN LEANDRO, CA, PENNANT FOODS COMPANY, ITASCA, IL:
 2,540,932, REN. 2-23-12. INT. CL. 30.
 OTM PARTNERS LLC, ARLINGTON, VA:
 4,116,575, PUB. 1-10-2012. INT. CL. 35.
 OTOVATION, LLC, KING OF PRUSSIA, PA:
 4,119,017, INT. CL. 9.
 OTTER PRODUCTS, LLC, FORT COLLINS, CO:
 4,116,998, PUB. 1-10-2012. INT. CL. 36.
 OTTO BOCK HEALTHCARE GMBH, 37115 DUDERSTADT, FED REP GERMANY:
 1,717,835, REN. 2-21-12. INT. CL. 10.
 OUICHE LORRAINE, LA GARENNE-COLOMBES, FRANCE:
 4,117,431, PUB. 1-10-2012. INT. CL. 35.
 OUR COUNTRY DESERVES BETTER PAC, SACRAMENTO, CA:
 4,118,273, PUB. 1-10-2012. INT. CL. 35.
 OUTSTANDING OCCASIONS, L.L.C., PHOENIX, AZ:
 4,117,681, PUB. 1-10-2012. INT. CL. 41.
 OVANA CORPORATION, RIVERVIEW, MI, AKA OVANA YOGA SCULPTURES & JEWELRY:
 2,868,919, CANC. INT. CL. 14.

- OVD KINEGRAM AG, SWITZERLAND:
4,116,683, PUB. 1-10-2012. MULTIPLE CLASS, INT. CLS. 6, 9, 16 AND 20.
- OXFORD INDUSTRIES, INC., ATLANTA, GA:
2,968,666, CANC. INT. CL. 25.
- OZONE COMMUNITY CORPORATION, JAPAN:
4,116,757, PUB. 1-10-2012. MULTIPLE CLASS, INT. CLS. 9, 14, 16, 18, 20, 21, 24, 25, 26, 28 AND 34.
- P.Y.A. IMPORTER LTD., TORONTO, ONTARIO, CANADA:
4,116,985, PUB. 1-10-2012. INT. CL. 25.
- P&B (FOODS) LIMITED, WEST YORKSHIRE, UNITED KINGDOM:
4,117,814, PUB. 1-10-2012. MULTIPLE CLASS, INT. CLS. 29 AND 30.
- PABLO BIGIO, SUMMIT, NJ:
4,117,696, PUB. 1-10-2012. INT. CL. 25.
- PACIFIC COAST BUILDING PRODUCTS, INC., RANCHO CORDOVA, CA. DBA PABCO GYPSUM:
1,676,794. REN. 2-23-12. INT. CL. 19.
- PACIFIC COAST OPERA, A CALIFORNIA NON-PROFIT PUBLIC BENEFIT CORPORATION, LONG BEACH, CA:
4,118,092, PUB. 1-10-2012. INT. CL. 41.
- PACIFIC FERMENTATION INDUSTRIES LTD, LANGLEY, BC, CANADA:
4,116,979, PUB. 1-10-2012. MULTIPLE CLASS, INT. CLS. 30 AND 35.
- PACIFIC HOME GMBH, SWITZERLAND:
4,116,740, PUB. 1-10-2012. MULTIPLE CLASS, INT. CLS. 18 AND 25.
- PACIFIC LIFE INSURANCE COMPANY, NEWPORT BEACH, CA:
2,968,800, CANC. INT. CL. 25.
- PACIFIC NORTHWEST FARMERS COOPERATIVE, INC., GENESEE, ID:
4,117,386, PUB. 1-10-2012. INT. CL. 29.
- PACIFIC REPUBLIC, INC., PITTSBURG, CA:
4,118,528, PUB. 1-10-2012. INT. CL. 30.
4,118,664, PUB. 1-10-2012. INT. CL. 43.
- PACIFIC SPORTS GROUP, LLC, OCEANSIDE, CA:
2,968,123, CANC. INT. CL. 28.
- PACIFIC STAIR CORPORATION, SALEM, OR:
4,119,110, INT. CL. 19.
- PACIFIC SUNWEAR OF CALIFORNIA, INC., ANAHEIM, CA:
4,119,416, INT. CL. 3.
4,119,417, MULTIPLE CLASS, INT. CLS. 18 AND 25.
4,119,418, INT. CL. 25.
4,119,419, INT. CL. 25.
4,119,420, MULTIPLE CLASS, INT. CLS. 25 AND 35.
4,119,421, MULTIPLE CLASS, INT. CLS. 25 AND 35.
4,119,422, INT. CL. 14.
- PACIFIC VIAL MFG. INC., CITY OF COMMERCE, CA:
4,117,803, PUB. 1-10-2012. INT. CL. 40.
- PACIFIC VIBRATIONS LLC, CARLSBAD, CA:
4,118,253, PUB. 1-10-2012. INT. CL. 25.
4,118,292, PUB. 1-10-2012. INT. CL. 16.
- PACIFICA WEALTH ADVISORS, INC., MISSION VIEJO, CA:
4,119,862, INT. CL. 36.
- PACIFICDENTAL BENEFITS, INC., CONCORD, CA:
2,968,386, CANC. INT. CL. 44.
2,968,387, CANC. INT. CL. 44.
- PACTIV LLC, LAKE FOREST, IL, EKCO PRODUCTS, INC., WHEELING, IL:
925,771. REN. 2-21-12. U.S. CL. 13 (INT. CL. 21).
- PADS 2 HOME REALTY CORPORATION, BETHEL, CT:
4,118,238, PUB. 1-10-2012. INT. CL. 36.
- PAGE ONE VENTURES, LTD., VANCOUVER, CANADA:
4,117,286, PUB. 1-10-2012. INT. CL. 38.
- PAGON, GARRETT D., CHANTILLY, VA AND BALKISOON, OMAR, CHANTILLY, VA:
4,117,995, PUB. 1-10-2012. INT. CL. 35.
- PAKSENSE, INC., BOISE, ID:
4,119,596, INT. CL. 9.
- PALADIN BRANDS GROUP, INC., CEDAR RAPIDS, IA:
1,670,976. REN. 2-23-12. INT. CL. 7.
- PALADINO CONSTRUCTION, LLC, BRONX, NY:
1,190,942. REN. 2-22-12. INT. CL. 37.
- PALM HARBOR HOMES, INC., PHOENIX, AZ, DBA NATIONWIDE HOMES:
4,119,870, MULTIPLE CLASS, INT. CLS. 19 AND 37.
- PALMUCCI, ANTHONY, PINE BEACH, NJ:
2,468,450, CANC. INT. CL. 41.
- PAN AMERICAN GRAIN MFG. CO., INC., GUAYNABO, PUERTO RICO:
4,117,486, PUB. 1-10-2012. INT. CL. 30.
- PANCHAL ASSOCIATES LLP, NEW YORK, NY:
4,117,432, PUB. 1-10-2012. INT. CL. 45.
- PANDORA JEWELRY, LLC, COLUMBIA, MD:
4,118,900, INT. CL. 35.
- PANOVA GROUP LLP, WASHINGTON, DC:
4,116,978, PUB. 1-10-2012. MULTIPLE CLASS, INT. CLS. 35 AND 45.
- PAP THE QUESTION, LLC, NEW YORK, NY:
4,117,777, PUB. 1-10-2012. INT. CL. 41.
- PAPALOIZOS PUBLICATIONS INC., SILVER SPRING, MD:
4,117,787, PUB. 1-10-2012. MULTIPLE CLASS, INT. CLS. 9, 16 AND 42.
- PARAGON SCIENTIFIC INCORPORATED, WOBURN, MA:
2,968,305, CANC. INT. CL. 9.
- PARALAN CORPORATION, SAN DIEGO, CA:
1,672,424. REN. 2-22-12. INT. CL. 9.
- PARAMOUNT FITNESS CORP., LOS ANGELES, CA:
2,468,528, CANC. INT. CL. 28.
- PARAMOUNT TECHNOLOGY GROUP, INC, CHESAPEAKE, VA:
2,935,243, CANC. INT. CL. 42.
- PARK AVENUE COLLECTION, LLC, NEW YORK, NY:
4,117,429, PUB. 1-10-2012. INT. CL. 35.
- PARK, EUN-KYUNG, SEOUL, REPUBLIC OF KOREA, DBA COMPANY THRU:
2,968,200, CANC. INT. CL. 25.
- PARKEON, FRANCE:
4,116,797, PUB. 1-10-2012. INT. CL. 9.
- PARKER INTANGIBLES LLC, CLEVELAND, OH, DAYCO CORPORATION, DAYTON, OH:
724,510. REN. 2-21-12. U.S. CL. 35 (INT. CL. 17).
- PARKER RANCH, INC., KAMUELA, HI:
4,117,591, PUB. 1-10-2012. INT. CL. 44.
- PARKER, PATRICIA, SAN DIEGO, CA:
4,118,224, PUB. 1-10-2012. INT. CL. 16.
- PARKSBYNATURE NETWORK, LLC, NEW YORK, NY:
4,118,711, PUB. 1-10-2012. INT. CL. 9.
- PARMALAT CANADA INC., ETOBICOKE, CANADA:
4,118,903, INT. CL. 29.
- PARRISH ENTERPRISES, LTD., ENID, OK:
4,118,730, PUB. 1-10-2012. INT. CL. 6.
- PART SOLUTIONS, LLC, MILFORD, OH:
2,537,378. REN. 2-22-12. INT. CL. 9.
- PARTICLE SCIENCES, INC., BETHLEHEM, PA:
4,119,638, INT. CL. 42.
- PARTNERS FOR DEMOCRATIC CHANGE, WASHINGTON, DC:
4,117,181, PUB. 1-10-2012. INT. CL. 35.
4,117,195, PUB. 1-10-2012. INT. CL. 35.
- PARTNERSHIP FOR A DRUG FREE AMERICA, INC., NEW YORK, NY:
4,119,166, MULTIPLE CLASS, INT. CLS. 9, 16, 35, 41 AND 44.
- PASABAN, S.A., SPAIN:
4,116,819, PUB. 1-10-2012. MULTIPLE CLASS, INT. CLS. 7 AND 37.
- PASTOR, JOSE, TIBURON, CA:
4,118,286, PUB. 1-10-2012. INT. CL. 35.
- PATCH PRODUCTS, INC., BELOIT, WI:
4,119,159, INT. CL. 28.
4,119,209, INT. CL. 28.
- PATERNO IMPORTS, LTD., LAKE BLUFF, IL, DBA TERLATO WINES INTERNATIONAL:
4,119,081, INT. CL. 33.
- PATHWAY TO WISDOM, LLC, STOW, OH:
4,119,690, INT. CL. 41.
- PATIENTKEEPER, INC., WALTHAM, MA:
2,567,019. REN. 2-22-12. INT. CL. 9.
- PATIO ENCLOSURES, INC., MACEDONIA, OH:
2,968,303, CANC. INT. CL. 19.

PATRICK D. BRIESE, DDS, LLC, RAYNE, LA:
4,118,554, PUB. 1-10-2012. INT. CL. 44.

PATRIOT GUARD RIDERS, INC., TULSA, OK:
4,117,799, PUB. 1-10-2012. MULTIPLE CLASS, INT. CLS.
14, 36 AND 45.

PATRIOT SALES, INC., PACIFIC, MO:
2,968,341, CANC. INT. CL. 13.

PATRIOTIC PRODUCTIONS, LLC, OMAHA, NE:
4,119,583, INT. CL. 41.

PATSY'S BRAND, INC., NEW YORK, NY:
4,118,332, PUB. 1-10-2012. INT. CL. 43.

PAUL MORELLI HOLDINGS, LLC, NEW HOPE, PA:
2,541,868, REN. 2-21-12. INT. CL. 14.
2,541,868, CANC. MULTIPLE CLASS, INT. CLS. 35 AND
40.

PAUL REVERE VARIABLE ANNUITY INSURANCE COM-
PANY, THE, CHATTANOOGA, TN:
1,194,852, REN. 2-17-12. INT. CL. 36.

PAWS WITH A CAUSE, WAYLAND, MI:
4,117,405, PUB. 1-10-2012. MULTIPLE CLASS, INT. CLS.
41 AND 44.

PAY-E, INC., FRESNO, CA:
2,481,617, REN. 2-17-12. INT. CL. 9.

PAYAL KEDIA, NEW YORK, NY, DBA ALLIA INC:
4,118,969, INT. CL. 14.

PAYDIVVY, INC., IRVINE, CA:
4,119,432, MULTIPLE CLASS, INT. CLS. 35 AND 36.

PBN MEDICALS DENMARK A/S, 3660 STENLOSE, DEN-
MARK:
2,467,003, CANC. INT. CL. 1.

PCPI PRECISION CUSTOM PRODUCTS, INC., DE GRAFF,
OH:
2,524,056, REN. 2-22-12. INT. CL. 40.

PCT INTERNATIONAL, INC., MESA, AZ:
4,118,782, INT. CL. 9.

PDB ENTERPRISES, INC., LITTLE ROCK, AZ:
2,779,561, CANC. INT. CL. 35.

PDR NETWORK, LLC, MONTVALE, NJ:
4,119,750, INT. CL. 41.

PEARLMAN, GREGORY D., DOVER, NH:
4,117,937, PUB. 1-10-2012. INT. CL. 41.
4,117,958, PUB. 1-10-2012. MULTIPLE CLASS, INT. CLS. 9
AND 25.

PEARSON, JAKE, BIG LAKE, MN:
4,118,599, PUB. 1-10-2012. INT. CL. 25.

PECHERSKY, MICHAEL, WILMINGTON, NC:
4,117,707, PUB. 1-10-2012. INT. CL. 35.

PEDERSON, SCOTT, ROSWELL, GA:
4,118,957, INT. CL. 25.

PELLERIN MILNOR CORPORATION, KENNER, LA:
1,715,054, REN. 2-22-12. INT. CL. 7.
2,597,777, REN. 2-21-12. INT. CL. 7.

PELSTAR, LLC, BROUSSARD, LA:
4,119,548, INT. CL. 37.

PENCIL, INC., NEW YORK, NY:
4,117,180, PUB. 1-10-2012. MULTIPLE CLASS, INT. CLS.
35 AND 36.

PENGUIN BOOKS LIMITED, LONDON, UNITED KING-
DOM:
2,666,054, REN. 2-22-12. INT. CL. 16.

PENGUIN GROUP (USA) INC., NEW YORK, NY, PUTNAM
BERKLEY GROUP, INC., THE, NEW YORK, NY:
1,691,533, REN. 2-22-12. INT. CL. 16.

PENN NATIONAL GAMING, INC., WYOMISSING, PA:
2,967,797, CANC. INT. CL. 41.

PENN TROY MANUFACTURING, INC., TROY, PA:
1,670,975, REN. 2-23-12. INT. CL. 7.

PENN VALLEY FARMS, LTD., CHICAGO, IL:
2,967,870, CANC. INT. CL. 30.

PENNSYLVANIA LEADERSHIP CHARTER SCHOOL, INC.,
WEST CHESTER, PA:
4,118,455, PUB. 1-10-2012. INT. CL. 41.

PENNWELL CORPORATION, TULSA, OK:
4,117,822, PUB. 1-10-2012. INT. CL. 41.
4,119,888, INT. CL. 35.

PENTECH, INC., OSWEGO, IL:
2,967,473, CANC. INT. CL. 10.

PENTON MEDIA, INC., NEW YORK, NY:
4,117,370, PUB. 1-10-2012. MULTIPLE CLASS, INT. CLS.
35 AND 42.

PENTRON ALLOYS, LLC, SAN DIEGO, CA:
2,599,683, REN. 2-22-12. INT. CL. 5.
2,606,063, REN. 2-22-12. INT. CL. 5.

PEPPERCOIN, INC., WALTHAM, MA:
2,968,089, CANC. INT. CL. 9.

PERCEPTIVE INFORMATICS, INC., WALTHAM, MA:
4,118,928, INT. CL. 38.
4,118,929, INT. CL. 44.
4,118,930, INT. CL. 42.

PERCEPTRON, INC., PLYMOUTH, MI:
4,118,251, PUB. 1-10-2012. INT. CL. 9.
4,118,252, PUB. 1-10-2012. INT. CL. 9.
4,119,120, INT. CL. 9.

PERDUE HOLDINGS, INC., WILMINGTON, DE:
1,165,714, REN. 2-21-12. INT. CL. 29.

PEREPEREZ, AGUSTIN GREGORI, ALZIRA (VALENCIA),
SPAIN AND PEREPEREZ, ALFREDO GREGORI, ALZIRA
(VALENCIA), SPAIN AND PEREPEREZ, JOSE GREGORI,
ALZIRA (VALENCIA), SPAIN:
2,923,178, CANC. MULTIPLE CLASS, INT. CLS. 29 AND
30.

PERFECT PLUS, INC., BEVERLY HILLS, CA:
4,118,245, PUB. 1-10-2012. INT. CL. 3.
4,118,246, PUB. 1-10-2012. INT. CL. 3.

PERFETTI VAN MELLE BENELUX B.V., BREDA, NETHER-
LANDS:
2,968,376, CANC. INT. CL. 30.

PERFORMANCE FOOD GROUP, INC., CENTENNIAL, CO:
2,604,769, REN. 2-22-12. MULTIPLE CLASS, INT. CLS. 29
AND 30.

PERINE, ROBIN, LOS ANGELES, CA:
4,117,788, PUB. 1-10-2012. INT. CL. 25.

PEROGEN CORPORATION, POMPANNO BEACH, FL:
4,119,796, INT. CL. 5.

PERRUCCI, GREG, LOS GATOS, CA:
4,119,699, INT. CL. 33.

PERSONALIZATIONMALL.COM, INC., BURR RIDGE, IL:
2,561,853, REN. 2-23-12. INT. CL. 35.

PERSPECTIVES CHARTER SCHOOL, CHICAGO, IL:
2,467,081, CANC. INT. CL. 41.

PET CARE CENTER, INC., METAIRIE, LA:
4,117,198, PUB. 1-10-2012. MULTIPLE CLASS, INT. CLS.
3, 5, 35, 43 AND 44.

PETELLE, JOSEPH R., KNOXVILLE, TN:
2,538,327, REN. 2-17-12. INT. CL. 7.

PETERSON, LLOYD E., NEW BRIGHTON, MN:
2,529,913, REN. 2-23-12. INT. CL. 10.

PETHEALTH SERVICES INC., OAKVILLE, CANADA:
4,119,350, MULTIPLE CLASS, INT. CLS. 35 AND 45.

PET360, INC., PLYMOUTH MEETING, PA:
4,117,356, PUB. 1-10-2012. MULTIPLE CLASS, INT. CLS.
35 AND 39.

PFIZER INC., NEW YORK, NY:
2,578,723, REN. 2-22-12. INT. CL. 5.
2,968,383, CANC. MULTIPLE CLASS, INT. CLS. 16 AND
44.
2,968,576, CANC. INT. CL. 5.
4,119,282, INT. CL. 5.

PG PUBLISHING CO., PITTSBURGH, PA:
2,468,033, CANC. INT. CL. 42.

PGI POLYMER, INC., WILMINGTON, DE:
1,185,839, REN. 2-22-12. INT. CL. 21.

PGI POLYMER, INC., CHARLOTTE, NC, JOHNSON &
JOHNSON, NEW BRUNSWICK, NJ:
1,187,714, REN. 2-22-12. INT. CL. 21.

PHANTOM COACHES HEARSE CLUB, TEHACHAPI, CA:
2,466,851, CANC. INT. CL. 42.

PHANTOM INCORPORATED, EDMONTON, ALBERTA,
CANADA:
2,968,699, CANC. INT. CL. 41.

PHAT FASHIONS LLC, NEW YORK, NY:
2,541,251, REN. 2-22-12. INT. CL. 18.

PHI BETA KAPPA SOCIETY, WASHINGTON, DC, UNITED
CHAPTERS OF PHI BETA KAPPA, WASHINGTON, DC:
731,963, REN. 2-19-12. U.S. CL. 200.

- PHI BETA KAPPA SOCIETY, WASHINGTON, DC:
734,333. REN. 2-19-12. U.S. CL. 200.
- PHILADELPHIA UNIVERSITY, PHILADELPHIA, PA:
4,117,996. PUB. 1-10-2012. INT. CL. 41.
- PHILADELPHIA 76ERS L.P., PHILADELPHIA, PA:
4,118,926. INT. CL. 38.
- PHILIP HARTMAN, NEW YORK, NY:
4,118,209. PUB. 1-10-2012. INT. CL. 43.
4,118,220. PUB. 1-10-2012. INT. CL. 43.
- PHILIP MORRIS USA INC., RICHMOND, VA, PHILIP MORRIS & CO. LTD., INCORPORATED, NEW YORK, NY:
552,831. REN. 2-21-12. U.S. CL. 17 (INT. CL. 34).
- PHILIP MORRIS USA INC., RICHMOND, VA:
4,118,021. PUB. 1-10-2012. INT. CL. 34.
- PHILLIPS, SALLIE T., BUFFALO GROVE, IL:
2,467,255. CANC. INT. CL. 10.
- PHILOSOPHIKIETAIRTA TO TAGMA TOY KRINOU KAI TOU AETOU, GREECE:
4,116,763. PUB. 1-10-2012. MULTIPLE CLASS, INT. CLS. 16, 41 AND 42.
- PHILOSOPHY, INC., PHOENIX, AZ:
2,976,723. CANC. INT. CL. 3.
4,117,675. PUB. 1-10-2012. INT. CL. 3.
- PHIT HAIR AND BODY, INC., SOLANA BEACH, CA:
4,119,614. INT. CL. 3.
- PHOENIX REALTY ADVISORS, INC., PHOENIX, AZ:
4,117,241. PUB. 1-10-2012. INT. CL. 36.
- PHONEZIP, INC., BURKE, VA, AKA PHONEZIP.COM:
4,116,902. PUB. 1-10-2012. INT. CL. 35.
- PHYSICIANS CARE ALLIANCE, LLC, SCOTTSDALE, AZ:
4,116,932. PUB. 1-10-2012. INT. CL. 5.
- PHYSICIANS LIFE CENTERS LLC, NAPLES, FL:
4,118,267. PUB. 1-10-2012. INT. CL. 44.
- PHYSICIANS' ORGANIZATION OF WESTERN MICHIGAN, INC., GRAND RAPIDS, MI:
4,117,797. PUB. 1-10-2012. INT. CL. 35.
- PHYSIQUE NUTRITION, LLC, MIAMI BEACH, FL:
2,968,402. CANC. INT. CL. 5.
- PHYTOPHARM PLC., CAMBRIDGESHIRE PE29 2HY, ENGLAND:
2,965,627. CANC. MULTIPLE CLASS, INT. CLS. 5, 40, 42 AND 44.
- PICCIONELLI GREGORY A., ENCINO, CA:
4,118,798. INT. CL. 35.
- PICK-N-DICKERS, SPARKS, NV:
4,118,116. PUB. 1-10-2012. INT. CL. 35.
- PICOKINETIX, PORTLAND, OR:
4,119,563. INT. CL. 9.
- PIECES OF PLACES LLC, FAIRFIELD, CT:
2,968,628. CANC. INT. CL. 35.
- PILLAR HOTELS AND RESORTS, L.P., IRVING, TX:
4,119,298. INT. CL. 35.
- PILLER, MAURICE, FERNAND, KNOXVILLE, TN:
2,968,042. CANC. INT. CL. 8.
- PINCHOT INSTITUTE FOR CONSERVATION, WASHINGTON, DC:
4,116,956. PUB. 1-10-2012. INT. CL. 42.
- PINEDA COVALIN S.A. DE C.V., MEXICO CITY, D.F., MEXICO:
2,541,397. REN. 2-22-12. INT. CL. 25.
- PINK CAKE BOX LLC, DENVER, NJ:
4,116,555. PUB. 1-10-2012. INT. CL. 35.
- PINKERTON SERVICE CORPORATION, PARISIPPANY, NJ, PINKERTON'S NATIONAL DETECTIVE AGENCY, INC., NEW YORK, NY:
546,426. REN. 2-21-12. U.S. CL. 100 (INT. CL. 42).
- PINKERTON, MILO, WAYZATA, MN:
2,648,839. REN. 2-23-12. INT. CL. 36.
- PINNACLE FOODS GROUP, INC., MOUNTAIN LAKES, NJ:
2,968,574. CANC. INT. CL. 29.
- PINNACLE HEALTH, INC., MARLBOROUGH, MA:
4,116,913. PUB. 1-10-2012. INT. CL. 35.
- PINPOINTS X LTD., KFAR SAVA, ISRAEL:
4,118,748. PUB. 12-6-2011. INT. CL. 45.
- PIONEER HI-BRED INTERNATIONAL, INC., JOHNSTON, IA:
726,844. REN. 2-22-12. U.S. CL. 1 (INT. CL. 31).
1,677,853. REN. 2-21-12. INT. CL. 36.
4,119,050. INT. CL. 31.
- PIONEER PET PRODUCTS, LLC, CEDARBURG, WI:
4,119,695. INT. CL. 28.
- PIPISTREL D.O.O. AJDOVSCINA, SI-5270 AJDOVSCINA, SLOVENIA:
4,085,960. COR. INT. CL. 12.
- PIRELLI & C. S.P.A., ITALY:
4,116,858. PUB. 1-10-2012. INT. CL. 12.
- PITNEY BOWES INC., STAMFORD, CT:
4,118,747. PUB. 1-10-2012. INT. CL. 35.
- PITONYAK MACHINERY CORPORATION, CARLISLE, AR:
4,119,775. INT. CL. 7.
- PIXEL PARTIES LLC, WILLIS, TX:
4,117,618. PUB. 1-10-2012. INT. CL. 41.
- PIZZA HUT, INC., PLANO, TX:
926,516. REN. 2-19-12. U.S. CL. 46 (INT. CL. 29).
- PKNY IP & FRANCHISE, LLC, NEW YORK, NY:
2,967,773. CANC. INT. CL. 29.
- PLAMBECK HOLDING AG, FED REP GERMANY:
4,116,765. PUB. 10-4-2011. MULTIPLE CLASS, INT. CLS. 9 AND 38.
- PLAMONDON, LINDA A., HAVERHILL, MA, DBA AWAKE HYPNOSIS:
4,119,844. INT. CL. 44.
- PLANET AUTO WASH, LLC, MANASSAS, VA:
4,117,250. PUB. 1-10-2012. INT. CL. 37.
- PLASTIC INJECTION COMMAND, INC., CHAPPAQUA, NY:
2,967,717. CANC. INT. CL. 28.
- PLAYBOY ENTERPRISES INTERNATIONAL, INC., CHICAGO, IL:
2,968,552. CANC. INT. CL. 42.
3,172,072. COR. INT. CL. 35.
- PLEXICOR (USA) INC., ANNAPOLIS, MD:
2,529,684. REN. 2-21-12. INT. CL. 11.
- PLI-DEK, INC., MURRIETA, CA:
2,522,325. REN. 2-21-12. INT. CL. 37.
- PLONK WINE MERCHANTS, LLC, BEVERLY HILLS, CA:
4,117,062. PUB. 1-10-2012. INT. CL. 35.
- PLUS ITS CHEAP LLC, MONSEY, NY:
4,117,846. PUB. 1-10-2012. INT. CL. 11.
- PLX TECHNOLOGY, INC., SUNNYVALE, CA:
4,117,189. PUB. 1-10-2012. INT. CL. 9.
- PLYMOUTH TRADING COMPANY, LLC, PLYMOUTH, MN:
4,119,612. INT. CL. 16.
- PMC-SIERRA, INC., SUNNYVALE, CA:
1,671,656. REN. 2-23-12. INT. CL. 9.
- POBER, YESPELKIS AND ASSOCIATES, INC., VILLAGE OF PALMETTO BAY, FL:
2,467,517. CANC. INT. CL. 35.
- POCZTA KWIATOWA SP. Z O.O., 00-087 WARSAW, POLAND:
4,094,997. CANC. IIRN. RESTORED TO S.N. 77-893,525.
- PODERNUOVO S.R.L. SOCIETÀ AGRICOLA, ITALY:
4,116,864. PUB. 1-10-2012. INT. CL. 33.
- POLA CHEMICAL INDUSTRIES INC., SHIZUOKA-KEN 422-8009, JAPAN:
4,116,817. PUB. 1-10-2012. INT. CL. 1.
- POLATIS, INC., ANDOVER, MA:
4,118,360. PUB. 1-10-2012. INT. CL. 9.
4,118,361. PUB. 1-10-2012. INT. CL. 9.
- POLCINO, DAVE CORWIN, HOLLYWOOD, CA:
4,117,759. PUB. 1-10-2012. INT. CL. 41.
- POLE SPORT ENTERPRISE INC., NEW YORK, NY:
4,117,725. PUB. 1-10-2012. INT. CL. 36.
- POLYCHROMIX, INC., WILMINGTON, MA:
2,968,127. CANC. INT. CL. 9.
2,968,128. CANC. INT. CL. 9.
- POLYGRAM HOLDING, INC., SANTA MONICA, CA:
4,118,828. INT. CL. 41.
- POLYMEDIX, INC., RADNOR, PA:
4,118,719. PUB. 1-10-2012. INT. CL. 5.
- POLYSOFT PRODUCTS INC., PARAMUS, NJ:
3,164,685. CANC. MULTIPLE CLASS, INT. CLS. 16 AND

21.
POMA GLASS & SPECIALTY WINDOWS, INC., KINGSPORT, TN, INTEREDGE TECHNOLOGIES, L.L.C., PARKLAND, FL:
2,464,479. REN. 2-22-12. INT. CL. 19.
- POP CRAFT, SARASOTA, FL:
4,117,942. PUB. 1-10-2012. INT. CL. 30.
- POPULAR, INC., SAN JUAN, PUERTO RICO:
2,467,525. CANC. INT. CL. 36.
- PORT ST. JOE PORT AUTHORITY, PORT ST. JOE, FL:
2,833,622. CANC. INT. CL. 39.
- PORTFOLIO PATHWAY, LLC, NAPERVILLE, IL:
4,118,882. INT. CL. 42.
- PORTIONPAC CHEMICAL CORPORATION, CHICAGO, IL:
4,119,125. MULTIPLE CLASS, INT. CLS. 3, 5 AND 41.
- PORTLAND PEDAL POWER, LLC, PORTLAND, OR:
4,118,596. PUB. 1-10-2012. INT. CL. 35.
- PORTOLANO PRODUCTS, INC., NEW YORK, NY:
2,564,545. REN. 2-21-12. INT. CL. 25.
4,119,494. INT. CL. 25.
- POSERA INC., MONTREAL, QUEBEC, CANADA:
2,638,149. REN. 2-17-12. INT. CL. 9.
- POTOMAC RIVER RUNNING, INC., MCLEAN, VA, AKA = PR = RUNNING:
4,117,957. PUB. 1-10-2012. INT. CL. 41.
- POWDR-WOODWARD PA LLC, PARK CITY, UT:
4,117,484. PUB. 1-10-2012. INT. CL. 41.
- POWELL ELECTRICAL SYSTEMS, INC., HOUSTON, TX:
4,119,086. INT. CL. 9.
- POWELL, JAY H, FRISCO, TX, DBA AUCET TECHNOLOGIES:
4,118,382. PUB. 1-10-2012. INT. CL. 38.
- POWER BALANCE, LLC, LAGUNA NIGUEL, CA:
4,118,746. PUB. 1-10-2012. MULTIPLE CLASS, INT. CLS. 14 AND 16.
- POWER ELECTRONICS INTERNATIONAL, INC., EAST DUNDEE, IL:
2,529,547. REN. 2-22-12. INT. CL. 9.
- POWER MONITORS, INC., MT. CRAWFORD, VA:
1,673,112. REN. 2-22-12. INT. CL. 9.
- POWER MONITORS, INC., MOUNT CRAWFORD, VA:
4,119,526. INT. CL. 9.
- PPG INDUSTRIES OHIO, INC., CLEVELAND, OH:
1,671,461. REN. 2-22-12. INT. CL. 12.
- PPTP.NET, LLC, BEACH HAVEN, NJ:
4,119,377. INT. CL. 44.
4,119,378. INT. CL. 44.
4,119,379. INT. CL. 44.
- PRACTICEGENIUS LLC, SAN DIEGO, CA:
4,118,760. INT. CL. 35.
4,118,761. INT. CL. 35.
- PRATIMA RAWAL, KENSAL GREEN, LONDON, UNITED KINGDOM:
4,119,879. INT. CL. 35.
- PRECISION FOODS, INC., ST. LOUIS, MO, DACUS DRUG COMPANY, INC., TUPELO, MS:
952,764. REN. 2-23-12. U.S. CL. 46 (INT. CL. 1).
- PREDATOR QUEST, L.L.C., EDGAR, NE:
4,118,922. MULTIPLE CLASS, INT. CLS. 9, 13 AND 20.
- PREMIER PAINT ROLLER COMPANY LLC, RICHMOND HILL, NY:
2,545,124. REN. 2-23-12. INT. CL. 16.
- PREMIERE RADIO NETWORKS, INC., SAN ANTONIO, TX:
4,117,463. PUB. 1-10-2012. MULTIPLE CLASS, INT. CLS. 38 AND 41.
- PREMIUM SPRAY PRODUCTS, INC., MARIETTA, GA:
4,117,011. PUB. 1-10-2012. INT. CL. 17.
- PRESOTTO INDUSTRIE MOBILI S.R.L., MARON DI BRUGNERA, ITALY:
2,968,277. CANC. INT. CL. 20.
- PRESS GANEY ASSOCIATES, INC, SOUTH BEND, IN:
4,119,863. INT. CL. 35.
- PRETTY UGLY LLC, EDISON, NJ AND HORVATH, DAVID, EDISON, NJ AND KIM, SUN-MIN, EDISON, NJ:
4,118,519. PUB. 1-10-2012. INT. CL. 28.
4,118,593. PUB. 1-10-2012. INT. CL. 28.
- PREVENT CANCER FOUNDATION, ALEXANDRIA, VA:
2,467,825. CANC. INT. CL. 42.
- PREVENTION MEDS, INC., LEBANON, NJ:
4,118,427. PUB. 1-10-2012. INT. CL. 5.
- PRICE, ALLEN, CAMERON PARK, CA:
2,967,839. CANC. INT. CL. 35.
- PRICE, SCOTT, GUILDERLAND CENTER, NY, DBA UNIRI:
4,118,331. PUB. 1-10-2012. INT. CL. 41.
- PRICEWATERHOUSECOOPERS LLP, NEW YORK, NY:
2,967,800. CANC. INT. CL. 36.
- PRIMA EYE GROUP, INC., ATLANTA, GA:
4,117,332. PUB. 1-10-2012. INT. CL. 35.
- PRIMERA RED INTERACTIVA DE MEDIOS ARGENTINOS (PRIMA) S.A., BUENOS AIRES, ARGENTINA:
2,967,374. CANC. MULTIPLE CLASS, INT. CLS. 38 AND 42.
- PRIMEX HOLDINGS, LLC, NEW YORK, NY:
2,468,398. CANC. INT. CL. 9.
- PRIMUS TELECOMMUNICATIONS IHC, INC., MCLEAN, VA:
2,679,710. REN. 2-22-12. INT. CL. 38.
- PRINCE AGRI PRODUCTS, INC., QUINCY, IL:
4,117,774. PUB. 1-10-2012. INT. CL. 42.
- PRINCETON MINING COMPANY, INC., TERRE HAUTE, IN:
2,524,535. REN. 2-22-12. INT. CL. 35.
- PRITCHARD, JOSHUA, LA SELVA BEACH, CA:
4,117,178. PUB. 1-10-2012. INT. CL. 42.
- PRIVATE WEALTH GROUP, LLC, TAMPA, FL:
4,119,518. INT. CL. 36.
- PRL USA HOLDINGS, INC., NEW YORK, NY, LAUREN AND MARK N. KAPLAN, CO-TRUSTEES OF THE RALPH LAUREN TRUST OF 9/21/76; RICKY, NEW YORK, NY:
1,212,059. REN. 2-17-12. INT. CL. 3.
- PRO BONO NET, INC., NEW YORK, NY:
4,118,368. PUB. 1-10-2012. INT. CL. 35.
4,118,370. PUB. 1-10-2012. INT. CL. 35.
4,118,374. PUB. 1-10-2012. INT. CL. 35.
- PRO PHOTO CONNECTION, INC., IRVINE, CA:
2,967,879. CANC. MULTIPLE CLASS, INT. CLS. 16 AND 41.
- PRO QUALITY CLEANING, LLC, CAMP HILL, PA 17011, PA:
4,118,127. PUB. 1-10-2012. INT. CL. 37.
- PRO VIEW WINDOWS, INC., ELMHURST, IL:
4,118,330. PUB. 1-10-2012. INT. CL. 37.
- PRO-FORMANCE, INC., THE WOODLANDS, TX, WHALEY, WAYNE J., HOUSTON, TX AND CASSELL, DAVID R., HOUSTON, TX:
1,720,917. REN. 2-22-12. INT. CL. 42.
- PRO-1 CONSTRUCTION SERVICES CO., LOMBARD, IL, DBA PRO-1 CONSTRUCTION:
4,117,523. PUB. 1-10-2012. INT. CL. 37.
- PROBOARDS, INC., LAKE FOREST, CA:
2,663,391. REN. 2-22-12. INT. CL. 42.
- PROCTER & GAMBLE COMPANY, THE, CINCINNATI, OH:
929,735. REN. 2-21-12. U.S. CL. 52 (INT. CL. 3).
- PRODOH, LLC, GREENVILLE, SC:
4,119,645. INT. CL. 25.
4,119,646. INT. CL. 25.
- PRODUCERS AG INSURANCE GROUP, INC., AMARILLO, TX:
4,117,000. PUB. 1-10-2012. INT. CL. 36.
- PRODUCT CLUB CORP, ROCKAWAY, NJ:
2,968,411. CANC. INT. CL. 25.
- PRODUCTION PHOTO/GRAPHICS, INC., HAWTHORNE, CA:
2,968,497. CANC. INT. CL. 35.
- PROFASHION, INC., CHARLOTTE, NC:
4,118,617. PUB. 1-10-2012. INT. CL. 9.
- PROFESSIONAL GOLFERS' ASSOCIATION OF AMERICA, PALM BEACH GARDENS, FL:
1,678,437. REN. 2-23-12. MULTIPLE CLASS, INT. CLS. 14, 25 AND 28.
- PROFESSIONAL MORTGAGE SOLUTIONS, INC., REGO PARK, NY:
2,968,112. CANC. INT. CL. 36.
- PROFILE PRODUCTS LLC, BUFFALO GROVE, IL:
4,118,218. PUB. 1-10-2012. INT. CL. 35.

- PROGRESSIVE CASUALTY INSURANCE COMPANY, MAYFIELD VILLAGE, OH:
4,119,717, INT. CL. 35.
- PROGRESSIVE LABORATORIES, INC., IRVING, TX, DBA KORDIAL NUTRIENTS:
4,118,674, PUB. 1-10-2012. INT. CL. 5.
- PROGRESSIVE SYSTEMS, INC., BERE A, KY:
2,467,779, CANC. MULTIPLE CLASS, INT. CLS. 7 AND 40.
- PROJETCLUB, VILLENEUVE D'ASC, FRANCE:
4,118,355, PUB. 1-10-2012. MULTIPLE CLASS, INT. CLS. 9, 18, 25 AND 28.
- PROLONG PHARMACEUTICALS, LLC, SOUTH PLAINFIELD, NJ:
4,117,771, PUB. 1-10-2012. INT. CL. 5.
- PROMEGA CORPORATION, MADISON, WI:
2,555,969, REN. 2-22-12. INT. CL. 5.
- PROMETHEUS NEMESIS BOOK COMPANY, GREEN VALLEY LAKE, CA:
4,117,475, PUB. 1-10-2012. INT. CL. 42.
- PROMEX TECHNOLOGIES, LLC, FRANKLIN, IN:
2,968,529, CANC. INT. CL. 10.
- PROMOTIECENTRUM VOOR HET VLAS - VERENIGING ZONDER WINSTOOGMERK WINSTOOGMERK, BELGIUM:
4,116,709, PUB. 1-10-2012. MULTIPLE CLASS, INT. CLS. 23 AND 24.
- PROPEL SOFTWARE CORPORATION, SAN JOSE, CA:
2,467,518, CANC. INT. CL. 42.
- PROPHARMCARE, INC, ORANGE, CA:
4,117,794, PUB. 1-10-2012. INT. CL. 44.
- PROPHASE LABS, INC., DOYLESTOWN, PA, FORMERLY THE QUIGLEY CORPORATION:
4,117,108, PUB. 1-10-2012. INT. CL. 5.
- PROQUEST LLC, ANN ARBOR, MI:
2,567,241, REN. 2-17-12. INT. CL. 42.
- PROSEEDS MARKETING, INC., JEFFERSON, OR:
4,118,894, INT. CL. 1.
- PROTECTIVE INDUSTRIAL PRODUCTS, INC., ALBANY, NY:
1,160,755, REN. 2-22-12. INT. CL. 9.
- PROTEK ME LLC, TAMARAC, FL:
4,119,208, INT. CL. 9.
- PROTREND, LTD., COMMERCE, CA:
4,119,226, INT. CL. 25.
- PROVINDUS, INC., SALEM, UT:
4,118,413, PUB. 1-10-2012. INT. CL. 5.
- PROXIMO SPIRITS, INC., JERSEY CITY, NJ:
4,119,731, INT. CL. 33.
- PRUDENTIAL INSURANCE COMPANY OF AMERICA, THE, NEWARK, NJ:
2,528,657, REN. 2-23-12. INT. CL. 36.
- PRZYBYLO, DAVID, SCHENECTADY, NY:
4,119,654, INT. CL. 41.
- PSA ESSENTIALS, L.L.C., BIRMINGHAM, MI:
2,967,705, CANC. INT. CL. 16.
- PSMJ RESOURCES, INC., NEWTON, MA:
2,527,282, REN. 2-21-12. INT. CL. 41.
- PSS POLYMER STANDARDS SERVICE GMBH, D-55023 MAINZ, FED REP GERMANY:
2,467,095, CANC. MULTIPLE CLASS, INT. CLS. 1 AND 9.
- PSW HOMES, LLC., AUSTIN, TX, DBA PSW HOMES:
4,118,208, PUB. 1-10-2012. INT. CL. 37.
- PT MANAGEMENT, INC., ST. GEORGE, UT:
4,117,886, PUB. 1-10-2012. INT. CL. 35,
4,117,888, PUB. 1-10-2012. INT. CL. 41.
- PUBLIC STORAGE, GLENDALE, CA:
2,525,614, REN. 2-21-12. INT. CL. 36.
- PUBLICOM, INC., ROCKY MOUNT, VA:
2,968,618, CANC. INT. CL. 10.
- PUDDLES LIMITED, TORTOLA, BR.VIRGIN ISLANDS:
2,968,308, CANC. INT. CL. 25.
- PUMA SE, FED REP GERMANY:
4,116,734, PUB. 1-10-2012. INT. CL. 9.
- PUMPERNICKEL PRESS, LLC, BERRYVILLE, VA AND JAMES, CINDY, LEESBURG, VA, DBA HEAVENLY DESIGNS:
2,967,850, CANC. MULTIPLE CLASS, INT. CLS. 16 AND 20.
- PUNITA LEATHERS, INC., CHANTILLY, VA:
2,968,233, CANC. INT. CL. 18.
- PUP SQUAD ANIMAL RESCUE, HOUSTON, TX:
4,117,427, PUB. 1-10-2012. INT. CL. 45.
- PURDY, DANIEL C., OTTAWA, ONTARIO, CANADA:
2,882,829, CANC. INT. CL. 41.
- PURE FISHING, INC., SPIRIT LAKE, IA, JOHNSON FISHING, INC., MANKATO, MN:
1,670,372, REN. 2-22-12. INT. CL. 28.
- PURE MATRIX, INC., WESTMINSTER, CO:
2,967,419, CANC. INT. CL. 42.
- PURE REBELLION MINISTRIES, COLORADO SPRINGS, CO:
4,117,694, PUB. 1-10-2012. INT. CL. 41.
- PUSSYCAT DOLLS, LLC, SANTA MONICA, CA:
4,118,837, INT. CL. 18.
- PUZHEN LIFE CO., LIMITED, SHATIN NEW TERRITORIES, HONG KONG:
4,117,035, PUB. 1-10-2012. INT. CL. 11.
- PWG HOLDINGS, LLC, LAKE MARY, FL:
4,119,303, INT. CL. 35.
- PYE RICHARD L, DARTMOUTH, NOVA SCOTIA, CANADA, TA MAKE UP SEXX:
4,118,444, PUB. 1-10-2012. INT. CL. 3.
- PYLON MANUFACTURING CORP., DEERFIELD BEACH, FL:
2,669,082, REN. 2-22-12. INT. CL. 12.
- P1 HOLDINGS, LLC, NEW YORK, NY:
4,118,966, MULTIPLE CLASS, INT. CLS. 35 AND 36.
- Q-PLUS LABS, A QPL TECHNOLOGIES, INC. COMPANY, IRVINE, CA:
4,118,258, PUB. 1-10-2012. INT. CL. 42.
- QANTAS AIRWAYS LIMITED, MASCOT, AUSTRALIA:
2,874,476, CANC. INT. CL. 12.
- QIAGEN GAITHERSBURG, INC., GAITHERSBURG, MD:
2,967,728, CANC. INT. CL. 5.
- QIAN LU, SOLON, OH:
4,117,371, PUB. 1-10-2012. INT. CL. 42.
- QIP HOLDER LLC, DENVER, CO:
2,540,306, REN. 2-22-12. INT. CL. 30.
- QRXPHERMA LIMITED, NORTH SYDNEY, NSW, AUSTRALIA:
4,118,276, PUB. 1-10-2012. INT. CL. 5.
- QUADRAMED QUANTIM CORPORATION, RESTON, VA:
2,524,949, REN. 2-23-12. INT. CL. 9.
- QUALCOMM INNOVATION CENTER, INC., SAN DIEGO, CA:
4,118,476, PUB. 1-10-2012. INT. CL. 9.
- QUALITY CRAFT LTD., SURREY, CANADA:
4,116,599, PUB. 1-10-2012. MULTIPLE CLASS, INT. CLS. 19 AND 20.
- QUALITY GROWERS FLORAL COMPANY, INC., DELEON SPRINGS, FL:
4,118,213, PUB. 1-10-2012. INT. CL. 31.
- QUALITY SOFTWARE SERVICES, INC., COLUMBIA, MD:
4,117,565, PUB. 10-4-2011. INT. CL. 9.
- QUAN DENG PING, HUNAN, CHINA:
4,116,758, PUB. 1-10-2012. INT. CL. 9.
- QUARTERMAN, SAMANTHA, MIAMI, FL:
4,116,986, PUB. 1-10-2012. INT. CL. 41.
- QUEMED INTERNATIONAL, INC., GAINESVILLE, TX:
4,118,326, PUB. 1-10-2012. INT. CL. 35.
- QUESOS LA PARDINA, S.L, VALENCIA, SPAIN:
4,119,531, INT. CL. 29.
- QUEST MEDICAL, INC., ALLENTOWN, TX:
1,190,586, REN. 2-21-12. INT. CL. 10.
- QUEST METAL SOLUTIONS, INC., FORT WORTH, TX:
4,118,974, MULTIPLE CLASS, INT. CLS. 37, 40 AND 42.
- QUICK CATCH LABS LLC, BELMONT, MA:
4,117,513, PUB. 1-10-2012. INT. CL. 38.
- QUICKPLAY MEDIA INC., TORONTO, CANADA:
4,119,061, MULTIPLE CLASS, INT. CLS. 9 AND 38.
- QUIKTRIP WEST, INC., WICHITA, KS:
4,118,738, PUB. 1-10-2012. MULTIPLE CLASS, INT. CLS. 29 AND 30.

QUILL MEDICAL, INC., RESEARCH TRIANGLE PARK, NC:
2,967,464, CANC. INT. CL. 10.

QUORA, INC., PALO ALTO, CA:
4,119,032, INT. CL. 38.
4,119,033, MULTIPLE CLASS, INT. CLS. 42 AND 45.

QZINA SPECIALTY FOODS, INC., POMPANO BEACH, FL:
3,160,569, CANC. INT. CL. 35.

R & D LIFESCIENCES, MENOMONIE, WI:
4,119,660, INT. CL. 5.

R & D LIFESCIENCES, LLC, MENOMONIE, WI:
4,119,650, INT. CL. 5.

R. L. POLK & CO., SOUTHFIELD, MI:
4,116,900, PUB. 1-10-2012. INT. CL. 35.

R. TORRE & COMPANY, SOUTH SAN FRANCISCO, CA:
1,714,012. REN. 2-23-12. MULTIPLE CLASS, INT. CLS. 32 AND 33.

R.B. MARKETING SRL UNIPERSONALE, ITALY:
4,116,755, PUB. 1-10-2012. INT. CL. 11.

R.W. MARTIN & SONS, INC., KENT, OH:
2,467,346, CANC. MULTIPLE CLASS, INT. CLS. 35, 37 AND 42.

R&D CLOUD, INC., MARINA DEL REY, CA:
4,117,932, PUB. 1-10-2012. INT. CL. 42.
4,117,933, PUB. 1-10-2012. INT. CL. 42.

RACEWORKS, LLC, HOUSTON, TX:
2,968,104, CANC. INT. CL. 25.

RADARESAS, INC., TARZANA, CA:
2,967,749, CANC. MULTIPLE CLASS, INT. CLS. 11 AND 21.

RADER, THEODORE W, FINDLAY, OH:
4,118,597, PUB. 1-10-2012. INT. CL. 40.

RADIAL ASSIST, LLC, ROSWELL, GA:
4,119,488, INT. CL. 10.

RADIO GENERAL, LTD., KENTON, OH:
2,531,723. REN. 2-23-12. INT. CL. 41.

RADIODETECTION LIMITED, BRISTOL, UNITED KINGDOM:
4,118,129, PUB. 1-10-2012. INT. CL. 9.

RADIOVISA CORPORATION, SHERMAN OAKS, CA:
2,967,776, CANC. INT. CL. 38.

RADIUS CORPORATION, KUTZTOWN, PA:
4,119,889, INT. CL. 21.

RADWELL INTERNATIONAL INC., LUMBERTON, NJ:
4,118,826, INT. CL. 35.

RAEMICA, INC., HIGHLAND, CA:
4,116,999, PUB. 1-10-2012. INT. CL. 29.

RAFFLES INTERNATIONAL LIMITED, SINGAPORE, SINGAPORE:
2,967,557, CANC. MULTIPLE CLASS, INT. CLS. 3, 25, 41, 43 AND 44.

RAGASA INDUSTRIAS, S.A. DE C.V., MONTERREY, N.L., MEXICO:
4,117,403, PUB. 1-10-2012. INT. CL. 29.

RAGDOLL WORLDWIDE LTD, IVER HEATH SLOONH, UNITED KINGDOM, RAGDOLL LTD., IVER HEATH, BUCKINGHAMSHIRE, SLO ONH, ENGLAND:
2,463,224. REN. 2-22-12. INT. CL. 28.

RAGE BEVERAGES INC., MONTREAL, QUEBEC, CANADA:
4,118,486, PUB. 1-10-2012. MULTIPLE CLASS, INT. CLS. 5 AND 32.

RAINER GMBH, FED REP GERMANY:
3,746,874, COR. MULTIPLE CLASS, INT. CLS. 16, 20, 22 AND 39.

RAINFOREST NUTRITIONALS INCORPORATED, RALEIGH, NC:
2,968,140, CANC. INT. CL. 5.

RAINMAKER SYSTEMS, INC., CAMPBELL, CA:
4,116,614, PUB. 1-10-2012. INT. CL. 35.

RALPH DIMEO, SOUTH ORANGE, NJ, DBA ALEX OUTDOORS:
4,116,977, PUB. 1-10-2012. MULTIPLE CLASS, INT. CLS. 25 AND 35.

RAMAR INTERNATIONAL CORPORATION, PITTSBURG, CA:
4,117,017, PUB. 10-4-2011. MULTIPLE CLASS, INT. CLS. 29, 30 AND 32.

RAMONA DOOLEY, STANHOPE, NJ:
4,117,917, PUB. 1-10-2012. INT. CL. 16.

RAMOS-MATA, WILFRIDO, THE WOODLANDS, TX:
4,117,727, PUB. 1-10-2012. INT. CL. 35.

RAMSER, PHILIP, TUSTIN, CA:
4,118,609, PUB. 1-10-2012. INT. CL. 39.

RANDALL-REILLY PUBLISHING COMPANY, LLC, TUSCALOOSA, AL:
4,118,986, INT. CL. 16.
4,118,987, INT. CL. 41.

RANDSTEEL, LLC, CARSON CITY, NV:
4,117,271, PUB. 1-10-2012. INT. CL. 35.

RANDY HANGERS, L.L.C., EAST RUTHERFORD, NJ:
2,547,280. REN. 2-21-12. INT. CL. 20.

RANGEL, LISA M, RUTHERFORD, NJ:
4,118,126, PUB. 1-10-2012. INT. CL. 35.

RANGER PLUMBING & HEATING INC., LIVINGSTON, MT:
4,118,096, PUB. 1-10-2012. INT. CL. 37.

RATICAN, CHRISTOPHER C., FORT PIERCE, FL:
2,967,556, CANC. INT. CL. 9.

RAUL EQUINE, INC., BOHEMIA, NY, DBA RAUL E NEW YORK:
4,117,742, PUB. 1-10-2012. MULTIPLE CLASS, INT. CLS. 3, 14, 18, 25 AND 28.

RAVENSTEIN, JOHN, JACKSON, MS:
2,967,684, CANC. INT. CL. 14.

RAWLINGS SPORTING GOODS COMPANY INC, ST. LOUIS, MO, A-T-O INC., ST. LOUIS, MO:
1,190,090. REN. 2-21-12. INT. CL. 28.

RAYMARINE UK LIMITED, PORTSMOUTH, HAMPSHIRE, UNITED KINGDOM:
4,117,034, PUB. 1-10-2012. INT. CL. 36.

RAYNE CORPORATION, VENTURA, CA:
2,466,922, CANC. INT. CL. 35.

RAZZAK, HAJI ABDUL, DUBAI, UNITED ARAB EMIRATES, PAKISTAN AND IQBAL, MOHAMMED, DUBAI, UNITED ARAB EMIRATES, PAKISTAN:
2,468,075, CANC. INT. CL. 14.

RBC MINISTRIES, GRAND RAPIDS, MI:
731,961. REN. 2-21-12. U.S. CL. 107 (INT. CL. 41).

RDP PRODUCTIONS, INC., NAPLES, FL:
4,119,768, INT. CL. 21.

RE:INVENTION, INC., CORONADO, CA:
4,118,739, PUB. 1-10-2012. INT. CL. 35.

REACT TO FILM INC., WASHINGTON, DC:
4,117,984, PUB. 1-10-2012. MULTIPLE CLASS, INT. CLS. 35 AND 41.

READY PAC PRODUCE, INC., IRWINDALE, CA:
2,556,000. REN. 2-22-12. INT. CL. 29.

REAL ESTATE IRA UNIVERSITY, INC., GOLDEN, CO:
4,119,214, INT. CL. 42.

REBATECITY.COM LLC, WILMINGTON, DE:
4,119,306, INT. CL. 35.

REBECCA MICHELLE DOWNIN, DAVENPORT, FL:
4,119,630, INT. CL. 14.

REBECCA SCRITCHFIELD MEDIA, LLC, WASHINGTON, DC:
4,118,587, PUB. 1-10-2012. INT. CL. 41.

RECIGNO LABORATORIES INC., WILLOW GROVE, PA:
2,465,573. REN. 2-22-12. INT. CL. 10.
2,465,574. REN. 2-22-12. INT. CL. 10.
2,465,575. REN. 2-22-12. INT. CL. 10.
2,467,686, CANC. INT. CL. 10.

RECIPPEEPS, INC., JACKSONVILLE, FL:
4,119,512, MULTIPLE CLASS, INT. CLS. 38, 42 AND 45.

RECORD WATCH CO. SA, 2610 SAINT-IMIER, SWITZERLAND:
4,118,793, INT. CL. 14.

RECORDING INDUSTRY ASSOCIATION OF AMERICA, INC., WASHINGTON, DC:
2,967,360, CANC. INT. CL. 9.

RECYCLINE, INC., WALTHAM, MA:
4,117,226, PUB. 1-10-2012. INT. CL. 37.

RED HAT, INC., RALEIGH, NC:
3,042,909, CANC. INT. CL. 16.

RED LAMBDA, INC., LONGWOOD, FL:
4,116,915, PUB. 1-10-2012. MULTIPLE CLASS, INT. CLS. 9

- AND 42.
RED MERCURY, LLC, GLENVIEW, IL:
2,520,317. REN. 2-22-12. INT. CL. 9.
RED SLATE BRANDS, INC., ROAD TOWN, BR.VIRGIN ISLANDS:
4,119,397, INT. CL. 28.
RED THUNDER STUDIO OF GEORGIA, LLC, ATLANTA, GA:
2,967,791, CANC. INT. CL. 25.
RED VELVET CUPCAKES BY MICHELLE LLC, ROYAL OAK, MI, DBA TASTE LOVE CUPCAKES:
4,117,840, PUB. 1-10-2012. INT. CL. 30.
RED WING SOFTWARE, INC., RED WING, MN:
4,117,705, PUB. 1-10-2012. INT. CL. 9.
RED.COM, INC., IRVINE, CA:
4,117,058, PUB. 1-10-2012. INT. CL. 9.
REDA YAMANI, DALLAS, TX:
4,116,630, PUB. 1-10-2012. INT. CL. 35.
REDDOCH, HEATHER WELLS, LAKE CHARLES, LA:
2,509,819. REN. 2-17-12. INT. CL. 14.
REDSKY MOBILITY SOLUTIONS, LLC, WASHINGTON, DC:
4,117,898, PUB. 1-10-2012. MULTIPLE CLASS, INT. CLS. 35 AND 42.
REDSTONE COMPANIES HOSPITALITY, LLC, HOUSTON, TX:
4,118,256, PUB. 1-10-2012. INT. CL. 35.
4,118,257, PUB. 1-10-2012. INT. CL. 35.
REDSTONE FEDERAL CREDIT UNION, HUNTSVILLE, AL:
4,118,693, PUB. 1-10-2012. INT. CL. 36.
4,118,694, PUB. 1-10-2012. INT. CL. 36.
REED ELSEVIER PROPERTIES INC., WILMINGTON, DE:
4,119,723, INT. CL. 41.
REED, KYM, PALO ALTO, CA:
4,119,003, INT. CL. 25.
REEL BIOGRAPHY, INC., NEW YORK CITY, NY:
2,968,198, CANC. INT. CL. 41.
REEL FX, INC., DALLAS, TX:
4,118,779, INT. CL. 41.
REGAN, LARA JO, ALTADENA, CA:
4,118,105, PUB. 1-10-2012. INT. CL. 16.
REGINALD ABRAHAM SOETANTO, SPRING, TX:
4,117,922, PUB. 1-10-2012. MULTIPLE CLASS, INT. CLS. 35, 37 AND 42.
REGULATORY AFFAIRS PROFESSIONALS SOCIETY, ROCKVILLE, MD:
2,519,491. REN. 2-17-12. MULTIPLE CLASS, INT. CLS. 16, 41 AND 42.
REIGN DIGITAL CREATIVES LIMITED, HONG KONG, HONG KONG:
4,118,198, PUB. 1-10-2012. INT. CL. 9.
REILLY, SHANE, SAN FRANCISCO, CA:
4,117,161, PUB. 1-10-2012. INT. CL. 42.
REISCHMAN, CHARLES J., AKRON, OH:
2,467,729, CANC. INT. CL. 41.
REITZEL (SUISSE) SA, 1860 AIGLE, SWITZERLAND:
2,468,116, CANC. INT. CL. 29.
RELAXING NOTE LLC, RED LION, PA:
4,118,014, PUB. 1-10-2012. INT. CL. 44.
RELIANCE SOFTWARE SYSTEMS, INC., FARMINGTON HILLS, MI:
2,967,523, CANC. INT. CL. 9.
RELIANT ENERGY RETAIL HOLDINGS, LLC, HOUSTON, TX:
4,119,698, MULTIPLE CLASS, INT. CLS. 35 AND 42.
RELIEF POD INTERNATIONAL, LLC, SANTA ANA, CA:
4,116,911, PUB. 1-10-2012. MULTIPLE CLASS, INT. CLS. 5 AND 9.
4,116,912, PUB. 1-10-2012. MULTIPLE CLASS, INT. CLS. 5 AND 9.
REMINISME, LLC, SCOTTSDALE, AZ:
4,118,552, PUB. 1-10-2012. INT. CL. 38.
RENATA RIGHETTI, ITALY:
4,116,808, PUB. 1-10-2012. MULTIPLE CLASS, INT. CLS. 16, 41 AND 44.
RENOVO CORPORATION, NAPLES, FL:
4,117,769, PUB. 1-10-2012. INT. CL. 9.
RENTerval LLC, DALLAS, TX:
4,118,437, PUB. 1-10-2012. INT. CL. 35.
RENUKIN, LLC, GRAND RAPIDS, MI:
4,119,193, INT. CL. 3.
4,119,194, INT. CL. 3.
REPLICA CHICAGO INC, CHICAGO, IL:
4,118,551, PUB. 1-10-2012. INT. CL. 25.
REPUBLIC CLOTHING CORPORATION, NEW YORK, NY:
2,467,911, CANC. INT. CL. 25.
REPUMETRIX INC., TORONTO, ONTARIO, CANADA:
4,116,991, PUB. 1-10-2012. INT. CL. 42.
RESORT PROPERTY HOLDING, LLC, ST. LOUIS, MO:
4,118,164, PUB. 1-10-2012. INT. CL. 44.
RETAIL INNOVATION GROUP INC., PORTLAND, OR:
4,117,106, PUB. 1-10-2012. INT. CL. 35.
RETIREMENT ENGINEERING, INC., BOSTON, MA:
2,967,633, CANC. MULTIPLE CLASS, INT. CLS. 35 AND 36.
2,967,634, CANC. MULTIPLE CLASS, INT. CLS. 35 AND 36.
RETRACTABLE TECHNOLOGIES, INC., LITTLE ELM, TX:
4,119,619, INT. CL. 10.
REVELL-MONOGRAM, LLC, ELK GROVE VILLAGE, IL TO REVELL-MONOGRAM, LLC, ELK GROVE VILLAGE, IL:
2,468,456, CANC. INT. CL. 28.
REVELL-MONOGRAM, LLC, ELK GROVE VILLAGE, IL:
2,967,587, CANC. INT. CL. 28.
REVERE SECURITY CORPORATION, ADDISON, TX:
4,118,924, INT. CL. 45.
REVISION3 CORPORATION, SAN FRANCISCO, CA:
4,118,570, PUB. 1-10-2012. MULTIPLE CLASS, INT. CLS. 38 AND 41.
REVIVE MEDIA SOLUTIONS, INC., LEAWOOD, KS, DBA COUPONCOCKTAIL.COM:
4,118,216, PUB. 1-10-2012. INT. CL. 35.
REVMAN INTERNATIONAL, INC., NEW YORK, NY:
4,118,740, PUB. 1-10-2012. INT. CL. 20.
REVMAN INTRNATIONAL, INC., NEW YORK, NY:
4,118,741, PUB. 1-10-2012. INT. CL. 24.
REVOLUTION ANALYTICS, INC., PALO ALTO, CA:
2,968,601, CANC. INT. CL. 9.
REVOLUTION D, LLC, HILTON HEAD ISLAND, SC:
2,967,671, CANC. INT. CL. 42.
REVOLUTIONARY SOY, BELMORE NSW 2192, AUSTRALIA:
2,966,199, CANC. INT. CL. 30.
REVOLUTIONARY TECHNOLOGY NUTRITION, LLC, EDISON, NJ:
2,968,676, CANC. INT. CL. 5.
REXNORD INDUSTRIES, LLC, MILWAUKEE, WI:
2,518,346, REN. 2-22-12. INT. CL. 7.
REYNOLDS INNOVATIONS INC., WINSTON-SALEM, NC:
2,620,063, REN. 2-21-12. INT. CL. 34.
REZNIK, ALEX, NEW YORK, NY:
2,467,703, CANC. INT. CL. 41.
RFB ENTERTAINMENT, INC., FREEPORT, NY, DBA HUDSON & MCCOY:
2,467,649, CANC. INT. CL. 42.
RICARDO ARJONA, NEW YORK, NY:
4,118,790, INT. CL. 9.
RICCI, JOE, NEW RIVER, AZ:
4,117,395, PUB. 1-10-2012. INT. CL. 25.
RICHARD A. WALKER, ALPHARETTA, GA:
4,119,471, INT. CL. 35.
RICHARD D. WARREN, RANCHO SANTA MARGARITA, CA:
4,119,133, MULTIPLE CLASS, INT. CLS. 9, 16, 41 AND 45.
RICHARD FERRO, VAN NUYS, CA, DBA AMERICAN RIFLE DEPOT (ARD):
4,117,689, PUB. 1-10-2012. INT. CL. 35.
RICHARD HILFIGER, NEW YORK, NY:
4,117,380, PUB. 1-10-2012. MULTIPLE CLASS, INT. CLS. 9 AND 41.
RICHARD RAVID INC., ROYAL OAK, MI:
2,504,288, REN. 2-17-12. INT. CL. 3.
2,506,612, REN. 2-17-12. INT. CL. 3.
RICHARD, RON, SLIDELL, LA:
4,117,761, PUB. 1-10-2012. INT. CL. 35.

RICHEMONT INTERNATIONAL SA, VILLARS-SUR-GLANE, SWITZERLAND:
2,464,407. REN. 2-23-12. INT. CL. 14.

RICHEMONT INTERNATIONAL SA, SWITZERLAND:
4,116,813, PUB. 1-10-2012. INT. CL. 14.

RICHLINE GROUP, INC., NEW YORK, NY:
2,527,344. REN. 2-23-12. INT. CL. 14.

RICHPower INDUSTRIES, INC., WILLIAMSTON, SC:
4,119,833, INT. CL. 7.

RICOH COMPANY, LTD., OHTA-KU, TOKYO, JAPAN:
4,118,767, MULTIPLE CLASS, INT. CLS. 35 AND 42.

RIDDLE, EVELYN, BURBANK, CA:
4,117,853, PUB. 1-10-2012. INT. CL. 25.

RIDENOUR, BRENDAN ROSS, NOBLESVILLE, IN, DBA THOUGHT HAVEN:
4,118,050, PUB. 1-10-2012. INT. CL. 41.

RIDGE DIAGNOSTICS, INC., SAN DIEGO, CA:
4,117,317, PUB. 1-10-2012. INT. CL. 44.
4,117,318, PUB. 1-10-2012. INT. CL. 44.

RIDGEWAY OUTDOORS, INC., CATULA, GA:
4,117,572, PUB. 1-10-2012. INT. CL. 35.

RIDLEY BLOCK OPERATIONS, INC., MANKATO, MN:
4,119,285, INT. CL. 1.

RIGHTOFTHE DOT, LLC, POMPANO BEACH, FL, AKA RIGHT OF THE DOT:
4,117,501, PUB. 1-10-2012. MULTIPLE CLASS, INT. CLS. 35 AND 36.

RILEY WEISS, INC., PORTLAND, OR:
4,117,514, PUB. 1-10-2012. INT. CL. 35.

RIMA SATER, LLC, LA JOLLA, CA, DBA RIMA SATER:
4,117,674, PUB. 1-10-2012. MULTIPLE CLASS, INT. CLS. 14 AND 35.

RIO, ADRIAN NORMAN, BUENOS AIRES, ARGENTINA:
4,117,508, PUB. 1-10-2012. INT. CL. 33.

RIPE DESIGN INC, MANHATTAN BEACH, CA:
4,119,740, INT. CL. 30.

RIPKIN BASEBALL, INC., BALTIMORE, MD:
2,467,395, CANC. INT. CL. 41.

RIPTIDE S.R.L., ITALY:
4,116,681, PUB. 1-10-2012. MULTIPLE CLASS, INT. CLS. 9, 16, 25, 35, 38 AND 41.

RISK MANAGEMENT SOLUTIONS, INC., NEWARK, CA:
4,117,256, PUB. 12-6-2011. INT. CL. 36.

RITE-HITE HOLDING CORPORATION, MILWAUKEE, WI:
2,529,166. REN. 2-22-12. INT. CL. 11.

RITTAL GMBH & CO. KG, D-35745 HERBORN, FED REP GERMANY:
2,967,504, CANC. MULTIPLE CLASS, INT. CLS. 9, 11 AND 42.

RIVERS, KYLE E, FRAMINGHAM, MA:
4,118,130, PUB. 1-10-2012. INT. CL. 42.

RIVERWOOD SOLUTIONS LLC, MENLO PARK, CA:
4,117,196, PUB. 1-10-2012. INT. CL. 35.

RIVET SYSTEMS INCORPORATED, NORTH ANDOVER, MA:
4,118,064, PUB. 1-10-2012. INT. CL. 42.

RLS LIGHTING INC, HALLANDALE BEACH, FL:
4,116,559, PUB. 1-10-2012. INT. CL. 11.

RNG INTERNATIONAL EDUCATIONAL CONSULTANTS, LLC, FAIRFAX, VA:
4,117,022, PUB. 1-10-2012. MULTIPLE CLASS, INT. CLS. 9, 16, 36 AND 41.
4,117,023, PUB. 1-10-2012. MULTIPLE CLASS, INT. CLS. 9, 16, 36 AND 41.
4,117,024, PUB. 1-10-2012. MULTIPLE CLASS, INT. CLS. 9, 16, 36 AND 41.

ROB HALFORD ENTERTAINMENT LIMITED, LONDON, UNITED KINGDOM:
2,967,328, CANC. INT. CL. 41.

ROBB, LINDA, HALEIWA, HI:
2,967,579, CANC. MULTIPLE CLASS, INT. CLS. 9, 18 AND 28.

ROBERT BROMFIELD, MASSAPEQUA, NY:
4,117,883, PUB. 1-10-2012. INT. CL. 41.

ROBERT WOOD JOHNSON FOUNDATION, THE, PRINCETON, NJ:
2,621,016. REN. 2-21-12. INT. CL. 36.

ROBERTO CAVALLI S.P.A., MILANO, ITALY:
2,539,065. REN. 2-21-12. INT. CL. 18.

ROBERTSON, MARK, NEWPORT BEACH, CA:
4,118,163, PUB. 1-10-2012. INT. CL. 35.

ROBIN'S NEST MOBILE DIAGNOSTICS, LLC, ORLANDO, FL:
4,117,112, PUB. 1-10-2012. INT. CL. 44.

ROBINSON RANCH GOLF, L.P., SANTA CLARITA, CA:
2,468,208, CANC. MULTIPLE CLASS, INT. CLS. 24, 25, 28, 37 AND 41.

ROCHESTER ART SUPPLY INC, ROCHESTER, NY, DBA ENKAUSTIKOS WAX ART SUPPLIES:
4,119,318, INT. CL. 2.

ROCK BOTTOM RESTAURANTS, INC., LOUISVILLE, CO:
1,190,244. REN. 2-22-12. INT. CL. 42.

ROCK CREEK ATHLETICS, INC., GRINNELL, IA:
1,185,868. REN. 2-22-12. INT. CL. 25.
1,650,822. REN. 2-22-12. INT. CL. 25.

ROCK CREEK PIZZA DOUGH CO., SUPERIOR, CO:
4,117,987, PUB. 1-10-2012. INT. CL. 43.

ROCKCONCEPTS, INC., UPPER HOLLAND, PA:
4,118,513, PUB. 1-10-2012. INT. CL. 12.

ROCKET USA, LLC, ST. CHARLES, IL:
2,967,921, CANC. INT. CL. 28.

ROCKETTOWN OF MIDDLE TENNESSEE, INC., NASHVILLE, TN:
4,117,751, PUB. 1-10-2012. INT. CL. 41.

ROCKFORD CORPORATION, TEMPE, AZ:
2,630,917. REN. 2-23-12. INT. CL. 25.

ROCKWELL MEDICAL TECHNOLOGIES, INC., WIXOM, MI:
2,554,474. REN. 2-17-12. INT. CL. 5.
2,560,799. REN. 2-17-12. MULTIPLE CLASS, INT. CLS. 5 AND 10.

ROCKWOOL B.V., ROERMOND, NETHERLANDS:
1,659,752. REN. 2-21-12. INT. CL. 17.

ROCKY BRANDS, INC., NELSONVILLE, OH:
2,967,416, CANC. INT. CL. 25.

ROCKY MOUNTAIN ATV, INC., PAYSON, UT:
4,116,957, PUB. 1-10-2012. INT. CL. 12.

ROCKY MOUNTAIN JUNIOR GOLF TOUR INC., MONUMENT, CO:
4,117,276, PUB. 1-10-2012. INT. CL. 41.

ROCKY ROCOCO CORPORATION, OCONOMOWOC, WI:
1,186,029. REN. 2-22-12. MULTIPLE CLASS, INT. CLS. 30 AND 42.

RODEO EQUITIES INC., KELOWNA, CANADA:
2,965,523, CANC. INT. CL. 5.

RODGERS III, JOSEPH, LOS GATOS, CA:
4,116,980, PUB. 1-10-2012. INT. CL. 42.

RODNEY HUNT COMPANY, INC., ORANGE, MA, RODNEY HUNT COMPANY, ORANGE, MA:
1,690,051. REN. 2-22-12. INT. CL. 11.

RODRICK, SCOTT I., SAN FRANCISCO, CA AND SCHWARTZ, JOHN J., SAN FRANCISCO, CA:
2,968,584, CANC. INT. CL. 3.

ROGACKI, ZENON A., NORTH HOLLYWOOD, CA:
4,118,762, INT. CL. 14.

ROGERS, DANIEL A., SAN ANTONIO, TX:
4,117,873, PUB. 1-10-2012. MULTIPLE CLASS, INT. CLS. 35 AND 42.

ROHM AND HAAS CHEMICALS LLC, PHILADELPHIA, PA, MORTON INTERNATIONAL, INC., CHICAGO, IL:
1,704,503. REN. 2-21-12. INT. CL. 4.

ROHM AND HAAS COMPANY, PHILADELPHIA, PA:
1,185,314. REN. 2-22-12. INT. CL. 1.
1,186,259. REN. 2-22-12. INT. CL. 1.
1,697,263. REN. 2-21-12. INT. CL. 1.

ROHM AND HAAS COMPANY, PHILADELPIA, PA, SHIPLEY COMPANY INC., NEWTON, MA:
1,706,111. REN. 2-22-12. INT. CL. 1.

ROLDEN TRUST, DURBAN, KWA ZULU NATAL, SOUTH AFRICA:
4,118,949, INT. CL. 25.

ROLFES, JUDD, CLARKDALE, AZ:
4,119,372, INT. CL. 25.

- ROLLING MEADOWS BREWERY LLC, CANTRALL, IL,
AKA ROLLING MEADOWS BREWERY:
4,119,331, INT. CL. 32.
- ROLLINS, LESLEY K., STUDIO CITY, CA:
2,968,148, CANC. INT. CL. 25.
- ROMER, BARBARA C., NEW YORK, NY:
2,967,448, CANC. INT. CL. 41.
- RONALD A. JOHNSON, EFFINGHAM, IL:
2,967,515, CANC. INT. CL. 9.
- RONALD D. BURNETT, NEWPORT NEWS, VA:
4,119,689, INT. CL. 28.
- RONALD ERNEST BROOKS, GRINDLEFORD, UNITED
KINGDOM:
392,752, REN. 2-21-12. U.S. CL. 23 (INT. CL. 8).
- RONALD ROBERTS, EAGLEVILLE, PA:
4,119,114, INT. CL. 8.
- RONNOCO COFFEE COMPANY, ST. LOUIS, MO:
1,708,501, REN. 2-21-12. INT. CL. 30.
- ROOFING & RESTORATION SERVICES OF AMERICA,
LLC, WAXAHACHIE, TX:
4,119,598, INT. CL. 37.
- ROOT, BRIAN D., TEMPERANCE, MI:
4,119,468, INT. CL. 9.
- ROSEN HOTELS AND RESORTS, INC., ORLANDO, FL:
4,119,658, INT. CL. 41.
- ROSENBERG, JOTHY, AUBURNDALE, MA, DBA WHO
SAYS I CAN'T:
4,117,570, PUB. 1-10-2012. INT. CL. 25.
- ROSENTRER, JENNIFER JAMES, CHEYENNE, WY:
4,119,111, MULTIPLE CLASS, INT. CLS. 25 AND 41.
- ROSKO FASTENERS & SUPPLY, INC., WOODSTOCK, GA:
2,548,753, REN. 2-23-12. INT. CL. 6.
- ROTARY INTERNATIONAL, EVANSTON, IL:
2,547,385, REN. 2-23-12. INT. CL. 25.
- ROTONDO WEIRICH ENTERPRISES, INC., LEDERACH,
PA:
4,117,051, PUB. 1-10-2012. INT. CL. 37.
- ROUILLARD, WENDY W., NANTUCKET, MA:
2,466,904, CANC. INT. CL. 28.
- ROWDEN, BRIAN SCOTT, WEST OLIVE, MI AND ROW-
DEN, KATIE MARIE, WEST OLIVE, MI:
2,967,781, CANC. INT. CL. 41.
- ROWENTA-WERKE GMBH, OFFENBACH A.M., FED REP
GERMANY:
2,967,341, CANC. INT. CL. 9.
- ROWLEY BROTHERS, INC., BAY CITY, MI:
4,118,809, MULTIPLE CLASS, INT. CLS. 1, 2, 3, 4, 16 AND
37.
- ROYAL BLUE SERVICES LLC, ST. PETERSBURG, FL:
4,118,052, PUB. 1-10-2012. INT. CL. 37.
- ROYAL CREST DAIRY, INC., DENVER, CO:
1,748,672, REN. 2-21-12. INT. CL. 29.
- ROYAL INNOVATIONS, LLC, MERIDIAN, ID:
4,117,536, PUB. 1-10-2012. INT. CL. 10.
- ROYAL NATIONAL INSTITUTE OF BLIND PEOPLE, LON-
DON, UNITED KINGDOM:
4,119,754, INT. CL. 9.
- ROYAL OAK ENTERPRISES, LLC, ROSWELL, GA:
4,119,685, INT. CL. 4.
- ROYAL PEST CONTROL INC., RIO VERDE, AZ:
4,117,916, PUB. 1-10-2012. INT. CL. 37.
- ROYAL WINE CORPORATION, BAYONNE, NJ:
4,117,402, PUB. 1-10-2012. INT. CL. 33.
- ROZZI, CHRISTOPHER, NEW YORK, NY:
4,118,243, PUB. 1-10-2012. INT. CL. 16.
- RPG DIFFUSOR SYSTEMS, INC., UPPER MARLBORO, MD:
1,650,166, REN. 2-22-12. INT. CL. 19.
- RT&H, INC., ANAHEIM, CA:
4,117,097, PUB. 1-10-2012. INT. CL. 36.
- RTKL ASSOCIATES, INC., BALTIMORE, MD:
4,118,615, PUB. 1-10-2012. INT. CL. 42.
- RTM SPORTS, LLC, RALEIGH, NC:
2,468,414, CANC. INT. CL. 42.
- RUBBERMAID COMMERCIAL PRODUCTS LLC, ATLAN-
TA, GA, RUBBERMAID COMMERCIAL PRODUCTS
INC., WINCHESTER, VA:
1,184,813, REN. 2-22-12. INT. CL. 20.
- RUG DOCTOR, INC., PLANO, TX:
2,536,671, REN. 2-21-12. INT. CL. 37.
4,119,309, MULTIPLE CLASS, INT. CLS. 7 AND 37.
- RUNOWICH, VINCENT P. SR., ST PETERSBURG, FL:
2,466,985, CANC. INT. CL. 19.
- RUNZHEIMER INTERNATIONAL LTD., WATERFORD,
WI:
4,117,357, PUB. 1-10-2012. MULTIPLE CLASS, INT. CLS. 9
AND 42.
- RUTHLESS ENTERTAINMENT PTE LTD, SINGAPORE,
SINGAPORE:
4,119,726, MULTIPLE CLASS, INT. CLS. 9 AND 45.
- RWN MANAGEMENT LLC, NEW YORK, NY:
4,119,006, INT. CL. 36.
- RYAN, PATRICK CLARKSON, NEWPORT, RI:
4,119,090, INT. CL. 21.
- S & S INNOVATIONS, INC., WEST DES MOINES, IA:
2,968,639, CANC. INT. CL. 28.
- S. C. JOHNSON & SON, INC., RACINE, WI:
1,726,974, REN. 2-21-12. INT. CL. 5.
2,968,499, CANC. INT. CL. 3.
4,119,399, MULTIPLE CLASS, INT. CLS. 4 AND 5.
- S. D. MYERS, INC., TALLMADGE, OH:
4,117,823, PUB. 1-10-2012. INT. CL. 9.
- S. TOUS, S.L., MANRESA, SPAIN:
4,117,129, PUB. 1-10-2012. INT. CL. 3.
- S.A. ARMSTRONG LIMITED, SCARBOROUGH, ONTARIO,
CANADA:
2,524,700, REN. 2-21-12. INT. CL. 9.
- S.C. JOHNSON & SON, INC., RACINE, WI, DRACKETT
COMPANY, THE, CINCINNATI, OH:
399,245, REN. 2-17-12. U.S. CL. 6 (INT. CL. 1).
- S.C.P 3 MAD MEN, MC-98000 MONACO, MONACO:
4,116,845, PUB. 1-10-2012. MULTIPLE CLASS, INT. CLS.
12, 25 AND 41.
- S.P. INTERNATIONAL, INC., DALLAS, TX:
2,967,408, CANC. MULTIPLE CLASS, INT. CLS. 10, 14
AND 28.
- S&R DISTRIBUTION COMPANY, INC., LOS ANGELES, CA:
4,118,038, PUB. 1-10-2012. INT. CL. 25.
- SAAHIL DENTAL P.C., FLUSHING, NY, DBA PREFERRED
DENTAL CARE:
4,117,076, PUB. 1-10-2012. INT. CL. 44.
- SABER INDUSTRIES INC., WINNIPEG, MANITOBA, CA-
NADA:
4,117,811, PUB. 1-10-2012. INT. CL. 19.
- SADOFF, MITCHELL, STILLWATER, MN, DBA MITCH-
ELL'S CHEESECAKES:
4,117,924, PUB. 1-10-2012. INT. CL. 30.
- SAEDI, SAMAN, BEVERLY HILLS, CA:
4,119,382, INT. CL. 25.
- SAF-HOLLAND EQUIPMENT LIMITED, NORWICH, ON-
TARIO, CANADA:
2,658,085, REN. 2-22-12. INT. CL. 8.
- SAFE TV SHOP, LLC, CHARLOTTE, NC:
4,119,609, INT. CL. 21.
- SAFETYLINE, INC., PRIEST RIVER, ID:
2,393,273, CANC. INT. CL. 35.
- SAGE, DUSTIN, DUNKERTON, IA:
4,117,989, PUB. 1-10-2012. INT. CL. 44.
- SAGEPRESENCE, LLC, ST. PAUL, MN:
4,118,709, PUB. 1-10-2012. INT. CL. 41.
- SAHAJANAND LIFE SCIENCES, INC., BETHESDA, MD:
4,118,202, PUB. 1-10-2012. INT. CL. 5.
- SAINT MARY'S HOME OF ERIE, ERIE, PA:
4,117,944, PUB. 1-10-2012. INT. CL. 44.
- SAINT-GOBAIN PERFORMANCE PLASTICS CORPORA-
TION, AURORA, OH:
926,062, REN. 2-21-12. U.S. CL. 5 (INT. CL. 17).
- SALCARE HOME HEALTH SERVICES, INC., NEW YORK,
NY:
4,118,855, INT. CL. 44.
- SALE SIGNAL, LLC, LEHI, UT:
4,118,559, PUB. 1-10-2012. INT. CL. 42.
- SALES ANALYTICS, INC., MORGAN HILL, CA:
4,117,364, PUB. 1-10-2012. INT. CL. 35.
- SALESFORCE.COM, INC., SAN FRANCISCO, CA:
4,119,346, INT. CL. 41.

SALON COMMODITIES, INC., MELROSE PARK, IL:
4,119,333, INT. CL. 3.

SALONQUEST, LLC, CHAGRIN FALLS, OH:
4,119,505, INT. CL. 3.

SALONS ONLY, INC., VISTA, CA:
2,967,586, CANC. INT. CL. 3.

SALVADOR SAPENA, S.L., 03600 ELDA, ALICANTE, SPAIN:
2,967,703, CANC. INT. CL. 25.

SAM 3X ENGINEERING, MONACO:
4,116,779, PUB. 1-10-2012. INT. CL. 17.

SAMSUNG ELECTRONICS CO., LTD., SUWON-SI,
GYEONGGI-DO, REPUBLIC OF KOREA:
2,965,637, CANC. INT. CL. 9.
4,118,868, INT. CL. 9.
4,119,109, INT. CL. 11.

SAN DIEGO CONVENTION AND TOURIST BUREAU, SAN
DIEGO, CA, DBA SAN DIEGO CONVENTION AND
VISITORS BUREAU:
4,118,483, PUB. 1-10-2012. INT. CL. 35.
4,118,484, PUB. 1-10-2012. INT. CL. 35.

SAN DIEGO COUNTY APARTMENT ASSOCIATION, SAN
DIEGO, CA:
2,615,082, REN. 2-17-12. INT. CL. 42.

SAN FRANCIS IMPORTS, INC., GLENDALE, CA:
4,117,947, PUB. 1-10-2012. INT. CL. 35.

SAN FRANCISCO ART INSTITUTE, SAN FRANCISCO, CA:
4,118,556, PUB. 1-10-2012. INT. CL. 41.

SAN FRANCISCO MARATHON, INC., SAN FRANCISCO,
CA:
4,117,059, PUB. 1-10-2012. MULTIPLE CLASS, INT. CLS.
25 AND 41.

SAN PASQUAL CASINO DEVELOPMENT GROUP INC.,
VALLEY CENTER, CA:
4,119,104, INT. CL. 35.

SAN PEDRO FISH MARKET ENTERPRISES, INC., WIL-
MINGTON, CA:
4,118,197, PUB. 1-10-2012. INT. CL. 43.

SAN SHING FASTECH CORP., HSIANG, TAINAN HSIEN,
TAIWAN:
1,677,346, REN. 2-23-12. INT. CL. 6.

SAN SWISS ARMS AG, CH-8212 NEUHAUSEN AM RHEIN-
FALL, SWITZERLAND:
4,021,145, COR. MULTIPLE CLASS, INT. CLS. 13 AND
28.

SANBORN, MARJORIE L, COLOMA, CA:
4,118,032, PUB. 1-10-2012. INT. CL. 31.

SANCHEZ, ANTONIO, HUNTINGTON BEACH, CA:
2,464,778, REN. 2-23-12. INT. CL. 25.

SANCHEZ, GUADALUPE, BAKERSFIELD, CA:
4,118,281, PUB. 1-10-2012. INT. CL. 36.

SANCILIO AND COMPANY, INC., RIVIERA BEACH, FL:
4,118,488, PUB. 1-10-2012. INT. CL. 5.

SANDBOX.COM, INC., FAIRFAX, VA:
2,468,395, CANC. INT. CL. 41.

SANDLER'S GIFT BASKETS OF DISTINCTION, INC.,
FLORAL PARK, NY:
4,117,640, PUB. 1-10-2012. INT. CL. 30.
4,117,641, PUB. 1-10-2012. INT. CL. 35.

SANES, HEIDI, DELRAY BEACH, FL:
4,119,342, INT. CL. 45.

SANFORD BRYANT COMPANY, NEW YORK, NY:
2,967,905, CANC. INT. CL. 25.

SANIBEL/CAPTIVA TRUST COMPANY, SANIBEL ISLAND,
FL:
4,118,136, PUB. 1-10-2012. INT. CL. 36.

SANOFI, FRANCE:
4,116,735, PUB. 1-10-2012. MULTIPLE CLASS, INT. CLS.
5, 16, 35, 38, 41 AND 44.

SANOFI PASTEUR VAXDESIGN CORPORATION, WIL-
MINGTON, DE:
4,118,814, INT. CL. 42.

SANTA CLAUSET TOYS LC, SOUTH JORDAN, UT:
4,117,396, PUB. 1-10-2012. MULTIPLE CLASS, INT. CLS.
16 AND 28.
4,117,412, PUB. 1-10-2012. MULTIPLE CLASS, INT. CLS.
16 AND 28.
4,117,413, PUB. 1-10-2012. MULTIPLE CLASS, INT. CLS.
16 AND 28.

SANTA MONICA CHOCOLATE COMPANY, LLC, SANTA
MONICA, CA:
4,119,292, INT. CL. 30.

SANY GROUP CO., LTD., CHINA:
4,116,868, PUB. 1-10-2012. INT. CL. 12.

SAPP BROS., INC., OMAHA, NE:
4,118,282, PUB. 1-10-2012. MULTIPLE CLASS, INT. CLS. 1
AND 4.

SAPPORO HOLDINGS LIMITED, SHIBUYA-KU, TOKYO,
JAPAN, SAPPORO BREWERIES LIMITED, CHOU-KU,
TOKYO, JAPAN AND TOYO SEIKAN KAISHA, LTD.,
CHIYODA-KU, TOKYO, JAPAN:
1,670,439, REN. 2-21-12. INT. CL. 32.

SARANTAKOS, CHRISTOPHER, WOODBURY, NY, AKA
CRISS ANGEL:
4,119,415, INT. CL. 41.

SARGENT MANUFACTURING COMPANY, NEW HAVEN,
CT:
4,117,858, PUB. 1-10-2012. INT. CL. 6.

SARPONG, JUNE, ALTADENA, CA:
4,119,242, INT. CL. 38.

SARYAN CORPORATION, CHICAGO, IL:
4,118,865, INT. CL. 9.

SASHA V. SOUZA, NAPA, CA, DBA SASHA SOUZA
EVENTS:
4,117,307, PUB. 1-10-2012. INT. CL. 41.

SASSA BELLA, HARRODSBURG, KY, DBA SASSA BELLA:
4,117,835, PUB. 1-10-2012. INT. CL. 3.

SAVE-A-LOT FOOD STORES, LTD., EARTH CITY, MO:
2,968,172, CANC. INT. CL. 35.

SAVENSEAL.COM LTD, NEVADA CITY, CA:
4,118,327, PUB. 1-10-2012. INT. CL. 16.

SAVING SENSE MEDIA, LLC, PHOENIX, AZ:
4,117,874, PUB. 1-10-2012. MULTIPLE CLASS, INT. CLS.
35 AND 36.

SAVORY ADDICTIONS, LLC, LEE'S SUMMIT, MO:
4,117,999, PUB. 1-10-2012. INT. CL. 29.

SAYLOR, RONALD, BAKERSFIELD, CA:
4,118,265, PUB. 1-10-2012. INT. CL. 41.

SBH, LLC, MEMPHIS, TN:
4,119,861, INT. CL. 43.

SCAFIDEL, B. J., MAGNOLIA, MS:
2,968,323, CANC. INT. CL. 28.

SCANLAN INTERNATIONAL, INC., ST. PAUL, MN:
1,670,151, REN. 2-22-12. INT. CL. 10.

SCAPA GROUP PLC, BLACKBURN, LANCASHIRE, UNI-
TED KINGDOM:
2,968,141, CANC. INT. CL. 17.

SCAPE SIGNS, LTD., SCOTTSDALE, AZ:
4,119,267, INT. CL. 6.

SCENTSHOTS, LLC, KATONAH, NY:
4,119,199, INT. CL. 3.
4,119,200, INT. CL. 3.
4,119,201, INT. CL. 3.

SCHAEFFER MFG. CO., ST. LOUIS, MO:
4,118,474, PUB. 1-10-2012. INT. CL. 1.

SCHENCK PROCESS GMBH, FED REP GERMANY AND
CARL SCHENCK AG, FED REP GERMANY:
4,014,452, COR. MULTIPLE CLASS, INT. CLS. 6, 7, 9, 11,
12, 20 AND 42.

SCHILL + SEILACHER GMBH, FED REP GERMANY:
4,116,828, PUB. 1-10-2012. INT. CL. 1.

SCHIPPER & COMPANY U.S.A., INC., BRIDGEPORT, CT:
4,117,349, PUB. 1-10-2012. INT. CL. 31.

SCHLUMBERGER TECHNOLOGY CORPORATION, HOUS-
TON, TX:
4,118,262, PUB. 1-10-2012. INT. CL. 9.

SCHLUMBERGER WATER SERVICES (NETHERLANDS)
B.V., DELFT, NETHERLANDS:
4,117,104, PUB. 1-10-2012. INT. CL. 9.

SCHMITT MEASUREMENT SYSTEMS, INC., PORTLAND,
OR:
4,117,865, PUB. 1-10-2012. INT. CL. 9.
4,117,876, PUB. 1-10-2012. INT. CL. 9.

SCHNAL, ADAM, SAN FRANCISCO, CA:
2,468,492, CANC. INT. CL. 42.

SCHOLARBUYS LLC, CARPENTERSVILLE, IL:
4,117,078, PUB. 1-10-2012. MULTIPLE CLASS, INT. CLS.

- 35 AND 41.
SCHOLASTIC INC., NEW YORK, NY, CHILDRENS PRESS, INC., CHICAGO, IL:
1,734,024. REN. 2-22-12. INT. CL. 16.
SCHONBRUN, MICHAEL K., LOUISVILLE, CO:
2,467,137. CANC. INT. CL. 42.
SCHROEDER, DENNIS, PHOENIX, AZ:
4,117,123. PUB. 1-10-2012. INT. CL. 7.
SCHUBACH ENTERPRISES, INC., SCOTTSDALE, AZ:
4,119,544. INT. CL. 14.
SCHUHFABRIK DER KLEINE MUCK GMBH & CO. KG, FED REP GERMANY:
2,967,827. CANC. INT. CL. 25.
SCHULZ, TIM, PARKERSBURG, WV:
2,467,567. CANC. INT. CL. 42.
SCHURHAMMER JEWELRY, INC., WABASHA, MN:
2,748,385. COR. INT. CL. 14.
SCHWARZ PHARMA AG, D-40789, MONHEIM, FED REP GERMANY:
2,965,605. CANC. INT. CL. 5.
SCIENCE SPECTRUM, LUBBOCK, TX:
1,677,921. REN. 2-22-12. INT. CL. 41.
SCLC, INC., EVANSVILLE, IN:
4,118,366. PUB. 1-10-2012. INT. CL. 35.
SCOTSMAN CAPITAL MANAGEMENT LLC, NEW YORK, NY:
2,967,953. CANC. INT. CL. 36.
SCRAPROOM, LLC, GAINESVILLE, GA:
4,119,624. INT. CL. 9.
SCRIP WORLD, LLC, TAYLORSVILLE, UT, SCRIP WORLD, LLC, NORTH SALT LAKE, UT:
2,530,517. REN. 2-21-12. INT. CL. 36.
SCRUMWISE APS, FREDERIKSBERG C, DENMARK:
4,117,192. PUB. 1-10-2012. INT. CL. 42.
SDC SWEDENCARE AB, SWEDEN:
2,967,235.
SEA WORLD LLC, ORLANDO, FL:
1,181,571. REN. 2-21-12. INT. CL. 41.
1,684,584. REN. 2-22-12. INT. CL. 30.
SEABROOK WALLCOVERINGS, INC., MEMPHIS, TN:
2,968,162. CANC. INT. CL. 35.
SEAGULL BOOK & TAPE, INC., AMERICAN FORK, UT:
2,919,027. CANC. INT. CL. 35.
SEALANT EQUIPMENT & ENGINEERING, INC., PLYMOUTH, MI:
2,602,146. REN. 2-21-12. INT. CL. 9.
SEAN SCOTT, LA JOLLA, CA:
4,117,136. PUB. 1-10-2012. INT. CL. 16.
SEARS BRANDS, LLC, HOFFMAN ESTATES, IL:
1,179,644. REN. 2-22-12. INT. CL. 42.
1,179,644. AM. INT. CL. 42.
4,117,752. PUB. 1-10-2012. INT. CL. 42.
4,119,054. INT. CL. 25.
4,119,283. MULTIPLE CLASS, INT. CLS. 35 AND 41.
4,119,460. INT. CL. 28.
SEASONAL WHOLESALE LLC, ESCONDIDO, CA:
4,118,081. PUB. 1-10-2012. INT. CL. 35.
SEASUNS, MIAMI, FL:
4,116,609. PUB. 1-10-2012. INT. CL. 25.
SEATTLE GOURMET FOODS, INC., KENT, WA, BUCKEYE BEANS & HERBS, INC., SPOKANE, WA:
1,696,276. REN. 2-23-12. INT. CL. 29.
SEATTLE GOURMET FOODS, INC., KENT, WA:
2,468,250. CANC. INT. CL. 30.
SEBAGO USA, LLC, ROCKFORD, MI:
4,119,479. INT. CL. 35.
SECURE TRANSPORTATION COMPANY, INC., WHITTIER, CA:
4,118,466. PUB. 1-10-2012. INT. CL. 39.
SECURITIES AND COMMERCE INSTITUTE, LLC, MIAMI, FL:
4,119,824. INT. CL. 41.
SEDONA CORPORATION, KING OF PRUSSIA, PA:
2,967,355. CANC. MULTIPLE CLASS, INT. CLS. 9 AND 42.
SEEIDEAS, INC., MASON, OH:
2,571,058. REN. 2-21-12. INT. CL. 42.
SEEING SPOTS, INC., PORTLAND, OR:
2,467,687. CANC. INT. CL. 25.
SEGAL, JONATHAN, NEW YORK, NY:
2,967,632. CANC. INT. CL. 25.
SEGETIS, INC., GOLDEN VALLEY, MN:
4,119,371. INT. CL. 1.
SEGOOL-EARL, KIM, ALTA LOMA, CA AND FIGGUS, JAMES, ALTA LOMA, CA:
2,520,727. REN. 2-22-12. MULTIPLE CLASS, INT. CLS. 35 AND 37.
SEIKO INSTRUMENTS KABUSHIKI KAISHA, CHIBA 261-8507, JAPAN, TA SEIKO INSTRUMENTS INC.:
2,965,610. CANC. MULTIPLE CLASS, INT. CLS. 9, 14, 28 AND 38.
SEKISUI KINZOKU CO., LTD., SHINJUKU-KU, TOKYO, JAPAN:
1,678,674. REN. 2-21-12. INT. CL. 28.
SELDON YUAN, BROOKLYN, NY:
4,118,537. PUB. 1-10-2012. INT. CL. 18.
SELECT INTELLECTUAL, LLC, PITTSBURGH, PA:
4,119,718. INT. CL. 35.
SELLSTROM MANUFACTURING COMPANY, PALATINE, IL:
2,528,987. REN. 2-21-12. INT. CL. 9.
SELMAN AND ASSOCIATES, LTD., MIDLAND, TX:
4,117,232. PUB. 1-10-2012. INT. CL. 42.
4,117,489. PUB. 1-10-2012. INT. CL. 42.
SEMINIS VEGETABLE SEEDS, INC., OXNARD, CA:
4,117,714. PUB. 1-10-2012. INT. CL. 31.
SENMI EKISU CO., LTD., EHIME, JAPAN:
4,118,806. INT. CL. 1.
SENNINGER IRRIGATION INC., CLERMONT, FL:
4,116,586. PUB. 1-10-2012. INT. CL. 11.
SENSIENT FLAVORS LLC, INDIANAPOLIS, IN, FANTASY FLAVORS, INC., WHEATON, IL:
726,316. REN. 2-22-12. U.S. CL. 46 (INT. CLS. 1, 5, 29, 30, 31 AND 32).
SERACU LTD., LONDON SE18 3BY, UNITED KINGDOM, DBA RECALLADS.COM:
4,117,227. PUB. 1-10-2012. INT. CL. 35.
SEREBRENNIKOV, BORIS L., SHREWSBURY, MA:
4,119,373. INT. CL. 41.
SERGIO HAMERNIK, LOS ANGELES, CA:
4,117,032. PUB. 1-10-2012. MULTIPLE CLASS, INT. CLS. 9, 25 AND 37.
SERRALLES HOTEL, INC., PONCE, PUERTO RICO:
2,966,179. CANC. INT. CL. 25.
SERRANI, PATRICE, SANTA BARBARA, CA:
4,119,712. INT. CL. 31.
SERVE IT HEALTHY FOODSERVICE COMPANY, SPOKANE VALLEY, WA:
4,118,095. PUB. 1-10-2012. INT. CL. 30.
SERVICE EXPERTS LLC, RICHARDSON, TX:
4,119,664. INT. CL. 37.
SERVICE2CLIENT, LLC, DALLAS, TX:
2,966,230. CANC. MULTIPLE CLASS, INT. CLS. 36, 41 AND 42.
SETILI & ASSOCIATES, LLC, ATLANTA, GA:
4,119,778. INT. CL. 35.
SETTON INTERNATIONAL FOODS, INC., COMMACK, NY:
2,467,441. CANC. MULTIPLE CLASS, INT. CLS. 29, 30 AND 31.
SEVEN SEAS CRUISES S. DE R.L., PANAMA, PANAMA:
2,540,614. REN. 2-18-12. INT. CL. 39.
SEYMOUR MANUFACTURING CO., INC., SEYMOUR, IN:
2,536,629. REN. 2-22-12. INT. CL. 8.
SF INVESTMENTS, INC., WILMINGTON, DE:
926,962. REN. 2-17-12. U.S. CL. 46 (INT. CLS. 1, 5, 29, 30, 31 AND 32).
SF INVESTMENTS, INC., WILMINGTON, DE, FARMLAND INDUSTRIES, INC., KANSAS CITY, MO:
1,649,600. REN. 2-22-12. INT. CL. 29.
SFI FOUNDATION, INC., POWAY, CA:
4,117,821. PUB. 1-10-2012. INT. CL. 42.
SHAAIM FAMILY LLC, BROOKLYN, NY:
4,117,350. PUB. 1-10-2012. INT. CL. 41.
SHABLOW, KIRK, LOS ANGELES, CA:
4,116,606. PUB. 10-4-2011. MULTIPLE CLASS, INT. CLS.

- 9, 16 AND 41.
 SHAFFER, TODD, ESCONDIDO, CA:
 4,117,656, PUB. 1-10-2012. INT. CL. 42.
 SHAHRAM SALEMY, M.D., PLLC, SEATTLE, WA:
 4,117,414, PUB. 1-10-2012. INT. CL. 44.
 SHANDONG HENGFENG RUBBER & PLASTIC CO., LTD.,
 DONGYING SHANDONG, CHINA:
 4,119,163, INT. CL. 12.
 SHANGHAI CARESSING HOME PRODUCTS CO., LTD.,
 SHANGHAI, CHINA:
 4,119,623, INT. CL. 20.
 SHANGHAI EBEST COMMUNICATION & TECHNOLOGY
 CO., LTD., SHANGHAI CITY, CHINA:
 4,119,615, INT. CL. 9.
 SHANGHAI GUAN SHENG YUAN FOOD LTD., SHANG-
 HAI, CHINA, SHANGHAI GUAN SHENG YUAN FOOD
 GENERAL FACTORY, SHANGHAI, CHINA:
 1,733,373. REN. 2-17-12. INT. CL. 30.
 SHANGHAI LANSHENG CORPORATION, SHANGHAI,
 CHINA:
 2,662,878. REN. 2-23-12. INT. CL. 15.
 SHANGHAI SILIN SPECIAL EQUIPMENT CO., LTD.,
 SHANGHAI, CHINA:
 4,117,549, PUB. 1-10-2012. INT. CL. 9.
 SHANGHAI YIHAO CATERING COMPANY LIMITED,
 SHANGHAI CITY, CHINA:
 4,119,631, INT. CL. 43.
 SHAPIRO, JORDAN MARTIN, PEORIA, AZ, AKA JORDAN
 MARTIN:
 4,119,327, INT. CL. 9.
 SHAPPIE, TRISHA L., MURRIETA, CA, DBA TEACHERS N
 TOUCH:
 2,968,644, CANC. INT. CL. 16.
 SHAREHOLDERS BRANDS, LLC, TWO RIVERS, WI:
 4,118,058, PUB. 1-10-2012. INT. CL. 29.
 SHARON NAGASSAR DESIGNS LLC, MILFORD, PA:
 4,117,238, PUB. 1-10-2012. INT. CL. 42.
 SHARON YOUNG INC., DALLAS, TX:
 4,119,142, INT. CL. 25.
 SHARPE LINES, INC., CIRCLEVILLE, OH, DBA HEALTH
 CARE LOGISTICS, INC.:
 2,593,176, CANC. INT. CL. 10.
 SHCHEGOLEV, OLEG, ST. PETERSBURG 196600, RUSSIAN
 FED., DBA SEOQUAKE TEAM:
 4,117,491, PUB. 1-10-2012. MULTIPLE CLASS, INT. CLS. 9
 AND 35.
 SHEAR, WARREN K., CAMBRIDGE, MA:
 2,968,473, CANC. INT. CL. 44.
 2,968,554, CANC. INT. CL. 44.
 SHECHTER, PAGIEL, LOS ANGELES, CA AND SHECHTER,
 OFRA, LOS ANGELES, CA:
 4,117,839, PUB. 1-10-2012. MULTIPLE CLASS, INT. CLS. 5
 AND 16.
 SHEH FUNG SCREWS CO., LTD., KAOHSIUNG COUNTY
 82547, TAIWAN:
 1,679,162. REN. 2-21-12. INT. CL. 6.
 SHELDON INVESTMENT GROUP, INC., ALGONQUIN, IL,
 DBA SCAN AM COMPANY:
 4,116,969, PUB. 1-10-2012. INT. CL. 9.
 SHEPARD BROS., INC., LA HABRA, CA:
 2,537,581. REN. 2-22-12. INT. CL. 5.
 SHEPLERS, INC., WICHITA, KS:
 4,118,616, PUB. 1-10-2012. INT. CL. 35.
 SHERIDAN, PATRICK, LOS ANGELES, CA:
 4,119,167, INT. CL. 25.
 SHERRILL, INC., GREENSBORO, NC:
 4,117,687, PUB. 1-10-2012. INT. CL. 6.
 SHERRY'S KITCHEN LLC, PHOENIX, AZ:
 4,118,036, PUB. 1-10-2012. INT. CL. 30.
 SHERWOOD REALTY GROUP INC., BRANTFORD, ON-
 TARIO, CANADA, DBA RV PARTS PLUS:
 4,118,290, PUB. 1-10-2012. INT. CL. 9.
 SHERWOOD, THOMAS W., PENN'S PARK, PA:
 4,117,590, PUB. 1-10-2012. MULTIPLE CLASS, INT. CLS.
 25, 41 AND 43.
 SHIELD MFG. INC., TONAWANDA, NY:
 4,118,175, PUB. 1-10-2012. INT. CL. 28.
 SHINCO ELECTRONICS GROUP CO., LTD., CHANGZHOU,
 CHINA:
 2,968,357, CANC. INT. CL. 9.
 SHIPLEY GROUP, L.P., YORK, PA:
 4,119,440, MULTIPLE CLASS, INT. CLS. 35, 36, 37 AND
 39.
 SHIPPERT ENTERPRISES, LTD., CENTENNIAL, CO:
 2,467,746, CANC. INT. CL. 10.
 SHIRE HUMAN GENETIC THERAPIES, INC., LEXINGTON,
 MA:
 4,119,043, INT. CL. 9.
 SHOCK MANSION PTY LTD, AUSTRALIA:
 4,116,699, PUB. 1-10-2012. INT. CL. 25.
 SHOE LOVES ME, WOODHAVEN, NY:
 4,117,140, PUB. 1-10-2012. INT. CL. 25.
 SHOE SHOW, INC., CONCORD, NC:
 1,670,841. REN. 2-21-12. INT. CL. 25.
 SHOP-VAC CORPORATION, WILLIAMSPORT, PA:
 1,157,925. REN. 2-17-12. INT. CL. 9.
 SHOUT MOUNTAIN, CRANBERRY TWP, PA:
 4,119,565, MULTIPLE CLASS, INT. CLS. 35, 41 AND 42.
 SHOWA DENKO K.K., TOKYO, JAPAN:
 2,624,033. REN. 2-21-12. INT. CL. 1.
 SHOWSTOPPERS, LLC, MANHATTAN BEACH, CA:
 4,118,591, PUB. 1-10-2012. INT. CL. 26.
 SHUERT INDUSTRIES SALES INC., STERLING HEIGHTS,
 MI:
 1,676,376. REN. 2-21-12. INT. CL. 20.
 SHUI T. LAI, PH.D., WINDERMERE, FL:
 4,118,801, INT. CL. 44.
 SHURE PRODUCTS INC., CHICAGO, IL:
 4,117,220, PUB. 1-10-2012. INT. CL. 28.
 SI O. RHEW, LOS ANGELES, CA:
 4,117,487, PUB. 1-10-2012. INT. CL. 25.
 SIEMENS AKTIENGESELLSCHAFT, MUNICH, FED REP
 GERMANY:
 2,968,083, CANC. INT. CL. 9.
 SIEMENS AKTIENGESELLSCHAFT, 80333 MÜNCHEN,
 FED REP GERMANY:
 4,116,851, PUB. 1-10-2012. INT. CL. 10.
 SIGMA-ALDRICH CO. LLC, ST. LOUIS, MO:
 4,118,665, PUB. 1-10-2012. INT. CL. 1.
 SIGN IT QUICK, INC., CHARLESTON, SC:
 2,656,073. REN. 2-21-12. MULTIPLE CLASS, INT. CLS. 35
 AND 42.
 SIGNATURE AIR, INC., NEW YORK, NY:
 2,968,040, CANC. MULTIPLE CLASS, INT. CLS. 36 AND
 39.
 SIGNATURE HEALTH PARTNERS, INC., VENTURA, CA:
 2,968,403, CANC. MULTIPLE CLASS, INT. CLS. 35 AND
 44.
 SIGNATURE MARKETING GROUP, LTD., FAIRFIELD, NJ:
 2,676,753. REN. 2-22-12. INT. CL. 11.
 SIKA AG, BARR, SWITZERLAND:
 4,117,880, PUB. 12-6-2011. MULTIPLE CLASS, INT. CLS. 2
 AND 17.
 SIKORSKY AIRCRAFT CORPORATION, STRATFORD, CT,
 UNITED TECHNOLOGIES CORPORATION, HARTFORD,
 CT:
 1,189,929. REN. 2-23-12. INT. CL. 12.
 SIKORSKY AIRCRAFT CORPORATION, STRATFORD, CT:
 4,118,249, PUB. 1-10-2012. INT. CL. 12.
 SILHOUETTE INTERNATIONAL SCHMIED AG, A-4020
 LINZ, AUSTRIA:
 2,967,661, CANC. INT. CL. 9.
 SILICON VALLEY INTERNATIONAL GROUP, INC., CAMP-
 BELL, CA:
 2,968,622, CANC. INT. CL. 16.
 SILVER MOUNTAIN PRODUCTIONS LLC, BETHPAGE,
 NY:
 4,117,762, PUB. 1-10-2012. INT. CL. 41.
 SILVER OAKS PUBLISHING, INC., MOLINE, IL:
 4,118,818, INT. CL. 9.
 SILVERBERG, JAMES LORIN, WASHINGTON, DC:
 2,968,819, CANC. MULTIPLE CLASS, INT. CLS. 16, 36, 41
 AND 42.
 SILVERQUINE LLC, SOUTHWEST RANCHES, FL:
 4,118,152, PUB. 1-10-2012. INT. CL. 5.

- SIMMS, GORDON M., YORK, PA:
2,968,445, CANC. INT. CL. 4.
- SIMON & SCHUSTER, INC., NEW YORK, NY:
4,119,217, INT. CL. 9.
- SIMON DOUGLAS THOMAS, HAWTHORN, VICTORIA,
AUSTRALIA:
4,117,422, PUB. 1-10-2012. INT. CL. 16.
- SIMPLEFARE LLC, BEAVERTON, OR:
4,119,510, INT. CL. 30.
- SIMPLY ORANGE JUICE COMPANY, APOPKA, FL:
4,118,893, INT. CL. 32.
- SINDERMANN, PHYLLIS, MAULIBU, CA:
2,967,916, CANC. INT. CL. 25.
- SINGER, JOAN D., ALEXANDRIA, VA:
2,467,378, CANC. INT. CL. 41.
- SINGERS COMPANY, LLC, PROVO, UT:
4,118,088, PUB. 1-10-2012. INT. CL. 41.
- SINU, INC., BRONX, NY:
2,966,174, CANC. INT. CL. 42.
- SIRIUS XM RADIO INC., NEW YORK, NY:
2,650,866, REN. 2-21-12. INT. CL. 41.
- SIS RESOURCES LTD., BET SHEMESH, ISRAEL:
4,117,977, PUB. 1-10-2012. INT. CL. 34.
- SISTEMA UNIVERSITARIO ANA G. MENDEZ, INC., SAN
JUAN, PUERTO RICO, AKA SUAGM:
4,117,531, PUB. 1-10-2012. INT. CL. 41.
- SISTERS' PANTRY, LLC, LYONS, CO:
4,117,482, PUB. 1-10-2012. INT. CL. 30.
4,117,483, PUB. 1-10-2012. INT. CL. 30.
- SITHOLE, DEBORAH I., ALBERTSON, NY:
2,968,097, CANC. INT. CL. 28.
- SITUATIONAL SERVICES, INCORPORATED, ANN AR-
BOR, MI:
2,567,550, REN. 2-22-12. INT. CL. 16.
- SIX BUTTONS, INC., HOLLYWOOD, CA:
4,117,970, PUB. 1-10-2012. INT. CL. 3.
- SIX WAVES INC., ROAD TOWN, TORTOLA, BR.VIRGIN
ISLANDS:
4,117,116, PUB. 1-10-2012. INT. CL. 41.
- SKILL CUBES, INC., KINGWOOD, TX:
2,907,106, CANC. INT. CL. 9.
- SKIN SO SWEET, INC., HUNTINGTON BEACH, CA:
4,118,377, PUB. 1-10-2012. INT. CL. 44.
4,118,378, PUB. 1-10-2012. INT. CL. 44.
- SKOVE, ELLYNNE, BROOKLYN, NY:
4,117,113, PUB. 1-10-2012. MULTIPLE CLASS, INT. CLS.
41 AND 44.
- SKRUF SNUS AB, STOCKHOLM, SWEDEN:
4,118,299, PUB. 1-10-2012. INT. CL. 34.
- SKYLINE CORPORATION, ELKHART, IN:
4,117,391, PUB. 1-10-2012. INT. CL. 12.
- SLEEMAN BREWERIES LTD./BRASSERIE SLEEMAN
LTEE, GUELPH, ONTARIO:
2,967,848, CANC. INT. CL. 32.
- SLENDER FIT U, LLC, MIAMI, FL:
4,117,588, PUB. 1-10-2012. INT. CL. 44.
4,117,589, PUB. 1-10-2012. INT. CL. 44.
- SLOW LORIS, INC., ANACORTES, WA:
4,118,318, PUB. 1-10-2012. INT. CL. 25.
- SLY BORD CO., N. MIAMI BEACH, FL:
4,118,650, PUB. 1-10-2012. INT. CL. 21.
- SMA SOLAR TECHNOLOGY AG, 34266 NIESTETAL, FED
REP GERMANY:
4,116,770, PUB. 1-10-2012. MULTIPLE CLASS, INT. CLS.
16 AND 41.
- SMALLCAKES, LLC, OVERLAND PARK, KS:
4,118,722, PUB. 1-10-2012. INT. CL. 35.
- SMART GRID SPEAK LLC, STANLEY, NC:
4,117,938, PUB. 1-10-2012. INT. CL. 35.
- SMART PRODUCT INNOVATIONS INC., JUNO BEACH, FL:
4,118,886, INT. CL. 7.
- SMARTPOOL, INC., LAKEWOOD, NJ:
4,116,581, PUB. 1-10-2012. INT. CL. 35.
4,116,582, PUB. 1-10-2012. INT. CL. 35.
- SMARTRAY INC., MARKHAM, CANADA:
4,119,076, INT. CL. 11.
- SMARTSILK CORPORATION INC., MONTREAL QC, CA-
NADA:
4,117,295, PUB. 1-10-2012. MULTIPLE CLASS, INT. CLS.
20 AND 24.
- SMASH MARKETING LLC, CENTENNIAL, CO:
4,117,322, PUB. 1-10-2012. INT. CL. 35.
- SMC CORPORATION, TOKYO, JAPAN:
4,116,888, PUB. 1-10-2012. INT. CL. 11.
- SMILING LEAF, L.L.C., BALTIMORE, MD, AKA SEVI
ORGANICS:
2,855,354, CANC. INT. CL. 3.
- SMITH & VANDIVER, CORP., WATSONVILLE, CA:
4,116,600, PUB. 1-10-2012. INT. CL. 3.
- SMITH INTERNATIONAL, INC., HOUSTON, TX:
4,119,237, MULTIPLE CLASS, INT. CLS. 7 AND 37.
- SMITH, GINEVRA CASA, WALLA WALLA, WA AND
SMITH, CHARLES, WALLA WALLA, WA:
4,119,449, INT. CL. 33.
- SMITH, KIMBERLEY G., HURST, TX:
2,468,312, CANC. INT. CL. 28.
- SMITH, TYRONE JR, HEPHZIBAH, GA:
4,119,599, INT. CL. 25.
- SMOAK, ANDREA V., ARLINGTON, VA:
4,117,082, PUB. 1-10-2012. MULTIPLE CLASS, INT. CLS.
35 AND 45.
- SMOKIN JOKERS, GRAYSLAKE, IL:
4,118,024, PUB. 1-10-2012. INT. CL. 35.
- SMOKIN' RACK PRODUCTS, LLC, HARDINGSBURG, KY:
4,117,408, PUB. 1-10-2012. MULTIPLE CLASS, INT. CLS. 5
AND 28.
4,117,409, PUB. 1-10-2012. INT. CL. 9.
- SMS GMBH, 40237 DÜSSELDORF, FED REP GERMANY:
4,116,678, PUB. 1-10-2012. MULTIPLE CLASS, INT. CLS.
1, 2, 6, 7, 9, 11, 16, 19, 35, 37, 40, 41 AND 42.
- SNAP-TITE TECHNOLOGIES, INC., WILMINGTON, DE:
4,116,558, PUB. 1-10-2012. INT. CL. 37.
- SNASHALL, THOMAS, BINGHAMTON, NY:
4,119,178, INT. CL. 25.
- SNEAKER HEADZ, LLC, ROYAL OAK, MI, DBA BURN
RUBBER:
4,117,033, PUB. 1-10-2012. INT. CL. 25.
- SNECMA, PARIS, FRANCE:
3,039,814, CANC. MULTIPLE CLASS, INT. CLS. 9, 12
AND 40.
- SNOW PEAK INC., NIIGATA, JAPAN:
4,117,834, PUB. 1-10-2012. MULTIPLE CLASS, INT. CLS. 9
AND 18.
- SNYDER INTERNET MARKETING, INC., PITTSBURGH,
PA:
2,967,407, CANC. INT. CL. 42.
- SO NEW YORK INC., FLUSHING, NY:
4,117,753, PUB. 1-10-2012. INT. CL. 30.
- SOCIAL MEDIA EVENTS, S.L., MADRID, SPAIN:
4,116,690, PUB. 1-10-2012. MULTIPLE CLASS, INT. CLS.
35 AND 41.
- SOCIALEYEZ FZE, DUBAI, UNITED ARAB EMIR.:
4,117,512, PUB. 1-10-2012. MULTIPLE CLASS, INT. CLS.
35 AND 42.
- SOCIALIZE, INC., SAN FRANCISCO, CA:
4,117,712, PUB. 1-10-2012. INT. CL. 38.
- SOCIALLY OVERWHELMED, LLC, PHOENIX, AZ:
4,117,101, PUB. 1-10-2012. INT. CL. 35.
- SOCIETE DES PRODUITS NESTLE S.A., 1800 VEVEY,
SWITZERLAND, WILLIAMSON CANDY CO., CHICAGO,
IL:
152,550, REN. 2-22-12. U.S. CL. 46 (INT. CL. 30).
- SOCIETE DES PRODUITS NESTLE S.A., 1800 VEVEY,
SWITZERLAND:
394,221, REN. 2-22-12. U.S. CL. 46 (INT. CL. 29).
4,116,633, PUB. 1-10-2012. INT. CL. 11.
4,118,976, MULTIPLE CLASS, INT. CLS. 30 AND 32.
- SOCIETE DES PRODUITS NESTLE, S.A., 1800 VEVEY,
SWITZERLAND:
2,968,474, CANC. INT. CL. 10.
- SOCIETY FOR VASCULAR SURGERY, CHICAGO, IL:
4,117,316, PUB. 1-10-2012. MULTIPLE CLASS, INT. CLS.
42 AND 44.

SOCOREX ISBA S.A., 1024 ECUBLENS/VD, SWITZERLAND:
1,676,311. REN. 2-22-12. INT. CL. 9.

SOFTELEC GMBH, MUENCHEN, FED REP GERMANY:
2,546,814. REN. 2-17-12. INT. CL. 9.

SOFTLINK INTERNATIONAL LIMITED, QUEENSLAND,
AUSTRALIA:
2,967,566. CANC. INT. CL. 9.

SOFTPRO GMBH, BOEBLINGEN, FED REP GERMANY:
3,038,762. CANC. INT. CL. 42.
4,118,789. INT. CL. 9.

SOHOBOGO ENTERPRISE, LLC, TAMPA, FL, AKA SOHO-
BOGO OR SOHOBOGO.COM AND ASTA, MATTHEW A.,
TAMPA, FL:
4,117,784. PUB. 1-10-2012. INT. CL. 35.

SOILAND CO., INC., SANTA ROSA, CA:
4,117,561. PUB. 1-10-2012. INT. CL. 31.
4,117,569. PUB. 1-10-2012. INT. CL. 1.

SOILMOISTURE EQUIPMENT CORP., GOLETA, CA:
4,119,269. INT. CL. 9.

SOL-MILLENNIUM MEDICAL, INC., LAWRENCEVILLE,
GA:
2,967,597. CANC. INT. CL. 10.

SOLARCART SOLUTIONS, BONITA SPRINGS, FL:
4,118,415. PUB. 1-10-2012. INT. CL. 12.

SOLAUS HOUSE, LLC, ACWORTH, GA:
2,968,400. CANC. INT. CL. 16.

SOLCE, NATASHA, HOUSTON, TX:
4,117,365. PUB. 1-10-2012. INT. CL. 41.

SOLIDTHINKING, INC., TROY, MI:
4,118,918. INT. CL. 9.

SOLIUM CAPITAL INC., CALGARY, ALBERTA, CANADA:
4,116,963. PUB. 1-10-2012. MULTIPLE CLASS, INT. CLS. 9
AND 42.

SOMERS-HILL, SHARON MAY, NEWPORT BEACH, CA:
4,118,776. MULTIPLE CLASS, INT. CLS. 24 AND 25.

SOMETHING GOOD, INC., SOUTH JORDAN, UT:
2,967,568. CANC. INT. CL. 41.

SOMOS OHANA NICARAGUA, PUKALANI, HI:
4,117,105. PUB. 1-10-2012. MULTIPLE CLASS, INT. CLS.
35 AND 36.

SONIC SOLUTIONS, NOVATO, CA:
2,926,911. CANC. INT. CL. 9.

SONY KABUSHIKI KAISHA, TOKYO, JAPAN, TA SONY
CORPORATION:
2,967,607. CANC. INT. CL. 9.

SONY PICTURES HOME ENTERTAINMENT INC., CUL-
VER CITY, CA:
4,119,359. INT. CL. 9.
4,119,360. INT. CL. 9.

SOPHERION THERAPEUTICS, PRINCETON, NJ:
2,967,533. CANC. INT. CL. 42.

SOUND DEVICES, LLC, REEDSBURG, WI:
2,550,019. REN. 2-21-12. INT. CL. 9.

SOUND SLEEP SYSTEMS, INC., ASHTABULA, OH:
2,466,965. CANC. INT. CL. 35.

SOUTH BEACH CANDLE COMPANY, HIALEAH, FL:
4,118,460. PUB. 1-10-2012. INT. CL. 4.

SOUTH DAKOTA STATE UNIVERSITY, BROOKINGS, SD:
3,174,209. CANC. INT. CL. 25.

SOUTHAMERICA.TRAVEL LLC, CHEHALIS, WA:
4,117,133. PUB. 1-10-2012. INT. CL. 39.

SOUTHERN CALIFORNIA MINORITY BUSINESS DEVEL-
OPMENT COUNCIL, INC., LOS ANGELES, CA:
2,894,773. CANC. INT. CL. 41.

SOUTHERN COMPANY, THE, ATLANTA, GA:
2,967,390. CANC. INT. CL. 39.

SOUTHERN PRIDE DISTRIBUTING, LLC, MARION, IL:
4,119,455. INT. CL. 11.

SOVERNET, INC., BELLOWS FALLS, VT:
2,665,753. REN. 2-23-12. MULTIPLE CLASS, INT. CLS. 38
AND 42.

SOWIND S.A. (SOWIND A.G.) (SOWIND LTD), SWITZER-
LAND:
4,116,754. PUB. 1-10-2012. INT. CL. 14.

SPADACCINI, JIM, CORRALES, NM:
2,467,362. CANC. INT. CL. 42.

SPANISH VINES, INC., COLUMBIA, SC:
4,119,411. INT. CL. 33.
4,119,412. INT. CL. 33.

SPARK, HOUSTON, TX:
2,673,807. REN. 2-22-12. INT. CL. 41.

SPARK ASSOCIATES INC., LANCATSER, PA:
4,116,648. PUB. 6-1-2010. INT. CL. 43.
4,116,649. PUB. 6-1-2010. INT. CL. 43.

SPC RESOURCES, INC., HARTSVILLE, SC, SONOCO PRO-
DUCTS COMPANY, HARTSVILLE, SC:
552,840. REN. 2-17-12. U.S. CL. 2 (INT. CL. 16).

SPC RESOURCES, INC., HARTSVILLE, SC, CRELLIN PLAS-
TICS CORPORATION, CHATHAM, NY:
948,771. REN. 2-20-12. U.S. CL. 2 (INT. CL. 20).

SPECIAL OPS NUTRITION, L.L.C., DRIGGS, ID:
2,968,184. CANC. INT. CL. 32.

SPECIALTY FAMILY FOUNDATION, SANTA MONICA,
CA:
4,117,453. PUB. 1-10-2012. MULTIPLE CLASS, INT. CLS.
35 AND 36.

SPECIALTY FASHION GROUP LTD, ALEXANDRIA, NSW,
AUSTRALIA:
4,116,944. PUB. 1-10-2012. MULTIPLE CLASS, INT. CLS.
14, 25 AND 35.

SPECIALTY PRODUCTS OF GREENWOOD, MISSOURI,
INC., GREENWOOD, MO:
2,651,744. REN. 2-21-12. INT. CL. 16.

SPECTRUM TRACKING SYSTEMS, INC., CARROLLTON,
TX:
4,117,768. PUB. 1-10-2012. INT. CL. 45.
4,118,681. PUB. 1-10-2012. INT. CL. 45.

SPEEDWAY SUPERAMERICA LLC, ENON, OH:
2,968,052. CANC. INT. CL. 35.

SPIELO MANUFACTURING ULC, MONCTON, NEW
BRUNSWICK, CANADA:
2,968,255. CANC. INT. CL. 9.

SPIER WINES (PROPRIETARY) LIMITED, STELLENBOSCH
7600, SOUTH AFRICA:
3,957,116. COR. INT. CL. 33.

SPIRIT OF HEALING, INC., KERNERSVILLE, NC:
2,467,914. CANC. INT. CL. 5.

SPIRITS INTERNATIONAL B.V., LUXEMBOURG:
4,116,695. PUB. 1-10-2012. INT. CL. 33.

SPIRITWORLD PRODUCTIONS, INC., HUNTINGTON
BEACH, CA TO SPIRIT WORLD NEVADA, INC., HEN-
DERSON, NV:
2,466,956. CANC. INT. CL. 41.

SPIRO ENTERPRISES B.V., 5845 EL SINT ANTHONIS,
NETHERLANDS:
1,676,675. REN. 2-21-12. INT. CL. 11.

SPLendid PRODUCTS LLC, BURLINGAME, CA, SPLEN-
DID PRODUCTS LLC, BURLINGAME, CA:
2,530,291. REN. 2-22-12. INT. CL. 31.

SPOERRY 1866 AG, FLUMS, SWITZERLAND:
2,541,088. REN. 2-21-12. INT. CL. 24.
2,541,088. CANC. MULTIPLE CLASS, INT. CLS. 9 AND
27.

SPORT HELMETS INC., LIVERPOOL, NY:
4,116,622. PUB. 1-10-2012. INT. CL. 9.
4,116,623. PUB. 1-10-2012. INT. CL. 9.
4,116,624. PUB. 1-10-2012. INT. CL. 9.
4,116,625. PUB. 1-10-2012. INT. CL. 9.
4,116,626. PUB. 1-10-2012. INT. CL. 9.

SPORTECH VENUES INC., NEW HAVEN, CT:
2,467,623. CANC. INT. CL. 41.
2,467,624. CANC. INT. CL. 41.

SPORTS IMPROVEMENT PRODUCTS, INC., FOREST
PARK, GA:
2,968,643. CANC. INT. CL. 28.

SPORTS MANAGEMENT NEWS, INC., GLEN MILLS, PA:
2,467,843. CANC. INT. CL. 16.

SPORTS OUTDOOR AND RECREATION (SOAR) PARK,
SAN ANTONIO, TX:
4,119,233. INT. CL. 41.
4,119,234. INT. CL. 41.
4,119,235. INT. CL. 41.

- SPORTS PICK INTERNATIONAL HOLDINGS, INC., BRIDGETOWN, BARBADOS:
2,955,824, CANC. MULTIPLE CLASS, INT. CLS. 35 AND 41.
- SPRIANO FLUID MECHANICS S.R.L., 20010 CORNAREDO (MI), ITALY:
4,117,010, PUB. 1-10-2012. MULTIPLE CLASS, INT. CLS. 6 AND 9.
- SPRING WIRELESS USA, INC., SEATTLE, WA:
4,119,400, INT. CL. 42.
- SPRINGBOARD NON-PROFIT CONSUMER CREDIT MANAGEMENT, INC., RIVERSIDE, CA, SPRINGBOARD NON-PROFIT CONSUMER CREDIT MANAGEMENT, INC., RIVERSIDE, CA:
2,577,739, REN. 2-21-12. MULTIPLE CLASS, INT. CLS. 36 AND 41.
- SPRINGBOK GROUP, SALT LAKE CITY, UT:
4,118,734, PUB. 1-10-2012. INT. CL. 25.
- SPRINGCM INC., CHICAGO, IL:
4,118,020, PUB. 1-10-2012. INT. CL. 42.
4,118,406, PUB. 1-10-2012. INT. CL. 42.
- SPRINGFOOT, INC., KNOXVILLE, TN:
1,183,868, REN. 2-22-12. INT. CL. 25.
- SPRINT COMMUNICATIONS COMPANY L.P., OVERLAND PARK, KS:
4,116,550, PUB. 8-9-2011. INT. CL. 38.
- SPS TECHNOLOGIES, LLC, JENKINTOWN, PA:
2,462,098, REN. 2-17-12. INT. CL. 6.
- STRY IMPORTS LLC, PORT WASHINGTON, NY:
4,119,357, INT. CL. 18.
4,119,358, INT. CL. 18.
- ST. CROIX OF PARK FALLS, LTD., PARK FALLS, WI:
2,582,735, REN. 2-22-12. INT. CL. 28.
- STACY'S PITA CHIP COMPANY, INC., RANDOLPH, MA:
4,116,638, PUB. 1-10-2012. INT. CL. 30.
- STAEDTLER, INC., CHATSWORTH, CA TO STAEDTLER, INC., CHATSWORTH, CA:
2,467,284, CANC. INT. CL. 16.
- STAMBUL, DEREK C, FORT LAUDERDALE, FL:
4,117,779, PUB. 1-10-2012. INT. CL. 45.
- STAND UP OUTFITTERS LLC, NEW BERN, NC:
4,118,188, PUB. 1-10-2012. INT. CL. 35.
- STANG, JOSEPH A, BELLAIRE, TX, DBA MATCH AND MINGLE:
4,116,994, PUB. 1-10-2012. MULTIPLE CLASS, INT. CLS. 41 AND 45.
- STANLEY CREATIONS, INC., MELROSE PARK, PA:
4,119,636, INT. CL. 14.
- STANLEY LOGISTICS, L.L.C., BEW BRITAIN, CT, PLOMB TOOL COMPANY, THE, LOS ANGELES, CA:
555,093, REN. 2-21-12. U.S. CL. 26 (INT. CL. 9).
- STANLEY, JOHN D., BEDIAS, TX:
4,119,117, INT. CL. 16.
- STANTON CARPET CORPORATION, SYOSSET, NY:
4,118,836, INT. CL. 27.
- STARBRANDS NETWORKS, LLC, HENDERSON, NV:
4,075,939, AM. INT. CL. 35.
- STARBUCKS CORPORATION, SEATTLE, WA, DBA STARBUCKS COFFEE COMPANY:
4,118,692, PUB. 1-10-2012. INT. CL. 41.
- STARKIST CO., PITTSBURGH, PA:
4,117,434, PUB. 1-10-2012. INT. CL. 29.
- STARLIGHT CHILDREN'S FOUNDATION, LOS ANGELES, CA:
2,554,684, REN. 2-21-12. INT. CL. 38.
- STARMARK, INC., SAN DIEGO, CA, STARMARK, INC., SAN DIEGO, CA:
1,676,599, REN. 2-17-12. INT. CL. 9.
- STARSKYMATIC, INC., WILMINGTON, DE:
4,117,859, PUB. 1-10-2012. MULTIPLE CLASS, INT. CLS. 35 AND 38.
- STARWOOD HOTELS & RESORTS WORLDWIDE, INC., WHITE PLAINS, NY:
2,525,771, REN. 2-22-12. INT. CL. 35.
4,119,238, INT. CL. 43.
- STARZ ENTERTAINMENT, LLC, ENGLEWOOD, CO:
4,119,057, MULTIPLE CLASS, INT. CLS. 38 AND 41.
- STAT HEALTH SERVICES, INC., SANTA ANA, CA:
4,119,044, MULTIPLE CLASS, INT. CLS. 35 AND 44.
- STATE ATOMIC ENERGY CORPORATION "ROSATOM", 119017 MOSCOW, RUSSIAN FED.:
4,116,894, PUB. 1-10-2012. INT. CL. 17.
- STATE INDUSTRIAL PRODUCTS CORPORATION, CLEVELAND, OH, NEUTRON INDUSTRIES, INC., PHOENIX, AZ:
1,681,729, REN. 2-19-12. INT. CL. 3.
- STEAKBURGER, INC., HARVEY, LA:
1,676,237, REN. 2-19-12. INT. CL. 42.
- STEEL AND PIPE SUPPLY COMPANY, INC., MANHATTAN, KS:
4,117,315, PUB. 1-10-2012. INT. CL. 42.
- STEEL GRIP, INC., DANVILLE, IL:
1,666,594, REN. 2-22-12. INT. CL. 9.
- STEEL-JONES, JOAN, CLEARWATER, FL:
4,117,841, PUB. 1-10-2012. INT. CL. 40.
- STEIER, RODNEY, EAST HARTFORD, CT:
4,117,066, PUB. 1-10-2012. INT. CL. 6.
- STELFAST INC., MISSISSAUGA, ONTARIO, CANADA:
2,465,988, REN. 2-22-12. MULTIPLE CLASS, INT. CLS. 6 AND 12.
- STEPHEN REICH, PH.D., PSYCHOLOGIST, P.C., NEW YORK, NY:
4,119,770, MULTIPLE CLASS, INT. CLS. 44 AND 45.
- STERIL-AIRE, INC., BURBANK, CA:
2,538,825, REN. 2-17-12. INT. CL. 11.
- STERIS CORPORATION, MENTOR, OH:
1,681,581, REN. 2-17-12. INT. CL. 3.
- STERLING PUBLISHING CO., INC., NEW YORK, NY:
4,119,018, INT. CL. 16.
4,119,019, INT. CL. 16.
- STEWART, JAMES, NEW YORK, NY:
2,967,863, CANC. INT. CL. 35.
- STI LABS INC., TARZANA, CA:
2,968,447, CANC. INT. CL. 5.
- STICHTING CENTER FOR TRANSLATIONAL MOLECULAR MEDICINE, NETHERLANDS:
4,116,712, PUB. 1-10-2012. MULTIPLE CLASS, INT. CLS. 10, 35, 36, 41 AND 42.
- STICHTING CENTER FOR TRANSLATIONAL MOLECULAR MEDICINE, NL-5656 AG EINDHOVEN, NETHERLANDS:
4,116,718, PUB. 1-10-2012. MULTIPLE CLASS, INT. CLS. 10, 35, 36, 41 AND 42.
- STICHTING ENERGIEONDERZOEK CENTRUM NEDERLAND, PETTEN, NETHERLANDS:
4,118,895, INT. CL. 11.
- STIEFEL LABORATORIES, INC., WILMINGTON, DE:
2,468,155, CANC. INT. CL. 5.
- STIMULUS BRANDS LLC, BURNSVILLE, MN:
4,118,312, PUB. 1-10-2012. INT. CL. 11.
- STOKELY-VAN CAMP, INC., CHICAGO, IL:
2,968,493, CANC. INT. CL. 32.
- STOKES CANNING COMPANY, AURORA, CO:
4,118,495, PUB. 1-10-2012. INT. CL. 30.
- STONCOR GROUP, INC., MAPLE SHADE, NJ:
4,118,778, INT. CL. 19.
- STONE HART BRAND LLC, MIAMI, FL:
4,117,558, PUB. 10-4-2011. INT. CL. 41.
- STONE SOUP CREATIONS, LLC, SHERWOOD, WI:
2,934,404, CANC. INT. CL. 25.
- STONE, ROLAND B., NASHVILLE, TN:
2,524,925, REN. 2-22-12. INT. CL. 9.
- STONEWOOD RESTAURANT GROUP, LLC, ORMOND BEACH, FL:
2,968,597, CANC. INT. CL. 16.
- STONKUS, MARK A., COHASSET, MA:
4,118,165, PUB. 1-10-2012. MULTIPLE CLASS, INT. CLS. 41 AND 44.
- STONYFIELD FARM, INC., LONDONDERRY, NH:
4,119,447, MULTIPLE CLASS, INT. CLS. 5 AND 29.
- STOOPID TOURING, ENCINO, CA:
4,118,278, PUB. 1-10-2012. INT. CL. 41.
- STORAGEFLEX INC., MARKHAM ONTARIO, CANADA:
2,967,713, CANC. MULTIPLE CLASS, INT. CLS. 9 AND 42.

STRAPWORKS LLC, EUGENE, OR, DBA MOOSE PET WEAR:
4,118,144, PUB. 1-10-2012. INT. CL. 18.

STRATAGEN, INC., HOUSTON, TX:
4,119,759, INT. CL. 35.

STRATEGIC SOLUTIONS INTERNATIONAL, INC., WILMINGTON, DE:
4,117,802, PUB. 1-10-2012. MULTIPLE CLASS, INT. CLS. 41 AND 45.
4,118,544, PUB. 1-10-2012. MULTIPLE CLASS, INT. CLS. 35 AND 45.
4,118,545, PUB. 1-10-2012. MULTIPLE CLASS, INT. CLS. 35 AND 42.

STRAUSS WATER LTD., PETACH TIKVA, ISRAEL:
4,116,983, PUB. 1-10-2012. MULTIPLE CLASS, INT. CLS. 1, 11 AND 32.

STRICKLER, WAYNE T., TUCSON, AZ:
2,968,118, CANC. INT. CL. 28.

STRICTLY NATURAL PRODUCTS, INC., RIVERSIDE, CA:
4,118,275, PUB. 1-10-2012. INT. CL. 5.

STRIP STRIP HOORAY!, INC., ENCINO, CA:
4,118,122, PUB. 1-10-2012. INT. CL. 41.

STRIVE COACHING INC, TOPEKA, KS, DBA PROFIT THINK TANK:
4,119,814, INT. CL. 35.

STROMBERG, RUSSELL M., KIRKLAND, WA:
2,968,621, CANC. INT. CL. 42.

STRONG COMPANY INC., THE, PINE BLUFF, AR, STRONG-LITE PRODUCTS CORPORATION, PINE BLUFF, AR:
1,713,661. REN. 2-23-12. INT. CL. 17.

STRYKER CORPORATION, KALAMAZOO, MI:
4,119,387, INT. CL. 10.

STUART, BRUCE S, SAN FRANCISCO, CA:
4,119,465, INT. CL. 41.

STUDENT LOAN FINANCE CORPORATION, ABERDEEN, SD:
2,967,540, CANC. INT. CL. 36.

STUDIO IP HOLDINGS LLC, WILMINGTON, DE:
4,119,716, INT. CL. 25.

STUDIO MODERNA SA, CH-6900 LUGANO, SWITZERLAND:
4,116,802, PUB. 1-10-2012. INT. CL. 1.

STUDIO ONE NETWORKS, INC., NEW YORK, NY:
4,118,200, PUB. 1-10-2012. INT. CL. 41.
4,118,334, PUB. 1-10-2012. INT. CL. 41.

STUTZMAN, CHARLES D., ALBUQUERQUE, NM:
2,543,231. REN. 2-23-12. INT. CL. 42.

STYLI-STYLE, INC., VENICE, CA:
2,972,546, CANC. INT. CL. 3.

SU, HUI FANG HUANG "ANGIE", BOCA RATON, FL:
2,467,580, CANC. MULTIPLE CLASS, INT. CLS. 16 AND 41.

SUAREZ-MENENDEZ, JORGE, CORAL GABLES, FL:
4,117,426, PUB. 1-10-2012. INT. CL. 3.

SUBIACO ABBEY, SUBIACO, AR:
4,118,137, PUB. 1-10-2012. INT. CL. 30.
4,118,139, PUB. 1-10-2012. INT. CL. 30.

SUCCESS IN ACTION LLC, RINGGOLD, GA:
4,119,521, INT. CL. 5.

SUMITOMO BAKELITE CO., LTD., JAPAN:
4,116,855, PUB. 1-10-2012. INT. CL. 17.

SUMITOMO RUBBER INDUSTRIES, LTD., HYOGO, JAPAN AND JAPAN RESEARCH INSTITUTE, LTD., THE, TOKYO 102-0075, JAPAN:
2,967,422, CANC. INT. CL. 9.

SUMMIT ENERGY SERVICES, INC., LOUISVILLE, KY:
2,467,742, CANC. INT. CL. 36.

SUMMIT ENTERTAINMENT, LLC, SANTA MONICA, CA:
4,119,734, INT. CL. 16.

SUMMIT GLOVE INC., MINERVA, OH:
4,118,723, PUB. 1-10-2012. INT. CL. 21.

SUN CHEMICAL CORPORATION, PARSIPPANY, NJ, UNITED STATES PRINTING INK, CORP., EAST RUTHERFORD, NJ:
1,675,639. REN. 2-17-12. INT. CL. 2.

SUN CHEMICAL CORPORATION, PARSIPPANY, NJ:
2,467,952, CANC. INT. CL. 2.

SUN LIQUOR MFG, INC., SEATTLE, WA:
4,119,710, INT. CL. 33.

SUN NUCLEAR CORP., MELBOURNE, FL:
4,119,353, INT. CL. 10.

SUN-TEK MANUFACTURING, INC., ORLANDO, FL:
2,968,087, CANC. INT. CL. 6.

SUNBEAM PRODUCTS, INC., BOCA RATON, FL, CHICAGO FLEXIBLE SHAFT COMPANY, CHICAGO, IL:
390,181. REN. 2-22-12. U.S. CL. 21 (INT. CLS. 7, 9, 11, 12 AND 15).

SUNTORY LIMITED, KITA-KU, OSAKA, JAPAN:
2,528,258. REN. 2-22-12. INT. CL. 31.

SUPER DUPER INC., GREENVILLE, SC, DBA SUPER DUPER PUBLICATIONS:
2,664,468. REN. 2-23-12. INT. CL. 41.

SUPER SPROUTZ, LLC, NEW YORK, NY:
4,118,864, MULTIPLE CLASS, INT. CLS. 16 AND 41.

SUPER VISTA CORP., NEW YORK, NY:
2,491,924. REN. 2-22-12. INT. CL. 9.

SUPERB MECHANICAL SERVICES, INC., NAPLES, FL:
4,118,459, PUB. 1-10-2012. INT. CL. 37.

SUPERBA, INC., LOS ANGELES, CA:
2,968,559, CANC. INT. CL. 25.
2,968,580, CANC. INT. CL. 25.

SUPERIOR HIKING TRAIL ASSOCIATION, TWO HARBORS, MN:
4,118,062, PUB. 1-10-2012. INT. CL. 41.

SUPERVALU INC., EDEN PRAIRIE, MN:
4,119,709, INT. CL. 35.

SURFRIDER FOUNDATION, SAN CLEMENTE, CA:
4,117,801, PUB. 1-10-2012. INT. CL. 35.

SURROGACY EXPERIENCE, LLC, NEPTUNE, NJ:
4,119,304, INT. CL. 44.

SURVIVOR PRODUCTIONS LLC, LOS ANGELES, CA:
4,117,583, PUB. 1-10-2012. INT. CL. 41.

SUSTAINONE, LLC, WOODLAND, WA:
4,118,908, INT. CL. 35.
4,118,909, INT. CL. 35.

SUTTON DAVID, CHELTENHAM, UNITED KINGDOM:
4,119,573, INT. CL. 25.

SUTTON, GEORGE R., HOLIDAY, FL:
4,118,404, PUB. 1-10-2012. INT. CL. 41.

SUUNTO OY, VANTAA, FINLAND:
4,118,972, MULTIPLE CLASS, INT. CLS. 9 AND 14.
4,118,973, MULTIPLE CLASS, INT. CLS. 9 AND 14.
4,118,981, MULTIPLE CLASS, INT. CLS. 9 AND 14.

SWATCH S.A., BIENNE, SWITZERLAND:
1,671,076. REN. 2-23-12. INT. CL. 14.

SWEDISH MATCH NORTH EUROPE AB, STOCKHOLM, SWEDEN:
4,116,617, PUB. 1-10-2012. INT. CL. 34.
4,116,618, PUB. 1-10-2012. INT. CL. 34.
4,116,619, PUB. 1-10-2012. INT. CL. 34.

SWEET DANI B, LLC, WEEHAWKEN, NJ:
4,117,182, PUB. 1-10-2012. INT. CL. 21.

SWEETGRASS, LLC, SEATTLE, WA:
2,968,356, CANC. MULTIPLE CLASS, INT. CLS. 35 AND 42.

SWEETLAND, DAVID E., COOKEVILLE, TN:
4,118,000, PUB. 1-10-2012. INT. CL. 41.

SWICKPIX, LLC, NEW CANAAN, CT:
4,118,491, PUB. 1-10-2012. INT. CL. 41.

SWIFT FINANCIAL SERVICES LTD., LANGLEY, BRITISH COLUMBIA, CANADA:
2,967,642, CANC. INT. CL. 5.

SWIMC, INC., NEWARK, DE:
2,967,926, CANC. INT. CL. 2.
2,968,095, CANC. INT. CL. 5.

SWISS WATCH INTERNATIONAL, HOLLYWOOD, FL:
2,968,419, CANC. MULTIPLE CLASS, INT. CLS. 9, 16 AND 18.

SWISSIMPLANT AG, SWITZERLAND:
2,967,217.

SYMANTEC CORPORATION, MOUNTAIN VIEW, CA:
2,968,343, CANC. INT. CL. 9.

SYMMETRICS MARKETING CORPORATION, TEMPE, AZ:
2,967,434, CANC. INT. CL. 35.

- SYMRISE AG, HOLZMINDEN, FED REP GERMANY:
4,118,951, INT. CL. 42.
- SYMVIONICS, INC., ARCADIA, CA:
2,968,653, CANC. INT. CL. 42.
- SYNBIOTICS CORPORATION, SAN DIEGO, CA:
929,019, REN. 2-17-12. U.S. CL. 18 (INT. CL. 5).
2,525,716, REN. 2-22-12. INT. CL. 5.
- SYNERGY BANK, HOUMA, LA:
2,537,725, REN. 2-22-12. INT. CL. 36.
- SYNERGY SERVICES, INC., FOLEY, AL:
2,968,027, CANC. INT. CL. 1.
- SYNERGYLIST, INC., PALO ALTO, CA:
4,119,743, MULTIPLE CLASS, INT. CLS. 35 AND 41.
- SYNEXUS GLOBAL INC., OAKVILLE, ONTARIO, CANADA:
2,967,563, CANC. INT. CL. 9.
- SYNOPSIS, INC., MOUNTAIN VIEW, CA:
2,967,731, CANC. INT. CL. 9.
- T & BEER, INC. OLD TAPPAN, NJ, DBA SIMONE INTERNATIONAL:
4,119,662, INT. CL. 33.
- T & R ELECTRIC SUPPLY COMPANY, INC., COLMAN, SD:
933,490, REN. 2-22-12. U.S. CL. 21 (INT. CL. 9).
- T H R & ASSOCIATES, INC., SPRINGFIELD, IL:
4,051,843, CANC. INT. CL. 41.
4,051,844, CANC. INT. CL. 35.
- T. MARZETTI COMPANY, COLUMBUS, OH:
4,117,376, PUB. 1-10-2012. INT. CL. 30.
4,117,401, PUB. 1-10-2012. INT. CL. 29.
- T.F.H. PUBLICATIONS, INC., NEPTUNE CITY, NJ, T.F.H. PUBLICATIONS, INC., NEPTUNE, NJ, DBA NYLABONE:
1,731,435, REN. 2-17-12. INT. CL. 31.
- T-GATE, LLC, SCHAUMBURG, IL:
4,119,020, INT. CL. 36.
- T-HOUSE, INC., PHILADELPHIA, PA:
4,119,045, INT. CL. 40.
- T-MOBILE USA, INC., BELLEVUE, WA:
4,119,613, INT. CL. 9.
- TA ASSOCIATES MANAGEMENT L.P., BOSTON, MA:
4,117,808, PUB. 1-10-2012. INT. CL. 36.
- TABACOS CARBONELL, S.A., PALMAREJO, VILLA GONZA, DOMINICAN REP:
4,117,342, PUB. 1-10-2012. INT. CL. 34.
- TABLETOPS UNLIMITED, INC., GARDENA, CA:
2,968,160, CANC. INT. CL. 21.
- TADEVOSYAN, ALEN, BURBANK, CA, DBA PRISON CHANNEL:
4,119,761, INT. CL. 41.
- TAG METALS CORP., LOS ANGELES, CA:
2,519,016, REN. 2-21-12. INT. CL. 12.
- TAI, CHIH-CHENG, SUNNYVALE, CA, AKA DR. JOE TAI:
4,117,756, PUB. 1-10-2012. INT. CL. 21.
- TAISUKE CO., LTD., SHIBUYA-KU, TOKYO, JAPAN:
2,467,007, CANC. INT. CL. 25.
- TAKE TWO INTERACTIVE SOFTWARE, INC., NEW YORK, NY:
2,967,478, CANC. INT. CL. 28.
- TAKE-TWO INTERACTIVE SOFTWARE, INC., NEW YORK, NY:
4,118,923, MULTIPLE CLASS, INT. CLS. 9 AND 41.
- TAKEDA PHARMACEUTICAL COMPANY LIMITED, CHUO-KU, OSAKA, JAPAN:
4,117,168, PUB. 1-10-2012. INT. CL. 5.
4,117,169, PUB. 1-10-2012. INT. CL. 5.
- TALBOTS GROUP, LIMITED PARTNERSHIP, THE, HINGHAM, MA:
4,118,271, PUB. 1-10-2012. MULTIPLE CLASS, INT. CLS. 14, 18, 25 AND 35.
- TALMI, BEN, BOSTON, MA:
4,119,312, INT. CL. 41.
- TAPJOY, INC., SAN FRANCISCO, CA:
4,118,236, PUB. 1-10-2012. MULTIPLE CLASS, INT. CLS. 9, 35 AND 42.
- TARGET BRANDS, INC., MINNEAPOLIS, MN:
4,119,195, INT. CL. 25.
- TARGET RESEARCH GROUP, INC., NANUET, NY:
4,118,248, PUB. 1-10-2012. MULTIPLE CLASS, INT. CLS. 35 AND 42.
- TASTE OF THE VINE LTD, HASLEMERE, SURREY, UNITED KINGDOM:
2,968,491, CANC. INT. CL. 41.
- TATE, TRACY ELIZABETH, VICTORVILLE, CA, DBA CAGE CANDY:
4,118,162, PUB. 1-10-2012. INT. CL. 25.
- TAVERAS, ANTONIO C., PROVIDENCE, RI, DBA TONY'S ENTERPRISE:
4,119,257, INT. CL. 5.
- TAXCENTS, LLC, PHOENIX, AZ:
2,967,466, CANC. INT. CL. 16.
- TAYLOR, DAN, SEATTLE, WA:
2,467,545, CANC. INT. CL. 42.
- TCF CO. LLC, CALABASAS, CA, CHEESECAKE FACTORY ASSETS CO. LLC, THE, CALABASAS HILLS, CA:
2,650,244, REN. 2-22-12. INT. CL. 30.
- TCF FINANCIAL CORPORATION, WAYZATA, MN:
2,519,134, REN. 2-17-12. INT. CL. 36.
- TCG, INC., MINNEAPOLIS, MN:
4,116,560, PUB. 1-11-2011. INT. CL. 35.
- TCL INTERNATIONAL BUSINESS LLC, EDISON, NJ:
4,119,696, INT. CL. 25.
- TCT MOBILE LIMITED, IRVINE, CA:
4,119,080, INT. CL. 9.
- TEAC CORPORATION, TOKYO, JAPAN:
2,468,105, CANC. INT. CL. 9.
- TEAM CONSUMER PRODUCTS, LLC, FALLS CHURCH, VA:
2,967,874, CANC. INT. CL. 9.
- TEAM FAIR HOLDINGS LIMITED, ROAD TOWN, BR. VIRGIN ISLANDS:
2,737,304, CANC. INT. CL. 20.
- TEAM FINANCIAL ASSET MANAGEMENT LLC, HARRISBURG, PA:
4,117,540, PUB. 10-4-2011. INT. CL. 36.
- TEC FOODS, INC., CHICAGO, IL:
4,118,631, PUB. 1-10-2012. INT. CL. 30.
- TECH-MED SERVICES INC., SMITHTOWN, NY:
4,118,759, MULTIPLE CLASS, INT. CLS. 9, 10, 16, 20 AND 21.
- TECH-MED SERVICES, INC., SMITHTOWN, NY:
4,118,758, MULTIPLE CLASS, INT. CLS. 9, 10, 16, 20 AND 21.
- TECHNICAL SALES INTERNATIONAL, LLC, CITRUS HEIGHTS, CA:
4,117,087, PUB. 1-10-2012. INT. CL. 9.
- TECHNOLOGICAL RESOURCES PTY. LIMITED, MELBOURNE, AUSTRALIA:
4,117,048, PUB. 1-10-2012. MULTIPLE CLASS, INT. CLS. 6 AND 11.
- TECOMATE WILDLIFE SYSTEMS, LTD., SAN ANTONIO, TX:
2,467,615, CANC. INT. CL. 7.
- TEGRA GROUP, INC., THE, MINNEAPOLIS, MN:
2,585,221, REN. 2-23-12. INT. CL. 36.
- TEKNI-PLEX INC., SOMERVILLE, NY:
926,056, REN. 2-21-12. U.S. CL. 1 (INT. CL. 17).
- TEKNION LLC, MOUNT LAUREL, NJ, TEKNION LLC, MOUNT LAUREL, NJ:
2,483,380, REN. 2-17-12. INT. CL. 20.
- TELECOM VENTURE GROUP LIMITED, CENTRAL, HONG KONG:
2,959,482, CANC. INT. CL. 36.
- TELEDYNE GAVIA EHF, KÓPAVOGUR, ICELAND, FORMERLY HAFMYND EHF:
4,117,602, PUB. 1-10-2012. INT. CL. 12.
- TELEFLEX INCORPORATED, LIMERICK, PA:
2,531,847, REN. 2-17-12. INT. CL. 10.
- TELEVISA, S.A. DE C.V., SANTA FE, MEXICO:
4,118,721, PUB. 1-10-2012. INT. CL. 41.
4,118,725, PUB. 1-10-2012. MULTIPLE CLASS, INT. CLS. 9 AND 41.
4,118,729, PUB. 1-10-2012. INT. CL. 41.
- TELIGENCE (US), INC., VANCOUVER, CANADA:
2,667,475, REN. 2-21-12. INT. CL. 42.
- TELIGENCE (US), LLC, VANCOUVER, CANADA:
2,670,065, REN. 2-21-12. INT. CL. 38.

TELLME NETWORKS, INC., MOUNTAIN VIEW, CA:
2,968,005, CANC. MULTIPLE CLASS, INT. CLS. 35, 38 AND 42.

TEMBEC USA LLC, ST. FRANCISVILLE, LA:
2,968,086, CANC. INT. CL. 16.

TENACITY GROUP, LLC, GREENBELT, MD:
2,968,534, CANC. MULTIPLE CLASS, INT. CLS. 35, 37 AND 42.

TENHOOR & HELFFRICH, WASHINGTON, DC:
2,529,344, CANC. INT. CL. 35.

TENNIS CORPORATION OF AMERICA, CHICAGO, IL:
1,677,913, REN. 2-22-12. INT. CL. 41.

TENNIS FIENDS INC., BERKELEY, CA:
4,119,644, INT. CL. 25.

TENSOLITE, LLC, SAINT AUGUSTINE, FL:
4,116,897, PUB. 1-10-2012. INT. CL. 9.

TERREL H. BELL AND ASSOCIATES, EDUCATIONAL CONSULTANTS, SALT LAKE CITY, UT:
2,908,984, CANC. INT. CL. 41.

TERRENO RESOURCES CORP., VANCOUVER, BC, CANADA:
4,119,206, MULTIPLE CLASS, INT. CLS. 37 AND 42.

TERRY HARRIS, CORDOVA, TN:
4,119,431, INT. CL. 30.

TERRY L. WIKE, LAS VEGAS, NV:
4,119,179, INT. CL. 9.

TESSENDERLO KERLEY, INC., PHOENIX, AZ, KERLEY, INC., SAHUARITA, AZ:
1,753,088, REN. 2-21-12. INT. CL. 1.

TEXANS CREDIT UNION, RICHARDSON, TX:
2,629,755, REN. 2-17-12. INT. CL. 36.

TEXAS FARM PRODUCTS COMPANY, NACOGDOCHES, TX, DBA TEXAS FARM PRODUCTS COMPANY, TEXAS FARM PRODUCTS COMPANY, NACOGDOCHES, TX:
1,707,085, REN. 2-22-12. INT. CL. 31.

TEXAS HIGHER EDUCATION COORDINATING BOARD, AUSTIN, TX:
4,119,877, INT. CL. 35.
4,119,878, INT. CL. 35.
4,119,883, INT. CL. 41.
4,119,884, INT. CL. 41.
4,119,885, INT. CL. 35.
4,119,886, INT. CL. 41.

TEXAS MOVING CO., INC., RICHARDSON, TX:
1,718,825, REN. 2-22-12. INT. CL. 39.

TEXPAR ENERGY, L.L.C., ONALASKA, WI:
4,118,745, PUB. 1-10-2012. MULTIPLE CLASS, INT. CLS. 4, 19, 37 AND 39.

TEXTS FROM LAST NIGHT, INC., BIRMINGHAM, MI:
4,118,594, PUB. 1-10-2012. INT. CL. 9.

TEXTURED COATINGS OF AMERICA INC., PANAMA CITY, FL:
2,665,847, REN. 2-22-12. INT. CL. 2.

TEXTURED COATINGS OF AMERICA, INC., LOS ANGELES, CA:
2,669,520, REN. 2-22-12. INT. CL. 2.

TH REMODELING & RENOVATIONS, INC., WALDEN, NY:
4,118,562, PUB. 1-10-2012. INT. CL. 37.

THAI WORLD IMPORT & EXPORT CO., LTD., BANGKOK 10120, THAILAND:
4,118,963, MULTIPLE CLASS, INT. CLS. 29 AND 30.

THE ALFRED E. MANN FOUNDATION FOR SCIENTIFIC RESEARCH, VALENCIA, CA:
4,117,679, PUB. 1-10-2012. INT. CL. 42.

THE ALLEY HOUSE, LLC, PAGOSA SPRINGS, CO:
4,118,336, PUB. 1-10-2012. INT. CL. 36.

THE ANNIE E. CASEY FOUNDATION, INC., BALTIMORE, MD:
4,117,586, PUB. 1-10-2012. MULTIPLE CLASS, INT. CLS. 16 AND 45.

THE ATLANTIC MONTHLY GROUP, INC., WASHINGTON, DC:
4,118,392, PUB. 1-10-2012. MULTIPLE CLASS, INT. CLS. 41 AND 42.

THE ATUM GROUP, LLC, PORTLAND, OR, DBA THE ATUM GROUP:
4,117,845, PUB. 1-10-2012. INT. CL. 35.

THE AYERS FOUNDATION, PARSONS, TN:
4,116,580, PUB. 1-10-2012. INT. CL. 41.

THE BANK OF NOVA SCOTIA, TORONTO, ONTARIO, CANADA:
4,116,962, PUB. 1-10-2012. INT. CL. 36.

THE BASIS POINT, INC., SAN FRANCISCO, CA:
4,117,645, PUB. 1-10-2012. MULTIPLE CLASS, INT. CLS. 36 AND 41.
4,117,646, PUB. 1-10-2012. INT. CL. 35.

THE BETTY MILLS COMPANY, INC., SANTA BARBARA, CA:
4,117,164, PUB. 1-10-2012. INT. CL. 35.

THE BILL POLICE, INC., RICHMOND, VA:
4,116,920, PUB. 1-10-2012. INT. CL. 35.

THE BIOMECHANICS LLC, SAN DIEGO, CA:
4,119,846, INT. CL. 9.

THE BODY PRINCIPLE, LLC, ORION, MI:
2,911,353, CANC. INT. CL. 41.

THE BOK TOWER GARDENS FOUNDATION, INC., LAKE WALES, FL, DBA BOK TOWER GARDENS:
4,117,652, PUB. 1-10-2012. INT. CL. 41.

THE BRITISH BROADCASTING CORPORATION, LONDON, UNITED KINGDOM:
4,116,916, PUB. 1-10-2012. MULTIPLE CLASS, INT. CLS. 9, 28 AND 41.

THE BRITISH DISPENSARY (L.P.) CO., LTD., SAMUTPRAKARN, THAILAND:
4,117,529, PUB. 1-10-2012. MULTIPLE CLASS, INT. CLS. 3 AND 5.

THE CADENCE GROUP, INC., ATLANTA, GA:
4,119,784, INT. CL. 42.

THE CAPITAL GROUP COMPANIES, INC., LOS ANGELES, CA:
4,119,853, INT. CL. 36.

THE CARTOON NETWORK LP, LLLP, ATLANTA, GA:
2,967,725, CANC. INT. CL. 28.

THE CENTER FOR CITIZEN LEADERSHIP, ST. LOUIS, MO:
4,118,465, PUB. 1-10-2012. INT. CL. 35.

THE CHENILLE KRAFT COMPANY, GURNEE, IL:
4,119,322, INT. CL. 28.

THE CHICKEN DONUT, LLC, BOSTON, MA:
4,117,499, PUB. 1-10-2012. INT. CL. 41.
4,117,500, PUB. 1-10-2012. INT. CL. 41.
4,117,502, PUB. 1-10-2012. INT. CL. 41.

THE CIRCLE GROUP INC., LOS ANGELES, CA:
4,119,659, INT. CL. 25.

THE CLUB FOUNDATION, ALEXANDRIA, VA:
2,663,125, REN. 2-21-12. INT. CL. 36.

THE COLEMAN COMPANY, INC., WICHITA, KS:
4,117,003, PUB. 1-10-2012. INT. CL. 20.
4,117,004, PUB. 1-10-2012. INT. CL. 20.
4,117,005, PUB. 1-10-2012. INT. CL. 20.

THE COLLABORATIVE LAW ASSOCIATION, ST. LOUIS, MO:
4,118,526, PUB. 1-10-2012. INT. CL. 35.

THE COLLECTIVE MANAGEMENT GROUP, BEVERLY HILLS, CA:
4,117,269, PUB. 1-10-2012. MULTIPLE CLASS, INT. CLS. 9 AND 35.

THE CONGRESSIONAL DIGEST CORPORATION, WASHINGTON, DC:
4,117,352, PUB. 1-10-2012. INT. CL. 9.

THE CONNECTED TABLE, INC., NEW YORK, NY:
4,119,485, INT. CL. 35.
4,119,486, INT. CL. 35.

THE CORPORATE EXECUTIVE BOARD, INC., NEW YORK, NY:
4,117,637, PUB. 1-10-2012. MULTIPLE CLASS, INT. CLS. 35 AND 41.

THE COUNTY OF NASSAU, AMELIA ISLAND, FL:
4,118,019, PUB. 1-10-2012. INT. CL. 35.

THE CURATORS OF THE UNIVERSITY OF MISSOURI, KANSAS CITY, MO, DBA KCSOURCELINK:
2,968,610, CANC. INT. CL. 35.

THE DALLAS CONVENTION & VISITORS BUREAU, DALLAS, TX:
4,119,407, INT. CL. 35.

- THE DATA CENTER, INC., YADKINVILLE, NC:
4,118,842, INT. CL. 9.
- THE DESIGN CLUB INC., BOCA RATON, FL:
4,117,721, PUB. 1-10-2012. INT. CL. 42.
- THE DIAL CORPORATION, SCOTTSDALE, AZ:
4,119,124, INT. CL. 3.
- THE DORA KAN GROUP, LLC, WASHINGTON, DC:
4,118,424, PUB. 1-10-2012. INT. CL. 35.
- THE EXAMPLE FOR LEADING OUR NATION LLC,
ATLANTA, GA:
4,118,953, INT. CL. 25.
- THE EXECUTIVE ARENA, INC., CHARLOTTE, NC:
4,118,359, PUB. 1-10-2012. INT. CL. 33.
- THE F. L. EMMERT CO., CINCINNATI, OH:
4,119,370, MULTIPLE CLASS, INT. CLS. 5 AND 31.
- THE FRESH ICE CREAM COMPANY, LLC, HOLBROOK,
NY:
1,158,272, REN. 2-21-12. INT. CL. 30.
- THE GENERAL ASSEMBLY OF SPIRITUALISTS, ROCHE-
STER, NY:
4,117,325, PUB. 1-10-2012. INT. CL. 16.
- THE GENERAL COUNCIL OF THE ASSEMBLIES OF GOD,
SPRINGFIELD, MO:
4,117,672, PUB. 1-10-2012. MULTIPLE CLASS, INT. CLS.
9, 16, 25, 26 AND 41.
- THE GOLF FASHION COMPANY, INHABER PRODROMOS
TSARNOS, REUTLINGEN, FED REP GERMANY:
4,116,698, PUB. 1-10-2012. MULTIPLE CLASS, INT. CLS.
18 AND 25.
- THE GUARDIAN LIFE INSURANCE COMPANY OF AMER-
ICA, NEW YORK, NY:
4,117,627, PUB. 1-10-2012. INT. CL. 36.
- THE GUESS GROUP, INC., HOUSTON, TX AND JOHN L.
GUESS, HOUSTON, TX:
4,116,601, PUB. 11-11-2008. INT. CL. 36.
- THE HARTZ MOUNTAIN CORPORATION, SECAUCUS, NJ:
4,119,220, INT. CL. 31.
- THE HEALTHIER WAY INSTITUTE, LLC, DELRAY
BEACH, FL:
4,119,429, INT. CL. 44.
- THE HOEFLER TYPE FOUNDRY, INC., NEW YORK, NY,
DBA HOEFLER & FRERE-JONES:
4,117,145, PUB. 1-10-2012. INT. CL. 9.
- THE HOGANS AGENCY, INC., CHESTERTOWN, MD:
4,117,533, PUB. 1-10-2012. INT. CL. 36.
- THE HR TEAM, LLC, COLUMBIA, MD:
2,467,939, CANC. INT. CL. 35.
- THE INSPIRATIONAL NETWORK, INC., INDIAN LAND,
SC:
4,118,289, PUB. 1-10-2012. INT. CL. 38.
- THE INTERNATIONAL TOILETRY COMPANY, INC.,
BOCA RATON, FL, SOMERSET TOILETRY COMPANY
LIMITED, THE, CLUTTON, SOMERSET, UNITED KING-
DOM:
2,527,784, REN. 2-22-12. INT. CL. 3.
- THE JOURNEY THROUGH HALLOWED GROUND PART-
NERSHIP, WATERFORD, VA:
4,117,007, PUB. 1-10-2012. MULTIPLE CLASS, INT. CLS.
35 AND 41.
- 4,117,008, PUB. 1-10-2012. MULTIPLE CLASS, INT. CLS.
35 AND 41.
- THE JUNK REMOVERS, INC., DEDHAM, MA:
4,117,900, PUB. 1-10-2012. INT. CL. 39.
- THE KAYLYN ELAINE WARREN FOUNDATION, NEW-
ARK, DE:
4,117,657, PUB. 1-10-2012. INT. CL. 36.
- THE KELVIN CONSULTANTS LIMITED, FAIRLIE, AYR-
SHIRE, UNITED KINGDOM:
4,116,937, PUB. 6-21-2011. MULTIPLE CLASS, INT. CLS.
9, 16, 41 AND 45.
- THE KONG COMPANY, GOLDEN, CO:
4,119,568, INT. CL. 28.
- THE LEARNING JUNCTION LIMITED, PORIRUA 5026,
NEW ZEALAND:
4,117,445, PUB. 1-10-2012. MULTIPLE CLASS, INT. CLS.
16 AND 41.
- THE LEO PETERS LIVING TRUST, GRAND RAPIDS, MI:
4,117,067, PUB. 1-10-2012. INT. CL. 29.
- THE LINC GROUP, LLC, HOUSTON, TX:
4,116,954, PUB. 1-10-2012. MULTIPLE CLASS, INT. CLS.
35, 41 AND 45.
- THE LOVER SQUIRREL, LLC, CLARKSBURG, WV:
4,119,349, INT. CL. 45.
- THE LUCCI CORP., PETERBOROUGH, NH:
4,118,977, MULTIPLE CLASS, INT. CLS. 18 AND 20.
- THE LYMPHATIC MALFORMATION INSTITUTE,
BETHESDA, MD:
4,119,779, INT. CL. 36.
- THE MAJESTIC STAR CASINO, LLC, GARY, IN, FITZGER-
ALDS RENO, INC., RENO, NV:
1,676,148, REN. 2-22-12. INT. CL. 41.
- THE MARCIA E. HORSTMAN AND JONATHAN W.
HORSTMAN PARTNERSHIP, CULLOWHEE, NC:
4,119,119, INT. CL. 24.
- THE MILLS LIMITED PARTNERSHIP, CHEVY CHASE, MD:
2,967,978, CANC. INT. CL. 36.
- THE MULLER GROUP, INC., CHARLOTTE, NC, DBA
PROSTEAD REALTY:
4,118,341, PUB. 1-10-2012. INT. CL. 36.
- THE MUSIC PEOPLE INC., BERLIN, CT:
4,118,749, PUB. 9-6-2011. INT. CL. 15.
- THE NATIONAL RENTERS ASSOCIATION, INC., SEGUIN,
TX:
4,119,776, INT. CL. 9.
- THE NIKKA WHISKY DISTILLING CO., LTD., TOKYO,
JAPAN:
4,117,693, PUB. 1-10-2012. INT. CL. 33.
- THE NURTURING NOOK, INC., GLENDALE, WI:
4,117,061, PUB. 1-10-2012. MULTIPLE CLASS, INT. CLS.
43 AND 45.
- THE O'DELL CORPORATION, WARE SHOALS, SC:
4,117,598, PUB. 1-10-2012. INT. CL. 21.
- THE OCTOPUS COMPANY, NAAMLOZE VEN-
NOOTSCHAP, BELGIUM:
4,116,729, PUB. 1-10-2012. MULTIPLE CLASS, INT. CLS.
9, 16 AND 36.
- THE ORIGINAL BRADFORD SOAP WORKS, INC., WEST
WARWICK, RI:
2,967,914, CANC. INT. CL. 3.
- THE ORIGINAL LITTLE SPROUT, LLC, ATASCADERO,
CA:
3,198,844, COR. INT. CL. 3.
- THE OUTDOOR RECREATION GROUP, LOS ANGELES,
CA:
4,118,123, PUB. 1-10-2012. INT. CL. 21.
- THE PILLSBURY COMPANY, MINNEAPOLIS, MN:
2,968,032, CANC. INT. CL. 30.
- THE PILLSBURY COMPANY, LLC, MINNEAPOLIS, MN:
296,115, REN. 2-21-12. U.S. CL. 46 (INT. CL. 30).
- THE PLUMERIA TREE, LLC, TUCSON, AZ:
4,117,728, PUB. 1-10-2012. INT. CL. 14.
- THE PRETTY KITTY, INC., HENDERSON, NV:
4,118,454, PUB. 1-10-2012. INT. CL. 44.
- THE PRINCETON REVIEW, INC., FRAMINGHAM, MA:
2,519,256, REN. 2-21-12. INT. CL. 41.
- THE PRINTER PROJECT, SHAKER HEIGHTS, OH, DBA
KNOWTA:
4,118,390, PUB. 1-10-2012. MULTIPLE CLASS, INT. CLS.
35, 38 AND 40.
- THE PROCTER & GAMBLE COMPANY, CINCINNATI, OH:
4,118,214, PUB. 1-10-2012. INT. CL. 16.
- 4,118,561, PUB. 1-10-2012. INT. CL. 3.
- 4,119,389, INT. CL. 3.
- THE PRUDENTIAL INSURANCE COMPANY OF AMER-
ICA, NEWARK, NJ:
4,118,896, INT. CL. 36.
- THE QUALITY COMPANIES, INC., TALLAHASSEE, FL:
4,117,254, PUB. 1-10-2012. INT. CL. 43.
- THE RANDOM ACTS OF KINDNESS FOUNDATION,
DENVER, CO:
4,119,103, INT. CL. 9.
- THE RECLAIM GROUP, LLC, BETHESDA, MD:
4,118,026, PUB. 1-10-2012. INT. CL. 35.
- THE RECONCILIATION CENTRE, NFP, KANKAKEE, IL:
4,118,478, PUB. 1-10-2012. INT. CL. 41.

- THE RITZ-CARLTON HOTEL COMPANY, L.L.C., BETHESDA, MD:
4,118,797, INT. CL. 36.
- THE RIVERTOWN BREWING COMPANY, LLC, LOCKLAND, OH:
4,118,104, PUB. 1-10-2012. INT. CL. 32.
- THE SAILTIME GROUP, LLC, ANNAPOLIS, MD:
4,117,476, PUB. 1-10-2012. MULTIPLE CLASS, INT. CLS. 35, 36, 39 AND 41.
- THE SAINT AUGUSTINE LIGHTHOUSE AND MUSEUM, INC., ST. AUGUSTINE, FL:
4,119,553, INT. CL. 25.
- THE SCHOOL BOARD OF MIAMI-DADE COUNTY, MIAMI, FL:
4,117,016, PUB. 1-10-2012. INT. CL. 41.
- THE SEAT OF THE HAMPTONS LLC, HAMPTON BAYS, NY:
1,194,474, REN. 2-17-12. INT. CL. 42.
- THE SECOND CUP COFFEE COMPANY INC., ONTARIO, CANADA:
2,552,932, REN. 2-23-12. INT. CL. 35.
- THE SHARPS RIFLE COMPANY, LLC, SAINT CHARLES, MO, FORMERLY MHB ENTERPRISES:
4,117,160, PUB. 1-10-2012. MULTIPLE CLASS, INT. CLS. 8 AND 13.
- THE SOLEFULL LOUNGE, HYDE PARK, MA:
4,117,110, PUB. 1-10-2012. MULTIPLE CLASS, INT. CLS. 25 AND 35.
- THE STREET MEDICINE INSTITUTE, ALLISON PARK, PA:
4,117,009, PUB. 1-10-2012. MULTIPLE CLASS, INT. CLS. 41 AND 44.
- THE SUDDATH COMPANIES, JACKSONVILLE, FL:
4,117,990, PUB. 1-10-2012. MULTIPLE CLASS, INT. CLS. 35, 36 AND 39.
- THE SUPER DENTISTS, INC., CHULA VISTA, CA:
4,118,450, PUB. 1-10-2012. INT. CL. 44.
- THE SUSAN G. KOMEN BREAST CANCER FOUNDATION, INC., DALLAS, TX:
4,119,755, INT. CL. 36.
- THE TALBOTS GROUP, LIMITED PARTNERSHIP, HINGHAM, MA:
2,947,688, CANC. INT. CL. 25.
- THE TAYLOR GROUP, INC., LOUISVILLE, MS:
4,118,756, INT. CL. 9.
- THE TEA LAB, LLC, NEW YORK, NY:
4,118,490, PUB. 1-10-2012. INT. CL. 30.
- THE TEMPLAR COMPANY LIMITED, DORKING, SURREY, UNITED KINGDOM:
3,057,084, CANC. MULTIPLE CLASS, INT. CLS. 24 AND 25.
- THE TEMPLE OF SELF-ASCENSION, SILVER SPRINGS, NV:
4,118,385, PUB. 1-10-2012. INT. CL. 41.
- THE TJX COMPANIES, INC., FRAMINGHAM, MA:
2,968,551, CANC. INT. CL. 26.
4,117,366, PUB. 1-10-2012. INT. CL. 8.
4,117,367, PUB. 1-10-2012. MULTIPLE CLASS, INT. CLS. 18 AND 20.
4,117,375, PUB. 1-10-2012. INT. CL. 21.
- THE TOLI GROUP, WESTLAKE, OH:
4,117,284, PUB. 1-10-2012. MULTIPLE CLASS, INT. CLS. 36 AND 39.
- THE TRAVELERS INDEMNITY COMPANY, HARTFORD, CT:
4,119,597, INT. CL. 36.
- THE TRUSTEE OF THE MICHAEL H. COON REVOCABLE TRUST, LOHRVILLE, IA:
4,118,108, PUB. 1-10-2012. INT. CL. 42.
- THE TRUSTEES OF INDIANA UNIVERSITY, BLOOMINGTON, IN:
4,117,678, PUB. 1-10-2012. INT. CL. 41.
- THE UNIVERSITY OF HOUSTON SYSTEM, HOUSTON, TX:
4,116,569, PUB. 1-10-2012. MULTIPLE CLASS, INT. CLS. 16, 25 AND 41.
- THE UNIVERSITY OF NEW MEXICO, ALBUQUERQUE, NM:
4,119,380, MULTIPLE CLASS, INT. CLS. 25 AND 41.
- THE UNIVERSITY OF NORTH CAROLINA AT CHAPEL HILL, CHAPEL HILL, NC:
2,527,161, REN. 2-22-12. INT. CL. 41.
- THE UPPER DECK COMPANY, INC., CARLSBAD, CA:
1,671,098, REN. 2-23-12. INT. CL. 16.
- THE UPPER SKAGIT INDIAN TRIBE, BOW, WA, DBA SKAGIT VALLEY CASINO RESORT:
4,117,435, PUB. 1-10-2012. INT. CL. 41.
- THE W. E. BASSETT COMPANY, SHELTON, CT:
952,167, REN. 2-21-12. U.S. CL. 44 (INT. CL. 8).
- THE WASHINGTON TIMES LLC, WASHINGTON, DC:
4,119,816, INT. CL. 41.
- THE WESTERNER SILVER SHOP AND TROPHY CENTER, INC., RENO, NV:
4,118,227, PUB. 1-10-2012. INT. CL. 40.
- THE WILLIAMSBURG GARMENT COMPANY, BROOKLYN, NY, AKA WILLIAMSBURG GARMENT COMPANY:
4,119,794, INT. CL. 25.
- THE WILSON DAILY TIMES, INC., WILSON, NC:
2,968,287, CANC. INT. CL. 35.
- THERAPIPE LLC, SAN DIEGO, CA:
4,116,553, PUB. 1-10-2012. INT. CL. 5.
- THERE GOES MY HERO, INC., BEL AIR, MD:
4,119,027, MULTIPLE CLASS, INT. CLS. 35 AND 36.
4,119,028, MULTIPLE CLASS, INT. CLS. 35 AND 36.
4,119,034, MULTIPLE CLASS, INT. CLS. 35 AND 36.
- THERMACTIVE ELECTRONICS LLC, MERCER ISLAND, WA:
4,117,819, PUB. 1-10-2012. INT. CL. 11.
- THERMO FISHER SCIENTIFIC (ASHEVILLE) LLC, WALTHAM, MA:
2,534,599, REN. 2-23-12. INT. CL. 7.
- THETA ENTERPRISES INC., MOUNT HOLLY, NJ, DBA HITECHTRADER.COM:
4,118,207, PUB. 1-10-2012. INT. CL. 35.
- THINKINGIQ LLC, HIGHLANDS RANCH, CO:
4,119,236, MULTIPLE CLASS, INT. CLS. 16 AND 35.
- THINSITE, LLC, MANHASSET, NY:
4,117,053, PUB. 1-10-2012. INT. CL. 9.
- THOEL COMPANY LLC, NEW YORK, NY:
2,967,580, CANC. INT. CL. 25.
- THOIP, LONDON, UNITED KINGDOM:
4,116,593, PUB. 11-23-2010. MULTIPLE CLASS, INT. CLS. 9, 16, 25, 28 AND 41.
- THOLSTRUP CHEESE A/S, VIBY J, DENMARK:
2,467,305, CANC. INT. CL. 29.
- THOMAS GROUP, INC., IRVING, TX:
2,468,309, CANC. INT. CL. 35.
- THOMAS NELSON, INC., NASHVILLE, TN:
4,118,621, PUB. 1-10-2012. INT. CL. 16.
- THOMPSON, TAMMY L, CHICAGO, IL, DBA LITTLE MISS PATCH IT:
4,117,740, PUB. 1-10-2012. INT. CL. 26.
- THOR TECH, INC., JACKSON CENTER, OH:
4,118,841, MULTIPLE CLASS, INT. CLS. 9 AND 14.
- THREE BROTHERS WINERY & ESTATES LLC, GENEVA, NY:
4,117,664, PUB. 1-10-2012. INT. CL. 33.
4,117,665, PUB. 1-10-2012. INT. CL. 33.
4,117,667, PUB. 1-10-2012. INT. CL. 33.
4,117,668, PUB. 1-10-2012. INT. CL. 33.
- THRIVENT FINANCIAL FOR LUTHERANS, APPLETON, WI:
4,118,985, INT. CL. 35.
- THUASNE, 92307 LEVALLOIS-PERRET CEDEX, FRANCE:
2,965,444, CANC. INT. CL. 10.
- THYMPLY PRODUCTS, INC., COLORA, MD:
1,198,392, REN. 2-17-12. MULTIPLE CLASS, INT. CLS. 1 AND 30.
- THYSSENKRUPP ELEVATOR CAPITAL CORPORATION, TROY, MI:
2,968,370, CANC. INT. CL. 9.
- TIDAL ENERGY MARKETING, INC., CALGARY, ALBERTA, CANADA:
2,538,784, REN. 2-22-12. MULTIPLE CLASS, INT. CLS. 36 AND 39.
- TIDEWORKS TECHNOLOGY, INC., SEATTLE, WA:
4,119,502, INT. CL. 9.

- TIDI PRODCUTS, LLC, NEENAH, WI, VERATEX CORPORATION, THE, TROY, MI:
1,687,078. REN. 2-22-12. INT. CL. 10.
- TIFCO INDUSTRIES, INC., CYPRESS, TX:
4,119,691, INT. CL. 7.
- TIFFANY J. BURRESS, TOTOWA, NJ:
4,118,772, INT. CL. 25.
- TIGER VALUATION SERVICES LLC, WESTLAKE VILLAGE, CA:
4,118,451, PUB. 1-10-2012. INT. CL. 35.
4,118,467, PUB. 1-10-2012. INT. CL. 35.
- TILE MEDIA PROPERTIES, INC., ATLANTA, GA:
4,116,936, PUB. 1-18-2011. INT. CL. 5.
- TIMCAL SA (TIMCAL AG) (TIMCAL LTD), BODIO, SWITZERLAND:
2,968,270, CANC. INT. CL. 1.
- TIMOTHY C VERHAREN, DDS, PLLC, BREMERTON, WA:
4,118,015, PUB. 1-10-2012. INT. CL. 44.
- TINO WALLEANDA-ZOPPE, SARASOTA, FL:
1,643,047. REN. 2-23-12. INT. CL. 41.
- TIPPINS, AMY NICOLE, NORCROSS, GA, DBA ROCKSCAR LOVE DESIGNS:
4,118,138, PUB. 1-10-2012. INT. CL. 25.
- TIR TECHNOLOGY LP, BURNABY, BRITISH COLUMBIA, CANADA:
2,968,117, CANC. INT. CL. 11.
- TIRE MART, INC., ST. LOUIS, MO:
4,119,248, MULTIPLE CLASS, INT. CLS. 18 AND 25.
- TISSOT SA, 2400 LE LOCLE, SWITZERLAND:
4,119,062, INT. CL. 14.
- TLB HOLDINGS, INC., PLYMOUTH, MN:
4,118,764, INT. CL. 25.
- TLV CORPORATION, CHARLOTTE, NC:
2,492,863. REN. 2-17-12. INT. CL. 9.
- TOAS-TITE LLC, DR. HOFFMAN ESTATES, IL:
4,119,467, INT. CL. 21.
- TOLEDO BABY, LLC, TOLEDO, OH:
4,117,013, PUB. 1-10-2012. INT. CL. 42.
- TOMLIN AIR CORP., OYSTER BAY, NY:
2,968,589, CANC. INT. CL. 39.
- TOMTOM INTERNATIONAL B.V., AMSTERDAM, NETHERLANDS:
4,116,636, PUB. 1-10-2012. MULTIPLE CLASS, INT. CLS. 9, 39 AND 42.
- TOMTOM INTERNATIONAL B.V., NETHERLANDS:
4,116,679, PUB. 1-10-2012. MULTIPLE CLASS, INT. CLS. 9, 38 AND 39.
- TOO FACED COSMETICS, INC., IRVINE, CA:
4,117,855, PUB. 1-10-2012. INT. CL. 3.
4,117,931, PUB. 1-10-2012. INT. CL. 3.
4,118,677, PUB. 1-10-2012. INT. CL. 3.
- TOOTSIE ROLL INDUSTRIES, LLC, CHICAGO, IL:
2,664,052. REN. 2-22-12. INT. CL. 30.
- TOP RANK INC., LAS VEGAS, NV:
4,116,943, PUB. 1-10-2012. INT. CL. 25.
- TOP TOBACCO L.P., GLENVIEW, IL:
4,118,735, PUB. 1-10-2012. INT. CL. 34.
- TOPWIN CORPORATION, TORRANCE, CA:
2,660,357. REN. 2-17-12. INT. CL. 25.
- TORI MCKINNEY, LLC, FALLS CHURCH, VA:
4,118,009, PUB. 1-10-2012. INT. CL. 36.
- TORINO, KENNETH, COLCHESTER, VT:
4,119,343, INT. CL. 7.
- TORRES JR. - CATANESE, JOHN ANDREW, NANUET, NY:
4,117,448, PUB. 1-10-2012. INT. CL. 41.
- TOTALCAD COMERCIO E SERVIÇOS EM INFORMATICA LTDA, SAO PAULO, BRAZIL:
4,119,592, INT. CL. 42.
- TOTO U.S.A., INC., MORROW, GA:
2,967,678, CANC. INT. CL. 11.
- TOUCAKE LLC, LAWRENCEVILLE, GA:
4,118,428, PUB. 1-10-2012. INT. CL. 30.
- TOURISM BRITISH COLUMBIA, VICTORIA, BRITISH COLUMBIA, V8W 9W5, CANADA:
2,466,994, CANC. MULTIPLE CLASS, INT. CLS. 39, 41 AND 42.
- TOYLOGIC INC., TOKYO, JAPAN:
4,116,850, PUB. 1-10-2012. MULTIPLE CLASS, INT. CLS. 9 AND 41.
- TR THEATER RESEARCH, INC., CYPRESS, CA:
4,119,629, INT. CL. 9.
- TRACKER MARINE, L.L.C., SPRINGFIELD, MO, TRACKER MARINE CORPORATION, SPRINGFIELD, MO:
1,674,981. REN. 2-17-12. INT. CL. 12.
- TRACY FOODS, INC., BELMONT, MA:
2,623,436. REN. 2-21-12. INT. CL. 29.
- TRADE SERVICE COMPANY, LLC, SAN DIEGO, CA:
4,119,798, MULTIPLE CLASS, INT. CLS. 9 AND 42.
- TRADEMARKS LLC, RICHMOND, VA:
2,531,228. REN. 2-23-12. INT. CL. 34.
- TRADESIGNAL GMBH, FED REP GERMANY:
4,116,764, PUB. 1-10-2012. MULTIPLE CLASS, INT. CLS. 9, 16, 42 AND 45.
- TRAIL BLAZERS, INC., PORTLAND, OR:
2,968,037, CANC. INT. CL. 18.
- TRAINING GROUNDS LLC, SHARPSBURG, KY:
2,968,208, CANC. MULTIPLE CLASS, INT. CLS. 14, 16, 25 AND 28.
- TRAN, CHINH N, COLUMBIA, MD:
2,968,218, CANC. INT. CL. 25.
- TRANS AMERICAN MUSCLE, LLC, CORAL SPRINGS, FL:
4,118,184, PUB. 1-10-2012. INT. CL. 37.
- TRANS FAMILY, INC., SAN GABRIEL, CA:
2,667,044. REN. 2-22-12. INT. CL. 30.
- TRANSCATHETER TECHNOLOGIEES GMBH, 93053 REGENSBURG, FED REP GERMANY:
4,119,747, INT. CL. 10.
- TRANSFAIR NORTH AMERICA INTERNATIONAL FREIGHT SERVICES, INC., SEATTLE, WA:
2,467,320, CANC. INT. CL. 39.
- TRANSOL CORPORATION, MORGANTOWN, PA, LINCOLN PRECISION MACHINING COMPANY-HOIST DIVISION, NORTH GRAFTON, MA:
552,776. REN. 2-22-12. U.S. CL. 23 (INT. CL. 7).
- TRAVEL CADDY, INC., ELK GROVE VILLAGE, IL:
2,968,522, CANC. INT. CL. 20.
- TRAVEL CADDY, INC., ELK GROVE VILLAGE, IL, DBA TRAVELON:
4,119,274, INT. CL. 18.
- TRAVEL THE GORGE, LLC, HOOD RIVER, OR, AKA TRAVELTHEGORGE.COM, GRAVES; ORVILLE R., MERCER ISLAND, WA, DBA SNOQUALMIE FALLS LODGE:
1,192,225. REN. 2-21-12. INT. CL. 30.
- TRAVELING CHIC BOUTIQUE, LLC, SOUTHERN PINES, NC:
4,118,042, PUB. 1-10-2012. INT. CL. 35.
- TRAVIS BODY & TRAILER, INC., HOUSTON, TX:
4,118,636, PUB. 1-10-2012. INT. CL. 12.
4,118,638, PUB. 1-10-2012. INT. CL. 12.
- TREE T PEE, LLC, SARASOTA, FL:
4,117,326, PUB. 1-10-2012. INT. CL. 11.
- TRI GLOBAL ENTERPRISES, INC., MINNETONKA, MN:
4,117,882, PUB. 1-10-2012. MULTIPLE CLASS, INT. CLS. 6, 7, 8, 9 AND 20.
- TRI-STARCO, INC., STAFFORD, TX:
4,116,578, PUB. 1-10-2012. INT. CL. 33.
- TRIAGE CONSULTING GROUP, SAN FRANCISCO, CA:
4,118,335, PUB. 1-10-2012. INT. CL. 35.
- TRIBALLAT NOYAL, F-35530 NOYAL-SUR-VILAINE, FRANCE:
4,116,694, PUB. 1-10-2012. MULTIPLE CLASS, INT. CLS. 29 AND 30.
- TRIBRIDGE RESIDENTIAL, LLC, ATLANTA, GA:
4,119,406, MULTIPLE CLASS, INT. CLS. 36 AND 37.
- TRICAM INDUSTRIES, INC., MINNEAPOLIS, MN:
2,967,338, CANC. INT. CL. 6.
- TRIEU, LLC, NASHVILLE, TN:
3,192,012 NEW CERT. 3-27-2012. INT. CL. 44.
- TRIGLOBE INTERNATIONAL, INC., LITTLE FERRY, NJ:
4,118,012, PUB. 1-10-2012. INT. CL. 25.
- TRILOGY INTERNATIONAL, INC., DEARBORN, MI:
2,965,413, CANC. INT. CL. 42.
- TRIM SCENE SOLUTIONS, INC., REDWAY, CA:
4,118,192, PUB. 1-10-2012. MULTIPLE CLASS, INT. CLS. 35 AND 37.

TRIMARCHI, HELENE, BROOKLYN, NY AND MERR, MICHAEL, BROOKLYN, NY:
4,118,788, INT. CL. 25.

TRINIDAD COFFEE COMPANY, INC., DOWNEY, CA:
4,118,166, PUB. 1-10-2012. INT. CL. 30.

TRIPLE S INCORPORATED, NORWALK, CT:
1,669,738. REN. 2-21-12. INT. CL. 37.

TRITENT INTERNATIONAL CORPORATION, CHICAGO, IL:
2,968,623, CANC. INT. CL. 34.

TRIVANI INTERNATIONAL, LLC, SPRINGVILLE, UT:
4,119,398, MULTIPLE CLASS, INT. CLS. 5 AND 32.

TROLLEY'S, L.L.C., SPRINGFIELD, MO:
2,967,614, CANC. INT. CL. 43.

TRONCOSO, MANUEL, DORCHESTER, MA, AKA LYME LYTE ENTERTAINMENT AND TRONCOSO, SANDI, DORCHESTER, MA, AKA LYME LYTE ENTERTAINMENT AND SMITH, GREG, DORCHESTER, MA, AKA LYME LYTE ENTERTAINMENT:
4,116,663, PUB. 1-10-2012. INT. CL. 41.

TROUBETZKOY, SUSAN M, RIVIERA BEACH, FL:
4,117,202, PUB. 1-10-2012. INT. CL. 16.

TROUBLE, AGNES, PARIS, FRANCE:
2,966,210, CANC. MULTIPLE CLASS, INT. CLS. 3, 14, 18, 24 AND 25.

TROUW INTERNATIONAL B.V., NL-5831 JL BOXMEER, NETHERLANDS:
1,669,648. REN. 2-21-12. INT. CL. 31.

TROVER SOLUTIONS, INC., LOUISVILLE, KY:
2,555,156. REN. 2-22-12. INT. CL. 36.
2,555,157. REN. 2-22-12. INT. CL. 36.

TROY SPORTS RESTAURANT, LLC, TROY, MI, DBA JOE KOOL'S BAR & RESTAURANT:
4,118,176, PUB. 1-10-2012. INT. CL. 43.

TRS QUALITY, INC., FORT WORTH, TX, TANDY CORPORATION, FORT WORTH, TX, DBA RADIO SHACK:
1,676,195. REN. 2-17-12. INT. CL. 42.

TRS RECOVERY SERVICES, INC., HOUSTON, TX:
2,968,679, CANC. INT. CL. 36.

TRUE SETTING SALES & ENG. COMPANY, OSCODA, MI:
2,968,288, CANC. INT. CL. 8.

TRUE SOURCE HONEY LLC, WASHINGTON, DC, AKA TRUE SOURCE:
4,119,766, U.S. CL. A.

TRUECONF PTY LTD, GYMEA, NSW, AUSTRALIA:
4,118,426, PUB. 1-10-2012. INT. CL. 9.

TRUSTEES OF THE UNIVERSITY OF PENNSYLVANIA, PHILADELPHIA, PA:
1,671,044. REN. 2-17-12. INT. CL. 9.

TRUSTEES OF THE UNIVERSITY OF PENNSYLVANIA, THE, PHILADELPHIA, PA:
2,590,932. REN. 2-17-12. MULTIPLE CLASS, INT. CLS. 38 AND 41.
2,590,932, COR. MULTIPLE CLASS, INT. CLS. 38 AND 41.

TRUSTY WARNS, INC., WOOD DALE, IL:
4,117,600, PUB. 1-10-2012. MULTIPLE CLASS, INT. CLS. 7 AND 37.

TRUTEK CORP., HILLSBOROUGH, NJ:
4,119,181, INT. CL. 5.

TSA STORES INC., ENGLEWOOD, CO:
4,117,103, PUB. 1-10-2012. INT. CL. 28.

TSC / TRINITY SOUND COMPANY, ONTARIO, CA:
4,118,157, PUB. 1-10-2012. INT. CL. 41.

TSL ENTERPRISES LIMITED, UNITED KINGDOM:
4,116,760, PUB. 1-10-2012. MULTIPLE CLASS, INT. CLS. 9 AND 28.

TTFN SOFTWARE, INC., GIBSONIA, PA:
2,466,865, CANC. INT. CL. 42.

TUNICA GOLF COURSE LLC., LAS VEGAS, NV:
2,358,670, CANC. INT. CL. 16.

TUONG NGUYEN, WESTMINSTER, CA:
4,118,667, PUB. 1-10-2012. INT. CL. 5.

TUPPER, JAMES, RALEIGH, NC, DBA POST 22:
4,118,543, PUB. 1-10-2012. INT. CL. 25.

TUPPERWARE PRODUCTS S.A., FRIBOURG, SWITZERLAND:
4,118,875, INT. CL. 3.

TURB-O-WEB INTERNATIONAL PTY LIMITED, QUAKERS HILL, NEW SOUTH WALES 2763, AUSTRALIA:
2,967,509, CANC. INT. CL. 42.

TURNAROUND MANAGEMENT ASSOCIATION, CHICAGO, IL:
2,504,475. REN. 2-17-12. INT. CL. 42.

TURNER VISION, INC., BLUEFIELD, WV:
2,730,963, CANC. INT. CL. 38.

TURNER, MINNIE O, SOUTHERN PINES, NC, DBA LUCUBRATE:
4,119,871, INT. CL. 25.

TURNQUIST ELSTINS TECHNOLOGY GROUP LLC, TEMPE, AZ:
4,117,739, PUB. 1-10-2012. MULTIPLE CLASS, INT. CLS. 35 AND 42.

TUTTLE, GENE, CAMARILLO, CA:
4,118,263, PUB. 1-10-2012. INT. CL. 41.

TWANG PARTNERS, LTD, SAN ANTONIO, TX:
2,468,054, CANC. INT. CL. 30.

TWENTIETH CENTURY FOX FILM CORPORATION, LOS ANGELES, CA:
4,119,829, INT. CL. 41.

TWENTY FIRST CENTURY COMMUNICATIONS, INC., COLUMBUS, OH:
4,119,344, INT. CL. 38.

TWIN STAR INTERNATIONAL, INC., DELRAY BEACH, FL:
4,119,403, INT. CL. 11.
4,119,404, INT. CL. 11.

TWODOCS INNOVATIONS, INC., OKLAHOMA CITY, OK, TWODOCS INNOVATIONS, INC., OKLAHOMA CITY, OK:
2,664,635. REN. 2-21-12. INT. CL. 9.

TXI OPERATIONS, LP, DALLAS, TX:
2,527,781. REN. 2-23-12. INT. CL. 19.

TYCO HEALTHCARE GROUP LP, MANSFIELD, MA:
2,525,310. REN. 2-21-12. INT. CL. 5.

TYCO HEALTHCARE GROUP LP, NEW HAVEN, CT:
4,119,742, INT. CL. 10.

TYG S.P.A., MILANO, ITALY:
2,526,446. REN. 2-22-12. INT. CL. 12.

TYLER JAMES BRYANT, KINGSTON, NY, DBA VELOUS:
4,117,703, PUB. 1-10-2012. INT. CL. 41.

TYLER MANNING, LOUISVILLE, KY:
4,119,165, INT. CL. 14.

TYROLIT - SCHLEIFMITTELWERKE SWAROVSKI K.G., AUSTRIA:
4,116,862, PUB. 1-10-2012. INT. CL. 9.

U GOT STINK FRANCHISING, LLC, PORTLAND, OR:
4,118,073, PUB. 1-10-2012. INT. CL. 40.

U.S. AIRWAYS, INC., TEMPE, AZ:
2,967,685, CANC. INT. CL. 39.

U.S. DEPARTMENT OF HEALTH AND HUMAN SERVICES, BETHESDA, MD:
4,117,351, PUB. 1-10-2012. INT. CL. 35.
4,117,381, PUB. 1-10-2012. INT. CL. 42.

U.S. FARMERS & RANCHERS ALLIANCE, INC., CHESTERFIELD, MO:
4,119,641, INT. CL. 35.

U.S. INVESTMENT CORP., WAYNE, PA:
4,118,046, PUB. 1-10-2012. INT. CL. 36.

U-BLOX AG, CH-8800 THALWIL, SWITZERLAND:
4,116,853, PUB. 1-10-2012. MULTIPLE CLASS, INT. CLS. 9, 38 AND 42.

U-MATCH, LLC, PLANTATION, FL, DBA ROOMBUG:
4,119,677, INT. CL. 42.

U-NICA INTERNATIONAL AG, MALANS, SWITZERLAND:
4,116,895, PUB. 1-10-2012. MULTIPLE CLASS, INT. CLS. 9, 35 AND 45.

U-SING, PASADENA, CA:
4,118,683, PUB. 1-10-2012. INT. CL. 9.

UGALDE, ANDREA, CORONA, CA:
4,119,869, INT. CL. 25.

UHS OF DELAWARE, INC., KING OF PRUSSIA, PA:
2,538,884. REN. 2-23-12. INT. CL. 42.

UI HOLDING CO., CONKLIN, NY:
2,519,819. REN. 2-21-12. INT. CL. 7.

- UM TECHNICAL CORPORATION, SUGAR LAND, TX:
4,118,091, PUB. 1-10-2012. INT. CL. 35.
- UMG ABS, LTD., CHUO-KU, TOKYO, JAPAN:
2,531,318. REN. 2-22-12. INT. CL. 1.
- UNDERGROUND GAMES, INC., REDONDO BEACH, CA:
2,525,632. REN. 2-17-12. INT. CL. 28.
- UNI-PRESIDENT ENTERPRISES CORP., TAINAN HSIEN, TAIWAN:
2,663,537. REN. 2-21-12. INT. CL. 30.
- UNIBOARD CANADA INC., LAVAL, QUEBEC, CANADA:
4,116,950, PUB. 1-10-2012. MULTIPLE CLASS, INT. CLS. 19 AND 20.
- UNICOGNAC S.A., FRANCE:
2,967,221.
- UNILEVER PLC, MERSEYSIDE, UNITED KINGDOM:
2,967,664, CANC. INT. CL. 3.
- UNILEVER SUPPLY CHAIN, INC., CLINTON, CT:
2,968,587, CANC. INT. CL. 14.
- UNILIN FLOORING NC, LLC, CHATSWORTH, GA:
2,968,171, CANC. INT. CL. 19.
- UNION HARBOUR LIMITED, HONG KONG, CHINA:
4,116,666, PUB. 8-26-2008. MULTIPLE CLASS, INT. CLS. 18 AND 25.
4,116,667, PUB. 1-10-2012. MULTIPLE CLASS, INT. CLS. 18 AND 25.
- UNION SQUARE BUSINESS IMPROVEMENT DISTRICT, INC., SAN FRANCISCO, CA:
4,117,826, PUB. 1-10-2012. INT. CL. 35.
- UNION SQUARE EYE CARE LLC, NEW YORK, NY:
4,117,235, PUB. 1-10-2012. INT. CL. 44.
- UNIQUE SQUARED INC., ATLANTA, GA:
4,117,789, PUB. 1-10-2012. INT. CL. 35.
- UNIRE REAL ESTATE GROUP, INC., BREA, CA:
2,968,813, CANC. INT. CL. 36.
- UNISYS CORPORATION, BLUE BELL, PA:
4,117,355, PUB. 1-10-2012. INT. CL. 9.
- UNITARIAN UNIVERSALIST ASSOCIATION CORPORATION, BOSTON, MA, DBA BEACON PRESS:
4,117,393, PUB. 1-10-2012. INT. CL. 16.
- UNITED COMMUNICATIONS SYSTEMS, INC., CHICAGO, IL, DBA CALL ONE:
4,116,607, PUB. 1-10-2012. MULTIPLE CLASS, INT. CLS. 35 AND 39.
- UNITED ELECTRIC SUPPLY COMPANY, INC., NEW CASTLE, DE:
1,669,919. REN. 2-21-12. INT. CL. 42.
1,671,487. REN. 2-21-12. INT. CL. 42.
- UNITED FEATURE SYNDICATE, INC., NEW YORK, NY:
555,846. REN. 2-22-12. U.S. CL. 38 (INT. CL. 16).
- UNITED NATURAL FOODS, INC., PROVIDENCE, RI:
4,119,519, INT. CL. 4.
- UNITED OVERSEAS BANK S.A., 1211 GENEVA, SWITZERLAND:
1,071,952, CANC. INT. CL. 36.
- UNITED PHOSPHORUS, INC., TRENTON, NJ:
2,968,223, CANC. INT. CL. 5.
- UNITED SERVICES AUTOMOBILE ASSOCIATION, SAN ANTONIO, TX:
4,119,552, INT. CL. 36.
- UNITED STATES DEPARTMENT OF ENERGY, WASHINGTON, DC:
4,117,096, PUB. 1-10-2012. MULTIPLE CLASS, INT. CLS. 35 AND 36.
- UNITED STATES DOG AGILITY ASSOCIATION, INC., RICHARDSON, TX:
2,523,995. REN. 2-21-12. INT. CL. 41.
- UNITED STATES PLAYING CARD COMPANY, THE, ERLANGER, KY:
151,272. REN. 2-17-12. U.S. CL. 22 (INT. CL. 16).
- UNITED STATES PLAYING CARD COMPANY, THE, CINCINNATI, OH, UNITED STATES PLAYING CARD COMPANY, THE, CINCINNATI, OH:
726,940. REN. 2-22-12. U.S. CL. 22 (INT. CL. 28).
- UNITEDHEALTH GROUP INCORPORATED, MINNETONKA, MN:
2,968,329, CANC. INT. CL. 36.
4,118,786, MULTIPLE CLASS, INT. CLS. 35 AND 36.
4,118,787, MULTIPLE CLASS, INT. CLS. 35 AND 36.
- UNITEX INTERNATIONAL, INC., SUWANEE, GA:
4,119,280, MULTIPLE CLASS, INT. CLS. 22 AND 24.
- UNITHER NUTRICEUTICALS, INC., SILVER SPRING, MD:
2,968,396, CANC. INT. CL. 5.
- UNIVERISTY OF MIAMI, CORAL GABLES, FL:
2,661,706. REN. 2-22-12. INT. CL. 35.
- UNIVERSAL ACCESS, LLC, SCOTTSDALE, AZ:
2,467,115, CANC. INT. CL. 38.
- UNIVERSAL AIR TRAVEL PLAN, INC., WASHINGTON, DC:
4,117,659, PUB. 1-10-2012. INT. CL. 36.
- UNIVERSAL CITY STUDIOS LLLP, UNIVERSAL CITY, CA:
2,468,120, CANC. INT. CL. 39.
- UNIVERSAL HOSPITAL SERVICES, INC., EDINA, MN:
1,185,243. REN. 2-21-12. INT. CL. 42.
- UNIVERSAL LIGHTING TECHNOLOGIES, INC., NASHVILLE, TN:
4,118,774, INT. CL. 9.
- UNIVERSAL TRADING GROUP, LLC, LINCOLNWOOD, IL:
2,967,714, CANC. INT. CL. 3.
- UNIVERSITY MEDICAL PHARMACEUTICALS CORP., IRVINE, CA:
4,119,401, INT. CL. 5.
- UNIVERSITY OF CHICAGO, THE, CHICAGO, IL:
4,118,877, INT. CL. 16.
4,118,878, INT. CL. 41.
- UNIVERSITY OF NORTH CAROLINA AT CHAPEL HILL, CHAPEL HILL, NC:
3,989,407, COR. INT. CL. 41.
3,989,408, COR. INT. CL. 41.
3,994,836, COR. INT. CL. 41.
- UNIVERSITY OF NORTH TEXAS, DENTON, TX:
4,118,698, PUB. 1-10-2012. INT. CL. 24.
- UNIVISION RADIO, INC., DALLAS, TX:
2,579,796. REN. 2-22-12. MULTIPLE CLASS, INT. CLS. 35, 38 AND 41.
- UNLIMITED JEANS CO, INC., NEW YORK, NY:
4,117,720, PUB. 1-10-2012. INT. CL. 35.
- UNOFFICIAL MARTIN GUITAR FORUM, A NEW JERSEY NONPROFIT CORPORATION, LEBANON, NJ:
4,118,583, PUB. 1-10-2012. INT. CL. 38.
- UPLAND DESIGN, LTD., PLAINFIELD, IL:
4,118,079, PUB. 1-10-2012. INT. CL. 42.
- URBAN SAMURAI, SANTA MONICA, CA:
2,968,354, CANC. INT. CL. 25.
- URBANA SOFTWARE, INC., SAN FRANCISCO, CA:
2,967,625, CANC. INT. CL. 9.
- URBANSKI, MICHAEL C., FORT WORTH, TX:
4,117,950, PUB. 1-10-2012. INT. CL. 35.
- UREFER, INC., ANN ARBOR, MI, DBA AMPLIFINITY, INC.:
4,119,218, INT. CL. 35.
- US AIRWAYS, INC., TEMPE, AZ:
4,118,431, PUB. 1-10-2012. INT. CL. 39.
4,118,945, INT. CL. 43.
- US BUS CHARTER AND LIMO, INC., STATEN ISLAND, NY:
4,021,809, CANC. INT. CL. 39.
- US DEPARTMENT OF ENERGY, WASHINGTON, DC:
2,467,989, CANC. INT. CL. 41.
- US ROASTERIE, INC., DES MOINES, IA:
4,118,970, INT. CL. 30.
- USA ENTERPRISE, BRICK, NJ:
4,118,329, PUB. 1-10-2012. INT. CL. 20.
- USA MOBILE DRUG TESTING, LLC, TAMPA, FL:
4,119,838, INT. CL. 44.
- USA-FORECLOSURE.COM, LLC, BELLEVUE, WA:
4,117,213, PUB. 1-10-2012. INT. CL. 36.
- USAA LLC, LOS GATOS, CA, DBA INTERNATIONAL INSTITUTE OF EVENT MANAGEMENT:
4,119,827, INT. CL. 41.
- USABLE MUTUAL INSURANCE COMPANY, LITTLE ROCK, AR:
4,119,620, MULTIPLE CLASS, INT. CLS. 41 AND 44.
- USO OF NORTH CAROLINA, INC, RALEIGH, NC:
4,119,048, INT. CL. 41.
- USP LABS, LLC, DALLAS, TX:
4,118,962, INT. CL. 5.

V.O.F. "LUMIÈRE", LOPIK, NETHERLANDS:
4,116,804, PUB. 1-10-2012. INT. CL. 11.

VACOM VAKUUM KOMONENTEN & MESSTECHNIK GMBH, FED REP GERMANY:
4,054,508, COR. MULTIPLE CLASS, INT. CLS. 7, 9 AND 42.

VAGABOND "SPEECH" PRODUCTIONS, INC., FAYETTEVILLE, GA:
4,118,584, PUB. 1-10-2012. INT. CL. 9.

VAGHEGGI S.P.A., NANTO (VICENZA), ITALY:
2,965,652, CANC. INT. CL. 3.

VAGOS INTERNATIONAL MOTORCYCLE CLUB, DIAMOND BAR, CA:
4,116,905, PUB. 1-10-2012. MULTIPLE CLASS, INT. CLS. 14, 25, 26 AND 41.

VAHLE, PAMELA, WILLIAMSPORT, MD:
4,117,861, PUB. 1-10-2012. INT. CL. 3.

VAL-MATIC VALVE AND MANUFACTURING CORPORATION, ELMHURST, IL:
4,118,873, MULTIPLE CLASS, INT. CLS. 7 AND 9.

VALAGRO S.P.A., PIAZZANO DI ATESSA(CH), ITALY:
4,119,345, INT. CL. 1.

VALEANT INTERNATIONAL (BARBADOS) SRL, CHRIST CHURCH, BARBADOS:
4,116,673, PUB. 1-10-2012. INT. CL. 5.

VALENTINO S.P.A., MILANO, ITALY:
1,191,740, REN. 2-22-12. INT. CL. 25.

VALIANT ENTERTAINMENT, INC., ROAD TOWN, BR. VIRGIN ISLANDS:
4,118,777, INT. CL. 16.

VALIDUS VENTURES, LLC, URBANDALE, IA:
2,968,450, CANC. MULTIPLE CLASS, INT. CLS. 41 AND 44.

VALLS HOLDINGS, INC., MIAMI, FL:
4,118,935, INT. CL. 11.

VAN DER VEER, KAREN, FLAGSTAFF, AZ:
4,119,368, INT. CL. 25.

VAN DORN DEMAG CORPORATION, STRONGSVILLE, OH:
2,968,058, CANC. INT. CL. 7.

VANACORE MUSIC PUBLISHING, LLC, SANTA CLARITA, CA:
4,119,789, INT. CL. 41.

VANCO OVERSEAS ENERGY LIMITED, LIMASSOL, CYPRUS:
4,117,611, PUB. 1-10-2012. INT. CL. 42.

VANS, INC., CYPRESS, CA:
4,118,479, PUB. 1-10-2012. MULTIPLE CLASS, INT. CLS. 25 AND 41.

VANTAGE AGORA INC., MENTOR, OH:
4,117,354, PUB. 1-10-2012. MULTIPLE CLASS, INT. CLS. 35, 36 AND 45.

VANTIV, LLC, CINCINNATI, OH:
4,117,485, PUB. 1-10-2012. INT. CL. 36.

VARA FOOD & DRINK CO LTD, BANGKOK 10700, THAILAND, T.A.S. TRADING CO., LTD., BANGPLUD, BANGKOK 10700, THAILAND:
1,716,081, REN. 2-21-12. INT. CL. 29.

VARA KAMIN'S IMPRESSIONS OF LIGHT, INC., MINNEAPOLIS, MN:
2,521,838, REN. 2-22-12. INT. CL. 11.

VECTOR CAPITAL CORPORATION, SAN FRANCISCO, CA:
2,645,126, REN. 2-22-12. INT. CL. 36.

VEDAN ENTERPRISE CORP., SHALU, TAICHUNG, TAIWAN:
1,691,795, REN. 2-23-12. INT. CL. 30.

VEDCO, INC., SAINT JOSEPH, MO:
1,745,476, REN. 2-21-12. INT. CL. 5.

VELOX PRODUCTS, LLC, WESTON, FL:
4,119,628, INT. CL. 5.

VELVET YOGURT, INC., FOOTHILL RANCH, CA:
4,116,935, PUB. 1-10-2012. INT. CL. 35.

VENDRE STORE LLC, ATLANTA, GA:
4,118,498, PUB. 1-10-2012. INT. CL. 35.

VENETIAN MEAT & SALAMI CO. LTD, HAMILTON, ONTARIO, CANADA:
2,573,065, REN. 2-19-12. INT. CL. 29.

VENTE, INC., OMAHA, NE:
2,968,195, CANC. INT. CL. 35.

VERARI SYSTEMS, INC., SAN DIEGO, CA:
2,967,622, CANC. INT. CL. 9.

VERIDIAN STRATEGIES, LLC, HIGHLAND, UT:
4,116,631, PUB. 1-10-2012. INT. CL. 42.

VERMILLION CRUSH, LLC, SAN FRANCISCO, CA:
4,118,825, INT. CL. 41.

VERMONT PHOTOINKJET, LLC, TOPSHAM, VT:
4,119,364, INT. CL. 2.

VERSAR, INC., SPRINGFIELD, VA:
1,184,290, REN. 2-22-12. MULTIPLE CLASS, INT. CLS. 37, 41 AND 42.
1,184,290, CANC. MULTIPLE CLASS, INT. CLS. 1, 6, 9, 17 AND 40.

VERTELLUS SPECIALTIES INC., INDIANAPOLIS, IN:
4,117,911, PUB. 1-10-2012. INT. CL. 1.

VERVANO, LLC, AUSTIN, TX:
4,119,457, INT. CL. 20.

VESTAS WIND SYSTEMS A/S, DK-8940 RANDERS, DENMARK:
4,116,682, PUB. 1-10-2012. MULTIPLE CLASS, INT. CLS. 7, 9 AND 37.

VETGENIX, LLC, WELLINGTON, FL:
4,117,643, PUB. 1-10-2012. INT. CL. 5.
4,117,644, PUB. 1-10-2012. INT. CL. 5.

VETRURIA S.R.L., 50056 MONTELUPO FIORENTINO FI, ITALY:
2,967,317, CANC. MULTIPLE CLASS, INT. CLS. 21 AND 35.

VIA METROPOLITAN TRANSIT AUTHORITY AND VIA ADVANCED TRANSPORTATION DISTRICT, SAN ANTONIO, TX:
4,116,896, PUB. 1-10-2012. INT. CL. 39.

VIACOM INTERNATIONAL INC., NEW YORK, NY:
2,968,038, CANC. INT. CL. 41.

VIACYTE, INC., SAN DIEGO, CA:
4,119,083, INT. CL. 10.

VIASYS HOLDINGS INC., CONSHOHOCKEN, PA:
2,466,844, CANC. INT. CL. 10.

VIBRANT HEALTH PRODUCTS INC., ABBOTSFORD, BC, CANADA, DBA SILVER HILLS BAKERY:
4,116,948, PUB. 1-10-2012. INT. CL. 30.

VICENTIN S.A.I.C, SANTA FE, ARGENTINA:
4,119,066, INT. CL. 33.

VICTOR COMPANY OF JAPAN, LIMITED, YOKOHAMA-CITY, JAPAN:
2,966,158, CANC. INT. CL. 9.

VICTOR EQUIPMENT COMPANY, CHESTERFIELD, MO, ARCAIR COMPANY, THE, LANCASTER, OH:
1,189,814, REN. 2-22-12. INT. CL. 9.
1,190,507, REN. 2-21-12. INT. CL. 9.

VICTOR PACKING, INC., MADERA, CA:
4,118,106, PUB. 1-10-2012. INT. CL. 29.

VICTORIA'S SECRET STORES BRAND MANAGEMENT, INC., REYNOLDSBURG, OH:
4,118,910, MULTIPLE CLASS, INT. CLS. 3 AND 25.

VICTORSON, STEVEN EARL, BOXBOROUGH, MA, DBA SWYMFIT:
4,117,616, PUB. 1-10-2012. INT. CL. 41.

VICTORY BREWING COMPANY, DOWNINGTOWN, PA:
4,118,633, PUB. 1-10-2012. INT. CL. 32.

VIDEO PROFESSOR, INC., LAKEWOOD, CO:
2,967,832, CANC. INT. CL. 16.

VILLALOBOS, LILIANA C., LIMA 34, PERU:
4,118,097, PUB. 1-10-2012. INT. CL. 25.

VINCI CO., LLC, HENRICO, VA:
4,118,113, PUB. 1-10-2012. INT. CL. 28.

VIP FUNDRAISERS, INC., CHARLOTTE, NC:
4,119,881, INT. CL. 36.

VIRBAC, FRANCE:
4,116,746, PUB. 1-10-2012. INT. CL. 5.
4,116,747, PUB. 1-10-2012. INT. CL. 5.
4,116,748, PUB. 1-10-2012. INT. CL. 5.

VIRGINIA LEGENDS ELITE SOFTBALL ORGANIZATION, LLC, CHESAPEAKE, VA:
4,119,390, INT. CL. 41.

- VIRTUA HEALTH, INC., MARLTON, NJ:
4,117,348, PUB. 1-10-2012. INT. CL. 44.
- VIRTUAL CONTEXT INC., TORONTO, CANADA:
4,117,144, PUB. 1-10-2012. INT. CL. 9.
- VIRTUAL MEDIA LLC, LAKE TAHOE, NV:
4,118,510, PUB. 1-10-2012. INT. CL. 35.
- VISI INCORPORATED, EDEN PRAIRIE, MN:
4,118,971, MULTIPLE CLASS, INT. CLS. 38, 39 AND 42.
4,118,994, MULTIPLE CLASS, INT. CLS. 38, 39 AND 42.
- VISIBLE MEASURES CORP., BOSTON, MA:
4,119,780, INT. CL. 35.
4,119,781, INT. CL. 35.
- VISIO SERVICES, LTD., STAEFA, SWITZERLAND:
4,117,546, PUB. 1-10-2012. INT. CL. 9.
- VISION WHEEL, INC., DECATUR, AL:
2,645,171, REN. 2-21-12. INT. CL. 12.
2,651,052, REN. 2-20-12. INT. CL. 16.
- VISIONEDGE MARKETING, INC., AUSTIN, TX:
4,117,293, PUB. 1-10-2012. INT. CL. 42.
4,117,294, PUB. 1-10-2012. INT. CL. 42.
- VISIONMAX, INC., CITY OF INDUSTRY, CA:
4,118,120, PUB. 1-10-2012. INT. CL. 26.
- VISIONS GLASS INC., BYRON CENTER, MI, DBA VISIONS AUTO GLASS:
2,514,834, REN. 2-21-12. INT. CL. 37.
- VISTA, INC., REDMOND, WA:
2,467,626, CANC. INT. CL. 42.
- VISTO CORPORATION, REDWOOD CITY, CA:
2,967,387, CANC. INT. CL. 38.
- VISUALMED CLINICAL SYSTEMS INC., MONTREAL, PROVINCE OF QUEBEC, H2V 2K3, CANADA:
2,965,433, CANC. MULTIPLE CLASS, INT. CLS. 9, 10 AND 20.
- VITA CRAFT CORPORATION, SHAWNEE, KS:
2,967,835, CANC. INT. CL. 21.
- VITAL IDEA INC, CHATSWORTH, CA:
2,891,440, CANC. INT. CL. 9.
- VITAMIN RESEARCH PRODUCTS, LLC, CARSON CITY, NV:
2,547,330, REN. 2-19-12. INT. CL. 5.
- VITAMONT, F-47150 MONFLANQUIN, FRANCE:
2,967,227.
- VITAPATH GENETICS, INC., FOSTER CITY, CA:
4,119,213, INT. CL. 44.
- VITATECH INTERNATIONAL, INC., TUSTIN, CA:
2,935,552, COR. INT. CL. 40.
- VIZIBILITY INC., NEW YORK, NY:
4,118,348, PUB. 1-10-2012. INT. CL. 42.
- VIZON TEKSTIL ITHALAT IHRACAT VE MÜMESSILIK LIMITED SIRKETI, TURKEY:
4,116,827, PUB. 1-10-2012. MULTIPLE CLASS, INT. CLS. 25 AND 35.
- VIZUALL, INC., HOLLYWOOD, FL, AKA SCHEDUALL:
4,118,955, INT. CL. 9.
- VI360.COM, INC., ESTERO, FL:
2,967,789, CANC. INT. CL. 35.
- VOCO GMBH, FED REP GERMANY:
4,116,852, PUB. 1-10-2012. MULTIPLE CLASS, INT. CLS. 5 AND 10.
- VOLCOM, INC., COSTA MESA, CA:
2,534,210, REN. 2-22-12. INT. CL. 25.
- VOLLEYFROG, LLC, FORT MYERS, FL:
4,119,127, INT. CL. 41.
4,119,134, INT. CL. 41.
- VOLTATA CONSULTING, LLC, CARSON CITY, NV:
2,925,179, CANC. INT. CL. 36.
- VONLAY, LLC, MADISON, WI:
4,118,343, PUB. 1-10-2012. INT. CL. 35.
- VOSGES IP, LLC, CHICAGO, IL:
4,117,661, PUB. 1-10-2012. INT. CL. 30.
- VOTORANTIM PARTICIPACOES S/A, SAO PAULO, SP, BRAZIL:
2,967,987, CANC. INT. CL. 19.
- VOX MEDIA, INC., WASHINGTON, DC:
4,119,604, MULTIPLE CLASS, INT. CLS. 38 AND 41.
- VOXIFY, INC., ALAMEDA, CA:
4,117,444, PUB. 1-10-2012. MULTIPLE CLASS, INT. CLS. 9 AND 42.
- VOXOFON LLC, HOUSTON, TX:
4,117,551, PUB. 1-10-2012. MULTIPLE CLASS, INT. CLS. 9 AND 38.
- VOYAGES NORTH AMERICA, INC., NEW YORK, NY:
4,118,899, INT. CL. 38.
- VOYZZE COMMUNICATIONS INC, FREMONT, CA:
4,119,107, INT. CL. 38.
- VPN NETSERVICES, LLC., LYNN HAVEN, FL, DBA NET-SERVICES, LLC.:
4,118,660, PUB. 1-10-2012. INT. CL. 38.
- VYAN, LLC, CLARKSTON, MI:
4,118,458, PUB. 1-10-2012. MULTIPLE CLASS, INT. CLS. 18, 25 AND 35.
- VYENIELO, CHRIS, SAN RAFAEL, CA:
4,119,582, INT. CL. 33.
- W. E. BASSETT COMPANY, THE, SHELTON, CT:
1,684,122, REN. 2-22-12. INT. CL. 8.
- W. L. GORE & ASSOCIATES, INC., NEWARK, DE:
2,525,502, REN. 2-21-12. INT. CL. 9.
- W. R. GRACE & CO.-CONN., COLUMBIA, MD:
4,118,831, INT. CL. 1.
- W.M. BARR & COMPANY, INC., MEMPHIS, TN:
2,968,246, CANC. INT. CL. 3.
- WAHOUIÉ, JAMEELAH ZADDYS, 1094 KN AMSTERDAM, NETHERLANDS:
4,117,141, PUB. 1-10-2012. MULTIPLE CLASS, INT. CLS. 9, 16, 28 AND 41.
- WAKE INNOVATION, LLC, RALEIGH, NC:
4,117,894, PUB. 1-10-2012. INT. CL. 5.
- WAKEFERN FOOD CORP., KEASBEY, NJ:
2,967,680, CANC. INT. CL. 32.
4,117,071, PUB. 1-10-2012. INT. CL. 42.
- WAL-MART STORES, INC., BENTONVILLE, AR:
2,967,729, CANC. INT. CL. 32.
2,967,806, CANC. INT. CL. 35.
- WALCOFF, GREGORY D., VAN NUYS, CA AND WALCOFF, DARLA K., VAN NUYS, CA AND WALCOFF, GEORGE M., HOUSTON, TX:
2,968,202, CANC. INT. CL. 25.
- WALDRON, MARCIE BECKER, SONOMA, CA:
4,119,539, INT. CL. 14.
- WALGREEN CO., DEERFIELD, IL:
2,967,988, CANC. INT. CL. 26.
4,117,965, PUB. 1-10-2012. INT. CL. 5.
- WALKER FOODS, INC., LOS ANGELES, CA, DBA LA FLOR DEL SUR EMPACADORES:
1,736,864, REN. 2-21-12. INT. CL. 30.
- WALKER, LONNIE, HOUSTON, TX:
4,117,963, PUB. 1-10-2012. INT. CL. 30.
- WALKER, RICHARD A., ALPHARETTA, GA:
4,119,541, INT. CL. 35.
- WALLACE O'FARRELL MARKETING, INC., PUYALLUP, WA:
1,219,615, REN. 2-22-12. INT. CL. 3.
- WALLACE, DONNA MARIE BAYLES, BIGGS, CA, DBA BAYLES RANCH:
2,466,948, CANC. INT. CL. 3.
- WALLMONKEYS.COM, OLNEY, MD:
4,117,550, PUB. 1-10-2012. INT. CL. 16.
- WALONG MARKETING, INC., BUENA PARK, CA:
2,539,150, REN. 2-21-12. INT. CL. 35.
- WANG HUANAN, GUANGDONG PROVINCE, CHINA:
4,118,383, PUB. 1-10-2012. INT. CL. 5.
- WARD STEEL SERVICE COMPANY, DAYTON, OH:
1,197,696, REN. 2-22-12. INT. CL. 6.
- WARD, DON, LOS ANGELES, CA:
4,117,749, PUB. 1-10-2012. INT. CL. 25.
- WARNACO U.S., INC., NEW YORK, NY, WARNACO INC., NEW YORK, NY:
1,669,540, REN. 2-21-12. INT. CL. 25.
- WARREN AND MUNGRA LLC, SALEM, OR, DBA FROYO NATION AT BROADWAY COMMONS:
4,118,047, PUB. 1-10-2012. INT. CL. 30.
- WARSAW ORTHOPEDIC, INC., WARSAW, IN:
2,968,661, CANC. INT. CL. 10.

WASHINGTON TEAM TENNIS LLC, WASHINGTON, DC:
 4,118,846, INT. CL. 25.
 4,118,847, INT. CL. 26.
 4,118,848, INT. CL. 25.
 4,118,849, INT. CL. 26.

WASHINGTON WINE COMMISSION, SEATTLE, WA:
 2,923,024, CANC. MULTIPLE CLASS, INT. CLS. 35 AND 41.

WASNICK, STEVE, ST. ANTHONY, MN:
 4,119,452, INT. CL. 35.
 4,119,453, INT. CL. 35.

WATER ENVIRONMENT FEDERATION, ALEXANDRIA, VA:
 2,468,508, CANC. INT. CL. 16.

WATER POINTE REALTY GROUP, LLC, STUART, FL:
 4,118,237, PUB. 1-10-2012. INT. CL. 36.
 4,118,307, PUB. 1-10-2012. INT. CL. 36.

WATERFORD SCHOOL, LLC, SANDY, UT:
 4,118,349, PUB. 1-10-2012. INT. CL. 41.
 4,118,350, PUB. 1-10-2012. INT. CL. 41.
 4,118,351, PUB. 1-10-2012. INT. CL. 41.

WATERSENSE, INC., NEW HAVEN, KY:
 2,640,321. REN. 2-17-12. MULTIPLE CLASS, INT. CLS. 1, 11 AND 40.

WATKINS MANUFACTURING CORPORATION, VISTA, CA:
 2,468,202, CANC. INT. CL. 9.

WATSON STANDARD COMPANY, HARWICK, PA:
 4,117,423, PUB. 10-4-2011. MULTIPLE CLASS, INT. CLS. 1, 2 AND 4.

WATSON, BRUCE, VANCOUVER, B.C., CANADA:
 2,523,896. REN. 2-22-12. INT. CL. 9.

WATSON, JENNIFER L, RICHMOND, VA AND BLESS, BARRY R, RICHMOND, VA:
 4,116,627, PUB. 1-10-2012. INT. CL. 36.

WATTS, CRYSTAL R., GOOSE CREEK, SC:
 4,116,882, PUB. 1-10-2012. INT. CL. 41.

WAX SPECIALISTS, LLC, MANCHESTER, NH:
 4,117,573, PUB. 1-10-2012. INT. CL. 44.

WAY, ALEXIS, ST. MARYS, GA, DBA WWW.BABYSPTY.COM:
 4,117,345, PUB. 1-10-2012. INT. CL. 25.

WBI INVESTMENTS, INC., LITTLE SILVER, NJ:
 4,118,496, PUB. 1-10-2012. INT. CL. 36.

WEATHER CENTRAL, LP, MADISON, WI:
 2,525,133. REN. 2-21-12. INT. CL. 9.
 2,553,075. REN. 2-20-12. INT. CL. 9.

WEAVER POPCORN COMPANY INC, NOBLESVILLE, IN:
 4,119,476, INT. CL. 30.

WEBB, CHRISOLA, WASHINGTON, DC AND YANCEY, TAWAN, WASHINGTON, DC:
 4,117,289, PUB. 1-10-2012. INT. CL. 35.

WEBGEN SYSTEMS, INC., CAMBRIDGE, MA:
 2,968,026, CANC. INT. CL. 9.

WEBGOPHERS, INC., CUMMING, GA:
 4,118,185, PUB. 1-10-2012. INT. CL. 20.

WEDDING TICKET REGISTRY, SAN FRANCISCO, CA:
 4,118,071, PUB. 1-10-2012. INT. CL. 35.

WEIDER HEALTH AND FITNESS, WOODLAND HILLS, CA:
 4,118,750, INT. CL. 25.

WEILER ENGINEERING, INC., ELGIN, IL:
 2,623,385. REN. 2-22-12. INT. CL. 7.

WEINBERGER, AUDREY E., BROOKLYN, NY AND EISEN-
 PRESS, SHERRI L., NEW YORK, NY:
 4,117,437, PUB. 1-10-2012. INT. CL. 25.

WEITZMAN MANAGEMENT CORPORATION, DALLAS, TX:
 4,117,064, PUB. 1-10-2012. MULTIPLE CLASS, INT. CLS. 36 AND 37.

WEKA FACHMEDIEN GMBH, 85549 HAAR, FED REP GERMANY AND NURNBERGMESSE GMBH, 90471 NURNBERG, FED REP GERMANY:
 2,801,914, AM. MULTIPLE CLASS, INT. CLS. 9, 16 AND 35.

WELDON ENTERPRISES, INC., ORANGE PARK, FL, DBA ALL AMERICAN CARBURETORS:
 4,118,515, PUB. 1-10-2012. INT. CL. 37.

WELLS-GARDNER ELECTRONICS CORPORATION, MCCOOK, IL:
 4,117,045, PUB. 1-10-2012. INT. CL. 9.

WELMEDIX LLC, PRINCETON, NJ:
 3,437,359, CANC. INT. CL. 5.

WENGER CORPORATION, OWATONNA, MN:
 4,119,222, INT. CL. 6.

WESSELS, JEREMIAH RAY, LINCOLN, NE, AKA J.R. WESSELS:
 4,118,412, PUB. 1-10-2012. INT. CL. 42.

WEST FORCE USA INC., NEW YORK, NY:
 4,117,554, PUB. 1-10-2012. INT. CL. 14.

WESTATES TRUCK EQUIPMENT, CORP., WOODLAND, CA:
 2,467,331, CANC. MULTIPLE CLASS, INT. CLS. 9, 12 AND 37.

WESTECH INVESTMENT ADVISORS LLC, SAN JOSE, CA:
 4,118,354, PUB. 1-10-2012. INT. CL. 36.

WESTERFIELD, JAMES, FREEBURG, IL:
 2,967,722, CANC. INT. CL. 31.

WESTERN ENERGY INSTITUTE, PORTLAND, OR:
 4,117,099, PUB. 1-10-2012. MULTIPLE CLASS, INT. CLS. 35, 38, 40 AND 41.
 4,117,100, PUB. 1-10-2012. INT. CL. 41.

WESTERN METAL SUPPLY CO., SAN DIEGO, CA:
 2,967,429, CANC. INT. CL. 32.

WESTERN OUTDOOR PUBLICATIONS, INC., SAN CLEM-
 ENTE, CA:
 2,466,947, CANC. INT. CL. 16.

WESTERN SKY FINANCIAL, LLC, TIMBER LAKE, SD:
 4,118,356, PUB. 1-10-2012. INT. CL. 36.

WESTLAKE LONGVIEW CORPORATION, HOUSTON, TX:
 2,460,082. REN. 2-21-12. INT. CL. 1.

WESTLAND PERPETUAL TRUST, INC., WESTBOROUGH, MA:
 2,467,332, CANC. INT. CL. 42.

WESTMORELAND DAVIS MEMORIAL FOUNDATION, INCORPORATED, THE, LEESBURG, VA:
 934,651. REN. 2-22-12. U.S. CL. 107 (INT. CL. 41).

WESTPOINT STEVENS INC. I, LAS VEGAS, NV TO WP IP, LLC, NEW YORK, NY:
 2,483,486, CANC. INT. CL. 27.

WEXLER, LEE, NEW YORK, NY:
 4,119,674, INT. CL. 41.

WEYERHAEUSER EMPLOYEES' CREDIT UNION, LONG-
 VIEW, WA:
 2,967,836, CANC. INT. CL. 36.

WHEELER MANUFACTURING CO., INC., LEMMON, SD:
 2,519,797. REN. 2-21-12. INT. CL. 14.

WHIRLPOOL PROPERTIES, INC., ST. JOSEPH, MI:
 4,119,239, INT. CL. 11.

WHISPER HILL, LLC, HARTLAND FOUR CORNERS, VT:
 4,118,623, PUB. 1-10-2012. INT. CL. 3.

WHITE HEN PANTRY, INC., OAK BROOK, IL:
 934,647. REN. 2-22-12. U.S. CL. 101 (INT. CL. 42).

WHITE HEN PANTRY, INC., OAK BROOK, IL, JEWEL COMPANIES, INC., CHICAGO, IL:
 934,648. REN. 2-22-12. U.S. CL. 101 (INT. CL. 42).

WHITE ROSE INC., ROBESONIA, PA:
 549,127. REN. 2-17-12. U.S. CL. 46 (INT. CLS. 1, 5, 29, 30, 31 AND 32).

WHITE, STEPHEN, PORT WASHINGTON, NY:
 4,119,088, INT. CL. 41.

WHITELIGHT DESIGN, INC, LAWRENCEVILLE, GA:
 2,524,808. REN. 2-21-12. INT. CL. 42.

WHO IS YOUR INSURANCE, INC., WESTON, FL:
 4,118,433, PUB. 1-10-2012. INT. CL. 42.

WHOLE SPACE INDUSTRIES LTD., TAIPEI, TAIWAN:
 4,118,082, PUB. 1-10-2012. INT. CL. 19.

WI-FI ALLIANCE, AUSTIN, TX:
 2,523,241. REN. 2-21-12. U.S. CL. A.
 2,525,795. REN. 2-21-12. U.S. CL. A.

WICHELT IMPORTS, INC., STODDARD, WI:
 2,629,402. REN. 2-21-12. INT. CL. 24.

WICK COMMUNICATIONS CO., SIERRA VISTA, AZ:
 4,117,496, PUB. 1-10-2012. MULTIPLE CLASS, INT. CLS. 16, 35 AND 41.

- WIESNER PRODUCTS, INC., NEW YORK, NY:
4,118,769, INT. CL. 25.
- WIGWAM MILLS, INC., SHEBOYGAN, WI:
1,190,773, REN. 2-22-12, INT. CL. 25.
- WILBUR-ELLIS COMPANY, SAN FRANCISCO, CA:
4,090,523, COR. INT. CL. 1.
- WILL SORRELL, LONDON, UNITED KINGDOM:
4,116,798, PUB. 1-10-2012, INT. CL. 28.
- WILLIAMS JR., WALTER F., RIO RANCHO, NM, DBA
ASTRAL COMPUTING:
4,117,702, PUB. 1-10-2012, INT. CL. 42.
- WILLIAMS MULLEN CLARK & DOBBINS, P.C., RICH-
MOND, VA:
2,660,776, REN. 2-17-12, INT. CL. 42.
- WILLIAMS, CHRISTOPHER, SPOTSYLVANIA, VA:
4,117,733, PUB. 1-10-2012, INT. CL. 41.
- WILLIAMS, STEVE, WESTON, FL:
4,119,328, INT. CL. 25.
- WILLIAMS, TED E., BOLIVIA, SC:
4,119,799, INT. CL. 28.
- WILLIAMSON, PAMELA, QUEEN CREEK, AZ:
4,118,284, PUB. 1-10-2012, INT. CL. 41.
- WILLOW DRIVE NURSERY, INC., EPHRATA, WA:
1,674,679, REN. 2-22-12, INT. CL. 42.
- WILLOW RIVER SALES LLC, HUDSON, WI:
4,116,643, PUB. 1-10-2012, INT. CL. 19.
- WILMINGTON ENDOCRINOLOGY, P.A., WILMINGTON,
NC:
4,118,344, PUB. 1-10-2012, MULTIPLE CLASS, INT. CLS.
35, 42 AND 44.
- WILSON, JULIA A., WASHINGTON, DC:
4,117,815, PUB. 1-10-2012, INT. CL. 35.
- WILSON, MARY LOUISE, BEDFORD, NH:
2,968,465, CANC. INT. CL. 16.
- WILSON, TINDALL & ASSOCIATES, INC., AUSTIN, TX:
4,117,698, PUB. 1-10-2012, INT. CL. 36.
- WINCHESTER DOWNTOWN PROGRAM, WINCHESTER,
TN:
4,116,657, PUB. 1-10-2012, INT. CL. 35.
- WINDHOVER TECHNOLOGY MANAGEMENT PTY LIM-
ITED, EAST MELBOURNE, VICTORIA, AUSTRALIA:
2,965,550, CANC. INT. CL. 37.
- WINDOW WORKS INTERNATIONAL, LLC, BROOKFIELD,
WI:
2,968,393, CANC. MULTIPLE CLASS, INT. CLS. 35, 37
AND 42.
- WINDSOR FASHIONS, INC., LOS ANGELES, CA:
2,554,675, REN. 2-21-12, INT. CL. 35.
- WINE FATHER, LLC, CHICAGO, IL:
4,118,803, INT. CL. 35.
- WINFIELD SOLUTIONS LLC, SHOREVIEW, MN:
2,968,068, CANC. INT. CL. 1.
- WINNER INTERNATIONAL ROYALTY LLC, SHARON, PA:
2,467,787, CANC. INT. CL. 6.
- WINSTEAD PC, DALLAS, TX:
4,116,583, PUB. 1-10-2012, INT. CL. 41.
4,116,584, PUB. 1-10-2012, INT. CL. 41.
- WIRELESS FACILITIES, INC., CHANTILLY, VA:
4,116,982, PUB. 1-10-2012, MULTIPLE CLASS, INT. CLS.
36, 37, 38, 42 AND 45.
- WIRELESS MATRIX USA, INC., A DELAWARE CORPORA-
TION, RESTON, VA:
2,968,153, CANC. INT. CL. 42.
- WISEGUY CLEANERS LLC, ISSAQUA, WA:
4,117,988, PUB. 1-10-2012, INT. CL. 37.
- WIZETRADE GROUP, LLP, THE, PLANO, TX:
2,968,363, CANC. INT. CL. 41.
2,968,364, CANC. INT. CL. 36.
- WKMN NETWORK TRAINING, LLC, DALY CITY, CA, DBA
REACH AND TEACH:
4,118,718, PUB. 1-10-2012, INT. CL. 16.
- WM. T. BURNETT IP, LLC, BALTIMORE, MD:
940,446, REN. 2-21-12, U.S. CL. 22 (INT. CL. 28).
- WM. WRIGLEY JR. COMPANY, CHICAGO, IL:
2,535,714, REN. 2-23-12, INT. CL. 30.
- WMS GAMING INC., CHICAGO, IL:
2,468,404, CANC. INT. CL. 9.
- WMS GAMING INC., WAUKEGAN, IL:
4,119,475, INT. CL. 9.
4,119,530, INT. CL. 9.
- WOLBRUECK, SUSAN J, MANITOU SPRINGS, CO:
4,118,288, PUB. 1-10-2012, INT. CL. 35.
- WOLF & WOLF SEEDS, INC., ORLANDO, FL:
4,119,374, INT. CL. 36.
- WOLF, ALLEN DONALD, SANTA MONICA, CA, DBA
MORNING STAR PICTURES:
2,584,690, REN. 2-21-12, INT. CL. 35.
2,611,762, REN. 2-21-12, INT. CL. 35.
- WOLF PAC TECHNOLOGIES, INC., ALIQUIPPA, PA:
4,119,315, INT. CL. 19.
- WOLO MANUFACTURING CORP., DEER PARK, NY:
4,117,420, PUB. 1-10-2012, INT. CL. 7.
- WOLPA, MARK E., BERKELEY, CA:
2,968,232, CANC. INT. CL. 30.
- WOLVERINE WORLD WIDE, INC, ROCKFORD, MI:
2,569,422, REN. 2-17-12, INT. CL. 25.
- WOOD, VIRGIL A., 2428 AMENO DR., TX:
2,525,416, REN. 2-22-12, MULTIPLE CLASS, INT. CLS. 16
AND 42.
- WOODBURY, DAVID A., LINCOLN, ME:
2,529,265, REN. 2-22-12, INT. CL. 41.
- WOODSPHERE PUBLISHING LLC, PHILADELPHIA, PA:
4,117,925, PUB. 1-10-2012, INT. CL. 41.
- WOODSTONE COMPANY, THE, WESTMINSTER, VT:
2,666,129, REN. 2-23-12, INT. CL. 19.
- WOOLPERT, INC., DAYTON, OH:
4,116,987, PUB. 1-10-2012, MULTIPLE CLASS, INT. CLS.
41 AND 42.
- WOONGJIN COWAY CO., LTD., CHOONGCHEONGNAM-
DO, REPUBLIC OF KOREA:
4,116,814, PUB. 1-10-2012, INT. CL. 11.
- WORKSPACE TECHNOLOGY, INC., PHILLIPSBURG, NJ:
4,117,545, PUB. 10-4-2011, INT. CL. 35.
- WORLD GOLF FOUNDATION, INC., ST. AUGUSTINE, FL:
4,118,051, PUB. 1-10-2012, MULTIPLE CLASS, INT. CLS.
24, 36 AND 41.
- WORLD ONE CUISINE TEXAS LLC, IRVING, TX:
4,118,085, PUB. 1-10-2012, INT. CL. 43.
4,118,201, PUB. 1-10-2012, INT. CL. 43.
- WORLD TREK TRAVEL, INC., PUEBLO, CO:
1,670,550, REN. 2-22-12, INT. CL. 39.
- WORLD WRESTLING ENTERTAINMENT, INC., STAM-
FORD, CT:
2,968,327, CANC. INT. CL. 16.
- WORLDQUANT, LLC, OLD GREENWICH, CT:
4,118,679, PUB. 1-10-2012, INT. CL. 36.
- WORLDWIDE FOOD SALES, INC., SAN PEDRO, CA,
WORLDWIDE FOOD SALES, INC.:
2,941,883, CANC. INT. CL. 36.
- WORLEY, JOHN W, DALLAS, TX:
4,117,755, PUB. 1-10-2012, INT. CL. 9.
- WOVENMEDIA, INC., GREENBRAE, CA:
4,117,669, PUB. 1-10-2012, INT. CL. 42.
- WP COMPANY LLC, WASHINGTON, DC:
4,119,507, INT. CL. 41.
- WP IP, LLC, NEW YORK, NY, WESTPOINT STEVENS INC. I,
LAS VEGAS, NV:
2,483,486, REN. 2-21-12, INT. CL. 24.
- WRITER ACCESS, INC., BOSTON, MA:
4,118,630, PUB. 1-10-2012, INT. CL. 41.
- WSHE, SUNRISE, FL:
4,117,726, PUB. 1-10-2012, INT. CL. 38.
- WSL MARKETING, INC., NEW YORK, NY, DBA WSL
STRATEGIC RETAIL:
4,117,949, PUB. 1-10-2012, INT. CL. 16.
- WUXI JUNZHENG TRADING CO., LTD., JIANGSU PRO-
VINCE, CHINA:
4,119,211, INT. CL. 25.
4,119,212, INT. CL. 28.
- WYBOROWA S.A., 61-023 POZNAN, POLAND:
4,117,479, PUB. 1-10-2012, INT. CL. 33.
- WYETH LLC, MADISON, NJ, WYETH, MADISON, NJ AND
WYETH, MADISON, NJ:
2,678,478, REN. 2-17-12, INT. CL. 5.

WYNRIGHT CORPORATION, ELK GROVE VILLAGE, IL:
4,118,907, MULTIPLE CLASS, INT. CLS. 7, 9, 37 AND 42.

X-RAY OPTICAL SYSTEMS, INC., EAST GREENBUSH, NY:
4,119,161, INT. CL. 9.

X-TECHNOLOGY SWISS GMBH, SWITZERLAND:
4,116,711, PUB. 1-10-2012. MULTIPLE CLASS, INT. CLS.
18, 25 AND 28.

XEROX CORPORATION, NORWALK, CT:
2,968,055, CANC. INT. CL. 9.
2,968,579, CANC. INT. CL. 9.

XM GROUP, INC., NORTH MIAMI BEACH, FL:
2,684,630, REN. 2-21-12. INT. CL. 35.

XO COMMUNICATIONS, LLC, HERNDON, VA:
2,967,801, CANC. INT. CL. 38.

XPEREDON GROUP SA, LUXEMBOURG:
4,116,724, PUB. 1-10-2012. MULTIPLE CLASS, INT. CLS.
9, 36 AND 38.

XRINGER INC., SAN JOSE, CA:
2,968,114, CANC. MULTIPLE CLASS, INT. CLS. 9 AND
38.

XU LEI, GUANGDONG, CHINA:
4,116,848, PUB. 1-10-2012. INT. CL. 24.

XYTEX CRYO INTERNATIONAL, LTD., AUGUSTA, GA:
2,524,241, REN. 2-17-12. INT. CL. 42.

X8 DRUMS & PERCUSSION, INC., JERSEY CITY, NJ AND
MARK A. STANCATO, JERSEY CITY, NJ AND KRISTIN
R. STANCATO, JERSEY CITY, NJ:
4,116,959, PUB. 1-10-2012. INT. CL. 15.

YAKIMA VALLEY MEMORIAL HOSPITAL CHARITABLE
FOUNDATION, INC., YAKIMA, WA:
2,528,870, REN. 2-22-12. INT. CL. 16.
2,557,650, REN. 2-22-12. INT. CL. 41.

YAKOS, MARVIN, REXFORD, MT:
2,968,276, CANC. INT. CL. 35.

YAMAMOTO, JO ANNE GAYLE, MANHATTAN BEACH,
CA:
2,968,044, CANC. INT. CL. 25.

YANMAR DIESEL ENGINE CO., LTD., OSAKA, JAPAN:
726,216, REN. 2-22-12. U.S. CL. 23 (INT. CL. 7).

YARDLEY, ILEXA, HOUSTON, TX:
2,968,147, CANC. INT. CL. 41.

YEUNG, JULIE C., GLENDORA, CA:
4,118,563, PUB. 1-10-2012. INT. CL. 14.
4,118,571, PUB. 1-10-2012. INT. CL. 14.

YF HOLDINGS, INC., ST. PETERSBURG, FL:
4,116,876, PUB. 6-15-2010. INT. CL. 41.

YI, YOUNG K., BETHESDA, MD:
2,468,439, CANC. INT. CL. 28.

YMC CO. LTD., KYOTO, JAPAN:
2,967,353, CANC. INT. CL. 9.

YOCREAM INTERNATIONAL, INC., PORTLAND, OR:
4,118,399, PUB. 1-10-2012. MULTIPLE CLASS, INT. CLS.
30, 32, 41 AND 43.

YODER, JJ, SAN DIEGO, CA, DBA PAY ATTENTION
CLOTHING:
4,118,391, PUB. 1-10-2012. INT. CL. 25.

YODER, JJ, SAN DIEGO, CA, DBA PAY ATTENTION
ENTERTAINMENT:
4,118,699, PUB. 1-10-2012. INT. CL. 41.

YOGA PURA, LLC, PHOENIX, AZ:
4,118,982, INT. CL. 44.
4,118,983, INT. CL. 16.

YONEX KABUSHIKI KAISHA, TOKYO, JAPAN:
2,967,899, CANC. INT. CL. 28.

YORK INTERNATIONAL CORPORATION,, MILWAUKEE,
WI:
2,538,356, REN. 2-21-12. INT. CL. 11.

YORK WALLCOVERINGS, INC., YORK, PA:
2,468,394, CANC. INT. CL. 16.

YORSAN GIDA MAMULLERI SANAYI VE TICARET ANO-
NIM SIRKETI, SUSURLUK BALIKESIR, TURKEY:
2,811,170, CANC. MULTIPLE CLASS, INT. CLS. 29 AND
32.

YOUNG BROADCASTING OF SIOUX FALLS, INC., SIOUX
FALLS, SD:
1,716,556, REN. 2-22-12. INT. CL. 38.
1,718,810, REN. 2-22-12. INT. CL. 38.

YOUNG DENTAL MANUFACTURING I, LLC, EARTH
CITY, MO:
2,526,533, REN. 2-23-12. INT. CL. 5.

YOUNG ESSENTIAL SKINCARE, INC, BEVERLY HILLS,
CA, DBA YES, INC.:
4,117,234, PUB. 1-10-2012. INT. CL. 5.

YOUNG SPORTS LTD, WAYNE, PA, DBA YOUNG SPORTS:
4,118,442, PUB. 1-10-2012. INT. CL. 41.

YOUNGSTOWN OHIO HOSPITAL COMPANY, LLC,
FRANKLIN, TN AND COMMUNITY HEALTH SYSTEMS,
INC., FRANKLIN, TN, HILLSIDE REHABILITATION
HOSPITAL, WARREN, OH:
1,662,085, REN. 2-22-12. INT. CL. 42.

YOUR PLANET EARTH LLC, PORTLAND, OR:
2,967,350, CANC. MULTIPLE CLASS, INT. CLS. 38 AND
42.

YP IP LIMITED, SOUTHAMPTON, UNITED KINGDOM:
4,117,776, PUB. 1-10-2012. INT. CL. 9.

YZ ENTERPRISES, INC., MAUMEE, OH:
2,968,017, CANC. INT. CL. 30.

ZANLYN LLC, IRVING, TX:
4,119,100, INT. CL. 30.

ZBABIES, LLC, FOND DU LAC, WI:
4,119,168, MULTIPLE CLASS, INT. CLS. 21 AND 25.

ZEHR, ROBERT J., NAPLES, FL:
4,118,430, PUB. 1-10-2012. INT. CL. 44.

ZELLER & GMELIN GMBH & CO. KG, EISLINGEN, FED
REP GERMANY:
2,560,871, REN. 2-23-12. MULTIPLE CLASS, INT. CLS. 1,
2 AND 3.

ZEN YUNG CO., LTD., TAIPEI, TAIWAN:
2,467,430, CANC. MULTIPLE CLASS, INT. CLS. 9 AND
28.

ZENIMAX MEDIA INC., ROCKVILLE, MD:
4,119,736, MULTIPLE CLASS, INT. CLS. 9 AND 41.

ZENOVA CORP., BROOKLYN, NY:
4,118,211, PUB. 1-10-2012. INT. CL. 42.

ZEST IP HOLDINGS LLC, ESCONDIDO, CA:
4,119,229, INT. CL. 10.

ZHANG, PAUL, GARDENA, CA, TA PDS ENTERPRISE
INC.:
4,119,562, INT. CL. 9.

ZHAO, WALTER GQ, MONTCLAIR, CA:
4,117,592, PUB. 1-10-2012. INT. CL. 9.

ZHEJIANG GOLEADER INDUSTRIES CO. LTD., PANAN
CITY, CHINA:
4,119,611, INT. CL. 6.

ZHEJIANG LEO CO., LTD., 317503 WENLING, ZHEJIANG,
CHINA:
4,116,781, PUB. 1-10-2012. INT. CL. 7.

ZHEJIANG MIASEN ELECTRIC APPARATUS CO., LTD.,
325800 ZHEJIANG PROVINCE, CHINA:
4,116,866, PUB. 1-10-2012. MULTIPLE CLASS, INT. CLS. 7
AND 9.

ZHEJIANG NAIBA PUMP CO., LTD., ZHEJIANG PRO-
VINCE, CHINA:
4,116,720, PUB. 1-10-2012. INT. CL. 12.

ZHEJIANG SUNLIGHT GROUP CO., LTD., ZHEJIANG,
CHINA:
2,666,050, REN. 2-21-12. INT. CL. 11.

ZIA SYSTEMS LLC, COLUMBUS, OH:
4,117,044, PUB. 1-10-2012. INT. CL. 9.

ZIBA DESIGN, INC., PORTLAND, OR:
1,671,419, REN. 2-22-12. INT. CL. 42.

ZICANA, LLC, WESTBURY, NY:
4,117,155, PUB. 1-10-2012. INT. CL. 19.

ZIFENG WANG, ALHAMBRA, CA:
4,119,608, INT. CL. 25.

ZIFF DAVIS PUBLISHING HOLDINGS INC., NEW YORK,
NY TO ZIFF DAVIS PUBLISHING HOLDINGS INC., NEW
YORK, NY:
2,467,296, CANC. INT. CL. 16.

ZIMMER, INC., WARSAW, IN:
2,967,451, CANC. INT. CL. 35.

ZINGENUITY, INC., FLOWER MOUND, TX:
4,118,215, PUB. 1-10-2012. MULTIPLE CLASS, INT. CLS.
36 AND 45.

4,118,217, PUB. 1-10-2012. MULTIPLE CLASS, INT. CLS.

- 36 AND 45.
 ZINGTIME, INC., MORAGA, CA:
 2,970,155, CANC. MULTIPLE CLASS, INT. CLS. 9, 35 AND 38.
- ZINSSER CO., INC., SOMERSET, NJ:
 2,967,391, CANC. INT. CL. 2.
- ZINUS INC., HAYWARD, CA:
 4,119,607, INT. CL. 20.
- ZODIAK RIGHTS LIMITED, LONDON W14 8RF, UNITED KINGDOM:
 4,116,697, PUB. 1-10-2012. MULTIPLE CLASS, INT. CLS. 9, 16, 25, 28, 38 AND 41.
- ZOSMA VENTURES, INC., DOVER, DE:
 4,117,518, PUB. 1-10-2012. INT. CL. 5.
- ZRODIA, LLC, RENO, NV:
 4,119,001, INT. CL. 9.
- ZUFFA, LLC, LAS VEGAS, NV:
 4,119,806, INT. CL. 9.
 4,119,807, INT. CL. 41.
- ZULLAS, L.C., SANDY, UT, DBA CAFE ZUPAS:
 4,117,612, PUB. 1-10-2012. INT. CL. 30.
 4,117,623, PUB. 1-10-2012. INT. CL. 30.
- ZUNAFISH VENTURES, INC., NEW YORK, NY:
 2,967,943, CANC. INT. CL. 35.
- ZURB, INC., CAMPBELL, CA:
 4,118,614, PUB. 1-10-2012. INT. CL. 42.
- ZURN INDUSTRIES, LLC, ERIE, PA:
 4,117,685, PUB. 1-10-2012. INT. CL. 11.
- ZUZII LLC, TULSA, OK:
 4,117,630, PUB. 1-10-2012. INT. CL. 25.
- ZYMS DISTRIBUTION GROUP INC., CLARKS SUMMIT, PA:
 4,117,171, PUB. 1-10-2012. INT. CL. 34.
- 1 OF A FIND NYC, INC., BROOKLYN, NY:
 4,118,319, PUB. 1-10-2012. INT. CL. 35.
- 1C EUROPE B.V., AMSTERDAM, NETHERLANDS:
 4,119,777, INT. CL. 16.
- 1ST LIGHT ENERGY, INC., MODESTO, CA:
 4,118,522, PUB. 1-10-2012. INT. CL. 37.
 4,118,524, PUB. 1-10-2012. INT. CL. 25.
- 1STDIBS.COM, INC., NEW YORK, NY:
 4,118,403, PUB. 1-10-2012. INT. CL. 41.
- 1400446 ALBERTA LTD., EDMONTON, ALBERTA, CANADA:
 4,117,018, PUB. 1-10-2012. INT. CL. 14.
- 1444555 ALBERTA LTD., GRANDE PRAIRIE, AB, CANADA, DBA 45 INNOVATIONS:
 4,116,929, PUB. 1-10-2012. INT. CL. 7.
- 19TH HOLE PRODUCTS, LLC, SPRING LAKE HEIGHTS, NJ:
 2,967,997, CANC. INT. CL. 3.
- 2 CHIKS, LLC, FORT MILL, SC:
 4,118,470, PUB. 1-10-2012. INT. CL. 26.
- 2 DADS, INC., MATTHEWS, NC:
 2,550,429, REN. 2-22-12. INT. CL. 35.
- 2NDSITE INC., TORONTO, ONTARIO, CANADA:
 4,116,964, PUB. 1-10-2012. INT. CL. 42.
 4,116,965, PUB. 1-10-2012. INT. CL. 42.
- 22LEARN, LLC, INDIO, CA:
 4,118,520, PUB. 1-10-2012. INT. CL. 9.
- 24-365 PET CARE SOLUTIONS, LLC, FARMINGTON, MI:
 4,119,769, MULTIPLE CLASS, INT. CLS. 44 AND 45.
- 24/7 HAIR, GREAT NECK, NY:
 4,118,770, INT. CL. 26.
- 256 CORPORATION, HUNTSVILLE, AL:
 4,117,875, PUB. 1-10-2012. INT. CL. 42.
- 3 DAY BLINDS CORPORATION, ANAHEIM, CA:
 2,968,426, CANC. INT. CL. 9.
- 3 LEGGED THING LIMITED, STAGSDEN, UNITED KINGDOM:
 4,119,640, MULTIPLE CLASS, INT. CLS. 9 AND 25.
- 3L-LUDVIGSEN A/S, DENMARK:
 4,116,715, PUB. 1-10-2012. INT. CL. 16.
- 3M COMPANY, ST. PAUL, MN:
 4,119,751, INT. CL. 1.
- 3PR CORPORATION, RENO, NV:
 2,968,570, CANC. INT. CL. 35.
- 3TAILER, CHARLOTTE, NC:
 4,118,148, PUB. 1-10-2012. INT. CL. 35.
- 3TRACE, IRVINE, CA, DBA TRACE3:
 4,119,334, INT. CL. 36.
- 350 MARKET STREET, LLC, ST. PAUL, MN:
 1,670,667, REN. 2-21-12. INT. CL. 42.
- 3681441 CANADA INC., MONTREAL, QUEBEC, CANADA:
 1,185,897, REN. 2-22-12. INT. CL. 25.
- 4K COMPUTER LLC, HOUSTON, TX:
 4,119,847, MULTIPLE CLASS, INT. CLS. 9, 38 AND 42.
- 4LIFE TRADEMARKS, LLC, SANDY, UT:
 2,680,526, REN. 2-17-12. INT. CL. 5.
- 4028546 CANADA INC., OAKVILLE, ONTARIO, CANADA:
 4,119,112, MULTIPLE CLASS, INT. CLS. 9, 41 AND 45.
- 5/8EME COSMETO, FRANCE:
 4,116,676, PUB. 1-10-2012. INT. CL. 3.
- 512 LOCAL, LLC, AUSTIN, TX:
 4,117,913, PUB. 12-6-2011. INT. CL. 25.
- 52 BLOCKS INC., NEW YORK, NY:
 4,119,240, MULTIPLE CLASS, INT. CLS. 25 AND 28.
- 7TH REVOLUTION CLOTHING LLC, LOS GATOS, CA:
 4,117,695, PUB. 1-10-2012. MULTIPLE CLASS, INT. CLS. 25 AND 35.
- 72 BLUE, INC., MISSOULA, MT:
 4,118,887, INT. CL. 25.
- 7847335 CANADA INC., TORONTO, ONTARIO, CANADA:
 4,117,614, PUB. 1-10-2012. INT. CL. 45.
- 7933657 CANADA, INC., MONTREAL QUEBEC, CANADA:
 2,468,473, CANC. INT. CL. 25.
- 9TH STREET PUBLISHING, LLC, GREEN BAY, WI:
 4,117,193, PUB. 1-10-2012. INT. CL. 41.

* * * * *